

FINAL SAFETY ANALYSIS REPORT

CHAPTER 10

STEAM AND POWER CONVERSION SYSTEM

10.0 STEAM AND POWER CONVERSION SYSTEM

This chapter of the U.S. EPR Final Safety Analysis Report (FSAR) is incorporated by reference with supplements as identified in the following sections.

I

10.1 SUMMARY DESCRIPTION

This section of the U.S. EPR FSAR is incorporated by reference.

10.2 TURBINE-GENERATOR

This section of the U.S. EPR FSAR is incorporated by reference with the following supplements.

10.2.1 DESIGN BASES

No departures or supplements.

10.2.2 GENERAL DESCRIPTION

No departures or supplements.

10.2.3 TURBINE ROTOR INTEGRITY

No departures or supplements.

10.2.3.1 Materials Selection

The U.S. EPR FSAR includes the following COL Holder Item in Section 10.2.3.1:

A COL applicant that references the U.S. EPR design certification will provide applicable material properties of the turbine rotor after the site-specific turbine has been procured.

This COL Holder Item is addressed as follows:

Following procurement of the {{BBNPP}} turbine generator, {{PPL Bell Bend, LLC}} shall submit to the NRC the applicable material properties of the turbine rotor.

10.2.3.2 Fracture Toughness

The U.S. EPR FSAR includes the following COL Holder Item in Section 10.2.3.2:

A COL applicant that references the U.S. EPR design certification will provide applicable turbine disk rotor specimen test data, load-displacement data from the compact tension specimens and fracture toughness properties after the site-specific turbine has been procured.

This COL Holder Item is addressed as follows:

Following procurement of the {BBNPP} turbine generator, {PPL Bell Bend, LLC} shall submit to the NRC the applicable turbine disk rotor specimen test data, load-displacement data from the compact tension specimens and the fracture toughness properties to demonstrate that the associated information and data presented in the U.S. EPR FSAR is bounding.

10.2.3.3 High Temperature Properties

No departures or supplements.

10.2.3.4 Turbine Rotor Design

No departures or supplements.

10.2.3.5 Turbine Rotor Preservice Inspections and Testing

No departures or supplements.

10.2.3.6 Turbine Rotor Inservice Inspection Program Plan

The U.S. EPR FSAR includes the following COL Item in Section 10.2.3.6:

A COL applicant that references the U.S. EPR design certification will provide the site-specific turbine rotor inservice inspection interval consistent with the manufacturer's turbine missile analysis.

This COL Item is addressed as follows:

The turbine manufacturer recommends major rotor inspection intervals of 10 years, during major overhauls. The inspections are performed during refueling outages on an interval consistent with the inservice inspection schedules in ASME Section XI so that a total inspection has been completed at least once within a 10 year time period.

10.2.4 SAFETY EVALUATION

No departures or supplements.

10.2.5 REFERENCES

No departures or supplements.

10.3 MAIN STEAM SUPPLY SYSTEM

This section of the U.S. EPR FSAR is incorporated by reference with the following supplements.

10.3.1 DESIGN BASES

No departures or supplements.

10.3.2 SYSTEM DESCRIPTION

No departures or supplements.

10.3.3 SAFETY EVALUATION

No departures or supplements.

10.3.4 INSPECTION AND TESTING REQUIREMENTS

No departures or supplements.

10.3.5 SECONDARY SIDE WATER CHEMISTRY PROGRAM

The U.S. EPR FSAR includes the following COL Item in Section 10.3.5:

A COL applicant that references the U.S. EPR design certification will identify the authority responsible for implementation and management of the secondary side water chemistry program.

This COL Item is addressed as follows:

{PPL Bell Bend, LLC} shall implement the secondary side water chemistry program described in Section 10.3.5 of the U.S. EPR FSAR. The {Radiation Protection and Chemistry Manager} is the authority responsible for implementation and management of the secondary side water chemistry program.

10.3.6 STEAM AND FEEDWATER SYSTEM MATERIALS**10.3.6.1 Material Selection and Fabrication**

No departures or supplements.

10.3.6.2 Fracture Toughness

No departures or supplements.

10.3.6.3 Flow-Accelerated Corrosion

The U.S. EPR FSAR includes the following COL Holder Item in Section 10.3.6.3:

The COL applicant that references the U.S. EPR design certification will develop and implement a FAC condition monitoring program that is consistent with Generic Letter 89-08 and NSAC-202L-R3 for the carbon steel portions of the steam and power conversion systems that contain water or wet steam prior to initial fuel loading.

This COL Holder Item is addressed as follows:

{PPL Bell Bend, LLC} shall develop and implement, prior to fuel loading, a flow accelerated corrosion (FAC) program that provides a structured, logical approach to identifying locations in the steam and power conversion system that could be susceptible to degradation of pressure boundary thickness due to erosion/corrosion (EC) and flow conditions. The FAC Program will be consistent with requirements and recommendations of Generic Letter 89-08 "Erosion/Corrosion-Induced Pipe Wall Thinning" (NRC, 1989) and NSAC-202L-R3 "Recommendations for an Effective Flow Accelerated Corrosion Program" (EPRI, 2006).

Multiple criteria are identified, which alone or in combination can create conditions where erosion/corrosion will result from process flow conditions. These criteria include process fluid characteristics (water, steam, two-phase, chemical characteristics), process flow rate, flow path configuration (straight pipe, elbow, valve body, elevation change, etc.), temperature, pressure, duty cycles or cycling of conditions (variations in temperature, pressure, steam quality or wetness, etc.), pressure boundary mechanical stresses (e.g., temperature-induced pipe growth), and materials of construction.

These criteria are evaluated during the design and construction phases using industry operating experience to identify locations that are susceptible to FAC. Adjustments are made to pipe routing and component locations to minimize flow velocities and turbulence. In addition, water chemistry requirements are established and materials of construction are selected to further limit contributing factors.

The water chemistry program for the steam and power conversion system is focused on prevention of corrosion, and is thus integral to the control of FAC. Emphasis is placed on control of dissolved impurities that contribute to corrosion and removal of corrosion products. Water chemistry is discussed in Section 10.3.5.

Prior to operation, preservice examinations (to include thickness measurements) are performed in accordance with the FAC Program procedures. The preservice examinations are performed following system construction completion (usually denoted by performance of the system hydrostatic test), but prior to plant operation. Preservice examinations are conducted using grid locations and measurement methods anticipated for the inservice examination according to industry guidelines and previous industry experience. Grid locations are determined based upon industry operating experience and a FAC modeling software program, in accordance with Generic Letter 89-08 (NRC, 1989) and NSAC-202L-R3 (EPRI 2006). Examinations are conducted during inservice examinations to determine the extent of any flow accelerated corrosion. The examination schedule and processes are in accordance with the inservice FAC Program requirements. Examination results are then analyzed to provide additional points and the need to replace components, based upon the wear rates and remaining allowable wall thicknesses. This examination is based on the inservice FAC Program, in accordance with Generic Letter 89-08 (NRC, 1989) and NSAC-202L-R3 (EPRI 2006).

Examination results for preservice and inservice examinations are recorded and trended throughout the plant operating life in the FAC database or other appropriate recording means. As data are accumulated for each location, the actual existence of FAC, or lack thereof, can be established as well as the rate of pressure boundary reduction in thickness. With this information, the frequency of examinations can be adjusted as appropriate to assure accurate understanding of the physical condition and maintenance of the required minimum wall thickness, design margins of safety, and piping integrity. In addition, necessary repairs or replacements, including material changes, can be accomplished in a planned and efficient manner.

The FAC program will include preservice and inservice examinations of main steam supply system (MSSS) and feedwater system carbon steel components containing $\geq 0.10\%$ chromium content that are susceptible to flow accelerated corrosion. Consistent with the guidance of NSAC-202L-R3, components with $\geq 0.10\%$ chromium content may be removed from the program if no degradation has occurred.

10.3.7 REFERENCES

{**EPRI, 2006.** "Recommendations for an Effective Flow-Accelerated Corrosion Program," NSAC-202L-R3, Electric Power Research Institute, 2006.

NRC, 1989. "Erosion/Corrosion-Induced Pipe Wall Thinning" Generic Letter 89-08, Nuclear Regulatory Commission, 1989.}

10.4 OTHER FEATURES OF STEAM AND POWER CONVERSION SYSTEM

This section of the U.S. EPR FSAR is incorporated by reference with the following supplements.

10.4.1 MAIN CONDENSERS

No departures or supplements.

10.4.1.1 Design Basis

No departures or supplements.

10.4.1.2 System Description

The U.S. EPR FSAR includes the following COL Item in Section 10.4.1.2:

The COL applicant that references the U.S. EPR design certification will describe the site-specific main condenser materials.

This COL Item is addressed as follows:

{The site-specific main condenser for BBNPP will be comprised of stainless steel tubes and stainless steel-clad tube sheet.}

The U.S. EPR FSAR includes the following COL Item in Section 10.4.1.2:

The COL applicant that references the U.S. EPR design certification will describe the site-specific design pressure and test pressure for the main condenser.

This COL Item is addressed as follows:

{The site-specific design pressure and test pressure for the main condenser at BBNPP are 100 psig (690 kPa-gauge) and 150 psig (1034 kPa-gauge), respectively.}

10.4.1.3 Safety Evaluation

No departures or supplements.

10.4.1.4 Inspection and Testing Requirements

No departures or supplements.

10.4.1.5 Instrumentation Requirements

No departures or supplements.

10.4.2 MAIN CONDENSER EVACUATION SYSTEM

No departures or supplements.

10.4.3 TURBINE GLAND SEALING SYSTEM

No departures or supplements.

10.4.4 TURBINE BYPASS SYSTEM

No departures or supplements.

10.4.5 CIRCULATING WATER SYSTEM

No departures or supplements.

10.4.5.1 Design Basis

No departures or supplements.

10.4.5.2 System Description

10.4.5.2.1 General Description

The U.S. EPR FSAR includes the following COL Item in Section 10.4.5.2.1:

A COL applicant that references the U.S. EPR design certification will provide the description of the site-specific portions of the CWS.

This COL Item is addressed as follows:

The U.S. EPR uses a Circulating Water System (CWS) to dissipate heat. {The CWS is a closed-loop system. The CWS uses two non-plume abated natural draft cooling towers for heat dissipation.}

{The CWS dissipates approximately $1.0E+10$ BTU/hr ($2.52E+09$ Kcal/hr) of waste heat rejected from the main condenser and the Closed Cooling Water System (CLCWS) during normal plant operation at full station load. The Piping and Instrumentation Diagram (P&ID) for the CWS is provided as Figure 10.4-1 and U.S. EPR FSAR Figure 10.4.5-1, Sheet 2 of 2. Figure 10.4-1 shows the system at the cooling tower and U.S. EPR FSAR Figure 10.4.5-1, Sheet 2 of 2 shows the system inside the Turbine Building. The CWS has four 25% capacity constant speed, vertical shaft type circulating water pumps housed in the CWS Pumphouse adjacent to the cooling towers. These pumps circulate water through the system.

In the Turbine Building, the majority of the CWS flow is directed through the main condenser, where the water removes (primarily) latent heat of vaporization from the turbine exhaust steam. The water travels through the three condenser shells (tube side), which are arranged in series, and then returns to the CWS cooling towers via the CWS return piping.

Additionally, two 100% capacity auxiliary cooling water system pumps receive cooling water from the CWS and deliver the water to the CLCWS heat exchangers. Heat from the CLCWS is transferred to the auxiliary cooling water system and heated auxiliary cooling water is returned to the CWS downstream of the main condenser.

The heated CWS water is sent to the spray headers of the cooling towers. After passing through the cooling towers, the cooled water is recirculated back to the CWS Pumphouse to complete the closed cycle cooling water loop. The CWS has a nominal flow rate of approximately 720,000 gpm (2,725,500 lpm).

CWS cooling tower design specifications are provided in Table 10.4-1. The CWS Pumphouse is shown in Figure 10.4-2 and Figure 10.4-3. The cooling towers are shown in Figure 10.4-4.

Evaporation in the cooling towers increases the level of solids in the circulating water. To control solids, a portion of the recirculated water is removed or blown down and replaced with clean water. In addition to the blowdown and evaporative losses, a small percentage of water in the form of droplets (drift) is lost from the cooling towers. Peak anticipated evaporative losses are 15,872 gpm (60,082 lpm). Maximum drift losses are about 8 gpm (30 lpm) based

upon 0.001% of the CWS nominal flow rate. Makeup water is required to replace the losses from evaporation, blowdown, and drift.

Makeup water for the CWS is taken from the Susquehanna River by pumps at a rate of 23,808 gpm (90,123 lpm). This rate is based on maintaining the CWS while operating at three cycles of concentration, as discussed in Section 9.2.5.1. Three 50% capacity vertical shaft type CWS makeup pumps housed in the CWS Makeup Water Intake Structure transfer water from the Susquehanna River to the cooling tower basins. Makeup water from the Susquehanna River is received into the intake structure via the intake structure forebay at the river bank. The intake structure houses the three CWS makeup pumps, three Raw Water Supply System (RWSS) pumps, bar grating, and dual-flow traveling screens. There are three bays, each bay containing a CWS makeup pump, a RWSS pump, a dual-flow traveling screen, and a screen wash pump. The purpose of the traveling screens is to prevent debris from passing into the CWS makeup pumps, circulating water pumps, condenser, and CLCWS heat exchangers. The intake structure also utilizes a trash rake. The CWS makeup system is shown in Figure 10.4-6. The intake structure is shown in Figure 10.4-5 and Figure 10.4-7.

Blowdown from the cooling towers discharges to a common retention basin to provide time for settling of suspended solids and to permit further chemical treatment of the wastewater, if required. Discharge from the retention basin is routed along the CWS makeup and RWSS intake pipe routing to the discharge diffuser, where it disperses into the Susquehanna River. Discharge temperature is monitored prior to discharge into the river. The retention basin discharge flowpath is shown in Figure 10.4-8. The discharge diffuser is shown in Figure 10.4-9.

The CWS chemical treatment system provides a means for adding chemicals to the circulating water system to maintain circulating water system chemistry within established limits to minimize fouling, inhibit scaling on the heat exchange surfaces, to control biological growth, and to inhibit corrosion of piping materials.}

In addition, this COL Item is addressed by replacing the conceptual design information identified in double brackets in U.S. EPR FSAR Section 10.4.5 with plant specific information as discussed in the following sections.

10.4.5.2.2 Component Description

Cooling Towers

The U.S. EPR FSAR includes the following conceptual design information in Section 10.4.5.2.2 for the Cooling Towers:

[[The CWS has mechanical draft cooling towers, each with a basin and circulating water sump. Each sump houses a circulating water pump. The sumps are designed to provide sufficient submergence of the pump suction. Trash racks or suction screens are provided to prevent the ingestion of debris.]]

The above conceptual design information is replaced with site-specific information as follows:

{The CWS cooling towers are non-plume abated natural draft cooling towers. Each tower structure is approximately 350 ft (107 m) in diameter at the base and 475 ft (145 m) tall. The towers function as an all-wet system.

Heat dissipation from the circulating water system to the ambient air (primarily latent heat transfer with some sensible heat transfer) occurs by direct contact between the rising air and the circulating water falling from the tower spray nozzles.

The tower fill redirects the water falling through the towers into thin vertically oriented films, which maximizes surface area of water in contact with surrounding air. The towers' hyperbolic shape draws the air from the towers vicinity into the towers, upward through the fill and falling water, and through the exit at the top of the towers.

The common cooling tower basin is located below the tower structures and serves as the collection point for the CWS cold water after it has fallen through the towers. The basin drains through a flume to the CWS Pumphouse forebay, which is shaped and sloped to serve as the suction point for the circulating water pumps. The CWS Pumphouse bays are sized to meet pump suction head requirements. The flume to the circulating water pump structure forebay is designed to prevent formation of harmful vortices at the pump suctions. The basins will be sized to provide sufficient volume to allow draindown of the CWS without overflow with the basin initially at maximum operating water level. Basin level is controlled by a level control system.

Table 10.4-1 provides CWS cooling tower design specification information.}

Circulating Water Pumps

The U.S. EPR FSAR includes the following conceptual design information in Section 10.4.5.2.2 for the Circulating Water Pumps:

[[The circulating water pumps are constant speed, vertical shaft type. The pumps are designed to operate under normal plant operating load conditions. Each pump has its suction located in its own pump bay. The pumps are designed to permit reverse flow.]]

The above conceptual design information is replaced with site-specific information as follows:

{Four 25% capacity constant speed, vertical shaft type pumps, each with a capacity of 181,982 gpm (688,877 lpm), are used to provide the circulating water flow and the CWS blowdown flow. The pumps are designed to permit reverse flow. Each pump has its suction head located in its own pump bay. The pumps draw water from the common cooling tower basin and deliver it to two concrete supply headers each approximately 11 ft (3.35 m) in diameter. Each pump is driven by a motor rated at approximately 9,000 HP (6.7 MW). The pumps are sized to provide sufficient head to overcome energy losses due to friction, piping elevation changes, and static head requirements for the cooling tower.}

Cooling Tower Makeup System

The U.S. EPR FSAR includes the following conceptual design information in Section 10.4.5.2.2 for the Cooling Tower Makeup System:

[[The cooling tower makeup system is site-specific and will be designed to provide adequate makeup flow to the cooling tower basins.]]

The above conceptual design information is replaced with site-specific information as follows:

{The CWS Makeup System functions to replace CWS water losses due to evaporation, blowdown, and drift associated with the cooling towers as well as leakage and seepage losses from the basin and system piping and components. Makeup rate is controlled by the tower

basin level control system and the makeup system control valve. Three 50% capacity vertical shaft type CWS makeup pumps housed in the CWS Makeup Water Intake Structure transfer water from the Susquehanna River to the cooling tower basins. The intake structure houses the three CWS makeup pumps, three Raw Water Supply System (RWSS) pumps, bar grating, and dual-flow traveling screens. The purpose of the traveling screens is to prevent debris from passing into the CWS makeup pumps, circulating water pumps, condenser, and CLCWS heat exchangers. The screen wash system consists of three screen wash pumps that provide a pressurized spray to remove debris from the traveling screens. The CWS Makeup Water Intake Structure also utilizes a trash rake. The CWS Makeup System is shown in Figure 10.4-6. The CWS Makeup Water Intake Structure is shown in Figure 10.4-5 and Figure 10.4-7. }

Chemical Treatment System

The U.S. EPR FSAR includes the following conceptual design information in Section 10.4.5.2.2 for the Chemical Treatment System:

[[Water treatment for the CWS is based on site makeup water chemistry, blowdown requirements, environmental regulations and system materials.]]

The above conceptual design information is replaced with site-specific information as follows:

Chemical treatment system pumps, valves, tanks, instrumentation, and controls provide the means of monitoring water chemistry and adding required chemicals into the CWS in order to minimize corrosion, prevent scale formation, and limit biological fouling.

Chemicals used in the system are compatible with materials used for piping and component wetted surfaces.

The U.S. EPR FSAR includes the following COL Item in Section 10.4.5.2.2 for the Chemical Treatment System:

A COL applicant that references the U.S. EPR design certification will provide the specific chemicals used to support the chemical treatment system as determined by the site-specific water conditions.

This COL Item is addressed as follows:

The specific chemicals and addition rates used in the system are determined and adjusted as required by evaluation of periodic water chemistry analyses.

{An oxidizing biocide is selected to control microbiological growth in service water piping to control fouling, microbiological deposits, and microbiological-related corrosion in the piping. Sodium hypochlorite solution is injected intermittently at the CWS Makeup Water Intake Structure near the RWSS pumps.

The following chemicals will be added at the CWS cooling tower common basin:

- ◆ Biocide - sodium hypochlorite - periodic treatment to the CWS pump suction in the forebay for no more than two hours per day as required by the National Pollution Discharge Elimination System (NPDES) permit requirements.
- ◆ pH adjuster - sulfuric acid - continuous feed of sulfuric acid to the CWS pump suction in the forebay.

- ◆ Deposit control agents - phosphonate and acrylate copolymer - continuous feed of proprietary chemicals to the CWS pump suction in the forebay.
- ◆ Corrosion inhibitor - the phosphonate used as a deposit control agent will also provide inhibition of mild steel corrosion in alkaline systems, therefore a separate corrosion inhibitor is not required.

These chemicals will be stored on site.

The NPDES permit will have a limit on residual chlorine, which will result in the need to add a chemical such as sodium bisulfite at the Waste Water Retention Basin outlet or other appropriate point to ensure that the plant discharge meets the limit.

Sample ports are installed at the CWS supply headers, CWS makeup header, and Waste Water Retention Basin discharge piping. Grab samples are analyzed at the chemistry lab.

Monitoring will be consistent with chemical vendor recommendations required for chemical dosage and performance.

The NPDES permit may require additional environmental compliance monitoring at point sources, such as pump discharges to oil/water separator.

Residual chlorine is measured to monitor the effectiveness of biocide treatment. Conductivity and pH are also monitored.}

Cooling Tower Blowdown System

The U.S. EPR FSAR includes the following conceptual design information in Section 10.4.5.2.2 for the Cooling Tower Blowdown System:

[[The cooling tower blowdown system is site-specific, and along with the makeup system will be designed to maintain the concentration of dissolved solids in the CWS within acceptable limits.]]

The above conceptual design information is replaced with site-specific information as follows:

{The non-safety-related CWS blowdown system consists of piping, valves, and associated instrumentation and controls that convey water from the CWS pump discharge to the Waste Water Retention Basin prior to its discharge to the Susquehanna River. Blowdown from the discharge of the CWS pumps is controlled by a control valve.

The Waste Water Retention Basin and discharge diffuser are important components of the CWS. Discussion of these components is provided below as a supplement to the U.S. EPR FSAR.

Waste Water Retention Basin

The Waste Water Retention Basin serves as a collection point for the following discharge sources prior to their discharge in the Susquehanna River:

- ◆ CWS cooling tower blowdown.
- ◆ Essential Service Water System (ESWS) cooling tower blowdown.

◆ Other plant discharges.

The Waste Water Retention Basin serves as a means of settling out suspended solids from plant discharges.

One discharge pipe conveys the discharge flow from the Waste Water Retention Basin to the Susquehanna River. Treated water from the liquid radwaste system (see Section 11.2) acceptable for discharge joins the main discharge flow between the Waste Water Retention Basin and the discharge diffuser. The driving force for flow is gravity.

Waste Water Retention Basin Discharge

The Waste Water Retention Basin discharge consists of a discharge header, the discharge diffuser, valves, and associated instrumentation and controls for the control and monitoring of discharge flow into the Susquehanna River.

The discharge diffuser is designed to meet all applicable navigation and maintenance criteria to provide an acceptable mixing zone for the thermal plume. The discharge piping is routed to the discharge diffuser at approximately 476 ft (145 m) elevation in the river. Figure 10.4-8 shows the flowpath of the discharge piping.

Flow in the discharge header is directed to the discharge diffuser which has port holes that increase the flow velocity and serve as the exit point for discharges into the Susquehanna River. The centerline elevation of the discharge above the river bed elevation varies as the river bed elevation varies. Exit velocity for the discharge flow has been evaluated to be adequate for thermal mixing purposes.}

Piping and Valves

The U.S. EPR FSAR includes the following conceptual design information in Section 10.4.5.2.2 for the Piping and Valves:

[[A butterfly valve is installed downstream of each circulating water pump.]] Isolation valves are installed at the inlets of the low pressure condenser water box and outlets of the high pressure condenser water box. [[Each cooling tower riser also has a butterfly valve that serves to isolate the cooling tower cell during maintenance activities. The butterfly valves contained in the CWS are designed to operate under normal plant operating load conditions. Valve opening and closing times are chosen to reduce water hammer effects.]]

The above conceptual design information is replaced with site-specific information for the plant as follows:

{The U.S. EPR FSAR description provided above is applicable to the CWS and is incorporated by reference.}

The U.S. EPR FSAR includes the following COL Item in Section 10.4.5.2.2 for Piping and Valves:

A COL applicant that references the U.S. EPR design certification will provide the site-specific CWS piping design pressure.

This COL Item is addressed as follows:

{The CWS piping and CWS blowdown piping design pressure is 100 psig (690 kPa-gauge). The CWS makeup piping design pressure is 275 psig (1,900 kPa-gauge). The Waste Water Retention Basin discharge piping design pressure is 50 psig (345 kPa-gauge).}

Vacuum Breaker

No departures or supplements.

Condenser Tube Cleaning System

No departures or supplements.

Vacuum Priming System

The U.S. EPR FSAR includes the following COL Item in Section 10.4.5.2.2 for the Vacuum Priming System:

If a vacuum priming system is required, a COL applicant that references the U.S. EPR design certification will provide the site-specific information.

This COL Item is addressed as follows:

{A vacuum priming system is not required at BBNPP.}

Vents and Drains

No departures or supplements.

10.4.5.2.3 System Operation

{No departures or supplements.}

10.4.5.3 Safety Evaluation

The U.S. EPR FSAR includes the following COL Item and conceptual design information in Section 10.4.5.3:

A COL applicant that references the U.S. EPR design certification will provide information to address the potential for flooding of safety-related equipment due to failure of the site-specific CWS.

[[Means are provided to prevent or detect and control flooding of safety-related areas so that the intended safety function of a system or component will not be diminished due to leakage from the CWS.]]

[[Malfunction or failure of a component or piping in the CWS, including an expansion joint, will not produce unacceptable adverse effects on the functional performance capabilities of safety-related systems or components.]]

The above COL Item is addressed and the conceptual design information is replaced with site-specific information as follows:

{Internal flooding of the Turbine Building due to an unisolable break or crack in a circulating water system pipe or failure of a CWS component, including expansion joints, does not result in damage to safety-related SSCs. Below the main steam piping penetrations, no direct pathway through which flooding could spread exists between the Turbine Building and adjacent

structures that house safety-related SSCs. No safety-related SSCs reside in the Turbine Building. Flooding exiting the Turbine Building at grade is directed away from structures that house safety-related SSCs by site grading, so external flooding resulting from a failure in the CWS does not adversely affect safety-related SSCs.

A failure in the CWS Makeup Water supply line does not result in damage to safety-related SSCs. This is due to the design of the site grading and drainage. Buildings that house safety-related SSCs are constructed with ground floor slabs elevated above grade and intervening topography and site drainage configuration would direct released water away from areas where it might otherwise cause damage. In addition, in the event of a CWS Makeup Water supply line failure, the CWS Makeup pumps could be shut-off, the MOVs could be closed, and the isolation valves at the plant site could be closed.}

10.4.5.4 Inspection and Testing Requirements

No departures or supplements.

10.4.5.5 Instrumentation Requirements

The U.S. EPR FSAR includes the following conceptual design information in Section 10.4.5.5:

[[Pressure is measured at the discharge of each circulating water pump. Temperature is measured at the condenser inlet and outlet for each tube bundle.]] The circulating water is also monitored for pH and conductivity. [[Permanent flowmeters measure individual circulating pump flow and total flow to the turbine condenser. Access ports allow temporary flowmeters to be installed in the main circulating water piping. Cooling tower basin level is monitored and used to control makeup flow. Blowdown is manually adjusted as required to maintain desired water chemistry.]]

The above conceptual design information is replaced with site-specific information as follows:

{Instrumentation and controls for the CWS include provisions for remote and local control and monitoring of parameters such as pressure, temperature, and flow. Motor winding temperature sensors mounted at various locations in the motors along with bus power and breaker position provide remote control, indication, and alarm of the circulating water pumps.

The opening and closing of motor operated valves located at each pump's discharge, on the cooling tower bypass, at the inlet and outlet of the condensers, and at various other points within the process system are remotely controlled and monitored, but can be manually operated via valve mounted hand wheels.

System temperature, pressure, and flow are monitored in each of the CWS pump discharge lines as well as at various other points. A means is provided to utilize temporary flow metering equipment on the main CWS piping. The CWS cooling tower basin level is controlled by varying the makeup water flow as monitored by the basin level control system. Blowdown flow rate is monitored and controlled by adjusting the position of the blowdown control valve. At the CWS Makeup Water Intake Structure, differential pressure across the traveling screens provides indication of fouling and initiates the screen cleaning system.}

10.4.5.6 References

No departures or supplements.

10.4.6 CONDENSATE POLISHING SYSTEM

No departures or supplements.

10.4.7 CONDENSATE AND FEEDWATER SYSTEM

No departures or supplements.

10.4.8 STEAM GENERATOR BLOWDOWN SYSTEM (PWR)

No departures or supplements.

10.4.9 EMERGENCY FEEDWATER SYSTEM

No departures or supplements.

Table 10.4-1—{Circulating Water System Cooling Tower Design Specifications}

Design Conditions	Natural Draft Cooling Tower
Number of Towers	2
Heat Load	1.0E+10 BTU/hr (2.52E+09 Kcal/hr)
Circulating Water	720,000 gpm (2,725,496 lpm)
Cycles of Concentration—Normal	3
Evaporative losses	15,872 gpm (60,082 lpm)
Blowdown rate	7,928 gpm (30,011 lpm)
Drift Rate	<0.001%
Drift losses	8 gpm (30 lpm)
Approximate Dimensions—Height	475 ft (145 m)
Approximate Dimensions—Diameter	350 ft (107 m) (at the base)
Design Dry Bulb Temperature	81°F (27.2°C) (summer)
Design Wet Bulb Temperature	73°F (22.8°C) (summer)
Design Range	27.6°F (15.3°C)
Design Approach	17°F (9.4°C)
Design Outlet Temperature	90°F (32.2°C)
Air Flow Rate (at ambient design point)	54,850,000 cfm (1,553,000 m ³ per min)

Figure 10.4-1—{Circulating Water System P&ID (at Cooling Tower)}

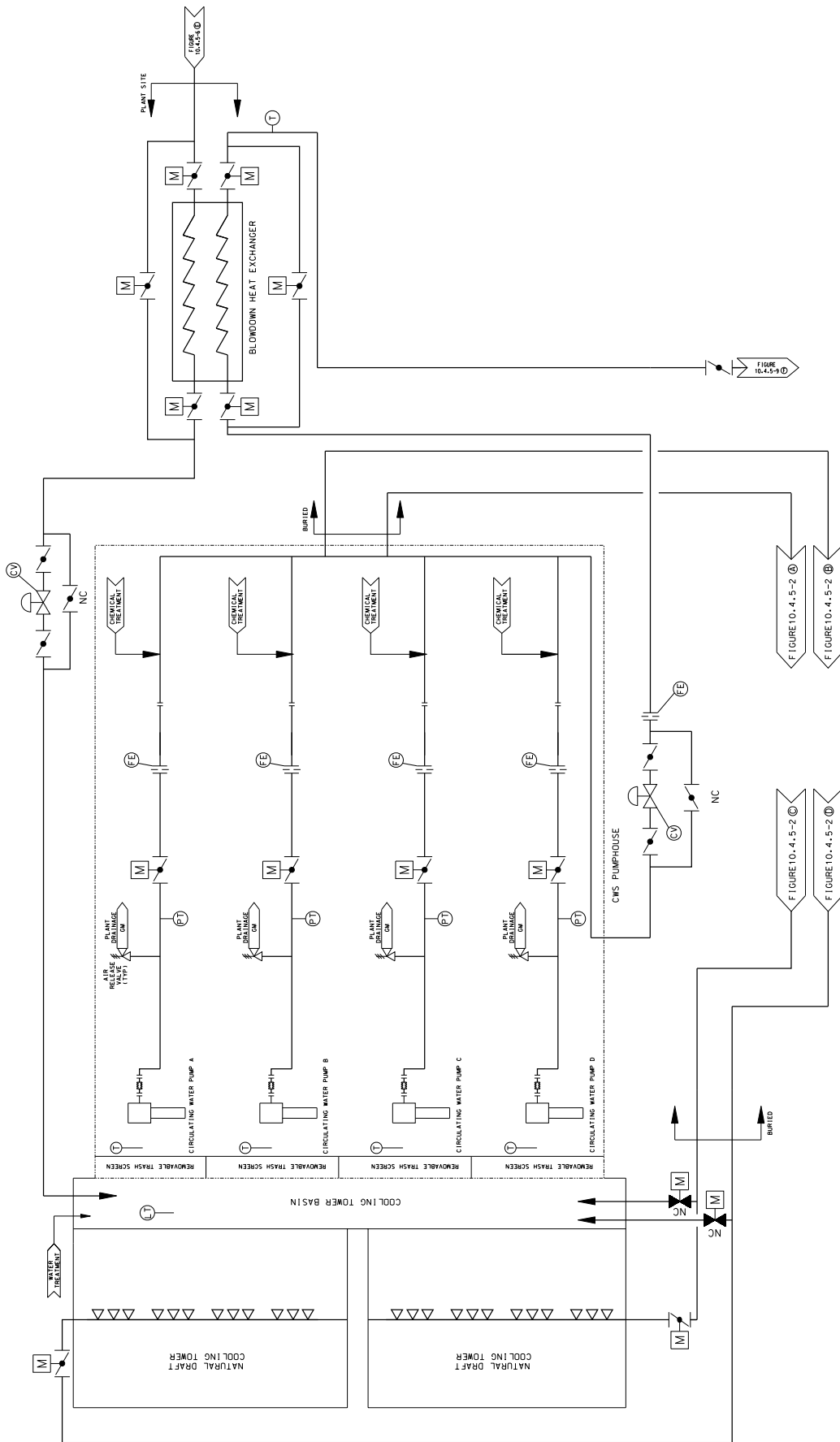

Figure 10.4-2—{CWS Pumphaouse (Plan View)}

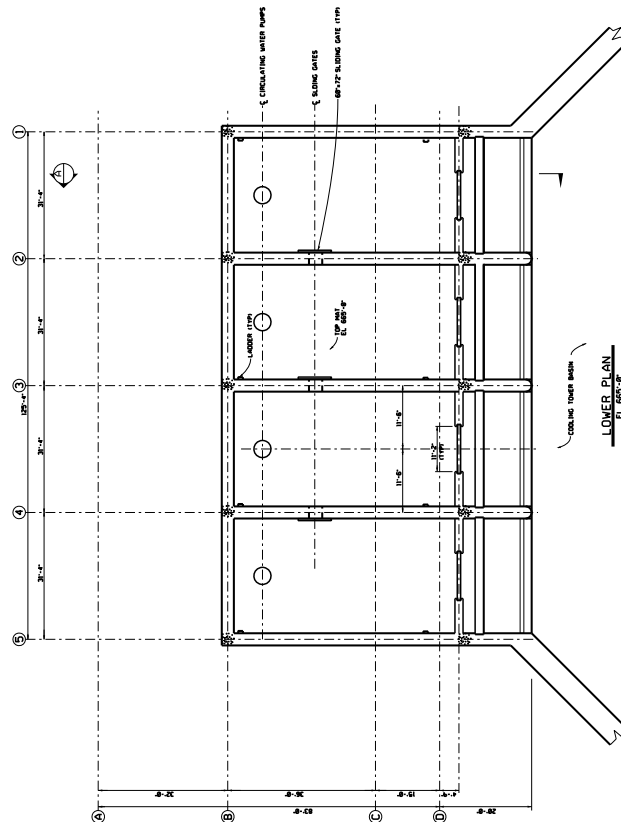
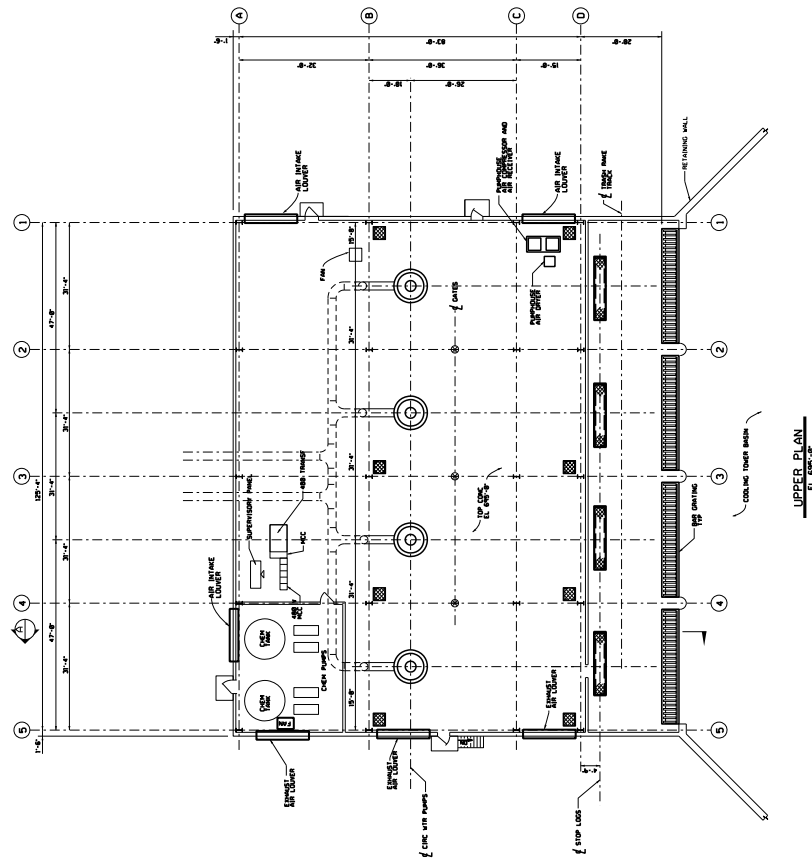

Figure 10.4-3—{CWS Pumphouse (Section View)}

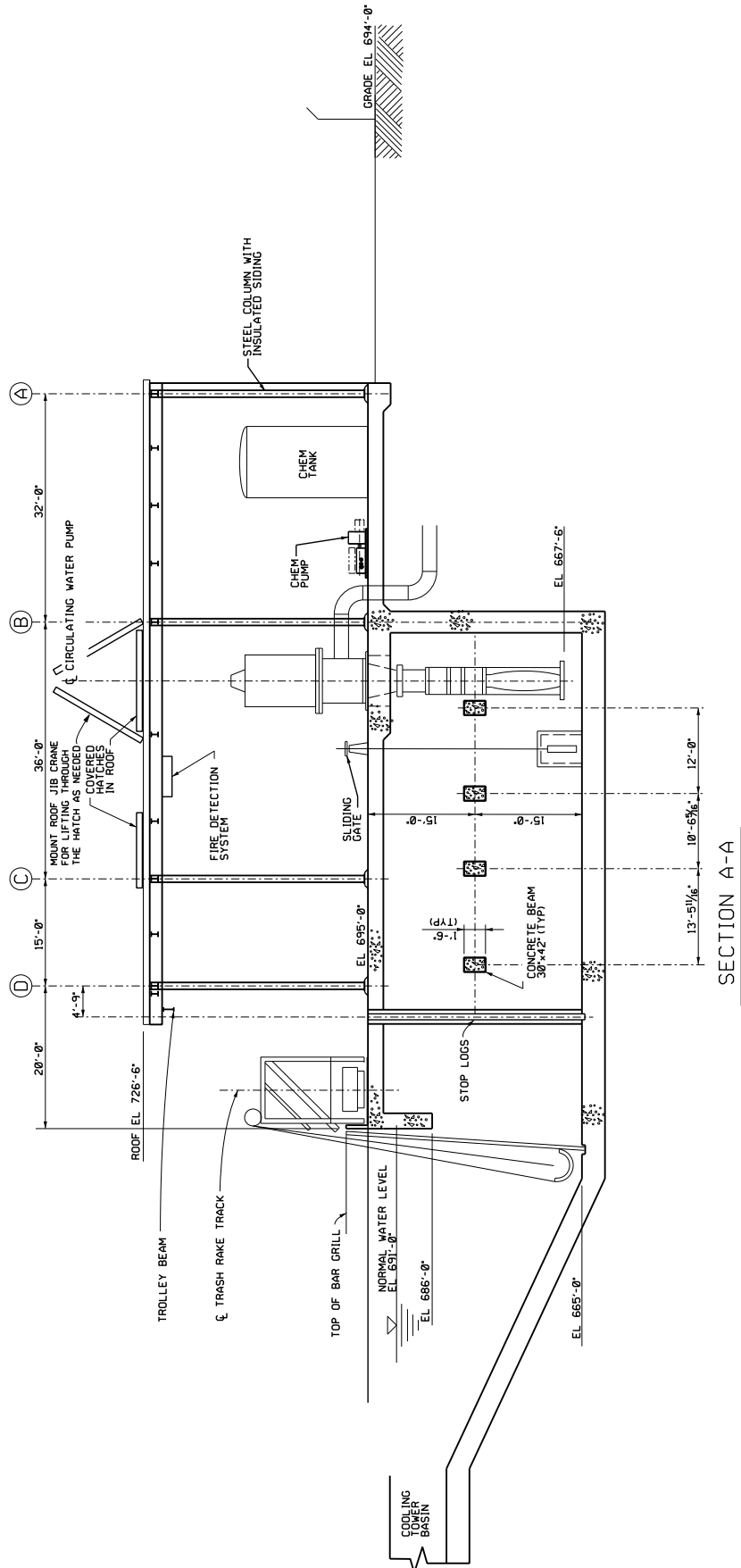

Figure 10.4-4—{Circulating Water System Cooling Tower}

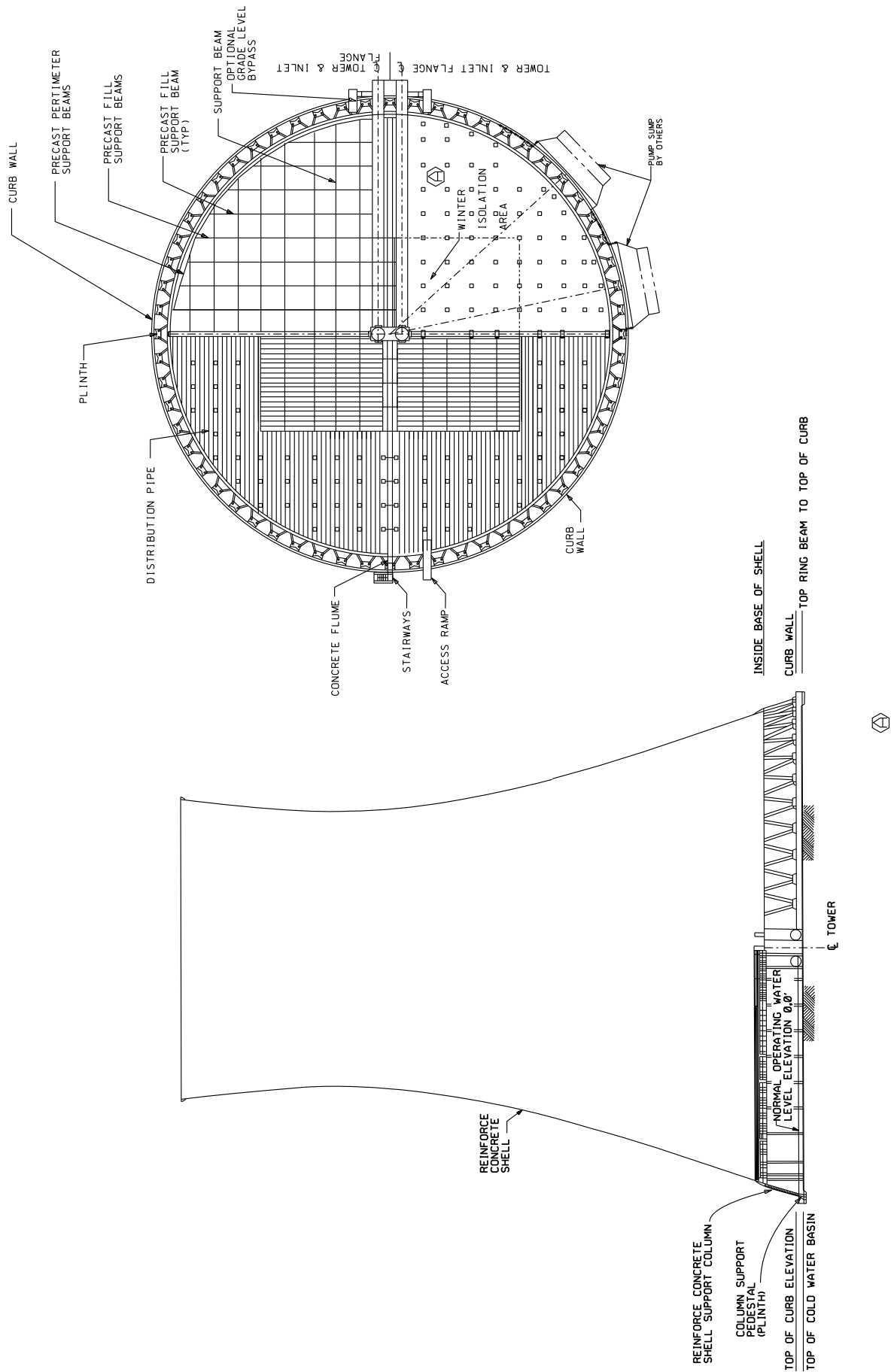

Figure 10.4-5—{CWS Makeup Water Intake Structure (Plan View)}

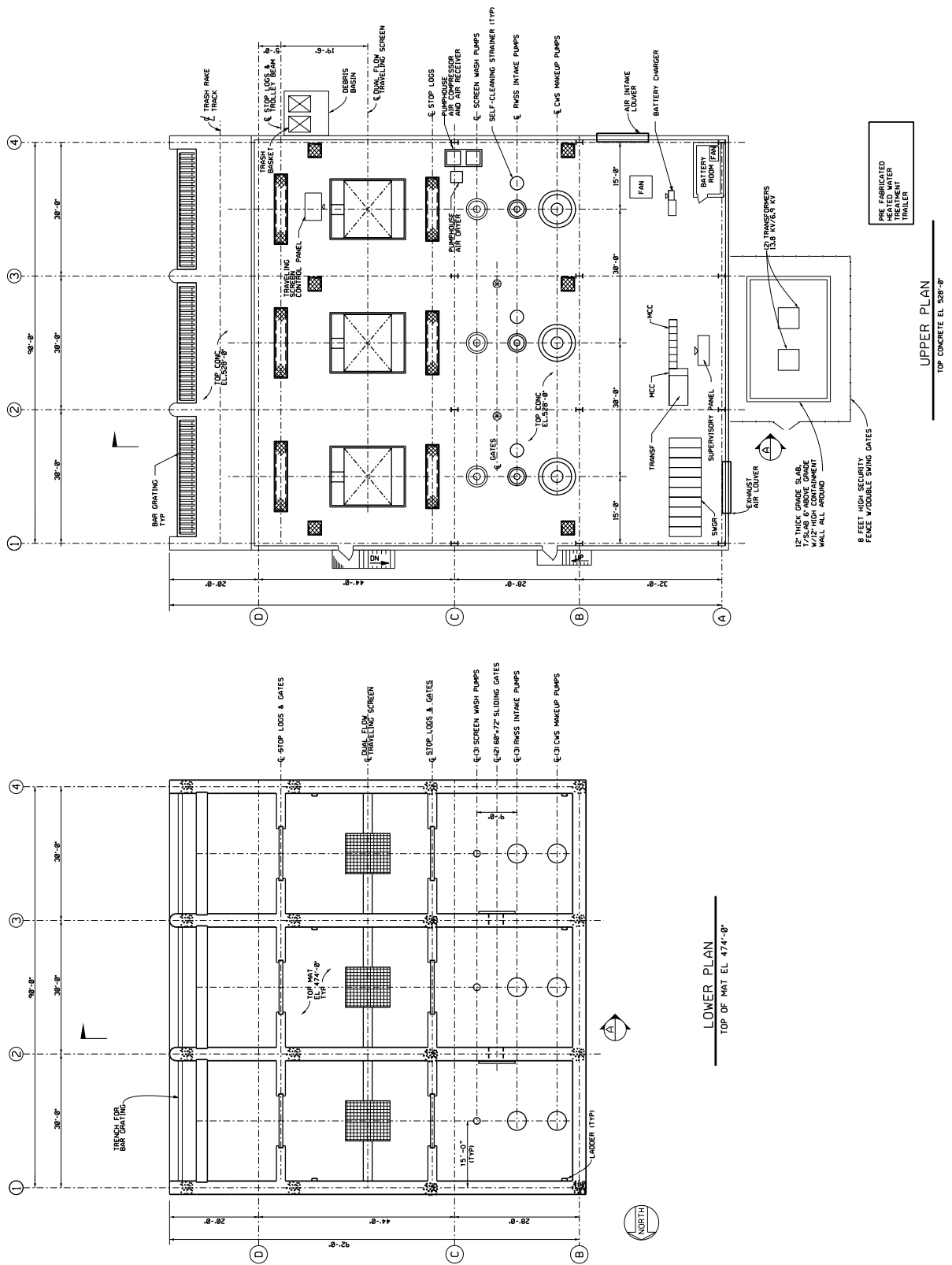

Figure 10.4.6—{Circulating Water System P&ID (Makeup System)}

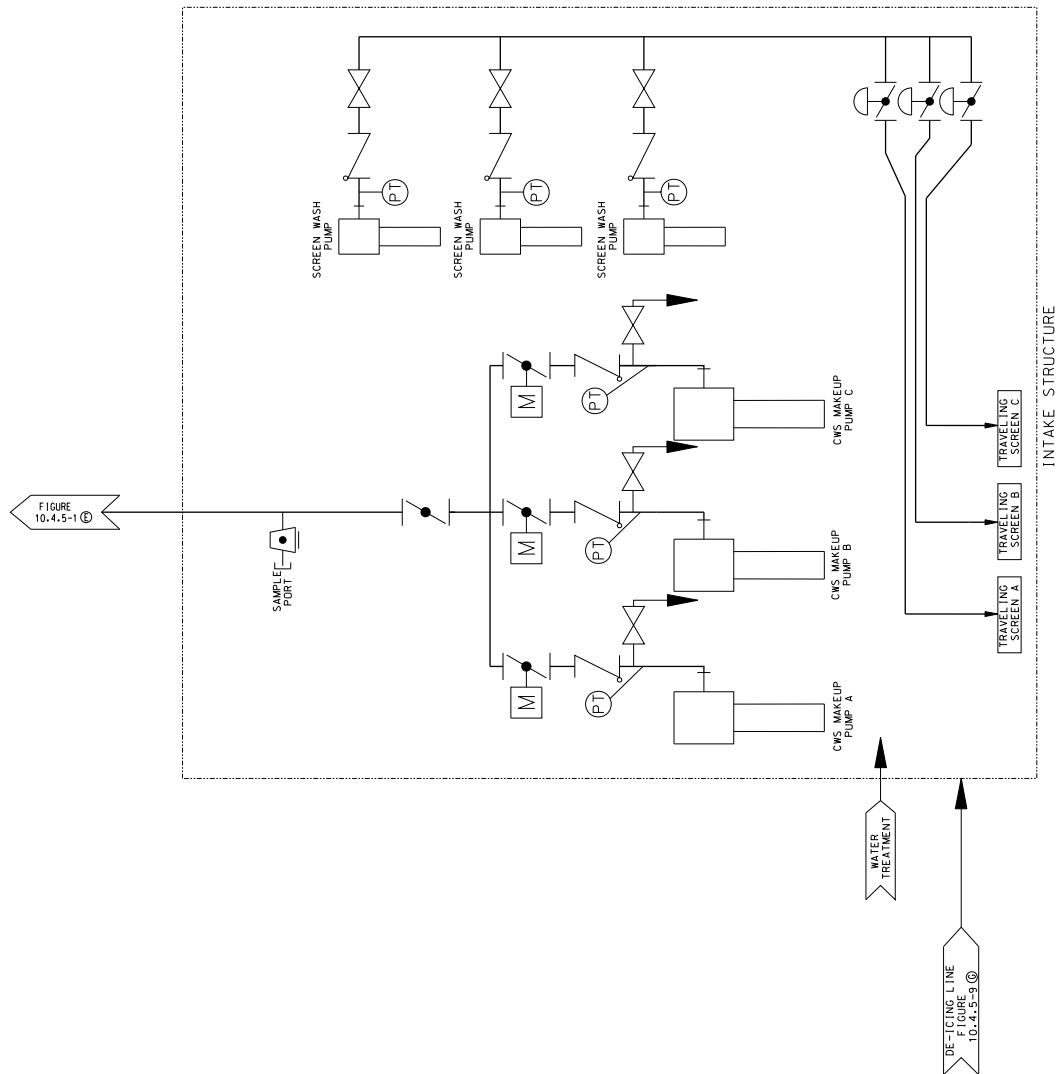
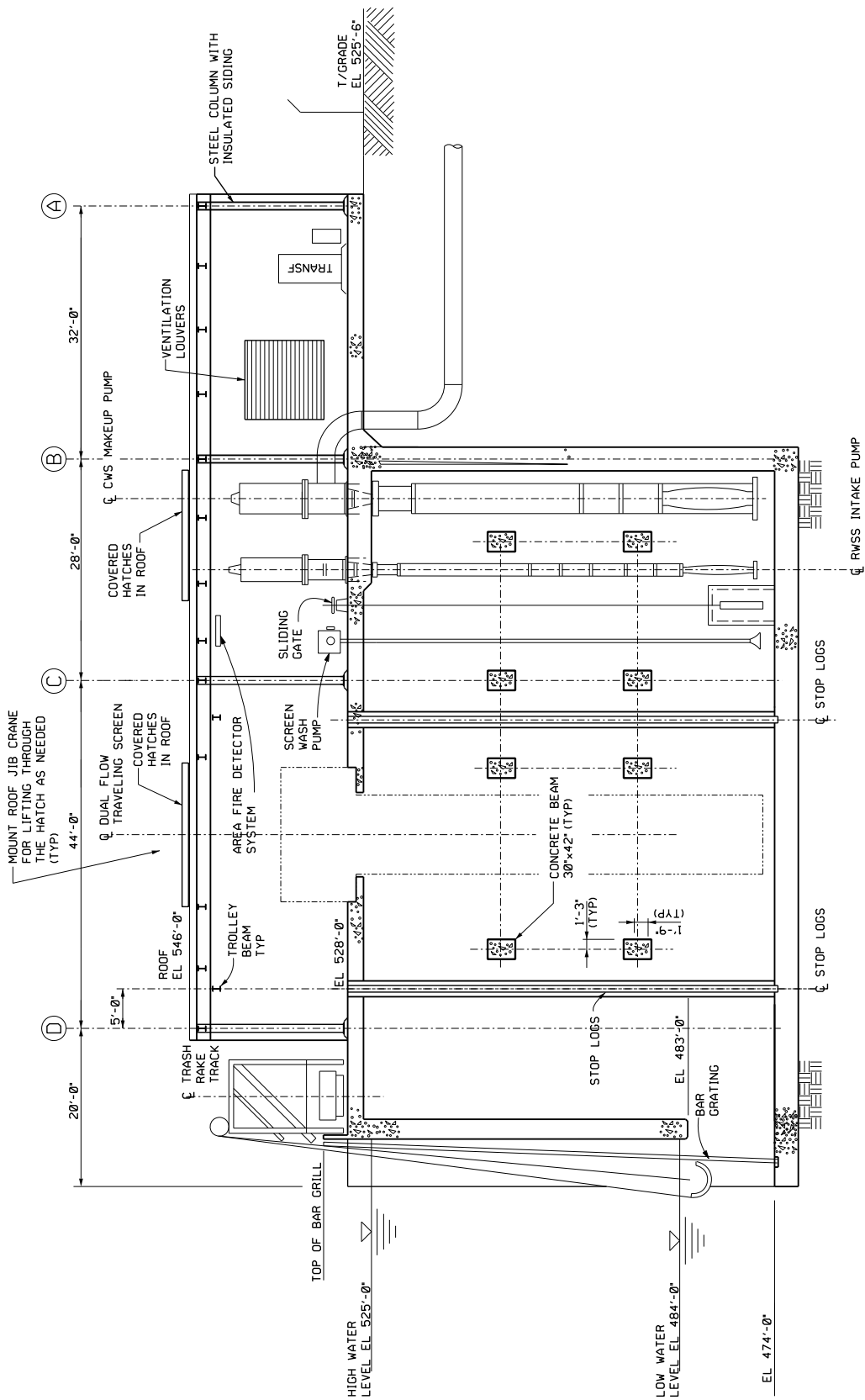

Figure 10.4-7—{CWS Makeup Water Intake Structure (Section View)}



SECTION A-A

Figure 10.4-8—{Circulating Water System P&ID (Blowdown System)}

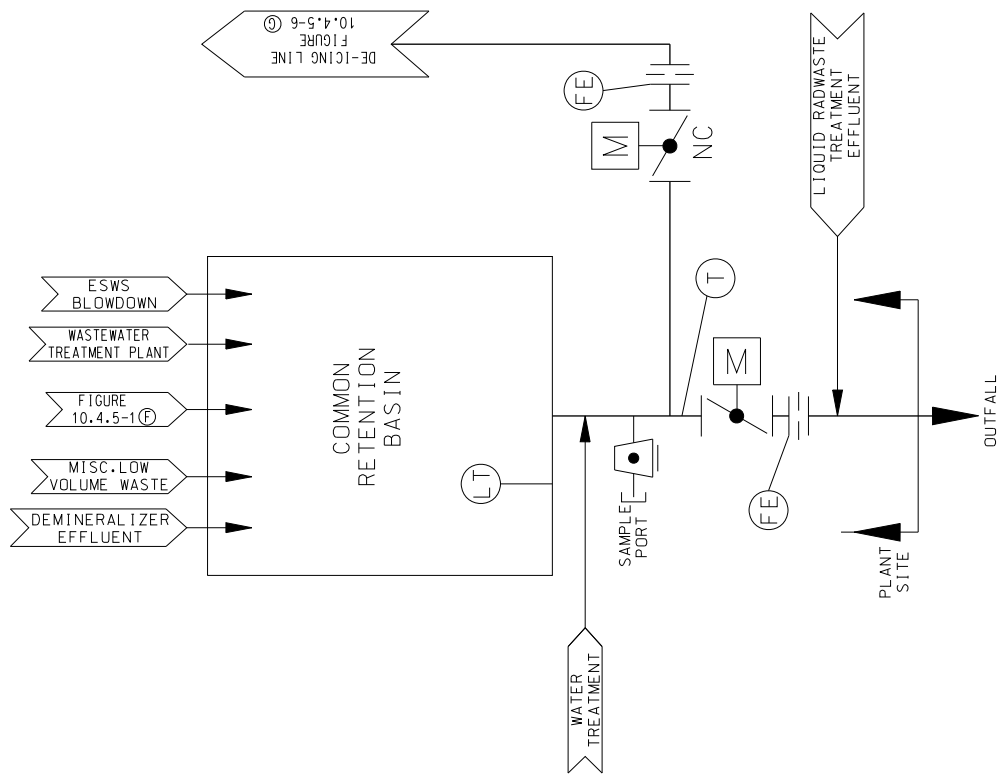

Figure 10.4.9—{Discharge Diffuser}

