

**PSEG Site
ESP Application
Part 5, Emergency Plan**

SECTION 6

NOTIFICATION METHODS - RESPONSE ORGANIZATIONS

1.0 INITIAL NOTIFICATION

1.1 PSEG EMERGENCY RESPONSE ORGANIZATION

The initial notification of an emergency or a change in emergency classification is in accordance with Figure 6-1. Table 6-1 provides an initial notification and action summary as discussed in NUREG-0654. The station plant paging systems are utilized to notify onsite personnel of emergency conditions and that activation of emergency response facilities may be required.

An automated Emergency Outdial System computer is utilized to callout the balance of emergency response personnel for full organizational augmentation and activation of emergency response facilities. The system activates the appropriate digital group pagers while simultaneously calling other personnel on the telephone. The system is interactive and recognizes emergency response personnel by their employee identification numbers.

Additional PSEG telephone notifications are made in accordance with applicable Event Classification Guide Attachments and Emergency Plan Implementing Procedures.

1.2 INITIAL NOTIFICATION - STATES

The initial notification to the states of an emergency or a change in emergency classification is made to the State Police Headquarters of New Jersey and Delaware. Upon completion of the initial message, each State Police Headquarters verifies the call by performing a callback check and then makes the notifications indicated in Figures 6-2 and 6-3.

The procedures for initial notifications to the State of New Jersey and Delaware are identical for all emergency classes. Once activated however, the Delaware Emergency Management Agency (DEMA) will take initial notifications instead of the Delaware State Police. This notification is made promptly following the declaration of the emergency (within 15 minutes). An example of the message format for this initial notification used in the emergency procedures is provided as Figure 6-4. These notifications meet the requirements of NUREG-0654, Element E-3. Appropriate forms are utilized for each emergency classification.

1.3 INITIAL NOTIFICATION - LOCAL

For events classified as an Unusual Event, Alert or Site Area Emergency classification, each state, following notification by PSEG, initially notifies the local authorities. If, however, PSEG has not been able to contact a state, PSEG directly notifies the local (county) authorities.

All initial notifications must be accomplished within 15 minutes. Accident assessment, protective action recommendations, and other information normally provided to the state are communicated to the local authorities (or other agencies as provided in the Memorandum of Understanding with the state) until the state assessment agency assumes its communications and assessment responsibilities.

For events classified as a General Emergency, PSEG makes direct contact with the States of New Jersey and Delaware. If the states cannot be contacted within fifteen minutes, PSEG notifies the local governments (counties) and the Coast Guard. Following this initial contact the states, or if

**PSEG Site
ESP Application
Part 5, Emergency Plan**

the states could not be contacted the counties, will be responsible for assessing the information provided, activating their response organization (as required), notifying appropriate local governments, and the public.

Following contact by the state, or PSEG, each county and the U.S. Coast Guard are responsible for assessing the information provided and activating their response organizations.

1.4 FOLLOWUP COMMUNICATION - STATES

The followup communication with the states is initiated by a return call from the authorized state agency. For the State of Delaware, the Delaware Emergency Management Agency is responsible for followup communications. For the State of New Jersey, the Department of Environmental Protection, Bureau of Nuclear Engineering and/or the New Jersey State Police Office of Emergency Management is responsible for followup communications.

The procedures for followup communications with the States of New Jersey and Delaware are identical for all emergency classes. An example message format for followup communications used in the emergency plan procedures is provided as Figure 6-5. These notifications meet the requirements of NUREG-0654, Element E-4. Appropriate forms are utilized for each emergency classification.

1.5 FOLLOWUP COMMUNICATIONS - LOCAL

Followup communications with the local authorities are provided by the appropriate state agency for all emergency classifications.

1.6 NOTIFICATION OF THE NRC

This plan provides for appropriate notification of the NRC for the events described in the Event Classification Guide.

2.0 PROMPT ALERTING AND NOTIFICATION OF THE PUBLIC

NOTE

The existing Salem and Hope Creek Generating Station Prompt Alerting and Notification System will be used by the PSEG Site. This system meets FEMA REP 10 requirements.

Following initial notification, the states make a determination on protective actions and activation of the Prompt Alerting and Notification System. This system can be activated directly by Salem County in New Jersey and by the Delaware State Police in Delaware for a rapidly developing emergency.

Land use within the PSEG Site plume exposure Emergency Planning Zone (EPZ) is principally rural. The area within five miles of the PSEG site is largely water and marsh land. This area attracts only a limited number of hunters and trappers, most of whom are local residents. The towns and city within ten miles of the PSEG Site are listed in Table 1-1.

**PSEG Site
ESP Application
Part 5, Emergency Plan**

2.1 SIREN SYSTEM AS THE FIRST PROMPT ALERTING SYSTEM

The Prompt Alerting and Notification System (operated by the states) (Figure 6-6) consists of subsystems which meet the criteria of FEMA REP-10. The system provides notification of the population within zero to five miles of the PSEG Site in 15 minutes and notification of the population within five to ten miles in 45 minutes. The first Prompt Alerting and Notification subsystem consists of a siren system controlled from a continuously (24 hour) staffed location in New Jersey and Delaware. Within zero to ten miles of the PSEG Site this system is designed to provide siren coverage for essentially 100% of the permanent resident population. In addition, it provides siren coverage of population centers throughout the plume exposure EPZ and selected coverage for the areas known to have recreational or transient populations. An area map showing this system is provided as Figure 6-7. Figure 6-7 includes a listing of siren locations. This system is as represented in the Alert and Notification System Report submitted by New Jersey, Delaware, and PSEG to FEMA Region 2 on January 31, 1986 and tested on December 10, 1986; as amended by the Final Design Review Report approved and issued by FEMA in April 2007 for the updated Alert and Notification System.

2.2 PUBLIC ADDRESS SYSTEMS AS THE SECOND PROMPT ALERTING SYSTEM

The second prompt alerting and notification subsystem combines alerting, notification, and information into a single system. This system, which is used for waterborne transient boaters within the plume exposure EPZ, consists of a radio alert and notification system coordinated by the United States Coast Guard (USCG) on Marine Channel 16 and supplemented by broadcasts via Emergency Alert System (EAS) and National Oceanographic and Atmospheric Administration (NOAA) Weather Radio. The USCG and states also dispatch boats and helicopters to make direct contact with boaters.

2.3 TRANSIENT ALERTING AND NOTIFICATION SYSTEM

Prompt alerting and notification of the transient population within the plume exposure EPZ utilizes the prompt alerting and notification system for the permanent resident population. The States of Delaware, New Jersey and the USCG have established methods for augmenting the prompt alerting and notification system that provides additional assurance that transients are notified in the event of an emergency requiring implementation of protective actions for the public. In general, the agencies in charge of parks and recreation, the Delaware National Guard, the marine police and the state police assist in the notification of transients within their jurisdictions. The alerting and notification of transients may utilize motor vehicles, aircraft, boats or road blocks. The methods used to inform/educate the transient population of the prompt alerting system and their required response is provided in Section 8.0 of this plan. These subsystems are augmented by the use of route alerting by police and fire personnel.

2.4 ROUTE ALERTING AS A BACK-UP ALERTING SYSTEM

The prompt alerting subsystems described previously are all augmented by the use of public address systems used by police and fire personnel.

2.5 ALERT NOTIFICATION SYSTEM REPORT

The Alert Notification System Report for Salem and Hope Creek Generating Stations, submitted to FEMA to meet REP 10 requirements, provides appropriate reports on the design, hardware, and other applicable components of the systems, including specific letters of agreement, plans and procedures.

**PSEG Site
ESP Application
Part 5, Emergency Plan**

**TABLE 6-1
NOTIFICATION AND ACTION SUMMARY**

A. Unusual Event

<u>Class/Condition</u>	<u>Licensee Actions</u>	<u>Offsite</u>
1. Potential degradation of the level of safety of the plant <u>OR</u> Security threat to facility protection.	1. Promptly inform DE DSP/DEMA and NJ OEM authorities.	1. Verify event classification/status.
2. No radiological release requiring offsite response or monitoring is expected.	2. Assess event conditions and initiate corrective actions. 3. Augment on-shift resources as needed. 4. Escalate emergency level or terminate the event.	2. Notify key personnel. 3. Provide assistance if requested. 4. Standby until termination.

**PSEG Site
ESP Application
Part 5, Emergency Plan**

**TABLE 6-1 (cont)
NOTIFICATION AND ACTION SUMMARY**

B. Alert

<u>Class/Condition</u>	<u>Licensee Actions</u>	<u>Offsite</u>
1. Potential/actual safety system degradation OR Security event that involves probable life threatening risk to site personnel or damage to site equipment because of hostile action.	1. Promptly inform DE DSP/DEMA and NJ OEM authorities.	1. Alert state response personnel & key county personnel.
2. Potential/actual radiological release is fraction of EPA PAG.	2. Activate the OSC.	2. Activate state EOC. Alert to standby/ activate Kent County, Cumberland County, New Castle County, and Salem County Emergency Coordinators.
	3. Mobilize additional personnel to activate TSC. Emergency Duty Officer assumes control as Emergency Coordinator. Provide periodic plant status updates to the states.	3. Initiate field monitoring, if appropriate.
	4. Assess event conditions & initiate corrective actions.	4. Escalate emergency level or terminate event.
	5. Dispatch field monitoring teams as applicable.	
	6. Provide states with escalated emergency level or terminate event.	

**PSEG Site
ESP Application
Part 5, Emergency Plan**

**TABLE 6-1 (cont)
NOTIFICATION AND ACTION SUMMARY**

C. Site Area Emergency

<u>Class/Condition</u>	<u>Licensee Actions</u>	<u>Offsite</u>
1. Actual/likely major failure of plant function needed to protect public OR Hostile action that results in intentional damage or malicious acts toward site personnel or equipment that could lead to likely failure of, or that prevents effective access to, equipment needed for protection of the public.	1. Promptly inform DE DSP/DEMA and NJ OEM authorities.	1. Initiate prompt notification and activate EAS and keep public informed.
2. Radiological release may exceed EPA PAG at site boundary.	2. Augment all resources to activate EOF. Emergency Response Manager assumes control as emergency coordinator.	2. Alert all emergency response personnel and activate specific functions. Activate state, county and local EOCs.
3. Possible degraded core.	3. Assess event conditions and initiate corrective actions.	3. Monitor appropriate locations.
4. Imminent loss of physical control of plant.	4. Conduct accountability and release nonessential personnel. 5. Dispatch radiological monitoring teams. 6. Provide states with: On/offsite radiological data, plant conditions, and meteorological data. 7. Provide state with dose projections and recommend protective actions. 8. Escalate or deescalate emergency class.	4. Alert contiguous and ingestion pathway states. 5. Provide assistance to the site, if required. 6. Escalate or deescalate emergency class.

**PSEG Site
ESP Application
Part 5, Emergency Plan**

**TABLE 6-1 (cont)
NOTIFICATION AND ACTION SUMMARY**

D. General Emergency

<u>Class/Condition</u>	<u>Licensee Actions</u>	<u>Offsite</u>
1. Actual/imminent core degradation or melting with potential containment failure OR Hostile actions that result in an actual loss of physical control of the facility.	1. Promptly inform DE DSP/DEMA and NJ OEM authorities. Provide pre-determined (based on plant condition) protective action recommendations.	1. Activate emergency and protective action functions.
2. Actual/potential radiological release exceeding EPA PAG offsite.	2. Assess event conditions and initiate corrective actions.	2. Make and implement protective actions, including pathway measures.
3. Loss of two fission Product barriers and Potential loss of the third.	3. Augment all Resources.	3. Regularly inform the public of Emergency status.
	4. Keep federal and state authorities informed of event status and developments.	4. Coordinate field monitoring with federal, offsite and onsite teams.
	5. Regularly provide radiological and meteorological data to the States.	5. Continuously assess event effects upon the public.
	6. Initiate actions, mitigate the incident and terminate any radiological releases.	6. Reduce emergency and initiate recovery action.
	7. Initiate recovery action and reduce emergency class.	

**PSEG Site
ESP Application
Part 5, Emergency Plan
FIGURE 6-1
NOTIFICATION METHOD - PSEG**

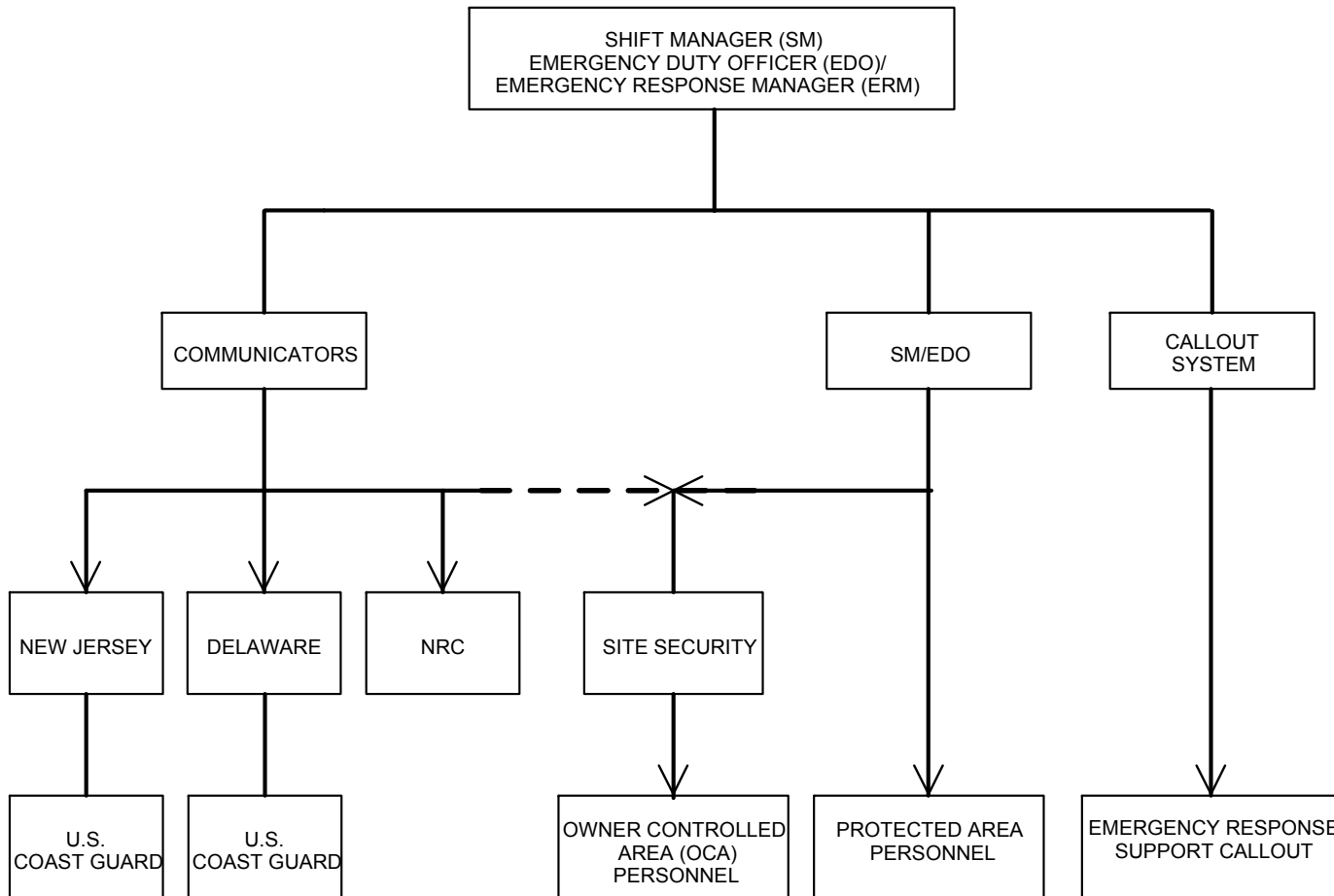

LEGEND

----- COMMUNICATOR NOTIFIES SITE SECURITY OF CLASSIFICATION ONLY, TO PREPARE THEM FOR PROTECTIVE ACTION DECISIONS COMING FROM THE OS/EDO.

**PSEG Site
ESP Application
Part 5, Emergency Plan**

**FIGURE 6-2
NOTIFICATION METHOD – NEW JERSEY**

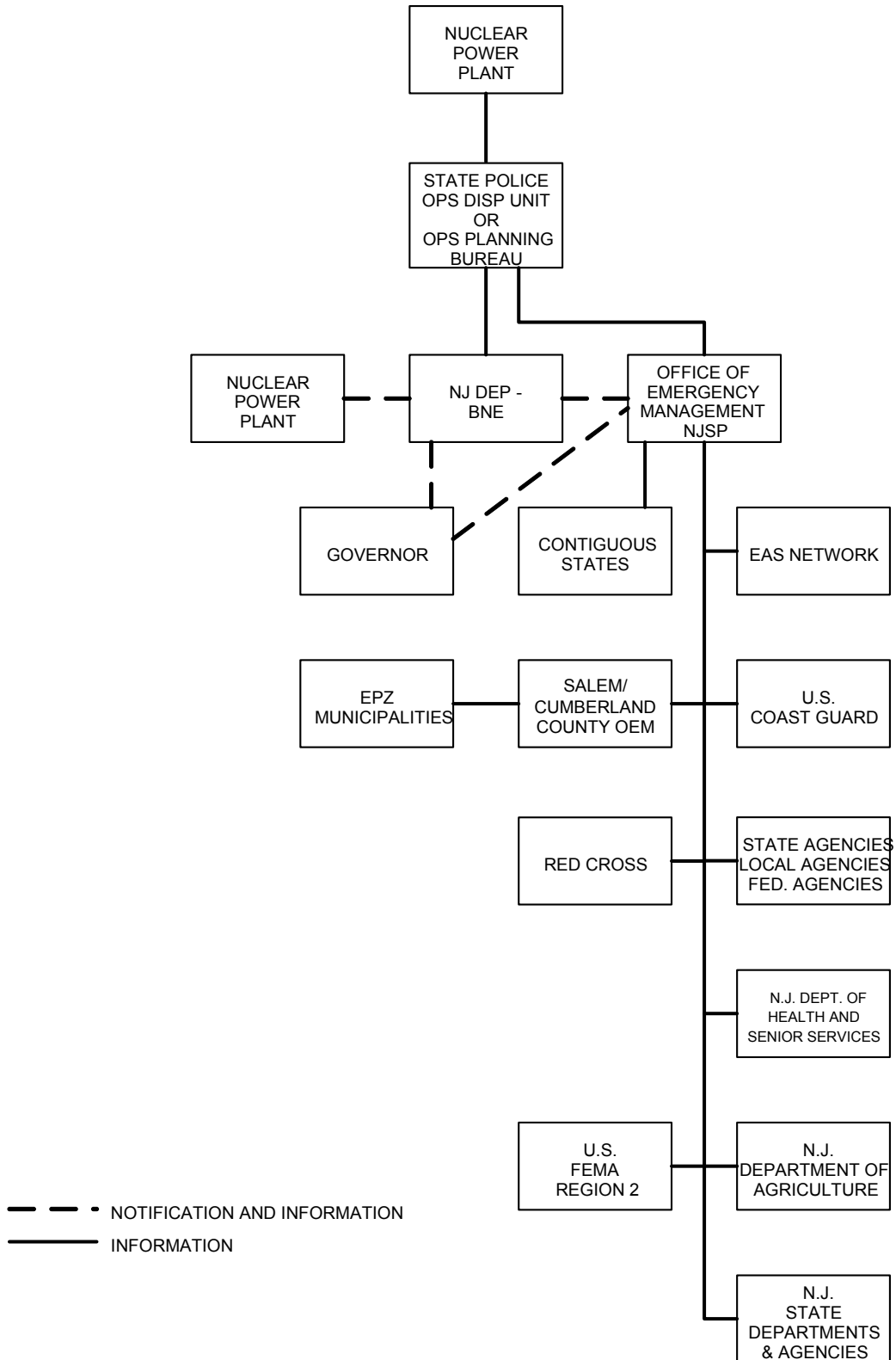

**PSEG Site
ESP Application
Part 5, Emergency Plan**

**FIGURE 6-3
NOTIFICATION METHOD – DELAWARE**

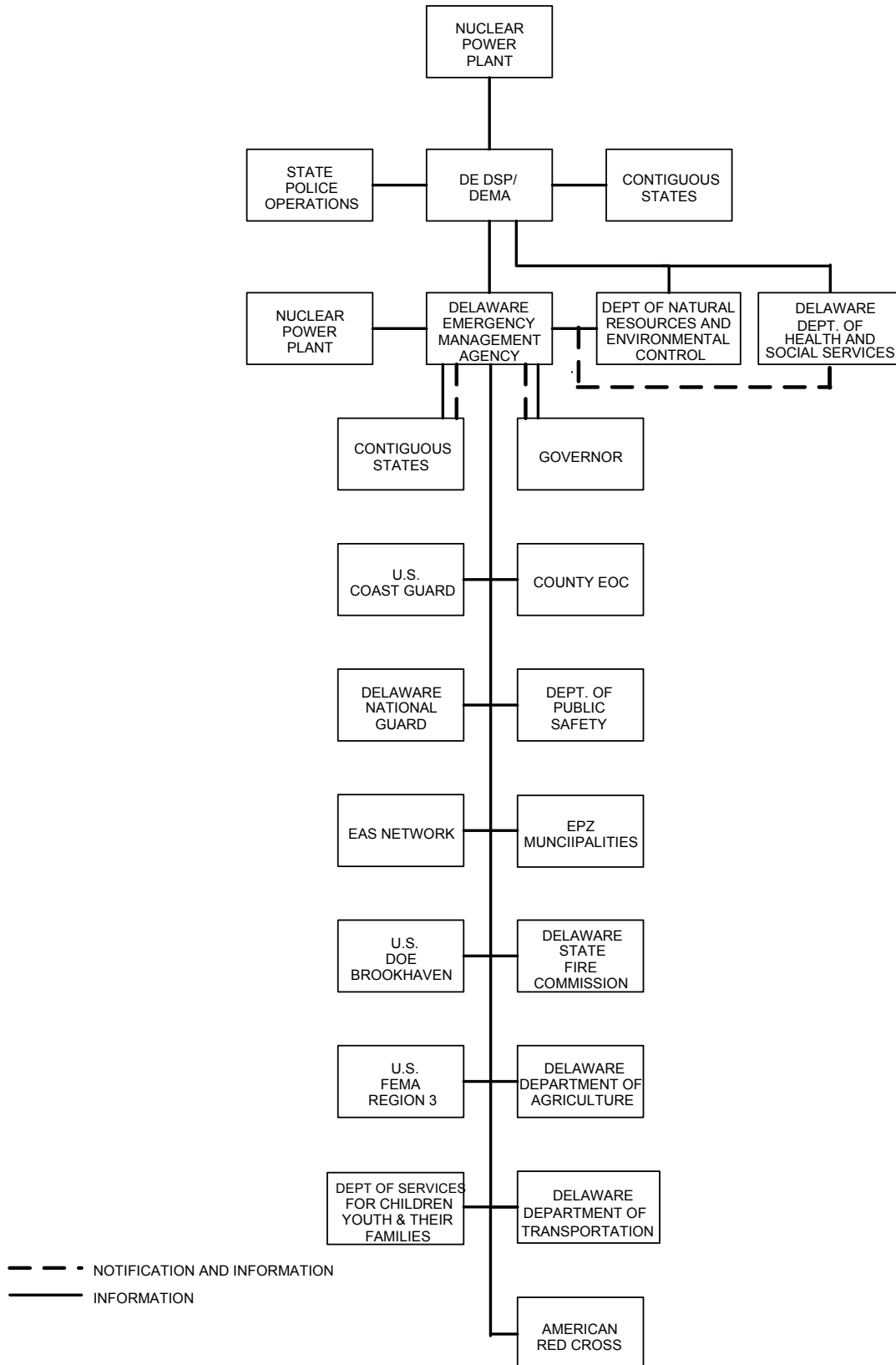

**PSEG Site
ESP Application
Part 5, Emergency Plan**

**FIGURE 6-4
TYPICAL INITIAL CONTACT MESSAGE FORM**

INITIAL CONTACT MESSAGE FORM

I. THIS IS _____, COMMUNICATOR IN THE CONTROL ROOM
(NAME) TSC
 EOF
AT THE **PSEG Site**, UNIT NO. _____.

II. THIS IS NOTIFICATION OF A **SITE AREA EMERGENCY** WHICH WAS
DECLARED AT _____ ON _____
(TIME - 24 HOUR CLOCK) (DATE)
EAL #(s) _____, _____, _____
DESCRIPTION OF EVENT: _____

III. NO RADIOLOGICAL RELEASE IS IN PROGRESS. } see NOTE
 THERE IS A RADIOLOGICAL RELEASE IN PROGRESS. } for release
definition

IV. 33 FT. LEVEL WIND DIRECTION (From): _____ WIND SPEED: _____
(From MET Computer) (DEGREES) (MPH)

V. **NO PROTECTIVE ACTIONS ARE RECOMMENDED AT THIS TIME**

EC Initials
(Approval to Transmit ICMF)

NOTE: Radiological Release is defined as: [To be determined after new plant data is available.]

**PSEG Site
ESP Application
Part 5, Emergency Plan**

**FIGURE 6-5 (cont)
TYPICAL STATION STATUS CHECKLIST**

**STATION STATUS CHECKLIST
(PAGE 2 OF 2)
RADIOLOGICAL INFORMATION**

PSEG SITE UNIT NUMBER: _____ CALCULATION TIME: _____ DATE: _____

1. GASEOUS RELEASE>TECH SPEC (T/S) LIMITS:

(T/S LIMITS: * IODINE)

YES: []

NO: []

RELEASE START TIME: _____ DATE: _____

A. RELEASE TERMINATED: YES [] NO [] N/A []

B. ANTICIPATED OR UNKNOWN DURATION OF RELEASE: _____ HOURS

C. TYPE OF RELEASE: GROUND [] ELEVATED: [] N/A []

D. ADJUSTED WIND SPEED: _____ (mph) _____ (m/sec) WIND DIR (deg from) _____

E. STABILITY CLASS: _____ (A-G) DELTA T: _____ (deg C)

F. VENT PATH OF RELEASE: * _____ * _____ * _____ * _____

G. NG RELEASE RATE: * _____ * _____ * _____ * _____
 _____ (μCi/sec)

H. I-131 RELEASE RATE: * _____ * _____ * _____ * _____
 _____ DEFAULT (μCi/sec) (circle if default)

I. TOTAL RELEASE RATE NOBLE GAS: _____ (μCi/sec)

J. TOTAL RELEASE RATE IODINE-131: _____ (μCi/sec)

2. PROJECTED OFFSITE DOSE RATE CALCULATIONS:

DISTANCE FROM VENT (IN MILES)	XU/Q (1/M2)	TEDE		THYROID-CDE RATE (MREM/HR)	THYROID-CDE DOSE (MREM)
		TEDE RATE (MREM/HR)	DOSE (4 DAY) (MREM)		
MEA *	_____	_____	_____	_____	_____
2.00	_____	_____	_____	_____	_____
LPZ 5.00	_____	_____	_____	_____	_____
EPZ 10.00	_____	_____	_____	_____	_____

[*: To be determined after new plant data is available.]

3. OTHER PERTINENT INFORMATION: _____

4. UPDATE TO STATES (IF VERBALLY TRANSMITTED):

	NAME	TIME	INITIALS
STATE OF NEW JERSEY:	_____	_____	_____
STATE OF DELAWARE :	_____	_____	_____
AGENCY:	_____	_____	_____

APPROVED: _____
 EC or RAC or RSM

**PSEG Site
ESP Application
Part 5, Emergency Plan**

**FIGURE 6-6
PROMPT NOTIFICATION SYSTEM**

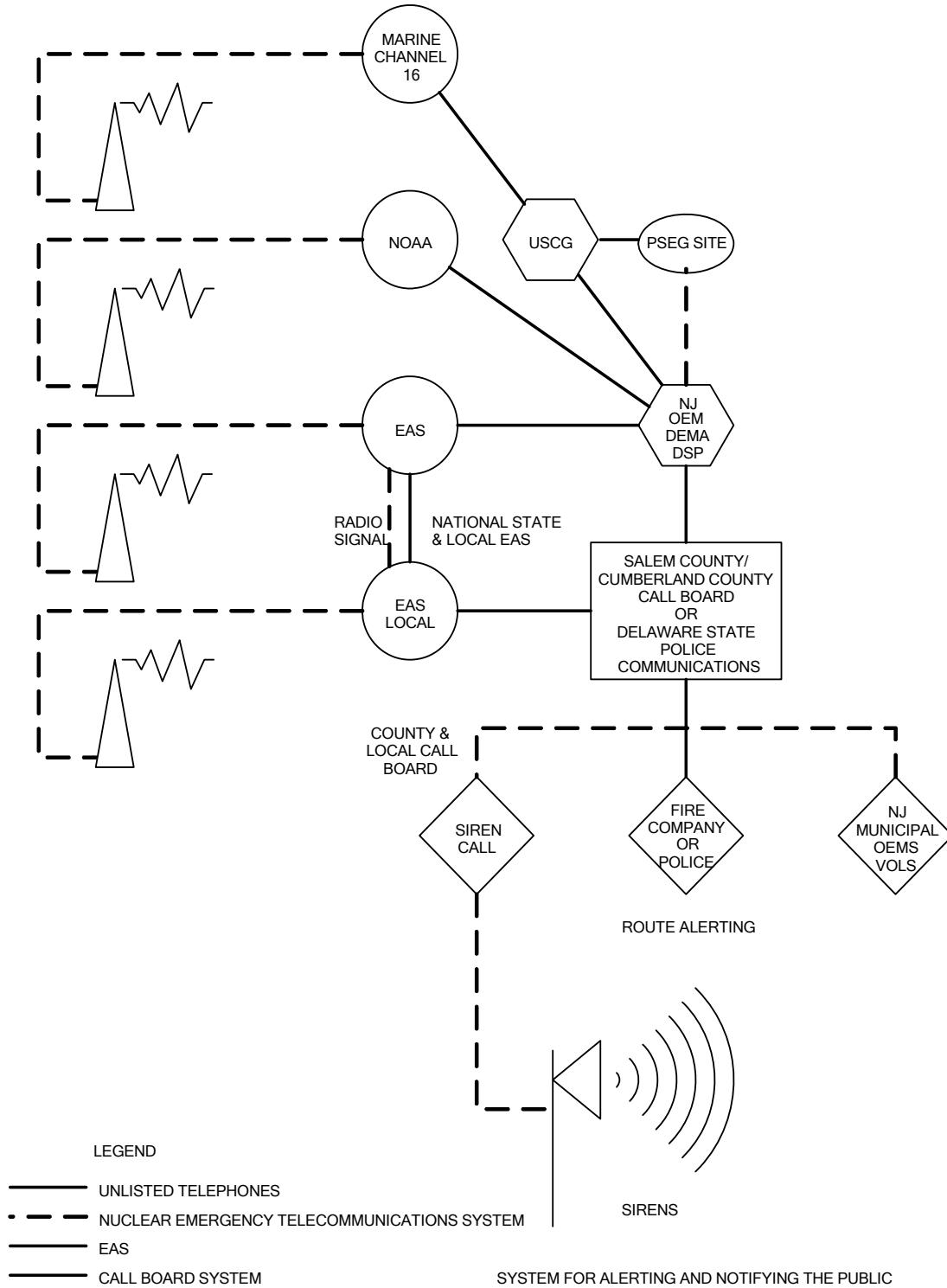

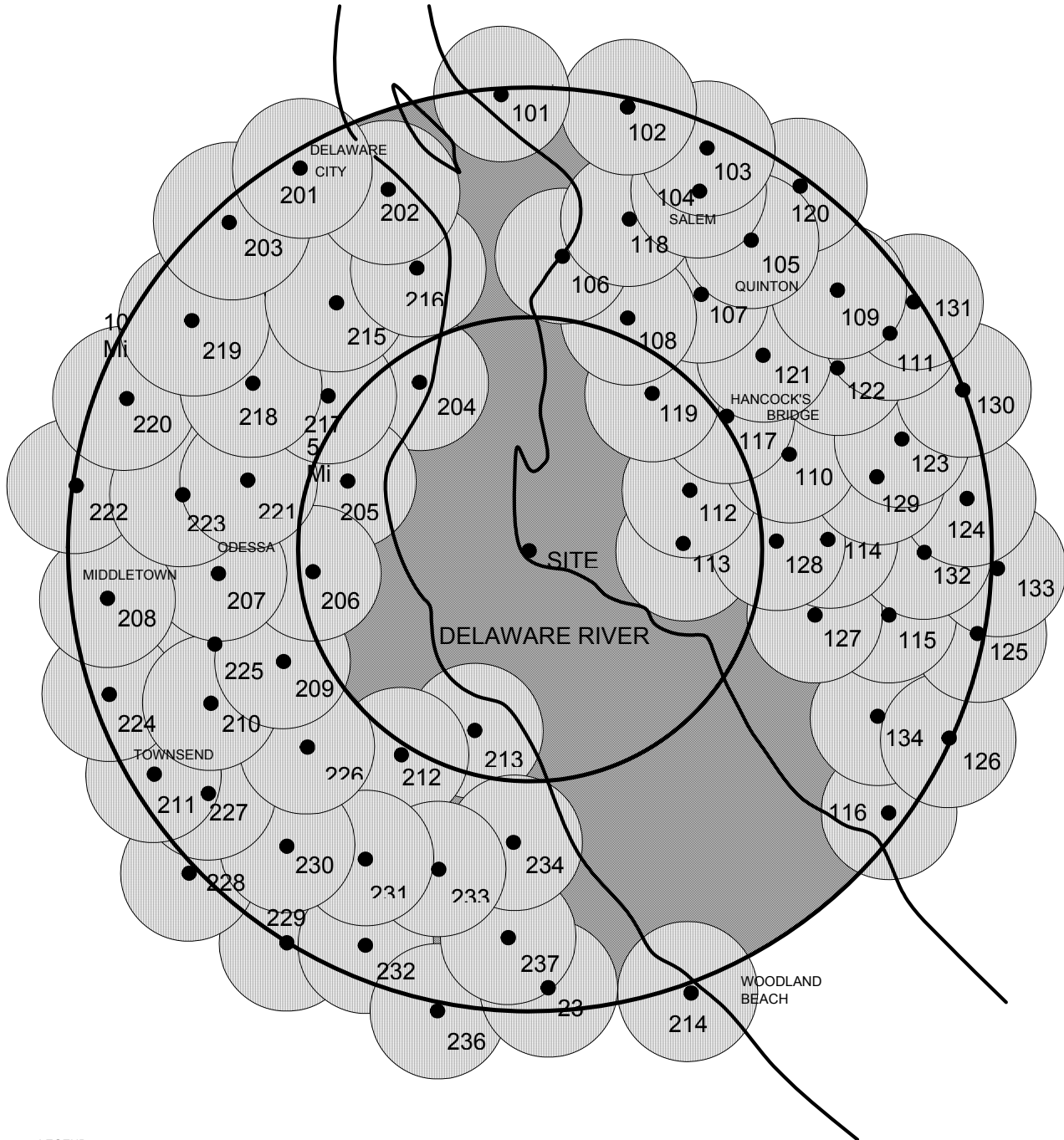

**PSEG Site
ESP Application
Part 5, Emergency Plan**

**FIGURE 6-7
APPROXIMATE AREA OF PROMPT NOTIFICATION SYSTEM COVERAGE**



LEGEND

SIREN COVERAGE 

MARINE NOTIFICATION AND EVACUATION 

KEY TO SIREN LOCATION NUMBERS FOLLOWS.

**PSEG Site
ESP Application
Part 5, Emergency Plan**

**FIGURE 6-7 (CONTINUED)
APPROXIMATE AREA OF PROMPT NOTIFICATION SYSTEM COVERAGE
SIREN LOCATIONS**

<u>Siren No.</u>	<u>State/City & County</u>	<u>Location</u>
<u>New Jersey</u>		
101	NJ/Pennsville Salem Co.	Fort Mott Road, 0.1 mile south of Fort Mott Park
102	NJ/Pennsville Salem Co.	Route 49, 1000 ft. south of intersection with Harrisonville Lighthouse Road
103	NJ/Salem Salem Co.	Route 45, 0.2 mile east of intersection with Tide Mill Road
104	NJ/Salem Salem Co.	New Market Street at intersection with Belden Street
105	NJ/Salem Salem Co.	Quinton Road, 0.2 mile west of intersection with Harris Road
106	NJ/Elsinboro Salem Co.	Delaware Avenue, 0.1 mile east of intersection with Locust Avenue
107	NJ/Haggerville Salem Co.	Salem-Hancocks Bridge Road, 1 mile from intersection with Amwellbury Road
108	NJ/Elsinboro Salem Co.	Fort Elfsborg-Hancocks Bridge Road, 1200 feet southeast of intersection with Money Island Road
109	NJ/Quinton Salem Co.	Quinton Fire Department, at intersection of Route 49 with Robinson Road
110	NJ/Lower Alloways Creek Salem Co.	Harmersville-Pecks Corner-Cohansy Road, 2000 feet east of intersection with Mays Lane
111	NJ/Quinton Salem Co.	Burden Hill Road, 3000 feet southwest of intersection with Route 49

**PSEG Site
ESP Application
Part 5, Emergency Plan**

**FIGURE 6-7 (CONTINUED)
APPROXIMATE AREA OF PROMPT NOTIFICATION SYSTEM COVERAGE
SIREN LOCATIONS**

<u>Siren No.</u>	<u>State/City & County</u>	<u>Location</u>
112	NJ/Lower Alloways Creek Salem Co.	Alloway Creek Neck Road, 2000 feet south of intersection with Grosscup Road on Access Road to Artificial Island
113	NJ/Lower Alloways Creek Salem Co.	Alloway Creek Neck Road, 1.8 mile south of intersection with Grosscup Road on Access Road to Artificial Island
114	NJ/Lower Alloways Creek Salem Co.	Frog Ocean Road, 1800 feet east of intersection with Stow Neck Road
115	NJ/Stow Creek Cumberland Co.	Stow Creek Road, 0.1 mile west of intersection with Canton Road
116	NJ/Greenwich Cumberland Co.	Bay Side Road, 1.1 mile west of intersection with Tindall Island Road
117	NJ/Lower Alloways Creek Salem Co.	Buttonwood Road at the intersection with Cuff Road
118	NJ/Elsinboro Salem Co.	Tilbury Road, 1500 feet south of the intersection with Sinnickson Landing Road
119	NJ/Elsinboro Salem Co.	Abbott's Farm Road, 4300 feet south of intersection with Fort Elfsborg-Hancocks Bridge Road
120	NJ/Salem Salem Co.	Quaker Neck Road at intersection with Sandy Ridge Road
121	NJ/Lower Alloways Creek Salem Co.	Beasley Neck Road, 2000 feet north of intersection with Hogate Boulevard

**PSEG Site
ESP Application
Part 5, Emergency Plan**

**FIGURE 6-7 (CONTINUED)
APPROXIMATE AREA OF PROMPT NOTIFICATION SYSTEM COVERAGE
SIREN LOCATIONS**

<u>Siren No.</u>	<u>State/City & County</u>	<u>Location</u>
122	NJ/Quinton Salem Co.	Cross Road, 500 feet south of intersection with Hogate Boulevard
123	NJ/Quinton Salem Co.	Quinton-Jericho Road at intersection with Mill Pond Road
124	NJ/Quinton Salem Co.	Quinton-Jericho Road, 500 feet northwest of inter section with Gravelly Hill Road
125	NJ/Stow Creek Cumberland Co.	Willis Road, 2500 feet east of Frank Davis Road South
126	NJ/Greenwich Cumberland Co.	Gum Tree Corner Road, 3250 feet south of intersection with Stathems Neck Road
127	NJ/Lower Alloways Creek Salem Co.	Frog Ocean Road at intersection with Frog Road
128	NJ/Lower Alloways Creek Salem Co.	Stow Neck Road, 0.5 mile south of intersection with Long Bridge Road
129	NJ/Lower Alloways Creek Salem Co.	Maskell's Mill Road at intersection with Batter Cake Lane
130	NJ/Quinton Salem Co.	Harmersville-Pecks Corner Cohansey Road, 3500 feet west of intersection with Route 49
131	NJ/Quinton Salem Co.	Burden Hill Road, 2000 feet north of intersection with Route 49
132	NJ/Lower Alloways Creek Salem Co.	Buckhorn Road, 8000 feet west of intersection with Macanippuck Road

**PSEG Site
ESP Application
Part 5, Emergency Plan**

**FIGURE 6-7 (CONTINUED)
APPROXIMATE AREA OF PROMPT NOTIFICATION SYSTEM COVERAGE
SIREN LOCATIONS**

<u>Siren No.</u>	<u>State/City & County</u>	<u>Location</u>
133	NJ/Stow Creek Salem Co.	Macanippuck Road, 2000 feet south of intersection with Buckhorn Road
134	NJ/Greenwich Cumberland Co.	Stathems Neck Road, 5500 feet west of intersection with Gum Tree Road at the bend in the road
<u>Delaware</u>		
201	DE/Delaware City New Castle Co.	Route 72 at intersection with Clarks Corner Road
202	DE/Delaware City New Castle Co.	Clinton St. at intersection with Second Street
203	DE/St. Georges New Castle Co.	Route 13 at intersection with Coxs Neck Lane
204	DE/Port Penn New Castle Co.	Biddles Corner-Port Penn Road, 0.1 mile west of intersection with River Road
205	DE/Bayview New Castle Co.	McDonough Bayview Road, 0.2 mile west of intersection with Thomas Corner Road
206	DE/Thomas Landing New Castle Co.	Thomas Corner Road, 0.8 mile west of intersection with Old Corbit Road
207	DE/Odessa New Castle Co.	Marl Pitt Road at intersection with Fifth Street
208	DE/Middletown New Castle Co.	Main Street at intersection with New Road
209	DE/Mathews Corners New Castle Co.	Stump Corner Road, 0.6 mile south of intersection with Thomas Corner Road

**PSEG Site
ESP Application
Part 5, Emergency Plan**

**FIGURE 6-7 (CONTINUED)
APPROXIMATE AREA OF PROMPT NOTIFICATION SYSTEM COVERAGE
SIREN LOCATIONS**

<u>Siren No.</u>	<u>State/City & County</u>	<u>Location</u>
210	DE/Fieldboro New Castle Co.	Noxontown Road, 0.1 mile west of intersection with Route 13
211	DE/Townsend New Castle Co.	Townsend Pine Tree Corner Road, 0.1 mile west of intersection with Blackbird Middletown Road
212	DE/Taylors Bridge New Castle Co.	Flemings Landing Road, 1.8 mile east of intersection with Taylors Bridge Road
213	De/Taylors Bridge New Castle Co.	Cedar Swamp Road, 2 miles east of Route 9
214	DE/Woodland Beach Kent Co.	Route 6, 2.8 miles east of intersection with Route 9
215	DE/Port Penn New Castle Co.	Route 9, 200 feet south of intersection with Dutch Neck Road
216	DE/Port Penn New Castle Co.	Dutch Neck Road, 9000 feet northeast of intersection with Biddles Corner- Port Penn Road
217	DE/Port Penn New Castle Co.	Boyd's Corner Road, 2000 feet west of intersection with Biddles Corner-Port Penn Road
218	DE/St. Georges New Castle Co.	Route 13, 2500 feet south of intersection with Biddles Corner-Port Penn Road
219	DE/Biddles Corner New Castle Co.	Biddles Corner Grove Road, 2600 feet north of intersection with County Road 412A
220	DE/Mt. Pleasant New Castle Co.	Ratlidge Road, 1500 feet north of intersection with Mount Pleasant-Boyd's Corner Road

**PSEG Site
ESP Application
Part 5, Emergency Plan**

**FIGURE 6-7 (CONTINUED)
APPROXIMATE AREA OF PROMPT NOTIFICATION SYSTEM COVERAGE
SIREN LOCATIONS**

<u>Siren No.</u>	<u>State/City & County</u>	<u>Location</u>
221	DE/McDonough New Castle Co.	Route 13, 1000 feet south of intersection with McDonough-Bayview Road
222	DE/Armstrong New Castle Co.	Route 301, 1500 feet north of intersection with Armstrong Corner Road
223	DE/Armstrong New Castle Co.	Shallcross Road, 5500 feet north of intersection with Armstrong Corner Road at bend in the road
224	DE/Middletown New Castle Co.	Blackbird-Middleton Road, 3000 feet south of intersection with Noxontown Road
225	DE/Fieldboro New Castle Co.	Route 13, 2000 feet north of intersection with Chestnut Lane
226	DE/Blackbird New Castle Co.	Taylors Bridge Road at intersection with Union Church Road
227	DE/Ginns Corner New Castle Co.	Route 13, 5000 feet north of intersection with Blackbird-Middletown Road
228	DE/Blackbird New Castle Co.	Blackbird Station Road, 800 feet west of Blackbird Creek
229	DE/Blackbird New Castle Co.	Route 13, 2950 feet south of intersection with Blackdiamond Road
230	DE/Blackbird New Castle Co.	Gum Bush Road, 2000 feet northeast of intersection with Blackbird Landing Road
231	DE/Walker New Castle Co.	Walker School Road at intersection with Gardner Road

**PSEG Site
ESP Application
Part 5, Emergency Plan**

**FIGURE 6-7 (CONTINUED)
APPROXIMATE AREA OF PROMPT NOTIFICATION SYSTEM COVERAGE
SIREN LOCATIONS**

<u>Siren No.</u>	<u>State/City & County</u>	<u>Location</u>
232	DE/Walker New Castle Co.	Paddock Road, 1750 feet north of intersection with Black Diamond and Walker School Roads
233	DE/Taylors Bridge New Castle Co.	Paddock Road, 3500 feet west of intersection with Route 9
234	DE/Taylors Bridge New Castle Co.	Thoroughfare Neck Road, 6000 feet east of intersection with Route 9
235	DE/Brick Store Kent Co.	County Road 82, 1000 feet south of intersection with Route 9
236	DE/Smyrna New Castle Co.	End of Brick Store Landing Road, 1500 feet east of intersection with County Road 503
237	DE/Brickstore Kent Co.	Route 9, 2000 feet northwest of intersection with County Road 317

NOTE:

All sirens are omni-directional and each has a weighted average sound pressure level of 119.5 dB[©] at 100 feet to meet criteria of FEMA REP-10.