

PMSTPCOL PEmails

From: Tomkins, James [jjetomkins@STPEGS.COM]
Sent: Wednesday, March 31, 2010 10:41 AM
To: Muniz, Adrian; Dyer, Linda; Wunder, George; Tonacci, Mark; Eudy, Michael; Kallan, Paul; Plisco, Loren; Anand, Raj; Foster, Rocky; Joseph, Stacy; Govan, Tekia; Tai, Tom
Subject: Transmittal of Letter U7-C-STP-NRC-100064
Attachments: U7-C-STP-NRC-100064.pdf

Please find attached a courtesy copy of letter number U7-C-STP-NRC-100064, which contains the response to NRC staff questions included in Request for Additional Information (RAI) letter numbers 285 and 395 related to Combined License Application (COLA) Part 2, Tier 2, Appendices 15E and 6C.

The official version of this correspondence will be placed in the mail. Please call James E. Tomkins at 805-215-6129 if you have any questions concerning this letter.

Hearing Identifier: SouthTexas34Public_EX
Email Number: 2054

Mail Envelope Properties (582CA7E05607F14F8D433C5CE43C030A019E50828E)

Subject: Transmittal of Letter U7-C-STP-NRC-100064
Sent Date: 3/31/2010 10:40:51 AM
Received Date: 3/31/2010 10:41:09 AM
From: Tomkins, James

Created By: jetomkins@STPEGS.COM

Recipients:

"Muniz, Adrian" <Adrian.Muniz@nrc.gov>
Tracking Status: None
"Dyer, Linda" <ldyer@STPEGS.COM>
Tracking Status: None
"Wunder, George" <George.Wunder@nrc.gov>
Tracking Status: None
"Tonacci, Mark" <Mark.Tonacci@nrc.gov>
Tracking Status: None
"Eudy, Michael" <Michael.Eudy@nrc.gov>
Tracking Status: None
"Kallan, Paul" <Paul.Kallan@nrc.gov>
Tracking Status: None
"Plisco, Loren" <Loren.Plisco@nrc.gov>
Tracking Status: None
"Anand, Raj" <Raj.Anand@nrc.gov>
Tracking Status: None
"Foster, Rocky" <Rocky.Foster@nrc.gov>
Tracking Status: None
"Joseph, Stacy" <Stacy.Joseph@nrc.gov>
Tracking Status: None
"Govan, Tekia" <Tekia.Govan@nrc.gov>
Tracking Status: None
"Tai, Tom" <Tom.Tai@nrc.gov>
Tracking Status: None

Post Office: exgmb2.CORP.STPEGS.NET

Files	Size	Date & Time
MESSAGE	471	3/31/2010 10:41:09 AM
U7-C-STP-NRC-100064.pdf	241519	

Options

Priority: Standard
Return Notification: No
Reply Requested: No
Sensitivity: Normal
Expiration Date:
Recipients Received:



South Texas Project Electric Generating Station P.O. Box 289 Wadsworth, Texas 77483

March 30, 2010
U7-C-STP-NRC-100064

U. S. Nuclear Regulatory Commission
Attention: Document Control Desk
One White Flint North
11555 Rockville Pike
Rockville, MD 20852-2738

South Texas Project
Units 3 and 4
Docket Nos. 52-012 and 52-013
Response to Requests for Additional Information

Attached are responses to NRC staff questions included in Request for Additional Information (RAI) letter numbers 285 and 395 related to Combined License Application (COLA) Part 2, Tier 2, Appendices 6C and 15E. This completes the response to these letters. The attachments address the responses to the RAI questions listed below:

RAI 15.08-2 Revision 1
RAI 06.02.02-26

The COLA changes provided in these responses will be incorporated in the next routine revision of the COLA following NRC acceptance of the RAI response.

There are no commitments in this letter.

If you have any questions regarding these responses, please contact me at (361) 972-7136, or Bill Mookhoek at (361) 972-7274.

I declare under penalty of perjury that the foregoing is true and correct.

Executed on 3/30/10



Scott Head
Manager, Regulatory Affairs
South Texas Project Units 3 & 4

jet

Attachments:

1. RAI 15.08-2 Revision 1
2. RAI 06.02.02-26

cc: w/o attachment except*
(paper copy)

Director, Office of New Reactors
U. S. Nuclear Regulatory Commission
One White Flint North
11555 Rockville Pike
Rockville, MD 20852-2738

Regional Administrator, Region IV
U. S. Nuclear Regulatory Commission
611 Ryan Plaza Drive, Suite 400
Arlington, Texas 76011-8064

Kathy C. Perkins, RN, MBA
Assistant Commissioner
Division for Regulatory Services
P. O. Box 149347
Austin, Texas 78714-9347

Alice Hamilton Rogers, P.E.
Inspections Unit Manager
Texas Department of Health Services
P. O. Box 149347
Austin, Texas 78714-9347

C. M. Canady
City of Austin
Electric Utility Department
721 Barton Springs Road
Austin, TX 78704

*Steven P. Frantz, Esquire
A. H. Gutterman, Esquire
Morgan, Lewis & Bockius LLP
1111 Pennsylvania Ave. NW
Washington D.C. 20004

*Paul Kallan
*Adrian Muniz
Two White Flint North
11545 Rockville Pike
Rockville, MD 20852

(electronic copy)

*George F. Wunder
*Paul Kallan
*Adrian Muniz
Loren R. Plisco
U. S. Nuclear Regulatory Commission

Steve Winn
Joseph Kiwak
Eli Smith
Nuclear Innovation North America

Jon C. Wood, Esquire
Cox Smith Matthews

J. J. Nestrsta
Kevin Pollo
L. D. Blaylock
CPS Energy

RAI 15.08-2 Revision 1**QUESTION:**

STPNOC has revised the logic in the STP 3 & 4 FSAR Figures 15E-1a, "ATWS Mitigation Logic (ARI, FMCRD Run-In, RPT, Manual Initiation)," 15E-1b, "ATWS Mitigation Logic (SLCS Initiation, Feedwater Runback)," and 15E-1c, "ATWS Mitigation logic (SLCS Initiation, Feedwater Runback)" based on Tier 1 departure STD DEP T1 3.4-1 and STD DEP Admin. However, no changes have been made to the ATWS logic-related text contained in the FSAR, specifically subsections 2.2.8 and 3.4 in Tier 1, and subsection 7.4 and 15E.1 in Tier 2. Explanation of the logic changes shown on these revised FSAR figures has not been provided in either of the cited departures. It was also noted that some of the changes made to these FSAR figures are not annotated (back circled). Due to the stated reasons, NRC staff is unable to verify the acceptability of the departed ATWS mitigation logic. STPNOC is asked to provide an explanation for all marked and unmarked logic changes shown on the revised FSAR figures 15E-1a, 15E-1b, and 15E-1c.

REVISED RESPONSE:

STPNOC letter U7-C-STP-NRC-090207, dated December 7, 2009 provided the original response to RAI 15.08-2. The response provided below replaces the original response in its entirety.

Figure 15E-1a

No changes are required to this figure. All changes are associated with STD DEP T1 3.4-1 and are properly identified.

Figure 15E-1b

The following changes are made to DCD Figure 15E-1b. An administrative change is made to the manual ATWS "A" & "B" initiation logic to show 2 out of 3 voting signals. This logic change to the DCD figure is correct with respect to the DCD design; however, it was not properly identified as a change on the previous COLA figure, and will be identified in a future COLA revision as shown below. This logic design is consistent with DCD Part 2, Tier 1, Sections 2.2.4 and 3.4 and Part 2, Tier 2, Subsection 7.4.1.2. An additional administrative change is made to correct the figure number in the title.

A change is made to COLA Revision 3, FSAR Figure 15E-1b to show the DCD NMS SRNM ATWS permissive 2-out-of-4 logic design. This change is also an administrative change for consistency with DCD Part 2, Tier 1, Sections 2.2.4 and 3.4 and Part 2, Tier 2, Subsection 7.6.1.1.

There are several additional changes related to the nomenclature changes identified in standard departure STD DEP T1 3.4-1. The nomenclature for trip logic units (TLUs) has changed to trip logic functions (TLFs), so "SSLC TLU" in Figure 15E-1b Note 2 becomes "TLF". Also, as discussed in STPNOC's RAI 07.02-2 response, the same departure eliminates the SSLC bypass unit as a separate entity; the logic for this unit has been incorporated in the Reactor Trip and Isolation System (RTIS).

Figure 15E-1c

No changes are required to this figure. All changes are associated with STD DEP T1 3.4-1 and are properly identified.

COLA Part 2, Chapter 15, Figure 15E-1b will be revised as shown below in COLA Revision 4. All changes are shown relative to the DCD. Corresponding changes to the associated ATWS Technical Specification figures will also be made in COLA Revision 4.

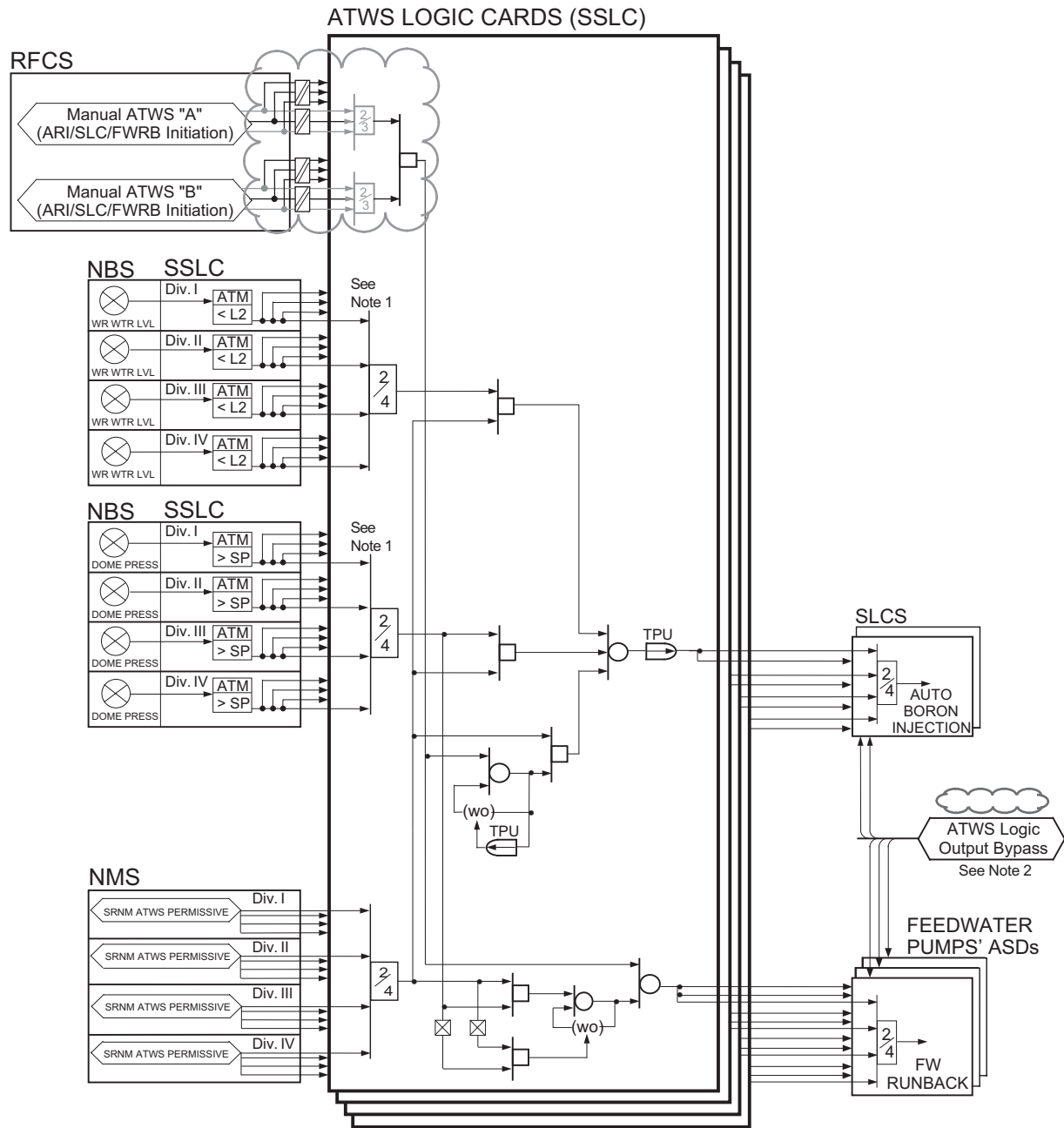

NOTES:

1. SSLC DIVISION-OF-SENSORS BYPASS APPLIES TO THIS VOTER
2. SAME ARRANGEMENT AS TLU OUTPUT LOGIC BYPASS BUT PERFORMED INDEPENDENTLY

Figure 15E-1b ATWS Mitigation Logic (SLCS Initiation, Feedwater Runback)

RAI 06.02.02-26**QUESTION:**

In RAI 6.2.2-6, the staff requested the applicant to explain how it accounted for miscellaneous debris (equipment tags, tape, and stickers or placards affixed by adhesives). In response, in a letter, dated September 28, 2009, the applicant stated that based on operating experience at STP 1&2 (operating PWR), each strainer will be assumed to have the openings of 2 cassettes blocked by miscellaneous latent debris, e.g., small pieces of plastic, tape, sheets of paper, and health physics low dose sign. Considering that following a LOCA 2 RHR pumps and 1 HPCF pump will be in operation and that each pump has two strainers, the total area of strainers blocked would be equal to 0.74 m^2 (8 ft^2). The staff noted that STP 1&2 have assumed a significantly higher area for miscellaneous latent debris (7.0 m^2 (75 ft^2) being transported to the sump) (GSI-191 Program: GL-04-02 Second Response, dated August 31, 2005).

Justify your basis for assuming 2 cassettes per strainer are blocked by miscellaneous latent debris.

RESPONSE:

As noted in the question, two filter pockets per strainer, which is approximately a total of 8 ft^2 of strainer area for all strainers, is assumed to be unavailable for the STP 3&4 ECCS pump suction strainers as a result of blockage due to miscellaneous latent debris such as equipment tags, tape, and stickers. This assumption is bounded by the results of a suppression pool inspection that was conducted on a Japanese operating ABWR following a two-year operating interval. (There is no record of debris found following the first operating period.) The results of that inspection, which are documented in STPNOC report STPTEP-2-023 titled "Report on Task Order for the South Texas Project Units 3&4 ABWR Construction Project", show that a total of approximately 3.2 ft^2 of miscellaneous tape fragments and plastic sheet was found in the suppression pool. Of that total, 2.7 ft^2 was one item. No miscellaneous items were reported in the drywell. Note that the suppression pool cleanup system (SPCU) was operated prior to the refueling outage in which this inspection was made. However, as noted in STP 3&4 COLA FSAR Subsection 6.2.1.7.1.5 in the markup attached to the response to RAI 06.02.02-5 (transmitted via STPNOC Letter No. U7-C-STP-NRC-090141 on September 28, 2009):

"... a remote visual inspection will be performed of the Residual Heat Removal (RHR), Reactor Core Isolation Cooling (RCIC), and High Pressure Core Flooder (HPCF) suction strainers and the S/P floor to ensure there is no debris present. This inspection will be focused on the presence of debris in the suction strainers Debris that is identified will be removed and any strainer structure gaps will be assessed and repaired if necessary."

This inspection will be performed prior to startup from each refueling outage.

As a result of this response, the COLA will be revised as shown in the attached markup to FSAR Subsection 6C.5.1. This markup replaces, in its entirety, the Subsection 6C.5.1 markup that was provided in the supplemental response to RAI 06.02.02-20 (U7-C-STP-NRC-100060 dated March 15, 2010). Changes from COLA Rev. 3 are shown with gray shading. Only the last paragraph is added to the March 15, 2010 response.

6C.5.1 ECCS Pump Suction Strainer Sizing Design Basis

The ECCS suction strainer design to be used on STP 3&4, which is described in Appendix 6C.2 and its associated references, is the same as the design for the Reference Japanese ABWR (see References 6C-11, 6C-12 and 6C-13), and the STP 3&4 strainers will have at least the same area as the Reference Japanese ABWR strainers. Application of the Reference Japanese ABWR ECCS suction strainer design to STP 3&4 is conservative for the following reasons:

- The sizing of the Reference Japanese ABWR strainers is based on the methodology defined in the BWROG's Utility Resolution Guideline (URG) (Reference 6C-3).
- The Reference Japanese ABWR primary containment includes fibrous and calcium silicate thermal insulation, both of which are significant contributors to strainer head loss. For STP 3&4, the only type of thermal insulation allowed inside the primary containment is all stainless steel reflective metal insulation (RMI), which results in a much lower head loss across the ECCS suction strainers.

The application of the reference Japanese ABWR strainer head loss analysis to STP 3&4 is less conservative in one area. Section 6C.3 and Regulatory Guide 1.82, Rev. 3 state that the head loss calculations are to be performed at pump runout flow rate conditions. For the reference Japanese ABWR, these calculations were performed at design flow rate conditions. Because pump runout flow rate is greater than design flow rate and strainer head loss is proportional to flow rate, a higher suction strainer head loss is calculated at runout flow rate. However this higher head loss is more than compensated by other changes made by STP 3&4 compared with the reference Japanese ABWR, including the removal of fibrous and calcium silicate insulation materials from the containment. Consequently, the use of the reference Japanese ABWR for the licensing basis for STP 3&4 is conservative. This evaluation is documented in Reference 6C-13.

The expected cleanliness of the ABWR primary containment is supported by operating experience from one of the oldest Japanese ABWRs. Specifically, an inspection at this plant recovered items from the suppression pool, including tape fragments, plastic sheet fragments, and short segments of rope. None of these types of items were reported in the drywell as a result of that inspection, and no such items were reported in either the

drywell or suppression pool during the previous inspection 2 years earlier. To account for the potential that there might be a few similar items inadvertently left in the primary containment during the life of the plant, it is assumed that 2 filter pockets on each ECCS strainer are completely blocked by miscellaneous latent debris.