

**Comanche Peak Nuclear Power Plant, Units 3 & 4
COL Application
Part 2, FSAR**

CHAPTER 9
AUXILIARY SYSTEMS

TABLE OF CONTENTS

<u>Section</u>	<u>Title</u>	<u>Page</u>
9.0	AUXILIARY SYSTEMS.....	9.1-1
9.1	FUEL STORAGE AND HANDLING.....	9.1-1
9.1.2.1	Design Bases.....	9.1-1
9.1.5.3	Safety Evaluation.....	9.1-1
9.1.6	Combined License Information.....	9.1-1
9.2	WATER SYSTEMS.....	9.2-1
9.2.1.2.1	General Description.....	9.2-1
9.2.1.2.2	Component Description.....	9.2-2
9.2.1.2.2.1	ESWPs.....	9.2-2
9.2.1.3	Safety Evaluation.....	9.2-2
9.2.1.5.4	ESWP Motor Essential Service Water Flow.....	9.2-3
9.2.2.2.2	System Operations.....	9.2-4
9.2.4.1	Design Bases.....	9.2-4
9.2.4.2.1	General Description.....	9.2-5
9.2.4.2.2.1	Potable Water Storage Tank.....	9.2-5
9.2.4.2.2.2	Potable Water Pumps.....	9.2-5
9.2.4.2.2.3	Jockey Pump.....	9.2-6
9.2.4.2.3	System Operation.....	9.2-6
9.2.4.4	Inspection and Testing Requirements.....	9.2-6
9.2.4.5	Instrumentation Requirements.....	9.2-7
9.2.5.1	Design Bases.....	9.2-7
9.2.5.2	System Description.....	9.2-7
9.2.5.2.1	General Description.....	9.2-8
9.2.5.2.2	System Operation.....	9.2-8
9.2.5.2.3	System Performance.....	9.2-9
9.2.5.3	Safety Evaluation.....	9.2-10
9.2.5.4	Inspection and Testing Requirements.....	9.2-11
9.2.5.5	Instrumentation Requirements.....	9.2-12
9.2.7.2.1	Essential Chilled Water System.....	9.2-12
9.2.10	Combined License Information.....	9.2-12
9.3	PROCESS AUXILIARIES.....	9.3-1
9.3.1.2.1.3	Compressed Gas System.....	9.3-1
9.3.1.2.2.3	Compressed Gas System.....	9.3-2
9.3.6	Combined License Information.....	9.3-2

**Comanche Peak Nuclear Power Plant, Units 3 & 4
COL Application
Part 2, FSAR**

TABLE OF CONTENTS (Continued)

<u>Section</u>	<u>Title</u>	<u>Page</u>
9.4	AIR CONDITIONING, HEATING, COOLING, AND VENTILATION SYSTEMS	9.4-1
9.4.1.2	System Description.....	9.4-1
9.4.3.2.1	Auxiliary Building HVAC System.....	9.4-1
9.4.3.2.2	Non-Class 1E Electrical Room HVAC System.....	9.4-1
9.4.3.2.3	Main Steam/Feedwater Piping Area HVAC System	9.4-1
9.4.3.2.4	Technical Support Center HVAC System	9.4-2
9.4.5	Engineered Safety Feature Ventilation System	9.4-2
9.4.5.1.1.6	UHS ESW Pump House Ventilation System.....	9.4-2
9.4.5.2.2	Class 1E Electrical Room HVAC System	9.4-2
9.4.5.2.3	Safeguard Component Area HVAC System	9.4-3
9.4.5.2.4	Emergency Feedwater Pump Area HVAC System.....	9.4-3
9.4.5.2.5	Safety Related Component Area HVAC System	9.4-3
9.4.5.2.6	UHS ESW Pump House Ventilation System.....	9.4-3
9.4.5.3.6	UHS ESW Pump House Ventilation System.....	9.4-4
9.4.5.4.6	UHS ESW Pump House Ventilation System.....	9.4-4
9.4.5.5.6	UHS ESW Pump House Ventilation System.....	9.4-5
9.4.6.2.4.1	Containment Low Volume Purge System	9.4-5
9.4.6.2.4.2	Containment High Volume Purge System	9.4-5
9.4.7	Combined License Information	9.4-5
9.5	OTHER AUXILIARY SYSTEMS	9.5-1
9.5.1	Fire Protection Program.....	9.5-1
9.5.1.2	System Description.....	9.5-1
9.5.1.2.1	Facility Features for Fire Protection	9.5-1
9.5.1.2.2	Fire Protection Water Supply System	9.5-1
9.5.1.2.3	Fire Water Supply Piping, Yard Piping, and Yard Hydrants.....	9.5-2
9.5.1.2.4	Manual Suppression Means	9.5-2
9.5.1.3	Safety Evaluation.....	9.5-3
9.5.1.6	Fire Protection Program.....	9.5-3
9.5.1.6.1	Organization	9.5-4
9.5.1.6.1.1	Plant Manager	9.5-4
9.5.1.6.1.2	Director, Maintenance.....	9.5-4
9.5.1.6.1.3	Maintenance Team Manager	9.5-4
9.5.1.6.1.4	Manager, Technical Support.....	9.5-4
9.5.1.6.1.5	Nuclear Training Manager	9.5-5
9.5.1.6.1.6	CPNPP Fire Brigade.....	9.5-5
9.5.1.6.1.7	Offsite Fire Departments and Mutual Aid.....	9.5-6
9.5.1.6.1.8	Fire Brigade Equipment	9.5-7
9.5.1.6.1.9	Fire Watch Personnel	9.5-8
9.5.1.6.2	Fire Protection Training.....	9.5-8
9.5.1.6.2.1.1	Fire Brigade Classroom Instruction.....	9.5-8
9.5.1.6.2.1.2	Fire Brigade Practical Fire Fighting Training.....	9.5-9

**Comanche Peak Nuclear Power Plant, Units 3 & 4
COL Application
Part 2, FSAR**

TABLE OF CONTENTS (Continued)

<u>Section</u>	<u>Title</u>	<u>Page</u>
9.5.1.6.2.1.3	Fire Drills	9.5-9
9.5.1.6.2.1.4	Fire Watch Training	9.5-10
9.5.1.6.2.1.5	Fire Protection Training Records	9.5-10
9.5.1.6.3	Qualifications of Fire Protection Personnel	9.5-10
9.5.1.6.4	Fire Protection Procedures	9.5-11
9.5.1.6.4.1	Fire Fighting Procedures	9.5-12
9.5.1.6.4.2	Administrative Procedures and Controls	9.5-12
9.5.1.6.4.2.1	Design Control Procedures	9.5-12
9.5.1.6.4.2.2	Safe Shutdown Procedures	9.5-14
9.5.1.6.4.2.3	Low Power and Non-Power Procedures	9.5-14
9.5.1.6.4.2.4	Control of Combustibles	9.5-14
9.5.1.6.4.2.5	Control of Ignition Sources	9.5-15
9.5.1.6.4.2.6	Fire Protection Rounds	9.5-16
9.5.1.6.4.2.7	Fire Protection Preventative Maintenance	9.5-16
9.5.1.6.4.2.8	Fire Protection System Maintenance and Impairments	9.5-17
9.5.1.6.5	Fire Protection Quality Assurance Program	9.5-17
9.5.2	Communication Systems	9.5-17
9.5.2.2.2	Private Automatic Branch Telephone Exchange (PABX)	9.5-17
9.5.2.2.2.2	Emergency Telephones	9.5-18
9.5.2.2.5.1	General	9.5-18
9.5.2.2.5.2	Emergency Communications	9.5-18
9.5.2.3	Safety Evaluation	9.5-20
9.5.4.3	Safety Evaluation	9.5-20
9.5.9	Combined License Information	9.5-21
9.5.10	References	9.5-22

APPENDIX

APPENDIX 9A FIRE HAZARD ANALYSIS

**Comanche Peak Nuclear Power Plant, Units 3 & 4
COL Application
Part 2, FSAR**

LIST OF TABLES

<u>Number</u>	<u>Title</u>
9.2.1-1R	Essential Service Water System Component Design Data
9.2.4-1R	Potable and Sanitary Water System Component Data
9.2.5-201	Ultimate Heat Sink System Design Data
9.2.5-202	Ultimate Heat Sink System Failure Modes and Effects Analysis
9.4-201	Equipment Design Data
9.4-202	UHS ESW Pump House Ventilation System Equipment Design Data
9.5.1-1R	CPNPP Units 3 & 4 Fire Protection Program Conformance with RG 1.189
9.5.1-2R	CPNPP Units 3 & 4 Fire Protection Program Conformance with NFPA 804

**Comanche Peak Nuclear Power Plant, Units 3 & 4
COL Application
Part 2, FSAR**

LIST OF FIGURES

<u>Number</u>	<u>Title</u>
9.2.1-1R	Essential Service Water System Piping and Instrumentation Diagram
9.2.4-1R	Potable and Sanitary Water System Flow Diagram
9.2.5-201	Ultimate Heat Sink System Piping and Instrumentation Diagram
9.3.1-201	Hydrogen and Nitrogen Gas Supply Configuration
9.4-201	UHS ESW Pump House Ventilation System Flow Diagram
9.5.1-201	Fire Protection Water Supply System
9.5.1-202	CPNPP Units 3 & 4 Fire Main System

**Comanche Peak Nuclear Power Plant, Units 3 & 4
COL Application
Part 2, FSAR**

ACRONYMS AND ABBREVIATIONS

APWR	Advanced Pressure Water Reactor
ASME	American Society of Mechanical Engineers
CCW	component cooling water
CFR	Code of Federal Regulations
COL	Combined License
CPNPP	Comanche Peak Nuclear Power Plant
DBA	design-basis accident
DCD	Design Control Document
ESF	engineered safety features
ESW	essential service water
ESWP	essential service water pump
ESWS	essential service water system
FHA	fire hazard analysis
FPP	fire protection program
FPS	fire protection system
FSS	fire protection water supply system
GDC	General Design Criteria
HVAC	heating, ventilation, and air conditioning
HX	heat exchanger
LOCA	loss-of-coolant accident
LOOP	loss of offsite power
MCR	main control room
NFPA	National Fire Protection Association
NPSH	net positive suction head
P&ID	pipng and instrumentation diagram
PSWS	potable and sanitary water system
QA	quality assurance
QAP	quality assurance program
R/B	reactor building
RG	Regulatory Guide
SG	steam generator
SRP	Standard Review Plan
SSC	structure, system, and component
SSE	safe-shutdown earthquake
T/B	turbine building
UHS	ultimate heat sink
US	United States
VCT	volume control tank

**Comanche Peak Nuclear Power Plant, Units 3 & 4
COL Application
Part 2, FSAR**

9.0 AUXILIARY SYSTEMS

9.1 FUEL STORAGE AND HANDLING

This section of the referenced design control document (DCD) is incorporated by reference with the following departures and/or supplements.

9.1.2.1 Design Bases

Replace the last sentence of the last paragraph in **DCD Subsection 9.1.2.1** with the following.

CP COL 9.1(9) A procedure that will instruct the operator to perform formal inspection of the integrity of the spent fuel racks will be established prior to first fuel load.

9.1.5.3 Safety Evaluation

Replace the last paragraph in **DCD Subsection 9.1.5.3** with the following.

CP COL 9.1(6) To assure proper handling of heavy loads during the plant life, a Heavy Load Handling Program, including associated procedural and administrative controls, will be established prior to first fuel load. The program will satisfy commitments made in Subsection 9.1.5 of the DCD, and meet the guidance of ANSI/ASME B30.2, ANSI/ASME B30.9, ANSI N14.6, ASME NOG-1, CMMA Specification 70-2000, NUREG-0554, NUREG-0612, and NUREG-0800, Section 9.1.5. The Heavy Load Handling Program will include consideration of temporary cranes and hoists. The Heavy Load Handling Program will adopt a defense-in-depth strategy to enhance safety when handling heavy loads. For instance, the program will restrict lift heights to practical minimums and limit lifting activities as much as practical to plant modes in which load drops have a small potential for adverse consequences, particularly when critical loads are being handled. Further, prior to the lifting of heavy loads after initial fuel loading, the program will institute additional reviews to assure that potential drops of these loads due to inadvertent operations or equipment malfunctions, separately or in combination, will not jeopardize safe shutdown functions, cause a significant release of radioactivity, a criticality accident, or inability to cool fuel within the reactor vessel or spent fuel pit.

9.1.6 Combined License Information

Replace the content of **DCD Subsection 9.1.6** with the following.

CP COL 9.1(1) **9.1(1)** Deleted from the DCD.

**Comanche Peak Nuclear Power Plant, Units 3 & 4
COL Application
Part 2, FSAR**

9.1(2) Deleted from the DCD. |

9.1(3) Deleted from the DCD.

9.1(4) Deleted from the DCD.

9.1(5) Deleted from the DCD.

9.1(6) The establishment of a Heavy Load Handling Program |

This COL item is addressed in Subsection 9.1.5. |

9.1(7) Deleted from the DCD.

9.1(8) Deleted from the DCD.

CP COL 9.1(9) **9.1(9)** The establishment of an inspection procedure of spent fuel rack integrity |

This COL item is addressed in Subsection 9.1.2. |

Comanche Peak Nuclear Power Plant, Units 3 & 4
COL Application
Part 2, FSAR

9.2 WATER SYSTEMS

This section of the referenced DCD is incorporated by reference with the following departures and/or supplements.

9.2.1.2.1 General Description

CP COL 9.2(7) Replace the first sentence of the first paragraph in **DCD Subsection 9.2.1.2.1** with the following.

Figure 9.2.1-1R shows the piping and instrumentation diagrams (P&IDs) of the essential service water system (ESWS).

CP COL 9.2(25) Replace the eighth paragraph in **DCD 9.2.1.2.1** with the following:

Proper filling and venting procedures are followed to minimize the occurrence of water hammer and mitigate its effects. These are included in the Operating and Maintenance Procedures mentioned in Subsection 13.5.2.1

CP COL 9.2(8) Replace the eleventh paragraph in **DCD Subsection 9.2.1.2.1** with the following.

Chemicals are added to the basin to control corrosion, scaling, and biological growth. The water chemistry is managed through a Chemistry Control Program such as following a standard Langelier Saturation Index. The chemical injection system is described in Subsection 10.4.5.

Blowdown is used to maintain acceptable water chemistry composition. This is accomplished by tapping each essential service water pump (ESWP) discharge header. Additional description about blowdown is discussed in Subsection 9.2.5.

CP COL 9.2(7) Replace the twelfth paragraph in **DCD Subsection 9.2.1.2.1** with the following.

The non-safety-related portion of the ESWS begins at the discharge side of the strainer and CCW heat exchangers vent and drain valves. The positions of these valves are controlled by the Operating and Maintenance Procedures mentioned in Subsection 13.5.2.1 in order to maintain water-tight conditions and prevent inadvertent draining of the ESW.

CP COL 9.2(26) Replace the thirteenth paragraph in **DCD 9.2.1.2.1** with the following:

Maintenance and test procedures (see Operating and Maintenance Procedures in Subsection 13.5.2.1) are followed to monitor and flush debris accumulated in the system.

**Comanche Peak Nuclear Power Plant, Units 3 & 4
COL Application
Part 2, FSAR**

CP COL 9.5(2) Replace the last paragraph in **DCD Subsection 9.2.1.2.1** with the following.

Each of the essential service water (ESW) lines in the reactor building (R/B) and in the UHS ESW pump house is tapped to supply water to the fire protection water supply system (FSS), if required, after the safe-shutdown earthquake (SSE). Manually operated locked closed valves are provided in each of the tapped connections to draw water for the FSS.

9.2.1.2.2 Component Description

CP COL 9.2(6) Replace the sentence in **DCD Subsection 9.2.1.2.2** with the following.

Table 9.2.1-1R shows the design parameters of the major components in the system.

9.2.1.2.2.1 ESWPs

CP COL 9.2(6) Replace the second sentence of the third paragraph in **DCD Subsection 9.2.1.2.2.1** with the following.

Total dynamic head of the ESWP is 220 feet. Available net positive suction head (NPSH) with the lowest expected water level (after 30 days of accident mitigation) in the basin is approximately 40 feet.

9.2.1.3 Safety Evaluation

CP COL 9.2(1) Replace the twelfth paragraph in **DCD Subsection 9.2.1.3** with the following.

Design of the basin provides adequate submergence of the pumps to assure the NPSH for the pumps. The basin is divided into two levels. One is approximately 12 feet lower than the other, and directly above it is installed the ESWP. The ESWP is designed to operate with the lowest expected water level (after 30 days of accident mitigation). The basins have sufficient water inventory to assure adequate cooling and NPSH for 30 days without makeup. This is discussed further in Subsection 9.2.5.

Recovery procedures contained in the Operating and Maintenance Procedures (see Subsection 13.5.2.1) are implemented if the UHS approaches low water level.

CP COL 9.2(2) Replace the thirteenth paragraph in **DCD Subsection 9.2.1.3** with the following.

The lowest ambient temperature anticipated at the site does not result in the freezing of the ESW in the basin or the piping for the following reasons:

Comanche Peak Nuclear Power Plant, Units 3 & 4
COL Application
Part 2, FSAR

- The basins are located below grade and thus ground temperature maintains water from freezing.
- In the operating trains, water is continuously circulated which helps to prevent freezing. Ultimate heat sink (UHS) transfer pumps can be used to circulate water from the idle basins.
- UHS ESW pump house ventilation system maintains pre determined minimum temperature in the pump house areas. This is further described in Subsection 9.4.
- Any exposed essential piping that may be filled with water while the pump is not operating is heat traced.

For the thermal overpressure protection of the component cooling water heat exchanger ESW side, the valves located at the component cooling water heat exchanger ESW side inlet and outlet lines are administratively locked open valves. These locked open valves assure protection from the thermal overpressurization due to the erroneous valve operation coincident with the heat input from the component cooling water (CCW) side to ESW side.

CP COL 9.2(7) Replace the last two paragraphs in **DCD Subsection 9.2.1.3** with the following.

The ESWS serves as a backup source of water for the FSS in the R/B and in the ESWP house. This is in conformance with the requirement for an alternative fire protection water supply from a seismic category I water system in the event of a safe-shutdown earthquake, in accordance with RG 1.189. Two hose stations at approximately 150 gpm total take water from the ESWS for a maximum of two hours. Approximately 18,000 gallons is consumed by the FSS. This water volume has minimal impact on the UHS water inventory and does not jeopardize the 30 day capacity requirement. Administratively locked closed valves in each of the fire protection water supply taps assure that water inventory loss is controlled.

Specific design conditions such as maximum operating water temperature and required UHS water volume are described in detail in Subsections 9.2.5.2.3 and 9.2.5.3.

9.2.1.5.4 ESWP Motor Essential Service Water Flow

CP COL 9.2(7) Replace the content of **DCD Subsection 9.2.1.5.4** with the following.

Not applicable to Comanche Peak Nuclear Power Plant (CPNPP) Units 3 and 4.

**Comanche Peak Nuclear Power Plant, Units 3 & 4
COL Application
Part 2, FSAR**

9.2.2.2.2 System Operations

STD COL 9.2(27) Replace the last paragraph in **DCD Subsection 9.2.2.2.2** with the following.

The operating and maintenance procedures regarding water hammer are included in system operating procedures in Section 13.5.2.1. A milestone schedule for implementation of the procedures is also included in Subsection 13.5.2.1.

9.2.4.1 Design Bases

CP COL 9.2(10) Replace the first and second bullet in **DCD Subsection 9.2.4.1** with the following.
CP COL 9.2(11)

- The potable water system for CPNPP is designed to receive water from Somervell County Water District. The potable and sanitary water system pipes are fitted with backflow preventer to avoid chemical contamination. They are also physically separated from any radioactive sources, to prevent contamination. This assures that the water remains fit for human consumption and conforms to the requirements of GDC 60 (Reference 9.2.11-1).
 - The receipt of potable water from Somervell County Water District conforms to the requirements of the Environmental Protection Agency "National Primary Drinking Water Standards," 40 CFR 141 (Reference 9.2.11-4). All state and local environmental protection standards are applied and followed, as these may be more stringent than federal requirements.
-

CP COL 9.2(9) Replace the fourth bullet in **DCD Subsection 9.2.4.1** with the following.
CP COL 9.2(15)

- The supply capacity of potable water is 50 gpm (approximately 70,000 gpd), sufficient to provide a quantity of potable water based on 20 gpd for approximately 3500 persons expected to be at the station during a 24-hour period of power generation or outages. No onsite potable water storage tank is required.
-

CP COL 9.2(12) Replace the eighth bullet in **DCD Subsection 9.2.4.1** with the following.
CP COL 9.2(17)

- Sanitary drainage from all CPNPP Units 3 and 4 buildings is routed to a single on-site sanitary sump lift station via an underground sanitary sewer line. The sanitary wastewater is pumped by grinder pump to a new sanitary wastewater treatment plant for purification.

**Comanche Peak Nuclear Power Plant, Units 3 & 4
COL Application
Part 2, FSAR**

CP COL 9.2(12) Add the following bullet after the last bullet in **DCD Subsection 9.2.4.1**.

- The sanitary waste discharge system is designed to produce a wastewater effluent quality in compliance with federal, state, and local regulations and permits.
-

9.2.4.2.1 General Description

CP COL 9.2(11) Replace the content of **DCD Subsection 9.2.4.2.1** with the following.

CP COL 9.2(12)

CP COL 9.2(14)

The potable and sanitary water system (PSWS) flow diagram is shown in **Figure 9.2.4-1R**. Major component data for the PSWS are provided in **Table 9.2.4-1R**.

The source of potable water is from Somervell County Water District and provides an uninterruptible supply of 50 gpm directly to the end users. The potable water system consists of a distribution loop around the power block, local hot water heaters, and necessary interconnecting piping and valves. The water supply meets and/or exceeds the pressure, capacity, and quality requirements. No additional onsite water treatment is required.

The sanitary drainage system collects sanitary wastes from potable and non-potable water usage, from various plant areas such as restrooms and locker rooms. The waste is then drained to the 100,000-gpd sanitary wastewater treatment plant and 15 cu. ft. sludge dewatering filter press unit. The effluent is processed for disinfection and odor reduction and discharged to the Squaw Creek Reservoir. The sewage sludge is transferred to a truck for off-site landfill disposal. The sanitary drainage system does not serve any facilities in the radiologically controlled areas.

9.2.4.2.2.1 Potable Water Storage Tank

CP COL 9.2(9) Replace **DCD Subsection 9.2.4.2.2.1** with the following.

CP COL 9.2(15)

Not applicable to CPNPP Units 3 and 4.

9.2.4.2.2.2 Potable Water Pumps

CP COL 9.2(9) Replace **DCD Subsection 9.2.4.2.2.2** with the following.

CP COL 9.2(15)

Not applicable to CPNPP Units 3 and 4.

**Comanche Peak Nuclear Power Plant, Units 3 & 4
COL Application
Part 2, FSAR**

9.2.4.2.2.3 Jockey Pump

CP COL 9.2(9) Replace **DCD Subsection 9.2.4.2.2.3** with the following.
CP COL 9.2(15)

Not applicable to CPNPP Units 3 and 4.

9.2.4.2.3 System Operation

CP COL 9.2(13) Replace the first, second and third paragraphs in **DCD Subsection 9.2.4.2.3** with the following.

Potable water from Somervell County Water District is supplied directly to the end users onsite. Water pressure is controlled so that it is comparable to that of an off-site water district customer. Each distribution line is equipped with a pressure control valve and required instrumentation to regulate the flow of potable water based on demand. A pressure transmitter is provided downstream of the branched supply lines to control valve operation.

CP COL 9.2(17) Add the following text after the last paragraph in **DCD Subsection 9.2.4.2.3**

The sanitary wastewater generated by CPNPP Units 3 and 4 is drained to a single collection sump lift station equipped with a grinder pump. This grinder pump discharges the wastewater to an underground sewer line. The sewer line transfers the wastewater to a new sump lift station located next to the sanitary wastewater treatment system. The sanitary wastewater treatment system has a hydraulic flow that processes the wastes and separates the effluent from the solids. The clear effluent is passed through a ultraviolet disinfection system to produce a treated effluent that meets the permitted discharge limit requirement and discharged to Squaw Creek Reservoir.

Excessive sludge from the sanitary wastewater treatment system is further transferred to the sludge-conditioning tank and the filter press of the Filter Press Unit for sludge dewatering. The dry sewage sludge is discharged and collected on mobile carts below the filter press is then transferred to a dumpster for disposal to class 1 landfill.

9.2.4.4 Inspection and Testing Requirements

CP COL 9.2(13) Replace the content of **DCD Subsection 9.2.4.4** with the following.

- The potable water system and the sanitary drainage system is tested hydrostatically for leak-tightness and system inspection is performed in accordance with applicable uniform plumbing code requirement. Periodic

**Comanche Peak Nuclear Power Plant, Units 3 & 4
COL Application
Part 2, FSAR**

testing for microbiological growth including bacteria in the sanitary waste is conducted before discharge.

9.2.4.5 Instrumentation Requirements

CP COL 9.2(13) Replace the second through seventh bullets in **DCD Subsection 9.2.4.5** with the following.

- A pressure controller located on each branched off discharge of the potable water system automatically adjusts the valve position based on usage and capacity.
 - The instruments associated with the sanitary wastewater treatment system are a part of the treatment plant. Sufficient instrumentation for operation is provided with the treatment plant.
-

9.2.5.1 Design Bases

CP COL 9.2(18) Replace the eighth bullet of the second paragraph in **DCD Subsection 9.2.5.1** with the following.

- The UHS is designed in accordance with Regulatory Guide 1.27 with inventory sufficient to provide cooling for at least 30 days following an accident, with no makeup water.
-

9.2.5.2 System Description

CP COL 9.2(3) Replace the last six paragraphs in **DCD Subsection 9.2.5.2** with the following.

CP COL 9.2(4)

CP COL 9.2(5)

CP COL 9.2(18)

CP COL 9.2(19)

Mechanical draft cooling towers with basins, based on site condition and meteorological data, are used for CPNPP Units 3 and 4.

CP COL 9.2(20)

CP COL 9.2(21)

A detailed description and drawing of the UHS are provided in Subsection 9.2.5.2.1, **Figure 9.2.5-201**, and **Table 9.2.5-201**.

The source of makeup water to the UHS inventory and blowdown discharge location are discussed below.

Comanche Peak Nuclear Power Plant, Units 3 & 4
COL Application
Part 2, FSAR

9.2.5.2.1 General Description

Each unit is provided with its own independent UHS, with no sharing between the two units. The UHS for each unit consists of four 50 percent capacity mechanical draft cooling towers, one for each ESWS train, and four 33 one-third percent capacity basins to satisfy the thirty day cooling water supply criteria of RG 1.27.

Each cooling tower consists of two cells with fans and motors, drift eliminators, film fills, risers, and water distribution system all enclosed and supported by a seismic category I reinforced concrete structure. Each basin includes an ESWP intake structure that contains one 50 percent capacity ESWP and one 100 percent capacity UHS transfer pump, and associated piping and components. Tornado missile protection for the cooling tower components, ESWPs and piping is provided by the UHS safety-related seismic category I structures and ESW pipe tunnel as discussed in Subsection 3.8.4. The UHS structural design, including pertinent dimensions, is also discussed in Subsection 3.8.4.

Each cooling tower consists of two cells, each with a motor driven fan driven with a right-angle gear reducer. The fan motors are powered from the Class 1E normal ac power system. On loss of offsite power (LOOP), the motors are automatically powered from their respective division emergency power source.

Inside dimensions of each basin are approximately 123 feet x 123 feet and 31 feet deep at normal water level. The cooling towers utilize the basins for structural foundation.

The UHS operates in conjunction with the ESWS. The ESWS is described in Subsection 9.2.1. P&IDs of the UHS are provided in [Figure 9.2.5-201](#). The UHS design and process parameters are provided in [Table 9.2.5-201](#). The normal makeup water to the UHS inventory is from Lake Granbury via the circulating water system described in Subsection 10.4.5. A control valve with instrumentation located in each makeup line maintains basin water level during normal operation. The blowdown water is discharged to Lake Granbury via the circulating water system.

The mechanical draft cooling towers are the UHS. Hence, no discharge structure is necessary.

9.2.5.2.2 System Operation

The ESWPs take suction from the basin as described in Subsection 9.2.1. The water flows through the CCW heat exchangers and essential chiller units and then is cooled by the cooling tower before being returned to the basin.

Heat rejection to the environment is effected by direct contact with the cooling tower forced airflow, which provides evaporative cooling of the ESW return flow. During normal operation, evaporation, drift and blowdown losses are replaced with the makeup from Lake Granbury. Water level controllers provided in each basin automatically open and close the makeup control valves. Low and high

Comanche Peak Nuclear Power Plant, Units 3 & 4
COL Application
Part 2, FSAR

water level annunciation in the main control room (MCR) indicates a malfunction of the makeup control valve or the blowdown control valve.

Adequate NPSH is maintained under all operating modes, including loss-of-coolant accident (LOCA) and LOOP, with one train out of service for maintenance, when the source of makeup water is assumed lost for a period of thirty days after the accident. During such conditions, the combined inventory of three basins provides a thirty-day cooling water supply assuming the worst combination of meteorological conditions and accident heat loads.

The UHS transfer pumps and the ESWPs located in each basin are powered by the different Class 1E buses, e.g., for basin A, the ESWP is powered from bus A, and the UHS transfer pump is powered from bus C or D, depending on manual breaker alignment.

The basins are concrete seismic category I structures and are located mostly below grade. Hence, a complete failure resulting in loss of water inventory is considered highly improbable.

Operation details of the ESWS, including chemical treatment, pump NPSH, and freeze protection operation, are provided in Subsection 9.2.1.

A portion of the basin water is discharged through the blowdown via the ESWS when the makeup water is available. The blowdown rate is determined using a conductivity cell located at ESW pump discharge and is based on the total dissolved solids in the water and the makeup water source. During design-basis accident (DBA) conditions or loss of makeup water, the blowdown is terminated.

9.2.5.2.3 System Performance

DCD Table 9.2.5-1 lists the UHS peak heat loads during accident conditions (i.e., LOCA) with two trains operation and four trains operation. Table 9.2.5-2 provides the heat loads for LOCA and safe shutdown conditions with loss of off-site power for two-train and four-train operations of the ESWS. The heat load per train during two-train operation is higher than the heat load per train during four-train operation. Therefore, the UHS is designed assuming two-train operation of the ESWS, which bounds four-train operation of the ESWS.

The UHS is designed with sufficient inventory to provide cooling for at least 30 days following an accident with no makeup water. The UHS must be capable of dissipating the design bases heat loads under the worst environmental conditions that minimize heat dissipation without exceeding the maximum ESW supply temperature of 95°F.

The wet bulb design temperature was selected to be 80°F based on 30 years (1977-2006) of climatological data obtained from National Climatic Data Center /National Oceanic & Atmospheric Administrator for Dallas/ Fort Worth International Airport Station in accordance with RG 1.27. The worst 30 day period

Comanche Peak Nuclear Power Plant, Units 3 & 4
COL Application
Part 2, FSAR

based on the above climatological data was between June 1, 1998 and June 30, 1998, with an average wet bulb temperature of 78.0°F. A 2°F margin was added to the maximum average wet bulb temperature for conservatism.

The UHS is analyzed using the heat loads provided in Table 9.2.5-2 for LOCA and safe shutdown conditions with LOOP and a maximum ESW supply temperature of 95°F. Per Subsection 9.2.1.2, each ESWP is designed to provide 13,000gpm flow. Since cooling water flow is inversely proportional to the cooling tower temperature range, for conservatism, a lower ESW flow of 12,000 gpm to each cooling tower is used in the analysis.

The required total water usage (due to cooling tower drift and evaporation) over the postulated 30 day period is determined as follows:

Total Evaporation (E) and Drift (D) rates were calculated using the ESW flow rate (GPM) of 12,000 gpm times the temperature rise (CR) and a conservative cooling tower factor of 0.0009, $E \text{ (total)} = \text{GPM} \times \text{CR} \times 0.0009$.

- a. The cooling tower factor of 0.0009 is considered conservative since it is based on standard cooling tower evaporation factor of 0.0008, and typical cooling tower drift rate of 0.0002 This is expressed as

$$\text{Total Evaporation (E)} = \text{GPM} \times \text{CR} \times 0.0008 + \text{GPM} \times 0.0002$$

- b. The ESW temperature rise (CR) was based on heat rate equation of H as

$$\text{Heat Rate (H)} = m \times \text{specific heat} \times \text{CR},$$

where, m = mass flow rate

- c. Accumulative evaporation (gallons/cooling tower) is calculated by multiplying the evaporation rate (gpm) and its corresponding time interval.
- d. The total water loss due to evaporation and drift for the 30 days period is calculated and is defined as the plant unit minimum required water capacity for the basin design in accordance with RG 1.27.

Based on the above analyses, the governing case for the maximum required 30 days cooling water capacity is two-train operation during LOCA condition, with a total required cooling water of approximately 8.54 million gallons. For the cooling tower design heat load the governing case is the safe shutdown conditions with LOOP for two-train operation, with a heat load of 196 million Btu/hr.

9.2.5.3 Safety Evaluation

CP COL 9.2(22) Replace the content of **DCD Subsection 9.2.5.3** with the following.

The results of the UHS capability and safety evaluation are discussed in detail in Subsection 9.2.5.2.3 and in this Subsection. The UHS is capable of rejecting the heat under limiting conditions as discussed in Subsection 9.2.5.2.3.

Comanche Peak Nuclear Power Plant, Units 3 & 4
COL Application
Part 2, FSAR

The failure modes and effects analysis for the UHS are included in Table 9.2.5-202 and demonstrate that the UHS satisfies the single failure criteria.

The basin is designed to withstand the effect of natural phenomena, such as earthquake, tornado, hurricanes, and floods taken individually, without loss of capability to perform its safety function.

The combined volume of water in the three basins is sufficient to provide at least 30 days required cooling capacity.

The total required 30 days cooling water capacity is approximately 8.54 million gallons, or approximately 2.85 million gallons per basin. Each basin dimension, not including any column or wall sections, is 120 feet x 120 feet with a water depth of 29 feet from the minimum maintained water level, the usable water volume available for each basin is approximately 3.12 million gallons. The water depth excludes one foot of unusable space from the basin floor, where sedimentation may accumulate.

During accident conditions, including LOCA and LOOP, makeup to the basin is presumed lost. During such conditions, the UHS transfer pump operates to permit the use of three of the four basin water volumes. The power supply for each transfer pump is from a different division than the ESWP and cooling tower in that basin. Therefore, loss of one electrical train does not compromise the ability to satisfy the short-term accident requirements.

A description and provision to prevent freezing of the ESWS and the UHS is provided in Subsection 9.2.1.

9.2.5.4 Inspection and Testing Requirements

CP COL 9.2(23) Replace the content of **DCD Subsection 9.2.5.4** with the following.

Inservice inspection of piping is performed in accordance with the requirements of ASME Section XI, and is included in Section 6.6.

Inservice testing of pumps and valves is performed to ensure operational readiness and is included in Subsection 3.9.6.

Periodic inspections and testing of the mechanical cooling tower components, including fan, motors, and reducing gears, are performed in accordance with cooling tower manufacturer's recommendation and as a part of the monitoring required in Generic Letter 89-13 to maintain acceptable system performance.

Manholes, handholes, inspection ports, ladder, and platforms are provided, as required, for periodic inspection of system components.

Comanche Peak Nuclear Power Plant, Units 3 & 4
COL Application
Part 2, FSAR

9.2.5.5 Instrumentation Requirements

CP COL 9.2(24) Replace the sentence in **DCD Subsection 9.2.5.5** with the following.

Water level in each of the basins is controlled by level instrumentation that opens or closes the automatic valves in the makeup lines.

Two level transmitters and associated signal processors are provided for each basin to indicate water level in the basin and annunciate in the MCR for both the high and low water levels in the basin.

A water level signal at six inches below the normal water level causes the makeup water control valve to open. A signal at normal water level then causes the makeup control valve to close. A low level alarm annunciates in the MCR whenever the water level falls one foot below the normal water level.

During accident condition, level indications from the operating basins are used to alert the MCR operator to start the UHS transfer pump to transfer water from the idle basin to the operating basins.

Blowdown rate is controlled manually. The blowdown control valves close automatically upon receipt of a low water level signal or emergency core cooling system actuation signal. The valve is designed to fail in the close position. Failure of the valve to close is indicated in the MCR.

The conductivity cells are provided at the ESW pump discharge line and conductivity are indicated in the MCR.

Temperature elements are provided in each basin and temperatures are indicated in the MCR.

Local flow rate and pressure indicators located in each UHS transfer pump discharge header are used for pump performance testing.

The cooling tower fan is equipped with vibration sensors that alarm in the control room in the event of high vibration.

9.2.7.2.1 Essential Chilled Water System

STD COL 9.2(27) Replace the last paragraph in **DCD Subsection 9.2.7.2.1** with the following.

The operating and maintenance procedures regarding water hammer are included in system operating procedures in Subsection 13.5.2.1. A milestone schedule for implementation of the procedures is also included in Subsection 13.5.2.1.

9.2.10 Combined License Information

Replace the content of **DCD Subsection 9.2.10** with the following.

Comanche Peak Nuclear Power Plant, Units 3 & 4
COL Application
Part 2, FSAR

CP COL9.2(1) **9.2(1)** *The evaluation of ESWP at the lowest probable water level of the UHS and the recovery procedures when UHS approaches low water level*

*This COL item is addressed in **Subsection 9.2.1.3**.*

CP COL 9.2(2) **9.2(2)** *The protection against adverse environmental, operating and accident condition that can occur such as freezing, thermal over pressurization*

*This COL item is addressed in **Subsection 9.2.1.3**.*

CP COL 9.2(3) **9.2(3)** *Source and location of the UHS*

*This COL item is addressed in **Subsection 9.2.5.2**.*

CP COL 9.2(4) **9.2(4)** *The location and design of the ESW intake structure*

*This COL item is addressed in **Subsection 9.2.5.2**.*

CP COL 9.2(5) **9.2(5)** *The location and the design of the discharge structure*

*This COL item is addressed in **Subsection 9.2.5.2**.*

CP COL 9.2(6) **9.2(6)** *The ESWP design details – required total dynamic head, NPSH available*

*This COL item is addressed in **Subsection 9.2.1.2.2, 9.2.1.2.2.1 and Table 9.2.1-1R**.*

CP COL 9.2(7) **9.2(7)** *The design of ESWS related with the site specific UHS*

*This COL item is addressed in **Subsections 9.2.1.2.1, 9.2.1.3, 9.2.1.5.4 and Figure 9.2.1-1R**.*

CP COL 9.2(8) **9.2(8)** *The ESW specific chemistry requirements*

*This COL item is addressed in **Subsection 9.2.1.2.1**.*

CP COL 9.2(9) **9.2(9)** *The storage capacity and usage of the potable water*

*This COL item is addressed in **Subsections 9.2.4.1, 9.2.4.2.2.1, 9.2.4.2.2.2 and 9.2.4.2.2.3**.*

CP COL 9.2(10) **9.2(10)** *State and Local Department of Health and Environmental Protection Standards*

*This COL item is addressed in **Subsection 9.2.4.1**.*

CP COL 9.2(11) **9.2(11)** *Source of potable water to the site and the necessary required treatment*

**Comanche Peak Nuclear Power Plant, Units 3 & 4
COL Application
Part 2, FSAR**

*This COL item is addressed in **Subsections 9.2.4.1, 9.2.4.2.1 and Figure 9.2.4-1R.***

CP COL 9.2(12) **9.2(12)** *Sanitary waste treatment*

*This COL item is addressed in **Subsections 9.2.4.1 and 9.2.4.2.1.***

CP COL 9.2(13) **9.2(13)** *Supply of water (city or on-site wells of another) and the system operation.*

*This COL item is addressed in **Subsections 9.2.4.2.3, 9.2.4.4 and 9.2.4.5.***

CP COL 9.2(14) **9.2(14)** *Potable and sanitary water system components data*

*This action is addressed in **Subsections 9.2.4.2.1 and Table 9.2.4-1R.***

CP COL 9.2(15) **9.2(15)** *Total number of people at the site, the usage capacity and sizing of the potable water tank and associated pumps.*

*This COL item is addressed in **Subsections 9.2.4.1, 9.2.4.2.2.1, 9.2.4.2.2.2 and 9.2.4.2.2.3.***

CP COL 9.2(16) **9.2(16)** *Values to the component based on calculations*

*This COL item is addressed in **Table 9.2.4-1R.***

CP COL 9.2(17) **9.2(17)** *Sanitary lift stations and the sizing the appropriate interfaces*

*This COL item is addressed in **Subsections 9.2.4.1 and 9.2.4.2.3.***

CP COL 9.2(18) **9.2(18)** *The type of the UHS based on specific site conditions and meteorological data*

*This COL item is addressed in **Subsections 9.2.5.1 and 9.2.5.2.***

CP COL 9.2(19) **9.2(19)** *The design of the electrical power supply to the UHS*

*This COL item is addressed in **Subsection 9.2.5.2.***

CP COL 9.2(20) **9.2(20)** *The description and the P&ID of the UHS*

*This COL item is addressed in **Subsections 9.2.5.2, Table 9.2.5-201 and Figure 9.2.5-201.***

CP COL 9.2(21) **9.2(21)** *The source of makeup water to the UHS and the blowdown discharge location*

*This COL item is addressed in **Subsections 9.2.5.2.***

**Comanche Peak Nuclear Power Plant, Units 3 & 4
COL Application
Part 2, FSAR**

CP COL 9.2(22) **9.2(22)** *The UHS capability and safety evaluation*

*This COL item is addressed in **Subsection 9.2.5.3** and **Table 9.2.5-202**.*

CP COL 9.2(23) **9.2(23)** *The test and inspection requirements of the UHS*

*This COL item is addressed in **Subsection 9.2.5.4**.*

CP COL 9.2(24) **9.2(24)** *The required alarms, instrumentation and controls of the UHS system*

*This COL item is addressed in **Subsection 9.2.5.5**.*

CP COL 9.2(25) **9.2(25)** *The operating and maintenance procedures to address water hammer issues*

*This COL item is addressed in **Subsections 9.2.1.2.1** and **13.5.2.1**.*

CP COL 9.2(26) **9.2(26)** *Maintenance and test procedures to monitor and flush out debris*

*This COL item is addressed in **Subsections 9.2.1.2.1** and **13.5.2.1**.*

STD COL 9.2(27) **9.2(27)** *Operating and maintenance procedures of water hammer prevention*

*This COL Item is addressed in **Subsection 9.2.2.2.2.6** and **9.2.7.2.1**.*

**Comanche Peak Nuclear Power Plant, Units 3 & 4
COL Application
Part 2, FSAR**

Table 9.2.1-1R

Essential Service Water System Component Design Data

CP COL 9.2(6)

Essential Service Water Pump	
Quantity	4
Type	Vertical, centrifugal, mixed flow
Design flow rate	13,000 gpm
Design Head	220 feet
Design pressure	150 psig
Design temperature	140 ° F
Materials	Stainless steel
Equipment Class	3
Essential Service Water Pump Outlet Strainer	
Quantity	8
Design flow rate	13,000 gpm
Design pressure	150 psig
Design temperature	140 ° F
Equipment Class	3
Component Cooling Water Heat Exchanger Inlet Strainer	
Quantity	4
Design flow rate	11,500 gpm
Design pressure	150 psig
Design temperature	140 ° F
Equipment Class	3
Essential Service Water Pump Discharge Valve	
Quantity	4
Design flow rate	13,000 gpm
Design pressure	150 psig
Design temperature	140 ° F
Equipment Class	3

**Comanche Peak Nuclear Power Plant, Units 3 & 4
COL Application
Part 2, FSAR**

CP COL 9.2(14)
CP COL 9.2(16)

Table 9.2.4-1R

Potable and Sanitary Water System Component Data

Grinder Pump

Quantity	1
Type	Submersible Type

**Comanche Peak Nuclear Power Plant, Units 3 & 4
COL Application
Part 2, FSAR**

CP COL 9.2(20)

Table 9.2.5-201

Ultimate Heat Sink System Design Data

UHS Cooling Tower and Basin

Physical Data

Type and Quantity	Wet, mechanical draft Four (4) – 50 percent cooling tower with basin Two (2) cells per cooling tower
Basin Size	Footprint Approx 123 feet x 123 feet (inside dimensions) Depth Approx 31 feet (at normal water level)
Usable Basin Water Volume	3.12 x 10 ⁶ gallon per basin (at minimum maintained water level)
Fan and Motor Quantity	One (1) each per cell
Fan driver	200 rated hp

Process Parameters

Design Cooling Water Flow Rate	13,000 (gpm per cooling tower)
Design Heat Load	1.96 x10 ⁸ (Btu/hr per cooling tower)
Cooling Water Temperature	Hot (Inlet) 128 °F Cold (Outlet) 95 F
Design wet bulb Temperature	80 °F

UHS Transfer Pump

Quantity	4
Type	Vertical, centrifugal
Design flow rate	800 gpm
Total Head	40 feet
Design pressure	100 psig
Design temperature	140 ° F
Materials	Stainless Steel
Equipment Class	3

Comanche Peak Nuclear Power Plant, Units 3 & 4
COL Application
Part 2, FSAR

CP COL 9.2(22)

Table 9.2.5-202 (Sheet 1 of 2)
Ultimate Heat Sink System Failure Modes and Effects Analysis

Description of Component	Safety Function	Plant Operating Mode	Failure Mode(s)	Method of		General Remarks
				Detection	Failure Effect on System Safety Function Capability	
UHS Cooling Tower Fan (UHS-OEQ-001A, B, C, D and UHS-OEQ-002A, B, C, D)	Circulates ambient air through cooling tower to cool ESW	All	Fails to start upon command	Fan status indication light in MCR	None, Remaining three 50 percent capacity cooling towers are available. Minimum two towers are required for safe shutdown.	One Train out due to maintenance does not affect safety function, because minimum of two cooling towers are required.
UHS Transfer Pump (UHS-OPP-001A, B, C, D)	Transfers 33-1/3 percent of required 30 days cooling water from inoperable basin to two (2) operating basins	Accident, Safe shutdown, Cooldown – loss of offsite power	Fails to start upon command	Pump status light indication in MCR	None, Even if the single failure is assumed to the transfer pump, the cooling tower located at the same basin as the inoperable transfer pump can use own basin water. It is not necessary to transfer this basin water to other basin.	
UHS Transfer Pump Discharge Valve (MOV-503A, B, C, D), fail as is, motor operated valve	Opens to provide flow path	Accident, Safe shutdown, Cooldown – loss of offsite power	Fails to open upon command	Position indication in MCR	None, Even if the single failure is assumed to the valve, the cooling tower located at the same basin as the inoperable valve can use own basin water.	It is not necessary to transfer this basin water to other basin.

**Comanche Peak Nuclear Power Plant, Units 3 & 4
COL Application
Part 2, FSAR**

Table 9.2.5-202 (Sheet 2 of 2)

Ultimate Heat Sink System Failure Modes and Effects Analysis

Description of Component	Safety Function	Plant Operating Mode	Failure Mode(s)	Method of failure Detection	Failure Effect on System Safety Function Capability	General Remarks
UHS Transfer Line Basin Inlet valve (MOV-506A, B, C, D), fail as is, motor operated valve	Opens to provide flow path	Accident, Safe shutdown, Cooldown – loss of offsite power	Fails to open upon command	Position indication in MCR	None, This failure effect is bounded by the failure effect of UHS Cooling Tower Fan.	
UHS Basin Blowdown Control Valve (EWS-HCV-2000, 2001, 2002, 2003), fail close air operated valve	Closes to isolate blowdown	All	Fails to close upon command	Position indication in MCR	None, Blowdown can be isolated by closing manual valves (VLV-541A,B,C,D, VLV-543A,B,C,D)	Effect of uncontrolled blowdown for 30 minutes on basin inventory is insignificant.

**Comanche Peak Nuclear Power Plant, Units 3 & 4
COL Application
Part 2, FSAR**

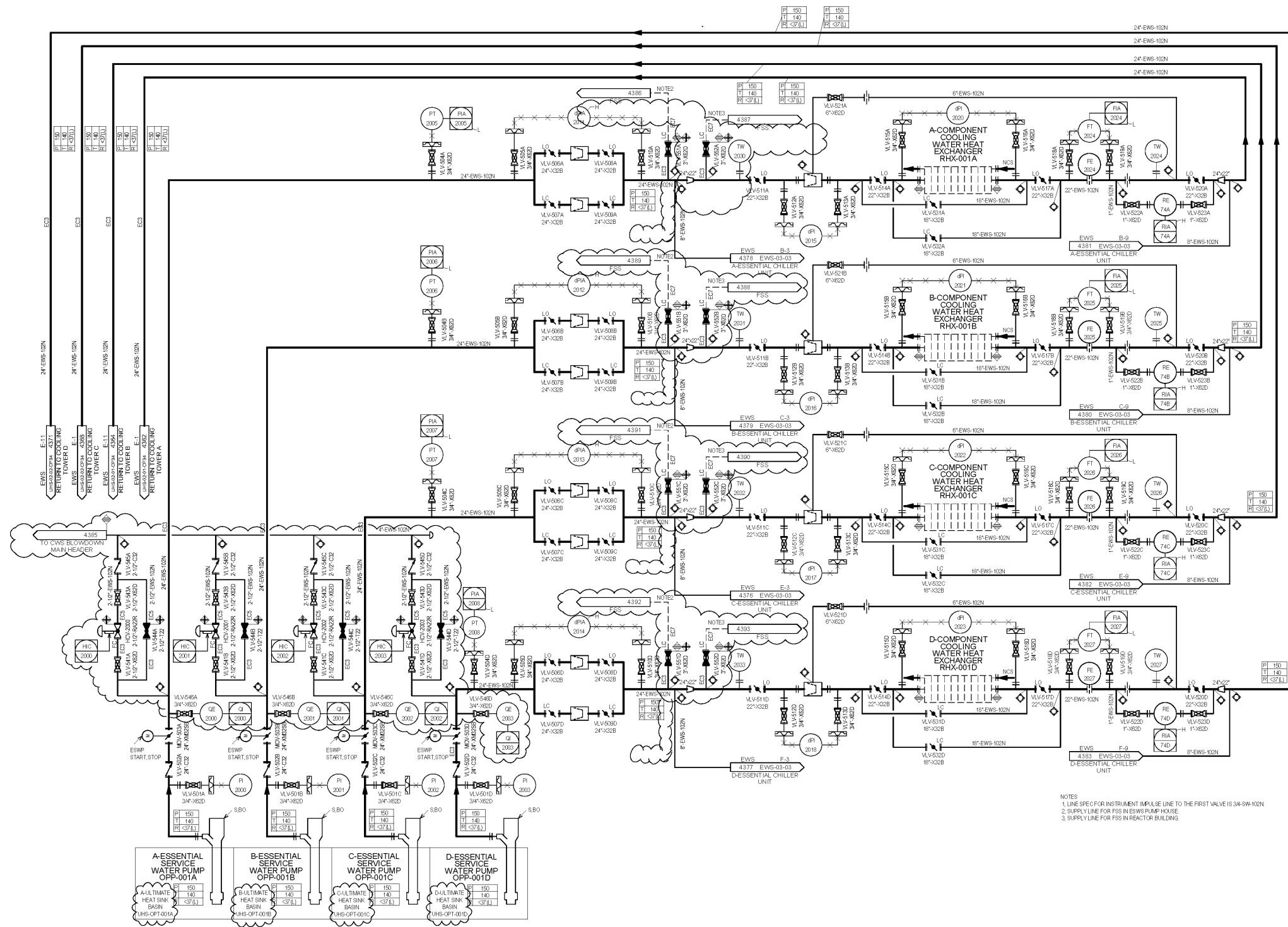

NOTES
 1. LINE SPEC FOR INSTRUMENT IMPULSE LINE TO THE FIRST VALVE IS 3/4" SW-102N
 2. SUPPLY LINE FOR FSS IN ESWP HOUSE
 3. SUPPLY LINE FOR FSS IN REACTOR BUILDING

Figure 9.2.1-1R Essential Service Water System Piping and Instrumentation Diagram (Sheet 1 of 2)

**Comanche Peak Nuclear Power Plant, Units 3 & 4
COL Application
Part 2, FSAR**

**Comanche Peak Nuclear Power Plant, Units 3 & 4
COL Application
Part 2, FSAR**

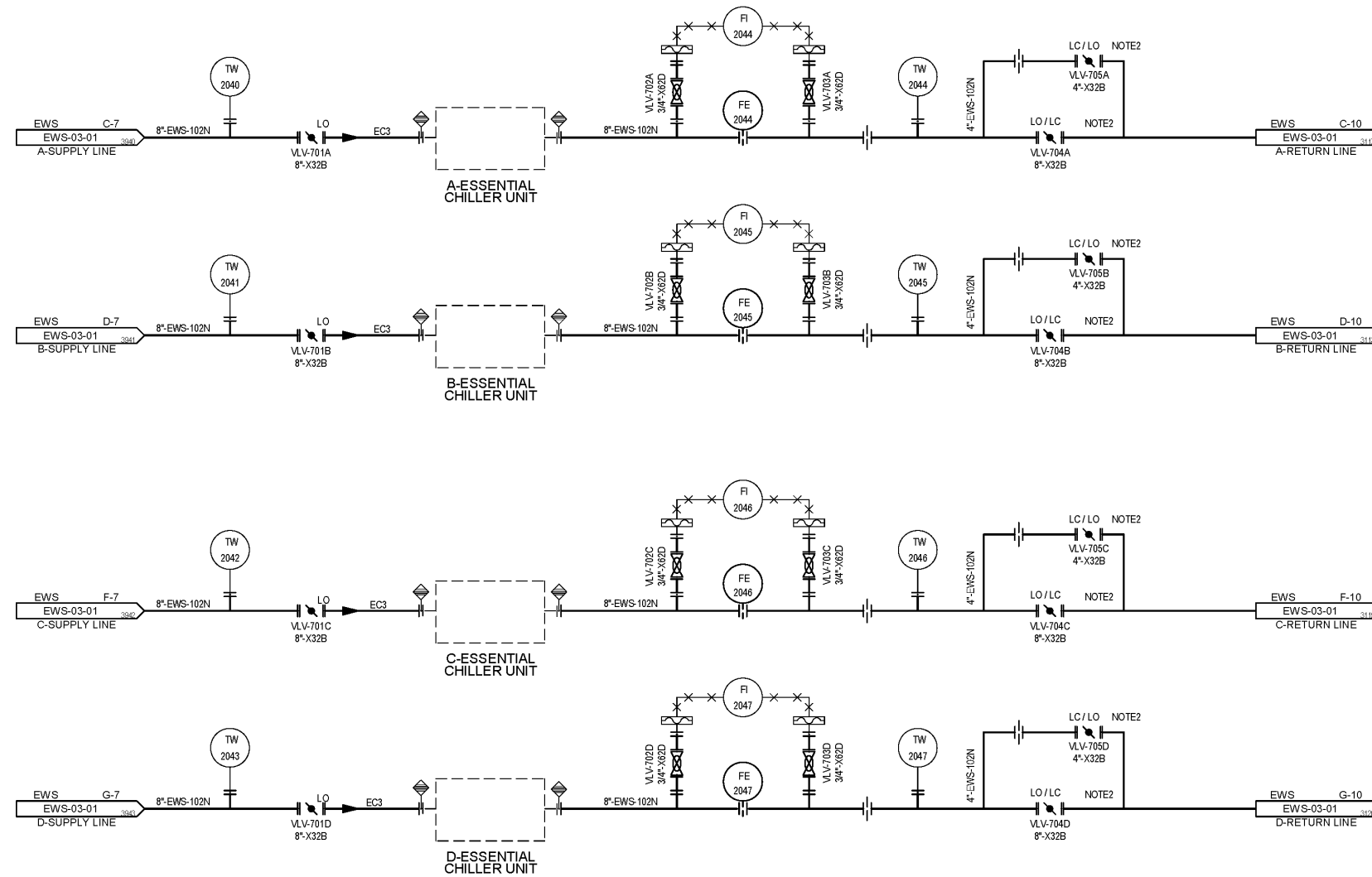

NOTES
 1. LINE SPEC FOR INSTRUMENT IMPULSE LINE TO THE FIRST VALVE IS 3/4" EWS-102N.
 2. OPENING THE VALVE AT THE MAIN LINE REQUIRES CLOSING THE VALVE AT THE BYPASS LINE AND VICE VERSA.

Figure 9.2.1-1R Essential Service Water System Piping and Instrumentation Diagram (Sheet 2 of 2)

**Comanche Peak Nuclear Power Plant, Units 3 & 4
COL Application
Part 2, FSAR**

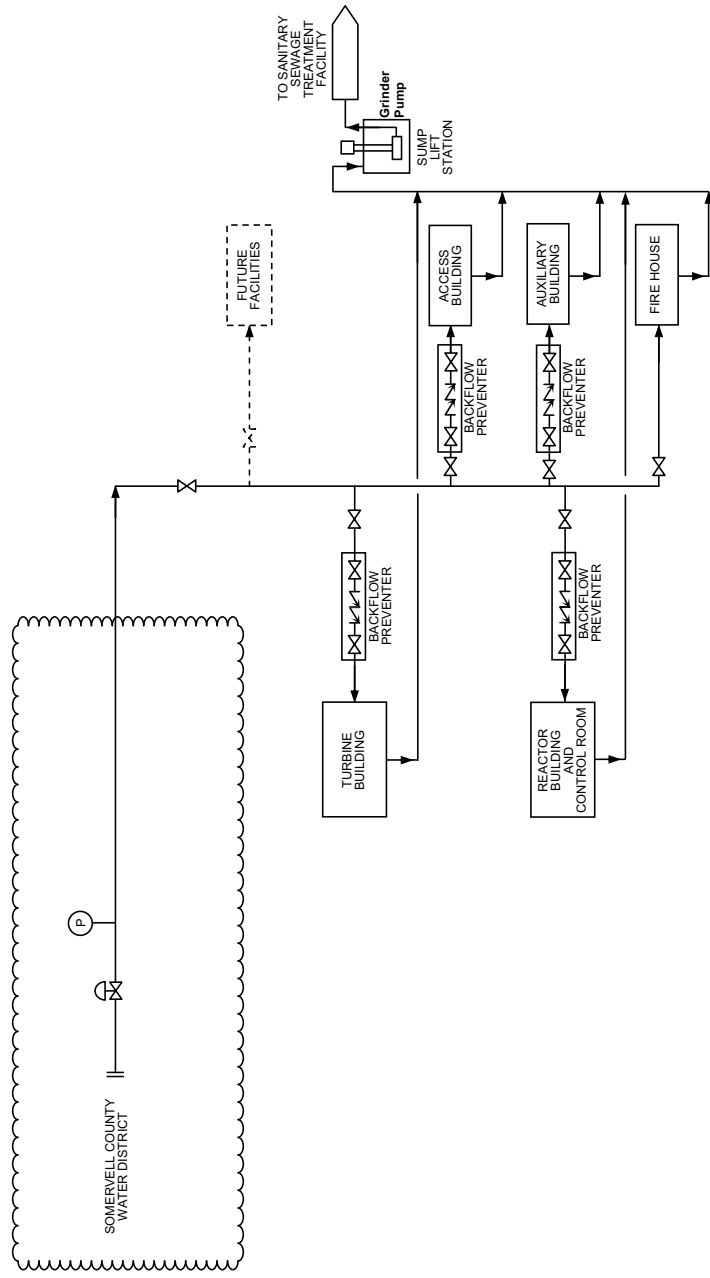
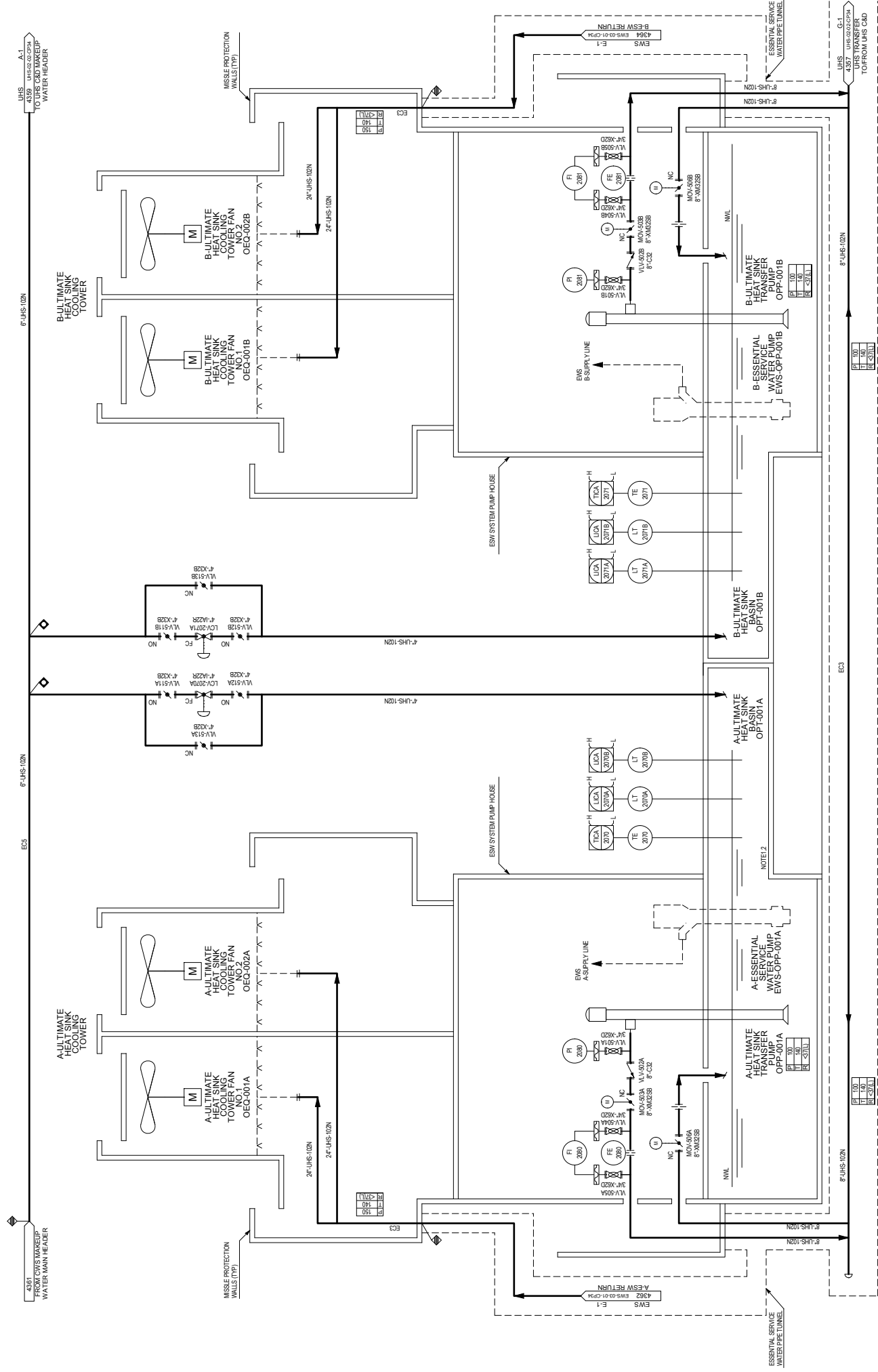

Figure 9.2.4-1R Potable and Sanitary Water System Flow Diagram

CP COL 9.2(11)

Comanche Peak Nuclear Power Plant, Units 3 & 4
COL Application
Part 2, FSAR



NOTES:
1. PUMP AND TRANSFER PUMP COATED IN THE SAME COOLING TOWER PUMP HOUSE ARE PHYSICALLY SEPARATED BY FIRE INTERBARRIER AND NOT TO BECOME SIMULTANEOUSLY INOPERABLE BY THE DISTURBANCE SUCH AS FIRE.
2. THE TRANSFER PUMP IS TO BE PROVIDED WITH A BACKFLOW PREVENTER ON A DRAIN LINE WHICH IS LARGE ENOUGH TO SUFFICIENTLY RELIEVE THE OVERFLOW CAUSED BY THE TRANSFER PUMP OR THE MAKEUP FLOW SHALL BE PROVIDED.

Figure 9.2.5-201 Ultimate Heat Sink System Piping and Instrumentation Diagram (Sheet 1 of 2)

Comanche Peak Nuclear Power Plant, Units 3 & 4
COL Application
Part 2, FSAR

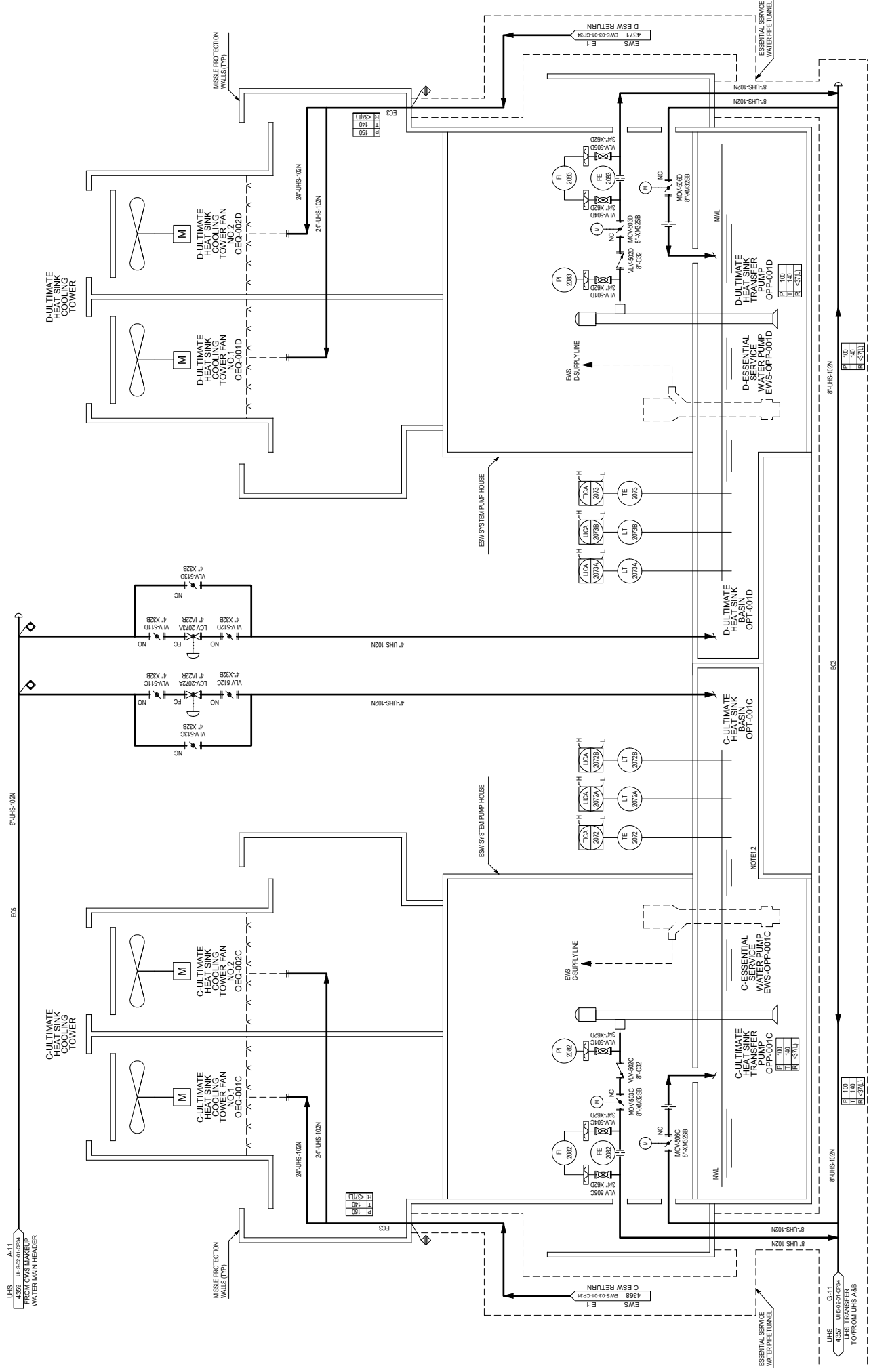

NOTES:
1. ESW PUMP AND TRANSFER PUMP LOCATED IN THE SAME COOLING TOWER PUMP HOUSE ARE PHYSICALLY SEPARATED BY FIRE INTERBARRIER AND NOT TO BE OPERATED TOGETHER BY THE DISTURBANCE SUCH AS FIRE.
2. DRAINAGE SECTION OF THE TOWER BASIN IS TO BE PROVIDED AS A DRAIN ON A DRAIN LINE WHICH IS LARGE ENOUGH TO SUCH PRECLUDE THE OVERFLOW CAUSED BY THE TRANSFER PUMP OR THE MAKEUP FLOW SHALL BE PROVIDED.

Figure 9.2.5-201 Ultimate Heat Sink System Piping and Instrumentation Diagram (Sheet 2 of 2)

Comanche Peak Nuclear Power Plant, Units 3 & 4
COL Application
Part 2, FSAR

9.3 PROCESS AUXILIARIES

This section of the referenced DCD is incorporated by reference with the following departures and/or supplements.

9.3.1.2.1.3 Compressed Gas System

CP COL 9.3(1) Replace the second through fifth paragraphs in **DCD Subsection 9.3.1.2.1.3** with the following.

Nitrogen Gas

The nitrogen gas supply consists of two separate, permanent supply sources: the bulk storage supply and the gas cylinders supply. Both of these supply sources are located in the gas farm. A mobile nitrogen gas tanker temporary connection is supplied. These gas sources supply nitrogen gas to both units.

The bulk nitrogen gas supply is comprised of the nitrogen storage tank, vaporizers, and associated distribution piping and pressure reducing valves. The bulk nitrogen gas system delivers low-pressure nitrogen gas to a header, which is common to the two units. The header in turn supplies local headers to each unit. Each unit has a separate header, which supplies nitrogen to its four steam generators. Another separate header supplies nitrogen to the other low-pressure nitrogen gas users. A nitrogen gas tanker recharges the bulk storage tank periodically. The gas tanker is also available during outage.

The nitrogen gas cylinders provide high-pressure nitrogen gas to the SIS accumulators and the main turbine electro-hydraulic governor accumulator. The nitrogen gas cylinder's supply consists of two bottle-rack trains in parallel. Each bottle-rack train consists of eight or more bottles, each bottle with a pigtail and station valve, which are piped to a manifold. Each bottle rack manifold interfaces with the nitrogen supply distribution header through an isolation valve. The distribution header branches into two lines. One supplies high-pressure nitrogen gas and the other line supplies the low-pressure nitrogen gas.

Hydrogen Gas

The hydrogen gas supply consists of hydrogen gas cylinders, hydrogen gas headers, and distribution piping. The hydrogen gas cylinders deliver hydrogen gas to two separate headers, each header providing hydrogen gas to both units. One header provides hydrogen gas to the primary system users while the other header provides hydrogen to the secondary system users. The hydrogen gas cylinders are located in the compressed gas farm, away from any ignition sources.

Carbon Dioxide Gas

**Comanche Peak Nuclear Power Plant, Units 3 & 4
COL Application
Part 2, FSAR**

The carbon dioxide gas is supplied from the carbon dioxide gas cylinders located close to the equipment if practical or in the compressed gas farm. The carbon dioxide gas cylinders in the gas farm supply carbon dioxide gas to both units.

Miscellaneous Gases

Other gases for the oxygen gas analyzer and the automatic gas analyzers are supplied from gas cylinders located close to the analyzers.

Figure 9.3.1-201 shows the Hydrogen and Nitrogen Gas Supply Configuration.

9.3.1.2.2.3 Compressed Gas System

CP COL 9.3(1) Replace the content of **DCD Subsection 9.3.1.2.2.3** with the following.

The compressed gas system consists of gas sources as described in Subsection 9.3.1.2.1.3 and the distribution headers, distribution piping, and the associated valves and instrumentation.

9.3.6 Combined License Information

Replace the content of **DCD Subsection 9.3.6** with the following.

CP COL 9.3(1) **9.3(1) Compressed Gas System**

*This COL item is addressed in **Subsection 9.3.1.2.1.3**, **9.3.1.2.2.3** and **Figure 9.3.1-201**.*

9.3(2) Deleted from the DCD.

9.3(3) Deleted from the DCD.

9.3(4) Deleted from the DCD.

9.3(5) Deleted from the DCD.

9.3(6) Deleted from the DCD.

9.3(7) Deleted from the DCD.

**Comanche Peak Nuclear Power Plant, Units 3 & 4
COL Application
Part 2, FSAR**

Inside Compressed Gas Farm

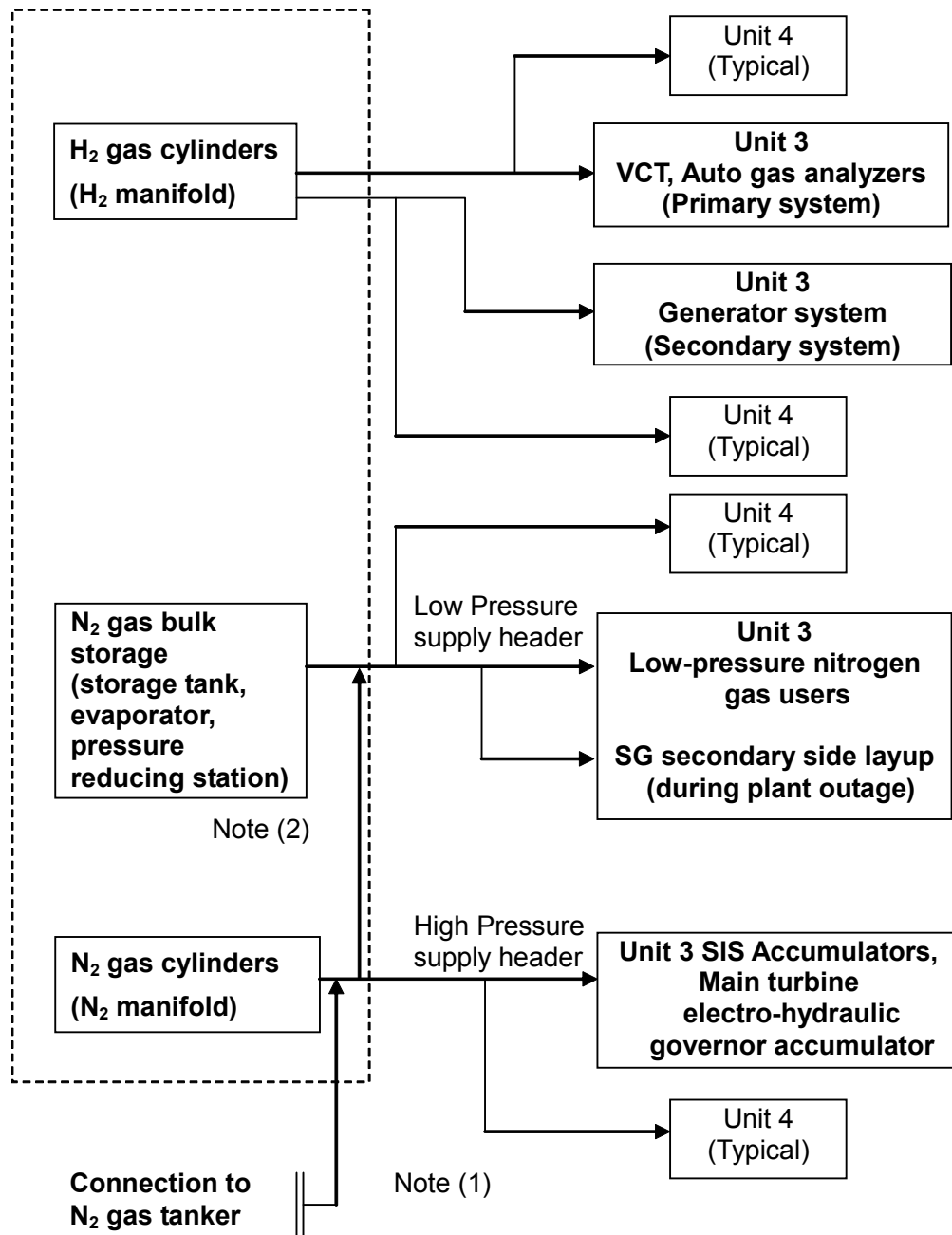

Note (1): N₂ gas supply line for charging N₂ to the accumulators and for charging into SG secondary side for layup

Note (2): Backup supply line for the low-pressure nitrogen gas users or nitrogen gas supply line for SG secondary layup.

Figure 9.3.1-201 Hydrogen and Nitrogen Gas Supply Configuration

**Comanche Peak Nuclear Power Plant, Units 3 & 4
COL Application
Part 2, FSAR**

9.4 AIR CONDITIONING, HEATING, COOLING, AND VENTILATION SYSTEMS

This section of the referenced DCD is incorporated by reference with the following departures and/or supplements.

9.4.1.2 System Description

CP COL 9.4(4) Replace the second sentence of the first paragraph in **DCD Subsection 9.4.1.2** with the following.

The capacity of heating coils that are affected by site specific conditions is shown in **Table 9.4-201**.

9.4.3.2.1 Auxiliary Building HVAC System

CP COL 9.4(4) Replace the second sentence of the first paragraph in **DCD Subsection 9.4.3.2.1** with the following.

The capacity of cooling and heating coils that are affected by site specific conditions is shown in **Table 9.4-201**.

9.4.3.2.2 Non-Class 1E Electrical Room HVAC System

CP COL 9.4(4) Replace the second sentence of the first paragraph in **DCD Subsection 9.4.3.2.2** with the following.

The capacity of cooling and heating coils that are affected by site specific conditions is shown in **Table 9.4-201**.

9.4.3.2.3 Main Steam/Feedwater Piping Area HVAC System

CP COL 9.4(4) Replace the second sentence of the first paragraph in **DCD Subsection 9.4.3.2.3** with the following.

**Comanche Peak Nuclear Power Plant, Units 3 & 4
COL Application
Part 2, FSAR**

The capacity of cooling and heating coils that are affected by site specific conditions is shown in [Table 9.4-201](#).

9.4.3.2.4 Technical Support Center HVAC System

CP COL 9.4(4) Replace the second sentence of the first paragraph in [DCD Subsection 9.4.3.2.4](#) with the following.

The capacity of cooling and heating coils that are affected by site specific conditions is shown in [Table 9.4-201](#).

9.4.5 Engineered Safety Feature Ventilation System

CP COL 9.4(6) Delete the third paragraph and insert the following text to the end of the list of ESF ventilation systems in first paragraph of [DCD Subsection 9.4.5](#).

- UHS ESW Pump House Ventilation System
-

CP COL 9.4(6) Add the following new subsection after [DCD Subsection 9.4.5.1.1.5](#).

9.4.5.1.1.6 UHS ESW Pump House Ventilation System

The UHS ESW pump house ventilation system provides and maintains the proper environmental conditions within the required temperature range (40°F – 120°F) to support the operation of the instrumentation and control equipment and components in the individual UHS ESW pump houses during a design basis accident and LOOP with outside ambient design temperature condition of 0% temperature exceedance values.

9.4.5.2.2 Class 1E Electrical Room HVAC System

CP COL 9.4(4) Replace the second sentence of the first paragraph in [DCD Subsection 9.4.5.2.2](#) with the following.

The capacity of heating coils that are affected by site specific conditions is shown in [Table 9.4-201](#).

**Comanche Peak Nuclear Power Plant, Units 3 & 4
COL Application
Part 2, FSAR**

9.4.5.2.3 Safeguard Component Area HVAC System

CP COL 9.4(4) Replace the third sentence of the second paragraph in **DCD Subsection 9.4.5.2.3** with the following.

The capacity of heating coils that are affected by site specific conditions is shown in **Table 9.4-201**.

9.4.5.2.4 Emergency Feedwater Pump Area HVAC System

CP COL 9.4(4) Replace the fourth sentence of the second paragraph in **DCD Subsection 9.4.5.2.4** with the following.

The capacity of heating coils that are affected by site specific conditions is shown in **Table 9.4-201**.

9.4.5.2.5 Safety Related Component Area HVAC System

CP COL 9.4(4) Replace the third sentence of the second paragraph in **DCD Subsection 9.4.5.2.5** with the following.

The capacity of heating coils that are affected by site specific conditions is shown in **Table 9.4-201**.

CP COL 9.4(6) Add the following new subsection after **DCD Subsection 9.4.5.2.5**.

9.4.5.2.6 UHS ESW Pump House Ventilation System

The UHS ESW pump house ventilation system is shown in **Figure 9.4-201** and the equipment design data is presented in **Table 9.4-202**.

There are four separate and independent UHS ESW pump houses and each has its own ventilation system. Each UHS ESW pump house ventilation system has an exhaust fan that provides 100 percent of the ventilation requirements for the associated ESW pump room. The UHS transfer pump room within the UHS ESW pump house has an exhaust fan that provides 100 percent of the ventilation

Comanche Peak Nuclear Power Plant, Units 3 & 4
COL Application
Part 2, FSAR

requirements for the UHS transfer pump room. The ESW pump room and the UHS transfer pump room each have separate independent supply and exhaust openings to the outside.

Unit heaters are provided in the UHS transfer pump room and the ESW pump room to maintain a minimum room temperature to prevent the freezing of instrument lines, the wet pipe sprinkler system, and the standpipe hose station.

CP COL 9.4(6) Add the following new subsection after **DCD Subsection 9.4.5.3.5**

9.4.5.3.6 UHS ESW Pump House Ventilation System

- The ESW pump room exhaust fan and the UHS transfer pump room exhaust fan located in each UHS ESW pump house are powered by the different Class 1E buses.
 - The ESW pump room exhaust fan and the UHS transfer pump room exhaust fan are separated by a three-hour fire rated barrier. Therefore, each fan powered by different Class 1E power supplies is protected and remains functional in the event of a fire in either room.
 - The safety function of the UHS ESW pump house ventilation system is assured by the physical separation provided by the four separate and independent UHS ESW pump houses. All ventilation system equipment and components are classified as equipment class 3, seismic category I.
 - The ESW pump room exhaust fans and the UHS transfer pump room exhaust fans are capable of performing its safety function under all associated design basis accidents coincident with LOOP.
 - Failure of a single active component in one of the UHS ESW pump house ventilation system exhaust fans does not result in a loss of the system's safety function.
 - The UHS ESW pump house ventilation system components are protected from tornado generated missiles by their location inside a seismic category I structure.
 - Backdraft dampers are capable of withstanding the affects of tornado wind and atmospheric differential pressure loading.
-

CP COL 9.4(6) Add the following new subsection after **DCD Subsection 9.4.5.4.5**.

9.4.5.4.6 UHS ESW Pump House Ventilation System

The general requirements in Subsection 9.4.5.4 apply.

**Comanche Peak Nuclear Power Plant, Units 3 & 4
COL Application
Part 2, FSAR**

CP COL 9.4(6) Add the following new subsection after **DCD Subsection 9.4.5.5.5**.

9.4.5.5.6 UHS ESW Pump House Ventilation System

The following instrumentation serving the UHS ESW pump houses includes:

- Alarm on low airflow for ESW pump room or UHS transfer pump room.
- Indication of the status of the exhaust fans.
- Alarm on high room temperature in ESW pump room or UHS transfer pump room.
- Alarm on low room temperature in ESW pump room or UHS transfer pump room.

9.4.6.2.4.1 Containment Low Volume Purge System

CP COL 9.4(4) Replace the second sentence of the first paragraph in **DCD Subsection 9.4.6.2.4.1** with the following.

The capacity of cooling and heating coils that are affected by site specific conditions is shown in **Table 9.4-201**.

9.4.6.2.4.2 Containment High Volume Purge System

CP COL 9.4(4) Replace the second sentence of the first paragraph in **DCD Subsection 9.4.6.2.4.2** with the following.

The capacity of cooling and heating coils that are affected by site specific conditions is shown in **Table 9.4-201**.

9.4.7 Combined License Information

Replace the content of **DCD Subsection 9.4.7** with the following.

9.4(1) Deleted from the DCD.

9.4(2) Deleted from the DCD.

9.4(3) Deleted from the DCD.

Comanche Peak Nuclear Power Plant, Units 3 & 4
COL Application
Part 2, FSAR

CP COL 9.4(4) **9.4(4)** *Capacity of cooling and heating coils that are affected by site specific conditions*
This COL item is addressed in *Subsections 9.4.1.2, 9.4.3.2.1, 9.4.3.2.2, 9.4.3.2.3, 9.4.3.2.4, 9.4.5.2.2, 9.4.5.2.3, 9.4.5.2.4, 9.4.5.2.5, 9.4.6.2.4.1, 9.4.6.2.4.2 and Table 9.4-201.*

9.4(5) *Deleted from the DCD.*

CP COL 9.4(6) **9.4(6)** *Information of UHS ESW pump house ventilation system*
This COL item is addressed in *Subsections 9.4.5, 9.4.5.1.1.6, 9.4.5.2.6, 9.4.5.3.6, 9.4.5.4.6, 9.4.5.5.6, Table 9.4-202 and Figure 9.4-201.*

Comanche Peak Nuclear Power Plant, Units 3 & 4
COL Application
Part 2, FSAR

CP COL 9.4(4)

Table 9.4-201 (Sheet 1 of 2)

Equipment Design Data

Main Control Room Air Handling Unit

Heating Coil Capacity	37 kW
-----------------------	-------

Auxiliary Building Air Handling Unit

Cooling Coil Capacity	9,200,000 Btu/hr
Heating Coil Capacity	4,750,000 Btu/hr (Steam)

Non-Class 1E Electrical Room Air Handling Unit

Cooling Coil Capacity	1,330,000 Btu/hr
Heating Coil Capacity	Non heating

Main Steam / Feedwater Piping Area Air Handling Unit

Cooling Coil Capacity	450,000 Btu/hr
Heating Coil Capacity	9 kW

Technical Support Center Air Handling Unit

Cooling Coil Capacity	550,000 Btu/hr
Heating Coil Capacity	30 kW

Class 1E Electrical Room Air Handling unit

Heating Coil Capacity	37 kW - Train A, B
	55 kW - Train C, D

Safeguard Component Area Air Handling Unit

Heating Coil Capacity	24 kW
-----------------------	-------

Emergency Feedwater Pump (M/D) Area Air Handling Unit

Heating Coil Capacity	2 kW
-----------------------	------

Emergency Feedwater Pump (T/D) Area Air Handling Unit

Heating Coil Capacity	4.5 kW
-----------------------	--------

**Comanche Peak Nuclear Power Plant, Units 3 & 4
COL Application
Part 2, FSAR**

CP COL 9.4(4)

Table 9.4-201 (Sheet 2 of 2)

Equipment Design Data

Safety Related Component Area Air Handling Unit		
Penetration Area Air Handling Unit Heating Coil Capacity	29 kW	
Annulus Emergency Filtration Unit Area Air Handling Unit Heating Coil Capacity	10 kW	
Charging Pump Area Air Handling Unit Heating Coil Capacity	6 kW	
CCW Pump Area Air Handling Unit Heating Coil Capacity	3 kW	
Essential Chiller Unit Area Air Handling Unit Heating Coil Capacity	4.5 kW	
SFP Pump Area Air Handling Unit Heating Coil Capacity	5 kW	
Containment Low Volume Purge Air Handling Unit		
Cooling Coil Capacity	190,000 Btu/hr	
Heating Coil Capacity	30 kW	
Containment High Volume Purge Air Handling Unit		
Cooling Coil Capacity	2,820,000 Btu/hr	
Heating Coil Capacity	440 kW	

**Comanche Peak Nuclear Power Plant, Units 3 & 4
COL Application
Part 2, FSAR**

CP COL 9.4(6)

Table 9.4-202

UHS ESW Pump House Ventilation System Equipment Design Data

ESW Pump Room Exhaust Fan

Number of Fans	4
Equipment Class	3
Seismic Category	I
Airflow Capacity	34,000 cfm
Fan Type	Propeller

UHS Transfer Pump Room Exhaust Fan

Number of Fans	4
Equipment Class	3
Seismic Category	I
Airflow Capacity	2,400 cfm
Fan Type	Propeller

ESW Pump Room Unit Heater

Number of Units	8 (2 per pump room)
Equipment Class	3
Seismic Category	I
Capacity	24 kW

UHS Transfer Pump Room Unit Heater

Number of Units	4
Equipment Class	3
Seismic Category	I
Capacity	3.5 kW

Comanche Peak Nuclear Power Plant, Units 3 & 4
 COL Application
 Part 2, FSAR

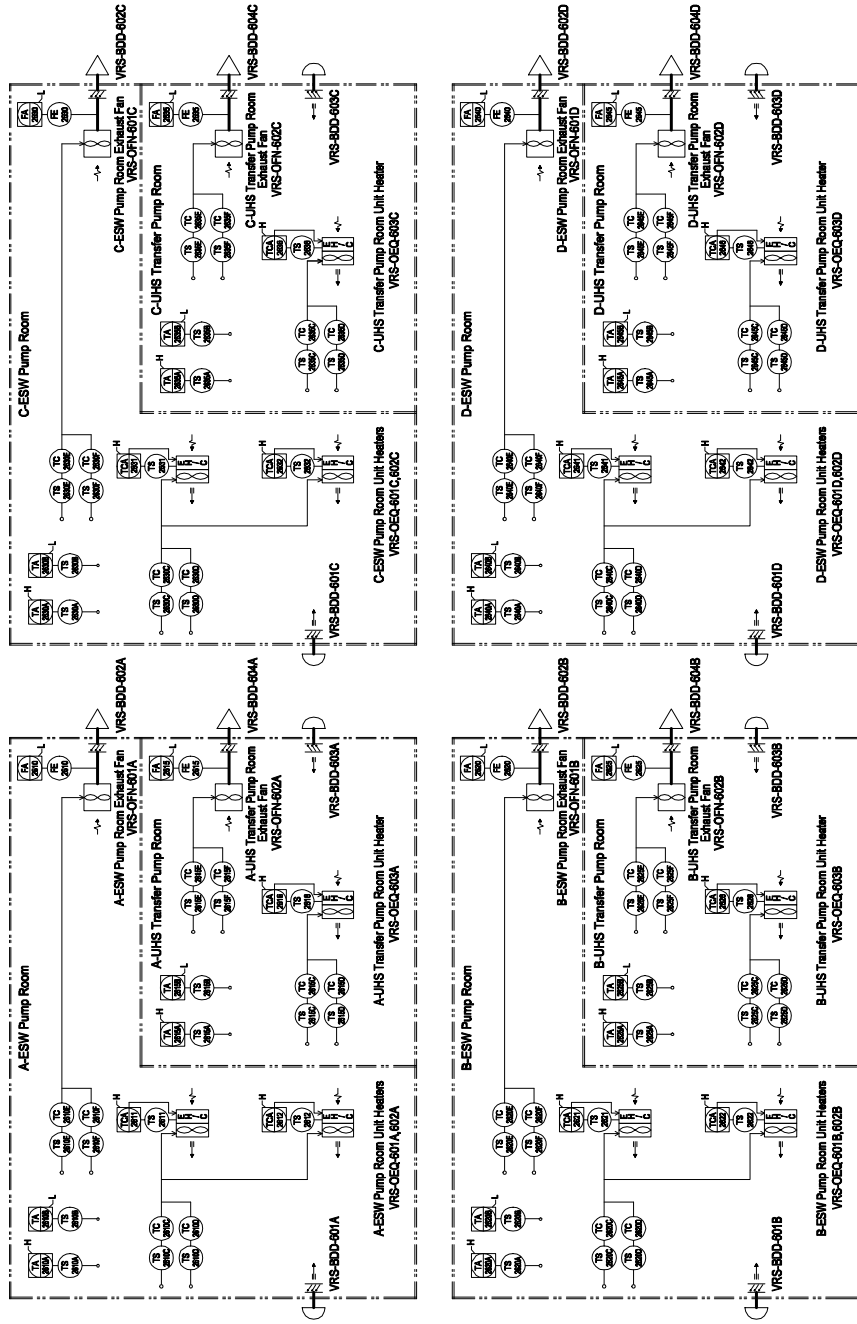

CP COL 9.4(6)

Figure 9.4-201 UHS ESW Pump House Ventilation System Flow Diagram

**Comanche Peak Nuclear Power Plant, Units 3 & 4
COL Application
Part 2, FSAR**

9.5 OTHER AUXILIARY SYSTEMS

This section of the referenced DCD is incorporated by reference with the following departures and/or supplements.

9.5.1 Fire Protection Program

CP COL 9.5(1) Replace the third sentence of the second paragraph in **DCD Subsection 9.5.1** with the following.

The fire protection program (FPP) and implementation of FPP elements for CPNPP Units 3 and 4 are presented in **Subsection 9.5.1.6**.

9.5.1.2 System Description

CP COL 9.5(1) Replace the fourth paragraph in **DCD Subsection 9.5.1.2** with the following.

Table 9.5.1-1R is a point-by-point comparison of the conformance of the fire protection program with the guidelines of RG 1.189. **Table 9.5.1-2R** is a point-by-point comparison of the conformance of the fire protection program with the guidelines of NFPA 804 (Reference 9.5.1-14).

9.5.1.2.1 Facility Features for Fire Protection

CP COL 9.5(2) Replace the eighteenth paragraph in **DCD Subsection 9.5.1.2.1** with the following.

Outdoor oil-filled transformers for CPNPP Units 3 and 4 are separated from the T/B with a 3-hour fire rated barrier. A 1-hour fire rated barrier is located between each transformer. Each of the main transformers, unit auxiliary transformers, reserve auxiliary transformers and main generator excitation transformer is protected with a thermally activated automatic water spray system. The transformer arrangement follows the guidance of RG 1.189 and NFPA 804. Provision for drainage and oil spill containment is in accordance with NFPA 804 and IEEE 980 (**Reference 9.5.1-206**)

9.5.1.2.2 Fire Protection Water Supply System

**Comanche Peak Nuclear Power Plant, Units 3 & 4
COL Application
Part 2, FSAR**

CP COL 9.5(2) Replace the third paragraph in **DCD Subsection 9.5.1.2.2** with the following.

The fire protection water supply system (FSS) for CPNPP Units 3 and 4 is depicted in **Figure 9.5.1-201**. The make-up capability for the storage tanks from the water treatment system is capable of refilling an empty tank within an eight-hour period. Each storage tank has sufficient capacity to support two hours of the largest sprinkler system operation plus hose stream allowances and provides excess capacity to support normal operations without affecting the amount of water reserved for the design requirements. This allows system testing and periodic activities, such as hydrant flushing, without adversely affecting the ability to retain sufficient water to meet the total system design flow requirement in the event of a fire. The fire water storage tank design complies with NFPA 22.

The design parameters associated with primary fire protection water supply equipment are the followings.

- The total rated head of fire pumps are 350 feet of water at a flow of 2500 gpm
- The water storage for largest sprinkler system operation and hose streams is 318,180 gallons
- The eight-hour storage refill requirement is 318,180 gallons
- The storage tank nominal capacity is 500,000 gallons

9.5.1.2.3 Fire Water Supply Piping, Yard Piping, and Yard Hydrants

CP COL 9.5(2) Replace the seventh paragraph in **DCD Subsection 9.5.1.2.3** with the following.

The yard main loop is shown in **Figure 9.5.1-202**. The underground yard piping is 12-inch diameter high-density polyethylene piping that is very resistant to corrosion and biofouling. A minimum of 6-inch diameter piping supplies each hydrant and is provided with an isolation valve for hydrant servicing. Building feeds have a minimum 8-inch diameter.

9.5.1.2.4 Manual Suppression Means

CP COL 9.5(2) Replace the second and third sentences of third paragraph in **DCD Subsection 9.5.1.2.4** with the following.

That standpipe can be isolated from the normal fire protection water source after a SSE and the standpipe can be aligned to the ESWS for water supply of at least two hose streams of 75 gpm each. To support two hours operation of these hose streams, the ESWS is designed to supply at least 18,000 gallons for this need.

Comanche Peak Nuclear Power Plant, Units 3 & 4
COL Application
Part 2, FSAR

9.5.1.3 Safety Evaluation

CP COL 9.5(1) Replace the eight paragraph in **DCD Subsection 9.5.1.3** with the following

The Final FHA and safe-shutdown evaluation based on the final plant cable routing, fire barrier ratings, fire loading, ignition sources, purchased equipment and equipment arrangement will be performed. The final FHA and safe-shutdown evaluation will include a review against the assumptions and requirements stated in the initial FHA and safe-shutdown evaluation. The final FHA and safe-shutdown evaluation will also include a detailed post-fire safe-shutdown circuit analysis performed and documented using a methodology similar to that described in NEI 00-01, "Guide for Post-Fire Safe-Shutdown Circuit Analysis," using as-built data. The final FHA will be performed in accordance with Table 13.4-201.

CP COL 9.5(1) Add the following new subsections after **DCD Subsection 9.5.1.5**.

9.5.1.6 Fire Protection Program

During construction, a site construction FPP is in place that addresses the requirements of Chapter 11, NFPA 804. This initial FPP is under the responsibility of the construction superintendent. Program responsibility is transferred to the Site Vice President as operational testing approaches. The CPNPP senior management position responsible for the operational program is the Site Vice President. The Site Vice President has delegated to the Operations Review Committee the responsibility to assess the effectiveness of the FPP, which is accomplished through periodic audits. Recommendations and the findings from these audits are reported to the Site Vice President.

The CPNPP FPP is developed in accordance with guidance provided in RG 1.189, as described in the following sections. The CPNPP FPP policy is captured in a formal plant document that defines management authorities, authority for conflict resolution, programmatic responsibilities, and establishes the general policy for the site FPP.

The CPNPP FPP is established to ensure that a fire will not affect safe-shutdown capabilities and will not endanger the health and safety of the public. Fire protection at CPNPP is accomplished by using a defense-in-depth approach to include fire detection, extinguishing systems and equipment, administrative controls, procedures, and trained personnel.

In accordance with Table 13.4-201, procedures for implementing the CPNPP FPP are developed and implemented prior to start-up. All elements of the CPNPP FPP are reviewed every 2 years and updated as necessary.

Comanche Peak Nuclear Power Plant, Units 3 & 4
COL Application
Part 2, FSAR

9.5.1.6.1 Organization

9.5.1.6.1.1 Plant Manager

The Plant Manager has the responsibility for the development and implementation of the FPP for operations at CPNPP. These responsibilities have been delegated to the Director, Maintenance.

9.5.1.6.1.2 Director, Maintenance

The Director, Maintenance, is responsible to the Plant Manager for the development and implementation of the FPP. The Director, Maintenance, has assigned to the Maintenance Team Manager the responsibility of assuring the overall implementation of the FPP. The Director, Maintenance, has assigned to the Manager, Technical Support the overall responsibility for the development of the CPNPP FPP.

9.5.1.6.1.3 Maintenance Team Manager

The assigned Maintenance Team Manager is responsible to the Director, Maintenance, for the overall implementation of the FPP. These duties and responsibilities include the following:

- Assures the implementation of periodic inspections to minimize the amount of combustibles in safety-related areas; determine the effectiveness of housekeeping practices; assure the availability and acceptable condition of all FPSs/equipment; and assure that prompt actions are taken to correct conditions adverse to fire protection and preclude their recurrence
- Ensure that periodic testing and maintenance of FPSs and equipment is being performed and evaluated for availability and acceptability
- Develop the FPP administrative procedures and the FPSs and equipment testing and maintenance requirements
- Assures the implementation of the administrative procedures of the FPP such that the ability to safely shutdown the plant in the event of a fire is not compromised due to hot work, systems, or equipment being impaired, compensatory measures, or the control of transient combustible materials and/or flammable/combustible liquids and gases

9.5.1.6.1.4 Manager, Technical Support

The Manager, Technical Support, is responsible to the Director, Maintenance, for the overall development and coordination of the CPNPP FPP. These duties and responsibilities include the following.

- The continued maintenance of the fire protection licensing documents and the evaluation of regulatory requirements for impact

Comanche Peak Nuclear Power Plant, Units 3 & 4
COL Application
Part 2, FSAR

- The continued implementation of the fire protection engineering requirements such that modifications and changes do not affect the ability to safely shutdown the plant in the event of a fire

9.5.1.6.1.5 Nuclear Training Manager

The Nuclear Training Manager reports to the Site Vice President and assists in the development and implementation of fire protection training programs for operating personnel and the fire brigade at CPNPP, as requested. The Nuclear Training Manager documents and maintains records of the fire protection training of operations personnel and fire brigade.

9.5.1.6.1.6 CPNPP Fire Brigade

CPNPP maintains an organized fire brigade to deal with fires and related emergencies when they occur. The minimum staffing level for the CPNPP fire brigade is adequate to address the potential magnitude of a fire emergency at CPNPP. For additional support, arrangements exist with offsite departments to provide backup to the CPNPP fire brigade. The CPNPP fire brigade consists of several fire teams with a minimum of five members for each team. This fire team size is consistent with the equipment that is used in responding to a fire event (2 ½ in. hose station, 1 ½ in. hose station, and wheeled and hand held portable extinguishers). Each fire team has a designated fire team leader to direct the action of the fire team. The fire team leader has ready access to keys to any locked doors. The fire team leader maintains close communication with the Shift Manager, keeping him or her apprised of the situation at the fire event. Two fire brigade members perform the primary fire fighting function (i.e., serve as fire attack team operating the fire suppression equipment). The remaining two fire brigade members serve as the rapid intervention team, providing backup, and rescue functions as required.

A sufficient number of operations personnel receive fire brigade training and qualify to be members of the CPNPP fire brigade to allow the five person fire team consisting of the fire team leader and four additional personnel to be on duty during each working shift and at periods when the plant is shutdown. The fire brigade does not include the Shift Manager and the other member(s) of the minimum shift crew necessary for the safe-shutdown of the unit and any personnel required for other essential functions during a fire emergency. Personnel from other departments may also be used to staff the fire brigade if they have received fire brigade training and meet all qualifications for CPNPP fire brigade membership. The fire brigade may be one less than the minimum requirements for a period of time not to exceed 2 hours in order to accommodate an unexpected absence of on-duty crew members, provided immediate action is taken to restore the brigade composition to within the minimum requirements. This provision does not permit the brigade to be unmanned below the minimum upon shift change due to an oncoming member being late or absent.

Comanche Peak Nuclear Power Plant, Units 3 & 4
COL Application
Part 2, FSAR

An incident commander designated by plant management and trained in emergency services incident management systems ([Reference 9.5.1-205](#)) assumes the overall responsibility in the event of a fire emergency and provides advice and guidance to the shift manager. The incident commander is responsible for incident command activities and for making the following specific recommendations to the shift manager based upon assessment of the magnitude of the fire emergency from reports received from the fire team leader.

- Safe-shutdown of the plant if required
- Implementation of the Emergency Plan
- Notification of management
- Requesting assistance from off duty fire teams if deemed necessary
- Contacting local fire departments if required

If the decision to implement the emergency plan due to a fire emergency is made, the incident commander is designated the Emergency Coordinator until relieved by a designated alternate. However, the incident commander will continue to receive reports from the fire brigade leader at the fire site while coordinating other emergency activities with the Emergency Coordinator. To qualify as a member of the CPNPP fire brigade, individuals must be available to respond to alarms and meet all qualification and training requirements.

9.5.1.6.1.7 Offsite Fire Departments and Mutual Aid

The CPNPP fire brigade has adequate training, equipment, and staffing to fulfill the role of first responder to all fire events at CPNPP. For potential events where additional fire response may be desired, arrangements with offsite fire services exist prior to pre-operational testing to augment the onsite fire fighting capabilities, consistent with the fire hazards analysis and pre-fire planning documents. Local offsite fire department personnel who provide back up for manual fire fighting resources are trained to assure familiarity with CPNPP and have the following capabilities.

- Personnel and equipment with capacities consistent with those assumed in the CPNPP fire hazards analysis and pre-fire plans
- Hose threads or adapters to connect with onsite hydrants, hose couplings, and standpipe risers

CPNPP establishes prior to pre-operational testing, formal written mutual aid agreements between the utility and the offsite fire departments that are listed in the fire hazards analysis and pre-fire plans as providing a support response to a plant fire. These agreements delineate fire protection authorities, responsibilities, and accountabilities with regard to responding to plant fire or emergency events, including the fire event command structure between the plant fire brigade and offsite responders.

Comanche Peak Nuclear Power Plant, Units 3 & 4
COL Application
Part 2, FSAR

CP COL 9.5(1)
CP COL 9.5(3)

9.5.1.6.1.8 Fire Brigade Equipment

The members of the fire brigade receive the appropriate equipment to enable them to perform the required response duties. The selection of equipment includes the consideration of the nature of the hazards in the facility and the required fire response actions. Storage space for the fire brigade equipment is such that ready accessibility to the fire fighting equipment exists. A written equipment list that the industrial fire brigade is expected to use is maintained onsite, reviewed annually, and updated as necessary. This list includes the location of the equipment and procedures for obtaining the equipment when needed.

The fire brigade equipment includes thermal protective clothing and protective equipment in sufficient quantities and sizes to fit each fire brigade member expected to respond to a fire event. The protective clothing including helmets, gloves, and footwear is in accordance with NFPA 1971, "Standard on Protective Ensemble for Structural Fire Fighting" (Reference 9.5.1-202). All fire brigade members responding to a fire event use self-contained breathing apparatus and personal alert safety systems devices in accordance with NFPA 1982, "Standard on Personal Alert Safety Systems" (Reference 9.5.1-204) and with NFPA 1981, "Standard on Open-Circuit Self-Contained Breathing Apparatus for Fire and Emergency Services" (Reference 9.5.1-203). Self-contained breathing apparatus's are approved by the National Institute for Occupational Health and Safety and Mine Safety and Health Administration with minimum service duration of 30 minutes and operate in the positive pressure mode only. At least 10 masks are readily available for fire brigade personnel. Also, a 1-hour supply of breathing air in extra bottles is located at the plant for each self-contained breathing apparatus. In addition, an onsite 6-hour supply of reserve air is provided for fire brigade personnel and is arranged to permit quick and complete replenishment of exhausted air supply bottles as they are returned.

All fire brigade equipment undergoes inspection and maintenance at least annually. Operation and maintenance manuals and maintenance reports for the fire brigade equipment are retained on file and available to the fire brigade. Thermal protective clothing and protective equipment are used and maintained in accordance with manufacturer's instructions and subject to a maintenance and inspection program.

Fire brigade members using self-contained breathing apparatus operate in teams of two or more who are in communication with each other through visual, audible, physical, safety guide rope, electronic, or other means to coordinate their activities and are in close proximity to each other to provide assistance in case of an emergency.

In addition to the appropriate protective clothing, fire brigade equipment provided includes fire hoses, the appropriate fire hose nozzles for electric plant usage, portable fire extinguishers, wheeled fire extinguishers, portable exhaust fans, portable emergency communication equipment, portable lighting, and fire fighting foam carts suitable for responding to fires involving hydrocarbon lube oil.

Comanche Peak Nuclear Power Plant, Units 3 & 4
COL Application
Part 2, FSAR

CP COL 9.5(1) **9.5.1.6.1.9 Fire Watch Personnel**

Fire watches provide for observation and control of fire hazards associated with hot work, temporary modifications, or they may act as compensatory measures for degraded FPSs and features.

9.5.1.6.2 Fire Protection Training

Each nuclear plant employee has a responsibility to prevent, detect, and suppress fires. General site employee training introduces all personnel to the elements of the site's FPP, including the responsibilities of the fire protection staff. Training includes information on the types of fires and related extinguishing agents, specific fire hazards at the site, and actions in the event of a fire suppression system actuation. Fire brigade training is conducted to assure that a qualified response is available at any time for a potential fire event at CPNPP. Personnel with specific duties within the FPP, such as fire watch personnel, FPS maintenance and testing, providing of training to fire brigade personnel, conducting independent assessment of the CPNPP FPP, and maintaining fire protection records are provided with the necessary and appropriate level of training to carry out their responsibilities.

9.5.1.6.2.1 Fire Brigade Training

A training program is in place to assure that the capability to fight potential fires is developed and documented. The program consists of a classroom instruction program supplemented with periodic classroom retraining and practical training in fire fighting and periodic fire drills. Classroom instruction and training is conducted by qualified individuals knowledgeable of fighting the types of fires that could occur in the plant and in using appropriate fire fighting equipment.

9.5.1.6.2.1.1 Fire Brigade Classroom Instruction

Fire brigade members receive classroom instruction in fire protection and fire fighting techniques at planned meetings. Instruction includes the following.

- Identification of fire hazards and associated types of fires that are possible in the plant and the potential location of such hazards
- Identification of fire fighting equipment within each fire area, and familiarization with the layout of the plant including ingress and egress routes to each area
- The proper use of fire fighting equipment and the correct method of fighting each type of fire, including electrical fires, cable and cable tray fires, hydrogen fires, flammable liquids, waste/debris fires, fires involving radioactive materials, and record file fires
- Review of CPNPP pre-fire plans and review of each individual's responsibilities

Comanche Peak Nuclear Power Plant, Units 3 & 4
COL Application
Part 2, FSAR

- The proper use of communication, lighting, ventilation, and emergency breathing equipment
- The direction and coordination of the fire fighting activities
- The toxic and radiological characteristics of expected products of combustions
- The proper method of fighting fires inside buildings and tunnels
- Review of fire fighting procedures and procedure changes
- Review of fire protection-related plant modifications and changes in fire fighting plans

All plant employees receive instruction once a year in fire protection responsibilities. The instruction includes, as appropriate, the fire protection plan, evacuation routes, and the procedure for reporting a fire.

Security personnel receive training including entry procedures for outside fire departments and crowd control for people exiting the station in initial and periodic refresher training sessions.

Construction personnel and temporary employees receive instruction including alarm responses, evacuation routes, and the procedure for reporting fires prior to performing work at the plant.

Offsite fire organizations receive training on basic radiation principles, practices, and typical radiation hazards applicable for fighting fires at the plant.

9.5.1.6.2.1.2 Fire Brigade Practical Fire Fighting Training

Annual practice sessions for fire brigade members provide hands-on experience with the proper method of fighting various types of fires similar to those that might occur in a nuclear power plant. These sessions involve actual fire extinguishment and the use of emergency breathing apparatus and expose fire brigade members to actual fire fighting conditions.

The practical training places emphasis on activities that are appropriate to brigade members fighting fires in safety-related nuclear power plant areas.

9.5.1.6.2.1.3 Fire Drills

Fire brigade drills occur on a quarterly (every three months) basis at CPNPP. Drills are of two types: announced and unannounced. Drills allow fire brigade individuals to practice together as a team. A sufficient number of drills occur within a period of three months so that all fire teams participate in at least one drill. Each individual member of a fire brigade is required to participate in at least two drills per year. Offsite fire organizations are included in a fire brigade drill at least annually. Each drill has specific training objectives established prior to the drill.

Comanche Peak Nuclear Power Plant, Units 3 & 4
COL Application
Part 2, FSAR

Afterwards, to determine how well the training objectives are met, a drill critique is held which includes the following.

- Assessment of fire alarm effectiveness, time required to notify and assemble fire brigade, and selection, placement, and use of equipment
- Assessment of brigade leader's effectiveness in directing the fire fighting effort
- Assessment of brigade member's knowledge of fire fighting strategy, procedures, and use of equipment in the area assumed to contain the fire

Employees who receive plant access authorization receive instruction in fire response including evacuation during initial and annual refresher training. Demonstration of evacuation (site evacuation/accountability) is an element of the CPNPP Emergency Plan.

9.5.1.6.2.1.4 Fire Watch Training

Specific fire watch training includes instruction on fire watch duties, responsibilities, and required actions for both one-hour roving and continuous fire watches. The training includes hands-on training on a practice fire with the extinguishing equipment to be used while on fire watch. For fire watch personnel who are trained to provide compensatory action fire watches, the training includes recordkeeping requirements.

9.5.1.6.2.1.5 Fire Protection Training Records

Records of training provided for each fire brigade member, including drill critiques, are maintained for at least 3 years to ensure that each member of the fire brigade receives training in all parts of the program. These records are available for NRC inspection.

9.5.1.6.3 Qualifications of Fire Protection Personnel

The Manager, Technical Support, is responsible to the Director, Maintenance, and has available staff personnel knowledgeable in both fire protection and nuclear safety for overall the development and coordination of the CPNPP FPP. The staff includes personnel prepared by training and experience in fire protection and in nuclear plant safety with proven capability to provide a comprehensive approach in directing the FPP for the nuclear power plant. The staff includes at least one fire protection engineer (or a consultant) who is a graduate of an engineering curriculum of accepted standing and satisfies the eligibility requirements as a Member in the Society of Fire Protection Engineers.

The assigned Maintenance Team Manager, responsible to the Director, Maintenance, for the overall implementation of the FPP, has available personnel adequately trained in the administrative procedures that implement the FPP and the emergency procedures relative to fire protection that are knowledgeable in both fire protection and nuclear safety.

Comanche Peak Nuclear Power Plant, Units 3 & 4
COL Application
Part 2, FSAR

Fire brigade members must be able to satisfactorily complete a physical examination for performing strenuous activity and the fire brigade training prior to being assigned to the fire brigade. Completion of initial fire brigade training is required prior to assigning an individual to the fire brigade. The brigade leader and at least two brigade members have sufficient training in or knowledge of plant systems to understand the effects of fire and fire suppressants on safe-shutdown capability. The brigade leader is competent as evidenced by possession of an operator's license or equivalent knowledge of plant systems to assess the potential safety consequences of a fire and advise MCR personnel. To maintain fire brigade membership, personnel must satisfactorily complete periodic physical exams, participate in at least two fire drills per year, and satisfactorily complete yearly retraining.

Personnel responsible for training of the fire brigade have the knowledge, suitable training, and experience for such work. Personnel responsible for maintenance and testing of the FPSs have the appropriate training and experience for such work.

Personnel assigned fire watch duties have completed training that provides instruction on fire watch duties, responsibilities, and required actions for both 1-hour roving and continuous fire watches. Fire watch qualifications include hands-on training on a practice fire with the extinguishing equipment used while on fire watch. If fire watches serve as compensatory actions, the fire watch training includes recordkeeping requirements.

9.5.1.6.4 Fire Protection Procedures

The Manager, Technical Support, is responsible for the development of procedures for fire protection. The assigned Maintenance Team Manager is responsible for the implementation of fire protection procedures.

Records of FPP-related changes in the facility, changes in procedures, and tests and experiments made in accordance with the standard fire protection license condition are maintained. These records include the written evaluation that provides the bases for the determination that the change does not adversely affect safe-shutdown capability.

A current record of all such changes is available to NRC inspectors upon request. All changes to the approved program are reported along with the FSAR revisions required by 10 CFR 50.71(e).

In accordance with 10 CFR 50.48, all changes in the facility are maintained until the termination of the license. Records of superseded procedures are maintained for a period of 3 years from the date the record was superseded.

Comanche Peak Nuclear Power Plant, Units 3 & 4
COL Application
Part 2, FSAR

9.5.1.6.4.1 Fire Fighting Procedures

Fire fighting procedures cover such items as notification of a fire, fire emergency procedures, and coordination of fire fighting activities with local fire departments. The procedures identify the following:

- Actions required of the individual discovering the fire, such as notification to the control room, an attempt to extinguish the fire, and the activation of local fire suppression systems
- Actions required of the control room personnel, such as sounding fire alarms and notifying the shift manager/fire brigade leader of the type, size, and the location of the fire
- Actions required of the fire brigade after notification of a fire, including the location to assemble, directions given by the fire brigade leader, and the responsibilities of the brigade members such as the selection of fire fighting and protective equipment and the use of pre-planned strategies for fighting fires in specific areas
- Actions required of the plant management and security after the notification of fire
- Actions that coordinate fire fighting activities with offsite fire departments including the identification of the person responsible for assessing the situation and calling in the local fire department's assistance, if deemed necessary
- Actions necessary to accommodate the response from an offsite fire department assuring appropriate contact with the CPNPP 3 and 4 incident commander, emergency personnel, and the fire brigade
- The strategies established for fighting fires in safety-related areas and areas presenting a hazard to safety-related equipment; strategies such as the identification of combustibles in each plant zone covered by a fire fighting procedure, the type of fire extinguishers best suited for controlling the fires with the combustible loadings of the zone, and instructions for plant operators and general plant personnel during a fire

9.5.1.6.4.2 Administrative Procedures and Controls

Administrative procedures and controls ensure the reliable performance of fire protection personnel, systems and equipment. Effective measures are in place to control the use and storage of combustibles and control ignition sources. Administrative controls also include procedures for performing and maintaining periodic housekeeping inspections to ensure continued compliance with fire protection controls.

9.5.1.6.4.2.1 Design Control Procedures

Design control procedures are in place to ensure that changes to the plant receive a documented evaluation that concludes no adverse impact to the fire protection

Comanche Peak Nuclear Power Plant, Units 3 & 4
COL Application
Part 2, FSAR

program. The evaluation includes the effect of the design change on the fire hazards analysis and considers whether SSCs for a success path for safe shutdown are affected or a new element is introduced in the area. For evaluations which conclude that there is no adverse affect, the evaluations are retained and are available for future inspection and reference.

If a proposed change alters compliance with a rule, then an exemption from the rule is required in accordance with 10 CFR 50.12. If a proposed change alters a license condition or Technical Specification that was used to satisfy NRC requirements, the licensee will submit a license amendment request. If neither an amendment to the license nor an exemption to the rule is requested for changes that adversely impact the FPP, then modifications to achieve conformance are provided.

In the case of a degraded or nonconforming condition, an evaluation may depend on compensatory and corrective actions. Three potential conditions exist for determining the need for an evaluation. These conditions are: (1) the use of interim compensatory actions, (2) corrective actions that result in a change, or (3) corrective actions that restore the nonconforming or degraded condition to the previous condition.

Temporary changes to specific fire protection features may be necessary to accomplish maintenance or modifications. These changes are acceptable, provided interim compensatory measures such as fire watches, temporary fire barriers, or backup suppression capability exist. For common types of deficiencies, the technical requirements manual and/or the CPNPP program note select specific compensatory measures. For unique situations or for measures that the program does not address, the CPNPP fire protection staff determines appropriate compensatory measures in accordance with the licensing basis.

Where the evaluation of a program change considers the results from fire modeling, documentation is developed that demonstrates the fire models and methods used meet NRC requirements, are used within their limitations, and with the rigor required by the nature and scope of the analyses. These analyses may use simple hand calculations or more complex computer models, depending on the specific conditions of the scenario under consideration. If prior NRC review and approval of certain Appendix R requirements is not sought, a fire protection engineer (assisted by others as needed) performs an Appendix R equivalency evaluation, which is retained for a future NRC inspection. These equivalency evaluations are written and organized to facilitate review by a person not involved in the evaluation. The equivalency evaluation includes all supporting calculations and clearly states all assumptions at the outset. The fire protection program includes fire risk evaluations to identify potential exposure fires to safety related SSCs. A fire protection engineer (assisted by others as needed) performs an assessment of SSCs installed in close proximity to potential fire hazards such as flammable liquid and gas storage facilities. The fire protection engineer consults with the appropriate codes and standards to ensure that such installations are minimized and, for such installations, appropriate protective measures are provided.

Comanche Peak Nuclear Power Plant, Units 3 & 4
COL Application
Part 2, FSAR

9.5.1.6.4.2.2 Safe Shutdown Procedures

Procedures for effecting safe-shutdown for CPNPP use two normal safety trains of equipment, which allows safe plant shutdown without further degradation of plant safety functions should a fire occur in one of the four separate safety train areas. Time-critical operations for effecting safe-shutdown are identified in the safe-shutdown analysis and incorporated in post-fire procedures. These time governed steps were validated prior to procedural incorporation. Procedures govern the tasks to implement remote shutdown capability when offsite power is available and when offsite power is not available for 72 hours. These procedures also address necessary actions to compensate for spurious operations and high-impedance faults if such actions are required. Fire events and fire protection deficiencies that meet the criteria of 10 CFR 50.72 and 10 CFR 50.73 will be reported to the NRC as appropriate in accordance with the requirements of these regulations and the guidelines provided in NUREG 1022.

9.5.1.6.4.2.3 Low Power and Non-Power Procedures

Low power and non-power operating procedures serve to minimize the potential for fire events to affect safety functions during shutdown operations (i.e., maintenance or refueling outages) when fire risk may increase significantly because of work activities. The procedures assure sufficient redundancy. They also assure that critical safety functions (e.g., reactivity control, reactor decay heat removal, and spent fuel pool cooling) are shielded from potential adverse impact of a fire that could result in the unacceptable release of radioactive materials, under the differing conditions that may be present during shutdown operations.

9.5.1.6.4.2.4 Control of Combustibles

Effective administrative controls minimize the amount of combustibles that safety-related areas are exposed to during operation or maintenance periods. These controls are patterned after the recommendations in NFPA 804 and govern the following.

- Proper control of flammable and combustible liquids and gases throughout the plant including safety-related areas. The handling, use and storage of flammable and combustible liquids complies with the provisions of NFPA 30. The amounts of these materials are controlled and the materials are handled using approved containers. The storage, use and handling of compressed gases comply with the provisions of NFPA-55.
- Proper control of combustible materials such as HEPA and charcoal filters, dry ion exchange resins or other combustible materials used in safety-related areas. Such materials will be allowed in safety-related areas only in amounts which will be used immediately.
- Restrict the storage of unused ion exchange resin and hazardous materials in safety-related areas.

Comanche Peak Nuclear Power Plant, Units 3 & 4
COL Application
Part 2, FSAR

- Transient fire loads during maintenance and modifications such as combustibles and flammable liquids, wood, and plastic materials in buildings containing safety-related systems or equipment. Only fire retardant wood is allowed within safety-related areas and this is on a case-by-case basis. This control requires an in-plant review of work activities to identify transient fire loads. The supervisor or foreman responsible for reviewing the work activity will specify any required additional fire protection consulting the fire protection engineer as required.
- The fire protection program includes fire prevention element reviews of proposed plant modifications. A fire protection engineer (assisted by others as necessary) reviews proposed plant modifications to ensure the following: fixed fire loads are not adversely increased beyond that accounted for in the fire hazards analysis, suitable fire protection is provided in the affected area, and the fire hazards analysis is updated accordingly.
- Waste, debris, scrap, and oil spills resulting from work activities in safety-related areas are minimized while work is in progress and removed at the end of each shift or upon completion of an activity, whichever is shorter.
- Periodic housekeeping inspection for accumulation of combustibles is performed to assure that procedural controls in place are effective.

All interior temporary structures will be constructed of noncombustible, limited-combustible, or fire-retardant pressure-impregnated wood. Structures constructed of noncombustible or limited-combustible materials will be protected by an automatic fire suppression system unless a fire hazard analysis determines that automatic suppression is not required. Structures constructed of fire-retardant pressure-impregnated wood are protected by an automatic fire suppression system. The use of interior temporary coverings is limited to special conditions where interior temporary coverings are necessary and constructed of approved fire-retardant tarpaulins. Where framing is required, it is constructed of noncombustible, limited-combustible, or fire-retardant pressure-impregnated wood. All interior temporary facilities have the appropriate type and size of portable fire extinguisher.

9.5.1.6.4.2.5 Control of Ignition Sources

Effective procedural controls exist to protect plant equipment from fire damage or loss resulting from work activities involving ignition sources. A hot works program is integrated in installation, modification, maintenance and operational procedures to ensure control of ignition sources during various plant activities. These procedural controls prohibit the use of open flame or combustion smoke for leak testing and minimize unnecessary ignition sources in critical plant areas. Smoking is also prohibited in safety-related areas of the plant. The company smoking policy identifies where smoking is allowed.

Comanche Peak Nuclear Power Plant, Units 3 & 4
COL Application
Part 2, FSAR

Established procedural controls ensure that the following precautions are taken:

- Hot work activities including open flame, welding, cutting, or grinding is authorized by the responsible foreman or supervisor through a hot work permit. The hot work permit identifies the fire hazards in the immediate work area and the fire prevention methods to be used during the hot work activities. The fire prevention methods may include protecting surrounding equipment with fire retardant covering and providing a portable fire extinguisher of appropriate class and size dedicated for the specific hot work activity.
- The responsible foreman, supervisor or worker receives sufficient fire fighting and fire prevention training for the anticipated fires to be considered qualified as a fire watch for hot work activities. See Subsection 9.5.1.6.1.9 for more information on fire watches.
- Prior to any hot work performed on or near plant equipment, the responsible foreman or supervisor ensures that the hot work permit is posted at the work area and that all required fire prevention methods identified on the hot work permit are in place. The responsible foreman, supervisor assigns a qualified individual as a fire watch to the hot work permit.
- Upon completion of the hot works activities, the assigned fire watch will remain at the work location for a period of time to ensure that all hot works are completed and the risk of fire from the hot work activity is removed.

9.5.1.6.4.2.6 Fire Protection Rounds

A fire prevention surveillance plan integrated with recorded rounds to all accessible sections of the plant is performed periodically. Inspections of the plant are conducted in accordance with NFPA 601, "Standard for Security Services in Fire Loss Prevention" (Reference 9.5.1-201). A proceduralized checklist is used for the inspection and retained as documentation for a period of 2 years. Areas of primary containment and high-radiation areas normally inaccessible during plant operation are inspected as plant conditions permit but at least during each refueling outage. For any plant areas inaccessible for periods greater than 2 years, the most recent inspection is retained.

9.5.1.6.4.2.7 Fire Protection Preventative Maintenance

Fire protection preventative maintenance procedures are provided to perform periodic maintenance on fire protection equipment such as the fire pumps and drivers as recommended by the manufacturers of the equipment. Additionally, procedures are provided to address periodic inspection of fire doors, fire dampers, penetration seals and fire barrier wraps.

**Comanche Peak Nuclear Power Plant, Units 3 & 4
COL Application
Part 2, FSAR**

9.5.1.6.4.2.8 Fire Protection System Maintenance and Impairments

The fire protection program provides procedural control for the periodic inspection, testing, and maintenance of fire protection SSCs. The testing and maintenance of fire protection SSCs are performed by qualified personnel. Applicable codes, standards and manufacturer's recommendations provide the basis for the testing, and maintenance procedures. Additionally, the fire protection program provides periodic inspection procedures for fire barriers, fire doors, fire dampers and fire barrier penetration seals. Identified impairments to fire protection features, such as fire barriers and associated features, fire detection and fire suppression systems, fire pumps, fire detection and suppression systems, are also procedurally controlled where an impairment permit is generated, corrective actions are initiated and appropriate compensatory measures are established until the impairment is corrected.

9.5.1.6.5 Fire Protection Quality Assurance Program

The QA program for fire protection is prepared and implemented under QA program reference in [Chapter 17](#), and the "Comanche Peak Nuclear Power Plant Units 3 and 4 Quality Assurance Program Description," (which is described in [FSAR Section 17.5](#)) Part III Sections 1 and 2.

9.5.2 Communication Systems

CP COL 9.5(4) Replace the first sentence of the second paragraph in [DCD Subsection 9.5.2](#) with the following.

The intra-plant communications systems consist of a public address/page party line system, intra-plant telephone system, intra-plant sound powered telephone system, plant radio transmitter and receiver system, broadband (internet) communications, and offsite radio systems. The offsite communications systems include telephone, radio frequency system, privately-owned microwave and fiber optic systems, broadband (internet), and personal cell phone.

9.5.2.2.2 Private Automatic Branch Telephone Exchange (PABX)

CP COL 9.5(4) Replace the third sentence in [DCD Subsection 9.5.2.2.2](#) with the following.

CP COL 9.5(5)

Access to commercial facilities such as central office trunk, utility's private network, and other offsite connections are provided through redundant and diverse routes as discussed in [Subsection 9.5.2.2.2.2](#) and [9.5.2.2.5.1](#).

**Comanche Peak Nuclear Power Plant, Units 3 & 4
COL Application
Part 2, FSAR**

9.5.2.2.2.2 Emergency Telephones

CP COL 9.5(4)
CP COL 9.5(5)

Add the following paragraphs to the end of the **DCD Subsection 9.5.2.2.2.2**.

Direct communications links (direct telephone) are provided to the NRC Operations Center, the State Emergency Operations Center, and the Central Emergency Operations Center. A crisis management radio system is provided which meets the intent of NUREG 0654 is discussed in **Subsection 9.5.2.2.5.2**.

In emergency offsite communication, as the emergency notification system is connected through a local telephone company system, then a station package is required. The station package is designed, installed, and maintained at the site. The design provides a functional emergency notification system from the site to NRC Operations Center in the event of a LOOP at the site and is in compliance with the requirement of IE Bulletin 80-15.

9.5.2.2.5.1 General

CP COL 9.5(4)

Replace the first and second sentence of the first paragraph in **DCD Subsection 9.5.2.2.5.1** with the following.

Plant specific redundant external communication links include.

- Copper and fiber optic telephone circuits
 - Microwave telephone links
 - Fiber optic data links
 - Emergency radio communication links
 - Direct telephone links to utility operations centers, the NRC, and State and Local Emergency Operations facilities
 - Personal cell phone links (no credit is taken but these links provide alternate links which allow for additional communication paths)
-

9.5.2.2.5.2 Emergency Communications

CP COL 9.5(6)
CP COL 9.5(7)
CP COL 9.5(8)
CP COL 9.5(9)

Replace the second and third sentence of the second paragraph in **DCD Subsection 9.5.2.2.5.2** with the following.

Comanche Peak Nuclear Power Plant, Units 3 & 4
COL Application
Part 2, FSAR

The effectiveness of the overall emergency response plan is in conformance with the requirements of 10 CFR 50.47 (b)(8). Adequate communications equipment are provided and maintained to allow the control room to communicate with offsite personnel and organizations. Pursuant to the emergency response plan, the following equipment is tested.

- An inspection and test is performed of the TSC voice communication equipment.
- An inspection and test is performed of the operation support center voice communication equipment.
- An inspection and test is performed of the EOF voice communication equipment.
- A test is performed of the means for warning or advising onsite individuals of an emergency.

A continuously manned alarm station as required by 10 CFR 73.46(e)(5) is provided.

Communication subsystems are provided as required by 10 CFR 73.46(e)(5). Each guard, watchman, or armed responder on duty maintains continuous communication with each continuously manned alarm station. The individual in the alarm station is capable of calling for assistance from other guards, watchmen, armed responders, and from law enforcement authorities.

Communication network and equipments for rapid and accurate transmission of routine security information to onsite personnel are provided for assessment of a contingency and response to a contingency and for rapid transmission of information to offsite assessment team. This is in conformance to the requirements of 10 CFR 73.45(g)(4)(i) and (ii).

Each alarm station required by 10 CFR 73.46 (e)(5) of the regulation has both conventional telephone service and radio or microwave transmitted two-way voice communication, either directly or through an intermediary, for the capability of communication with the law enforcement authorities.

The offsite communications systems within the onsite Technical Support Center and operations support center provide for emergency response following a design basis accident. During emergencies, the TSC is the primary onsite communication center for the communications to the control room, the operations support center and the NRC.

In addition, provisions for communication with state and local operations centers are provided in the onsite TSC to initiate early notification and recommendations to offsite authorities prior to activation of the EOF. This is in accordance with the requirements of 10 CFR 50 Appendix E, Part IV.E.9.

**Comanche Peak Nuclear Power Plant, Units 3 & 4
COL Application
Part 2, FSAR**

CP COL 9.5(5) Replace sixth paragraph in **DCD Subsection 9.5.2.2.5.2** with the following.
CP COL 9.5(6)
CP COL 9.5(9)

The emergency offsite communication system serves as an alternate means of communication to notify local authorities of an emergency at the nuclear plant. Radios are provided for communications with the main control room, TSC, EOF, and local authorities.

This emergency radio communications system connects onsite and offsite monitoring teams with the operation support center and EOF respectively.

The plant is provided with separate telephone systems for operations and for security pursuant to 10 CFR 73.55(f). Data Communications is discussed in Section 7.9. Fire brigade communications is covered in **Subsection 9.5.1**.

The CPNPP emergency plan and security plan are described in Sections 13.3 and 13.6, respectively. These plans require testing of offsite communications links.

9.5.2.3 Safety Evaluation

CP COL 9.5(7) Add the following paragraph after the first paragraph in **DCD Subsection 9.5.2.3**.

Plant specific safety evaluations and procedures are established by the plant operator to prevent any unauthorized access to secure locations and or unconfirmed removal of strategic special nuclear material in accordance with 10 CFR 73.45(e)(2)(iii).

9.5.4.3 Safety Evaluation

CP COL 9.5(11) Replace the second sentence of the seventh paragraph in **DCD Subsection 9.5.4.3** with the following.

Fuel oil is normally brought in by tank truck for recharging the storage tank. Additionally, if circumstances require, railroad tank cars can be brought in on the site railroad spur. The CPNPP Units 3 and 4 are located approximately 90 miles southwest of the Dallas - Ft. Worth area. Dallas - Ft. Worth is a major commercial area which has distributors of diesel fuel that represent the majority of the major oil companies. The cities, such as Houston, Beaumont etc, within 300 miles from site are capable of supplying diesel fuel oil within seven days.

**Comanche Peak Nuclear Power Plant, Units 3 & 4
COL Application
Part 2, FSAR**

9.5.9 Combined License Information

Replace the content of **DCD Subsection 9.5.9** with the following.

CP COL 9.5(1) **9.5(1)** *Fire protection program, fire fighting procedures, and quality assurance*

This COL item is addressed in **Subsections 9.5.1, 9.5.1.3, 9.5.1.6, Table 9.5.1-1R | and Table 9.5.1-2R.**

CP COL 9.5(2) **9.5(2)** *Site specific fire protection aspects*

This COL item is addressed in **Subsection 9.2.1.2.1, 9.5.1.2.1, 9.5.1.2.2, 9.5.1.2.3, 9.5.1.2.4, Table 9.5.1-1R, Table 9.5.1-2R, Figure 9.5.1-201, Figure 9.5.1-202 and Appendix 9A.**

CP COL 9.5(3) **9.5(3)** *Apparatus for plant personnel and fire brigades*

This COL item is addressed in **Subsection 9.5.1.6.1.8 and Table 9.5.1-2R.**

CP COL 9.5(4) **9.5(4)** *Communication system interfaces external to the plant (offsite locations)*

This COL item is addressed in **Subsection 9.5.2, 9.5.2.2.2, 9.5.2.2.2.2 and 9.5.2.2.5.1.**

CP COL 9.5(5) **9.5(5)** *The emergency offsite communications*

This COL item is addressed in **Subsection 9.5.2.2.2, 9.5.2.2.2.2 and 9.5.2.2.5.2.**

CP COL 9.5(6) **9.5(6)** *Connections to the Technical Support Center*

This COL item is addressed in **Subsection 9.5.2.2.5.2**

CP COL 9.5(7) **9.5(7)** *Continuously manned alarm station*

This COL item is addressed in **Subsection 9.5.2.2.5.2. and 9.5.2.3.**

CP COL 9.5(8) **9.5(8)** *Offsite communications for the onsite operations support center.*

This COL item is addressed in **Subsection 9.5.2.2.5.2**

CP COL 9.5(9) **9.5(9)** *Emergency communication system*

This COL item is addressed in **Subsection 9.5.2.2.5.2.**

9.5(10) Deleted from the DCD.

CP COL 9.5(11) **9.5(11)** *Fuel oil recharging* |

**Comanche Peak Nuclear Power Plant, Units 3 & 4
COL Application
Part 2, FSAR**

*This COL item is addressed in **Subsection 9.5.4.3**.*

CP COL 9.5(2) **9.5.10 References**

Add the following references after the last reference in **DCD Subsection 9.5.10**.

- 9.5.1-201 NFPA 601, *Standard for Security Services in Fire Loss Prevention*, 2005 Edition, National Fire Protection Association, Quincy, MA.
- 9.5.1-202 NFPA 1971, *Standard on Protective Ensembles for Structural Fire Fighting and Proximity Fire Fighting*, 2007 Edition, National Fire Protection Association, Quincy, MA.
- 9.5.1-203 NFPA 1981, *Standard on Open-Circuit Self-Contained Breathing Apparatus (SCBA) for Emergency Services*, 2007 Edition, National Fire Protection Association, Quincy, MA.
- 9.5.1-204 NFPA 1982, *Standard on Personal Alert Safety Systems (PASS)*, 2007 Edition, National Fire Protection Association, Quincy, MA.
- 9.5.1-205 NFPA 1561, *Standard on Emergency Services Incident management System*, 2005 Edition, National Fire Protection Association, Quincy, MA.
- 9.5.1-206 IEEE Std 980-1994, *IEEE Guide for Containment and Control of Oil Spills in Substations*, Institute of Electrical and Electronics Engineers, New York, NY.
- 9.5.1-207 NFPA 30, *Flamable and Combustible Liquids Code*, 2008 Edition, National Fire Protection Association, Quincy, MA.
- 9.5.1-208 NFPA 22, *Standard for Water Tanks for Private Fire Protection*, 2008 Edition, National Fire Protection Association, Quincy, MA.
- 9.5.1-209 NFPA 10, *Standard for Portable Fire Extinguishers*, 2007 Edition, National Fire Protection Association, Quincy, MA.
- 9.5.1-210 NUREG 1022, *Event Reporting Guidelines 10 CFR 50.72 and 50.73, Rev. 2*.

**Comanche Peak Nuclear Power Plant, Units 3 & 4
COL Application
Part 2, FSAR**

**Table 9.5.1-1R (Sheet 1 of 51)
CPNPP Units 3 & 4 Fire Protection Program Conformance with RG 1.189**

Regulatory Position	Position Number	Conformance	Remarks	
CP COL 9.5(1)	In accordance with 10 CFR 50.48, each operating nuclear power plant must have a fire protection plan. The plan should establish the fire protection policy for the protection of SSCs important to safety at each plant and the procedures, equipment, and personnel required to implement the program at the plant site.	1.	Conform	See Subsection 9.5.1.6.
CP COL 9.5(1)	The fire protection program should describe the organizational structure and responsibilities for its establishment and implementation. These responsibilities include fire protection program policy; program management (including program development, maintenance, updating, and compliance verification), fire protection staffing and qualifications; engineering and modification, inspection, testing, and maintenance of FPSs, features, and equipment, fire prevention, emergency response (e.g., fire brigades and offsite mutual aid), and general employee, operator, and fire brigade training.	1.1	Conform	See Subsection 9.5.1.6.
CP COL 9.5(2)	A fire hazards analysis should be performed to demonstrate that the plant will maintain the ability to perform safe-shutdown functions and minimize radioactive material releases to the environment in the event of a fire. This analysis should be revised as necessary to reflect plant design and operational changes.	1.2	Conform	FHA is included as Appendix 9A
	In accordance with 10 CFR 50.48, each operating nuclear power plant must provide the means to limit fire damage to SSCs important to safety so that the capability to safely shut down the reactor is ensured.	1.3	Conform	4 safety trains are provided which are completely separated by 3-hour fire rated barriers. Any two trains can achieve safe-shutdown.
	The licensee should evaluate fire reports and data (e.g., fire barrier testing results and cable derating data) that are used to demonstrate compliance with NRC fire protection requirements to ensure	1.4	Conform	The US-APWR employs the use of limited applications of cable fire barriers, which have been qualified in
	that the information is applicable and representative of the conditions for which the information is being applied.			accordance with GL 86-10 supplement 1.

**Comanche Peak Nuclear Power Plant, Units 3 & 4
COL Application
Part 2, FSAR**

**Table 9.5.1-1R (Sheet 2 of 51)
CPNPP Units 3 & 4 Fire Protection Program Conformance with RG 1.189**

	Regulatory Position	Position Number	Conformance	Remarks
CP COL 9.5(1)	Temporary changes to specific fire protection features that may be necessary to accomplish maintenance or modifications are acceptable, provided interim compensatory measures, such as fire watches, temporary fire barriers, or backup suppression capability, are implemented. For common types of deficiencies, the technical specifications or the NRC-approved fire protection program generally note the specific compensatory measures. For unique situations or for measures that the approved fire protection program does not include, the licensee may determine appropriate compensatory measures. A licensee may opt to implement an alternative compensatory measure, or combination of measures, to the one stated in its fire protection program.	1.5	Conform	See Subsection 9.5.1.6.
CP COL 9.5(1)	The fire protection program should be under the direction of an individual who has available staff personnel knowledgeable in both fire protection and nuclear safety. Plant personnel should be adequately trained in the administrative procedures that implement the fire protection program and the emergency procedures relative to fire protection.	1.6	Conform	See Subsection 9.5.1.6.
CP COL 9.5(1)	Fire protection staff should meet the following qualifications: a. The formulation and assurance of the fire protection program and its implementation should be the responsibility of personnel prepared by training and experience in fire protection and in nuclear plant safety to provide a comprehensive approach in directing the fire protection program for the nuclear power	1.6.1.a	Conform	See Subsection 9.5.1.6.
	plant. A fire protection engineer (or a consultant) who is a graduate of an engineering curriculum of accepted standing and satisfies the eligibility requirements as a Member in the Society of Fire Protection Engineers should be a member of the organization responsible for the formulation and implementation of the fire protection program.			

**Comanche Peak Nuclear Power Plant, Units 3 & 4
COL Application
Part 2, FSAR**

**Table 9.5.1-1R (Sheet 3 of 51)
CPNPP Units 3 & 4 Fire Protection Program Conformance with RG 1.189**

	Regulatory Position	Position Number	Conformance	Remarks
CP COL 9.5(1)	b. The fire brigade members' qualifications should include satisfactory completion of a physical examination for performing strenuous activity and the fire brigade training as described in Regulatory Position 1.6.4.	1.6.1.b	Conform	See Subsection 9.5.1.6.
CP COL 9.5(1)	c. The personnel responsible for the maintenance and testing of the fire protection systems should be qualified by training and experience for such work.	1.6.1.c	Conform	See Subsection 9.5.1.6.
CP COL 9.5(1)	d. The personnel responsible for the training of the fire brigade should be qualified by knowledge, suitable training, and experience for such work.	1.6.1.d	Conform	See Subsection 9.5.1.6.
CP COL 9.5(1)	Each nuclear plant employee has a responsibility to prevent, detect, and suppress fires. General site employee training should introduce all personnel to the elements of the site's fire protection program, including the responsibilities of the fire protection staff. Training should also include information on the types of fires and related extinguishing agents, specific fire hazards at the site, and actions in the event of a fire suppression system actuation.	1.6.2	Conform	See Subsection 9.5.1.6.
CP COL 9.5(1)	Fire watches provide for observation and control of fire hazards associated with hot work, and they may act as compensatory measures for degraded fire protection systems and features. Specific fire watch training should	1.6.3	Conform	See Subsection 9.5.1.6.
	provide instruction on fire watch duties, responsibilities, and required actions for both 1-hour roving and continuous fire watches. Fire watch qualifications should include hands-on training on a practice fire with the extinguishing equipment to be used while on fire watch. If fire watches are to be used as compensatory actions, the fire watch training should include recordkeeping requirements.			

**Comanche Peak Nuclear Power Plant, Units 3 & 4
COL Application
Part 2, FSAR**

**Table 9.5.1-1R (Sheet 4 of 51)
CPNPP Units 3 & 4 Fire Protection Program Conformance with RG 1.189**

	Regulatory Position	Position Number	Conformance	Remarks
CP COL 9.5(1)	The fire brigade training program should establish and maintain the capability to fight credible and challenging fires. The program should consist of initial classroom instruction followed by periodic classroom instruction, firefighting practice, and fire drills. (See Regulatory Position 3.5.1.4 for drill guidance.)	1.6.4	Conform	See Subsection 9.5.1.6.
CP COL 9.5(1)	The brigade leader and at least two brigade members should have sufficient training in or knowledge of plant systems to understand the effects of fire and fire suppressants on safe-shutdown capability. The brigade leader should be competent to assess the potential safety consequences of a fire and advise MCR personnel. Such competence by the brigade leader may be evidenced by possession of an operator's license or equivalent knowledge of plant systems. Nuclear power plants staffed with a dedicated professional fire department may utilize a fire team advisor to assess the potential safety consequences of a fire and advise the MCR and incident commander. The fire team advisor should possess an operator's license or equivalent knowledge of plant systems and be dedicated to supporting the fire incident commander during fire emergency events.	1.6.4.1	Conform	See Subsection 9.5.1.6.
CP COL 9.5(1)	Instruction should be provided by qualified individuals who are knowledgeable, experienced, and suitably trained in fighting the types of fires that could occur in the plant and in using the types of equipment available in the nuclear power plant. The licensee should provide instruction to all fire brigade members and fire brigade leaders.	1.6.4.2	Conform	See Subsection 9.5.1.6.

**Comanche Peak Nuclear Power Plant, Units 3 & 4
COL Application
Part 2, FSAR**

**Table 9.5.1-1R (Sheet 5 of 51)
CPNPP Units 3 & 4 Fire Protection Program Conformance with RG 1.189**

Regulatory Position	Position Number	Conformance	Remarks	
CP COL 9.5(1)	The licensee should hold practice sessions for each shift fire brigade on the proper method of fighting the various types of fires that could occur in a nuclear power plant. These sessions should provide brigade members with experience in actual fire extinguishment and the use of self-contained breathing apparatuses under the strenuous conditions encountered in firefighting. The licensee should provide these practice sessions at least once per year for each fire brigade member.	1.6.4.3	Conform	See Subsection 9.5.1.6.
CO COL 9.5(1)	The licensee should maintain individual records of training provided to each fire brigade member, including drill critiques, for at least 3 years to ensure that each member receives training in all parts of the training program. These records of training should be available for NRC review.	1.6.4.4	Conform	See Subsection 9.5.1.6.
CP COL 9.5(1)	The overall plant QA plan should include the QA program for fire protection. For fire protection systems, the licensee should have and maintain a QA program that provides assurance that the fire protection systems are designed, fabricated, erected, tested, maintained, and operated so that they will function as intended. Fire protection systems are not "safety-related" and, therefore, are not within the scope of Appendix B, "Quality Assurance Criteria for Nuclear Power Plants and Fuel Reprocessing Plants," to 10 CFR 50, unless the licensee has committed to include these systems under the plant's Appendix B program.	1.7	Conform	See Subsection 9.5.1.6.
CP COL 9.5(1)	The licensee should establish measures to include the guidance presented in this RG in its design and procurement documents.	1.7.1	Conform	See Subsection 9.5.1.6.
CP COL 9.5(1)	Documented instructions, procedures, or drawings should prescribe inspections, tests, administrative controls, fire drills, and training that govern the fire protection program.	1.7.2	Conform	See Subsection 9.5.1.6.

**Comanche Peak Nuclear Power Plant, Units 3 & 4
COL Application
Part 2, FSAR**

**Table 9.5.1-1R (Sheet 6 of 51)
CPNPP Units 3 & 4 Fire Protection Program Conformance with RG 1.189**

Regulatory Position	Position Number	Conformance	Remarks	
CP COL 9.5(1)	The licensee should establish the following measures to ensure that purchased material, equipment, and services conform to the procurement documents: a. provisions, as appropriate, for source evaluation and selection, objective evidence of quality furnished by the contractor, inspections at suppliers, or receipt inspections b. source or receipt inspection, at a minimum, for those items that, once installed, cannot have their quality verified.	1.7.3	Conform	See Subsection 9.5.1.6.
CP COL 9.5(1)	The licensee should establish and execute a program for independent inspection of activities affecting fire protection that allows the organization performing the activity to verify conformance to documented installation drawings and test procedures.	1.7.4	Conform	See Subsection 9.5.1.6.
CP COL 9.5(1)	The licensee should establish and implement a test program to ensure that testing is performed and verified by inspection and audit to demonstrate conformance with design and system readiness requirements. The tests should be performed in accordance with written test procedures; test results should be properly evaluated and corrective actions taken as necessary.	1.7.5	Conform	See Subsection 9.5.1.6.
CP COL 9.5(1)	The licensee should establish measures to provide for the documentation or identification of items that have satisfactorily passed required tests and inspections. These measures should include provisions for identification by means of tags, labels, or similar temporary markings to indicate completion of required inspections and tests and operating status.	1.7.6	Conform	See Subsection 9.5.1.6.
CP COL 9.5(1)	The licensee should establish measures to control items that do not conform to specified requirements to prevent inadvertent use or installation.	1.7.7	Conform	See Subsection 9.5.1.6.

**Comanche Peak Nuclear Power Plant, Units 3 & 4
COL Application
Part 2, FSAR**

**Table 9.5.1-1R (Sheet 7 of 51)
CPNPP Units 3 & 4 Fire Protection Program Conformance with RG 1.189**

Regulatory Position	Position Number	Conformance	Remarks	
CP COL 9.5(1)	The licensee should establish measures to ensure that conditions adverse to fire protection, such as failures, malfunctions, deficiencies, deviations, defective components, uncontrolled combustible materials, and nonconformances, are promptly identified, reported, and corrected.	1.7.8	Conform	See Subsection 9.5.1.6.
CP COL 9.5(1)	The licensee should prepare and maintain records to furnish evidence that the plant is meeting the criteria enumerated above for activities affecting the fire protection program.	1.7.9	Conform	See Subsection 9.5.1.6.
CP COL 9.5(1)	The licensee should conduct and document audits to verify compliance with the fire protection program.	1.7.10	Conform	See Subsection 9.5.1.6.
CP COL 9.5(2)	For those licensees who have relocated audit requirements from their technical specifications to the QA program, annual fire protection audits may be changed to a "maximum interval of 24 months" by implementation of a performance-based schedule, if justified by performance reviews, provided that the maximum audit interval does not exceed the interval specified in American National Standards Institute/American Nuclear Society (ANSI/ANS) 3.2-1994, "Administrative Controls and Quality Assurance for the Operational Phase of Nuclear Power Plants."	1.7.10.1	Conform	See Subsection 9.5.1.6.
CP COL 9.5(1)	The 24-month audit of the fire protection program and implementing procedures should ensure that the requirements for design, procurement, fabrication, installation, testing, maintenance, and administrative controls for the respective programs are included in the plant QA program for fire protection and meet the criteria of the QA/QC program established by the licensee, consistent with this guide. Personnel from the licensee's QA organization, who do not have direct responsibility for the program being evaluated, should perform these audits.	1.7.10.2	Conform	See Subsection 9.5.1.6.

**Comanche Peak Nuclear Power Plant, Units 3 & 4
COL Application
Part 2, FSAR**

**Table 9.5.1-1R (Sheet 8 of 51)
CPNPP Units 3 & 4 Fire Protection Program Conformance with RG 1.189**

Regulatory Position	Position Number	Conformance	Remarks
CP COL 9.5(1) The triennial audit is basically the same as the annual audit; the difference lies in the source of the auditors. Qualified utility personnel who are not directly responsible for the site fire protection program or an outside independent fire protection consultant may perform the annual audit. However, an outside independent fire protection consultant should perform the triennial audit. These audits would normally encompass an evaluation of existing documents (other than those addressed under the 24-month audit) and an inspection of fire protection system operability, inspection of the integrity of fire barriers, and witnessing the performance of procedures to verify that the licensee has fully implemented the fire protection program and that the plan is adequate for the objects protected.	1.7.10.3	Conform	See Subsection 9.5.1.6.
This section provides guidance relative to the regulatory mechanisms for addressing changes, deviations, exemptions, and other issues affecting compliance with fire protection regulatory requirements. Risk-informed, performance-based methodologies may be used to evaluate the acceptability of fire protection program changes; however, the licensee should use NRC reviewed and approved methodologies and acceptance criteria for this approach.	1.8	Information Statement	No compliance action, this is an informational statement.
If an existing plant licensee has adopted the standard license condition for fire protection and incorporated the fire protection program in the final safety analysis report (FSAR), the licensee may make changes to the approved fire protection program without the Commission's prior approval only if those changes would not adversely affect the ability to achieve and maintain safe shutdown in the event of a fire as documented in a safety evaluation.	1.8.1	N/A	The US-APWR is a new plant that will be subject to current licensing requirements of the US NRC at the time of COL application.

**Comanche Peak Nuclear Power Plant, Units 3 & 4
COL Application
Part 2, FSAR**

**Table 9.5.1-1R (Sheet 9 of 51)
CPNPP Units 3 & 4 Fire Protection Program Conformance with RG 1.189**

Regulatory Position	Position Number	Conformance	Remarks
	1.8.1.1	N/A	The US-APWR is a new plant that will be licensed under current regulations at the time of COL application.
	1.8.1.2	Information Statement	No compliance applicable, informational statement.
CP COL 9.5(1)	1.8.1.3	Conform	See Subsection 9.5.1.6.
			<p>If the fire protection program committed to by the licensee is required by a specific license condition and is not part of the FSAR for the facility, the licensee may be required to submit amendment requests even for relatively minor changes to the fire protection program.</p> <p>The NRC transmitted the standard license condition for fire protection to licensees in April 1986 as part of GL 86-10 with information on its applicability to specific plants.</p> <p>If a proposed change alters compliance with a rule then an exemption from the rule is required in accordance with 10 CFR 50.12. If a proposed change alters a license condition or technical specification that was used to satisfy NRC requirements, the licensee should submit a license amendment request.</p> <p>When a change that falls within the scope of the changes allowed under the standard fire protection license condition is planned, the licensee's evaluation should be made in conformance with the standard fire protection license condition to determine whether the change would adversely affect the ability to achieve and maintain safe shutdown.</p>
CP COL 9.5(1)	1.8.1.4	Conform	See Subsection 9.5.1.6.
			<p>In addition to an evaluation of planned changes, an evaluation may also be required for nonconforming conditions. In the case of a degraded or nonconforming condition, an evaluation depends on the licensee's compensatory and corrective actions. Three potential conditions exist for determining the need for an evaluation. These conditions are (1) the use of interim compensatory actions, (2) corrective actions that result in a change, or (3) corrective actions that restore the nonconforming or degraded condition to the previous condition.</p>

**Comanche Peak Nuclear Power Plant, Units 3 & 4
COL Application
Part 2, FSAR**

**Table 9.5.1-1R (Sheet 10 of 51)
CPNPP Units 3 & 4 Fire Protection Program Conformance with RG 1.189**

	Regulatory Position	Position Number	Conformance	Remarks
CP COL 9.5(1)	The licensee should maintain records of fire protection program-related changes in the facility, changes in procedures, and tests and experiments made in accordance with the standard fire protection license condition. These records should include a written evaluation that provides the bases for the determination that the change does not adversely affect safe-shutdown capability.	1.8.1.5	Conform	See Subsection 9.5.1.6.
	For plants licensed before January 1, 1979, the NRC requires requests for exemption from the requirements of Appendix R for modifications or conditions that do not comply with the applicable sections of Appendix R. The exclusion of the applicability of sections of Appendix R other than Sections III.G, III.J, and III.O (and Section III.L as applicable) is limited to those features accepted by the NRC staff as satisfying the provisions of Appendix A to BTP APCS 9.5-1 reflected in staff fire protection safety evaluation reports issued before the effective date of the rule. For these previously approved features, an exemption request is not required except for proposed modifications that would alter previously approved features used to satisfy NRC requirements.	1.8.2	N/A	The US-APWR is a new plant that satisfy the requirement applicable to advanced light water reactors.
CP COL 9.5(1)	The NRC interpretations of certain Appendix R requirements allow a licensee to choose not to seek prior NRC review and approval of, for example, a fire area boundary, in which case a fire protection engineer (assisted by others as needed) should perform an evaluation, which should be retained for a future NRC audit.	1.8.3	Conform	See Subsection 9.5.1.6.

**Comanche Peak Nuclear Power Plant, Units 3 & 4
COL Application
Part 2, FSAR**

**Table 9.5.1-1R (Sheet 11 of 51)
CPNPP Units 3 & 4 Fire Protection Program Conformance with RG 1.189**

Regulatory Position	Position Number	Conformance	Remarks	
	1.8.4	Conform	The US-APWR is a new plant that does not involve unapproved deviations from regulatory requirements.	
CP COL 9.5(1)	The requirements of 10 CFR 50.72 and 10 CFR 50.73 apply to reporting certain events and conditions related to fire protection at nuclear power plants. Licensees should report fire events or fire protection deficiencies that meet the criteria of 10 CFR 50.72 and 10 CFR 50.73 to the NRC as appropriate and in accordance with the requirements of these regulations.	1.8.5	Conform	See Subsection 9.5.1.6.
CP COL 9.5(2)	For those fire protection SSCs installed to satisfy the NRC requirements and designed to NFPA codes and standards, the code of record is the code edition in force at the time of the design or at the time the commitment is made to the NRC for a fire protection feature. The FSAR or the fire hazards analysis should identify and justify deviations from the codes. Deviations should not degrade the performance of fire protection systems or features. The standards of record related to the design and installation of fire protection systems and features required to satisfy NRC requirements in all new reactor designs are those NFPA codes and standards in effect 180 days prior to the submittal of the application under 10 CFR 50 or 10 CFR 52.	1.8.6	Conform	See Subsection 9.5.1.1.

**Comanche Peak Nuclear Power Plant, Units 3 & 4
COL Application
Part 2, FSAR**

**Table 9.5.1-1R (Sheet 12 of 51)
CPNPP Units 3 & 4 Fire Protection Program Conformance with RG 1.189**

	Regulatory Position	Position Number	Conformance	Remarks
CP COL 9.5(1)	Where the evaluation of an fire protection program change is based on fire modeling, licensees should document that the fire models and methods used meet the NRC requirements. The licensee should also document that the models and methods used in the analyses were used within their limitations and with the rigor required by the nature and scope of the analyses. These analyses may use simple hand calculations or more complex computer models, depending on the specific conditions of the scenario being evaluated.	1.8.7	Conform	See Subsection 9.5.1.6.
	Fire prevention is the first line of defense-in-depth for fire protection. The fire prevention attributes of the program are directly related to the fire protection objective to minimize the potential for fire to occur. These attributes involve design and administrative measures that provide a reasonable level of assurance that fire hazards are adequately protected and managed and that fire consequences will be limited for those fires that do occur.	2.	Information Statement	Compliance statement not appropriate since this is an informational statement only.
CP COL 9.5(1)	Fire prevention administrative controls should include procedures to control handling and use of combustibles, prohibit storage of combustibles in plant areas important to safety, establish designated storage areas with appropriate fire protection, and control use of specific combustibles (e.g., wood) in plant areas important to safety.	2.1	Conform	See Subsection 9.5.1.6.
CP COL 9.5(1)	Bulk storage of combustible materials should be prohibited inside or adjacent to buildings or systems important to safety during all modes of plant operation. Procedures should govern the handling of and limit transient fire hazards such as combustible and flammable liquids, wood and plastic products, high-efficiency particulate air (HEPA) and charcoal filters, dry ion exchange resins, or other combustible materials in buildings containing systems or equipment important to safety during all phases of operation, particularly during maintenance, modification, or refueling operations.	2.1.1	Conform	See Subsection 9.5.1.6.

**Comanche Peak Nuclear Power Plant, Units 3 & 4
COL Application
Part 2, FSAR**

**Table 9.5.1-1R (Sheet 13 of 51)
CPNPP Units 3 & 4 Fire Protection Program Conformance with RG 1.189**

	Regulatory Position	Position Number	Conformance	Remarks
CP COL 9.5(1)	Fire prevention elements of the fire protection program should be maintained when plant modifications are made. The modification procedures should contain provisions that evaluate the impacts of modifications on the fire prevention design features and programs. The licensee should follow the guidelines of Regulatory Position 4.1.1 in the design of plant modifications. Personnel in the fire protection organization should review modifications of SSCs to ensure that fixed fire loadings are not increased beyond those accounted for in the fire hazards analysis, or if increased, suitable protection is provided and the fire hazards analysis is revised accordingly.	2.1.2	Conform	See Subsection 9.5.1.6.
CP COL 9.5(1)	Flammable and combustible liquids and gases are potentially significant fire hazards and procedures should clearly define the use, handling, and storage of these hazards. The handling, use, and storage of flammable and combustible liquids should, as a minimum, comply with the provisions of NFPA 30, "Flammable and Combustible Liquids Code."	2.1.3	Conform	See Subsection 9.5.1.6.
CP COL 9.5(2)	When an SSC important to safety is near installations such as flammable liquid or gas storage, the licensee should evaluate the risk of exposure fires (originating in such installations) to the SSCs and take appropriate protective measures. NFPA 80A, "Recommended Practice for Protection of Buildings from Exterior Fire Exposures," provides guidance on such exposure protection. NFPA 30 provides guidance relative to minimum separation distances from flammable and combustible liquid storage tanks. NFPA 55, "Standard for the Storage, Use, and Handling of Compressed Gases and Cryogenic Fluids in Portable and Stationary Containers, Cylinders, and Tanks," provides separation distances for gaseous and liquefied hydrogen. (See Regulatory Position 7.5 of this guide.) NFPA 58, "Liquefied Petroleum Gas Code," provides guidance for liquefied petroleum gas.	2.1.4	Conform	See Subsection 9.5.1.6.

**Comanche Peak Nuclear Power Plant, Units 3 & 4
COL Application
Part 2, FSAR**

**Table 9.5.1-1R (Sheet 14 of 51)
CPNPP Units 3 & 4 Fire Protection Program Conformance with RG 1.189**

	Regulatory Position	Position Number	Conformance	Remarks
CP COL 9.5(1)	Electrical equipment (permanent and temporary), hot work activities (e.g., open flame, welding, cutting and grinding), high-temperature equipment and surfaces, heating equipment (permanent and temporary installation), reactive chemicals, static electricity, and smoking are all potential ignition sources. Design, installation, modification, maintenance, and operational procedures and practices should control potential ignition sources.	2.2	Conform	See Subsection 9.5.1.6.
CP COL 9.5(1)	Work involving ignition sources such as welding and flame cutting should be done under closely controlled conditions. Persons performing and directly assisting in such work should be trained and equipped to prevent and combat fires. If this is not possible, a person qualified in fire protection should directly monitor the work and function as a fire watch.	2.2.1	Conform	See Subsection 9.5.1.6.
CP COL 9.5(1)	The use of temporary services at power reactor facilities is routine, especially to support maintenance and other activities during outages. In view of the magnitude and complexity of some temporary services, proper engineering and, once installed, maintenance of the design basis become significant. Plant administrative controls should provide for engineering review of temporary installations. These reviews should ensure that appropriate precautions, limitations, and maintenance practices are established for the term of such installations.	2.2.2	Conform	See Subsection 9.5.1.6.
CP COL 9.5(1)	Leak testing and similar procedures such as airflow determination should not use open flames or combustion-generated smoke. Procedures and practices should provide for control of temporary heating devices. Use of space heaters and maintenance equipment (e.g., tar kettles for roofing operations) in plant areas should be strictly controlled and reviewed by the plant's fire protection staff.	2.2.3	Conform	See Subsection 9.5.1.6.

**Comanche Peak Nuclear Power Plant, Units 3 & 4
COL Application
Part 2, FSAR**

**Table 9.5.1-1R (Sheet 15 of 51)
CPNPP Units 3 & 4 Fire Protection Program Conformance with RG 1.189**

Regulatory Position	Position Number	Conformance	Remarks	
CP COL 9.5(1)	The licensee should establish administrative controls to minimize fire hazards in areas containing SSCs important to safety. These controls should govern removal of waste, debris, scrap, oil spills, and other combustibles after completion of a work activity or at the end of the shift. Administrative controls should also include procedures for performing and maintaining periodic housekeeping inspections to ensure continued compliance with fire protection controls.	2.3	Conform	See Subsection 9.5.1.6.
CP COL 9.5(1)	The licensee should establish fire protection administrative controls to address the following: a. Fire protection features should be maintained and tested by qualified personnel. b. Impairments to fire barriers, fire detection, and fire suppression systems should be controlled by a permit system. c. Successful fire protection requires inspection, testing, and maintenance of the fire protection equipment. d. Fire barriers, including dampers, doors, and penetration seals, should be routinely inspected.	2.4	Conform	See Subsection 9.5.1.6.
	In general, the fire hazards analysis and regulatory requirements determine the scope of fire detection and suppression in the plant, whereas the applicable industry codes and standards (generally NFPA codes, standards, and recommended practices) determine the design, installation, and testing requirements of the systems and components. The design of fire detection systems should minimize the adverse effects of fires on SSCs important to safety. Automatic fire detection systems should be installed in all areas of the plant that contain or present an exposure fire hazard to SSCs important to safety. These fire detection systems should be capable of operating with or without offsite power.	3.1	Conform	The FHA (Appendix 9A), NRC regulations and NFPA codes and standards are used in the development of fire protection features for US-APWR.
	The fire detection and alarm system should be designed with objectives detailed in the RG.	3.1.1	Conform	RG 1.189, Rev. 1 followed extensively in the implementation of the fire protection program for the US-APWR plant.

**Comanche Peak Nuclear Power Plant, Units 3 & 4
COL Application
Part 2, FSAR**

**Table 9.5.1-1R (Sheet 16 of 51)
CPNPP Units 3 & 4 Fire Protection Program Conformance with RG 1.189**

	Regulatory Position	Position Number	Conformance	Remarks
CP COL 9.5(2)	NFPA 22, "Standard for Water Tanks for Private Fire Protection," and NFPA 24, "Standard for the Installation of Private Fire Service Mains and Their Appurtenances," provide guidance for fire protection water supplies	3.2.1	Conform	See Subsection 9.5.1.2.2.
CP COL 9.5(2)	Fire pump installations should conform to NFPA 20.	3.2.2	Conform	See Subsection 9.5.1.2.2.
CP COL 9.5(2)	An underground yard fire main loop should be installed to furnish anticipated water requirements. NFPA 24 provides appropriate guidance for such installation.	3.2.3	Conform	See Subsection 9.5.1.2.3.
	Automatic suppression should be installed as determined by the fire hazards analysis and as necessary to protect redundant systems or components necessary for safe shutdown and SSCs important to safety.	3.3	Conform	See Appendix 9A for areas where automatic suppression as determined by the FHA is to be installed.
	Equipment important to safety that does not itself require protection by water-based suppression systems, but is subject to unacceptable damage if wetted by suppression system discharge, should be appropriately protected (e.g., water shields or baffles). Drains should be provided as required to protect equipment important to safety from flooding damage.	3.3.1	Conform	Floor drains and raised equipment pedestals are used as well as spray shields where necessary to protect equipment that can suffer unacceptable damage from wetting.
	Water sprinkler and spray suppression systems are the most widely used means of implementing automatic water-based fire suppression. Sprinkler and spray systems should, at a minimum, conform to requirements of appropriate standards such as NFPA 13 and NFPA 15.	3.3.1.1	Conform	Sprinkler systems are designed per NFPA 13 and spray systems designed per NFPA 15.
	Water mist suppression systems may be useful in specialized situations, particularly in those areas where the application of water needs to be restricted. Water mist systems should conform to appropriate standards such as NFPA 750, "Standard on Water Mist Fire Protection Systems."	3.3.1.2	Conform	

**Comanche Peak Nuclear Power Plant, Units 3 & 4
COL Application
Part 2, FSAR**

**Table 9.5.1-1R (Sheet 17 of 51)
CPNPP Units 3 & 4 Fire Protection Program Conformance with RG 1.189**

Regulatory Position	Position Number	Conformance	Remarks
Certain fires, such as those involving flammable liquids, respond well to foam suppression. Consideration should be given to the use of foam sprinkler and spray systems. Foam sprinkler and spray systems should conform to appropriate standards such as NFPA 16, "Standard for the Installation of Deluge Foam-Water Sprinkler and Foam-Water Spray Systems," and NFPA 11, "Standard for Low-, Medium-, and High-Expansion Foam."	3.3.1.3	N/A	No foam sprinkler or spray systems are used for the US-APWR plant.
Gaseous systems should be evaluated for potential impacts on the habitability of areas containing equipment important to safety where operations personnel perform safe-shutdown actions or where firefighting activities may become necessary. Where gas suppression systems are installed, openings in the area should be adequately sealed or the suppression system should be sized to compensate for the loss of the suppression agent through floor drains and other openings.	3.3.2	The US-APWR plant uses an environmentally friendly clean gaseous fire suppression agent that does not pose a hazard to operations personnel.	See Appendix 9A.
Carbon dioxide extinguishing systems should comply with the requirements of NFPA 12. Where automatic carbon dioxide systems are used, they should be equipped with a predischARGE alarm system and a discharge delay to permit personnel egress. Provisions for locally disarming automatic carbon dioxide systems should be key locked and under strict administrative control.	3.3.2.1	No carbon dioxide extinguishing systems are used for CPNPP plant.	
Halon fire extinguishing systems should comply with the requirements of NFPA 12A. Where automatic Halon systems are used, they should be equipped with a predischARGE alarm and a discharge delay to permit personnel egress. Provisions for locally disarming automatic Halon systems should be key locked and under strict administrative control.	3.3.2.2	No Halon fire extinguishing systems are used for the US-APWR plant.	

**Comanche Peak Nuclear Power Plant, Units 3 & 4
COL Application
Part 2, FSAR**

**Table 9.5.1-1R (Sheet 18 of 51)
CPNPP Units 3 & 4 Fire Protection Program Conformance with RG 1.189**

Regulatory Position	Position Number	Conformance	Remarks
	3.3.2.3	Conform	Clean agent fire suppression systems conform with applicable NFPA 2001 guidance.
	3.4	Conform	Adequate manual hose stations and portable fire extinguishers installed through the US-APWR.
	3.4.1	Conform	See Appendix 9A.
CP COL 9.5(2)	3.4.2	Conform	See subsection 9.5.1.2.3.

**Comanche Peak Nuclear Power Plant, Units 3 & 4
COL Application
Part 2, FSAR**

**Table 9.5.1-1R (Sheet 19 of 51)
CPNPP Units 3 & 4 Fire Protection Program Conformance with RG 1.189**

Regulatory Position	Position Number	Conformance	Remarks
CP COL 9.5(1) For flammable and combustible liquid fire hazards, consideration should be given to the use of foam systems for manual fire suppression protection. These systems should comply with the requirements of NFPA 11.	3.4.3	N/A	Based on the FHA (Appendix 9A), no installed foam systems are proposed for CPNPP Units 3 and 4. The plant fire brigade has foam carts available for manual fire fighting efforts.
Fire extinguishers should be provided in areas that contain or could present a fire exposure hazard to equipment important to safety. Extinguishers should be installed with due consideration given to possible adverse effects on equipment important to safety installed in the area. NFPA 10, "Standard for Portable Fire Extinguishers," provides guidance on the installation (including location and spacing) and the use and application of fire extinguishers.	3.4.4	Conform	See Appendix 9A.
Some fixed fire suppression systems may be manually actuated (e.g., fixed suppression systems provided in accordance with Section III.G.3 of Appendix R to 10 CFR 50). Manual actuation is generally limited to water spray systems and should not be used for gaseous suppression systems except when the system provides backup to an automatic water suppression system.	3.4.5	N/A	The US-APWR is an advanced light water reactor plant and complies with applicable regulations for an advanced plant. Manually actuated water spray systems in the US-APWR are only used for charcoal filter bed protection.
CP COL 9.5(1) A site fire brigade trained and equipped for firefighting should be established and should be on site at all times to ensure adequate manual firefighting capability for all areas of the plant containing SSCs important to safety. The fire brigade leader should have ready access to keys for any locked doors.	3.5.1	Conform	See Subsection 9.5.1.6.1.6.

**Comanche Peak Nuclear Power Plant, Units 3 & 4
COL Application
Part 2, FSAR**

**Table 9.5.1-1R (Sheet 20 of 51)
CPNPP Units 3 & 4 Fire Protection Program Conformance with RG 1.189**

	Regulatory Position	Position Number	Conformance	Remarks
CP COL 9.5(1)	The equipment provided for the brigade should consist of personal protective equipment such as turnout coats, bunker pants, boots, gloves, hard hats, emergency communications equipment, portable lights, portable ventilation equipment, and portable extinguishers. Self-contained breathing apparatuses using full-face positive-pressure masks approved by the National Institute for Occupational Safety and Health (approval formerly given by the U.S. Bureau of Mines) should be provided for fire brigade, damage control, and MCR personnel.	3.5.1.2	Conform	See Subsection 9.5.1.6.1.8.
CP COL 9.5(1)	Procedures should be established to control actions by the fire brigade upon notification by the MCR of a fire and to define firefighting strategies.	3.5.1.3	Conform	See Subsection 9.5.1.6.3.1.
CP COL 9.5(1)	Fire brigade drills should be performed in the plant so that the fire brigade can practice as a team. Drills should be performed quarterly for each shift fire brigade. Each fire brigade member should participate in at least two drills annually.	3.5.1.4	Conform	See Subsection 9.5.1.6.2.1.3.
CP COL 9.5(1)	Onsite fire brigades typically fulfill the role of first responder, but may not have sufficient personnel, equipment, and capability to handle all possible fire events. Arrangements with offsite fire services may be necessary to augment onsite firefighting capabilities, consistent with the fire hazards analysis and prefire planning documents. The fire protection program should describe the capabilities (e.g., equipment compatibility, training, drills, and command control) of offsite responders.	3.5.2	Conform	See Subsection 9.5.1.6.1.7.
CP COL 9.5(1)	The local offsite fire departments that provide back up manual firefighting resources should have the following capabilities: a. Personnel and equipment with capacities consistent with those assumed in the plant's fire hazards analysis and prefire plans. b. Hose threads or adapters to connect with onsite hydrants, hose couplings, and standpipe risers.	3.5.2.1	Conform	See Subsection 9.5.1.6.1.7.
	Local offsite fire department personnel who provide back up manual firefighting resources should be trained.	3.5.2.2	Conform	See Subsection 9.5.1.6.1.7.

**Comanche Peak Nuclear Power Plant, Units 3 & 4
COL Application
Part 2, FSAR**

**Table 9.5.1-1R (Sheet 21 of 51)
CPNPP Units 3 & 4 Fire Protection Program Conformance with RG 1.189**

Regulatory Position	Position Number	Conformance	Remarks
CP COL 9.5(1) The licensee should establish written mutual aid agreements between the utility and the offsite fire departments that are listed in the fire hazards analysis and prefire plans as providing a support response to a plant fire.	3.5.2.3	Conform	See Subsection 9.5.1.6.1.7.
These agreements should delineate fire protection authorities, responsibilities, and accountabilities with regard to responding to plant fire or emergency events, including the fire event command structure between the plant fire brigade and offsite responders.			
This section provides guidance on building layout (e.g., fire areas and zones), materials of construction, and building system design (e.g., electrical, HVAC, lighting, and communication systems) important to effective fire prevention and protection.	4.1	Information	No compliance statement is appropriate for this Reg. guide section lead in.
Information introduction to this section of RG 1.189			
According to GDC 3, noncombustible and heat-resistant materials must be used wherever practical throughout the unit. Interior wall and structural components, thermal insulation materials, radiation shielding materials, and soundproofing should be noncombustible. The fire hazards analysis should identify in situ combustible materials used in plant SSCs and specify suitable fire protection.	4.1.1	Conform	See Appendix 9A for the selection of fire areas, fire compartments, description of materials used for construction and fire protection provided.
Interior finishes should be noncombustible.	4.1.1.1	Conform	See below.
Interior finishes should be noncombustible (see the "Glossary" section of this guide) or listed by an approving laboratory.	4.1.1.2	Conform	US-APWR interior finishes conform to the items listed as acceptable without test in the text of this section of RG 1.189 or meet the acceptable industry testing listed.
In accordance with GDC 3, SSCs important to safety must be designed and located to minimize the probability and effect of fires and explosions. The concept of compartmentalization meets GDC 3, in part, by utilizing passive fire barriers to subdivide the plant into separate areas or zones.	4.1.2	Conform	See appendix 9A for fire area and fire compartment selection for the US-APWR.

**Comanche Peak Nuclear Power Plant, Units 3 & 4
COL Application
Part 2, FSAR**

**Table 9.5.1-1R (Sheet 22 of 51)
CPNPP Units 3 & 4 Fire Protection Program Conformance with RG 1.189**

Regulatory Position	Position Number	Conformance	Remarks
A fire area is defined as that portion of a building or plant that is separated from other areas by fire barriers, including components of construction such as beams, joists, columns, penetration seals or closures, fire doors, and fire dampers. Fire barriers that define the boundaries of a fire area should have a fire-resistance rating of 3 hours or more.	4.1.2.1	Conform	US-APWR fire area boundaries meet 3-hour fire resistance and are protected with appropriately rated fire dampers, penetration seals, and fire doors.
Fire zones are subdivisions of a fire area and are typically based on fire hazards analyses that demonstrate that the fire protection systems and features within the fire zone provide an appropriate level of protection for the associated hazards. Fire zone concepts may be used to establish zones within fire areas where further subdivision into additional fire areas is not practical on the basis of existing plant design and layout (e.g., inside containment).	4.1.2.2	Conform	Fire zones associated with selected fire areas are described in Appendix 9A.
The plant layout should provide adequate means of access to all plant areas for manual fire suppression. The plant layout should also allow for safe access and egress to areas for personnel performing safe-shutdown operations.	4.1.2.3	Conform	
Electric cable construction should pass the flame test in IEEE Standard 383, "IEEE Standard for Type Test of Class IE Electric Cables, Field Splices, and Connections for Nuclear Power Generating Stations," or IEEE Standard 1202, "IEEE Standard for Flame Testing of Cables for Use in Cable Trays in Industrial and Commercial Occupancies." (This does not imply that cables passing either test will not require additional fire protection.) New reactor fiber optic cable insulation and jacketing should also meet the fire and flame test requirements of IEEE 383 or IEEE 1202.	4.1.3.1	Conform	

**Comanche Peak Nuclear Power Plant, Units 3 & 4
COL Application
Part 2, FSAR**

**Table 9.5.1-1R (Sheet 23 of 51)
CPNPP Units 3 & 4 Fire Protection Program Conformance with RG 1.189**

Regulatory Position	Position Number	Conformance	Remarks
Only metal should be used for cable trays. Only metallic tubing should be used for conduit. Thin-wall metallic tubing should not be used. Flexible metallic tubing should only be used in short lengths to connect components to equipment. Other raceways should be made of noncombustible material. Cable raceways should be used only for cables.	4.1.3.2	Conform	
Redundant cable systems important to safety outside the cable spreading room should be separated from each other and from potential fire exposure hazards in nonsafety-related areas by fire barriers with a minimum fire rating of 3 hours to the extent feasible. Those fire areas that contain cable trays important to safety should be provided with fire detection. Cable trays should be accessible for manual firefighting and cables should be designed to allow wetting down with fire suppression water without electrical faulting. Manual hose stations and portable hand extinguishers should be provided.	4.1.3.3	Conform	
Redundant systems used to mitigate the consequences of design-basis accidents but not necessary for safe shutdown may be lost to a single exposure fire. However, protection should be provided so that a fire within only one such system will not damage the redundant system.	4.1.3.4	Conform	US-APWR design employs 4 redundant trains of safety systems used for mitigation of design basis accidents. Each train is completely separated by 3-hour rated fire barriers.
Transformers that present a fire hazard to equipment important to safety should be protected as described in Regulatory Position 7.3 of this guide.	4.1.3.5	Conform	See Regulatory Position 7.3.
Electrical cabinets present an ignition source for fires and a potential for explosive electrical faults that can result in damage not only to the cabinet of origin, but also to equipment, cables, and other electrical cabinets in the	4.1.3.6	Conform	

**Comanche Peak Nuclear Power Plant, Units 3 & 4
COL Application
Part 2, FSAR**

**Table 9.5.1-1R (Sheet 24 of 51)
CPNPP Units 3 & 4 Fire Protection Program Conformance with RG 1.189**

Regulatory Position	Position Number	Conformance	Remarks
vicinity of the cabinet of origin. Fire protection systems and features provided for the general area containing the cabinet may not be adequate to prevent damage to adjacent equipment, cables, and cabinets following an energetic electrical fault. Energetic electrical faults are more of a concern with high-voltage electrical cabinets [i.e., 480 volts (V) and above]. High-voltage cabinets should be provided with adequate spatial separation or substantial physical barriers to minimize the potential for an energetic electrical fault to damage adjacent equipment, cables, or cabinets important to safety.			
Suitable design of the ventilation systems can limit the consequences of a fire by preventing the spread of the products of combustion to other fire areas. It is important that means be provided to ventilate, exhaust, or isolate the fire area as required and that consideration be given to the consequences of ventilation system failure caused by the fire, resulting in a loss of control for ventilating, exhausting, or isolating a given fire area.	4.1.4	Informational statement	See Appendix 9A for additional discussion on HVAC impact and smoke removal.
Filters for particulate and gaseous effluents may be fabricated of combustible media (e.g., HEPA and charcoal filters). The ignition and burning of these filters may result in a direct release of radioactive material to the environment or may provide an unfiltered pathway upon failure of the filter. Filter combustion may spread fire to other areas.	4.1.4.1	Informational statement	US-APWR design provides protection of HVAC filters and filter media from the damaging affects of a fire.
Smoke from fires can be toxic, corrosive, and may obscure visibility for emergency egress and access to plant areas. Smoke control and removal may be necessary to support manual suppression activities and safe-shutdown operations.	4.1.4.2	Informational statement	See Appendix 9A for a discussion of smoke removal for selected fire areas.

**Comanche Peak Nuclear Power Plant, Units 3 & 4
COL Application
Part 2, FSAR**

**Table 9.5.1-1R (Sheet 25 of 51)
CPNPP Units 3 & 4 Fire Protection Program Conformance with RG 1.189**

Regulatory Position	Position Number	Conformance	Remarks
Protection of plant operations staff from the effects of fire and fire suppression (e.g., gaseous suppression agents) may be necessary to ensure safe shutdown of the plant. For MCR evacuation, egress pathways and remote control stations should also be habitable. Consideration should be given to protection of safe-shutdown areas from infiltration of gaseous suppression agents. The capability to ventilate, exhaust, or isolate is particularly important to ensure the habitability of rooms or spaces that should be attended in an emergency. In the design, provision should be made for personnel access to and escape routes from each fire area.	4.1.4.3	Conform	For the US-APWR, the gaseous suppression agent used in R/B areas is a safe clean agent that does not pose a safety concern for personnel.
Redundant safe-shutdown components may be separated by fire-resistant walls, floors, enclosures, or other types of barriers. For the fire barriers to be effective in limiting the propagation of fire, ventilation duct penetrations of fire barriers should be protected by means of fire dampers that are arranged to automatically close in the event of fire. NFPA 90A, "Standard for the Installation of Air Conditioning and Ventilating Systems," provides additional guidance.	4.1.4.4	Conform	
Floor drains sized to remove expected firefighting water without flooding equipment important to safety should be provided in areas where fixed water fire suppression systems are installed. Floor drains should also be provided in other areas where hand hose lines may be used if such firefighting water could cause unacceptable damage to equipment important to safety in the area. Facility design should ensure that fire water discharge in one area does not impact equipment important to safety in adjacent areas.	4.1.5	Conform	
Emergency lighting should be provided throughout the plant as necessary to support fire suppression actions and safe-shutdown operations, including access and egress pathways to safe shutdown areas during a fire event.	4.1.6	Conform	

**Comanche Peak Nuclear Power Plant, Units 3 & 4
COL Application
Part 2, FSAR**

**Table 9.5.1-1R (Sheet 26 of 51)
CPNPP Units 3 & 4 Fire Protection Program Conformance with RG 1.189**

Regulatory Position	Position Number	Conformance	Remarks
	4.1.6.1	Conform	
	4.1.6.2	Conform	
CP COL 9.5(1)	4.1.7	Conform	In plant repeaters used where required.
CP COL 9.5(2)	4.1.8	Conform	US-APWR design addresses in situ explosion hazards and provides protection. See Subsection 9.5.1.6.
	4.2.1	Conform	The US-APWR is a new reactor design and minimizes reliance on localized electrical raceway fire barrier systems. Where used, localized barriers are in accordance with Appendix C qualification requirements. See also Regulatory Position 8.2.
enhanced fire protection criteria for new reactors described in Regulatory Position 8.2 of this guide.			

**Comanche Peak Nuclear Power Plant, Units 3 & 4
COL Application
Part 2, FSAR**

**Table 9.5.1-1R (Sheet 27 of 51)
CPNPP Units 3 & 4 Fire Protection Program Conformance with RG 1.189**

Regulatory Position	Position Number	Conformance	Remarks
Wall, floor, and ceiling construction should be noncombustible. (See Regulatory Position 4.1.1 of this guide.) NFPA 221, "Standard for High-Challenge Fire Walls and Fire Barrier Walls," can be used as guidance for construction of fire barrier walls. Materials of construction for walls, floors, and ceilings serving as fire barriers should be rated by approving laboratories in hours of resistance to fire.	4.2.1.1	Conform	The US-APWR uses construction methods that result in noncombustible wall, floor, and ceiling components in safety-related and important to safety areas.
Building design should ensure that door openings are properly protected. These openings should be protected with fire doors that have been qualified by a fire test.	4.2.1.2	Conform	
Building design should ensure that ventilation openings are properly protected. These openings should be protected with fire dampers that have been fire tested. In addition, the construction and installation techniques for ventilation openings through fire barriers should be qualified by fire endurance tests. For ventilation ducts that penetrate or terminate at a fire wall, guidance in NFPA 90A indicates that ventilation fire dampers should be installed within the fire wall penetration for barriers with a fire rating greater than or equal to 2 hours. NFPA 90A requires that fire dampers be installed in all air transfer openings within a rated wall.	4.2.1.3	Conform	
Openings through fire barriers for pipe, conduit, and cable trays that separate fire areas should be sealed or closed to provide a fire-resistance rating at least equal to that required of the barrier itself. Openings inside conduit larger than 102 mm (4 in.) in diameter should be sealed at the fire barrier penetration. Openings inside	4.2.1.4	Conform	

**Comanche Peak Nuclear Power Plant, Units 3 & 4
COL Application
Part 2, FSAR**

**Table 9.5.1-1R (Sheet 28 of 51)
CPNPP Units 3 & 4 Fire Protection Program Conformance with RG 1.189**

Regulatory Position	Position Number	Conformance	Remarks
conduit 102 mm (4 in.) or less in diameter should be sealed at the fire barrier unless the conduit extends at least 1.5 m (5 ft) on each side of the fire barrier and is sealed either at both ends or at the fire barrier with material to prevent the passage of smoke and hot gases. Fire barrier penetrations that maintain environmental isolation or pressure differentials should be qualified by test to maintain the barrier integrity under such conditions.			
Structural fire barriers—The design adequacy of fire barrier walls, floors, ceilings, and enclosures should be verified by fire endurance testing. The NRC fire protection guidance refers to the guidance of NFPA 251 and ASTM E-119, “Standard Test Methods for Fire Tests of Building Construction and Materials,” as acceptable test methods for demonstrating fire endurance performance. The guidance of NFPA 251 and ASTM E-119 should be consulted with regard to construction, materials, workmanship, and details such as dimensions of parts and the size of the specimens to be tested. In addition, NFPA 251 and ASTM E-119 should be consulted with regard to the placement of thermocouples on the specimen.	4.2.1.5.a	Conform	
Penetration fire barriers—Penetration fire barriers should be qualified by tests conducted by an independent testing authority in accordance with the provisions of NFPA 251 or ASTM E-119. In addition, ASTM E-814, “Standard Test Method for Fire Tests of Through-Penetration Fire Stops,” or IEEE Standard 634, “IEEE Standard Cable Penetration Fire Stop Qualification Test,” could be used in the development of a standard fire test.	4.2.1.5.b	Conform	
The results of fire test programs that include a limited selection of test specimens that have been	4.2.1.6	Conform	
specifically designed to encompass or bound the entire population of in-plant penetration seal configurations may be acceptable.			
Structural steel forming a part of or supporting fire barriers should be	4.2.2	Conform	

**Comanche Peak Nuclear Power Plant, Units 3 & 4
COL Application
Part 2, FSAR**

**Table 9.5.1-1R (Sheet 29 of 51)
CPNPP Units 3 & 4 Fire Protection Program Conformance with RG 1.189**

Regulatory Position	Position Number	Conformance	Remarks
protected to provide fire resistance equivalent to that required of the barrier. Where the structural steel is not protected and has a lower fire rating than the required rating of the fire barrier, the fire hazards analysis should justify the configuration by demonstrating the temperature that the steel will reach during fire and the ability of the steel to carry the required loads at that temperature.			
Redundant cable systems important to safety should be separated from each other and from potential fire exposure hazards in accordance with the separation means of Regulatory Position 5.5.a–c of this guide.	4.2.3.1	Conform	
Licenses should request an exemption or deviation, as appropriate, when relying on fire-rated cables to meet NRC requirements for protection of safe-shutdown systems or components from the effects of fire. (See Regulatory Position 1.8 of this guide.)	4.2.3.2	N/A	No exemptions are requested as a result of relying on fire rated cables.
Fire stops should be installed every 6.1 m (20 ft) along horizontal cable routings in areas important to safety that are not protected by automatic water systems. Vertical cable routings should have fire stops installed at each floor-ceiling level. Between levels or in vertical cable chases, fire stops should be installed at the mid-height if the vertical run is 6.1 m (20 ft) or more, but less than 9.1 m (30 ft) or at 4.6-m (15-ft) intervals in vertical runs of 9.1 m (30 ft) or more unless such vertical cable routings are protected by automatic water systems directed on the cable	4.2.3.3	Conform	
trays. Individual fire stop designs should prevent the propagation of a fire for a minimum period of 30 minutes when tested for the largest number of cable routings and maximum cable density.			

**Comanche Peak Nuclear Power Plant, Units 3 & 4
COL Application
Part 2, FSAR**

**Table 9.5.1-1R (Sheet 30 of 51)
CPNPP Units 3 & 4 Fire Protection Program Conformance with RG 1.189**

Regulatory Position	Position Number	Conformance	Remarks
Fire barriers relied upon to protect post-fire shutdown-related systems and to meet the separation means discussed in Regulatory Position 5.3 should have a fire rating of either 1 or 3 hours.	4.3.1	Conform	The US-APWR utilizes 3-hour fire rated barriers between redundant trains of safety-related equipment. Only safety-related equipment is relied upon for post fire shutdown.
<p>The fire endurance qualification test for fire barrier materials applied directly to a raceway or component is considered to be successful if all three of the following conditions are met:</p> <p>a. The average unexposed side temperature of the fire barrier system, as measured on the exterior surface of the raceway or component, did not exceed 139 °C (250 °F) above its initial temperature.</p> <p>b. Irrespective of the unexposed side temperature rise during the fire test, if cables or components are included in the fire barrier test specimen, a visual inspection is performed. Cables should not show signs of degraded conditions resulting from the thermal effects of the fire exposure.</p> <p>c. The cable tray, raceway, or component fire barrier system remained intact during the fire exposure and water hose stream test without developing any openings through which the cable tray, raceway, or component (e.g., cables) is visible.</p>	4.3.2	Conform	The US-APWR design minimizes the used of raceway and component fire barriers. In limited areas, where barriers are used, this qualification and Appendix C criteria are satisfied.
The following are acceptable placements of thermocouples for determining the thermal performance of raceway or cable tray fire barrier systems that contain cables during fire	4.3.2.1	Conform	The US-APWR design minimizes the used of raceway and component fire barriers. In limited areas, where

**Comanche Peak Nuclear Power Plant, Units 3 & 4
COL Application
Part 2, FSAR**

**Table 9.5.1-1R (Sheet 31 of 51)
CPNPP Units 3 & 4 Fire Protection Program Conformance with RG 1.189**

Regulatory Position	Position Number	Conformance	Remarks
<p>exposure:</p> <p>a. Conduits—The temperature rise on the unexposed surface of a fire barrier system installed on a conduit should be measured by placing the thermocouples every 152 mm (6 in.) on the exterior conduit surface underneath the fire barrier material.</p> <p>b. Cable trays—The temperature rise on the unexposed surface of a fire barrier system installed on a cable tray should be measured by placing the thermocouples on the exterior surface of the tray side rails between the cable tray side rail and the fire barrier material.</p> <p>c. Junction boxes—The temperature rise on the unexposed surface of a fire barrier system installed on junction boxes should be measured by placing thermocouples on either the inside or the outside of each junction box surface.</p> <p>d. Airdrops—The internal airdrop temperatures should be measured by thermocouples placed every 305 mm (12 in.) on the cables routed within the airdrop and by a stranded American Wire Gauge 8 bare copper conductor routed inside and along the entire length of the airdrop system with thermocouples installed every 152 mm (6 in.) along the length of the copper conductor.</p>			barriers are used, this qualification and Appendix C criteria are satisfied.
<p>The following are acceptable thermocouple placements for determining the thermal performance of raceway or cable tray fire barrier systems that do not contain cables.</p> <p>a. Conduits—The temperature rise of the unexposed surface of a fire barrier system installed on a conduit should be measured by placing thermocouples every 152 mm (6 in.) on the exterior conduit surface between the conduit and the unexposed surface of the fire barrier material.</p> <p>b. Cable trays—The temperature rise on the unexposed surface of a fire barrier system installed on a</p>	4.3.2.2	Conform	The US-APWR design minimizes the used of raceway and component fire barriers. In limited areas, where barriers are used, this qualification and Appendix C criteria are satisfied.

**Comanche Peak Nuclear Power Plant, Units 3 & 4
COL Application
Part 2, FSAR**

**Table 9.5.1-1R (Sheet 32 of 51)
CPNPP Units 3 & 4 Fire Protection Program Conformance with RG 1.189**

Regulatory Position	Position Number	Conformance	Remarks
<p>cable tray should be measured by placing thermocouples every 152 mm (6 in.) on the exterior surface of each tray's side rails between the side rail and the fire barrier material.</p> <p>c. Junction boxes—The temperature rise on the unexposed surface of a fire barrier system installed on junction boxes should be measured by placing thermocouples on either the inside or the outside of each junction box surface.</p> <p>d. Airdrops—The internal airdrop temperatures should be measured by a stranded AWG 8 bare copper conductor routed inside and along the entire length of the airdrop system with thermocouples installed every 152 mm (6 in.) along the length of the copper conductor.</p>			
<p>Temperature conditions on the unexposed surfaces of the fire barrier material during the fire test will be determined by averaging the temperatures measured by the thermocouples installed in or on the raceway. To determine these temperature conditions, the thermocouples measuring similar areas of the fire barrier should be averaged together. Acceptance will be based on the individual averages.</p>	4.3.2.3	Conform	The US-APWR design minimizes the used of raceway and component fire barriers. In limited areas, where barriers are used, this qualification and Appendix C criteria are satisfied.
<p>NFPA 251 and ASTM E-119 allow flexibility in hose stream testing. The standards allow the hose stream test to be performed on a duplicate test specimen subjected to a fire endurance test for a period equal to one-half of that indicated as the fire-resistance rating, but not for more than 1 hour (e.g., 30-minute fire exposure to qualify a 1-hour fire-rated barrier).</p>	4.3.3	N/A	Informational statement
<p>During fire tests of raceway fire barrier systems, thermal damage to the cables has led to cable jacket and insulation degradation without the loss of circuit integrity as monitored using ANI criteria</p>	4.3.4	N/A	Informational statement.

**Comanche Peak Nuclear Power Plant, Units 3 & 4
COL Application
Part 2, FSAR**

**Table 9.5.1-1R (Sheet 33 of 51)
CPNPP Units 3 & 4 Fire Protection Program Conformance with RG 1.189**

Regulatory Position	Position Number	Conformance	Remarks
[applied voltage of 8–10V direct current (dc)]. Since cable voltages used for ANI circuit integrity tests do not replicate cable operating voltages, loss of cable insulation conditions can exist during the fire test without a dead short occurring. It is expected that if the cables were at rated power and current, a fault would propagate.			
Comparison of the fire barrier internal time-temperature profile measured during the fire endurance test to existing cable performance data, such as data from Environmental Qualification tests, could be proposed to the staff as a method for demonstrating cable functionality. Environmental Qualification testing is typically performed to rigorous conditions, including rated voltage and current. By correlating the Environmental Qualification test time-temperature profile to the fire test time-temperature profile, the Environmental Qualification test data would provide a viable mechanism to ensure cable functionality.	4.3.4.1	N/A	Informational statement.
The nuclear industry uses two principal materials as cable insulation and cable jackets, thermoplastics and thermosetting polymeric materials. A thermoplastic material can be softened and resoftened by heating and reheating. Conversely, thermosetting cable insulation materials cure by chemical reaction and do not soften when heated. Under excessive heating, thermosetting insulation becomes stiff and brittle. Electrical faults may be caused by softening and flowing of thermoplastic insulating materials at temperatures as low as 149 °C (300 °F). Thermosetting electrical conductor insulation materials usually retain their electrical properties under short-term exposures to temperatures as high as 260 °C (500 °F).	4.3.4.2	N/A	Informational statement.

**Comanche Peak Nuclear Power Plant, Units 3 & 4
COL Application
Part 2, FSAR**

**Table 9.5.1-1R (Sheet 34 of 51)
CPNPP Units 3 & 4 Fire Protection Program Conformance with RG 1.189**

Regulatory Position	Position Number	Conformance	Remarks
Air oven tests can evaluate the functionality of cables for those cable tray or raceway fire barrier test specimens tested without cables. This testing method consists of exposing insulated wires and cables at rated voltage to elevated temperatures in a circulating air oven. The temperature profile for regulating the temperature in the air oven during this test is the temperature measured by the American Wire Gauge 8 bare copper conductor during the fire exposure of those cable tray or raceway test specimens that were tested without cables.	4.3.4.3	N/A	Informational statement.
The following analysis, which is based on determining whether a specific insulation material will maintain electrical integrity and operability within a raceway fire barrier system during and after an external fire exposure, is an acceptable method for evaluating cable functionality. To determine cable functionality, it is necessary to consider the operating cable temperatures within the fire barrier system at the onset of the fire exposure and the thermal exposure threshold temperature of the cable.	4.3.4.4	N/A	Informational statement.
When considering the consequences of a fire in a given fire area during the evaluation of safe shutdown capabilities of the plant, it should be demonstrated that one success path of equipment and electrical circuits that can be used to bring the reactor to hot shutdown/standby conditions, remains free of fire damage.	5.	N/A	The US-APWR is an evolutionary plant that complies with Position 8.2.
During post-fire shutdown, the reactor coolant system process variables must be maintained within those predicted for a loss of normal ac power, and the fission product boundary integrity shall not be affected, i.e., there shall be no fuel clad damage, rupture of any	5.1	Conform	The US-APWR is an evolutionary plant that complies with Position 8.2.

**Comanche Peak Nuclear Power Plant, Units 3 & 4
COL Application
Part 2, FSAR**

**Table 9.5.1-1R (Sheet 35 of 51)
CPNPP Units 3 & 4 Fire Protection Program Conformance with RG 1.189**

Regulatory Position	Position Number	Conformance	Remarks
primary coolant boundary, or rupture of the containment boundary. Licensees should ensure that fire protection features are provided for structures, systems, and components important to safe shutdown that are capable of limiting fire damage so that one success path of systems necessary to achieve and maintain hot shutdown conditions from either the MCR or emergency control station(s) is free of fire damage.			
For normal safe shutdown, redundant systems necessary to achieve cold shutdown may be damaged by a single fire, but damage should be limited so that at least one success path can be repaired or made operable within 72 hours using onsite capability or within the time period required to achieve a safe-shutdown condition, if less than 72 hours.	5.2	N/A	The US-APWR as an evolutionary plant design must be able to achieve cold shutdown without equipment repairs being involved. Cold shutdown can be achieved as a normal course of action using two of the four redundant safety trains.
Fire barriers or automatic suppression, or both, should be installed as necessary to protect redundant systems or components necessary for safe shutdown.	5.3	Conform	Fire barriers are installed to provide separation of redundant safety trains. Automatic suppression is installed to minimize damage to safety-related equipment where app.
CP COL 9.5(2) The post-fire safe-shutdown analysis must ensure that one success path of shutdown SSCs remains free of fire damage for a single fire in any single plant fire area. The NRC acknowledges Chapter 3 of industry guidance document, NEI-00-01, Revision 1, in RIS 2005-30, as providing an acceptable deterministic methodology for analysis of post-fire safe-shutdown circuits, when applied in conjunction with the RIS.	5.3.1	Conform	See FHA (Appendix 9A.) See Subsection 9.5.1.3

**Comanche Peak Nuclear Power Plant, Units 3 & 4
COL Application
Part 2, FSAR**

**Table 9.5.1-1R (Sheet 36 of 51)
CPNPP Units 3 & 4 Fire Protection Program Conformance with RG 1.189**

Regulatory Position	Position Number	Conformance	Remarks
The licensee should evaluate the circuits associated with Hi/Low pressure interfaces for the potential to adversely affect safe shutdown. For example, the residual heat removal (RHR) system is generally a low-pressure system that interfaces with the high-pressure primary coolant system. Thus, the interface most likely consists of two redundant and independent motor-operated valves. Both of these two motor-operated valves and their power and control cables may be subject to damage from a single fire. This single fire could cause the two valves to spuriously open, resulting in an interfacing system LOCA through the subject Hi/Low-pressure system interface.	5.3.2	Conform	The US-APWR design considers the impact of high/low pressure interfaces.
The post-fire safe-shutdown analysis should describe the methodology necessary to accomplish safe shutdown, including any operator actions required. Manual actions may not be credited in lieu of providing the required protection of redundant systems located in the same fire area required by Section III.G.2 of Appendix R to 10 CFR 50, unless the NRC has reviewed and approved a specific operator manual action for a specific plant through the exemption process of 10 CFR 50.12.	5.3.3	Conform	Four redundant trains of safety-related equipment are individually separated with 3-hour fire rated barriers. Should MCR fire involvement prevent safe operation, a completely independent remote shutdown console is located in a separate fire area. No operator manual actions are required, except evacuation and switch transfer for the MCR fire event.
The post-fire safe-shutdown circuit analysis must address all possible fire-induced failures, including multiple spurious actuations. Although some licensees have based this analysis on the assumption that multiple spurious actuations will not occur simultaneously or in rapid succession, cable fire testing performed by the industry had demonstrated that multiple	5.3.4	Conform	Conformance with this regulatory position is based on the criteria of RG 1.189, Rev. 1 not the one-at-a-time assumption used in NFPA 804 that is not endorsed by the NRC.

**Comanche Peak Nuclear Power Plant, Units 3 & 4
COL Application
Part 2, FSAR**

**Table 9.5.1-1R (Sheet 37 of 51)
CPNPP Units 3 & 4 Fire Protection Program Conformance with RG 1.189**

Regulatory Position	Position Number	Conformance	Remarks
spurious actuations occurring in rapid succession (without sufficient time to mitigate the consequences) have a relatively high probability of occurring. The success path SSCs, including circuits, must be protected from fire damage that could prevent safe shutdown.			
Appendix R to 10 CFR 50 defines alternative shutdown capability as being provided by rerouting, relocating, or modifying existing systems, whereas dedicated shutdown is defined as being provided by installing <i>new</i> structures and systems for the function of post-fire shutdown. Since post-fire repairs cannot be credited for achieving and maintaining hot shutdown, the licensee should implement the required rerouting, relocating, or modifying of the existing system for alternative shutdown capability in existing plants when the need for additional alternative shutdown capability is identified.	5.4.1	N/A	The US-APWR is an evolutionary plant that complies with Position 8.2.
When alternative or dedicated shutdown systems are credited for achieving post-fire safe shutdown, a specific category of circuits has been defined (referred to as "associated circuits of concern") and acceptable approaches to mitigating the consequences of fire-induced failure of these circuits have been identified. These circuits are nonsafety or safety circuits that could adversely affect the identified shutdown equipment by feeding back potentially disabling conditions (e.g., hot shorts or shorts to ground) to power supplies or control circuits of that equipment and should be evaluated. Such disabling conditions should be prevented to provide assurance that the identified safe-shutdown equipment will function as designed.	5.4.2	N/A	The US-APWR is an evolutionary plant that complies with Position 8.2.
The shutdown capability may be protected from the adverse effect	5.4.3	N/A	See Position 5.3.
of damage to associated circuits of concern by the separation and protection guidelines of Regulatory Position 5.3 of this guide or, alternatively, by the following methods as applied to each type of associated circuit of concern.			

**Comanche Peak Nuclear Power Plant, Units 3 & 4
COL Application
Part 2, FSAR**

**Table 9.5.1-1R (Sheet 38 of 51)
CPNPP Units 3 & 4 Fire Protection Program Conformance with RG 1.189**

Regulatory Position	Position Number	Conformance	Remarks
A load fuse/breaker (i.e., interrupting devices) to feeder fuse/breaker coordination to prevent loss of the redundant or alternative shutdown power source may be necessary. IEEE Standard 242, "IEEE Recommended Practices for Protection and Coordination of Industrial and Commercial Power Systems," provides detailed guidance on achieving proper coordination.	5.4.3.1	N/A	See Position 5.3.
Spurious operation is considered mitigated if one of the following criteria are met: a. A means to isolate the equipment and components from the fire area before the fire (i.e., remove power, open circuit breakers) is provided. b. Electrical isolation that prevents spurious operation is provided. Potential isolation devices include breakers, fuses, amplifiers, control switches, current transformers, fiber optic couplers, relays, and transducers. c. A means to detect spurious operations and develop procedures to mitigate the maloperation of equipment (e.g., closure of the block valve if a power-operated relief valve spuriously operates, opening of the breakers to remove spurious operation of safety injection) is provided.	5.4.3.2	N/A	See Position 5.3.
Common Enclosures. Appropriate measures to prevent propagation of the fire should be provided. Electrical protection (e.g., breakers, fuses, or similar devices) should also be provided.	5.4.3.3	N/A	See Position 5.3.
The MCR fire area contains the controls and instruments for	5.4.4	Conform	The remote shutdown console
redundant shutdown systems in close proximity. (Separation is usually a few inches.) Remote shutdown capability for the MCR and its required circuits should be independent of the cables, systems, and components in the MCR fire area. The damage to systems in the MCR for a fire that causes evacuation of the MCR cannot be predicted. The licensee should conduct a bounding analysis to ensure that safe conditions can be maintained from outside the MCR.			located in a separate fire area from the MCR contains all controls necessary to safely achieve cold shutdown. When this remote console is used, MCR circuits are defeated so no adverse fire impact on safe-shutdown capability results.

**Comanche Peak Nuclear Power Plant, Units 3 & 4
COL Application
Part 2, FSAR**

**Table 9.5.1-1R (Sheet 39 of 51)
CPNPP Units 3 & 4 Fire Protection Program Conformance with RG 1.189**

Regulatory Position	Position Number	Conformance	Remarks	
CP COL 9.5(1)	<p>Procedures for effecting safe shutdown should reflect the results and conclusions of the safe shutdown analysis. Implementation of the procedures should not further degrade plant safety functions. Time-critical operations for effecting safe shutdown identified in the safe-shutdown analysis and incorporated in post-fire procedures should be validated.</p>	5.5	Conform	See Subsection 9.5.1.6.
	<p>Post-fire safe-shutdown operating procedures should be developed for those areas where alternative or dedicated shutdown is required. For other areas of the plant, shutdown would normally be achieved using the normal operating procedures or plant emergency operating procedures.</p>	5.5.1	N/A	The US-APWR is an evolutionary plant that complies with Position 8.2.
CP COL 9.5(1)	<p>Procedures should be in effect that describe the tasks to implement remote shutdown capability when offsite power is available and when offsite power is not available for 72 hours. These procedures should also address necessary actions to compensate for spurious operations and high-impedance faults if such actions are necessary to effect safe shutdown.</p>	5.5.2	Conform	See Subsection 9.5.1.6.
	<p>The licensee should develop procedures for performance of repairs necessary to achieve and maintain cold shutdown conditions. For alternative shutdown,</p>	5.5.3	N/A	Repairs are not required to achieve cold shutdown. Cold shutdown is achieved through
	<p>procedures should be in effect to accomplish repairs necessary to achieve and maintain cold shutdown within 72 hours. For plants that must proceed to cold shutdown prior to 72 hours, the procedures should support the required time for initiation of cold shutdown.</p>			redundant safety trains of equipment through normal operating procedures.

**Comanche Peak Nuclear Power Plant, Units 3 & 4
COL Application
Part 2, FSAR**

**Table 9.5.1-1R (Sheet 40 of 51)
CPNPP Units 3 & 4 Fire Protection Program Conformance with RG 1.189**

Regulatory Position	Position Number	Conformance	Remarks	
CP COL 9.5(1)	Safe-shutdown requirements and objectives are focused on achieving shutdown conditions for fires occurring during normal at-power operations. During shutdown operations (i.e., maintenance or refueling outages), fire risk may increase significantly as a result of work activities. In addition, redundant systems important to safety may not be available as allowed by plant technical specifications and plant procedures. The fire protection program should be reviewed to verify that fire protection systems, features, and procedures will minimize the potential for fire events to impact safety functions (e.g., reactivity control, reactor decay heat removal, spent fuel pool cooling) or result in the unacceptable release of radioactive materials, under the differing conditions that may be present during shutdown operations.	5.6	Conform	See Subsection 9.5.1.6.
	Several areas within a nuclear power plant present unique hazards or design issues relative to fire protection and safe shutdown. This section provides guidance applicable to specific plant areas.	6.	N/A	Informational statement.
	Fire protection for the primary and secondary containment areas should be provided for the hazards identified in the fire hazards analysis. Under normal conditions, containment fire hazards may include lubricating oils, hydraulic fluids, cables, electrical penetrations, electrical cabinets, and charcoal filters. During	6.1.1	Conform	Containment standpipe supplied to support fire suppression during outages.
	refueling and maintenance operations, additional hazards may be introduced, including contamination control and decontamination materials and supplies, scaffolding, plastic sheathing, wood planking, chemicals, and hot work.			

**Comanche Peak Nuclear Power Plant, Units 3 & 4
COL Application
Part 2, FSAR**

**Table 9.5.1-1R (Sheet 41 of 51)
CPNPP Units 3 & 4 Fire Protection Program Conformance with RG 1.189**

Regulatory Position	Position Number	Conformance	Remarks
For secondary containment areas, cable fire hazards that could affect safety should be protected as described in Regulatory Position 4.1.3.3 of this guide. Inside non-inerted containments, one of the fire protection means specified in Regulatory Position 5.3, or one of the following, should be provided: a. Separation of cables and equipment and associated nonsafety circuits of redundant trains by a horizontal distance of more than 6.1 m (20 ft) with no intervening combustibles or fire hazards b. Installation of fire detectors and an automatic fire suppression system in the fire area c. Separation of cables and equipment and associated nonsafety circuits of redundant trains by a noncombustible radiant energy shield having a minimum fire rating of 30 minutes, as demonstrated by testing or analysis	6.1.1.1	Conform	
The licensee should provide fire suppression systems on the basis of a fire hazards analysis. During normal operations, containment is generally inaccessible and, therefore, fire protection should be provided by automatic fixed systems. Automatic fire suppression capability need not be provided in primary containment atmospheres that are inerted during normal operations. However, inerted containments should have manual firefighting capability, including standpipes, hose stations, and portable extinguishers, to provide protection during refueling and maintenance operations.	6.1.1.2	Conform	See FHA (Appendix 9A).
Fire detection systems should alarm and annunciate in the MCR. In primary containment, fire detection systems should be provided for each fire hazard. For primary and secondary containment, the type of detection used and the location of the detectors should be the most suitable for the particular type of fire hazard identified by the fire hazards analysis.	6.1.1.3	Conform	See Appendix 9A for specific discussion on type of detection for specific areas. A general coverage fire detection system is provided in containment.

**Comanche Peak Nuclear Power Plant, Units 3 & 4
COL Application
Part 2, FSAR**

**Table 9.5.1-1R (Sheet 42 of 51)
CPNPP Units 3 & 4 Fire Protection Program Conformance with RG 1.189**

Regulatory Position	Position Number	Conformance	Remarks
The MCR complex (including galleys and office spaces) should be protected against disabling fire damage and should be separated from other areas of the plant by floors, walls, and roof having minimum fire-resistance ratings of 3 hours. Peripheral rooms in the MCR complex should have automatic water suppression and should be separated from the MCR by noncombustible construction with a fire-resistance rating of 1 hour. Ventilation system openings between the MCR and peripheral rooms should have automatic smoke dampers that close upon operation of the fire detection or suppression system. If a gas extinguishing system is used for fire suppression, these dampers should be strong enough to support the pressure rise accompanying the agent discharge and seal tightly against infiltration of the agent into the MCR. Carbon dioxide total flooding systems are not acceptable for these areas.	6.1.2	Conform	The MCR staff areas are separated from the MCR by 1 hour fire rated partitions and protected by an automatic low pressure water mist sprinkler system. Automatic fire detection is provided. A very early warning fire detection system is provided in raised-floor compartments and MCR cabinets. The MCR raised-floor compartment is also provided with an automatic fire suppression system that discharges an environmentally friendly clean fire extinguishing agent that does not present a hazard to MCR personnel. 3-hour fire rated separation is provide for the MCR complex No carbon dioxide systems are used in this area.
Manual firefighting capability should be provided for both of the following: a. fire originating within a cabinet, console, or connecting cables b. exposure fires involving	6.1.2.1	Conform	A fire hose station is located in the corridor immediately outside the entrance to the MCR. The
combustibles in the general room area Portable Class A and Class C fire extinguishers should be located in the MCR. A hose station should be installed inside or immediately outside the MCR.			appropriate portable extinguishers are located within the MCR.

**Comanche Peak Nuclear Power Plant, Units 3 & 4
COL Application
Part 2, FSAR**

**Table 9.5.1-1R (Sheet 43 of 51)
CPNPP Units 3 & 4 Fire Protection Program Conformance with RG 1.189**

Regulatory Position	Position Number	Conformance	Remarks
Smoke detectors should be provided in the MCR, cabinets, and consoles. If redundant safe-shutdown equipment is located in the same MCR cabinet or console, additional fire protection measures should be provided. Alarm and local indication should be provided in the MCR. The outside air intake(s) for the MCR ventilation system should be provided with smoke detection capability to alarm in the MCR to enable manual isolation of the MCR ventilation system and, thus, prevent smoke from entering the MCR.	6.1.2.2	Conform	The US-APWR utilizes a very early warning smoke detection system (air aspirating) within the raised-floor area that also senses within the MCR console and cabinets. Intake air is sampled by smoke detection to alarm and allow manual isolation.
Venting of smoke produced by fire in the MCR by means of the normal ventilation system is acceptable; however, provision should be made to permit isolation of the recirculating portion of the normal ventilation system. Manually operated venting of the MCR should be available to the operators.	6.1.2.3	Conform	MCR smoke removal is provided by design. The smoke removal function is manually activated by MCR operators.
A separate cable spreading room should be provided for each redundant division. Cable spreading rooms should not be shared between reactors. Each cable spreading room should be separated from the others and from other areas of the plant by barriers with a minimum fire rating of 3 hours. If this is not possible, an alternative, dedicated, or backup shutdown capability should be provided.	6.1.3	N/A	The US-APWR does not utilize a cable spreading room for the design. A raised-floor cable routing space is part of the fire zone separation, has automatic detection and suppression installed.
Computer rooms for computers performing functions important to safety that are not part of the MCR complex should be separated from other areas of the plant by barriers	6.1.4	Conform	
having a minimum fire-resistance rating of 3 hours and should be protected by automatic detection and fixed automatic suppression.			

**Comanche Peak Nuclear Power Plant, Units 3 & 4
COL Application
Part 2, FSAR**

**Table 9.5.1-1R (Sheet 44 of 51)
CPNPP Units 3 & 4 Fire Protection Program Conformance with RG 1.189**

Regulatory Position	Position Number	Conformance	Remarks
Switchgear rooms containing equipment important to safety should be separated from the remainder of the plant by barriers with a minimum fire rating of 3 hours. Redundant switchgear safety divisions should be separated from each other by barriers with a 3-hour fire rating. Automatic fire detectors should alarm and annunciate in the MCR and alarm locally. Cables entering the switchgear room that do not terminate or perform a function should be kept at a minimum to minimize the fire hazard. These rooms should not be used for any other purpose. Automatic fire suppression should be provided consistent with other safety considerations. Fire hose stations and portable fire extinguishers should be readily available outside the area.	6.1.5	Conform	system is provided in safety-related switchgear rooms, which is an appropriate fire suppression agent for electrical equipment that would not create system malfunction if inadvertently discharged.
Barriers having a minimum fire rating of 3 hours should separate panels providing remote shutdown capability from the MCR complex. Panels providing remote shutdown capability should be electrically isolated from the MCR complex so that a fire in either area will not affect shutdown capability from the other area. The general area housing remote panels important to safety should be provided with automatic fire detectors that alarm locally and alarm and annunciate in the MCR. Combustible materials should be controlled and limited to those required for operation. Portable extinguishers and manual hose stations should be readily available in the general area.	6.1.6	Conform	The remote shutdown console is located in a separate fire area on a plant level above the MCR complex and is in a room formed by 3-hour fire rated barriers.
Battery rooms important to safety should be protected against fires and explosions. Battery rooms should be separated from each other and other areas of the plant	6.1.7	Conform	Ventilation system prevents hydrogen gas buildup. System malfunction is alarmed.
by barriers having a minimum fire rating of 3 hours inclusive of all penetrations and openings.			

**Comanche Peak Nuclear Power Plant, Units 3 & 4
COL Application
Part 2, FSAR**

**Table 9.5.1-1R (Sheet 45 of 51)
CPNPP Units 3 & 4 Fire Protection Program Conformance with RG 1.189**

Regulatory Position	Position Number	Conformance	Remarks
	6.1.8	N/A	The US-APWR uses gas turbine generators for emergency power sources. Four safety-related gas turbine generators and the two SBO gas turbine generators are installed in individual fire areas with 3-hour fire rated barriers providing separation.
	6.1.9	Conform	Rooms have fire detection installed. Automatic suppression is not provided unless there is significant lube oil associated with the unit based upon the FHA (See Appendix 9A).
	6.2	Informational Statement	Other areas within the plant may contain hazards or equipment that warrant special consideration relative to fire protection, including areas containing significant quantities of radioactive materials, yard areas containing water supplies or systems important to safety, and the plant cooling tower.
CP COL 9.5(1)	6.2.1	Conform	New Fuel Areas. Portable hand extinguishers should be located near this area. In addition, hose stations should be located outside but within hose reach of this area. Automatic fire detection should alarm and annunciate in the MCR
			and alarm locally. Combustibles should be limited to a minimum in the new fuel area. The storage area should be provided with a drainage system to preclude accumulation of water.

**Comanche Peak Nuclear Power Plant, Units 3 & 4
COL Application
Part 2, FSAR**

**Table 9.5.1-1R (Sheet 46 of 51)
CPNPP Units 3 & 4 Fire Protection Program Conformance with RG 1.189**

Regulatory Position	Position Number	Conformance	Remarks
Spent Fuel Areas. Local hose stations and portable extinguishers should provide protection for the spent fuel pool. Automatic fire detection should alarm and annunciate in the MCR and to alarm locally.	6.2.2	Conform	
Radioactive waste buildings, storage areas, and decontamination areas should be separated from other areas of the plant by fire barriers having at least 3-hour ratings. Automatic sprinklers should be used in all areas where combustible materials are located. Alternatively, manual hose stations and portable extinguishers (handheld and large-wheeled units sized according to the hazards) are acceptable. Automatic fire detection should annunciate and alarm in the MCR and alarm locally. Ventilation systems in these areas should be capable of being isolated to prevent the release of radioactive materials to other areas or the environment. Water from firefighting activities should drain to liquid Radwaste collection systems.	6.2.3	Conform	
The requirements of 10 CFR 72.122(c) address fire protection of dry cask storage and other independent spent fuel storage facilities. The fire protection provided for these facilities should be commensurate with the potential fire hazards and with the potential for an unacceptable release of radiation during and following a fire. In addition to the requirements of 10 CFR 72, "Licensing Requirements for the Independent Storage of Spent Nuclear Fuel, High-Level Radioactive Waste, and Reactor-	6.2.4	N/A	Dry Cask storage is not a feature required for The US-APWR plant.
Related Greater Than Class C Waste," fire protection for independent spent fuel storage installations should ensure that fires involving such installations will not impact plant operations and plant areas important to safety.			
Storage tanks that supply water for safe shutdown should be protected from the effects of an exposure fire. Combustible materials should not be stored next to outdoor tanks.	6.2.5	Conform	RWSP is internal to R/B and isolated from damage by a fire. Auxiliary feed water storage in within plant separated by 3-hour fire barriers.

**Comanche Peak Nuclear Power Plant, Units 3 & 4
COL Application
Part 2, FSAR**

**Table 9.5.1-1R (Sheet 47 of 51)
CPNPP Units 3 & 4 Fire Protection Program Conformance with RG 1.189**

Regulatory Position	Position Number	Conformance	Remarks
CP COL 9.5(2)	6.2.6	Conform	Cooling towers for the CPNPP ultimate heat sink are of non-combustible construction.
	7.1	Conform	A compliant oil leakage collection system is provided for RCPs.
	7.2	Conform	The R/B wall separating the R/B from the T/B areas meets 3-hour fire resistive construction requirements.
			structure. Openings and penetrations in the fire barrier should be minimized and should not be located where the turbine oil system or generator hydrogen cooling system creates a direct fire exposure hazard to the barrier.
	7.2.1	Conform	There is no safety-related equipment in the T/B. The T/B is separated from the R/B by 3-hour barriers. Individual hazards within the T/B are separated based on the US-APWR FHA (Appendix 9A).

**Comanche Peak Nuclear Power Plant, Units 3 & 4
COL Application
Part 2, FSAR**

**Table 9.5.1-1R (Sheet 48 of 51)
CPNPP Units 3 & 4 Fire Protection Program Conformance with RG 1.189**

	Regulatory Position	Position Number	Conformance	Remarks
CP COL 9.5(2)	Turbine generators may use hydrogen for cooling. Hydrogen storage and distribution systems should meet the guidelines provided in Regulatory Position 7.5 of this guide.	7.2.2	Conform	
	Smoke control should be provided in the T/B to mitigate potential heavy smoke conditions associated with combustible liquid and cable fires. Regulatory Position 4.1.4 provides specific guidance.	7.2.3	Conform	Smoke vents in T/B roof.
CP COL 9.5(2)	Transformers installed inside fire areas containing systems important to safety should be of the dry type or insulated and cooled with noncombustible liquid. Transformers filled with combustible fluid that are located indoors should be enclosed in a transformer vault. NFPA 70 offers additional guidance. Outdoor oil-filled transformers should have oil spill confinement features or drainage away from the buildings. Such transformers should be located at least 15.2 m (50 ft) distant from the building, or building walls within 15.2 m (50 ft) of oil-filled transformers should be without openings and have a fire resistance rating of at least 3 hours.	7.3	Conform	Transformers installed inside fire areas containing systems important to safety are the dry type. Outdoor oil-filled transformers are separated from turbine building by a 3-hour fire barrier. See Subsection 9.5.1.2.1.
CP COL 9.5(2)	Bulk gas storage (either compressed or cryogenic) should not be permitted inside structures housing equipment important to safety. Storage of flammable gas such as hydrogen should be located outdoors or in separate, detached buildings so that a fire or explosion will not adversely affect any systems or equipment important to safety.	7.5	Conform	Bulk gas storage is located in yard area away from safety-related plant structures.
CP COL 9.5(2)	The fire protection program should address plant support facilities (e.g., offices, maintenance shops, warehouses, temporary structures, equipment storage yards), collocated power generating units (e.g., nuclear, coal, natural gas), and nearby industrial facilities (e.g., chemical plants, refineries, manufacturing facilities) to the extent that fires and or explosions in these facilities may affect equipment important to safety. Fire protection systems and features should be adequate to protect against potential exposure fires and explosions from nearby facilities.	7.6	Conform	Plant support facilities are located away from safety-related plant structures.

**Comanche Peak Nuclear Power Plant, Units 3 & 4
COL Application
Part 2, FSAR**

**Table 9.5.1-1R (Sheet 49 of 51)
CPNPP Units 3 & 4 Fire Protection Program Conformance with RG 1.189**

Regulatory Position	Position Number	Conformance	Remarks
Many of the current fire protection requirements and guidelines for operating reactors were issued after Commission approval of construction permits and/or operating licenses. The backfit of these requirements and guidelines to existing plant designs created the need for considerable flexibility in the application of the regulations on a plant-by-plant basis. New reactor designs should integrate fire protection requirements, including the protection of safe-shutdown capability and the prevention of radiological release, into the planning and design phase for the plant.	8.1	Conform	As an advanced nuclear plant, the US-APWR has integrated fire protection requirements into the planning and design phases of the plant.
New reactor designs should ensure that safe-shutdown can be achieved assuming that all equipment in any one fire area will be rendered inoperable by fire and that reentry into the fire area for	8.2	Conform	The US-APWR meets the enhanced fire protection provisions of SECY-93-087 as
repairs and operator actions is not possible. Because of its physical configuration, the MCR is excluded from this approach, provided the design includes an independent alternative shutdown capability that is physically and electrically independent of the MCR. The MCR should be evaluated to ensure that the effects of fire do not adversely affect the ability to achieve and maintain safe shutdown. New reactors should provide fire protection for redundant shutdown systems in the reactor containment building that will ensure, to the extent practicable, that one shutdown division will be free of fire damage. Additionally, new reactor designs should ensure that smoke, hot gases, or the fire suppressant will not migrate into other fire areas to the extent that they could adversely affect safe shutdown capabilities, including operator actions.			demonstrated in the FHA (Appendix 9A).

**Comanche Peak Nuclear Power Plant, Units 3 & 4
COL Application
Part 2, FSAR**

**Table 9.5.1-1R (Sheet 50 of 51)
CPNPP Units 3 & 4 Fire Protection Program Conformance with RG 1.189**

Regulatory Position	Position Number	Conformance	Remarks
As discussed in SECY-94-084, the definitions of safe shutdown contained in the Commission's regulations and guidelines do not address the inherent limitations of passive RHR systems. Based on the discussion and recommendations of SECY-94-084, the passive decay heat removal systems must be capable of achieving and maintaining 215.6 °C (420 °F) or below for non-LOCA events. This safe-shutdown condition is predicated on demonstration of acceptable passive safety system performance.	8.3	N/A	The US-APWR plant uses four redundant active safety-related trains including the RHR systems to achieve cold shutdown in the event of a fire requiring plant shutdown within one of the safety-related trains.
In general, the fire protection program for new light-water reactor designs should comply with the provisions specified in NFPA 804, "Standard for Fire Protection for Advanced Light-Water Reactor Electric Generating Plants," as they relate to the protection of post-fire safe-shutdown capability and the mitigation of a radiological release resulting from a fire. However, the NRC has not formally endorsed NFPA 804 and some of the guidance in the NFPA standard conflicts with regulatory requirements. When conflicts occur, the applicable regulatory requirements and guidance, including the guidance in this RG, will govern.	8.4	Conform	The US-APWR conforms to the requirements of NFPA 804 except where requirements of RG-1.189 conflicts. See table 9.2-2 for an item by item comparison with the requirements of NFPA 804.
Fire protection programs for proposed new non-light-water reactor designs should meet the overall fire protection objectives and guidance provided in the applicable regulations and this RG as they relate to safe shutdown and radiological release, as well as the specific fire protection requirements, as applicable.	8.5	N/A	The US-APWR is light-water reactor.

**Comanche Peak Nuclear Power Plant, Units 3 & 4
COL Application
Part 2, FSAR**

**Table 9.5.1-1R (Sheet 51 of 51)
CPNPP Units 3 & 4 Fire Protection Program Conformance with RG 1.189**

	Regulatory Position	Position Number	Conformance	Remarks
CP COL 9.5(1)	SECY-05-0197, "Review of Operational Programs in a Combined License Application and Generic Emergency Planning Inspections, Tests, Analyses, and Acceptance Criteria," identifies fire protection as an "operation program." However, only those elements of the fire protection program that will not be implemented fully until the completion of the plant should be addressed as an operational program. This may include, but is not be limited to, the fire brigade, combustible and ignition source control program, procedures and prefire plans, and portable extinguishing equipment. The COL application should identify the operational program aspects of the fire protection program and the implementation schedule for each. In lieu of the implementation schedule, the applicant may propose inspections, tests, analyses, and acceptance criteria for these aspects of the program.	8.6	Conform	See Subsection 9.5.1.6.
CP COL 9.5(1)	NRC regulations and guidance do not specifically address fire protection during nonpower modes of plant operation (e.g., during shutdown for maintenance and/or	8.7	Conform	See Subsection 9.5.1.6.
	refueling) except for existing plants that adopt an NFPA 805 fire protection program. However, the requirements for fire prevention in Regulatory Position 2 of this guide apply to all modes of plant operation, including shutdown. License applications for new reactors should also address any special provisions to ensure that, in the event of a fire during a nonpower mode of operation, the plant can be maintained in safe shutdown.			
	Licensees may apply for a license renewal to permit continued plant operation beyond the original operating license period of operation, in accordance with the provisions of 10 CFR 54. The fire protection licensing and design basis under license renewal should not differ significantly from that in effect before renewal with the exception that fire protection SSCs must be included in an aging management program as appropriate.	9.	N/A	The US-APWR is a new plant that will obtain an initial operating license. The design life of US-APWR is sixty years.

**Comanche Peak Nuclear Power Plant, Units 3 & 4
COL Application
Part 2, FSAR**

**Table 9.5.1-2R (Sheet 1 of 70)
CPNPP Units 3 & 4 Fire Protection Program Conformance with NFPA 804**

Standard Requirement	Paragraph	Conformance	Remarks	
CP COL 9.5(1)	All elements of the site fire protection program shall be reviewed every 2 years and updated as necessary.	4.1.1	Conform	See Subsection 9.5.1.6.
CP COL 9.5(1)	Other review frequencies shall be permitted where specified in site administrative procedures and approved by the authority having jurisdiction.	4.1.2	N/A	CPNPP uses a two year cycle
CP COL 9.5(1)	A policy document shall be prepared that defines management authorities and responsibilities and establishes the general policy for the site fire protection program.	4.2.1	Conform	See Subsection 9.5.1.6.
CP COL 9.5(1)	The policy document shall designate the senior management person with immediate authority and responsibility for the fire protection program.	4.2.2	Conform	See Subsection 9.5.1.6.
CP COL 9.5(1)	The policy document shall define the fire protection interfaces with other organizations and assign responsibilities for the coordination activities.	4.2.3	Conform	See Subsection 9.5.1.6.
CP COL 9.5(1)	The policy document shall include the authority for conflict resolution.	4.2.4	Conform	See Subsection 9.5.1.6.
CP COL 9.5(1)	A fire prevention program shall be established and documented to include all of the following: (1) Fire safety information for all employees and contractors, including as a minimum familiarization with plant fire prevention procedures, fire reporting, and plant emergency alarms, including evacuation. (2) Documented plant inspections, including provisions for handling of remedial actions to correct conditions that increase fire hazards. (3) Procedures for the control of general housekeeping practices and the control of transient combustibles. (4) Procedures for the control of flammable and combustible gases in accordance with NFPA standards.	4.3	Conform	See Subsection 9.5.1.6.

**Comanche Peak Nuclear Power Plant, Units 3 & 4
COL Application
Part 2, FSAR**

**Table 9.5.1-2R (Sheet 2 of 70)
CPNPP Units 3 & 4 Fire Protection Program Conformance with NFPA 804**

Standard Requirement	Paragraph	Conformance	Remarks	
			(5) Procedures for the control of ignition sources, such as smoking, welding, cutting, and grinding (see NFPA 51B, Standard for Fire Prevention During Welding, Cutting, and Other Hot Work). (6) Fire prevention surveillance plan (see NFPA 601, <i>Standard for Security Services in Fire Loss Prevention</i>). (7) Fire-reporting procedure, including investigation requirements and corrective action requirements.	
CP COL 9.5(2)	A documented fire hazards analysis shall be made for each site.	4.4.1	Conform	See Appendix 9A.
CP COL 9.5(2)	The analysis shall document all of the following: (1) Physical construction and layout of the buildings and equipment, including fire areas and the fire ratings of area boundaries. (2)* Inventory of the principal combustibles within each fire subdivision. (3) Description of the fire protection equipment, including alarm systems and manual and automatic extinguishing systems. (4) Description and location of any equipment necessary to ensure a safe shutdown, including cabling and piping between equipment. (5) Analysis of the postulated fire in each fire area, including its effect on safe shutdown equipment, assuming automatic and manual fire protection equipment do not function. (6) Analysis of the potential effects of a fire on life safety, release of contamination, impairment of operations, and property loss, assuming the operation of installed fire-extinguishing equipment. (7) Analysis of the potential effects of other hazards, such as earthquakes, storms, and floods, on fire protection. (8) Analysis of the potential effects of an uncontained fire in causing other problems not related to safe shutdown, such as a release of	4.4.2	Conform	See Appendix 9A.

**Comanche Peak Nuclear Power Plant, Units 3 & 4
COL Application
Part 2, FSAR**

**Table 9.5.1-2R (Sheet 3 of 70)
CPNPP Units 3 & 4 Fire Protection Program Conformance with NFPA 804**

Standard Requirement	Paragraph	Conformance	Remarks
<p>contamination and impairment of operations. (9) Analysis of the postfire recovery potential. (10) Analysis for the protection of nuclear safety-related systems and components from the inadvertent actuation or breaks in a FPS. (11) Analysis of the smoke control system and the impact smoke can have on nuclear safety and operation for each fire area. (12) Analysis of the emergency planning and coordination requirements necessary for effective loss control, including any necessary compensatory measures to compensate for the failure or inoperability of any active or passive fire protection system or feature.</p>			
<p>CP COL 9.5(1) A formal procedure system for all actions pertaining to the fire protection program shall be established, including all of the following: (1) Inspection, testing, maintenance, and operation of fire protection systems and equipment, both manual and automatic, such as detection and suppression systems. (2) Inspection, testing, and maintenance of passive fire protection features, such as fire barriers and penetration seals. (3) Trend analysis requirements. (4) Provisions for entering areas with access restrictions. (5) Training requirements.</p>	4.5	Conform	See Subsection 9.5.1.6.
<p>CP COL 9.5(1) A quality assurance program shall be established in accordance with ASME NQA-1, Quality Assurance Program Requirements for Nuclear Facilities, for all of the following aspects of the fire protection program related to nuclear safety: (1) Design and procurement document control. (2)* Instructions, procedures, and drawings. (3)* Control of purchased material, equipment, and services. (4)* Inspection.</p>	4.6.1	Conform	See Chapter 17 and Subsection 9.5.1.6.

**Comanche Peak Nuclear Power Plant, Units 3 & 4
COL Application
Part 2, FSAR**

**Table 9.5.1-2R (Sheet 4 of 70)
CPNPP Units 3 & 4 Fire Protection Program Conformance with NFPA 804**

Standard Requirement	Paragraph	Conformance	Remarks
			(5)* Test and test control. (6)* Inspection, test, and operating status. (7)* Nonconforming items. (8)* Corrective action. (9)* Records. (10)* Audits.
CP COL 9.5(1)	4.6.2	Conform	See Chapter 17 and Subsection 9.5.1.6.
CP COL 9.5(1)	4.7.1	Conform	See Subsection 9.5.1.6.
CP COL 9.5(1)	4.7.2	Conform	See Subsection 9.5.1.6.
			As a minimum, this plan shall include the following: (1) Response to fire and supervisory alarms. (2) Notification of plant and public emergency forces. (3) Evacuation of personnel. (4) Coordination with security, maintenance, operations, and public information personnel. (5) Fire extinguishment activities. (6) Postfire recovery and contamination control activities. (7) Control room operations during an emergency. (8) Prefire plan. (9) Description of interfaces with emergency response organizations, security, safety, and others having a role in the fire protection program, including agreements with outside assistance agencies, such as fire departments and rescue services.
CP COL 9.5(1)	4.8	Conform	See Subsection 9.5.1.6.
CP COL 9.5(1)	5.2.1	Conform	See Subsection 9.5.1.6.
CP COL 9.5(1)	5.2.2	Conform	See Subsection 9.5.1.6.
CP COL 9.5(1)	5.2.3	Conform	See Subsection 9.5.1.6.

**Comanche Peak Nuclear Power Plant, Units 3 & 4
COL Application
Part 2, FSAR**

**Table 9.5.1-2R (Sheet 5 of 70)
CPNPP Units 3 & 4 Fire Protection Program Conformance with NFPA 804**

Standard Requirement	Paragraph	Conformance	Remarks	
CP COL 9.5(1)	Areas of primary containment and high-radiation areas normally inaccessible during plant operation shall be inspected as plant conditions permit but at least during each refueling outage.	5.2.4	Conform	See Subsection 9.5.1.6.
CP COL 9.5(1)	The results of each inspection shall be documented and retained for 2 years.	5.2.5	Conform	See Subsection 9.5.1.6.
CP COL 9.5(1)	For those plant areas inaccessible for periods greater than 2 years, the most recent inspection shall be retained.	5.2.5.1	Conform	See Subsection 9.5.1.6.
CP COL 9.5(1)	Plant administrative procedures shall specify appropriate requirements governing the storage, use, and handling of flammable and combustible liquids and flammable gases.	5.3.1	Conform	See Subsection 9.5.1.6.
CP COL 9.5(1)	An inventory of all temporary flammable and combustible materials shall be made for each fire area, identifying the location, type, quantity, and form of the materials.	5.3.1.1	Conform	.
	Temporary but predictable and repetitive concentrations of flammable and combustible materials shall be considered.	5.3.1.2	Conform	
CP COL 9.5(1)	Combustibles, other than those that are an inherent part of the operation, shall be restricted to designated storage compartments or spaces.	5.3.1.3	Conform	
CP COL 9.5(1)	Consideration shall be given to reducing the fire hazard by limiting the amount of combustible materials.	5.3.1.4	Conform	
CP COL 9.5(2)	The storage and use of hydrogen shall be in accordance with NFPA 55, Standard for the Storage, Use, and Handling of Compressed Gases and Cryogenic Fluids in Portable and Stationary Containers, Cylinders, and Tanks	5.3.1.5	Conform	See Subsection 9.5.1.6.
CP COL 9.5(1)	The temporary use of wood shall be minimized.	5.3.1.6	Conform	See Subsection 9.5.1.6.

**Comanche Peak Nuclear Power Plant, Units 3 & 4
COL Application
Part 2, FSAR**

**Table 9.5.1-2R (Sheet 6 of 70)
CPNPP Units 3 & 4 Fire Protection Program Conformance with NFPA 804**

Standard Requirement	Paragraph	Conformance	Remarks	
CP COL 9.5(1)	Plant administrative procedures shall specify that if wood must be used in the power block, it shall be listed pressure-impregnated fire-retardant lumber.	5.3.1.7	Conform	See Subsection 9.5.1.6.
CP COL 9.5(1)	Housekeeping shall be performed in such a manner as to minimize the probability of fire.	5.3.2.1	Conform	See Subsection 9.5.1.6.
CP COL 9.5(1)	Accumulations of combustible waste material, dust, and debris shall be removed from the plant and its immediate vicinity at the end of each work shift or more frequently as necessary for safe operations.	5.3.2.2	Conform	See Subsection 9.5.1.6.
CP COL 9.5(1)	Plant administrative procedures shall require the following: (1) The total fire loads, including temporary and permanent combustible loading, shall not exceed those quantities established for extinguishment by permanently installed fire protection systems and equipment. (2) Where limits are temporarily exceeded, the plant fire protection manager shall ensure that appropriate fire protection measures are provided.	5.3.3.1	Conform	See Subsection 9.5.1.6.
CP COL 9.5(1)	The fire protection manager or a designated representative shall conduct weekly walk-through inspections to ensure implementation of required controls.	5.3.3.2	Conform	
CP COL 9.5(1)	During major maintenance operations, the frequency of these walk-throughs shall be increased to daily.	5.3.3.2.1	Conform	
CP COL 9.5(1)	The results of these inspections shall be documented and the documentation retained for a minimum of 2 years.	5.3.3.2.2	Conform	See Subsection 9.5.1.6.
CP COL 9.5(1)	When the work is completed, the plant fire protection manager shall have the area inspected to confirm that transient combustible loadings have been removed from the area.	5.3.3.3	Conform	See Subsection 9.5.1.6.
CP COL 9.5(1)	Extra equipment shall then be returned to its proper location.	5.3.3.3.1	Conform	See Subsection 9.5.1.6.
CP COL 9.5(1)	The results of this inspection shall be documented and retained for 2 years.	5.3.3.3.2	Conform	See Subsection 9.5.1.6.
CP COL 9.5(1)				

**Comanche Peak Nuclear Power Plant, Units 3 & 4
COL Application
Part 2, FSAR**

**Table 9.5.1-2R (Sheet 7 of 70)
CPNPP Units 3 & 4 Fire Protection Program Conformance with NFPA 804**

Standard Requirement	Paragraph	Conformance	Remarks
	5.3.3.4	Conform	See Subsection 9.5.1.6.
CP COL 9.5(1)	5.3.3.5	Conform	
CP COL 9.5(1)	5.3.4.1	Conform	
	5.3.4.2	Conform	
	5.3.4.3	Conform	
	5.3.4.4	Conform	
	5.3.4.5	Conform	

**Comanche Peak Nuclear Power Plant, Units 3 & 4
COL Application
Part 2, FSAR**

**Table 9.5.1-2R (Sheet 8 of 70)
CPNPP Units 3 & 4 Fire Protection Program Conformance with NFPA 804**

Standard Requirement	Paragraph	Conformance	Remarks
	5.3.4.6	Conform	
CP COL 9.5(1)	5.4.1.1	Conform	See Subsection 9.5.1.6.
CP COL 9.5(1)	5.4.1.2	Conform	See Subsection 9.5.1.6.
CP COL 9.5(1)	5.4.2.2	Conform	
CP COL 9.5(1)	5.4.2.3	Conform	
CP COL 9.5(1)	5.4.2.4	Conform	
CP COL 9.5(1)	5.4.3.1	Conform	See Subsection 9.5.1.6.

**Comanche Peak Nuclear Power Plant, Units 3 & 4
COL Application
Part 2, FSAR**

**Table 9.5.1-2R (Sheet 9 of 70)
CPNPP Units 3 & 4 Fire Protection Program Conformance with NFPA 804**

	Standard Requirement	Paragraph	Conformance	Remarks
CP COL 9.5(1)	"No Smoking" signs shall be posted in the areas specified in 5.4.3.1.	5.4.3.2	Conform	
CP COL 9.5(1)	Smoking shall be permitted only in designated and supervised safe areas of the plant.	5.4.3.3	Conform	
CP COL 9.5(1)	Where smoking is permitted, safe receptacles shall be provided for smoking materials.	5.4.3.4	Conform	
CP COL 9.5(1)	All temporary electrical wiring shall comply with the following to minimize the ignition of flammable materials: (1) Be kept to a minimum. (2) Be suitable for the location. (3) Be installed and maintained in accordance with NFPA 70, National Electrical Code, or ANSI/IEEE C2, National Electrical Safety Code, as appropriate. (4) Be arranged so that energy shall be isolated by a single switch. (5) Be arranged so that energy shall be isolated when not needed.	5.4.4	Conform	
CP COL 9.5(1)	Only safely installed, approved heating devices shall be used in all locations.	5.4.5.1	Conform	
CP COL 9.5(1)	Ample clearance shall be provided around stoves, heaters, and all chimney and vent connectors to prevent ignition of adjacent combustible materials in accordance with NFPA 211, Standard for Chimneys, Fireplaces, Vents, and Solid Fuel-Burning Appliances (connectors and solid fuel); NFPA 54, National Fuel Gas Code (fuel gas appliances); and NFPA 31, Standard for the Installation of Oil-Burning Equipment (liquid fuel appliances).	5.4.5.2	Conform	
CP COL 9.5(1)	Refueling operations of heating equipment shall be conducted in an approved manner.	5.4.5.3	Conform	
CP COL 9.5(1)	Heating devices shall be situated so that they are not likely to overturn.	5.4.5.4	Conform	
CP COL 9.5(1)	Temporary heating equipment, when utilized, shall be monitored and maintained by properly trained personnel.	5.4.5.5	Conform	
	Open-flame or combustion-generated smoke shall not be used for leak testing.	5.4.6	Conform	See Subsection 9.5.1.6.

**Comanche Peak Nuclear Power Plant, Units 3 & 4
COL Application
Part 2, FSAR**

**Table 9.5.1-2R (Sheet 10 of 70)
CPNPP Units 3 & 4 Fire Protection Program Conformance with NFPA 804**

Standard Requirement	Paragraph	Conformance	Remarks	
CP COL 9.5(1)	Plant administrative procedures shall specify appropriate requirements governing the control of electrical appliances in all plant areas.	5.4.7	Conform	
CP COL 9.5(1)	Temporary buildings, trailers, and sheds, whether individual or grouped, shall be constructed of noncombustible material and shall be separated from other structures.	5.5.1.1	Conform	
CP COL 9.5(1)	Temporary buildings, trailers, and sheds and other structures constructed of combustible or limited-combustible material shall be separated from other structures by a minimum distance of 30 ft., unless otherwise permitted by 5.5.1.3.	5.5.1.2	Conform	
CP COL 9.5(1)	Where all portions of the exposed building (walls, roof) within 30 ft. of the exposure constitute a rated fire barrier, the minimum separation distance shall be permitted to be reduced in accordance with Table 5.5.1.3.	5.5.1.3	Conform	
CP COL 9.5(1)	All exterior buildings, trailers, sheds, and other structures shall have the appropriate type and size of portable fire extinguishers.	5.5.1.4	Conform	
CP COL 9.5(1)	Where coverings are utilized for protection of the outdoor storage of materials or equipment, the following shall apply: (1) Only approved fire-retardant tarpaulins or other acceptable materials shall be used. (2) All framing material used to support such coverings shall be either noncombustible or fire-retardant pressure-impregnated wood. (3) Covered storage shall not be located within 30 ft. of any building.	5.5.2	Conform	
CP COL 9.5(1)	All interior temporary structures shall be constructed of noncombustible, limited-combustible, or fire-retardant pressure-impregnated wood.	5.5.3.1	Conform	See Subsection 9.5.1.6.
CP COL 9.5(1)	Structures constructed of noncombustible or limited-combustible materials shall be protected by an automatic fire suppression system unless the fire hazard analysis determines that automatic suppression is not required.	5.5.3.1.1	Conform	See Subsection 9.5.1.6.

**Comanche Peak Nuclear Power Plant, Units 3 & 4
COL Application
Part 2, FSAR**

**Table 9.5.1-2R (Sheet 11 of 70)
CPNPP Units 3 & 4 Fire Protection Program Conformance with NFPA 804**

Standard Requirement	Paragraph	Conformance	Remarks	
CP COL 9.5(1)	The structure shall be protected by an automatic fire suppression system if the structure is constructed of fire-retardant pressure-impregnated wood.	5.5.3.1.2	Conform	See Subsection 9.5.1.6.
CP COL 9.5(1)	The use of interior temporary coverings shall comply with the following criteria: (1) Be limited to special conditions where interior temporary coverings are necessary. (2) Be constructed of approved fire-retardant tarpaulins.	5.5.3.2	Conform	See Subsection 9.5.1.6.
CP COL 9.5(1)	Where framing is required, it shall be constructed of noncombustible, limited-combustible, or fire-retardant pressure-impregnated wood.	5.5.3.3	Conform	See Subsection 9.5.1.6.
CP COL 9.5(1)	All interior temporary facilities shall have the appropriate type and size of portable fire extinguisher.	5.5.3.4	Conform	See Subsection 9.5.1.6.
CP COL 9.5(1)	A written procedure shall be established to address impairments to fire protection systems and features and other plant systems that directly affect the level of fire risk (e.g., ventilation systems, plant emergency communication systems).	5.6.1	Conform	
CP COL 9.5(1)	Impairments to fire protection systems shall be as short in duration as practical.	5.6.2	Conform	
CP COL 9.5(1)	Appropriate post maintenance testing shall be performed on equipment that was impaired to ensure that the system will function properly.	5.6.3	Conform	
CP COL 9.5(1)	Any change to the design or function of the system after the impairment shall be considered in establishing the testing requirements and shall be reflected in the appropriate design documents and plant procedures.	5.6.4	Conform	
CP COL 9.5(1)	Upon installation, all new fire protection systems and passive fire protection features shall be preoperationally inspected and tested in accordance with applicable NFPA standards.	5.7.1	Conform	
CP COL 9.5(1)	Where appropriate test standards do not exist, inspections and test procedures described in the purchase and design specification shall be followed.	5.7.2	Conform	

**Comanche Peak Nuclear Power Plant, Units 3 & 4
COL Application
Part 2, FSAR**

**Table 9.5.1-2R (Sheet 12 of 70)
CPNPP Units 3 & 4 Fire Protection Program Conformance with NFPA 804**

Standard Requirement	Paragraph	Conformance	Remarks	
CP COL 9.5(1)	Fire protection systems and passive fire protection features shall be inspected, tested, and maintained in accordance with applicable NFPA standards, manufacturers' recommendations, and requirements established by those responsible for fire protection at the plant.	5.7.3	Conform	
CP COL 9.5(1)	Inspection, testing, and maintenance shall be performed using established procedures with written documentation of results and a program of follow-up actions on discrepancies.	5.7.4	Conform	
CP COL 9.5(1)	Consideration shall be given to the inspection, testing, and maintenance of nonfire protection systems and equipment that have a direct impact on the level of fire risk within the plant.	5.7.5	Conform	
CP COL 9.5(1)	Detailed prefire plans shall be developed for all site areas.	6.1.1	Conform	
CP COL 9.5(1)	Prefire plans shall detail the fire area configurations and fire hazards to be encountered in the fire area along with any safety-related components and fire protection systems and features that are present.	6.1.2	Conform	
CP COL 9.5(1)	Prefire plans shall be reviewed and, if necessary, updated at least every 2 years.	6.1.3	Conform	
CP COL 9.5(1)	Prefire plans shall be available in the control room and made available to the plant fire brigade.	6.1.4	Conform	
CP COL 9.5(1)	A minimum of five plant fire brigade members shall be available for response at all times.	6.2.1.1	Conform	See Subsection 9.5.1.6.
CP COL 9.5(1)	Fire brigade members shall have no other assigned normal plant duties that would prevent immediate response to a fire or other emergency as required.	6.2.1.2	Conform	See Subsection 9.5.1.6.

**Comanche Peak Nuclear Power Plant, Units 3 & 4
COL Application
Part 2, FSAR**

**Table 9.5.1-2R (Sheet 13 of 70)
CPNPP Units 3 & 4 Fire Protection Program Conformance with NFPA 804**

Standard Requirement	Paragraph	Conformance	Remarks	
CP COL 9.5(1)	The brigade leader and at least two brigade members shall have training and knowledge of plant safety-related systems to understand the effects of fire and fire suppressants on safe shutdown capability.	6.2.1.3	Conform	See Subsection 9.5.1.6.
CP COL 9.5(1)	The fire brigade shall be notified immediately upon verification of a fire or fire suppression system actuation.	6.2.1.4	Conform	See Subsection 9.5.1.6.
CP COL 9.5(1)	Plant fire brigade members shall be physically qualified to perform the duties assigned.	6.2.2.1	Conform	See Subsection 9.5.1.6.
CP COL 9.5(1)	Each member shall pass an annual physical examination to determine that the fire brigade member can perform strenuous activity.	6.2.2.2	Conform	See Subsection 9.5.1.6.
CP COL 9.5(1)	The physical examination shall determine each member's ability to use respiratory protection equipment.	6.2.2.3	Conform	See Subsection 9.5.1.6.
CP COL 9.5(1)	Each fire brigade member shall meet training qualifications as specified in Chapter 6, Section 6.3.	6.2.2.4	Conform	See Subsection 9.5.1.6.
CP COL 9.5(1)	Plant fire brigade members shall receive training consistent with the requirements contained in NFPA 600, Standard on Industrial Fire Brigades, or NFPA 1500, Standard on Fire Department Occupational Safety and Health Program, as appropriate.	6.3.1.1	Conform	
CP COL 9.5(1)	Fire brigade members shall be given quarterly training and practice in fire fighting.	6.3.1.2	Conform	See Subsection 9.5.1.6.
CP COL 9.5(1)	A written program shall detail the fire brigade training program.	6.3.1.3	Conform	See Subsection 9.5.1.6.
CP COL 9.5(1)	Written records that include but are not limited to the following shall be maintained for each fire brigade member: (1) Initial fire brigade classroom and hands-on training. (2) Refresher training. (3) Special training schools attended. (4) Drill attendance records. (5) Leadership training for fire brigades.	6.3.1.4	Conform	
CP COL 9.5(1)	Drills shall be conducted quarterly for each shift to test the response capability of the fire brigade.	6.3.2.1	Conform	See Subsection 9.5.1.6.

**Comanche Peak Nuclear Power Plant, Units 3 & 4
COL Application
Part 2, FSAR**

**Table 9.5.1-2R (Sheet 14 of 70)
CPNPP Units 3 & 4 Fire Protection Program Conformance with NFPA 804**

Standard Requirement	Paragraph	Conformance	Remarks	
CP COL 9.5(1)	Fire brigade drills shall be developed to test and challenge fire brigade response, including the following: (1) Brigade performance as a team. (2) Proper use of equipment. (3) Effective use of prefire plans. (4) Coordination with other groups.	6.3.2.2	Conform	See Subsection 9.5.1.6.
CP COL 9.5(1)	Fire brigade drills shall be conducted in various plant areas, especially in those areas identified by the fire hazards analysis to be critical to plant operation and to contain significant fire hazards.	6.3.2.3	Conform	
CP COL 9.5(1)	Drill records shall be maintained detailing the drill scenario, fire brigade member response, and ability of the fire brigade to perform the assigned duties.	6.3.2.4	Conform	
CP COL 9.5(1)	A critique shall be held after each drill.	6.3.2.5	Conform	See Subsection 9.5.1.6.
CP COL 9.5(1)	The plant fire brigade shall be provided with equipment that enables its members to adequately perform their assigned tasks.	6.4.1	Conform	See Subsection 9.5.1.6.
CP COL 9.5(1)	Fire brigade equipment shall be tested and maintained.	6.4.2	Conform	See Subsection 9.5.1.6.
CP COL 9.5(1)	Written records shall be retained for review.	6.4.3	Conform	
CP COL 9.5(1)	A mutual aid agreement shall be offered to the local off-site fire department.	6.5.1.1	Conform	See Subsection 9.5.1.6.
CP COL 9.5(1)	Where possible, the plant fire protection manager and the off-site fire authorities shall develop a plan for their interface.	6.5.1.2	Conform	See Subsection 9.5.1.6.
CP COL 9.5(1)	The fire protection manager also shall consult with the off-site fire department to make plans for fire fighting and rescue, including assistance from other organizations, and to maintain these plans.	6.5.1.3	Conform	
CP COL 9.5(1)	The local off-site fire department shall be invited to participate in an annual drill.	6.5.1.4	Conform	See Subsection 9.5.1.6.

**Comanche Peak Nuclear Power Plant, Units 3 & 4
COL Application
Part 2, FSAR**

**Table 9.5.1-2R (Sheet 15 of 70)
CPNPP Units 3 & 4 Fire Protection Program Conformance with NFPA 804**

Standard Requirement	Paragraph	Conformance	Remarks	
CP COL 9.5(1)	Fire fighters from the off-site fire department who are expected to respond to a fire at the plant shall be familiar with the plant layout.	6.5.2.1	Conform	See Subsection 9.5.1.6.
CP COL 9.5(1)	The access routes to fires in the controlled area (to which access doors are locked) shall be planned in advance.	6.5.2.2	Conform	
CP COL 9.5(1)	The off-site fire department shall be offered instruction and training in radioactive materials, radiation, and hazardous materials that could be present.	6.5.2.3	Conform	
CP COL 9.5(1)	Plant management shall designate a plant position to act as a liaison to the off-site fire department when it responds to a fire or other emergency at the plant.	6.5.3.1	Conform	
CP COL 9.5(1)	Plant management shall ensure that the off-site fire department personnel are escorted at all times and emergency actions are not delayed.	6.5.3.2	Conform	
CP COL 9.5(1)	The fire brigade shall have at its disposal the necessary equipment to assist with routing water from the affected area.	6.6	Conform	
CP COL 9.5(1)	All plant areas shall be accessible for fire-fighting purposes.	6.7.1	Conform	
CP COL 9.5(1)	Prefire plans shall identify those areas of the plant that are locked and have limited access for either security or radiological control reasons.	6.7.2	Conform	
CP COL 9.5(1)	Provisions shall be made to allow access to the locked areas, including having security and health physics personnel respond to the fire area along with the fire brigade, if necessary.	6.7.2.1	Conform	
CP COL 9.5(1)	Health physics personnel shall confer with the fire brigade leader to determine the safest method of access to any radiologically controlled area.	6.7.2.2	Conform	
CP COL 9.5(1)	Full advantage shall be taken of all fixed radiation shielding to protect personnel responding for fire suppression purposes.	6.8.1	Conform	

**Comanche Peak Nuclear Power Plant, Units 3 & 4
COL Application
Part 2, FSAR**

**Table 9.5.1-2R (Sheet 16 of 70)
CPNPP Units 3 & 4 Fire Protection Program Conformance with NFPA 804**

Standard Requirement	Paragraph	Conformance	Remarks	
CP COL 9.5(1)	Health physics personnel shall advise the fire brigade leader of the best method for affording radiological protection.	6.8.2	Conform	
CP COL 9.5(1)	If fixed ventilation systems are not capable of removing smoke and heat, the fire brigade shall utilize portable ventilation equipment (See Chapter 8, Section 8.4).	6.9	Conform	See Subsection 9.5.1.6. CPNPP Fire Brigade has portable equipment.
	A fire-safe shutdown analysis shall be prepared and maintained for the operating life of the reactor, and shall include, as a minimum, all of the following: (1) Fire hazards analysis. (2) Safe shutdown analysis. (3) Internal plant examination of external fire events for severe accident vulnerabilities.	7.2	Conform	US-APWR designed to allow safe-shutdown from two of three unaffected trains of safety-related equipment using normal plant equipment. See DCD Chapter 7, Section 7.4.
	The fire hazards analysis shall include the criteria indicated in Chapter 4, Section 4.4.	7.2.1	Conform	See Appendix 9A.
	A safe shutdown analysis of the effects of a fire on those essential structures, systems, and components required to safely shut down the plant and maintain it in a safe shutdown condition shall be performed, including, as a minimum, the requirements of this section.	7.2.2	Conform	
	A safe shutdown system available/unavailable calculation or table that provides the following shall be prepared and maintained for each fire area: (1) The document shall identify all safe shutdown equipment that is operable or inoperable due to the effects of a fire in that fire area. (2) The document shall demonstrate compliance with the requirements of Chapter 7, Sections 7.3 and 7.4.	7.2.2.1	Conform	See Appendix 9A.
	A shutdown logic diagram shall be available that identifies the conditions necessary to achieve and maintain safe shutdown capability in the event of a fire and	7.2.2.2	Conform	
	those plant features necessary to realize these conditions, including auxiliary and support features.			

**Comanche Peak Nuclear Power Plant, Units 3 & 4
COL Application
Part 2, FSAR**

**Table 9.5.1-2R (Sheet 17 of 70)
CPNPP Units 3 & 4 Fire Protection Program Conformance with NFPA 804**

Standard Requirement	Paragraph	Conformance	Remarks
A risk assessment that estimates the potential risk from a fire in relation to the plant's core damage frequency shall be prepared.	7.2.3	Conform	Fire PRA for US-APWR is performed. See Chapter 19.
An industry-accepted examination process shall be used for the risk assessment.	7.2.3.1	Conform	Fire PRA for US-APWR follows NUREG/CR 6850 guidance.
An acceptable risk assessment shall demonstrate that the probability of core damage as a result of an internal fire is less than 1×10^{-6} per reactor year.	7.2.3.2	See Chapter 19.	
The internal plant examination of external fire events for severe accident vulnerabilities shall be used to evaluate the level of safety of the plant and shall not be used to reduce the overall plant fire protection design basis.	7.2.3.3	Conform	
Only one fire shall be assumed to occur at a given time, and for the purpose of a safe shutdown analysis, damage shall be assumed to occur immediately.	7.3.1.1	Conform	
All components, including electrical cables, that are susceptible to fire damage in a single fire area (except primary containment and annulus areas) shall be assumed to be disabled or to be spuriously actuated, whichever is the worst case.	7.3.1.2	Conform	
A fire shall not impair safe shutdown capability inside primary containment or annulus areas.	7.3.1.3	Conform	
The plant shall be assumed to be operating at 100% power, with all components in their normal configuration, when a postulated fire occurs; however, the analysis also shall consider changes in plant configurations during all normal modes of operation.	7.3.1.4	Conform	
A concurrent single active component failure independent of the postulated fire shall not be assumed to occur.	7.3.1.5	Conform	

**Comanche Peak Nuclear Power Plant, Units 3 & 4
COL Application
Part 2, FSAR**

**Table 9.5.1-2R (Sheet 18 of 70)
CPNPP Units 3 & 4 Fire Protection Program Conformance with NFPA 804**

Standard Requirement	Paragraph	Conformance	Remarks
Plant accidents or severe natural phenomena shall not be assumed to occur concurrently with a postulated fire, except as specified in 7.3.2.	7.3.1.6	Conform	
A loss of off-site power shall be assumed concurrent with the postulated fire only where the safe shutdown analysis (including alternative shutdown) indicates the fire could initiate the loss of off-site power.	7.3.1.7	Conform	
Fire-safe shutdown components shall be capable of performing all the following functions in the event of the postulated fire: (1) Achieving and maintaining subcritical reactivity conditions in the reactor. (2) Maintaining the reactor coolant inventory such that plant safety limits are not violated. (3)* Establishing reactor decay heat removal to prevent fuel damage and to achieve and maintain cold shutdown conditions. (4) Providing support functions such as process cooling and lubrication necessary to allow operation of the FSSD components. (5) Providing direct readings of the process variables necessary to perform and control the FSSD functions.	7.3.1.8	Conform	
During a postfire shutdown, the fission product boundary integrity shall be maintained within acceptable limits (e.g., fuel clad damage, rupture of any primary coolant boundary, or rupture of the primary containment boundary).	7.3.1.9	Conform	
An evaluation of spurious signals shall be performed based on the following:	7.3.1.10.1	Conform	

**Comanche Peak Nuclear Power Plant, Units 3 & 4
COL Application
Part 2, FSAR**

**Table 9.5.1-2R (Sheet 19 of 70)
CPNPP Units 3 & 4 Fire Protection Program Conformance with NFPA 804**

Standard Requirement	Paragraph	Conformance	Remarks
(1) All components shall be assumed to be in their normal operating positions for the particular mode of operation being considered by the spurious signal evaluation. (2) The evaluation shall consider the following cable failure modes: (a) A hot short in which individual conductors within a cable are shorted to individual conductors of a different cable such that a de-energized circuit might become energized by shorting to an external source of electrical power. (b) An open circuit in which the cable failure results in the loss of electrical continuity. (c) A short to ground in which a cable conductor shorts to grounded structures. (d) A short circuit in which individual conductors within multiconductor cable short to each other.			
Functional failure or damage modes of equipment and components that can spuriously operate shall be considered.	7.3.1.10.2	Conform	
The postulates specified in 7.3.1.11.1 through 7.3.1.11.5 shall be used in the analysis of fire-induced spurious actuation of equipment.	7.3.1.11	Conform	
FSSD capability shall not be adversely affected by simultaneous spurious actuation of all valves in a single high-to-low pressure interface line where the power or control circuits for the valves can be damaged by a postulated fire.	7.3.1.11.1	Conform	
For other than high-to-low pressure boundaries, FSSD capability shall not be adversely affected by spurious actuation or signal.	7.3.1.11.2	Conform	
Separate conditions shall be analyzed concurrent with the spurious actuation(s) or signal addressed in 7.3.1.11.1 and 7.3.1.11.2.	7.3.1.11.3	Conform	
All automatic functions (signal, logic, etc.) from the circuits that can be damaged by the postulated fire shall be assumed lost or assumed to function as intended, whichever is the worst case.	7.3.1.11.4	Conform	

**Comanche Peak Nuclear Power Plant, Units 3 & 4
COL Application
Part 2, FSAR**

**Table 9.5.1-2R (Sheet 20 of 70)
CPNPP Units 3 & 4 Fire Protection Program Conformance with NFPA 804**

Standard Requirement	Paragraph	Conformance	Remarks
All potential spurious signals shall be analyzed, but only one spurious signal shall be postulated to occur at a time for purposes of analysis, except for high-to-low pressure interface valves.	7.3.1.11.5	Conform	
For the purpose of analysis for cases involving high-to-low pressure interface, hot shorts involving three-phase ac circuits shall be postulated.	7.3.1.12	Conform	
For ungrounded dc circuits, if it can be shown that only two hot shorts of the proper polarity without grounding could cause spurious operation, no further evaluation shall be necessary, except for cases involving high-to-low pressure interfaces.	7.3.1.13	Conform	
All common power supply associated circuits of concern shall be isolated from FSSD circuits by coordinated circuit breakers or fuses.	7.3.1.14	Conform	
Protection for circuits associated by common enclosure shall meet the following criteria: (1) Protection shall be demonstrated by ensuring that suitable electrical overcurrent protection devices are provided for all cables. (2) Appropriate measures to prevent the propagation of fire, such as rated fire stops and seals in the raceway or enclosure, shall be provided.	7.3.1.15.1	Conform	
The overcurrent protection devices specified in 7.3.1.15.1(1) shall be located outside the fire area containing the common enclosure.	7.3.1.15.2	Conform	
A high-impedance fault shall be assumed to occur as a result of a fire.	7.3.1.16.1	Conform	
Evaluation of the impact of high-impedance faults on the ability to achieve and maintain safe shutdown shall be performed to demonstrate that sufficient capacity exists in the electrical protective system to preclude a trip of the main source breaker to the supply.	7.3.1.16.2	Conform	

**Comanche Peak Nuclear Power Plant, Units 3 & 4
COL Application
Part 2, FSAR**

**Table 9.5.1-2R (Sheet 21 of 70)
CPNPP Units 3 & 4 Fire Protection Program Conformance with NFPA 804**

Standard Requirement	Paragraph	Conformance	Remarks
A risk assessment that demonstrates the potential risk from a seismically induced fire in relationship to the plant's core damage frequency shall be prepared and used as follows: (1) The assessment shall be used to evaluate the level of safety of the plant. (2) The assessment shall not be used to reduce the overall plant fire protection design basis.	7.3.2.1	Conform	
An industry-accepted examination process shall be used for the risk assessment.	7.3.2.2	Conform	
One safety division of systems that is necessary to achieve and maintain safe shutdown from either the control room or emergency control station(s) shall be maintained free of fire damage by a single fire, including an exposure fire.	7.4.1	Conform	
One safety division of systems that is necessary to prevent the initiation of a design basis accident shall be maintained free of fire damage from a single fire that occurs outside the MCR.	7.4.2	Conform	
Redundant cables, equipment, components, and associated circuits of nuclear safety-related or safe shutdown systems shall be located in separate fire areas, unless otherwise permitted by 7.4.3.1.	7.4.3	Conform	
Where redundant system separation inside containment cannot be achieved, other measures shall be permitted in accordance with Chapter 7, Section 7.6 to prevent a fire from causing the loss of function of nuclear safety-related or safe shutdown systems.	7.4.3.1	Conform	

**Comanche Peak Nuclear Power Plant, Units 3 & 4
COL Application
Part 2, FSAR**

**Table 9.5.1-2R (Sheet 22 of 70)
CPNPP Units 3 & 4 Fire Protection Program Conformance with NFPA 804**

Standard Requirement	Paragraph	Conformance	Remarks
The fire barrier forming the separate fire areas specified in 7.4.3 shall have a 3-hour fire rating and automatic area-wide detection shall be installed throughout the fire areas, unless all the following criteria are met: (1) The fire barriers forming the fire areas shall have a minimum fire-resistive rating of 1 hour. (2) Automatic area-wide detection and suppression shall be installed throughout the fire areas. (3) Structural steel forming a part of or supporting the fire barriers shall be protected to provide fire resistance equivalent to that of the barrier.	7.4.3.2	Conform	
Structural steel forming a part of or supporting the fire barriers shall be protected to provide fire resistance equivalent to that of the 3-hour fire-rated barrier specified in 7.4.3.2.	7.4.3.3	Conform	
Fire areas separated by minimum 3-hour fire-rated barriers shall be established to separate redundant safety divisions and safe shutdown functions from fire hazards in nonsafety or safe shutdown-related areas of the plant.	7.4.4	Conform	
In fire areas containing components of either a nuclear safety-related or safe shutdown system, special attention shall be given to detecting and suppressing fire that can adversely affect the system.	7.4.5	Conform	
Measures that shall be taken to reduce the effects of a postulated fire in a given fire area include the following: (1) Limiting the amount of combustible materials (see Chapter 5, Section 5.3) (2) Providing fire-rated barriers between major components and equipment to limit fire spread within a fire area (see Chapter 8, Section 8.1) (3) Installing fire detection (see Chapter 9, Section 9.8) and fixed suppression systems (see Chapter 9, Section 9.6)	7.4.6	Conform	
CP COL 9.5(1) Procedures shall be developed for actions necessary to achieve FSSD.	7.5.1	Conform	See Subsection 9.5.1.6.

**Comanche Peak Nuclear Power Plant, Units 3 & 4
COL Application
Part 2, FSAR**

**Table 9.5.1-2R (Sheet 23 of 70)
CPNPP Units 3 & 4 Fire Protection Program Conformance with NFPA 804**

Standard Requirement	Paragraph	Conformance	Remarks	
	Operator actions necessary to achieve FSSD of the reactor shall meet criteria acceptable to the AHJ.	7.5.2.1	Conform	No operator manual actions required to achieve safe-shutdown.
	No credit shall be taken for operator actions required to effect repairs to equipment to achieve FSSD of the reactor.	7.5.2.2	Conform	
CP COL 9.5(1)	Personnel necessary to achieve and maintain the plant in FSSD following a fire shall be provided from the normal on-site staff, exclusive of the fire brigade.	7.5.2.3	Conform	
CP COL 9.5(1)	The operator training program shall include performance-based simulator training on FSSD procedures.	7.5.2.4	Conform	
CP COL 9.5(1)	Walk-through of operator actions necessary to achieve FSSD of the reactor shall be performed to verify that the actions are feasible and shall be integrated into the operator training program.	7.5.2.5	Conform	
CP COL 9.5(1)	Postfire shutdown and recovery plans shall be included in the station emergency preparedness plan.	7.5.2.6	Conform	
CP COL 9.5(1)	Drills and operator requalification training shall ensure that operations personnel are familiar with and can accomplish the necessary actions.	7.5.2.7	Conform	
	Access routes to areas containing equipment necessary for safe shutdown of the reactor shall be protected from the effects of smoke and fire.	7.5.3.1.1	Conform	
	Two separate access routes shall be provided from the MCR to the remote shutdown location.	7.5.3.1.2	Conform	
	Emergency lighting shall be provided for the access routes and the remote shutdown location (see Chapter 8, Section 8.6).	7.5.3.1.3	Comply	
	Operator safety shall not be threatened by fire conditions while FSSD of the reactor is being implemented.	7.5.3.2.1	Conform	
	Operation of equipment required to effect FSSD of the reactor shall not require any extraordinary actions by the operator.	7.5.3.2.2	Conform	

**Comanche Peak Nuclear Power Plant, Units 3 & 4
COL Application
Part 2, FSAR**

**Table 9.5.1-2R (Sheet 24 of 70)
CPNPP Units 3 & 4 Fire Protection Program Conformance with NFPA 804**

Standard Requirement	Paragraph	Conformance	Remarks
Operators (e.g., handwheels of valves that require manual manipulation for FSSD) shall be readily accessible.	7.5.3.2.3	N/A	No operator manual actions required to achieve fire safe shutdown.
If the handwheel is located more than 5 ft above the floor, it shall be provided with either a chain operator or a permanent platform.	7.5.3.2.3.1	N/A	No manual manipulation of handwheels required to achieve fire safe-shutdown.
The platform shall be of sufficient size to allow the operator to safely perform the manual action.	7.5.3.2.3.2	N/A	No manual manipulation of handwheels required to achieve fire safe-shutdown.
Alternative shutdown capability provided for a specific fire area shall include the following: (1) Achieving and maintaining subcritical reactivity conditions in the reactor (2) Maintaining the reactor coolant inventory (3) Achieving safe shutdown (4) Maintaining safe shutdown following the fire event	7.6.1	N/A	No alternative shutdown required. Shutdown is achieved through normal operation of two out of three undamaged trains of safety-related equipment.
During the postfire shutdown, the reactor coolant system process variables shall be maintained within those values predicted for a loss of normal ac power, and the fission product boundary integrity shall not be affected.	7.6.2	Conform	
Performance goals for reactor shutdown functions shall be the same as those required by 7.3.1.8.	7.6.3	Conform	
The safe shutdown circuits for each fire area shall meet the following criteria: (1) They shall be known to be isolated from associated circuits in the fire area so the hot shorts, shorts to ground, open circuits, or short circuits will not prevent the operation of the safe shutdown equipment. (2) Isolation of associated circuits from the safe shutdown equipment shall be such that a postulated fire involving the associated circuits will not prevent safe shutdown or damage the safe shutdown components.	7.6.4	Conform	

**Comanche Peak Nuclear Power Plant, Units 3 & 4
COL Application
Part 2, FSAR**

**Table 9.5.1-2R (Sheet 25 of 70)
CPNPP Units 3 & 4 Fire Protection Program Conformance with NFPA 804**

	Standard Requirement	Paragraph	Conformance	Remarks
CP COL 9.5(1)	In multiunit plants, each unit shall be separated from adjacent units by either an open space of at least 50 ft or at least a 3-hour-rated fire barrier.	8.1.1.1	Conform	CPNPP Unit 3 is separated from CPNPP Unit 4 by greater than 50 ft. Both units are distant from CPNPP Units 1 and 2.
	Buildings or portions thereof containing nuclear safety-related systems shall be separated from buildings or portions thereof not related to nuclear safety by barriers having a designated fire resistance rating of 3 hours.	8.1.1.2	Conform	
	Buildings containing nuclear safety-related systems shall be permitted to be separated from buildings not related to nuclear safety by an open space of at least 50 ft.	8.1.1.3	Conform	See 8.1.1.2, US-APWR uses 3-hour separation for power block buildings.
	Advanced light water reactor electric generating plants shall be subdivided into separate fire areas to minimize the risk of fire spread	8.1.2.1	Conform	See Appendix 9A for US-APWR fire area descriptions.
	and the resultant consequential damage from fire gases, smoke, heat, radioactive contamination, and fire-fighting activities.			
	In addition to 8.1.2.1, the subdivision into fire areas shall allow adequate access for manual fire suppression activities.	8.1.2.2	Conform	

**Comanche Peak Nuclear Power Plant, Units 3 & 4
COL Application
Part 2, FSAR**

**Table 9.5.1-2R (Sheet 26 of 70)
CPNPP Units 3 & 4 Fire Protection Program Conformance with NFPA 804**

Standard Requirement	Paragraph	Conformance	Remarks
<p>A listed fire barrier having a fire resistance rating of at least 3 hours and with listed 3-hour-rated penetration seals shall be provided as follows:</p> <p>(1) To separate all contiguous buildings or portions thereof serving different purposes, such as reactor containment, auxiliary, turbine, radwaste, control, service, administration, and other occupancy areas as dictated by reactor design.</p> <p>(2) To separate safety-related standby emergency diesel generators and combustion turbines from each other and the rest of the plant.</p> <p>(3) To separate the turbine generator lube oil conditioning system and lube oil storage from the turbine building and adjacent areas.</p> <p>(4) To separate diesel fire pumps and associated equipment from other pumps in the same pump house.</p> <p>(5) To separate all areas with heavy concentrations of cables, such as cable spreading rooms, cable tunnels, cable penetration areas, and cable shafts or chases, including those within the reactor containment, from adjacent areas.</p> <p>(6) To separate auxiliary boiler rooms from adjacent areas.</p> <p>(7) Wherever so determined by the fire hazards analysis.</p>	8.1.2.3	Conform	See Appendix 9A.
<p>To prevent vertical spread of fire, stairways, elevator shafts, trash chutes, and other vertical shafts and plenums shall be enclosed with barriers having a fire resistance rating of at least 2 hours.</p>	8.1.2.4	Conform	
<p>Openings in the barriers specified in 8.1.2.4 shall be protected with listed automatic or self-closing fire doors having a fire protection rating of at least 1½ hours.</p>	8.1.2.5	Conform	
<p>All openings in fire barriers shall be provided with fire door assemblies, fire dampers, penetration seals (fire stops), or other approved means having a fire protection rating consistent with the designated fire resistance rating of the barrier, unless the criterion of 8.1.3.2 is met.</p>	8.1.3.1	Conform	

**Comanche Peak Nuclear Power Plant, Units 3 & 4
COL Application
Part 2, FSAR**

**Table 9.5.1-2R (Sheet 27 of 70)
CPNPP Units 3 & 4 Fire Protection Program Conformance with NFPA 804**

Standard Requirement	Paragraph	Conformance	Remarks
Assemblies used to meet the requirements of 8.1.3.1 that are not listed or approved due to nuclear safety or security requirements shall be demonstrated to be equivalent.	8.1.3.2	Conform	
Fire door assemblies, fire dampers, and fire shutters used in 2-hour-rated fire barriers shall be listed as not less than 1½ hour rated and shall meet the requirements of NFPA 80, Standard for Fire Doors and Fire Windows, for fire door requirements and NFPA 90A, Standard for the Installation of Air-Conditioning and Ventilating Systems, for fire damper requirements, unless otherwise permitted by 8.1.3.4.	8.1.3.3	Conform	
Where approved full-scale fire tests indicate that opening protection is not necessary, the opening protection specified in 8.1.3.3 shall not be required.	8.1.3.4	N/A	No unprotected opening are provided in the fire rated barriers of the US-APWR design.
Windows in fire barriers, such as for a control room or computer room, shall be provided with a listed or approved fire shutter or automatic wall curtain.	8.1.3.4.1	Conform	
Cable openings, piping openings, and building joints shall be provided with fire-rated penetration seals that meet the requirements of ASTM E 814, Fire Tests of Through-Penetration Fire Stops, or UL 1479, Standard for Safety Fire	8.1.3.4.2	Conform	
Tests of Through-Penetration Firestops.			
All conduits shall be sealed at the barrier with a fire-rated seal, if accessible.	8.1.3.4.3	Conform	
As an alternative to 8.1.3.4.3, internally sealing with a fire-rated seal at the first break in the conduit on both sides of the barrier shall be acceptable.	8.1.3.4.3.1	Conform	
For the configuration specified in 8.1.3.4.3.1, the fire rating of the internal conduit seal shall be equivalent to the rating of the fire barrier being penetrated.	8.1.3.4.3.2	Conform	

**Comanche Peak Nuclear Power Plant, Units 3 & 4
COL Application
Part 2, FSAR**

**Table 9.5.1-2R (Sheet 28 of 70)
CPNPP Units 3 & 4 Fire Protection Program Conformance with NFPA 804**

	Standard Requirement	Paragraph	Conformance	Remarks
	Where approved full-scale fire tests indicate that internal conduit seals are not necessary, internal conduit seals shall not be required.	8.1.3.4.3.3	Conform	
	All fire-rated assemblies shall be tested with a positive pressure in the furnace.	8.1.3.4.4	Conform	
CP COL 9.5(1)	Normally closed fire doors in fire barriers shall be identified with a sign indicating "Fire Door — Keep Closed."	8.1.3.4.5	Conform	
	Design features that provide for monitoring and control of fire doors to ensure fire door operability and fire barrier integrity shall be provided, unless otherwise permitted by 8.1.3.6.	8.1.3.5	Conform	
CP COL 9.5(1)	Administrative procedures shall be permitted to be used instead of the design features required by 8.1.3.5.	8.1.3.6	Conform	
	NFPA 101, Life Safety Code, shall be the standard for life safety from fire in the design and operation of the Advanced Light Water Reactor, except where modified by this standard.	8.2.1	Conform	
	The majority of the areas involved in the transfer of nuclear energy to electrical energy shall be considered as special-purpose industrial occupancies and special-	8.2.2	Conform	
	structure windowless buildings, as defined in NFPA 101, Life Safety Code.			
	In determining the exits for an Advanced Light Water Reactor plant, the actual number of personnel and occupancy hazards during maintenance, refueling, and testing shall determine the exit requirements and occupant load based on NFPA 101, Life Safety Code.	8.2.3	Conform	
CP COL 9.5(2)	Cafeterias, lunchrooms, conference rooms, and assembly rooms having an occupant load greater than 50 shall conform to the new assembly occupancy requirements in NFPA 101, Life Safety Code.	8.2.4	Conform	

**Comanche Peak Nuclear Power Plant, Units 3 & 4
COL Application
Part 2, FSAR**

**Table 9.5.1-2R (Sheet 29 of 70)
CPNPP Units 3 & 4 Fire Protection Program Conformance with NFPA 804**

Standard Requirement	Paragraph	Conformance	Remarks
CP COL 9.5(2)	General office areas, office buildings, and training facilities shall conform to the business occupancy requirements in NFPA 101, Life Safety Code.	8.2.5	Conform
CP COL 9.5(2)	Warehouses and storage areas shall conform to the storage occupancy requirements in NFPA 101, Life Safety Code.	8.2.6	Conform
	Construction materials for the Advanced Light Water Reactor plant shall be classified by at least one of the following test methods appropriate to the end-use configuration of the material: (1) NFPA 220, Standard on Types of Building Construction. (2) ASTM E 136, Standard Test Method for Behavior of Materials in a Vertical Tube Furnace at 750°C. (3) NFPA 251, Standard Methods of Tests of Fire Resistance of Building Construction and Materials(ASTM E 119, Standard Test Methods for Fire Tests of Building Construction and Materials). (4) NFPA 253, Standard Method of Test for Critical Radiant Flux of Floor Covering Systems Using a Radiant Heat Energy Source.	8.3.1	Conform
	(5) NFPA 255, Standard Method of Test of Surface Burning Characteristics of Building Materials(ASTM E 84, Standard Test Method for Surface Burning Characteristics of Building Materials). (6) NFPA 256, Standard Methods of Fire Tests of Roof Coverings. (7) NFPA 259, Standard Test Method for Potential Heat of Building Materials		
	All walls, floors, and structural components, except interior finish materials, shall be of noncombustible construction.	8.3.2	Conform
	Interior wall or ceiling finish classification shall be in accordance with NFPA 101, Life Safety Code, requirements for Class A material.	8.3.2.1	Conform
	Interior floor finish classification shall be in accordance with NFPA 101, Life Safety Code, requirements for Class I interior floor finish.	8.3.2.2	Conform

**Comanche Peak Nuclear Power Plant, Units 3 & 4
COL Application
Part 2, FSAR**

**Table 9.5.1-2R (Sheet 30 of 70)
CPNPP Units 3 & 4 Fire Protection Program Conformance with NFPA 804**

Standard Requirement	Paragraph	Conformance	Remarks
Thermal insulation materials, radiation shielding materials, ventilation duct materials, soundproofing materials, and suspended ceilings, including light diffusers and their supports, shall be noncombustible or limited combustible.	8.3.3	Conform	
Wiring above suspended ceilings shall be listed for plenum use, routed in armored cable, routed in metallic conduits, or routed in cable trays with solid metal top and bottom covers.	8.3.4	Conform	
Roof coverings shall be Class A as determined by tests described in NFPA 256, Standard Methods of Fire Tests of Roof Coverings.	8.3.5	Conform	
Metal roof deck construction shall be Class I as listed by Factory Mutual or fire acceptable as listed by Underwriters Laboratories Inc.	8.3.6	Conform	
Bulk flammable gas storage, either compressed or cryogenic, shall not be permitted inside structures housing safety-related systems.	8.3.7	Conform	
Storage of flammable gas, such as hydrogen, shall be located outdoors or in separate detached buildings, so that a fire or explosion will not adversely affect any safety-related systems or equipment.	8.3.7.1	Conform	
Outdoor high-pressure flammable gas storage containers shall be located so that the long axis is not pointing at the building walls.	8.3.7.2	Conform	
The following requirements shall apply to bulk storage of flammable and combustible liquids: (1) Storage shall not be permitted inside structures housing safety-related systems. (2) As a minimum, the storage and use shall comply with the requirements of NFPA 30, Flammable and Combustible Liquids Code.	8.3.8	Conform	

**Comanche Peak Nuclear Power Plant, Units 3 & 4
COL Application
Part 2, FSAR**

**Table 9.5.1-2R (Sheet 31 of 70)
CPNPP Units 3 & 4 Fire Protection Program Conformance with NFPA 804**

Standard Requirement	Paragraph	Conformance	Remarks
The design, installation, and operation of ventilation systems necessary for normal and emergency operation of the plant shall be in accordance with NFPA 90A, Standard for the Installation of Air-Conditioning and Ventilating Systems.	8.4.1	Conform	
Automatic damper closure or shutdown of ventilation systems shall be consistent with nuclear safety and the safety of onsite personnel.	8.4.2	Conform	
Smoke removal shall be provided for nuclear safety-related areas of the plant, and the following criteria also shall apply: (1) Equipment shall be suitable for removing smoke without damage to equipment. (2) The release to the environment of smoke containing radioactive materials shall be monitored in accordance with emergency plans.	8.4.3	Conform	
(3) For those plants provided with complete automatic sprinkler protection, fixed ventilation systems for the removal of smoke shall not be required.			
Smoke and heat removal systems shall be provided for other fire areas based on the fire hazards analysis, unless otherwise permitted by 8.4.3.2.	8.4.3.1	Conform	
For those plants provided with complete automatic sprinkler protection, fixed ventilation systems for the removal of smoke shall not be required.	8.4.3.2	Conform	
Smoke from nonnuclear areas shall be discharged directly outside to an area that will not adversely affect nuclear safety-related areas.	8.4.3.3	Conform	
Any ventilation system designed to exhaust potentially radioactive smoke or heat shall be evaluated to ensure that inadvertent operation or single failures will not violate the radiologically controlled areas of the plant.	8.4.3.4	Conform	

**Comanche Peak Nuclear Power Plant, Units 3 & 4
COL Application
Part 2, FSAR**

**Table 9.5.1-2R (Sheet 32 of 70)
CPNPP Units 3 & 4 Fire Protection Program Conformance with NFPA 804**

Standard Requirement	Paragraph	Conformance	Remarks
To facilitate manual fire fighting, smoke control shall be provided in high-density cable-use areas, switchgear rooms, diesel fuel oil storage areas, T/Bs, and other areas where potential exists for heavy smoke and heat conditions as determined by the fire hazards analysis.	8.4.4	Conform	
The power supply and controls for mechanical ventilation systems used for smoke removal shall be routed outside the fire area served by the system or protected from fire damage.	8.4.5	Conform	
The fresh air supply intakes to plant areas shall be located remote from the exhaust air outlets and smoke vents of other fire areas.	8.4.6	Conform	
Where natural-convection ventilation is used, a minimum ratio of vent area to floor area shall be at	8.4.7	Conform	
least 1 to 200, except in oil hazard areas, where at least a 1-to-100 ratio shall be provided.			
Combustible ducts, including fire-retardant types, shall not be used for ventilation systems.	8.4.8.1	Conform	
Fire dampers shall be installed in accordance with NFPA 90A, Standard for the Installation of Air-Conditioning and Ventilating Systems. Consideration shall be given to the velocity in the duct.	8.4.8.2	Conform	
Where full-scale fire tests that are conducted by testing laboratories indicate that fire dampers are not necessary to prevent fire spread through a fire-rated barrier, fire dampers shall be permitted to be omitted from the fire barrier.	8.4.8.2.1	Conform	
As an alternative to fire dampers, the duct system shall be permitted to be enclosed or constructed to provide the required fire barrier through adjacent areas (Refer to Figure A.8.4.8.2).	8.4.8.2.2	Conform	
Listed fire dampers having a rating of 1½ hours shall be installed where ventilation ducts penetrate fire barriers having a required fire resistance rating of 2 hours.	8.4.8.3	Conform	

**Comanche Peak Nuclear Power Plant, Units 3 & 4
COL Application
Part 2, FSAR**

**Table 9.5.1-2R (Sheet 33 of 70)
CPNPP Units 3 & 4 Fire Protection Program Conformance with NFPA 804**

Standard Requirement	Paragraph	Conformance	Remarks
Approved fire dampers having a fire protection rating of 3 hours shall be installed where ventilation ducts penetrate required 3-hour fire barriers.	8.4.8.4	Conform	
Fire dampers shall be equipped for automatic closure by thermal release elements, and one of the following criteria shall be met: (1) The fire damper shall be mounted directly into the separating wall. (2) The duct shall be protected between the wall and the damper according to the fire resistance of the separating wall structure.	8.4.8.5	Conform	
Fire dampers shall be designed and installed so that the air velocity in the ducts assists in closing fire dampers and does not preclude proper damper closure.	8.4.8.6	Conform	
Ventilation ducts containing fire dampers shall be provided with access ports for ease of inspection and for replacement of the thermal element.	8.4.8.7	Conform	
Air entry filters shall have approved noncombustible filter media that produce a minimum amount of smoke (UL Class 1) when subjected to heat.	8.4.9.1	Conform	
To decrease the fire hazard of air entry and oil-bath-type filters, only approved fire-resistive adhesives and oils meeting all of the following criteria shall be used: (1) They shall be in accordance with ASTM D 92, Standard Test Method for Flash and Fire Points by Cleveland Open Cup. (2) Their flash points shall be equal to or greater than 464°F (240°C). (3) They shall not produce appreciable smoke.	8.4.9.2	Conform	
High-efficiency particulate air (HEPA) filters shall meet the requirements of UL 586, Standard for Test Performance of High-Efficiency Particulate Air Filter Units.	8.4.9.3	Conform	

**Comanche Peak Nuclear Power Plant, Units 3 & 4
COL Application
Part 2, FSAR**

**Table 9.5.1-2R (Sheet 34 of 70)
CPNPP Units 3 & 4 Fire Protection Program Conformance with NFPA 804**

Standard Requirement	Paragraph	Conformance	Remarks
Fixed water spray systems shall be provided for charcoal adsorber beds containing more than 100 lb (45.4 kg) of charcoal.	8.4.9.4	Conform	
Fire suppression systems shall be installed to protect filters that collect combustible material.	9.4.9.5	Conform	
Drainage shall be provided in all areas of the plant for the removal of all liquids directly to safe areas or for containment in the area without adverse flooding of equipment and without endangering other areas.	8.5.1	Conform	
Drainage and the prevention of equipment water damage shall be accomplished by one or more of the following: (1) Floor drains. (2) Floor trenches. (3) Open doorways or other wall openings. (4) Curbs for containing or directing drainage. (5) Equipment pedestals. (6) Pits, sumps, and sump pumps	8.5.2	Conform	
Drainage and any associated drainage facilities for a given area shall be sized to accommodate the volume of liquid produced by all of the following: (1) The spill of the largest single container of any flammable or combustible liquids in the area. (2) Where automatic suppression is provided throughout, the credible volume of discharge (as determined by the fire hazards analysis) for the suppression system operating for a period of 30 minutes. (3)* Where automatic suppression is not provided throughout, the contents of piping systems and containers that are subject to failure in a fire. (4) Where the installation is outside, the volume of credible environmental factors such as rain and snow. (5) Where automatic suppression is not provided throughout, the volume based on a manual fire-fighting flow rate of 500 gal/min (1892.5 L/min) for a duration of 30 minutes, unless the fire hazards analysis demonstrates a different flow rate and duration.	8.5.3	Conform	

**Comanche Peak Nuclear Power Plant, Units 3 & 4
COL Application
Part 2, FSAR**

**Table 9.5.1-2R (Sheet 35 of 70)
CPNPP Units 3 & 4 Fire Protection Program Conformance with NFPA 804**

Standard Requirement	Paragraph	Conformance	Remarks
Floor drainage from areas containing flammable or combustible liquids shall be trapped to prevent the spread of burning liquids beyond the fire area.	8.5.4	Conform	
Where gaseous fire suppression systems are installed, floor drains shall be provided with adequate seals, or the fire suppression system shall be sized to compensate for the loss of fire suppression agent through the drains.	8.5.5	Conform	
CP COL 9.5(1) Drainage facilities shall be provided for outdoor oil-insulated transformers, or the ground shall be sloped such that oil spills flow away from buildings, structures, and adjacent transformers.	8.5.6	Conform	
CP COL 9.5(1) Unless drainage from oil spills is accommodated by sloping the ground around transformers away from structures or adjacent equipment, consideration shall be given to providing curbed areas or pits around transformers.	8.5.6.1	Conform	
CP COL 9.5(1) If a layer of uniformly graded stone is provided in the bottom of the curbed area or pit as a means of minimizing ground fires, the following shall be assessed: (1) The sizing of the pit shall allow for the volume of the stone. (2) The design shall address the possible accumulation of sediment or fines in the stone.	8.5.6.2	Conform	See Subsection 9.5.1.2.1.
CP COL 9.5(1) For facilities consisting of more than one generating unit, a curb or trench drain shall be provided on solid floors where the potential exists for an oil spill, such that oil released from the incident on one unit will not expose an adjacent unit.	8.5.7	Conform	
Water drainage from areas that might contain radioactivity shall be collected, sampled, and analyzed before discharge to the environment.	8.5.8	Conform	
Water released during fire suppression operations in areas containing radioactivity shall be drained to a location that is acceptable for the containment of radioactive materials.	8.5.9	Conform	

**Comanche Peak Nuclear Power Plant, Units 3 & 4
COL Application
Part 2, FSAR**

**Table 9.5.1-2R (Sheet 36 of 70)
CPNPP Units 3 & 4 Fire Protection Program Conformance with NFPA 804**

Standard Requirement	Paragraph	Conformance	Remarks
Emergency lighting units shall provide lighting levels as required in 8.6.2.	8.6.1	Conform	See Subsection 9.5.3.3.2.
The lighting units shall be sized to provide a duration of operation that will illuminate the egress and access routes to areas containing safe shutdown equipment and the equipment operation until all required operator actions are completed or until normal or emergency plant lighting can be reestablished.	8.6.2	Conform	See Subsection 9.5.3.3.2.
The illumination of means of egress shall be in accordance with NFPA 101, Life Safety Code, and shall include emergency lighting and marking of the means of egress.	8.6.3	Conform	
The floor of the means of egress and the safe shutdown operations shall be illuminated to values of not less than 1 footcandle measured at the floor and at safe shutdown equipment at all points, including the following: (1) Angles. (2) Intersections of corridors. (3) Passageways. (4) Stairways. (5) Landings of stairways. (6) Exit doors. (7) Safe shutdown equipment. (8) Access and egress routes to safe shutdown equipment.	8.6.4	Conform	
The required illumination shall be so arranged that the failure of any single lighting unit, such as the burning out of a single light bulb, will not leave any area in darkness.	8.6.5	Conform	
CP COL 9.5(1) Suitable battery-powered hand lights shall be provided for emergency use by the fire brigade and other operations personnel required to achieve safe plant shutdown.	8.6.6	Conform	
The plant shall be provided with a lightning protection system in accordance with NFPA 780, Standard for the Installation of Lightning Protection Systems.	8.7	Conform	

**Comanche Peak Nuclear Power Plant, Units 3 & 4
COL Application
Part 2, FSAR**

**Table 9.5.1-2R (Sheet 37 of 70)
CPNPP Units 3 & 4 Fire Protection Program Conformance with NFPA 804**

Standard Requirement	Paragraph	Conformance	Remarks
As a minimum, combustible cable insulation and jacketing material shall meet the fire and flame test requirements of IEEE 383, Standard for Type Test of Class IE Electric Cables, Field Splices and Connections for Nuclear Power Generating Stations.	8.8.1	Conform	
Meeting the requirements of IEEE 383, Standard for Type Test of Class IE Electric Cables, Field Splices and Connections for Nuclear Power Generating Stations, shall not eliminate the need for protection as specified in this standard and the fire hazards analysis.	8.8.2	Conform	
Fiber optic cable insulation and jacketing material shall meet the fire and flame test requirements of IEEE 383, Standard for Type Test of Class IE Electric Cables, Field Splices and Connections for Nuclear Power Generating Stations.	8.8.3	Conform	
Group cabling shall be routed away from exposure hazards or protected as specified in this standard.	8.8.4	Conform	
Group cabling shall not be routed near sources of ignition.	8.8.4.1	Conform	
Group cabling shall not be routed near flammable and combustible liquid hazards.	8.8.4.2	Conform	
Cable raceways shall be used only for cables.	8.8.5	Conform	
Only metal shall be used for cable trays.	8.8.6	Conform	
Only metallic tubing shall be used for conduit, unless otherwise permitted by 8.8.7.1.	8.8.7	Conform	
Nonmetallic conduit shall be permitted to be used with concrete encasement or for direct burial runs.	8.8.7.1	Conform	
Thin-wall metallic tubing shall not be used.	8.8.7.2	Conform	

**Comanche Peak Nuclear Power Plant, Units 3 & 4
COL Application
Part 2, FSAR**

**Table 9.5.1-2R (Sheet 38 of 70)
CPNPP Units 3 & 4 Fire Protection Program Conformance with NFPA 804**

Standard Requirement	Paragraph	Conformance	Remarks
Flexible metallic tubing shall be used only in lengths less than 5 ft. to connect components to equipment.	8.8.7.3	Conform	
Other raceways shall be made of noncombustible materials.	8.8.7.4	Conform	
Buildings shall be protected from exposure fires by any one of the following: (1) Listed 3-hour fire barrier with automatic or self-closing fire doors having a fire protection rating of 3 hours and listed penetration protection of a 3-hour rating. (2) Spatial separation of at least 50 ft. (3) Exterior exposure protection.	8.9	Conform	
The electrical design and installation of electrical generating, control, transmission, distribution, and metering of electrical energy shall be provided in accordance with NFPA 70, National Electrical Code, or ANSI/IEEE C2, National Electrical Safety Code, as applicable.	8.10	Conform	
CP COL 9.5(1) The plant-approved voice/alarm communications system in accordance with NFPA 72, National Fire Alarm Code, shall be available on a priority basis for fire announcements, directing the plant fire brigade, and fire evacuation announcements.	8.11.1	Conform	
CP COL 9.5(1) A portable radio communications system shall be provided for use by the fire brigade and other operations personnel required to achieve safe shutdown.	8.11.2	Conform	
CP COL 9.5(1) The radio communications system shall not interfere with the communications capabilities of the plant security force.	8.11.3	Conform	
CP COL 9.5(1) The impact of fire damage on the communications systems shall be considered when fixed repeaters are installed to permit the use of portable radios.	8.11.4	Conform	

**Comanche Peak Nuclear Power Plant, Units 3 & 4
COL Application
Part 2, FSAR**

**Table 9.5.1-2R (Sheet 39 of 70)
CPNPP Units 3 & 4 Fire Protection Program Conformance with NFPA 804**

Standard Requirement	Paragraph	Conformance	Remarks	
CP COL 9.5(1)	Repeaters shall be located such that a fire-induced failure of the repeater will not also cause failure of the other communications systems relied on for safe shutdown.	8.11.5	Conform	
CP COL 9.5(1)	Plant control equipment shall be designed so that the control equipment is not susceptible to radio frequency interferences from portable radios.	8.11.6	Conform	
CP COL 9.5(1)	Preoperational tests and periodic testing shall demonstrate that the frequencies used for portable radio communications will not affect actuation of protective relays or other electrical components.	8.11.7	Conform	
	A fire hazards analysis shall be conducted to determine the fire protection requirements for the facility.	9.1.1	Conform	See Appendix 9A.
	All fire protection systems, equipment, and installations shall be dedicated to fire protection purposes unless permitted by the following: (1) The requirement of 9.1.2 shall not apply to fire protection systems, equipment, and installations where in accordance with 9.4.10. (2) Fire Protection Systems shall be permitted to be used to provide redundant backup to nuclear safety-related systems provided that both the following criteria are met: (a) The fire protection systems shall meet the design basis requirements of the nuclear safety-related systems. (b) Fire protection systems used in 9.1.2(2)(a) shall be designed to handle both functions.	9.1.2	Conform	The fire protection system may provide backup functions for severe accident mitigation if the system is available.
	All fire protection equipment shall be listed or approved for its intended service.	9.1.3	Conform	

**Comanche Peak Nuclear Power Plant, Units 3 & 4
COL Application
Part 2, FSAR**

**Table 9.5.1-2R (Sheet 40 of 70)
CPNPP Units 3 & 4 Fire Protection Program Conformance with NFPA 804**

Standard Requirement	Paragraph	Conformance	Remarks	
CP COL 9.5(2)	The fire water supply shall be calculated on the basis of the largest expected flow rate for a period of 2 hours but shall not be less than 300,000 gal (1,135,500 L), and the following criteria also shall apply: (1) The flow rate shall be based on 500 gpm (1892.5 L/min) for manual hose streams plus the largest design demand of any sprinkler or fixed water spray system as determined in accordance with this standard, with NFPA 13, Standard for the Installation of Sprinkler Systems, or with NFPA 15, Standard for Water Spray Fixed Systems for Fire Protection. (2) The fire water supply shall be capable of delivering the design demand specified in 9.2.1(1) with the hydraulically least demanding portion of the fire main loop out of service.	9.2.1	Conform	See Subsection 9.5.1.2.2.
CP COL 9.5(2)	Two 100-percent [minimum of 300,000 gal (1,135,500 L) each] system capacity tanks shall be installed, and the following shall apply: (1) The tanks shall be interconnected such that fire pumps can take suction from either or both. (2) A failure in one tank or its piping shall not cause both tanks to drain. (3) The tanks shall be designed in accordance with NFPA 22, Standard for Water Tanks for Private Fire Protection. (4) Refill times for filling the water tanks shall not apply.	9.2.2	Conform	See Subsection 9.5.1.2.2.
CP COL 9.5(2)	The tanks shall not be supplied by an untreated, raw water source	9.2.3	Conform	See Subsection 9.5.1.2.2.
CP COL 9.5(2)	Fire pumps shall meet the requirements of NFPA 20, Standard for the Installation of Stationary Pumps for Fire Protection, and shall be automatic starting.	9.2.4.1	Conform	See Subsection 9.5.1.2.2.
CP COL 9.5(2)	Fire pumps shall be provided to ensure that 100% of the flow rate capacity will be available assuming failure of the largest pump.	9.2.4.2	Conform	See Subsection 9.5.1.2.2.

**Comanche Peak Nuclear Power Plant, Units 3 & 4
COL Application
Part 2, FSAR**

**Table 9.5.1-2R (Sheet 41 of 70)
CPNPP Units 3 & 4 Fire Protection Program Conformance with NFPA 804**

Standard Requirement	Paragraph	Conformance	Remarks	
CP COL 9.5(2)	Individual fire pump connections to the yard fire main loop shall be separated with sectionalizing valves between connections, and the following criteria also shall be met: (1) Each pump and its driver and controls shall be located in a room separated from the remaining fire pumps by a fire wall with a minimum rating of 3 hours. (2) The fuel for the diesel fire pump(s) shall be separated so that it does not provide a fire source exposing nuclear safety-related equipment.	9.2.4.3	Conform	See Subsection 9.5.1.2.2.
CP COL 9.5(2)	A method of automatic pressure maintenance of the fire protection system shall be provided independent of the fire pumps.	9.2.4.4	Conform	See Subsection 9.5.1.2.2.
CP COL 9.5(2)	Supervisory signals and visible indicators required by NFPA 20, Standard for the Installation of Stationary Pumps for Fire Protection, shall be received in the control room.	9.2.4.5	Conform	
CP COL 9.5(1)	All fire protection water supply and system control valves shall be under a periodic inspection program and shall be supervised by one of the following methods: (1) Electrical supervision with audible and visual signals in the MCR or another constantly attended location and monthly valve inspections. (2) Locking valves in their normal position and monthly valve inspections with keys made available only to authorized personnel.	9.3	Conform	
CP COL 9.5(2)	(3) Sealing valves in their normal positions and weekly valve inspections with this option utilized only where valves are located within fenced areas or under the direct control of the property owner. The underground yard fire main loop shall be installed to furnish anticipated water requirements, and the following criteria also shall be met: (1) The type of pipe and water treatment shall be design considerations, with tuberculation as one of the parameters. (2) Means for inspecting and flushing the systems shall be provided.	9.4.1	Conform	See Subsection 9.5.1.2.2.

**Comanche Peak Nuclear Power Plant, Units 3 & 4
COL Application
Part 2, FSAR**

**Table 9.5.1-2R (Sheet 42 of 70)
CPNPP Units 3 & 4 Fire Protection Program Conformance with NFPA 804**

Standard Requirement	Paragraph	Conformance	Remarks	
CP COL 9.5(2)	Approved visually indicating sectional control valves such as post indicator valves shall be provided to isolate portions of the main for maintenance or repair without simultaneously shutting off the supply to both primary and backup fire suppression systems.	9.4.2	Conform	See Subsection 9.5.1.2.2.
CP COL 9.5(2)	Valves shall be installed to allow isolation of outside hydrants from the fire main for maintenance or repair without interrupting the water supply to automatic or manual fire suppression systems.	9.4.3	Conform	See Subsection 9.5.1.2.3.
CP COL 9.5(2)	Sectional control valves shall allow maintaining independence of the individual loop around each unit, and the following also shall apply: (1) For such installations, common water supplies shall also be permitted to be utilized. (2) For multiple-reactor sites with widely separated plants [approaching 1 mi (1.6 km) or more], separate yard fire main loops shall be used.	9.4.4	Conform	See Subsection 9.5.1.2.3.
CP COL 9.5(2)	Outside manual hose installation shall provide an effective hose stream to any on-site location, and the following also shall apply: (1) Hydrants with individual hose gate valves shall be installed approximately every 250 ft. apart	9.4.5	Conform	See Subsection 9.5.1.2.3.
	on the yard main system. (2) A hose house equipped with hose and combination nozzle and other auxiliary equipment specified in NFPA 24, Standard for the Installation of Private Fire Service Mains and Their Appurtenances, shall be provided at intervals of not more than 1000 ft. along the yard main system. (3) Mobile means of providing hose and associated equipment, such as hose carts or trucks, shall be permitted in lieu of hose houses, and where provided, such mobile equipment shall be equivalent to that supplied by three hose houses.			

**Comanche Peak Nuclear Power Plant, Units 3 & 4
COL Application
Part 2, FSAR**

**Table 9.5.1-2R (Sheet 43 of 70)
CPNPP Units 3 & 4 Fire Protection Program Conformance with NFPA 804**

	Standard Requirement	Paragraph	Conformance	Remarks
CP COL 9.5(2)	One of the following criteria shall be met: (1) Threads compatible with those used by local fire departments shall be provided on all hydrants, hose couplings, and standpipe risers. (2) The fire departments shall be provided with adapters that allow interconnection between plant equipment and the fire department equipment.	9.4.6	Conform	See Subsection 9.5.1.2.3.
	Sprinkler systems and manual hose station standpipes shall have connections to the plant underground water main so that a single active failure or a crack in a moderate-energy line can be isolated so as not to impair both the primary and the backup fire suppression systems unless otherwise permitted by the following: (1) Alternatively, headers fed from each end shall be permitted inside buildings to supply both sprinkler and standpipe systems, provided steel piping and fittings meeting the requirements of ASME B31.1, Power Piping, are used for the headers (up to and including the first valve) supplying the sprinkler systems where such headers are part of the seismically analyzed hose standpipe system. (2) Where provided, such headers shall be considered an extension of	9.4.7	Conform	
	the yard main system. (3) Each sprinkler and standpipe system shall be equipped with an outside screw and yoke (OS&Y) gate valve or other approved shutoff valve.			
	For all power block buildings, Class III standpipe and hose systems shall be installed in accordance with NFPA 14, Standard for the Installation of Standpipe and Hose Systems.	9.4.8	Conform	
CP COL 9.5(2)	For all other buildings on-site, the requirements for standpipe and hose systems shall be appropriate for the hazard being protected.	9.4.9	Conform	

**Comanche Peak Nuclear Power Plant, Units 3 & 4
COL Application
Part 2, FSAR**

**Table 9.5.1-2R (Sheet 44 of 70)
CPNPP Units 3 & 4 Fire Protection Program Conformance with NFPA 804**

Standard Requirement	Paragraph	Conformance	Remarks
CP COL 9.5(1)	The proper type of hose nozzle to be supplied to each area shall be based on the fire hazards analysis, and the following criteria also shall apply: (1) The usual combination spray/straight-stream nozzle shall not be used in areas where the straight stream can cause unacceptable damage. (2) Approved, electrically safe fixed fog nozzles shall be provided at locations where high-voltage shock hazards exist. (3) All hose nozzles shall have shutoff capability.	9.4.10	Conform
	Provisions shall be made to supply water at least to standpipes and hose stations for manual fire suppression in all areas containing nuclear safety-related systems and components for safe shutdown in the event of a SSE.	9.4.11.1	Conform
	The piping system serving these hose stations shall be analyzed for safe shutdown and earthquake loading and shall be provided with supports that ensure pressure boundary integrity.	9.4.11.2	Conform
	The piping and valves for the portion of hose standpipe system affected by the functional requirement of 9.4.11.2 shall, as a	9.4.11.3	Conform
	minimum, satisfy the requirements of ASME B31.1, Power Piping.		
	The system shall be designed to flow a minimum of one Class III standpipe station in accordance with NFPA 14, Standard for the Installation of Standpipe and Hose Systems.	9.4.11.4	Conform
	Where the seismic required hose stations are cross-connected to essential seismic Category I water systems, the fire flow shall not degrade the essential water system requirements.	9.4.11.5	Conform
CP COL 9.5(3)	Portable and wheeled fire extinguishers shall be installed, inspected, maintained, and tested in accordance with NFPA 10, Standard for Portable Fire Extinguishers, unless otherwise permitted by 9.5.2.	9.5.1	Conform

**Comanche Peak Nuclear Power Plant, Units 3 & 4
COL Application
Part 2, FSAR**

**Table 9.5.1-2R (Sheet 45 of 70)
CPNPP Units 3 & 4 Fire Protection Program Conformance with NFPA 804**

Standard Requirement	Paragraph	Conformance	Remarks	
CP COL 9.5(3)	Where placement of extinguishers would result in required activities that are contrary to personnel radiological exposure concerns or nuclear safety-related concerns, fire extinguishers shall be permitted to be inspected at intervals greater than those specified in NFPA 10, Standard for Portable Fire Extinguishers, or consideration shall be given to locating the extinguishers outside high-radiation areas.	9.5.2	Conform	
	Automatic suppression systems shall be provided in all areas of the plant as required by the fire hazards analysis.	9.6.1	Conform	See Appendix 9A.
CP COL 9.5(2)	Except as modified in this chapter, the following NFPA standards shall be used: (1) NFPA 11, Standard for Low-, Medium-, and High-Expansion Foam. (2) NFPA 12, Standard on Carbon Dioxide Extinguishing Systems. (3) NFPA 13, Standard for the Installation of Sprinkler Systems.	9.6.2	Conform	
	(4) NFPA 15, Standard for Water Spray Fixed Systems for Fire Protection. (5) NFPA 16, Standard for the Installation of Foam-Water Sprinkler and Foam-Water Spray Systems. (6) NFPA 17, Standard for Dry Chemical Extinguishing Systems. (7) NFPA 214, Standard on Water-Cooling Towers. (8) NFPA 2001, Standard on Clean Agent Fire Extinguishing Systems.			
	The extinguishing systems chosen shall be based on the design parameters required as a result of the fire hazards analysis.	9.6.3	Conform	See Appendix 9A, conform except where RG 1.189 recommends protection not dictated by FHA.

**Comanche Peak Nuclear Power Plant, Units 3 & 4
COL Application
Part 2, FSAR**

**Table 9.5.1-2R (Sheet 46 of 70)
CPNPP Units 3 & 4 Fire Protection Program Conformance with NFPA 804**

Standard Requirement	Paragraph	Conformance	Remarks
Selection of extinguishing agent shall be based on all of the following: (1) Type or class of hazard. (2) Effect of agent discharge on critical equipment such as thermal shock, continued operability, water damage, overpressurization, or cleanup. (3) Health hazards.	9.6.4	Conform	
Each fire suppression system shall be equipped with approved alarming devices and annunciate in a constantly attended area.	9.6.5	Conform	
Fire signaling systems shall be provided in all areas of the plant as required by the fire hazards analysis.	9.7.1	Conform	Local alarm and MCR.
The requirements of this chapter shall constitute the minimum acceptable protective signaling system functions when used in conjunction with NFPA 72, National Fire Alarm Code.	9.7.2	Conform	
The signaling system's initiating device and signaling line circuits shall provide emergency operation for fire detection, fire alarm, and water flow alarm during a single break or a single ground fault.	9.7.3	Conform	
The fire signaling equipment used for fixed fire suppression systems shall give audible and visual alarm and system trouble annunciation in the plant control room for the power block buildings, and the following shall apply: (1) Local alarms shall be provided. (2) Other fire alarm signals from other buildings shall be permitted to annunciate at the control room or other locations that are constantly attended.	9.7.4	Conform	
Audible signaling appliances shall meet the following criteria: (1) They shall produce a distinctive sound, used for no other purpose. (2) They shall be located and installed so that the alarm can be heard above ambient noise levels.	9.7.5	Conform	
Plant control room or plant security personnel shall be trained in the operation of all fire signaling systems used in the plant, including the ability to identify any alarm zone or fire protection system that is operating.	9.7.6	Conform	

CP COL 9.5(1)

**Comanche Peak Nuclear Power Plant, Units 3 & 4
COL Application
Part 2, FSAR**

**Table 9.5.1-2R (Sheet 47 of 70)
CPNPP Units 3 & 4 Fire Protection Program Conformance with NFPA 804**

Standard Requirement	Paragraph	Conformance	Remarks
Fire signaling equipment and actuation equipment for the release of fixed fire suppression systems shall be connected to power supply sources in accordance with the requirements of NFPA 72, National Fire Alarm Code, and shall be routed outside the area to be protected.	9.7.7	Conform	
Manual fire alarm boxes shall be installed as required by the fire hazards analysis, and the following criteria also shall be met: (1) Where manual release devices are installed for the purpose of releasing an extinguishing agent in a fixed fire suppression system, the manual releases shall be marked for that purpose. (2) The manual release device circuits shall be routed outside the area protected by the fixed extinguishing system.	9.7.8	Conform	
All signals shall be permanently recorded in accordance with NFPA 72, National Fire Alarm Code.	9.7.9	Conform	
Automatic fire detectors shall be selected and installed in accordance with all of the following: (1) NFPA 72, National Fire Alarm Code. (2) Design parameters required as a result of the fire hazards analysis of the plant area. (3) Additional requirements of this standard.	9.8	Conform	
The identification and selection of fire protection systems shall be based on the fire hazards analysis.	10.1.1	Conform	See Appendix 9A.
This chapter identifies fire and explosion hazards in advanced light water reactor plants and specifies the protection criteria that shall be used unless the fire hazards analysis indicates otherwise.	10.1.2	Informational Statement	
Fire protection for the primary and secondary containment areas shall be provided for hazards identified by the fire hazards analysis.	10.2.1	Conform	See Appendix 9A.
Operation of the fire protection systems shall not compromise the integrity of the containment or other safety-related systems.	10.2.1.1	Conform	

**Comanche Peak Nuclear Power Plant, Units 3 & 4
COL Application
Part 2, FSAR**

**Table 9.5.1-2R (Sheet 48 of 70)
CPNPP Units 3 & 4 Fire Protection Program Conformance with NFPA 804**

Standard Requirement	Paragraph	Conformance	Remarks
Fire protection systems in the containment areas shall function in conjunction with total containment requirements such as ventilation and control of containment liquid and gaseous release.	10.2.1.2	Conform	
Inside primary containment, fire detection systems shall be provided for each fire hazard identified in the fire hazards analysis.	10.2.1.3	Conform	
The type of detection used and the location of the detectors shall be the most suitable for the particular type of fire hazard identified by the fire hazards analysis.	10.2.1.4	Conform	
A general area fire detection capability shall be provided in the primary containment as a backup for the hazard detection described in 10.2.1.4 by the installation of smoke or heat detectors compatible with the radiation environment in accordance with NFPA 72, National Fire Alarm Code.	10.2.1.5	Conform	
Standpipe and hose stations shall be installed inside containment. Standpipe and hose stations inside containment shall be permitted to be connected to a high-quality water supply of the required quantity and pressure other than the fire main loop if plant-specific features prevent extending the fire main supply inside containment.	10.2.1.6	Conform	
For inerted primary containment, standpipe and hose stations shall be permitted to be placed outside the primary containment, with hose no longer than 100 ft., to reach any location inside the primary containment with a 30 ft. effective hose stream.	10.2.1.7	NA	US-APWR containment is not inerted.
Reactor coolant pumps with an external lubrication system shall be provided with an oil collection system.	10.2.1.8	Conform	
The oil collection system shall be so designed, engineered, and installed that failure of the oil collection system will not lead to a fire during normal operations or off-normal conditions such as accident conditions or earthquakes.	10.2.1.9	Conform	

**Comanche Peak Nuclear Power Plant, Units 3 & 4
COL Application
Part 2, FSAR**

**Table 9.5.1-2R (Sheet 49 of 70)
CPNPP Units 3 & 4 Fire Protection Program Conformance with NFPA 804**

Standard Requirement	Paragraph	Conformance	Remarks
The oil collection systems shall be capable of collecting oil from all potential pressurized and unpressurized leakage sites in the reactor coolant pump oil systems, and the following criteria also shall apply: (1) Leakage shall be collected and drained to a vented closed container that can hold the entire oil system inventory.	10.2.1.10	Conform	
(2) Leakage points to be protected shall include the following, where such features exist on the reactor coolant pumps: (a) Lift pump and piping. (b) Overflow lines. (c) Oil cooler. (d) Oil fill. (e) Drain lines and plugs. (f) Flanged connections on oil lines. (g) Oil reservoirs. (3) The drain line shall be large enough to accommodate the largest potential oil leak.			
CP COL 9.5(1) Management procedures and controls necessary to ensure fire protection for fire hazards introduced during maintenance and refueling shall be provided.	10.2.2.1	Conform	See Subsection 9.5.1.6.
Backup fire suppression shall be provided so that total reliance is not placed on a single fire suppression system.	10.2.2.2	Conform	
CP COL 9.5(3) Self-contained breathing apparatus meeting the following criteria shall be provided near the containment entrance for fire-fighting and damage control personnel: (1) The units shall be independent of any breathing apparatus or air supply systems provided for general plant activities. (2) The units shall be marked as emergency equipment.	10.2.2.3	Conform	
The control room complex (including kitchen, office spaces, etc.) shall be protected against disabling fire damage and shall be separated from other areas of the plant by floors, walls, ceilings, and roofs having a minimum fire resistance rating of 3 hours.	10.3.1	Conform	

**Comanche Peak Nuclear Power Plant, Units 3 & 4
COL Application
Part 2, FSAR**

**Table 9.5.1-2R (Sheet 50 of 70)
CPNPP Units 3 & 4 Fire Protection Program Conformance with NFPA 804**

Standard Requirement	Paragraph	Conformance	Remarks
Peripheral rooms in the control room complex shall have an automatic water-based suppression system, where required by the fire hazards analysis, and shall be separated from the control room by noncombustible construction with a	10.3.2	Conform	
minimum fire resistance rating of 1 hour.			
Ventilation system openings between the control room and the peripheral rooms shall have automatic smoke dampers installed that close on operation of the fire detection and fire suppression systems.	10.3.3	Conform	
Manual fire-fighting capability shall be provided for both of the following: (1) Fires originating within a cabinet, console, or connecting cables. (2) Exposure fires involving combustibles in the general room area.	10.3.4	Conform	
Portable Class A and Class C fire extinguishers shall be located in the control room, and a fire hose station shall be installed outside the control room.	10.3.5	Conform	
CP COL 9.5(1) Nozzles that are compatible with the hazards and the equipment in the control room shall be provided for the fire hose stations.	10.3.6	Conform	See Subsection 9.5.1.6.
CP COL 9.5(1) The choice of nozzles shall satisfy fire-fighting requirements and electrical safety requirements and shall minimize physical damage to electrical equipment from hose stream impingement.	10.3.7	Conform	See Subsection 9.5.1.6.
Smoke detectors shall be provided in the control room complex, the electrical cabinets, and the consoles.	10.3.8	Conform	
If redundant safe shutdown equipment is located in the same control room cabinet or console, the cabinet or console shall be provided with internal separation (noncombustible barriers) to limit the damage to one safety division.	10.3.9	NA	US-APWR provides separation of safety trains and remote shutdown console.
CP COL 9.5(3) Breathing apparatus for the control room operators shall be available.	10.3.10	Conform	

**Comanche Peak Nuclear Power Plant, Units 3 & 4
COL Application
Part 2, FSAR**

**Table 9.5.1-2R (Sheet 51 of 70)
CPNPP Units 3 & 4 Fire Protection Program Conformance with NFPA 804**

Standard Requirement	Paragraph	Conformance	Remarks
The outside air intakes for the control room ventilation system shall be provided with smoke detection capability to alarm in the control room and enable manual isolation of the control room ventilation system, thus preventing smoke from entering the control room.	10.3.11	Conform	
Venting of smoke produced by a fire in the control room by means of the normal ventilation system shall be permitted to be acceptable if provision is made for isolation of the recirculation portion of the normal ventilation system.	10.3.12	NA	Smoke removal system designed and installed.
Manually operated venting of the control room shall be available to the operators.	10.3.13	Conform	
All cables that enter the control room shall terminate in the control room, and the following criteria also shall apply: (1) No cabling shall be routed through the control room from one area to another. (2) Cables in spaces underfloor and in above-ceiling spaces shall meet the separation criteria necessary for fire protection.	10.3.14	Conform	
Air-handling functions shall be ducted separately from cable runs in such spaces (underfloor and above ceiling, such spaces shall not be used as air plenums for ventilation of the control room).	10.3.15	Conform	
Fully enclosed electrical raceways located in such underfloor and ceiling spaces, if over 1 ft ² (0.09 m ²) in cross-sectional area, shall have automatic fire suppression inside.	10.3.16	Conform	
Area automatic fire suppression shall be provided for underfloor and ceiling spaces if used for cable runs unless all cable is run in 4 in. (101.6 mm) or smaller steel conduit or cables are in fully enclosed raceways internally protected by automatic fire suppression.	10.3.17	Conform	

**Comanche Peak Nuclear Power Plant, Units 3 & 4
COL Application
Part 2, FSAR**

**Table 9.5.1-2R (Sheet 52 of 70)
CPNPP Units 3 & 4 Fire Protection Program Conformance with NFPA 804**

Standard Requirement	Paragraph	Conformance	Remarks
The cable spreading room shall have an automatic fixed water-based suppression system, and the following criteria also shall be met: (1) The location of sprinklers or spray nozzles shall protect cable tray arrangements to ensure water coverage for areas that could present exposure fire hazards to the cable raceways. (2) Automatic sprinkler systems shall be designed for a density of 0.30 gpm/ft ² (12.2 L/min m ²) over the most remote 2500 ft ² (232.2 m ²).	10.4.1.1	NA	The US-APWR does not use a cable spreading room. The MCR sub floor area is provided with a very early warning smoke detection system and a clean agent environmentally friendly gaseous suppression system.
Suppression systems shall be zoned to limit the area of protection to that which the drainage system can handle with any two adjacent systems actuated.	10.4.1.2	Conform	
Deluge and water spray systems shall be hydraulically designed with each zone calculated with the largest adjacent zone flowing.	10.4.1.3	Conform	
Cable spreading rooms shall be provided with all of the following: (1) At least two remote and separate entrances for access by the fire brigade personnel. (2) Aisle separation between tray stacks at least 3 ft. wide and 8 ft. high. (3) Hose stations and portable fire extinguishers installed outside the room. (4)* Area smoke detection.	10.4.1.4	NA	The US-APWR does not employ a cable spreading room.
Cable tunnels shall be provided with smoke detection.	10.4.2.1	N/A	Cable tunnels not employed for US-APWR.
Cable tunnels shall be provided with automatic fixed suppression systems.	10.4.2.2.1	N/A	
Automatic sprinkler systems shall be designed for a density of 0.30 gpm/ft ² (12.2 L/min·m ²) for the most remote 100 linear ft. of cable tunnel up to the most remote 2500 ft ² .	10.4.2.2.2	N/A	
The location of sprinklers or spray nozzles shall protect cable tray arrangements and possible transient combustibles to ensure water coverage for areas that could present exposure fire hazards to the cable raceways.	10.4.2.2.3	N/A	

**Comanche Peak Nuclear Power Plant, Units 3 & 4
COL Application
Part 2, FSAR**

**Table 9.5.1-2R (Sheet 53 of 70)
CPNPP Units 3 & 4 Fire Protection Program Conformance with NFPA 804**

Standard Requirement	Paragraph	Conformance	Remarks
Deluge sprinkler systems or deluge spray systems shall meet the following criteria: (1) They shall be zoned to limit the area of protection to that which the drainage system can handle with any two adjacent systems actuated. (2) They shall be hydraulically designed with each zone calculated with the largest adjacent zone flowing.	10.4.2.2.4	N/A	
Cables shall be designed to allow wetting of undamaged cables with water supplied by the fire suppression system without electrical faulting.	10.4.2.3	Conform	
Cable tunnels over 50 ft. long shall be provided with all of the following: (1) At least two remote and separate entrances for access by the fire brigade personnel (2) An aisle separation between tray stacks at least 3 ft. wide and 8 ft. high (3) Hose stations and portable fire extinguishers installed outside the tunnel	10.4.2.4	N/A	
Cable tray fire breaks shall be installed every 20 ft. for vertical cable trays that rise over 30 ft., and the following criteria also shall be met: (1) Access to cable shafts shall be provided every 40 ft. with the topmost access within 20 ft. of the cable shaft ceiling. (2) Automatic sprinkler protection and smoke detection shall be provided at the ceiling of the vertical shaft.	10.4.3	Conform	
Computer and communications rooms shall meet the applicable requirements of NFPA 75, Standard for the Protection of Information Technology Equipment.	10.5	Conform	
Smoke detection shall be provided and shall alarm in both the control room and locally, and the following criteria also shall apply: (1) Cables entering the safety-related switchgear rooms shall terminate in the switchgear room. (2) The safety-related switchgear rooms shall not be used for other purposes. (3) Fire hose stations and portable fire extinguishers shall be readily available outside the area.	10.6.1	Conform	

**Comanche Peak Nuclear Power Plant, Units 3 & 4
COL Application
Part 2, FSAR**

**Table 9.5.1-2R (Sheet 54 of 70)
CPNPP Units 3 & 4 Fire Protection Program Conformance with NFPA 804**

Standard Requirement	Paragraph	Conformance	Remarks
Equipment shall be located to facilitate fire fighting, and the following criteria also shall be met: (1) Drains shall be provided to prevent water accumulation from damaging safety-related equipment. (2) Remote manually actuated ventilation shall be provided for smoke removal when manual fire suppression is needed.	10.6.2	Conform	
Battery rooms shall be provided with ventilation to limit the concentration of hydrogen to 2% by volume, and loss of ventilation shall alarm in the control room.	10.7.1	Conform	
Safety-related battery rooms shall be protected against fires and explosions, and the following criteria also shall apply: (1) Battery rooms shall be separated from other areas of the plant by fire barriers having a 1-hour minimum rating. (2) Direct current switchgear and inverters shall not be located in the battery rooms. (3) Fire detection shall be provided. (4) Fire hose stations and portable fire extinguishers shall be available outside the room.	10.7.2	Conform	
The T/B shall be separated from adjacent structures containing safety-related equipment by fire-resistive barriers having a minimum 3-hour rating, and the following criteria also shall apply: (1) The fire barriers shall be designed so that the barrier will remain in place even in the event of complete collapse of the turbine structure. (2) Openings and penetrations shall be minimized in the fire barrier and shall not be located where turbine oil systems or generator hydrogen cooling systems create a direct fire exposure hazard to the fire barrier. (3) Smoke and heat removal systems shall be provided in accordance with 8.4.3. (4) For those plants provided with complete automatic sprinkler protection at the roof level, smoke and heat removal systems shall not be required.	10.8.1	Conform	

**Comanche Peak Nuclear Power Plant, Units 3 & 4
COL Application
Part 2, FSAR**

**Table 9.5.1-2R (Sheet 55 of 70)
CPNPP Units 3 & 4 Fire Protection Program Conformance with NFPA 804**

Standard Requirement	Paragraph	Conformance	Remarks
All areas beneath the turbine generator operating floor shall be protected by an automatic sprinkler or foam-water sprinkler system meeting the following criteria: (1) The sprinkler system beneath the turbine generator shall be designed around obstructions from structural members and piping. (2) The sprinkler system shall be designed to a minimum density of 0.30 gpm/ft ² (12.2 L/min·m ²) over a minimum application of 5000 ft ² (464.5 m ²).	10.8.2.1	Conform	
Foam-water sprinkler systems installed in place of automatic sprinklers described in 10.8.2.1 shall be designed in accordance with NFPA 16, Standard for the Installation of Foam-Water Sprinkler and Foam-Water Spray Systems, and the design densities specified in 10.8.2.1.	10.8.2.2	NA	No foam-water sprinkler systems are used for the US-APWR.
Electrical equipment in the area covered by a water or foam system shall be of the enclosed type or	10.8.2.3	Conform	Sensitive equipment is protected from water spray damage.
otherwise protected to minimize water damage in the event of system operation.			
Automatic fixed suppression systems shall be provided for all turbine generator and exciter bearings.	10.8.3.1	Conform	
If closed-head water spray systems utilizing directional nozzles in accordance with NFPA 15, Standard for Water Spray Fixed Systems for Fire Protection, are provided, bearing protection shall be provided for a minimum density of 0.30 gpm/ft ² (12.2 L/min·m ²) over the protected area.	10.8.3.2	N/A	
Accidental water discharge on bearing points and hot turbine parts shall be considered. If necessary, these areas shall be permitted to be protected by shields and encasing insulation with metal covers.	10.8.3.3	N/A	

**Comanche Peak Nuclear Power Plant, Units 3 & 4
COL Application
Part 2, FSAR**

**Table 9.5.1-2R (Sheet 56 of 70)
CPNPP Units 3 & 4 Fire Protection Program Conformance with NFPA 804**

Standard Requirement	Paragraph	Conformance	Remarks
Lubricating oil lines above the turbine operating floor shall be protected with an automatic sprinkler system to a minimum density of 0.30 gpm/ft ² (12.2 L/min·m ²) that covers those areas subject to oil accumulation, including the area within the turbine lagging (skirt).	10.8.4	Conform	
Lubricating oil reservoirs and handling equipment shall be protected in accordance with 10.8.2.1.	10.8.5	Conform	
If the lubricating oil reservoir specified in 10.8.5 is elevated, sprinkler protection shall be extended to protect the area beneath the reservoir.	10.8.6	Conform	
The following shall apply to protection associated with shaft-driven ventilation systems: (1) Where shaft-driven ventilation systems are not used, the area inside a directly connected exciter housing shall be protected with an automatic fire suppression system.	10.8.7	Conform	
(2) Where shaft-driven ventilation systems are used, an automatic preaction sprinkler system providing a density of 0.30 gpm/ft ² (12.2 L/min·m ²) over the entire area shall be provided.			
Clean- or dirty-oil storage areas shall be protected based on the fire risk evaluation, and the designer shall include, as a minimum, the installation of fixed automatic fire protection systems and the ventilation and drainage requirements in Chapter 8.	10.8.8	Conform	See Appendix 9A.
Bulk hydrogen systems supplying one or more generators shall have automatic valves located at the supply and operable by "dead man"-type controls at the generator fill point(s) or operable from the control room.	10.8.9.1.1	Conform	
As an alternative to the requirement of 10.8.9.1.1, vented guard piping shall be permitted to be used inside the building to protect runs of hydrogen piping.	10.8.9.1.2	Conform	
A flanged spool piece or equivalent arrangement shall be provided to facilitate the separation of hydrogen supply when the generator is open for maintenance.	10.8.9.1.3	Conform	

**Comanche Peak Nuclear Power Plant, Units 3 & 4
COL Application
Part 2, FSAR**

**Table 9.5.1-2R (Sheet 57 of 70)
CPNPP Units 3 & 4 Fire Protection Program Conformance with NFPA 804**

Standard Requirement	Paragraph	Conformance	Remarks
Control room alarms shall be provided to indicate abnormal gas pressure, temperature, and percentage of hydrogen in the generator.	10.8.9.1.4	Conform	
The generator hydrogen dump valve and hydrogen-detaining equipment shall meet the following criteria: (1) They shall be arranged to vent directly to a safe outside location. (2) The dump valve shall be remotely operable from the control room or from an area accessible during a machine fire.	10.8.9.1.5	Conform	
An excess-flow check valve shall be provided for the bulk supply hydrogen piping.	10.8.9.1.6	Conform	
Redundant hydrogen seal oil pumps with separate power supplies shall be provided for reliability of seal oil supply.	10.8.9.2.1	Conform	
Where feasible, electrical circuits to redundant pumps shall be run in buried conduit or provided with fire-retardant coating if exposed in the area of the turbine generator, to minimize the possibility of loss of both pumps as a result of a turbine generator fire.	10.8.9.2.2	Conform	
Hydrogen seal oil units shall be protected as follows: (1) In accordance with 10.8.2 (2) By an automatic, open-head water spray system providing a density of 0.30 gpm/ft ² (12.2 L/min·m ²) over the hydrogen seal area	10.8.9.2.3	Conform	
Curbing or drainage or both shall be provided for the hydrogen seal oil unit in accordance with Chapter 8, Section 8.5.	10.8.9.2.4	Conform	
Hydrogen lines in safety-related areas shall meet one of the following criteria: (1) They shall be designed to seismic Class I requirements or sleeved such that the outer pipe is directly vented to the outside. (2) They shall be equipped with excess-flow valves so that, in case of a line break, the hydrogen concentration in the affected areas will not exceed 2%.	10.8.9.3.1	Conform	

**Comanche Peak Nuclear Power Plant, Units 3 & 4
COL Application
Part 2, FSAR**

**Table 9.5.1-2R (Sheet 58 of 70)
CPNPP Units 3 & 4 Fire Protection Program Conformance with NFPA 804**

Standard Requirement	Paragraph	Conformance	Remarks
Hydrogen lines or sensing lines containing hydrogen shall not be piped into or through the control room.	10.8.9.3.2	Conform	
The hydraulic control system shall use a listed fire-resistant fluid.	10.8.10	Conform	
Turbine lubricating oil reservoirs shall be provided with vapor extractors, which shall be vented to an outside location.	10.8.11.1	Conform	
Curbing or drainage or both shall be provided for the turbine lubricating oil reservoir in accordance with Chapter 8, Section 8.5.	10.8.11.2	Conform	
All oil pipe serving the turbine generator shall be designed and installed to minimize the possibility of an oil fire in the event of severe turbine vibration.	10.8.11.3	Conform	
Piping design and installation shall include all of the following measures: (1) Welded construction. (2)* Guard pipe construction with the pressure feed line located inside the return line or in a separate shield pipe drained to the oil reservoir. (3) Routing oil piping clear of or below steam piping or metal parts. (4) Insulating with impervious lagging for steam piping or hot metal parts under or near oil piping or turbine bearing points.	10.8.11.4	Conform	
Cable for operation of the lubricating oil pumps shall be protected from fire exposure, and the following criteria also shall apply: (1) Where feasible, electrical circuits to redundant pumps shall be run in buried conduit. (2) Protection shall be permitted to consist of separation of cables for ac and dc oil pumps or 1-hour fire-resistive coating (derating of cable shall be considered).	10.8.11.5	Conform	
The installation and operation of standby emergency diesel generators and combustion turbines shall be in accordance with NFPA 37, Standard for the Installation and Use of Stationary Combustion Engines and Gas Turbines, unless otherwise permitted by 10.9.2.	10.9.1	Conform	

**Comanche Peak Nuclear Power Plant, Units 3 & 4
COL Application
Part 2, FSAR**

**Table 9.5.1-2R (Sheet 59 of 70)
CPNPP Units 3 & 4 Fire Protection Program Conformance with NFPA 804**

Standard Requirement	Paragraph	Conformance	Remarks
The requirement of 10.9.1 shall not apply to automatic shutdown and remote shutdown features, which shall be governed by nuclear-safety requirements.	10.9.2	Conform	
Standby emergency diesel generators and combustion turbines located within main plant structures shall be protected as follows: (1) They shall be protected by automatic sprinkler, water spray, or foam-water sprinkler systems. (2) The sprinkler and water spray protection systems shall be designed for a 0.25 gpm/ft ² (10.19 L/min·m ²) density over the entire area.	10.9.3	Conform	
Fire detection shall be provided to alarm and annunciate in the control room and to alarm locally, and the following criteria also shall be met: (1) Fire hose stations and portable fire extinguishers shall be located outside the area. (2) Drainage for fire-fighting water and means for local manual venting of smoke shall be provided.	10.9.4	Conform	
A day tank shall be permitted in standby emergency diesel generator and combustion turbine rooms if the day tank is located in a diked enclosure that has sufficient capacity to hold 110% of the contents of the day tank or is drained to a safe location.	10.9.5	Conform	
Diesel fuel oil storage tanks shall not be located inside buildings containing other nuclear safety-related equipment, and the following criteria also shall apply: (1) If aboveground tanks are used, they shall be located at least 50 ft. from any building, or if within 50 ft., they shall be separated from the building by a fire barrier having a minimum 3-hour rating. (2) Potential oil spills shall be confined or directed away from buildings containing safety-related equipment.	10.10.1	Conform	Gas turbines are used for US-APWR. The gas turbine 7-day fuel storage
Aboveground tanks shall be provided with automatic fire suppression systems.	10.10.2	N/A	

**Comanche Peak Nuclear Power Plant, Units 3 & 4
COL Application
Part 2, FSAR**

**Table 9.5.1-2R (Sheet 60 of 70)
CPNPP Units 3 & 4 Fire Protection Program Conformance with NFPA 804**

Standard Requirement	Paragraph	Conformance	Remarks
Nuclear safety-related pump rooms shall be protected by fire detection systems, and the following criteria also shall apply: (1) Automatic fire suppression systems shall be provided unless the fire hazards analysis determines that fire suppression is not required. (2) Fire hose stations and fire extinguishers shall be readily accessible.	10.11	Conform	
Fire extinguishers shall be located within the new-fuel area, and the following criteria also shall be met: (1) Fire hose stations shall be located as determined by the fire hazards analysis to facilitate access and use for fire-fighting operations. (2) Fire detection systems shall be provided. (3) Combustible material shall be limited to the minimum necessary for operation in the new-fuel area.	10.12.1	Conform	
The storage configuration of new fuel shall always be maintained as to preclude criticality for any water density that could occur during fire water application.	10.12.2	Conform	
Protection for the spent-fuel pool area shall be provided by fire hose stations and fire extinguishers.	10.13.1	Conform	
Fire detection shall be provided in the area.	10.13.2	Conform	Linear Beam Detectors are provided for this large room.
Fire barriers, fire detection, and automatic fire suppression shall be provided as determined by the fire hazards analysis.	10.14.1	Conform	See Appendix 9A.
Manual ventilation control to assist in smoke removal shall be provided if necessary for manual fire fighting.	10.14.2	Conform	See subsection 9.5.1.6. Fire brigade has portable smoke removal equipment.
Storage tanks that supply water for fire-safe shutdown shall be protected from the effects of an exposure fire.	10.15.1	Conform	
Combustible materials shall not be stored next to these tanks.	10.15.2	Conform	

CP COL 9.5(3)

**Comanche Peak Nuclear Power Plant, Units 3 & 4
COL Application
Part 2, FSAR**

**Table 9.5.1-2R (Sheet 61 of 70)
CPNPP Units 3 & 4 Fire Protection Program Conformance with NFPA 804**

Standard Requirement	Paragraph	Conformance	Remarks	
CP COL 9.5(2)	Record storage areas shall be located and protected in accordance with NFPA 232, Standard for the Protection of Records.	10.16.1	Conform	
CP COL 9.5(2)	Record storage areas shall not be located in safety-related areas and shall be separated from safety-related areas by fire barriers having a minimum 3-hour rating.	10.16.2	Conform	Record storage inside plant is protected with 3-hour fire walls. Primary record storage is in office building spatially separated from plant.
CP COL 9.5(2)	Cooling towers shall be of noncombustible or limited-combustible construction.	10.17.1	Conform	UHS cooling towers of noncombustible construction.
CP COL 9.5(2)	Cooling towers shall be located such that a fire in the cooling tower will not adversely affect safety-related systems or equipment.	10.17.2	Conform	Cooling towers for the Turbine side are located away from plant. UHS cooling towers are safety-related and of noncombustible construction.
CP COL 9.5(2)	The following criteria also shall be met: (1) Cooling towers shall be of noncombustible construction when the basin is used as the ultimate heat sink. (2) If cooling towers are of combustible construction, the following criteria shall be met: (a) They shall be protected by automatic sprinklers or water spray systems in accordance with NFPA 214, Standard on Water-Cooling Towers. (b) They shall be located so that they do not affect safety-related systems or equipment in the event of a fire.	10.17.3	Conform	
CP COL 9.5(2)	Gas cylinder storage locations or the fire protection systems that serve those safety-related areas shall not be in areas that contain or expose safety-related equipment.	10.18	Conform	
	Unused ion exchange resins shall not be stored in areas that contain or expose safety-related systems or equipment.	10.19	Conform	

**Comanche Peak Nuclear Power Plant, Units 3 & 4
COL Application
Part 2, FSAR**

**Table 9.5.1-2R (Sheet 62 of 70)
CPNPP Units 3 & 4 Fire Protection Program Conformance with NFPA 804**

Standard Requirement	Paragraph	Conformance	Remarks
	10.20	Conform	
CP COL 9.5(2)	10.21	Conform	Warehouse is sprinkler protected.
CP COL 9.5(2)	10.22.1	Conform	Automatic wet-pipe sprinkler system protection is provided.
CP COL 9.5(2)	10.22.2	Conform	
CP COL 9.5(1)	10.23.1	Conform	See Appendix 9A. A 3-hour fire barrier separates the transformers and the turbine building.
CP COL 9.5(1)	10.23.1.1	Conform	A one-hour fire barrier is provided between transformers.
CP COL 9.5(1)	10.23.1.2	Conform	Spill confinement and oil separation is provided for transformers.
CP COL 9.5(1)	10.23.2	Conform	See Appendix 9A. An automatic water spray system following the
			guidance of NFPA 15 is provided for these transformers.
			NFPA 15, Standard for Water Spray Fixed Systems for Fire Protection, or foam-water spray systems in accordance with NFPA 16, Standard for the Installation of Foam-Water Sprinkler and Foam-Water Spray Systems.

**Comanche Peak Nuclear Power Plant, Units 3 & 4
COL Application
Part 2, FSAR**

**Table 9.5.1-2R (Sheet 63 of 70)
CPNPP Units 3 & 4 Fire Protection Program Conformance with NFPA 804**

Standard Requirement	Paragraph	Conformance	Remarks
	10.23.3	Conform	
	10.23.4	Conform	
CP COL 9.5(2)	10.24.1	Conform	Auxiliary Boiler is in a separate building separated from safety-related structures.
	10.24.2	N/A	
	10.24.3	N/A	
CP COL 9.5(2)	10.25	Conform	
CP COL 9.5(2)	10.26.1	Conform	Simulator is not located in the plant area.
CP COL 9.5(2)	10.26.2	Conform	
	10.27	Conform	

**Comanche Peak Nuclear Power Plant, Units 3 & 4
COL Application
Part 2, FSAR**

**Table 9.5.1-2R (Sheet 64 of 70)
CPNPP Units 3 & 4 Fire Protection Program Conformance with NFPA 804**

Standard Requirement	Paragraph	Conformance	Remarks	
CP COL 9.5(2)	Intake structures shall be of noncombustible construction and shall be provided with automatic sprinkler protection.	10.28	Conform	
CP COL 9.5(1)	Consideration of fire protection shall include safety to life and potential for delays in construction schedules and plant startup, as well as protection of property.	11.1	Conform	
CP COL 9.5(1)	The responsibility for fire protection for the entire site during the construction period shall be defined.	11.2.1	Conform	See Subsection 9.5.1.6.
CP COL 9.5(1)	The administrative responsibilities shall be to develop, implement, and periodically update as necessary the measures outlined in this standard.	11.2.2	Conform	See Subsection 9.5.1.6.
CP COL 9.5(1)	The responsibility for fire protection programs among various organizations onsite shall be delineated.	11.2.3	Conform	See Subsection 9.5.1.6.
CP COL 9.5(1)	The fire protection program to be followed and the owner's right to administration and enforcement shall be established.	11.2.4	Conform	See Subsection 9.5.1.6.
CP COL 9.5(1)	The fire protection program shall include a fire risk evaluation of the construction site and construction activities.	11.2.5	Conform	
CP COL 9.5(1)	Written procedures in accordance with Chapter 5 shall be established for the new construction site, including major construction projects in existing plants.	11.2.6	Conform	See Subsection 9.5.1.6.
CP COL 9.5(1)	Security guard service, including recorded rounds, shall be provided through all areas of construction during times when construction activity is not in progress.	11.2.7	Conform	
CP COL 9.5(1)	Construction schedules shall be coordinated so that the planned permanent fire protection systems are installed and placed in service.	11.2.8	Conform	
CP COL 9.5(1)	Construction and installation of fire barriers and fire doors shall be given priority in the construction schedule.	11.2.9	Conform	

**Comanche Peak Nuclear Power Plant, Units 3 & 4
COL Application
Part 2, FSAR**

**Table 9.5.1-2R (Sheet 65 of 70)
CPNPP Units 3 & 4 Fire Protection Program Conformance with NFPA 804**

Standard Requirement	Paragraph	Conformance	Remarks
CP COL 9.5(1)	Prior to clearing forest and brush-covered areas, the following actions shall be taken: (1) The owner shall ensure that a written fire control plan is prepared and that fire-fighting tools and equipment are made available as required by NFPA 1143, Standard for Wildland Fire Management. (2) Contact shall be made with local fire and forest agencies for current data on restrictions and fire potential and to arrange for necessary permits.	11.3.1.1	Conform
CP COL 9.5(1)	The following shall apply to all construction vehicles and engine-driven portable equipment: (1) They shall be equipped with effective spark arresters. (2) Vehicles equipped with catalytic converters shall be prohibited from wooded and heavily vegetated areas.	11.3.1.2	Conform
CP COL 9.5(1)	Fire tools and equipment shall be distinctly marked and used for fire emergencies only.	11.3.1.3	Conform
CP COL 9.5(1)	Each site utility vehicle shall be equipped with at least one fire-fighting tool, portable fire extinguisher, or backpack pump filled with 4 gal to 5 gal (15 L to 19 L) of water.	11.3.1.4	Conform
CP COL 9.5(1)	Cut trees, brush, and other combustible spoil shall be disposed of.	11.3.1.5	Conform
CP COL 9.5(1)	Where it is necessary to dispose of combustible waste by onsite burning, designated burning areas shall be established with the approval of the owner and shall be in compliance with federal, state, and local regulations and guidelines. The contractor shall coordinate burning with the agencies responsible for monitoring fire danger in the area and shall obtain all appropriate permits prior to the start of work.	11.3.1.6	Conform
CP COL 9.5(1)	All structures that are to be retained, as part of the completed plant shall be constructed of materials as indicated in Chapter 10 and in accordance with other applicable sections in this standard.	11.4.1	Conform

**Comanche Peak Nuclear Power Plant, Units 3 & 4
COL Application
Part 2, FSAR**

**Table 9.5.1-2R (Sheet 66 of 70)
CPNPP Units 3 & 4 Fire Protection Program Conformance with NFPA 804**

Standard Requirement	Paragraph	Conformance	Remarks
CP COL 9.5(1)	Construction warehouses, offices, trailers, sheds, and other facilities for the storage of tools and materials shall be located with consideration of their exposure to major plant buildings or other important structures.	11.4.2	Conform
CP COL 9.5(1)	A fire risk evaluation shall be performed.	11.4.3	Conform
CP COL 9.5(1)	Warehouses that contain high-value equipment (as defined by the individual responsible for fire prevention and fire protection) or contents the loss of which or damage to would cause a delay in startup dates of the completed plant shall meet the following criteria: (1) They shall be arranged and protected as indicated in 11.4.4.1 through 11.4.4.4. (2) Although some of these structures are considered to be temporary and will be removed on completion of the plant, the fire and loss potential shall be evaluated and protection provided where warranted.	11.4.4	Conform
CP COL 9.5(1)	Building construction materials shall be noncombustible or limited-combustible.	11.4.4.1	Conform
CP COL 9.5(1)	Automatic sprinkler systems shall be designed and installed in accordance with NFPA 13, Standard for the Installation of Sprinkler Systems.	11.4.4.2	Conform
CP COL 9.5(1)	Waterflow alarms shall be provided and located so as to be monitored at a constantly attended location as determined by the individual responsible for fire protection.	11.4.4.3	Conform
CP COL 9.5(1)	Air-supported structures shall be used only for the storage of noncombustibles.	11.4.4.4	Conform
CP COL 9.5(1)	Temporary enclosures, including trailers, inside permanent plant buildings shall be prohibited except where permitted by the individual responsible for fire prevention and fire protection.	11.4.5	Conform

**Comanche Peak Nuclear Power Plant, Units 3 & 4
COL Application
Part 2, FSAR**

**Table 9.5.1-2R (Sheet 67 of 70)
CPNPP Units 3 & 4 Fire Protection Program Conformance with NFPA 804**

Standard Requirement	Paragraph	Conformance	Remarks
CP COL 9.5(1)	Where the floor area of a combustible enclosure exceeds 100 ft ² (9.29 m ²) or where the occupancy presents a fire exposure, the enclosure shall be protected with an approved automatic fire suppression system.	11.4.6	Conform
CP COL 9.5(1)	Storage of construction materials, equipment, or supplies that are either combustible or in combustible packaging shall be prohibited in main plant buildings unless either of the following conditions exists: (1) An approved automatic fire suppression system is in service in the storage area. (2) Loss of the materials or loss to the surrounding plant area would be minimal, as determined by the individual responsible for fire prevention and fire protection.	11.4.7	Conform
CP COL 9.5(1)	Construction areas that comprise mobile buildings arranged with the buildings adjoining each other to form one large fire area shall be avoided.	11.4.8	Conform
CP COL 9.5(1)	If buildings cannot be separated, fire walls shall be installed between	11.4.9	Conform
	units or automatic sprinklers shall be provided throughout the buildings.		
CP COL 9.5(1)	Fire alarms shall be connected to a constantly attended central location.	11.4.10	Conform
CP COL 9.5(1)	The handling, storage, and dispensing of flammable liquids and gases shall meet the requirements of NFPA 30, Flammable and Combustible Liquids Code, and NFPA 58, Liquefied Petroleum Gas Code.	11.4.11	Conform
CP COL 9.5(1)	Vehicle repair facilities shall meet the requirements of NFPA 30A, Code for Motor Fuel Dispensing Facilities and Repair Garages.	11.4.12	Conform
CP COL 9.5(1)	Fire hydrant systems with an approved water supply shall be provided in lay-down areas where the need is determined by the individual responsible for fire prevention and fire protection.	11.5.1	Conform

**Comanche Peak Nuclear Power Plant, Units 3 & 4
COL Application
Part 2, FSAR**

**Table 9.5.1-2R (Sheet 68 of 70)
CPNPP Units 3 & 4 Fire Protection Program Conformance with NFPA 804**

Standard Requirement	Paragraph	Conformance	Remarks
CP COL 9.5(1)	Combustible materials shall be separated by a clear space to allow access for manual fire-fighting equipment.	11.5.2	Conform
CP COL 9.5(1)	Access shall be provided and maintained to all fire-fighting equipment, including fire hoses, extinguishers, and hydrants.	11.5.3	Conform
CP COL 9.5(1)	Noncombustible or fire-retardant scaffolds, formwork, decking, and partitions shall be used both inside and outside permanent buildings where a fire could cause substantial damage or delay construction schedules.	11.6.1	Conform
CP COL 9.5(1)	The use of listed pressure-impregnated fire-retardant lumber or listed fire-retardant coatings shall be provided.	11.6.2	Conform
CP COL 9.5(1)	Tarpaulins (fabrics) and plastic films shall be certified to conform to the weather-resistant and fire-retardant materials described in	11.6.3	Conform
NFPA 701, Standard Methods of Fire Tests for Flame Propagation of Textiles and Films.			
CP COL 9.5(1)	Where it is necessary to store new nuclear fuel in areas other than the permanent storage facilities, a written procedure shall be developed to address separation from the following: (1) Combustible materials. (2) Security. (3) Nuclear criticality. (4) Packing material. (5) Noncombustible or limited-combustible building materials. (6) Standpipe. (7) Portable fire extinguishers. (8) Hydrant protection.	11.6.4	Conform
CP COL 9.5(1)	The permanent underground yard system, fire hydrants, and water supply (at least one water source), as indicated in Chapter 10, shall be installed during the early stages of construction.	11.7.1	Conform
CP COL 9.5(1)	Where provision of all or part of the permanent underground system and water supply is not practical, temporary systems shall be provided.	11.7.1.1	Conform

**Comanche Peak Nuclear Power Plant, Units 3 & 4
COL Application
Part 2, FSAR**

**Table 9.5.1-2R (Sheet 69 of 70)
CPNPP Units 3 & 4 Fire Protection Program Conformance with NFPA 804**

Standard Requirement	Paragraph	Conformance	Remarks	
CP COL 9.5(1)	Temporary water supplies shall be hydrostatically tested, flushed, and arranged to maintain a high degree of reliability, including protection from freezing and loss of power.	11.7.1.2	Conform	
CP COL 9.5(1)	Hydrants shall be installed as specified in 11.7.2.1 and 11.7.2.2.	11.7.2	Conform	
CP COL 9.5(1)	Hydrants shall be installed in the vicinity of main plant buildings, important warehouses, office or storage trailer complexes, and outside structures with combustible construction or combustible concrete formwork (e.g., cooling towers).	11.7.2.1	Conform	
CP COL 9.5(1)	The underground main shall be arranged to minimize the possibility that any one break will remove from service any fixed water extinguishing system or leave any area without accessible hydrant protection.	11.7.2.2	Conform	See Subsection 9.5.1.6.
CP COL 9.5(1)	A fire protection water supply shall be provided on the construction site and shall be capable of furnishing the larger of the following for a minimum 2-hour duration: (1) 500 gpm (1892.5 L/min). (2) The in-service fixed water extinguishing system with the highest water demand and 500 gpm (1892.5 L/min) for hose streams.	11.7.3	Conform	
CP COL 9.5(1)	The highest water demand shall be determined by the hazards present at the stage of construction, which might not correspond with the highest water demand of the completed plant.	11.7.3.1	Conform	
CP COL 9.5(1)	As fixed water extinguishing systems are completed, they shall be placed in service, even when the available construction phase fire protection water supply is not able to meet the designed system demand, and the following criteria shall be met: (1) When the permanent hazard is introduced, the water supply shall be capable of providing the designed system demand. (2) Where construction water is used in permanent systems, adequate strainers shall be provided to prevent clogging of the system by foreign objects and dirt.	11.7.3.2	Conform	

**Comanche Peak Nuclear Power Plant, Units 3 & 4
COL Application
Part 2, FSAR**

**Table 9.5.1-2R (Sheet 70 of 70)
CPNPP Units 3 & 4 Fire Protection Program Conformance with NFPA 804**

Standard Requirement	Paragraph	Conformance	Remarks
CP COL 9.5(1)	The water supply shall provide the required pressure for hose connections at the highest elevation.	11.7.3.3	Conform
CP COL 9.5(1)	Fire-fighting equipment shall be provided in accordance with NFPA 600, Standard on Industrial Fire Brigades, and NFPA 241, Standard for Safeguarding Construction, Alteration, and Demolition Operations.	11.8.1	Conform
CP COL 9.5(1)	Portable fire extinguishers of the required capacity shall be provided in accordance with NFPA 10, Standard for Portable Fire Extinguishers, where one or more of the following conditions exist: (1) Flammable liquids are stored or handled. (2) Combustible materials are stored. (3) Temporary oil- or gas-fired equipment is used. (4) A tar or asphalt kettle is used. (5) Welding or open flames are in use.	11.8.2	Conform
CP COL 9.5(1)	A standpipe system shall be provided in any permanent building that has walls erected that are equivalent to two floors in height.	11.8.3	Conform
CP COL 9.5(1)	Additional standpipe hose connections shall be added to each floor level as soon as sufficient landings are available to fight fires from that level.	11.8.3.1	Conform
CP COL 9.5(1)	Protection from freezing shall be provided.	11.8.3.2	Conform
CP COL 9.5(1)	Hoses and nozzles shall be available at strategic locations, such as inside hose cabinets or hose houses or on dedicated fire response vehicles.	11.8.4	Conform
CP COL 9.5(1)	If fire hose connections are not compatible with local fire-fighting equipment, adapters shall be made available.	11.8.5	Conform

Comanche Peak Nuclear Power Plant, Units 3 & 4
 COL Application
 Part 2, FSAR

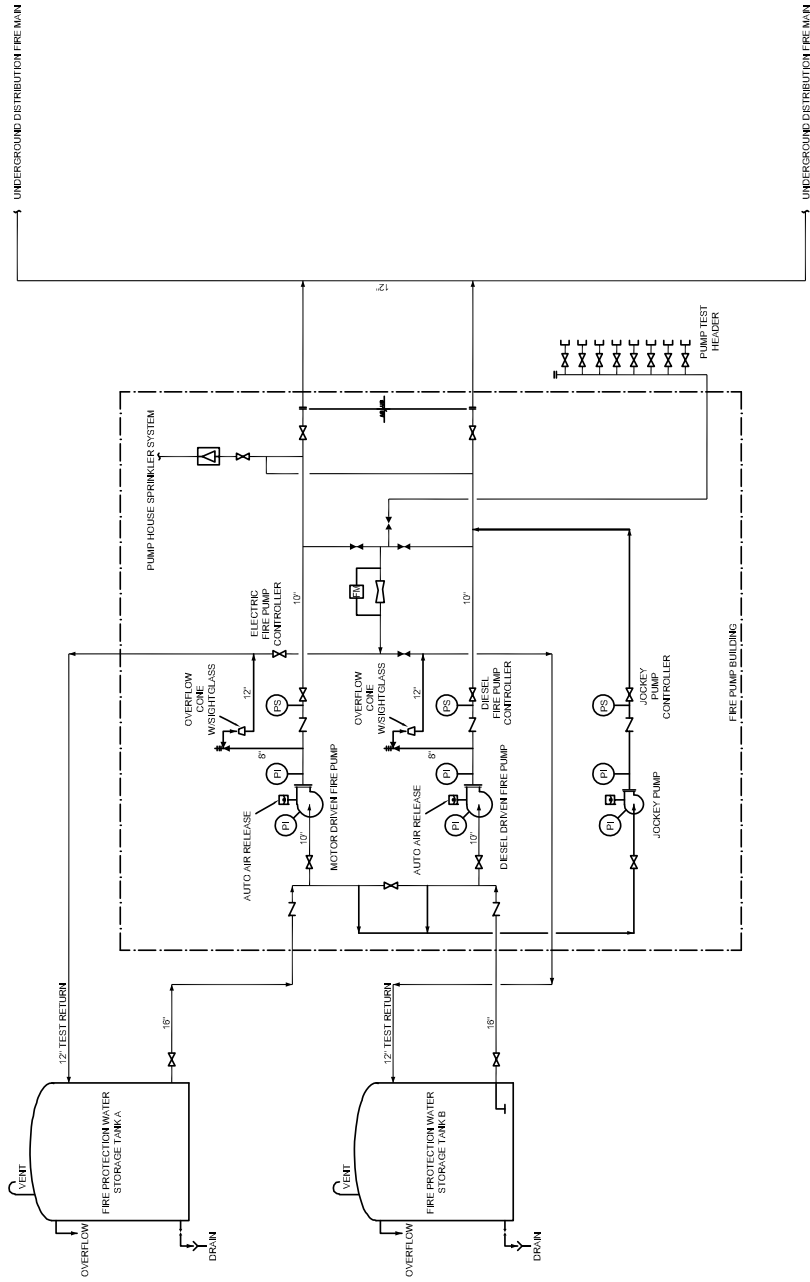

CP COL 9.5(2)

Figure 9.5.1-201 Fire Protection Water Supply System

**Comanche Peak Nuclear Power Plant, Units 3 & 4
COL Application
Part 2, FSAR**

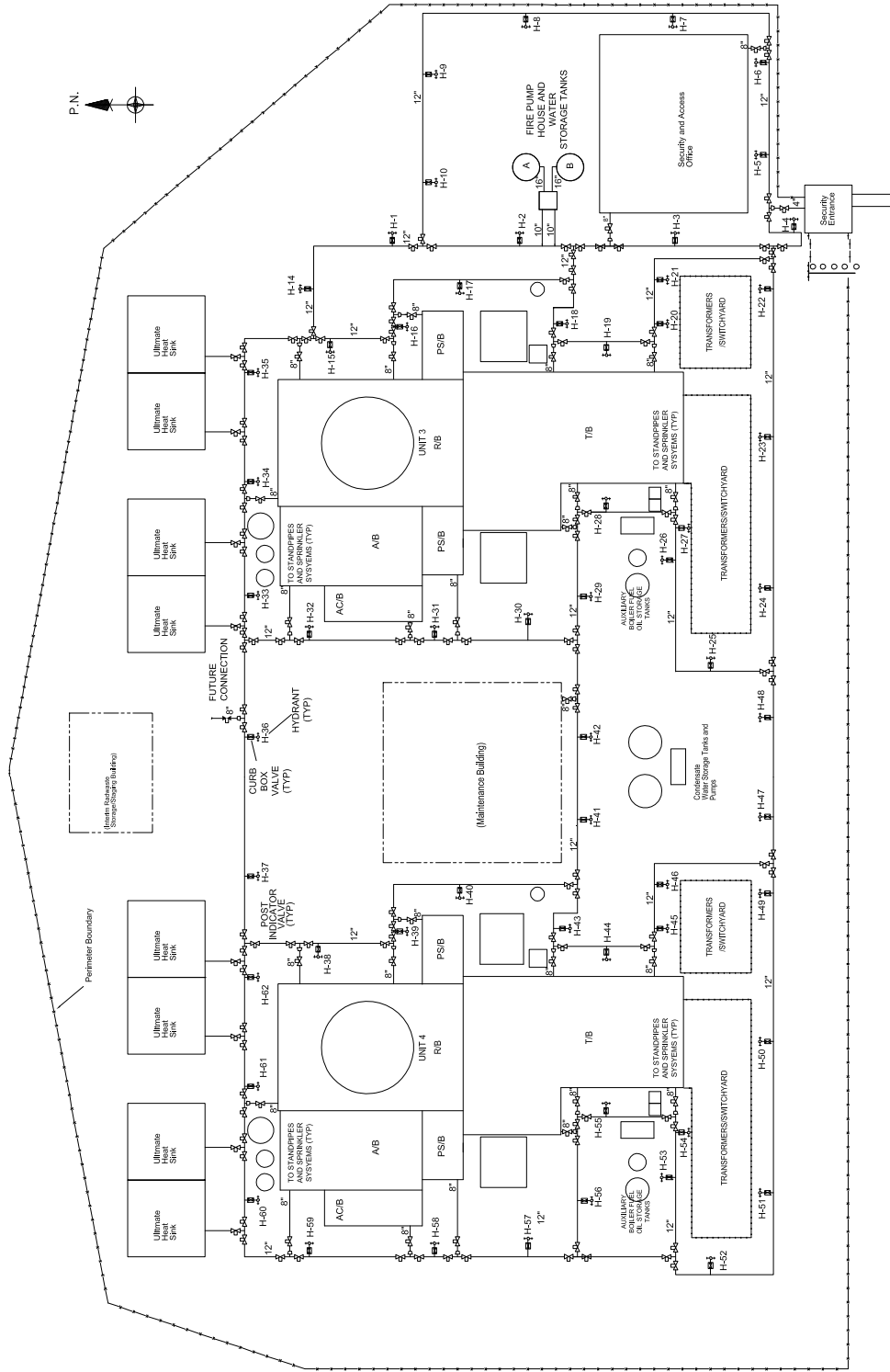

Figure 9.5.1-202 CPNPP Units 3 & 4 Fire Main System

CP COL 9.5(2)

**Comanche Peak Nuclear Power Plant, Units 3 & 4
COL Application
Part 2, FSAR**

**APPENDIX 9A
FIRE HAZARD ANALYSIS**

**Comanche Peak Nuclear Power Plant, Units 3 & 4
COL Application
Part 2, FSAR**

TABLE OF CONTENTS

<u>Section</u>	<u>Title</u>	<u>Page</u>
9A.1	Introduction	9A-1
9A.3	Fire Hazard Analysis Results	9A-1
9A.3.101	FA7-201 A-ESW Pump Room	9A-2
9A.3.102	FA7-202 A-UHS Transfer Pump Room	9A-3
9A.3.103	FA7-203 A-UHS	9A-4
9A.3.104	FA7-204 B-ESW Pump Room	9A-5
9A.3.105	FA7-205 B-UHS Transfer Pump Room	9A-6
9A.3.106	FA7-206 B-UHS	9A-7
9A.3.107	FA7-207 C-ESW Pump Room	9A-8
9A.3.108	FA7-208 C-UHS Transfer Pump Room	9A-9
9A.3.109	FA7-209 C-UHS	9A-11
9A.3.110	FA7-210 D-ESW Pump Room	9A-12
9A.3.111	FA7-211 D-UHS Transfer Pump Room	9A-13
9A.3.112	FA7-212 D-UHS	9A-14
9A.3.113	FA7-301 Transformer Yard	9A-15
9A.3.114	Miscellaneous Plant Support Structures	9A-16

**Comanche Peak Nuclear Power Plant, Units 3 & 4
COL Application
Part 2, FSAR**

LIST OF TABLES

<u>Number</u>	<u>Title</u>
9A-201	Fire Areas and Fire Zones
9A-202	Fire Hazard Analysis Summary
9A-203	Fire Zone/Fire Area Interfaces

**Comanche Peak Nuclear Power Plant, Units 3 & 4
COL Application
Part 2, FSAR**

LIST OF FIGURES

<u>Number</u>	<u>Title</u>
9A-201	Fire Zones and Fire Areas ESW Pump Rooms and UHS
9A-202	Fire Zones and Fire Areas Transformer Yard

**Comanche Peak Nuclear Power Plant, Units 3 & 4
COL Application
Part 2, FSAR**

APPENDIX 9A FIRE HAZARD ANALYSIS

This section of the referenced DCD is incorporated by reference with the following departures and/or supplements.

9A.1 INTRODUCTION

CP COL 9.5(2) Add the following information after the first paragraph in **DCD Subsection 9A.1**.

This fire hazard analysis (FHA) is performed on the basis of one unit. The fire zones and arrangement of CPNPP Units 3 and 4 are identical. When unit specificity is required, the fire area and fire zone designation is prefixed with a “3” or “4” numeral. For example, Fire Zone “FA1-101-01” within the FHA is designated as “3-FA1-101-01” for Unit 3, and as “4-FA1-101-01” for Unit 4.

9A.3 FIRE HAZARD ANALYSIS RESULTS

CP COL 9.5(2) Add the following information after second paragraph in **DCD Subsection 9A.3**.

The FHA is also conducted for the following site-specific plant structures and associated fire area and/or fire zones which are depicted in **Figures 9A-201** and **9A-202**.

- Essential Service Water (ESW) Pumping Station
- Ultimate Heat Sink (UHS)
- Transformer Yard
- Plant Support Buildings

Plant buildings are located such that unacceptable exposure to environmental impact such as wildfires does not occur. Structures are located such that non-safety related structures do not pose unacceptable exposure to safety-related structures. For a fire zone by fire zone review, **Table 9A-202** identifies the type and quantity of combustible materials in each fire zone of the site-specific plant structures and provides a summary of the FHA for the associated fire zone. The discussion below reviews the fire hazards for each fire area on an area by area basis. **Table 9A-203** shows the fire zone to fire zone interface which also depicts fire area to fire area boundaries that must be protected for 3-hour fire rated boundaries.

CP COL 9.5(2) Add the following new subsections after **DCD Subsection 9A.3.100**.

Comanche Peak Nuclear Power Plant, Units 3 & 4
COL Application
Part 2, FSAR

9A.3.101 FA7-201 A-ESW Pump Room

The A-ESW pump room is shown on [Figure 9A-201](#). The room contains the train A ESW pump, circuits, and controls. The walls of this room are of reinforced concrete construction which easily provides a fire resistive capability exceed 3-hour fire resistance as defined by ASTM E-119. The door and all openings or penetrations into this room are protected with 3-hour fire resistive seals or components. The combustible material associated with the ESW pump installation is lube oil and electrical cables.

Fire Detection and Suppression Features

The room is provided with automatic fire detection and automatic wet-pipe sprinkler fire suppression in accordance with RG 1.189 Positions 3.1.1.k and 6.1.9. This will assure that any fire damage occurring within this room is minimized and does not compromise adjacent fire zones and safety-related equipment.

Smoke Control Features

The room's HVAC exhaust will normally ventilate any smoke generated within the room. The plant fire brigade using portable fans and flexible ducting can supplement smoke removal capability.

Fire Protection Adequacy Evaluation

A fire is not expected to occur within this area due to the limited ignition sources and low combustible fire loading. Should a fire occur, it would not propagate outside the fire area boundaries.

Fire Protection System Integrity

The wet-pipe sprinkler system and standpipe is seismically supported such that the failure of the system piping during a design basis seismic event will not damage any of the safety-related equipment in the room. The fire suppression system is designed to NFPA codes and standards, using approved material. The fire suppression system is installed under a QA program that ensures system integrity.

Safe Shutdown Evaluation

The electrical circuits located within this area are associated with the safety train A ESW system. The electrical circuits from other safety trains in this area will be protected by a one-hour fire rated wrap. As such, a fire in this area could only adversely impact the safety train A safe-shutdown functions. The fire would be confined to this area, by fire rated barriers and/or by physical separation. Therefore, equipment within safety trains B, C, and D would remain free of fire damage and able to obtain and maintain safe-shutdown.

Radioactive Release to Environment Evaluation

Comanche Peak Nuclear Power Plant, Units 3 & 4
COL Application
Part 2, FSAR

The ESW pump room is a non-radiological area with no piping system containing radioactive material and no other radioactive material located within the area. As such, any fire that could occur within the pump room is not deemed capable of producing a radioactive release.

9A.3.102 FA7-202 A-UHS Transfer Pump Room

The A-UHS transfer pump room is shown on [Figure 9A-201](#). The room contains an UHS transfer pump capable of transferring water from the A-cooling tower basin. Its circuits and controls are powered by either the D Class 1E bus. The walls of this room are of reinforced concrete construction which easily provides a fire resistive capability exceed 3-hour fire resistance as defined by ASTM E-119. The door and all openings or penetrations into this room are protected with 3-hour fire resistive seals or components. The combustible material associated with the UHS transfer pump installation is lube oil and electrical cables.

Fire Detection and Suppression Features

The room is provided with automatic fire detection and automatic wet-pipe sprinkler fire suppression in accordance with RG 1.189 Positions 3.1.1.k and 6.1.9. This will assure that any fire damage occurring within this room is minimized in damage and does not compromise adjacent fire zones and safety-related equipment.

Smoke Control Features

The room's HVAC exhaust will normally ventilate any smoke generated within the room. The plant fire brigade using portable fans and flexible ducting can supplement smoke removal capability.

Fire Protection Adequacy Evaluation

A fire is not expected to occur within this area due to the limited ignition sources and low combustible fire loading. Should a fire occur, it would not propagate outside the fire area boundaries.

Fire Protection System Integrity

The wet-pipe sprinkler system and standpipe is seismically supported such that the failure of the system piping during a design basis seismic event will not damage any of the safety-related equipment in the room. The fire suppression system is designed to NFPA codes and standards, using approved material. The fire suppression system is installed under a QA program that ensures system integrity.

Safe Shutdown Evaluation

The electrical circuits located within this area are associated with the safety train C or D depending on the manual breaker alignment. The transfer pump circuits are protected from a fire in the adjacent ESW pump room to assure the transfer

Comanche Peak Nuclear Power Plant, Units 3 & 4
COL Application
Part 2, FSAR

pump can perform its safe-shutdown function for a fire in the train A ESW pump room. As such, a fire in this area could only adversely impact the transfer pump functions from the A-cooling tower basin. The fire would be confined to this area by the 3-hour fire rated walls. Therefore, equipment within safety trains A, B, C, or D would remain free of fire damage and able to obtain and maintain safe-shutdown.

Radioactive Release to Environment Evaluation

The UHS transfer pump room is a non-radiological area with no piping system containing radioactive material and no other radioactive material located within the area. As such, any fire that could occur within the pump room is not deemed capable of producing a radioactive release.

9A.3.103 FA7-203 A-UHS

The A-UHS is shown on [Figure 9A-201](#). A-UHS is a two-fan unit non-combustible constructed cooling tower that serves as the environmental heat sink for safety-related cooling loads served by safety train A ESW system. The unit has two redundant air circulating fans and is constructed chiefly of reinforced concrete.

Fire Detection and Suppression Features

The principal fire protection feature of the UHS cooling tower safety train A is that it is constructed on non-combustible construction. A-UHS is fully separated from the adjacent B-UHS by a 3-hour fire rated wall of reinforced concrete. Since the combustible materials associated with the cooling tower structure are minimal and a fire would be confined to this specific safety train, no automatic fire detection or suppression feature are provided.

Smoke Control Features

The cooling tower structure is an outside component and any smoke from a fire such as associated with a fan motor would be freely released to the surrounding plant environment and not constitute an impediment to fire brigade response.

Fire Protection Adequacy Evaluation

Based on the minimal combustible material and the confinement of any fire that could occur to the location of occurrence, fire protection provided by the noncombustible construction is deemed adequate.

Fire Protection System Integrity

Fire protection of the cooling tower is inherent in its non-combustible design. Therefore, the cooling tower structure does not require automatic or manual fire suppression systems. The fire protection system integrity for this area is assured by the significant fire protection provided by the cooling tower's concrete structure, which provides fire separation.

Comanche Peak Nuclear Power Plant, Units 3 & 4
COL Application
Part 2, FSAR

Safe Shutdown Evaluation

The electrical circuits located within this area are associated with the safety train A ESW system and the associated ESW cooling for the train A CCW safe-shutdown cooling functions. As such, a fire in this area could adversely impact safety train A safe-shutdown functions. Since the fire would be confined to this area, equipment within safety trains B, C, and D would remain free of fire damage and able to obtain safe-shutdown.

Radioactive Release to Environment Evaluation

The A-UHS is a non-radiological area with no piping system containing radioactive material and no other radioactive material located within the area. As such, any fire that could occur within the cooling tower structure is not deemed capable of producing a radioactive release.

9A.3.104 FA7-204 B-ESW Pump Room

The B-ESW pump room is shown on [Figure 9A-201](#). The room contains the train B ESW pump, circuits, and controls. The walls of this room are of reinforced concrete construction which easily provides a fire resistive capability exceed 3-hour fire resistance as defined by ASTM E-119. The door and all openings or penetrations into this room are protected with 3-hour fire resistive seals or components. The combustible material associated with the ESW pump installation is lube oil and electrical cables.

Fire Detection and Suppression Features

The room is provided with automatic fire detection and automatic wet-pipe sprinkler fire suppression in accordance with RG 1.189 Positions 3.1.1.k and 6.1.9. This will assure that any fire damage occurring within this room is minimized and does not compromise adjacent fire zones and safety-related equipment.

Smoke Control Features

The room's HVAC exhaust will normally ventilate any smoke generated within the room. The plant fire brigade using portable fans and flexible ducting can supplement smoke removal capability.

Fire Protection Adequacy Evaluation

A fire is not expected to occur within this area due to the limited ignition sources and low combustible fire loading. Should a fire occur, it would not propagate outside the fire area boundaries.

Fire Protection System Integrity

The wet-pipe sprinkler system and standpipe is seismically supported such that the failure of the system piping during a design basis seismic event will not

Comanche Peak Nuclear Power Plant, Units 3 & 4
COL Application
Part 2, FSAR

damage any of the safety-related equipment in the room. The fire suppression system is designed to NFPA codes and standards, using approved material. The fire suppression system is installed under a QA program that ensures system integrity.

Safe Shutdown Evaluation

The electrical circuits located within this area are associated with the safety train B ESW system. The electrical circuits from other safety trains in this area will be protected by a one-hour fire rated wrap. As such, a fire in this area could only adversely impact safety train B safe-shutdown functions. The fire would be confined to this area, by fire rated barriers and/or by physical separation. Therefore, equipment within safety trains A, C and D would remain free of fire damage and able to obtain and maintain safe-shutdown.

Radioactive Release to Environment Evaluation

The ESW pump room is a non-radiological area with no piping system containing radioactive material and no other radioactive material located within the area. As such, any fire that could occur within the pump room is not deemed capable of producing a radioactive release.

9A.3.105 FA7-205 B-UHS Transfer Pump Room

The B-UHS transfer pump room is shown on [Figure 9A-201](#). The room contains an UHS transfer pump capable of transferring water from the B-cooling tower basin. Its circuits and controls are powered by either the D Class 1E bus. The walls of this room are of reinforced concrete construction which easily provides a fire resistive capability exceed 3-hour fire resistance as defined by ASTM E-119. The door and all openings or penetrations into this room are protected with 3-hour fire resistive seals or components. The combustible material associated with the UHS transfer pump installation is lube oil and electrical cables.

Fire Detection and Suppression Features

The room is provided with automatic fire detection and automatic wet-pipe sprinkler fire suppression in accordance with RG 1.189 Positions 3.1.1.k and 6.1.9. This will assure that any fire damage occurring within this room is minimized and does not compromise adjacent fire zones and safety-related equipment.

Smoke Control Features

The room's HVAC exhaust will normally ventilate any smoke generated within the room. The plant fire brigade using portable fans and flexible ducting can supplement smoke removal capability.

Fire Protection Adequacy Evaluation

Comanche Peak Nuclear Power Plant, Units 3 & 4
COL Application
Part 2, FSAR

A fire is not expected to occur within this area due to the limited ignition sources and low combustible fire loading. Should a fire occur, it would not propagate outside the fire area boundaries.

Fire Protection System Integrity

The wet-pipe sprinkler system and standpipe is seismically supported such that the failure of the system piping during a design basis seismic event will not damage any of the safety-related equipment in the room. The fire suppression system is designed to NFPA codes and standards, using approved material. The fire suppression system is installed under a QA program that ensures system integrity.

Safe Shutdown Evaluation

The electrical circuits located within this area are associated with the safety train C or D depending on the manual breaker alignment. The transfer pump circuits are protected from a fire in the adjacent ESW pump room to assure the transfer pump can perform its safe-shutdown function for a fire in the train B ESW pump room. As such, a fire in this area could only adversely impact the transfer pump functions from the B-cooling tower basin. The fire would be confined to this area by the 3-hour fire rated walls. Therefore, equipment within safety trains A, B, C, or D would remain free of fire damage and able to obtain and maintain safe-shutdown.

Radioactive Release to Environment Evaluation

The UHS transfer pump room is a non-radiological area with no piping system containing radioactive material and no other radioactive material located within the area. As such, any fire that could occur within the pump room is not deemed capable of producing a radioactive release.

9A.3.106 FA7-206 B-UHS

The B-UHS is shown on [Figure 9A-201](#). B-UHS is a two-fan unit non-combustible constructed cooling tower that serves as the environmental heat sink for safety-related cooling loads served by safety train B ESW system. The unit has two redundant air circulating fans and is constructed chiefly of reinforced concrete.

Fire Detection and Suppression Features

The principal fire protection feature of the UHS cooling tower safety train B is that it is constructed on non-combustible construction. B-UHS is fully separated from the adjacent A-UHS by a 3-hour fire rated wall of reinforced concrete. Since the combustible materials associated with the cooling tower structure are minimal and a fire would be confined to this specific safety train, no automatic fire detection or suppression feature are provided.

Smoke Control Features

Comanche Peak Nuclear Power Plant, Units 3 & 4
COL Application
Part 2, FSAR

The cooling tower structure is an outside component and any smoke from a fire such as associated with a fan motor would be freely released to the surrounding plant environment and not constitute an impediment to fire brigade response.

Fire Protection Adequacy Evaluation

Based on the minimal combustible material and the confinement of any fire that could occur to the location of occurrence, fire protection provided by the noncombustible construction is deemed adequate.

Fire Protection System Integrity

Fire protection of the cooling tower is inherent in its non-combustible design. Therefore, the cooling tower structure does not require automatic or manual fire suppression systems. The fire protection system integrity for this area is assured by the significant fire protection provided by the cooling tower's concrete structure, which provides fire separation.

Safe Shutdown Evaluation

The electrical circuits located within this area are associated with the safety train B ESW system and the associated ESW cooling for the train B CCW safe-shutdown cooling functions. As such, a fire in this area could adversely impact safety train B safe-shutdown functions. Since the fire would be confined to this area, equipment within safety trains A, C, and D would remain free of fire damage and able to obtain safe-shutdown.

Radioactive Release to Environment Evaluation

The B-UHS is a non-radiological area with no piping system containing radioactive material and no other radioactive material located within the area. As such, any fire that could occur within the cooling tower structure is not deemed capable of producing a radioactive release.

9A.3.107 FA7-207 C-ESW Pump Room

The C-ESW pump room is shown on [Figure 9A-201](#). The room contains the train C ESW pump, circuits, and controls. The walls of this room are of reinforced concrete construction which easily provides a fire resistive capability exceed 3-hour fire resistance as defined by ASTM E-119. The door and all openings or penetrations into this room are protected with 3-hour fire resistive seals or components. The combustible material associated with the ESW pump installation is lube oil and electrical cables.

Fire Detection and Suppression Features

The room is provided with automatic fire detection and automatic wet-pipe sprinkler fire suppression in accordance with RG 1.189 Positions 3.1.1.k and 6.1.9. This will assure that any fire damage occurring within this room is

Comanche Peak Nuclear Power Plant, Units 3 & 4
COL Application
Part 2, FSAR

minimized and does not compromise adjacent fire zones and safety-related equipment.

Smoke Control Features

The room's HVAC exhaust will normally ventilate any smoke generated within the room. The plant fire brigade using portable fans and flexible ducting can supplement smoke removal capability.

Fire Protection Adequacy Evaluation

A fire is not expected to occur within this area due to the limited ignition sources and low combustible fire loading. Should a fire occur, it would not propagate outside the fire area boundaries.

Fire Protection System Integrity

The wet-pipe sprinkler system and standpipe is seismically supported such that the failure of the system piping during a design basis seismic event will not damage any of the safety-related equipment in the room. The fire suppression system is designed to NFPA codes and standards, using approved material. The fire suppression system is installed under a QA program that ensures system integrity.

Safe Shutdown Evaluation

The electrical circuits located within this area are associated with the safety train C-ESW system. The electrical circuits from other safety trains in this area will be protected by a one-hour fire rated wrap. As such, a fire in this area could only adversely impact the safety train C safe-shutdown functions. The fire would be confined to this area, by fire rated barriers and/or by physical separation. Therefore, equipment within safety trains A, B, and D would remain free of fire damage and able to obtain and maintain safe-shutdown.

Radioactive Release to Environment Evaluation

The ESW pump room is a non-radiological area with no piping system containing radioactive material and no other radioactive material located within the area. As such, any fire that could occur within the pump room is not deemed capable of producing a radioactive release.

9A.3.108 FA7-208 C-UHS Transfer Pump Room

The C-UHS transfer pump room is shown on [Figure 9A-201](#). The room contains an UHS transfer pump capable of transferring water from the C-cooling tower basin. Its circuits and controls are powered by either the A Class 1E bus. The walls of this room are of reinforced concrete construction which easily provides a fire resistive capability exceed 3-hour fire resistance as defined by ASTM E-119. The door and all openings or penetrations into this room are protected with 3-

Comanche Peak Nuclear Power Plant, Units 3 & 4
COL Application
Part 2, FSAR

hour fire resistive seals or components. The combustible material associated with the UHS transfer pump installation is lube oil and electrical cables.

Fire Detection and Suppression Features

The room is provided with automatic fire detection and automatic wet-pipe sprinkler fire suppression in accordance with RG 1.189 Positions 3.1.1.k and 6.1.9. This will assure that any fire damage occurring within this room is minimized in damage and does not compromise adjacent fire zones and safety-related equipment.

Smoke Control Features

The room's HVAC exhaust will normally ventilate any smoke generated within the room. The plant fire brigade using portable fans and flexible ducting can supplement smoke removal capability.

Fire Protection Adequacy Evaluation

A fire is not expected to occur within this area due to the limited ignition sources and low combustible fire loading. Should a fire occur, it would not propagate outside the fire area boundaries.

Fire Protection System Integrity

The wet-pipe sprinkler system and standpipe is seismically supported such that the failure of the system piping during a design basis seismic event will not damage any of the safety-related equipment in the room. The fire suppression system is designed to NFPA codes and standards, using approved material. The fire suppression system is installed under a QA program that ensures system integrity.

Safe Shutdown Evaluation

The electrical circuits located within this area are associated with the safety train A or B depending on the manual breaker alignment. The transfer pump circuits are protected from a fire in the adjacent ESW pump room to assure the transfer pump can perform its safe-shutdown function for a fire in the train C ESW pump room. As such, a fire in this area could only adversely impact the transfer pump functions from the C-cooling tower basin. The fire would be confined to this area by the 3-hour fire rated walls. Therefore, equipment within safety trains C, D, A, or B would remain free of fire damage and able to obtain and maintain safe-shutdown.

Radioactive Release to Environment Evaluation

The UHS transfer pump room is a non-radiological area with no piping system containing radioactive material and no other radioactive material located within the area. As such, any fire that could occur within the pump room is not deemed capable of producing a radioactive release.

Comanche Peak Nuclear Power Plant, Units 3 & 4
COL Application
Part 2, FSAR

9A.3.109 FA7-209 C-UHS

The C-UHS is shown on [Figure 9A-201](#). C-UHS is a two-fan unit non-combustible constructed cooling tower that serves as the environmental heat sink for safety-related cooling loads served by safety train C ESW system. The unit has two redundant air circulating fans and is constructed chiefly of reinforced concrete.

Fire Detection and Suppression Features

The principal fire protection feature of the UHS cooling tower safety train C is that it is constructed on non-combustible construction. C-UHS is fully separated from the adjacent D-UHS by a 3-hour fire rated wall of reinforced concrete. Since the combustible materials associated with the cooling tower structure are minimal and a fire would be confined to this specific safety train, no automatic fire detection or suppression feature are provided.

Smoke Control Features

The cooling tower structure is an outside component and any smoke from a fire such as associated with a fan motor would be freely released to the surrounding plant environment and not constitute an impediment to fire brigade response.

Fire Protection Adequacy Evaluation

Based on the minimal combustible material and the confinement of any fire that could occur to the location of occurrence, fire protection provided by the noncombustible construction is deemed adequate.

Fire Protection System Integrity

Fire protection of the cooling tower is inherent in its non-combustible design. Therefore, the cooling tower structure does not require automatic or manual fire suppression systems. The fire protection system integrity for this area is assured by the significant fire protection provided by the cooling tower's concrete structure, which provides fire separation.

Safe Shutdown Evaluation

The electrical circuits located within this area are associated with the safety train C ESW system and the associated ESW cooling for the train C CCW safe-shutdown cooling functions. As such, a fire in this area could adversely impact safety train C safe-shutdown functions. Since the fire would be confined to this area, equipment within safety trains A, B, and D would remain free of fire damage and able to obtain safe-shutdown.

Radioactive Release to Environment Evaluation

The C-UHS is a non-radiological area with no piping system containing radioactive material and no other radioactive material located within the area. As

Comanche Peak Nuclear Power Plant, Units 3 & 4
COL Application
Part 2, FSAR

such, any fire that could occur within the cooling tower structure is not deemed capable of producing a radioactive release.

9A.3.110 FA7-210 D-ESW Pump Room

The D-ESW pump room is shown on [Figure 9A-201](#). The room contains the train D ESW pump, circuits, and controls. The walls of this room are of reinforced concrete construction which easily provides a fire resistive capability exceed 3-hour fire resistance as defined by ASTM E-119. The door and all openings or penetrations into this room are protected with 3-hour fire resistive seals or components. The combustible material associated with the ESW pump installation is lube oil and electrical cables.

Fire Detection and Suppression Features

The room is provided with automatic fire detection and automatic wet-pipe sprinkler fire suppression in accordance with RG 1.189 Positions 3.1.1.k and 6.1.9. This will assure that any fire damage occurring within this room is minimized and does not compromise adjacent fire zones and safety-related equipment.

Smoke Control Features

The room's HVAC exhaust will normally ventilate any smoke generated within the room. The plant fire brigade using portable fans and flexible ducting can supplement smoke removal capability.

Fire Protection Adequacy Evaluation

A fire is not expected to occur within this area due to the limited ignition sources and low combustible fire loading. Should a fire occur, it would not propagate outside the fire area boundaries.

Fire Protection System Integrity

The wet-pipe sprinkler system and standpipe is seismically supported such that the failure of the system piping during a design basis seismic event will not damage any of the safety-related equipment in the room. The fire suppression system is designed to NFPA codes and standards, using approved material. The fire suppression system is installed under a QA program that ensures system integrity.

Safe Shutdown Evaluation

The electrical circuits located within this area are associated with the safety train D ESW system. The electrical circuits from other safety trains in this area will be protected by a one-hour fire rated wrap. As such, a fire in this area could only adversely impact the safety train D safe-shutdown functions. The fire would be confined to this area, by fire rated barriers and/or by physical separation.

Comanche Peak Nuclear Power Plant, Units 3 & 4
COL Application
Part 2, FSAR

Therefore, equipment within safety trains A, B and C would remain free of fire damage and able to obtain and maintain safe-shutdown.

Radioactive Release to Environment Evaluation

The ESW pump room is a non-radiological area with no piping system containing radioactive material and no other radioactive material located within the area. As such, any fire that could occur within the pump room is not deemed capable of producing a radioactive release.

9A.3.111 FA7-211 D-UHS Transfer Pump Room

The D-UHS transfer pump room is shown on [Figure 9A-201](#). The room contains an UHS transfer pump capable of transferring water from the D-cooling tower basin. Its circuits and controls are powered by either the A Class 1E bus. The walls of this room are of reinforced concrete construction which easily provides a fire resistive capability exceed 3-hour fire resistance as defined by ASTM E-119. The door and all openings or penetrations into this room are protected with 3-hour fire resistive seals or components. The combustible material associated with the UHS transfer pump installation is lube oil and electrical cables.

Fire Detection and Suppression Features

The room is provided with automatic fire detection and automatic wet-pipe sprinkler fire suppression in accordance with RG 1.189 Positions 3.1.1.k and 6.1.9. This will assure that any fire damage occurring within this room is minimized in damage and does not compromise adjacent fire zones and safety-related equipment.

Smoke Control Features

The room's HVAC exhaust will normally ventilate any smoke generated within the room. The plant fire brigade using portable fans and flexible ducting can supplement smoke removal capability.

Fire Protection Adequacy Evaluation

A fire is not expected to occur within this area due to the limited ignition sources and low combustible fire loading. Should a fire occur, it would not propagate outside the fire area boundaries.

Fire Protection System Integrity

The wet-pipe sprinkler system and standpipe is seismically supported such that the failure of the system piping during a design basis seismic event will not damage any of the safety-related equipment in the room. The fire suppression system is designed to NFPA codes and standards, using approved material. The fire suppression system is installed under a QA program that ensures system integrity.

Comanche Peak Nuclear Power Plant, Units 3 & 4
COL Application
Part 2, FSAR

Safe Shutdown Evaluation

The electrical circuits located within this area are associated with the safety train A or B depending on the manual breaker alignment. The transfer pump circuits are protected from a fire in the adjacent ESW pump room to assure the transfer pump can perform its safe-shutdown function for a fire in the train D ESW pump room. As such, a fire in this area could only adversely impact the transfer pump functions from the D-cooling tower basin. Since the fire would be confined to this area by the 3-hour fire rated walls. Therefore, equipment within safety trains C, D, A, or B would remain free of fire damage and able to obtain and maintain safe-shutdown.

Radioactive Release to Environment Evaluation

The UHS transfer pump room is a non-radiological area with no piping system containing radioactive material and no other radioactive material located within the area. As such, any fire that could occur within the pump room is not deemed capable of producing a radioactive release.

9A.3.112 FA7-212 D-UHS

The D-UHS is shown on [Figure 9A-201](#). D-UHS is a two-fan unit non-combustible constructed cooling tower that serves as the environmental heat sink for safety-related cooling loads served by safety train D ESW system. The unit has two redundant air circulating fans and is constructed chiefly of reinforced concrete.

Fire Detection and Suppression Features

The principal fire protection feature of the UHS cooling tower safety train D is that it is constructed on non-combustible construction. D-UHS is fully separated from the adjacent C-UHS by a 3-hour fire rated wall of reinforced concrete. Since the combustible materials associated with the cooling tower structure are minimal and a fire would be confined to this specific safety train, no automatic fire detection or suppression feature are provided.

Smoke Control Features

The cooling tower structure is an outside component and any smoke from a fire such as associated with a fan motor would be freely released to the surrounding plant environment and not constitute an impediment to fire brigade response.

Fire Protection Adequacy Evaluation

Based on the minimal combustible material and the confinement of any fire that could occur to place of occurrence, fire protection provided by the non-combustible construction is deemed adequate.

Fire Protection System Integrity

Comanche Peak Nuclear Power Plant, Units 3 & 4
COL Application
Part 2, FSAR

Fire protection of the cooling tower is inherent in its non-combustible design. Therefore, the cooling tower structure does not require automatic or manual fire suppression systems. The fire protection system integrity for this area is assured by the significant fire protection provided by the cooling tower's concrete structure, which provides fire separation.

Safe Shutdown Evaluation

The electrical circuits located within this area are associated with the safety train D ESW system and the associated ESW cooling for the train D CCW safe-shutdown cooling functions. As such, a fire in this area could adversely impact safety train D safe-shutdown functions. Since the fire would be confined to this area, equipment within safety trains A, B, and C would remain free of fire damage and able to obtain safe-shutdown.

Radioactive Release to Environment Evaluation

The D-UHS is a non-radiological area with no piping system containing radioactive material and no other radioactive material located within the area. As such, any fire that could occur within the cooling tower structure is not deemed capable of producing a radioactive release.

9A.3.113 FA7-301 Transformer Yard

The transformer yard is shown in [Figure 9A-202](#). The area is located on the south end of each unit's turbine building. Due to the significant plant impact of a transformer fire, the transformer yard is designated as fire area FA7-301. The fire zones in FA7-301 are presented in [Table 9A-201](#).

The transformer yard is located closer than 50 ft. to the turbine building and the 345kV GIS Building for the RATs due to site space restrictions. To compensate for the close spacing, a freestanding 3-hour fire rated barrier separates the transformer yard from the turbine building. A one-hour fire rated barrier separates each transformer from any adjacent transformer. The separation features meet RG 1.189, NFPA 804, and nuclear property insurer's requirements.

Provision for drainage and oil spill containment is in accordance with NFPA 804, and IEEE 980.

Fire Detection and Suppression Features

Each transformer is provided with an automatic fire detection system (heat detectors) which alarms to the plant fire alarm system and actuates an automatic water spray system installed in accordance with NFPA 15 (Reference 9.5.1-22) requirements.

Smoke Control Features

The transformers are outside components and any smoke from a fire such as associated with a transformer fluid fire would be freely released to the

Comanche Peak Nuclear Power Plant, Units 3 & 4
COL Application
Part 2, FSAR

surrounding plant environment and not constitute an impediment to fire brigade response.

Fire Protection Adequacy Evaluation

The fire protection features installed for the transformer yard, fire walls, automatic fire detection and water spray systems, meet industry accepted practices, NFPA code guidance, NRC guidance, and nuclear plant property insurer's recommendations. On this basis, the fire protection features are considered adequate for the fire hazard present.

Fire Protection System Integrity

The firewalls for the transformer yard are freestanding walls designed for wind resistance and seismic occurrences. The fire protection systems are designed, installed, and tested in accordance with NFPA codes and standards under a nuclear quality assurance program. This assures a high degree of fire protection system integrity required for an operating nuclear power plant.

Safe Shutdown Evaluation

A fire involving one of the transformer yard's units would likely necessitate plant shutdown. The yard is located away from safety-related systems, components, and structures and would not spread to impact such features due to the firewalls, automatic fire detection and suppression systems provided. Since none of the four safety trains of equipment provided to assure plant shutdown would be affected, no adverse impact of safe-shutdown would result from a fire in the transformer yard.

Radioactive Release to Environment Evaluation

The transformer yard is a non-radiological area with no piping system containing radioactive material and no other radioactive material located within the area. As such, any fire that could occur within the transformer yard is not deemed capable of producing a radioactive release.

9A.3.114 Miscellaneous Plant Support Structures

The CPNPP Units 3 and 4 design features a number of miscellaneous plant support structures such as the office building, security structures, warehouse, fire pump house, makeup pumping station, circulating water system cooling towers, maintenance and storage building, auxiliary boiler building, etc. These structures do not contain any equipment that performs a safety-related function. The structures are located on the CPNPP Units 3 and 4 site such that they do not represent an unacceptable fire exposure to any safety-related structure, system, or component.

Fire Detection and Suppression Features

Comanche Peak Nuclear Power Plant, Units 3 & 4
COL Application
Part 2, FSAR

Fire detection and suppression system features vary for the miscellaneous plant support structures according to their importance to personnel safety, continued operation, and the influence of applicable NFPA codes and standards, building code requirements, and nuclear plant property insurer's requirements or recommendations.

Smoke Control Features

Smoke control features are provided for the miscellaneous plant support structures according to building code requirements and personnel safety concerns. Additional smoke removal in these structures can be provided by portable fans units and ducting by the plant fire brigade of standard firefighting practices.

Fire Protection Adequacy Evaluation

Based on the compliance with accepted industry practices, the fire protection features provided for the miscellaneous CPNPP Units 3 and 4 structures are deemed adequate for the fire hazards present.

Fire Protection System Integrity

Fire protection systems provided for the miscellaneous plant structures are designed, installed, tested, and maintained in accordance with applicable NFPA codes and standards. This assures a high degree of system integrity.

Safe Shutdown Evaluation

The miscellaneous CPNPP Units 3 and 4 structures do not contain any safety-related or safe-shutdown features. The structures are located such that they do not pose an unacceptable fire exposure to any safety-related or safe-shutdown structure, system, or component. As such, a fire in any of the miscellaneous CPNPP Units 3 and 4 support structure will not compromise the ability to obtain safe plant shutdown.

Radioactive Release to Environment Evaluation

The miscellaneous CPNPP Units 3 and 4 support structures are non-radiological areas with no piping system containing radioactive material and no other radioactive material located within the areas. As such, any fire that could occur within one of the site support structures is not deemed capable of producing a radioactive release."

Comanche Peak Nuclear Power Plant, Units 3 & 4
COL Application
Part 2, FSAR

CP COL 9.5(2)

Table 9A-201

Fire Areas and Fire Zones

Building	Train	Fire Area	Fire Area Designation	Fire Zone	Fire Zone Designation
O/B	A	FA7-201	A-ESW Pump Room	FA7-201-01	A-ESW Pump Room
O/B	D	FA7-202	A-UHS Transfer Pump Room	FA7-202-01	A-UHS Transfer Pump Room
O/B	A	FA7-203	A-UHS	FA7-203-01	A-UHS
O/B	B	FA7-204	B-ESW Pump Room	FA7-204-01	B-ESW Pump Room
O/B	D	FA7-205	B-UHS Transfer Pump Room	FA7-205-01	B-UHS Transfer Pump Room
O/B	B	FA7-206	B-UHS	FA7-206-01	B-UHS
O/B	C	FA7-207	C-ESW Pump Room	FA7-207-01	C-ESW Pump Room
O/B	A	FA7-208	C-UHS Transfer Pump Room	FA7-208-01	C-UHS Transfer Pump Room
O/B	C	FA7-209	C-UHS	FA7-209-01	C-UHS
O/B	D	FA7-210	D-ESW Pump Room	FA7-210-01	D-ESW Pump Room
O/B	A	FA7-211	D-UHS Transfer Pump Room	FA7-211-01	D-UHS Transfer Pump Room
O/B	D	FA7-212	D-UHS	FA7-212-01	D-UHS
O/B	N	FA7-301	Transformer Yard	FA7-301-01	Main Generator Excitation Transformer Zone
O/B	N	FA7-301	Transformer Yard	FA7-301-02	A-Unit Auxiliary Transformer Zone
O/B	N	FA7-301	Transformer Yard	FA7-301-03	B-Unit Auxiliary Transformer Zone
O/B	N	FA7-301	Transformer Yard	FA7-301-04	C-Unit Auxiliary Transformer Zone
O/B	N	FA7-301	Transformer Yard	FA7-301-05	Spare Unit Auxiliary Transformer Zone
O/B	N	FA7-301	Transformer Yard	FA7-301-06	Spare Main Transformer Zone
O/B	N	FA7-301	Transformer Yard	FA7-301-07	C-Main Transformer Zone
O/B	N	FA7-301	Transformer Yard	FA7-301-08	B-Main Transformer Zone
O/B	N	FA7-301	Transformer Yard	FA7-301-09	A-Main Transformer Zone
O/B	N	FA7-301	Transformer Yard	FA7-301-10	Reserve Auxiliary Transformer 1 Zone
O/B	N	FA7-301	Transformer Yard	FA7-301-11	Reserve Auxiliary Transformer 2 Zone
O/B	N	FA7-301	Transformer Yard	FA7-301-12	Reserve Auxiliary Transformer 4 Zone
O/B	N	FA7-301	Transformer Yard	FA7-301-13	Reserve Auxiliary Transformer 3 Zone

**Comanche Peak Nuclear Power Plant, Units 3 & 4
COL Application
Part 2, FSAR**

Table 9A-202 (Sheet 1 of 25)
Fire Hazard Analysis Summary

Fire Zone: **FA7-201-01**

Building:	ESW Pumping Station
Floor(s):	1

DCD Fig:	9A-201
DCD Sect:	9A.3.95

Area Designation:	A-ESW Pump Room
Zone Designation:	A-ESW Pump Room

Associated Safety Division(s) **A**

Applicable Regulatory and Code Ref(s):	IBC, RG 1.189; NFPA 10, 13, 14, 72 and 804
--	---

Wall	Floor	Ceiling
FA7-202-01 FA7-203-01 FA7-206-01	-	-

Adjacent Fire Zones:
(Primary Inter face
Listed See Table 9A-203
For Complete Listing)

Fire Barrier Description:
Walls of reinforced concrete or other material providing a minimum 3-hour fire resistance rating form the boundaries of this room. The door to the room is 3-hour fire rated and all openings and penetrations into the room are rated to provide 3-hour fire resistance.

Potential Combustibles	
Item	Heat Release (Btu)
Lube Oil	5.15E+05
Grease	1.84E+06
High Voltage Cable	2.46E+06
Low Voltage Cable	2.14E+06
Control Cable	3.09E+06
Instrumentation Cable	3.29E+06

Fire Detection – Primary	Fire Detection - Backup
Automatic Fire Detection System	Manual Fire Alarm Pull Station
Fire Suppression – Primary	Fire Suppression - Backup
Wet Pipe Sprinkler	Fire Hose Station

Fire Impact to Zone	
Suppression System Operates	Suppression System Fails to Op.
A quickly detected and suppressed fire in this room will minimize fire damage to the safety-related equipment consistent with GDC-3.	A fire in this fire zone could damage the few functions of 1 safe-shutdown train. Three trains remain free from the fire damage.

Floor Area (ft ²)	1650
-------------------------------	-------------

Fire Zone Combustible Summary	
	BTU/ft ²
Anticipated Combustible Loading:	8.1E+03
Maximum Anticipated Combustible Loading:	9.8E+03

**Comanche Peak Nuclear Power Plant, Units 3 & 4
COL Application
Part 2, FSAR**

Table 9A-202 (Sheet 2 of 25)
Fire Hazard Analysis Summary

Fire Zone: **FA7-202-01**

Building:	ESW Pumping Station
Floor(s):	1

Area Designation:	A-UHS Transfer Pump Room
Zone Designation:	A-UHS Transfer Pump Room

Applicable Regulatory and Code Ref(s):	IBC, RG 1.189; NFPA 10, 13, 14, 72, 80 and 804
--	---

DCD Fig:	9A-201
DCD Sect:	9A.3.96

Associated Safety Division(s)	D
-------------------------------	----------

Wall	Floor	Ceiling
FA7-201-01	-	-

Fire Barrier Description:
Walls of reinforced concrete or other material providing a minimum 3-hour fire resistance rating form the boundaries of this room. The door to the room is 3-hour fire rated and all openings and penetrations into the room are rated to provide 3-hour fire resistance.

Adjacent Fire Zones:
(Primary Inter face Listed See Table 9A-203 For Complete Listing)

Potential Combustibles	
Item	Heat Release (Btu)
Lube Oil	5.15E+05
Grease	1.84E+06
High Voltage Cable	2.46E+06
Low Voltage Cable	2.14E+06
Control Cable	3.09E+06
Instrumentation Cable	3.29E+06

Fire Detection - Primary	
Automatic Fire Detection System	Fire Detection - Backup
Wet Pipe Sprinkler	Fire Hose Station

Fire Impact to Zone	
Suppression System Operates	Suppression System Fails to Op.
A quickly detected and suppressed fire in this room will minimize fire damage to the safety-related equipment consistent with GDC-3.	A fire in this fire zone could damage the few functions of 1 safe-shutdown train. Trains A, B, C, and D ESW functions remain free of fire damage.

Fire Zone Combustible Summary	
	BTU/ft ²
Anticipated Combustible Loading:	8.9E+04
Maximum Anticipated Combustible Loading:	1.1E+05

Floor Area (ft ²)	150
-------------------------------	------------

**Comanche Peak Nuclear Power Plant, Units 3 & 4
COL Application
Part 2, FSAR**

Table 9A-202 (Sheet 3 of 25)
Fire Hazard Analysis Summary

Fire Zone: FA7-203-01	Building: UHS	Area Designation: A-UHS	Applicable Regulatory and Code Ref(s): IBC, RG 1.189; NFPA 10, 14, and 804
	Floor(s): 1	Zone Designation: A-UHS	
	DCD Fig: 9A-201	Associated Safety Division(s): A	
	DCD Sect: 9A.3.97		

Wall	Floor	Ceiling
FA7-201-01 FA7-206-01	-	-

Fire Barrier Description:
Walls of reinforced concrete or other material providing a minimum 3-hour fire resistance rating form the boundaries of this room. The door to the room is 3-hour fire rated and all openings and penetrations into the room are rated to provide 3-hour fire resistance.

Adjacent Fire Zones:
(Primary Inter face
Listed See Table 9A-203
For Complete Listing)

Potential Combustibles	Heat Release (Btu)
Grease	1.84E+06
High Voltage Cable	2.46E+06
Control Cable	3.09E+06
Instrumentation Cable	3.29E+06

Fire Detection - Primary	Fire Detection - Backup
There is no automatic detection.	Manual Fire Alarm Pull Station
Fire Suppression - Primary	Fire Suppression - Backup
Fire Hose Station	Portable Fire Extinguisher

Fire Impact to Zone	
Suppression System Operates	Suppression System Fails to Op.
A quickly detected and suppressed fire in this room will minimize fire damage to the safety-related equipment consistent with GDC-3.	An un-suppressed fire would self extinguish due to lack of combustible continuity but potentially result in loss of the cooling tower function. Trains B, C, and D remain free of fire damage.

Floor Area (ft ²)	13,600
-------------------------------	---------------

Fire Zone Combustible Summary	
	BTU/ft ²
Anticipated Combustible Loading:	7.9E+02
Maximum Anticipated Combustible Loading:	9.5E+02

**Comanche Peak Nuclear Power Plant, Units 3 & 4
COL Application
Part 2, FSAR**

Table 9A-202 (Sheet 4 of 25)
Fire Hazard Analysis Summary

Fire Zone: **FA7-204-01**

Building:	ESW Pumping Station
Floor(s):	1
DCD Fig:	9A-201
DCD Sect:	9A.3.98

Area Designation: **B-ESW Pump Room**

Zone Designation: **B-ESW Pump Room**

Associated Safety Division(s): **B**

Applicable Regulatory and Code Ref(s):	IBC, RG 1.189; NFPA 10, 13, 14, 72 and 804
--	---

Wall	Floor	Ceiling
FA7-205-01 FA7-206-01	-	-

Fire Barrier Description:
Walls of reinforced concrete or other material providing a minimum 3-hour fire resistance rating form the boundaries of this room. The door to the room is 3-hour fire rated and all openings and penetrations into the room are rated to provide 3-hour fire resistance.

Adjacent Fire Zones:
(Primary Inter face
Listed See Table 9A-203
For Complete Listing)

Potential Combustibles	Heat Release (Btu)
Lube Oil	5.15E+05
Grease	1.84E+06
High Voltage Cable	2.46E+06
Low Voltage Cable	2.14E+06
Control Cable	3.09E+06
Instrumentation Cable	3.29E+06

Fire Detection - Primary	Fire Detection - Backup
Automatic Fire Detection System	Manual Fire Alarm Pull Station
Fire Suppression – Primary	Fire Suppression - Backup
Wet Pipe Sprinkler	Fire Hose Station

Fire Impact to Zone	
Suppression System Operates	Suppression System Fails to Op.
A quickly detected and suppressed fire in this room will minimize fire damage to the safety-related equipment consistent with GDC-3.	A fire in this fire zone could damage the few functions of 1 safe-shutdown train. Three trains remain free from the fire damage.

Floor Area (ft ²)	1650
-------------------------------	-------------

Fire Zone Combustible Summary	
Anticipated Combustible Loading:	BTU/ft ²
Maximum Anticipated Combustible Loading:	8.1E+03
	9.8E+03

**Comanche Peak Nuclear Power Plant, Units 3 & 4
COL Application
Part 2, FSAR**

Table 9A-202 (Sheet 5 of 25)
Fire Hazard Analysis Summary

Fire Zone: **FA7-205-01**
 Building: **ESW Pumping Station**
 Floor(s): **1**
 DCD Fig: **9A-201**
 DCD Sect: **9A.3.99**

Area Designation: **B-UHS Transfer Pump Room**
 Zone Designation: **B-UHS Transfer Pump Room**
 Associated Safety Division(s): **D**

Applicable Regulatory and Code Ref(s):
IBC, RG 1.189; NFPA 10, 13, 14, 72, 80 and 804

Wall	Floor	Ceiling
FA7-204-01	-	-

Fire Barrier Description:
Walls of reinforced concrete or other material providing a minimum 3-hour fire resistance rating form the boundaries of this room. The door to the room is 3-hour fire rated and all openings and penetrations into the room are rated to provide 3-hour fire resistance.

Adjacent Fire Zones:
 (Primary Inter face
 Listed See Table 9A-203
 For Complete Listing)

Potential Combustibles	
Item	Heat Release (Btu)
Lube Oil	5.15E+05
Grease	1.84E+06
High Voltage Cable	2.46E+06
Low Voltage Cable	2.14E+06
Control Cable	3.09E+06
Instrumentation Cable	3.29E+06

Fire Detection - Primary	Fire Detection - Backup
Automatic Fire Detection System	Manual Fire Alarm Pull Station
Wet Pipe Sprinkler	Fire Hose Station

Fire Impact to Zone	
Suppression System Operates	Suppression System Fails to Op.
A quickly detected and suppressed fire in this room will minimize fire damage to the safety-related equipment consistent with GDC-3.	A fire in this fire zone could damage the few functions of 1 safe-shutdown train. Trains A, B, C, and D ESW functions remain free of fire damage.

Floor Area (ft ²)	150
-------------------------------	------------

Fire Zone Combustible Summary	
	BTU/ft ²
Anticipated Combustible Loading:	8.9E+04
Maximum Anticipated Combustible Loading:	1.1E+05

**Comanche Peak Nuclear Power Plant, Units 3 & 4
COL Application
Part 2, FSAR**

Table 9A-202 (Sheet 6 of 25)
Fire Hazard Analysis Summary

Fire Zone: FA7-206-01	Area Designation: B-UHS	Applicable Regulatory and Code Ref(s): IBC, RG 1.189; NFPA 10, 14, and 804
Building: UHS	Zone Designation: B-UHS	
Floor(s): 1	Associated Safety Division(s): B	
DCD Fig: 9A-201		
DCD Sect: 9A.3.100		

Adjacent Fire Zones: (Primary Inter face Listed See Table 9A-203 For Complete Listing)	Wall	Floor	Ceiling	Fire Barrier Description:
	FA7-203-01 FA7-204-01	-	-	Walls of reinforced concrete or other material providing a minimum 3-hour fire resistance rating form the boundaries of this room. The door to the room is 3-hour fire rated and all openings and penetrations into the room are rated to provide 3-hour fire resistance.

Potential Combustibles	
Item	Heat Release (Btu)
Grease	1.84E+06
High Voltage Cable	2.46E+06
Control Cable	3.09E+06
Instrumentation Cable	3.29E+06

Fire Zone Combustible Summary	
	BTU/ft ²
Anticipated Combustible Loading:	7.9E+02
Maximum Anticipated Combustible Loading:	9.5E+02

Fire Detection - Primary	Fire Detection - Backup
There is no automatic detection.	Manual Fire Alarm Pull Station
Fire Suppression - Primary	Fire Suppression - Backup
Fire Hose Station	Portable Fire Extinguisher

Fire Impact to Zone	
Suppression System Operates	Suppression System Fails to Op.
A quickly detected and suppressed fire in this room will minimize fire damage to the safety-related equipment consistent with GDC-3.	An unsuppressed fire would self extinguish due to lack of combustible continuity but potentially result in loss of the cooling tower function. Trains A, C, and D remain free of fire damage.

Floor Area (ft ²)	13,600
-------------------------------	---------------

**Comanche Peak Nuclear Power Plant, Units 3 & 4
COL Application
Part 2, FSAR**

Table 9A-202 (Sheet 7 of 25)
Fire Hazard Analysis Summary

Fire Zone: FA7-207-01	Area Designation: C-ESW Pump Room	Applicable Regulatory and Code Ref(s): IBC, RG 1.189; NFPA 10, 13, 14, 72 and 804
Building: ESW Pumping Station	Zone Designation: C-ESW Pump Room	
Floor(s): 1	Associated Safety Division(s): C	
DCD Fig: 9A-201		
DCD Sect: 9A.3.101		

Adjacent Fire Zones:
(Primary Inter face Listed See Table 9A-203 For Complete Listing)

Wall	Floor	Ceiling
FA7-208-01	-	-
FA7-209-01		
FA7-212-01		

Fire Barrier Description:
Walls of reinforced concrete or other material providing a minimum 3-hour fire resistance rating form the boundaries of this room. The door to the room is 3-hour fire rated and all openings and penetrations into the room are rated to provide 3-hour fire resistance.

Potential Combustibles	
Item	Heat Release (Btu)
Lube Oil	5.15E+05
Grease	1.84E+06
High Voltage Cable	2.46E+06
Low Voltage Cable	2.14E+06
Control Cable	3.09E+06
Instrumentation Cable	3.29E+06

Fire Zone Combustible Summary	
	BTU/ft ²
Anticipated Combustible Loading:	8.1E+03
Maximum Anticipated Combustible Loading:	9.8E+03

Fire Detection - Primary	Fire Detection - Backup
Automatic Fire Detection System	Manual Fire Alarm Pull Station
Fire Suppression - Primary	Fire Suppression - Backup
Wet Pipe Sprinkler	Fire Hose Station

Fire Impact to Zone	
Suppression System Operates	Suppression System Fails to Op.
A quickly detected and suppressed fire in this room will minimize fire damage to the safety-related equipment consistent with GDC-3.	A fire in this fire zone could damage the few functions of 1 safe-shutdown train. Three trains remain free from the fire damage.

Floor Area (ft ²)	1650
-------------------------------	-------------

**Comanche Peak Nuclear Power Plant, Units 3 & 4
COL Application
Part 2, FSAR**

Table 9A-202 (Sheet 8 of 25)
Fire Hazard Analysis Summary

Fire Zone: **FA7-208-01**

Building: **ESW Pumping Station**

Floor(s): **1**

DCD Fig: **9A-201**

DCD Sect: **9A.3.102**

Area Designation: **C-UHS Transfer Pump Room**

Zone Designation: **C-UHS Transfer Pump Room**

Associated Safety Division(s): **A**

Applicable Regulatory and Code Ref(s): **IBC, RG 1.189; NFPA 10, 13, 14, 72, 80 and 804**

Wall: **FA7-207-01**

Floor: **-**

Ceiling: **-**

Fire Barrier Description: **Walls of reinforced concrete or other material providing a minimum 3-hour fire resistance rating form the boundaries of this room. The door to the room is 3-hour fire rated and all openings and penetrations into the room are rated to provide 3-hour fire resistance.**

Adjacent Fire Zones:
(Primary Inter face Listed See Table 9A-203 For Complete Listing)

Potential Combustibles	
Item	Heat Release (Btu)
Lube Oil	5.15E+05
Grease	1.84E+06
High Voltage Cable	2.46E+06
Low Voltage Cable	2.14E+06
Control Cable	3.09E+06
Instrumentation Cable	3.29E+06

Fire Detection - Primary	Fire Detection - Backup
Automatic Fire Detection System	Manual Fire Alarm Pull Station
Fire Suppression - Primary	Fire Suppression - Backup
Wet Pipe Sprinkler	Fire Hose Station

Fire Impact to Zone	
Suppression System Operates	Suppression System Fails to Op.
A quickly detected and suppressed fire in this room will minimize fire damage to the safety-related equipment consistent with GDC-3.	A fire in this fire zone could damage the few functions of 1 safe-shutdown train. Trains A, B, C, and D ESW functions remain free of fire damage.

Floor Area (ft ²)	150
-------------------------------	------------

Fire Zone Combustible Summary	
	BTU/ft ²
Anticipated Combustible Loading:	8.9E+04
Maximum Anticipated Combustible Loading:	1.1E+05

**Comanche Peak Nuclear Power Plant, Units 3 & 4
COL Application
Part 2, FSAR**

**Table 9A-202 (Sheet 9 of 25)
Fire Hazard Analysis Summary**

Fire Zone: **FA7-209-01**

Building:	UHS
Floor(s):	1
DCD Fig:	9A-201
DCD Sect:	9A.3.103

Area Designation:	C-UHS
Zone Designation:	C-UHS
Associated Safety Division(s)	C

Applicable Regulatory and Code Ref(s):	IBC, RG 1.189; NFPA 10, 14, and 804
--	--

Wall	Floor	Ceiling
FA7-207-01 FA7-212-01	-	-

Adjacent Fire Zones:
(Primary Inter face
Listed See Table 9A-203
For Complete Listing)

Fire Barrier Description:
Walls of reinforced concrete or other material providing a minimum 3-hour fire resistance rating form the boundaries of this room. The door to the room is 3-hour fire rated and all openings and penetrations into the room are rated to provide 3-hour fire resistance.

Potential Combustibles	
Item	Heat Release (Btu)
Grease	1.84E+06
High Voltage Cable	2.46E+06
Control Cable	3.09E+06
Instrumentation Cable	3.29E+06

Fire Detection - Primary	Fire Detection - Backup
There is no automatic detection.	Manual Fire Alarm Pull Station
Fire Suppression - Primary	Fire Suppression - Backup
Fire Hose Station	Portable Fire Extinguisher

Fire Impact to Zone	
Suppression System Operates	Suppression System Fails to Op.
A quickly detected and suppressed fire in this room will minimize fire damage to the safety-related equipment consistent with GDC-3.	An unsupported fire would self extinguish due to lack of combustible continuity but potentially result in loss of the cooling tower function. Trains A, B, and D remain free of fire damage.

Floor Area (ft ²)	13,600
-------------------------------	---------------

Fire Zone Combustible Summary	
	BTU/ft ²
Anticipated Combustible Loading:	7.9E+02
Maximum Anticipated Combustible Loading:	9.5E+02

**Comanche Peak Nuclear Power Plant, Units 3 & 4
COL Application
Part 2, FSAR**

Table 9A-202 (Sheet 10 of 25)
Fire Hazard Analysis Summary

Fire Zone: **FA7-210-01**

Building: **ESW Pumping Station**

Floor(s): **1**

DCD Fig: **9A-201**

DCD Sect: **9A.3.104**

Area Designation: **D-ESW Pump Room**

Zone Designation: **D-ESW Pump Room**

Associated Safety Division(s): **D**

Applicable Regulatory and Code Ref(s): **IBC, RG 1.189; NFPA 10, 13, 14, 72 and 804**

Wall	Floor	Ceiling
FA7-211-01 FA7-212-01	-	-

Adjacent Fire Zones:
(Primary Inter face
Listed See Table 9A-203
For Complete Listing)

Fire Barrier Description:
Walls of reinforced concrete or other material providing a minimum 3-hour fire resistance rating form the boundaries of this room. The door to the room is 3-hour fire rated and all openings and penetrations into the room are rated to provide 3-hour fire resistance.

Potential Combustibles	
Item	Heat Release (Btu)
Lube Oil	5.15E+05
Grease	1.84E+06
High Voltage Cable	2.46E+06
Low Voltage Cable	2.14E+06
Control Cable	3.09E+06
Instrumentation Cable	3.29E+06

Fire Detection - Primary	Fire Detection - Backup
Automatic Fire Detection System	Manual Fire Alarm Pull Station
Fire Suppression - Primary	Fire Suppression - Backup
Wet Pipe Sprinkler	Fire Hose Station

Fire Impact to Zone	
Suppression System Operates	Suppression System Fails to Op.
A quickly detected and suppressed fire in this room will minimize fire damage to the safety-related equipment consistent with GDC-3.	A fire in this fire zone could damage the few functions of 1 safe-shutdown train. Three trains remain free from the fire damage.

Floor Area (ft ²)	1650
-------------------------------	-------------

Fire Zone Combustible Summary	
	BTU/ft ²
Anticipated Combustible Loading:	8.1E+03
Maximum Anticipated Combustible Loading:	9.8E+03

**Comanche Peak Nuclear Power Plant, Units 3 & 4
COL Application
Part 2, FSAR**

Table 9A-202 (Sheet 11 of 25)
Fire Hazard Analysis Summary

Fire Zone: **FA7-211-01**
 Building: **ESW Pumping Station**
 Floor(s): **1**
 DCD Fig: **9A-201**
 DCD Sect: **9A.3.105**

Area Designation: **D-UHS Transfer Pump Room**
 Zone Designation: **D-UHS Transfer Pump Room**

Associated Safety Division(s) **A**

Applicable Regulatory and Code Ref(s):
IBC, RG 1.189; NFPA 10, 13, 14, 72, 80 and 804

Wall	Floor	Ceiling
FA7-210-01	-	-

Fire Barrier Description:
Walls of reinforced concrete or other material providing a minimum 3-hour fire resistance rating form the boundaries of this room. The door to the room is 3-hour fire rated and all openings and penetrations into the room are rated to provide 3-hour fire resistance.

Adjacent Fire Zones:
 (Primary Inter face
 Listed See Table 9A-203
 For Complete Listing)

Potential Combustibles	
Item	Heat Release (Btu)
Lube Oil	5.15E+05
Grease	1.84E+06
High Voltage Cable	2.46E+06
Low Voltage Cable	2.14E+06
Control Cable	3.09E+06
Instrumentation Cable	3.29E+06

Fire Detection - Primary	Fire Detection - Backup
Automatic Fire Detection System	Manual Fire Alarm Pull Station
Fire Suppression - Primary	Fire Suppression - Backup
Wet Pipe Sprinkler	Fire Hose Station

Fire Impact to Zone	
Suppression System Operates	Suppression System Fails to Op.
A quickly detected and suppressed fire in this room will minimize fire damage to the safety-related equipment consistent with GDC-3.	A fire in this fire zone could damage the few functions of 1 safe-shutdown train. Trains A, B, C, and D ESW functions remain free of fire damage.

Floor Area (ft ²)	150
-------------------------------	------------

Fire Zone Combustible Summary	
	BTU/ft ²
Anticipated Combustible Loading:	8.9E+04
Maximum Anticipated Combustible Loading:	1.1E+05

**Comanche Peak Nuclear Power Plant, Units 3 & 4
COL Application
Part 2, FSAR**

Table 9A-202 (Sheet 12 of 25)
Fire Hazard Analysis Summary

Fire Zone: **FA7-212-01**

Building: **UHS**

Floor(s): **1**

DCD Fig: **9A-201**

DCD Sect: **9A.3.106**

Area Designation: **D-UHS**

Zone Designation: **D-UHS**

Associated Safety Division(s) **D**

Applicable Regulatory and Code Ref(s):
IBC, RG 1.189; NFPA 10, 14, and 804

Wall	Floor	Ceiling
FA7-207-01	-	-
FA7-209-01	-	-
FA7-210-01	-	-

Fire Barrier Description:
Walls of reinforced concrete or other material providing a minimum 3-hour fire resistance rating form the boundaries of this room. The door to the room is 3-hour fire rated and all openings and penetrations into the room are rated to provide 3-hour fire resistance.

Adjacent Fire Zones:
(Primary Inter face Listed See Table 9A-203 For Complete Listing)

Potential Combustibles	
Item	Heat Release (Btu)
Grease	1.84E+06
High Voltage Cable	2.46E+06
Control Cable	3.09E+06
Instrumentation Cable	3.29E+06

Fire Detection - Primary	There is no automatic detection.	Fire Detection - Backup	Manual Fire Alarm Pull Station
Fire Suppression - Primary	Fire Hose Station	Fire Suppression - Backup	Portable Fire Extinguisher

Fire Zone Combustible Summary	
	BTU/ft ²
Anticipated Combustible Loading:	7.9E+02
Maximum Anticipated Combustible Loading:	9.5E+02

Floor Area (ft ²)	13,600
-------------------------------	---------------

Fire Impact to Zone	
Suppression System Operates	Suppression System Fails to Op.
A quickly detected and suppressed fire in this room will minimize fire damage to the safety-related equipment consistent with GDC-3.	An unsuppressed fire would self extinguish due to lack of combustible continuity but potentially result in loss of the cooling tower function. Trains A, B, and C remain free of fire damage.

**Comanche Peak Nuclear Power Plant, Units 3 & 4
COL Application
Part 2, FSAR**

Table 9A-202 (Sheet 13 of 25)
Fire Hazard Analysis Summary

Fire Zone: **FA7-301-01**

Building:	Transformer Yard
Floor(s):	N/A

Area Designation:	Transformer Yard
Zone Designation:	Main Generator Excitation Transformer Zone

Applicable Regulatory and Code Ref(s):	IBC, RG 1.189; NFPA 10, 15, 24, 72 and 804
--	---

DCD Fig:	9A-202
DCD Sect:	9A.3.107

Associated Safety Division(s) **N**

Wall	Floor	Ceiling
FA6-101-02 FA7-301-02 FA7-301-09	-	-

Fire Barrier Description:
This zone is surrounded with freestanding fire barriers and open space. A freestanding firewall rated for 3-hours separate this zone from the turbine building and a freestanding 1-hour rated firewall separates this zone from surrounding transformers.

Adjacent Fire Zones:
(Primary Inter face Listed See Table 9A-203 For Complete Listing)

Potential Combustibles	
Item	Heat Release (Btu)
Transformer Oil	7.84E+08

Fire Detection - Primary	Automatic heat	Fire Detection - Backup	Manual Fire Alarm Pull Station
Fire Suppression - Primary	Water Spray System	Fire Suppression - Backup	Yard Hydrant

Fire Impact to Zone	
Suppression System Operates	Suppression System Fails to Op.
A quickly detected and suppressed fire in this room will minimize fire damage to the transformer.	There is no safe-shutdown circuit in this zone to be damaged.

Floor Area (ft ²)	1650
-------------------------------	-------------

Fire Zone Combustible Summary	
	BTU/ft ²
Anticipated Combustible Loading:	4.8E+05
Maximum Anticipated Combustible Loading:	5.7E+05

**Comanche Peak Nuclear Power Plant, Units 3 & 4
COL Application
Part 2, FSAR**

Table 9A-202 (Sheet 14 of 25)
Fire Hazard Analysis Summary

Fire Zone:	FA7-301-02
Building:	Transformer Yard
Floor(s):	N/A
DCD Fig:	9A-202
DCD Sect:	9A.3.107

Area Designation:	Transformer Yard
Zone Designation:	A-Unit Auxiliary Transformer Zone
Associated Safety Division(s)	N

Applicable Regulatory and Code Ref(s):	IBC, RG 1.189; NFPA 10, 15, 24, 72 and 804
--	---

Wall	Floor	Ceiling
FA6-101-02	-	-
FA7-301-01		
FA7-301-03		
FA7-301-08		
FA7-301-09		

Fire Barrier Description:
This zone is surrounded with freestanding fire barriers and open space. A freestanding firewall rated for 3-hours separate this zone from the turbine building and a freestanding 1-hour rated firewall separates this zone from surrounding transformers.

Adjacent Fire Zones:
(Primary Inter face Listed See Table 9A-203 For Complete Listing)

Potential Combustibles	
Item	Heat Release (Btu)
Transformer Oil	7.84E+08

Fire Detection - Primary	Fire Detection - Backup
Automatic heat	Manual Fire Alarm Pull Station
Fire Suppression - Primary	Fire Suppression - Backup
Water Spray System	Yard Hydrant

Fire Impact to Zone	
Suppression System Operates	Suppression System Fails to Op.
A quickly detected and suppressed fire in this room will minimize fire damage to the transformer.	There is no safe-shutdown circuit in this zone to be damaged.

Floor Area (ft ²)	1650
-------------------------------	-------------

Fire Zone Combustible Summary	
	BTU/ft ²
Anticipated Combustible Loading:	4.8E+05
Maximum Anticipated Combustible Loading:	5.7E+05

**Comanche Peak Nuclear Power Plant, Units 3 & 4
COL Application
Part 2, FSAR**

Table 9A-202 (Sheet 15 of 25)
Fire Hazard Analysis Summary

Fire Zone: **FA7-301-03**

Building: **Transformer Yard**

Floor(s): **N/A**

DCD Fig: **9A-202**

DCD Sect: **9A.3.107**

Area Designation: **Transformer Yard**

Zone Designation: **B-Unit Auxiliary Transformer Zone**

Associated Safety Division(s): **N**

Applicable Regulatory and Code Ref(s):
IBC, RG 1.189; NFPA 10, 15, 24, 72 and 804

Adjacent Fire Zones:
(Primary Inter face Listed See Table 9A-203 For Complete Listing)

Wall	Floor	Ceiling
FA6-101-02	-	-
FA7-301-02		
FA7-301-04		
FA7-301-07		
FA7-301-08		

Fire Barrier Description:
This zone is surrounded with freestanding fire barriers and open space. A freestanding firewall rated for 3-hours separate this zone from the turbine building and a freestanding 1-hour rated firewall separates this zone from surrounding transformers.

Potential Combustibles	
Item	Heat Release (Btu)
Transformer Oil	7.84E+08

Fire Detection - Primary	Fire Detection - Backup
Automatic heat	Manual Fire Alarm Pull Station
Fire Suppression - Primary	Fire Suppression - Backup
Water Spray System	Yard Hydrant

Fire Impact to Zone	
Suppression System Operates	Suppression System Fails to Op.
A quickly detected and suppressed fire in this room will minimize fire damage to the transformer.	There is no safe-shutdown circuit in this zone to be damaged.

Floor Area (ft ²)
1650

Fire Zone Combustible Summary	
	BTU/ft ²
Anticipated Combustible Loading:	4.8E+05
Maximum Anticipated Combustible Loading:	5.7E+05

**Comanche Peak Nuclear Power Plant, Units 3 & 4
COL Application
Part 2, FSAR**

**Table 9A-202 (Sheet 16 of 25)
Fire Hazard Analysis Summary**

Fire Zone: **FA7-301-04**

Building: **Transformer Yard**

Floor(s): **N/A**

DCD Fig: **9A-202**

DCD Sect: **9A.3.107**

Area Designation: **Transformer Yard**

Zone Designation: **C-Unit Auxiliary Transformer Zone**

Associated Safety Division(s): **N**

Applicable Regulatory and Code Ref(s):
IBC, RG 1.189; NFPA 10, 15, 24, 72 and 804

Wall	Floor	Ceiling
FA6-101-02	-	-
FA7-301-03		
FA7-301-05		
FA7-301-07		

Adjacent Fire Zones:
(Primary Inter face
Listed See Table
9A-203
For Complete Listing)

Fire Barrier Description:
This zone is surrounded with freestanding fire barriers and open space. A freestanding firewall rated for 3-hours separate this zone from the turbine building and a freestanding 1-hour rated firewall separates this zone from surrounding transformers.

Potential Combustibles	
Item	Heat Release (Btu)
Transformer Oil	9.60E+08

Fire Detection - Primary	Fire Detection - Backup
Automatic heat	Manual Fire Alarm Pull Station
Fire Suppression - Primary	Fire Suppression - Backup
Water Spray System	Yard Hydrant

Fire Impact to Zone	
Suppression System Operates	Suppression System Fails to Op.
A quickly detected and suppressed fire in this room will minimize fire damage to the transformer.	There is no safe-shutdown circuit in this zone to be damaged.

Floor Area (ft ²)	1650
-------------------------------	-------------

Fire Zone Combustible Summary	
	BTU/ft ²
Anticipated Combustible Loading:	5.8E+05
Maximum Anticipated Combustible Loading:	7.0E+05

**Comanche Peak Nuclear Power Plant, Units 3 & 4
COL Application
Part 2, FSAR**

Table 9A-202 (Sheet 17 of 25)
Fire Hazard Analysis Summary

Fire Zone:	FA7-301-05
Building:	Transformer Yard
Floor(s):	N/A

Area Designation:

Transformer Yard
Spare Unit Auxiliary Transformer Zone

Zone Designation:

N

Associated Safety Division(s)

DCD Fig:	9A-202
DCD Sect:	9A.3.107

Applicable Regulatory and Code Ref(s):	IBC, RG 1.189; NFPA 10, 15, 24, 72 and 804
--	---

Wall	Floor	Ceiling
FA7-301-04	-	-
FA7-301-06		
FA7-301-10		

Adjacent Fire Zones:
(Primary Inter face
Listed See Table 9A-203
For Complete Listing)

Fire Barrier Description:	This zone is surrounded with freestanding fire barriers and open space. A freestanding 1-hour rated firewall separates this zone from surrounding transformers.
---------------------------	--

Potential Combustibles	
Item	Heat Release (Btu)
Transformer Oil	9.60E+08

Fire Detection - Primary	Automatic heat	Fire Detection - Backup	Manual Fire Alarm Pull Station
Fire Suppression - Primary	Water Spray System	Fire Suppression - Backup	Yard Hydrant

Fire Zone Combustible Summary	
	BTU/ft ²
Anticipated Combustible Loading:	5.8E+05
Maximum Anticipated Combustible Loading:	7.0E+05

Floor Area (ft ²)	1650
-------------------------------	-------------

Fire Impact to Zone	Suppression System Operates	Suppression System Fails to Op.
	A quickly detected and suppressed fire in this room will minimize fire damage to the transformer.	There is no safe-shutdown circuit in this zone to be damaged.

**Comanche Peak Nuclear Power Plant, Units 3 & 4
COL Application
Part 2, FSAR**

Table 9A-202 (Sheet 18 of 25)
Fire Hazard Analysis Summary

Fire Zone:	FA7-301-06
Building:	Transformer Yard
Floor(s):	N/A
DCD Fig:	9A-202
DCD Sect:	9A.3.107

Area Designation: **Transformer Yard**
Zone Designation: **Spare Main Transformer Zone**
Associated Safety Division(s): **N**

Applicable Regulatory and Code Ref(s):
IBC, RG 1.189; NFPA 10, 15, 24, 72 and 804

Wall	Floor	Ceiling
FA7-301-05	-	-
FA7-301-07		
FA7-301-10		
FA7-301-11		

Adjacent Fire Zones:
(Primary Inter face
Listed See Table 9A-203
For Complete Listing)

Fire Barrier Description:
This zone is surrounded with freestanding fire barriers and open space. A freestanding 1-hour rated firewall separates this zone from surrounding transformers.

Potential Combustibles	
Item	Heat Release (Btu)
Transformer Oil	1.88E+09

Fire Detection - Primary	Fire Detection - Backup
Automatic heat	Manual Fire Alarm Pull Station
Fire Suppression - Primary	Fire Suppression - Backup
Water Spray System	Yard Hydrant

Fire Impact to Zone	
Suppression System Operates	Suppression System Fails to Op.
A quickly detected and suppressed fire in this room will minimize fire damage to the transformer.	There is no safe-shutdown circuit in this zone to be damaged.

Floor Area (ft ²)
2700

Fire Zone Combustible Summary	
	BTU/ft ²
Anticipated Combustible Loading:	7.0E+05
Maximum Anticipated Combustible Loading:	8.4E+05

**Comanche Peak Nuclear Power Plant, Units 3 & 4
COL Application
Part 2, FSAR**

Table 9A-202 (Sheet 19 of 25)
Fire Hazard Analysis Summary

Fire Zone:	FA7-301-07
Building:	Transformer Yard
Floor(s):	N/A
DCD Fig:	9A-202
DCD Sect:	9A.3.107

Area Designation:	Transformer Yard
Zone Designation:	C-Main Transformer Zone
Associated Safety Division(s)	N

Applicable Regulatory and Code Ref(s):	IBC, RG 1.189; NFPA 10, 14, 15, 24, 72 and 804
--	---

Wall	Floor	Ceiling
FA7-301-03	-	-
FA7-301-04		
FA7-301-06		
FA7-301-08		

Fire Barrier Description:
This zone is surrounded with freestanding fire barriers and open space. A freestanding 1-hour rated firewall separates this zone from surrounding transformers.

Adjacent Fire Zones:
(Primary Inter face
Listed See Table 9A-203
For Complete Listing)

Potential Combustibles	
Item	Heat Release (Btu)
Transformer Oil	1.88E+09

Fire Detection - Primary	Automatic heat	Fire Detection - Backup	Manual Fire Alarm Pull Station
Fire Suppression - Primary	Water Spray System	Fire Suppression - Backup	Yard Hydrant

Suppression System Operates	A quickly detected and suppressed fire in this room will minimize fire damage to the transformer.	Fire Impact to Zone	Suppression System Fails to Op. There is no safe-shutdown circuit in this zone to be damaged.
-----------------------------	--	---------------------	--

Floor Area (ft ²)	2700
-------------------------------	-------------

Fire Zone Combustible Summary	
	BTU/ft ²
Anticipated Combustible Loading:	7.0E+05
Maximum Anticipated Combustible Loading:	8.4E+05

**Comanche Peak Nuclear Power Plant, Units 3 & 4
COL Application
Part 2, FSAR**

Table 9A-202 (Sheet 20 of 25)
Fire Hazard Analysis Summary

Fire Zone:	FA7-301-08
Building:	Transformer Yard
Floor(s):	N/A
DCD Fig:	9A-202
DCD Sect:	9A.3.107

Area Designation:	Transformer Yard
Zone Designation:	B-Main Transformer Zone
Associated Safety Division(s)	N

Applicable Regulatory and Code Ref(s):	IBC, RG 1.189; NFPA 10, 14, 15, 24, 72 and 804
--	---

Wall	Floor	Ceiling
FA7-301-02 FA7-301-03 FA7-301-07 FA7-301-09	-	-

Fire Barrier Description:
This zone is surrounded with freestanding fire barriers and open space. A freestanding 1-hour rated firewall separates this zone from surrounding transformers.

Adjacent Fire Zones:
(Primary Inter face
Listed See Table 9A-203
For Complete Listing)

Potential Combustibles	
Item	Heat Release (Btu)
Transformer Oil	1.88E+09

Fire Detection - Primary	Fire Detection - Backup
Automatic heat	Manual Fire Alarm Pull Station
Fire Suppression - Primary	Fire Suppression - Backup
Water Spray System	Yard Hydrant

Suppression System Operates	Fire Impact to Zone
A quickly detected and suppressed fire in this room will minimize fire damage to the transformer.	Suppression System Fails to Op. There is no safe-shutdown circuit in this zone to be damaged.

Floor Area (ft ²)
2700

Fire Zone Combustible Summary	
	BTU/ft ²
Anticipated Combustible Loading:	7.0E+05
Maximum Anticipated Combustible Loading:	8.4E+05

**Comanche Peak Nuclear Power Plant, Units 3 & 4
COL Application
Part 2, FSAR**

Table 9A-202 (Sheet 21 of 25)
Fire Hazard Analysis Summary

Fire Zone:	FA7-301-09
Building:	Transformer Yard
Floor(s):	N/A
DCD Fig:	9A-202
DCD Sect:	9A.3.107

Area Designation: **Transformer Yard**
Zone Designation: **A-Main Transformer Zone**
Associated Safety Division(s): **N**

Applicable Regulatory and Code Ref(s): IBC, RG 1.189; NFPA 10, 14, 15, 24, 72 and 804

Wall	Floor	Ceiling
FA7-301-01	-	-
FA7-301-02		
FA7-301-08		

Adjacent Fire Zones:
(Primary Inter face
Listed See Table 9A-203
For Complete Listing)

Fire Barrier Description: This zone is surrounded with freestanding fire barriers and open space. A freestanding 1-hour rated firewall separates this zone from surrounding transformers.
--

Potential Combustibles	
Item	Heat Release (Btu)
Transformer Oil	1.88E+09

Fire Detection - Primary Automatic heat	Fire Detection - Backup Manual Fire Alarm Pull Station
Fire Suppression - Primary Water Spray System	Fire Suppression - Backup Yard Hydrant

Fire Zone Combustible Summary	
	BTU/ft ²
Anticipated Combustible Loading:	7.0E+05
Maximum Anticipated Combustible Loading:	8.4E+05

Floor Area (ft ²)	2700
-------------------------------	-------------

Suppression System Operates A quickly detected and suppressed fire in this room will minimize fire damage to the transformer.	Fire Impact to Zone Suppression System Fails to Op. There is no safe-shutdown circuit in this zone to be damaged.
---	--

**Comanche Peak Nuclear Power Plant, Units 3 & 4
COL Application
Part 2, FSAR**

Table 9A-202 (Sheet 22 of 25)
Fire Hazard Analysis Summary

Fire Zone:	FA7-301-10
Building:	Transformer Yard
Floor(s):	N/A
DCD Fig:	9A-202
DCD Sect:	9A.3.107

Area Designation: **Transformer Yard**
 Zone Designation: **Reserve Auxiliary Transformer 1 Zone**
 Associated Safety Division(s): **N**

Applicable Regulatory and Code Ref(s):	IBC, RG 1.189; NFPA 10, 15, 24, 72 and 804
--	---

Wall	Floor	Ceiling
FA7-301-05 FA7-301-06 FA7-301-11 FA7-301-13	-	-

Adjacent Fire Zones:
 (Primary Inter face
 Listed See Table
 9A-203
 For Complete Listing)

Fire Barrier Description:
This zone is surrounded with freestanding fire barriers and open space. A freestanding 1-hour rated firewall separates this zone from surrounding transformers.

Potential Combustibles	
Item	Heat Release (Btu)
Transformer Oil	1.38E+09

Fire Detection - Primary	Fire Detection - Backup
Automatic heat	Manual Fire Alarm Pull Station
Fire Suppression - Primary	Fire Suppression - Backup
Water Spray System	Yard Hydrant

Fire Impact to Zone	
Suppression System Operates	Suppression System Fails to Op.
A quickly detected and suppressed fire in this room will minimize fire damage to the transformer.	There is no safe-shutdown circuit in this zone to be damaged.

Floor Area (ft ²)	2500
-------------------------------	-------------

Fire Zone Combustible Summary	
	BTU/ft ²
Anticipated Combustible Loading:	5.5E+05
Maximum Anticipated Combustible Loading:	6.6E+05

**Comanche Peak Nuclear Power Plant, Units 3 & 4
COL Application
Part 2, FSAR**

Table 9A-202 (Sheet 23 of 25)
Fire Hazard Analysis Summary

Fire Zone: **FA7-301-11**
 Building: **Transformer Yard**
 Floor(s): **N/A**

Area Designation:

Transformer Yard
Reserve Auxiliary Transformer 2 Zone

Applicable Regulatory and Code Ref(s):
IBC, RG 1.189; NFPA 10, 14, 15, 24, 72 and 804

DCD Fig: **9A-202**
 DCD Sect: **9A.3.107**

Zone Designation:

Associated Safety Division(s) **N**

Wall	Floor	Ceiling
FA7-301-06	-	-
FA7-301-10	-	-
FA7-301-12	-	-

Fire Barrier Description:
This zone is surrounded with freestanding fire barriers and open space. A freestanding 1-hour rated firewall separates this zone from surrounding transformers.

Adjacent Fire Zones:
 (Primary Inter face Listed See Table 9A-203 For Complete Listing)

Potential Combustibles	
Item	Heat Release (Btu)
Transformer Oil	1.38E+09

Fire Detection - Primary	Fire Detection - Backup
Automatic heat	Manual Fire Alarm Pull Station
Fire Suppression - Primary	Fire Suppression - Backup
Water Spray System	Yard Hydrant

Fire Impact to Zone	
Suppression System Operates	Suppression System Fails to Op.
A quickly detected and suppressed fire in this room will minimize fire damage to the transformer.	There is no safe-shutdown circuit in this zone to be damaged.

Floor Area (ft ²)	2500
-------------------------------	-------------

Fire Zone Combustible Summary	
	BTU/ft ²
Anticipated Combustible Loading:	5.5E+05
Maximum Anticipated Combustible Loading:	6.6E+05

**Comanche Peak Nuclear Power Plant, Units 3 & 4
COL Application
Part 2, FSAR**

Table 9A-202 (Sheet 24 of 25)
Fire Hazard Analysis Summary

Fire Zone: **FA7-301-12**
 Building: **Transformer Yard**
 Floor(s): **N/A**
 DCD Fig: **9A-202**
 DCD Sect: **9A.3.107**

Area Designation: **Transformer Yard**
 Zone Designation: **Reserve Auxiliary Transformer 4 Zone**
 Associated Safety Division(s): **N**

Applicable Regulatory and Code Ref(s):
IBC, RG 1.189; NFPA 10, 14, 15, 24, 72 and 804

Wall	Floor	Ceiling
FA7-301-11 FA7-301-13	-	-

Fire Barrier Description:
This zone is surrounded with freestanding fire barriers and open space. A freestanding 1-hour rated firewall separates this zone from surrounding transformers.

Adjacent Fire Zones:
 (Primary Inter face Listed See Table 9A-203 For Complete Listing)

Potential Combustibles	
Item	Heat Release (Btu)
Transformer Oil	1.69E+09

Fire Detection - Primary	Fire Detection - Backup
Automatic heat	Manual Fire Alarm Pull Station
Fire Suppression - Primary	Fire Suppression - Backup
Water Spray System	Yard Hydrant

Fire Impact to Zone	
Suppression System Operates	Suppression System Fails to Op.
A quickly detected and suppressed fire in this room will minimize fire damage to the transformer.	There is no or safe-shutdown circuit in this zone to be damaged.

Floor Area (ft ²)	2500
-------------------------------	-------------

Fire Zone Combustible Summary	
	BTU/ft ²
Anticipated Combustible Loading:	6.8E+05
Maximum Anticipated Combustible Loading:	8.1E+05

**Comanche Peak Nuclear Power Plant, Units 3 & 4
COL Application
Part 2, FSAR**

Table 9A-202 (Sheet 25 of 25)
Fire Hazard Analysis Summary

Fire Zone:	FA7-301-13
Building:	Transformer Yard
Floor(s):	N/A
DCD Fig:	9A-202
DCD Sect:	9A.3.107

Area Designation:	Transformer Yard
Zone Designation:	Reserve Auxiliary Transformer 3 Zone
Associated Safety Division(s)	N

Applicable Regulatory and Code Ref(s):	IBC, RG 1.189; NFPA 10, 15, 24, 72 and 804
--	---

Wall	Floor	Ceiling
FA7-301-10 FA7-301-12	-	-

Adjacent Fire Zones:
(Primary Inter face Listed See Table 9A-203 For Complete Listing)

Fire Barrier Description:	This zone is surrounded with freestanding fire barriers and open space. A freestanding 1-hour rated firewall separates this zone from surrounding transformers.
---------------------------	--

Potential Combustibles	
Item	Heat Release (Btu)
Transformer Oil	1.69E+09

Fire Detection - Primary	Fire Detection - Backup
Automatic heat	Manual Fire Alarm Pull Station
Fire Suppression - Primary	Fire Suppression - Backup
Water Spray System	Yard Hydrant

Fire Zone Combustible Summary	
	BTU/ft ²
Anticipated Combustible Loading:	6.8E+05
Maximum Anticipated Combustible Loading:	8.1E+05

Floor Area (ft ²)	2500
-------------------------------	-------------

Fire Impact to Zone	Suppression System Operates
	Suppression System Fails to Op. A quickly detected and suppressed fire in this room will minimize fire damage to the transformer.
	There is no safe-shutdown circuit in this zone to be damaged.

**Comanche Peak Nuclear Power Plant, Units 3 & 4
COL Application
Part 2, FSAR**

Table 9A-203

Fire Zone/Fire Area Interfaces

Fire Zone	Interface	Adjacent Fire Zones
FA6-101-02	Wall	FA7-301-01, FA7-301-02, FA7-301-03, FA7-301-04
FA7-101-01	Wall	FA7-201-01, FA7-202-01,
FA7-102-01	Wall	FA7-204-01, FA7-205-01
FA7-103-01	Wall	FA7-207-01, FA7-208-01
FA7-104-01	Wall	FA7-210-01, FA7-211-01
FA7-201-01	Wall	FA7-202-01, FA7-203-01, FA7-206-01, FA7-101-01
FA7-202-01	Wall	FA7-201-01, FA7-101-01
FA7-203-01	Wall	FA7-201-01, FA7-206-01
FA7-204-01	Wall	FA7-205-01, FA7-206-01, FA7-102-01
FA7-205-01	Wall	FA7-204-01, FA7-102-01
FA7-206-01	Wall	FA7-203-01, FA7-204-01
FA7-207-01	Wall	FA7-208-01, FA7-209-01, FA7-212-01, FA7-103-01
FA7-208-01	Wall	FA7-207-01, FA7-103-01
FA7-209-01	Wall	FA7-207-01, FA7-212-01
FA7-210-01	Wall	FA7-211-01, FA7-212-01, FA7-104-01
FA7-211-01	Wall	FA7-210-01, FA7-104-01
FA7-212-01	Wall	FA7-207-01, FA7-209-01, FA7-210-01
FA7-301-01	Wall	FA6-101-02, FA7-301-02, FA7-301-09
FA7-301-02	Wall	FA6-101-02, FA7-301-01, FA7-301-03, FA7-301-08 FA7-301-09
FA7-301-03	Wall	FA6-101-02, FA7-301-02, FA7-301-04, FA7-301-07 FA7-301-08
FA7-301-04	Wall	FA6-101-02, FA7-301-03, FA7-301-05, FA7-301-07
FA7-301-05	Wall	FA7-301-04, FA7-301-06, FA7-301-10
FA7-301-06	Wall	FA7-301-05, FA7-301-07, FA7-301-10, FA7-301-11
FA7-301-07	Wall	FA7-301-03, FA7-301-04, FA7-301-06, FA7-301-08
FA7-301-08	Wall	FA7-301-02, FA7-301-03, FA7-301-07, FA7-301-09
FA7-301-09	Wall	FA7-301-01, FA7-301-02, FA7-301-08
FA7-301-10	Wall	FA7-301-05, FA7-301-06, FA7-301-11, FA7-301-13
FA7-301-11	Wall	FA7-301-06, FA7-301-10, FA7-301-12
FA7-301-12	Wall	FA7-301-11, FA7-301-13
FA7-301-13	Wall	FA7-301-10, FA7-301-12

Security-Related Information – Withheld Under 10 CFR 2.390(d)(1)

Comanche Peak Nuclear Power Plant, Units 3 & 4
COL Application
Part 2, FSAR



(SRI)

CP COL 9.5(2)

Figure 9A-201 Fire Zones and Fire Areas ESW Pump Rooms and UHS

Security-Related Information – Withheld Under 10 CFR 2.390(d)(1)

**Comanche Peak Nuclear Power Plant, Units 3 & 4
COL Application
Part 2, FSAR**



(SRI)

Figure 9A-202 Fire Zones and Fire Area Transformer Yard