

Southern Nuclear Operating Company
3rd Interval
VOGTLE-2 ISI PLAN, VERSION 3.0

Category, Item No., Class	Summary No./CompID/System	Scope / Method / Procedure	Dwg/ISO No. Comp. Desc. Code Case		Period 1		Period 2		Period 3	
					2VR13	2VR14	2VR14A	2VR15	2VR16	2VR17
F-A	V2 21592-055-H026		2K2-1592-064-01	ISI	-	-	-	-	-	-
F1.30F(2)	21592-055-H026		RESTRAINT	AUG	-	-	-	-	-	-
3	1592			OWN	-	-	-	-	-	-
				PRE	-	-	-	-	-	-
F-A	V2 21592-055-H027		2K2-1592-064-01	ISI	-	-	-	-	-	-
F1.30F(2)	21592-055-H027		RESTRAINT	AUG	-	-	-	-	-	-
3	1592			OWN	-	-	-	-	-	-
				PRE	-	-	-	-	-	-
F-A	V2 21592-055-H028		2K2-1592-064-01	ISI	-	-	-	-	-	-
F1.30F(2)	21592-055-H028		RESTRAINT	AUG	-	-	-	-	-	-
3	1592			OWN	-	-	-	-	-	-
				PRE	-	-	-	-	-	-
F-A	V2 21202-002-H004	ISI/VT/	2K3-1202-002-01	ISI	-	-	-	s	-	-
F1.30G(2)	21202-002-H004		STRUT	AUG	-	-	-	-	-	-
3	1202			OWN	-	-	-	-	-	-
				PRE	-	-	-	-	-	-
F-A	V2 21202-002-H009		2K3-1202-002-02	ISI	-	-	-	-	-	-
F1.30G(2)	21202-002-H009		STRUT	AUG	-	-	-	-	-	-
3	1202			OWN	-	-	-	-	-	-
				PRE	-	-	-	-	-	-
F-A	V2 21202-002-H010		2K3-1202-002-02	ISI	-	-	-	-	-	-
F1.30G(2)	21202-002-H010		STRUT	AUG	-	-	-	-	-	-
3	1202			OWN	-	-	-	-	-	-
				PRE	-	-	-	-	-	-
F-A	V2 21202-002-H013		2K3-1202-002-02	ISI	-	-	-	-	-	-
F1.30G(2)	21202-002-H013		STRUT	AUG	-	-	-	-	-	-
3	1202			OWN	-	-	-	-	-	-
				PRE	-	-	-	-	-	-
F-A	V2 21202-002-H601		2K3-1202-002-02	ISI	-	-	-	-	-	-
F1.30G(2)	21202-002-H601		STRUT	AUG	-	-	-	-	-	-
3	1202			OWN	-	-	-	-	-	-
				PRE	-	-	-	-	-	-
F-A	V2 21202-004-H035		2K5-1202-004-01	ISI	-	-	-	-	-	-
F1.30G(2)	21202-004-H035		STRUT	AUG	-	-	-	-	-	-
3	1202			OWN	-	-	-	-	-	-
				PRE	-	-	-	-	-	-
F-A	V2 21202-004-H050		2K3-1202-004-05	ISI	-	-	-	-	-	-
F1.30G(2)	21202-004-H050		STRUT	AUG	-	-	-	-	-	-
3	1202			OWN	-	-	-	-	-	-
				PRE	-	-	-	-	-	-

Southern Nuclear Operating Company
3rd Interval
VOGTLE-2 ISI PLAN, VERSION 3.0

Category, Item No., Class	Summary No./ComplID/System	Scope / Method / Procedure	Dwg/ISO No. Comp. Desc. Code Case		Period 1		Period 2			Period 3	
					2VR13	2VR14	2VR14A	2VR15	2VR16	2VR17	2VR18
F-A	V2 21202-004-H054	ISI/VT/	2K3-1202-004-05	ISI	-	-	-	-	s	-	-
F1.30G(2)	21202-004-H054		STRUT	AUG	-	-	-	-	-	-	-
3	1202			OWN	-	-	-	-	-	-	-
				PRE	-	-	-	-	-	-	-
F-A	V2 21202-004-H073		2K5-1202-004-01	ISI	-	-	-	-	-	-	-
F1.30G(2)	21202-004-H073		STRUT	AUG	-	-	-	-	-	-	-
3	1202			OWN	-	-	-	-	-	-	-
				PRE	-	-	-	-	-	-	-
F-A	V2 21202-004-H075		2K5-1202-004-01	ISI	-	-	-	-	-	-	-
F1.30G(2)	21202-004-H075		STRUT	AUG	-	-	-	-	-	-	-
3	1202			OWN	-	-	-	-	-	-	-
				PRE	-	-	-	-	-	-	-
F-A	V2 21202-005-H022		2K2-1202-005-01	ISI	-	-	-	-	-	-	-
F1.30G(2)	21202-005-H022		STRUT	AUG	-	-	-	-	-	-	-
3	1202			OWN	-	-	-	-	-	-	-
				PRE	-	-	-	-	-	-	-
F-A	V2 21202-005-H024		2K2-1202-005-01	ISI	-	-	-	-	-	-	-
F1.30G(2)	21202-005-H024		STRUT	AUG	-	-	-	-	-	-	-
3	1202			OWN	-	-	-	-	-	-	-
				PRE	-	-	-	-	-	-	-
F-A	V2 21202-005-H054		2K2-1202-005-03	ISI	-	-	-	-	-	-	-
F1.30G(2)	21202-005-H054		STRUT	AUG	-	-	-	-	-	-	-
3	1202			OWN	-	-	-	-	-	-	-
				PRE	-	-	-	-	-	-	-
F-A	V2 21202-005-H056		2K2-1202-005-03	ISI	-	-	-	-	-	-	-
F1.30G(2)	21202-005-H056		STRUT	AUG	-	-	-	-	-	-	-
3	1202			OWN	-	-	-	-	-	-	-
				PRE	-	-	-	-	-	-	-
F-A	V2 21202-005-H061		2K7-1202-005-02	ISI	-	-	-	-	-	-	-
F1.30G(2)	21202-005-H061		STRUT	AUG	-	-	-	-	-	-	-
3	1202			OWN	-	-	-	-	-	-	-
				PRE	-	-	-	-	-	-	-
F-A	V2 21202-005-H602		2K2-1202-005-03	ISI	-	-	-	-	-	-	-
F1.30G(2)	21202-005-H602		STRUT	AUG	-	-	-	-	-	-	-
3	1202			OWN	-	-	-	-	-	-	-
				PRE	-	-	-	-	-	-	-
F-A	V2 21202-006-H049	ISI/VT/	2K3-1202-006-05	ISI	-	-	-	-	-	s	-
F1.30G(2)	21202-006-H049		STRUT	AUG	-	-	-	-	-	-	-
3	1202			OWN	-	-	-	-	-	-	-
				PRE	-	-	-	-	-	-	-

Southern Nuclear Operating Company
3rd Interval
VOGTLE-2 ISI PLAN, VERSION 3.0

Category, Item No., Class	Summary No./ComplID/System	Scope / Method / Procedure	Dwg/ISO No. Comp. Desc. Code Case		Period 1		Period 2			Period 3	
					2VR13	2VR14	2VR14A	2VR15	2VR16	2VR17	2VR18
F-A F1.30G(2) 3	V2 21202-084-H003 21202-084-H003 1202	ISI/VT/	2K3-1202-006-05 STRUT	ISI AUG OWN PRE	- - - -	- - - -	- - - -	s - - -	- - - -	- - - -	- - - -
F-A F1.30G(2) 3	V2 21202-085-H001 21202-085-H001 1202		2K3-1202-086-01 STRUT	ISI AUG OWN PRE	- - - -	- - - -	- - - -	- - - -	- - - -	- - - -	- - - -
F-A F1.30G(2) 3	V2 21202-085-H002 21202-085-H002 1202		2K3-1202-086-01 STRUT	ISI AUG OWN PRE	- - - -	- - - -	- - - -	- - - -	- - - -	- - - -	- - - -
F-A F1.30G(2) 3	V2 21202-088-H004 21202-088-H004 1202		2K5-1202-088-01 STRUT	ISI AUG OWN PRE	- - - -	- - - -	- - - -	- - - -	- - - -	- - - -	- - - -
F-A F1.30G(2) 3	V2 21202-088-H031 21202-088-H031 1202		2K3-1202-036-01 STRUT	ISI AUG OWN PRE	- - - -	- - - -	- - - -	- - - -	- - - -	- - - -	- - - -
F-A F1.30G(2) 3	V2 21202-088-H033 21202-088-H033 1202		2K3-1202-036-01 STRUT	ISI AUG OWN PRE	- - - -	- - - -	- - - -	- - - -	- - - -	- - - -	- - - -
F-A F1.30G(2) 3	V2 21202-088-H035 21202-088-H035 1202		2K3-1202-036-01 STRUT	ISI AUG OWN PRE	- - - -	- - - -	- - - -	- - - -	- - - -	- - - -	- - - -
F-A F1.30G(2) 3	V2 21202-088-H036 21202-088-H036 1202		2K3-1202-088-01 STRUT	ISI AUG OWN PRE	- - - -	- - - -	- - - -	- - - -	- - - -	- - - -	- - - -
F-A F1.30G(2) 3	V2 21202-088-H045 21202-088-H045 1202		2K5-1202-088-01 STRUT	ISI AUG OWN PRE	- - - -	- - - -	- - - -	- - - -	- - - -	- - - -	- - - -
F-A F1.30G(2) 3	V2 21202-098-H024 21202-098-H024 1202	ISI/VT/NMP-ES-024-203	2K3-1202-098-02 STRUT	ISI AUG OWN PRE	c - - -	- - - -	- - - -	- - - -	- - - -	- - - -	- - - -

Southern Nuclear Operating Company
3rd Interval
VOGTLE-2 ISI PLAN, VERSION 3.0

Category, Item No., Class	Summary No./ComplID/System	Scope / Method / Procedure	Dwg/ISO No. Comp. Desc. Code Case		Period 1		Period 2		Period 3	
					2VR13	2VR14	2VR14A	2VR15	2VR16	2VR17
F-A F1.30G(2) 3	V2 21202-099-H020 21202-099-H020 1202		2K3-1202-099-02 STRUT	ISI AUG OWN PRE	- - - -	- - - -	- - - -	- - - -	- - - -	- - - -
F-A F1.30G(2) 3	V2 21202-099-H603 21202-099-H603 1202		2K3-1202-099-01 STRUT	ISI AUG OWN PRE	- - - -	- - - -	- - - -	- - - -	- - - -	- - - -
F-A F1.30G(2) 3	V2 21202-104-H025 21202-104-H025 1202		2K3-1202-104-01 STRUT	ISI AUG OWN PRE	- - - -	- - - -	- - - -	- - - -	- - - -	- - - -
F-A F1.30G(2) 3	V2 21202-104-H034 21202-104-H034 1202		2K3-1202-104-01 STRUT	ISI AUG OWN PRE	- - - -	- - - -	- - - -	- - - -	- - - -	- - - -
F-A F1.30G(2) 3	V2 21202-104-H040 21202-104-H040 1202		2K3-1202-104-03 STRUT	ISI AUG OWN PRE	- - - -	- - - -	- - - -	- - - -	- - - -	- - - -
F-A F1.30G(2) 3	V2 21202-104-H049 21202-104-H049 1202		2K3-1202-104-03 STRUT	ISI AUG OWN PRE	- - - -	- - - -	- - - -	- - - -	- - - -	- - - -
F-A F1.30G(2) 3	V2 21202-104-H606 21202-104-H606 1202		2K2-1202-104-02 STRUT	ISI AUG OWN PRE	- - - -	- - - -	- - - -	- - - -	- - - -	- - - -
F-A F1.30G(2) 3	V2 21202-134-H003 21202-134-H003 1202		2K3-1202-134-02 STRUT	ISI AUG OWN PRE	- - - -	- - - -	- - - -	- - - -	- - - -	- - - -
F-A F1.30G(2) 3	V2 21202-134-H019 21202-134-H019 1202		2K3-1202-134-02 STRUT	ISI AUG OWN PRE	- - - -	- - - -	- - - -	- - - -	- - - -	- - - -
F-A F1.30G(2) 3	V2 21202-151-H027 21202-151-H027 1202		2K3-1202-151-04 STRUT	ISI AUG OWN PRE	- - - -	- - - -	- - - -	- - - -	- - - -	- - - -

Southern Nuclear Operating Company
3rd Interval
VOGTLE-2 ISI PLAN, VERSION 3.0

Category, Item No., Class	Summary No./Compld/System	Scope / Method / Procedure	Dwg/ISO No. Comp. Desc. Code Case		Period 1		Period 2			Period 3	
					2VR13	2VR14	2VR14A	2VR15	2VR16	2VR17	2VR18
F-A	V2 21202-181-H004		2K5-1202-181-01	ISI	-	-	-	-	-	-	-
F1.30G(2)	21202-181-H004		STRUT	AUG	-	-	-	-	-	-	-
3	1202			OWN	-	-	-	-	-	-	-
				PRE	-	-	-	-	-	-	-
F-A	V2 21202-181-H023	ISI/VT/	2K5-1202-035-01	ISI	-	-	-	-	-	s	-
F1.30G(2)	21202-181-H023		STRUT	AUG	-	-	-	-	-	-	-
3	1202			OWN	-	-	-	-	-	-	-
				PRE	-	-	-	-	-	-	-
F-A	V2 21202-181-H025		2K5-1202-035-01	ISI	-	-	-	-	-	-	-
F1.30G(2)	21202-181-H025		STRUT	AUG	-	-	-	-	-	-	-
3	1202			OWN	-	-	-	-	-	-	-
				PRE	-	-	-	-	-	-	-
F-A	V2 21202-181-H029		2K3-1202-181-01	ISI	-	-	-	-	-	-	-
F1.30G(2)	21202-181-H029		STRUT	AUG	-	-	-	-	-	-	-
3	1202			OWN	-	-	-	-	-	-	-
				PRE	-	-	-	-	-	-	-
F-A	V2 21202-181-H030		2K3-1202-181-01	ISI	-	-	-	-	-	-	-
F1.30G(2)	21202-181-H030		STRUT	AUG	-	-	-	-	-	-	-
3	1202			OWN	-	-	-	-	-	-	-
				PRE	-	-	-	-	-	-	-
F-A	V2 21202-181-H033		2K5-1202-181-01	ISI	-	-	-	-	-	-	-
F1.30G(2)	21202-181-H033		STRUT	AUG	-	-	-	-	-	-	-
3	1202			OWN	-	-	-	-	-	-	-
				PRE	-	-	-	-	-	-	-
F-A	V2 21202-181-H039		2K5-1202-181-01	ISI	-	-	-	-	-	-	-
F1.30G(2)	21202-181-H039		STRUT	AUG	-	-	-	-	-	-	-
3	1202			OWN	-	-	-	-	-	-	-
				PRE	-	-	-	-	-	-	-
F-A	V2 21202-181-H603		2K3-1202-181-01	ISI	-	-	-	-	-	-	-
F1.30G(2)	21202-181-H603		STRUT	AUG	-	-	-	-	-	-	-
3	1202			OWN	-	-	-	-	-	-	-
				PRE	-	-	-	-	-	-	-
F-A	V2 21202-187-H005		2K3-1202-187-03	ISI	-	-	-	-	-	-	-
F1.30G(2)	21202-187-H005		STRUT	AUG	-	-	-	-	-	-	-
3	1202			OWN	-	-	-	-	-	-	-
				PRE	-	-	-	-	-	-	-
F-A	V2 21202-187-H008		2K3-1202-187-03	ISI	-	-	-	-	-	-	-
F1.30G(2)	21202-187-H008		STRUT	AUG	-	-	-	-	-	-	-
3	1202			OWN	-	-	-	-	-	-	-
				PRE	-	-	-	-	-	-	-

**Southern Nuclear Operating Company
3rd Interval
VOGTLE-2 ISI PLAN, VERSION 3.0**

Category, Item No., Class	Summary No./ComplID/System	Scope / Method / Procedure	Dwg/ISO No. Comp. Desc. Code Case		Period 1		Period 2		Period 3	
					2VR13	2VR14	2VR14A	2VR15	2VR16	2VR17
F-A	V2 21202-194-H001		2K3-1202-194-01	ISI	-	-	-	-	-	-
F1.30G(2)	21202-194-H001		STRUT	AUG	-	-	-	-	-	-
3	1202			OWN	-	-	-	-	-	-
				PRE	-	-	-	-	-	-
F-A	V2 21202-390-H001		2K3-1202-037-01	ISI	-	-	-	-	-	-
F1.30G(2)	21202-390-H001		STRUT	AUG	-	-	-	-	-	-
3	1202			OWN	-	-	-	-	-	-
				PRE	-	-	-	-	-	-
F-A	V2 21202-390-H010		2K3-1202-004-05	ISI	-	-	-	-	-	-
F1.30G(2)	21202-390-H010		STRUT	AUG	-	-	-	-	-	-
3	1202			OWN	-	-	-	-	-	-
				PRE	-	-	-	-	-	-
F-A	V2 21202-390-H012		2K3-1202-004-05	ISI	-	-	-	-	-	-
F1.30G(2)	21202-390-H012		STRUT	AUG	-	-	-	-	-	-
3	1202			OWN	-	-	-	-	-	-
				PRE	-	-	-	-	-	-
F-A	V2 21202-487-H001		2K5-1202-181-01	ISI	-	-	-	-	-	-
F1.30G(2)	21202-487-H001		STRUT	AUG	-	-	-	-	-	-
3	1202			OWN	-	-	-	-	-	-
				PRE	-	-	-	-	-	-
F-A	V2 21202-488-H002		2K5-1202-088-01	ISI	-	-	-	-	-	-
F1.30G(2)	21202-488-H002		STRUT	AUG	-	-	-	-	-	-
3	1202			OWN	-	-	-	-	-	-
				PRE	-	-	-	-	-	-
F-A	V2 21202-509-H602		2K5-1202-512-01	ISI	-	-	-	-	-	-
F1.30G(2)	21202-509-H602		STRUT	AUG	-	-	-	-	-	-
3	1202			OWN	-	-	-	-	-	-
				PRE	-	-	-	-	-	-
F-A	V2 21202-509-H603		2K5-1202-512-01	ISI	-	-	-	-	-	-
F1.30G(2)	21202-509-H603		STRUT	AUG	-	-	-	-	-	-
3	1202			OWN	-	-	-	-	-	-
				PRE	-	-	-	-	-	-
F-A	V2 21202-511-H602		2K5-1202-512-01	ISI	-	-	-	-	-	-
F1.30G(2)	21202-511-H602		STRUT	AUG	-	-	-	-	-	-
3	1202			OWN	-	-	-	-	-	-
				PRE	-	-	-	-	-	-
F-A	V2 21203-021-H001	ISI/VT/	2K3-1203-021-01	ISI	-	-	-	-	s	-
F1.30G(2)	21203-021-H001		STRUT	AUG	-	-	-	-	-	-
3	1203			OWN	-	-	-	-	-	-
				PRE	-	-	-	-	-	-

**Southern Nuclear Operating Company
3rd Interval
VOGTLE-2 ISI PLAN, VERSION 3.0**

Category, Item No., Class	Summary No./ComplD/System	Scope / Method / Procedure	Dwg/ISO No. Comp. Desc. Code Case		Period 1		Period 2			Period 3	
					2VR13	2VR14	2VR14A	2VR15	2VR16	2VR17	2VR18
F-A	V2 21203-021-H002		2K3-1203-021-01	ISI	-	-	-	-	-	-	-
F1.30G(2)	21203-021-H002		STRUT	AUG	-	-	-	-	-	-	-
3	1203			OWN	-	-	-	-	-	-	-
				PRE	-	-	-	-	-	-	-
F-A	V2 21203-021-H004		2K3-1203-021-02	ISI	-	-	-	-	-	-	-
F1.30G(2)	21203-021-H004		STRUT	AUG	-	-	-	-	-	-	-
3	1203			OWN	-	-	-	-	-	-	-
				PRE	-	-	-	-	-	-	-
F-A	V2 21203-021-H008		2K3-1203-021-02	ISI	-	-	-	-	-	-	-
F1.30G(2)	21203-021-H008		STRUT	AUG	-	-	-	-	-	-	-
3	1203			OWN	-	-	-	-	-	-	-
				PRE	-	-	-	-	-	-	-
F-A	V2 21203-021-H010		2K3-1203-021-02	ISI	-	-	-	-	-	-	-
F1.30G(2)	21203-021-H010		STRUT	AUG	-	-	-	-	-	-	-
3	1203			OWN	-	-	-	-	-	-	-
				PRE	-	-	-	-	-	-	-
F-A	V2 21203-021-H014		2K3-1203-021-03	ISI	-	-	-	-	-	-	-
F1.30G(2)	21203-021-H014		STRUT	AUG	-	-	-	-	-	-	-
3	1203			OWN	-	-	-	-	-	-	-
				PRE	-	-	-	-	-	-	-
F-A	V2 21203-026-H001		2K3-1203-026-01	ISI	-	-	-	-	-	-	-
F1.30G(2)	21203-026-H001		STRUT	AUG	-	-	-	-	-	-	-
3	1203			OWN	-	-	-	-	-	-	-
				PRE	-	-	-	-	-	-	-
F-A	V2 21203-026-H007A		2K3-1203-026-01	ISI	-	-	-	-	-	-	-
F1.30G(2)	21203-026-H007E		STRUT	AUG	-	-	-	-	-	-	-
3	1203			OWN	-	-	-	-	-	-	-
				PRE	-	-	-	-	-	-	-
F-A	V2 21203-026-H007B		2K3-1203-026-01	ISI	-	-	-	-	-	-	-
F1.30G(2)	21203-026-H007W		STRUT	AUG	-	-	-	-	-	-	-
3	1203			OWN	-	-	-	-	-	-	-
				PRE	-	-	-	-	-	-	-
F-A	V2 21203-026-H008		2K3-1203-026-01	ISI	-	-	-	-	-	-	-
F1.30G(2)	21203-026-H008		STRUT	AUG	-	-	-	-	-	-	-
3	1203			OWN	-	-	-	-	-	-	-
				PRE	-	-	-	-	-	-	-
F-A	V2 21203-030-H003		2K3-1203-026-01	ISI	-	-	-	-	-	-	-
F1.30G(2)	21203-030-H003		STRUT	AUG	-	-	-	-	-	-	-
3	1203			OWN	-	-	-	-	-	-	-
				PRE	-	-	-	-	-	-	-

**Southern Nuclear Operating Company
3rd Interval
VOGTLE-2 ISI PLAN, VERSION 3.0**

Category, Item No., Class	Summary No./ComplD/System	Scope / Method / Procedure	Dwg/ISO No. Comp. Desc. Code Case		Period 1		Period 2			Period 3	
					2VR13	2VR14	2VR14A	2VR15	2VR16	2VR17	2VR18
F-A F1.30G(2) 3	V2 21203-034-H002 21203-034-H002 1203		2K3-1203-034-01 STRUT	ISI AUG OWN PRE	-	-	-	-	-	-	-
F-A F1.30G(2) 3	V2 21203-034-H003 21203-034-H003 1203		2K3-1203-034-01 STRUT	ISI AUG OWN PRE	-	-	-	-	-	-	-
F-A F1.30G(2) 3	V2 21203-034-H005 21203-034-H005 1203		2K3-1203-034-01 STRUT	ISI AUG OWN PRE	-	-	-	-	-	-	-
F-A F1.30G(2) 3	V2 21203-034-H007 21203-034-H007 1203	ISI/VT/	2K3-1203-034-01 STRUT	ISI AUG OWN PRE	-	-	-	s	-	-	-
F-A F1.30G(2) 3	V2 21203-034-H008 21203-034-H008 1203		2K3-1203-034-01 STRUT	ISI AUG OWN PRE	-	-	-	-	-	-	-
F-A F1.30G(2) 3	V2 21203-034-H012 21203-034-H012 1203		2K3-1203-034-02 STRUT	ISI AUG OWN PRE	-	-	-	-	-	-	-
F-A F1.30G(2) 3	V2 21203-042-H001 21203-042-H001 1203		2K3-1203-042-01 STRUT	ISI AUG OWN PRE	-	-	-	-	-	-	-
F-A F1.30G(2) 3	V2 21203-042-H002 21203-042-H002 1203		2K3-1203-042-01 STRUT	ISI AUG OWN PRE	-	-	-	-	-	-	-
F-A F1.30G(2) 3	V2 21203-042-H005 21203-042-H005 1203		2K3-1203-042-02 STRUT	ISI AUG OWN PRE	-	-	-	-	-	-	-
F-A F1.30G(2) 3	V2 21203-042-H006 21203-042-H006 1203		2K3-1203-042-02 STRUT	ISI AUG OWN PRE	-	-	-	-	-	-	-

Southern Nuclear Operating Company
3rd Interval
VOGTLE-2 ISI PLAN, VERSION 3.0

Category, Item No., Class	Summary No./CompID/System	Scope / Method / Procedure	Dwg/ISO No. Comp. Desc. Code Case		Period 1		Period 2		Period 3	
					2VR13	2VR14	2VR14A	2VR15	2VR16	2VR17
F-A	V2 21203-042-H007		2K3-1203-042-02	ISI	-	-	-	-	-	-
F1.30G(2)	21203-042-H007		STRUT	AUG	-	-	-	-	-	-
3	1203			OWN	-	-	-	-	-	-
				PRE	-	-	-	-	-	-
F-A	V2 21203-042-H010		2K3-1203-042-03	ISI	-	-	-	-	-	-
F1.30G(2)	21203-042-H010		STRUT	AUG	-	-	-	-	-	-
3	1203			OWN	-	-	-	-	-	-
				PRE	-	-	-	-	-	-
F-A	V2 21203-042-H011		2K3-1203-042-03	ISI	-	-	-	-	-	-
F1.30G(2)	21203-042-H011		STRUT	AUG	-	-	-	-	-	-
3	1203			OWN	-	-	-	-	-	-
				PRE	-	-	-	-	-	-
F-A	V2 21203-042-H017		2K3-1203-042-04	ISI	-	-	-	-	-	-
F1.30G(2)	21203-042-H017		STRUT	AUG	-	-	-	-	-	-
3	1203			OWN	-	-	-	-	-	-
				PRE	-	-	-	-	-	-
F-A	V2 21203-042-H018		2K3-1203-042-04	ISI	-	-	-	-	-	-
F1.30G(2)	21203-042-H018		STRUT	AUG	-	-	-	-	-	-
3	1203			OWN	-	-	-	-	-	-
				PRE	-	-	-	-	-	-
F-A	V2 21203-055-H002		2K3-1203-055-01	ISI	-	-	-	-	-	-
F1.30G(2)	21203-055-H002		STRUT	AUG	-	-	-	-	-	-
3	1203			OWN	-	-	-	-	-	-
				PRE	-	-	-	-	-	-
F-A	V2 21203-055-H003	ISI/VT/	2K3-1203-055-01	ISI	-	-	-	-	s	-
F1.30G(2)	21203-055-H003		STRUT	AUG	-	-	-	-	-	-
3	1203			OWN	-	-	-	-	-	-
				PRE	-	-	-	-	-	-
F-A	V2 21203-055-H013		2K3-1203-055-02	ISI	-	-	-	-	-	-
F1.30G(2)	21203-055-H013		STRUT	AUG	-	-	-	-	-	-
3	1203			OWN	-	-	-	-	-	-
				PRE	-	-	-	-	-	-
F-A	V2 21203-055-H016		2K3-1203-055-02	ISI	-	-	-	-	-	-
F1.30G(2)	21203-055-H016		STRUT	AUG	-	-	-	-	-	-
3	1203			OWN	-	-	-	-	-	-
				PRE	-	-	-	-	-	-
F-A	V2 21203-055-H019		2K3-1203-055-02	ISI	-	-	-	-	-	-
F1.30G(2)	21203-055-H019		STRUT	AUG	-	-	-	-	-	-
3	1203			OWN	-	-	-	-	-	-
				PRE	-	-	-	-	-	-

Southern Nuclear Operating Company
3rd Interval
VOGTLE-2 ISI PLAN, VERSION 3.0

Category, Item No., Class	Summary No./ComplD/System	Scope / Method / Procedure	Dwg/ISO No. Comp. Desc. Code Case		Period 1		Period 2			Period 3		
					2VR13	2VR14	2VR14A	2VR15	2VR16	2VR17	2VR18	
F-A F1.30G(2) 3	V2 21203-055-H021 21203-055-H021 1203		2K3-1203-055-02 STRUT	ISI AUG OWN PRE	-	-	-	-	-	-	-	-
F-A F1.30G(2) 3	V2 21203-055-H602 21203-055-H602 1203		2K3-1203-055-01 STRUT	ISI AUG OWN PRE	-	-	-	-	-	-	-	-
F-A F1.30G(2) 3	V2 21203-063-H020 21203-063-H020 1203		2K3-1203-063-01 STRUT	ISI AUG OWN PRE	-	-	-	-	-	-	-	-
F-A F1.30G(2) 3	V2 21203-091-H002 21203-091-H002 1203		2K3-1203-055-01 STRUT	ISI AUG OWN PRE	-	-	-	-	-	-	-	-
F-A F1.30G(2) 3	V2 21203-091-H007 21203-091-H007 1203		2K7-1203-091-01 STRUT	ISI AUG OWN PRE	-	-	-	-	-	-	-	-
F-A F1.30G(2) 3	V2 21203-093-H005 21203-093-H005 1203	ISI/VT/NMP-ES-024-203	2K3-1203-042-02 STRUT	ISI AUG OWN PRE	c	-	-	-	-	-	-	-
F-A F1.30G(2) 3	V2 21203-093-H007 21203-093-H007 1203		2K7-1203-093-01 STRUT	ISI AUG OWN PRE	-	-	-	-	-	-	-	-
F-A F1.30G(2) 3	V2 21203-093-H009 21203-093-H009 1203		2K7-1203-093-01 STRUT	ISI AUG OWN PRE	-	-	-	-	-	-	-	-
F-A F1.30G(2) 3	V2 21213-001-H008 21213-001-H008 1213		2K3-1213-001-01 STRUT	ISI AUG OWN PRE	-	-	-	-	-	-	-	-
F-A F1.30G(2) 3	V2 21301-010-H039 21301-010-H039 1301		2K5-1301-010-01 RIGID STRUT	ISI AUG OWN PRE	-	-	-	-	-	-	-	-

Southern Nuclear Operating Company
3rd Interval
VOGTLE-2 ISI PLAN, VERSION 3.0

Category, Item No., Class	Summary No./ComplD/System	Scope / Method / Procedure	Dwg/ISO No. Comp. Desc. Code Case		Period 1		Period 2			Period 3	
					2VR13	2VR14	2VR14A	2VR15	2VR16	2VR17	2VR18
F-A	V2 21302-007-H002		2K5-1302-007-01	ISI	-	-	-	-	-	-	-
F1.30G(2)	21302-007-H002		STRUT	AUG	-	-	-	-	-	-	-
3	1302			OWN	-	-	-	-	-	-	-
				PRE	-	-	-	-	-	-	-
F-A	V2 21302-007-H005		2K5-1302-007-01	ISI	-	-	-	-	-	-	-
F1.30G(2)	21302-007-H005		STRUT	AUG	-	-	-	-	-	-	-
3	1302			OWN	-	-	-	-	-	-	-
				PRE	-	-	-	-	-	-	-
F-A	V2 21302-016-H002	ISI/VT/	2K5-1302-016-01	ISI	-	-	-	s	-	-	-
F1.30G(2)	21302-016-H002		STRUT	AUG	-	-	-	-	-	-	-
3	1302			OWN	-	-	-	-	-	-	-
				PRE	-	-	-	-	-	-	-
F-A	V2 21302-017-H001		2K5-1302-017-01	ISI	-	-	-	-	-	-	-
F1.30G(2)	21302-017-H001		STRUT	AUG	-	-	-	-	-	-	-
3	1302			OWN	-	-	-	-	-	-	-
				PRE	-	-	-	-	-	-	-
F-A	V2 21302-017-H002		2K5-1302-017-01	ISI	-	-	-	-	-	-	-
F1.30G(2)	21302-017-H002		STRUT	AUG	-	-	-	-	-	-	-
3	1302			OWN	-	-	-	-	-	-	-
				PRE	-	-	-	-	-	-	-
F-A	V2 21302-017-H601		2K5-1302-017-01	ISI	-	-	-	-	-	-	-
F1.30G(2)	21302-017-H601		STRUT	AUG	-	-	-	-	-	-	-
3	1302			OWN	-	-	-	-	-	-	-
				PRE	-	-	-	-	-	-	-
F-A	V2 21302-017-H602		2K5-1302-017-01	ISI	-	-	-	-	-	-	-
F1.30G(2)	21302-017-H602		STRUT	AUG	-	-	-	-	-	-	-
3	1302			OWN	-	-	-	-	-	-	-
				PRE	-	-	-	-	-	-	-
F-A	V2 21302-020-H024		2K3-1302-020-01	ISI	-	-	-	-	-	-	-
F1.30G(2)	21302-020-H024		STRUT	AUG	-	-	-	-	-	-	-
3	1302			OWN	-	-	-	-	-	-	-
				PRE	-	-	-	-	-	-	-
F-A	V2 21302-024-H003		2K5-1302-024-01	ISI	-	-	-	-	-	-	-
F1.30G(2)	21302-024-H003		STRUT	AUG	-	-	-	-	-	-	-
3	1302			OWN	-	-	-	-	-	-	-
				PRE	-	-	-	-	-	-	-
F-A	V2 21302-024-H004		2K5-1302-024-01	ISI	-	-	-	-	-	-	-
F1.30G(2)	21302-024-H004		STRUT	AUG	-	-	-	-	-	-	-
3	1302			OWN	-	-	-	-	-	-	-
				PRE	-	-	-	-	-	-	-

Southern Nuclear Operating Company
3rd Interval
VOGTLE-2 ISI PLAN, VERSION 3.0

Category, Item No., Class	Summary No./ComplD/System	Scope / Method / Procedure	Dwg/ISO No. Comp. Desc. Code Case		Period 1		Period 2			Period 3	
					2VR13	2VR14	2VR14A	2VR15	2VR16	2VR17	2VR18
F-A	V2 21302-025-H002		2K5-1302-025-01	ISI	-	-	-	-	-	-	-
F1.30G(2)	21302-025-H002		STRUT	AUG	-	-	-	-	-	-	-
3	1302			OWN	-	-	-	-	-	-	-
				PRE	-	-	-	-	-	-	-
F-A	V2 21302-025-H005		2K5-1302-025-01	ISI	-	-	-	-	-	-	-
F1.30G(2)	21302-025-H005		STRUT	AUG	-	-	-	-	-	-	-
3	1302			OWN	-	-	-	-	-	-	-
				PRE	-	-	-	-	-	-	-
F-A	V2 21302-027-H008	ISI/VT/	2K5-1302-027-01	ISI	-	-	-	s	-	-	-
F1.30G(2)	21302-027-H008		STRUT	AUG	-	-	-	-	-	-	-
3	1302			OWN	-	-	-	-	-	-	-
				PRE	-	-	-	-	-	-	-
F-A	V2 21302-038-H001		2K5-1305-038-02	ISI	-	-	-	-	-	-	-
F1.30G(2)	21302-038-H001		STRUT	AUG	-	-	-	-	-	-	-
3	1302			OWN	-	-	-	-	-	-	-
				PRE	-	-	-	-	-	-	-
F-A	V2 21302-040-H002		2K5-1302-015-01	ISI	-	-	-	-	-	-	-
F1.30G(2)	21302-040-H002		STRUT	AUG	-	-	-	-	-	-	-
3	1302			OWN	-	-	-	-	-	-	-
				PRE	-	-	-	-	-	-	-
F-A	V2 21302-051-H001		2K5-1302-048-01	ISI	-	-	-	-	-	-	-
F1.30G(2)	21302-051-H001		STRUT	AUG	-	-	-	-	-	-	-
3	1302			OWN	-	-	-	-	-	-	-
				PRE	-	-	-	-	-	-	-
F-A	V2 21302-132-H003		2K5-1302-007-01	ISI	-	-	-	-	-	-	-
F1.30G(2)	21302-132-H003		STRUT	AUG	-	-	-	-	-	-	-
3	1302			OWN	-	-	-	-	-	-	-
				PRE	-	-	-	-	-	-	-
F-A	V2 21592-007-H013		2K2-1592-007-01	ISI	-	-	-	-	-	-	-
F1.30G(2)	21592-007-H013		STRUT	AUG	-	-	-	-	-	-	-
3	1592			OWN	-	-	-	-	-	-	-
				PRE	-	-	-	-	-	-	-
F-A	V2 21592-008-H027	ISI/VT/	2K2-1592-008-02	ISI	-	-	-	-	-	s	-
F1.30G(2)	21592-008-H027		STRUT	AUG	-	-	-	-	-	-	-
3	1592			OWN	-	-	-	-	-	-	-
				PRE	-	-	-	-	-	-	-
F-A	V2 21592-054-H073		2K3-1592-054-03	ISI	-	-	-	-	-	-	-
F1.30G(2)	21592-054-H073		STRUT	AUG	-	-	-	-	-	-	-
3	1592			OWN	-	-	-	-	-	-	-
				PRE	-	-	-	-	-	-	-

**Southern Nuclear Operating Company
3rd Interval
VOGTLE-2 ISI PLAN, VERSION 3.0**

Category, Item No., Class	Summary No./ComplD/System	Scope / Method / Procedure	Dwg/ISO No. Comp. Desc. Code Case		Period 1		Period 2			Period 3	
					2VR13	2VR14	2VR14A	2VR15	2VR16	2VR17	2VR18
F-A F1.30H(2) 3	V2 21202-002-H014 21202-002-H014 1202	ISI/VT/	2K3-1202-002-02 VAR SPRING	ISI AUG OWN PRE	-	-	-	-	s	-	-
F-A F1.30H(2) 3	V2 21202-004-H022 21202-004-H022 1202		2K5-1202-004-01 VAR SPRING	ISI AUG OWN PRE	-	-	-	-	-	-	-
F-A F1.30H(2) 3	V2 21202-004-H024 21202-004-H024 1202		2K5-1202-004-01 VAR SPRING	ISI AUG OWN PRE	-	-	-	-	-	-	-
F-A F1.30H(2) 3	V2 21202-004-H026 21202-004-H026 1202		2K5-1202-004-01 VAR SPRING	ISI AUG OWN PRE	-	-	-	-	-	-	-
F-A F1.30H(2) 3	V2 21202-004-H042 21202-004-H042 1202		2K5-1202-004-02 VAR SPRING	ISI AUG OWN PRE	-	-	-	-	-	-	-
F-A F1.30H(2) 3	V2 21202-004-H049 21202-004-H049 1202		2K3-1202-004-05 VAR SPRING	ISI AUG OWN PRE	-	-	-	-	-	-	-
F-A F1.30H(2) 3	V2 21202-004-H051 21202-004-H051 1202		2K3-1202-004-05 VAR SPRING	ISI AUG OWN PRE	-	-	-	-	-	-	-
F-A F1.30H(2) 3	V2 21202-004-H055 21202-004-H055 1202		2K5-1202-004-02 VAR SPRING	ISI AUG OWN PRE	-	-	-	-	-	-	-
F-A F1.30H(2) 3	V2 21202-004-H058 21202-004-H058 1202		2K5-1202-004-02 VAR SPRING	ISI AUG OWN PRE	-	-	-	-	-	-	-
F-A F1.30H(2) 3	V2 21202-004-H059 21202-004-H059 1202		2K5-1202-004-02 VAR SPRING	ISI AUG OWN PRE	-	-	-	-	-	-	-

Southern Nuclear Operating Company
3rd Interval
VOGTLE-2 ISI PLAN, VERSION 3.0

Category, Item No., Class	Summary No./ComplID/System	Scope / Method / Procedure	Dwg/ISO No. Comp. Desc. Code Case		Period 1		Period 2			Period 3	
					2VR13	2VR14	2VR14A	2VR15	2VR16	2VR17	2VR18
F-A	V2 21202-004-H067		2K5-1202-004-01	ISI	-	-	-	-	-	-	-
F1.30H(2)	21202-004-H067		VAR SPRING	AUG	-	-	-	-	-	-	-
3	1202			OWN	-	-	-	-	-	-	-
				PRE	-	-	-	-	-	-	-
F-A	V2 21202-004-H070		2K5-1202-004-01	ISI	-	-	-	-	-	-	-
F1.30H(2)	21202-004-H070		VAR SPRING	AUG	-	-	-	-	-	-	-
3	1202			OWN	-	-	-	-	-	-	-
				PRE	-	-	-	-	-	-	-
F-A	V2 21202-004-H076		2K5-1202-004-01	ISI	-	-	-	-	-	-	-
F1.30H(2)	21202-004-H076		VAR SPRING	AUG	-	-	-	-	-	-	-
3	1202			OWN	-	-	-	-	-	-	-
				PRE	-	-	-	-	-	-	-
F-A	V2 21202-004-H077		2K5-1202-004-01	ISI	-	-	-	-	-	-	-
F1.30H(2)	21202-004-H077		VAR SPRING	AUG	-	-	-	-	-	-	-
3	1202			OWN	-	-	-	-	-	-	-
				PRE	-	-	-	-	-	-	-
F-A	V2 21202-005-H049		2K2-1202-005-03	ISI	-	-	-	-	-	-	-
F1.30H(2)	21202-005-H049		VAR SPRING	AUG	-	-	-	-	-	-	-
3	1202			OWN	-	-	-	-	-	-	-
				PRE	-	-	-	-	-	-	-
F-A	V2 21202-006-H028	ISI/VT/	2K5-1202-006-01	ISI	-	-	-	s	-	-	-
F1.30H(2)	21202-006-H028		VAR SPRING	AUG	-	-	-	-	-	-	-
3	1202			OWN	-	-	-	-	-	-	-
				PRE	-	-	-	-	-	-	-
F-A	V2 21202-006-H040		2K5-1202-006-01	ISI	-	-	-	-	-	-	-
F1.30H(2)	21202-006-H040		VAR SPRING	AUG	-	-	-	-	-	-	-
3	1202			OWN	-	-	-	-	-	-	-
				PRE	-	-	-	-	-	-	-
F-A	V2 21202-006-H042		2K5-1202-006-01	ISI	-	-	-	-	-	-	-
F1.30H(2)	21202-006-H042		VAR SPRING	AUG	-	-	-	-	-	-	-
3	1202			OWN	-	-	-	-	-	-	-
				PRE	-	-	-	-	-	-	-
F-A	V2 21202-006-H047		2K5-1202-006-02	ISI	-	-	-	-	-	-	-
F1.30H(2)	21202-006-H047		VAR SPRING	AUG	-	-	-	-	-	-	-
3	1202			OWN	-	-	-	-	-	-	-
				PRE	-	-	-	-	-	-	-
F-A	V2 21202-006-H051		2K5-1202-006-02	ISI	-	-	-	-	-	-	-
F1.30H(2)	21202-006-H051		VAR SPRING	AUG	-	-	-	-	-	-	-
3	1202			OWN	-	-	-	-	-	-	-
				PRE	-	-	-	-	-	-	-

Southern Nuclear Operating Company
3rd Interval
VOGTLE-2 ISI PLAN, VERSION 3.0

Category, Item No., Class	Summary No./CompID/System	Scope / Method / Procedure	Dwg/ISO No. Comp. Desc. Code Case		Period 1		Period 2			Period 3	
					2VR13	2VR14	2VR14A	2VR15	2VR16	2VR17	2VR18
F-A F1.30H(2) 3	V2 21202-006-H053 21202-006-H053 1202		2K5-1202-006-02 VAR SPRING	ISI AUG OWN PRE	-	-	-	-	-	-	-
F-A F1.30H(2) 3	V2 21202-006-H054 21202-006-H054 1202	ISI/VT/	2K5-1202-006-02 VAR SPRING	ISI AUG OWN PRE	-	-	-	-	-	5	-
F-A F1.30H(2) 3	V2 21202-006-H064 21202-006-H064 1202		2K5-1202-006-01 VAR SPRING	ISI AUG OWN PRE	-	-	-	-	-	-	-
F-A F1.30H(2) 3	V2 21202-007-H009 21202-007-H009 1202		2K5-1202-181-01 VAR SPRING	ISI AUG OWN PRE	-	-	-	-	-	-	-
F-A F1.30H(2) 3	V2 21202-008-H008 21202-008-H008 1202		2K5-1202-181-01 VAR SPRING	ISI AUG OWN PRE	-	-	-	-	-	-	-
F-A F1.30H(2) 3	V2 21202-009-H008 21202-009-H008 1202		2K5-1202-181-01 VAR SPRING	ISI AUG OWN PRE	-	-	-	-	-	-	-
F-A F1.30H(2) 3	V2 21202-010-H008 21202-010-H008 1202		2K5-1202-181-01 VAR SPRING	ISI AUG OWN PRE	-	-	-	-	-	-	-
F-A F1.30H(2) 3	V2 21202-011-H008 21202-011-H008 1202		2K5-1202-011-01 VAR SPRING	ISI AUG OWN PRE	-	-	-	-	-	-	-
F-A F1.30H(2) 3	V2 21202-012-H008 21202-012-H008 1202		2K5-1202-012-01 VAR SPRING	ISI AUG OWN PRE	-	-	-	-	-	-	-
F-A F1.30H(2) 3	V2 21202-013-H008 21202-013-H008 1202		2K5-1202-013-01 VAR SPRING	ISI AUG OWN PRE	-	-	-	-	-	-	-

Southern Nuclear Operating Company
3rd Interval
VOGTLE-2 ISI PLAN, VERSION 3.0

Category, Item No., Class	Summary No./ComplD/System	Scope / Method / Procedure	Dwg/ISO No. Comp. Desc. Code Case		Period 1		Period 2		Period 3	
					2VR13	2VR14	2VR14A	2VR15	2VR16	2VR17
F-A	V2 21202-023-H004		2K5-1202-023-01	ISI	-	-	-	-	-	-
F1.30H(2)	21202-023-H004		VAR SPRING	AUG	-	-	-	-	-	-
3	1202			OWN	-	-	-	-	-	-
				PRE	-	-	-	-	-	-
F-A	V2 21202-031-H004		2K5-1202-031-01	ISI	-	-	-	-	-	-
F1.30H(2)	21202-031-H004		VAR SPRING	AUG	-	-	-	-	-	-
3	1202			OWN	-	-	-	-	-	-
				PRE	-	-	-	-	-	-
F-A	V2 21202-032-H004		2K5-1202-032-01	ISI	-	-	-	-	-	-
F1.30H(2)	21202-032-H004		VAR SPRING	AUG	-	-	-	-	-	-
3	1202			OWN	-	-	-	-	-	-
				PRE	-	-	-	-	-	-
F-A	V2 21202-033-H004		2K5-1202-033-01	ISI	-	-	-	-	-	-
F1.30H(2)	21202-033-H004		VAR SPRING	AUG	-	-	-	-	-	-
3	1202			OWN	-	-	-	-	-	-
				PRE	-	-	-	-	-	-
F-A	V2 21202-034-H004		2K5-1202-034-01	ISI	-	-	-	-	-	-
F1.30H(2)	21202-034-H004		VAR SPRING	AUG	-	-	-	-	-	-
3	1202			OWN	-	-	-	-	-	-
				PRE	-	-	-	-	-	-
F-A	V2 21202-084-H002		2K3-1202-006-05	ISI	-	-	-	-	-	-
F1.30H(2)	21202-084-H002		VAR SPRING	AUG	-	-	-	-	-	-
3	1202			OWN	-	-	-	-	-	-
				PRE	-	-	-	-	-	-
F-A	V2 21202-084-H004		2K3-1202-006-05	ISI	-	-	-	-	-	-
F1.30H(2)	21202-084-H004		VAR SPRING	AUG	-	-	-	-	-	-
3	1202			OWN	-	-	-	-	-	-
				PRE	-	-	-	-	-	-
F-A	V2 21202-084-H005		2K3-1202-086-01	ISI	-	-	-	-	-	-
F1.30H(2)	21202-084-H005		VAR SPRING	AUG	-	-	-	-	-	-
3	1202			OWN	-	-	-	-	-	-
				PRE	-	-	-	-	-	-
F-A	V2 21202-088-H001	ISI/VT/	2K5-1202-088-01	ISI	-	-	-	-	s	-
F1.30H(2)	21202-088-H001		VAR SPRING	AUG	-	-	-	-	-	-
3	1202			OWN	-	-	-	-	-	-
				PRE	-	-	-	-	-	-
F-A	V2 21202-088-H010		2K5-1202-088-01	ISI	-	-	-	-	-	-
F1.30H(2)	21202-088-H010		VAR SPRING	AUG	-	-	-	-	-	-
3	1202			OWN	-	-	-	-	-	-
				PRE	-	-	-	-	-	-

**Southern Nuclear Operating Company
3rd Interval
VOGTLE-2 ISI PLAN, VERSION 3.0**

Category, Item No., Class	Summary No./ComplD/System	Scope / Method / Procedure	Dwg/ISO No. Comp. Desc. Code Case		Period 1		Period 2		Period 3	
					2VR13	2VR14	2VR14A	2VR15	2VR16	2VR17
F-A	V2 21202-088-H025		2K5-1202-088-01	ISI	-	-	-	-	-	-
F1.30H(2)	21202-088-H025		VAR SPRING	AUG	-	-	-	-	-	-
3	1202			OWN	-	-	-	-	-	-
				PRE	-	-	-	-	-	-
F-A	V2 21202-088-H026		2K5-1202-088-01	ISI	-	-	-	-	-	-
F1.30H(2)	21202-088-H026		VAR SPRING	AUG	-	-	-	-	-	-
3	1202			OWN	-	-	-	-	-	-
				PRE	-	-	-	-	-	-
F-A	V2 21202-088-H028		2K5-1202-088-01	ISI	-	-	-	-	-	-
F1.30H(2)	21202-088-H028		VAR SPRING	AUG	-	-	-	-	-	-
3	1202			OWN	-	-	-	-	-	-
				PRE	-	-	-	-	-	-
F-A	V2 21202-088-H029		2K5-1202-088-01	ISI	-	-	-	-	-	-
F1.30H(2)	21202-088-H029		VAR SPRING	AUG	-	-	-	-	-	-
3	1202			OWN	-	-	-	-	-	-
				PRE	-	-	-	-	-	-
F-A	V2 21202-088-H032		2K3-1202-036-01	ISI	-	-	-	-	-	-
F1.30H(2)	21202-088-H032		VAR SPRING	AUG	-	-	-	-	-	-
3	1202			OWN	-	-	-	-	-	-
				PRE	-	-	-	-	-	-
F-A	V2 21202-088-H034		2K3-1202-036-01	ISI	-	-	-	-	-	-
F1.30H(2)	21202-088-H034		VAR SPRING	AUG	-	-	-	-	-	-
3	1202			OWN	-	-	-	-	-	-
				PRE	-	-	-	-	-	-
F-A	V2 21202-088-H042		2K3-1202-088-01	ISI	-	-	-	-	-	-
F1.30H(2)	21202-088-H042		VAR SPRING	AUG	-	-	-	-	-	-
3	1202			OWN	-	-	-	-	-	-
				PRE	-	-	-	-	-	-
F-A	V2 21202-088-H046		2K5-1202-088-01	ISI	-	-	-	-	-	-
F1.30H(2)	21202-088-H046		VAR SPRING	AUG	-	-	-	-	-	-
3	1202			OWN	-	-	-	-	-	-
				PRE	-	-	-	-	-	-
F-A	V2 21202-088-H050		2K5-1202-088-01	ISI	-	-	-	-	-	-
F1.30H(2)	21202-088-H050		VAR SPRING	AUG	-	-	-	-	-	-
3	1202			OWN	-	-	-	-	-	-
				PRE	-	-	-	-	-	-
F-A	V2 21202-088-H051		2K5-1202-088-01	ISI	-	-	-	-	-	-
F1.30H(2)	21202-088-H051		VAR SPRING	AUG	-	-	-	-	-	-
3	1202			OWN	-	-	-	-	-	-
				PRE	-	-	-	-	-	-

Southern Nuclear Operating Company
3rd Interval
VOGTLE-2 ISI PLAN, VERSION 3.0

Category, Item No., Class	Summary No./ComplD/System	Scope / Method / Procedure	Dwg/ISO No. Comp. Desc. Code Case		Period 1		Period 2			Period 3	
					2VR13	2VR14	2VR14A	2VR15	2VR16	2VR17	2VR18
F-A	V2 21202-098-H009	ISI/VT/	2K3-1202-098-01	ISI	-	-	-	-	-	s	-
F1.30H(2)	21202-098-H009		VAR SPRING	AUG	-	-	-	-	-	-	-
3	1202			OWN	-	-	-	-	-	-	-
				PRE	-	-	-	-	-	-	-
F-A	V2 21202-099-H024	ISI/VT/	2K3-1202-099-01	ISI	-	-	-	-	-	s	-
F1.30H(2)	21202-099-H024		VAR SPRING	AUG	-	-	-	-	-	-	-
3	1202			OWN	-	-	-	-	-	-	-
				PRE	-	-	-	-	-	-	-
F-A	V2 21202-175-H001		2K3-1202-037-01	ISI	-	-	-	-	-	-	-
F1.30H(2)	21202-175-H001		VAR SPRING	AUG	-	-	-	-	-	-	-
3	1202			OWN	-	-	-	-	-	-	-
				PRE	-	-	-	-	-	-	-
F-A	V2 21202-181-H006		2K5-1202-181-01	ISI	-	-	-	-	-	-	-
F1.30H(2)	21202-181-H006		VAR SPRING	AUG	-	-	-	-	-	-	-
3	1202			OWN	-	-	-	-	-	-	-
				PRE	-	-	-	-	-	-	-
F-A	V2 21202-181-H009		2K5-1202-181-01	ISI	-	-	-	-	-	-	-
F1.30H(2)	21202-181-H009		VAR SPRING	AUG	-	-	-	-	-	-	-
3	1202			OWN	-	-	-	-	-	-	-
				PRE	-	-	-	-	-	-	-
F-A	V2 21202-181-H028		2K3-1202-181-01	ISI	-	-	-	-	-	-	-
F1.30H(2)	21202-181-H028		VAR SPRING	AUG	-	-	-	-	-	-	-
3	1202			OWN	-	-	-	-	-	-	-
				PRE	-	-	-	-	-	-	-
F-A	V2 21202-181-H034		2K5-1202-181-01	ISI	-	-	-	-	-	-	-
F1.30H(2)	21202-181-H034		VAR SPRING	AUG	-	-	-	-	-	-	-
3	1202			OWN	-	-	-	-	-	-	-
				PRE	-	-	-	-	-	-	-
F-A	V2 21202-181-H035		2K5-1202-181-01	ISI	-	-	-	-	-	-	-
F1.30H(2)	21202-181-H035		VAR SPRING	AUG	-	-	-	-	-	-	-
3	1202			OWN	-	-	-	-	-	-	-
				PRE	-	-	-	-	-	-	-
F-A	V2 21202-181-H037		2K5-1202-181-01	ISI	-	-	-	-	-	-	-
F1.30H(2)	21202-181-H037		VAR SPRING	AUG	-	-	-	-	-	-	-
3	1202			OWN	-	-	-	-	-	-	-
				PRE	-	-	-	-	-	-	-
F-A	V2 21202-184-H005		2K5-1202-181-01	ISI	-	-	-	-	-	-	-
F1.30H(2)	21202-184-H005		VAR SPRING	AUG	-	-	-	-	-	-	-
3	1202			OWN	-	-	-	-	-	-	-
				PRE	-	-	-	-	-	-	-

**Southern Nuclear Operating Company
3rd Interval
VOGTLE-2 ISI PLAN, VERSION 3.0**

Category, Item No., Class	Summary No./ComplD/System	Scope / Method / Procedure	Dwg/ISO No. Comp. Desc. Code Case		Period 1		Period 2			Period 3	
					2VR13	2VR14	2VR14A	2VR15	2VR16	2VR17	2VR18
F-A F1.30H(2) 3	V2 21202-185-H004 21202-185-H004 1202		2K5-1202-088-01 VAR SPRING	ISI AUG OWN PRE	-	-	-	-	-	-	-
F-A F1.30H(2) 3	V2 21202-187-H009 21202-187-H009 1202		2K3-1202-187-03 VAR SPRING	ISI AUG OWN PRE	-	-	-	-	-	-	-
F-A F1.30H(2) 3	V2 21202-232-H007 21202-232-H007 1202		2K7-1202-232-01 VAR SPRING	ISI AUG OWN PRE	-	-	-	-	-	-	-
F-A F1.30H(2) 3	V2 21202-390-H008 21202-390-H008 1202	ISI/VT/	2K3-1202-037-01 VAR SPRING	ISI AUG OWN PRE	-	-	-	-	-	s	-
F-A F1.30H(2) 3	V2 21202-487-H002 21202-487-H002 1202		2K5-1202-181-01 VAR SPRING	ISI AUG OWN PRE	-	-	-	-	-	-	-
F-A F1.30H(2) 3	V2 21202-488-H001 21202-488-H001 1202		2K5-1202-088-01 VAR SPRING	ISI AUG OWN PRE	-	-	-	-	-	-	-
F-A F1.30H(2) 3	V2 21203-021-H003 21203-021-H003 1203		2K3-1203-021-01 VAR SPRING	ISI AUG OWN PRE	-	-	-	-	-	-	-
F-A F1.30H(2) 3	V2 21203-021-H007 21203-021-H007 1203		2K3-1203-021-02 VAR SPRING	ISI AUG OWN PRE	-	-	-	-	-	-	-
F-A F1.30H(2) 3	V2 21203-021-H012 21203-021-H012 1203		2K3-1203-021-02 VAR SPRING	ISI AUG OWN PRE	-	-	-	-	-	-	-
F-A F1.30H(2) 3	V2 21203-026-H003 21203-026-H003 1203	ISI/VT/NMP-ES-024-203	2K3-1203-026-01 VAR SPRING	ISI AUG OWN PRE	c	-	-	-	-	-	-

Southern Nuclear Operating Company
3rd Interval
VOGTLE-2 ISI PLAN, VERSION 3.0

Category, Item No., Class	Summary No./ComplD/System	Scope / Method / Procedure	Dwg/ISO No. Comp. Desc. Code Case		Period 1		Period 2			Period 3	
					2VR13	2VR14	2VR14A	2VR15	2VR16	2VR17	2VR18
F-A	V2 21203-026-H006		2K3-1203-026-01	ISI	-	-	-	-	-	-	-
F1.30H(2)	21203-026-H006		VAR SPRING	AUG	-	-	-	-	-	-	-
3	1203			OWN	-	-	-	-	-	-	-
				PRE	-	-	-	-	-	-	-
F-A	V2 21203-026-H007		2K3-1203-026-01	ISI	-	-	-	-	-	-	-
F1.30H(2)	21203-026-H007		VAR SPRING	AUG	-	-	-	-	-	-	-
3	1203			OWN	-	-	-	-	-	-	-
				PRE	-	-	-	-	-	-	-
F-A	V2 21203-026-H609		2K3-1203-026-02	ISI	-	-	-	-	-	-	-
F1.30H(2)	21203-026-H609		VAR SPRING	AUG	-	-	-	-	-	-	-
3	1203			OWN	-	-	-	-	-	-	-
				PRE	-	-	-	-	-	-	-
F-A	V2 21203-028-H001		2K3-1203-026-01	ISI	-	-	-	-	-	-	-
F1.30H(2)	21203-028-H001		VAR SPRING	AUG	-	-	-	-	-	-	-
3	1203			OWN	-	-	-	-	-	-	-
				PRE	-	-	-	-	-	-	-
F-A	V2 21203-030-H001		2K3-1203-026-01	ISI	-	-	-	-	-	-	-
F1.30H(2)	21203-030-H001		VAR SPRING	AUG	-	-	-	-	-	-	-
3	1203			OWN	-	-	-	-	-	-	-
				PRE	-	-	-	-	-	-	-
F-A	V2 21203-032-H001		2K3-1203-034-02	ISI	-	-	-	-	-	-	-
F1.30H(2)	21203-032-H001		VAR SPRING	AUG	-	-	-	-	-	-	-
3	1203			OWN	-	-	-	-	-	-	-
				PRE	-	-	-	-	-	-	-
F-A	V2 21203-033-H001		2K3-1203-034-02	ISI	-	-	-	-	-	-	-
F1.30H(2)	21203-033-H001		VAR SPRING	AUG	-	-	-	-	-	-	-
3	1203			OWN	-	-	-	-	-	-	-
				PRE	-	-	-	-	-	-	-
F-A	V2 21203-034-H006		2K3-1203-034-01	ISI	-	-	-	-	-	-	-
F1.30H(2)	21203-034-H006		VAR SPRING	AUG	-	-	-	-	-	-	-
3	1203			OWN	-	-	-	-	-	-	-
				PRE	-	-	-	-	-	-	-
F-A	V2 21203-034-H010		2K3-1203-034-01	ISI	-	-	-	-	-	-	-
F1.30H(2)	21203-034-H010		VAR SPRING	AUG	-	-	-	-	-	-	-
3	1203			OWN	-	-	-	-	-	-	-
				PRE	-	-	-	-	-	-	-
F-A	V2 21203-034-H011		2K3-1203-034-02	ISI	-	-	-	-	-	-	-
F1.30H(2)	21203-034-H011		VAR SPRING	AUG	-	-	-	-	-	-	-
3	1203			OWN	-	-	-	-	-	-	-
				PRE	-	-	-	-	-	-	-

**Southern Nuclear Operating Company
3rd Interval
VOGTLE-2 ISI PLAN, VERSION 3.0**

Category, Item No., Class	Summary No./CompID/System	Scope / Method / Procedure	Dwg/ISO No. Comp. Desc. Code Case		Period 1		Period 2		Period 3		
					2VR13	2VR14	2VR14A	2VR15	2VR16	2VR17	2VR18
F-A F1.30H(2) 3	V2 21203-042-H003 21203-042-H003 1203		2K3-1203-042-01 VAR SPRING	ISI AUG OWN PRE	-	-	-	-	-	-	-
F-A F1.30H(2) 3	V2 21203-042-H013 21203-042-H013 1203		2K3-1203-042-03 VAR SPRING	ISI AUG OWN PRE	-	-	-	-	-	-	-
F-A F1.30H(2) 3	V2 21203-042-H016 21203-042-H016 1203		2K3-1203-042-04 VAR SPRING	ISI AUG OWN PRE	-	-	-	-	-	-	-
F-A F1.30H(2) 3	V2 21203-047-H008 21203-047-H008 1203		2K3-1203-047-01 VAR SPRING	ISI AUG OWN PRE	-	-	-	-	-	-	-
F-A F1.30H(2) 3	V2 21203-053-H001 21203-053-H001 1203		2K3-1203-055-02 VAR SPRING	ISI AUG OWN PRE	-	-	-	-	-	-	-
F-A F1.30H(2) 3	V2 21203-054-H001 21203-054-H001 1203		2K3-1203-055-02 VAR SPRING	ISI AUG OWN PRE	-	-	-	-	-	-	-
F-A F1.30H(2) 3	V2 21203-055-H007 21203-055-H007 1203		2K3-1203-055-02 VAR SPRING	ISI AUG OWN PRE	-	-	-	-	-	-	-
F-A F1.30H(2) 3	V2 21203-055-H603 21203-055-H603 1203		VAR SPRING	ISI AUG OWN PRE	-	-	-	-	-	-	-
F-A F1.30H(2) 3	V2 21203-065-H001 21203-065-H001 1203	ISI/VT/	VAR SPRING	ISI AUG OWN PRE	-	-	-	-	-	s	-
F-A F1.30H(2) 3	V2 21203-091-H009 21203-091-H009 1203		2K7-1203-091-01 VAR SPRING	ISI AUG OWN PRE	-	-	-	-	-	-	-

Southern Nuclear Operating Company
3rd Interval
VOGTLE-2 ISI PLAN, VERSION 3.0

Category, Item No., Class	Summary No./ComplD/System	Scope / Method / Procedure	Dwg/ISO No. Comp. Desc. Code Case		Period 1		Period 2		Period 3	
					2VR13	2VR14	2VR14A	2VR15	2VR16	2VR17
F-A	V2 21302-007-H001	ISI/VT/	2K5-1302-007-01	ISI	-	-	-	s	-	-
F1.30H(2)	21302-007-H001		VAR SPRING	AUG	-	-	-	-	-	-
3	1302			OWN	-	-	-	-	-	-
				PRE	-	-	-	-	-	-
F-A	V2 21302-007-H006		2K5-1302-007-01	ISI	-	-	-	-	-	-
F1.30H(2)	21302-007-H006		VAR SPRING	AUG	-	-	-	-	-	-
3	1302			OWN	-	-	-	-	-	-
				PRE	-	-	-	-	-	-
F-A	V2 21302-016-H008		2K5-1302-016-01	ISI	-	-	-	-	-	-
F1.30H(2)	21302-016-H008		VAR SPRING	AUG	-	-	-	-	-	-
3	1302			OWN	-	-	-	-	-	-
				PRE	-	-	-	-	-	-
F-A	V2 21302-017-H007		2K5-1302-017-01	ISI	-	-	-	-	-	-
F1.30H(2)	21302-017-H007		VAR SPRING	AUG	-	-	-	-	-	-
3	1302			OWN	-	-	-	-	-	-
				PRE	-	-	-	-	-	-
F-A	V2 21302-024-H001		2K5-1302-024-01	ISI	-	-	-	-	-	-
F1.30H(2)	21302-024-H001		VAR SPRING	AUG	-	-	-	-	-	-
3	1302			OWN	-	-	-	-	-	-
				PRE	-	-	-	-	-	-
F-A	V2 21302-045-H001		2K5-1302-045-01	ISI	-	-	-	-	-	-
F1.30H(2)	21302-045-H001		VAR SPRING	AUG	-	-	-	-	-	-
3	1302			OWN	-	-	-	-	-	-
				PRE	-	-	-	-	-	-
F-A	V2 21302-046-H004		2K5-1302-046-01	ISI	-	-	-	-	-	-
F1.30H(2)	21302-046-H004		VAR SPRING	AUG	-	-	-	-	-	-
3	1302			OWN	-	-	-	-	-	-
				PRE	-	-	-	-	-	-
F-A	V2 21302-048-H001		2K5-1302-048-01	ISI	-	-	-	-	-	-
F1.30H(2)	21302-048-H001		VAR SPRING	AUG	-	-	-	-	-	-
3	1302			OWN	-	-	-	-	-	-
				PRE	-	-	-	-	-	-
F-A	V2 21592-004-H612	ISI/VT/	2K2-1592-004-01	ISI	-	-	-	s	-	-
F1.30H(2)	21592-004-H612		VAR SPRING	AUG	-	-	-	-	-	-
3	1592			OWN	-	-	-	-	-	-
				PRE	-	-	-	-	-	-
F-A	V2 21202-002-H008		2K3-1202-002-02	ISI	-	-	-	-	-	-
F1.30S	21202-002-H008		MECH SNUBBER	AUG	-	-	-	-	-	-
3	1202			OWN	-	-	-	-	-	-
				PRE	-	-	-	-	-	-

Southern Nuclear Operating Company
3rd Interval
VOGTLE-2 ISI PLAN, VERSION 3.0

Category, Item No., Class	Summary No./ComplID/System	Scope / Method / Procedure	Dwg/ISO No. Comp. Desc. Code Case		Period 1		Period 2		Period 3	
					2VR13	2VR14	2VR14A	2VR15	2VR16	2VR17
F-A	V2 21202-004-H056		2K5-1202-004-02	ISI	-	-	-	-	-	-
F1.30S	21202-004-H056		MECH SNUBBER	AUG	-	-	-	-	-	-
3	1202			OWN	-	-	-	-	-	-
				PRE	-	-	-	-	-	-
F-A	V2 21203-021-H006		2K3-1203-021-02	ISI	-	-	-	-	-	-
F1.30S	21203-021-H006		MECH SNUBBER	AUG	-	-	-	-	-	-
3	1203			OWN	-	-	-	-	-	-
				PRE	-	-	-	-	-	-
F-A	V2 21217-072-H619A		2J4-1217-072-01	ISI	-	-	-	-	-	-
F1.30S	21217-072-H619W		MECH SNUBBER	AUG	-	-	-	-	-	-
3	1217			OWN	-	-	-	-	-	-
				PRE	-	-	-	-	-	-
F-A	V2 21217-072-H619B	ISI/VT/	2J4-1217-072-01	ISI	-	-	-	s	-	-
F1.30S	21217-072-H619B		MECH SNUBBER	AUG	-	-	-	-	-	-
3	1217			OWN	-	-	-	-	-	-
				PRE	-	-	-	-	-	-
F-A	V2 21217-072-H620A		2J4-1217-072-01	ISI	-	-	-	-	-	-
F1.30S	21217-072-H620T		MECH SNUBBER	AUG	-	-	-	-	-	-
3	1217			OWN	-	-	-	-	-	-
				PRE	-	-	-	-	-	-
F-A	V2 21217-072-H620B		2J4-1217-072-01	ISI	-	-	-	-	-	-
F1.30S	21217-072-H620NW		MECH SNUBBER	AUG	-	-	-	-	-	-
3	1217			OWN	-	-	-	-	-	-
				PRE	-	-	-	-	-	-
F-A	V2 21217-267-H611		2J4-1217-267-01	ISI	-	-	-	-	-	-
F1.30S	21217-267-H611		MECH SNUBBER	AUG	-	-	-	-	-	-
3	1217			OWN	-	-	-	-	-	-
				PRE	-	-	-	-	-	-
F-A	V2 21301-010-H038		2K3-1301-010-02	ISI	-	-	-	-	-	-
F1.30S	21301-010-H038		MECH SNUBBER	AUG	-	-	-	-	-	-
3	1301			OWN	-	-	-	-	-	-
				PRE	-	-	-	-	-	-
F-A	V2 21301-010-H042A	ISI/VT/	2K5-1301-012-02	ISI	-	-	-	-	s	-
F1.30S	21301-010-H042T		MECH SNUBBER	AUG	-	-	-	-	-	-
3	1301			OWN	-	-	-	-	-	-
				PRE	-	-	-	-	-	-
F-A	V2 21301-010-H042B		2K5-1301-012-02	ISI	-	-	-	-	-	-
F1.30S	21301-010-H042B		MECH SNUBBER	AUG	-	-	-	-	-	-
3	1301			OWN	-	-	-	-	-	-
				PRE	-	-	-	-	-	-

Southern Nuclear Operating Company
3rd Interval
VOGTLE-2 ISI PLAN, VERSION 3.0

Category, Item No., Class	Summary No./ComplD/System	Scope / Method / Procedure	Dwg/ISO No. Comp. Desc. Code Case		Period 1		Period 2			Period 3	
					2VR13	2VR14	2VR14A	2VR15	2VR16	2VR17	2VR18
F-A	V2 21301-012-H014		2K2-1301-012-01	ISI	-	-	-	-	-	-	-
F1.30S	21301-012-H014		MECH SNUBBER	AUG	-	-	-	-	-	-	-
3	1301			OWN	-	-	-	-	-	-	-
				PRE	-	-	-	-	-	-	-
F-A	V2 21301-012-H019		2K5-1301-012-02	ISI	-	-	-	-	-	-	-
F1.30S	21301-012-H019		MECH SNUBBER	AUG	-	-	-	-	-	-	-
3	1301			OWN	-	-	-	-	-	-	-
				PRE	-	-	-	-	-	-	-
F-A	V2 21301-012-H023		2K5-1301-012-02	ISI	-	-	-	-	-	-	-
F1.30S	21301-012-H023		MECH SNUBBER	AUG	-	-	-	-	-	-	-
3	1301			OWN	-	-	-	-	-	-	-
				PRE	-	-	-	-	-	-	-
F-A	V2 21301-012-H028A		2K5-1301-012-02	ISI	-	-	-	-	-	-	-
F1.30S	21301-012-H028		LISEGA HYD SNUBBER	AUG	-	-	-	-	-	-	-
3	1301			OWN	-	-	-	-	-	-	-
				PRE	-	-	-	-	-	-	-
F-A	V2 21301-012-H033A		2K5-1301-012-02	ISI	-	-	-	-	-	-	-
F1.30S	21301-012-H033T		MECH SNUBBER	AUG	-	-	-	-	-	-	-
3	1301			OWN	-	-	-	-	-	-	-
				PRE	-	-	-	-	-	-	-
F-A	V2 21301-012-H033B		2K5-1301-012-02	ISI	-	-	-	-	-	-	-
F1.30S	21301-012-H033B		MECH SNUBBER	AUG	-	-	-	-	-	-	-
3	1301			OWN	-	-	-	-	-	-	-
				PRE	-	-	-	-	-	-	-
F-A	V2 21302-007-H004	ISI/VT/	2K5-1302-007-01	ISI	-	-	-	s	-	-	-
F1.30S	21302-007-H004		MECH SNUBBER	AUG	-	-	-	-	-	-	-
3	1302			OWN	-	-	-	-	-	-	-
				PRE	-	-	-	-	-	-	-
F-A	V2 21202-002-H005		2K3-1202-002-01	ISI	-	-	-	-	-	-	-
F1.30U(2)	21202-002-H005		UNDERSUPPORT	AUG	-	-	-	-	-	-	-
3	1202			OWN	-	-	-	-	-	-	-
				PRE	-	-	-	-	-	-	-
F-A	V2 21202-004-H066		2K5-1202-004-01	ISI	-	-	-	-	-	-	-
F1.30U(2)	21202-004-H066		UNDERSUPPORT	AUG	-	-	-	-	-	-	-
3	1202			OWN	-	-	-	-	-	-	-
				PRE	-	-	-	-	-	-	-
F-A	V2 21202-006-H034	ISI/VT/	2K5-1202-006-01	ISI	-	-	-	s	-	-	-
F1.30U(2)	21202-006-H034		UNDERSUPPORT	AUG	-	-	-	-	-	-	-
3	1202			OWN	-	-	-	-	-	-	-
				PRE	-	-	-	-	-	-	-

Southern Nuclear Operating Company
3rd Interval
VOGTLE-2 ISI PLAN, VERSION 3.0

Category, Item No., Class	Summary No./CompID/System	Scope / Method / Procedure	Dwg/ISO No. Comp. Desc. Code Case		Period 1		Period 2		Period 3	
					2VR13	2VR14	2VR14A	2VR15	2VR16	2VR17
F-A F1.30U(2) 3	V2 21202-006-H036		2K5-1202-006-01	ISI	-	-	-	-	-	-
	21202-006-H036		UNDERSUPPORT	AUG	-	-	-	-	-	-
	1202			OWN	-	-	-	-	-	-
				PRE	-	-	-	-	-	-
F-A F1.30U(2) 3	V2 21202-038-H008		2K5-1202-038-01	ISI	-	-	-	-	-	-
	21202-038-H008		UNDERSUPPORT	AUG	-	-	-	-	-	-
	1202			OWN	-	-	-	-	-	-
				PRE	-	-	-	-	-	-
F-A F1.30U(2) 3	V2 21202-088-H015		2K5-1202-088-01	ISI	-	-	-	-	-	-
	21202-088-H015		UNDERSUPPORT	AUG	-	-	-	-	-	-
	1202			OWN	-	-	-	-	-	-
				PRE	-	-	-	-	-	-
F-A F1.30U(2) 3	V2 21202-088-H016		2K5-1202-088-01	ISI	-	-	-	-	-	-
	21202-088-H016		UNDERSUPPORT	AUG	-	-	-	-	-	-
	1202			OWN	-	-	-	-	-	-
				PRE	-	-	-	-	-	-
F-A F1.30U(2) 3	V2 21202-098-H012		2K3-1202-098-01	ISI	-	-	-	-	-	-
	21202-098-H012		UNDERSUPPORT	AUG	-	-	-	-	-	-
	1202			OWN	-	-	-	-	-	-
				PRE	-	-	-	-	-	-
F-A F1.30U(2) 3	V2 21202-099-H009		2K3-1202-099-01	ISI	-	-	-	-	-	-
	21202-099-H009		UNDERSUPPORT	AUG	-	-	-	-	-	-
	1202			OWN	-	-	-	-	-	-
				PRE	-	-	-	-	-	-
F-A F1.30U(2) 3	V2 21202-099-H011		2K3-1202-099-01	ISI	-	-	-	-	-	-
	21202-099-H011		UNDERSUPPORT	AUG	-	-	-	-	-	-
	1202			OWN	-	-	-	-	-	-
				PRE	-	-	-	-	-	-
F-A F1.30U(2) 3	V2 21202-099-H012		2K3-1202-099-01	ISI	-	-	-	-	-	-
	21202-099-H012		UNDERSUPPORT	AUG	-	-	-	-	-	-
	1202			OWN	-	-	-	-	-	-
				PRE	-	-	-	-	-	-
F-A F1.30U(2) 3	V2 21202-099-H014		2K3-1202-099-01	ISI	-	-	-	-	-	-
	21202-099-H014		UNDERSUPPORT	AUG	-	-	-	-	-	-
	1202			OWN	-	-	-	-	-	-
				PRE	-	-	-	-	-	-
F-A F1.30U(2) 3	V2 21202-104-H018		2K3-1202-104-01	ISI	-	-	-	-	-	-
	21202-104-H018		UNDERSUPPORT	AUG	-	-	-	-	-	-
	1202			OWN	-	-	-	-	-	-
				PRE	-	-	-	-	-	-

Southern Nuclear Operating Company
3rd Interval
VOGTLE-2 ISI PLAN, VERSION 3.0

Category, Item No., Class	Summary No./CompID/System	Scope / Method / Procedure	Dwg/ISO No. Comp. Desc. Code Case		Period 1		Period 2			Period 3	
					2VR13	2VR14	2VR14A	2VR15	2VR16	2VR17	2VR18
F-A F1.30U(2) 3	V2 21202-104-H028		2K3-1202-104-01 UNDERSUPPORT	ISI	-	-	-	-	-	-	-
	21202-104-H028			AUG	-	-	-	-	-	-	-
	1202			OWN	-	-	-	-	-	-	-
				PRE	-	-	-	-	-	-	-
F-A F1.30U(2) 3	V2 21202-104-H030		2K3-1202-104-01 UNDERSUPPORT	ISI	-	-	-	-	-	-	-
	21202-104-H030			AUG	-	-	-	-	-	-	-
	1202			OWN	-	-	-	-	-	-	-
				PRE	-	-	-	-	-	-	-
F-A F1.30U(2) 3	V2 21202-104-H031		2K3-1202-104-01 UNDERSUPPORT	ISI	-	-	-	-	-	-	-
	21202-104-H031			AUG	-	-	-	-	-	-	-
	1202			OWN	-	-	-	-	-	-	-
				PRE	-	-	-	-	-	-	-
F-A F1.30U(2) 3	V2 21202-134-H029		2K3-1202-134-01 UNDERSUPPORT	ISI	-	-	-	-	-	-	-
	21202-134-H029			AUG	-	-	-	-	-	-	-
	1202			OWN	-	-	-	-	-	-	-
				PRE	-	-	-	-	-	-	-
F-A F1.30U(2) 3	V2 21202-134-H031		2K3-1202-134-01 UNDERSUPPORT	ISI	-	-	-	-	-	-	-
	21202-134-H031			AUG	-	-	-	-	-	-	-
	1202			OWN	-	-	-	-	-	-	-
				PRE	-	-	-	-	-	-	-
F-A F1.30U(2) 3	V2 21202-390-H003		2K3-1202-037-01 UNDERSUPPORT	ISI	-	-	-	-	-	-	-
	21202-390-H003			AUG	-	-	-	-	-	-	-
	1202			OWN	-	-	-	-	-	-	-
				PRE	-	-	-	-	-	-	-
F-A F1.30U(2) 3	V2 21203-021-H018	ISI/VT/	2K3-1203-021-03 UNDERSUPPORT	ISI	-	-	-	-	-	s	-
	21203-021-H018	AUG		-	-	-	-	-	-	-	-
	1203	OWN		-	-	-	-	-	-	-	-
		PRE		-	-	-	-	-	-	-	-
F-A F1.30U(2) 3	V2 21592-003-H006		2K2-1592-003-01 UNDERSUPPORT	ISI	-	-	-	-	-	-	-
	21592-003-H006			AUG	-	-	-	-	-	-	-
	1592			OWN	-	-	-	-	-	-	-
				PRE	-	-	-	-	-	-	-
F-A F1.30U(2) 3	V2 21592-044-H012		2K3-1592-044-03 UNDERSUPPORT	ISI	-	-	-	-	-	-	-
	21592-044-H012			AUG	-	-	-	-	-	-	-
	1592			OWN	-	-	-	-	-	-	-
				PRE	-	-	-	-	-	-	-
F-A F1.30U(2) 3	V2 21592-044-H047		2K3-1592-044-03 UNDERSUPPORT	ISI	-	-	-	-	-	-	-
	21592-044-H047			AUG	-	-	-	-	-	-	-
	1592			OWN	-	-	-	-	-	-	-
				PRE	-	-	-	-	-	-	-

Southern Nuclear Operating Company
3rd Interval
VOGTLE-2 ISI PLAN, VERSION 3.0

Category, Item No., Class	Summary No./ComplD/System	Scope / Method / Procedure	Dwg/ISO No. Comp. Desc. Code Case			Period 1		Period 2		Period 3	
						2VR13	2VR14	2VR14A	2VR15	2VR16	2VR17
F-A F1.40(2) 1	V2 21201-B6-001-S01 21201-B6-001-S01 1201	ISI/VT/	ISI-21201-B6-001 Steam gen supp	2X6AB18-11	ISI AUG OWN PRE	- - - -	- - - -	- - - -	- - - -	s - - -	- - - -
F-A F1.40(2) 1	V2 21201-B6-001-S02 21201-B6-001-S02 1201	ISI/VT/	ISI-21201-B6-001 Steam gen supp	2X6AB18-11	ISI AUG OWN PRE	- - - -	- - - -	- - - -	- - - -	s - - -	- - - -
F-A F1.40(2) 1	V2 21201-B6-001-S03 21201-B6-001-S03 1201	ISI/VT/	ISI-21201-B6-001 Steam gen supp	2X6AB18-11	ISI AUG OWN PRE	- - - -	- - - -	- - - -	- - - -	s - - -	- - - -
F-A F1.40(2) 1	V2 21201-B6-001-S04 21201-B6-001-S04 1201	ISI/VT/	ISI-21201-B6-001 Steam gen supp	2X6AB18-11	ISI AUG OWN PRE	- - - -	- - - -	- - - -	- - - -	s - - -	- - - -
F-A F1.40(2) 2	V2 21201-B6-001-S10 21201-B6-001-S10 1201	ISI/VT/	ISI-21201-B6-001 Upper supp frame	2X6AB18-16	ISI AUG OWN PRE	- - - -	- - - -	- - - -	- - - -	s - - -	- - - -
F-A F1.40(2) 1	V2 21201-B6-001-S11 21201-B6-001-S11 1201	ISI/VT/	ISI-21201-B6-001 Lower lat supp	2X6AB18-12	ISI AUG OWN PRE	- - - -	- - - -	- - - -	- - - -	s - - -	- - - -
F-A F1.40(2) 1	V2 21201-B6-001-S12 21201-B6-001-S12 1201	ISI/VT/	ISI-21201-B6-001 Lower lat supp	2X6AB18-12	ISI AUG OWN PRE	- - - -	- - - -	- - - -	- - - -	s - - -	- - - -
F-A F1.40(2) 1	V2 21201-B6-001-S13 21201-B6-001-S13 1201	ISI/VT/	ISI-21201-B6-001 Lower lat supp	2X6AB18-12	ISI AUG OWN PRE	- - - -	- - - -	- - - -	- - - -	s - - -	- - - -
F-A F1.40(2) 1	V2 21201-B6-002-S01 21201-B6-002-S01 1201		ISI-21201-B6-002 Steam gen supp	2X6AB18-11	ISI AUG OWN PRE	- - - -	- - - -	- - - -	- - - -	- - - -	- - - -
F-A F1.40(2) 1	V2 21201-B6-002-S02 21201-B6-002-S02 1201		ISI-21201-B6-002 Steam gen supp	2X6AB18-11	ISI AUG OWN PRE	- - - -	- - - -	- - - -	- - - -	- - - -	- - - -

Southern Nuclear Operating Company
3rd Interval
VOGTLE-2 ISI PLAN, VERSION 3.0

Category, Item No., Class	Summary No./CompID/System	Scope / Method / Procedure	Dwg/ISO No. Comp. Desc. Code Case			Period 1		Period 2		Period 3	
						2VR13	2VR14	2VR14A	2VR15	2VR16	2VR17
F-A F1.40(2) 1	V2 21201-B6-002-S03 21201-B6-002-S03 1201		ISI-21201-B6-002 Steam gen supp	2X6AB18-11	ISI AUG OWN PRE	-	-	-	-	-	-
F-A F1.40(2) 1	V2 21201-B6-002-S04 21201-B6-002-S04 1201		ISI-21201-B6-002 Steam gen supp	2X6AB18-11	ISI AUG OWN PRE	-	-	-	-	-	-
F-A F1.40(2) 2	V2 21201-B6-002-S10 21201-B6-002-S10 1201		ISI-21201-B6-002 Upper supp frame	2X6AB18-16	ISI AUG OWN PRE	-	-	-	-	-	-
F-A F1.40(2) 1	V2 21201-B6-002-S11 21201-B6-002-S11 1201		ISI-21201-B6-002 Lower lat supp	2X6AB18-12	ISI AUG OWN PRE	-	-	-	-	-	-
F-A F1.40(2) 1	V2 21201-B6-002-S12 21201-B6-002-S12 1201		ISI-21201-B6-002 Lower lat supp	2X6AB18-12	ISI AUG OWN PRE	-	-	-	-	-	-
F-A F1.40(2) 1	V2 21201-B6-002-S13 21201-B6-002-S13 1201		ISI-21201-B6-002 Lower lat supp	2X6AB18-12	ISI AUG OWN PRE	-	-	-	-	-	-
F-A F1.40(2) 1	V2 21201-B6-003-S01 21201-B6-003-S01 1201		ISI-21201-B6-003 Steam gen supp	2X6AB18-11	ISI AUG OWN PRE	-	-	-	-	-	-
F-A F1.40(2) 1	V2 21201-B6-003-S02 21201-B6-003-S02 1201		ISI-21201-B6-003 Steam gen supp	2X6AB18-11	ISI AUG OWN PRE	-	-	-	-	-	-
F-A F1.40(2) 1	V2 21201-B6-003-S03 21201-B6-003-S03 1201		ISI-21201-B6-003 Steam gen supp	2X6AB18-11	ISI AUG OWN PRE	-	-	-	-	-	-
F-A F1.40(2) 1	V2 21201-B6-003-S04 21201-B6-003-S04 1201		ISI-21201-B6-003 Steam gen supp	2X6AB18-11	ISI AUG OWN PRE	-	-	-	-	-	-

Southern Nuclear Operating Company
3rd Interval
VOGTLE-2 ISI PLAN, VERSION 3.0

Category, Item No., Class	Summary No./ComplD/System	Scope / Method / Procedure	Dwg/ISO No. Comp. Desc. Code Case		Period 1		Period 2		Period 3	
					2VR13	2VR14	2VR14A	2VR15	2VR16	2VR17
F-A F1.40(2) 2	V2 21201-B6-003-S10 21201-B6-003-S10 1201		ISI-21201-B6-003 Upper supp frame	2X6AB18-16	ISI AUG OWN PRE	- - - -	- - - -	- - - -	- - - -	- - - -
F-A F1.40(2) 1	V2 21201-B6-003-S11 21201-B6-003-S11 1201		ISI-21201-B6-003 Lower lat supp	2X6AB18-12	ISI AUG OWN PRE	- - - -	- - - -	- - - -	- - - -	- - - -
F-A F1.40(2) 1	V2 21201-B6-003-S12 21201-B6-003-S12 1201		ISI-21201-B6-003 Lower lat supp	2X6AB18-12	ISI AUG OWN PRE	- - - -	- - - -	- - - -	- - - -	- - - -
F-A F1.40(2) 1	V2 21201-B6-003-S13 21201-B6-003-S13 1201		ISI-21201-B6-003 Lower lat supp	2X6AB18-12	ISI AUG OWN PRE	- - - -	- - - -	- - - -	- - - -	- - - -
F-A F1.40(2) 1	V2 21201-B6-004-S01 21201-B6-004-S01 1201		ISI-21201-B6-004 Steam gen supp	2X6AB18-11	ISI AUG OWN PRE	- - - -	- - - -	- - - -	- - - -	- - - -
F-A F1.40(2) 1	V2 21201-B6-004-S02 21201-B6-004-S02 1201		ISI-21201-B6-004 Steam gen supp	2X6AB18-11	ISI AUG OWN PRE	- - - -	- - - -	- - - -	- - - -	- - - -
F-A F1.40(2) 1	V2 21201-B6-004-S03 21201-B6-004-S03 1201		ISI-21201-B6-004 Steam gen supp	2X6AB18-11	ISI AUG OWN PRE	- - - -	- - - -	- - - -	- - - -	- - - -
F-A F1.40(2) 1	V2 21201-B6-004-S04 21201-B6-004-S04 1201		ISI-21201-B6-004 Steam gen supp	2X6AB18-11	ISI AUG OWN PRE	- - - -	- - - -	- - - -	- - - -	- - - -
F-A F1.40(2) 2	V2 21201-B6-004-S10 21201-B6-004-S10 1201		ISI-21201-B6-004 Upper supp frame	2X6AB18-16	ISI AUG OWN PRE	- - - -	- - - -	- - - -	- - - -	- - - -
F-A F1.40(2) 1	V2 21201-B6-004-S11 21201-B6-004-S11 1201		ISI-21201-B6-004 Lower lat supp	2X6AB18-12	ISI AUG OWN PRE	- - - -	- - - -	- - - -	- - - -	- - - -

Southern Nuclear Operating Company
3rd Interval
VOGTLE-2 ISI PLAN, VERSION 3.0

Category, Item No., Class	Summary No./ComplD/System	Scope / Method / Procedure	Dwg/ISO No. Comp. Desc. Code Case		Period 1		Period 2			Period 3	
					2VR13	2VR14	2VR14A	2VR15	2VR16	2VR17	2VR18
F-A F1.40(2) 1	V2 21201-B6-004-S12 21201-B6-004-S12 1201		ISI-21201-B6-004 Lower lat supp	2X6AB18-12	ISI AUG OWN PRE	- - - -	- - - -	- - - -	- - - -	- - - -	- - - -
F-A F1.40(2) 1	V2 21201-B6-004-S13 21201-B6-004-S13 1201		ISI-21201-B6-004 Lower lat supp	2X6AB18-12	ISI AUG OWN PRE	- - - -	- - - -	- - - -	- - - -	- - - -	- - - -
F-A F1.40(2) 1	V2 21201-P6-001-SP01 21201-P6-001-SP01 1201		2X6AB18-11 Pump support		ISI AUG OWN PRE	- - - -	- - - -	- - - -	- - - -	- - - -	- - - -
F-A F1.40(2) 1	V2 21201-P6-001-SP02 21201-P6-001-SP02 1201		2X6AB18-11 Pump support		ISI AUG OWN PRE	- - - -	- - - -	- - - -	- - - -	- - - -	- - - -
F-A F1.40(2) 1	V2 21201-P6-001-SP03 21201-P6-001-SP03 1201		2X6AB18-11 Pump support		ISI AUG OWN PRE	- - - -	- - - -	- - - -	- - - -	- - - -	- - - -
F-A F1.40(2) 1	V2 21201-P6-001-T01 21201-P6-001-T01 1201		2X6AB18-7 Restraint		ISI AUG OWN PRE	- - - -	- - - -	- - - -	- - - -	- - - -	- - - -
F-A F1.40(2) 1	V2 21201-P6-001-T02 21201-P6-001-T02 1201		2X6AB18-7 Restraint		ISI AUG OWN PRE	- - - -	- - - -	- - - -	- - - -	- - - -	- - - -
F-A F1.40(2) 1	V2 21201-P6-001-T03 21201-P6-001-T03 1201		2X6AB18-7 Restraint		ISI AUG OWN PRE	- - - -	- - - -	- - - -	- - - -	- - - -	- - - -
F-A F1.40(2) 1	V2 21201-P6-002-SP01 21201-P6-002-SP01 1201		2X6AB18-11 Pump support		ISI AUG OWN PRE	- - - -	- - - -	- - - -	- - - -	- - - -	- - - -
F-A F1.40(2) 1	V2 21201-P6-002-SP02 21201-P6-002-SP02 1201		2X6AB18-11 Pump support		ISI AUG OWN PRE	- - - -	- - - -	- - - -	- - - -	- - - -	- - - -

Southern Nuclear Operating Company
3rd Interval
VOGTLE-2 ISI PLAN, VERSION 3.0

Category, Item No., Class	Summary No./ComplID/System	Scope / Method / Procedure	Dwg/ISO No. Comp. Desc. Code Case		Period 1		Period 2		Period 3	
					2VR13	2VR14	2VR14A	2VR15	2VR16	2VR17
F-A	V2 21201-P6-002-SP03		2X6AB18-11	ISI	-	-	-	-	-	-
F1.40(2)	21201-P6-002-SP03		Pump support	AUG	-	-	-	-	-	-
1	1201			OWN	-	-	-	-	-	-
				PRE	-	-	-	-	-	-
F-A	V2 21201-P6-002-T01		2X6AB18-7	ISI	-	-	-	-	-	-
F1.40(2)	21201-P6-002-T01		Restraint	AUG	-	-	-	-	-	-
1	1201			OWN	-	-	-	-	-	-
				PRE	-	-	-	-	-	-
F-A	V2 21201-P6-002-T02		2X6AB18-7	ISI	-	-	-	-	-	-
F1.40(2)	21201-P6-002-T02		Restraint	AUG	-	-	-	-	-	-
1	1201			OWN	-	-	-	-	-	-
				PRE	-	-	-	-	-	-
F-A	V2 21201-P6-002-T03		2X6AB18-7	ISI	-	-	-	-	-	-
F1.40(2)	21201-P6-002-T03		Restraint	AUG	-	-	-	-	-	-
1	1201			OWN	-	-	-	-	-	-
				PRE	-	-	-	-	-	-
F-A	V2 21201-P6-003-SP01		2X6AB18-11	ISI	-	-	-	-	-	-
F1.40(2)	21201-P6-003-SP01		Pump support	AUG	-	-	-	-	-	-
1	1201			OWN	-	-	-	-	-	-
				PRE	-	-	-	-	-	-
F-A	V2 21201-P6-003-SP02		2X6AB18-11	ISI	-	-	-	-	-	-
F1.40(2)	21201-P6-003-SP02		Pump support	AUG	-	-	-	-	-	-
1	1201			OWN	-	-	-	-	-	-
				PRE	-	-	-	-	-	-
F-A	V2 21201-P6-003-SP03		2X6AB18-11	ISI	-	-	-	-	-	-
F1.40(2)	21201-P6-003-SP03		Pump support	AUG	-	-	-	-	-	-
1	1201			OWN	-	-	-	-	-	-
				PRE	-	-	-	-	-	-
F-A	V2 21201-P6-003-T01		2X6AB18-7	ISI	-	-	-	-	-	-
F1.40(2)	21201-P6-003-T01		Restraint	AUG	-	-	-	-	-	-
1	1201			OWN	-	-	-	-	-	-
				PRE	-	-	-	-	-	-
F-A	V2 21201-P6-003-T02		2X6AB18-7	ISI	-	-	-	-	-	-
F1.40(2)	21201-P6-003-T02		Restraint	AUG	-	-	-	-	-	-
1	1201			OWN	-	-	-	-	-	-
				PRE	-	-	-	-	-	-
F-A	V2 21201-P6-003-T03		2X6AB18-7	ISI	-	-	-	-	-	-
F1.40(2)	21201-P6-003-T03		Restraint	AUG	-	-	-	-	-	-
1	1201			OWN	-	-	-	-	-	-
				PRE	-	-	-	-	-	-

Southern Nuclear Operating Company
3rd Interval
VOGTLE-2 ISI PLAN, VERSION 3.0

Category, Item No., Class	Summary No./ComplID/System	Scope / Method / Procedure	Dwg/ISO No. Comp. Desc. Code Case		Period 1		Period 2			Period 3	
					2VR13	2VR14	2VR14A	2VR15	2VR16	2VR17	2VR18
F-A F1.40(2) 1	V2 21201-P6-004-SP01 21201-P6-004-SP01 1201	ISI/VT/	2X6AB18-11 Pump support	ISI AUG OWN PRE	- - - -	- - - -	- - - -	s - - -	- - - -	- - - -	- - - -
F-A F1.40(2) 1	V2 21201-P6-004-SP02 21201-P6-004-SP02 1201	ISI/VT/	2X6AB18-11 Pump support	ISI AUG OWN PRE	- - - -	- - - -	- - - -	s - - -	- - - -	- - - -	- - - -
F-A F1.40(2) 1	V2 21201-P6-004-SP03 21201-P6-004-SP03 1201	ISI/VT/	2X6AB18-11 Pump support	ISI AUG OWN PRE	- - - -	- - - -	- - - -	s - - -	- - - -	- - - -	- - - -
F-A F1.40(2) 1	V2 21201-P6-004-T01 21201-P6-004-T01 1201	ISI/VT/	2X6AB18-7 Restraint	ISI AUG OWN PRE	- - - -	- - - -	- - - -	s - - -	- - - -	- - - -	- - - -
F-A F1.40(2) 1	V2 21201-P6-004-T02 21201-P6-004-T02 1201	ISI/VT/	2X6AB18-7 Restraint	ISI AUG OWN PRE	- - - -	- - - -	- - - -	s - - -	- - - -	- - - -	- - - -
F-A F1.40(2) 1	V2 21201-P6-004-T03 21201-P6-004-T03 1201	ISI/VT/	2X6AB18-7 Restraint	ISI AUG OWN PRE	- - - -	- - - -	- - - -	s - - -	- - - -	- - - -	- - - -
F-A F1.40(2) 1	V2 21201-V6-002-H01 21201-V6-002-H01 1201	ISI/VT/NMP-ES-024-203	2184J03C Support skirt	ISI AUG OWN PRE	- - - -	s - - -	- - - -	- - - -	- - - -	- - - -	- - - -
F-A F1.40(2) 1	V2 21201-V6-002-H02 21201-V6-002-H02 1201	ISI/VT/NMP-ES-024-203	2184J03C Seismic restraint	ISI AUG OWN PRE	- - - -	s - - -	- - - -	- - - -	- - - -	- - - -	- - - -
F-A F1.40(2) 1	V2 21201-V6-002-H03 21201-V6-002-H03 1201	ISI/VT/NMP-ES-024-203	2184J03C Seismic restraint	ISI AUG OWN PRE	- - - -	s - - -	- - - -	- - - -	- - - -	- - - -	- - - -
F-A F1.40(2) 1	V2 21201-V6-002-H04 21201-V6-002-H04 1201	ISI/VT/NMP-ES-024-203	2184J03C Seismic restraint	ISI AUG OWN PRE	- - - -	s - - -	- - - -	- - - -	- - - -	- - - -	- - - -

Southern Nuclear Operating Company
3rd Interval
VOGTLE-2 ISI PLAN, VERSION 3.0

Category, Item No., Class	Summary No./ComplD/System	Scope / Method / Procedure	Dwg/ISO No. Comp. Desc. Code Case		Period 1		Period 2			Period 3	
					2VR13	2VR14	2VR14A	2VR15	2VR16	2VR17	2VR18
F-A F1.40(2) 1	V2 21201-V6-002-H05 21201-V6-002-H05 1201	ISI/VT/NMP-ES-024-203	2184J03C Seismic restraint	ISI AUG OWN PRE	-	s	-	-	-	-	-
F-A F1.40(2) 1	V2 21201-V6-002-H06 21201-V6-002-H06 1201	ISI/VT/NMP-ES-024-203	2184J03C Support steel	ISI AUG OWN PRE	-	s	-	-	-	-	-
F-A F1.40(2) 3	V2 21202-P4-001-S01 21202-P4-001-S01 1202		Disch Head Flange	ISI AUG OWN PRE	-	-	-	-	-	-	-
F-A F1.40(2) 3	V2 21202-P4-001-S02 21202-P4-001-S02 1202	ISI/VT/	2X4AF02-18,21 Column restraint	ISI AUG OWN PRE	-	-	-	-	-	s	-
F-A F1.40(2) 3	V2 21202-P4-001-S03 21202-P4-001-S03 1202	ISI/VT/	2X4AF02-18,21 Column restraint	ISI AUG OWN PRE	-	-	-	-	-	s	-
F-A F1.40(2) 3	V2 21202-P4-001-S04 21202-P4-001-S04 1202	ISI/VT/	2X4AF02-18,21 Column restraint	ISI AUG OWN PRE	-	-	-	-	-	s	-
F-A F1.40(2) 3	V2 21202-P4-001-S05 21202-P4-001-S05 1202	ISI/VT/	2X4AF02-18,21 Column restraint	ISI AUG OWN PRE	-	-	-	-	-	s	-
F-A F1.40(2) 3	V2 21202-P4-001-S06 21202-P4-001-S06 1202	ISI/VT/	2X4AF02-18,21 Column restraint	ISI AUG OWN PRE	-	-	-	-	-	s	-
F-A F1.40(2) 3	V2 21202-P4-001-S07 21202-P4-001-S07 1202	ISI/VT/	2X4AF02-18,21 Column restraint	ISI AUG OWN PRE	-	-	-	-	-	s	-
F-A F1.40(2) 3	V2 21202-P4-001-S08 21202-P4-001-S08 1202	ISI/VT/	2X4AF02-18,21 Column restraint	ISI AUG OWN PRE	-	-	-	-	-	s	-

**Southern Nuclear Operating Company
3rd Interval
VOGTLE-2 ISI PLAN, VERSION 3.0**

Category, Item No., Class	Summary No./CompID/System	Scope / Method / Procedure	Dwg/ISO No. Comp. Desc. Code Case		Period 1		Period 2		Period 3				
					2VR13	2VR14	2VR14A	2VR15	2VR16	2VR17	2VR18		
F-A F1.40(2) 3	V2 21202-P4-001-S09 21202-P4-001-S09 1202	ISI/VT/	2X4AF02-18,21 Column restraint	ISI AUG OWN PRE	-	-	-	-	-	s	-	-	-
F-A F1.40(2) 3	V2 21202-P4-001-S10 21202-P4-001-S10 1202	ISI/VT/	2X4AF02-18,21 Column restraint	ISI AUG OWN PRE	-	-	-	-	-	s	-	-	-
F-A F1.40(2) 3	V2 21202-P4-001-S11 21202-P4-001-S11 1202	ISI/VT/	2X4AF02-18,21 Column restraint	ISI AUG OWN PRE	-	-	-	-	-	s	-	-	-
F-A F1.40(2) 3	V2 21202-P4-001-S12 21202-P4-001-S12 1202	ISI/VT/	2X4AF02-18,21 Bowl restraint	ISI AUG OWN PRE	-	-	-	-	-	s	-	-	-
F-A F1.40(2) 3	V2 21202-P4-001-S13 21202-P4-001-S13 1202	ISI/VT/	2X4AF02-18,21 Bowl restraint	ISI AUG OWN PRE	-	-	-	-	-	s	-	-	-
F-A F1.40(2) 3	V2 21202-P4-001-S14 21202-P4-001-S14 1202	ISI/VT/	2X4AF02-18,21 Bowl restraint	ISI AUG OWN PRE	-	-	-	-	-	s	-	-	-
F-A F1.40(2) 3	V2 21202-P4-002-S01 21202-P4-002-S01 1202		2X4AF02-18,21 Disch Head Flange	ISI AUG OWN PRE	-	-	-	-	-	-	-	-	-
F-A F1.40(2) 3	V2 21202-P4-002-S02 21202-P4-002-S02 1202		2X4AF02-18,21 Column restraint	ISI AUG OWN PRE	-	-	-	-	-	-	-	-	-
F-A F1.40(2) 3	V2 21202-P4-002-S03 21202-P4-002-S03 1202		2X4AF02-18,21 Column restraint	ISI AUG OWN PRE	-	-	-	-	-	-	-	-	-
F-A F1.40(2) 3	V2 21202-P4-002-S04 21202-P4-002-S04 1202		2X4AF02-18,21 Column restraint	ISI AUG OWN PRE	-	-	-	-	-	-	-	-	-

Southern Nuclear Operating Company
3rd Interval
VOGTLE-2 ISI PLAN, VERSION 3.0

Category, Item No., Class	Summary No./ComplD/System	Scope / Method / Procedure	Dwg/ISO No. Comp. Desc. Code Case		Period 1		Period 2		Period 3			
					2VR13	2VR14	2VR14A	2VR15	2VR16	2VR17	2VR18	
F-A F1.40(2) 3	V2 21202-P4-002-S05 21202-P4-002-S05 1202		2X4AF02-18,21 Column restraint	ISI AUG OWN PRE	-	-	-	-	-	-	-	-
F-A F1.40(2) 3	V2 21202-P4-002-S06 21202-P4-002-S06 1202		2X4AF02-18,21 Column restraint	ISI AUG OWN PRE	-	-	-	-	-	-	-	-
F-A F1.40(2) 3	V2 21202-P4-002-S07 21202-P4-002-S07 1202		2X4AF02-18,21 Column restraint	ISI AUG OWN PRE	-	-	-	-	-	-	-	-
F-A F1.40(2) 3	V2 21202-P4-002-S08 21202-P4-002-S08 1202		2X4AF02-18,21 Column restraint	ISI AUG OWN PRE	-	-	-	-	-	-	-	-
F-A F1.40(2) 3	V2 21202-P4-002-S09 21202-P4-002-S09 1202		2X4AF02-18,21 Column restraint	ISI AUG OWN PRE	-	-	-	-	-	-	-	-
F-A F1.40(2) 3	V2 21202-P4-002-S10 21202-P4-002-S10 1202		2X4AF02-18,21 Column restraint	ISI AUG OWN PRE	-	-	-	-	-	-	-	-
F-A F1.40(2) 3	V2 21202-P4-002-S11 21202-P4-002-S11 1202		2X4AF02-18,21 Column restraint	ISI AUG OWN PRE	-	-	-	-	-	-	-	-
F-A F1.40(2) 3	V2 21202-P4-002-S12 21202-P4-002-S12 1202		2X4AF02-18,21 Bowl restraint	ISI AUG OWN PRE	-	-	-	-	-	-	-	-
F-A F1.40(2) 3	V2 21202-P4-002-S13 21202-P4-002-S13 1202		2X4AF02-18,21 Bowl restraint	ISI AUG OWN PRE	-	-	-	-	-	-	-	-
F-A F1.40(2) 3	V2 21202-P4-002-S14 21202-P4-002-S14 1202		2X4AF02-18,21 Bowl restraint	ISI AUG OWN PRE	-	-	-	-	-	-	-	-

Southern Nuclear Operating Company
3rd Interval
VOGTLE-2 ISI PLAN, VERSION 3.0

Category, Item No., Class	Summary No./ComplD/System	Scope / Method / Procedure	Dwg/ISO No. Comp. Desc. Code Case		Period 1		Period 2			Period 3	
					2VR13	2VR14	2VR14A	2VR15	2VR16	2VR17	2VR18
F-A	V2 21202-P4-003-S01		2X4AF02-18,21	ISI	-	-	-	-	-	-	-
F1.40(2)	21202-P4-003-S01		Disch Head Flange	AUG	-	-	-	-	-	-	-
3	1202			OWN	-	-	-	-	-	-	-
				PRE	-	-	-	-	-	-	-
F-A	V2 21202-P4-003-S02		2X4AF02-18,21	ISI	-	-	-	-	-	-	-
F1.40(2)	21202-P4-003-S02		Column restraint	AUG	-	-	-	-	-	-	-
3	1202			OWN	-	-	-	-	-	-	-
				PRE	-	-	-	-	-	-	-
F-A	V2 21202-P4-003-S03		2X4AF02-18,21	ISI	-	-	-	-	-	-	-
F1.40(2)	21202-P4-003-S03		Column restraint	AUG	-	-	-	-	-	-	-
3	1202			OWN	-	-	-	-	-	-	-
				PRE	-	-	-	-	-	-	-
F-A	V2 21202-P4-003-S04		2X4AF02-18,21	ISI	-	-	-	-	-	-	-
F1.40(2)	21202-P4-003-S04		Column restraint	AUG	-	-	-	-	-	-	-
3	1202			OWN	-	-	-	-	-	-	-
				PRE	-	-	-	-	-	-	-
F-A	V2 21202-P4-003-S05		2X4AF02-18,21	ISI	-	-	-	-	-	-	-
F1.40(2)	21202-P4-003-S05		Column restraint	AUG	-	-	-	-	-	-	-
3	1202			OWN	-	-	-	-	-	-	-
				PRE	-	-	-	-	-	-	-
F-A	V2 21202-P4-003-S06		2X4AF02-18,21	ISI	-	-	-	-	-	-	-
F1.40(2)	21202-P4-003-S06		Column restraint	AUG	-	-	-	-	-	-	-
3	1202			OWN	-	-	-	-	-	-	-
				PRE	-	-	-	-	-	-	-
F-A	V2 21202-P4-003-S07		2X4AF02-18,21	ISI	-	-	-	-	-	-	-
F1.40(2)	21202-P4-003-S07		Column restraint	AUG	-	-	-	-	-	-	-
3	1202			OWN	-	-	-	-	-	-	-
				PRE	-	-	-	-	-	-	-
F-A	V2 21202-P4-003-S08		2X4AF02-18,21	ISI	-	-	-	-	-	-	-
F1.40(2)	21202-P4-003-S08		Column restraint	AUG	-	-	-	-	-	-	-
3	1202			OWN	-	-	-	-	-	-	-
				PRE	-	-	-	-	-	-	-
F-A	V2 21202-P4-003-S09		2X4AF02-18,21	ISI	-	-	-	-	-	-	-
F1.40(2)	21202-P4-003-S09		Column restraint	AUG	-	-	-	-	-	-	-
3	1202			OWN	-	-	-	-	-	-	-
				PRE	-	-	-	-	-	-	-
F-A	V2 21202-P4-003-S10		2X4AF02-18,21	ISI	-	-	-	-	-	-	-
F1.40(2)	21202-P4-003-S10		Column restraint	AUG	-	-	-	-	-	-	-
3	1202			OWN	-	-	-	-	-	-	-
				PRE	-	-	-	-	-	-	-

Southern Nuclear Operating Company
3rd Interval
VOGTLE-2 ISI PLAN, VERSION 3.0

Category, Item No., Class	Summary No./ComplD/System	Scope / Method / Procedure	Dwg/ISO No. Comp. Desc. Code Case		Period 1		Period 2		Period 3	
					2VR13	2VR14	2VR14A	2VR15	2VR16	2VR17
F-A F1.40(2) 3	V2 21202-P4-003-S11 21202-P4-003-S11 1202		2X4AF02-18,21 Column restraint	ISI AUG OWN PRE	- - - -	- - - -	- - - -	- - - -	- - - -	- - - -
F-A F1.40(2) 3	V2 21202-P4-003-S12 21202-P4-003-S12 1202		2X4AF02-18,21 Bowl restraint	ISI AUG OWN PRE	- - - -	- - - -	- - - -	- - - -	- - - -	- - - -
F-A F1.40(2) 3	V2 21202-P4-003-S13 21202-P4-003-S13 1202		2X4AF02-18,21 Bowl restraint	ISI AUG OWN PRE	- - - -	- - - -	- - - -	- - - -	- - - -	- - - -
F-A F1.40(2) 3	V2 21202-P4-003-S14 21202-P4-003-S14 1202		2X4AF02-18,21 Bowl restraint	ISI AUG OWN PRE	- - - -	- - - -	- - - -	- - - -	- - - -	- - - -
F-A F1.40(2) 3	V2 21202-P4-004-S01 21202-P4-004-S01 1202		2X4AF02-18,21 Disch Head Flange	ISI AUG OWN PRE	- - - -	- - - -	- - - -	- - - -	- - - -	- - - -
F-A F1.40(2) 3	V2 21202-P4-004-S02 21202-P4-004-S02 1202		2X4AF02-18,21 Column restraint	ISI AUG OWN PRE	- - - -	- - - -	- - - -	- - - -	- - - -	- - - -
F-A F1.40(2) 3	V2 21202-P4-004-S03 21202-P4-004-S03 1202		2X4AF02-18,21 Column restraint	ISI AUG OWN PRE	- - - -	- - - -	- - - -	- - - -	- - - -	- - - -
F-A F1.40(2) 3	V2 21202-P4-004-S04 21202-P4-004-S04 1202		2X4AF02-18,21 Column restraint	ISI AUG OWN PRE	- - - -	- - - -	- - - -	- - - -	- - - -	- - - -
F-A F1.40(2) 3	V2 21202-P4-004-S05 21202-P4-004-S05 1202		2X4AF02-18,21 Column restraint	ISI AUG OWN PRE	- - - -	- - - -	- - - -	- - - -	- - - -	- - - -
F-A F1.40(2) 3	V2 21202-P4-004-S06 21202-P4-004-S06 1202		2X4AF02-18,21 Column restraint	ISI AUG OWN PRE	- - - -	- - - -	- - - -	- - - -	- - - -	- - - -

Southern Nuclear Operating Company
3rd Interval
VOGTLE-2 ISI PLAN, VERSION 3.0

Category, Item No., Class	Summary No./CompID/System	Scope / Method / Procedure	Dwg/ISO No. Comp. Desc. Code Case		Period 1		Period 2		Period 3	
					2VR13	2VR14	2VR14A	2VR15	2VR16	2VR17
F-A	V2 21202-P4-004-S07		2X4AF02-18,21	ISI	-	-	-	-	-	-
F1.40(2)	21202-P4-004-S07		Column restraint	AUG	-	-	-	-	-	-
3	1202			OWN	-	-	-	-	-	-
				PRE	-	-	-	-	-	-
F-A	V2 21202-P4-004-S08		2X4AF02-18,21	ISI	-	-	-	-	-	-
F1.40(2)	21202-P4-004-S08		Column restraint	AUG	-	-	-	-	-	-
3	1202			OWN	-	-	-	-	-	-
				PRE	-	-	-	-	-	-
F-A	V2 21202-P4-004-S09		2X4AF02-18,21	ISI	-	-	-	-	-	-
F1.40(2)	21202-P4-004-S09		Column restraint	AUG	-	-	-	-	-	-
3	1202			OWN	-	-	-	-	-	-
				PRE	-	-	-	-	-	-
F-A	V2 21202-P4-004-S10		2X4AF02-18,21	ISI	-	-	-	-	-	-
F1.40(2)	21202-P4-004-S10		Column restraint	AUG	-	-	-	-	-	-
3	1202			OWN	-	-	-	-	-	-
				PRE	-	-	-	-	-	-
F-A	V2 21202-P4-004-S11		2X4AF02-18,21	ISI	-	-	-	-	-	-
F1.40(2)	21202-P4-004-S11		Column restraint	AUG	-	-	-	-	-	-
3	1202			OWN	-	-	-	-	-	-
				PRE	-	-	-	-	-	-
F-A	V2 21202-P4-004-S12		2X4AF02-18,21	ISI	-	-	-	-	-	-
F1.40(2)	21202-P4-004-S12		Bowl restraint	AUG	-	-	-	-	-	-
3	1202			OWN	-	-	-	-	-	-
				PRE	-	-	-	-	-	-
F-A	V2 21202-P4-004-S13		2X4AF02-18,21	ISI	-	-	-	-	-	-
F1.40(2)	21202-P4-004-S13		Bowl restraint	AUG	-	-	-	-	-	-
3	1202			OWN	-	-	-	-	-	-
				PRE	-	-	-	-	-	-
F-A	V2 21202-P4-004-S14		2X4AF02-18,21	ISI	-	-	-	-	-	-
F1.40(2)	21202-P4-004-S14		Bowl restraint	AUG	-	-	-	-	-	-
3	1202			OWN	-	-	-	-	-	-
				PRE	-	-	-	-	-	-
F-A	V2 21202-P4-005-S01		2X4AF02-18,21	ISI	-	-	-	-	-	-
F1.40(2)	21202-P4-005-S01		Disch Head Flange	AUG	-	-	-	-	-	-
3	1202			OWN	-	-	-	-	-	-
				PRE	-	-	-	-	-	-
F-A	V2 21202-P4-005-S02		2X4AF02-18,21	ISI	-	-	-	-	-	-
F1.40(2)	21202-P4-005-S02		Column restraint	AUG	-	-	-	-	-	-
3	1202			OWN	-	-	-	-	-	-
				PRE	-	-	-	-	-	-

Southern Nuclear Operating Company
3rd Interval
VOGTLE-2 ISI PLAN, VERSION 3.0

Category, Item No., Class	Summary No./Compld/System	Scope / Method / Procedure	Dwg/ISO No. Comp. Desc. Code Case		Period 1		Period 2		Period 3	
					2VR13	2VR14	2VR14A	2VR15	2VR16	2VR17
F-A	V2 21202-P4-005-S03		2X4AF02-18,21	ISI	-	-	-	-	-	-
F1.40(2)	21202-P4-005-S03		Column restraint	AUG	-	-	-	-	-	-
3	1202			OWN	-	-	-	-	-	-
				PRE	-	-	-	-	-	-
F-A	V2 21202-P4-005-S04		2X4AF02-18,21	ISI	-	-	-	-	-	-
F1.40(2)	21202-P4-005-S04		Column restraint	AUG	-	-	-	-	-	-
3	1202			OWN	-	-	-	-	-	-
				PRE	-	-	-	-	-	-
F-A	V2 21202-P4-005-S05		2X4AF02-18,21	ISI	-	-	-	-	-	-
F1.40(2)	21202-P4-005-S05		Column restraint	AUG	-	-	-	-	-	-
3	1202			OWN	-	-	-	-	-	-
				PRE	-	-	-	-	-	-
F-A	V2 21202-P4-005-S06		2X4AF02-18,21	ISI	-	-	-	-	-	-
F1.40(2)	21202-P4-005-S06		Column restraint	AUG	-	-	-	-	-	-
3	1202			OWN	-	-	-	-	-	-
				PRE	-	-	-	-	-	-
F-A	V2 21202-P4-005-S07		2X4AF02-18,21	ISI	-	-	-	-	-	-
F1.40(2)	21202-P4-005-S07		Column restraint	AUG	-	-	-	-	-	-
3	1202			OWN	-	-	-	-	-	-
				PRE	-	-	-	-	-	-
F-A	V2 21202-P4-005-S08		2X4AF02-18,21	ISI	-	-	-	-	-	-
F1.40(2)	21202-P4-005-S08		Column restraint	AUG	-	-	-	-	-	-
3	1202			OWN	-	-	-	-	-	-
				PRE	-	-	-	-	-	-
F-A	V2 21202-P4-005-S09		2X4AF02-18,21	ISI	-	-	-	-	-	-
F1.40(2)	21202-P4-005-S09		Column restraint	AUG	-	-	-	-	-	-
3	1202			OWN	-	-	-	-	-	-
				PRE	-	-	-	-	-	-
F-A	V2 21202-P4-005-S10		2X4AF02-18,21	ISI	-	-	-	-	-	-
F1.40(2)	21202-P4-005-S10		Column restraint	AUG	-	-	-	-	-	-
3	1202			OWN	-	-	-	-	-	-
				PRE	-	-	-	-	-	-
F-A	V2 21202-P4-005-S11		2X4AF02-18,21	ISI	-	-	-	-	-	-
F1.40(2)	21202-P4-005-S11		Column restraint	AUG	-	-	-	-	-	-
3	1202			OWN	-	-	-	-	-	-
				PRE	-	-	-	-	-	-
F-A	V2 21202-P4-005-S12		2X4AF02-18,21	ISI	-	-	-	-	-	-
F1.40(2)	21202-P4-005-S12		Bowl restraint	AUG	-	-	-	-	-	-
3	1202			OWN	-	-	-	-	-	-
				PRE	-	-	-	-	-	-

Southern Nuclear Operating Company
3rd Interval
VOGTLE-2 ISI PLAN, VERSION 3.0

Category, Item No., Class	Summary No./ComplD/System	Scope / Method / Procedure	Dwg/ISO No. Comp. Desc. Code Case		Period 1		Period 2			Period 3	
					2VR13	2VR14	2VR14A	2VR15	2VR16	2VR17	2VR18
F-A	V2 21202-P4-005-S13		2X4AF02-18,21	ISI	-	-	-	-	-	-	-
F1.40(2)	21202-P4-005-S13		Bowl restraint	AUG	-	-	-	-	-	-	-
3	1202			OWN	-	-	-	-	-	-	-
				PRE	-	-	-	-	-	-	-
F-A	V2 21202-P4-005-S14		2X4AF02-18,21	ISI	-	-	-	-	-	-	-
F1.40(2)	21202-P4-005-S14		Bowl restraint	AUG	-	-	-	-	-	-	-
3	1202			OWN	-	-	-	-	-	-	-
				PRE	-	-	-	-	-	-	-
F-A	V2 21202-P4-006-S01		2X4AF02-18,21	ISI	-	-	-	-	-	-	-
F1.40(2)	21202-P4-006-S01		Disch Head Flange	AUG	-	-	-	-	-	-	-
3	1202			OWN	-	-	-	-	-	-	-
				PRE	-	-	-	-	-	-	-
F-A	V2 21202-P4-006-S02		2X4AF02-18,21	ISI	-	-	-	-	-	-	-
F1.40(2)	21202-P4-006-S02		Column restraint	AUG	-	-	-	-	-	-	-
3	1202			OWN	-	-	-	-	-	-	-
				PRE	-	-	-	-	-	-	-
F-A	V2 21202-P4-006-S03		2X4AF02-18,21	ISI	-	-	-	-	-	-	-
F1.40(2)	21202-P4-006-S03		Column restraint	AUG	-	-	-	-	-	-	-
3	1202			OWN	-	-	-	-	-	-	-
				PRE	-	-	-	-	-	-	-
F-A	V2 21202-P4-006-S04		2X4AF02-18,21	ISI	-	-	-	-	-	-	-
F1.40(2)	21202-P4-006-S04		Column restraint	AUG	-	-	-	-	-	-	-
3	1202			OWN	-	-	-	-	-	-	-
				PRE	-	-	-	-	-	-	-
F-A	V2 21202-P4-006-S05		2X4AF02-18,21	ISI	-	-	-	-	-	-	-
F1.40(2)	21202-P4-006-S05		Column restraint	AUG	-	-	-	-	-	-	-
3	1202			OWN	-	-	-	-	-	-	-
				PRE	-	-	-	-	-	-	-
F-A	V2 21202-P4-006-S06		2X4AF02-18,21	ISI	-	-	-	-	-	-	-
F1.40(2)	21202-P4-006-S06		Column restraint	AUG	-	-	-	-	-	-	-
3	1202			OWN	-	-	-	-	-	-	-
				PRE	-	-	-	-	-	-	-
F-A	V2 21202-P4-006-S07		2X4AF02-18,21	ISI	-	-	-	-	-	-	-
F1.40(2)	21202-P4-006-S07		Column restraint	AUG	-	-	-	-	-	-	-
3	1202			OWN	-	-	-	-	-	-	-
				PRE	-	-	-	-	-	-	-
F-A	V2 21202-P4-006-S08		2X4AF02-18,21	ISI	-	-	-	-	-	-	-
F1.40(2)	21202-P4-006-S08		Column restraint	AUG	-	-	-	-	-	-	-
3	1202			OWN	-	-	-	-	-	-	-
				PRE	-	-	-	-	-	-	-

Southern Nuclear Operating Company
3rd Interval
VOGTLE-2 ISI PLAN, VERSION 3.0

Category, Item No., Class	Summary No./ComplD/System	Scope / Method / Procedure	Dwg/ISO No. Comp. Desc. Code Case		Period 1		Period 2		Period 3	
					2VR13	2VR14	2VR14A	2VR15	2VR16	2VR17
F-A	V2 21202-P4-006-S09		2X4AF02-18,21	ISI	-	-	-	-	-	-
F1.40(2)	21202-P4-006-S09		Column restraint	AUG	-	-	-	-	-	-
3	1202			OWN	-	-	-	-	-	-
				PRE	-	-	-	-	-	-
F-A	V2 21202-P4-006-S10		2X4AF02-18,21	ISI	-	-	-	-	-	-
F1.40(2)	21202-P4-006-S10		Column restraint	AUG	-	-	-	-	-	-
3	1202			OWN	-	-	-	-	-	-
				PRE	-	-	-	-	-	-
F-A	V2 21202-P4-006-S11		2X4AF02-18,21	ISI	-	-	-	-	-	-
F1.40(2)	21202-P4-006-S11		Column restraint	AUG	-	-	-	-	-	-
3	1202			OWN	-	-	-	-	-	-
				PRE	-	-	-	-	-	-
F-A	V2 21202-P4-006-S12		2X4AF02-18,21	ISI	-	-	-	-	-	-
F1.40(2)	21202-P4-006-S12		Bowl restraint	AUG	-	-	-	-	-	-
3	1202			OWN	-	-	-	-	-	-
				PRE	-	-	-	-	-	-
F-A	V2 21202-P4-006-S13		2X4AF02-18,21	ISI	-	-	-	-	-	-
F1.40(2)	21202-P4-006-S13		Bowl restraint	AUG	-	-	-	-	-	-
3	1202			OWN	-	-	-	-	-	-
				PRE	-	-	-	-	-	-
F-A	V2 21202-P4-006-S14		2X4AF02-18,21	ISI	-	-	-	-	-	-
F1.40(2)	21202-P4-006-S14		Bowl restraint	AUG	-	-	-	-	-	-
3	1202			OWN	-	-	-	-	-	-
				PRE	-	-	-	-	-	-
F-A	V2 21202-P4-007-S01	ISI/VT/		ISI	-	-	-	-	s	-
F1.40(2)	21202-P4-007-S01		Dish Head Flange	AUG	-	-	-	-	-	-
3	1202			OWN	-	-	-	-	-	-
				PRE	-	-	-	-	-	-
F-A	V2 21202-P4-007-S02	ISI/VT/	2X4AF02-24,25	ISI	-	-	-	-	s	-
F1.40(2)	21202-P4-007-S02		Column restraint	AUG	-	-	-	-	-	-
3	1202			OWN	-	-	-	-	-	-
				PRE	-	-	-	-	-	-
F-A	V2 21202-P4-007-S03	ISI/VT/	2X4AF02-24,25	ISI	-	-	-	-	s	-
F1.40(2)	21202-P4-007-S03		Column restraint	AUG	-	-	-	-	-	-
3	1202			OWN	-	-	-	-	-	-
				PRE	-	-	-	-	-	-
F-A	V2 21202-P4-007-S04	ISI/VT/	2X4AF02-24,25	ISI	-	-	-	-	s	-
F1.40(2)	21202-P4-007-S04		Column restraint	AUG	-	-	-	-	-	-
3	1202			OWN	-	-	-	-	-	-
				PRE	-	-	-	-	-	-

Southern Nuclear Operating Company
3rd Interval
VOGTLE-2 ISI PLAN, VERSION 3.0

Category, Item No., Class	Summary No./ComplD/System	Scope / Method / Procedure	Dwg/ISO No. Comp. Desc. Code Case		Period 1		Period 2		Period 3					
					2VR13	2VR14	2VR14A	2VR15	2VR16	2VR17	2VR18			
F-A F1.40(2) 3	V2 21202-P4-007-S05 21202-P4-007-S05 1202	ISI/VT/	2X4AF02-24,25 Column restraint	ISI AUG OWN PRE	-	-	-	-	-	-	s	-	-	-
F-A F1.40(2) 3	V2 21202-P4-007-S06 21202-P4-007-S06 1202	ISI/VT/	2X4AF02-24,25 Column restraint	ISI AUG OWN PRE	-	-	-	-	-	-	s	-	-	-
F-A F1.40(2) 3	V2 21202-P4-007-S07 21202-P4-007-S07 1202	ISI/VT/	2X4AF02-24,25 Column restraint	ISI AUG OWN PRE	-	-	-	-	-	-	s	-	-	-
F-A F1.40(2) 3	V2 21202-P4-007-S08 21202-P4-007-S08 1202	ISI/VT/	2X4AF02-24,25 Column restraint	ISI AUG OWN PRE	-	-	-	-	-	-	s	-	-	-
F-A F1.40(2) 3	V2 21202-P4-007-S09 21202-P4-007-S09 1202	ISI/VT/	2X4AF02-24,25 Column restraint	ISI AUG OWN PRE	-	-	-	-	-	-	s	-	-	-
F-A F1.40(2) 3	V2 21202-P4-007-S10 21202-P4-007-S10 1202	ISI/VT/	2X4AF02-24,25 Column restraint	ISI AUG OWN PRE	-	-	-	-	-	-	s	-	-	-
F-A F1.40(2) 3	V2 21202-P4-007-S11 21202-P4-007-S11 1202	ISI/VT/	2X4AF02-24,25 Column restraint	ISI AUG OWN PRE	-	-	-	-	-	-	s	-	-	-
F-A F1.40(2) 3	V2 21202-P4-007-S12 21202-P4-007-S12 1202	ISI/VT/	2X4AF02-24,25 Column restraint	ISI AUG OWN PRE	-	-	-	-	-	-	s	-	-	-
F-A F1.40(2) 3	V2 21202-P4-007-S13 21202-P4-007-S13 1202	ISI/VT/	2X4AF02-24,25 Column restraint	ISI AUG OWN PRE	-	-	-	-	-	-	s	-	-	-
F-A F1.40(2) 3	V2 21202-P4-007-S14 21202-P4-007-S14 1202	ISI/VT/	2X4AF02-24,25 Column restraint	ISI AUG OWN PRE	-	-	-	-	-	-	s	-	-	-

Southern Nuclear Operating Company
3rd Interval
VOGTLE-2 ISI PLAN, VERSION 3.0

Category, Item No., Class	Summary No./ComplD/System	Scope / Method / Procedure	Dwg/ISO No. Comp. Desc. Code Case		Period 1		Period 2		Period 3					
					2VR13	2VR14	2VR14A	2VR15	2VR16	2VR17	2VR18			
F-A F1.40(2) 3	V2 21202-P4-007-S15 21202-P4-007-S15 1202	ISI/VT/	2X4AF02-24,25 Column restraint	ISI AUG OWN PRE	-	-	-	-	-	s	-	-	-	-
F-A F1.40(2) 3	V2 21202-P4-007-S16 21202-P4-007-S16 1202	ISI/VT/	2X4AF02-24,25 Bowl restraint	ISI AUG OWN PRE	-	-	-	-	-	s	-	-	-	-
F-A F1.40(2) 3	V2 21202-P4-007-S17 21202-P4-007-S17 1202	ISI/VT/	2X4AF02-24,25 Bowl restraint	ISI AUG OWN PRE	-	-	-	-	-	s	-	-	-	-
F-A F1.40(2) 3	V2 21202-P4-007-S18 21202-P4-007-S18 1202	ISI/VT/	2X4AF02-24,25 Bowl restraint	ISI AUG OWN PRE	-	-	-	-	-	s	-	-	-	-
F-A F1.40(2) 3	V2 21202-P4-008-S01 21202-P4-008-S01 1202		Disch Head Flange	ISI AUG OWN PRE	-	-	-	-	-	-	-	-	-	-
F-A F1.40(2) 3	V2 21202-P4-008-S02 21202-P4-008-S02 1202		2X4AF02-24,25 Column restraint	ISI AUG OWN PRE	-	-	-	-	-	-	-	-	-	-
F-A F1.40(2) 3	V2 21202-P4-008-S03 21202-P4-008-S03 1202		2X4AF02-24,25 Column restraint	ISI AUG OWN PRE	-	-	-	-	-	-	-	-	-	-
F-A F1.40(2) 3	V2 21202-P4-008-S04 21202-P4-008-S04 1202		2X4AF02-24,25 Column restraint	ISI AUG OWN PRE	-	-	-	-	-	-	-	-	-	-
F-A F1.40(2) 3	V2 21202-P4-008-S05 21202-P4-008-S05 1202		2X4AF02-24,25 Column restraint	ISI AUG OWN PRE	-	-	-	-	-	-	-	-	-	-
F-A F1.40(2) 3	V2 21202-P4-008-S06 21202-P4-008-S06 1202		2X4AF02-24,25 Column restraint	ISI AUG OWN PRE	-	-	-	-	-	-	-	-	-	-

Southern Nuclear Operating Company
3rd Interval
VOGTLE-2 ISI PLAN, VERSION 3.0

Category, Item No., Class	Summary No./ComplD/System	Scope / Method / Procedure	Dwg/ISO No. Comp. Desc. Code Case		Period 1		Period 2			Period 3	
					2VR13	2VR14	2VR14A	2VR15	2VR16	2VR17	2VR18
F-A	V2 21202-P4-008-S07		2X4AF02-24,25	ISI	-	-	-	-	-	-	-
F1.40(2)	21202-P4-008-S07		Column restraint	AUG	-	-	-	-	-	-	-
3	1202			OWN	-	-	-	-	-	-	-
				PRE	-	-	-	-	-	-	-
F-A	V2 21202-P4-008-S08		2X4AF02-24,25	ISI	-	-	-	-	-	-	-
F1.40(2)	21202-P4-008-S08		Column restraint	AUG	-	-	-	-	-	-	-
3	1202			OWN	-	-	-	-	-	-	-
				PRE	-	-	-	-	-	-	-
F-A	V2 21202-P4-008-S09		2X4AF02-24,25	ISI	-	-	-	-	-	-	-
F1.40(2)	21202-P4-008-S09		Column restraint	AUG	-	-	-	-	-	-	-
3	1202			OWN	-	-	-	-	-	-	-
				PRE	-	-	-	-	-	-	-
F-A	V2 21202-P4-008-S10		2X4AF02-24,25	ISI	-	-	-	-	-	-	-
F1.40(2)	21202-P4-008-S10		Column restraint	AUG	-	-	-	-	-	-	-
3	1202			OWN	-	-	-	-	-	-	-
				PRE	-	-	-	-	-	-	-
F-A	V2 21202-P4-008-S11		2X4AF02-24,25	ISI	-	-	-	-	-	-	-
F1.40(2)	21202-P4-008-S11		Column restraint	AUG	-	-	-	-	-	-	-
3	1202			OWN	-	-	-	-	-	-	-
				PRE	-	-	-	-	-	-	-
F-A	V2 21202-P4-008-S12		2X4AF02-24,25	ISI	-	-	-	-	-	-	-
F1.40(2)	21202-P4-008-S12		Column restraint	AUG	-	-	-	-	-	-	-
3	1202			OWN	-	-	-	-	-	-	-
				PRE	-	-	-	-	-	-	-
F-A	V2 21202-P4-008-S13		2X4AF02-24,25	ISI	-	-	-	-	-	-	-
F1.40(2)	21202-P4-008-S13		Column restraint	AUG	-	-	-	-	-	-	-
3	1202			OWN	-	-	-	-	-	-	-
				PRE	-	-	-	-	-	-	-
F-A	V2 21202-P4-008-S14		2X4AF02-24,25	ISI	-	-	-	-	-	-	-
F1.40(2)	21202-P4-008-S14		Column restraint	AUG	-	-	-	-	-	-	-
3	1202			OWN	-	-	-	-	-	-	-
				PRE	-	-	-	-	-	-	-
F-A	V2 21202-P4-008-S15		2X4AF02-24,25	ISI	-	-	-	-	-	-	-
F1.40(2)	21202-P4-008-S15		Column restraint	AUG	-	-	-	-	-	-	-
3	1202			OWN	-	-	-	-	-	-	-
				PRE	-	-	-	-	-	-	-
F-A	V2 21202-P4-008-S16		2X4AF02-24,25	ISI	-	-	-	-	-	-	-
F1.40(2)	21202-P4-008-S16		Bowl restraint	AUG	-	-	-	-	-	-	-
3	1202			OWN	-	-	-	-	-	-	-
				PRE	-	-	-	-	-	-	-

Southern Nuclear Operating Company
3rd Interval
VOGTLE-2 ISI PLAN, VERSION 3.0

Category, Item No., Class	Summary No./ComplID/System	Scope / Method / Procedure	Dwg/ISO No. Comp. Desc. Code Case		Period 1		Period 2		Period 3	
					2VR13	2VR14	2VR14A	2VR15	2VR16	2VR17
F-A	V2 21202-P4-008-S17		2X4AF02-24,25	ISI	-	-	-	-	-	-
F1.40(2)	21202-P4-008-S17		Bowl restraint	AUG	-	-	-	-	-	-
3	1202			OWN	-	-	-	-	-	-
				PRE	-	-	-	-	-	-
F-A	V2 21202-P4-008-S18		2X4AF02-24,25	ISI	-	-	-	-	-	-
F1.40(2)	21202-P4-008-S18		Bowl restraint	AUG	-	-	-	-	-	-
3	1202			OWN	-	-	-	-	-	-
				PRE	-	-	-	-	-	-
F-A	V2 21203-E4-001-S01	ISI/VT/		ISI	-	-	-	-	s	-
F1.40(2)	21203-E4-001-S01		HE support	AUG	-	-	-	-	-	-
3	1203			OWN	-	-	-	-	-	-
				PRE	-	-	-	-	-	-
F-A	V2 21203-E4-001-S02	ISI/VT/	2X4AE01-51	ISI	-	-	-	-	s	-
F1.40(2)	21203-E4-001-S02		HE support	AUG	-	-	-	-	-	-
3	1203			OWN	-	-	-	-	-	-
				PRE	-	-	-	-	-	-
F-A	V2 21203-E4-002-S01		2X4AE01-51	ISI	-	-	-	-	-	-
F1.40(2)	21203-E4-002-S01		HE support	AUG	-	-	-	-	-	-
3	1203			OWN	-	-	-	-	-	-
				PRE	-	-	-	-	-	-
F-A	V2 21203-E4-002-S02		2X4AE01-51	ISI	-	-	-	-	-	-
F1.40(2)	21203-E4-002-S02		HE support	AUG	-	-	-	-	-	-
3	1203			OWN	-	-	-	-	-	-
				PRE	-	-	-	-	-	-
F-A	V2 21203-P4-001-S01	ISI/VT/	2X4AF01-67	ISI	-	-	s	-	-	-
F1.40(2)	21203-P4-001-S01		Pump support	AUG	-	-	-	-	-	-
3	1203			OWN	-	-	-	-	-	-
				PRE	-	-	-	-	-	-
F-A	V2 21203-P4-001-S02	ISI/VT/	2X4AF01-67	ISI	-	-	s	-	-	-
F1.40(2)	21203-P4-001-S02		Pump support	AUG	-	-	-	-	-	-
3	1203			OWN	-	-	-	-	-	-
				PRE	-	-	-	-	-	-
F-A	V2 21203-P4-002-S01		2X4AF01-70	ISI	-	-	-	-	-	-
F1.40(2)	21203-P4-002-S01		Pump support	AUG	-	-	-	-	-	-
3	1203			OWN	-	-	-	-	-	-
				PRE	-	-	-	-	-	-
F-A	V2 21203-P4-002-S02		2X4AF01-70	ISI	-	-	-	-	-	-
F1.40(2)	21203-P4-002-S02		Pump support	AUG	-	-	-	-	-	-
3	1203			OWN	-	-	-	-	-	-
				PRE	-	-	-	-	-	-

Southern Nuclear Operating Company
3rd Interval
VOGTLE-2 ISI PLAN, VERSION 3.0

Category, Item No., Class	Summary No./ComplD/System	Scope / Method / Procedure	Dwg/ISO No. Comp. Desc. Code Case		Period 1		Period 2		Period 3	
					2VR13	2VR14	2VR14A	2VR15	2VR16	2VR17
F-A	V2 21203-P4-003-S01		2X4AF01-67	ISI	-	-	-	-	-	-
F1.40(2)	21203-P4-003-S01		Pump support	AUG	-	-	-	-	-	-
3	1203			OWN	-	-	-	-	-	-
				PRE	-	-	-	-	-	-
F-A	V2 21203-P4-003-S02		2X4AF01-67	ISI	-	-	-	-	-	-
F1.40(2)	21203-P4-003-S02		Pump support	AUG	-	-	-	-	-	-
3	1203			OWN	-	-	-	-	-	-
				PRE	-	-	-	-	-	-
F-A	V2 21203-P4-004-S01		2X4AF01-70	ISI	-	-	-	-	-	-
F1.40(2)	21203-P4-004-S01		Pump support	AUG	-	-	-	-	-	-
3	1203			OWN	-	-	-	-	-	-
				PRE	-	-	-	-	-	-
F-A	V2 21203-P4-004-S02		2X4AF01-70	ISI	-	-	-	-	-	-
F1.40(2)	21203-P4-004-S02		Pump support	AUG	-	-	-	-	-	-
3	1203			OWN	-	-	-	-	-	-
				PRE	-	-	-	-	-	-
F-A	V2 21203-P4-005-S01		2X4AF01-67	ISI	-	-	-	-	-	-
F1.40(2)	21203-P4-005-S01		Pump support	AUG	-	-	-	-	-	-
3	1203			OWN	-	-	-	-	-	-
				PRE	-	-	-	-	-	-
F-A	V2 21203-P4-005-S02		2X4AF01-67	ISI	-	-	-	-	-	-
F1.40(2)	21203-P4-005-S02		Pump support	AUG	-	-	-	-	-	-
3	1203			OWN	-	-	-	-	-	-
				PRE	-	-	-	-	-	-
F-A	V2 21203-P4-006-S01		2X4AF01-70	ISI	-	-	-	-	-	-
F1.40(2)	21203-P4-006-S01		Pump support	AUG	-	-	-	-	-	-
3	1203			OWN	-	-	-	-	-	-
				PRE	-	-	-	-	-	-
F-A	V2 21203-P4-006-S02		2X4AF01-70	ISI	-	-	-	-	-	-
F1.40(2)	21203-P4-006-S02		Pump support	AUG	-	-	-	-	-	-
3	1203			OWN	-	-	-	-	-	-
				PRE	-	-	-	-	-	-
F-A	V2 21203-T4-001-S01		2X4AH04-2	ISI	-	-	-	-	-	-
F1.40(2)	21203-T4-001-S01		Tank support	AUG	-	-	-	-	-	-
3	1203			OWN	-	-	-	-	-	-
				PRE	-	-	-	-	-	-
F-A	V2 21203-T4-001-S02		2X4AH04-2	ISI	-	-	-	-	-	-
F1.40(2)	21203-T4-001-S02		Tank support	AUG	-	-	-	-	-	-
3	1203			OWN	-	-	-	-	-	-
				PRE	-	-	-	-	-	-

Southern Nuclear Operating Company
3rd Interval
VOGTLE-2 ISI PLAN, VERSION 3.0

Category, Item No., Class	Summary No./ComplD/System	Scope / Method / Procedure	Dwg/ISO No. Comp. Desc. Code Case		Period 1		Period 2		Period 3		
					2VR13	2VR14	2VR14A	2VR15	2VR16	2VR17	2VR18
F-A	V2 21203-T4-002-S01	ISI/VT/	2X4AH04-2	ISI	-	-	-	-	-	s	-
F1.40(2)	21203-T4-002-S01		Tank support	AUG	-	-	-	-	-	-	-
3	1203			OWN	-	-	-	-	-	-	-
				PRE	-	-	-	-	-	-	-
F-A	V2 21203-T4-002-S02	ISI/VT/		ISI	-	-	-	-	-	s	-
F1.40(2)	21203-T4-002-S02		Tank support	AUG	-	-	-	-	-	-	-
3	1203			OWN	-	-	-	-	-	-	-
				PRE	-	-	-	-	-	-	-
F-A	V2 21204-P6-003-S01		2X6AG02-10	ISI	-	-	-	-	-	-	-
F1.40(2)	21204-P6-003-S01		Pump support	AUG	-	-	-	-	-	-	-
2	1204			OWN	-	-	-	-	-	-	-
				PRE	-	-	-	-	-	-	-
F-A	V2 21204-P6-004-S01	ISI/VT/	2X6AG02-10	ISI	-	-	-	s	-	-	-
F1.40(2)	21204-P6-004-S01		Pump support	AUG	-	-	-	-	-	-	-
2	1204			OWN	-	-	-	-	-	-	-
				PRE	-	-	-	-	-	-	-
F-A	V2 21205-E6-001-S01		2X6AF03-8	ISI	-	-	-	-	-	-	-
F1.40(2)	21205-E6-001-S01		Support skirt	AUG	-	-	-	-	-	-	-
2	1205			OWN	-	-	-	-	-	-	-
				PRE	-	-	-	-	-	-	-
F-A	V2 21205-E6-001-S02		2X6AF03-8	ISI	-	-	-	-	-	-	-
F1.40(2)	21205-E6-001-S02		Seismic restraint	AUG	-	-	-	-	-	-	-
3	1205			OWN	-	-	-	-	-	-	-
				PRE	-	-	-	-	-	-	-
F-A	V2 21205-E6-002-S01	ISI/VT/	2X6AF03-8	ISI	-	-	-	s	-	-	-
F1.40(2)	21205-E6-002-S01		Support skirt	AUG	-	-	-	-	-	-	-
2	1205			OWN	-	-	-	-	-	-	-
				PRE	-	-	-	-	-	-	-
F-A	V2 21205-E6-002-S02	ISI/VT/		ISI	-	-	-	-	-	s	-
F1.40(2)	21205-E6-002-S02		Seismic restraint	AUG	-	-	-	-	-	-	-
3	1205			OWN	-	-	-	-	-	-	-
				PRE	-	-	-	-	-	-	-
F-A	V2 21205-P6-001-SP01		2X6AF02-26	ISI	-	-	-	-	-	-	-
F1.40(2)	21205-P6-001-SP01		Pump support	AUG	-	-	-	-	-	-	-
2	1205			OWN	-	-	-	-	-	-	-
				PRE	-	-	-	-	-	-	-
F-A	V2 21205-P6-001-SP02		2X6AF02-26	ISI	-	-	-	-	-	-	-
F1.40(2)	21205-P6-001-SP02		Pump support	AUG	-	-	-	-	-	-	-
2	1205			OWN	-	-	-	-	-	-	-
				PRE	-	-	-	-	-	-	-

**Southern Nuclear Operating Company
3rd Interval
VOGTLE-2 ISI PLAN, VERSION 3.0**

Category, Item No., Class	Summary No./CompID/System	Scope / Method / Procedure	Dwg/ISO No. Comp. Desc. Code Case		Period 1		Period 2		Period 3		
					2VR13	2VR14	2VR14A	2VR15	2VR16	2VR17	2VR18
F-A F1.40(2) 2	V2 21205-P6-001-SP03 21205-P6-001-SP03 1205		2X6AF02-26 Pump support	ISI AUG OWN PRE	-	-	-	-	-	-	-
F-A F1.40(2) 2	V2 21205-P6-002-SP01 21205-P6-002-SP01 1205	ISI/VT/NMP-ES-024-203	2X6AF02-26 Pump support	ISI AUG OWN PRE	c	-	-	-	-	-	-
F-A F1.40(2) 2	V2 21205-P6-002-SP02 21205-P6-002-SP02 1205	ISI/VT/NMP-ES-024-203	2X6AF02-26 Pump support	ISI AUG OWN PRE	c	-	-	-	-	-	-
F-A F1.40(2) 2	V2 21205-P6-002-SP03 21205-P6-002-SP03 1205	ISI/VT/NMP-ES-024-203	2X6AF02-26 Pump support	ISI AUG OWN PRE	c	-	-	-	-	-	-
F-A F1.40(2) 2	V2 21208-E6-001-S01 21208-E6-001-S01 1208	ISI/VT/	2X6AA00-112 Heat exchanger	ISI AUG OWN PRE	-	-	-	-	-	s	-
F-A F1.40(2) 2	V2 21208-E6-001-S02 21208-E6-001-S02 1208	ISI/VT/	2X6AA00-112 Heat exchanger	ISI AUG OWN PRE	-	-	-	-	-	s	-
F-A F1.40(2) 2	V2 21208-E6-001-S03 21208-E6-001-S03 1208	ISI/VT/	2X6AA00-112 Heat exchanger	ISI AUG OWN PRE	-	-	-	-	-	s	-
F-A F1.40(2) 3	V2 21208-F6-003-S01 21208-F6-003-S01 1208	ISI/VT/NMP-ES-024-203	Filter support	ISI AUG OWN PRE	c	-	-	-	-	-	-
F-A F1.40(2) 2	V2 21208-P6-002-S01 21208-P6-002-S01 1208		2X6AH02-65 Support base	ISI AUG OWN PRE	-	-	-	-	-	-	-
F-A F1.40(2) 2	V2 21208-P6-003-S01 21208-P6-003-S01 1208	ISI/VT/	2X6AH02-65 Support base	ISI AUG OWN PRE	-	-	-	s	-	-	-

Southern Nuclear Operating Company
3rd Interval
VOGTLE-2 ISI PLAN, VERSION 3.0

Category, Item No., Class	Summary No./ComplD/System	Scope / Method / Procedure	Dwg/ISO No. Comp. Desc. Code Case		Period 1		Period 2		Period 3		
					2VR13	2VR14	2VR14A	2VR15	2VR16	2VR17	2VR18
F-A	V2 21208-P6-006-S01	ISI/VT/	2X6AH02-45	ISI	-	-	-	-	s	-	-
F1.40(2)	21208-P6-006-S01		Pump support	AUG	-	-	-	-	-	-	-
3	1208			OWN	-	-	-	-	-	-	-
				PRE	-	-	-	-	-	-	-
F-A	V2 21208-P6-007-S01		2X6AH02-45	ISI	-	-	-	-	-	-	-
F1.40(2)	21208-P6-007-S01		Pump support	AUG	-	-	-	-	-	-	-
3	1208			OWN	-	-	-	-	-	-	-
				PRE	-	-	-	-	-	-	-
F-A	V2 21213-E6-001-S01	ISI/VT/NMP-ES-024-203		ISI	c	-	-	-	-	-	-
F1.40(2)	21213-E6-001-S01		HE support	AUG	-	-	-	-	-	-	-
3	1213			OWN	-	-	-	-	-	-	-
				PRE	-	-	-	-	-	-	-
F-A	V2 21213-E6-001-S02	ISI/VT/NMP-ES-024-203	2X6AM06-5	ISI	c	-	-	-	-	-	-
F1.40(2)	21213-E6-001-S02		HE support	AUG	-	-	-	-	-	-	-
3	1213			OWN	-	-	-	-	-	-	-
				PRE	-	-	-	-	-	-	-
F-A	V2 21213-E6-002-S01		2X6AM06-5	ISI	-	-	-	-	-	-	-
F1.40(2)	21213-E6-002-S01		HE support	AUG	-	-	-	-	-	-	-
3	1213			OWN	-	-	-	-	-	-	-
				PRE	-	-	-	-	-	-	-
F-A	V2 21213-E6-002-S02		2X6AM06-5	ISI	-	-	-	-	-	-	-
F1.40(2)	21213-E6-002-S02		HE support	AUG	-	-	-	-	-	-	-
3	1213			OWN	-	-	-	-	-	-	-
				PRE	-	-	-	-	-	-	-
F-A	V2 21213-P6-002-S01		2X6AM03-6	ISI	-	-	-	-	-	-	-
F1.40(2)	21213-P6-002-S01		Pump support	AUG	-	-	-	-	-	-	-
3	1213			OWN	-	-	-	-	-	-	-
				PRE	-	-	-	-	-	-	-
F-A	V2 21213-P6-002-S02		2X6AM03-6	ISI	-	-	-	-	-	-	-
F1.40(2)	21213-P6-002-S02		Pump support	AUG	-	-	-	-	-	-	-
3	1213			OWN	-	-	-	-	-	-	-
				PRE	-	-	-	-	-	-	-
F-A	V2 21213-P6-005-S01	ISI/VT/	2X6AM03-6	ISI	-	-	-	s	-	-	-
F1.40(2)	21213-P6-005-S01		Pump support	AUG	-	-	-	-	-	-	-
3	1213			OWN	-	-	-	-	-	-	-
				PRE	-	-	-	-	-	-	-
F-A	V2 21213-P6-005-S02	ISI/VT/	2X6AM03-6	ISI	-	-	-	s	-	-	-
F1.40(2)	21213-P6-005-S02		Pump support	AUG	-	-	-	-	-	-	-
3	1213			OWN	-	-	-	-	-	-	-
				PRE	-	-	-	-	-	-	-

Southern Nuclear Operating Company
3rd Interval
VOGTLE-2 ISI PLAN, VERSION 3.0

Category, Item No., Class	Summary No./CompID/System	Scope / Method / Procedure	Dwg/ISO No. Comp. Desc. Code Case		Period 1		Period 2		Period 3		
					2VR13	2VR14	2VR14A	2VR15	2VR16	2VR17	2VR18
F-A F1.40(2) 3	V2 21302-P4-001-S01 21302-P4-001-S01 1302	ISI/VT/NMP-ES-024-203	2X4AF03-83 PUMP SUPPORT	ISI AUG OWN PRE	c	-	-	-	-	-	-
F-A F1.40(2) 3	V2 21302-P4-002-S01 21302-P4-002-S01 1302		2X4AF03-81 PUMP SUPPORT	ISI AUG OWN PRE	-	-	-	-	-	-	-
F-A F1.40(2) 3	V2 21302-P4-003-S01 21302-P4-003-S01 1302	ISI/VT/	2X4AF03-81 PUMP SUPPORT	ISI AUG OWN PRE	-	-	-	-	-	s	-
F-A F1.40(2) 3	V2 21592-P7-001-S01 21592-P7-001-S01 1592	ISI/VT/	2X4AJ05-027 Pump support	ISI AUG OWN PRE	-	-	s	-	-	-	-
F-A F1.40(2) 3	V2 21592-P7-001-S02 21592-P7-001-S02 1592	ISI/VT/	2X4AJ05-027 Pump support	ISI AUG OWN PRE	-	-	s	-	-	-	-
F-A F1.40(2) 3	V2 21592-P7-002-S01 21592-P7-002-S01 1592		2X4AJ05-027 Pump support	ISI AUG OWN PRE	-	-	-	-	-	-	-
F-A F1.40(2) 3	V2 21592-P7-002-S02 21592-P7-002-S02 1592		2X4AJ05-027 Pump support	ISI AUG OWN PRE	-	-	-	-	-	-	-
F-A F1.40(2) 3	V2 21592-T7-001-S01 21592-T7-001-S01 1592		2X4AH04-63 Tank support	ISI AUG OWN PRE	-	-	-	-	-	-	-
F-A F1.40(2) 3	V2 21592-T7-001-S02 21592-T7-001-S02 1592		2X4AH04-63 Tank support	ISI AUG OWN PRE	-	-	-	-	-	-	-
F-A F1.40(2) 3	V2 21592-T7-002-S01 21592-T7-002-S01 1592	ISI/VT/	2X4AH04-63 Tank support	ISI AUG OWN PRE	-	-	s	-	-	-	-

Southern Nuclear Operating Company
3rd Interval
VOGTLE-2 ISI PLAN, VERSION 3.0

Category, Item No., Class	Summary No./CompID/System	Scope / Method / Procedure	Dwg/ISO No. Comp. Desc. Code Case		Period 1		Period 2		Period 3	
					2VR13	2VR14	2VR14A	2VR15	2VR16	2VR17
F-A F1.40(2) 3	V2 21592-T7-002-S02 21592-T7-002-S02 1592	ISI/VT/	Tank support	ISI AUG OWN PRE	- - - -	- - - -	- - - -	- - - -	- - - -	- - - -
F-A F1.40S 2	V2 21201-B6-001-S06 21201-B6-001-S06 1201	ISI/VT/	ISI-21201-B6-001 2X6AB18-15 HYD SNUBBER	ISI AUG OWN PRE	- - - -	- - - -	- - - -	- - - -	- - - -	s - - -
F-A F1.40S 2	V2 21201-B6-001-S08 21201-B6-001-S08 1201	ISI/VT/	ISI-21201-B6-001 2X6AB18-15 HYD SNUBBER	ISI AUG OWN PRE	- - - -	- - - -	- - - -	- - - -	- - - -	s - - -
F-A F1.40S 2	V2 21201-B6-002-S06 21201-B6-002-S06 1201		ISI-21201-B6-002 2X6AB18-15 HYD SNUBBER	ISI AUG OWN PRE	- - - -	- - - -	- - - -	- - - -	- - - -	- - - -
F-A F1.40S 2	V2 21201-B6-002-S08 21201-B6-002-S08 1201		ISI-21201-B6-002 2X6AB18-15 HYD SNUBBER	ISI AUG OWN PRE	- - - -	- - - -	- - - -	- - - -	- - - -	- - - -
F-A F1.40S 2	V2 21201-B6-003-S06 21201-B6-003-S06 1201		ISI-21201-B6-003 2X6AB18-15 HYD SNUBBER	ISI AUG OWN PRE	- - - -	- - - -	- - - -	- - - -	- - - -	- - - -
F-A F1.40S 2	V2 21201-B6-003-S08 21201-B6-003-S08 1201		ISI-21201-B6-003 2X6AB18-15 HYD SNUBBER	ISI AUG OWN PRE	- - - -	- - - -	- - - -	- - - -	- - - -	- - - -
F-A F1.40S 2	V2 21201-B6-004-S06 21201-B6-004-S06 1201		ISI-21201-B6-004 2X6AB18-15 HYD SNUBBER	ISI AUG OWN PRE	- - - -	- - - -	- - - -	- - - -	- - - -	- - - -
F-A F1.40S 2	V2 21201-B6-004-S08 21201-B6-004-S08 1201		ISI-21201-B6-004 2X6AB18-15 HYD SNUBBER	ISI AUG OWN PRE	- - - -	- - - -	- - - -	- - - -	- - - -	- - - -

**VOGTLE UNIT 2 THIRD INTERVAL ISI PLAN
CLASS 1 AND 2 PIPING**

CLASS 1 PIPING EXAMINATION REQUIREMENTS

The examination requirements for the Class 1 components identified on the P&IDs are defined in IWB-2500 for each examination category. Categories in the 2001 Edition of Section XI with Addenda through 2003 for piping are:

- Category B-F Pressure Retaining Dissimilar Metal Welds
- Category B-J Pressure Retaining Welds in Piping

EXEMPTIONS

IWB-1220 defines the components that are exempt from the examination requirements of IWB-2500.

DEVIATIONS TO CLASS 1 ISI CODE REQUIREMENTS

IWB-2500 provides the examination requirements for Class 1 components. These Code requirements may be deviated from by:

- The use of NRC approved alternatives per 10 CFR 50.55a(a)(3).
- The use of NRC approved Relief Requests per 10 CFR 50.55a(g)(6) when an examination requirement by the Code is determined to be impractical.
- The use of Code Cases approved for use by the NRC through publication in Regulatory Guide 1.147.

Significant deviations from IWB-2500 Code requirements at VEGP include Code Cases, Relief Requests, Alternatives, and NRC Safety Evaluations as shown in Volume 1.

One specific deviation is that in lieu of performing surface examinations on examination Category B-F (NPS 4 and larger) and B-J (NPS 4 and larger surface), Code Case N-663 was used to eliminate the examinations except for those areas identified by SNC as susceptible to outside surface attack. No Class 1 welds are considered susceptible to outside surface attack because any non-metallic insulation complies with Regulatory Guide 1.36, and the plant specific chemical controls should prevent the outside contamination of the subject piping welds with chlorides, fluorides, etc. Additionally, Code Case N-624 was used, in some cases, to modify the sequence of examinations; however, the percentage requirements of Table IWB-2412-1 were met.

Category B-F – Item B5.10 and B5.70 Dissimilar Metal Welds

During a portion of the 2nd Interval, Category B-F welds were examined per the requirements of Section XI. By a September 30, 2003 NRC Safety Evaluation, the NRC approved a Risk-Informed ISI Program as an alternative for examination of Category B-F and other piping welds. Subsequent 2nd Interval piping weld examinations were then performed per this Risk-Informed Program. A Risk-Informed ISI Program has not been approved for the 3rd Interval; therefore, the requirements of Section XI will be satisfied.

**VOGTLE UNIT 2 THIRD INTERVAL ISI PLAN
CLASS 1 AND 2 PIPING**

There are eight Item B5.10 Alloy 82/182 RPV dissimilar metal welds. Per Footnote 2 of Table IWB-2500-1, the examinations are deferrable to the end of the interval because no repair/replacement activities have been performed on these welds, and there are no flaws or relevant conditions requiring successive inspections in accordance with IWB-2420(b).

There are eight Item B5.70 stainless steel steam generator dissimilar metal welds. The examinations are not deferrable to the end of the interval.

The six Item B5.40 Alloy 82/182 pressurizer dissimilar metal welds have been overlaid. (See overlay examinations in the Augmented Section of this plan).

Category B-J – Item B9.11, B9.21, B9.22, B9.31, B9.32 and B9.40 Pressure Retaining Welds

During a portion of the 2nd Interval, Category B-J welds were examined per the requirements of Section XI. By a September 30, 2003 NRC Safety Evaluation, the NRC approved a Risk-Informed ISI Program as an alternative for examination of Category B-J and other piping welds. Subsequent 2nd Interval piping weld examinations were then performed per this Risk-Informed Program. A Risk-Informed ISI Program has not been approved for the 3rd Interval; therefore, the requirements of Section XI will be satisfied.

As an alternative to the weld selection requirements of Table IWB-2500-1, Category B-J, Footnote 1, NRC approved Code Case N-609 will be used to select the welds requiring examination. As another alternative, Code Case N-624 will be used for the scheduling. The requirements for implementing Code Case N-609 and the resulting weld selections welds for Vogtle Unit 2 are discussed below.

1. The first step is to select all of terminal ends in each pipe or branch run connected to *vessels*. The only vessels in the scope are the RPV, the four Steam Generators, and the pressurizer. The Pressurizer Category B-J terminal end welds were overlaid with the dissimilar metal welds; therefore, they are not in this scope. Additionally, the terminal end welds attaching the Reactor Coolant piping to the Steam Generator nozzles are classified as Category B-F; therefore, they are not in this scope. The eight RPV welds are shown below.

Weld	Size	Description
21201-001-1	29"	RPV Safe End To HL Pipe
21201-002-1	29"	RPV Safe End To HL Pipe
21201-003-1	29"	RPV Safe End To HL Pipe
21201-004-1	29"	RPV Safe End To HL Pipe
21201-009-9	27.5"	CL Elbow To RPV Safe End
21201-010-7	27.5"	CL Elbow To RPV Safe End
21201-011-8	27.5"	CL Elbow To RPV Safe End
21201-012-9	27.5"	CL Elbow To RPV Safe End

2. The second step is to select all of terminal ends in each pipe or branch run connected to component other than vessels. IWA-9000 defines terminal ends as, the extremities of piping runs that, connect to structures, components, or pipe anchors, each of which acts as a rigid restraint or provides at least 2 degrees of restraint to piping thermal expansion. At Vogtle, these piping terminal ends occur when a piping run connects to another piping run or a piping run connects to a large

**VOGTLE UNIT 2 THIRD INTERVAL ISI PLAN
CLASS 1 AND 2 PIPING**

component such as the Reactor Coolant pumps. There are three Class 1 anchors (21204-077-H003, 21204-078-H002, and 21204-079-H014).

The basis for terminal ends being selected by this Code Case as an alternative to the Code requirements is that if a branch line moves or is improperly restrained from moving during thermal growth, etc. the highest stresses would potentially be at the end of the piping where it is rigidly bound. Therefore, (in theory) there is increased potential for flaws to initiate and grow at the terminal end weld. For Vogtle, terminal ends will not include the branch connection welds (Items B9.31 or B9.32), but will, in general, include the first weld on the branch line. This determination was based on the fact that the branch connection welds are larger in diameter and are generally a larger weld when compared to first butt or socket weld on the branch connection line. Capped lines or small branch lines such as temperature elements that have limited movement of the line were also not included. There were 64 welds selected as terminal ends.

3. The third step is to select all dissimilar metal welds not covered under Category B-F. However, there are no dissimilar metal welds at Vogtle 2 not covered by Category B-F.
4. The fourth step is to select additional piping welds, such that the total number of circumferential butt welds (or branch connection or socket welds) selected for examination equals 25% of the total number of nonexempt circumferential butt welds (or branch connection or socket welds) in the reactor coolant piping system. There are 933 non-exempt Category B-J circumferential butt welds (or branch connection or socket welds) welds. Therefore a total of 235 terminal end and non-terminal end welds will be examined to meet these requirements. More welds may be selected if desired.

This additional scope of piping welds consists of the 933 non-exempt Category B-J welds minus the 64 piping terminal ends (step 2) and minus the 8 vessel terminal ends (step 1) for a total of 861 additional piping welds. The number of the additional welds to be examined is the total number of welds to be examined (235) minus the 72 terminal end welds already selected for examination. This yields a scope of 163 additional welds to be examined. The 163 examinations are then required to be distributed among the Class 1 systems (1201, 1204, and 1208) based on the number of non-exempt welds in each system.

There are 289 welds in the 1201 system which is about 34% of the total of 860 welds in this scope. There are 479 welds in the 1204 system which is about 56% of the total of the 861 welds, and there are 93 welds in the 1208 system which is about 10% of the 861 welds. Prorating the 163 welds to be examined among the three systems based on these percentages requires that approximately 55 welds be examined for the 1201 system, approximately 90 welds need to be examined for the 1204 system, and approximately 18 welds need to be examined for the 1208 system.

Within each system, examinations shall then be distributed between line sizes prorated, to the degree practicable, on the number of nonexempt welds in each line size. This distribution is shown in the following table.

**VOGTLE UNIT 2 THIRD INTERVAL ISI PLAN
CLASS 1 AND 2 PIPING**

It should be noted that the distribution of the welds shown in the table below is a proportional distribution (to the degree practical), and will not be an exact percentage when calculated. Additionally, more welds may be selected when appropriate.

Size (in.)	1201 (55 Welds Selected)		1204 (90 Welds Selected)		1208 (18 Welds Selected)	
	No.	No. To Examine	No.	No. To Examine	No.	No. To Examine
1	0	0	0	0		
1.25	4	0	0	0		
1.5	1	0	184	35	70	14
2	47	9	44	8	151	2
2.5	8	2	0	0		
3	42	8	42	8	12	2
4	66	13	0	0		
6	45	9	112	21		
8	0	0	22	4		
10	0	0	74	14		
12	35	7	1	0		
14	2	0	0	0		
16	4	0	0	0		
27.5	10	2	0	0		
29	9	2	0	0		
31	16	3	0	0		
TOTAL	289	55	479	90	93	18

**VOGTLE UNIT 2 THIRD INTERVAL ISI PLAN
CLASS 1 AND 2 PIPING**

CLASS 2 PIPING EXAMINATION REQUIREMENTS

The examination requirements for the Class 2 components identified on the P&IDs are defined in IWC-2500 for each examination category. Categories in the 2001 Edition of Section XI with Addenda through 2003 for piping are:

- Category C-F-1 Pressure Retaining Welds in Stainless Steel or High Alloy Piping
- Category C-F-2 Pressure Retaining Welds in Carbon or Low Alloy Steel Piping

DEVIATIONS TO CLASS 2 ISI CODE REQUIREMENTS

IWC-2500 provides the examination requirements for Class 2 components. These Code requirements may be deviated from by:

- The use of NRC approved alternatives per 10 CFR 50.55a(a)(3).
- The use of NRC approved Relief Requests per 10 CFR 50.55a(g)(6) when an examination requirement by the Code is determined to be impractical.
- The use of Code Cases approved for use by the NRC through publication in Regulatory Guide 1.147.

Significant deviations from IWC-2500 Code requirements at VEGP include Code Cases, Relief Requests, Alternatives, and NRC Safety Evaluations as shown in Volume 1.

One specific deviation is that in lieu of performing surface examinations on examination Category C-F-1 and C-F-2, Code Case N-663 was used to eliminate the examinations except for those areas identified by SNC as susceptible to outside surface attack. No C-F-1 welds are considered susceptible to outside surface attack because the insulation complies with Regulatory Guide 1.36, and the plant specific chemical controls should prevent the outside contamination of the subject piping welds with chlorides, fluorides, etc. No C-F-2 welds are considered susceptible to outside surface attack because they are not austenitic stainless steel. Additionally, Code Case N-624 was used, in some cases, to modify the sequence of examinations, however, the percentage requirements of Table IWB-2412-1 were met.

Category C-F-1 Pressure Retaining Welds in Austenitic Stainless Steel

During a portion of the 2nd Interval, Category C-F-1 welds were examined per the requirements of Section XI. By a September 30, 2003 NRC Safety Evaluation, the NRC approved a Risk-Informed ISI Program as an alternative for examination of piping welds. Subsequent 2nd Interval piping weld examinations were then performed per this Risk-Informed Program. A Risk-Informed ISI Program has not been approved for the 3rd Interval; therefore, the requirements of Section XI will be satisfied. Table IWC-2500-1, Category C-F-1 of the 2001 Edition of Section XI with Addenda through 2003 defines the examination requirements for these piping welds.

**VOGTLE UNIT 2 THIRD INTERVAL ISI PLAN
CLASS 1 AND 2 PIPING**

Table IWC-2500-1, Category C-F-1 requires that welds selected for examination shall include 7.5%, but not less than 28 circumferential welds not exempted by IWC-1220. Long-seam welds are not required for examination by the Code. Per Footnote 2, some welds that are not exempted by IWC-1220 are not required to be examined, because they are less than 3/8" (0.375") thick, but they are required to be included in the total weld count to which the 7.5% sample will be applied. Per the Code Compliance Scheduling Summary for C-F-1 welds there are 1474 non-exempt welds in the population (including the thin-wall piping), requiring a minimum of 110 examinations. Four additional examinations were selected for a total of 114. These examinations were selected as follows.

1. The first step is that (per Footnote 2) the 114 exams shall be distributed among Class 2 systems, to the degree practicable. This was done as follows:

The 1204 system has 536 C-F-1 non-exempt welds versus a total of 1474 non-exempt welds or about 36% of the population; therefore about 41 welds require examination. The 1205 system has a total of 405 C-F-1 welds versus a total of 1474 total welds or about 27% of the population; therefore about 31 (32 selected) welds require examination. The 1206 system has a total of 204 C-F-1 welds versus a total of 1474 welds or about 14% of the population; therefore about 16 welds require examination. The 1208 system has a total of 329 C-F-1 welds versus a total of 1474 welds or about 22% of the population; therefore about 25 welds require examination.

2. The second step is that (per Footnote 2) the exams within each system shall be distributed among each line size. This distribution is shown in the following table.

It should be noted that the distribution of the welds shown in the table below is a proportional distribution (to the degree practical), and will not be an exact percentage when calculated. Additionally, more welds may be selected when appropriate.

Size (in.)	21204 (41 Welds Selected)		21205 (32 Welds Selected)		21206 (16 Welds Selected)		21208 (25 Welds Selected)	
	No.	No. To Examine	No.	No. To Examine	No.	No. To Examine	No.	No. To Examine
2"	0	0	0	0	0	0	22	2
3"	27	2	0	0	0	0	124	9
4"	81	6	0	0	0	0	47	4
6"	142	11	0	0	4 ⁽¹⁾	0	69	5
8"	134	11	224	18	113 ⁽¹⁾	0	67	5
10"	48	4	0	0	22 ⁽¹⁾	0	0	0
12"	32	2	79	6	65	16	0	0
14"	6	0	102	8	0	0	0	0
24"	66	5	0	0	0	0	0	0
	536	41	405	32	204	16	329	25

(1) This piping is schedule 40S and has a wall thickness less than 0.375. Therefore, the welds are not subject to examination. The 16 weld examinations are examined in the 12" piping.

**VOGTLE UNIT 2 THIRD INTERVAL ISI PLAN
CLASS 1 AND 2 PIPING**

3. The third step was that (per Footnote 2) the welds shown above were distributed among non-exempt terminal ends and structural discontinuities (with a wall thickness $\geq .375''$) prorated, to the degree practicable, on the number of non-exempt terminal ends and structural discontinuities within each system. Terminal ends are the extremities of piping runs that connect to structures, components, or pipe anchors, each of which acts as a rigid restraint or provides at least 2 degrees of restraint to piping thermal expansion. A structural discontinuity is generally considered to be any weld except for pipe-to-pipe welds. For anchors, the weld on each side of the anchor was conservatively designated as a terminal end.

For the 21204 system, 38 welds were identified as Terminal Ends or about 7% of the non-exempt population; therefore, a minimum of 3 of the 41 welds selected for examination should be terminal ends. All piping welds except pipe-to-pipe welds are considered as structural discontinuities (including terminal ends). Therefore, the remaining 38 examinations were selected from the non pipe-to-pipe weld population.

For the 21205 system, 25 welds were identified as Terminal Ends or about 6% of the non-exempt population; therefore, a minimum of 2 of the 32 welds selected for examination should be terminal ends. All piping welds except pipe-to-pipe welds are considered as structural discontinuities (including terminal ends). Therefore, the remaining 30 examinations were selected from the non pipe-to-pipe weld population.

For the 21206 system, 10 welds were identified as Terminal Ends; however, all were located in piping with a wall thickness $< .375''$. All piping welds except pipe-to-pipe welds are considered as structural discontinuities (including terminal ends). Therefore, the 16 examinations were selected from the non pipe-to-pipe weld population.

For the 21208 system, 28 welds were identified as Terminal Ends or about 9% of the non-exempt population; therefore, a minimum of 2 of the 25 welds selected for examination should be terminal ends. All piping welds except pipe-to-pipe welds are considered as structural discontinuities (including terminal ends). Therefore, the remaining 23 examinations were selected from the non pipe-to-pipe weld population.

Sensitivity Study – As stated above, terminal ends are the extremities of piping runs that connect to structures, components, or pipe anchors, each of which acts as a rigid restraint or provides at least 2 degrees of restraint to piping thermal expansion. These terminal ends were selected by reviewing the ISI isometrics. Because this was a subjective exercise and because there is a small possibility that a terminal end was overlooked, it was determined that some additional terminal ends should be added into the scope of each system. To determine the minimal amount the following study was performed:

The 21205 system evaluation above shows that about 6% of the welds are terminal ends which required that about 3 terminal ends be examined. If the terminal end population was actually twice that counted then about 5 to 6 terminal end welds would require examination. Six terminal ends (that were also structural discontinuities) were selected for examination.

**VOGTLE UNIT 2 THIRD INTERVAL ISI PLAN
CLASS 1 AND 2 PIPING**

Category C-F-2 Pressure Retaining Welds in Carbon or Low Alloy Steel Piping

During a portion of the 2nd Interval, Category C-F-2 welds were examined per the requirements of Section XI. By a September 30, 2003 NRC Safety Evaluation, the NRC approved a Risk-Informed ISI Program as an alternative for examination of piping welds. Subsequent 2nd Interval piping weld examinations were then performed per this Risk-Informed Program. A Risk-Informed ISI Program has not been approved for the 3rd Interval; therefore, the requirements of Section XI will be satisfied. Table IWC-2500-1, Category C-F-2 of the 2001 Edition of Section XI with Addenda through 2003 defines the examination requirements for these piping welds.

Table IWC-2500-1, Category C-F-2 requires that welds selected for examination shall include 7.5%, but not less than 28 circumferential welds not exempted by IWC-1220. Long-seam welds are not required for examination by the Code. Per Footnote 2, some welds that are not exempted by IWC-1220 are not required to be examined, because they are less than 3/8" (0.375") thick, but they are required to be included in the total weld count to which the 7.5% sample will be applied. Per the Code Compliance Scheduling Summary for C-F-2 welds there are 664 non-exempt welds in the population (including the thin-wall piping), requiring 51 examinations. These examinations were selected as follows.

1. The first step is that (per Footnote 2) the 51 exams shall be distributed among Class 2 systems, to the degree practicable. This was done as follows:

The 1301 system has 159 C-F-2 non-exempt welds versus a total of 664 total non-exempt welds or 24% of the population; therefore about 12 welds require examination. The 1302 system has a total of 394 C-F-2 welds versus a total of 664 total welds or about 59% of the population; therefore about 30 welds require examination. The 1305 system has a total of 111 C-F-2 welds versus a total of 664 total welds or about 17% of the population; therefore about 9 welds require examination.

2. The second step is that (per Footnote 2) the exams within each system shall be distributed among each line size. This distribution is shown in the following table.

It should be noted that the distribution of the welds shown in the table below is a proportional distribution (to the degree practical), and will not be an exact percentage when calculated. Additionally, more welds may be selected when appropriate.

**VOGTLE UNIT 2 THIRD INTERVAL ISI PLAN
CLASS 1 AND 2 PIPING**

Size (in.)	1301 (12 Welds Selected)		1302 (30 Welds Selected)		1305 (9 Welds Selected)	
	No.	No. To Examine	No.	No. To Examine	No.	No. To Examine
3"	0	0	50	4	0	0
4"	0	0	162	12	0	0
6"	20	2	182	14	28	2
8"	48	4	0	0	0	0
10"	8	0	0	0	0	0
16"	0	0	0	0	83	7
26"	46	3	0	0	0	0
28"	21	2	0	0	0	0
29.5"	12	1	0	0	0	0
32"	4	0	0	0	0	0
	159	12	394	30	111	9

3. The third step was that (per Footnote 2) the welds shown above were distributed among non-exempt terminal ends and structural discontinuities (with a wall thickness prorated, to the degree practicable, on the number of non-exempt terminal ends and structural discontinuities within each system.

For the 1301 system, 20 welds were identified as Terminal Ends or about 13% of the non-exempt population; therefore, a minimum of 2 of the 12 welds selected for examination should be terminal ends. All piping welds except pipe-to-pipe welds are considered as structural discontinuities (including terminal ends). Therefore, the remaining 10 examinations were selected from the non pipe-to-pipe weld population.

For the 1302 system, 23 welds were identified as Terminal Ends or about 6% of the non-exempt population; therefore, a minimum of 2 of the 30 welds selected for examination should be terminal ends. All piping welds except pipe-to-pipe welds are considered as structural discontinuities (including terminal ends). Therefore, the remaining 28 examinations were selected from the non pipe-to-pipe weld population.

For the 1305 system, 20 welds were identified as Terminal Ends or about 18% of the non-exempt population; therefore, a minimum of 2 of the 10 welds selected for examination should be terminal ends. All piping welds except pipe-to-pipe welds are considered as structural discontinuities (including terminal ends). Therefore, the remaining 8 examinations were selected from the non pipe-to-pipe weld population.

Vogtle Nuclear Plant
Code Compliance Scheduling Summary - 3rd Interval
ISI - Code Edition - 2001 Edition with 2003 Addenda

Cat.	Item No.	Code Case	Population	Percent Required	Actual Required	Round Up	Total Exams	Period 1			Period 2			Period 3		
								Count	Actual Period	Round Up	Count	Actual Period	Round Up	Count	Actual Period	Round Up
B-F	B5.10		8	100%	8	8	8	0	0%	0%	0	0.00%	0%	8	100.00%	100%
B-F	B5.70		8	100%	8	8	8	2	25.00%	25%	2	50.00%	50%	4	100.00%	100%
Total:			16		16	16	16	2	12.50%	13%	2	25%	25%	12	100%	100%

Southern Nuclear Operating Company
3rd Interval
VOGTLE-2 ISI PLAN, VERSION 3.0

Category, Item No., Class	Summary No./ComplID/System	Scope / Method / Procedure	Dwg/ISO No. Comp. Desc. Code Case		Period 1		Period 2		Period 3	
					2VR13	2VR14	2VR14A	2VR15	2VR16	2VR17
B-F	V2 21201-V6-001-W33	ISI/UT/	ISI-21201-V6-001	ISI	-	-	-	-	-	-
B5.10	21201-V6-001-W33	ISI/UT/	OUTLET NOZZLE N1 TO SAFE END WELD	AUG	-	-	-	-	-	-
1	1201			OWN	-	-	-	-	-	-
				PRE	-	-	-	-	-	-
B-F	V2 21201-V6-001-W34	ISI/UT/	ISI-21201-V6-001	ISI	-	-	-	-	-	-
B5.10	21201-V6-001-W34	ISI/UT/	INLET NOZZLE N2 TO SAFE END WELD	AUG	-	-	-	-	-	-
1	1201			OWN	-	-	-	-	-	-
				PRE	-	-	-	-	-	-
B-F	V2 21201-V6-001-W35	ISI/UT/	ISI-21201-V6-001	ISI	-	-	-	-	-	-
B5.10	21201-V6-001-W35	ISI/UT/	INLET NOZZLE N3 TO SAFE END WELD	AUG	-	-	-	-	-	-
1	1201			OWN	-	-	-	-	-	-
				PRE	-	-	-	-	-	-
B-F	V2 21201-V6-001-W36	ISI/UT/	ISI-21201-V6-001	ISI	-	-	-	-	-	-
B5.10	21201-V6-001-W36	ISI/UT/	OUTLET NOZZLE N4 TO SAFE END WELD	AUG	-	-	-	-	-	-
1	1201			OWN	-	-	-	-	-	-
				PRE	-	-	-	-	-	-
B-F	V2 21201-V6-001-W37	ISI/UT/	ISI-21201-V6-001	ISI	-	-	-	-	-	-
B5.10	21201-V6-001-W37	ISI/UT/	OUTLET NOZZLE N5 TO SAFE END WELD	AUG	-	-	-	-	-	-
1	1201			OWN	-	-	-	-	-	-
				PRE	-	-	-	-	-	-
B-F	V2 21201-V6-001-W38	ISI/UT/	ISI-21201-V6-001	ISI	-	-	-	-	-	-
B5.10	21201-V6-001-W38	ISI/UT/	INLET NOZZLE N6 TO SAFE END WELD	AUG	-	-	-	-	-	-
1	1201			OWN	-	-	-	-	-	-
				PRE	-	-	-	-	-	-
B-F	V2 21201-V6-001-W39	ISI/UT/	ISI-21201-V6-001	ISI	-	-	-	-	-	-
B5.10	21201-V6-001-W39	ISI/UT/	INLET NOZZLE N7 TO SAFE END WELD	AUG	-	-	-	-	-	-
1	1201			OWN	-	-	-	-	-	-
				PRE	-	-	-	-	-	-
B-F	V2 21201-V6-001-W40	ISI/UT/	ISI-21201-V6-001	ISI	-	-	-	-	-	-
B5.10	21201-V6-001-W40	ISI/UT/	OUTLET NOZZLE N8 TO SAFE END WELD	AUG	-	-	-	-	-	-
1	1201			OWN	-	-	-	-	-	-
				PRE	-	-	-	-	-	-
B-F	V2 21201-001-5	ISI/UT/	ISI-21201-001	ISI	-	-	-	-	-	-
B5.70	21201-001-5		31" ELBOW TO NOZZLE	AUG	-	-	-	-	-	-
1	1201			OWN	-	-	-	-	-	-
				PRE	-	-	-	-	-	-

Southern Nuclear Operating Company
3rd Interval
VOGTLE-2 ISI PLAN, VERSION 3.0

Category, Item No., Class	Summary No./ComplD/System	Scope / Method / Procedure	Dwg/ISO No. Comp. Desc. Code Case		Period 1		Period 2			Period 3	
					2VR13	2VR14	2VR14A	2VR15	2VR16	2VR17	2VR18
B-F	V2 21201-002-5	ISI/UT/NMP-ES-024-507	ISI-21201-002	ISI	-	s	-	-	-	-	-
B5.70	21201-002-5		31" ELBOW TO NOZZLE	AUG	-	-	-	-	-	-	-
1	1201			OWN	-	-	-	-	-	-	-
				PRE	-	-	-	-	-	-	-
B-F	V2 21201-003-5	ISI/UT/	ISI-21201-003	ISI	-	-	-	-	-	s	-
B5.70	21201-003-5		31" ELBOW TO NOZZLE	AUG	-	-	-	-	-	-	-
1	1201			OWN	-	-	-	-	-	-	-
				PRE	-	-	-	-	-	-	-
B-F	V2 21201-004-6	ISI/UT/	ISI-21201-004	ISI	-	-	-	-	-	s	-
B5.70	21201-004-6		31" ELBOW TO NOZZLE	AUG	-	-	-	-	-	-	-
1	1201			OWN	-	-	-	-	-	-	-
				PRE	-	-	-	-	-	-	-
B-F	V2 21201-005-1	ISI/UT/	ISI-21201-005	ISI	-	-	-	s	-	-	-
B5.70	21201-005-1		31" NOZZLE TO ELBOW	AUG	-	-	-	-	-	-	-
1	1201			OWN	-	-	-	-	-	-	-
				PRE	-	-	-	-	-	-	-
B-F	V2 21201-006-1	ISI/UT/NMP-ES-024-507	ISI-21201-006	ISI	-	s	-	-	-	-	-
B5.70	21201-006-1		31" NOZZLE TO ELBOW	AUG	-	-	-	-	-	-	-
1	1201			OWN	-	-	-	-	-	-	-
				PRE	-	-	-	-	-	-	-
B-F	V2 21201-007-1	ISI/UT/	ISI-21201-007	ISI	-	-	-	-	-	s	-
B5.70	21201-007-1		31" NOZZLE TO ELBOW	AUG	-	-	-	-	-	-	-
1	1201			OWN	-	-	-	-	-	-	-
				PRE	-	-	-	-	-	-	-
B-F	V2 21201-008-1	ISI/UT/	ISI-21201-008	ISI	-	-	-	-	-	s	-
B5.70	21201-008-1		31" NOZZLE TO ELBOW	AUG	-	-	-	-	-	-	-
1	1201			OWN	-	-	-	-	-	-	-
				PRE	-	-	-	-	-	-	-

**Vogle Nuclear Plant
Code Compliance Scheduling Summary - 3rd Interval
ISI - Code Edition - 2001 Edition with 2003 Addenda**

Cat.	Item No.	Code Case	Population	Percent Required	Actual Required	Round Up	Total Exams	Period 1			Period 2			Period 3		
								Count	Actual Period	Round Up	Count	Actual Period	Round Up	Count	Actual Period	Round Up
B-J	B9.11		414	25%	103.5	104	109	22	21.26%	22%	28	48.31%	49%	59	105.31%	105%
B-J	B9.21		175	25%	43.75	44	50	0	0%	0%	23	52.57%	53%	27	114.29%	114%
B-J	B9.22		216	25%	54	54	53	17	31.48%	32%	14	57.41%	58%	22	98.15%	99%
B-J	B9.31		11	25%	2.75	3	3	0	0%	0%	2	72.73%	67%	1	109.09%	100%
B-J	B9.32		42	25%	10.5	11	6	0	0%	0%	0	0.00%	0%	6	57.14%	55%
B-J	B9.40		75	25%	18.75	19	15	0	0%	0%	4	21.33%	22%	11	80.00%	79%
Total:			933		235	235	236	39	16.50%	17%	71	46.80%	47%	126	100.00%	100%

Southern Nuclear Operating Company
3rd Interval
VOGTLE-2 ISI PLAN, VERSION 3.0

Category, Item No., Class	Summary No./CompID/System	Scope / Method / Procedure	Dwg/ISO No. Comp. Desc. Code Case		Period 1		Period 2		Period 3					
					2VR13	2VR14	2VR14A	2VR15	2VR16	2VR17	2VR18			
B-J B9.11 1	V2 21201-001-1 21201-001-1 1201	ISI/UT/	ISI-21201-001 29" SAFE END TO PIPE	ISI AUG OWN PRE	-	-	-	-	-	-	s	-	-	-
B-J B9.11 1	V2 21201-001-3 21201-001-3 1201	ISI/UT/	ISI-21201-001 29" PIPE TO ELBOW	ISI AUG OWN PRE	-	-	-	-	-	-	s	-	-	-
B-J B9.11 1	V2 21201-002-1 21201-002-1 1201	ISI/UT/	ISI-21201-002 29" SAFE END TO PIPE	ISI AUG OWN PRE	-	-	-	-	-	-	-	s	-	-
B-J B9.11 1	V2 21201-002-3 21201-002-3 1201		ISI-21201-002 29" PIPE TO ELBOW	ISI AUG OWN PRE	-	-	-	-	-	-	-	-	-	-
B-J B9.11 1	V2 21201-003-1 21201-003-1 1201	ISI/UT/	ISI-21201-003 29" SAFE END TO PIPE	ISI AUG OWN PRE	-	-	-	-	-	-	s	-	-	-
B-J B9.11 1	V2 21201-003-3 21201-003-3 1201	ISI/UT/	ISI-21201-003 29" PIPE TO ELBOW	ISI AUG OWN PRE	-	-	-	-	-	-	s	-	-	-
B-J B9.11 1	V2 21201-004-1 21201-004-1 1201	ISI/UT/	ISI-21201-004 29" SAFE END TO PIPE	ISI AUG OWN PRE	-	-	-	-	-	-	-	s	-	-
B-J B9.11 1	V2 21201-004-4 21201-004-4 1201		ISI-21201-004 29" PIPE TO ELBOW	ISI AUG OWN PRE	-	-	-	-	-	-	-	-	-	-
B-J B9.11 1	V2 21201-005-2 21201-005-2 1201		ISI-21201-005 31" ELBOW TO PIPE	ISI AUG OWN PRE	-	-	-	-	-	-	-	-	-	-
B-J B9.11 1	V2 21201-005-3 21201-005-3 1201		ISI-21201-005 31" PIPE TO ELBOW	ISI AUG OWN PRE	-	-	-	-	-	-	-	-	-	-

**Southern Nuclear Operating Company
3rd Interval
VOGTLE-2 ISI PLAN, VERSION 3.0**

Category, Item No., Class	Summary No./ComplID/System	Scope / Method / Procedure	Dwg/ISO No. Comp. Desc. Code Case		Period 1		Period 2			Period 3	
					2VR13	2VR14	2VR14A	2VR15	2VR16	2VR17	2VR18
B-J B9.11 1	V2 21201-005-4 21201-005-4 1201		ISI-21201-005 31" ELBOW TO PIPE	ISI AUG OWN PRE	-	-	-	-	-	-	-
B-J B9.11 1	V2 21201-005-7 21201-005-7 1201		ISI-21201-005 31" PIPE TO ELBOW	ISI AUG OWN PRE	-	-	-	-	-	-	-
B-J B9.11 1	V2 21201-005-8 21201-005-8 1201	ISI/UT/	ISI-21201-005 31" ELBOW TO NOZZLE	ISI AUG OWN PRE	-	-	-	-	-	s	-
B-J B9.11 1	V2 21201-006-2 21201-006-2 1201	ISI/UT/	ISI-21201-006 31" ELBOW TO PIPE	ISI AUG OWN PRE	-	-	-	-	-	s	-
B-J B9.11 1	V2 21201-006-3 21201-006-3 1201		ISI-21201-006 31" PIPE TO ELBOW	ISI AUG OWN PRE	-	-	-	-	-	-	-
B-J B9.11 1	V2 21201-006-4 21201-006-4 1201		ISI-21201-006 31" ELBOW TO PIPE	ISI AUG OWN PRE	-	-	-	-	-	-	-
B-J B9.11 1	V2 21201-006-7 21201-006-7 1201		ISI-21201-006 31" PIPE TO ELBOW	ISI AUG OWN PRE	-	-	-	-	-	-	-
B-J B9.11 1	V2 21201-006-8 21201-006-8 1201	ISI/UT/	ISI-21201-006 31" ELBOW TO NOZZLE	ISI AUG OWN PRE	-	-	-	-	-	s	-
B-J B9.11 1	V2 21201-007-2 21201-007-2 1201		ISI-21201-007 31" ELBOW TO PIPE	ISI AUG OWN PRE	-	-	-	-	-	-	-
B-J B9.11 1	V2 21201-007-3 21201-007-3 1201		ISI-21201-007 31" PIPE TO ELBOW	ISI AUG OWN PRE	-	-	-	-	-	-	-

**Southern Nuclear Operating Company
3rd Interval
VOGTLE-2 ISI PLAN, VERSION 3.0**

Category, Item No., Class	Summary No./CompID/System	Scope / Method / Procedure	Dwg/ISO No. Comp. Desc. Code Case		Period 1		Period 2		Period 3	
					2VR13	2VR14	2VR14A	2VR15	2VR16	2VR17
B-J B9.11 1	V2 21201-007-4 21201-007-4 1201		ISI-21201-007 31" ELBOW TO PIPE	ISI AUG OWN PRE	- - - -	- - - -	- - - -	- - - -	- - - -	- - - -
B-J B9.11 1	V2 21201-007-7 21201-007-7 1201		ISI-21201-007 31" PIPE TO ELBOW	ISI AUG OWN PRE	- - - -	- - - -	- - - -	- - - -	- - - -	- - - -
B-J B9.11 1	V2 21201-007-8 21201-007-8 1201	ISI/UT/	ISI-21201-007 31" ELBOW TO NOZZLE	ISI AUG OWN PRE	- - - -	- - - -	- - - -	- - - -	- - - -	s - - -
B-J B9.11 1	V2 21201-008-2 21201-008-2 1201	ISI/UT/	ISI-21201-008 31" ELBOW TO PIPE	ISI AUG OWN PRE	- - - -	- - - -	- - - -	- - - -	- - - -	s - - -
B-J B9.11 1	V2 21201-008-3 21201-008-3 1201	ISI/UT/	ISI-21201-008 31" PIPE TO ELBOW	ISI AUG OWN PRE	- - - -	- - - -	- - - -	- - - -	- - - -	s - - -
B-J B9.11 1	V2 21201-008-4 21201-008-4 1201		ISI-21201-008 31" ELBOW TO PIPE	ISI AUG OWN PRE	- - - -	- - - -	- - - -	- - - -	- - - -	- - - -
B-J B9.11 1	V2 21201-008-7 21201-008-7 1201		ISI-21201-008 31" PIPE TO ELBOW	ISI AUG OWN PRE	- - - -	- - - -	- - - -	- - - -	- - - -	- - - -
B-J B9.11 1	V2 21201-008-8 21201-008-8 1201	ISI/UT/	ISI-21201-008 31" ELBOW TO NOZZLE	ISI AUG OWN PRE	- - - -	- - - -	s - - -	- - - -	- - - -	- - - -
B-J B9.11 1	V2 21201-009-1 21201-009-1 1201	ISI/UT/	ISI-21201-009 27.5" NOZZLE TO PIPE	ISI AUG OWN PRE	- - - -	- - - -	- - - -	s - - -	- - - -	- - - -
B-J B9.11 1	V2 21201-009-8 21201-009-8 1201	ISI/UT/	ISI-21201-009 27.5" PIPE TO ELBOW	ISI AUG OWN PRE	- - - -	- - - -	- - - -	- - - -	- - - -	s - - -

**Southern Nuclear Operating Company
3rd Interval
VOGTLE-2 ISI PLAN, VERSION 3.0**

Category, Item No., Class	Summary No./CompID/System	Scope / Method / Procedure	Dwg/ISO No. Comp. Desc. Code Case		Period 1		Period 2		Period 3							
					2VR13	2VR14	2VR14A	2VR15	2VR16	2VR17	2VR18					
B-J B9.11 1	V2 21201-009-9 21201-009-9 1201	ISI/UT/	ISI-21201-009 27.5" ELBOW TO SAFE END	ISI AUG OWN PRE	-	-	-	-	-	s	-	-	-	-	-	-
B-J B9.11 1	V2 21201-010-1 21201-010-1 1201	ISI/UT/	ISI-21201-010 27.5" NOZZLE TO PIPE	ISI AUG OWN PRE	-	-	-	-	-	-	s	-	-	-	-	-
B-J B9.11 1	V2 21201-010-6 21201-010-6 1201		ISI-21201-010 27.5" PIPE TO ELBOW	ISI AUG OWN PRE	-	-	-	-	-	-	-	-	-	-	-	-
B-J B9.11 1	V2 21201-010-7 21201-010-7 1201	ISI/UT/	ISI-21201-010 27.5" ELBOW TO SAFE END	ISI AUG OWN PRE	-	-	-	-	-	-	s	-	-	-	-	-
B-J B9.11 1	V2 21201-011-1 21201-011-1 1201	ISI/UT/	ISI-21201-011 27.5" NOZZLE TO PIPE	ISI AUG OWN PRE	-	-	-	-	-	-	s	-	-	-	-	-
B-J B9.11 1	V2 21201-011-7 21201-011-7 1201		ISI-21201-011 27.5" PIPE TO ELBOW	ISI AUG OWN PRE	-	-	-	-	-	-	-	-	-	-	-	-
B-J B9.11 1	V2 21201-011-8 21201-011-8 1201		ISI-21201-011 27.5" ELBOW TO SAFE END	ISI AUG OWN PRE	-	-	-	-	-	-	-	-	-	-	-	-
B-J B9.11 1	V2 21201-012-1 21201-012-1 1201		ISI-21201-012 27.5" NOZZLE TO PIPE	ISI AUG OWN PRE	-	-	-	-	-	-	-	-	-	-	-	-
B-J B9.11 1	V2 21201-012-8 21201-012-8 1201	ISI/UT/	ISI-21201-012 27.5" PIPE TO ELBOW	ISI AUG OWN PRE	-	-	-	-	-	-	s	-	-	-	-	-
B-J B9.11 1	V2 21201-012-9 21201-012-9 1201	ISI/UT/	ISI-21201-012 27.5" ELBOW TO SAFE END	ISI AUG OWN PRE	-	-	-	-	-	-	-	s	-	-	-	-

Southern Nuclear Operating Company
3rd Interval
VOGTLE-2 ISI PLAN, VERSION 3.0

Category, Item No., Class	Summary No./ComplD/System	Scope / Method / Procedure	Dwg/ISO No. Comp. Desc. Code Case		Period 1		Period 2		Period 3	
					2VR13	2VR14	2VR14A	2VR15	2VR16	2VR17
B-J	V2 21201-029-1		ISI-21201-029	ISI	-	-	-	-	-	-
B9.11	21201-029-1		4" BRANCH CONNECTION TO PIPE	AUG	-	-	-	-	-	-
1	1201			OWN	-	-	-	-	-	-
				PRE	-	-	-	-	-	-
B-J	V2 21201-029-10		ISI-21201-029	ISI	-	-	-	-	-	-
B9.11	21201-029-10		4" ELBOW TO PIPE	AUG	-	-	-	-	-	-
1	1201			OWN	-	-	-	-	-	-
				PRE	-	-	-	-	-	-
B-J	V2 21201-029-11		ISI-21201-029	ISI	-	-	-	-	-	-
B9.11	21201-029-11		4" PIPE TO ELBOW	AUG	-	-	-	-	-	-
1	1201			OWN	-	-	-	-	-	-
				PRE	-	-	-	-	-	-
B-J	V2 21201-029-12	ISI/UT/	ISI-21201-029	ISI	-	-	-	-	s	-
B9.11	21201-029-12		4" ELBOW TO PIPE	AUG	-	-	-	-	-	-
1	1201			OWN	-	-	-	-	-	-
				PRE	-	-	-	-	-	-
B-J	V2 21201-029-13	ISI/UT/	ISI-21201-029	ISI	-	-	-	-	s	-
B9.11	21201-029-13		4" PIPE TO ELBOW	AUG	-	-	-	-	-	-
1	1201			OWN	-	-	-	-	-	-
				PRE	-	-	-	-	-	-
B-J	V2 21201-029-14	ISI/UT/	ISI-21201-029	ISI	-	-	-	-	s	-
B9.11	21201-029-14		4" ELBOW TO PIPE	AUG	-	-	-	-	-	-
1	1201			OWN	-	-	-	-	-	-
				PRE	-	-	-	-	-	-
B-J	V2 21201-029-15		ISI-21201-029	ISI	-	-	-	-	-	-
B9.11	21201-029-15		4" PIPE TO PIPE	AUG	-	-	-	-	-	-
1	1201			OWN	-	-	-	-	-	-
				PRE	-	-	-	-	-	-
B-J	V2 21201-029-16		ISI-21201-029	ISI	-	-	-	-	-	-
B9.11	21201-029-16		4" PIPE TO ELBOW	AUG	-	-	-	-	-	-
1	1201			OWN	-	-	-	-	-	-
				PRE	-	-	-	-	-	-
B-J	V2 21201-029-17		ISI-21201-029	ISI	-	-	-	-	-	-
B9.11	21201-029-17		4" ELBOW TO PIPE	AUG	-	-	-	-	-	-
1	1201			OWN	-	-	-	-	-	-
				PRE	-	-	-	-	-	-
B-J	V2 21201-029-18	ISI/UT/	ISI-21201-029	ISI	-	-	s	-	-	-
B9.11	21201-029-18		4" PIPE TO ELBOW	AUG	-	-	-	-	-	-
1	1201			OWN	-	-	-	-	-	-
				PRE	-	-	-	-	-	-

Southern Nuclear Operating Company
3rd Interval
VOGTLE-2 ISI PLAN, VERSION 3.0

Category, Item No., Class	Summary No./CompID/System	Scops / Method / Procedure	Dwg/ISO No. Comp. Desc. Code Case		Period 1		Period 2		Period 3							
					2VR13	2VR14	2VR14A	2VR15	2VR16	2VR17	2VR18					
B-J B9.11 1	V2 21201-029-19 21201-029-19 1201		ISI-21201-029 4* ELBOW TO PIPE	ISI AUG OWN PRE	-	-	-	-	-	-	-	-	-	-	-	-
B-J B9.11 1	V2 21201-029-20 21201-029-20 1201		ISI-21201-029 4* PIPE TO ELBOW	ISI AUG OWN PRE	-	-	-	-	-	-	-	-	-	-	-	-
B-J B9.11 1	V2 21201-029-21 21201-029-21 1201		ISI-21201-029 4* ELBOW TO PIPE	ISI AUG OWN PRE	-	-	-	-	-	-	-	-	-	-	-	-
B-J B9.11 1	V2 21201-029-22 21201-029-22 1201		ISI-21201-029 4* PIPE TO ELBOW	ISI AUG OWN PRE	-	-	-	-	-	-	-	-	-	-	-	-
B-J B9.11 1	V2 21201-029-23 21201-029-23 1201		ISI-21201-029 4* ELBOW TO PIPE	ISI AUG OWN PRE	-	-	-	-	-	-	-	-	-	-	-	-
B-J B9.11 1	V2 21201-029-24 21201-029-24 1201	ISI/UT/	ISI-21201-029 4* PIPE TO ELBOW	ISI AUG OWN PRE	-	-	-	s	-	-	-	-	-	-	-	-
B-J B9.11 1	V2 21201-029-25 21201-029-25 1201		ISI-21201-029 4* ELBOW TO PIPE	ISI AUG OWN PRE	-	-	-	-	-	-	-	-	-	-	-	-
B-J B9.11 1	V2 21201-029-26 21201-029-26 1201		ISI-21201-029 4* PIPE TO ELBOW	ISI AUG OWN PRE	-	-	-	-	-	-	-	-	-	-	-	-
B-J B9.11 1	V2 21201-029-27 21201-029-27 1201		ISI-21201-029 4* ELBOW TO PIPE	ISI AUG OWN PRE	-	-	-	-	-	-	-	-	-	-	-	-
B-J B9.11 1	V2 21201-029-28 21201-029-28 1201		ISI-21201-029 4* PIPE TO ELBOW	ISI AUG OWN PRE	-	-	-	-	-	-	-	-	-	-	-	-

**Southern Nuclear Operating Company
3rd Interval
VOGTLE-2 ISI PLAN, VERSION 3.0**

Category, Item No., Class	Summary No./ComplD/System	Scope / Method / Procedure	Dwg/ISO No. Comp. Desc. Code Case		Period 1		Period 2		Period 3										
					2VR13	2VR14	2VR14A	2VR15	2VR16	2VR17	2VR18								
B-J B9.11 1	V2 21201-029-29 21201-029-29 1201		ISI-21201-029 4" ELBOW TO PIPE	ISI AUG OWN PRE	-	-	-	-	-	-	-	-	-	-	-	-	-	-	-
B-J B9.11 1	V2 21201-029-3 21201-029-3 1201		ISI-21201-029 4" PIPE TO ELBOW	ISI AUG OWN PRE	-	-	-	-	-	-	-	-	-	-	-	-	-	-	-
B-J B9.11 1	V2 21201-029-30 21201-029-30 1201		ISI-21201-029 4" PIPE TO VALVE	ISI AUG OWN PRE	-	-	-	-	-	-	-	-	-	-	-	-	-	-	-
B-J B9.11 1	V2 21201-029-31 21201-029-31 1201		ISI-21201-029 4" VALVE TO PIPE	ISI AUG OWN PRE	-	-	-	-	-	-	-	-	-	-	-	-	-	-	-
B-J B9.11 1	V2 21201-029-32 21201-029-32 1201		ISI-21201-029 4" PIPE TO ELBOW	ISI AUG OWN PRE	-	-	-	-	-	-	-	-	-	-	-	-	-	-	-
B-J B9.11 1	V2 21201-029-33 21201-029-33 1201		ISI-21201-029 4" ELBOW TO PIPE	ISI AUG OWN PRE	-	-	-	-	-	-	-	-	-	-	-	-	-	-	-
B-J B9.11 1	V2 21201-029-34 21201-029-34 1201	ISI/UT/NMP-ES-024-501	ISI-21201-029 4" PIPE TO REDUCER	ISI AUG OWN PRE	-	s	-	-	-	-	-	-	-	-	-	-	-	-	-
B-J B9.11 1	V2 21201-029-35 21201-029-35 1201		ISI-21201-029 6" REDUCER TO PIPE	ISI AUG OWN PRE	-	-	-	-	-	-	-	-	-	-	-	-	-	-	-
B-J B9.11 1	V2 21201-029-36 21201-029-36 1201		ISI-21201-029 6" PIPE TO TEE	ISI AUG OWN PRE	-	-	-	-	-	-	-	-	-	-	-	-	-	-	-
B-J B9.11 1	V2 21201-029-4 21201-029-4 1201		ISI-21201-029 4" ELBOW TO PIPE	ISI AUG OWN PRE	-	-	-	-	-	-	-	-	-	-	-	-	-	-	-

Southern Nuclear Operating Company
3rd Interval
VOGTLE-2 ISI PLAN, VERSION 3.0

Category, Item No., Class	Summary No./ComplID/System	Scope / Method / Procedure	Dwg/ISO No. Comp. Desc. Code Case		Period 1		Period 2			Period 3	
					2VR13	2VR14	2VR14A	2VR15	2VR16	2VR17	2VR18
B-J	V2 21201-029-5		ISI-21201-029	ISI	-	-	-	-	-	-	-
B9.11	21201-029-5		4" PIPE TO PIPE	AUG	-	-	-	-	-	-	-
1	1201			OWN	-	-	-	-	-	-	-
				PRE	-	-	-	-	-	-	-
B-J	V2 21201-029-6		ISI-21201-029	ISI	-	-	-	-	-	-	-
B9.11	21201-029-6		4" PIPE TO PIPE	AUG	-	-	-	-	-	-	-
1	1201			OWN	-	-	-	-	-	-	-
				PRE	-	-	-	-	-	-	-
B-J	V2 21201-029-7		ISI-21201-029	ISI	-	-	-	-	-	-	-
B9.11	21201-029-7		4" PIPE TO ELBOW	AUG	-	-	-	-	-	-	-
1	1201			OWN	-	-	-	-	-	-	-
				PRE	-	-	-	-	-	-	-
B-J	V2 21201-029-8		ISI-21201-029	ISI	-	-	-	-	-	-	-
B9.11	21201-029-8		4" ELBOW TO PIPE	AUG	-	-	-	-	-	-	-
1	1201			OWN	-	-	-	-	-	-	-
				PRE	-	-	-	-	-	-	-
B-J	V2 21201-029-9		ISI-21201-029	ISI	-	-	-	-	-	-	-
B9.11	21201-029-9		4" PIPE TO ELBOW	AUG	-	-	-	-	-	-	-
1	1201			OWN	-	-	-	-	-	-	-
				PRE	-	-	-	-	-	-	-
B-J	V2 21201-030-1	ISI/UT/	ISI-21201-030	ISI	-	-	-	s	-	-	-
B9.11	21201-030-1		4" BRANCH CONNECTION TO PIPE	AUG	-	-	-	-	-	-	-
1	1201			OWN	-	-	-	-	-	-	-
				PRE	-	-	-	-	-	-	-
B-J	V2 21201-030-10		ISI-21201-030	ISI	-	-	-	-	-	-	-
B9.11	21201-030-10		4" PIPE TO ELBOW	AUG	-	-	-	-	-	-	-
1	1201			OWN	-	-	-	-	-	-	-
				PRE	-	-	-	-	-	-	-
B-J	V2 21201-030-11		ISI-21201-030	ISI	-	-	-	-	-	-	-
B9.11	21201-030-11		4" ELBOW TO PIPE	AUG	-	-	-	-	-	-	-
1	1201			OWN	-	-	-	-	-	-	-
				PRE	-	-	-	-	-	-	-
B-J	V2 21201-030-12		ISI-21201-030	ISI	-	-	-	-	-	-	-
B9.11	21201-030-12		4" PIPE TO ELBOW	AUG	-	-	-	-	-	-	-
1	1201			OWN	-	-	-	-	-	-	-
				PRE	-	-	-	-	-	-	-
B-J	V2 21201-030-13		ISI-21201-030	ISI	-	-	-	-	-	-	-
B9.11	21201-030-13		4" ELBOW TO PIPE	AUG	-	-	-	-	-	-	-
1	1201			OWN	-	-	-	-	-	-	-
				PRE	-	-	-	-	-	-	-

**Southern Nuclear Operating Company
3rd Interval
VOGTLE-2 ISI PLAN, VERSION 3.0**

Category, Item No., Class	Summary No./CompID/System	Scope / Method / Procedure	Dwg/ISO No. Comp. Desc. Code Case		Period 1		Period 2		Period 3							
					2VR13	2VR14	2VR14A	2VR15	2VR16	2VR17	2VR18					
B-J B9.11 1	V2 21201-030-14 21201-030-14 1201		ISI-21201-030 4" PIPE TO ELBOW	ISI AUG OWN PRE	-	-	-	-	-	-	-	-	-	-	-	-
B-J B9.11 1	V2 21201-030-15 21201-030-15 1201		ISI-21201-030 4" ELBOW TO PIPE	ISI AUG OWN PRE	-	-	-	-	-	-	-	-	-	-	-	-
B-J B9.11 1	V2 21201-030-16 21201-030-16 1201		ISI-21201-030 4" PIPE TO ELBOW	ISI AUG OWN PRE	-	-	-	-	-	-	-	-	-	-	-	-
B-J B9.11 1	V2 21201-030-17 21201-030-17 1201		ISI-21201-030 4" ELBOW TO PIPE	ISI AUG OWN PRE	-	-	-	-	-	-	-	-	-	-	-	-
B-J B9.11 1	V2 21201-030-18 21201-030-18 1201		ISI-21201-030 4" PIPE TO VALVE	ISI AUG OWN PRE	-	-	-	-	-	-	-	-	-	-	-	-
B-J B9.11 1	V2 21201-030-19 21201-030-19 1201	ISI/UT/NMP-ES-024-501	ISI-21201-030 4" VALVE TO PIPE	ISI AUG OWN PRE	-	s	-	-	-	-	-	-	-	-	-	-
B-J B9.11 1	V2 21201-030-2 21201-030-2 1201		ISI-21201-030 4" PIPE TO ELBOW	ISI AUG OWN PRE	-	-	-	-	-	-	-	-	-	-	-	-
B-J B9.11 1	V2 21201-030-20 21201-030-20 1201		ISI-21201-030 4" PIPE TO ELBOW	ISI AUG OWN PRE	-	-	-	-	-	-	-	-	-	-	-	-
B-J B9.11 1	V2 21201-030-21 21201-030-21 1201	ISI/UT/NMP-ES-024-501	ISI-21201-030 4" ELBOW TO PIPE	ISI AUG OWN PRE	-	s	-	-	-	-	-	-	-	-	-	-
B-J B9.11 1	V2 21201-030-22 21201-030-22 1201	ISI/UT/NMP-ES-024-501	ISI-21201-030 4" PIPE TO ELBOW	ISI AUG OWN PRE	-	s	-	-	-	-	-	-	-	-	-	-

Southern Nuclear Operating Company
3rd Interval
VOGTLE-2 ISI PLAN, VERSION 3.0

Category, Item No., Class	Summary No./CompID/System	Scope / Method / Procedure	Dwg/ISO No. Comp. Desc. Code Case		Period 1		Period 2		Period 3	
					2VR13	2VR14	2VR14A	2VR15	2VR16	2VR17
B-J	V2 21201-030-23		ISI-21201-030	ISI	-	-	-	-	-	-
B9.11	21201-030-23		4" ELBOW TO PIPE	AUG	-	-	-	-	-	-
1	1201			OWN	-	-	-	-	-	-
				PRE	-	-	-	-	-	-
B-J	V2 21201-030-24		ISI-21201-030	ISI	-	-	-	-	-	-
B9.11	21201-030-24		4" PIPE TO ELBOW	AUG	-	-	-	-	-	-
1	1201			OWN	-	-	-	-	-	-
				PRE	-	-	-	-	-	-
B-J	V2 21201-030-25		ISI-21201-030	ISI	-	-	-	-	-	-
B9.11	21201-030-25		4" ELBOW TO PIPE	AUG	-	-	-	-	-	-
1	1201			OWN	-	-	-	-	-	-
				PRE	-	-	-	-	-	-
B-J	V2 21201-030-26		ISI-21201-030	ISI	-	-	-	-	-	-
B9.11	21201-030-26		4" PIPE TO ELBOW	AUG	-	-	-	-	-	-
1	1201			OWN	-	-	-	-	-	-
				PRE	-	-	-	-	-	-
B-J	V2 21201-030-27		ISI-21201-030	ISI	-	-	-	-	-	-
B9.11	21201-030-27		4" ELBOW TO PIPE	AUG	-	-	-	-	-	-
1	1201			OWN	-	-	-	-	-	-
				PRE	-	-	-	-	-	-
B-J	V2 21201-030-28		ISI-21201-030	ISI	-	-	-	-	-	-
B9.11	21201-030-28		4" PIPE TO ELBOW	AUG	-	-	-	-	-	-
1	1201			OWN	-	-	-	-	-	-
				PRE	-	-	-	-	-	-
B-J	V2 21201-030-29	ISI/UT/	ISI-21201-030	ISI	-	-	-	-	-	s
B9.11	21201-030-29		4" ELBOW TO PIPE	AUG	-	-	-	-	-	-
1	1201			OWN	-	-	-	-	-	-
				PRE	-	-	-	-	-	-
B-J	V2 21201-030-3		ISI-21201-030	ISI	-	-	-	-	-	-
B9.11	21201-030-3		4" ELBOW TO PIPE	AUG	-	-	-	-	-	-
1	1201			OWN	-	-	-	-	-	-
				PRE	-	-	-	-	-	-
B-J	V2 21201-030-30	ISI/UT/	ISI-21201-030	ISI	-	-	-	s	-	-
B9.11	21201-030-30		4" PIPE TO TEE	AUG	-	-	-	-	-	-
1	1201			OWN	-	-	-	-	-	-
				PRE	-	-	-	-	-	-
B-J	V2 21201-030-31	ISI/UT/NMP-ES-024-501	ISI-21201-030	ISI	-	s	-	-	-	-
B9.11	21201-030-31		6" TEE TO PIPE	AUG	-	-	-	-	-	-
1	1201			OWN	-	-	-	-	-	-
				PRE	-	-	-	-	-	-

Southern Nuclear Operating Company
3rd Interval
VOGTLE-2 ISI PLAN, VERSION 3.0

Category, Item No., Class	Summary No./CompID/System	Scope / Method / Procedure	Dwg/ISO No. Comp. Desc. Code Case		Period 1		Period 2		Period 3								
					2VR13	2VR14	2VR14A	2VR15	2VR16	2VR17	2VR18						
B-J B9.11 1	V2 21201-030-33 21201-030-33 1201	ISI/UT/	ISI-21201-030 6" PIPE TO ELBOW	ISI AUG OWN PRE	-	-	-	-	-	s	-	-	-	-	-	-	-
B-J B9.11 1	V2 21201-030-34 21201-030-34 1201		ISI-21201-030 6" ELBOW TO PIPE	ISI AUG OWN PRE	-	-	-	-	-	-	-	-	-	-	-	-	-
B-J B9.11 1	V2 21201-030-35 21201-030-35 1201		ISI-21201-030 6" PIPE TO ELBOW	ISI AUG OWN PRE	-	-	-	-	-	-	-	-	-	-	-	-	-
B-J B9.11 1	V2 21201-030-36 21201-030-36 1201		ISI-21201-030 6" ELBOW TO PIPE	ISI AUG OWN PRE	-	-	-	-	-	-	-	-	-	-	-	-	-
B-J B9.11 1	V2 21201-030-37 21201-030-37 1201	ISI/UT/NMP-ES-024-501	ISI-21201-030 6" PIPE TO ELBOW	ISI AUG OWN PRE	-	s	-	-	-	-	-	-	-	-	-	-	-
B-J B9.11 1	V2 21201-030-38 21201-030-38 1201	ISI/UT/NMP-ES-024-501	ISI-21201-030 6" ELBOW TO PIPE	ISI AUG OWN PRE	-	s	-	-	-	-	-	-	-	-	-	-	-
B-J B9.11 1	V2 21201-030-39 21201-030-39 1201	ISI/UT/NMP-ES-024-501	ISI-21201-030 6" PIPE TO ELBOW	ISI AUG OWN PRE	-	s	-	-	-	-	-	-	-	-	-	-	-
B-J B9.11 1	V2 21201-030-4 21201-030-4 1201		ISI-21201-030 4" PIPE TO ELBOW	ISI AUG OWN PRE	-	-	-	-	-	-	-	-	-	-	-	-	-
B-J B9.11 1	V2 21201-030-40 21201-030-40 1201	ISI/UT/NMP-ES-024-501	ISI-21201-030 6" ELBOW TO PIPE	ISI AUG OWN PRE	-	s	-	-	-	-	-	-	-	-	-	-	-
B-J B9.11 1	V2 21201-030-41 21201-030-41 1201	ISI/UT/	ISI-21201-030 6" PIPE TO ELBOW	ISI AUG OWN PRE	-	-	-	-	-	-	s	-	-	-	-	-	-

Southern Nuclear Operating Company
3rd Interval
VOGTLE-2 ISI PLAN, VERSION 3.0

Category, Item No., Class	Summary No./CompID/System	Scope / Method / Procedure	Dwg/ISO No. Comp. Desc. Code Case		Period 1		Period 2		Period 3	
					2VR13	2VR14	2VR14A	2VR15	2VR16	2VR17
B-J B9.11 1	V2 21201-030-42 21201-030-42 1201		ISI-21201-030 6" ELBOW TO PIPE	ISI AUG OWN PRE	- - - -	- - - -	- - - -	- - - -	- - - -	- - - -
B-J B9.11 1	V2 21201-030-43 21201-030-43 1201	ISI/UT/NMP-ES-024-501	ISI-21201-030 6" PIPE TO REDUCER	ISI AUG OWN PRE	- - - -	s - - -	- - - -	- - - -	- - - -	- - - -
B-J B9.11 1	V2 21201-030-44 21201-030-44 1201	ISI/UT/NMP-ES-024-501	ISI-21201-030 4" REDUCER TO PIPE	ISI AUG OWN PRE	- - - -	s - - -	- - - -	- - - -	- - - -	- - - -
B-J B9.11 1	V2 21201-030-45 21201-030-45 1201	ISI/UT/NMP-ES-024-501	ISI-21201-030 4" PIPE TO ELBOW	ISI AUG OWN PRE	- - - -	s - - -	- - - -	- - - -	- - - -	- - - -
B-J B9.11 1	V2 21201-030-46 21201-030-46 1201	ISI/UT/NMP-ES-024-501	ISI-21201-030 4" ELBOW TO PIPE	ISI AUG OWN PRE	- - - -	s - - -	- - - -	- - - -	- - - -	- - - -
B-J B9.11 1	V2 21201-030-46 A 21201-030-46 A 1201		ISI-21201-030 4" PIPE TO PIPE	ISI AUG OWN PRE	- - - -	- - - -	- - - -	- - - -	- - - -	- - - -
B-J B9.11 1	V2 21201-030-47 21201-030-47 1201		ISI-21201-030 4" PIPE TO ELBOW	ISI AUG OWN PRE	- - - -	- - - -	- - - -	- - - -	- - - -	- - - -
B-J B9.11 1	V2 21201-030-48 21201-030-48 1201		ISI-21201-030 4" ELBOW TO PIPE	ISI AUG OWN PRE	- - - -	- - - -	- - - -	- - - -	- - - -	- - - -
B-J B9.11 1	V2 21201-030-5 21201-030-5 1201		ISI-21201-030 4" ELBOW TO PIPE	ISI AUG OWN PRE	- - - -	- - - -	- - - -	- - - -	- - - -	- - - -
B-J B9.11 1	V2 21201-030-6 21201-030-6 1201		ISI-21201-030 4" PIPE TO ELBOW	ISI AUG OWN PRE	- - - -	- - - -	- - - -	- - - -	- - - -	- - - -

Southern Nuclear Operating Company
3rd Interval
VOGTLE-2 ISI PLAN, VERSION 3.0

Category, Item No., Class	Summary No./CompID/System	Scope / Method / Procedure	Dwg/ISO No. Comp. Desc. Code Case		Period 1		Period 2			Period 3	
					2VR13	2VR14	2VR14A	2VR15	2VR16	2VR17	2VR18
B-J B9.11 1	V2 21201-030-7 21201-030-7 1201		ISI-21201-030 4" ELBOW TO PIPE	ISI AUG OWN PRE	-	-	-	-	-	-	-
B-J B9.11 1	V2 21201-030-8 21201-030-8 1201		ISI-21201-030 4" PIPE TO ELBOW	ISI AUG OWN PRE	-	-	-	-	-	-	-
B-J B9.11 1	V2 21201-030-9 21201-030-9 1201		ISI-21201-030 4" ELBOW TO PIPE	ISI AUG OWN PRE	-	-	-	-	-	-	-
B-J B9.11 1	V2 21201-036-1 21201-036-1 1201		ISI-21201-036 12" BRANCH CONNECTION TO PIPE (AI 87-0131)	ISI AUG OWN PRE	-	-	-	-	-	-	-
B-J B9.11 1	V2 21201-036-10 21201-036-10 1201		ISI-21201-036 12" PIPE TO ELBOW	ISI AUG OWN PRE	-	-	-	-	-	-	-
B-J B9.11 1	V2 21201-036-11 21201-036-11 1201		ISI-21201-036 12" ELBOW TO PIPE	ISI AUG OWN PRE	-	-	-	-	-	-	-
B-J B9.11 1	V2 21201-036-12 21201-036-12 1201	ISI/UT/	ISI-21201-036 12" PIPE TO ELBOW	ISI AUG OWN PRE	-	-	-	-	-	s	-
B-J B9.11 1	V2 21201-036-13 21201-036-13 1201	ISI/UT/	ISI-21201-036 12" ELBOW TO PIPE	ISI AUG OWN PRE	-	-	-	-	-	s	-
B-J B9.11 1	V2 21201-036-14 21201-036-14 1201	ISI/UT/	ISI-21201-036 12" PIPE TO ELBOW	ISI AUG OWN PRE	-	-	-	-	-	s	-
B-J B9.11 1	V2 21201-036-15 21201-036-15 1201	ISI/UT/	ISI-21201-036 12" ELBOW TO PIPE	ISI AUG OWN	-	-	-	-	-	s	-

**Southern Nuclear Operating Company
3rd Interval
VOGTLE-2 ISI PLAN, VERSION 3.0**

Category, Item No., Class	Summary No./CompID/System	Scope / Method / Procedure	Dwg/ISO No. Comp. Desc. Code Case		Period 1		Period 2		Period 3	
					2VR13	2VR14	2VR14A	2VR15	2VR16	2VR17
				PRE	-	-	-	-	-	-
B-J	V2 21201-036-16		ISI-21201-036	ISI	-	-	-	-	-	-
B9.11	21201-036-16		12" PIPE TO ELBOW	AUG	-	-	-	-	-	-
1	1201			OWN	-	-	-	-	-	-
				PRE	-	-	-	-	-	-
B-J	V2 21201-036-17		ISI-21201-036	ISI	-	-	-	-	-	-
B9.11	21201-036-17		12" ELBOW TO PIPE	AUG	-	-	-	-	-	-
1	1201			OWN	-	-	-	-	-	-
				PRE	-	-	-	-	-	-
B-J	V2 21201-036-18		ISI-21201-036	ISI	-	-	-	-	-	-
B9.11	21201-036-18		12" PIPE TO ELBOW	AUG	-	-	-	-	-	-
1	1201			OWN	-	-	-	-	-	-
				PRE	-	-	-	-	-	-
B-J	V2 21201-036-19		ISI-21201-036	ISI	-	-	-	-	-	-
B9.11	21201-036-19		12" ELBOW TO PIPE	AUG	-	-	-	-	-	-
1	1201			OWN	-	-	-	-	-	-
				PRE	-	-	-	-	-	-
B-J	V2 21201-036-2		ISI-21201-036	ISI	-	-	-	-	-	-
B9.11	21201-036-2		12" PIPE TO ELBOW (AI 87-0131)	AUG	-	-	-	-	-	-
1	1201			OWN	-	-	-	-	-	-
				PRE	-	-	-	-	-	-
B-J	V2 21201-036-21		ISI-21201-036	ISI	-	-	-	-	-	-
B9.11	21201-036-21		12" PIPE TO VALVE	AUG	-	-	-	-	-	-
1	1201			OWN	-	-	-	-	-	-
				PRE	-	-	-	-	-	-
B-J	V2 21201-036-3	ISI/UT/	ISI-21201-036	ISI	-	-	-	-	-	-
B9.11	21201-036-3		12" ELBOW TO PIPE	AUG	-	-	-	-	-	-
1	1201			OWN	-	-	-	-	-	-
				PRE	-	-	-	-	-	-
B-J	V2 21201-036-4		ISI-21201-036	ISI	-	-	-	-	-	-
B9.11	21201-036-4		12" PIPE TO TEE	AUG	-	-	-	-	-	-
1	1201			OWN	-	-	-	-	-	-
				PRE	-	-	-	-	-	-
B-J	V2 21201-036-5		ISI-21201-036	ISI	-	-	-	-	-	-
B9.11	21201-036-5		12" TEE TO PIPE	AUG	-	-	-	-	-	-
1	1201			OWN	-	-	-	-	-	-
				PRE	-	-	-	-	-	-
B-J	V2 21201-036-5 A		ISI-21201-036	ISI	-	-	-	-	-	-
B9.11	21201-036-5 A		12" PIPE TO PIPE	AUG	-	-	-	-	-	-
1	1201			OWN	-	-	-	-	-	-

**Southern Nuclear Operating Company
3rd Interval
VOGTLE-2 ISI PLAN, VERSION 3.0**

Category, Item No., Class	Summary No./CompID/System	Scope / Method / Procedure	Dwg/ISO No. Comp. Desc. Code Case		Period 1		Period 2			Period 3	
					2VR13	2VR14	2VR14A	2VR15	2VR16	2VR17	2VR18
				PRE	-	-	-	-	-	-	-
B-J	V2 21201-036-6		ISI-21201-036	ISI	-	-	-	-	-	-	-
B9.11	21201-036-6		12" PIPE TO VALVE (AI 87-0131)	AUG	-	-	-	-	-	-	-
1	1201			OWN	-	-	-	-	-	-	-
				PRE	-	-	-	-	-	-	-
B-J	V2 21201-036-7		ISI-21201-036	ISI	-	-	-	-	-	-	-
B9.11	21201-036-7		12" VALVE TO PIPE (AI 87-0131)	AUG	-	-	-	-	-	-	-
1	1201			OWN	-	-	-	-	-	-	-
				PRE	-	-	-	-	-	-	-
B-J	V2 21201-036-8	ISI/UT/	ISI-21201-036	ISI	-	-	-	-	-	s	-
B9.11	21201-036-8		12" PIPE TO ELBOW	AUG	-	-	-	-	-	-	-
1	1201			OWN	-	-	-	-	-	-	-
				PRE	-	-	-	-	-	-	-
B-J	V2 21201-036-9	ISI/UT/	ISI-21201-036	ISI	-	-	-	-	-	s	-
B9.11	21201-036-9		12" ELBOW TO PIPE	AUG	-	-	-	-	-	-	-
1	1201			OWN	-	-	-	-	-	-	-
				PRE	-	-	-	-	-	-	-
B-J	V2 21201-049-1	ISI/UT/	ISI-21201-049	ISI	-	-	-	s	-	-	-
B9.11	21201-049-1		12" BRANCH CONNECTION TO PIPE (AI 87-0131)	AUG	-	-	-	-	-	-	-
1	1201			OWN	-	-	-	-	-	-	-
				PRE	-	-	-	-	-	-	-
B-J	V2 21201-049-10		ISI-21201-049	ISI	-	-	-	-	-	-	-
B9.11	21201-049-10		12" PIPE TO ELBOW	AUG	-	-	-	-	-	-	-
1	1201			OWN	-	-	-	-	-	-	-
				PRE	-	-	-	-	-	-	-
B-J	V2 21201-049-11		ISI-21201-049	ISI	-	-	-	-	-	-	-
B9.11	21201-049-11		12" ELBOW TO PIPE	AUG	-	-	-	-	-	-	-
1	1201			OWN	-	-	-	-	-	-	-
				PRE	-	-	-	-	-	-	-
B-J	V2 21201-049-12		ISI-21201-049	ISI	-	-	-	-	-	-	-
B9.11	21201-049-12		12" PIPE TO ELBOW	AUG	-	-	-	-	-	-	-
1	1201			OWN	-	-	-	-	-	-	-
				PRE	-	-	-	-	-	-	-
B-J	V2 21201-049-13		ISI-21201-049	ISI	-	-	-	-	-	-	-
B9.11	21201-049-13		12" ELBOW TO PIPE	AUG	-	-	-	-	-	-	-
1	1201			OWN	-	-	-	-	-	-	-
				PRE	-	-	-	-	-	-	-
B-J	V2 21201-049-14		ISI-21201-049	ISI	-	-	-	-	-	-	-
B9.11	21201-049-14		12" PIPE TO ELBOW	AUG	-	-	-	-	-	-	-

**Southern Nuclear Operating Company
3rd Interval
VOGTLE-2 ISI PLAN, VERSION 3.0**

Category, Item No., Class	Summary No./ComplID/System	Scope / Method / Procedure	Dwg/ISO No. Comp. Desc. Code Case		Period 1		Period 2		Period 3	
					2VR13	2VR14	2VR14A	2VR15	2VR16	2VR17
1	1201			OWN PRE	-	-	-	-	-	-
B-J B9.11 1	V2 21201-049-15 21201-049-15 1201		ISI-21201-049 12" ELBOW TO PIPE	ISI AUG OWN PRE	-	-	-	-	-	-
B-J B9.11 1	V2 21201-049-16 21201-049-16 1201		ISI-21201-049 12" PIPE TO ELBOW	ISI AUG OWN PRE	-	-	-	-	-	-
B-J B9.11 1	V2 21201-049-17 21201-049-17 1201		ISI-21201-049 12" ELBOW TO PIPE	ISI AUG OWN PRE	-	-	-	-	-	-
B-J B9.11 1	V2 21201-049-19 21201-049-19 1201		ISI-21201-049 12" PIPE TO VALVE	ISI AUG OWN PRE	-	-	-	-	-	-
B-J B9.11 1	V2 21201-049-2 21201-049-2 1201		ISI-21201-049 12" PIPE TO TEE	ISI AUG OWN PRE	-	-	-	-	-	-
B-J B9.11 1	V2 21201-049-3 21201-049-3 1201		ISI-21201-049 12" TEE TO PIPE (AI 87-0131)	ISI AUG OWN PRE	-	-	-	-	-	-
B-J B9.11 1	V2 21201-049-4 21201-049-4 1201		ISI-21201-049 12" PIPE TO ELBOW (AI 87-0131)	ISI AUG OWN PRE	-	-	-	-	-	-
B-J B9.11 1	V2 21201-049-5 21201-049-5 1201		ISI-21201-049 12" ELBOW TO PIPE (AI 87-0131)	ISI AUG OWN PRE	-	-	-	-	-	-
B-J B9.11 1	V2 21201-049-6 21201-049-6 1201		ISI-21201-049 12" PIPE TO VALVE (AI 87-0131)	ISI AUG OWN PRE	-	-	-	-	-	-
B-J B9.11	V2 21201-049-7 21201-049-7		ISI-21201-049 12" VALVE TO PIPE	ISI AUG	-	-	-	-	-	-

Southern Nuclear Operating Company
3rd Interval
VOGTLE-2 ISI PLAN, VERSION 3.0

Category, Item No., Class	Summary No./ComplID/System	Scope / Method / Procedure	Dwg/ISO No. Comp. Desc. Code Case		Period 1		Period 2		Period 3	
					2VR13	2VR14	2VR14A	2VR15	2VR16	2VR17
1	1201			OWN	-	-	-	-	-	-
				PRE	-	-	-	-	-	-
B-J	V2 21201-053-1	ISI/UT/NMP-ES-024-501	ISI-21201-053	ISI	-	s	-	-	-	-
B9.11	21201-053-1		16" BRANCH CONNECTION TO PIPE	AUG	-	-	-	-	-	-
1	1201			OWN	-	-	-	-	-	-
				PRE	-	-	-	-	-	-
B-J	V2 21201-053-2		ISI-21201-053	ISI	-	-	-	-	-	-
B9.11	21201-053-2		16" PIPE TO PIPE	AUG	-	-	-	-	-	-
1	1201			OWN	-	-	-	-	-	-
				PRE	-	-	-	-	-	-
B-J	V2 21201-053-3		ISI-21201-053	ISI	-	-	-	-	-	-
B9.11	21201-053-3		16" PIPE TO PIPE	AUG	-	-	-	-	-	-
1	1201			OWN	-	-	-	-	-	-
				PRE	-	-	-	-	-	-
B-J	V2 21201-053-3 A		ISI-21201-053	ISI	-	-	-	-	-	-
B9.11	21201-053-3 A		16" PIPE TO PIPE	AUG	-	-	-	-	-	-
1	1201			OWN	-	-	-	-	-	-
				PRE	-	-	-	-	-	-
B-J	V2 21201-053-4	ISI/UT/NMP-ES-024-501	ISI-21201-053	ISI	-	s	-	-	-	-
B9.11	21201-053-4		16" PIPE TO REDUCER	AUG	-	-	-	-	-	-
1	1201			OWN	-	-	-	-	-	-
				PRE	-	-	-	-	-	-
B-J	V2 21201-053-5	ISI/UT/NMP-ES-024-501	ISI-21201-053	ISI	-	s	-	-	-	-
B9.11	21201-053-5		14" REDUCER TO PIPE	AUG	-	-	-	-	-	-
1	1201			OWN	-	-	-	-	-	-
				PRE	-	-	-	-	-	-
B-J	V2 21201-053-6		ISI-21201-053	ISI	-	-	-	-	-	-
B9.11	21201-053-6		14" PIPE TO SAFE END	AUG	-	-	-	-	-	-
1	1201			OWN	-	-	-	-	-	-
				PRE	-	-	-	-	-	-
B-J	V2 21201-056-2		ISI-21201-056	ISI	-	-	-	-	-	-
B9.11	21201-056-2		6" ELBOW TO PIPE	AUG	-	-	-	-	-	-
1	1201			OWN	-	-	-	-	-	-
				PRE	-	-	-	-	-	-
B-J	V2 21201-056-3		ISI-21201-056	ISI	-	-	-	-	-	-
B9.11	21201-056-3		6" PIPE TO ELBOW	AUG	-	-	-	-	-	-
1	1201			OWN	-	-	-	-	-	-
				PRE	-	-	-	-	-	-
B-J	V2 21201-056-4		ISI-21201-056	ISI	-	-	-	-	-	-
B9.11	21201-056-4		6" ELBOW TO PIPE	AUG	-	-	-	-	-	-

Southern Nuclear Operating Company
3rd Interval
VOGTLE-2 ISI PLAN, VERSION 3.0

Category, Item No., Class	Summary No./ComplID/System	Scope / Method / Procedure	Dwg/ISO No. Comp. Desc. Code Case		Period 1		Period 2			Period 3	
					2VR13	2VR14	2VR14A	2VR15	2VR16	2VR17	2VR18
1	1201			OWN PRE	-	-	-	-	-	-	-
B-J B9.11 1	V2 21201-056-5 21201-056-5 1201	ISI/UT/	ISI-21201-056 6" PIPE TO ELBOW	ISI AUG OWN PRE	-	-	-	-	-	-	s
B-J B9.11 1	V2 21201-056-6 21201-056-6 1201		ISI-21201-056 6" ELBOW TO FLANGE	ISI AUG OWN PRE	-	-	-	-	-	-	-
B-J B9.11 1	V2 21201-057-2 21201-057-2 1201		ISI-21201-057 6" ELBOW TO PIPE	ISI AUG OWN PRE	-	-	-	-	-	-	-
B-J B9.11 1	V2 21201-057-3 21201-057-3 1201		ISI-21201-057 6" PIPE TO ELBOW	ISI AUG OWN PRE	-	-	-	-	-	-	-
B-J B9.11 1	V2 21201-057-4 21201-057-4 1201		ISI-21201-057 6" ELBOW TO PIPE	ISI AUG OWN PRE	-	-	-	-	-	-	-
B-J B9.11 1	V2 21201-057-5 21201-057-5 1201		ISI-21201-057 6" PIPE TO ELBOW	ISI AUG OWN PRE	-	-	-	-	-	-	-
B-J B9.11 1	V2 21201-057-6 21201-057-6 1201		ISI-21201-057 6" ELBOW TO PIPE	ISI AUG OWN PRE	-	-	-	-	-	-	-
B-J B9.11 1	V2 21201-057-7 21201-057-7 1201		ISI-21201-057 6" PIPE TO ELBOW	ISI AUG OWN PRE	-	-	-	-	-	-	-
B-J B9.11 1	V2 21201-057-8 21201-057-8 1201		ISI-21201-057 6" ELBOW TO FLANGE	ISI AUG OWN PRE	-	-	-	-	-	-	-
B-J B9.11	V2 21201-058-2 21201-058-2		ISI-21201-058 6" ELBOW TO PIPE	ISI AUG	-	-	-	-	-	-	-

Southern Nuclear Operating Company
3rd Interval
VOGTLE-2 ISI PLAN, VERSION 3.0

Category, Item No., Class	Summary No./CompID/System	Scope / Method / Procedure	Dwg/ISO No. Comp. Desc. Code Case		Period 1		Period 2		Period 3	
					2VR13	2VR14	2VR14A	2VR15	2VR16	2VR17
1	1201			OWN	-	-	-	-	-	-
				PRE	-	-	-	-	-	-
B-J	V2 21201-058-3		ISI-21201-058	ISI	-	-	-	-	-	-
B9.11	21201-058-3		6" PIPE TO ELBOW	AUG	-	-	-	-	-	-
1	1201			OWN	-	-	-	-	-	-
				PRE	-	-	-	-	-	-
B-J	V2 21201-058-4		ISI-21201-058	ISI	-	-	-	-	-	-
B9.11	21201-058-4		6" ELBOW TO ELBOW	AUG	-	-	-	-	-	-
1	1201			OWN	-	-	-	-	-	-
				PRE	-	-	-	-	-	-
B-J	V2 21201-058-5		ISI-21201-058	ISI	-	-	-	-	-	-
B9.11	21201-058-5		6" ELBOW TO PIPE	AUG	-	-	-	-	-	-
1	1201			OWN	-	-	-	-	-	-
				PRE	-	-	-	-	-	-
B-J	V2 21201-058-6		ISI-21201-058	ISI	-	-	-	-	-	-
B9.11	21201-058-6		6" PIPE TO ELBOW	AUG	-	-	-	-	-	-
1	1201			OWN	-	-	-	-	-	-
				PRE	-	-	-	-	-	-
B-J	V2 21201-058-7		ISI-21201-058	ISI	-	-	-	-	-	-
B9.11	21201-058-7		6" ELBOW TO FLANGE	AUG	-	-	-	-	-	-
1	1201			OWN	-	-	-	-	-	-
				PRE	-	-	-	-	-	-
B-J	V2 21201-059-10		ISI-21201-059	ISI	-	-	-	-	-	-
B9.11	21201-059-10		6" ELBOW TO PIPE	AUG	-	-	-	-	-	-
1	1201			OWN	-	-	-	-	-	-
				PRE	-	-	-	-	-	-
B-J	V2 21201-059-11	ISI/UT/	ISI-21201-059	ISI	-	-	-	s	-	-
B9.11	21201-059-11		6" PIPE TO TEE	AUG	-	-	-	-	-	-
1	1201			OWN	-	-	-	-	-	-
				PRE	-	-	-	-	-	-
B-J	V2 21201-059-12		ISI-21201-059	ISI	-	-	-	-	-	-
B9.11	21201-059-12		6" TEE TO PIPE	AUG	-	-	-	-	-	-
1	1201			OWN	-	-	-	-	-	-
				PRE	-	-	-	-	-	-
B-J	V2 21201-059-13		ISI-21201-059	ISI	-	-	-	-	-	-
B9.11	21201-059-13		6" PIPE TO REDUCER	AUG	-	-	-	-	-	-
1	1201			OWN	-	-	-	-	-	-
				PRE	-	-	-	-	-	-
B-J	V2 21201-059-2		ISI-21201-059	ISI	-	-	-	-	-	-
B9.11	21201-059-2		6" ELBOW TO PIPE	AUG	-	-	-	-	-	-

Southern Nuclear Operating Company
3rd Interval
VOGTLE-2 ISI PLAN, VERSION 3.0

Category, Item No., Class	Summary No./ComplD/System	Scope / Method / Procedure	Dwg/ISO No. Comp. Desc. Code Case	Period 1		Period 2			Period 3	
				2VR13	2VR14	2VR14A	2VR15	2VR16	2VR17	2VR18
	1201			OWN	-	-	-	-	-	-
				PRE	-	-	-	-	-	-
B-J	V2 21201-059-3		ISI-21201-059	ISI	-	-	-	-	-	-
B9.11	21201-059-3		6" PIPE TO ELBOW	AUG	-	-	-	-	-	-
1	1201			OWN	-	-	-	-	-	-
				PRE	-	-	-	-	-	-
B-J	V2 21201-059-4		ISI-21201-059	ISI	-	-	-	-	-	-
B9.11	21201-059-4		6" ELBOW TO PIPE	AUG	-	-	-	-	-	-
1	1201			OWN	-	-	-	-	-	-
				PRE	-	-	-	-	-	-
B-J	V2 21201-059-5		ISI-21201-059	ISI	-	-	-	-	-	-
B9.11	21201-059-5		6" PIPE TO ELBOW	AUG	-	-	-	-	-	-
1	1201			OWN	-	-	-	-	-	-
				PRE	-	-	-	-	-	-
B-J	V2 21201-059-6		ISI-21201-059	ISI	-	-	-	-	-	-
B9.11	21201-059-6		6" ELBOW TO PIPE	AUG	-	-	-	-	-	-
1	1201			OWN	-	-	-	-	-	-
				PRE	-	-	-	-	-	-
B-J	V2 21201-059-7		ISI-21201-059	ISI	-	-	-	-	-	-
B9.11	21201-059-7		6" PIPE TO ELBOW	AUG	-	-	-	-	-	-
1	1201			OWN	-	-	-	-	-	-
				PRE	-	-	-	-	-	-
B-J	V2 21201-059-8		ISI-21201-059	ISI	-	-	-	-	-	-
B9.11	21201-059-8		6" ELBOW TO PIPE	AUG	-	-	-	-	-	-
1	1201			OWN	-	-	-	-	-	-
				PRE	-	-	-	-	-	-
B-J	V2 21201-059-9		ISI-21201-059	ISI	-	-	-	-	-	-
B9.11	21201-059-9		6" PIPE TO ELBOW	AUG	-	-	-	-	-	-
1	1201			OWN	-	-	-	-	-	-
				PRE	-	-	-	-	-	-
B-J	V2 21201-060-1		ISI-21201-060	ISI	-	-	-	-	-	-
B9.11	21201-060-1		6" TEE TO PIPE	AUG	-	-	-	-	-	-
1	1201			OWN	-	-	-	-	-	-
				PRE	-	-	-	-	-	-
B-J	V2 21201-060-2		ISI-21201-060	ISI	-	-	-	-	-	-
B9.11	21201-060-2		6" PIPE TO REDUCER	AUG	-	-	-	-	-	-
1	1201			OWN	-	-	-	-	-	-
				PRE	-	-	-	-	-	-
B-J	V2 21204-021-1	ISI/UT/	ISI-21204-021	ISI	-	-	-	s	-	-
B9.11	21204-021-1		8" VALVE TO PIPE (AI 87-0131)	AUG	-	-	-	-	-	-

Southern Nuclear Operating Company
3rd Interval
VOGTLE-2 ISI PLAN, VERSION 3.0

Category, Item No., Class	Summary No./ComplID/System	Scope / Method / Procedure	Dwg/ISO No. Comp. Desc. Code Case		Period 1		Period 2		Period 3	
					2VR13	2VR14	2VR14A	2VR15	2VR16	2VR17
1	1204			OWN PRE	-	-	-	-	-	-
B-J B9.11 1	V2 21204-021-10 21204-021-10 1204		ISI-21204-021 8" PIPE TO REDUCER	ISI AUG OWN PRE	-	-	-	-	-	-
B-J B9.11 1	V2 21204-021-11 21204-021-11 1204		ISI-21204-021 6" REDUCER TO PIPE	ISI AUG OWN PRE	-	-	-	-	-	-
B-J B9.11 1	V2 21204-021-12 21204-021-12 1204		ISI-21204-021 6" PIPE TO ELBOW	ISI AUG OWN PRE	-	-	-	-	-	-
B-J B9.11 1	V2 21204-021-13 21204-021-13 1204		ISI-21204-021 6" ELBOW TO PIPE	ISI AUG OWN PRE	-	-	-	-	-	-
B-J B9.11 1	V2 21204-021-14 21204-021-14 1204	ISI/UT/	ISI-21204-021 6" PIPE TO ELBOW	ISI AUG OWN PRE	-	-	-	-	s	-
B-J B9.11 1	V2 21204-021-15 21204-021-15 1204		ISI-21204-021 6" ELBOW TO PIPE	ISI AUG OWN PRE	-	-	-	-	-	-
B-J B9.11 1	V2 21204-021-16 21204-021-16 1204		ISI-21204-021 6" PIPE TO VALVE	ISI AUG OWN PRE	-	-	-	-	-	-
B-J B9.11 1	V2 21204-021-17 21204-021-17 1204		ISI-21204-021 6" VALVE TO PIPE (AI 87-0131)	ISI AUG OWN PRE	-	-	-	-	-	-
B-J B9.11 1	V2 21204-021-18 21204-021-18 1204	ISI/UT/	ISI-21204-021 6" PIPE TO ELBOW (AI 87-0131)	ISI AUG OWN PRE	-	-	s	-	-	-
B-J B9.11	V2 21204-021-19 21204-021-19	ISI/UT/	ISI-21204-021 6" ELBOW TO PIPE (AI 87-0131)	ISI AUG	-	-	s	-	-	-

**Southern Nuclear Operating Company
3rd Interval
VOGTLE-2 ISI PLAN, VERSION 3.0**

Category, Item No., Class	Summary No./CompID/System	Scope / Method / Procedure	Dwg/ISO No. Comp. Desc. Code Case		Period 1		Period 2			Period 3	
					2VR13	2VR14	2VR14A	2VR15	2VR16	2VR17	2VR18
	1204			OWN	-	-	-	-	-	-	-
	1204			PRE	-	-	-	-	-	-	-
B-J	V2 21204-021-20	ISI/UT/	ISI-21204-021	ISI	-	-	-	s	-	-	-
B9.11	21204-021-20		6" PIPE TO ELBOW	AUG	-	-	-	-	-	-	-
1	1204			OWN	-	-	-	-	-	-	-
	1204			PRE	-	-	-	-	-	-	-
B-J	V2 21204-021-21	ISI/UT/	ISI-21204-021	ISI	-	-	-	s	-	-	-
B9.11	21204-021-21		6" ELBOW TO PIPE	AUG	-	-	-	-	-	-	-
1	1204			OWN	-	-	-	-	-	-	-
	1204			PRE	-	-	-	-	-	-	-
B-J	V2 21204-021-22	ISI/UT/	ISI-21204-021	ISI	-	-	-	s	-	-	-
B9.11	21204-021-22		6" PIPE TO ELBOW	AUG	-	-	-	-	-	-	-
1	1204			OWN	-	-	-	-	-	-	-
	1204			PRE	-	-	-	-	-	-	-
B-J	V2 21204-021-23	ISI/UT/	ISI-21204-021	ISI	-	-	-	s	-	-	-
B9.11	21204-021-23		6" ELBOW TO PIPE	AUG	-	-	-	-	-	-	-
1	1204			OWN	-	-	-	-	-	-	-
	1204			PRE	-	-	-	-	-	-	-
B-J	V2 21204-021-24	ISI/UT/	ISI-21204-021	ISI	-	-	-	s	-	-	-
B9.11	21204-021-24		6" PIPE TO ELBOW	AUG	-	-	-	-	-	-	-
1	1204			OWN	-	-	-	-	-	-	-
	1204			PRE	-	-	-	-	-	-	-
B-J	V2 21204-021-25	ISI/UT/	ISI-21204-021	ISI	-	-	-	s	-	-	-
B9.11	21204-021-25		6" ELBOW TO PIPE	AUG	-	-	-	-	-	-	-
1	1204			OWN	-	-	-	-	-	-	-
	1204			PRE	-	-	-	-	-	-	-
B-J	V2 21204-021-26		ISI-21204-021	ISI	-	-	-	-	-	-	-
B9.11	21204-021-26		6" PIPE TO REDUCER (AI 87-0131)	AUG	-	-	-	-	-	-	-
1	1204			OWN	-	-	-	-	-	-	-
	1204			PRE	-	-	-	-	-	-	-
B-J	V2 21204-021-26 A	ISI/UT/NMP-ES-024-501	ISI-21204-021	ISI	-	s	-	-	-	-	-
B9.11	21204-021-26 A		12" REDUCER TO PIPE (AI 87-0131)	AUG	-	-	-	-	-	-	-
1	1204			OWN	-	-	-	-	-	-	-
	1204			PRE	-	-	-	-	-	-	-
B-J	V2 21204-021-27	ISI/UT/NMP-ES-024-501	ISI-21204-021	ISI	-	s	-	-	-	-	-
B9.11	21204-021-27		12" PIPE TO TEE	AUG	-	-	-	-	-	-	-
1	1204			OWN	-	-	-	-	-	-	-
	1204			PRE	-	-	-	-	-	-	-
B-J	V2 21204-021-3	ISI/UT/	ISI-21204-021	ISI	-	-	-	s	-	-	-
B9.11	21204-021-3		8" PIPE TO ELBOW	AUG	-	-	-	-	-	-	-

Southern Nuclear Operating Company
3rd Interval
VOGTLE-2 ISI PLAN, VERSION 3.0

Category, Item No., Class	Summary No./ComplID/System	Scope / Method / Procedure	Dwg/ISO No. Comp. Desc. Code Case		Period 1		Period 2			Period 3	
					2VR13	2VR14	2VR14A	2VR15	2VR16	2VR17	2VR18
	1204			OWN	-	-	-	-	-	-	-
				PRE	-	-	-	-	-	-	-
B-J	V2 21204-021-4	ISI/UT/	ISI-21204-021	ISI	-	-	-	-	s	-	-
B9.11	21204-021-4		8" ELBOW TO PIPE	AUG	-	-	-	-	-	-	-
1	1204			OWN	-	-	-	-	-	-	-
				PRE	-	-	-	-	-	-	-
B-J	V2 21204-021-5	ISI/UT/	ISI-21204-021	ISI	-	-	-	-	s	-	-
B9.11	21204-021-5		8" PIPE TO ELBOW	AUG	-	-	-	-	-	-	-
1	1204			OWN	-	-	-	-	-	-	-
				PRE	-	-	-	-	-	-	-
B-J	V2 21204-021-6		ISI-21204-021	ISI	-	-	-	-	-	-	-
B9.11	21204-021-6		8" ELBOW TO PIPE	AUG	-	-	-	-	-	-	-
1	1204			OWN	-	-	-	-	-	-	-
				PRE	-	-	-	-	-	-	-
B-J	V2 21204-021-7		ISI-21204-021	ISI	-	-	-	-	-	-	-
B9.11	21204-021-7		8" PIPE TO ELBOW	AUG	-	-	-	-	-	-	-
1	1204			OWN	-	-	-	-	-	-	-
				PRE	-	-	-	-	-	-	-
B-J	V2 21204-021-8		ISI-21204-021	ISI	-	-	-	-	-	-	-
B9.11	21204-021-8		8" ELBOW TO PIPE	AUG	-	-	-	-	-	-	-
1	1204			OWN	-	-	-	-	-	-	-
				PRE	-	-	-	-	-	-	-
B-J	V2 21204-021-9		ISI-21204-021	ISI	-	-	-	-	-	-	-
B9.11	21204-021-9		8" PIPE TO PIPE	AUG	-	-	-	-	-	-	-
1	1204			OWN	-	-	-	-	-	-	-
				PRE	-	-	-	-	-	-	-
B-J	V2 21204-023-1		ISI-21204-023	ISI	-	-	-	-	-	-	-
B9.11	21204-023-1		8" VALVE TO PIPE	AUG	-	-	-	-	-	-	-
1	1204			OWN	-	-	-	-	-	-	-
				PRE	-	-	-	-	-	-	-
B-J	V2 21204-023-10		ISI-21204-023	ISI	-	-	-	-	-	-	-
B9.11	21204-023-10		8" ELBOW TO PIPE (AI 87-0131)	AUG	-	-	-	-	-	-	-
1	1204			OWN	-	-	-	-	-	-	-
				PRE	-	-	-	-	-	-	-
B-J	V2 21204-023-11		ISI-21204-023	ISI	-	-	-	-	-	-	-
B9.11	21204-023-11		8" PIPE TO REDUCER (AI 87-0131)	AUG	-	-	-	-	-	-	-
1	1204			OWN	-	-	-	-	-	-	-
				PRE	-	-	-	-	-	-	-
B-J	V2 21204-023-12		ISI-21204-023	ISI	-	-	-	-	-	-	-
B9.11	21204-023-12		6" REDUCER TO PIPE (AI 87-0131)	AUG	-	-	-	-	-	-	-

Southern Nuclear Operating Company
3rd Interval
VOGTLE-2 ISI PLAN, VERSION 3.0

Category, Item No., Class	Summary No./ComplD/System	Scope / Method / Procedure	Dwg/ISO No. Comp. Desc. Code Case		Period 1		Period 2			Period 3	
					2VR13	2VR14	2VR14A	2VR15	2VR16	2VR17	2VR18
1	1204			OWN PRE	-	-	-	-	-	-	-
B-J B9.11 1	V2 21204-023-13 21204-023-13 1204		ISI-21204-023 6" PIPE TO ELBOW	ISI AUG OWN PRE	-	-	-	-	-	-	-
B-J B9.11 1	V2 21204-023-14 21204-023-14 1204		ISI-21204-023 6" ELBOW TO PIPE	ISI AUG OWN PRE	-	-	-	-	-	-	-
B-J B9.11 1	V2 21204-023-15R 21204-023-15R 1204	ISI/UT/	ISI-21204-023 6" PIPE TO VALVE	ISI AUG OWN PRE	-	-	-	-	-	s	-
B-J B9.11 1	V2 21204-023-16R 21204-023-16R 1204		ISI-21204-023 6" VALVE TO PIPE (AI 87-0131)	ISI AUG OWN PRE	-	-	-	-	-	-	-
B-J B9.11 1	V2 21204-023-17 21204-023-17 1204		ISI-21204-023 6" PIPE TO ELBOW	ISI AUG OWN PRE	-	-	-	-	-	-	-
B-J B9.11 1	V2 21204-023-18 21204-023-18 1204	ISI/UT/NMP-ES-024-501	ISI-21204-023 6" ELBOW TO PIPE	ISI AUG OWN PRE	-	s	-	-	-	-	-
B-J B9.11 1	V2 21204-023-19 21204-023-19 1204	ISI/UT/NMP-ES-024-501	ISI-21204-023 6" PIPE TO ELBOW	ISI AUG OWN PRE	-	s	-	-	-	-	-
B-J B9.11 1	V2 21204-023-2 A 21204-023-2 A 1204		ISI-21204-023 8" PIPE TO PIPE	ISI AUG OWN PRE	-	-	-	-	-	-	-
B-J B9.11 1	V2 21204-023-20 21204-023-20 1204	ISI/UT/NMP-ES-024-501	ISI-21204-023 6" ELBOW TO PIPE	ISI AUG OWN PRE	-	s	-	-	-	-	-
B-J B9.11	V2 21204-023-21 21204-023-21	ISI/UT/NMP-ES-024-501	ISI-21204-023 6" PIPE TO TEE (AI 87-0131)	ISI AUG	c	-	-	-	-	-	-

Southern Nuclear Operating Company
3rd Interval
VOGTLE-2 ISI PLAN, VERSION 3.0

Category, Item No., Class	Summary No./CompID/System	Scope / Method / Procedure	Dwg/ISO No. Comp. Desc. Code Case		Period 1		Period 2		Period 3	
					2VR13	2VR14	2VR14A	2VR15	2VR16	2VR17
1	1204			OWN PRE	-	-	-	-	-	-
B-J B9.11 1	V2 21204-023-3 21204-023-3 1204		ISI-21204-023 8" PIPE TO ELBOW	ISI AUG OWN PRE	-	-	-	-	-	-
B-J B9.11 1	V2 21204-023-4 21204-023-4 1204		ISI-21204-023 8" ELBOW TO PIPE	ISI AUG OWN PRE	-	-	-	-	-	-
B-J B9.11 1	V2 21204-023-5 21204-023-5 1204		ISI-21204-023 8" PIPE TO ELBOW	ISI AUG OWN PRE	-	-	-	-	-	-
B-J B9.11 1	V2 21204-023-6 21204-023-6 1204		ISI-21204-023 8" ELBOW TO PIPE	ISI AUG OWN PRE	-	-	-	-	-	-
B-J B9.11 1	V2 21204-023-7 21204-023-7 1204		ISI-21204-023 8" PIPE TO ELBOW	ISI AUG OWN PRE	-	-	-	-	-	-
B-J B9.11 1	V2 21204-023-8 21204-023-8 1204		ISI-21204-023 8" ELBOW TO PIPE	ISI AUG OWN PRE	-	-	-	-	-	-
B-J B9.11 1	V2 21204-023-9 21204-023-9 1204		ISI-21204-023 8" PIPE TO ELBOW (AI 87-0131)	ISI AUG OWN PRE	-	-	-	-	-	-
B-J B9.11 1	V2 21204-024-12 21204-024-12 1204		ISI-21204-024 6" REDUCER TO PIPE	ISI AUG OWN PRE	-	-	-	-	-	-
B-J B9.11 1	V2 21204-024-13 21204-024-13 1204		ISI-21204-024 6" PIPE TO ELBOW	ISI AUG OWN PRE	-	-	-	-	-	-
B-J B9.11	V2 21204-024-14 21204-024-14		ISI-21204-024 6" ELBOW TO PIPE	ISI AUG	-	-	-	-	-	-

Southern Nuclear Operating Company
3rd Interval
VOGTLE-2 ISI PLAN, VERSION 3.0

Category, Item No., Class	Summary No./CompID/System	Scope / Method / Procedure	Dwg/ISO No. Comp. Desc. Code Case		Period 1		Period 2		Period 3	
					2VR13	2VR14	2VR14A	2VR15	2VR16	2VR17
1	1204			OWN PRE	-	-	-	-	-	-
B-J B9.11 1	V2 21204-024-15 21204-024-15 1204	ISI/UT/	ISI-21204-024 6" PIPE TO VALVE	ISI AUG OWN PRE	-	-	-	-	s	-
B-J B9.11 1	V2 21204-024-16 21204-024-16 1204	ISI/UT/	ISI-21204-024 6" VALVE TO PIPE	ISI AUG OWN PRE	-	-	-	-	s	-
B-J B9.11 1	V2 21204-024-17 21204-024-17 1204	ISI/UT/	ISI-21204-024 6" PIPE TO ELBOW	ISI AUG OWN PRE	-	-	-	-	s	-
B-J B9.11 1	V2 21204-024-18 21204-024-18 1204		ISI-21204-024 6" ELBOW TO PIPE	ISI AUG OWN PRE	-	-	-	-	-	-
B-J B9.11 1	V2 21204-024-19 21204-024-19 1204		ISI-21204-024 6" PIPE TO ELBOW	ISI AUG OWN PRE	-	-	-	-	-	-
B-J B9.11 1	V2 21204-024-20 21204-024-20 1204	ISI/UT/	ISI-21204-024 6" ELBOW TO PIPE	ISI AUG OWN PRE	-	-	-	-	s	-
B-J B9.11 1	V2 21204-024-21 21204-024-21 1204	ISI/UT/	ISI-21204-024 6" PIPE TO BRANCH CONNECTION	ISI AUG OWN PRE	-	-	-	-	s	-
B-J B9.11 1	V2 21204-025-15 21204-025-15 1204		ISI-21204-025 6" REDUCER TO PIPE	ISI AUG OWN PRE	-	-	-	-	-	-
B-J B9.11 1	V2 21204-025-16 21204-025-16 1204		ISI-21204-025 6" PIPE TO ELBOW	ISI AUG OWN PRE	-	-	-	-	-	-
B-J B9.11	V2 21204-025-17 21204-025-17		ISI-21204-025 6" ELBOW TO PIPE	ISI AUG	-	-	-	-	-	-

Southern Nuclear Operating Company
3rd Interval
VOGTLE-2 ISI PLAN, VERSION 3.0

Category, Item No., Class	Summary No./ComplID/System	Scope / Method / Procedure	Dwg/ISO No. Comp. Desc. Code Case		Period 1		Period 2			Period 3	
					2VR13	2VR14	2VR14A	2VR15	2VR16	2VR17	2VR18
1	1204			OWN	-	-	-	-	-	-	-
				PRE	-	-	-	-	-	-	-
B-J	V2 21204-025-18		ISI-21204-025	ISI	-	-	-	-	-	-	-
B9.11	21204-025-18		6" PIPE TO ELBOW	AUG	-	-	-	-	-	-	-
1	1204			OWN	-	-	-	-	-	-	-
				PRE	-	-	-	-	-	-	-
B-J	V2 21204-025-19		ISI-21204-025	ISI	-	-	-	-	-	-	-
B9.11	21204-025-19		6" ELBOW TO PIPE	AUG	-	-	-	-	-	-	-
1	1204			OWN	-	-	-	-	-	-	-
				PRE	-	-	-	-	-	-	-
B-J	V2 21204-025-20		ISI-21204-025	ISI	-	-	-	-	-	-	-
B9.11	21204-025-20		6" PIPE TO PIPE	AUG	-	-	-	-	-	-	-
1	1204			OWN	-	-	-	-	-	-	-
				PRE	-	-	-	-	-	-	-
B-J	V2 21204-025-21		ISI-21204-025	ISI	-	-	-	-	-	-	-
B9.11	21204-025-21		6" PIPE TO VALVE	AUG	-	-	-	-	-	-	-
1	1204			OWN	-	-	-	-	-	-	-
				PRE	-	-	-	-	-	-	-
B-J	V2 21204-025-22		ISI-21204-025	ISI	-	-	-	-	-	-	-
B9.11	21204-025-22		6" VALVE TO PIPE	AUG	-	-	-	-	-	-	-
1	1204			OWN	-	-	-	-	-	-	-
				PRE	-	-	-	-	-	-	-
B-J	V2 21204-025-23		ISI-21204-025	ISI	-	-	-	-	-	-	-
B9.11	21204-025-23		6" PIPE TO ELBOW	AUG	-	-	-	-	-	-	-
1	1204			OWN	-	-	-	-	-	-	-
				PRE	-	-	-	-	-	-	-
B-J	V2 21204-025-24		ISI-21204-025	ISI	-	-	-	-	-	-	-
B9.11	21204-025-24		6" ELBOW TO PIPE	AUG	-	-	-	-	-	-	-
1	1204			OWN	-	-	-	-	-	-	-
				PRE	-	-	-	-	-	-	-
B-J	V2 21204-025-25		ISI-21204-025	ISI	-	-	-	-	-	-	-
B9.11	21204-025-25		6" PIPE TO ELBOW	AUG	-	-	-	-	-	-	-
1	1204			OWN	-	-	-	-	-	-	-
				PRE	-	-	-	-	-	-	-
B-J	V2 21204-025-26		ISI-21204-025	ISI	-	-	-	-	-	-	-
B9.11	21204-025-26		6" ELBOW TO PIPE	AUG	-	-	-	-	-	-	-
1	1204			OWN	-	-	-	-	-	-	-
				PRE	-	-	-	-	-	-	-
B-J	V2 21204-025-27	ISI/UT/	ISI-21204-025	ISI	-	-	-	-	-	s	-
B9.11	21204-025-27		6" PIPE TO BRANCH CONNECTION	AUG	-	-	-	-	-	-	-

Southern Nuclear Operating Company
3rd Interval
VOGTLE-2 ISI PLAN, VERSION 3.0

Category, Item No., Class	Summary No./CompID/System	Scope / Method / Procedure	Dwg/ISO No. Comp. Desc. Code Case	Period 1		Period 2			Period 3	
				2VR13	2VR14	2VR14A	2VR15	2VR16	2VR17	2VR18
1	1204			OWN	-	-	-	-	-	-
				PRE	-	-	-	-	-	-
B-J	V2 21204-042-1		ISI-21204-042	ISI	-	-	-	-	-	-
B9.11	21204-042-1		6" VALVE TO PIPE (AI 87-0131)	AUG	-	-	-	-	-	-
1	1204			OWN	-	-	-	-	-	-
				PRE	-	-	-	-	-	-
B-J	V2 21204-042-10		ISI-21204-042	ISI	-	-	-	-	-	-
B9.11	21204-042-10		6" PIPE TO PIPE	AUG	-	-	-	-	-	-
1	1204			OWN	-	-	-	-	-	-
				PRE	-	-	-	-	-	-
B-J	V2 21204-042-11		ISI-21204-042	ISI	-	-	-	-	-	-
B9.11	21204-042-11		6" PIPE TO ELBOW	AUG	-	-	-	-	-	-
1	1204			OWN	-	-	-	-	-	-
				PRE	-	-	-	-	-	-
B-J	V2 21204-042-12		ISI-21204-042	ISI	-	-	-	-	-	-
B9.11	21204-042-12		6" ELBOW TO PIPE	AUG	-	-	-	-	-	-
1	1204			OWN	-	-	-	-	-	-
				PRE	-	-	-	-	-	-
B-J	V2 21204-042-13		ISI-21204-042	ISI	-	-	-	-	-	-
B9.11	21204-042-13		6" PIPE TO ELBOW	AUG	-	-	-	-	-	-
1	1204			OWN	-	-	-	-	-	-
				PRE	-	-	-	-	-	-
B-J	V2 21204-042-14		ISI-21204-042	ISI	-	-	-	-	-	-
B9.11	21204-042-14		6" ELBOW TO PIPE (AI 87-0131)	AUG	-	-	-	-	-	-
1	1204			OWN	-	-	-	-	-	-
				PRE	-	-	-	-	-	-
B-J	V2 21204-042-15	ISI/UT/	ISI-21204-042	ISI	-	-	-	-	s	-
B9.11	21204-042-15		6" PIPE TO TEE (AI 87-0131)	AUG	-	-	-	-	-	-
1	1204			OWN	-	-	-	-	-	-
				PRE	-	-	-	-	-	-
B-J	V2 21204-042-3		ISI-21204-042	ISI	-	-	-	-	-	-
B9.11	21204-042-3		6" PIPE TO ELBOW	AUG	-	-	-	-	-	-
1	1204			OWN	-	-	-	-	-	-
				PRE	-	-	-	-	-	-
B-J	V2 21204-042-4		ISI-21204-042	ISI	-	-	-	-	-	-
B9.11	21204-042-4		6" ELBOW TO PIPE	AUG	-	-	-	-	-	-
1	1204			OWN	-	-	-	-	-	-
				PRE	-	-	-	-	-	-
B-J	V2 21204-042-5		ISI-21204-042	ISI	-	-	-	-	-	-
B9.11	21204-042-5		6" PIPE TO ELBOW	AUG	-	-	-	-	-	-

**Southern Nuclear Operating Company
3rd Interval
VOGTLE-2 ISI PLAN, VERSION 3.0**

Category, Item No., Class	Summary No./CompID/System	Scope / Method / Procedure	Dwg/ISO No. Comp. Desc. Code Case		Period 1		Period 2		Period 3	
					2VR13	2VR14	2VR14A	2VR15	2VR16	2VR17
1	1204			OWN PRE	-	-	-	-	-	-
B-J B9.11 1	V2 21204-042-6 21204-042-6 1204		ISI-21204-042 6" ELBOW TO PIPE	ISI AUG OWN PRE	-	-	-	-	-	-
B-J B9.11 1	V2 21204-042-7 21204-042-7 1204		ISI-21204-042 6" PIPE TO ELBOW	ISI AUG OWN PRE	-	-	-	-	-	-
B-J B9.11 1	V2 21204-042-8 21204-042-8 1204	ISI/UT/	ISI-21204-042 6" ELBOW TO PIPE	ISI AUG OWN PRE	-	-	-	-	s	-
B-J B9.11 1	V2 21204-042-8 A 21204-042-8 A 1204		ISI-21204-042 6" PIPE TO PIPE	ISI AUG OWN PRE	-	-	-	-	-	-
B-J B9.11 1	V2 21204-042-9 21204-042-9 1204		ISI-21204-042 6" PIPE TO PIPE	ISI AUG OWN PRE	-	-	-	-	-	-
B-J B9.11 1	V2 21204-043-1 21204-043-1 1204		ISI-21204-043 6" VALVE TO PIPE (AI 87-0131)	ISI AUG OWN PRE	-	-	-	-	-	-
B-J B9.11 1	V2 21204-043-10 21204-043-10 1204		ISI-21204-043 6" ELBOW TO PIPE (AI 87-0131)	ISI AUG OWN PRE	-	-	-	-	-	-
B-J B9.11 1	V2 21204-043-11 21204-043-11 1204	ISI/UT/	ISI-21204-043 6" PIPE TO ELBOW	ISI AUG OWN PRE	-	-	-	-	s	-
B-J B9.11 1	V2 21204-043-12 21204-043-12 1204		ISI-21204-043 6" ELBOW TO PIPE	ISI AUG OWN PRE	-	-	-	-	-	-
B-J B9.11	V2 21204-043-13 21204-043-13	ISI/UT/	ISI-21204-043 6" PIPE TO TEE	ISI AUG	-	-	-	-	-	s

Southern Nuclear Operating Company
3rd Interval
VOGTLE-2 ISI PLAN, VERSION 3.0

Category, Item No., Class	Summary No./CompID/System	Scope / Method / Procedure	Dwg/ISO No. Comp. Desc. Code Case		Period 1		Period 2		Period 3	
					2VR13	2VR14	2VR14A	2VR15	2VR16	2VR17
1	1204			OWN PRE	-	-	-	-	-	-
B-J B9.11 1	V2 21204-043-3 21204-043-3 1204	ISI/UT/	ISI-21204-043 6" PIPE TO ELBOW	ISI AUG OWN PRE	-	-	-	-	-	-
B-J B9.11 1	V2 21204-043-4 21204-043-4 1204		ISI-21204-043 6" ELBOW TO PIPE	ISI AUG OWN PRE	-	-	-	-	-	-
B-J B9.11 1	V2 21204-043-5 21204-043-5 1204	ISI/UT/	ISI-21204-043 6" PIPE TO ELBOW	ISI AUG OWN PRE	-	-	-	-	s	-
B-J B9.11 1	V2 21204-043-6 21204-043-6 1204		ISI-21204-043 6" ELBOW TO PIPE	ISI AUG OWN PRE	-	-	-	-	-	-
B-J B9.11 1	V2 21204-043-7 21204-043-7 1204		ISI-21204-043 6" PIPE TO ELBOW	ISI AUG OWN PRE	-	-	-	-	-	-
B-J B9.11 1	V2 21204-043-8 21204-043-8 1204		ISI-21204-043 6" ELBOW TO PIPE	ISI AUG OWN PRE	-	-	-	-	-	-
B-J B9.11 1	V2 21204-043-9 21204-043-9 1204		ISI-21204-043 6" PIPE TO ELBOW	ISI AUG OWN PRE	-	-	-	-	-	-
B-J B9.11 1	V2 21204-044-1 21204-044-1 1204		ISI-21204-044 6" VALVE TO PIPE (AI 87-0131)	ISI AUG OWN PRE	-	-	-	-	-	-
B-J B9.11 1	V2 21204-044-10 21204-044-10 1204		ISI-21204-044 6" ELBOW TO PIPE	ISI AUG OWN PRE	-	-	-	-	-	-
B-J B9.11	V2 21204-044-11 21204-044-11		ISI-21204-044 6" PIPE TO ELBOW	ISI AUG	-	-	-	-	-	-

Southern Nuclear Operating Company
3rd Interval
VOGTLE-2 ISI PLAN, VERSION 3.0

Category, Item No., Class	Summary No./ComplD/System	Scopes / Method / Procedure	Dwg/ISO No. Comp. Desc. Code Case		Period 1		Period 2		Period 3	
					2VR13	2VR14	2VR14A	2VR15	2VR16	2VR17
1	1204			OWN	-	-	-	-	-	-
				PRE	-	-	-	-	-	-
B-J	V2 21204-044-12		ISI-21204-044	ISI	-	-	-	-	-	-
B9.11	21204-044-12		6" ELBOW TO PIPE	AUG	-	-	-	-	-	-
1	1204			OWN	-	-	-	-	-	-
				PRE	-	-	-	-	-	-
B-J	V2 21204-044-13	ISI/UT/	ISI-21204-044	ISI	-	-	-	-	-	s
B9.11	21204-044-13		6" PIPE TO TEE (AI 87-0131)	AUG	-	-	-	-	-	-
1	1204			OWN	-	-	-	-	-	-
				PRE	-	-	-	-	-	-
B-J	V2 21204-044-3		ISI-21204-044	ISI	-	-	-	-	-	-
B9.11	21204-044-3		6" PIPE TO ELBOW	AUG	-	-	-	-	-	-
1	1204			OWN	-	-	-	-	-	-
				PRE	-	-	-	-	-	-
B-J	V2 21204-044-4		ISI-21204-044	ISI	-	-	-	-	-	-
B9.11	21204-044-4		6" ELBOW TO PIPE	AUG	-	-	-	-	-	-
1	1204			OWN	-	-	-	-	-	-
				PRE	-	-	-	-	-	-
B-J	V2 21204-044-5		ISI-21204-044	ISI	-	-	-	-	-	-
B9.11	21204-044-5		6" PIPE TO ELBOW	AUG	-	-	-	-	-	-
1	1204			OWN	-	-	-	-	-	-
				PRE	-	-	-	-	-	-
B-J	V2 21204-044-6		ISI-21204-044	ISI	-	-	-	-	-	-
B9.11	21204-044-6		6" ELBOW TO PIPE	AUG	-	-	-	-	-	-
1	1204			OWN	-	-	-	-	-	-
				PRE	-	-	-	-	-	-
B-J	V2 21204-044-7		ISI-21204-044	ISI	-	-	-	-	-	-
B9.11	21204-044-7		6" PIPE TO ELBOW	AUG	-	-	-	-	-	-
1	1204			OWN	-	-	-	-	-	-
				PRE	-	-	-	-	-	-
B-J	V2 21204-044-8		ISI-21204-044	ISI	-	-	-	-	-	-
B9.11	21204-044-8		6" ELBOW TO PIPE	AUG	-	-	-	-	-	-
1	1204			OWN	-	-	-	-	-	-
				PRE	-	-	-	-	-	-
B-J	V2 21204-044-9		ISI-21204-044	ISI	-	-	-	-	-	-
B9.11	21204-044-9		6" PIPE TO ELBOW	AUG	-	-	-	-	-	-
1	1204			OWN	-	-	-	-	-	-
				PRE	-	-	-	-	-	-
B-J	V2 21204-045-1		ISI-21204-045	ISI	-	-	-	-	-	-
B9.11	21204-045-1		6" VALVE TO PIPE (AI 87-0131)	AUG	-	-	-	-	-	-

Southern Nuclear Operating Company
3rd Interval
VOGTLE-2 ISI PLAN, VERSION 3.0

Category, Item No., Class	Summary No./CompID/System	Scope / Method / Procedure	Dwg/ISO No. Comp. Desc. Code Case	Period 1		Period 2			Period 3	
				2VR13	2VR14	2VR14A	2VR15	2VR16	2VR17	2VR18
	1204			OWN	-	-	-	-	-	-
	1204			PRE	-	-	-	-	-	-
B-J	V2 21204-045-10		ISI-21204-045	ISI	-	-	-	-	-	-
B9.11	21204-045-10		6" ELBOW TO PIPE	AUG	-	-	-	-	-	-
1	1204			OWN	-	-	-	-	-	-
	1204			PRE	-	-	-	-	-	-
B-J	V2 21204-045-11		ISI-21204-045	ISI	-	-	-	-	-	-
B9.11	21204-045-11		6" PIPE TO PIPE	AUG	-	-	-	-	-	-
1	1204			OWN	-	-	-	-	-	-
	1204			PRE	-	-	-	-	-	-
B-J	V2 21204-045-12		ISI-21204-045	ISI	-	-	-	-	-	-
B9.11	21204-045-12		6" PIPE TO ELBOW	AUG	-	-	-	-	-	-
1	1204			OWN	-	-	-	-	-	-
	1204			PRE	-	-	-	-	-	-
B-J	V2 21204-045-13		ISI-21204-045	ISI	-	-	-	-	-	-
B9.11	21204-045-13		6" ELBOW TO PIPE	AUG	-	-	-	-	-	-
1	1204			OWN	-	-	-	-	-	-
	1204			PRE	-	-	-	-	-	-
B-J	V2 21204-045-14		ISI-21204-045	ISI	-	-	-	-	-	-
B9.11	21204-045-14		6" PIPE TO ELBOW	AUG	-	-	-	-	-	-
1	1204			OWN	-	-	-	-	-	-
	1204			PRE	-	-	-	-	-	-
B-J	V2 21204-045-15		ISI-21204-045	ISI	-	-	-	-	-	-
B9.11	21204-045-15		6" ELBOW TO PIPE	AUG	-	-	-	-	-	-
1	1204			OWN	-	-	-	-	-	-
	1204			PRE	-	-	-	-	-	-
B-J	V2 21204-045-16		ISI-21204-045	ISI	-	-	-	-	-	-
B9.11	21204-045-16		6" PIPE TO ELBOW	AUG	-	-	-	-	-	-
1	1204			OWN	-	-	-	-	-	-
	1204			PRE	-	-	-	-	-	-
B-J	V2 21204-045-17		ISI-21204-045	ISI	-	-	-	-	-	-
B9.11	21204-045-17		6" ELBOW TO PIPE	AUG	-	-	-	-	-	-
1	1204			OWN	-	-	-	-	-	-
	1204			PRE	-	-	-	-	-	-
B-J	V2 21204-045-18		ISI-21204-045	ISI	-	-	-	-	-	-
B9.11	21204-045-18		6" PIPE TO ELBOW	AUG	-	-	-	-	-	-
1	1204			OWN	-	-	-	-	-	-
	1204			PRE	-	-	-	-	-	-
B-J	V2 21204-045-19		ISI-21204-045	ISI	-	-	-	-	-	-
B9.11	21204-045-19		6" ELBOW TO PIPE	AUG	-	-	-	-	-	-

Southern Nuclear Operating Company
3rd Interval
VOGTLE-2 ISI PLAN, VERSION 3.0

Category, Item No., Class	Summary No./CompID/System	Scope / Method / Procedure	Dwg/ISO No. Comp. Desc. Code Case		Period 1		Period 2			Period 3	
					2VR13	2VR14	2VR14A	2VR15	2VR16	2VR17	2VR18
1	1204			OWN	-	-	-	-	-	-	-
				PRE	-	-	-	-	-	-	-
B-J	V2 21204-045-20		ISI-21204-045	ISI	-	-	-	-	-	-	-
B9.11	21204-045-20		6" PIPE TO ELBOW	AUG	-	-	-	-	-	-	-
1	1204			OWN	-	-	-	-	-	-	-
				PRE	-	-	-	-	-	-	-
B-J	V2 21204-045-21		ISI-21204-045	ISI	-	-	-	-	-	-	-
B9.11	21204-045-21		6" ELBOW TO PIPE	AUG	-	-	-	-	-	-	-
1	1204			OWN	-	-	-	-	-	-	-
				PRE	-	-	-	-	-	-	-
B-J	V2 21204-045-22		ISI-21204-045	ISI	-	-	-	-	-	-	-
B9.11	21204-045-22		6" PIPE TO ELBOW	AUG	-	-	-	-	-	-	-
1	1204			OWN	-	-	-	-	-	-	-
				PRE	-	-	-	-	-	-	-
B-J	V2 21204-045-23		ISI-21204-045	ISI	-	-	-	-	-	-	-
B9.11	21204-045-23		6" ELBOW TO PIPE	AUG	-	-	-	-	-	-	-
1	1204			OWN	-	-	-	-	-	-	-
				PRE	-	-	-	-	-	-	-
B-J	V2 21204-045-24		ISI-21204-045	ISI	-	-	-	-	-	-	-
B9.11	21204-045-24		6" PIPE TO ELBOW	AUG	-	-	-	-	-	-	-
1	1204			OWN	-	-	-	-	-	-	-
				PRE	-	-	-	-	-	-	-
B-J	V2 21204-045-25		ISI-21204-045	ISI	-	-	-	-	-	-	-
B9.11	21204-045-25		6" ELBOW TO PIPE	AUG	-	-	-	-	-	-	-
1	1204			OWN	-	-	-	-	-	-	-
				PRE	-	-	-	-	-	-	-
B-J	V2 21204-045-26		ISI-21204-045	ISI	-	-	-	-	-	-	-
B9.11	21204-045-26		6" PIPE TO ELBOW	AUG	-	-	-	-	-	-	-
1	1204			OWN	-	-	-	-	-	-	-
				PRE	-	-	-	-	-	-	-
B-J	V2 21204-045-27		ISI-21204-045	ISI	-	-	-	-	-	-	-
B9.11	21204-045-27		6" ELBOW TO PIPE	AUG	-	-	-	-	-	-	-
1	1204			OWN	-	-	-	-	-	-	-
				PRE	-	-	-	-	-	-	-
B-J	V2 21204-045-28	ISI/UT/	ISI-21204-045	ISI	-	-	-	-	-	s	-
B9.11	21204-045-28		6" PIPE TO TEE	AUG	-	-	-	-	-	-	-
1	1204			OWN	-	-	-	-	-	-	-
				PRE	-	-	-	-	-	-	-
B-J	V2 21204-045-3		ISI-21204-045	ISI	-	-	-	-	-	-	-
B9.11	21204-045-3		6" PIPE TO ELBOW	AUG	-	-	-	-	-	-	-

Southern Nuclear Operating Company
3rd Interval
VOGTLE-2 ISI PLAN, VERSION 3.0

Category, Item No., Class	Summary No./CompID/System	Scope / Method / Procedure	Dwg/ISO No. Comp. Desc. Code Case		Period 1		Period 2		Period 3	
					2VR13	2VR14	2VR14A	2VR15	2VR16	2VR17
1	1204			OWN PRE	-	-	-	-	-	-
B-J B9.11 1	V2 21204-045-4 21204-045-4 1204		ISI-21204-045 6" ELBOW TO PIPE	ISI AUG OWN PRE	-	-	-	-	-	-
B-J B9.11 1	V2 21204-045-5 21204-045-5 1204		ISI-21204-045 6" PIPE TO ELBOW	ISI AUG OWN PRE	-	-	-	-	-	-
B-J B9.11 1	V2 21204-045-6 21204-045-6 1204		ISI-21204-045 6" ELBOW TO PIPE	ISI AUG OWN PRE	-	-	-	-	-	-
B-J B9.11 1	V2 21204-045-7 21204-045-7 1204		ISI-21204-045 6" PIPE TO ELBOW	ISI AUG OWN PRE	-	-	-	-	-	-
B-J B9.11 1	V2 21204-045-8 21204-045-8 1204		ISI-21204-045 6" ELBOW TO PIPE	ISI AUG OWN PRE	-	-	-	-	-	-
B-J B9.11 1	V2 21204-045-9 21204-045-9 1204		ISI-21204-045 6" PIPE TO ELBOW	ISI AUG OWN PRE	-	-	-	-	-	-
B-J B9.11 1	V2 21204-124-1 21204-124-1 1204		ISI-21204-124 10" VALVE TO PIPE	ISI AUG OWN PRE	-	-	-	-	-	-
B-J B9.11 1	V2 21204-124-10 21204-124-10 1204		ISI-21204-124 10" ELBOW TO PIPE (AI 87-0131)	ISI AUG OWN PRE	-	-	-	-	-	-
B-J B9.11 1	V2 21204-124-11 21204-124-11 1204		ISI-21204-124 10" PIPE TO TEE (AI 87-0131)	ISI AUG OWN PRE	-	-	-	-	-	-
B-J B9.11	V2 21204-124-12 21204-124-12		ISI-21204-124 10" TEE TO PIPE	ISI AUG	-	-	-	-	-	-

Southern Nuclear Operating Company
3rd Interval
VOGTLE-2 ISI PLAN, VERSION 3.0

Category, Item No., Class	Summary No./ComplD/System	Scope / Method / Procedure	Dwg/ISO No. Comp. Desc. Code Case		Period 1		Period 2		Period 3	
					2VR13	2VR14	2VR14A	2VR15	2VR16	2VR17
	1204			OWN	-	-	-	-	-	-
	1204			PRE	-	-	-	-	-	-
B-J	V2 21204-124-13		ISI-21204-124	ISI	-	-	-	-	-	-
B9.11	21204-124-13		10" PIPE TO ELBOW	AUG	-	-	-	-	-	-
1	1204			OWN	-	-	-	-	-	-
	1204			PRE	-	-	-	-	-	-
B-J	V2 21204-124-14		ISI-21204-124	ISI	-	-	-	-	-	-
B9.11	21204-124-14		10" ELBOW TO PIPE	AUG	-	-	-	-	-	-
1	1204			OWN	-	-	-	-	-	-
	1204			PRE	-	-	-	-	-	-
B-J	V2 21204-124-15		ISI-21204-124	ISI	-	-	-	-	-	-
B9.11	21204-124-15		10" PIPE TO VALVE (AI 87-0131)	AUG	-	-	-	-	-	-
1	1204			OWN	-	-	-	-	-	-
	1204			PRE	-	-	-	-	-	-
B-J	V2 21204-124-16		ISI-21204-124	ISI	-	-	-	-	-	-
B9.11	21204-124-16		10" VALVE TO PIPE (AI 87-0131)	AUG	-	-	-	-	-	-
1	1204			OWN	-	-	-	-	-	-
	1204			PRE	-	-	-	-	-	-
B-J	V2 21204-124-17		ISI-21204-124	ISI	-	-	-	-	-	-
B9.11	21204-124-17		10" PIPE TO ELBOW	AUG	-	-	-	-	-	-
1	1204			OWN	-	-	-	-	-	-
	1204			PRE	-	-	-	-	-	-
B-J	V2 21204-124-18	ISI/UT/	ISI-21204-124	ISI	-	-	-	-	s	-
B9.11	21204-124-18		10" ELBOW TO BRANCH CONNECTION	AUG	-	-	-	-	-	-
1	1204		(AI 87-0131)	OWN	-	-	-	-	-	-
	1204			PRE	-	-	-	-	-	-
B-J	V2 21204-124-2		ISI-21204-124	ISI	-	-	-	-	-	-
B9.11	21204-124-2		10" PIPE TO ELBOW	AUG	-	-	-	-	-	-
1	1204			OWN	-	-	-	-	-	-
	1204			PRE	-	-	-	-	-	-
B-J	V2 21204-124-3		ISI-21204-124	ISI	-	-	-	-	-	-
B9.11	21204-124-3		10" ELBOW TO PIPE	AUG	-	-	-	-	-	-
1	1204			OWN	-	-	-	-	-	-
	1204			PRE	-	-	-	-	-	-
B-J	V2 21204-124-4		ISI-21204-124	ISI	-	-	-	-	-	-
B9.11	21204-124-4		10" PIPE TO ELBOW	AUG	-	-	-	-	-	-
1	1204			OWN	-	-	-	-	-	-
	1204			PRE	-	-	-	-	-	-
B-J	V2 21204-124-5		ISI-21204-124	ISI	-	-	-	-	-	-

Southern Nuclear Operating Company
3rd Interval
VOGTLE-2 ISI PLAN, VERSION 3.0

Category, Item No., Class	Summary No./ComplD/System	Scope / Method / Procedure	Dwg/ISO No. Comp. Desc. Code Case		Period 1		Period 2			Period 3	
					2VR13	2VR14	2VR14A	2VR15	2VR16	2VR17	2VR18
B9.11 1	21204-124-5 1204		10" ELBOW TO PIPE	AUG OWN PRE	-	-	-	-	-	-	-
B-J B9.11 1	V2 21204-124-6 21204-124-6 1204		10" PIPE TO PIPE	ISI AUG OWN PRE	-	-	-	-	-	-	-
B-J B9.11 1	V2 21204-124-6 A 21204-124-6 A 1204		10" PIPE TO PIPE	ISI AUG OWN PRE	-	-	-	-	-	-	-
B-J B9.11 1	V2 21204-124-6 B 21204-124-6 B 1204		10" PIPE TO PIPE	ISI AUG OWN PRE	-	-	-	-	-	-	-
B-J B9.11 1	V2 21204-124-7 21204-124-7 1204		10" PIPE TO VALVE	ISI AUG OWN PRE	-	-	-	-	-	-	-
B-J B9.11 1	V2 21204-124-8 21204-124-8 1204		10" VALVE TO PIPE	ISI AUG OWN PRE	-	-	-	-	-	-	-
B-J B9.11 1	V2 21204-124-9 21204-124-9 1204		10" PIPE TO ELBOW	ISI AUG OWN PRE	-	-	-	-	-	-	-
B-J B9.11 1	V2 21204-125-1 21204-125-1 1204		10" VALVE TO PIPE	ISI AUG OWN PRE	-	-	-	-	-	-	-
B-J B9.11 1	V2 21204-125-10 21204-125-10 1204		10" ELBOW TO PIPE	ISI AUG OWN PRE	-	-	-	-	-	-	-
B-J B9.11 1	V2 21204-125-11 21204-125-11 1204		10" PIPE TO TEE	ISI AUG OWN PRE	-	-	-	-	-	-	-
B-J	V2 21204-125-12		ISI-21204-125	ISI	-	-	-	-	-	-	-

**Southern Nuclear Operating Company
3rd Interval
VOGTLE-2 ISI PLAN, VERSION 3.0**

Category, Item No., Class	Summary No./CompID/System	Scope / Method / Procedure	Dwg/ISO No. Comp. Desc. Code Case		Period 1		Period 2		Period 3	
					2VR13	2VR14	2VR14A	2VR15	2VR16	2VR17
B9.11 1	21204-125-12 1204		10" TEE TO PIPE	AUG OWN PRE	- - -	- - -	- - -	- - -	- - -	- - -
B-J B9.11 1	V2 21204-125-13 21204-125-13 1204		10" PIPE TO ELBOW	ISI AUG OWN PRE	- - - -	- - - -	- - - -	- - - -	- - - -	- - - -
B-J B9.11 1	V2 21204-125-14 21204-125-14 1204		10" ELBOW TO PIPE	ISI AUG OWN PRE	- - - -	- - - -	- - - -	- - - -	- - - -	- - - -
B-J B9.11 1	V2 21204-125-15 21204-125-15 1204		10" PIPE TO VALVE (AI 87-0131)	ISI AUG OWN PRE	- - - -	- - - -	- - - -	- - - -	- - - -	- - - -
B-J B9.11 1	V2 21204-125-16 21204-125-16 1204		10" VALVE TO PIPE (AI 87-0131)	ISI AUG OWN PRE	- - - -	- - - -	- - - -	- - - -	- - - -	- - - -
B-J B9.11 1	V2 21204-125-17 21204-125-17 1204		10" PIPE TO ELBOW	ISI AUG OWN PRE	- - - -	- - - -	- - - -	- - - -	- - - -	- - - -
B-J B9.11 1	V2 21204-125-18 21204-125-18 1204	ISI/UT/	10" ELBOW TO BRANCH CONNECTION (AI 87-0131)	ISI AUG OWN PRE	- - - -	- - - -	- - - -	- - - -	s - - -	- - - -
B-J B9.11 1	V2 21204-125-2 21204-125-2 1204	ISI/UT/	10" PIPE TO ELBOW	ISI AUG OWN PRE	- - - -	- - - -	- - - -	- - - -	s - - -	- - - -
B-J B9.11 1	V2 21204-125-3 21204-125-3 1204	ISI/UT/	10" ELBOW TO PIPE	ISI AUG OWN PRE	- - - -	- - - -	- - - -	- - - -	s - - -	- - - -
B-J B9.11 1	V2 21204-125-4 21204-125-4 1204		10" PIPE TO ELBOW	ISI AUG OWN PRE	- - - -	- - - -	- - - -	- - - -	- - - -	- - - -

Southern Nuclear Operating Company
3rd Interval
VOGTLE-2 ISI PLAN, VERSION 3.0

Category, Item No., Class	Summary No./CompID/System	Scope / Method / Procedure	Dwg/ISO No. Comp. Desc. Code Case		Period 1		Period 2		Period 3	
					2VR13	2VR14	2VR14A	2VR15	2VR16	2VR17
B-J	V2 21204-125-5		ISI-21204-125	ISI	-	-	-	-	-	-
B9.11	21204-125-5		10" ELBOW TO PIPE	AUG	-	-	-	-	-	-
1	1204			OWN	-	-	-	-	-	-
				PRE	-	-	-	-	-	-
B-J	V2 21204-125-6		ISI-21204-125	ISI	-	-	-	-	-	-
B9.11	21204-125-6		10" PIPE TO PIPE	AUG	-	-	-	-	-	-
1	1204			OWN	-	-	-	-	-	-
				PRE	-	-	-	-	-	-
B-J	V2 21204-125-7		ISI-21204-125	ISI	-	-	-	-	-	-
B9.11	21204-125-7		10" PIPE TO VALVE	AUG	-	-	-	-	-	-
1	1204			OWN	-	-	-	-	-	-
				PRE	-	-	-	-	-	-
B-J	V2 21204-125-8		ISI-21204-125	ISI	-	-	-	-	-	-
B9.11	21204-125-8		10" VALVE TO PIPE	AUG	-	-	-	-	-	-
1	1204			OWN	-	-	-	-	-	-
				PRE	-	-	-	-	-	-
B-J	V2 21204-125-9		ISI-21204-125	ISI	-	-	-	-	-	-
B9.11	21204-125-9		10" PIPE TO ELBOW	AUG	-	-	-	-	-	-
1	1204			OWN	-	-	-	-	-	-
				PRE	-	-	-	-	-	-
B-J	V2 21204-126-1		ISI-21204-126	ISI	-	-	-	-	-	-
B9.11	21204-126-1		10" VALVE TO PIPE	AUG	-	-	-	-	-	-
1	1204			OWN	-	-	-	-	-	-
				PRE	-	-	-	-	-	-
B-J	V2 21204-126-10		ISI-21204-126	ISI	-	-	-	-	-	-
B9.11	21204-126-10		10" ELBOW TO PIPE	AUG	-	-	-	-	-	-
1	1204			OWN	-	-	-	-	-	-
				PRE	-	-	-	-	-	-
B-J	V2 21204-126-11		ISI-21204-126	ISI	-	-	-	-	-	-
B9.11	21204-126-11		10" PIPE TO TEE (AI 87-0131)	AUG	-	-	-	-	-	-
1	1204			OWN	-	-	-	-	-	-
				PRE	-	-	-	-	-	-
B-J	V2 21204-126-12		ISI-21204-126	ISI	-	-	-	-	-	-
B9.11	21204-126-12		10" TEE TO PIPE (AI 87-0131)	AUG	-	-	-	-	-	-
1	1204			OWN	-	-	-	-	-	-
				PRE	-	-	-	-	-	-
B-J	V2 21204-126-13		ISI-21204-126	ISI	-	-	-	-	-	-
B9.11	21204-126-13		10" PIPE TO ELBOW	AUG	-	-	-	-	-	-
1	1204			OWN	-	-	-	-	-	-
				PRE	-	-	-	-	-	-

**Southern Nuclear Operating Company
3rd Interval
VOGTLE-2 ISI PLAN, VERSION 3.0**

Category, Item No., Class	Summary No./CompID/System	Scope / Method / Procedure	Dwg/ISO No. Comp. Desc. Code Case		Period 1		Period 2		Period 3										
					2VR13	2VR14	2VR14A	2VR15	2VR16	2VR17	2VR18								
B-J B9.11 1	V2 21204-126-14 21204-126-14 1204		ISI-21204-126 10" ELBOW TO PIPE	ISI AUG OWN PRE	-	-	-	-	-	-	-	-	-	-	-	-	-	-	-
B-J B9.11 1	V2 21204-126-15 21204-126-15 1204		ISI-21204-126 10" PIPE TO VALVE (AI 87-0131)	ISI AUG OWN PRE	-	-	-	-	-	-	-	-	-	-	-	-	-	-	-
B-J B9.11 1	V2 21204-126-16 21204-126-16 1204		ISI-21204-126 10" VALVE TO PIPE (AI 87-0131)	ISI AUG OWN PRE	-	-	-	-	-	-	-	-	-	-	-	-	-	-	-
B-J B9.11 1	V2 21204-126-17 21204-126-17 1204		ISI-21204-126 10" PIPE TO ELBOW	ISI AUG OWN PRE	-	-	-	-	-	-	-	-	-	-	-	-	-	-	-
B-J B9.11 1	V2 21204-126-18 21204-126-18 1204	ISI/UT/	ISI-21204-126 10" ELBOW TO BRANCH CONNECTION (AI 87-0131)	ISI AUG OWN PRE	-	-	-	-	-	-	-	-	-	-	-	-	-	-	s
B-J B9.11 1	V2 21204-126-2 21204-126-2 1204	ISI/UT/	ISI-21204-126 10" PIPE TO ELBOW	ISI AUG OWN PRE	-	-	-	-	-	-	s	-	-	-	-	-	-	-	-
B-J B9.11 1	V2 21204-126-3 21204-126-3 1204	ISI/UT/	ISI-21204-126 10" ELBOW TO PIPE	ISI AUG OWN PRE	-	-	-	-	-	-	s	-	-	-	-	-	-	-	-
B-J B9.11 1	V2 21204-126-4 21204-126-4 1204		ISI-21204-126 10" PIPE TO ELBOW	ISI AUG OWN PRE	-	-	-	-	-	-	-	-	-	-	-	-	-	-	-
B-J B9.11 1	V2 21204-126-5 21204-126-5 1204		ISI-21204-126 10" ELBOW TO PIPE	ISI AUG OWN PRE	-	-	-	-	-	-	-	-	-	-	-	-	-	-	-
B-J B9.11 1	V2 21204-126-6 21204-126-6 1204		ISI-21204-126 10" PIPE TO PIPE	ISI AUG OWN	-	-	-	-	-	-	-	-	-	-	-	-	-	-	-

Southern Nuclear Operating Company
3rd Interval
VOGTLE-2 ISI PLAN, VERSION 3.0

Category, Item No., Class	Summary No./ComplID/System	Scope / Method / Procedure	Dwg/ISO No. Comp. Desc. Code Case		Period 1		Period 2		Period 3	
					2VR13	2VR14	2VR14A	2VR15	2VR16	2VR17
				PRE	-	-	-	-	-	-
B-J	V2 21204-126-7	ISI/UT/	ISI-21204-126	ISI	-	-	-	-	-	s
B9.11	21204-126-7		10" PIPE TO VALVE	AUG	-	-	-	-	-	-
1	1204			OWN	-	-	-	-	-	-
				PRE	-	-	-	-	-	-
B-J	V2 21204-126-8	ISI/UT/	ISI-21204-126	ISI	-	-	-	-	-	s
B9.11	21204-126-8		10" VALVE TO PIPE	AUG	-	-	-	-	-	-
1	1204			OWN	-	-	-	-	-	-
				PRE	-	-	-	-	-	-
B-J	V2 21204-126-9	ISI/UT/	ISI-21204-126	ISI	-	-	-	-	-	s
B9.11	21204-126-9		10" PIPE TO ELBOW	AUG	-	-	-	-	-	-
1	1204			OWN	-	-	-	-	-	-
				PRE	-	-	-	-	-	-
B-J	V2 21204-127-1		ISI-21204-127	ISI	-	-	-	-	-	-
B9.11	21204-127-1		10" VALVE TO PIPE	AUG	-	-	-	-	-	-
1	1204			OWN	-	-	-	-	-	-
				PRE	-	-	-	-	-	-
B-J	V2 21204-127-10		ISI-21204-127	ISI	-	-	-	-	-	-
B9.11	21204-127-10		10" ELBOW TO PIPE	AUG	-	-	-	-	-	-
1	1204			OWN	-	-	-	-	-	-
				PRE	-	-	-	-	-	-
B-J	V2 21204-127-11		ISI-21204-127	ISI	-	-	-	-	-	-
B9.11	21204-127-11		10" PIPE TO ELBOW	AUG	-	-	-	-	-	-
1	1204			OWN	-	-	-	-	-	-
				PRE	-	-	-	-	-	-
B-J	V2 21204-127-12		ISI-21204-127	ISI	-	-	-	-	-	-
B9.11	21204-127-12		10" ELBOW TO PIPE	AUG	-	-	-	-	-	-
1	1204			OWN	-	-	-	-	-	-
				PRE	-	-	-	-	-	-
B-J	V2 21204-127-13		ISI-21204-127	ISI	-	-	-	-	-	-
B9.11	21204-127-13		10" PIPE TO TEE	AUG	-	-	-	-	-	-
1	1204			OWN	-	-	-	-	-	-
				PRE	-	-	-	-	-	-
B-J	V2 21204-127-14		ISI-21204-127	ISI	-	-	-	-	-	-
B9.11	21204-127-14		10" TEE TO PIPE	AUG	-	-	-	-	-	-
1	1204			OWN	-	-	-	-	-	-
				PRE	-	-	-	-	-	-
B-J	V2 21204-127-15		ISI-21204-127	ISI	-	-	-	-	-	-
B9.11	21204-127-15		10" PIPE TO ELBOW	AUG	-	-	-	-	-	-
1	1204			OWN	-	-	-	-	-	-

**Southern Nuclear Operating Company
3rd Interval
VOGTLE-2 ISI PLAN, VERSION 3.0**

Category, Item No., Class	Summary No./CompID/System	Scope / Method / Procedure	Dwg/ISO No. Comp. Desc. Code Case		Period 1		Period 2		Period 3	
					2VR13	2VR14	2VR14A	2VR15	2VR16	2VR17
				PRE	-	-	-	-	-	-
B-J	V2 21204-127-16		ISI-21204-127	ISI	-	-	-	-	-	-
B9.11	21204-127-16		10" ELBOW TO PIPE	AUG	-	-	-	-	-	-
1	1204			OWN	-	-	-	-	-	-
				PRE	-	-	-	-	-	-
B-J	V2 21204-127-17		ISI-21204-127	ISI	-	-	-	-	-	-
B9.11	21204-127-17		10" PIPE TO ELBOW	AUG	-	-	-	-	-	-
1	1204			OWN	-	-	-	-	-	-
				PRE	-	-	-	-	-	-
B-J	V2 21204-127-18	ISI/UT/	ISI-21204-127	ISI	-	-	-	-	s	-
B9.11	21204-127-18		10" ELBOW TO PIPE (AI 87-0131)	AUG	-	-	-	-	-	-
1	1204			OWN	-	-	-	-	-	-
				PRE	-	-	-	-	-	-
B-J	V2 21204-127-19	ISI/UT/	ISI-21204-127	ISI	-	-	-	-	s	-
B9.11	21204-127-19		10" PIPE TO VALVE (AI 87-0131)	AUG	-	-	-	-	-	-
1	1204			OWN	-	-	-	-	-	-
				PRE	-	-	-	-	-	-
B-J	V2 21204-127-2	ISI/UT/	ISI-21204-127	ISI	-	-	-	s	-	-
B9.11	21204-127-2		10" PIPE TO ELBOW	AUG	-	-	-	-	-	-
1	1204			OWN	-	-	-	-	-	-
				PRE	-	-	-	-	-	-
B-J	V2 21204-127-20	ISI/UT/	ISI-21204-127	ISI	-	-	-	s	-	-
B9.11	21204-127-20		10" VALVE TO PIPE (AI 87-0131)	AUG	-	-	-	-	-	-
1	1204			OWN	-	-	-	-	-	-
				PRE	-	-	-	-	-	-
B-J	V2 21204-127-21		ISI-21204-127	ISI	-	-	-	-	-	-
B9.11	21204-127-21		10" PIPE TO ELBOW	AUG	-	-	-	-	-	-
1	1204			OWN	-	-	-	-	-	-
				PRE	-	-	-	-	-	-
B-J	V2 21204-127-22	ISI/UT/	ISI-21204-127	ISI	-	-	-	s	-	-
B9.11	21204-127-22		10" ELBOW TO BRANCH CONNECTION (AI 87-0131)	AUG	-	-	-	-	-	-
1	1204			OWN	-	-	-	-	-	-
				PRE	-	-	-	-	-	-
B-J	V2 21204-127-3	ISI/UT/	ISI-21204-127	ISI	-	-	-	s	-	-
B9.11	21204-127-3		10" ELBOW TO PIPE	AUG	-	-	-	-	-	-
1	1204			OWN	-	-	-	-	-	-
				PRE	-	-	-	-	-	-
B-J	V2 21204-127-4		ISI-21204-127	ISI	-	-	-	-	-	-
B9.11	21204-127-4		10" PIPE TO ELBOW	AUG	-	-	-	-	-	-

Southern Nuclear Operating Company
3rd Interval
VOGTLE-2 ISI PLAN, VERSION 3.0

Category, Item No., Class	Summary No./CompID/System	Scope / Method / Procedure	Dwg/ISO No. Comp. Desc. Code Case		Period 1		Period 2			Period 3	
					2VR13	2VR14	2VR14A	2VR15	2VR16	2VR17	2VR18
1	1204			OWN PRE	-	-	-	-	-	-	-
B-J B9.11 1	V2 21204-127-5 21204-127-5 1204		ISI-21204-127 10" ELBOW TO PIPE	ISI AUG OWN PRE	-	-	-	-	-	-	-
B-J B9.11 1	V2 21204-127-6 21204-127-6 1204		ISI-21204-127 10" PIPE TO PIPE	ISI AUG OWN PRE	-	-	-	-	-	-	-
B-J B9.11 1	V2 21204-127-7 21204-127-7 1204		ISI-21204-127 10" PIPE TO VALVE	ISI AUG OWN PRE	-	-	-	-	-	-	-
B-J B9.11 1	V2 21204-127-8 21204-127-8 1204	ISI/UT/	ISI-21204-127 10" VALVE TO PIPE	ISI AUG OWN PRE	-	-	-	s	-	-	-
B-J B9.11 1	V2 21204-127-9 21204-127-9 1204	ISI/UT/	ISI-21204-127 10" PIPE TO ELBOW	ISI AUG OWN PRE	-	-	-	s	-	-	-
B-J B9.21 1	V2 21201-005-9 21201-005-9 1201		ISI-21201-005 3" PIPE CAP TO BRANCH CONNECTION	ISI AUG OWN PRE	-	-	-	-	-	-	-
B-J B9.21 1	V2 21201-006-9 21201-006-9 1201		ISI-21201-006 3" PIPE CAP TO BRANCH CONNECTION	ISI AUG OWN PRE	-	-	-	-	-	-	-
B-J B9.21 1	V2 21201-007-9 21201-007-9 1201		ISI-21201-007 3" PIPE CAP TO BRANCH CONNECTION	ISI AUG OWN PRE	-	-	-	-	-	-	-
B-J B9.21 1	V2 21201-008-9 21201-008-9 1201		ISI-21201-008 3" PIPE CAP TO BRANCH CONNECTION	ISI AUG OWN PRE	-	-	-	-	-	-	-
B-J B9.21	V2 21201-031-10 21201-031-10		ISI-21201-031 1.5" REDUCER TO FLOW RESTRICTOR	ISI AUG	-	-	-	-	-	-	-

Southern Nuclear Operating Company
3rd Interval
VOGTLE-2 ISI PLAN, VERSION 3.0

Category, Item No., Class	Summary No./ComplID/System	Scope / Method / Procedure	Dwg/ISO No. Comp. Desc. Code Case		Period 1		Period 2			Period 3	
					2VR13	2VR14	2VR14A	2VR15	2VR16	2VR17	2VR18
	1201			OWN	-	-	-	-	-	-	-
				PRE	-	-	-	-	-	-	-
B-J	V2 21201-031-2	ISI/PT/	ISI-21201-031	ISI	-	-	-	-	-	s	-
B9.21	21201-031-2		2" PIPE TO ELBOW	AUG	-	-	-	-	-	-	-
1	1201			OWN	-	-	-	-	-	-	-
				PRE	-	-	-	-	-	-	-
B-J	V2 21201-031-3	ISI/UT/NMP-ES-024-501	ISI-21201-031	ISI	B	-	-	-	-	-	-
B9.21	21201-031-3		2" ELBOW TO PIPE	AUG	-	-	-	-	-	-	-
1	1201			OWN	-	-	-	-	-	-	-
				PRE	-	-	-	-	-	-	-
B-J	V2 21201-031-6		ISI-21201-031	ISI	-	-	-	-	-	-	-
B9.21	21201-031-6		2" PIPE TO TEE	AUG	-	-	-	-	-	-	-
1	1201			OWN	-	-	-	-	-	-	-
				PRE	-	-	-	-	-	-	-
B-J	V2 21201-031-7		ISI-21201-031	ISI	-	-	-	-	-	-	-
B9.21	21201-031-7		2" TEE TO PIPE	AUG	-	-	-	-	-	-	-
1	1201			OWN	-	-	-	-	-	-	-
				PRE	-	-	-	-	-	-	-
B-J	V2 21201-031-9		ISI-21201-031	ISI	-	-	-	-	-	-	-
B9.21	21201-031-9		2" TEE TO REDUCER	AUG	-	-	-	-	-	-	-
1	1201			OWN	-	-	-	-	-	-	-
				PRE	-	-	-	-	-	-	-
B-J	V2 21201-042-2		ISI-21201-042	ISI	-	-	-	-	-	-	-
B9.21	21201-042-2		2" PIPE TO ELBOW	AUG	-	-	-	-	-	-	-
1	1201			OWN	-	-	-	-	-	-	-
				PRE	-	-	-	-	-	-	-
B-J	V2 21201-042-3	ISI/UT/NMP-ES-024-501	ISI-21201-042	ISI	B	-	-	-	-	-	-
B9.21	21201-042-3		2" ELBOW TO PIPE	AUG	-	-	-	-	-	-	-
1	1201			OWN	-	-	-	-	-	-	-
				PRE	-	-	-	-	-	-	-
B-J	V2 21201-046-2	ISI/PT/	ISI-21201-046	ISI	-	-	-	-	-	s	-
B9.21	21201-046-2		2" PIPE TO ELBOW	AUG	-	-	-	-	-	-	-
1	1201			OWN	-	-	-	-	-	-	-
				PRE	-	-	-	-	-	-	-
B-J	V2 21201-046-3	ISI/UT/NMP-ES-024-501	ISI-21201-046	ISI	B	-	-	-	-	-	-
B9.21	21201-046-3		2" ELBOW TO PIPE	AUG	-	-	-	-	-	-	-
1	1201			OWN	-	-	-	-	-	-	-
				PRE	-	-	-	-	-	-	-
B-J	V2 21201-048-1	ISI/UT/	ISI-21201-048	ISI	-	-	-	-	-	s	-

Southern Nuclear Operating Company
3rd Interval
VOGTLE-2 ISI PLAN, VERSION 3.0

Category, Item No., Class	Summary No./CompID/System	Scope / Method / Procedure	Dwg/ISO No. Comp. Desc. Code Case		Period 1		Period 2		Period 3	
					2VR13	2VR14	2VR14A	2VR15	2VR16	2VR17
B9.21 1	21201-048-1 1201		3" BRANCH CONNECTION TO PIPE (AI 87-0131)	AUG OWN PRE	-	-	-	-	-	-
B-J B9.21 1	V2 21201-048-10 21201-048-10 1201	ISI/PT/NMP-ES-024-301	ISI-21201-048 3" PIPE TO VALVE (AI 87-0131)	ISI AUG OWN PRE	-	-	-	-	s	-
B-J B9.21 1	V2 21201-048-2 21201-048-2 1201	ISI/PT/NMP-ES-024-301	ISI-21201-048 3" PIPE TO ELBOW	ISI AUG OWN PRE	-	-	-	-	s	-
B-J B9.21 1	V2 21201-048-3 21201-048-3 1201		ISI-21201-048 3" ELBOW TO PIPE	ISI AUG OWN PRE	-	-	-	-	-	-
B-J B9.21 1	V2 21201-048-4 21201-048-4 1201	ISI/PT/	ISI-21201-048 3" PIPE TO ELBOW	ISI AUG OWN PRE	-	-	s	-	-	-
B-J B9.21 1	V2 21201-048-5 21201-048-5 1201		ISI-21201-048 3" ELBOW TO PIPE	ISI AUG OWN PRE	-	-	-	-	-	-
B-J B9.21 1	V2 21201-048-6 21201-048-6 1201		ISI-21201-048 3" PIPE TO VALVE	ISI AUG OWN PRE	-	-	-	-	-	-
B-J B9.21 1	V2 21201-048-7 21201-048-7 1201		ISI-21201-048 3" VALVE TO PIPE	ISI AUG OWN PRE	-	-	-	-	-	-
B-J B9.21 1	V2 21201-048-8 21201-048-8 1201		ISI-21201-048 3" PIPE TO ELBOW	ISI AUG OWN PRE	-	-	-	-	-	-
B-J B9.21 1	V2 21201-048-9 21201-048-9 1201		ISI-21201-048 3" ELBOW TO PIPE	ISI AUG OWN PRE	-	-	-	-	-	-

**Southern Nuclear Operating Company
3rd Interval
VOGTLE-2 ISI PLAN, VERSION 3.0**

Category, Item No., Class	Summary No./CompID/System	Scops / Method / Procedure	Dwg/ISO No. Comp. Desc. Code Case		Period 1		Period 2			Period 3	
					2VR13	2VR14	2VR14A	2VR15	2VR16	2VR17	2VR18
B-J	V2 21201-048-9 A		ISI-21201-048	ISI	-	-	-	-	-	-	-
B9.21	21201-048-9 A		3" PIPE TO PIPE	AUG	-	-	-	-	-	-	-
1	1201			OWN	-	-	-	-	-	-	-
				PRE	-	-	-	-	-	-	-
B-J	V2 21201-049-9		ISI-21201-049	ISI	-	-	-	-	-	-	-
B9.21	21201-049-9		2" WELDOLET TO CAP	AUG	-	-	-	-	-	-	-
1	1201			OWN	-	-	-	-	-	-	-
				PRE	-	-	-	-	-	-	-
B-J	V2 21201-050-1	ISI/PT/	ISI-21201-050	ISI	-	-	-	s	-	-	-
B9.21	21201-050-1		2" BRANCH CONNECTION TO PIPE	AUG	-	-	-	-	-	-	-
1	1201			OWN	-	-	-	-	-	-	-
				PRE	-	-	-	-	-	-	-
B-J	V2 21201-051-2		ISI-21201-051	ISI	-	-	-	-	-	-	-
B9.21	21201-051-2		2" PIPE TO ELBOW	AUG	-	-	-	-	-	-	-
1	1201			OWN	-	-	-	-	-	-	-
				PRE	-	-	-	-	-	-	-
B-J	V2 21201-051-3	ISI/UT/NMP-ES-024-501	ISI-21201-051	ISI	B	-	-	-	-	-	-
B9.21	21201-051-3		2" ELBOW TO PIPE	AUG	-	-	-	-	-	-	-
1	1201			OWN	-	-	-	-	-	-	-
				PRE	-	-	-	-	-	-	-
B-J	V2 21201-051-4		ISI-21201-051	ISI	-	-	-	-	-	-	-
B9.21	21201-051-4		2" PIPE TO TEE	AUG	-	-	-	-	-	-	-
1	1201			OWN	-	-	-	-	-	-	-
				PRE	-	-	-	-	-	-	-
B-J	V2 21201-051-5		ISI-21201-051	ISI	-	-	-	-	-	-	-
B9.21	21201-051-5		2" TEE TO PIPE	AUG	-	-	-	-	-	-	-
1	1201			OWN	-	-	-	-	-	-	-
				PRE	-	-	-	-	-	-	-
B-J	V2 21201-059-14		ISI-21201-059	ISI	-	-	-	-	-	-	-
B9.21	21201-059-14		3" REDUCER TO ELBOW	AUG	-	-	-	-	-	-	-
1	1201			OWN	-	-	-	-	-	-	-
				PRE	-	-	-	-	-	-	-
B-J	V2 21201-059-15	ISI/PT/	ISI-21201-059	ISI	-	-	-	s	-	-	-
B9.21	21201-059-15		3" ELBOW TO ELBOW	AUG	-	-	-	-	-	-	-
1	1201			OWN	-	-	-	-	-	-	-
				PRE	-	-	-	-	-	-	-
B-J	V2 21201-059-16		ISI-21201-059	ISI	-	-	-	-	-	-	-
B9.21	21201-059-16		3" ELBOW TO PIPE	AUG	-	-	-	-	-	-	-
1	1201			OWN	-	-	-	-	-	-	-
				PRE	-	-	-	-	-	-	-

Southern Nuclear Operating Company
3rd Interval
VOGTLE-2 ISI PLAN, VERSION 3.0

Category, Item No., Class	Summary No./CompID/System	Scope / Method / Procedure	Dwg/ISO No. Comp. Desc. Code Case		Period 1		Period 2		Period 3	
					2VR13	2VR14	2VR14A	2VR15	2VR16	2VR17
B-J	V2 21201-059-17		ISI-21201-059	ISI	-	-	-	-	-	-
B9.21	21201-059-17		3" PIPE TO VALVE	AUG	-	-	-	-	-	-
1	1201			OWN	-	-	-	-	-	-
				PRE	-	-	-	-	-	-
B-J	V2 21201-059-18		ISI-21201-059	ISI	-	-	-	-	-	-
B9.21	21201-059-18		3" VALVE TO PIPE	AUG	-	-	-	-	-	-
1	1201			OWN	-	-	-	-	-	-
				PRE	-	-	-	-	-	-
B-J	V2 21201-059-19	ISI/PT/	ISI-21201-059	ISI	-	-	-	-	s	-
B9.21	21201-059-19		3" PIPE TO ELBOW	AUG	-	-	-	-	-	-
1	1201			OWN	-	-	-	-	-	-
				PRE	-	-	-	-	-	-
B-J	V2 21201-059-20		ISI-21201-059	ISI	-	-	-	-	-	-
B9.21	21201-059-20		3" ELBOW TO PIPE	AUG	-	-	-	-	-	-
1	1201			OWN	-	-	-	-	-	-
				PRE	-	-	-	-	-	-
B-J	V2 21201-059-21		ISI-21201-059	ISI	-	-	-	-	-	-
B9.21	21201-059-21		3" PIPE TO VALVE	AUG	-	-	-	-	-	-
1	1201			OWN	-	-	-	-	-	-
				PRE	-	-	-	-	-	-
B-J	V2 21201-060-10		ISI-21201-060	ISI	-	-	-	-	-	-
B9.21	21201-060-10		3" PIPE TO VALVE	AUG	-	-	-	-	-	-
1	1201			OWN	-	-	-	-	-	-
				PRE	-	-	-	-	-	-
B-J	V2 21201-060-3		ISI-21201-060	ISI	-	-	-	-	-	-
B9.21	21201-060-3		3" REDUCER TO ELBOW	AUG	-	-	-	-	-	-
1	1201			OWN	-	-	-	-	-	-
				PRE	-	-	-	-	-	-
B-J	V2 21201-060-4		ISI-21201-060	ISI	-	-	-	-	-	-
B9.21	21201-060-4		3" ELBOW TO ELBOW	AUG	-	-	-	-	-	-
1	1201			OWN	-	-	-	-	-	-
				PRE	-	-	-	-	-	-
B-J	V2 21201-060-5		ISI-21201-060	ISI	-	-	-	-	-	-
B9.21	21201-060-5		3" ELBOW TO PIPE	AUG	-	-	-	-	-	-
1	1201			OWN	-	-	-	-	-	-
				PRE	-	-	-	-	-	-
B-J	V2 21201-060-6	ISI/PT/	ISI-21201-060	ISI	-	-	-	s	-	-
B9.21	21201-060-6		3" PIPE TO VALVE	AUG	-	-	-	-	-	-
1	1201			OWN	-	-	-	-	-	-
				PRE	-	-	-	-	-	-

Southern Nuclear Operating Company
3rd Interval
VOGTLE-2 ISI PLAN, VERSION 3.0

Category, Item No., Class	Summary No./CompID/System	Scope / Method / Procedure	Dwg/ISO No. Comp. Desc. Code Case		Period 1		Period 2		Period 3	
					2VR13	2VR14	2VR14A	2VR15	2VR16	2VR17
B-J	V2 21201-060-7	ISI/PT/	ISI-21201-060	ISI	-	-	-	s	-	-
B9.21	21201-060-7		3' VALVE TO PIPE	AUG	-	-	-	-	-	-
1	1201			OWN	-	-	-	-	-	-
				PRE	-	-	-	-	-	-
B-J	V2 21201-060-8	ISI/PT/	ISI-21201-060	ISI	-	-	-	s	-	-
B9.21	21201-060-8		3' PIPE TO ELBOW	AUG	-	-	-	-	-	-
1	1201			OWN	-	-	-	-	-	-
				PRE	-	-	-	-	-	-
B-J	V2 21201-060-9		ISI-21201-060	ISI	-	-	-	-	-	-
B9.21	21201-060-9		3' ELBOW TO PIPE	AUG	-	-	-	-	-	-
1	1201			OWN	-	-	-	-	-	-
				PRE	-	-	-	-	-	-
B-J	V2 21201-208-1	ISI/PT/	ISI-21201-208	ISI	-	-	-	s	-	-
B9.21	21201-208-1		2" BRANCH CONNECTION TO PIPE	AUG	-	-	-	-	-	-
1	1201			OWN	-	-	-	-	-	-
				PRE	-	-	-	-	-	-
B-J	V2 21204-018-2		ISI-21204-018	ISI	-	-	-	-	-	-
B9.21	21204-018-2		2" PIPE TO ELBOW	AUG	-	-	-	-	-	-
1	1204			OWN	-	-	-	-	-	-
				PRE	-	-	-	-	-	-
B-J	V2 21204-018-3		ISI-21204-018	ISI	-	-	-	-	-	-
B9.21	21204-018-3		2" ELBOW TO PIPE	AUG	-	-	-	-	-	-
1	1204			OWN	-	-	-	-	-	-
				PRE	-	-	-	-	-	-
B-J	V2 21204-018-4	ISI/PT/	ISI-21204-018	ISI	-	-	-	s	-	-
B9.21	21204-018-4		2" PIPE TO BRANCH CONNECTION	AUG	-	-	-	-	-	-
1	1204			OWN	-	-	-	-	-	-
				PRE	-	-	-	-	-	-
B-J	V2 21204-022-2		ISI-21204-022	ISI	-	-	-	-	-	-
B9.21	21204-022-2		2" PIPE TO ELBOW	AUG	-	-	-	-	-	-
1	1204			OWN	-	-	-	-	-	-
				PRE	-	-	-	-	-	-
B-J	V2 21204-022-3		ISI-21204-022	ISI	-	-	-	-	-	-
B9.21	21204-022-3		2" ELBOW TO PIPE	AUG	-	-	-	-	-	-
1	1204			OWN	-	-	-	-	-	-
				PRE	-	-	-	-	-	-
B-J	V2 21204-022-4	ISI/PT/	ISI-21204-022	ISI	-	-	-	s	-	-
B9.21	21204-022-4		2" PIPE TO BRANCH CONNECTION	AUG	-	-	-	-	-	-
1	1204			OWN	-	-	-	-	-	-
				PRE	-	-	-	-	-	-

**Southern Nuclear Operating Company
3rd Interval
VOGTLE-2 ISI PLAN, VERSION 3.0**

Category, Item No., Class	Summary No./CompID/System	Scope / Method / Procedure	Dwg/ISO No. Comp. Desc. Code Case	Period 1		Period 2		Period 3	
				2VR13	2VR14	2VR14A	2VR15	2VR16	2VR17
B-J B9.21 1	V2 21204-024-10 21204-024-10 1204	ISI/PT/	ISI-21204-024 3" ELBOW TO PIPE	ISI AUG OWN PRE	- - - -	- - - -	- - - -	- - - -	s - - -
B-J B9.21 1	V2 21204-024-11 21204-024-11 1204	ISI/PT/	ISI-21204-024 3" PIPE TO REDUCER	ISI AUG OWN PRE	- - - -	- - - -	- - - -	- - - -	s - - -
B-J B9.21 1	V2 21204-024-2 21204-024-2 1204		ISI-21204-024 2" PIPE TO TEE	ISI AUG OWN PRE	- - - -	- - - -	- - - -	- - - -	- - - -
B-J B9.21 1	V2 21204-024-3 21204-024-3 1204	ISI/PT/	ISI-21204-024 2" TEE TO REDUCER	ISI AUG OWN PRE	- - - -	- - - -	- - - -	- - - -	s - - -
B-J B9.21 1	V2 21204-024-3 A 21204-024-3 A 1204		ISI-21204-024 1.5" REDUCER TO FLOW RESTRICTOR	ISI AUG OWN PRE	- - - -	- - - -	- - - -	- - - -	- - - -
B-J B9.21 1	V2 21204-024-4 21204-024-4 1204		ISI-21204-024 2" TEE TO PIPE	ISI AUG OWN PRE	- - - -	- - - -	- - - -	- - - -	- - - -
B-J B9.21 1	V2 21204-024-5 21204-024-5 1204		ISI-21204-024 2" PIPE TO PIPE	ISI AUG OWN PRE	- - - -	- - - -	- - - -	- - - -	- - - -
B-J B9.21 1	V2 21204-024-6 21204-024-6 1204		ISI-21204-024 2" PIPE TO PIPE	ISI AUG OWN PRE	- - - -	- - - -	- - - -	- - - -	- - - -
B-J B9.21 1	V2 21204-024-6 A 21204-024-6 A 1204		ISI-21204-024 2" PIPE TO PIPE	ISI AUG OWN PRE	- - - -	- - - -	- - - -	- - - -	- - - -
B-J B9.21 1	V2 21204-024-7 21204-024-7 1204		ISI-21204-024 2" PIPE TO REDUCER	ISI AUG OWN PRE	- - - -	- - - -	- - - -	- - - -	- - - -

**Southern Nuclear Operating Company
3rd Interval
VOGTLE-2 ISI PLAN, VERSION 3.0**

Category, Item No., Class	Summary No./CompID/System	Scope / Method / Procedure	Dwg/ISO No. Comp. Desc. Code Case		Period 1		Period 2		Period 3	
					2VR13	2VR14	2VR14A	2VR15	2VR16	2VR17
B-J B9.21 1	V2 21204-024-8 21204-024-8 1204	ISI/PT/	ISI-21204-024 3" REDUCER TO PIPE	ISI AUG OWN PRE	- - - -	- - - -	- - - -	- - - -	- - - -	s - - -
B-J B9.21 1	V2 21204-024-9 21204-024-9 1204		ISI-21204-024 3" PIPE TO ELBOW	ISI AUG OWN PRE	- - - -	- - - -	- - - -	- - - -	- - - -	- - - -
B-J B9.21 1	V2 21204-025-10 21204-025-10 1204		ISI-21204-025 2" ELBOW TO PIPE	ISI AUG OWN PRE	- - - -	- - - -	- - - -	- - - -	- - - -	- - - -
B-J B9.21 1	V2 21204-025-10 A 21204-025-10 A 1204		ISI-21204-025 2" PIPE TO PIPE	ISI AUG OWN PRE	- - - -	- - - -	- - - -	- - - -	- - - -	- - - -
B-J B9.21 1	V2 21204-025-11 21204-025-11 1204		ISI-21204-025 2" PIPE TO PIPE	ISI AUG OWN PRE	- - - -	- - - -	- - - -	- - - -	- - - -	- - - -
B-J B9.21 1	V2 21204-025-12 21204-025-12 1204		ISI-21204-025 2" PIPE TO REDUCER	ISI AUG OWN PRE	- - - -	- - - -	- - - -	- - - -	- - - -	- - - -
B-J B9.21 1	V2 21204-025-13 21204-025-13 1204		ISI-21204-025 3" REDUCER TO PIPE	ISI AUG OWN PRE	- - - -	- - - -	- - - -	- - - -	- - - -	- - - -
B-J B9.21 1	V2 21204-025-14 21204-025-14 1204	ISI/PT/	ISI-21204-025 3" PIPE TO REDUCER	ISI AUG OWN PRE	- - - -	- - - -	- - - -	- - - -	- - - -	s - - -
B-J B9.21 1	V2 21204-025-2 21204-025-2 1204	ISI/PT/	ISI-21204-025 2" PIPE TO TEE	ISI AUG OWN PRE	- - - -	- - - -	- - - -	- - - -	- - - -	s - - -
B-J B9.21 1	V2 21204-025-28 21204-025-28 1204		ISI-21204-025 2" TEE TO REDUCER	ISI AUG OWN PRE	- - - -	- - - -	- - - -	- - - -	- - - -	- - - -

Southern Nuclear Operating Company
3rd Interval
VOGTLE-2 ISI PLAN, VERSION 3.0

Category, Item No., Class	Summary No./CompID/System	Scope / Method / Procedure	Dwg/ISO No. Comp. Desc. Code Case		Period 1		Period 2		Period 3	
					2VR13	2VR14	2VR14A	2VR15	2VR16	2VR17
B-J	V2 21204-025-29		ISI-21204-025	ISI	-	-	-	-	-	-
B9.21	21204-025-29		1.5" REDUCER TO FLOW RESTRICTOR	AUG	-	-	-	-	-	-
1	1204			OWN	-	-	-	-	-	-
				PRE	-	-	-	-	-	-
B-J	V2 21204-025-3	ISI/PT/	ISI-21204-025	ISI	-	-	-	s	-	-
B9.21	21204-025-3		2" TEE TO PIPE	AUG	-	-	-	-	-	-
1	1204			OWN	-	-	-	-	-	-
				PRE	-	-	-	-	-	-
B-J	V2 21204-025-4		ISI-21204-025	ISI	-	-	-	-	-	-
B9.21	21204-025-4		2" PIPE TO ELBOW	AUG	-	-	-	-	-	-
1	1204			OWN	-	-	-	-	-	-
				PRE	-	-	-	-	-	-
B-J	V2 21204-025-5		ISI-21204-025	ISI	-	-	-	-	-	-
B9.21	21204-025-5		2" ELBOW TO PIPE	AUG	-	-	-	-	-	-
1	1204			OWN	-	-	-	-	-	-
				PRE	-	-	-	-	-	-
B-J	V2 21204-025-6		ISI-21204-025	ISI	-	-	-	-	-	-
B9.21	21204-025-6		2" PIPE TO PIPE	AUG	-	-	-	-	-	-
1	1204			OWN	-	-	-	-	-	-
				PRE	-	-	-	-	-	-
B-J	V2 21204-025-7		ISI-21204-025	ISI	-	-	-	-	-	-
B9.21	21204-025-7		2" PIPE TO ELBOW	AUG	-	-	-	-	-	-
1	1204			OWN	-	-	-	-	-	-
				PRE	-	-	-	-	-	-
B-J	V2 21204-025-8	ISI/PT/	ISI-21204-025	ISI	-	-	-	-	s	-
B9.21	21204-025-8		2" ELBOW TO PIPE	AUG	-	-	-	-	-	-
1	1204			OWN	-	-	-	-	-	-
				PRE	-	-	-	-	-	-
B-J	V2 21204-025-9		ISI-21204-025	ISI	-	-	-	-	-	-
B9.21	21204-025-9		2" PIPE TO ELBOW	AUG	-	-	-	-	-	-
1	1204			OWN	-	-	-	-	-	-
				PRE	-	-	-	-	-	-
B-J	V2 21204-033-2	ISI/PT/	ISI-21204-033	ISI	-	-	-	-	-	s
B9.21	21204-033-2		2" PIPE TO BRANCH CONNECTION	AUG	-	-	-	-	-	-
1	1204			OWN	-	-	-	-	-	-
				PRE	-	-	-	-	-	-
B-J	V2 21204-034-10	ISI/PT/	ISI-21204-034	ISI	-	-	-	-	-	s
B9.21	21204-034-10		2" PIPE TO BRANCH CONNECTION	AUG	-	-	-	-	-	-
1	1204			OWN	-	-	-	-	-	-
				PRE	-	-	-	-	-	-

**Southern Nuclear Operating Company
3rd Interval
VOGTLE-2 ISI PLAN, VERSION 3.0**

Category, Item No., Class	Summary No./CompID/System	Scope / Method / Procedure	Dwg/ISO No. Comp. Desc. Code Case		Period 1		Period 2		Period 3	
					2VR13	2VR14	2VR14A	2VR15	2VR16	2VR17
B-J B9.21 1	V2 21204-034-2 21204-034-2 1204		ISI-21204-034 2" PIPE TO TEE	ISI AUG OWN PRE	- - - -	- - - -	- - - -	- - - -	- - - -	- - - -
B-J B9.21 1	V2 21204-034-3 21204-034-3 1204		ISI-21204-034 2" TEE TO PIPE	ISI AUG OWN PRE	- - - -	- - - -	- - - -	- - - -	- - - -	- - - -
B-J B9.21 1	V2 21204-034-4 21204-034-4 1204		ISI-21204-034 2" PIPE TO ELBOW	ISI AUG OWN PRE	- - - -	- - - -	- - - -	- - - -	- - - -	- - - -
B-J B9.21 1	V2 21204-034-5 21204-034-5 1204		ISI-21204-034 2" ELBOW TO PIPE	ISI AUG OWN PRE	- - - -	- - - -	- - - -	- - - -	- - - -	- - - -
B-J B9.21 1	V2 21204-034-6 21204-034-6 1204		ISI-21204-034 2" PIPE TO ELBOW	ISI AUG OWN PRE	- - - -	- - - -	- - - -	- - - -	- - - -	- - - -
B-J B9.21 1	V2 21204-034-7 21204-034-7 1204		ISI-21204-034 2" ELBOW TO PIPE	ISI AUG OWN PRE	- - - -	- - - -	- - - -	- - - -	- - - -	- - - -
B-J B9.21 1	V2 21204-034-8 21204-034-8 1204		ISI-21204-034 2" PIPE TO ELBOW	ISI AUG OWN PRE	- - - -	- - - -	- - - -	- - - -	- - - -	- - - -
B-J B9.21 1	V2 21204-034-9 21204-034-9 1204		ISI-21204-034 2" ELBOW TO PIPE	ISI AUG OWN PRE	- - - -	- - - -	- - - -	- - - -	- - - -	- - - -
B-J B9.21 1	V2 21204-035-2 21204-035-2 1204	ISI/PT/	ISI-21204-035 2" PIPE TO BRANCH CONNECTION	ISI AUG OWN PRE	- - - -	- - - -	- - - -	s - - -	- - - -	- - - -
B-J B9.21 1	V2 21204-036-2 21204-036-2 1204		ISI-21204-036 2" PIPE TO TEE	ISI AUG OWN PRE	- - - -	- - - -	- - - -	- - - -	- - - -	- - - -

**Southern Nuclear Operating Company
3rd Interval
VOGTLE-2 ISI PLAN, VERSION 3.0**

Category, Item No., Class	Summary No./CompID/System	Scope / Method / Procedure	Dwg/ISO No. Comp. Desc. Code Case		Period 1		Period 2			Period 3	
					2VR13	2VR14	2VR14A	2VR15	2VR16	2VR17	2VR18
B-J B9.21 1	V2 21204-036-3 21204-036-3 1204		ISI-21204-036 2" TEE TO PIPE	ISI AUG OWN PRE	-	-	-	-	-	-	-
B-J B9.21 1	V2 21204-036-4 21204-036-4 1204	ISI/PT/	ISI-21204-036 2" PIPE TO ELBOW	ISI AUG OWN PRE	-	-	-	-	-	s	-
B-J B9.21 1	V2 21204-036-5 21204-036-5 1204	ISI/PT/	ISI-21204-036 2" ELBOW TO PIPE	ISI AUG OWN PRE	-	-	-	-	-	s	-
B-J B9.21 1	V2 21204-036-6 21204-036-6 1204	ISI/PT/	ISI-21204-036 2" PIPE TO BRANCH CONNECTION	ISI AUG OWN PRE	-	-	-	-	-	s	-
B-J B9.21 1	V2 21208-001-1 21208-001-1 1208		ISI-21208-001 3" VALVE TO PIPE	ISI AUG OWN PRE	-	-	-	-	-	-	-
B-J B9.21 1	V2 21208-001-2 21208-001-2 1208	ISI/PT/	ISI-21208-001 3" PIPE TO VALVE	ISI AUG OWN PRE	-	-	-	-	-	s	-
B-J B9.21 1	V2 21208-007-1 21208-007-1 1208	ISI/PT/	ISI-21208-007 3" VALVE TO PIPE	ISI AUG OWN PRE	-	-	-	s	-	-	-
B-J B9.21 1	V2 21208-007-2 21208-007-2 1208		ISI-21208-007 3" PIPE TO VALVE	ISI AUG OWN PRE	-	-	-	-	-	-	-
B-J B9.21 1	V2 21208-007-3 21208-007-3 1208		ISI-21208-007 3" VALVE TO PIPE	ISI AUG OWN PRE	-	-	-	-	-	-	-
B-J B9.21 1	V2 21208-007-4 21208-007-4 1208		ISI-21208-007 3" PIPE TO ELBOW	ISI AUG OWN PRE	-	-	-	-	-	-	-

**Southern Nuclear Operating Company
3rd Interval
VOGTLE-2 ISI PLAN, VERSION 3.0**

Category, Item No., Class	Summary No./ComplD/System	Scope / Method / Procedure	Dwg/ISO No. Comp. Desc. Code Case		Period 1		Period 2		Period 3					
					2VR13	2VR14	2VR14A	2VR15	2VR16	2VR17	2VR18			
B-J B9.21 1	V2 21208-007-5 21208-007-5 1208		ISI-21208-007 3" ELBOW TO PIPE	ISI AUG OWN PRE	-	-	-	-	-	-	-	-	-	-
B-J B9.21 1	V2 21208-007-6 21208-007-6 1208	ISI/PT/	ISI-21208-007 3" PIPE TO BRANCH CONNECTION	ISI AUG OWN PRE	-	-	-	-	s	-	-	-	-	-
B-J B9.21 1	V2 21208-009-1 21208-009-1 1208		ISI-21208-009 3" VALVE TO PIPE	ISI AUG OWN PRE	-	-	-	-	-	-	-	-	-	-
B-J B9.21 1	V2 21208-009-2 21208-009-2 1208		ISI-21208-009 3" PIPE TO VALVE	ISI AUG OWN PRE	-	-	-	-	-	-	-	-	-	-
B-J B9.21 1	V2 21208-009-3 21208-009-3 1208		ISI-21208-009 3" VALVE TO PIPE	ISI AUG OWN PRE	-	-	-	-	-	-	-	-	-	-
B-J B9.21 1	V2 21208-009-4 21208-009-4 1208		ISI-21208-009 3" PIPE TO ELBOW	ISI AUG OWN PRE	-	-	-	-	-	-	-	-	-	-
B-J B9.21 1	V2 21208-009-5 21208-009-5 1208	ISI/PT/	ISI-21208-009 3" ELBOW TO PIPE	ISI AUG OWN PRE	-	-	-	-	-	-	s	-	-	-
B-J B9.21 1	V2 21208-009-6 21208-009-6 1208		ISI-21208-009 3" PIPE TO BRANCH CONNECTION	ISI AUG OWN PRE	-	-	-	-	-	-	-	-	-	-
B-J B9.21 1	V2 21208-012-10 21208-012-10 1208		ISI-21208-012 2" PIPE TO ELBOW	ISI AUG OWN PRE	-	-	-	-	-	-	-	-	-	-
B-J B9.21 1	V2 21208-012-11 21208-012-11 1208		ISI-21208-012 2" ELBOW TO PIPE	ISI AUG OWN PRE	-	-	-	-	-	-	-	-	-	-

**Southern Nuclear Operating Company
3rd Interval
VOGTLE-2 ISI PLAN, VERSION 3.0**

Category, Item No., Class	Summary No./CompID/System	Scope / Method / Procedure	Dwg/ISO No. Comp. Desc. Code Case		Period 1		Period 2			Period 3	
					2VR13	2VR14	2VR14A	2VR15	2VR16	2VR17	2VR18
B-J B9.21 1	V2 21208-012-12 21208-012-12 1208	ISI/PT/	ISI-21208-012 2" PIPE TO BRANCH CONNECTION	ISI AUG OWN PRE	-	-	-	s	-	-	-
B-J B9.21 1	V2 21208-012-4 21208-012-4 1208	ISI/PT/	ISI-21208-012 2" PIPE TO ELBOW	ISI AUG OWN PRE	-	-	-	s	-	-	-
B-J B9.21 1	V2 21208-012-5 21208-012-5 1208	ISI/PT/	ISI-21208-012 2" ELBOW TO PIPE	ISI AUG OWN PRE	-	-	-	s	-	-	-
B-J B9.21 1	V2 21208-024-10 21208-024-10 1208		ISI-21208-024 1.5" TEE TO FLOW RESTRICTOR	ISI AUG OWN PRE	-	-	-	-	-	-	-
B-J B9.21 1	V2 21208-024-11 21208-024-11 1208		ISI-21208-024 1.5" TEE TO PIPE	ISI AUG OWN PRE	-	-	-	-	-	-	-
B-J B9.21 1	V2 21208-024-12 21208-024-12 1208		ISI-21208-024 1.5" PIPE TO FLANGE	ISI AUG OWN PRE	-	-	-	-	-	-	-
B-J B9.21 1	V2 21208-024-12 A 21208-024-12 A 1208		ISI-21208-024 1.5" FLANGE TO PIPE	ISI AUG OWN PRE	-	-	-	-	-	-	-
B-J B9.21 1	V2 21208-024-4 21208-024-4 1208		ISI-21208-024 1.5" PIPE TO TEE	ISI AUG OWN PRE	-	-	-	-	-	-	-
B-J B9.21 1	V2 21208-024-5 21208-024-5 1208		ISI-21208-024 1.5" TEE TO FLOW RESTRICTOR	ISI AUG OWN PRE	-	-	-	-	-	-	-
B-J B9.21 1	V2 21208-024-6 21208-024-6 1208		ISI-21208-024 1.5" TEE TO PIPE	ISI AUG OWN PRE	-	-	-	-	-	-	-

**Southern Nuclear Operating Company
3rd Interval
VOGTLE-2 ISI PLAN, VERSION 3.0**

Category, Item No., Class	Summary No./CompID/System	Scope / Method / Procedure	Dwg/ISO No. Comp. Desc. Code Case		Period 1		Period 2		Period 3	
					2VR13	2VR14	2VR14A	2VR15	2VR16	2VR17
B-J	V2 21208-024-7		ISI-21208-024	ISI	-	-	-	-	-	-
B9.21	21208-024-7		1.5" PIPE TO ELBOW	AUG	-	-	-	-	-	-
1	1208			OWN	-	-	-	-	-	-
				PRE	-	-	-	-	-	-
B-J	V2 21208-024-8		ISI-21208-024	ISI	-	-	-	-	-	-
B9.21	21208-024-8		1.5" ELBOW TO PIPE	AUG	-	-	-	-	-	-
1	1208			OWN	-	-	-	-	-	-
				PRE	-	-	-	-	-	-
B-J	V2 21208-024-9		ISI-21208-024	ISI	-	-	-	-	-	-
B9.21	21208-024-9		1.5" PIPE TO TEE	AUG	-	-	-	-	-	-
1	1208			OWN	-	-	-	-	-	-
				PRE	-	-	-	-	-	-
B-J	V2 21208-043-10	ISI/PT/	ISI-21208-043	ISI	-	-	-	-	s	-
B9.21	21208-043-10		1.5" ELBOW TO PIPE	AUG	-	-	-	-	-	-
1	1208			OWN	-	-	-	-	-	-
				PRE	-	-	-	-	-	-
B-J	V2 21208-043-11	ISI/PT/	ISI-21208-043	ISI	-	-	-	-	s	-
B9.21	21208-043-11		1.5" PIPE TO ELBOW	AUG	-	-	-	-	-	-
1	1208			OWN	-	-	-	-	-	-
				PRE	-	-	-	-	-	-
B-J	V2 21208-043-12		ISI-21208-043	ISI	-	-	-	-	-	-
B9.21	21208-043-12		1.5" ELBOW TO PIPE	AUG	-	-	-	-	-	-
1	1208			OWN	-	-	-	-	-	-
				PRE	-	-	-	-	-	-
B-J	V2 21208-043-13		ISI-21208-043	ISI	-	-	-	-	-	-
B9.21	21208-043-13		1.5" PIPE TO TEE	AUG	-	-	-	-	-	-
1	1208			OWN	-	-	-	-	-	-
				PRE	-	-	-	-	-	-
B-J	V2 21208-043-14		ISI-21208-043	ISI	-	-	-	-	-	-
B9.21	21208-043-14		1.5" TEE TO FLOW RESTRICTOR	AUG	-	-	-	-	-	-
1	1208			OWN	-	-	-	-	-	-
				PRE	-	-	-	-	-	-
B-J	V2 21208-043-15	ISI/PT/	ISI-21208-043	ISI	-	-	-	-	s	-
B9.21	21208-043-15		1.5" TEE TO PIPE	AUG	-	-	-	-	-	-
1	1208			OWN	-	-	-	-	-	-
				PRE	-	-	-	-	-	-
B-J	V2 21208-043-16	ISI/PT/	ISI-21208-043	ISI	-	-	-	-	s	-
B9.21	21208-043-16		1.5" PIPE TO FLANGE	AUG	-	-	-	-	-	-
1	1208			OWN	-	-	-	-	-	-
				PRE	-	-	-	-	-	-

Southern Nuclear Operating Company
3rd Interval
VOGTLE-2 ISI PLAN, VERSION 3.0

Category, Item No., Class	Summary No./CompID/System	Scope / Method / Procedure	Dwg/ISO No. Comp. Desc. Code Case		Period 1		Period 2		Period 3	
					2VR13	2VR14	2VR14A	2VR15	2VR16	2VR17
B-J B9.21 1	V2 21208-043-16 A 21208-043-16 A 1208	ISI/PT/	ISI-21208-043 1.5" FLANGE TO PIPE	ISI AUG OWN PRE	- - - -	- - - -	- - - -	- - - -	- - - -	s - - -
B-J B9.21 1	V2 21208-043-4 21208-043-4 1208	ISI/PT/	ISI-21208-043 1.5" PIPE TO TEE	ISI AUG OWN PRE	- - - -	- - - -	- - - -	s - - -	- - - -	- - - -
B-J B9.21 1	V2 21208-043-5 21208-043-5 1208	ISI/PT/	ISI-21208-043 1.5" TEE TO FLOW RESTRICTOR	ISI AUG OWN PRE	- - - -	- - - -	- - - -	s - - -	- - - -	- - - -
B-J B9.21 1	V2 21208-043-6 21208-043-6 1208	ISI/PT/	ISI-21208-043 1.5" TEE TO PIPE	ISI AUG OWN PRE	- - - -	- - - -	- - - -	s - - -	- - - -	- - - -
B-J B9.21 1	V2 21208-043-7 21208-043-7 1208	ISI/PT/	ISI-21208-043 1.5" PIPE TO ELBOW	ISI AUG OWN PRE	- - - -	- - - -	- - - -	s - - -	- - - -	- - - -
B-J B9.21 1	V2 21208-043-8 21208-043-8 1208	ISI/PT/	ISI-21208-043 1.5" ELBOW TO PIPE	ISI AUG OWN PRE	- - - -	- - - -	- - - -	s - - -	- - - -	- - - -
B-J B9.21 1	V2 21208-043-9 21208-043-9 1208		ISI-21208-043 1.5" PIPE TO ELBOW	ISI AUG OWN PRE	- - - -	- - - -	- - - -	- - - -	- - - -	- - - -
B-J B9.21 1	V2 21208-045-10 21208-045-10 1208		ISI-21208-045 1.5" TEE TO PIPE	ISI AUG OWN PRE	- - - -	- - - -	- - - -	- - - -	- - - -	- - - -
B-J B9.21 1	V2 21208-045-11 21208-045-11 1208	ISI/PT/	ISI-21208-045 1.5" PIPE TO ELBOW	ISI AUG OWN PRE	- - - -	- - - -	- - - -	- - - -	s - - -	- - - -
B-J B9.21 1	V2 21208-045-12 21208-045-12 1208	ISI/PT/	ISI-21208-045 1.5" ELBOW TO PIPE	ISI AUG OWN PRE	- - - -	- - - -	- - - -	- - - -	s - - -	- - - -

Southern Nuclear Operating Company
3rd Interval
VOGTLE-2 ISI PLAN, VERSION 3.0

Category, Item No., Class	Summary No./ComplID/System	Scope / Method / Procedure	Dwg/ISO No. Comp. Desc. Code Case		Period 1		Period 2		Period 3	
					2VR13	2VR14	2VR14A	2VR15	2VR16	2VR17
B-J	V2 21208-045-13		ISI-21208-045	ISI	-	-	-	-	-	-
B9.21	21208-045-13		1.5" PIPE TO ELBOW	AUG	-	-	-	-	-	-
1	1208			OWN	-	-	-	-	-	-
				PRE	-	-	-	-	-	-
B-J	V2 21208-045-14		ISI-21208-045	ISI	-	-	-	-	-	-
B9.21	21208-045-14		1.5" ELBOW TO PIPE	AUG	-	-	-	-	-	-
1	1208			OWN	-	-	-	-	-	-
				PRE	-	-	-	-	-	-
B-J	V2 21208-045-15		ISI-21208-045	ISI	-	-	-	-	-	-
B9.21	21208-045-15		1.5" PIPE TO ELBOW	AUG	-	-	-	-	-	-
1	1208			OWN	-	-	-	-	-	-
				PRE	-	-	-	-	-	-
B-J	V2 21208-045-16		ISI-21208-045	ISI	-	-	-	-	-	-
B9.21	21208-045-16		1.5" ELBOW TO PIPE	AUG	-	-	-	-	-	-
1	1208			OWN	-	-	-	-	-	-
				PRE	-	-	-	-	-	-
B-J	V2 21208-045-17		ISI-21208-045	ISI	-	-	-	-	-	-
B9.21	21208-045-17		1.5" PIPE TO TEE	AUG	-	-	-	-	-	-
1	1208			OWN	-	-	-	-	-	-
				PRE	-	-	-	-	-	-
B-J	V2 21208-045-18		ISI-21208-045	ISI	-	-	-	-	-	-
B9.21	21208-045-18		1.5" TEE TO FLOW RESTRICTOR	AUG	-	-	-	-	-	-
1	1208			OWN	-	-	-	-	-	-
				PRE	-	-	-	-	-	-
B-J	V2 21208-045-19		ISI-21208-045	ISI	-	-	-	-	-	-
B9.21	21208-045-19		1.5" TEE TO PIPE	AUG	-	-	-	-	-	-
1	1208			OWN	-	-	-	-	-	-
				PRE	-	-	-	-	-	-
B-J	V2 21208-045-20		ISI-21208-045	ISI	-	-	-	-	-	-
B9.21	21208-045-20		1.5" PIPE TO FLANGE	AUG	-	-	-	-	-	-
1	1208			OWN	-	-	-	-	-	-
				PRE	-	-	-	-	-	-
B-J	V2 21208-045-20 A		ISI-21208-045	ISI	-	-	-	-	-	-
B9.21	21208-045-20 A		1.5" FLANGE TO PIPE	AUG	-	-	-	-	-	-
1	1208			OWN	-	-	-	-	-	-
				PRE	-	-	-	-	-	-
B-J	V2 21208-045-4		ISI-21208-045	ISI	-	-	-	-	-	-
B9.21	21208-045-4		1.5" PIPE TO TEE	AUG	-	-	-	-	-	-
1	1208			OWN	-	-	-	-	-	-
				PRE	-	-	-	-	-	-

Southern Nuclear Operating Company
3rd Interval
VOGTLE-2 ISI PLAN, VERSION 3.0

Category, Item No., Class	Summary No./CompID/System	Scope / Method / Procedure	Dwg/ISO No. Comp. Desc. Code Case		Period 1		Period 2		Period 3	
					2VR13	2VR14	2VR14A	2VR15	2VR16	2VR17
B-J	V2 21208-045-5		ISI-21208-045	ISI	-	-	-	-	-	-
B9.21	21208-045-5		1.5" TEE TO PIPE	AUG	-	-	-	-	-	-
1	1208			OWN	-	-	-	-	-	-
				PRE	-	-	-	-	-	-
B-J	V2 21208-045-6		ISI-21208-045	ISI	-	-	-	-	-	-
B9.21	21208-045-6		1.5" PIPE TO SWAGE	AUG	-	-	-	-	-	-
1	1208			OWN	-	-	-	-	-	-
				PRE	-	-	-	-	-	-
B-J	V2 21208-045-7		ISI-21208-045	ISI	-	-	-	-	-	-
B9.21	21208-045-7		1.5" TEE TO PIPE	AUG	-	-	-	-	-	-
1	1208			OWN	-	-	-	-	-	-
				PRE	-	-	-	-	-	-
B-J	V2 21208-045-8		ISI-21208-045	ISI	-	-	-	-	-	-
B9.21	21208-045-8		1.5" PIPE TO TEE	AUG	-	-	-	-	-	-
1	1208			OWN	-	-	-	-	-	-
				PRE	-	-	-	-	-	-
B-J	V2 21208-045-9		ISI-21208-045	ISI	-	-	-	-	-	-
B9.21	21208-045-9		1.5" TEE TO FLOW RESTRICTOR	AUG	-	-	-	-	-	-
1	1208			OWN	-	-	-	-	-	-
				PRE	-	-	-	-	-	-
B-J	V2 21208-047-10		ISI-21208-047	ISI	-	-	-	-	-	-
B9.21	21208-047-10		1.5" ELBOW TO PIPE	AUG	-	-	-	-	-	-
1	1208			OWN	-	-	-	-	-	-
				PRE	-	-	-	-	-	-
B-J	V2 21208-047-11		ISI-21208-047	ISI	-	-	-	-	-	-
B9.21	21208-047-11		1.5" PIPE TO ELBOW	AUG	-	-	-	-	-	-
1	1208			OWN	-	-	-	-	-	-
				PRE	-	-	-	-	-	-
B-J	V2 21208-047-12		ISI-21208-047	ISI	-	-	-	-	-	-
B9.21	21208-047-12		1.5" ELBOW TO PIPE	AUG	-	-	-	-	-	-
1	1208			OWN	-	-	-	-	-	-
				PRE	-	-	-	-	-	-
B-J	V2 21208-047-13		ISI-21208-047	ISI	-	-	-	-	-	-
B9.21	21208-047-13		1.5" PIPE TO ELBOW	AUG	-	-	-	-	-	-
1	1208			OWN	-	-	-	-	-	-
				PRE	-	-	-	-	-	-
B-J	V2 21208-047-14		ISI-21208-047	ISI	-	-	-	-	-	-
B9.21	21208-047-14		1.5" ELBOW TO PIPE	AUG	-	-	-	-	-	-
1	1208			OWN	-	-	-	-	-	-
				PRE	-	-	-	-	-	-

Southern Nuclear Operating Company
3rd Interval
VOGTLE-2 ISI PLAN, VERSION 3.0

Category, Item No., Class	Summary No./CompID/System	Scope / Method / Procedure	Dwg/ISO No. Comp. Desc. Code Case		Period 1		Period 2		Period 3	
					2VR13	2VR14	2VR14A	2VR15	2VR16	2VR17
B-J B9.21 1	V2 21208-047-15 21208-047-15 1208		ISI-21208-047 1.5" PIPE TO TEE	ISI AUG OWN PRE	- - - -	- - - -	- - - -	- - - -	- - - -	- - - -
B-J B9.21 1	V2 21208-047-16 21208-047-16 1208		ISI-21208-047 1.5" TEE TO FLOW RESTRICTOR	ISI AUG OWN PRE	- - - -	- - - -	- - - -	- - - -	- - - -	- - - -
B-J B9.21 1	V2 21208-047-17 21208-047-17 1208		ISI-21208-047 1.5" TEE TO PIPE	ISI AUG OWN PRE	- - - -	- - - -	- - - -	- - - -	- - - -	- - - -
B-J B9.21 1	V2 21208-047-18 21208-047-18 1208		ISI-21208-047 1.5" PIPE TO FLANGE	ISI AUG OWN PRE	- - - -	- - - -	- - - -	- - - -	- - - -	- - - -
B-J B9.21 1	V2 21208-047-18 A 21208-047-18 A 1208		ISI-21208-047 1.5" FLANGE TO PIPE	ISI AUG OWN PRE	- - - -	- - - -	- - - -	- - - -	- - - -	- - - -
B-J B9.21 1	V2 21208-047-4 21208-047-4 1208		ISI-21208-047 1.5" PIPE TO ELBOW	ISI AUG OWN PRE	- - - -	- - - -	- - - -	- - - -	- - - -	- - - -
B-J B9.21 1	V2 21208-047-5 21208-047-5 1208		ISI-21208-047 1.5" ELBOW TO PIPE	ISI AUG OWN PRE	- - - -	- - - -	- - - -	- - - -	- - - -	- - - -
B-J B9.21 1	V2 21208-047-6 21208-047-6 1208	ISI/PT/	ISI-21208-047 1.5" PIPE TO TEE	ISI AUG OWN PRE	- - - -	- - - -	- - - -	s - - -	- - - -	- - - -
B-J B9.21 1	V2 21208-047-7 21208-047-7 1208	ISI/PT/	ISI-21208-047 1.5" TEE TO FLOW RESTRICTOR	ISI AUG OWN PRE	- - - -	- - - -	- - - -	s - - -	- - - -	- - - -
B-J B9.21 1	V2 21208-047-8 21208-047-8 1208		ISI-21208-047 1.5" TEE TO PIPE	ISI AUG OWN PRE	- - - -	- - - -	- - - -	- - - -	- - - -	- - - -

Southern Nuclear Operating Company
3rd Interval
VOGTLE-2 ISI PLAN, VERSION 3.0

Category, Item No., Class	Summary No./CompID/System	Scope / Method / Procedure	Dwg/ISO No. Comp. Desc. Code Case		Period 1		Period 2		Period 3											
					2VR13	2VR14	2VR14A	2VR15	2VR16	2VR17	2VR18									
B-J B9.21 1	V2 21208-047-9 21208-047-9 1208		ISI-21208-047 1.5" PIPE TO ELBOW	ISI AUG OWN PRE	-	-	-	-	-	-	-	-	-	-	-	-	-	-	-	-
B-J B9.22 1	V2 21204-076-1 21204-076-1 1204	ISI/PT/	ISI-21204-076 3" VALVE TO PIPE	ISI AUG OWN PRE	-	-	-	-	-	-	-	-	-	-	-	-	-	-	-	s
B-J B9.22 1	V2 21204-076-10 21204-076-10 1204	ISI/PT/	ISI-21204-076 3" ELBOW TO PIPE	ISI AUG OWN PRE	-	-	-	-	-	-	-	-	-	-	-	-	-	-	-	s
B-J B9.22 1	V2 21204-076-11 21204-076-11 1204		ISI-21204-076 3" PIPE TO PIPE	ISI AUG OWN PRE	-	-	-	-	-	-	-	-	-	-	-	-	-	-	-	-
B-J B9.22 1	V2 21204-076-13 21204-076-13 1204		ISI-21204-076 3" PIPE TO PIPE	ISI AUG OWN PRE	-	-	-	-	-	-	-	-	-	-	-	-	-	-	-	-
B-J B9.22 1	V2 21204-076-14 21204-076-14 1204		ISI-21204-076 3" PIPE TO PIPE	ISI AUG OWN PRE	-	-	-	-	-	-	-	-	-	-	-	-	-	-	-	-
B-J B9.22 1	V2 21204-076-16 21204-076-16 1204		ISI-21204-076 3" PIPE TO PIPE	ISI AUG OWN PRE	-	-	-	-	-	-	-	-	-	-	-	-	-	-	-	-
B-J B9.22 1	V2 21204-076-17 21204-076-17 1204	ISI/PT/	ISI-21204-076 3" PIPE TO ELBOW	ISI AUG OWN PRE	-	-	-	-	-	-	-	-	-	-	-	-	-	-	-	s
B-J B9.22 1	V2 21204-076-18 21204-076-18 1204		ISI-21204-076 3" ELBOW TO PIPE	ISI AUG OWN PRE	-	-	-	-	-	-	-	-	-	-	-	-	-	-	-	-
B-J B9.22 1	V2 21204-076-19 21204-076-19 1204		ISI-21204-076 3" PIPE TO ELBOW	ISI AUG OWN PRE	-	-	-	-	-	-	-	-	-	-	-	-	-	-	-	-

Southern Nuclear Operating Company
3rd Interval
VOGTLE-2 ISI PLAN, VERSION 3.0

Category, Item No., Class	Summary No./CompID/System	Scope / Method / Procedure	Dwg/ISO No. Comp. Desc. Code Case		Period 1		Period 2		Period 3	
					2VR13	2VR14	2VR14A	2VR15	2VR16	2VR17
B-J B9.22 1	V2 21204-076-2 21204-076-2 1204	ISI/UT/NMP-ES-024-501	ISI-21204-076 3" PIPE TO ELBOW	ISI AUG OWN PRE	- - - -	- - - -	- - - -	- - - -	- - - -	- - - -
B-J B9.22 1	V2 21204-076-20 21204-076-20 1204		ISI-21204-076 3" ELBOW TO PIPE	ISI AUG OWN PRE	- - - -	- - - -	- - - -	- - - -	- - - -	- - - -
B-J B9.22 1	V2 21204-076-21 21204-076-21 1204		ISI-21204-076 3" PIPE TO PIPE	ISI AUG OWN PRE	- - - -	- - - -	- - - -	- - - -	- - - -	- - - -
B-J B9.22 1	V2 21204-076-22 21204-076-22 1204		ISI-21204-076 3" PIPE TO PIPE	ISI AUG OWN PRE	- - - -	- - - -	- - - -	- - - -	- - - -	- - - -
B-J B9.22 1	V2 21204-076-23 21204-076-23 1204		ISI-21204-076 3" PIPE TO PIPE	ISI AUG OWN PRE	- - - -	- - - -	- - - -	- - - -	- - - -	- - - -
B-J B9.22 1	V2 21204-076-24 21204-076-24 1204		ISI-21204-076 3" PIPE TO PIPE	ISI AUG OWN PRE	- - - -	- - - -	- - - -	- - - -	- - - -	- - - -
B-J B9.22 1	V2 21204-076-25 21204-076-25 1204		ISI-21204-076 3" PIPE TO PIPE	ISI AUG OWN PRE	- - - -	- - - -	- - - -	- - - -	- - - -	- - - -
B-J B9.22 1	V2 21204-076-26 21204-076-26 1204		ISI-21204-076 3" PIPE TO PIPE	ISI AUG OWN PRE	- - - -	- - - -	- - - -	- - - -	- - - -	- - - -
B-J B9.22 1	V2 21204-076-27 21204-076-27 1204		ISI-21204-076 3" PIPE TO PIPE	ISI AUG OWN PRE	- - - -	- - - -	- - - -	- - - -	- - - -	- - - -
B-J B9.22 1	V2 21204-076-28 21204-076-28 1204		ISI-21204-076 3" PIPE TO PIPE	ISI AUG OWN PRE	- - - -	- - - -	- - - -	- - - -	- - - -	- - - -

**Southern Nuclear Operating Company
3rd Interval
VOGTLE-2 ISI PLAN, VERSION 3.0**

Category, Item No., Class	Summary No./CompID/System	Scope / Method / Procedure	Dwg/ISO No. Comp. Desc. Code Case		Period 1		Period 2			Period 3	
					2VR13	2VR14	2VR14A	2VR15	2VR16	2VR17	2VR18
B-J B9.22 1	V2 21204-076-29 21204-076-29 1204		ISI-21204-076 3" PIPE TO PIPE	ISI AUG OWN PRE	- - - -	- - - -	- - - -	- - - -	- - - -	- - - -	- - - -
B-J B9.22 1	V2 21204-076-3 21204-076-3 1204		ISI-21204-076 3" ELBOW TO PIPE	ISI AUG OWN PRE	- - - -	- - - -	- - - -	- - - -	- - - -	- - - -	- - - -
B-J B9.22 1	V2 21204-076-30 21204-076-30 1204		ISI-21204-076 3" PIPE TO ELBOW	ISI AUG OWN PRE	- - - -	- - - -	- - - -	- - - -	- - - -	- - - -	- - - -
B-J B9.22 1	V2 21204-076-31 21204-076-31 1204		ISI-21204-076 3" ELBOW TO PIPE	ISI AUG OWN PRE	- - - -	- - - -	- - - -	- - - -	- - - -	- - - -	- - - -
B-J B9.22 1	V2 21204-076-32 A 21204-076-32 A 1204		ISI-21204-076 3" PIPE TO TEE	ISI AUG OWN PRE	- - - -	- - - -	- - - -	- - - -	- - - -	- - - -	- - - -
B-J B9.22 1	V2 21204-076-32 B 21204-076-32 B 1204		ISI-21204-076 3" TEE TO FLANGE	ISI AUG OWN PRE	- - - -	- - - -	- - - -	- - - -	- - - -	- - - -	- - - -
B-J B9.22 1	V2 21204-076-32 C 21204-076-32 C 1204		ISI-21204-076 3" TEE TO PIPE	ISI AUG OWN PRE	- - - -	- - - -	- - - -	- - - -	- - - -	- - - -	- - - -
B-J B9.22 1	V2 21204-076-33 21204-076-33 1204		ISI-21204-076 3" PIPE TO REDUCER	ISI AUG OWN PRE	- - - -	- - - -	- - - -	- - - -	- - - -	- - - -	- - - -
B-J B9.22 1	V2 21204-076-34 21204-076-34 1204	ISI/PT/	ISI-21204-076 1.5" BRANCH CONNECTION TO PIPE	ISI AUG OWN PRE	- - - -	- - - -	- - - -	- - - -	- - - -	s - - -	- - - -
B-J B9.22 1	V2 21204-076-35 21204-076-35 1204	ISI/PT/	ISI-21204-076 1.5" PIPE TO ELBOW (AI 87-0131)	ISI AUG OWN PRE	- - - -	- - - -	- - - -	- - - -	s - - -	- - - -	- - - -

**Southern Nuclear Operating Company
3rd Interval
VOGTLE-2 ISI PLAN, VERSION 3.0**

Category, Item No., Class	Summary No./Compid/System	Scope / Method / Procedure	Dwg/ISO No. Comp. Desc. Code Case	Period 1		Period 2			Period 3	
				2VR13	2VR14	2VR14A	2VR15	2VR16	2VR17	2VR18
B-J B9.22 1	V2 21204-076-36 21204-076-36 1204	ISI/UT/NMP-ES-024-501	ISI-21204-076 1.5" ELBOW TO PIPE (AI 87-0131)	ISI AUG OWN PRE	c -	-	-	-	-	-
B-J B9.22 1	V2 21204-076-37 21204-076-37 1204		ISI-21204-076 1.5" PIPE TO TEE	ISI AUG OWN PRE	-	-	-	-	-	-
B-J B9.22 1	V2 21204-076-38 21204-076-38 1204		ISI-21204-076 1.5" TEE TO PIPE	ISI AUG OWN PRE	-	-	-	-	-	-
B-J B9.22 1	V2 21204-076-39 21204-076-39 1204		ISI-21204-076 1.5" PIPE TO ELBOW	ISI AUG OWN PRE	-	-	-	-	-	-
B-J B9.22 1	V2 21204-076-4 21204-076-4 1204		ISI-21204-076 3" PIPE TO ELBOW	ISI AUG OWN PRE	-	-	-	-	-	-
B-J B9.22 1	V2 21204-076-40 21204-076-40 1204		ISI-21204-076 1.5" ELBOW TO PIPE	ISI AUG OWN PRE	-	-	-	-	-	-
B-J B9.22 1	V2 21204-076-41 21204-076-41 1204		ISI-21204-076 1.5" PIPE TO ELBOW	ISI AUG OWN PRE	-	-	-	-	-	-
B-J B9.22 1	V2 21204-076-42 21204-076-42 1204		ISI-21204-076 1.5" ELBOW TO PIPE	ISI AUG OWN PRE	-	-	-	-	-	-
B-J B9.22 1	V2 21204-076-43 21204-076-43 1204		ISI-21204-076 1.5" PIPE TO FLANGE (AI 87-0131)	ISI AUG OWN PRE	-	-	-	-	-	-
B-J B9.22 1	V2 21204-076-44 21204-076-44 1204		ISI-21204-076 1.5" FLANGE TO PIPE (AI 87-0131)	ISI AUG OWN PRE	-	-	-	-	-	-

**Southern Nuclear Operating Company
3rd Interval
VOGTLE-2 ISI PLAN, VERSION 3.0**

Category, Item No., Class	Summary No./ComplID/System	Scope / Method / Procedure	Dwg/ISO No. Comp. Desc. Code Case		Period 1		Period 2		Period 3	
					2VR13	2VR14	2VR14A	2VR15	2VR16	2VR17
B-J B9.22 1	V2 21204-076-5 21204-076-5 1204		ISI-21204-076 3" ELBOW TO PIPE	ISI AUG OWN PRE	- - - -	- - - -	- - - -	- - - -	- - - -	- - - -
B-J B9.22 1	V2 21204-076-6 21204-076-6 1204		ISI-21204-076 3" PIPE TO PIPE	ISI AUG OWN PRE	- - - -	- - - -	- - - -	- - - -	- - - -	- - - -
B-J B9.22 1	V2 21204-076-7 21204-076-7 1204		ISI-21204-076 3" PIPE TO ELBOW	ISI AUG OWN PRE	- - - -	- - - -	- - - -	- - - -	- - - -	- - - -
B-J B9.22 1	V2 21204-076-8 21204-076-8 1204		ISI-21204-076 3" ELBOW TO PIPE	ISI AUG OWN PRE	- - - -	- - - -	- - - -	- - - -	- - - -	- - - -
B-J B9.22 1	V2 21204-076-9 21204-076-9 1204		ISI-21204-076 3" PIPE TO ELBOW	ISI AUG OWN PRE	- - - -	- - - -	- - - -	- - - -	- - - -	- - - -
B-J B9.22 1	V2 21204-077-1 21204-077-1 1204	ISI/PT/	ISI-21204-077 1.5" BRANCH CONNECTION TO PIPE	ISI AUG OWN PRE	- - - -	- - - -	- - - -	s - - -	- - - -	- - - -
B-J B9.22 1	V2 21204-077-10 21204-077-10 1204	ISI/PT/	ISI-21204-077 1.5" PIPE TO FLANGE	ISI AUG OWN PRE	- - - -	- - - -	- - - -	s - - -	- - - -	- - - -
B-J B9.22 1	V2 21204-077-11 21204-077-11 1204	ISI/PT/	ISI-21204-077 1.5" FLANGE TO PIPE	ISI AUG OWN PRE	- - - -	- - - -	- - - -	s - - -	- - - -	- - - -
B-J B9.22 1	V2 21204-077-2 21204-077-2 1204		ISI-21204-077 1.5" PIPE TO ELBOW	ISI AUG OWN PRE	- - - -	- - - -	- - - -	- - - -	- - - -	- - - -
B-J B9.22 1	V2 21204-077-3 21204-077-3 1204		ISI-21204-077 1.5" ELBOW TO PIPE	ISI AUG OWN PRE	- - - -	- - - -	- - - -	- - - -	- - - -	- - - -

Southern Nuclear Operating Company
3rd Interval
VOGTLE-2 ISI PLAN, VERSION 3.0

Category, Item No., Class	Summary No./CompID/System	Scope / Method / Procedure	Dwg/ISO No. Comp. Desc. Code Case		Period 1		Period 2		Period 3	
					2VR13	2VR14	2VR14A	2VR15	2VR16	2VR17
B-J B9.22 1	V2 21204-077-4 21204-077-4 1204		ISI-21204-077 1.5" PIPE TO TEE	ISI AUG OWN PRE	- - - -	- - - -	- - - -	- - - -	- - - -	- - - -
B-J B9.22 1	V2 21204-077-5 21204-077-5 1204	ISI/PT/	ISI-21204-077 1.5" TEE TO PIPE	ISI AUG OWN PRE	- - - -	- - - -	- - - -	s - - -	- - - -	- - - -
B-J B9.22 1	V2 21204-077-6 21204-077-6 1204	ISI/PT/	ISI-21204-077 1.5" PIPE TO ELBOW	ISI AUG OWN PRE	- - - -	- - - -	- - - -	s - - -	- - - -	- - - -
B-J B9.22 1	V2 21204-077-7 21204-077-7 1204		ISI-21204-077 1.5" ELBOW TO PIPE	ISI AUG OWN PRE	- - - -	- - - -	- - - -	- - - -	- - - -	- - - -
B-J B9.22 1	V2 21204-077-8 21204-077-8 1204		ISI-21204-077 1.5" PIPE TO ELBOW	ISI AUG OWN PRE	- - - -	- - - -	- - - -	- - - -	- - - -	- - - -
B-J B9.22 1	V2 21204-077-9 21204-077-9 1204	ISI/UT/NMP-ES-024-501	ISI-21204-077 1.5" ELBOW TO PIPE	ISI AUG OWN PRE	c - - -	- - - -	- - - -	- - - -	- - - -	- - - -
B-J B9.22 1	V2 21204-077-9 A 21204-077-9 A 1204		ISI-21204-077 1.5" PIPE TO ELBOW	ISI AUG OWN PRE	- - - -	- - - -	- - - -	- - - -	- - - -	- - - -
B-J B9.22 1	V2 21204-077-9 B 21204-077-9 B 1204	ISI/PT/	ISI-21204-077 1.5" ELBOW TO PIPE	ISI AUG OWN PRE	- - - -	- - - -	- - - -	s - - -	- - - -	- - - -
B-J B9.22 1	V2 21204-078-1 21204-078-1 1204	ISI/PT/	ISI-21204-078 1.5" BRANCH CONNECTION TO PIPE	ISI AUG OWN PRE	- - - -	- - - -	- - - -	s - - -	- - - -	- - - -
B-J B9.22 1	V2 21204-078-10 21204-078-10 1204	ISI/UT/NMP-ES-024-501	ISI-21204-078 1.5" PIPE TO ELBOW	ISI AUG OWN PRE	c - - -	- - - -	- - - -	- - - -	- - - -	- - - -

**Southern Nuclear Operating Company
3rd Interval
VOGTLE-2 ISI PLAN, VERSION 3.0**

Category, Item No., Class	Summary No./CompID/System	Scope / Method / Procedure	Dwg/ISO No. Comp. Desc. Code Case		Period 1		Period 2			Period 3	
					2VR13	2VR14	2VR14A	2VR15	2VR16	2VR17	2VR18
B-J B9.22 1	V2 21204-078-11 21204-078-11 1204		ISI-21204-078 1.5" ELBOW TO PIPE	ISI AUG OWN PRE	-	-	-	-	-	-	-
B-J B9.22 1	V2 21204-078-2 21204-078-2 1204		ISI-21204-078 1.5" PIPE TO ELBOW	ISI AUG OWN PRE	-	-	-	-	-	-	-
B-J B9.22 1	V2 21204-078-3 21204-078-3 1204		ISI-21204-078 1.5" ELBOW TO PIPE	ISI AUG OWN PRE	-	-	-	-	-	-	-
B-J B9.22 1	V2 21204-078-4 21204-078-4 1204		ISI-21204-078 1.5" PIPE TO ELBOW	ISI AUG OWN PRE	-	-	-	-	-	-	-
B-J B9.22 1	V2 21204-078-5 21204-078-5 1204		ISI-21204-078 1.5" ELBOW TO PIPE	ISI AUG OWN PRE	-	-	-	-	-	-	-
B-J B9.22 1	V2 21204-078-6 21204-078-6 1204		ISI-21204-078 1.5" PIPE TO ELBOW	ISI AUG OWN PRE	-	-	-	-	-	-	-
B-J B9.22 1	V2 21204-078-7 21204-078-7 1204	ISI/PT/	ISI-21204-078 1.5" ELBOW TO PIPE	ISI AUG OWN PRE	-	-	-	-	-	s	-
B-J B9.22 1	V2 21204-078-8 21204-078-8 1204	ISI/PT/	ISI-21204-078 1.5" PIPE TO FLANGE	ISI AUG OWN PRE	-	-	-	-	-	s	-
B-J B9.22 1	V2 21204-078-9 21204-078-9 1204		ISI-21204-078 1.5" FLANGE TO PIPE	ISI AUG OWN PRE	-	-	-	-	-	-	-
B-J B9.22 1	V2 21204-079-1 21204-079-1 1204		ISI-21204-079 1.5" REDUCER TO PIPE	ISI AUG OWN PRE	-	-	-	-	-	-	-

Southern Nuclear Operating Company
3rd Interval
VOGTLE-2 ISI PLAN, VERSION 3.0

Category, Item No., Class	Summary No./ComplD/System	Scope / Method / Procedure	Dwg/ISO No. Comp. Desc. Code Case		Period 1		Period 2			Period 3	
					2VR13	2VR14	2VR14A	2VR15	2VR16	2VR17	2VR18
B-J B9.22 1	V2 21204-079-10 21204-079-10 1204	ISI/UT/NMP-ES-024-501	ISI-21204-079 1.5" ELBOW TO PIPE	ISI AUG OWN PRE	c	-	-	-	-	-	-
B-J B9.22 1	V2 21204-079-11 21204-079-11 1204		ISI-21204-079 1.5" PIPE TO FLANGE	ISI AUG OWN PRE	-	-	-	-	-	-	-
B-J B9.22 1	V2 21204-079-12 21204-079-12 1204		ISI-21204-079 1.5" FLANGE TO PIPE	ISI AUG OWN PRE	-	-	-	-	-	-	-
B-J B9.22 1	V2 21204-079-2 21204-079-2 1204		ISI-21204-079 1.5" PIPE TO ELBOW	ISI AUG OWN PRE	-	-	-	-	-	-	-
B-J B9.22 1	V2 21204-079-3 21204-079-3 1204	ISI/PT/	ISI-21204-079 1.5" ELBOW TO PIPE	ISI AUG OWN PRE	-	-	-	s	-	-	-
B-J B9.22 1	V2 21204-079-4 21204-079-4 1204		ISI-21204-079 1.5" PIPE TO PIPE	ISI AUG OWN PRE	-	-	-	-	-	-	-
B-J B9.22 1	V2 21204-079-5 21204-079-5 1204	ISI/PT/	ISI-21204-079 1.5" PIPE TO ELBOW	ISI AUG OWN PRE	-	-	-	-	-	s	-
B-J B9.22 1	V2 21204-079-6 21204-079-6 1204		ISI-21204-079 1.5" ELBOW TO PIPE	ISI AUG OWN PRE	-	-	-	-	-	-	-
B-J B9.22 1	V2 21204-079-7 21204-079-7 1204		ISI-21204-079 1.5" PIPE TO ELBOW	ISI AUG OWN PRE	-	-	-	-	-	-	-
B-J B9.22 1	V2 21204-079-8 21204-079-8 1204		ISI-21204-079 1.5" ELBOW TO PIPE	ISI AUG OWN PRE	-	-	-	-	-	-	-

**Southern Nuclear Operating Company
3rd Interval
VOGTLE-2 ISI PLAN, VERSION 3.0**

Category, Item No., Class	Summary No./CompID/System	Scope / Method / Procedure	Dwg/ISO No. Comp. Desc. Code Case		Period 1		Period 2			Period 3	
					2VR13	2VR14	2VR14A	2VR15	2VR16	2VR17	2VR18
B-J B9.22 1	V2 21204-079-9 21204-079-9 1204		ISI-21204-079 1.5" PIPE TO ELBOW	ISI AUG OWN PRE	- - - -	- - - -	- - - -	- - - -	- - - -	- - - -	- - - -
B-J B9.22 1	V2 21204-243-10 21204-243-10 1204		ISI-21204-243 1.5" PIPE TO REDUCER	ISI AUG OWN PRE	- - - -	- - - -	- - - -	- - - -	- - - -	- - - -	- - - -
B-J B9.22 1	V2 21204-243-11 21204-243-11 1204	ISI/PT/	ISI-21204-243 1.5" TEE TO PIPE	ISI AUG OWN PRE	- - - -	- - - -	- - - -	- - - -	- - - -	s - - -	- - - -
B-J B9.22 1	V2 21204-243-12 21204-243-12 1204		ISI-21204-243 1.5" PIPE TO ELBOW	ISI AUG OWN PRE	- - - -	- - - -	- - - -	- - - -	- - - -	- - - -	- - - -
B-J B9.22 1	V2 21204-243-13 21204-243-13 1204		ISI-21204-243 1.5" ELBOW TO PIPE	ISI AUG OWN PRE	- - - -	- - - -	- - - -	- - - -	- - - -	- - - -	- - - -
B-J B9.22 1	V2 21204-243-14 21204-243-14 1204		ISI-21204-243 1.5" PIPE TO ELBOW	ISI AUG OWN PRE	- - - -	- - - -	- - - -	- - - -	- - - -	- - - -	- - - -
B-J B9.22 1	V2 21204-243-15 21204-243-15 1204		ISI-21204-243 1.5" ELBOW TO PIPE	ISI AUG OWN PRE	- - - -	- - - -	- - - -	- - - -	- - - -	- - - -	- - - -
B-J B9.22 1	V2 21204-243-16 21204-243-16 1204		ISI-21204-243 1.5" PIPE TO PIPE	ISI AUG OWN PRE	- - - -	- - - -	- - - -	- - - -	- - - -	- - - -	- - - -
B-J B9.22 1	V2 21204-243-17 21204-243-17 1204		ISI-21204-243 1.5" PIPE TO ELBOW	ISI AUG OWN PRE	- - - -	- - - -	- - - -	- - - -	- - - -	- - - -	- - - -
B-J B9.22 1	V2 21204-243-18 21204-243-18 1204		ISI-21204-243 1.5" ELBOW TO PIPE	ISI AUG OWN PRE	- - - -	- - - -	- - - -	- - - -	- - - -	- - - -	- - - -

Southern Nuclear Operating Company
3rd Interval
VOGTLE-2 ISI PLAN, VERSION 3.0

Category, Item No., Class	Summary No./CompID/System	Scope / Method / Procedure	Dwg/ISO No. Comp. Desc. Code Case		Period 1		Period 2		Period 3	
					2VR13	2VR14	2VR14A	2VR15	2VR16	2VR17
B-J	V2 21204-243-19		ISI-21204-243	ISI	-	-	-	-	-	-
B9.22	21204-243-19		1.5" PIPE TO ELBOW	AUG	-	-	-	-	-	-
1	1204			OWN	-	-	-	-	-	-
				PRE	-	-	-	-	-	-
B-J	V2 21204-243-2		ISI-21204-243	ISI	-	-	-	-	-	-
B9.22	21204-243-2		1.5" PIPE TO ELBOW	AUG	-	-	-	-	-	-
1	1204			OWN	-	-	-	-	-	-
				PRE	-	-	-	-	-	-
B-J	V2 21204-243-20		ISI-21204-243	ISI	-	-	-	-	-	-
B9.22	21204-243-20		1.5" ELBOW TO PIPE	AUG	-	-	-	-	-	-
1	1204			OWN	-	-	-	-	-	-
				PRE	-	-	-	-	-	-
B-J	V2 21204-243-21		ISI-21204-243	ISI	-	-	-	-	-	-
B9.22	21204-243-21		1.5" PIPE TO ELBOW	AUG	-	-	-	-	-	-
1	1204			OWN	-	-	-	-	-	-
				PRE	-	-	-	-	-	-
B-J	V2 21204-243-22		ISI-21204-243	ISI	-	-	-	-	-	-
B9.22	21204-243-22		1.5" ELBOW TO PIPE	AUG	-	-	-	-	-	-
1	1204			OWN	-	-	-	-	-	-
				PRE	-	-	-	-	-	-
B-J	V2 21204-243-23		ISI-21204-243	ISI	-	-	-	-	-	-
B9.22	21204-243-23		1.5" PIPE TO ELBOW	AUG	-	-	-	-	-	-
1	1204			OWN	-	-	-	-	-	-
				PRE	-	-	-	-	-	-
B-J	V2 21204-243-24		ISI-21204-243	ISI	-	-	-	-	-	-
B9.22	21204-243-24		1.5" ELBOW TO PIPE	AUG	-	-	-	-	-	-
1	1204			OWN	-	-	-	-	-	-
				PRE	-	-	-	-	-	-
B-J	V2 21204-243-25		ISI-21204-243	ISI	-	-	-	-	-	-
B9.22	21204-243-25		1.5" PIPE TO ELBOW	AUG	-	-	-	-	-	-
1	1204			OWN	-	-	-	-	-	-
				PRE	-	-	-	-	-	-
B-J	V2 21204-243-26		ISI-21204-243	ISI	-	-	-	-	-	-
B9.22	21204-243-26		1.5" ELBOW TO PIPE	AUG	-	-	-	-	-	-
1	1204			OWN	-	-	-	-	-	-
				PRE	-	-	-	-	-	-
B-J	V2 21204-243-27		ISI-21204-243	ISI	-	-	-	-	-	-
B9.22	21204-243-27		1.5" PIPE TO ELBOW	AUG	-	-	-	-	-	-
1	1204			OWN	-	-	-	-	-	-
				PRE	-	-	-	-	-	-

**Southern Nuclear Operating Company
3rd Interval
VOGTLE-2 ISI PLAN, VERSION 3.0**

Category, Item No., Class	Summary No./CompID/System	Scope / Method / Procedure	Dwg/ISO No. Comp. Desc. Code Case		Period 1		Period 2		Period 3		
					2VR13	2VR14	2VR14A	2VR15	2VR16	2VR17	2VR18
B-J B9.22 1	V2 21204-243-28 21204-243-28 1204		ISI-21204-243 1.5" ELBOW TO PIPE	ISI AUG OWN PRE	-	-	-	-	-	-	-
B-J B9.22 1	V2 21204-243-3 21204-243-3 1204		ISI-21204-243 1.5" ELBOW TO PIPE	ISI AUG OWN PRE	-	-	-	-	-	-	-
B-J B9.22 1	V2 21204-243-31 21204-243-31 1204	ISI/UT/NMP-ES-024-501	ISI-21204-243 1.5" PIPE TO ELBOW	ISI AUG OWN PRE	c	-	-	-	-	-	-
B-J B9.22 1	V2 21204-243-32 21204-243-32 1204	ISI/UT/NMP-ES-024-501	ISI-21204-243 1.5" ELBOW TO PIPE	ISI AUG OWN PRE	c	-	-	-	-	-	-
B-J B9.22 1	V2 21204-243-33 21204-243-33 1204		ISI-21204-243 1.5" PIPE TO REDUCER	ISI AUG OWN PRE	-	-	-	-	-	-	-
B-J B9.22 1	V2 21204-243-34 21204-243-34 1204	ISI/UT/NMP-ES-024-501	ISI-21204-243 3" REDUCER TO BRANCH CONNECTION	ISI AUG OWN PRE	c	-	-	-	-	-	-
B-J B9.22 1	V2 21204-243-4 21204-243-4 1204	ISI/PT/	ISI-21204-243 1.5" PIPE TO TEE	ISI AUG OWN PRE	-	-	-	-	-	s	-
B-J B9.22 1	V2 21204-243-5 21204-243-5 1204	ISI/PT/	ISI-21204-243 1.5" TEE TO PIPE	ISI AUG OWN PRE	-	-	-	-	-	s	-
B-J B9.22 1	V2 21204-243-6 21204-243-6 1204	ISI/PT/	ISI-21204-243 1.5" PIPE TO ELBOW	ISI AUG OWN PRE	-	-	-	-	-	s	-
B-J B9.22 1	V2 21204-243-7 21204-243-7 1204		ISI-21204-243 1.5" ELBOW TO PIPE	ISI AUG OWN	-	-	-	-	-	-	-

Southern Nuclear Operating Company
3rd Interval
VOGTLE-2 ISI PLAN, VERSION 3.0

Category, Item No., Class	Summary No./CompID/System	Scope / Method / Procedure	Dwg/ISO No. Comp. Desc. Code Case		Period 1		Period 2		Period 3	
					2VR13	2VR14	2VR14A	2VR15	2VR16	2VR17
				PRE	-	-	-	-	-	-
B-J	V2 21204-243-8		ISI-21204-243	ISI	-	-	-	-	-	-
B9.22	21204-243-8		1.5" PIPE TO ELBOW	AUG	-	-	-	-	-	-
1	1204			OWN	-	-	-	-	-	-
				PRE	-	-	-	-	-	-
B-J	V2 21204-243-9		ISI-21204-243	ISI	-	-	-	-	-	-
B9.22	21204-243-9		1.5" ELBOW TO PIPE	AUG	-	-	-	-	-	-
1	1204			OWN	-	-	-	-	-	-
				PRE	-	-	-	-	-	-
B-J	V2 21204-244-10		ISI-21204-244	ISI	-	-	-	-	-	-
B9.22	21204-244-10		1.5" PIPE TO ELBOW	AUG	-	-	-	-	-	-
1	1204			OWN	-	-	-	-	-	-
				PRE	-	-	-	-	-	-
B-J	V2 21204-244-11		ISI-21204-244	ISI	-	-	-	-	-	-
B9.22	21204-244-11		1.5" ELBOW TO PIPE	AUG	-	-	-	-	-	-
1	1204			OWN	-	-	-	-	-	-
				PRE	-	-	-	-	-	-
B-J	V2 21204-244-12		ISI-21204-244	ISI	-	-	-	-	-	-
B9.22	21204-244-12		1.5" PIPE TO ELBOW	AUG	-	-	-	-	-	-
1	1204			OWN	-	-	-	-	-	-
				PRE	-	-	-	-	-	-
B-J	V2 21204-244-13		ISI-21204-244	ISI	-	-	-	-	-	-
B9.22	21204-244-13		1.5" ELBOW TO PIPE	AUG	-	-	-	-	-	-
1	1204			OWN	-	-	-	-	-	-
				PRE	-	-	-	-	-	-
B-J	V2 21204-244-14		ISI-21204-244	ISI	-	-	-	-	-	-
B9.22	21204-244-14		1.5" PIPE TO ELBOW	AUG	-	-	-	-	-	-
1	1204			OWN	-	-	-	-	-	-
				PRE	-	-	-	-	-	-
B-J	V2 21204-244-15		ISI-21204-244	ISI	-	-	-	-	-	-
B9.22	21204-244-15		1.5" ELBOW TO PIPE	AUG	-	-	-	-	-	-
1	1204			OWN	-	-	-	-	-	-
				PRE	-	-	-	-	-	-
B-J	V2 21204-244-16		ISI-21204-244	ISI	-	-	-	-	-	-
B9.22	21204-244-16		1.5" PIPE TO PIPE	AUG	-	-	-	-	-	-
1	1204			OWN	-	-	-	-	-	-
				PRE	-	-	-	-	-	-
B-J	V2 21204-244-17	ISI/PT/	ISI-21204-244	ISI	-	-	-	-	s	-
B9.22	21204-244-17		1.5" PIPE TO ELBOW	AUG	-	-	-	-	-	-
1	1204			OWN	-	-	-	-	-	-

Southern Nuclear Operating Company
3rd Interval
VOGTLE-2 ISI PLAN, VERSION 3.0

Category, Item No., Class	Summary No./ComplID/System	Scope / Method / Procedure	Dwg/ISO No. Comp. Desc. Code Case		Period 1		Period 2			Period 3	
					2VR13	2VR14	2VR14A	2VR15	2VR16	2VR17	2VR18
				PRE	-	-	-	-	-	-	-
B-J	V2 21204-244-18	ISI/PT/	ISI-21204-244	ISI	-	-	-	-	-	s	-
B9.22	21204-244-18		1.5" ELBOW TO PIPE	AUG	-	-	-	-	-	-	-
1	1204			OWN	-	-	-	-	-	-	-
				PRE	-	-	-	-	-	-	-
B-J	V2 21204-244-19	ISI/PT/	ISI-21204-244	ISI	-	-	-	-	-	s	-
B9.22	21204-244-19		1.5" PIPE TO ELBOW	AUG	-	-	-	-	-	-	-
1	1204			OWN	-	-	-	-	-	-	-
				PRE	-	-	-	-	-	-	-
B-J	V2 21204-244-2	ISI/PT/	ISI-21204-244	ISI	-	-	-	-	-	s	-
B9.22	21204-244-2		1.5" PIPE TO ELBOW	AUG	-	-	-	-	-	-	-
1	1204			OWN	-	-	-	-	-	-	-
				PRE	-	-	-	-	-	-	-
B-J	V2 21204-244-20		ISI-21204-244	ISI	-	-	-	-	-	-	-
B9.22	21204-244-20		1.5" ELBOW TO PIPE	AUG	-	-	-	-	-	-	-
1	1204			OWN	-	-	-	-	-	-	-
				PRE	-	-	-	-	-	-	-
B-J	V2 21204-244-21		ISI-21204-244	ISI	-	-	-	-	-	-	-
B9.22	21204-244-21		1.5" PIPE TO ELBOW	AUG	-	-	-	-	-	-	-
1	1204			OWN	-	-	-	-	-	-	-
				PRE	-	-	-	-	-	-	-
B-J	V2 21204-244-22		ISI-21204-244	ISI	-	-	-	-	-	-	-
B9.22	21204-244-22		1.5" ELBOW TO PIPE	AUG	-	-	-	-	-	-	-
1	1204			OWN	-	-	-	-	-	-	-
				PRE	-	-	-	-	-	-	-
B-J	V2 21204-244-23		ISI-21204-244	ISI	-	-	-	-	-	-	-
B9.22	21204-244-23		1.5" PIPE TO ELBOW	AUG	-	-	-	-	-	-	-
1	1204			OWN	-	-	-	-	-	-	-
				PRE	-	-	-	-	-	-	-
B-J	V2 21204-244-24		ISI-21204-244	ISI	-	-	-	-	-	-	-
B9.22	21204-244-24		1.5" ELBOW TO PIPE	AUG	-	-	-	-	-	-	-
1	1204			OWN	-	-	-	-	-	-	-
				PRE	-	-	-	-	-	-	-
B-J	V2 21204-244-25		ISI-21204-244	ISI	-	-	-	-	-	-	-
B9.22	21204-244-25		1.5" PIPE TO ELBOW	AUG	-	-	-	-	-	-	-
1	1204			OWN	-	-	-	-	-	-	-
				PRE	-	-	-	-	-	-	-
B-J	V2 21204-244-26		ISI-21204-244	ISI	-	-	-	-	-	-	-
B9.22	21204-244-26		1.5" ELBOW TO PIPE	AUG	-	-	-	-	-	-	-
1	1204			OWN	-	-	-	-	-	-	-

Southern Nuclear Operating Company
3rd Interval
VOGTLE-2 ISI PLAN, VERSION 3.0

Category, Item No., Class	Summary No./ComplID/System	Scope / Method / Procedure	Dwg/ISO No. Comp. Desc. Code Case	PRE	Period 1		Period 2			Period 3	
					2VR13	2VR14	2VR14A	2VR15	2VR16	2VR17	2VR18
B-J B9.22 1	V2 21204-244-29 21204-244-29 1204	ISI/UT/NMP-ES-024-501	ISI-21204-244 1.5" PIPE TO ELBOW	ISI AUG OWN PRE	c - - -	- - - -	- - - -	- - - -	- - - -	- - - -	- - - -
B-J B9.22 1	V2 21204-244-3 21204-244-3 1204		ISI-21204-244 1.5" ELBOW TO PIPE	ISI AUG OWN PRE	- - - -	- - - -	- - - -	- - - -	- - - -	- - - -	- - - -
B-J B9.22 1	V2 21204-244-30 21204-244-30 1204	ISI/UT/NMP-ES-024-501	ISI-21204-244 1.5" ELBOW TO PIPE	ISI AUG OWN PRE	c - - -	- - - -	- - - -	- - - -	- - - -	- - - -	- - - -
B-J B9.22 1	V2 21204-244-31 21204-244-31 1204		ISI-21204-244 1.5" PIPE TO REDUCER	ISI AUG OWN PRE	- - - -	- - - -	- - - -	- - - -	- - - -	- - - -	- - - -
B-J B9.22 1	V2 21204-244-32 21204-244-32 1204	ISI/UT/NMP-ES-024-501	ISI-21204-244 3" REDUCER TO BRANCH CONNECTION	ISI AUG OWN PRE	c - - -	- - - -	- - - -	- - - -	- - - -	- - - -	- - - -
B-J B9.22 1	V2 21204-244-33 21204-244-33 1204	ISI/PT/	ISI-21204-244 1.5" TEE TO PIPE	ISI AUG OWN PRE	- - - -	- - - -	- - - -	- - - -	- - - -	- - - -	s - - -
B-J B9.22 1	V2 21204-244-33 A 21204-244-33 A 1204		ISI-21204-244 1.5" PIPE TO ELBOW	ISI AUG OWN PRE	- - - -	- - - -	- - - -	- - - -	- - - -	- - - -	- - - -
B-J B9.22 1	V2 21204-244-34 21204-244-34 1204	ISI/PT/	ISI-21204-244 1.5" ELBOW TO PIPE	ISI AUG OWN PRE	- - - -	- - - -	- - - -	- - - -	- - - -	- - - -	s - - -
B-J B9.22 1	V2 21204-244-35 21204-244-35 1204		ISI-21204-244 1.5" PIPE TO ELBOW	ISI AUG OWN PRE	- - - -	- - - -	- - - -	- - - -	- - - -	- - - -	- - - -
B-J B9.22	V2 21204-244-36 21204-244-36		ISI-21204-244 1.5" ELBOW TO PIPE	ISI AUG	- - -	- - -	- - -	- - -	- - -	- - -	- - -

**Southern Nuclear Operating Company
3rd Interval
VOGTLE-2 ISI PLAN, VERSION 3.0**

Category, Item No., Class	Summary No./CompID/System	Scope / Method / Procedure	Dwg/ISO No. Comp. Desc. Code Case		Period 1		Period 2		Period 3	
					2VR13	2VR14	2VR14A	2VR15	2VR16	2VR17
1	1204			OWN PRE	-	-	-	-	-	-
B-J B9.22 1	V2 21204-244-37 21204-244-37 1204		ISI-21204-244 1.5" PIPE TO REDUCER	ISI AUG OWN PRE	-	-	-	-	-	-
B-J B9.22 1	V2 21204-244-4 21204-244-4 1204		ISI-21204-244 1.5" PIPE TO ELBOW	ISI AUG OWN PRE	-	-	-	-	-	-
B-J B9.22 1	V2 21204-244-5 21204-244-5 1204		ISI-21204-244 1.5" ELBOW TO PIPE	ISI AUG OWN PRE	-	-	-	-	-	-
B-J B9.22 1	V2 21204-244-6 21204-244-6 1204		ISI-21204-244 1.5" PIPE TO TEE	ISI AUG OWN PRE	-	-	-	-	-	-
B-J B9.22 1	V2 21204-244-7 21204-244-7 1204		ISI-21204-244 1.5" TEE TO PIPE	ISI AUG OWN PRE	-	-	-	-	-	-
B-J B9.22 1	V2 21204-244-8 21204-244-8 1204		ISI-21204-244 1.5" PIPE TO ELBOW	ISI AUG OWN PRE	-	-	-	-	-	-
B-J B9.22 1	V2 21204-244-9 21204-244-9 1204		ISI-21204-244 1.5" ELBOW TO PIPE	ISI AUG OWN PRE	-	-	-	-	-	-
B-J B9.22 1	V2 21204-245-10 21204-245-10 1204		ISI-21204-245 1.5" PIPE TO ELBOW	ISI AUG OWN PRE	-	-	-	-	-	-
B-J B9.22 1	V2 21204-245-11 21204-245-11 1204		ISI-21204-245 1.5" ELBOW TO PIPE	ISI AUG OWN PRE	-	-	-	-	-	-
B-J B9.22	V2 21204-245-12 21204-245-12		ISI-21204-245 1.5" PIPE TO PIPE	ISI AUG	-	-	-	-	-	-

Southern Nuclear Operating Company
3rd Interval
VOGTLE-2 ISI PLAN, VERSION 3.0

Category, Item No., Class	Summary No./ComplD/System	Scope / Method / Procedure	Dwg/ISO No. Comp. Desc. Code Case		Period 1		Period 2			Period 3	
					2VR13	2VR14	2VR14A	2VR15	2VR16	2VR17	2VR18
1	1204			OWN PRE	-	-	-	-	-	-	-
B-J B9.22 1	V2 21204-245-13 21204-245-13 1204		ISI-21204-245 1.5" PIPE TO ELBOW	ISI AUG OWN PRE	-	-	-	-	-	-	-
B-J B9.22 1	V2 21204-245-14 21204-245-14 1204		ISI-21204-245 1.5" ELBOW TO PIPE	ISI AUG OWN PRE	-	-	-	-	-	-	-
B-J B9.22 1	V2 21204-245-15 21204-245-15 1204		ISI-21204-245 1.5" PIPE TO ELBOW	ISI AUG OWN PRE	-	-	-	-	-	-	-
B-J B9.22 1	V2 21204-245-16 21204-245-16 1204		ISI-21204-245 1.5" ELBOW TO PIPE	ISI AUG OWN PRE	-	-	-	-	-	-	-
B-J B9.22 1	V2 21204-245-17 21204-245-17 1204		ISI-21204-245 1.5" PIPE TO ELBOW	ISI AUG OWN PRE	-	-	-	-	-	-	-
B-J B9.22 1	V2 21204-245-18 21204-245-18 1204		ISI-21204-245 1.5" ELBOW TO PIPE	ISI AUG OWN PRE	-	-	-	-	-	-	-
B-J B9.22 1	V2 21204-245-19 21204-245-19 1204		ISI-21204-245 1.5" PIPE TO ELBOW	ISI AUG OWN PRE	-	-	-	-	-	-	-
B-J B9.22 1	V2 21204-245-2 21204-245-2 1204		ISI-21204-245 1.5" PIPE TO ELBOW	ISI AUG OWN PRE	-	-	-	-	-	-	-
B-J B9.22 1	V2 21204-245-20 21204-245-20 1204		ISI-21204-245 1.5" ELBOW TO PIPE	ISI AUG OWN PRE	-	-	-	-	-	-	-
B-J B9.22	V2 21204-245-21 21204-245-21		ISI-21204-245 1.5" PIPE TO ELBOW	ISI AUG	-	-	-	-	-	-	-

Southern Nuclear Operating Company
3rd Interval
VOGTLE-2 ISI PLAN, VERSION 3.0

Category, Item No., Class	Summary No./CompID/System	Scope / Method / Procedure	Dwg/ISO No. Comp. Desc. Code Case		Period 1		Period 2			Period 3	
					2VR13	2VR14	2VR14A	2VR15	2VR16	2VR17	2VR18
	1204			OWN	-	-	-	-	-	-	-
	1204			PRE	-	-	-	-	-	-	-
B-J	V2 21204-245-22		ISI-21204-245	ISI	-	-	-	-	-	-	-
B9.22	21204-245-22		1.5" ELBOW TO PIPE	AUG	-	-	-	-	-	-	-
1	1204			OWN	-	-	-	-	-	-	-
	1204			PRE	-	-	-	-	-	-	-
B-J	V2 21204-245-23	ISI/PT/	ISI-21204-245	ISI	-	-	-	-	-	s	-
B9.22	21204-245-23		1.5" PIPE TO ELBOW	AUG	-	-	-	-	-	-	-
1	1204			OWN	-	-	-	-	-	-	-
	1204			PRE	-	-	-	-	-	-	-
B-J	V2 21204-245-24	ISI/PT/	ISI-21204-245	ISI	-	-	-	-	-	s	-
B9.22	21204-245-24		1.5" ELBOW TO PIPE	AUG	-	-	-	-	-	-	-
1	1204			OWN	-	-	-	-	-	-	-
	1204			PRE	-	-	-	-	-	-	-
B-J	V2 21204-245-25	ISI/PT/	ISI-21204-245	ISI	-	-	-	-	-	s	-
B9.22	21204-245-25		1.5" PIPE TO ELBOW	AUG	-	-	-	-	-	-	-
1	1204			OWN	-	-	-	-	-	-	-
	1204			PRE	-	-	-	-	-	-	-
B-J	V2 21204-245-26	ISI/PT/	ISI-21204-245	ISI	-	-	-	-	-	s	-
B9.22	21204-245-26		1.5" ELBOW TO PIPE	AUG	-	-	-	-	-	-	-
1	1204			OWN	-	-	-	-	-	-	-
	1204			PRE	-	-	-	-	-	-	-
B-J	V2 21204-245-27		ISI-21204-245	ISI	-	-	-	-	-	-	-
B9.22	21204-245-27		1.5" PIPE TO ELBOW	AUG	-	-	-	-	-	-	-
1	1204			OWN	-	-	-	-	-	-	-
	1204			PRE	-	-	-	-	-	-	-
B-J	V2 21204-245-28		ISI-21204-245	ISI	-	-	-	-	-	-	-
B9.22	21204-245-28		1.5" ELBOW TO PIPE	AUG	-	-	-	-	-	-	-
1	1204			OWN	-	-	-	-	-	-	-
	1204			PRE	-	-	-	-	-	-	-
B-J	V2 21204-245-3		ISI-21204-245	ISI	-	-	-	-	-	-	-
B9.22	21204-245-3		1.5" ELBOW TO PIPE	AUG	-	-	-	-	-	-	-
1	1204			OWN	-	-	-	-	-	-	-
	1204			PRE	-	-	-	-	-	-	-
B-J	V2 21204-245-31	ISI/UT/NMP-ES-024-501	ISI-21204-245	ISI	c	-	-	-	-	-	-
B9.22	21204-245-31		1.5" PIPE TO ELBOW	AUG	-	-	-	-	-	-	-
1	1204			OWN	-	-	-	-	-	-	-
	1204			PRE	-	-	-	-	-	-	-
B-J	V2 21204-245-32	ISI/UT/NMP-ES-024-501	ISI-21204-245	ISI	c	-	-	-	-	-	-
B9.22	21204-245-32		1.5" ELBOW TO PIPE	AUG	-	-	-	-	-	-	-

Southern Nuclear Operating Company
3rd Interval
VOGTLE-2 ISI PLAN, VERSION 3.0

Category, Item No., Class	Summary No./ComplID/System	Scope / Method / Procedure	Dwg/ISO No. Comp. Desc. Code Case		Period 1		Period 2			Period 3	
					2VR13	2VR14	2VR14A	2VR15	2VR16	2VR17	2VR18
	1 1204			OWN PRE	-	-	-	-	-	-	-
B-J B9.22 1	V2 21204-245-33 21204-245-33 1204		ISI-21204-245 1.5" PIPE TO REDUCER	ISI AUG OWN PRE	-	-	-	-	-	-	-
B-J B9.22 1	V2 21204-245-34 21204-245-34 1204	ISI/UT/NMP-ES-024-501	ISI-21204-245 3" REDUCER TO BRANCH CONNECTION	ISI AUG OWN PRE	c	-	-	-	-	-	-
B-J B9.22 1	V2 21204-245-35 21204-245-35 1204	ISI/PT/	ISI-21204-245 1.5" TEE TO PIPE	ISI AUG OWN PRE	-	-	-	-	-	s	-
B-J B9.22 1	V2 21204-245-36 21204-245-36 1204		ISI-21204-245 1.5" PIPE TO ELBOW	ISI AUG OWN PRE	-	-	-	-	-	-	-
B-J B9.22 1	V2 21204-245-37 21204-245-37 1204		ISI-21204-245 1.5" ELBOW TO PIPE	ISI AUG OWN PRE	-	-	-	-	-	-	-
B-J B9.22 1	V2 21204-245-38 21204-245-38 1204		ISI-21204-245 1.5" PIPE TO ELBOW	ISI AUG OWN PRE	-	-	-	-	-	-	-
B-J B9.22 1	V2 21204-245-39 21204-245-39 1204		ISI-21204-245 1.5" ELBOW TO PIPE	ISI AUG OWN PRE	-	-	-	-	-	-	-
B-J B9.22 1	V2 21204-245-4 21204-245-4 1204		ISI-21204-245 1.5" PIPE TO ELBOW	ISI AUG OWN PRE	-	-	-	-	-	-	-
B-J B9.22 1	V2 21204-245-40 21204-245-40 1204		ISI-21204-245 1.5" PIPE TO REDUCER	ISI AUG OWN PRE	-	-	-	-	-	-	-
B-J	V2 21204-245-5		ISI-21204-245	ISI	-	-	-	-	-	-	-

Southern Nuclear Operating Company
3rd Interval
VOGTLE-2 ISI PLAN, VERSION 3.0

Category, Item No., Class	Summary No./CompID/System	Scope / Method / Procedure	Dwg/ISO No. Comp. Desc. Code Case		Period 1		Period 2			Period 3	
					2VR13	2VR14	2VR14A	2VR15	2VR16	2VR17	2VR18
B9.22 1	21204-245-5 1204		1.5" ELBOW TO PIPE	AUG OWN PRE	- - -	- - -	- - -	- - -	- - -	- - -	- - -
B-J B9.22 1	V2 21204-245-6 21204-245-6 1204		ISI-21204-245 1.5" PIPE TO TEE	ISI AUG OWN PRE	- - -	- - -	- - -	- - -	- - -	- - -	- - -
B-J B9.22 1	V2 21204-245-7 21204-245-7 1204		ISI-21204-245 1.5" TEE TO PIPE	ISI AUG OWN PRE	- - -	- - -	- - -	- - -	- - -	- - -	- - -
B-J B9.22 1	V2 21204-245-8 21204-245-8 1204		ISI-21204-245 1.5" PIPE TO ELBOW	ISI AUG OWN PRE	- - -	- - -	- - -	- - -	- - -	- - -	- - -
B-J B9.22 1	V2 21204-245-9 21204-245-9 1204		ISI-21204-245 1.5" ELBOW TO PIPE	ISI AUG OWN PRE	- - -	- - -	- - -	- - -	- - -	- - -	- - -
B-J B9.22 1	V2 21204-246-10 21204-246-10 1204		ISI-21204-246 1.5" PIPE TO ELBOW	ISI AUG OWN PRE	- - -	- - -	- - -	- - -	- - -	- - -	- - -
B-J B9.22 1	V2 21204-246-11 21204-246-11 1204		ISI-21204-246 1.5" ELBOW TO PIPE	ISI AUG OWN PRE	- - -	- - -	- - -	- - -	- - -	- - -	- - -
B-J B9.22 1	V2 21204-246-12 21204-246-12 1204		ISI-21204-246 1.5" PIPE TO REDUCER	ISI AUG OWN PRE	- - -	- - -	- - -	- - -	- - -	- - -	- - -
B-J B9.22 1	V2 21204-246-13 21204-246-13 1204	ISI/PT/	ISI-21204-246 1.5" TEE TO PIPE	ISI AUG OWN PRE	- - -	- - -	- - -	- - -	- - -	- - -	- - -
B-J B9.22 1	V2 21204-246-14 21204-246-14 1204		ISI-21204-246 1.5" PIPE TO ELBOW	ISI AUG OWN PRE	- - -	- - -	- - -	- - -	- - -	- - -	- - -
B-J	V2 21204-246-15		ISI-21204-246	ISI	-	-	-	-	-	-	-

**Southern Nuclear Operating Company
3rd Interval
VOGTLE-2 ISI PLAN, VERSION 3.0**

Category, Item No., Class	Summary No./ComplID/System	Scope / Method / Procedure	Dwg/ISO No. Comp. Desc. Code Case		Period 1		Period 2		Period 3	
					2VR13	2VR14	2VR14A	2VR15	2VR16	2VR17
B9.22 1	21204-246-15 1204		1.5" ELBOW TO PIPE	AUG OWN PRE	- - -	- - -	- - -	- - -	- - -	- - -
B-J B9.22 1	V2 21204-246-16 21204-246-16 1204		ISI-21204-246 1.5" PIPE TO ELBOW	ISI AUG OWN PRE	- - -	- - -	- - -	- - -	- - -	- - -
B-J B9.22 1	V2 21204-246-17 21204-246-17 1204		ISI-21204-246 1.5" ELBOW TO PIPE	ISI AUG OWN PRE	- - -	- - -	- - -	- - -	- - -	- - -
B-J B9.22 1	V2 21204-246-18 21204-246-18 1204		ISI-21204-246 1.5" PIPE TO PIPE	ISI AUG OWN PRE	- - -	- - -	- - -	- - -	- - -	- - -
B-J B9.22 1	V2 21204-246-19 21204-246-19 1204		ISI-21204-246 1.5" PIPE TO ELBOW	ISI AUG OWN PRE	- - -	- - -	- - -	- - -	- - -	- - -
B-J B9.22 1	V2 21204-246-2 21204-246-2 1204		ISI-21204-246 1.5" PIPE TO ELBOW	ISI AUG OWN PRE	- - -	- - -	- - -	- - -	- - -	- - -
B-J B9.22 1	V2 21204-246-20 21204-246-20 1204		ISI-21204-246 1.5" ELBOW TO PIPE	ISI AUG OWN PRE	- - -	- - -	- - -	- - -	- - -	- - -
B-J B9.22 1	V2 21204-246-21 21204-246-21 1204		ISI-21204-246 1.5" PIPE TO ELBOW	ISI AUG OWN PRE	- - -	- - -	- - -	- - -	- - -	- - -
B-J B9.22 1	V2 21204-246-22 21204-246-22 1204		ISI-21204-246 1.5" ELBOW TO PIPE	ISI AUG OWN PRE	- - -	- - -	- - -	- - -	- - -	- - -
B-J B9.22 1	V2 21204-246-23 21204-246-23 1204		ISI-21204-246 1.5" PIPE TO ELBOW	ISI AUG OWN PRE	- - -	- - -	- - -	- - -	- - -	- - -
B-J	V2 21204-246-24		ISI-21204-246	ISI	-	-	-	-	-	-

**Southern Nuclear Operating Company
3rd Interval
VOGTLE-2 ISI PLAN, VERSION 3.0**

Category, Item No., Class	Summary No./CompID/System	Scope / Method / Procedure	Dwg/ISO No. Comp. Desc. Code Case		Period 1		Period 2		Period 3	
					2VR13	2VR14	2VR14A	2VR15	2VR16	2VR17
B9.22 1	21204-246-24 1204		1.5" ELBOW TO PIPE	AUG OWN PRE	- - -	- - -	- - -	- - -	- - -	- - -
B-J B9.22 1	V2 21204-246-25 21204-246-25 1204	ISI/PT/	ISI-21204-246 1.5" PIPE TO ELBOW	ISI AUG OWN PRE	- - - -	- - - -	s - - -	- - - -	- - - -	- - - -
B-J B9.22 1	V2 21204-246-26 21204-246-26 1204	ISI/PT/	ISI-21204-246 1.5" ELBOW TO PIPE	ISI AUG OWN PRE	- - - -	- - - -	s - - -	- - - -	- - - -	- - - -
B-J B9.22 1	V2 21204-246-27 21204-246-27 1204	ISI/PT/	ISI-21204-246 1.5" PIPE TO ELBOW	ISI AUG OWN PRE	- - - -	- - - -	s - - -	- - - -	- - - -	- - - -
B-J B9.22 1	V2 21204-246-28 21204-246-28 1204	ISI/PT/	ISI-21204-246 1.5" ELBOW TO PIPE	ISI AUG OWN PRE	- - - -	- - - -	s - - -	- - - -	- - - -	- - - -
B-J B9.22 1	V2 21204-246-29 21204-246-29 1204		ISI-21204-246 1.5" PIPE TO ELBOW	ISI AUG OWN PRE	- - - -	- - - -	- - - -	- - - -	- - - -	- - - -
B-J B9.22 1	V2 21204-246-3 21204-246-3 1204		ISI-21204-246 1.5" ELBOW TO PIPE	ISI AUG OWN PRE	- - - -	- - - -	- - - -	- - - -	- - - -	- - - -
B-J B9.22 1	V2 21204-246-30 21204-246-30 1204		ISI-21204-246 1.5" ELBOW TO PIPE	ISI AUG OWN PRE	- - - -	- - - -	- - - -	- - - -	- - - -	- - - -
B-J B9.22 1	V2 21204-246-33 21204-246-33 1204	ISI/UT/NMP-ES-024-501	ISI-21204-246 1.5" PIPE TO ELBOW	ISI AUG OWN PRE	c - - -	- - - -	- - - -	- - - -	- - - -	- - - -
B-J B9.22 1	V2 21204-246-34 21204-246-34 1204	ISI/UT/NMP-ES-024-501	ISI-21204-246 1.5" ELBOW TO PIPE	ISI AUG OWN PRE	c - - -	- - - -	- - - -	- - - -	- - - -	- - - -
B-J	V2 21204-246-35		ISI-21204-246	ISI	-	-	-	-	-	-

**Southern Nuclear Operating Company
3rd Interval
VOGTLE-2 ISI PLAN, VERSION 3.0**

Category, Item No., Class	Summary No./CompID/System	Scope / Method / Procedure	Dwg/ISO No. Comp. Desc. Code Case		Period 1		Period 2		Period 3	
					2VR13	2VR14	2VR14A	2VR15	2VR16	2VR17
B9.22 1	21204-246-35 1204		1.5" PIPE TO REDUCER	AUG OWN PRE	- - -	- - -	- - -	- - -	- - -	- - -
B-J	V2 21204-246-36	ISI/UT/NMP-ES-024-501	ISI-21204-246	ISI	c	-	-	-	-	-
B9.22 1	21204-246-36 1204		3" REDUCER TO BRANCH CONNECTION	AUG OWN PRE	- - -	- - -	- - -	- - -	- - -	- - -
B-J	V2 21204-246-4		ISI-21204-246	ISI	-	-	-	-	-	-
B9.22 1	21204-246-4 1204		1.5" PIPE TO ELBOW	AUG OWN PRE	- - -	- - -	- - -	- - -	- - -	- - -
B-J	V2 21204-246-5		ISI-21204-246	ISI	-	-	-	-	-	-
B9.22 1	21204-246-5 1204		1.5" ELBOW TO PIPE	AUG OWN PRE	- - -	- - -	- - -	- - -	- - -	- - -
B-J	V2 21204-246-6		ISI-21204-246	ISI	-	-	-	-	-	-
B9.22 1	21204-246-6 1204		1.5" PIPE TO TEE	AUG OWN PRE	- - -	- - -	- - -	- - -	- - -	- - -
B-J	V2 21204-246-7		ISI-21204-246	ISI	-	-	-	-	-	-
B9.22 1	21204-246-7 1204		1.5" TEE TO PIPE	AUG OWN PRE	- - -	- - -	- - -	- - -	- - -	- - -
B-J	V2 21204-246-8		ISI-21204-246	ISI	-	-	-	-	-	-
B9.22 1	21204-246-8 1204		1.5" PIPE TO ELBOW	AUG OWN PRE	- - -	- - -	- - -	- - -	- - -	- - -
B-J	V2 21204-246-9		ISI-21204-246	ISI	-	-	-	-	-	-
B9.22 1	21204-246-9 1204		1.5" ELBOW TO PIPE	AUG OWN PRE	- - -	- - -	- - -	- - -	- - -	- - -
B-J	V2 21201-001-2		ISI-21201-001	ISI	-	-	-	-	-	-
B9.31 1	21201-001-2 1201		29" PIPE TO 12" BRANCH CONNECTION	AUG OWN PRE	- - -	- - -	- - -	- - -	- - -	- - -
B-J	V2 21201-002-2		ISI-21201-002	ISI	-	-	-	-	-	-
B9.31 1	21201-002-2 1201		29" PIPE TO 6" BRANCH CONNECTION	AUG OWN PRE	- - -	- - -	- - -	- - -	- - -	- - -

Southern Nuclear Operating Company
3rd Interval
VOGTLE-2 ISI PLAN, VERSION 3.0

Category, Item No., Class	Summary No./ComplD/System	Scope / Method / Procedure	Dwg/ISO No. Comp. Desc. Code Case		Period 1		Period 2			Period 3	
					2VR13	2VR14	2VR14A	2VR15	2VR16	2VR17	2VR18
B-J	V2 21201-003-2	ISI/UT/	ISI-21201-003	ISI	-	-	-	-	-	-	-
B9.31	21201-003-2		29" PIPE TO 6" BRANCH CONNECTION	AUG	-	-	-	-	-	-	-
1	1201			OWN	-	-	-	-	-	-	-
				PRE	-	-	-	-	-	-	-
B-J	V2 21201-004-2	ISI/UT/	ISI-21201-004	ISI	-	-	-	s	-	-	-
B9.31	21201-004-2		29" PIPE TO 16" BRANCH CONNECTION	AUG	-	-	-	-	-	-	-
1	1201			OWN	-	-	-	-	-	-	-
				PRE	-	-	-	-	-	-	-
B-J	V2 21201-004-3	ISI/UT/	ISI-21201-004	ISI	-	-	-	s	-	-	-
B9.31	21201-004-3		29" PIPE TO 12" BRANCH CONNECTION	AUG	-	-	-	-	-	-	-
1	1201			OWN	-	-	-	-	-	-	-
				PRE	-	-	-	-	-	-	-
B-J	V2 21201-009-4		ISI-21201-009	ISI	-	-	-	-	-	-	-
B9.31	21201-009-4		27.5" PIPE TO 4" BRANCH CONNECTION	AUG	-	-	-	-	-	-	-
1	1201			OWN	-	-	-	-	-	-	-
				PRE	-	-	-	-	-	-	-
B-J	V2 21201-009-6		ISI-21201-009	ISI	-	-	-	-	-	-	-
B9.31	21201-009-6		27.5" PIPE TO 10" BRANCH CONNECTION	AUG	-	-	-	-	-	-	-
1	1201			OWN	-	-	-	-	-	-	-
				PRE	-	-	-	-	-	-	-
B-J	V2 21201-010-4		ISI-21201-010	ISI	-	-	-	-	-	-	-
B9.31	21201-010-4		27.5" PIPE TO 10" BRANCH CONNECTION	AUG	-	-	-	-	-	-	-
1	1201			OWN	-	-	-	-	-	-	-
				PRE	-	-	-	-	-	-	-
B-J	V2 21201-011-5		ISI-21201-011	ISI	-	-	-	-	-	-	-
B9.31	21201-011-5		27.5" PIPE TO 10" BRANCH CONNECTION	AUG	-	-	-	-	-	-	-
1	1201			OWN	-	-	-	-	-	-	-
				PRE	-	-	-	-	-	-	-
B-J	V2 21201-012-4		ISI-21201-012	ISI	-	-	-	-	-	-	-
B9.31	21201-012-4		27.5" PIPE TO 4" BRANCH CONNECTION	AUG	-	-	-	-	-	-	-
1	1201			OWN	-	-	-	-	-	-	-
				PRE	-	-	-	-	-	-	-
B-J	V2 21201-012-6		ISI-21201-012	ISI	-	-	-	-	-	-	-
B9.31	21201-012-6		27.5" PIPE TO 10" BRANCH CONNECTION	AUG	-	-	-	-	-	-	-

**Southern Nuclear Operating Company
3rd Interval
VOGTLE-2 ISI PLAN, VERSION 3.0**

Category, Item No., Class	Summary No./ComplID/System	Scope / Method / Procedure	Dwg/ISO No. Comp. Desc. Code Case		Period 1		Period 2			Period 3	
					2VR13	2VR14	2VR14A	2VR15	2VR16	2VR17	2VR18
	1 1201			OWN PRE	-	-	-	-	-	-	-
B-J	V2 21201-001-4	ISI/PT/	ISI-21201-001	ISI	-	-	-	-	-	s	-
B9.32 1	21201-001-4 1201		29" PIPE TO 2.5" BRANCH CONNECTION	AUG OWN PRE	-	-	-	-	-	-	-
B-J	V2 21201-002-4	ISI/PT/	ISI-21201-002	ISI	-	-	-	-	-	s	-
B9.32 1	21201-002-4 1201		29" PIPE TO 2.5" BRANCH CONNECTION	AUG OWN PRE	-	-	-	-	-	-	-
B-J	V2 21201-003-4		ISI-21201-003	ISI	-	-	-	-	-	-	-
B9.32 1	21201-003-4 1201		29" PIPE TO 2.5" BRANCH CONNECTION	AUG OWN PRE	-	-	-	-	-	-	-
B-J	V2 21201-004-5		ISI-21201-004	ISI	-	-	-	-	-	-	-
B9.32 1	21201-004-5 1201		29" PIPE TO 2.5" BRANCH CONNECTION	AUG OWN PRE	-	-	-	-	-	-	-
B-J	V2 21201-005-5		ISI-21201-005	ISI	-	-	-	-	-	-	-
B9.32 1	21201-005-5 1201		31" PIPE TO 3" BRANCH CONNECTION	AUG OWN PRE	-	-	-	-	-	-	-
B-J	V2 21201-005-6		ISI-21201-005	ISI	-	-	-	-	-	-	-
B9.32 1	21201-005-6 1201		31" PIPE TO 2" BRANCH CONNECTION	AUG OWN PRE	-	-	-	-	-	-	-
B-J	V2 21201-006-5	ISI/PT/	ISI-21201-006	ISI	-	-	-	-	-	s	-
B9.32 1	21201-006-5 1201		31" PIPE TO 3" BRANCH CONNECTION	AUG OWN PRE	-	-	-	-	-	-	-
B-J	V2 21201-006-6	ISI/PT/	ISI-21201-006	ISI	-	-	-	-	-	-	s
B9.32 1	21201-006-6 1201		31" PIPE TO 2" BRANCH CONNECTION	AUG OWN PRE	-	-	-	-	-	-	-
B-J	V2 21201-007-5	ISI/PT/	ISI-21201-007	ISI	-	-	-	-	-	-	s
B9.32	21201-007-5		31" PIPE TO 3" BRANCH CONNECTION	AUG	-	-	-	-	-	-	-

Southern Nuclear Operating Company
3rd Interval
VOGTLE-2 ISI PLAN, VERSION 3.0

Category, Item No., Class	Summary No./CompID/System	Scope / Method / Procedure	Dwg/ISO No. Comp. Desc. Code Case	Period 1		Period 2		Period 3	
				2VR13	2VR14	2VR14A	2VR15	2VR16	2VR17
	1 1201			OWN	-	-	-	-	-
				PRE	-	-	-	-	-
B-J	V2 21201-007-6	ISI/PT/	ISI-21201-007	ISI	-	-	-	-	-
B9.32	21201-007-6		31" PIPE TO 2" BRANCH CONNECTION	AUG	-	-	-	-	-
1	1201			OWN	-	-	-	-	-
				PRE	-	-	-	-	-
B-J	V2 21201-008-5		ISI-21201-008	ISI	-	-	-	-	-
B9.32	21201-008-5		31" PIPE TO 3" BRANCH CONNECTION	AUG	-	-	-	-	-
1	1201			OWN	-	-	-	-	-
				PRE	-	-	-	-	-
B-J	V2 21201-008-6		ISI-21201-008	ISI	-	-	-	-	-
B9.32	21201-008-6		31" PIPE TO 2" BRANCH CONNECTION	AUG	-	-	-	-	-
1	1201			OWN	-	-	-	-	-
				PRE	-	-	-	-	-
B-J	V2 21201-009-2		ISI-21201-009	ISI	-	-	-	-	-
B9.32	21201-009-2		27.5" PIPE TO 2" BRANCH CONNECTION	AUG	-	-	-	-	-
1	1201			OWN	-	-	-	-	-
				PRE	-	-	-	-	-
B-J	V2 21201-009-3		ISI-21201-009	ISI	-	-	-	-	-
B9.32	21201-009-3		27.5" PIPE TO 2.5" BRANCH CONNECTION	AUG	-	-	-	-	-
1	1201			OWN	-	-	-	-	-
				PRE	-	-	-	-	-
B-J	V2 21201-009-5		ISI-21201-009	ISI	-	-	-	-	-
B9.32	21201-009-5		27.5" PIPE TO 3" BRANCH CONNECTION	AUG	-	-	-	-	-
1	1201			OWN	-	-	-	-	-
				PRE	-	-	-	-	-
B-J	V2 21201-009-7			ISI	-	-	-	-	-
B9.32	21201-009-7		27.5" PIPE TO 3" BRANCH CONNECTION	AUG	-	-	-	-	-
1	1201			OWN	-	-	-	-	-
				PRE	-	-	-	-	-
B-J	V2 21201-010-2		ISI-21201-010	ISI	-	-	-	-	-
B9.32	21201-010-2		27.5" PIPE TO 2" BRANCH CONNECTION	AUG	-	-	-	-	-
1	1201			OWN	-	-	-	-	-
				PRE	-	-	-	-	-
B-J	V2 21201-010-3		ISI-21201-010	ISI	-	-	-	-	-

Southern Nuclear Operating Company
3rd Interval
VOGTLE-2 ISI PLAN, VERSION 3.0

Category, Item No., Class	Summary No./CompID/System	Scope / Method / Procedure	Dwg/ISO No. Comp. Desc. Code Case		Period 1		Period 2		Period 3			
					2VR13	2VR14	2VR14A	2VR15	2VR16	2VR17	2VR18	
B9.32 1	21201-010-3 1201		27.5" PIPE TO 2.5" BRANCH CONNECTION	AUG OWN PRE	-	-	-	-	-	-	-	-
B-J	V2 21201-010-5		ISI-21201-010	ISI	-	-	-	-	-	-	-	-
B9.32 1	21201-010-5 1201		27.5" PIPE TO 3" BRANCH CONNECTION	AUG OWN PRE	-	-	-	-	-	-	-	-
B-J	V2 21201-011-2		ISI-21201-011	ISI	-	-	-	-	-	-	-	-
B9.32 1	21201-011-2 1201		27.5" PIPE TO 2" BRANCH CONNECTION	AUG OWN PRE	-	-	-	-	-	-	-	-
B-J	V2 21201-011-3		ISI-21201-011	ISI	-	-	-	-	-	-	-	-
B9.32 1	21201-011-3 1201		27.5" PIPE TO 2.5" BRANCH CONNECTION	AUG OWN PRE	-	-	-	-	-	-	-	-
B-J	V2 21201-011-4		ISI-21201-011	ISI	-	-	-	-	-	-	-	-
B9.32 1	21201-011-4 1201		27.5" PIPE TO 3" BRANCH CONNECTION	AUG OWN PRE	-	-	-	-	-	-	-	-
B-J	V2 21201-011-6		ISI-21201-011	ISI	-	-	-	-	-	-	-	-
B9.32 1	21201-011-6 1201		27.5" PIPE TO 3" BRANCH CONNECTION	AUG OWN PRE	-	-	-	-	-	-	-	-
B-J	V2 21201-012-2		ISI-21201-012	ISI	-	-	-	-	-	-	-	-
B9.32 1	21201-012-2 1201		27.5" PIPE TO 2" BRANCH CONNECTION	AUG OWN PRE	-	-	-	-	-	-	-	-
B-J	V2 21201-012-3		ISI-21201-012	ISI	-	-	-	-	-	-	-	-
B9.32 1	21201-012-3 1201		27.5" PIPE TO 2.5" BRANCH CONNECTION	AUG OWN PRE	-	-	-	-	-	-	-	-
B-J	V2 21201-012-5		ISI-21201-012	ISI	-	-	-	-	-	-	-	-

Southern Nuclear Operating Company
3rd Interval
VOGTLE-2 ISI PLAN, VERSION 3.0

Category, Item No., Class	Summary No./CompID/System	Scope / Method / Procedure	Dwg/ISO No. Comp. Desc. Code Case		Period 1		Period 2		Period 3	
					2VR13	2VR14	2VR14A	2VR15	2VR16	2VR17
B9.32 1	21201-012-5 1201		27.5" PIPE TO 3" BRANCH CONNECTION	AUG OWN PRE	-	-	-	-	-	-
B-J	V2 21201-012-7		ISI-21201-012	ISI	-	-	-	-	-	-
B9.32 1	21201-012-7 1201		27.5" PIPE TO 3" BRANCH CONNECTION	AUG OWN PRE	-	-	-	-	-	-
B-J	V2 21201-029-10 A		ISI-21201-029	ISI	-	-	-	-	-	-
B9.32 1	21201-029-10 A 1201		4" PIPE TO 1-1/4" BRANCH CONNECTION	AUG OWN PRE	-	-	-	-	-	-
B-J	V2 21201-030-32		ISI-21201-030	ISI	-	-	-	-	-	-
B9.32 1	21201-030-32 1201		6" PIPE TO 2" BRANCH CONNECTION	AUG OWN PRE	-	-	-	-	-	-
B-J	V2 21201-030-9 A		ISI-21201-030	ISI	-	-	-	-	-	-
B9.32 1	21201-030-9 A 1201		4" PIPE TO 1-1/4" BRANCH CONNECTION	AUG OWN PRE	-	-	-	-	-	-
B-J	V2 21201-036-20		ISI-21201-036	ISI	-	-	-	-	-	-
B9.32 1	21201-036-20 1201		12" PIPE TO 2" BRANCH CONNECTION	AUG OWN PRE	-	-	-	-	-	-
B-J	V2 21201-049-18		ISI-21201-049	ISI	-	-	-	-	-	-
B9.32 1	21201-049-18 1201		12" PIPE TO 2" BRANCH CONNECTION	AUG OWN PRE	-	-	-	-	-	-
B-J	V2 21201-049-8		ISI-21201-049	ISI	-	-	-	-	-	-
B9.32 1	21201-049-8 1201		12" PIPE TO 2" BRANCH CONNECTION	AUG OWN PRE	-	-	-	-	-	-
B-J	V2 21204-021-2		ISI-21204-021	ISI	-	-	-	-	-	-
B9.32 1	21204-021-2 1204		8" PIPE TO 2" BRANCH CONNECTION	AUG OWN PRE	-	-	-	-	-	-
B-J	V2 21204-023-2		ISI-21204-023	ISI	-	-	-	-	-	-

Southern Nuclear Operating Company
3rd Interval
VOGTLE-2 ISI PLAN, VERSION 3.0

Category, Item No., Class	Summary No./ComplD/System	Scope / Method / Procedure	Dwg/ISO No. Comp. Desc. Code Case		Period 1		Period 2			Period 3	
					2VR13	2VR14	2VR14A	2VR15	2VR16	2VR17	2VR18
B9.32 1	21204-023-2 1204		8" PIPE TO 2" BRANCH CONNECTION	AUG OWN PRE	-	-	-	-	-	-	-
B-J	V2 21204-042-2		ISI-21204-042 6" PIPE TO 2" BRANCH CONNECTION (AI 87-0131)	ISI AUG OWN PRE	-	-	-	-	-	-	-
B9.32 1	21204-042-2 1204				-	-	-	-	-	-	-
B-J	V2 21204-043-2		ISI-21204-043 6" PIPE TO 2" BRANCH CONNECTION (AI 87-0131)	ISI AUG OWN PRE	-	-	-	-	-	-	-
B9.32 1	21204-043-2 1204				-	-	-	-	-	-	-
B-J	V2 21204-044-2		ISI-21204-044 6" PIPE TO 2" BRANCH CONNECTION (AI 87-0131)	ISI AUG OWN PRE	-	-	-	-	-	-	-
B9.32 1	21204-044-2 1204				-	-	-	-	-	-	-
B-J	V2 21204-045-2		ISI-21204-045 6" PIPE TO 2" BRANCH CONNECTION (AI 87-0131)	ISI AUG OWN PRE	-	-	-	-	-	-	-
B9.32 1	21204-045-2 1204				-	-	-	-	-	-	-
B-J	V2 21204-076-12		ISI-21204-076 3" PIPE TO 1.5" BRANCH CONNECTION	ISI AUG OWN PRE	-	-	-	-	-	-	-
B9.32 1	21204-076-12 1204				-	-	-	-	-	-	-
B-J	V2 21204-076-15		ISI-21204-076 3" PIPE TO 1.5" BRANCH CONNECTION	ISI AUG OWN PRE	-	-	-	-	-	-	-
B9.32 1	21204-076-15 1204				-	-	-	-	-	-	-
B-J	V2 21204-076-32		ISI-21204-076 3" PIPE TO 1 1/2" BRANCH CONNECTION	ISI AUG OWN PRE	-	-	-	-	-	-	-
B9.32 1	21204-076-32 1204				-	-	-	-	-	-	-
B-J	V2 21201-009-10		ISI-21201-009 2" BRANCH CONNECTION TO THERMOWELL	ISI AUG OWN	-	-	-	-	-	-	-
B9.40 1	21201-009-10 1201				-	-	-	-	-	-	-

**Southern Nuclear Operating Company
3rd Interval
VOGTLE-2 ISI PLAN, VERSION 3.0**

Category, Item No., Class	Summary No./ComplD/System	Scope / Method / Procedure	Dwg/ISO No. Comp. Desc. Code Case		Period 1		Period 2			Period 3	
					2VR13	2VR14	2VR14A	2VR15	2VR16	2VR17	2VR18
				PRE	-	-	-	-	-	-	-
B-J	V2 21201-010-8		ISI-21201-010	ISI	-	-	-	-	-	-	-
B9.40	21201-010-8		2" BRANCH CONNECTION TO	AUG	-	-	-	-	-	-	-
1	1201		THERMOWELL	OWN	-	-	-	-	-	-	-
				PRE	-	-	-	-	-	-	-
B-J	V2 21201-011-9		ISI-21201-011	ISI	-	-	-	-	-	-	-
B9.40	21201-011-9		2" BRANCH CONNECTION TO	AUG	-	-	-	-	-	-	-
1	1201		THERMOWELL	OWN	-	-	-	-	-	-	-
				PRE	-	-	-	-	-	-	-
B-J	V2 21201-012-10		ISI-21201-012	ISI	-	-	-	-	-	-	-
B9.40	21201-012-10		2" BRANCH CONNECTION TO	AUG	-	-	-	-	-	-	-
1	1201		THERMOWELL	OWN	-	-	-	-	-	-	-
				PRE	-	-	-	-	-	-	-
B-J	V2 21201-029-10 B		ISI-21201-029	ISI	-	-	-	-	-	-	-
B9.40	21201-029-10 B		1.25" BRANCH CONNECTION TO PLUG	AUG	-	-	-	-	-	-	-
1	1201			OWN	-	-	-	-	-	-	-
				PRE	-	-	-	-	-	-	-
B-J	V2 21201-030-9 B		ISI-21201-030	ISI	-	-	-	-	-	-	-
B9.40	21201-030-9 B		1.25" BRANCH CONNECTION TO PLUG	AUG	-	-	-	-	-	-	-
1	1201			OWN	-	-	-	-	-	-	-
				PRE	-	-	-	-	-	-	-
B-J	V2 21201-031-1	ISI/PT/	ISI-21201-031	ISI	-	-	-	-	-	s	-
B9.40	21201-031-1		2" BRANCH CONNECTION TO PIPE	AUG	-	-	-	-	-	-	-
1	1201			OWN	-	-	-	-	-	-	-
				PRE	-	-	-	-	-	-	-
B-J	V2 21201-031-4		ISI-21201-031	ISI	-	-	-	-	-	-	-
B9.40	21201-031-4		2" PIPE TO VALVE	AUG	-	-	-	-	-	-	-
1	1201			OWN	-	-	-	-	-	-	-
				PRE	-	-	-	-	-	-	-
B-J	V2 21201-031-5		ISI-21201-031	ISI	-	-	-	-	-	-	-
B9.40	21201-031-5		2" VALVE TO PIPE	AUG	-	-	-	-	-	-	-
1	1201			OWN	-	-	-	-	-	-	-
				PRE	-	-	-	-	-	-	-
B-J	V2 21201-031-8		ISI-21201-031	ISI	-	-	-	-	-	-	-
B9.40	21201-031-8		2" PIPE TO VALVE	AUG	-	-	-	-	-	-	-
1	1201			OWN	-	-	-	-	-	-	-
				PRE	-	-	-	-	-	-	-

Southern Nuclear Operating Company
3rd Interval
VOGTLE-2 ISI PLAN, VERSION 3.0

Category, Item No., Class	Summary No./ComplD/System	Scope / Method / Procedure	Dwg/ISO No. Comp. Desc. Code Case		Period 1		Period 2			Period 3			
					2VR13	2VR14	2VR14A	2VR15	2VR16	2VR17	2VR18		
B-J B9.40 1	V2 21201-042-1 21201-042-1 1201	ISI/PT/	ISI-21201-042 2" BRANCH CONNECTION TO PIPE	ISI AUG OWN PRE	-	-	-	-	-	-	s	-	-
B-J B9.40 1	V2 21201-042-4 21201-042-4 1201		ISI-21201-042 2" PIPE TO VALVE	ISI AUG OWN PRE	-	-	-	-	-	-	-	-	-
B-J B9.40 1	V2 21201-042-5 21201-042-5 1201		ISI-21201-042 2" VALVE TO PIPE	ISI AUG OWN PRE	-	-	-	-	-	-	-	-	-
B-J B9.40 1	V2 21201-042-6 21201-042-6 1201		ISI-21201-042 2" PIPE TO VALVE	ISI AUG OWN PRE	-	-	-	-	-	-	-	-	-
B-J B9.40 1	V2 21201-046-1 21201-046-1 1201	ISI/PT/	ISI-21201-046 2" BRANCH CONNECTION TO PIPE	ISI AUG OWN PRE	-	-	-	-	-	-	s	-	-
B-J B9.40 1	V2 21201-046-4 21201-046-4 1201		ISI-21201-046 2" PIPE TO VALVE	ISI AUG OWN PRE	-	-	-	-	-	-	-	-	-
B-J B9.40 1	V2 21201-046-5 21201-046-5 1201		ISI-21201-046 2" VALVE TO PIPE	ISI AUG OWN PRE	-	-	-	-	-	-	-	-	-
B-J B9.40 1	V2 21201-046-6 21201-046-6 1201		ISI-21201-046 2" PIPE TO VALVE	ISI AUG OWN PRE	-	-	-	-	-	-	-	-	-
B-J B9.40 1	V2 21201-050-2 21201-050-2 1201	ISI/PT/	ISI-21201-050 2" PIPE TO VALVE	ISI AUG OWN PRE	-	-	-	-	s	-	-	-	-
B-J B9.40 1	V2 21201-050-3 21201-050-3 1201	ISI/PT/	ISI-21201-050 2" VALVE TO PIPE	ISI AUG OWN PRE	-	-	-	-	s	-	-	-	-

**Southern Nuclear Operating Company
3rd Interval
VOGTLE-2 ISI PLAN, VERSION 3.0**

Category, Item No., Class	Summary No./CompID/System	Scope / Method / Procedure	Dwg/ISO No. Comp. Desc. Code Case		Period 1		Period 2		Period 3		
					2VR13	2VR14	2VR14A	2VR15	2VR16	2VR17	2VR18
B-J B9.40 1	V2 21201-050-4 21201-050-4 1201		ISI-21201-050 2" PIPE TO VALVE	ISI AUG OWN PRE	-	-	-	-	-	-	-
B-J B9.40 1	V2 21201-051-1 21201-051-1 1201	ISI/PT/	ISI-21201-051 2" BRANCH CONNECTION TO PIPE	ISI AUG OWN PRE	-	-	-	-	-	s	-
B-J B9.40 1	V2 21201-051-6 21201-051-6 1201		ISI-21201-051 2" PIPE TO VALVE	ISI AUG OWN PRE	-	-	-	-	-	-	-
B-J B9.40 1	V2 21201-051-7 21201-051-7 1201		ISI-21201-051 2" VALVE TO PIPE	ISI AUG OWN PRE	-	-	-	-	-	-	-
B-J B9.40 1	V2 21201-051-8 21201-051-8 1201		ISI-21201-051 2" PIPE TO VALVE	ISI AUG OWN PRE	-	-	-	-	-	-	-
B-J B9.40 1	V2 21201-208-2 21201-208-2 1201		ISI-21201-208 2" PIPE TO VALVE	ISI AUG OWN PRE	-	-	-	-	-	-	-
B-J B9.40 1	V2 21201-208-3 21201-208-3 1201		ISI-21201-208 2" VALVE TO PIPE	ISI AUG OWN PRE	-	-	-	-	-	-	-
B-J B9.40 1	V2 21201-208-4 21201-208-4 1201		ISI-21201-208 2" PIPE TO VALVE	ISI AUG OWN PRE	-	-	-	-	-	-	-
B-J B9.40 1	V2 21204-018-1 21204-018-1 1204	ISI/PT/	ISI-21204-018 2" VALVE TO PIPE	ISI AUG OWN PRE	-	-	-	-	-	s	-
B-J B9.40 1	V2 21204-022-1R 21204-022-1R 1204		ISI-21204-022 2" VALVE TO PIPE	ISI AUG OWN PRE	-	-	-	-	-	-	-

Southern Nuclear Operating Company
3rd Interval
VOGTLE-2 ISI PLAN, VERSION 3.0

Category, Item No., Class	Summary No./CompID/System	Scope / Method / Procedure	Dwg/ISO No. Comp. Desc. Code Case		Period 1		Period 2		Period 3	
					2VR13	2VR14	2VR14A	2VR15	2VR16	2VR17
B-J	V2 21204-024-1		ISI-21204-024	ISI	-	-	-	-	-	-
B9.40	21204-024-1		2" VALVE TO PIPE	AUG	-	-	-	-	-	-
1	1204			OWN	-	-	-	-	-	-
				PRE	-	-	-	-	-	-
B-J	V2 21204-025-1		ISI-21204-025	ISI	-	-	-	-	-	-
B9.40	21204-025-1		2" VALVE TO PIPE	AUG	-	-	-	-	-	-
1	1204			OWN	-	-	-	-	-	-
				PRE	-	-	-	-	-	-
B-J	V2 21204-033-1		ISI-21204-033	ISI	-	-	-	-	-	-
B9.40	21204-033-1		2" VALVE TO PIPE	AUG	-	-	-	-	-	-
1	1204			OWN	-	-	-	-	-	-
				PRE	-	-	-	-	-	-
B-J	V2 21204-034-1	ISI/PT/	ISI-21204-034	ISI	-	-	-	-	-	s
B9.40	21204-034-1		2" VALVE TO PIPE	AUG	-	-	-	-	-	-
1	1204			OWN	-	-	-	-	-	-
				PRE	-	-	-	-	-	-
B-J	V2 21204-035-1		ISI-21204-035	ISI	-	-	-	-	-	-
B9.40	21204-035-1		2" VALVE TO PIPE	AUG	-	-	-	-	-	-
1	1204			OWN	-	-	-	-	-	-
				PRE	-	-	-	-	-	-
B-J	V2 21204-036-1		ISI-21204-036	ISI	-	-	-	-	-	-
B9.40	21204-036-1		2" VALVE TO PIPE	AUG	-	-	-	-	-	-
1	1204			OWN	-	-	-	-	-	-
				PRE	-	-	-	-	-	-
B-J	V2 21204-076-45		ISI-21204-076	ISI	-	-	-	-	-	-
B9.40	21204-076-45		1.5" PIPE TO VALVE	AUG	-	-	-	-	-	-
1	1204			OWN	-	-	-	-	-	-
				PRE	-	-	-	-	-	-
B-J	V2 21204-077-12		ISI-21204-077	ISI	-	-	-	-	-	-
B9.40	21204-077-12		1.5" PIPE TO VALVE	AUG	-	-	-	-	-	-
1	1204			OWN	-	-	-	-	-	-
				PRE	-	-	-	-	-	-
B-J	V2 21204-078-12		ISI-21204-078	ISI	-	-	-	-	-	-
B9.40	21204-078-12		1.5" PIPE TO VALVE	AUG	-	-	-	-	-	-
1	1204			OWN	-	-	-	-	-	-
				PRE	-	-	-	-	-	-
B-J	V2 21204-079-13		ISI-21204-079	ISI	-	-	-	-	-	-
B9.40	21204-079-13		1.5" PIPE TO VALVE	AUG	-	-	-	-	-	-
1	1204			OWN	-	-	-	-	-	-
				PRE	-	-	-	-	-	-

Southern Nuclear Operating Company 3rd Interval VOGTLE-2 ISI PLAN, VERSION 3.0

Category, Item No., Class	Summary No./ComplID/System	Scope / Method / Procedure	Dwg/ISO No. Comp. Desc. Code Case		Period 1		Period 2		Period 3	
					2VR13	2VR14	2VR14A	2VR15	2VR16	2VR17
B-J B9.40 1	V2 21204-243-1 21204-243-1 1204		ISI-21204-243 1.5" VALVE TO PIPE	ISI AUG OWN PRE	-	-	-	-	-	-
B-J B9.40 1	V2 21204-243-29 21204-243-29 1204	ISI/PT/	ISI-21204-243 1.5" PIPE TO VALVE	ISI AUG OWN PRE	-	-	s	-	-	-
B-J B9.40 1	V2 21204-243-30 21204-243-30 1204		ISI-21204-243 1.5" VALVE TO PIPE	ISI AUG OWN PRE	-	-	-	-	-	-
B-J B9.40 1	V2 21204-244-1 21204-244-1 1204		ISI-21204-244 1.5" VALVE TO PIPE	ISI AUG OWN PRE	-	-	-	-	-	-
B-J B9.40 1	V2 21204-244-27 21204-244-27 1204		ISI-21204-244 1.5" PIPE TO VALVE	ISI AUG OWN PRE	-	-	-	-	-	-
B-J B9.40 1	V2 21204-244-28 21204-244-28 1204		ISI-21204-244 1.5" VALVE TO PIPE	ISI AUG OWN PRE	-	-	-	-	-	-
B-J B9.40 1	V2 21204-245-1 21204-245-1 1204		ISI-21204-245 1.5" VALVE TO PIPE	ISI AUG OWN PRE	-	-	-	-	-	-
B-J B9.40 1	V2 21204-245-29 21204-245-29 1204		ISI-21204-245 1.5" PIPE TO VALVE	ISI AUG OWN PRE	-	-	-	-	-	-
B-J B9.40 1	V2 21204-245-30 21204-245-30 1204	ISI/PT/	ISI-21204-245 1.5" VALVE TO PIPE	ISI AUG OWN PRE	-	-	-	-	s	-
B-J B9.40 1	V2 21204-246-1 21204-246-1 1204		ISI-21204-246 1.5" VALVE TO PIPE	ISI AUG OWN PRE	-	-	-	-	-	-

**Southern Nuclear Operating Company
3rd Interval
VOGTLE-2 ISI PLAN, VERSION 3.0**

Category, Item No., Class	Summary No./ComplD/System	Scope / Method / Procedure	Dwg/ISO No. Comp. Desc. Code Case		Period 1		Period 2			Period 3	
					2VR13	2VR14	2VR14A	2VR15	2VR16	2VR17	2VR18
B-J B9.40 1	V2 21204-246-31 21204-246-31 1204		ISI-21204-246 1.5" PIPE TO VALVE	ISI AUG OWN PRE	- - - -	- - - -	- - - -	- - - -	- - - -	- - - -	- - - -
B-J B9.40 1	V2 21204-246-32 21204-246-32 1204	ISI/PT/	ISI-21204-246 1.5" VALVE TO PIPE	ISI AUG OWN PRE	- - - -	- - - -	- - - -	s - - -	- - - -	- - - -	- - - -
B-J B9.40 1	V2 21208-012-1 21208-012-1 1208		ISI-21208-012 2" VALVE TO PIPE	ISI AUG OWN PRE	- - - -	- - - -	- - - -	- - - -	- - - -	- - - -	- - - -
B-J B9.40 1	V2 21208-012-2 21208-012-2 1208		ISI-21208-012 2" PIPE TO VALVE	ISI AUG OWN PRE	- - - -	- - - -	- - - -	- - - -	- - - -	- - - -	- - - -
B-J B9.40 1	V2 21208-012-3 21208-012-3 1208		ISI-21208-012 2" VALVE TO PIPE	ISI AUG OWN PRE	- - - -	- - - -	- - - -	- - - -	- - - -	- - - -	- - - -
B-J B9.40 1	V2 21208-012-6 21208-012-6 1208		ISI-21208-012 2" PIPE TO VALVE	ISI AUG OWN PRE	- - - -	- - - -	- - - -	- - - -	- - - -	- - - -	- - - -
B-J B9.40 1	V2 21208-012-7 21208-012-7 1208		ISI-21208-012 2" VALVE TO PIPE	ISI AUG OWN PRE	- - - -	- - - -	- - - -	- - - -	- - - -	- - - -	- - - -
B-J B9.40 1	V2 21208-012-8 21208-012-8 1208		ISI-21208-012 2" PIPE TO ELBOW	ISI AUG OWN PRE	- - - -	- - - -	- - - -	- - - -	- - - -	- - - -	- - - -
B-J B9.40 1	V2 21208-012-9 21208-012-9 1208		ISI-21208-012 2" ELBOW TO PIPE	ISI AUG OWN PRE	- - - -	- - - -	- - - -	- - - -	- - - -	- - - -	- - - -
B-J B9.40 1	V2 21208-024-1 21208-024-1 1208		ISI-21208-024 1.5" VALVE TO PIPE	ISI AUG OWN PRE	- - - -	- - - -	- - - -	- - - -	- - - -	- - - -	- - - -

**Southern Nuclear Operating Company
3rd Interval
VOGTLE-2 ISI PLAN, VERSION 3.0**

Category, Item No., Class	Summary No./CompID/System	Scope / Method / Procedure	Dwg/ISO No. Comp. Desc. Code Case		Period 1		Period 2		Period 3		
					2VR13	2VR14	2VR14A	2VR15	2VR16	2VR17	2VR18
B-J B9.40 1	V2 21208-024-12 B 21208-024-12 B 1208	ISI/PT/	ISI-21208-024 1.5" PIPE TO PUMP PENETRATION	ISI AUG OWN PRE	-	-	-	-	-	s	-
B-J B9.40 1	V2 21208-024-2 21208-024-2 1208		ISI-21208-024 1.5" PIPE TO VALVE	ISI AUG OWN PRE	-	-	-	-	-	-	-
B-J B9.40 1	V2 21208-024-3 21208-024-3 1208		ISI-21208-024 1.5" VALVE TO PIPE	ISI AUG OWN PRE	-	-	-	-	-	-	-
B-J B9.40 1	V2 21208-043-1 21208-043-1 1208		ISI-21208-043 1.5" VALVE TO PIPE	ISI AUG OWN PRE	-	-	-	-	-	-	-
B-J B9.40 1	V2 21208-043-16 B 21208-043-16 B 1208	ISI/PT/	ISI-21208-043 1.5" PIPE TO PUMP PENETRATION	ISI AUG OWN PRE	-	-	-	-	-	s	-
B-J B9.40 1	V2 21208-043-2 21208-043-2 1208		ISI-21208-043 1.5" PIPE TO VALVE	ISI AUG OWN PRE	-	-	-	-	-	-	-
B-J B9.40 1	V2 21208-043-3 21208-043-3 1208		ISI-21208-043 1.5" VALVE TO PIPE	ISI AUG OWN PRE	-	-	-	-	-	-	-
B-J B9.40 1	V2 21208-045-1 21208-045-1 1208		ISI-21208-045 1.5" VALVE TO PIPE	ISI AUG OWN PRE	-	-	-	-	-	-	-
B-J B9.40 1	V2 21208-045-2 21208-045-2 1208		ISI-21208-045 1.5" PIPE TO VALVE	ISI AUG OWN PRE	-	-	-	-	-	-	-
B-J B9.40 1	V2 21208-045-20 B 21208-045-20 B 1208	ISI/PT/	ISI-21208-045 1.5" PIPE TO PUMP PENETRATION	ISI AUG OWN PRE	-	-	-	-	-	s	-

Southern Nuclear Operating Company
3rd Interval
VOGTLE-2 ISI PLAN, VERSION 3.0

Category, Item No., Class	Summary No./CompID/System	Scope / Method / Procedure	Dwg/ISO No. Comp. Desc. Code Case		Period 1		Period 2		Period 3	
					2VR13	2VR14	2VR14A	2VR15	2VR16	2VR17
B-J	V2 21208-045-3		ISI-21208-045	ISI	-	-	-	-	-	-
B9.40	21208-045-3		1.5" VALVE TO PIPE	AUG	-	-	-	-	-	-
1	1208			OWN	-	-	-	-	-	-
				PRE	-	-	-	-	-	-
B-J	V2 21208-047-1		ISI-21208-047	ISI	-	-	-	-	-	-
B9.40	21208-047-1		1.5" VALVE TO PIPE	AUG	-	-	-	-	-	-
1	1208			OWN	-	-	-	-	-	-
				PRE	-	-	-	-	-	-
B-J	V2 21208-047-18 B	ISI/PT/	ISI-21208-047	ISI	-	-	-	-	-	s
B9.40	21208-047-18 B		1.5" PIPE TO PUMP PENETRATION	AUG	-	-	-	-	-	-
1	1208			OWN	-	-	-	-	-	-
				PRE	-	-	-	-	-	-
B-J	V2 21208-047-2		ISI-21208-047	ISI	-	-	-	-	-	-
B9.40	21208-047-2		1.5" PIPE TO VALVE	AUG	-	-	-	-	-	-
1	1208			OWN	-	-	-	-	-	-
				PRE	-	-	-	-	-	-
B-J	V2 21208-047-3		ISI-21208-047	ISI	-	-	-	-	-	-
B9.40	21208-047-3		1.5" VALVE TO PIPE	AUG	-	-	-	-	-	-
1	1208			OWN	-	-	-	-	-	-
				PRE	-	-	-	-	-	-

Vogtle Nuclear Plant
Code Compliance Scheduling Summary - 3rd Interval
ISI - Code Edition - 2001 Edition with 2003 Addenda

Cat.	Item No.	Code Case	Population	Percent Required	Actual Required	Round Up	Total Exams	Period 1			Period 2			Period 3		
								Count	Actual Period	Round Up	Count	Actual Period	Round Up	Count	Actual Period	Round Up
C-F-1	C5.11		1157	7.50%	86.78	87	90	20	23.05%	23%	34	62.23%	63%	36	103.71%	104%
C-F-1	C5.21		297	7.50%	22.28	23	20	0	0%	0%	10	44.88%	44%	10	89.77%	87%
C-F-1	C5.30		1	7.50%	0.08	1	1	0	0%	0%	1	1250.00%	100%	0	1250.00%	100%
C-F-1	C5.41		19	7.50%	1.43	2	3	0	0%	0%	0	0.00%	0%	3	209.79%	150%
Total:			1474		110	113	114	20	18.10%	18%	45	59.00%	58%	49	103.00%	100%

Southern Nuclear Operating Company
3rd Interval
VOGTLE-2 ISI PLAN, VERSION 3.0

Category, Item No., Class	Summary No./ComplD/System	Scope / Method / Procedure	Dwg/ISO No. Comp. Desc. Code Case		Period 1		Period 2			Period 3	
					2VR13	2VR14	2VR14A	2VR15	2VR16	2VR17	2VR18
C-F-1 C5.11 2	V2 21204-001-1 21204-001-1 1204	ISI/UT/	ISI-21204-001 12" BRANCH CONNECTION TO PIPE	ISI AUG OWN PRE	-	-	-	s	-	-	-
C-F-1 C5.11 2	V2 21204-001-1 A 21204-001-1 A 1204		ISI-21204-001 12" PIPE TO FLANGE	ISI AUG OWN PRE	-	-	-	-	-	-	-
C-F-1 C5.11 2	V2 21204-001-1 B 21204-001-1 B 1204		ISI-21204-001 12" FLANGE TO PIPE	ISI AUG OWN PRE	-	-	-	-	-	-	-
C-F-1 C5.11 2	V2 21204-001-1 C 21204-001-1 C 1204		ISI-21204-001 12" PIPE TO FLANGE	ISI AUG OWN PRE	-	-	-	-	-	-	-
C-F-1 C5.11 2	V2 21204-001-1 D 21204-001-1 D 1204		ISI-21204-001 12" FLANGE TO PIPE	ISI AUG OWN PRE	-	-	-	-	-	-	-
C-F-1 C5.11 2	V2 21204-001-2 21204-001-2 1204		ISI-21204-001 12" PIPE TO ELBOW	ISI AUG OWN PRE	-	-	-	-	-	-	-
C-F-1 C5.11 2	V2 21204-001-3 21204-001-3 1204		ISI-21204-001 12" ELBOW TO PIPE	ISI AUG OWN PRE	-	-	-	-	-	-	-
C-F-1 C5.11 2	V2 21204-001-4 21204-001-4 1204		ISI-21204-001 12" PIPE TO ELBOW	ISI AUG OWN PRE	-	-	-	-	-	-	-
C-F-1 C5.11 2	V2 21204-001-5 21204-001-5 1204		ISI-21204-001 12" ELBOW TO PIPE	ISI AUG OWN PRE	-	-	-	-	-	-	-
C-F-1 C5.11 2	V2 21204-001-7 21204-001-7 1204		ISI-21204-001 12" PIPE TO ELBOW	ISI AUG OWN PRE	-	-	-	-	-	-	-

Southern Nuclear Operating Company

3rd Interval

VOGTLE-2 ISI PLAN, VERSION 3.0

Category, Item No., Class	Summary No./CompID/System	Scope / Method / Procedure	Dwg/ISO No. Comp. Desc. Code Case		Period 1		Period 2			Period 3	
					2VR13	2VR14	2VR14A	2VR15	2VR16	2VR17	2VR18
C-F-1 C5.11 2	V2 21204-001-8 21204-001-8 1204		ISI-21204-001 12" ELBOW TO PIPE	ISI AUG OWN PRE	-	-	-	-	-	-	-
C-F-1 C5.11 2	V2 21204-001-9 21204-001-9 1204		ISI-21204-001 12" PIPE TO VALVE	ISI AUG OWN PRE	-	-	-	-	-	-	-
C-F-1 C5.11 2	V2 21204-006-1 21204-006-1 1204	ISI/UT/	ISI-21204-006 24" NOZZLE TO VALVE (AI 87-0131)	ISI AUG OWN PRE	-	-	-	5	-	-	-
C-F-1 C5.11 2	V2 21204-006-11 21204-006-11 1204		ISI-21204-006 24" PIPE TO PIPE	ISI AUG OWN PRE	-	-	-	-	-	-	-
C-F-1 C5.11 2	V2 21204-006-12 21204-006-12 1204		ISI-21204-006 24" PIPE TO ELBOW	ISI AUG OWN PRE	-	-	-	-	-	-	-
C-F-1 C5.11 2	V2 21204-006-13 21204-006-13 1204		ISI-21204-006 24" ELBOW TO PIPE	ISI AUG OWN PRE	-	-	-	-	-	-	-
C-F-1 C5.11 2	V2 21204-006-13 A 21204-006-13 A 1204		ISI-21204-006 24" PIPE TO TEE	ISI AUG OWN PRE	-	-	-	-	-	-	-
C-F-1 C5.11 2	V2 21204-006-13 B 21204-006-13 B 1204		ISI-21204-006 24" TEE TO FLANGE	ISI AUG OWN PRE	-	-	-	-	-	-	-
C-F-1 C5.11 2	V2 21204-006-14 21204-006-14 1204		ISI-21204-006 24" TEE TO PIPE	ISI AUG OWN PRE	-	-	-	-	-	-	-
C-F-1 C5.11 2	V2 21204-006-15 21204-006-15 1204		ISI-21204-006 24" PIPE TO ELBOW	ISI AUG OWN PRE	-	-	-	-	-	-	-

Southern Nuclear Operating Company
3rd Interval
VOGTLE-2 ISI PLAN, VERSION 3.0

Category, Item No., Class	Summary No./ComplD/System	Scope / Method / Procedure	Dwg/ISO No. Comp. Desc. Code Case		Period 1		Period 2		Period 3	
					2VR13	2VR14	2VR14A	2VR15	2VR16	2VR17
C-F-1	V2 21204-006-16		ISI-21204-006	ISI	-	-	-	-	-	-
C5.11	21204-006-16		24" ELBOW TO PIPE	AUG	-	-	-	-	-	-
2	1204			OWN	-	-	-	-	-	-
				PRE	-	-	-	-	-	-
C-F-1	V2 21204-006-17		ISI-21204-006	ISI	-	-	-	-	-	-
C5.11	21204-006-17		24" PIPE TO PIPE	AUG	-	-	-	-	-	-
2	1204			OWN	-	-	-	-	-	-
				PRE	-	-	-	-	-	-
C-F-1	V2 21204-006-2	ISI/UT/	ISI-21204-006	ISI	-	-	-	-	-	s
C5.11	21204-006-2		24" VALVE TO ELBOW (AI 87-0131)	AUG	-	-	-	-	-	-
2	1204			OWN	-	-	-	-	-	-
				PRE	-	-	-	-	-	-
C-F-1	V2 21204-006-21		ISI-21204-006	ISI	-	-	-	-	-	-
C5.11	21204-006-21		24" PIPE TO ELBOW	AUG	-	-	-	-	-	-
2	1204			OWN	-	-	-	-	-	-
				PRE	-	-	-	-	-	-
C-F-1	V2 21204-006-22		ISI-21204-006	ISI	-	-	-	-	-	-
C5.11	21204-006-22		24" ELBOW TO PIPE	AUG	-	-	-	-	-	-
2	1204			OWN	-	-	-	-	-	-
				PRE	-	-	-	-	-	-
C-F-1	V2 21204-006-24		ISI-21204-006	ISI	-	-	-	-	-	-
C5.11	21204-006-24		24" PIPE TO ELBOW	AUG	-	-	-	-	-	-
2	1204			OWN	-	-	-	-	-	-
				PRE	-	-	-	-	-	-
C-F-1	V2 21204-006-25		ISI-21204-006	ISI	-	-	-	-	-	-
C5.11	21204-006-25		24" ELBOW TO PIPE	AUG	-	-	-	-	-	-
2	1204			OWN	-	-	-	-	-	-
				PRE	-	-	-	-	-	-
C-F-1	V2 21204-006-27		ISI-21204-006	ISI	-	-	-	-	-	-
C5.11	21204-006-27		24" PIPE TO PIPE	AUG	-	-	-	-	-	-
2	1204			OWN	-	-	-	-	-	-
				PRE	-	-	-	-	-	-
C-F-1	V2 21204-006-28		ISI-21204-006	ISI	-	-	-	-	-	-
C5.11	21204-006-28		24" PIPE TO PIPE	AUG	-	-	-	-	-	-
2	1204			OWN	-	-	-	-	-	-
				PRE	-	-	-	-	-	-
C-F-1	V2 21204-006-28 A		ISI-21204-006	ISI	-	-	-	-	-	-
C5.11	21204-006-28 A		24" PIPE TO TEE	AUG	-	-	-	-	-	-
2	1204			OWN	-	-	-	-	-	-
				PRE	-	-	-	-	-	-

Southern Nuclear Operating Company
3rd Interval
VOGTLE-2 ISI PLAN, VERSION 3.0

Category, Item No., Class	Summary No./CompID/System	Scope / Method / Procedure	Dwg/ISO No. Comp. Desc. Code Case		Period 1		Period 2			Period 3	
					2VR13	2VR14	2VR14A	2VR15	2VR16	2VR17	2VR18
C-F-1	V2 21204-006-28 B		ISI-21204-006	ISI	-	-	-	-	-	-	-
C5.11	21204-006-28 B		24" TEE TO FLANGE	AUG	-	-	-	-	-	-	-
2	1204			OWN	-	-	-	-	-	-	-
				PRE	-	-	-	-	-	-	-
C-F-1	V2 21204-006-29		ISI-21204-006	ISI	-	-	-	-	-	-	-
C5.11	21204-006-29		24" TEE TO PIPE	AUG	-	-	-	-	-	-	-
2	1204			OWN	-	-	-	-	-	-	-
				PRE	-	-	-	-	-	-	-
C-F-1	V2 21204-006-29 A		ISI-21204-006	ISI	-	-	-	-	-	-	-
C5.11	21204-006-29 A		24" PIPE TO PIPE	AUG	-	-	-	-	-	-	-
2	1204			OWN	-	-	-	-	-	-	-
				PRE	-	-	-	-	-	-	-
C-F-1	V2 21204-006-3		ISI-21204-006	ISI	-	-	-	-	-	-	-
C5.11	21204-006-3		24" ELBOW TO PIPE (AI 87-0131)	AUG	-	-	-	-	-	-	-
2	1204			OWN	-	-	-	-	-	-	-
				PRE	-	-	-	-	-	-	-
C-F-1	V2 21204-006-30		ISI-21204-006	ISI	-	-	-	-	-	-	-
C5.11	21204-006-30		24" PIPE TO ELBOW	AUG	-	-	-	-	-	-	-
2	1204			OWN	-	-	-	-	-	-	-
				PRE	-	-	-	-	-	-	-
C-F-1	V2 21204-006-31		ISI-21204-006	ISI	-	-	-	-	-	-	-
C5.11	21204-006-31		24" ELBOW TO PIPE	AUG	-	-	-	-	-	-	-
2	1204			OWN	-	-	-	-	-	-	-
				PRE	-	-	-	-	-	-	-
C-F-1	V2 21204-006-33	ISI/UT/	ISI-21204-006	ISI	-	-	-	-	-	s	-
C5.11	21204-006-33		24" PIPE TO ELBOW	AUG	-	-	-	-	-	-	-
2	1204			OWN	-	-	-	-	-	-	-
				PRE	-	-	-	-	-	-	-
C-F-1	V2 21204-006-34		ISI-21204-006	ISI	-	-	-	-	-	-	-
C5.11	21204-006-34		24" ELBOW TO PIPE	AUG	-	-	-	-	-	-	-
2	1204			OWN	-	-	-	-	-	-	-
				PRE	-	-	-	-	-	-	-
C-F-1	V2 21204-006-35		ISI-21204-006	ISI	-	-	-	-	-	-	-
C5.11	21204-006-35		24" PIPE TO ELBOW	AUG	-	-	-	-	-	-	-
2	1204			OWN	-	-	-	-	-	-	-
				PRE	-	-	-	-	-	-	-
C-F-1	V2 21204-006-36		ISI-21204-006	ISI	-	-	-	-	-	-	-
C5.11	21204-006-36		24" ELBOW TO PIPE	AUG	-	-	-	-	-	-	-
2	1204			OWN	-	-	-	-	-	-	-
				PRE	-	-	-	-	-	-	-

Southern Nuclear Operating Company
3rd Interval
VOGTLE-2 ISI PLAN, VERSION 3.0

Category, Item No., Class	Summary No./ComplD/System	Scope / Method / Procedure	Dwg/ISO No. Comp. Desc. Code Case		Period 1		Period 2		Period 3	
					2VR13	2VR14	2VR14A	2VR15	2VR16	2VR17
C-F-1 C5.11 2	V2 21204-006-37 21204-006-37 1204		ISI-21204-006 24" PIPE TO ELBOW	ISI AUG OWN PRE	- - - -	- - - -	- - - -	- - - -	- - - -	- - - -
C-F-1 C5.11 2	V2 21204-006-38 21204-006-38 1204		ISI-21204-006 24" ELBOW TO PIPE	ISI AUG OWN PRE	- - - -	- - - -	- - - -	- - - -	- - - -	- - - -
C-F-1 C5.11 2	V2 21204-006-4 21204-006-4 1204		ISI-21204-006 24" PIPE TO ELBOW	ISI AUG OWN PRE	- - - -	- - - -	- - - -	- - - -	- - - -	- - - -
C-F-1 C5.11 2	V2 21204-006-41 21204-006-41 1204		ISI-21204-006 24" PIPE TO PIPE	ISI AUG OWN PRE	- - - -	- - - -	- - - -	- - - -	- - - -	- - - -
C-F-1 C5.11 2	V2 21204-006-43 21204-006-43 1204		ISI-21204-006 24" PIPE TO PIPE	ISI AUG OWN PRE	- - - -	- - - -	- - - -	- - - -	- - - -	- - - -
C-F-1 C5.11 2	V2 21204-006-45 21204-006-45 1204		ISI-21204-006 24" PIPE TO PIPE	ISI AUG OWN PRE	- - - -	- - - -	- - - -	- - - -	- - - -	- - - -
C-F-1 C5.11 2	V2 21204-006-46 21204-006-46 1204		ISI-21204-006 24" PIPE TO PIPE	ISI AUG OWN PRE	- - - -	- - - -	- - - -	- - - -	- - - -	- - - -
C-F-1 C5.11 2	V2 21204-006-48 21204-006-48 1204		ISI-21204-006 24" PIPE TO ELBOW	ISI AUG OWN PRE	- - - -	- - - -	- - - -	- - - -	- - - -	- - - -
C-F-1 C5.11 2	V2 21204-006-49 21204-006-49 1204		ISI-21204-006 24" ELBOW TO PIPE	ISI AUG OWN PRE	- - - -	- - - -	- - - -	- - - -	- - - -	- - - -
C-F-1 C5.11 2	V2 21204-006-49 A 21204-006-49 A 1204		ISI-21204-006 24" PIPE TO FLANGE	ISI AUG OWN PRE	- - - -	- - - -	- - - -	- - - -	- - - -	- - - -

Southern Nuclear Operating Company
3rd Interval
VOGTLE-2 ISI PLAN, VERSION 3.0

Category, Item No., Class	Summary No./ComplD/System	Scope / Method / Procedure	Dwg/ISO No. Comp. Desc. Code Case		Period 1		Period 2		Period 3	
					2VR13	2VR14	2VR14A	2VR15	2VR16	2VR17
C-F-1 C5.11 2	V2 21204-006-49 B 21204-006-49 B 1204		ISI-21204-006 24" FLANGE TO PIPE	ISI AUG OWN PRE	-	-	-	-	-	-
C-F-1 C5.11 2	V2 21204-006-49 C 21204-006-49 C 1204		ISI-21204-006 24" PIPE TO FLANGE	ISI AUG OWN PRE	-	-	-	-	-	-
C-F-1 C5.11 2	V2 21204-006-49 D 21204-006-49 D 1204		ISI-21204-006 24" FLANGE TO PIPE	ISI AUG OWN PRE	-	-	-	-	-	-
C-F-1 C5.11 2	V2 21204-006-5 21204-006-5 1204		ISI-21204-006 24" ELBOW TO ELBOW	ISI AUG OWN PRE	-	-	-	-	-	-
C-F-1 C5.11 2	V2 21204-006-50 21204-006-50 1204		ISI-21204-006 24" PIPE TO ELBOW	ISI AUG OWN PRE	-	-	-	-	-	-
C-F-1 C5.11 2	V2 21204-006-51 21204-006-51 1204		ISI-21204-006 24" ELBOW TO PIPE	ISI AUG OWN PRE	-	-	-	-	-	-
C-F-1 C5.11 2	V2 21204-006-52 21204-006-52 1204		ISI-21204-006 24" PIPE TO ELBOW	ISI AUG OWN PRE	-	-	-	-	-	-
C-F-1 C5.11 2	V2 21204-006-53 21204-006-53 1204		ISI-21204-006 24" ELBOW TO PIPE	ISI AUG OWN PRE	-	-	-	-	-	-
C-F-1 C5.11 2	V2 21204-006-54 21204-006-54 1204	ISI/UT/	ISI-21204-006 24" PIPE TO ELBOW (AI 87-0131)	ISI AUG OWN PRE	-	-	s	-	-	-
C-F-1 C5.11 2	V2 21204-006-55 21204-006-55 1204	ISI/UT/NMP-ES-024-501	ISI-21204-006 24" ELBOW TO PIPE (AI 87-0131)	ISI AUG OWN PRE	s	-	-	-	-	-

Southern Nuclear Operating Company
3rd Interval
VOGTLE-2 ISI PLAN, VERSION 3.0

Category, Item No., Class	Summary No./ComplD/System	Scope / Method / Procedure	Dwg/ISO No. Comp. Desc. Code Case		Period 1		Period 2		Period 3	
					2VR13	2VR14	2VR14A	2VR15	2VR16	2VR17
C-F-1 C5.11 2	V2 21204-006-57 21204-006-57 1204		ISI-21204-006 24" PIPE TO PIPE	ISI AUG OWN PRE	- - - -	- - - -	- - - -	- - - -	- - - -	- - - -
C-F-1 C5.11 2	V2 21204-006-58 21204-006-58 1204		ISI-21204-006 24" PIPE TO PIPE	ISI AUG OWN PRE	- - - -	- - - -	- - - -	- - - -	- - - -	- - - -
C-F-1 C5.11 2	V2 21204-006-59 21204-006-59 1204		ISI-21204-006 24" PIPE TO PIPE	ISI AUG OWN PRE	- - - -	- - - -	- - - -	- - - -	- - - -	- - - -
C-F-1 C5.11 2	V2 21204-006-6 21204-006-6 1204		ISI-21204-006 24" ELBOW TO PIPE	ISI AUG OWN PRE	- - - -	- - - -	- - - -	- - - -	- - - -	- - - -
C-F-1 C5.11 2	V2 21204-006-61 21204-006-61 1204		ISI-21204-006 24" PIPE TO PIPE	ISI AUG OWN PRE	- - - -	- - - -	- - - -	- - - -	- - - -	- - - -
C-F-1 C5.11 2	V2 21204-006-62 21204-006-62 1204		ISI-21204-006 24" PIPE TO PIPE	ISI AUG OWN PRE	- - - -	- - - -	- - - -	- - - -	- - - -	- - - -
C-F-1 C5.11 2	V2 21204-006-64 21204-006-64 1204		ISI-21204-006 24" PIPE TO PIPE	ISI AUG OWN PRE	- - - -	- - - -	- - - -	- - - -	- - - -	- - - -
C-F-1 C5.11 2	V2 21204-006-65 21204-006-65 1204		ISI-21204-006 24" PIPE TO PIPE	ISI AUG OWN PRE	- - - -	- - - -	- - - -	- - - -	- - - -	- - - -
C-F-1 C5.11 2	V2 21204-006-70 21204-006-70 1204		ISI-21204-006 24" PIPE TO FLANGE	ISI AUG OWN PRE	- - - -	- - - -	- - - -	- - - -	- - - -	- - - -
C-F-1 C5.11 2	V2 21204-006-73 21204-006-73 1204		ISI-21204-006 12" BRANCH CONNECTION TO PIPE	ISI AUG OWN PRE	- - - -	- - - -	- - - -	- - - -	- - - -	- - - -

Southern Nuclear Operating Company
3rd Interval
VOGTLE-2 ISI PLAN, VERSION 3.0

Category, Item No., Class	Summary No./CompID/System	Scope / Method / Procedure	Dwg/ISO No. Comp. Desc. Code Case		Period 1		Period 2		Period 3	
					2VR13	2VR14	2VR14A	2VR15	2VR16	2VR17
C-F-1 C5.11 2	V2 21204-006-73 A 21204-006-73 A 1204		ISI-21204-006 12" PIPE TO FLANGE	ISI AUG OWN PRE	- - - -	- - - -	- - - -	- - - -	- - - -	- - - -
C-F-1 C5.11 2	V2 21204-006-73 B 21204-006-73 B 1204		ISI-21204-006 12" FLANGE TO PIPE	ISI AUG OWN PRE	- - - -	- - - -	- - - -	- - - -	- - - -	- - - -
C-F-1 C5.11 2	V2 21204-006-73 C 21204-006-73 C 1204		ISI-21204-006 12" PIPE TO FLANGE	ISI AUG OWN PRE	- - - -	- - - -	- - - -	- - - -	- - - -	- - - -
C-F-1 C5.11 2	V2 21204-006-73 D 21204-006-73 D 1204		ISI-21204-006 12" FLANGE TO PIPE	ISI AUG OWN PRE	- - - -	- - - -	- - - -	- - - -	- - - -	- - - -
C-F-1 C5.11 2	V2 21204-006-74 21204-006-74 1204		ISI-21204-006 12" PIPE TO ELBOW	ISI AUG OWN PRE	- - - -	- - - -	- - - -	- - - -	- - - -	- - - -
C-F-1 C5.11 2	V2 21204-006-75 21204-006-75 1204		ISI-21204-006 12" ELBOW TO PIPE	ISI AUG OWN PRE	- - - -	- - - -	- - - -	- - - -	- - - -	- - - -
C-F-1 C5.11 2	V2 21204-006-76 21204-006-76 1204		ISI-21204-006 12" PIPE TO ELBOW	ISI AUG OWN PRE	- - - -	- - - -	- - - -	- - - -	- - - -	- - - -
C-F-1 C5.11 2	V2 21204-006-77 21204-006-77 1204		ISI-21204-006 12" ELBOW TO PIPE	ISI AUG OWN PRE	- - - -	- - - -	- - - -	- - - -	- - - -	- - - -
C-F-1 C5.11 2	V2 21204-006-79 21204-006-79 1204		ISI-21204-006 12" PIPE TO ELBOW	ISI AUG OWN PRE	- - - -	- - - -	- - - -	- - - -	- - - -	- - - -
C-F-1 C5.11 2	V2 21204-006-8 21204-006-8 1204		ISI-21204-006 24" PIPE TO PIPE	ISI AUG OWN PRE	- - - -	- - - -	- - - -	- - - -	- - - -	- - - -

Southern Nuclear Operating Company
3rd Interval
VOGTLE-2 ISI PLAN, VERSION 3.0

Category, Item No., Class	Summary No./CompID/System	Scope / Method / Procedure	Dwg/ISO No. Comp. Desc. Code Case		Period 1		Period 2		Period 3	
					2VR13	2VR14	2VR14A	2VR15	2VR16	2VR17
C-F-1	V2 21204-006-80		ISI-21204-006	ISI	-	-	-	-	-	-
C5.11	21204-006-80		12" ELBOW TO PIPE (AI 87-0131)	AUG	-	-	-	-	-	-
2	1204			OWN	-	-	-	-	-	-
				PRE	-	-	-	-	-	-
C-F-1	V2 21204-006-81		ISI-21204-006	ISI	-	-	-	-	-	-
C5.11	21204-006-81		12" PIPE TO VALVE	AUG	-	-	-	-	-	-
2	1204			OWN	-	-	-	-	-	-
				PRE	-	-	-	-	-	-
C-F-1	V2 21204-007-1		ISI-21204-007	ISI	-	-	-	-	-	-
C5.11	21204-007-1		10" ECC. REDUCER TO PIPE	AUG	-	-	-	-	-	-
2	1204			OWN	-	-	-	-	-	-
				PRE	-	-	-	-	-	-
C-F-1	V2 21204-007-10		ISI-21204-007	ISI	-	-	-	-	-	-
C5.11	21204-007-10		10" ELBOW TO PIPE	AUG	-	-	-	-	-	-
2	1204			OWN	-	-	-	-	-	-
				PRE	-	-	-	-	-	-
C-F-1	V2 21204-007-11		ISI-21204-007	ISI	-	-	-	-	-	-
C5.11	21204-007-11		10" PIPE TO ELBOW	AUG	-	-	-	-	-	-
2	1204			OWN	-	-	-	-	-	-
				PRE	-	-	-	-	-	-
C-F-1	V2 21204-007-12		ISI-21204-007	ISI	-	-	-	-	-	-
C5.11	21204-007-12		10" ELBOW TO PIPE	AUG	-	-	-	-	-	-
2	1204			OWN	-	-	-	-	-	-
				PRE	-	-	-	-	-	-
C-F-1	V2 21204-007-15		ISI-21204-007	ISI	-	-	-	-	-	-
C5.11	21204-007-15		10" PIPE TO ELBOW	AUG	-	-	-	-	-	-
2	1204			OWN	-	-	-	-	-	-
				PRE	-	-	-	-	-	-
C-F-1	V2 21204-007-16		ISI-21204-007	ISI	-	-	-	-	-	-
C5.11	21204-007-16		10" ELBOW TO PIPE	AUG	-	-	-	-	-	-
2	1204			OWN	-	-	-	-	-	-
				PRE	-	-	-	-	-	-
C-F-1	V2 21204-007-17		ISI-21204-007	ISI	-	-	-	-	-	-
C5.11	21204-007-17		10" PIPE TO VALVE	AUG	-	-	-	-	-	-
2	1204			OWN	-	-	-	-	-	-
				PRE	-	-	-	-	-	-
C-F-1	V2 21204-007-2		ISI-21204-007	ISI	-	-	-	-	-	-
C5.11	21204-007-2		10" PIPE TO PIPE	AUG	-	-	-	-	-	-
2	1204			OWN	-	-	-	-	-	-
				PRE	-	-	-	-	-	-

Southern Nuclear Operating Company
3rd Interval
VOGTLE-2 ISI PLAN, VERSION 3.0

Category, Item No., Class	Summary No./CompID/System	Scope / Method / Procedure	Dwg/ISO No. Comp. Desc. Code Case		Period 1		Period 2			Period 3	
					2VR13	2VR14	2VR14A	2VR15	2VR16	2VR17	2VR18
C-F-1	V2 21204-007-3		ISI-21204-007	ISI	-	-	-	-	-	-	-
C5.11	21204-007-3		10" PIPE TO PIPE	AUG	-	-	-	-	-	-	-
2	1204			OWN	-	-	-	-	-	-	-
				PRE	-	-	-	-	-	-	-
C-F-1	V2 21204-007-4		ISI-21204-007	ISI	-	-	-	-	-	-	-
C5.11	21204-007-4		10" PIPE TO PIPE	AUG	-	-	-	-	-	-	-
2	1204			OWN	-	-	-	-	-	-	-
				PRE	-	-	-	-	-	-	-
C-F-1	V2 21204-007-6		ISI-21204-007	ISI	-	-	-	-	-	-	-
C5.11	21204-007-6		10" PIPE TO ELBOW	AUG	-	-	-	-	-	-	-
2	1204			OWN	-	-	-	-	-	-	-
				PRE	-	-	-	-	-	-	-
C-F-1	V2 21204-007-7		ISI-21204-007	ISI	-	-	-	-	-	-	-
C5.11	21204-007-7		10" ELBOW TO PIPE	AUG	-	-	-	-	-	-	-
2	1204			OWN	-	-	-	-	-	-	-
				PRE	-	-	-	-	-	-	-
C-F-1	V2 21204-007-9		ISI-21204-007	ISI	-	-	-	-	-	-	-
C5.11	21204-007-9		10" PIPE TO ELBOW	AUG	-	-	-	-	-	-	-
2	1204			OWN	-	-	-	-	-	-	-
				PRE	-	-	-	-	-	-	-
C-F-1	V2 21204-008-1	ISI/UT/	ISI-21204-008	ISI	-	-	-	-	-	s	-
C5.11	21204-008-1		8" BRANCH CONNECTION TO PIPE	AUG	-	-	-	-	-	-	-
2	1204			OWN	-	-	-	-	-	-	-
				PRE	-	-	-	-	-	-	-
C-F-1	V2 21204-008-10	ISI/UT/	ISI-21204-008	ISI	-	-	-	s	-	-	-
C5.11	21204-008-10		8" PIPE TO VALVE (AI 87-0131)	AUG	-	-	-	-	-	-	-
2	1204			OWN	-	-	-	-	-	-	-
				PRE	-	-	-	-	-	-	-
C-F-1	V2 21204-008-11		ISI-21204-008	ISI	-	-	-	-	-	-	-
C5.11	21204-008-11		8" VALVE TO PIPE	AUG	-	-	-	-	-	-	-
2	1204			OWN	-	-	-	-	-	-	-
				PRE	-	-	-	-	-	-	-
C-F-1	V2 21204-008-12		ISI-21204-008	ISI	-	-	-	-	-	-	-
C5.11	21204-008-12		8" PIPE TO VALVE	AUG	-	-	-	-	-	-	-
2	1204			OWN	-	-	-	-	-	-	-
				PRE	-	-	-	-	-	-	-
C-F-1	V2 21204-008-13	ISI/UT/	ISI-21204-008	ISI	-	-	-	-	-	s	-
C5.11	21204-008-13		8" VALVE TO PIPE (AI 87-0131)	AUG	-	-	-	-	-	-	-
2	1204			OWN	-	-	-	-	-	-	-
				PRE	-	-	-	-	-	-	-

Southern Nuclear Operating Company
3rd Interval
VOGTLE-2 ISI PLAN, VERSION 3.0

Category, Item No., Class	Summary No./ComplD/System	Scope / Method / Procedure	Dwg/ISO No. Comp. Desc. Code Case		Period 1		Period 2			Period 3	
					2VR13	2VR14	2VR14A	2VR15	2VR16	2VR17	2VR18
C-F-1	V2 21204-008-14		ISI-21204-008	ISI	-	-	-	-	-	-	-
C5.11	21204-008-14		8" PIPE TO ELBOW	AUG	-	-	-	-	-	-	-
2	1204			OWN	-	-	-	-	-	-	-
				PRE	-	-	-	-	-	-	-
C-F-1	V2 21204-008-15		ISI-21204-008	ISI	-	-	-	-	-	-	-
C5.11	21204-008-15		8" ELBOW TO PIPE	AUG	-	-	-	-	-	-	-
2	1204			OWN	-	-	-	-	-	-	-
				PRE	-	-	-	-	-	-	-
C-F-1	V2 21204-008-16		ISI-21204-008	ISI	-	-	-	-	-	-	-
C5.11	21204-008-16		8" PIPE TO ELBOW	AUG	-	-	-	-	-	-	-
2	1204			OWN	-	-	-	-	-	-	-
				PRE	-	-	-	-	-	-	-
C-F-1	V2 21204-008-17		ISI-21204-008	ISI	-	-	-	-	-	-	-
C5.11	21204-008-17		8" ELBOW TO PIPE	AUG	-	-	-	-	-	-	-
2	1204			OWN	-	-	-	-	-	-	-
				PRE	-	-	-	-	-	-	-
C-F-1	V2 21204-008-18		ISI-21204-008	ISI	-	-	-	-	-	-	-
C5.11	21204-008-18		8" PIPE TO PIPE	AUG	-	-	-	-	-	-	-
2	1204			OWN	-	-	-	-	-	-	-
				PRE	-	-	-	-	-	-	-
C-F-1	V2 21204-008-19		ISI-21204-008	ISI	-	-	-	-	-	-	-
C5.11	21204-008-19		8" PIPE TO TEE	AUG	-	-	-	-	-	-	-
2	1204			OWN	-	-	-	-	-	-	-
				PRE	-	-	-	-	-	-	-
C-F-1	V2 21204-008-2		ISI-21204-008	ISI	-	-	-	-	-	-	-
C5.11	21204-008-2		8" PIPE TO PIPE	AUG	-	-	-	-	-	-	-
2	1204			OWN	-	-	-	-	-	-	-
				PRE	-	-	-	-	-	-	-
C-F-1	V2 21204-008-20		ISI-21204-008	ISI	-	-	-	-	-	-	-
C5.11	21204-008-20		8" TEE TO PIPE	AUG	-	-	-	-	-	-	-
2	1204			OWN	-	-	-	-	-	-	-
				PRE	-	-	-	-	-	-	-
C-F-1	V2 21204-008-21		ISI-21204-008	ISI	-	-	-	-	-	-	-
C5.11	21204-008-21		8" PIPE TO REDUCER	AUG	-	-	-	-	-	-	-
2	1204			OWN	-	-	-	-	-	-	-
				PRE	-	-	-	-	-	-	-
C-F-1	V2 21204-008-22		ISI-21204-008	ISI	-	-	-	-	-	-	-
C5.11	21204-008-22		6" REDUCER TO PIPE	AUG	-	-	-	-	-	-	-
2	1204			OWN	-	-	-	-	-	-	-
				PRE	-	-	-	-	-	-	-

Southern Nuclear Operating Company
3rd Interval
VOGTLE-2 ISI PLAN, VERSION 3.0

Category, Item No., Class	Summary No./ComplID/System	Scope / Method / Procedure	Dwg/ISO No. Comp. Desc. Code Case		Period 1		Period 2		Period 3	
					2VR13	2VR14	2VR14A	2VR15	2VR16	2VR17
C-F-1	V2 21204-008-23		ISI-21204-008	ISI	-	-	-	-	-	-
C5.11	21204-008-23		6" PIPE TO ELBOW	AUG	-	-	-	-	-	-
2	1204			OWN	-	-	-	-	-	-
				PRE	-	-	-	-	-	-
C-F-1	V2 21204-008-24		ISI-21204-008	ISI	-	-	-	-	-	-
C5.11	21204-008-24		6" ELBOW TO PIPE	AUG	-	-	-	-	-	-
2	1204			OWN	-	-	-	-	-	-
				PRE	-	-	-	-	-	-
C-F-1	V2 21204-008-25		ISI-21204-008	ISI	-	-	-	-	-	-
C5.11	21204-008-25		6" PIPE TO ELBOW	AUG	-	-	-	-	-	-
2	1204			OWN	-	-	-	-	-	-
				PRE	-	-	-	-	-	-
C-F-1	V2 21204-008-26		ISI-21204-008	ISI	-	-	-	-	-	-
C5.11	21204-008-26		6" ELBOW TO PIPE	AUG	-	-	-	-	-	-
2	1204			OWN	-	-	-	-	-	-
				PRE	-	-	-	-	-	-
C-F-1	V2 21204-008-27		ISI-21204-008	ISI	-	-	-	-	-	-
C5.11	21204-008-27		6" PIPE TO ELBOW	AUG	-	-	-	-	-	-
2	1204			OWN	-	-	-	-	-	-
				PRE	-	-	-	-	-	-
C-F-1	V2 21204-008-28		ISI-21204-008	ISI	-	-	-	-	-	-
C5.11	21204-008-28		6" ELBOW TO PIPE	AUG	-	-	-	-	-	-
2	1204			OWN	-	-	-	-	-	-
				PRE	-	-	-	-	-	-
C-F-1	V2 21204-008-29		ISI-21204-008	ISI	-	-	-	-	-	-
C5.11	21204-008-29		6" PIPE TO VALVE	AUG	-	-	-	-	-	-
2	1204			OWN	-	-	-	-	-	-
				PRE	-	-	-	-	-	-
C-F-1	V2 21204-008-3	ISI/UT/	ISI-21204-008	ISI	-	-	s	-	-	-
C5.11	21204-008-3		8" PIPE TO ELBOW (AI 87-0131)	AUG	-	-	-	-	-	-
2	1204			OWN	-	-	-	-	-	-
				PRE	-	-	-	-	-	-
C-F-1	V2 21204-008-30		ISI-21204-008	ISI	-	-	-	-	-	-
C5.11	21204-008-30		6" VALVE TO PIPE	AUG	-	-	-	-	-	-
2	1204			OWN	-	-	-	-	-	-
				PRE	-	-	-	-	-	-
C-F-1	V2 21204-008-31		ISI-21204-008	ISI	-	-	-	-	-	-
C5.11	21204-008-31		6" PIPE TO VALVE	AUG	-	-	-	-	-	-
2	1204			OWN	-	-	-	-	-	-
				PRE	-	-	-	-	-	-

**Southern Nuclear Operating Company
3rd Interval
VOGTLE-2 ISI PLAN, VERSION 3.0**

Category, Item No., Class	Summary No./CompID/System	Scope / Method / Procedure	Dwg/ISO No. Comp. Desc. Code Case		Period 1		Period 2		Period 3		
					2VR13	2VR14	2VR14A	2VR15	2VR16	2VR17	2VR18
C-F-1 C5.11 2	V2 21204-008-32 21204-008-32 1204		ISI-21204-008 6" VALVE TO PIPE	ISI AUG OWN PRE	- - - -	- - - -	- - - -	- - - -	- - - -	- - - -	
C-F-1 C5.11 2	V2 21204-008-33 21204-008-33 1204		ISI-21204-008 6" PIPE TO TEE	ISI AUG OWN PRE	- - - -	- - - -	- - - -	- - - -	- - - -	- - - -	
C-F-1 C5.11 2	V2 21204-008-34 21204-008-34 1204		ISI-21204-008 6" TEE TO PIPE	ISI AUG OWN PRE	- - - -	- - - -	- - - -	- - - -	- - - -	- - - -	
C-F-1 C5.11 2	V2 21204-008-34 A 21204-008-34 A 1204		ISI-21204-008 6" PIPE TO PIPE	ISI AUG OWN PRE	- - - -	- - - -	- - - -	- - - -	- - - -	- - - -	
C-F-1 C5.11 2	V2 21204-008-35 21204-008-35 1204	ISI/UT/	ISI-21204-008 6" PIPE TO ELBOW (AI 87-0131)	ISI AUG OWN PRE	- - - -	- - - -	- s - -	- - - -	- - - -	- - - -	
C-F-1 C5.11 2	V2 21204-008-36 21204-008-36 1204	ISI/UT/	ISI-21204-008 6" ELBOW TO PIPE (AI 87-0131)	ISI AUG OWN PRE	- - - -	- - - -	- - s -	- - - -	- - - -	- - - -	
C-F-1 C5.11 2	V2 21204-008-37 21204-008-37 1204	ISI/UT/	ISI-21204-008 6" PIPE TO ELBOW (AI 87-0131)	ISI AUG OWN PRE	- - - -	- - - -	- s - -	- - - -	- - - -	- - - -	
C-F-1 C5.11 2	V2 21204-008-38 21204-008-38 1204	ISI/UT/	ISI-21204-008 6" ELBOW TO PIPE (AI 87-0131)	ISI AUG OWN PRE	- - - -	- - - -	- - s -	- - - -	- - - -	- - - -	
C-F-1 C5.11 2	V2 21204-008-39 21204-008-39 1204		ISI-21204-008 6" PIPE TO FLANGE	ISI AUG OWN PRE	- - - -	- - - -	- - - -	- - - -	- - - -	- - - -	
C-F-1 C5.11 2	V2 21204-008-4 21204-008-4 1204	ISI/UT/	ISI-21204-008 8" ELBOW TO PIPE (AI 87-0131)	ISI AUG OWN PRE	- - - -	- - - -	- s - -	- - - -	- - - -	- - - -	

Southern Nuclear Operating Company
3rd Interval
VOGTLE-2 ISI PLAN, VERSION 3.0

Category, Item No., Class	Summary No./ComplD/System	Scope / Method / Procedure	Dwg/ISO No. Comp. Desc. Code Case		Period 1		Period 2			Period 3	
					2VR13	2VR14	2VR14A	2VR15	2VR16	2VR17	2VR18
C-F-1	V2 21204-008-40		ISI-21204-008	ISI	-	-	-	-	-	-	-
C5.11	21204-008-40		6" FLANGE TO PIPE	AUG	-	-	-	-	-	-	-
2	1204			OWN	-	-	-	-	-	-	-
				PRE	-	-	-	-	-	-	-
C-F-1	V2 21204-008-41		ISI-21204-008	ISI	-	-	-	-	-	-	-
C5.11	21204-008-41		6" PIPE TO FLANGE	AUG	-	-	-	-	-	-	-
2	1204			OWN	-	-	-	-	-	-	-
				PRE	-	-	-	-	-	-	-
C-F-1	V2 21204-008-6		ISI-21204-008	ISI	-	-	-	-	-	-	-
C5.11	21204-008-6		8" PIPE TO ELBOW	AUG	-	-	-	-	-	-	-
2	1204			OWN	-	-	-	-	-	-	-
				PRE	-	-	-	-	-	-	-
C-F-1	V2 21204-008-7		ISI-21204-008	ISI	-	-	-	-	-	-	-
C5.11	21204-008-7		8" ELBOW TO PIPE	AUG	-	-	-	-	-	-	-
2	1204			OWN	-	-	-	-	-	-	-
				PRE	-	-	-	-	-	-	-
C-F-1	V2 21204-008-8		ISI-21204-008	ISI	-	-	-	-	-	-	-
C5.11	21204-008-8		8" PIPE TO ELBOW	AUG	-	-	-	-	-	-	-
2	1204			OWN	-	-	-	-	-	-	-
				PRE	-	-	-	-	-	-	-
C-F-1	V2 21204-008-9		ISI-21204-008	ISI	-	-	-	-	-	-	-
C5.11	21204-008-9		8" ELBOW TO PIPE	AUG	-	-	-	-	-	-	-
2	1204			OWN	-	-	-	-	-	-	-
				PRE	-	-	-	-	-	-	-
C-F-1	V2 21204-010-1	ISI/UT/	ISI-21204-010	ISI	-	-	-	s	-	-	-
C5.11	21204-010-1		6" TEE TO PIPE (AI 87-0131)	AUG	-	-	-	-	-	-	-
2	1204			OWN	-	-	-	-	-	-	-
				PRE	-	-	-	-	-	-	-
C-F-1	V2 21204-010-10		ISI-21204-010	ISI	-	-	-	-	-	-	-
C5.11	21204-010-10		6" PIPE TO VALVE	AUG	-	-	-	-	-	-	-
2	1204			OWN	-	-	-	-	-	-	-
				PRE	-	-	-	-	-	-	-
C-F-1	V2 21204-010-11		ISI-21204-010	ISI	-	-	-	-	-	-	-
C5.11	21204-010-11		6" VALVE TO PIPE	AUG	-	-	-	-	-	-	-
2	1204			OWN	-	-	-	-	-	-	-
				PRE	-	-	-	-	-	-	-
C-F-1	V2 21204-010-12		ISI-21204-010	ISI	-	-	-	-	-	-	-
C5.11	21204-010-12		6" PIPE TO VALVE	AUG	-	-	-	-	-	-	-
2	1204			OWN	-	-	-	-	-	-	-
				PRE	-	-	-	-	-	-	-

Southern Nuclear Operating Company
3rd Interval
VOGTLE-2 ISI PLAN, VERSION 3.0

Category, Item No., Class.	Summary No./ComplD/System	Scope / Method / Procedure	Dwg/ISO No. Comp. Desc. Code Case		Period 1		Period 2			Period 3	
					2VR13	2VR14	2VR14A	2VR15	2VR16	2VR17	2VR18
C-F-1 C5.11 2	V2 21204-010-13 21204-010-13 1204		ISI-21204-010 6" VALVE TO PIPE	ISI AUG OWN PRE	-	-	-	-	-	-	-
C-F-1 C5.11 2	V2 21204-010-14 21204-010-14 1204		ISI-21204-010 6" PIPE TO REDUCER	ISI AUG OWN PRE	-	-	-	-	-	-	-
C-F-1 C5.11 2	V2 21204-010-15 21204-010-15 1204	ISI/UT/	ISI-21204-010 8" REDUCER TO PIPE	ISI AUG OWN PRE	-	-	-	-	-	s	-
C-F-1 C5.11 2	V2 21204-010-16 21204-010-16 1204		ISI-21204-010 8" PIPE TO TEE	ISI AUG OWN PRE	-	-	-	-	-	-	-
C-F-1 C5.11 2	V2 21204-010-17 21204-010-17 1204		ISI-21204-010 6" TEE TO PIPE	ISI AUG OWN PRE	-	-	-	-	-	-	-
C-F-1 C5.11 2	V2 21204-010-18 21204-010-18 1204		ISI-21204-010 6" PIPE TO ELBOW	ISI AUG OWN PRE	-	-	-	-	-	-	-
C-F-1 C5.11 2	V2 21204-010-19 21204-010-19 1204		ISI-21204-010 6" ELBOW TO PIPE	ISI AUG OWN PRE	-	-	-	-	-	-	-
C-F-1 C5.11 2	V2 21204-010-2 21204-010-2 1204	ISI/UT/	ISI-21204-010 6" PIPE TO ELBOW (AI 87-0131)	ISI AUG OWN PRE	-	-	-	s	-	-	-
C-F-1 C5.11 2	V2 21204-010-20 21204-010-20 1204		ISI-21204-010 6" PIPE TO FLANGE	ISI AUG OWN PRE	-	-	-	-	-	-	-
C-F-1 C5.11 2	V2 21204-010-21 21204-010-21 1204		ISI-21204-010 6" FLANGE TO PIPE	ISI AUG OWN PRE	-	-	-	-	-	-	-

Southern Nuclear Operating Company
3rd Interval
VOGTLE-2 ISI PLAN, VERSION 3.0

Category, Item No., Class	Summary No./ComplID/System	Scope / Method / Procedure	Dwg/ISO No. Comp. Desc. Code Case		Period 1		Period 2			Period 3	
					2VR13	2VR14	2VR14A	2VR15	2VR16	2VR17	2VR18
C-F-1 C5.11 2	V2 21204-010-22 21204-010-22 1204		ISI-21204-010 6" PIPE TO FLANGE	ISI AUG OWN PRE	-	-	-	-	-	-	-
C-F-1 C5.11 2	V2 21204-010-3 21204-010-3 1204		ISI-21204-010 6" ELBOW TO PIPE	ISI AUG OWN PRE	-	-	-	-	-	-	-
C-F-1 C5.11 2	V2 21204-010-4 21204-010-4 1204		ISI-21204-010 6" PIPE TO ELBOW	ISI AUG OWN PRE	-	-	-	-	-	-	-
C-F-1 C5.11 2	V2 21204-010-5 21204-010-5 1204		ISI-21204-010 6" ELBOW TO PIPE	ISI AUG OWN PRE	-	-	-	-	-	-	-
C-F-1 C5.11 2	V2 21204-010-6 21204-010-6 1204		ISI-21204-010 6" PIPE TO ELBOW	ISI AUG OWN PRE	-	-	-	-	-	-	-
C-F-1 C5.11 2	V2 21204-010-7 21204-010-7 1204		ISI-21204-010 6" ELBOW TO PIPE	ISI AUG OWN PRE	-	-	-	-	-	-	-
C-F-1 C5.11 2	V2 21204-010-8 21204-010-8 1204		ISI-21204-010 6" PIPE TO ELBOW	ISI AUG OWN PRE	-	-	-	-	-	-	-
C-F-1 C5.11 2	V2 21204-010-9 21204-010-9 1204		ISI-21204-010 6" ELBOW TO PIPE	ISI AUG OWN PRE	-	-	-	-	-	-	-
C-F-1 C5.11 2	V2 21204-011-1 21204-011-1 1204		ISI-21204-011 6" TEE TO PIPE	ISI AUG OWN PRE	-	-	-	-	-	-	-
C-F-1 C5.11 2	V2 21204-011-10 21204-011-10 1204		ISI-21204-011 6" PIPE TO TEE	ISI AUG OWN PRE	-	-	-	-	-	-	-

Southern Nuclear Operating Company
3rd Interval
VOGTLE-2 ISI PLAN, VERSION 3.0

Category, Item No., Class	Summary No./ComplD/System	Scope / Method / Procedure	Dwg/ISO No. Comp. Desc. Code Case		Period 1		Period 2		Period 3	
					2VR13	2VR14	2VR14A	2VR15	2VR16	2VR17
C-F-1 C5.11 2	V2 21204-011-11 21204-011-11 1204		ISI-21204-011 6" TEE TO PIPE	ISI AUG OWN PRE	-	-	-	-	-	-
C-F-1 C5.11 2	V2 21204-011-12 21204-011-12 1204		ISI-21204-011 6" PIPE TO VALVE	ISI AUG OWN PRE	-	-	-	-	-	-
C-F-1 C5.11 2	V2 21204-011-13 21204-011-13 1204	ISI/UT/	ISI-21204-011 6" TEE TO PIPE (AI 87-0131)	ISI AUG OWN PRE	-	-	-	-	s	-
C-F-1 C5.11 2	V2 21204-011-14 21204-011-14 1204		ISI-21204-011 6" PIPE TO ELBOW	ISI AUG OWN PRE	-	-	-	-	-	-
C-F-1 C5.11 2	V2 21204-011-15 21204-011-15 1204		ISI-21204-011 6" ELBOW TO PIPE	ISI AUG OWN PRE	-	-	-	-	-	-
C-F-1 C5.11 2	V2 21204-011-16 21204-011-16 1204		ISI-21204-011 6" PIPE TO VALVE	ISI AUG OWN PRE	-	-	-	-	-	-
C-F-1 C5.11 2	V2 21204-011-17 21204-011-17 1204		ISI-21204-011 6" VALVE TO PIPE	ISI AUG OWN PRE	-	-	-	-	-	-
C-F-1 C5.11 2	V2 21204-011-19 21204-011-19 1204		ISI-21204-011 6" PIPE TO ELBOW	ISI AUG OWN PRE	-	-	-	-	-	-
C-F-1 C5.11 2	V2 21204-011-2 21204-011-2 1204		ISI-21204-011 6" PIPE TO ELBOW	ISI AUG OWN PRE	-	-	-	-	-	-
C-F-1 C5.11 2	V2 21204-011-20 21204-011-20 1204		ISI-21204-011 6" ELBOW TO PIPE	ISI AUG OWN PRE	-	-	-	-	-	-

Southern Nuclear Operating Company
3rd Interval
VOGTLE-2 ISI PLAN, VERSION 3.0

Category, Item No., Class	Summary No./ComplID/System	Scope / Method / Procedure	Dwg/ISO No. Comp. Desc. Code Case		Period 1		Period 2		Period 3	
					2VR13	2VR14	2VR14A	2VR15	2VR16	2VR17
C-F-1 C5.11 2	V2 21204-011-21 21204-011-21 1204		ISI-21204-011 6" PIPE TO TEE	ISI AUG OWN PRE	-	-	-	-	-	-
C-F-1 C5.11 2	V2 21204-011-3 21204-011-3 1204		ISI-21204-011 6" ELBOW TO PIPE	ISI AUG OWN PRE	-	-	-	-	-	-
C-F-1 C5.11 2	V2 21204-011-4 21204-011-4 1204	ISI/UT/NMP-ES-024-501	ISI-21204-011 6" PIPE TO ELBOW	ISI AUG OWN PRE	-	s	-	-	-	-
C-F-1 C5.11 2	V2 21204-011-5 21204-011-5 1204		ISI-21204-011 6" ELBOW TO PIPE	ISI AUG OWN PRE	-	-	-	-	-	-
C-F-1 C5.11 2	V2 21204-011-6 21204-011-6 1204		ISI-21204-011 6" PIPE TO TEE (AI 87-0131)	ISI AUG OWN PRE	-	-	-	-	-	-
C-F-1 C5.11 2	V2 21204-011-7 21204-011-7 1204		ISI-21204-011 6" TEE TO PIPE	ISI AUG OWN PRE	-	-	-	-	-	-
C-F-1 C5.11 2	V2 21204-011-8 21204-011-8 1204		ISI-21204-011 6" PIPE TO VALVE	ISI AUG OWN PRE	-	-	-	-	-	-
C-F-1 C5.11 2	V2 21204-011-9 21204-011-9 1204		ISI-21204-011 6" VALVE TO PIPE	ISI AUG OWN PRE	-	-	-	-	-	-
C-F-1 C5.11 2	V2 21204-012-1 21204-012-1 1204	ISI/UT/	ISI-21204-012 8" VALVE TO PIPE (AI 87-0131)	ISI AUG OWN PRE	-	-	s	-	-	-
C-F-1 C5.11 2	V2 21204-012-10 21204-012-10 1204	ISI/UT/	ISI-21204-012 8" ELBOW TO PIPE (AI 87-0131)	ISI AUG OWN PRE	-	-	s	-	-	-

Southern Nuclear Operating Company
3rd Interval
VOGTLE-2 ISI PLAN, VERSION 3.0

Category, Item No., Class	Summary No./CompID/System	Scope / Method / Procedure	Dwg/ISO No. Comp. Desc. Code Case		Period 1		Period 2		Period 3	
					2VR13	2VR14	2VR14A	2VR15	2VR16	2VR17
C-F-1	V2 21204-012-11		ISI-21204-012	ISI	-	-	-	-	-	-
C5.11	21204-012-11		8" PIPE TO ELBOW	AUG	-	-	-	-	-	-
2	1204			OWN	-	-	-	-	-	-
				PRE	-	-	-	-	-	-
C-F-1	V2 21204-012-12		ISI-21204-012	ISI	-	-	-	-	-	-
C5.11	21204-012-12		8" ELBOW TO PIPE	AUG	-	-	-	-	-	-
2	1204			OWN	-	-	-	-	-	-
				PRE	-	-	-	-	-	-
C-F-1	V2 21204-012-13		ISI-21204-012	ISI	-	-	-	-	-	-
C5.11	21204-012-13		8" PIPE TO ELBOW	AUG	-	-	-	-	-	-
2	1204			OWN	-	-	-	-	-	-
				PRE	-	-	-	-	-	-
C-F-1	V2 21204-012-14		ISI-21204-012	ISI	-	-	-	-	-	-
C5.11	21204-012-14		8" ELBOW TO PIPE	AUG	-	-	-	-	-	-
2	1204			OWN	-	-	-	-	-	-
				PRE	-	-	-	-	-	-
C-F-1	V2 21204-012-15		ISI-21204-012	ISI	-	-	-	-	-	-
C5.11	21204-012-15		8" PIPE TO ELBOW	AUG	-	-	-	-	-	-
2	1204			OWN	-	-	-	-	-	-
				PRE	-	-	-	-	-	-
C-F-1	V2 21204-012-16		ISI-21204-012	ISI	-	-	-	-	-	-
C5.11	21204-012-16		8" ELBOW TO PIPE	AUG	-	-	-	-	-	-
2	1204			OWN	-	-	-	-	-	-
				PRE	-	-	-	-	-	-
C-F-1	V2 21204-012-18		ISI-21204-012	ISI	-	-	-	-	-	-
C5.11	21204-012-18		8" PIPE TO PIPE	AUG	-	-	-	-	-	-
2	1204			OWN	-	-	-	-	-	-
				PRE	-	-	-	-	-	-
C-F-1	V2 21204-012-19		ISI-21204-012	ISI	-	-	-	-	-	-
C5.11	21204-012-19		8" PIPE TO ELBOW	AUG	-	-	-	-	-	-
2	1204			OWN	-	-	-	-	-	-
				PRE	-	-	-	-	-	-
C-F-1	V2 21204-012-2		ISI-21204-012	ISI	-	-	-	-	-	-
C5.11	21204-012-2		8" PIPE TO VALVE (AI 87-0131)	AUG	-	-	-	-	-	-
2	1204			OWN	-	-	-	-	-	-
				PRE	-	-	-	-	-	-
C-F-1	V2 21204-012-20		ISI-21204-012	ISI	-	-	-	-	-	-
C5.11	21204-012-20		8" ELBOW TO PIPE	AUG	-	-	-	-	-	-
2	1204			OWN	-	-	-	-	-	-
				PRE	-	-	-	-	-	-

Southern Nuclear Operating Company
3rd Interval
VOGTLE-2 ISI PLAN, VERSION 3.0

Category, Item No., Class	Summary No./ComplD/System	Scope / Method / Procedure	Dwg/ISO No. Comp. Desc. Code Case		Period 1		Period 2			Period 3	
					2VR13	2VR14	2VR14A	2VR15	2VR16	2VR17	2VR18
C-F-1	V2 21204-012-21		ISI-21204-012	ISI	-	-	-	-	-	-	-
C5.11	21204-012-21		8" PIPE TO PIPE	AUG	-	-	-	-	-	-	-
2	1204			OWN	-	-	-	-	-	-	-
				PRE	-	-	-	-	-	-	-
C-F-1	V2 21204-012-22		ISI-21204-012	ISI	-	-	-	-	-	-	-
C5.11	21204-012-22		8" PIPE TO ELBOW	AUG	-	-	-	-	-	-	-
2	1204			OWN	-	-	-	-	-	-	-
				PRE	-	-	-	-	-	-	-
C-F-1	V2 21204-012-23		ISI-21204-012	ISI	-	-	-	-	-	-	-
C5.11	21204-012-23		8" ELBOW TO PIPE	AUG	-	-	-	-	-	-	-
2	1204			OWN	-	-	-	-	-	-	-
				PRE	-	-	-	-	-	-	-
C-F-1	V2 21204-012-24		ISI-21204-012	ISI	-	-	-	-	-	-	-
C5.11	21204-012-24		8" PIPE TO ELBOW	AUG	-	-	-	-	-	-	-
2	1204			OWN	-	-	-	-	-	-	-
				PRE	-	-	-	-	-	-	-
C-F-1	V2 21204-012-25		ISI-21204-012	ISI	-	-	-	-	-	-	-
C5.11	21204-012-25		8" ELBOW TO PIPE	AUG	-	-	-	-	-	-	-
2	1204			OWN	-	-	-	-	-	-	-
				PRE	-	-	-	-	-	-	-
C-F-1	V2 21204-012-27		ISI-21204-012	ISI	-	-	-	-	-	-	-
C5.11	21204-012-27		8" PIPE TO ELBOW	AUG	-	-	-	-	-	-	-
2	1204			OWN	-	-	-	-	-	-	-
				PRE	-	-	-	-	-	-	-
C-F-1	V2 21204-012-28		ISI-21204-012	ISI	-	-	-	-	-	-	-
C5.11	21204-012-28		8" ELBOW TO PIPE	AUG	-	-	-	-	-	-	-
2	1204			OWN	-	-	-	-	-	-	-
				PRE	-	-	-	-	-	-	-
C-F-1	V2 21204-012-29		ISI-21204-012	ISI	-	-	-	-	-	-	-
C5.11	21204-012-29		8" PIPE TO PIPE	AUG	-	-	-	-	-	-	-
2	1204			OWN	-	-	-	-	-	-	-
				PRE	-	-	-	-	-	-	-
C-F-1	V2 21204-012-3		ISI-21204-012	ISI	-	-	-	-	-	-	-
C5.11	21204-012-3		8" VALVE TO PIPE	AUG	-	-	-	-	-	-	-
2	1204			OWN	-	-	-	-	-	-	-
				PRE	-	-	-	-	-	-	-
C-F-1	V2 21204-012-31		ISI-21204-012	ISI	-	-	-	-	-	-	-
C5.11	21204-012-31		8" PIPE TO ELBOW	AUG	-	-	-	-	-	-	-
2	1204			OWN	-	-	-	-	-	-	-
				PRE	-	-	-	-	-	-	-

Southern Nuclear Operating Company
3rd Interval
VOGTLE-2 ISI PLAN, VERSION 3.0

Category, Item No., Class	Summary No./Compld/System	Scope / Method / Procedure	Dwg/ISO No. Comp. Desc. Code Case		Period 1		Period 2			Period 3	
					2VR13	2VR14	2VR14A	2VR15	2VR16	2VR17	2VR18
C-F-1	V2 21204-012-32		ISI-21204-012	ISI	-	-	-	-	-	-	-
C5.11	21204-012-32		8" ELBOW TO PIPE	AUG	-	-	-	-	-	-	-
2	1204			OWN	-	-	-	-	-	-	-
				PRE	-	-	-	-	-	-	-
C-F-1	V2 21204-012-33		ISI-21204-012	ISI	-	-	-	-	-	-	-
C5.11	21204-012-33		8" PIPE TO TEE	AUG	-	-	-	-	-	-	-
2	1204			OWN	-	-	-	-	-	-	-
				PRE	-	-	-	-	-	-	-
C-F-1	V2 21204-012-4		ISI-21204-012	ISI	-	-	-	-	-	-	-
C5.11	21204-012-4		8" PIPE TO ELBOW	AUG	-	-	-	-	-	-	-
2	1204			OWN	-	-	-	-	-	-	-
				PRE	-	-	-	-	-	-	-
C-F-1	V2 21204-012-5		ISI-21204-012	ISI	-	-	-	-	-	-	-
C5.11	21204-012-5		8" ELBOW TO PIPE	AUG	-	-	-	-	-	-	-
2	1204			OWN	-	-	-	-	-	-	-
				PRE	-	-	-	-	-	-	-
C-F-1	V2 21204-012-7	ISI/UT/	ISI-21204-012	ISI	-	-	-	-	-	s	-
C5.11	21204-012-7		8" PIPE TO ELBOW (AI 87-0131)	AUG	-	-	-	-	-	s	-
2	1204			OWN	-	-	-	-	-	-	-
				PRE	-	-	-	-	-	-	-
C-F-1	V2 21204-012-8		ISI-21204-012	ISI	-	-	-	-	-	-	-
C5.11	21204-012-8		8" ELBOW TO PIPE	AUG	-	-	-	-	-	-	-
2	1204			OWN	-	-	-	-	-	-	-
				PRE	-	-	-	-	-	-	-
C-F-1	V2 21204-012-9	ISI/UT/	ISI-21204-012	ISI	-	-	-	-	-	s	-
C5.11	21204-012-9		8" PIPE TO ELBOW (AI 87-0131)	AUG	-	-	-	-	-	s	-
2	1204			OWN	-	-	-	-	-	-	-
				PRE	-	-	-	-	-	-	-
C-F-1	V2 21204-020-1		ISI-21204-020	ISI	-	-	-	-	-	-	-
C5.11	21204-020-1		8" TEE TO PIPE	AUG	-	-	-	-	-	-	-
2	1204			OWN	-	-	-	-	-	-	-
				PRE	-	-	-	-	-	-	-
C-F-1	V2 21204-020-11		ISI-21204-020	ISI	-	-	-	-	-	-	-
C5.11	21204-020-11		8" PIPE TO PIPE	AUG	-	-	-	-	-	-	-
2	1204			OWN	-	-	-	-	-	-	-
				PRE	-	-	-	-	-	-	-
C-F-1	V2 21204-020-12		ISI-21204-020	ISI	-	-	-	-	-	-	-
C5.11	21204-020-12		8" PIPE TO ELBOW	AUG	-	-	-	-	-	-	-
2	1204			OWN	-	-	-	-	-	-	-
				PRE	-	-	-	-	-	-	-

Southern Nuclear Operating Company
3rd Interval
VOGTLE-2 ISI PLAN, VERSION 3.0

Category, Item No., Class	Summary No./CompID/System	Scope / Method / Procedure	Dwg/ISO No. Comp. Desc. Code Case		Period 1		Period 2		Period 3	
					2VR13	2VR14	2VR14A	2VR15	2VR16	2VR17
C-F-1 C5.11 2	V2 21204-020-13 21204-020-13 1204		ISI-21204-020 8" ELBOW TO PIPE	ISI AUG OWN PRE	-	-	-	-	-	-
C-F-1 C5.11 2	V2 21204-020-14 21204-020-14 1204		ISI-21204-020 8" PIPE TO ELBOW	ISI AUG OWN PRE	-	-	-	-	-	-
C-F-1 C5.11 2	V2 21204-020-15 21204-020-15 1204		ISI-21204-020 8" ELBOW TO PIPE	ISI AUG OWN PRE	-	-	-	-	-	-
C-F-1 C5.11 2	V2 21204-020-16 21204-020-16 1204		ISI-21204-020 8" PIPE TO ELBOW	ISI AUG OWN PRE	-	-	-	-	-	-
C-F-1 C5.11 2	V2 21204-020-17 21204-020-17 1204		ISI-21204-020 8" ELBOW TO PIPE	ISI AUG OWN PRE	-	-	-	-	-	-
C-F-1 C5.11 2	V2 21204-020-18 21204-020-18 1204		ISI-21204-020 8" PIPE TO ELBOW	ISI AUG OWN PRE	-	-	-	-	-	-
C-F-1 C5.11 2	V2 21204-020-19 21204-020-19 1204	ISI/UT/	ISI-21204-020 8" ELBOW TO PIPE (A1 87-0131)	ISI AUG OWN PRE	-	-	-	-	s	-
C-F-1 C5.11 2	V2 21204-020-2 21204-020-2 1204		ISI-21204-020 8" PIPE TO ELBOW	ISI AUG OWN PRE	-	-	-	-	-	-
C-F-1 C5.11 2	V2 21204-020-21 21204-020-21 1204		ISI-21204-020 8" PIPE TO ELBOW	ISI AUG OWN PRE	-	-	-	-	-	-
C-F-1 C5.11 2	V2 21204-020-22 21204-020-22 1204		ISI-21204-020 8" ELBOW TO PIPE	ISI AUG OWN PRE	-	-	-	-	-	-

Southern Nuclear Operating Company
3rd Interval
VOGTLE-2 ISI PLAN, VERSION 3.0

Category, Item No., Class	Summary No./ComplID/System	Scope / Method / Procedure	Dwg/ISO No. Comp. Desc. Code Case		Period 1		Period 2		Period 3	
					2VR13	2VR14	2VR14A	2VR15	2VR16	2VR17
C-F-1 C5.11 2	V2 21204-020-23 21204-020-23 1204		ISI-21204-020 8" PIPE TO ELBOW	ISI AUG OWN PRE	- - - -	- - - -	- - - -	- - - -	- - - -	- - - -
C-F-1 C5.11 2	V2 21204-020-24 21204-020-24 1204		ISI-21204-020 8" ELBOW TO PIPE	ISI AUG OWN PRE	- - - -	- - - -	- - - -	- - - -	- - - -	- - - -
C-F-1 C5.11 2	V2 21204-020-25 21204-020-25 1204		ISI-21204-020 8" PIPE TO ELBOW	ISI AUG OWN PRE	- - - -	- - - -	- - - -	- - - -	- - - -	- - - -
C-F-1 C5.11 2	V2 21204-020-26 21204-020-26 1204		ISI-21204-020 8" ELBOW TO PIPE	ISI AUG OWN PRE	- - - -	- - - -	- - - -	- - - -	- - - -	- - - -
C-F-1 C5.11 2	V2 21204-020-27 21204-020-27 1204		ISI-21204-020 8" PIPE TO VALVE	ISI AUG OWN PRE	- - - -	- - - -	- - - -	- - - -	- - - -	- - - -
C-F-1 C5.11 2	V2 21204-020-3 21204-020-3 1204		ISI-21204-020 8" ELBOW TO PIPE	ISI AUG OWN PRE	- - - -	- - - -	- - - -	- - - -	- - - -	- - - -
C-F-1 C5.11 2	V2 21204-020-4 21204-020-4 1204		ISI-21204-020 8" PIPE TO PIPE	ISI AUG OWN PRE	- - - -	- - - -	- - - -	- - - -	- - - -	- - - -
C-F-1 C5.11 2	V2 21204-020-5 21204-020-5 1204		ISI-21204-020 8" PIPE TO PIPE	ISI AUG OWN PRE	- - - -	- - - -	- - - -	- - - -	- - - -	- - - -
C-F-1 C5.11 2	V2 21204-020-6 21204-020-6 1204		ISI-21204-020 8" PIPE TO PIPE	ISI AUG OWN PRE	- - - -	- - - -	- - - -	- - - -	- - - -	- - - -
C-F-1 C5.11 2	V2 21204-020-8 21204-020-8 1204		ISI-21204-020 8" PIPE TO PIPE	ISI AUG OWN PRE	- - - -	- - - -	- - - -	- - - -	- - - -	- - - -

Southern Nuclear Operating Company
3rd Interval
VOGTLE-2 ISI PLAN, VERSION 3.0

Category, Item No., Class	Summary No./ComplID/System	Scope / Method / Procedure	Dwg/ISO No. Comp. Desc. Code Case	Period 1		Period 2		Period 3	
				2VR13	2VR14	2VR14A	2VR15	2VR16	2VR17
C-F-1 C5.11 2	V2 21204-020-9 21204-020-9 1204		ISI-21204-020 8" PIPE TO PIPE	ISI AUG OWN PRE	- - - -	- - - -	- - - -	- - - -	- - - -
C-F-1 C5.11 2	V2 21204-038-1 21204-038-1 1204		ISI-21204-038 14" BRANCH CONNECTION TO PIPE (AI 87-0131)	ISI AUG OWN PRE	- - - -	- - - -	- - - -	- - - -	- - - -
C-F-1 C5.11 2	V2 21204-038-10 21204-038-10 1204		ISI-21204-038 10" ELBOW TO PIPE	ISI AUG OWN PRE	- - - -	- - - -	- - - -	- - - -	- - - -
C-F-1 C5.11 2	V2 21204-038-12 21204-038-12 1204		ISI-21204-038 10" PIPE TO ELBOW	ISI AUG OWN PRE	- - - -	- - - -	- - - -	- - - -	- - - -
C-F-1 C5.11 2	V2 21204-038-13 21204-038-13 1204		ISI-21204-038 10" ELBOW TO PIPE	ISI AUG OWN PRE	- - - -	- - - -	- - - -	- - - -	- - - -
C-F-1 C5.11 2	V2 21204-038-14 21204-038-14 1204		ISI-21204-038 10" PIPE TO PIPE	ISI AUG OWN PRE	- - - -	- - - -	- - - -	- - - -	- - - -
C-F-1 C5.11 2	V2 21204-038-16 21204-038-16 1204		ISI-21204-038 10" PIPE TO ELBOW	ISI AUG OWN PRE	- - - -	- - - -	- - - -	- - - -	- - - -
C-F-1 C5.11 2	V2 21204-038-17 21204-038-17 1204	ISI/UT/	ISI-21204-038 10" ELBOW TO VALVE	ISI AUG OWN PRE	- - - -	- - - -	- - - -	- - - -	- - - -
C-F-1 C5.11 2	V2 21204-038-2 21204-038-2 1204		ISI-21204-038 14" PIPE TO ELBOW	ISI AUG OWN PRE	- - - -	- - - -	- - - -	- - - -	- - - -
C-F-1 C5.11 2	V2 21204-038-3 21204-038-3 1204		ISI-21204-038 14" ELBOW TO PIPE	ISI AUG OWN	- - -	- - -	- - -	- - -	- - -

Southern Nuclear Operating Company
3rd Interval
VOGTLE-2 ISI PLAN, VERSION 3.0

Category, Item No., Class	Summary No./ComplD/System	Scope / Method / Procedure	Dwg/ISO No. Comp. Desc. Code Case		Period 1		Period 2			Period 3	
					2VR13	2VR14	2VR14A	2VR15	2VR16	2VR17	2VR18
C-F-1	V2 21204-038-4		ISI-21204-038	PRE	-	-	-	-	-	-	-
C5.11	21204-038-4		14" PIPE TO PIPE	ISI	-	-	-	-	-	-	-
2	1204			AUG	-	-	-	-	-	-	-
				OWN	-	-	-	-	-	-	-
				PRE	-	-	-	-	-	-	-
C-F-1	V2 21204-038-5		ISI-21204-038	ISI	-	-	-	-	-	-	-
C5.11	21204-038-5		14" PIPE TO TEE	AUG	-	-	-	-	-	-	-
2	1204			OWN	-	-	-	-	-	-	-
				PRE	-	-	-	-	-	-	-
C-F-1	V2 21204-038-6		ISI-21204-038	ISI	-	-	-	-	-	-	-
C5.11	21204-038-6		14" TEE TO REDUCER	AUG	-	-	-	-	-	-	-
2	1204			OWN	-	-	-	-	-	-	-
				PRE	-	-	-	-	-	-	-
C-F-1	V2 21204-038-7		ISI-21204-038	ISI	-	-	-	-	-	-	-
C5.11	21204-038-7		10" TEE TO FLANGE	AUG	-	-	-	-	-	-	-
2	1204			OWN	-	-	-	-	-	-	-
				PRE	-	-	-	-	-	-	-
C-F-1	V2 21204-038-8		ISI-21204-038	ISI	-	-	-	-	-	-	-
C5.11	21204-038-8		10" FLANGE TO PIPE	AUG	-	-	-	-	-	-	-
2	1204			OWN	-	-	-	-	-	-	-
				PRE	-	-	-	-	-	-	-
C-F-1	V2 21204-038-8 A		ISI-21204-038	ISI	-	-	-	-	-	-	-
C5.11	21204-038-8 A		10" PIPE TO FLANGE	AUG	-	-	-	-	-	-	-
2	1204			OWN	-	-	-	-	-	-	-
				PRE	-	-	-	-	-	-	-
C-F-1	V2 21204-038-9		ISI-21204-038	ISI	-	-	-	-	-	-	-
C5.11	21204-038-9		10" FLANGE TO ELBOW	AUG	-	-	-	-	-	-	-
2	1204			OWN	-	-	-	-	-	-	-
				PRE	-	-	-	-	-	-	-
C-F-1	V2 21204-039-1		ISI-21204-039	ISI	-	-	-	-	-	-	-
C5.11	21204-039-1		8" VALVE TO PIPE	AUG	-	-	-	-	-	-	-
2	1204			OWN	-	-	-	-	-	-	-
				PRE	-	-	-	-	-	-	-
C-F-1	V2 21204-039-10		ISI-21204-039	ISI	-	-	-	-	-	-	-
C5.11	21204-039-10		8" ELBOW TO PIPE	AUG	-	-	-	-	-	-	-
2	1204			OWN	-	-	-	-	-	-	-
				PRE	-	-	-	-	-	-	-
C-F-1	V2 21204-039-11		ISI-21204-039	ISI	-	-	-	-	-	-	-
C5.11	21204-039-11		8" PIPE TO ELBOW	AUG	-	-	-	-	-	-	-
2	1204			OWN	-	-	-	-	-	-	-

Southern Nuclear Operating Company
3rd Interval
VOGTLE-2 ISI PLAN, VERSION 3.0

Category, Item No., Class	Summary No./ComplD/System	Scope / Method / Procedure	Dwg/ISO No. Comp. Desc. Code Case		Period 1		Period 2			Period 3	
					2VR13	2VR14	2VR14A	2VR15	2VR16	2VR17	2VR18
C-F-1	V2 21204-039-12		ISI-21204-039	PRE	-	-	-	-	-	-	-
C5.11	21204-039-12		8" ELBOW TO PIPE	ISI	-	-	-	-	-	-	-
2	1204			AUG	-	-	-	-	-	-	-
				OWN	-	-	-	-	-	-	-
				PRE	-	-	-	-	-	-	-
C-F-1	V2 21204-039-13		ISI-21204-039	ISI	-	-	-	-	-	-	-
C5.11	21204-039-13		8" PIPE TO TEE	AUG	-	-	-	-	-	-	-
2	1204			OWN	-	-	-	-	-	-	-
				PRE	-	-	-	-	-	-	-
C-F-1	V2 21204-039-14		ISI-21204-039	ISI	-	-	-	-	-	-	-
C5.11	21204-039-14		8" TEE TO PIPE	AUG	-	-	-	-	-	-	-
2	1204			OWN	-	-	-	-	-	-	-
				PRE	-	-	-	-	-	-	-
C-F-1	V2 21204-039-15		ISI-21204-039	ISI	-	-	-	-	-	-	-
C5.11	21204-039-15		8" PIPE TO REDUCER	AUG	-	-	-	-	-	-	-
2	1204			OWN	-	-	-	-	-	-	-
				PRE	-	-	-	-	-	-	-
C-F-1	V2 21204-039-16		ISI-21204-039	ISI	-	-	-	-	-	-	-
C5.11	21204-039-16		6" REDUCER TO PIPE	AUG	-	-	-	-	-	-	-
2	1204			OWN	-	-	-	-	-	-	-
				PRE	-	-	-	-	-	-	-
C-F-1	V2 21204-039-17		ISI-21204-039	ISI	-	-	-	-	-	-	-
C5.11	21204-039-17		6" PIPE TO ELBOW	AUG	-	-	-	-	-	-	-
2	1204			OWN	-	-	-	-	-	-	-
				PRE	-	-	-	-	-	-	-
C-F-1	V2 21204-039-18		ISI-21204-039	ISI	-	-	-	-	-	-	-
C5.11	21204-039-18		6" ELBOW TO PIPE	AUG	-	-	-	-	-	-	-
2	1204			OWN	-	-	-	-	-	-	-
				PRE	-	-	-	-	-	-	-
C-F-1	V2 21204-039-19		ISI-21204-039	ISI	-	-	-	-	-	-	-
C5.11	21204-039-19		6" PIPE TO ELBOW	AUG	-	-	-	-	-	-	-
2	1204			OWN	-	-	-	-	-	-	-
				PRE	-	-	-	-	-	-	-
C-F-1	V2 21204-039-2		ISI-21204-039	ISI	-	-	-	-	-	-	-
C5.11	21204-039-2		8" PIPE TO TRIM ELL	AUG	-	-	-	-	-	-	-
2	1204			OWN	-	-	-	-	-	-	-
				PRE	-	-	-	-	-	-	-
C-F-1	V2 21204-039-20		ISI-21204-039	ISI	-	-	-	-	-	-	-
C5.11	21204-039-20		6" ELBOW TO PIPE	AUG	-	-	-	-	-	-	-
2	1204			OWN	-	-	-	-	-	-	-

Southern Nuclear Operating Company
3rd Interval
VOGTLE-2 ISI PLAN, VERSION 3.0

Category, Item No., Class	Summary No./ComplD/System	Scope / Method / Procedure	Dwg/ISO No. Comp. Desc. Code Case		Period 1		Period 2		Period 3	
					2VR13	2VR14	2VR14A	2VR15	2VR16	2VR17
C-F-1	V2 21204-039-21		ISI-21204-039	PRE	-	-	-	-	-	-
C5.11	21204-039-21		6" PIPE TO PIPE	ISI	-	-	-	-	-	-
2	1204			AUG	-	-	-	-	-	-
				OWN	-	-	-	-	-	-
				PRE	-	-	-	-	-	-
C-F-1	V2 21204-039-22		ISI-21204-039	ISI	-	-	-	-	-	-
C5.11	21204-039-22		6" PIPE TO ELBOW	AUG	-	-	-	-	-	-
2	1204			OWN	-	-	-	-	-	-
				PRE	-	-	-	-	-	-
C-F-1	V2 21204-039-23		ISI-21204-039	ISI	-	-	-	-	-	-
C5.11	21204-039-23		6" ELBOW TO PIPE	AUG	-	-	-	-	-	-
2	1204			OWN	-	-	-	-	-	-
				PRE	-	-	-	-	-	-
C-F-1	V2 21204-039-24		ISI-21204-039	ISI	-	-	-	-	-	-
C5.11	21204-039-24		6" PIPE TO FLANGE	AUG	-	-	-	-	-	-
2	1204			OWN	-	-	-	-	-	-
				PRE	-	-	-	-	-	-
C-F-1	V2 21204-039-25		ISI-21204-039	ISI	-	-	-	-	-	-
C5.11	21204-039-25		6" FLANGE TO PIPE	AUG	-	-	-	-	-	-
2	1204			OWN	-	-	-	-	-	-
				PRE	-	-	-	-	-	-
C-F-1	V2 21204-039-26		ISI-21204-039	ISI	-	-	-	-	-	-
C5.11	21204-039-26		6" PIPE TO ELBOW	AUG	-	-	-	-	-	-
2	1204			OWN	-	-	-	-	-	-
				PRE	-	-	-	-	-	-
C-F-1	V2 21204-039-27		ISI-21204-039	ISI	-	-	-	-	-	-
C5.11	21204-039-27		6" ELBOW TO PIPE	AUG	-	-	-	-	-	-
2	1204			OWN	-	-	-	-	-	-
				PRE	-	-	-	-	-	-
C-F-1	V2 21204-039-28		ISI-21204-039	ISI	-	-	-	-	-	-
C5.11	21204-039-28		6" PIPE TO ELBOW	AUG	-	-	-	-	-	-
2	1204			OWN	-	-	-	-	-	-
				PRE	-	-	-	-	-	-
C-F-1	V2 21204-039-29		ISI-21204-039	ISI	-	-	-	-	-	-
C5.11	21204-039-29		6" ELBOW TO PIPE	AUG	-	-	-	-	-	-
2	1204			OWN	-	-	-	-	-	-
				PRE	-	-	-	-	-	-
C-F-1	V2 21204-039-3		ISI-21204-039	ISI	-	-	-	-	-	-
C5.11	21204-039-3		8" TRIM ELL TO PIPE	AUG	-	-	-	-	-	-
2	1204			OWN	-	-	-	-	-	-

Southern Nuclear Operating Company
3rd Interval
VOGTLE-2 ISI PLAN, VERSION 3.0

Category, Item No., Class	Summary No./ComplID/System	Scope / Method / Procedure	Dwg/ISO No. Comp. Desc. Code Case		Period 1		Period 2		Period 3			
					2VR13	2VR14	2VR14A	2VR15	2VR16	2VR17	2VR18	
C-F-1 C5.11 2	V2 21204-039-30 21204-039-30 1204		ISI-21204-039 6" PIPE TO ELBOW	PRE ISI AUG OWN PRE	-	-	-	-	-	-	-	-
C-F-1 C5.11 2	V2 21204-039-31 21204-039-31 1204		ISI-21204-039 6" ELBOW TO PIPE	ISI AUG OWN PRE	-	-	-	-	-	-	-	-
C-F-1 C5.11 2	V2 21204-039-33 21204-039-33 1204		ISI-21204-039 6" PIPE TO ELBOW	ISI AUG OWN PRE	-	-	-	-	-	-	-	-
C-F-1 C5.11 2	V2 21204-039-34 21204-039-34 1204		ISI-21204-039 6" ELBOW TO PIPE	ISI AUG OWN PRE	-	-	-	-	-	-	-	-
C-F-1 C5.11 2	V2 21204-039-35 21204-039-35 1204	ISI/UT/	ISI-21204-039 6" PIPE TO ELBOW (AI 87-0131)	ISI AUG OWN PRE	-	-	-	s	-	-	-	-
C-F-1 C5.11 2	V2 21204-039-36 21204-039-36 1204		ISI-21204-039 6" ELBOW TO PIPE	ISI AUG OWN PRE	-	-	-	-	-	-	-	-
C-F-1 C5.11 2	V2 21204-039-37 21204-039-37 1204		ISI-21204-039 6" PIPE TO VALVE	ISI AUG OWN PRE	-	-	-	-	-	-	-	-
C-F-1 C5.11 2	V2 21204-039-38 21204-039-38 1204		ISI-21204-039 8" TEE TO PIPE	ISI AUG OWN PRE	-	-	-	-	-	-	-	-
C-F-1 C5.11 2	V2 21204-039-39 21204-039-39 1204		ISI-21204-039 8" PIPE TO REDUCER	ISI AUG OWN PRE	-	-	-	-	-	-	-	-
C-F-1 C5.11 2	V2 21204-039-4 21204-039-4 1204		ISI-21204-039 8" PIPE TO PIPE	ISI AUG OWN	-	-	-	-	-	-	-	-

Southern Nuclear Operating Company
3rd Interval
VOGTLE-2 ISI PLAN, VERSION 3.0

Category, Item No., Class	Summary No./ComplD/System	Scope / Method / Procedure	Dwg/ISO No. Comp. Desc. Code Case	PRE	Period 1		Period 2			Period 3	
					2VR13	2VR14	2VR14A	2VR15	2VR16	2VR17	2VR18
C-F-1 C5.11 2	V2 21204-039-40 21204-039-40 1204		ISI-21204-039 6" REDUCER TO PIPE	ISI AUG OWN PRE	- - - -	- - - -	- - - -	- - - -	- - - -	- - - -	- - - -
C-F-1 C5.11 2	V2 21204-039-41 21204-039-41 1204		ISI-21204-039 6" PIPE TO ELBOW	ISI AUG OWN PRE	- - - -	- - - -	- - - -	- - - -	- - - -	- - - -	- - - -
C-F-1 C5.11 2	V2 21204-039-42 21204-039-42 1204		ISI-21204-039 6" ELBOW TO PIPE	ISI AUG OWN PRE	- - - -	- - - -	- - - -	- - - -	- - - -	- - - -	- - - -
C-F-1 C5.11 2	V2 21204-039-43 21204-039-43 1204		ISI-21204-039 6" PIPE TO ELBOW	ISI AUG OWN PRE	- - - -	- - - -	- - - -	- - - -	- - - -	- - - -	- - - -
C-F-1 C5.11 2	V2 21204-039-44 21204-039-44 1204		ISI-21204-039 6" ELBOW TO PIPE	ISI AUG OWN PRE	- - - -	- - - -	- - - -	- - - -	- - - -	- - - -	- - - -
C-F-1 C5.11 2	V2 21204-039-45 21204-039-45 1204		ISI-21204-039 6" PIPE TO PIPE	ISI AUG OWN PRE	- - - -	- - - -	- - - -	- - - -	- - - -	- - - -	- - - -
C-F-1 C5.11 2	V2 21204-039-46 21204-039-46 1204		ISI-21204-039 6" PIPE TO PIPE	ISI AUG OWN PRE	- - - -	- - - -	- - - -	- - - -	- - - -	- - - -	- - - -
C-F-1 C5.11 2	V2 21204-039-47 21204-039-47 1204		ISI-21204-039 6" PIPE TO ELBOW	ISI AUG OWN PRE	- - - -	- - - -	- - - -	- - - -	- - - -	- - - -	- - - -
C-F-1 C5.11 2	V2 21204-039-48 21204-039-48 1204		ISI-21204-039 6" ELBOW TO PIPE	ISI AUG OWN PRE	- - - -	- - - -	- - - -	- - - -	- - - -	- - - -	- - - -
C-F-1 C5.11 2	V2 21204-039-49 21204-039-49 1204		ISI-21204-039 6" PIPE TO ELBOW	ISI AUG OWN	- - -	- - -	- - -	- - -	- - -	- - -	- - -

Southern Nuclear Operating Company
3rd Interval
VOGTLE-2 ISI PLAN, VERSION 3.0

Category, Item No., Class	Summary No./ComplID/System	Scope / Method / Procedure	Dwg/ISO No. Comp. Desc. Code Case		Period 1		Period 2			Period 3	
					2VR13	2VR14	2VR14A	2VR15	2VR16	2VR17	2VR18
C-F-1 C5.11 2	V2 21204-039-5 21204-039-5 1204		ISI-21204-039 8" PIPE TO PENETRATION	PRE ISI AUG OWN PRE	-	-	-	-	-	-	-
C-F-1 C5.11 2	V2 21204-039-50 21204-039-50 1204		ISI-21204-039 6" ELBOW TO PIPE	ISI AUG OWN PRE	-	-	-	-	-	-	-
C-F-1 C5.11 2	V2 21204-039-52 21204-039-52 1204		ISI-21204-039 6" PIPE TO ELBOW	ISI AUG OWN PRE	-	-	-	-	-	-	-
C-F-1 C5.11 2	V2 21204-039-53 21204-039-53 1204		ISI-21204-039 6" ELBOW TO PIPE	ISI AUG OWN PRE	-	-	-	-	-	-	-
C-F-1 C5.11 2	V2 21204-039-54 21204-039-54 1204		ISI-21204-039 6" PIPE TO ELBOW	ISI AUG OWN PRE	-	-	-	-	-	-	-
C-F-1 C5.11 2	V2 21204-039-55 21204-039-55 1204		ISI-21204-039 6" ELBOW TO PIPE	ISI AUG OWN PRE	-	-	-	-	-	-	-
C-F-1 C5.11 2	V2 21204-039-56 21204-039-56 1204		ISI-21204-039 6" PIPE TO FLANGE	ISI AUG OWN PRE	-	-	-	-	-	-	-
C-F-1 C5.11 2	V2 21204-039-57 21204-039-57 1204		ISI-21204-039 6" FLANGE TO PIPE	ISI AUG OWN PRE	-	-	-	-	-	-	-
C-F-1 C5.11 2	V2 21204-039-58 21204-039-58 1204		ISI-21204-039 6" PIPE TO VALVE	ISI AUG OWN PRE	-	-	-	-	-	-	-
C-F-1 C5.11 2	V2 21204-039-6 21204-039-6 1204		ISI-21204-039 8" PENETRATION TO PIPE	ISI AUG OWN	-	-	-	-	-	-	-

Southern Nuclear Operating Company
3rd Interval
VOGTLE-2 ISI PLAN, VERSION 3.0

Category, Item No., Class	Summary No./ComplD/System	Scope / Method / Procedure	Dwg/ISO No. Comp. Desc. Code Case		Period 1		Period 2		Period 3	
					2VR13	2VR14	2VR14A	2VR15	2VR16	2VR17
C-F-1	V2 21204-039-7		ISI-21204-039	PRE	-	-	-	-	-	-
C5.11	21204-039-7		8" PIPE TO PIPE	ISI	-	-	-	-	-	-
2	1204			AUG	-	-	-	-	-	-
				OWN	-	-	-	-	-	-
				PRE	-	-	-	-	-	-
C-F-1	V2 21204-039-8		ISI-21204-039	ISI	-	-	-	-	-	-
C5.11	21204-039-8		8" PIPE TO PIPE	AUG	-	-	-	-	-	-
2	1204			OWN	-	-	-	-	-	-
				PRE	-	-	-	-	-	-
C-F-1	V2 21204-039-9		ISI-21204-039	ISI	-	-	-	-	-	-
C5.11	21204-039-9		8" PIPE TO ELBOW	AUG	-	-	-	-	-	-
2	1204			OWN	-	-	-	-	-	-
				PRE	-	-	-	-	-	-
C-F-1	V2 21204-041-1		ISI-21204-041	ISI	-	-	-	-	-	-
C5.11	21204-041-1		8" VALVE TO PIPE	AUG	-	-	-	-	-	-
2	1204			OWN	-	-	-	-	-	-
				PRE	-	-	-	-	-	-
C-F-1	V2 21204-041-10		ISI-21204-041	ISI	-	-	-	-	-	-
C5.11	21204-041-10		8" PIPE TO REDUCER	AUG	-	-	-	-	-	-
2	1204			OWN	-	-	-	-	-	-
				PRE	-	-	-	-	-	-
C-F-1	V2 21204-041-11		ISI-21204-041	ISI	-	-	-	-	-	-
C5.11	21204-041-11		6" REDUCER TO PIPE	AUG	-	-	-	-	-	-
2	1204			OWN	-	-	-	-	-	-
				PRE	-	-	-	-	-	-
C-F-1	V2 21204-041-12		ISI-21204-041	ISI	-	-	-	-	-	-
C5.11	21204-041-12		6" PIPE TO ELBOW	AUG	-	-	-	-	-	-
2	1204			OWN	-	-	-	-	-	-
				PRE	-	-	-	-	-	-
C-F-1	V2 21204-041-13		ISI-21204-041	ISI	-	-	-	-	-	-
C5.11	21204-041-13		6" ELBOW TO PIPE	AUG	-	-	-	-	-	-
2	1204			OWN	-	-	-	-	-	-
				PRE	-	-	-	-	-	-
C-F-1	V2 21204-041-14		ISI-21204-041	ISI	-	-	-	-	-	-
C5.11	21204-041-14		6" PIPE TO ELBOW	AUG	-	-	-	-	-	-
2	1204			OWN	-	-	-	-	-	-
				PRE	-	-	-	-	-	-
C-F-1	V2 21204-041-15		ISI-21204-041	ISI	-	-	-	-	-	-
C5.11	21204-041-15		6" ELBOW TO PIPE	AUG	-	-	-	-	-	-
2	1204			OWN	-	-	-	-	-	-

Southern Nuclear Operating Company
3rd Interval
VOGTLE-2 ISI PLAN, VERSION 3.0

Category, Item No., Class	Summary No./CompID/System	Scope / Method / Procedure	Dwg/ISO No. Comp. Desc. Code Case		Period 1		Period 2			Period 3	
					2VR13	2VR14	2VR14A	2VR15	2VR16	2VR17	2VR18
				PRE	-	-	-	-	-	-	-
C-F-1	V2 21204-041-16		ISI-21204-041	ISI	-	-	-	-	-	-	-
C5.11	21204-041-16		6" PIPE TO PIPE	AUG	-	-	-	-	-	-	-
2	1204			OWN	-	-	-	-	-	-	-
				PRE	-	-	-	-	-	-	-
C-F-1	V2 21204-041-17		ISI-21204-041	ISI	-	-	-	-	-	-	-
C5.11	21204-041-17		6" PIPE TO PIPE	AUG	-	-	-	-	-	-	-
2	1204			OWN	-	-	-	-	-	-	-
				PRE	-	-	-	-	-	-	-
C-F-1	V2 21204-041-18		ISI-21204-041	ISI	-	-	-	-	-	-	-
C5.11	21204-041-18		6" PIPE TO ELBOW	AUG	-	-	-	-	-	-	-
2	1204			OWN	-	-	-	-	-	-	-
				PRE	-	-	-	-	-	-	-
C-F-1	V2 21204-041-19		ISI-21204-041	ISI	-	-	-	-	-	-	-
C5.11	21204-041-19		6" ELBOW TO PIPE	AUG	-	-	-	-	-	-	-
2	1204			OWN	-	-	-	-	-	-	-
				PRE	-	-	-	-	-	-	-
C-F-1	V2 21204-041-2		ISI-21204-041	ISI	-	-	-	-	-	-	-
C5.11	21204-041-2		8" PIPE TO PIPE	AUG	-	-	-	-	-	-	-
2	1204			OWN	-	-	-	-	-	-	-
				PRE	-	-	-	-	-	-	-
C-F-1	V2 21204-041-20		ISI-21204-041	ISI	-	-	-	-	-	-	-
C5.11	21204-041-20		6" PIPE TO ELBOW	AUG	-	-	-	-	-	-	-
2	1204			OWN	-	-	-	-	-	-	-
				PRE	-	-	-	-	-	-	-
C-F-1	V2 21204-041-21		ISI-21204-041	ISI	-	-	-	-	-	-	-
C5.11	21204-041-21		6" ELBOW TO PIPE	AUG	-	-	-	-	-	-	-
2	1204			OWN	-	-	-	-	-	-	-
				PRE	-	-	-	-	-	-	-
C-F-1	V2 21204-041-22		ISI-21204-041	ISI	-	-	-	-	-	-	-
C5.11	21204-041-22		6" PIPE TO ELBOW	AUG	-	-	-	-	-	-	-
2	1204			OWN	-	-	-	-	-	-	-
				PRE	-	-	-	-	-	-	-
C-F-1	V2 21204-041-23		ISI-21204-041	ISI	-	-	-	-	-	-	-
C5.11	21204-041-23		6" ELBOW TO PIPE	AUG	-	-	-	-	-	-	-
2	1204			OWN	-	-	-	-	-	-	-
				PRE	-	-	-	-	-	-	-
C-F-1	V2 21204-041-24		ISI-21204-041	ISI	-	-	-	-	-	-	-
C5.11	21204-041-24		6" PIPE TO FLANGE	AUG	-	-	-	-	-	-	-
2	1204			OWN	-	-	-	-	-	-	-

Southern Nuclear Operating Company
3rd Interval
VOGTLE-2 ISI PLAN, VERSION 3.0

Category, Item No., Class	Summary No./ComplD/System	Scope / Method / Procedure	Dwg/ISO No. Comp. Desc. Code Case		Period 1		Period 2			Period 3	
					2VR13	2VR14	2VR14A	2VR15	2VR16	2VR17	2VR18
C-F-1	V2 21204-041-25		ISI-21204-041	ISI	-	-	-	-	-	-	-
C5.11	21204-041-25		6" FLANGE TO PIPE	AUG	-	-	-	-	-	-	-
2	1204			OWN	-	-	-	-	-	-	-
				PRE	-	-	-	-	-	-	-
C-F-1	V2 21204-041-26		ISI-21204-041	ISI	-	-	-	-	-	-	-
C5.11	21204-041-26		6" PIPE TO ELBOW	AUG	-	-	-	-	-	-	-
2	1204			OWN	-	-	-	-	-	-	-
				PRE	-	-	-	-	-	-	-
C-F-1	V2 21204-041-27		ISI-21204-041	ISI	-	-	-	-	-	-	-
C5.11	21204-041-27		6" ELBOW TO PIPE	AUG	-	-	-	-	-	-	-
2	1204			OWN	-	-	-	-	-	-	-
				PRE	-	-	-	-	-	-	-
C-F-1	V2 21204-041-28		ISI-21204-041	ISI	-	-	-	-	-	-	-
C5.11	21204-041-28		6" PIPE TO ELBOW	AUG	-	-	-	-	-	-	-
2	1204			OWN	-	-	-	-	-	-	-
				PRE	-	-	-	-	-	-	-
C-F-1	V2 21204-041-29	ISI/UT/	ISI-21204-041	ISI	-	-	-	-	-	s	-
C5.11	21204-041-29		6" ELBOW TO PIPE (AI 87-0131)	AUG	-	-	-	-	-	-	-
2	1204			OWN	-	-	-	-	-	-	-
				PRE	-	-	-	-	-	-	-
C-F-1	V2 21204-041-3		ISI-21204-041	ISI	-	-	-	-	-	-	-
C5.11	21204-041-3		8" PIPE TO PENETRATION	AUG	-	-	-	-	-	-	-
2	1204			OWN	-	-	-	-	-	-	-
				PRE	-	-	-	-	-	-	-
C-F-1	V2 21204-041-30		ISI-21204-041	ISI	-	-	-	-	-	-	-
C5.11	21204-041-30		6" PIPE TO ELBOW	AUG	-	-	-	-	-	-	-
2	1204			OWN	-	-	-	-	-	-	-
				PRE	-	-	-	-	-	-	-
C-F-1	V2 21204-041-31		ISI-21204-041	ISI	-	-	-	-	-	-	-
C5.11	21204-041-31		6" ELBOW TO PIPE	AUG	-	-	-	-	-	-	-
2	1204			OWN	-	-	-	-	-	-	-
				PRE	-	-	-	-	-	-	-
C-F-1	V2 21204-041-32		ISI-21204-041	ISI	-	-	-	-	-	-	-
C5.11	21204-041-32		6" PIPE TO ELBOW	AUG	-	-	-	-	-	-	-
2	1204			OWN	-	-	-	-	-	-	-
				PRE	-	-	-	-	-	-	-
C-F-1	V2 21204-041-33		ISI-21204-041	ISI	-	-	-	-	-	-	-
C5.11	21204-041-33		6" ELBOW TO PIPE	AUG	-	-	-	-	-	-	-
2	1204			OWN	-	-	-	-	-	-	-

Southern Nuclear Operating Company
3rd Interval
VOGTLE-2 ISI PLAN, VERSION 3.0

Category, Item No., Class	Summary No./ComplID/System	Scope / Method / Procedure	Dwg/ISO No. Comp. Desc. Code Case		Period 1		Period 2			Period 3	
					2VR13	2VR14	2VR14A	2VR15	2VR16	2VR17	2VR18
C-F-1	V2 21204-041-35		ISI-21204-041	ISI	-	-	-	-	-	-	-
C5.11	21204-041-35		6" PIPE TO ELBOW	AUG	-	-	-	-	-	-	-
2	1204			OWN	-	-	-	-	-	-	-
				PRE	-	-	-	-	-	-	-
C-F-1	V2 21204-041-36		ISI-21204-041	ISI	-	-	-	-	-	-	-
C5.11	21204-041-36		6" ELBOW TO PIPE	AUG	-	-	-	-	-	-	-
2	1204			OWN	-	-	-	-	-	-	-
				PRE	-	-	-	-	-	-	-
C-F-1	V2 21204-041-37		ISI-21204-041	ISI	-	-	-	-	-	-	-
C5.11	21204-041-37		6" PIPE TO VALVE	AUG	-	-	-	-	-	-	-
2	1204			OWN	-	-	-	-	-	-	-
				PRE	-	-	-	-	-	-	-
C-F-1	V2 21204-041-38		ISI-21204-041	ISI	-	-	-	-	-	-	-
C5.11	21204-041-38		6" TEE TO PIPE	AUG	-	-	-	-	-	-	-
2	1204			OWN	-	-	-	-	-	-	-
				PRE	-	-	-	-	-	-	-
C-F-1	V2 21204-041-39	ISI/UT/	ISI-21204-041	ISI	-	-	-	-	-	s	-
C5.11	21204-041-39		6" PIPE TO ELBOW (AI 87-0131)	AUG	-	-	-	-	-	-	-
2	1204			OWN	-	-	-	-	-	-	-
				PRE	-	-	-	-	-	-	-
C-F-1	V2 21204-041-4		ISI-21204-041	ISI	-	-	-	-	-	-	-
C5.11	21204-041-4		8" PENETRATION TO PIPE	AUG	-	-	-	-	-	-	-
2	1204			OWN	-	-	-	-	-	-	-
				PRE	-	-	-	-	-	-	-
C-F-1	V2 21204-041-40		ISI-21204-041	ISI	-	-	-	-	-	-	-
C5.11	21204-041-40		6" ELBOW TO PIPE	AUG	-	-	-	-	-	-	-
2	1204			OWN	-	-	-	-	-	-	-
				PRE	-	-	-	-	-	-	-
C-F-1	V2 21204-041-41		ISI-21204-041	ISI	-	-	-	-	-	-	-
C5.11	21204-041-41		6" PIPE TO ELBOW	AUG	-	-	-	-	-	-	-
2	1204			OWN	-	-	-	-	-	-	-
				PRE	-	-	-	-	-	-	-
C-F-1	V2 21204-041-42		ISI-21204-041	ISI	-	-	-	-	-	-	-
C5.11	21204-041-42		6" ELBOW TO PIPE	AUG	-	-	-	-	-	-	-
2	1204			OWN	-	-	-	-	-	-	-
				PRE	-	-	-	-	-	-	-
C-F-1	V2 21204-041-43		ISI-21204-041	ISI	-	-	-	-	-	-	-
C5.11	21204-041-43		6" PIPE TO ELBOW	AUG	-	-	-	-	-	-	-
2	1204			OWN	-	-	-	-	-	-	-

Southern Nuclear Operating Company
3rd Interval
VOGTLE-2 ISI PLAN, VERSION 3.0

Category, Item No., Class	Summary No./ComplD/System	Scope / Method / Procedure	Dwg/ISO No. Comp. Desc. Code Case	PRE	Period 1		Period 2			Period 3	
					2VR13	2VR14	2VR14A	2VR15	2VR16	2VR17	2VR18
C-F-1 C5.11 2	V2 21204-041-44 21204-041-44 1204		ISI-21204-041 6" ELBOW TO PIPE	ISI AUG OWN PRE	-	-	-	-	-	-	-
C-F-1 C5.11 2	V2 21204-041-45 21204-041-45 1204		ISI-21204-041 6" PIPE TO ELBOW	ISI AUG OWN PRE	-	-	-	-	-	-	-
C-F-1 C5.11 2	V2 21204-041-46 21204-041-46 1204		ISI-21204-041 6" ELBOW TO PIPE	ISI AUG OWN PRE	-	-	-	-	-	-	-
C-F-1 C5.11 2	V2 21204-041-47 21204-041-47 1204		ISI-21204-041 6" PIPE TO ELBOW	ISI AUG OWN PRE	-	-	-	-	-	-	-
C-F-1 C5.11 2	V2 21204-041-48 21204-041-48 1204		ISI-21204-041 6" ELBOW TO PIPE	ISI AUG OWN PRE	-	-	-	-	-	-	-
C-F-1 C5.11 2	V2 21204-041-49 21204-041-49 1204		ISI-21204-041 6" PIPE TO FLANGE	ISI AUG OWN PRE	-	-	-	-	-	-	-
C-F-1 C5.11 2	V2 21204-041-5 21204-041-5 1204		ISI-21204-041 8" PIPE TO PIPE	ISI AUG OWN PRE	-	-	-	-	-	-	-
C-F-1 C5.11 2	V2 21204-041-50 21204-041-50 1204		ISI-21204-041 6" FLANGE TO PIPE	ISI AUG OWN PRE	-	-	-	-	-	-	-
C-F-1 C5.11 2	V2 21204-041-52 21204-041-52 1204		ISI-21204-041 6" PIPE TO VALVE	ISI AUG OWN PRE	-	-	-	-	-	-	-
C-F-1 C5.11 2	V2 21204-041-6 21204-041-6 1204		ISI-21204-041 8" PIPE TO ELBOW	ISI AUG OWN	-	-	-	-	-	-	-

Southern Nuclear Operating Company
3rd Interval
VOGTLE-2 ISI PLAN, VERSION 3.0

Category, Item No., Class	Summary No./ComplD/System	Scope / Method / Procedure	Dwg/ISO No. Comp. Desc. Code Case	PRE	Period 1		Period 2			Period 3	
					2VR13	2VR14	2VR14A	2VR15	2VR16	2VR17	2VR18
C-F-1 C5.11 2	V2 21204-041-7 21204-041-7 1204		ISI-21204-041 8" ELBOW TO PIPE	ISI AUG OWN PRE	- - - -	- - - -	- - - -	- - - -	- - - -	- - - -	- - - -
C-F-1 C5.11 2	V2 21204-041-8 21204-041-8 1204		ISI-21204-041 8" PIPE TO TEE	ISI AUG OWN PRE	- - - -	- - - -	- - - -	- - - -	- - - -	- - - -	- - - -
C-F-1 C5.11 2	V2 21204-041-9 21204-041-9 1204		ISI-21204-041 8" TEE TO PIPE (AI 87-0131)	ISI AUG OWN PRE	- - - -	- - - -	- - - -	- - - -	- - - -	- - - -	- - - -
C-F-1 C5.11 2	V2 21204-120-1 21204-120-1 1204		ISI-21204-120 10" SAFE END TO PIPE	ISI AUG OWN PRE	- - - -	- - - -	- - - -	- - - -	- - - -	- - - -	- - - -
C-F-1 C5.11 2	V2 21204-120-2 21204-120-2 1204		ISI-21204-120 10" PIPE TO ELBOW	ISI AUG OWN PRE	- - - -	- - - -	- - - -	- - - -	- - - -	- - - -	- - - -
C-F-1 C5.11 2	V2 21204-120-3 21204-120-3 1204		ISI-21204-120 10" ELBOW TO PIPE	ISI AUG OWN PRE	- - - -	- - - -	- - - -	- - - -	- - - -	- - - -	- - - -
C-F-1 C5.11 2	V2 21204-120-4 21204-120-4 1204		ISI-21204-120 10" PIPE TO ELBOW	ISI AUG OWN PRE	- - - -	- - - -	- - - -	- - - -	- - - -	- - - -	- - - -
C-F-1 C5.11 2	V2 21204-120-5 21204-120-5 1204	ISI/UT/	ISI-21204-120 10" ELBOW TO PIPE (AI 87-0131)	ISI AUG OWN PRE	- - - -	- - - -	- - - -	s - - -	- - - -	- - - -	- - - -
C-F-1 C5.11 2	V2 21204-120-6 21204-120-6 1204		ISI-21204-120 10" PIPE TO VALVE	ISI AUG OWN PRE	- - - -	- - - -	- - - -	- - - -	- - - -	- - - -	- - - -
C-F-1 C5.11 2	V2 21204-121-1 21204-121-1 1204	ISI/UT/	ISI-21204-121 10" SAFE END TO PIPE (AI 87-0131)	ISI AUG OWN	- - -	- - -	- - -	s - -	- - -	- - -	- - -

Southern Nuclear Operating Company
3rd Interval
VOGTLE-2 ISI PLAN, VERSION 3.0

Category, Item No., Class	Summary No./ComplID/System	Scope / Method / Procedure	Dwg/ISO No. Comp. Desc. Code Case		Period 1		Period 2			Period 3	
					2VR13	2VR14	2VR14A	2VR15	2VR16	2VR17	2VR18
C-F-1	V2 21204-121-2		ISI-21204-121	PRE	-	-	-	-	-	-	-
C5.11	21204-121-2		10" PIPE TO ELBOW	ISI	-	-	-	-	-	-	-
2	1204			AUG	-	-	-	-	-	-	-
				OWN	-	-	-	-	-	-	-
				PRE	-	-	-	-	-	-	-
C-F-1	V2 21204-121-3		ISI-21204-121	ISI	-	-	-	-	-	-	-
C5.11	21204-121-3		10" ELBOW TO PIPE	AUG	-	-	-	-	-	-	-
2	1204			OWN	-	-	-	-	-	-	-
				PRE	-	-	-	-	-	-	-
C-F-1	V2 21204-121-4		ISI-21204-121	ISI	-	-	-	-	-	-	-
C5.11	21204-121-4		10" PIPE TO ELBOW	AUG	-	-	-	-	-	-	-
2	1204			OWN	-	-	-	-	-	-	-
				PRE	-	-	-	-	-	-	-
C-F-1	V2 21204-121-5		ISI-21204-121	ISI	-	-	-	-	-	-	-
C5.11	21204-121-5		10" ELBOW TO PIPE	AUG	-	-	-	-	-	-	-
2	1204			OWN	-	-	-	-	-	-	-
				PRE	-	-	-	-	-	-	-
C-F-1	V2 21204-121-6		ISI-21204-121	ISI	-	-	-	-	-	-	-
C5.11	21204-121-6		10" PIPE TO VALVE	AUG	-	-	-	-	-	-	-
2	1204			OWN	-	-	-	-	-	-	-
				PRE	-	-	-	-	-	-	-
C-F-1	V2 21204-122-1		ISI-21204-122	ISI	-	-	-	-	-	-	-
C5.11	21204-122-1		10" SAFE END TO PIPE	AUG	-	-	-	-	-	-	-
2	1204			OWN	-	-	-	-	-	-	-
				PRE	-	-	-	-	-	-	-
C-F-1	V2 21204-122-2		ISI-21204-122	ISI	-	-	-	-	-	-	-
C5.11	21204-122-2		10" PIPE TO ELBOW	AUG	-	-	-	-	-	-	-
2	1204			OWN	-	-	-	-	-	-	-
				PRE	-	-	-	-	-	-	-
C-F-1	V2 21204-122-3		ISI-21204-122	ISI	-	-	-	-	-	-	-
C5.11	21204-122-3		10" ELBOW TO PIPE	AUG	-	-	-	-	-	-	-
2	1204			OWN	-	-	-	-	-	-	-
				PRE	-	-	-	-	-	-	-
C-F-1	V2 21204-122-4		ISI-21204-122	ISI	-	-	-	-	-	-	-
C5.11	21204-122-4		10" PIPE TO ELBOW	AUG	-	-	-	-	-	-	-
2	1204			OWN	-	-	-	-	-	-	-
				PRE	-	-	-	-	-	-	-
C-F-1	V2 21204-122-5		ISI-21204-122	ISI	-	-	-	-	-	-	-
C5.11	21204-122-5		10" ELBOW TO PIPE	AUG	-	-	-	-	-	-	-
2	1204			OWN	-	-	-	-	-	-	-

Southern Nuclear Operating Company
3rd Interval
VOGTLE-2 ISI PLAN, VERSION 3.0

Category, Item No., Class	Summary No./ComplD/System	Scope / Method / Procedure	Dwg/ISO No. Comp. Desc. Code Case		Period 1		Period 2			Period 3	
					2VR13	2VR14	2VR14A	2VR15	2VR16	2VR17	2VR18
C-F-1	V2 21204-122-6	ISI/UT/	ISI-21204-122	PRE	-	-	-	-	-	-	-
C5.11	21204-122-6		10" PIPE TO VALVE (AI 87-0131)	ISI	-	-	-	-	-	-	-
2	1204			AUG	-	-	-	-	-	-	-
				OWN	-	-	-	-	-	-	-
				PRE	-	-	-	-	-	-	-
C-F-1	V2 21204-123-1		ISI-21204-123	ISI	-	-	-	-	-	-	-
C5.11	21204-123-1		10" SAFE END TO PIPE (AI 87-0131)	AUG	-	-	-	-	-	-	-
2	1204			OWN	-	-	-	-	-	-	-
				PRE	-	-	-	-	-	-	-
C-F-1	V2 21204-123-2		ISI-21204-123	ISI	-	-	-	-	-	-	-
C5.11	21204-123-2		10" PIPE TO ELBOW	AUG	-	-	-	-	-	-	-
2	1204			OWN	-	-	-	-	-	-	-
				PRE	-	-	-	-	-	-	-
C-F-1	V2 21204-123-3		ISI-21204-123	ISI	-	-	-	-	-	-	-
C5.11	21204-123-3		10" ELBOW TO PIPE	AUG	-	-	-	-	-	-	-
2	1204			OWN	-	-	-	-	-	-	-
				PRE	-	-	-	-	-	-	-
C-F-1	V2 21204-123-4		ISI-21204-123	ISI	-	-	-	-	-	-	-
C5.11	21204-123-4		10" PIPE TO ELBOW	AUG	-	-	-	-	-	-	-
2	1204			OWN	-	-	-	-	-	-	-
				PRE	-	-	-	-	-	-	-
C-F-1	V2 21204-123-5		ISI-21204-123	ISI	-	-	-	-	-	-	-
C5.11	21204-123-5		10" ELBOW TO PIPE	AUG	-	-	-	-	-	-	-
2	1204			OWN	-	-	-	-	-	-	-
				PRE	-	-	-	-	-	-	-
C-F-1	V2 21204-123-6		ISI-21204-123	ISI	-	-	-	-	-	-	-
C5.11	21204-123-6		10" PIPE TO VALVE	AUG	-	-	-	-	-	-	-
2	1204			OWN	-	-	-	-	-	-	-
				PRE	-	-	-	-	-	-	-
C-F-1	V2 21204-177-1		ISI-21204-177	ISI	-	-	-	-	-	-	-
C5.11	21204-177-1		8" BRANCH CONNECTION TO PIPE	AUG	-	-	-	-	-	-	-
2	1204			OWN	-	-	-	-	-	-	-
				PRE	-	-	-	-	-	-	-
C-F-1	V2 21204-177-10		ISI-21204-177	ISI	-	-	-	-	-	-	-
C5.11	21204-177-10		8" PIPE TO TEE	AUG	-	-	-	-	-	-	-
2	1204			OWN	-	-	-	-	-	-	-
				PRE	-	-	-	-	-	-	-
C-F-1	V2 21204-177-11		ISI-21204-177	ISI	-	-	-	-	-	-	-
C5.11	21204-177-11		8" TEE TO PIPE	AUG	-	-	-	-	-	-	-
2	1204			OWN	-	-	-	-	-	-	-

Southern Nuclear Operating Company
3rd Interval
VOGTLE-2 ISI PLAN, VERSION 3.0

Category, Item No., Class	Summary No./ComplID/System	Scope / Method / Procedure	Dwg/ISO No. Comp. Desc. Code Case		Period 1		Period 2			Period 3	
					2VR13	2VR14	2VR14A	2VR15	2VR16	2VR17	2VR18
C-F-1	V2 21204-177-13		ISI-21204-177	PRE	-	-	-	-	-	-	-
C5.11	21204-177-13		8" PIPE TO VALVE	ISI	-	-	-	-	-	-	-
2	1204			AUG	-	-	-	-	-	-	-
				OWN	-	-	-	-	-	-	-
				PRE	-	-	-	-	-	-	-
C-F-1	V2 21204-177-14		ISI-21204-177	ISI	-	-	-	-	-	-	-
C5.11	21204-177-14		8" TEE TO PIPE	AUG	-	-	-	-	-	-	-
2	1204			OWN	-	-	-	-	-	-	-
				PRE	-	-	-	-	-	-	-
C-F-1	V2 21204-177-16		ISI-21204-177	ISI	-	-	-	-	-	-	-
C5.11	21204-177-16		8" PIPE TO VALVE	AUG	-	-	-	-	-	-	-
2	1204			OWN	-	-	-	-	-	-	-
				PRE	-	-	-	-	-	-	-
C-F-1	V2 21204-177-2		ISI-21204-177	ISI	-	-	-	-	-	-	-
C5.11	21204-177-2		8" PIPE TO PIPE	AUG	-	-	-	-	-	-	-
2	1204			OWN	-	-	-	-	-	-	-
				PRE	-	-	-	-	-	-	-
C-F-1	V2 21204-177-3		ISI-21204-177	ISI	-	-	-	-	-	-	-
C5.11	21204-177-3		8" PIPE TO ELBOW	AUG	-	-	-	-	-	-	-
2	1204			OWN	-	-	-	-	-	-	-
				PRE	-	-	-	-	-	-	-
C-F-1	V2 21204-177-4		ISI-21204-177	ISI	-	-	-	-	-	-	-
C5.11	21204-177-4		8" ELBOW TO PIPE	AUG	-	-	-	-	-	-	-
2	1204			OWN	-	-	-	-	-	-	-
				PRE	-	-	-	-	-	-	-
C-F-1	V2 21204-177-5		ISI-21204-177	ISI	-	-	-	-	-	-	-
C5.11	21204-177-5		8" PIPE TO ELBOW	AUG	-	-	-	-	-	-	-
2	1204			OWN	-	-	-	-	-	-	-
				PRE	-	-	-	-	-	-	-
C-F-1	V2 21204-177-6		ISI-21204-177	ISI	-	-	-	-	-	-	-
C5.11	21204-177-6		8" ELBOW TO PIPE	AUG	-	-	-	-	-	-	-
2	1204			OWN	-	-	-	-	-	-	-
				PRE	-	-	-	-	-	-	-
C-F-1	V2 21204-177-7		ISI-21204-177	ISI	-	-	-	-	-	-	-
C5.11	21204-177-7		8" PIPE TO ELBOW	AUG	-	-	-	-	-	-	-
2	1204			OWN	-	-	-	-	-	-	-
				PRE	-	-	-	-	-	-	-
C-F-1	V2 21204-177-8		ISI-21204-177	ISI	-	-	-	-	-	-	-
C5.11	21204-177-8		8" ELBOW TO PIPE	AUG	-	-	-	-	-	-	-
2	1204			OWN	-	-	-	-	-	-	-

Southern Nuclear Operating Company
3rd Interval
VOGTLE-2 ISI PLAN, VERSION 3.0

Category, Item No., Class	Summary No./ComplD/System	Scope / Method / Procedure	Dwg/ISO No. Comp. Desc. Code Case		Period 1		Period 2			Period 3	
					2VR13	2VR14	2VR14A	2VR15	2VR16	2VR17	2VR18
C-F-1	V2 21204-177-9		ISI-21204-177	PRE	-	-	-	-	-	-	-
C5.11	21204-177-9		8" PIPE TO PIPE	ISI	-	-	-	-	-	-	-
2	1204			AUG	-	-	-	-	-	-	-
				OWN	-	-	-	-	-	-	-
				PRE	-	-	-	-	-	-	-
C-F-1	V2 21204-192-1		ISI-21204-192	ISI	-	-	-	-	-	-	-
C5.11	21204-192-1		8" VALVE TO PIPE	AUG	-	-	-	-	-	-	-
2	1204			OWN	-	-	-	-	-	-	-
				PRE	-	-	-	-	-	-	-
C-F-1	V2 21204-192-2		ISI-21204-192	ISI	-	-	-	-	-	-	-
C5.11	21204-192-2		8" PIPE TO ELBOW	AUG	-	-	-	-	-	-	-
2	1204			OWN	-	-	-	-	-	-	-
				PRE	-	-	-	-	-	-	-
C-F-1	V2 21204-192-3		ISI-21204-192	ISI	-	-	-	-	-	-	-
C5.11	21204-192-3		8" ELBOW TO PIPE	AUG	-	-	-	-	-	-	-
2	1204			OWN	-	-	-	-	-	-	-
				PRE	-	-	-	-	-	-	-
C-F-1	V2 21204-192-3 A		ISI-21204-192	ISI	-	-	-	-	-	-	-
C5.11	21204-192-3 A		8" PIPE TO FLANGE	AUG	-	-	-	-	-	-	-
2	1204			OWN	-	-	-	-	-	-	-
				PRE	-	-	-	-	-	-	-
C-F-1	V2 21204-192-3 B		ISI-21204-192	ISI	-	-	-	-	-	-	-
C5.11	21204-192-3 B		8" FLANGE TO PIPE	AUG	-	-	-	-	-	-	-
2	1204			OWN	-	-	-	-	-	-	-
				PRE	-	-	-	-	-	-	-
C-F-1	V2 21204-192-3 C		ISI-21204-192	ISI	-	-	-	-	-	-	-
C5.11	21204-192-3 C		8" PIPE TO FLANGE	AUG	-	-	-	-	-	-	-
2	1204			OWN	-	-	-	-	-	-	-
				PRE	-	-	-	-	-	-	-
C-F-1	V2 21204-192-3 D		ISI-21204-192	ISI	-	-	-	-	-	-	-
C5.11	21204-192-3 D		8" FLANGE TO PIPE	AUG	-	-	-	-	-	-	-
2	1204			OWN	-	-	-	-	-	-	-
				PRE	-	-	-	-	-	-	-
C-F-1	V2 21204-192-4		ISI-21204-192	ISI	-	-	-	-	-	-	-
C5.11	21204-192-4		8" PIPE TO BRANCH CONNECTION	AUG	-	-	-	-	-	-	-
2	1204			OWN	-	-	-	-	-	-	-
				PRE	-	-	-	-	-	-	-
C-F-1	V2 21204-201-1		ISI-21204-201	ISI	-	-	-	-	-	-	-
C5.11	21204-201-1		12" VALVE TO PIPE	AUG	-	-	-	-	-	-	-
2	1204			OWN	-	-	-	-	-	-	-

Southern Nuclear Operating Company
3rd Interval
VOGTLE-2 ISI PLAN, VERSION 3.0

Category, Item No., Class	Summary No./CompID/System	Scope / Method / Procedure	Dwg/ISO No. Comp. Desc. Code Case		Period 1		Period 2			Period 3	
					2VR13	2VR14	2VR14A	2VR15	2VR16	2VR17	2VR18
C-F-1	V2 21204-201-10		ISI-21204-201	PRE	-	-	-	-	-	-	-
C5.11	21204-201-10		8" PIPE TO ELBOW	ISI	-	-	-	-	-	-	-
2	1204			AUG	-	-	-	-	-	-	-
				OWN	-	-	-	-	-	-	-
				PRE	-	-	-	-	-	-	-
C-F-1	V2 21204-201-11		ISI-21204-201	ISI	-	-	-	-	-	-	-
C5.11	21204-201-11		8" ELBOW TO PIPE	AUG	-	-	-	-	-	-	-
2	1204			OWN	-	-	-	-	-	-	-
				PRE	-	-	-	-	-	-	-
C-F-1	V2 21204-201-12		ISI-21204-201	ISI	-	-	-	-	-	-	-
C5.11	21204-201-12		8" PIPE TO ELBOW	AUG	-	-	-	-	-	-	-
2	1204			OWN	-	-	-	-	-	-	-
				PRE	-	-	-	-	-	-	-
C-F-1	V2 21204-201-13		ISI-21204-201	ISI	-	-	-	-	-	-	-
C5.11	21204-201-13		8" ELBOW TO PIPE	AUG	-	-	-	-	-	-	-
2	1204			OWN	-	-	-	-	-	-	-
				PRE	-	-	-	-	-	-	-
C-F-1	V2 21204-201-14		ISI-21204-201	ISI	-	-	-	-	-	-	-
C5.11	21204-201-14		8" PIPE TO ELBOW	AUG	-	-	-	-	-	-	-
2	1204			OWN	-	-	-	-	-	-	-
				PRE	-	-	-	-	-	-	-
C-F-1	V2 21204-201-15		ISI-21204-201	ISI	-	-	-	-	-	-	-
C5.11	21204-201-15		8" ELBOW TO PIPE	AUG	-	-	-	-	-	-	-
2	1204			OWN	-	-	-	-	-	-	-
				PRE	-	-	-	-	-	-	-
C-F-1	V2 21204-201-17		ISI-21204-201	ISI	-	-	-	-	-	-	-
C5.11	21204-201-17		8" PIPE TO ELBOW	AUG	-	-	-	-	-	-	-
2	1204			OWN	-	-	-	-	-	-	-
				PRE	-	-	-	-	-	-	-
C-F-1	V2 21204-201-18		ISI-21204-201	ISI	-	-	-	-	-	-	-
C5.11	21204-201-18		8" ELBOW TO PIPE	AUG	-	-	-	-	-	-	-
2	1204			OWN	-	-	-	-	-	-	-
				PRE	-	-	-	-	-	-	-
C-F-1	V2 21204-201-19		ISI-21204-201	ISI	-	-	-	-	-	-	-
C5.11	21204-201-19		8" PIPE TO VALVE	AUG	-	-	-	-	-	-	-
2	1204			OWN	-	-	-	-	-	-	-
				PRE	-	-	-	-	-	-	-
C-F-1	V2 21204-201-2		ISI-21204-201	ISI	-	-	-	-	-	-	-
C5.11	21204-201-2		12" PIPE TO PIPE	AUG	-	-	-	-	-	-	-
2	1204			OWN	-	-	-	-	-	-	-

Southern Nuclear Operating Company
3rd Interval
VOGTLE-2 ISI PLAN, VERSION 3.0

Category, Item No., Class	Summary No./ComplID/System	Scope / Method / Procedure	Dwg/ISO No. Comp. Desc. Code Case		Period 1		Period 2			Period 3	
					2VR13	2VR14	2VR14A	2VR15	2VR16	2VR17	2VR18
C-F-1	V2 21204-201-3		ISI-21204-201	PRE	-	-	-	-	-	-	-
C5.11	21204-201-3		12" PIPE TO PENETRATION	ISI	-	-	-	-	-	-	-
2	1204			AUG	-	-	-	-	-	-	-
				OWN	-	-	-	-	-	-	-
				PRE	-	-	-	-	-	-	-
C-F-1	V2 21204-201-4		ISI-21204-201	ISI	-	-	-	-	-	-	-
C5.11	21204-201-4		12" PENETRATION TO PIPE	AUG	-	-	-	-	-	-	-
2	1204			OWN	-	-	-	-	-	-	-
				PRE	-	-	-	-	-	-	-
C-F-1	V2 21204-201-5		ISI-21204-201	ISI	-	-	-	-	-	-	-
C5.11	21204-201-5		12" PIPE TO PIPE	AUG	-	-	-	-	-	-	-
2	1204			OWN	-	-	-	-	-	-	-
				PRE	-	-	-	-	-	-	-
C-F-1	V2 21204-201-6		ISI-21204-201	ISI	-	-	-	-	-	-	-
C5.11	21204-201-6		12" PIPE TO TEE	AUG	-	-	-	-	-	-	-
2	1204			OWN	-	-	-	-	-	-	-
				PRE	-	-	-	-	-	-	-
C-F-1	V2 21204-201-7		ISI-21204-201	ISI	-	-	-	-	-	-	-
C5.11	21204-201-7		12" TEE TO PIPE (AI 87-0131)	AUG	-	-	-	-	-	-	-
2	1204			OWN	-	-	-	-	-	-	-
				PRE	-	-	-	-	-	-	-
C-F-1	V2 21204-201-8		ISI-21204-201	ISI	-	-	-	-	-	-	-
C5.11	21204-201-8		12" PIPE TO REDUCER (AI 87-0131)	AUG	-	-	-	-	-	-	-
2	1204			OWN	-	-	-	-	-	-	-
				PRE	-	-	-	-	-	-	-
C-F-1	V2 21204-201-9		ISI-21204-201	ISI	-	-	-	-	-	-	-
C5.11	21204-201-9		8" REDUCER TO PIPE	AUG	-	-	-	-	-	-	-
2	1204			OWN	-	-	-	-	-	-	-
				PRE	-	-	-	-	-	-	-
C-F-1	V2 21205-001-1		ISI-21205-001	ISI	-	-	-	-	-	-	-
C5.11	21205-001-1		12" VALVE TO PIPE	AUG	-	-	-	-	-	-	-
2	1205			OWN	-	-	-	-	-	-	-
				PRE	-	-	-	-	-	-	-
C-F-1	V2 21205-001-2	ISI/UT/NMP-ES-024-501	ISI-21205-001	ISI	-	s	-	-	-	-	-
C5.11	21205-001-2		12" PIPE TO EXTENSION SLEEVE	AUG	-	-	-	-	-	-	-
2	1205			OWN	-	-	-	-	-	-	-
				PRE	-	-	-	-	-	-	-
C-F-1	V2 21205-001-3	ISI/UT/NMP-ES-024-501	ISI-21205-001	ISI	-	s	-	-	-	-	-
C5.11	21205-001-3		12" EXTENSION SLEEVE TO PENETRATION	AUG	-	-	-	-	-	-	-

Southern Nuclear Operating Company
3rd Interval
VOGTLE-2 ISI PLAN, VERSION 3.0

Category, Item No., Class	Summary No./ComplID/System	Scope / Method / Procedure	Dwg/ISO No. Comp. Desc. Code Case		Period 1		Period 2			Period 3	
					2VR13	2VR14	2VR14A	2VR15	2VR16	2VR17	2VR18
2	1205			OWN	-	-	-	-	-	-	-
				PRE	-	-	-	-	-	-	-
C-F-1	V2 21205-002-1		ISI-21205-002	ISI	-	-	-	-	-	-	-
C5.11	21205-002-1		12" VALVE TO PIPE	AUG	-	-	-	-	-	-	-
2	1205			OWN	-	-	-	-	-	-	-
				PRE	-	-	-	-	-	-	-
C-F-1	V2 21205-002-2		ISI-21205-002	ISI	-	-	-	-	-	-	-
C5.11	21205-002-2		12" PIPE TO EXTENSION SLEEVE	AUG	-	-	-	-	-	-	-
2	1205			OWN	-	-	-	-	-	-	-
				PRE	-	-	-	-	-	-	-
C-F-1	V2 21205-002-3		ISI-21205-002	ISI	-	-	-	-	-	-	-
C5.11	21205-002-3		12" EXTENSION SLEEVE TO PENETRATION	AUG	-	-	-	-	-	-	-
2	1205			OWN	-	-	-	-	-	-	-
				PRE	-	-	-	-	-	-	-
C-F-1	V2 21205-003-1		ISI-21205-003	ISI	-	-	-	-	-	-	-
C5.11	21205-003-1		12" PENETRATION TO EXTENSION SLEEVE	AUG	-	-	-	-	-	-	-
2	1205			OWN	-	-	-	-	-	-	-
				PRE	-	-	-	-	-	-	-
C-F-1	V2 21205-003-10		ISI-21205-003	ISI	-	-	-	-	-	-	-
C5.11	21205-003-10		12" PIPE TO ELBOW	AUG	-	-	-	-	-	-	-
2	1205			OWN	-	-	-	-	-	-	-
				PRE	-	-	-	-	-	-	-
C-F-1	V2 21205-003-11		ISI-21205-003	ISI	-	-	-	-	-	-	-
C5.11	21205-003-11		12" ELBOW TO PIPE	AUG	-	-	-	-	-	-	-
2	1205			OWN	-	-	-	-	-	-	-
				PRE	-	-	-	-	-	-	-
C-F-1	V2 21205-003-12		ISI-21205-003	ISI	-	-	-	-	-	-	-
C5.11	21205-003-12		12" PIPE TO PIPE	AUG	-	-	-	-	-	-	-
2	1205			OWN	-	-	-	-	-	-	-
				PRE	-	-	-	-	-	-	-
C-F-1	V2 21205-003-13		ISI-21205-003	ISI	-	-	-	-	-	-	-
C5.11	21205-003-13		12" PIPE TO PIPE	AUG	-	-	-	-	-	-	-
2	1205			OWN	-	-	-	-	-	-	-
				PRE	-	-	-	-	-	-	-
C-F-1	V2 21205-003-14		ISI-21205-003	ISI	-	-	-	-	-	-	-
C5.11	21205-003-14		12" PIPE TO ELBOW	AUG	-	-	-	-	-	-	-
2	1205			OWN	-	-	-	-	-	-	-
				PRE	-	-	-	-	-	-	-

Southern Nuclear Operating Company
3rd Interval
VOGTLE-2 ISI PLAN, VERSION 3.0

Category, Item No., Class	Summary No./CompID/System	Scope / Method / Procedure	Dwg/ISO No. Comp. Desc. Code Case		Period 1		Period 2			Period 3	
					2VR13	2VR14	2VR14A	2VR15	2VR16	2VR17	2VR18
C-F-1 C5.11 2	V2 21205-003-15 21205-003-15 1205		ISI-21205-003 12" ELBOW TO PIPE	ISI AUG OWN PRE	-	-	-	-	-	-	-
C-F-1 C5.11 2	V2 21205-003-16 21205-003-16 1205		ISI-21205-003 12" PIPE TO ELBOW	ISI AUG OWN PRE	-	-	-	-	-	-	-
C-F-1 C5.11 2	V2 21205-003-17 21205-003-17 1205		ISI-21205-003 12" ELBOW TO PIPE	ISI AUG OWN PRE	-	-	-	-	-	-	-
C-F-1 C5.11 2	V2 21205-003-19 21205-003-19 1205		ISI-21205-003 12" PIPE TO ELBOW	ISI AUG OWN PRE	-	-	-	-	-	-	-
C-F-1 C5.11 2	V2 21205-003-2 21205-003-2 1205		ISI-21205-003 12" EXTENSION SLEEVE TO PIPE (AI 87-0131)	ISI AUG OWN PRE	-	-	-	-	-	-	-
C-F-1 C5.11 2	V2 21205-003-20 21205-003-20 1205		ISI-21205-003 12" ELBOW TO PIPE	ISI AUG OWN PRE	-	-	-	-	-	-	-
C-F-1 C5.11 2	V2 21205-003-21 21205-003-21 1205	ISI/UT/	ISI-21205-003 12" PIPE TO ELBOW	ISI AUG OWN PRE	-	-	-	-	-	s	-
C-F-1 C5.11 2	V2 21205-003-22 21205-003-22 1205	ISI/UT/	ISI-21205-003 12" ELBOW TO PIPE	ISI AUG OWN PRE	-	-	-	-	-	s	-
C-F-1 C5.11 2	V2 21205-003-23 21205-003-23 1205		ISI-21205-003 12" PIPE TO ELBOW	ISI AUG OWN PRE	-	-	-	-	-	-	-
C-F-1 C5.11 2	V2 21205-003-24 21205-003-24 1205		ISI-21205-003 12" ELBOW TO PIPE	ISI AUG OWN	-	-	-	-	-	-	-

Southern Nuclear Operating Company
3rd Interval
VOGTLE-2 ISI PLAN, VERSION 3.0

Category, Item No., Class	Summary No./ComplD/System	Scope / Method / Procedure	Dwg/ISO No. Comp. Desc. Code Case		Period 1		Period 2			Period 3	
					2VR13	2VR14	2VR14A	2VR15	2VR16	2VR17	2VR18
C-F-1	V2 21205-003-25		ISI-21205-003	PRE	-	-	-	-	-	-	-
C5.11	21205-003-25		12" PIPE TO TEE	ISI	-	-	-	-	-	-	-
2	1205			AUG	-	-	-	-	-	-	-
				OWN	-	-	-	-	-	-	-
				PRE	-	-	-	-	-	-	-
C-F-1	V2 21205-003-26		ISI-21205-003	ISI	-	-	-	-	-	-	-
C5.11	21205-003-26		14" VALVE TO PIPE	AUG	-	-	-	-	-	-	-
2	1205			OWN	-	-	-	-	-	-	-
				PRE	-	-	-	-	-	-	-
C-F-1	V2 21205-003-27		ISI-21205-003	ISI	-	-	-	-	-	-	-
C5.11	21205-003-27		14" PIPE TO TEE	AUG	-	-	-	-	-	-	-
2	1205			OWN	-	-	-	-	-	-	-
				PRE	-	-	-	-	-	-	-
C-F-1	V2 21205-003-28		ISI-21205-003	ISI	-	-	-	-	-	-	-
C5.11	21205-003-28		14" TEE TO PIPE (AI 87-0131)	AUG	-	-	-	-	-	-	-
2	1205			OWN	-	-	-	-	-	-	-
				PRE	-	-	-	-	-	-	-
C-F-1	V2 21205-003-29		ISI-21205-003	ISI	-	-	-	-	-	-	-
C5.11	21205-003-29		14" PIPE TO ELBOW	AUG	-	-	-	-	-	-	-
2	1205			OWN	-	-	-	-	-	-	-
				PRE	-	-	-	-	-	-	-
C-F-1	V2 21205-003-3		ISI-21205-003	ISI	-	-	-	-	-	-	-
C5.11	21205-003-3		12" PIPE TO ELBOW (AI 87-0131)	AUG	-	-	-	-	-	-	-
2	1205			OWN	-	-	-	-	-	-	-
				PRE	-	-	-	-	-	-	-
C-F-1	V2 21205-003-30		ISI-21205-003	ISI	-	-	-	-	-	-	-
C5.11	21205-003-30		14" ELBOW TO PIPE	AUG	-	-	-	-	-	-	-
2	1205			OWN	-	-	-	-	-	-	-
				PRE	-	-	-	-	-	-	-
C-F-1	V2 21205-003-31		ISI-21205-003	ISI	-	-	-	-	-	-	-
C5.11	21205-003-31		14" PIPE TO ELBOW	AUG	-	-	-	-	-	-	-
2	1205			OWN	-	-	-	-	-	-	-
				PRE	-	-	-	-	-	-	-
C-F-1	V2 21205-003-32		ISI-21205-003	ISI	-	-	-	-	-	-	-
C5.11	21205-003-32		14" ELBOW TO PIPE	AUG	-	-	-	-	-	-	-
2	1205			OWN	-	-	-	-	-	-	-
				PRE	-	-	-	-	-	-	-
C-F-1	V2 21205-003-33		ISI-21205-003	ISI	-	-	-	-	-	-	-
C5.11	21205-003-33		14" PIPE TO ELBOW	AUG	-	-	-	-	-	-	-
2	1205			OWN	-	-	-	-	-	-	-

Southern Nuclear Operating Company
3rd Interval
VOGTLE-2 ISI PLAN, VERSION 3.0

Category, Item No., Class	Summary No./CompID/System	Scope / Method / Procedure	Dwg/ISO No. Comp. Desc. Code Case		Period 1		Period 2			Period 3	
					2VR13	2VR14	2VR14A	2VR15	2VR16	2VR17	2VR18
C-F-1	V2 21205-003-34		ISI-21205-003	PRE	-	-	-	-	-	-	-
C5.11	21205-003-34		14" ELBOW TO PIPE	ISI	-	-	-	-	-	-	-
2	1205			AUG	-	-	-	-	-	-	-
				OWN	-	-	-	-	-	-	-
				PRE	-	-	-	-	-	-	-
C-F-1	V2 21205-003-36		ISI-21205-003	ISI	-	-	-	-	-	-	-
C5.11	21205-003-36		14" PIPE TO ELBOW	AUG	-	-	-	-	-	-	-
2	1205			OWN	-	-	-	-	-	-	-
				PRE	-	-	-	-	-	-	-
C-F-1	V2 21205-003-37		ISI-21205-003	ISI	-	-	-	-	-	-	-
C5.11	21205-003-37		14" ELBOW TO PIPE	AUG	-	-	-	-	-	-	-
2	1205			OWN	-	-	-	-	-	-	-
				PRE	-	-	-	-	-	-	-
C-F-1	V2 21205-003-4		ISI-21205-003	ISI	-	-	-	-	-	-	-
C5.11	21205-003-4		12" ELBOW TO PIPE	AUG	-	-	-	-	-	-	-
2	1205			OWN	-	-	-	-	-	-	-
				PRE	-	-	-	-	-	-	-
C-F-1	V2 21205-003-40		ISI-21205-003	ISI	-	-	-	-	-	-	-
C5.11	21205-003-40		14" PIPE TO PIPE	AUG	-	-	-	-	-	-	-
2	1205			OWN	-	-	-	-	-	-	-
				PRE	-	-	-	-	-	-	-
C-F-1	V2 21205-003-41		ISI-21205-003	ISI	-	-	-	-	-	-	-
C5.11	21205-003-41		14" PIPE TO ELBOW	AUG	-	-	-	-	-	-	-
2	1205			OWN	-	-	-	-	-	-	-
				PRE	-	-	-	-	-	-	-
C-F-1	V2 21205-003-42		ISI-21205-003	ISI	-	-	-	-	-	-	-
C5.11	21205-003-42		14" ELBOW TO PIPE	AUG	-	-	-	-	-	-	-
2	1205			OWN	-	-	-	-	-	-	-
				PRE	-	-	-	-	-	-	-
C-F-1	V2 21205-003-43		ISI-21205-003	ISI	-	-	-	-	-	-	-
C5.11	21205-003-43		14" PIPE TO PIPE	AUG	-	-	-	-	-	-	-
2	1205			OWN	-	-	-	-	-	-	-
				PRE	-	-	-	-	-	-	-
C-F-1	V2 21205-003-45		ISI-21205-003	ISI	-	-	-	-	-	-	-
C5.11	21205-003-45		14" PIPE TO PIPE	AUG	-	-	-	-	-	-	-
2	1205			OWN	-	-	-	-	-	-	-
				PRE	-	-	-	-	-	-	-
C-F-1	V2 21205-003-46	ISI/UT/NMP-ES-024-501	ISI-21205-003	ISI	c	-	-	-	-	-	-
C5.11	21205-003-46	ISI/UT/NMP-ES-024-501	14" PIPE TO ELBOW	AUG	-	-	-	-	-	-	-
2	1205			OWN	-	-	-	-	-	-	-

Southern Nuclear Operating Company
3rd Interval
VOGTLE-2 ISI PLAN, VERSION 3.0

Category, Item No., Class	Summary No./ComplD/System	Scope / Method / Procedure	Dwg/ISO No. Comp. Desc. Code Case		Period 1		Period 2			Period 3	
					2VR13	2VR14	2VR14A	2VR15	2VR16	2VR17	2VR18
C-F-1	V2 21205-003-47	ISI/UT/NMP-ES-024-501	ISI-21205-003	PRE	-	-	-	-	-	-	-
C5.11	21205-003-47	ISI/UT/NMP-ES-024-501	14" ELBOW TO PIPE	ISI	c	-	-	-	-	-	-
2	1205			AUG	-	-	-	-	-	-	-
				OWN	-	-	-	-	-	-	-
				PRE	-	-	-	-	-	-	-
C-F-1	V2 21205-003-48	ISI/UT/NMP-ES-024-501	ISI-21205-003	ISI	c	-	-	-	-	-	-
C5.11	21205-003-48	ISI/UT/NMP-ES-024-501	14" PIPE TO ELBOW	AUG	-	-	-	-	-	-	-
2	1205			OWN	-	-	-	-	-	-	-
				PRE	-	-	-	-	-	-	-
C-F-1	V2 21205-003-49	ISI/UT/NMP-ES-024-501	ISI-21205-003	ISI	c	-	-	-	-	-	-
C5.11	21205-003-49	ISI/UT/NMP-ES-024-501	14" ELBOW TO PIPE	AUG	-	-	-	-	-	-	-
2	1205			OWN	-	-	-	-	-	-	-
				PRE	-	-	-	-	-	-	-
C-F-1	V2 21205-003-5		ISI-21205-003	ISI	-	-	-	-	-	-	-
C5.11	21205-003-5		12" PIPE TO ELBOW	AUG	-	-	-	-	-	-	-
2	1205			OWN	-	-	-	-	-	-	-
				PRE	-	-	-	-	-	-	-
C-F-1	V2 21205-003-50		ISI-21205-003	ISI	-	-	-	-	-	-	-
C5.11	21205-003-50		14" PIPE TO TEE	AUG	-	-	-	-	-	-	-
2	1205			OWN	-	-	-	-	-	-	-
				PRE	-	-	-	-	-	-	-
C-F-1	V2 21205-003-51		ISI-21205-003	ISI	-	-	-	-	-	-	-
C5.11	21205-003-51		14" TEE TO PIPE	AUG	-	-	-	-	-	-	-
2	1205			OWN	-	-	-	-	-	-	-
				PRE	-	-	-	-	-	-	-
C-F-1	V2 21205-003-52		ISI-21205-003	ISI	-	-	-	-	-	-	-
C5.11	21205-003-52		14" PIPE TO ELBOW	AUG	-	-	-	-	-	-	-
2	1205			OWN	-	-	-	-	-	-	-
				PRE	-	-	-	-	-	-	-
C-F-1	V2 21205-003-53		ISI-21205-003	ISI	-	-	-	-	-	-	-
C5.11	21205-003-53		14" ELBOW TO FLANGE	AUG	-	-	-	-	-	-	-
2	1205			OWN	-	-	-	-	-	-	-
				PRE	-	-	-	-	-	-	-
C-F-1	V2 21205-003-55		ISI-21205-003	ISI	-	-	-	-	-	-	-
C5.11	21205-003-55		14" FLANGE TO PIPE	AUG	-	-	-	-	-	-	-
2	1205			OWN	-	-	-	-	-	-	-
				PRE	-	-	-	-	-	-	-
C-F-1	V2 21205-003-56		ISI-21205-003	ISI	-	-	-	-	-	-	-
C5.11	21205-003-56		14" PIPE TO FLANGE	AUG	-	-	-	-	-	-	-
2	1205			OWN	-	-	-	-	-	-	-

Southern Nuclear Operating Company
3rd Interval
VOGTLE-2 ISI PLAN, VERSION 3.0

Category, Item No., Class	Summary No./ComplID/System	Scope / Method / Procedure	Dwg/ISO No. Comp. Desc. Code Case	PRE	Period 1		Period 2			Period 3	
					2VR13	2VR14	2VR14A	2VR15	2VR16	2VR17	2VR18
C-F-1 C5.11 2	V2 21205-003-57 21205-003-57 1205		ISI-21205-003 14" FLANGE TO PIPE	ISI AUG OWN PRE	-	-	-	-	-	-	-
C-F-1 C5.11 2	V2 21205-003-58 21205-003-58 1205		ISI-21205-003 14" PIPE TO ELBOW	ISI AUG OWN PRE	-	-	-	-	-	-	-
C-F-1 C5.11 2	V2 21205-003-59 21205-003-59 1205		ISI-21205-003 14" ELBOW TO PIPE (AI 87-0131)	ISI AUG OWN PRE	-	-	-	-	-	-	-
C-F-1 C5.11 2	V2 21205-003-6 21205-003-6 1205		ISI-21205-003 12" ELBOW TO PIPE	ISI AUG OWN PRE	-	-	-	-	-	-	-
C-F-1 C5.11 2	V2 21205-003-60 21205-003-60 1205		ISI-21205-003 14" PIPE TO PUMP SUCTION	ISI AUG OWN PRE	-	-	-	-	-	-	-
C-F-1 C5.11 2	V2 21205-003-7 21205-003-7 1205		ISI-21205-003 12" PIPE TO PIPE	ISI AUG OWN PRE	-	-	-	-	-	-	-
C-F-1 C5.11 2	V2 21205-003-9 21205-003-9 1205		ISI-21205-003 12" PIPE TO PIPE	ISI AUG OWN PRE	-	-	-	-	-	-	-
C-F-1 C5.11 2	V2 21205-004-1 21205-004-1 1205	ISI/UT/	ISI-21205-004 12" PENETRATION TO EXTENSION SLEEVE	ISI AUG OWN PRE	-	-	-	s	-	-	-
C-F-1 C5.11 2	V2 21205-004-10 21205-004-10 1205		ISI-21205-004 14" ELBOW TO PIPE	ISI AUG OWN PRE	-	-	-	-	-	-	-
C-F-1 C5.11	V2 21205-004-11 21205-004-11		ISI-21205-004 14" PIPE TO ELBOW	ISI AUG	-	-	-	-	-	-	-

Southern Nuclear Operating Company
3rd Interval
VOGTLE-2 ISI PLAN, VERSION 3.0

Category, Item No., Class	Summary No./CompID/System	Scope / Method / Procedure	Dwg/ISO No. Comp. Desc. Code Case		Period 1		Period 2			Period 3	
					2VR13	2VR14	2VR14A	2VR15	2VR16	2VR17	2VR18
2	1205			OWN	-	-	-	-	-	-	-
				PRE	-	-	-	-	-	-	-
C-F-1	V2 21205-004-12		ISI-21205-004	ISI	-	-	-	-	-	-	-
C5.11	21205-004-12		14" ELBOW TO PIPE	AUG	-	-	-	-	-	-	-
2	1205			OWN	-	-	-	-	-	-	-
				PRE	-	-	-	-	-	-	-
C-F-1	V2 21205-004-13		ISI-21205-004	ISI	-	-	-	-	-	-	-
C5.11	21205-004-13		14" PIPE TO ELBOW	AUG	-	-	-	-	-	-	-
2	1205			OWN	-	-	-	-	-	-	-
				PRE	-	-	-	-	-	-	-
C-F-1	V2 21205-004-14		ISI-21205-004	ISI	-	-	-	-	-	-	-
C5.11	21205-004-14		14" ELBOW TO PIPE	AUG	-	-	-	-	-	-	-
2	1205			OWN	-	-	-	-	-	-	-
				PRE	-	-	-	-	-	-	-
C-F-1	V2 21205-004-15		ISI-21205-004	ISI	-	-	-	-	-	-	-
C5.11	21205-004-15		14" PIPE TO ELBOW	AUG	-	-	-	-	-	-	-
2	1205			OWN	-	-	-	-	-	-	-
				PRE	-	-	-	-	-	-	-
C-F-1	V2 21205-004-16		ISI-21205-004	ISI	-	-	-	-	-	-	-
C5.11	21205-004-16		14" ELBOW TO PIPE	AUG	-	-	-	-	-	-	-
2	1205			OWN	-	-	-	-	-	-	-
				PRE	-	-	-	-	-	-	-
C-F-1	V2 21205-004-17		ISI-21205-004	ISI	-	-	-	-	-	-	-
C5.11	21205-004-17		14" PIPE TO TEE	AUG	-	-	-	-	-	-	-
2	1205			OWN	-	-	-	-	-	-	-
				PRE	-	-	-	-	-	-	-
C-F-1	V2 21205-004-18		ISI-21205-004	ISI	-	-	-	-	-	-	-
C5.11	21205-004-18		14" TEE TO PIPE	AUG	-	-	-	-	-	-	-
2	1205			OWN	-	-	-	-	-	-	-
				PRE	-	-	-	-	-	-	-
C-F-1	V2 21205-004-19		ISI-21205-004	ISI	-	-	-	-	-	-	-
C5.11	21205-004-19		14" PIPE TO ELBOW (AI 87-0131)	AUG	-	-	-	-	-	-	-
2	1205			OWN	-	-	-	-	-	-	-
				PRE	-	-	-	-	-	-	-
C-F-1	V2 21205-004-2		ISI-21205-004	ISI	-	-	-	-	-	-	-
C5.11	21205-004-2		12" EXTENSION SLEEVE TO REDUCER	AUG	-	-	-	-	-	-	-
2	1205			OWN	-	-	-	-	-	-	-
				PRE	-	-	-	-	-	-	-
C-F-1	V2 21205-004-20		ISI-21205-004	ISI	-	-	-	-	-	-	-
C5.11	21205-004-20		14" ELBOW TO PIPE	AUG	-	-	-	-	-	-	-

Southern Nuclear Operating Company
3rd Interval
VOGTLE-2 ISI PLAN, VERSION 3.0

Category, Item No., Class	Summary No./ComplID/System	Scope / Method / Procedure	Dwg/ISO No. Comp. Desc. Code Case		Period 1		Period 2			Period 3	
					2VR13	2VR14	2VR14A	2VR15	2VR16	2VR17	2VR18
2	1205			OWN	-	-	-	-	-	-	-
				PRE	-	-	-	-	-	-	-
C-F-1	V2 21205-004-22		ISI-21205-004	ISI	-	-	-	-	-	-	-
C5.11	21205-004-22		14" PIPE TO ELBOW	AUG	-	-	-	-	-	-	-
2	1205			OWN	-	-	-	-	-	-	-
				PRE	-	-	-	-	-	-	-
C-F-1	V2 21205-004-23		ISI-21205-004	ISI	-	-	-	-	-	-	-
C5.11	21205-004-23		14" ELBOW TO PIPE	AUG	-	-	-	-	-	-	-
2	1205			OWN	-	-	-	-	-	-	-
				PRE	-	-	-	-	-	-	-
C-F-1	V2 21205-004-24		ISI-21205-004	ISI	-	-	-	-	-	-	-
C5.11	21205-004-24		14" PIPE TO ELBOW	AUG	-	-	-	-	-	-	-
2	1205			OWN	-	-	-	-	-	-	-
				PRE	-	-	-	-	-	-	-
C-F-1	V2 21205-004-25		ISI-21205-004	ISI	-	-	-	-	-	-	-
C5.11	21205-004-25		14" ELBOW TO PIPE	AUG	-	-	-	-	-	-	-
2	1205			OWN	-	-	-	-	-	-	-
				PRE	-	-	-	-	-	-	-
C-F-1	V2 21205-004-26		ISI-21205-004	ISI	-	-	-	-	-	-	-
C5.11	21205-004-26		14" PIPE TO ELBOW	AUG	-	-	-	-	-	-	-
2	1205			OWN	-	-	-	-	-	-	-
				PRE	-	-	-	-	-	-	-
C-F-1	V2 21205-004-27		ISI-21205-004	ISI	-	-	-	-	-	-	-
C5.11	21205-004-27		14" ELBOW TO PIPE	AUG	-	-	-	-	-	-	-
2	1205			OWN	-	-	-	-	-	-	-
				PRE	-	-	-	-	-	-	-
C-F-1	V2 21205-004-28		ISI-21205-004	ISI	-	-	-	-	-	-	-
C5.11	21205-004-28		14" PIPE TO PIPE	AUG	-	-	-	-	-	-	-
2	1205			OWN	-	-	-	-	-	-	-
				PRE	-	-	-	-	-	-	-
C-F-1	V2 21205-004-3		ISI-21205-004	ISI	-	-	-	-	-	-	-
C5.11	21205-004-3		14" REDUCER TO PIPE	AUG	-	-	-	-	-	-	-
2	1205			OWN	-	-	-	-	-	-	-
				PRE	-	-	-	-	-	-	-
C-F-1	V2 21205-004-30		ISI-21205-004	ISI	-	-	-	-	-	-	-
C5.11	21205-004-30		14" PIPE TO ELBOW	AUG	-	-	-	-	-	-	-
2	1205			OWN	-	-	-	-	-	-	-
				PRE	-	-	-	-	-	-	-
C-F-1	V2 21205-004-31		ISI-21205-004	ISI	-	-	-	-	-	-	-
C5.11	21205-004-31		14" ELBOW TO PIPE	AUG	-	-	-	-	-	-	-

Southern Nuclear Operating Company
3rd Interval
VOGTLE-2 ISI PLAN, VERSION 3.0

Category, Item No., Class	Summary No./ComplID/System	Scope / Method / Procedure	Dwg/ISO No. Comp. Desc. Code Case		Period 1		Period 2			Period 3	
					2VR13	2VR14	2VR14A	2VR15	2VR16	2VR17	2VR18
2	1205			OWN	-	-	-	-	-	-	-
				PRE	-	-	-	-	-	-	-
C-F-1	V2 21205-004-32		ISI-21205-004	ISI	-	-	-	-	-	-	-
C5.11	21205-004-32		14" PIPE TO PIPE	AUG	-	-	-	-	-	-	-
2	1205			OWN	-	-	-	-	-	-	-
				PRE	-	-	-	-	-	-	-
C-F-1	V2 21205-004-33	ISI/UT/NMP-ES-024-501	ISI-21205-004	ISI	c	-	-	-	-	-	-
C5.11	21205-004-33	ISI/UT/NMP-ES-024-501	14" PIPE TO ELBOW	AUG	-	-	-	-	-	-	-
2	1205			OWN	-	-	-	-	-	-	-
				PRE	-	-	-	-	-	-	-
C-F-1	V2 21205-004-34	ISI/UT/NMP-ES-024-501	ISI-21205-004	ISI	c	-	-	-	-	-	-
C5.11	21205-004-34	ISI/UT/NMP-ES-024-501	14" ELBOW TO PIPE	AUG	-	-	-	-	-	-	-
2	1205			OWN	-	-	-	-	-	-	-
				PRE	-	-	-	-	-	-	-
C-F-1	V2 21205-004-35	ISI/UT/NMP-ES-024-501	ISI-21205-004	ISI	c	-	-	-	-	-	-
C5.11	21205-004-35	ISI/UT/NMP-ES-024-501	14" PIPE TO ELBOW	AUG	-	-	-	-	-	-	-
2	1205			OWN	-	-	-	-	-	-	-
				PRE	-	-	-	-	-	-	-
C-F-1	V2 21205-004-36	ISI/UT/NMP-ES-024-501	ISI-21205-004	ISI	c	-	-	-	-	-	-
C5.11	21205-004-36	ISI/UT/NMP-ES-024-501	14" ELBOW TO PIPE	AUG	-	-	-	-	-	-	-
2	1205			OWN	-	-	-	-	-	-	-
				PRE	-	-	-	-	-	-	-
C-F-1	V2 21205-004-37		ISI-21205-004	ISI	-	-	-	-	-	-	-
C5.11	21205-004-37		14" PIPE TO TEE	AUG	-	-	-	-	-	-	-
2	1205			OWN	-	-	-	-	-	-	-
				PRE	-	-	-	-	-	-	-
C-F-1	V2 21205-004-38		ISI-21205-004	ISI	-	-	-	-	-	-	-
C5.11	21205-004-38		14" TEE TO PIPE	AUG	-	-	-	-	-	-	-
2	1205			OWN	-	-	-	-	-	-	-
				PRE	-	-	-	-	-	-	-
C-F-1	V2 21205-004-39		ISI-21205-004	ISI	-	-	-	-	-	-	-
C5.11	21205-004-39		14" PIPE TO ELBOW	AUG	-	-	-	-	-	-	-
2	1205			OWN	-	-	-	-	-	-	-
				PRE	-	-	-	-	-	-	-
C-F-1	V2 21205-004-4		ISI-21205-004	ISI	-	-	-	-	-	-	-
C5.11	21205-004-4		14" PIPE TO ELBOW	AUG	-	-	-	-	-	-	-
2	1205			OWN	-	-	-	-	-	-	-
				PRE	-	-	-	-	-	-	-
C-F-1	V2 21205-004-40		ISI-21205-004	ISI	-	-	-	-	-	-	-
C5.11	21205-004-40		14" ELBOW TO FLANGE	AUG	-	-	-	-	-	-	-

Southern Nuclear Operating Company
3rd Interval
VOGTLE-2 ISI PLAN, VERSION 3.0

Category, Item No., Class	Summary No./CompID/System	Scope / Method / Procedure	Dwg/ISO No. Comp. Desc. Code Case		Period 1		Period 2		Period 3	
					2VR13	2VR14	2VR14A	2VR15	2VR16	2VR17
2	1205			OWN	-	-	-	-	-	-
				PRE	-	-	-	-	-	-
C-F-1	V2 21205-004-42		ISI-21205-004	ISI	-	-	-	-	-	-
C5.11	21205-004-42		14" FLANGE TO PIPE	AUG	-	-	-	-	-	-
2	1205			OWN	-	-	-	-	-	-
				PRE	-	-	-	-	-	-
C-F-1	V2 21205-004-43		ISI-21205-004	ISI	-	-	-	-	-	-
C5.11	21205-004-43		14" PIPE TO FLANGE	AUG	-	-	-	-	-	-
2	1205			OWN	-	-	-	-	-	-
				PRE	-	-	-	-	-	-
C-F-1	V2 21205-004-44		ISI-21205-004	ISI	-	-	-	-	-	-
C5.11	21205-004-44		14" FLANGE TO PIPE	AUG	-	-	-	-	-	-
2	1205			OWN	-	-	-	-	-	-
				PRE	-	-	-	-	-	-
C-F-1	V2 21205-004-45		ISI-21205-004	ISI	-	-	-	-	-	-
C5.11	21205-004-45		14" PIPE TO ELBOW	AUG	-	-	-	-	-	-
2	1205			OWN	-	-	-	-	-	-
				PRE	-	-	-	-	-	-
C-F-1	V2 21205-004-46		ISI-21205-004	ISI	-	-	-	-	-	-
C5.11	21205-004-46		14" ELBOW TO PIPE	AUG	-	-	-	-	-	-
2	1205			OWN	-	-	-	-	-	-
				PRE	-	-	-	-	-	-
C-F-1	V2 21205-004-47		ISI-21205-004	ISI	-	-	-	-	-	-
C5.11	21205-004-47		14" PIPE TO PUMP SUCTION	AUG	-	-	-	-	-	-
2	1205			OWN	-	-	-	-	-	-
				PRE	-	-	-	-	-	-
C-F-1	V2 21205-004-5		ISI-21205-004	ISI	-	-	-	-	-	-
C5.11	21205-004-5		14" ELBOW TO PIPE	AUG	-	-	-	-	-	-
2	1205			OWN	-	-	-	-	-	-
				PRE	-	-	-	-	-	-
C-F-1	V2 21205-004-7		ISI-21205-004	ISI	-	-	-	-	-	-
C5.11	21205-004-7		14" PIPE TO ELBOW	AUG	-	-	-	-	-	-
2	1205			OWN	-	-	-	-	-	-
				PRE	-	-	-	-	-	-
C-F-1	V2 21205-004-8		ISI-21205-004	ISI	-	-	-	-	-	-
C5.11	21205-004-8		14" ELBOW TO PIPE	AUG	-	-	-	-	-	-
2	1205			OWN	-	-	-	-	-	-
				PRE	-	-	-	-	-	-
C-F-1	V2 21205-004-9		ISI-21205-004	ISI	-	-	-	-	-	-
C5.11	21205-004-9		14" PIPE TO ELBOW	AUG	-	-	-	-	-	-

Southern Nuclear Operating Company
3rd Interval
VOGTLE-2 ISI PLAN, VERSION 3.0

Category, Item No., Class	Summary No./CompID/System	Scope / Method / Procedure	Dwg/ISO No. Comp. Desc. Code Case		Period 1		Period 2		Period 3	
					2VR13	2VR14	2VR14A	2VR15	2VR16	2VR17
	1205			OWN	-	-	-	-	-	-
				PRE	-	-	-	-	-	-
C-F-1	V2 21205-005-1	ISI/UT/	ISI-21205-005	ISI	-	-	-	-	-	-
C5.11	21205-005-1		8" PUMP NOZZLE TO PIPE (AI 87-0131)	AUG	-	-	-	-	-	-
2	1205			OWN	-	-	-	-	-	-
				PRE	-	-	-	-	-	-
C-F-1	V2 21205-005-10		ISI-21205-005	ISI	-	-	-	-	-	-
C5.11	21205-005-10		8" PIPE TO ELBOW	AUG	-	-	-	-	-	-
2	1205			OWN	-	-	-	-	-	-
				PRE	-	-	-	-	-	-
C-F-1	V2 21205-005-11		ISI-21205-005	ISI	-	-	-	-	-	-
C5.11	21205-005-11		8" ELBOW TO PIPE	AUG	-	-	-	-	-	-
2	1205			OWN	-	-	-	-	-	-
				PRE	-	-	-	-	-	-
C-F-1	V2 21205-005-13		ISI-21205-005	ISI	-	-	-	-	-	-
C5.11	21205-005-13		8" PIPE TO ELBOW	AUG	-	-	-	-	-	-
2	1205			OWN	-	-	-	-	-	-
				PRE	-	-	-	-	-	-
C-F-1	V2 21205-005-14		ISI-21205-005	ISI	-	-	-	-	-	-
C5.11	21205-005-14		8" ELBOW TO PIPE	AUG	-	-	-	-	-	-
2	1205			OWN	-	-	-	-	-	-
				PRE	-	-	-	-	-	-
C-F-1	V2 21205-005-15		ISI-21205-005	ISI	-	-	-	-	-	-
C5.11	21205-005-15		8" PIPE TO TEE	AUG	-	-	-	-	-	-
2	1205			OWN	-	-	-	-	-	-
				PRE	-	-	-	-	-	-
C-F-1	V2 21205-005-16		ISI-21205-005	ISI	-	-	-	-	-	-
C5.11	21205-005-16		8" TEE TO PIPE	AUG	-	-	-	-	-	-
2	1205			OWN	-	-	-	-	-	-
				PRE	-	-	-	-	-	-
C-F-1	V2 21205-005-16 A		ISI-21205-005	ISI	-	-	-	-	-	-
C5.11	21205-005-16 A		8" PIPE TO PIPE	AUG	-	-	-	-	-	-
2	1205			OWN	-	-	-	-	-	-
				PRE	-	-	-	-	-	-
C-F-1	V2 21205-005-17		ISI-21205-005	ISI	-	-	-	-	-	-
C5.11	21205-005-17		8" PIPE TO ELBOW	AUG	-	-	-	-	-	-
2	1205			OWN	-	-	-	-	-	-
				PRE	-	-	-	-	-	-
C-F-1	V2 21205-005-18	ISI/UT/	ISI-21205-005	ISI	-	-	-	-	-	-
C5.11	21205-005-18		8" ELBOW TO PIPE	AUG	-	-	-	-	-	-

Southern Nuclear Operating Company
3rd Interval
VOGTLE-2 ISI PLAN, VERSION 3.0

Category, Item No., Class	Summary No./ComplD/System	Scope / Method / Procedure	Dwg/ISO No. Comp. Desc. Code Case		Period 1		Period 2			Period 3	
					2VR13	2VR14	2VR14A	2VR15	2VR16	2VR17	2VR18
2	1205			OWN	-	-	-	-	-	-	-
				PRE	-	-	-	-	-	-	-
C-F-1	V2 21205-005-2	ISI/UT/	ISI-21205-005	ISI	-	-	-	-	-	-	-
C5.11	21205-005-2		8" PIPE TO VALVE	AUG	-	-	-	-	-	-	-
2	1205			OWN	-	-	-	-	-	-	-
				PRE	-	-	-	-	-	-	-
C-F-1	V2 21205-005-20		ISI-21205-005	ISI	-	-	-	-	-	-	-
C5.11	21205-005-20		8" PIPE TO VALVE	AUG	-	-	-	-	-	-	-
2	1205			OWN	-	-	-	-	-	-	-
				PRE	-	-	-	-	-	-	-
C-F-1	V2 21205-005-21		ISI-21205-005	ISI	-	-	-	-	-	-	-
C5.11	21205-005-21		8" VALVE TO PIPE	AUG	-	-	-	-	-	-	-
2	1205			OWN	-	-	-	-	-	-	-
				PRE	-	-	-	-	-	-	-
C-F-1	V2 21205-005-22		ISI-21205-005	ISI	-	-	-	-	-	-	-
C5.11	21205-005-22		8" PIPE TO ELBOW	AUG	-	-	-	-	-	-	-
2	1205			OWN	-	-	-	-	-	-	-
				PRE	-	-	-	-	-	-	-
C-F-1	V2 21205-005-23		ISI-21205-005	ISI	-	-	-	-	-	-	-
C5.11	21205-005-23		8" ELBOW TO PIPE (AI 87-0131)	AUG	-	-	-	-	-	-	-
2	1205			OWN	-	-	-	-	-	-	-
				PRE	-	-	-	-	-	-	-
C-F-1	V2 21205-005-24		ISI-21205-005	ISI	-	-	-	-	-	-	-
C5.11	21205-005-24		8" PIPE TO PIPE	AUG	-	-	-	-	-	-	-
2	1205			OWN	-	-	-	-	-	-	-
				PRE	-	-	-	-	-	-	-
C-F-1	V2 21205-005-25		ISI-21205-005	ISI	-	-	-	-	-	-	-
C5.11	21205-005-25		8" PIPE TO REDUCER (AI 87-0131)	AUG	-	-	-	-	-	-	-
2	1205			OWN	-	-	-	-	-	-	-
				PRE	-	-	-	-	-	-	-
C-F-1	V2 21205-005-26		ISI-21205-005	ISI	-	-	-	-	-	-	-
C5.11	21205-005-26		14" REDUCER TO PIPE	AUG	-	-	-	-	-	-	-
2	1205			OWN	-	-	-	-	-	-	-
				PRE	-	-	-	-	-	-	-
C-F-1	V2 21205-005-27		ISI-21205-005	ISI	-	-	-	-	-	-	-
C5.11	21205-005-27		14" PIPE TO ELBOW	AUG	-	-	-	-	-	-	-
2	1205			OWN	-	-	-	-	-	-	-
				PRE	-	-	-	-	-	-	-
C-F-1	V2 21205-005-28		ISI-21205-005	ISI	-	-	-	-	-	-	-
C5.11	21205-005-28		14" ELBOW TO PIPE	AUG	-	-	-	-	-	-	-

Southern Nuclear Operating Company
3rd Interval
VOGTLE-2 ISI PLAN, VERSION 3.0

Category, Item No., Class	Summary No./CompID/System	Scope / Method / Procedure	Dwg/ISO No. Comp. Desc. Code Case		Period 1		Period 2			Period 3	
					2VR13	2VR14	2VR14A	2VR15	2VR16	2VR17	2VR18
2	1205			OWN	-	-	-	-	-	-	-
				PRE	-	-	-	-	-	-	-
C-F-1	V2 21205-005-29		ISI-21205-005	ISI	-	-	-	-	-	-	-
C5.11	21205-005-29		14" PIPE TO HEAT EXCHANGER	AUG	-	-	-	-	-	-	-
2	1205		NOZZLE (AI 87-0131)	OWN	-	-	-	-	-	-	-
				PRE	-	-	-	-	-	-	-
C-F-1	V2 21205-005-3		ISI-21205-005	ISI	-	-	-	-	-	-	-
C5.11	21205-005-3		8" VALVE TO PIPE	AUG	-	-	-	-	-	-	-
2	1205			OWN	-	-	-	-	-	-	-
				PRE	-	-	-	-	-	-	-
C-F-1	V2 21205-005-30		ISI-21205-005	ISI	-	-	-	-	-	-	-
C5.11	21205-005-30		8" TEE TO PIPE	AUG	-	-	-	-	-	-	-
2	1205			OWN	-	-	-	-	-	-	-
				PRE	-	-	-	-	-	-	-
C-F-1	V2 21205-005-31		ISI-21205-005	ISI	-	-	-	-	-	-	-
C5.11	21205-005-31		8" PIPE TO ELBOW	AUG	-	-	-	-	-	-	-
2	1205			OWN	-	-	-	-	-	-	-
				PRE	-	-	-	-	-	-	-
C-F-1	V2 21205-005-32		ISI-21205-005	ISI	-	-	-	-	-	-	-
C5.11	21205-005-32		8" ELBOW TO PIPE	AUG	-	-	-	-	-	-	-
2	1205			OWN	-	-	-	-	-	-	-
				PRE	-	-	-	-	-	-	-
C-F-1	V2 21205-005-32 A		ISI-21205-005	ISI	-	-	-	-	-	-	-
C5.11	21205-005-32 A		8" PIPE TO PIPE	AUG	-	-	-	-	-	-	-
2	1205			OWN	-	-	-	-	-	-	-
				PRE	-	-	-	-	-	-	-
C-F-1	V2 21205-005-33		ISI-21205-005	ISI	-	-	-	-	-	-	-
C5.11	21205-005-33		8" PIPE TO ELBOW	AUG	-	-	-	-	-	-	-
2	1205			OWN	-	-	-	-	-	-	-
				PRE	-	-	-	-	-	-	-
C-F-1	V2 21205-005-34	ISI/UT/	ISI-21205-005	ISI	-	-	-	s	-	-	-
C5.11	21205-005-34		8" ELBOW TO PIPE	AUG	-	-	-	-	-	-	-
2	1205			OWN	-	-	-	-	-	-	-
				PRE	-	-	-	-	-	-	-
C-F-1	V2 21205-005-35	ISI/UT/	ISI-21205-005	ISI	-	-	-	s	-	-	-
C5.11	21205-005-35		8" PIPE TO ELBOW	AUG	-	-	-	-	-	-	-
2	1205			OWN	-	-	-	-	-	-	-
				PRE	-	-	-	-	-	-	-
C-F-1	V2 21205-005-36		ISI-21205-005	ISI	-	-	-	-	-	-	-

Southern Nuclear Operating Company
3rd Interval
VOGTLE-2 ISI PLAN, VERSION 3.0

Category, Item No., Class	Summary No./ComplD/System	Scope / Method / Procedure	Dwg/ISO No. Comp. Desc. Code Case		Period 1		Period 2			Period 3	
					2VR13	2VR14	2VR14A	2VR15	2VR16	2VR17	2VR18
C5.11 2	21205-005-36 1205		8" ELBOW TO PIPE	AUG OWN PRE	-	-	-	-	-	-	-
C-F-1 C5.11 2	V2 21205-005-39 21205-005-39 1205		ISI-21205-005 8" PIPE TO FLANGE	ISI AUG OWN PRE	-	-	-	-	-	-	-
C-F-1 C5.11 2	V2 21205-005-4 21205-005-4 1205		ISI-21205-005 8" PIPE TO ELBOW	ISI AUG OWN PRE	-	-	-	-	-	-	-
C-F-1 C5.11 2	V2 21205-005-5 21205-005-5 1205		ISI-21205-005 8" ELBOW TO PIPE	ISI AUG OWN PRE	-	-	-	-	-	-	-
C-F-1 C5.11 2	V2 21205-005-6 21205-005-6 1205		ISI-21205-005 8" PIPE TO ELBOW	ISI AUG OWN PRE	-	-	-	-	-	-	-
C-F-1 C5.11 2	V2 21205-005-7 21205-005-7 1205		ISI-21205-005 8" ELBOW TO PIPE	ISI AUG OWN PRE	-	-	-	-	-	-	-
C-F-1 C5.11 2	V2 21205-005-8 21205-005-8 1205		ISI-21205-005 8" PIPE TO FLANGE	ISI AUG OWN PRE	-	-	-	-	-	-	-
C-F-1 C5.11 2	V2 21205-005-9 21205-005-9 1205		ISI-21205-005 8" FLANGE TO PIPE	ISI AUG OWN PRE	-	-	-	-	-	-	-
C-F-1 C5.11 2	V2 21205-006-1 21205-006-1 1205		ISI-21205-006 8" PUMP NOZZLE TO PIPE	ISI AUG OWN PRE	-	-	-	-	-	-	-
C-F-1 C5.11 2	V2 21205-006-10 21205-006-10 1205		ISI-21205-006 8" PIPE TO ELBOW	ISI AUG OWN PRE	-	-	-	-	-	-	-
C-F-1	V2 21205-006-11	ISI/UT/	ISI-21205-006	ISI	-	-	-	-	-	s	-

Southern Nuclear Operating Company
3rd Interval
VOGTLE-2 ISI PLAN, VERSION 3.0

Category, Item No., Class	Summary No./ComplD/System	Scope / Method / Procedure	Dwg/ISO No. Comp. Desc. Code Case		Period 1		Period 2			Period 3	
					2VR13	2VR14	2VR14A	2VR15	2VR16	2VR17	2VR18
C5.11 2	21205-006-11 1205		8" ELBOW TO PIPE	AUG OWN PRE	-	-	-	-	-	-	-
C-F-1 C5.11 2	V2 21205-006-13 21205-006-13 1205	ISI/UT/	ISI-21205-006 8" PIPE TO ELBOW	ISI AUG OWN PRE	-	-	-	-	-	s	-
C-F-1 C5.11 2	V2 21205-006-14 21205-006-14 1205		ISI-21205-006 8" ELBOW TO PIPE	ISI AUG OWN PRE	-	-	-	-	-	-	-
C-F-1 C5.11 2	V2 21205-006-15 21205-006-15 1205		ISI-21205-006 8" PIPE TO TEE	ISI AUG OWN PRE	-	-	-	-	-	-	-
C-F-1 C5.11 2	V2 21205-006-16 21205-006-16 1205		ISI-21205-006 8" TEE TO PIPE	ISI AUG OWN PRE	-	-	-	-	-	-	-
C-F-1 C5.11 2	V2 21205-006-17 21205-006-17 1205		ISI-21205-006 8" PIPE TO PIPE	ISI AUG OWN PRE	-	-	-	-	-	-	-
C-F-1 C5.11 2	V2 21205-006-18 21205-006-18 1205		ISI-21205-006 8" PIPE TO ELBOW	ISI AUG OWN PRE	-	-	-	-	-	-	-
C-F-1 C5.11 2	V2 21205-006-19 21205-006-19 1205		ISI-21205-006 8" ELBOW TO PIPE	ISI AUG OWN PRE	-	-	-	-	-	-	-
C-F-1 C5.11 2	V2 21205-006-2 21205-006-2 1205		ISI-21205-006 8" PIPE TO VALVE	ISI AUG OWN PRE	-	-	-	-	-	-	-
C-F-1 C5.11 2	V2 21205-006-21 21205-006-21 1205		ISI-21205-006 8" PIPE TO VALVE	ISI AUG OWN PRE	-	-	-	-	-	-	-
C-F-1	V2 21205-006-22		ISI-21205-006	ISI	-	-	-	-	-	-	-

Southern Nuclear Operating Company
3rd Interval
VOGTLE-2 ISI PLAN, VERSION 3.0

Category, Item No., Class	Summary No./ComplID/System	Scope / Method / Procedure	Dwg/ISO No. Comp. Desc. Code Case		Period 1		Period 2			Period 3	
					2VR13	2VR14	2VR14A	2VR15	2VR16	2VR17	2VR18
C5.11 2	21205-006-22 1205		8" VALVE TO PIPE	AUG OWN PRE	-	-	-	-	-	-	-
C-F-1 C5.11 2	V2 21205-006-23 21205-006-23 1205		ISI-21205-006 8" PIPE TO ELBOW	ISI AUG OWN PRE	-	-	-	-	-	-	-
C-F-1 C5.11 2	V2 21205-006-24 21205-006-24 1205		ISI-21205-006 8" ELBOW TO PIPE	ISI AUG OWN PRE	-	-	-	-	-	-	-
C-F-1 C5.11 2	V2 21205-006-25 21205-006-25 1205		ISI-21205-006 8" PIPE TO REDUCER	ISI AUG OWN PRE	-	-	-	-	-	-	-
C-F-1 C5.11 2	V2 21205-006-26 21205-006-26 1205		ISI-21205-006 14" REDUCER TO PIPE	ISI AUG OWN PRE	-	-	-	-	-	-	-
C-F-1 C5.11 2	V2 21205-006-27 21205-006-27 1205		ISI-21205-006 14" PIPE TO ELBOW	ISI AUG OWN PRE	-	-	-	-	-	-	-
C-F-1 C5.11 2	V2 21205-006-28 21205-006-28 1205		ISI-21205-006 14" ELBOW TO PIPE	ISI AUG OWN PRE	-	-	-	-	-	-	-
C-F-1 C5.11 2	V2 21205-006-29 21205-006-29 1205		ISI-21205-006 14" PIPE TO HEAT EXCHANGER NOZZLE	ISI AUG OWN PRE	-	-	-	-	-	-	-
C-F-1 C5.11 2	V2 21205-006-3 21205-006-3 1205		ISI-21205-006 8" VALVE TO PIPE	ISI AUG OWN PRE	-	-	-	-	-	-	-
C-F-1 C5.11 2	V2 21205-006-30 21205-006-30 1205		ISI-21205-006 8" TEE TO PIPE	ISI AUG OWN PRE	-	-	-	-	-	-	-

Southern Nuclear Operating Company
3rd Interval
VOGTLE-2 ISI PLAN, VERSION 3.0

Category, Item No., Class	Summary No./Compld/System	Scope / Method / Procedure	Dwg/ISO No. Comp. Desc. Code Case		Period 1		Period 2			Period 3	
					2VR13	2VR14	2VR14A	2VR15	2VR16	2VR17	2VR18
C-F-1 C5.11 2	V2 21205-006-31 21205-006-31 1205		ISI-21205-006 8" PIPE TO ELBOW	ISI AUG OWN PRE	-	-	-	-	-	-	-
C-F-1 C5.11 2	V2 21205-006-32 21205-006-32 1205		ISI-21205-006 8" ELBOW TO PIPE	ISI AUG OWN PRE	-	-	-	-	-	-	-
C-F-1 C5.11 2	V2 21205-006-33 21205-006-33 1205		ISI-21205-006 8" PIPE TO PIPE	ISI AUG OWN PRE	-	-	-	-	-	-	-
C-F-1 C5.11 2	V2 21205-006-34 21205-006-34 1205		ISI-21205-006 8" PIPE TO ELBOW	ISI AUG OWN PRE	-	-	-	-	-	-	-
C-F-1 C5.11 2	V2 21205-006-35 21205-006-35 1205		ISI-21205-006 8" ELBOW TO PIPE	ISI AUG OWN PRE	-	-	-	-	-	-	-
C-F-1 C5.11 2	V2 21205-006-37 21205-006-37 1205		ISI-21205-006 8" PIPE TO ELBOW	ISI AUG OWN PRE	-	-	-	-	-	-	-
C-F-1 C5.11 2	V2 21205-006-38 21205-006-38 1205		ISI-21205-006 8" ELBOW TO PIPE	ISI AUG OWN PRE	-	-	-	-	-	-	-
C-F-1 C5.11 2	V2 21205-006-4 21205-006-4 1205	ISI/UT/	ISI-21205-006 8" PIPE TO ELBOW (AI 87-0131)	ISI AUG OWN PRE	-	-	-	s	-	-	-
C-F-1 C5.11 2	V2 21205-006-41 21205-006-41 1205		ISI-21205-006 8" PIPE TO FLANGE	ISI AUG OWN PRE	-	-	-	-	-	-	-
C-F-1 C5.11 2	V2 21205-006-5 21205-006-5 1205		ISI-21205-006 8" ELBOW TO PIPE	ISI AUG OWN PRE	-	-	-	-	-	-	-

Southern Nuclear Operating Company
3rd Interval
VOGTLE-2 ISI PLAN, VERSION 3.0

Category, Item No., Class	Summary No./ComplD/System	Scope / Method / Procedure	Dwg/ISO No. Comp. Desc. Code Case		Period 1		Period 2			Period 3	
					2VR13	2VR14	2VR14A	2VR15	2VR16	2VR17	2VR18
C-F-1 C5.11 2	V2 21205-006-6 21205-006-6 1205		ISI-21205-006 8" PIPE TO ELBOW	ISI AUG OWN PRE	-	-	-	-	-	-	-
C-F-1 C5.11 2	V2 21205-006-7 21205-006-7 1205		ISI-21205-006 8" ELBOW TO PIPE	ISI AUG OWN PRE	-	-	-	-	-	-	-
C-F-1 C5.11 2	V2 21205-006-8 21205-006-8 1205		ISI-21205-006 8" PIPE TO FLANGE	ISI AUG OWN PRE	-	-	-	-	-	-	-
C-F-1 C5.11 2	V2 21205-006-9 21205-006-9 1205		ISI-21205-006 8" FLANGE TO PIPE	ISI AUG OWN PRE	-	-	-	-	-	-	-
C-F-1 C5.11 2	V2 21205-007-1 21205-007-1 1205		ISI-21205-007 14" HEAT EXCHANGER NOZZLE TO PIPE (AI 87-0131)	ISI AUG OWN PRE	-	-	-	-	-	-	-
C-F-1 C5.11 2	V2 21205-007-10 21205-007-10 1205		ISI-21205-007 8" ELBOW TO PIPE	ISI AUG OWN PRE	-	-	-	-	-	-	-
C-F-1 C5.11 2	V2 21205-007-11 21205-007-11 1205		ISI-21205-007 8" PIPE TO TEE	ISI AUG OWN PRE	-	-	-	-	-	-	-
C-F-1 C5.11 2	V2 21205-007-12 21205-007-12 1205		ISI-21205-007 8" FLANGE TO PIPE	ISI AUG OWN PRE	-	-	-	-	-	-	-
C-F-1 C5.11 2	V2 21205-007-13 21205-007-13 1205		ISI-21205-007 8" PIPE TO ELBOW	ISI AUG OWN PRE	-	-	-	-	-	-	-
C-F-1 C5.11 2	V2 21205-007-14 21205-007-14 1205		ISI-21205-007 8" ELBOW TO PIPE	ISI AUG OWN	-	-	-	-	-	-	-

Southern Nuclear Operating Company
3rd Interval
VOGTLE-2 ISI PLAN, VERSION 3.0

Category, Item No., Class	Summary No./CompID/System	Scope / Method / Procedure	Dwg/ISO No. Comp. Desc. Code Case		Period 1		Period 2			Period 3	
					2VR13	2VR14	2VR14A	2VR15	2VR16	2VR17	2VR18
C-F-1	V2 21205-007-15		ISI-21205-007	PRE	-	-	-	-	-	-	-
C5.11	21205-007-15		8" PIPE TO ELBOW	ISI	-	-	-	-	-	-	-
2	1205			AUG	-	-	-	-	-	-	-
				OWN	-	-	-	-	-	-	-
				PRE	-	-	-	-	-	-	-
C-F-1	V2 21205-007-16	ISI/UT/	ISI-21205-007	ISI	-	-	-	-	-	s	-
C5.11	21205-007-16		8" ELBOW TO PIPE (AI 87-0131)	AUG	-	-	-	-	-	-	-
2	1205			OWN	-	-	-	-	-	-	-
				PRE	-	-	-	-	-	-	-
C-F-1	V2 21205-007-17		ISI-21205-007	ISI	-	-	-	-	-	-	-
C5.11	21205-007-17		8" PIPE TO TEE	AUG	-	-	-	-	-	-	-
2	1205			OWN	-	-	-	-	-	-	-
				PRE	-	-	-	-	-	-	-
C-F-1	V2 21205-007-18	ISI/UT/NMP-ES-024-501	ISI-21205-007	ISI	c	-	-	-	-	-	-
C5.11	21205-007-18	ISI/UT/NMP-ES-024-501	8" TEE TO PIPE	AUG	-	-	-	-	-	-	-
2	1205			OWN	-	-	-	-	-	-	-
				PRE	-	-	-	-	-	-	-
C-F-1	V2 21205-007-19		ISI-21205-007	ISI	-	-	-	-	-	-	-
C5.11	21205-007-19		8" PIPE TO FLANGE	AUG	-	-	-	-	-	-	-
2	1205			OWN	-	-	-	-	-	-	-
				PRE	-	-	-	-	-	-	-
C-F-1	V2 21205-007-2		ISI-21205-007	ISI	-	-	-	-	-	-	-
C5.11	21205-007-2		14" PIPE TO REDUCER	AUG	-	-	-	-	-	-	-
2	1205			OWN	-	-	-	-	-	-	-
				PRE	-	-	-	-	-	-	-
C-F-1	V2 21205-007-20		ISI-21205-007	ISI	-	-	-	-	-	-	-
C5.11	21205-007-20		8" FLANGE TO PIPE	AUG	-	-	-	-	-	-	-
2	1205			OWN	-	-	-	-	-	-	-
				PRE	-	-	-	-	-	-	-
C-F-1	V2 21205-007-21		ISI-21205-007	ISI	-	-	-	-	-	-	-
C5.11	21205-007-21		8" PIPE TO ELBOW	AUG	-	-	-	-	-	-	-
2	1205			OWN	-	-	-	-	-	-	-
				PRE	-	-	-	-	-	-	-
C-F-1	V2 21205-007-22		ISI-21205-007	ISI	-	-	-	-	-	-	-
C5.11	21205-007-22		8" ELBOW TO PIPE	AUG	-	-	-	-	-	-	-
2	1205			OWN	-	-	-	-	-	-	-
				PRE	-	-	-	-	-	-	-
C-F-1	V2 21205-007-23		ISI-21205-007	ISI	-	-	-	-	-	-	-
C5.11	21205-007-23		8" PIPE TO TEE	AUG	-	-	-	-	-	-	-
2	1205			OWN	-	-	-	-	-	-	-

Southern Nuclear Operating Company
3rd Interval
VOGTLE-2 ISI PLAN, VERSION 3.0

Category, Item No., Class	Summary No./CompID/System	Scope / Method / Procedure	Dwg/ISO No. Comp. Desc. Code Case		Period 1		Period 2			Period 3	
					2VR13	2VR14	2VR14A	2VR15	2VR16	2VR17	2VR18
C-F-1	V2 21205-007-24		ISI-21205-007	ISI	-	-	-	-	-	-	-
C5.11	21205-007-24		8" TEE TO PIPE	AUG	-	-	-	-	-	-	-
2	1205			OWN	-	-	-	-	-	-	-
				PRE	-	-	-	-	-	-	-
C-F-1	V2 21205-007-27		ISI-21205-007	ISI	-	-	-	-	-	-	-
C5.11	21205-007-27		8" PIPE TO PIPE	AUG	-	-	-	-	-	-	-
2	1205			OWN	-	-	-	-	-	-	-
				PRE	-	-	-	-	-	-	-
C-F-1	V2 21205-007-28		ISI-21205-007	ISI	-	-	-	-	-	-	-
C5.11	21205-007-28		8" PIPE TO ELBOW	AUG	-	-	-	-	-	-	-
2	1205			OWN	-	-	-	-	-	-	-
				PRE	-	-	-	-	-	-	-
C-F-1	V2 21205-007-29		ISI-21205-007	ISI	-	-	-	-	-	-	-
C5.11	21205-007-29		8" ELBOW TO PIPE	AUG	-	-	-	-	-	-	-
2	1205			OWN	-	-	-	-	-	-	-
				PRE	-	-	-	-	-	-	-
C-F-1	V2 21205-007-3		ISI-21205-007	ISI	-	-	-	-	-	-	-
C5.11	21205-007-3		8" REDUCER TO PIPE	AUG	-	-	-	-	-	-	-
2	1205			OWN	-	-	-	-	-	-	-
				PRE	-	-	-	-	-	-	-
C-F-1	V2 21205-007-30		ISI-21205-007	ISI	-	-	-	-	-	-	-
C5.11	21205-007-30		8" PIPE TO ELBOW	AUG	-	-	-	-	-	-	-
2	1205			OWN	-	-	-	-	-	-	-
				PRE	-	-	-	-	-	-	-
C-F-1	V2 21205-007-31		ISI-21205-007	ISI	-	-	-	-	-	-	-
C5.11	21205-007-31		8" ELBOW TO PIPE	AUG	-	-	-	-	-	-	-
2	1205			OWN	-	-	-	-	-	-	-
				PRE	-	-	-	-	-	-	-
C-F-1	V2 21205-007-32		ISI-21205-007	ISI	-	-	-	-	-	-	-
C5.11	21205-007-32		8" PIPE TO PIPE	AUG	-	-	-	-	-	-	-
2	1205			OWN	-	-	-	-	-	-	-
				PRE	-	-	-	-	-	-	-
C-F-1	V2 21205-007-33		ISI-21205-007	ISI	-	-	-	-	-	-	-
C5.11	21205-007-33		8" PIPE TO PIPE	AUG	-	-	-	-	-	-	-
2	1205			OWN	-	-	-	-	-	-	-
				PRE	-	-	-	-	-	-	-
C-F-1	V2 21205-007-35		ISI-21205-007	ISI	-	-	-	-	-	-	-
C5.11	21205-007-35		8" PIPE TO PIPE	AUG	-	-	-	-	-	-	-
2	1205			OWN	-	-	-	-	-	-	-

Southern Nuclear Operating Company
3rd Interval
VOGTLE-2 ISI PLAN, VERSION 3.0

Category, Item No., Class	Summary No./ComplD/System	Scope / Method / Procedure	Dwg/ISO No. Comp. Desc. Code Case		Period 1		Period 2			Period 3	
					2VR13	2VR14	2VR14A	2VR15	2VR16	2VR17	2VR18
				PRE	-	-	-	-	-	-	-
C-F-1	V2 21205-007-36		ISI-21205-007	ISI	-	-	-	-	-	-	-
C5.11	21205-007-36		8" PIPE TO ELBOW	AUG	-	-	-	-	-	-	-
2	1205			OWN	-	-	-	-	-	-	-
				PRE	-	-	-	-	-	-	-
C-F-1	V2 21205-007-37		ISI-21205-007	ISI	-	-	-	-	-	-	-
C5.11	21205-007-37		8" ELBOW TO PIPE	AUG	-	-	-	-	-	-	-
2	1205			OWN	-	-	-	-	-	-	-
				PRE	-	-	-	-	-	-	-
C-F-1	V2 21205-007-38		ISI-21205-007	ISI	-	-	-	-	-	-	-
C5.11	21205-007-38		8" PIPE TO ELBOW	AUG	-	-	-	-	-	-	-
2	1205			OWN	-	-	-	-	-	-	-
				PRE	-	-	-	-	-	-	-
C-F-1	V2 21205-007-39		ISI-21205-007	ISI	-	-	-	-	-	-	-
C5.11	21205-007-39		8" ELBOW TO PIPE	AUG	-	-	-	-	-	-	-
2	1205			OWN	-	-	-	-	-	-	-
				PRE	-	-	-	-	-	-	-
C-F-1	V2 21205-007-4		ISI-21205-007	ISI	-	-	-	-	-	-	-
C5.11	21205-007-4		8" PIPE TO PIPE	AUG	-	-	-	-	-	-	-
2	1205			OWN	-	-	-	-	-	-	-
				PRE	-	-	-	-	-	-	-
C-F-1	V2 21205-007-40		ISI-21205-007	ISI	-	-	-	-	-	-	-
C5.11	21205-007-40		8" PIPE TO PIPE	AUG	-	-	-	-	-	-	-
2	1205			OWN	-	-	-	-	-	-	-
				PRE	-	-	-	-	-	-	-
C-F-1	V2 21205-007-41		ISI-21205-007	ISI	-	-	-	-	-	-	-
C5.11	21205-007-41		8" PIPE TO ELBOW	AUG	-	-	-	-	-	-	-
2	1205			OWN	-	-	-	-	-	-	-
				PRE	-	-	-	-	-	-	-
C-F-1	V2 21205-007-42		ISI-21205-007	ISI	-	-	-	-	-	-	-
C5.11	21205-007-42		8" ELBOW TO PIPE	AUG	-	-	-	-	-	-	-
2	1205			OWN	-	-	-	-	-	-	-
				PRE	-	-	-	-	-	-	-
C-F-1	V2 21205-007-43		ISI-21205-007	ISI	-	-	-	-	-	-	-
C5.11	21205-007-43		8" PIPE TO ELBOW	AUG	-	-	-	-	-	-	-
2	1205			OWN	-	-	-	-	-	-	-
				PRE	-	-	-	-	-	-	-
C-F-1	V2 21205-007-44		ISI-21205-007	ISI	-	-	-	-	-	-	-
C5.11	21205-007-44		8" ELBOW TO PIPE	AUG	-	-	-	-	-	-	-
2	1205			OWN	-	-	-	-	-	-	-

Southern Nuclear Operating Company
3rd Interval
VOGTLE-2 ISI PLAN, VERSION 3.0

Category, Item No., Class	Summary No./ComplID/System	Scope / Method / Procedure	Dwg/ISO No. Comp. Desc. Code Case		Period 1		Period 2			Period 3	
					2VR13	2VR14	2VR14A	2VR15	2VR16	2VR17	2VR18
C-F-1	V2 21205-007-45		ISI-21205-007	PRE	-	-	-	-	-	-	-
C5.11	21205-007-45		8" PIPE TO PIPE	ISI	-	-	-	-	-	-	-
2	1205			AUG	-	-	-	-	-	-	-
				OWN	-	-	-	-	-	-	-
				PRE	-	-	-	-	-	-	-
C-F-1	V2 21205-007-46		ISI-21205-007	ISI	-	-	-	-	-	-	-
C5.11	21205-007-46		8" PIPE TO PIPE	AUG	-	-	-	-	-	-	-
2	1205			OWN	-	-	-	-	-	-	-
				PRE	-	-	-	-	-	-	-
C-F-1	V2 21205-007-47		ISI-21205-007	ISI	-	-	-	-	-	-	-
C5.11	21205-007-47		8" PIPE TO PIPE	AUG	-	-	-	-	-	-	-
2	1205			OWN	-	-	-	-	-	-	-
				PRE	-	-	-	-	-	-	-
C-F-1	V2 21205-007-48		ISI-21205-007	ISI	-	-	-	-	-	-	-
C5.11	21205-007-48		8" PIPE TO ELBOW	AUG	-	-	-	-	-	-	-
2	1205			OWN	-	-	-	-	-	-	-
				PRE	-	-	-	-	-	-	-
C-F-1	V2 21205-007-49		ISI-21205-007	ISI	-	-	-	-	-	-	-
C5.11	21205-007-49		8" ELBOW TO PIPE	AUG	-	-	-	-	-	-	-
2	1205			OWN	-	-	-	-	-	-	-
				PRE	-	-	-	-	-	-	-
C-F-1	V2 21205-007-5		ISI-21205-007	ISI	-	-	-	-	-	-	-
C5.11	21205-007-5		8" PIPE TO ELBOW	AUG	-	-	-	-	-	-	-
2	1205			OWN	-	-	-	-	-	-	-
				PRE	-	-	-	-	-	-	-
C-F-1	V2 21205-007-50		ISI-21205-007	ISI	-	-	-	-	-	-	-
C5.11	21205-007-50		8" PIPE TO ELBOW	AUG	-	-	-	-	-	-	-
2	1205			OWN	-	-	-	-	-	-	-
				PRE	-	-	-	-	-	-	-
C-F-1	V2 21205-007-51		ISI-21205-007	ISI	-	-	-	-	-	-	-
C5.11	21205-007-51		8" ELBOW TO PIPE	AUG	-	-	-	-	-	-	-
2	1205			OWN	-	-	-	-	-	-	-
				PRE	-	-	-	-	-	-	-
C-F-1	V2 21205-007-52		ISI-21205-007	ISI	-	-	-	-	-	-	-
C5.11	21205-007-52		8" PIPE TO ELBOW	AUG	-	-	-	-	-	-	-
2	1205			OWN	-	-	-	-	-	-	-
				PRE	-	-	-	-	-	-	-
C-F-1	V2 21205-007-53		ISI-21205-007	ISI	-	-	-	-	-	-	-
C5.11	21205-007-53		8" ELBOW TO PIPE	AUG	-	-	-	-	-	-	-
2	1205			OWN	-	-	-	-	-	-	-

Southern Nuclear Operating Company
3rd Interval
VOGTLE-2 ISI PLAN, VERSION 3.0

Category, Item No., Class	Summary No./CompID/System	Scope / Method / Procedure	Dwg/ISO No. Comp. Desc. Code Case		Period 1		Period 2			Period 3	
					2VR13	2VR14	2VR14A	2VR15	2VR16	2VR17	2VR18
C-F-1	V2 21205-007-54	ISI/UT/	ISI-21205-007	PRE	-	-	-	-	-	-	-
C5.11	21205-007-54		8" PIPE TO ELBOW (AI 87-0131)	ISI	-	-	-	s	-	-	-
2	1205			AUG	-	-	-	-	-	-	-
				OWN	-	-	-	-	-	-	-
				PRE	-	-	-	-	-	-	-
C-F-1	V2 21205-007-55	ISI/UT/	ISI-21205-007	ISI	-	-	-	s	-	-	-
C5.11	21205-007-55		8" ELBOW TO PIPE (AI 87-0131)	AUG	-	-	-	-	-	-	-
2	1205			OWN	-	-	-	-	-	-	-
				PRE	-	-	-	-	-	-	-
C-F-1	V2 21205-007-56		ISI-21205-007	ISI	-	-	-	-	-	-	-
C5.11	21205-007-56		8" PIPE TO PIPE	AUG	-	-	-	-	-	-	-
2	1205			OWN	-	-	-	-	-	-	-
				PRE	-	-	-	-	-	-	-
C-F-1	V2 21205-007-56 A		ISI-21205-007	ISI	-	-	-	-	-	-	-
C5.11	21205-007-56 A		8" PIPE TO PIPE	AUG	-	-	-	-	-	-	-
2	1205			OWN	-	-	-	-	-	-	-
				PRE	-	-	-	-	-	-	-
C-F-1	V2 21205-007-57		ISI-21205-007	ISI	-	-	-	-	-	-	-
C5.11	21205-007-57		8" PIPE TO VALVE	AUG	-	-	-	-	-	-	-
2	1205			OWN	-	-	-	-	-	-	-
				PRE	-	-	-	-	-	-	-
C-F-1	V2 21205-007-58		ISI-21205-007	ISI	-	-	-	-	-	-	-
C5.11	21205-007-58		8" TEE TO PIPE	AUG	-	-	-	-	-	-	-
2	1205			OWN	-	-	-	-	-	-	-
				PRE	-	-	-	-	-	-	-
C-F-1	V2 21205-007-59	ISI/UT/	ISI-21205-007	ISI	-	-	-	-	-	s	-
C5.11	21205-007-59		8" PIPE TO TEE (AI 87-0131)	AUG	-	-	-	-	-	-	-
2	1205			OWN	-	-	-	-	-	-	-
				PRE	-	-	-	-	-	-	-
C-F-1	V2 21205-007-6		ISI-21205-007	ISI	-	-	-	-	-	-	-
C5.11	21205-007-6		8" ELBOW TO PIPE	AUG	-	-	-	-	-	-	-
2	1205			OWN	-	-	-	-	-	-	-
				PRE	-	-	-	-	-	-	-
C-F-1	V2 21205-007-60	ISI/UT/	ISI-21205-007	ISI	-	-	-	-	-	s	-
C5.11	21205-007-60		8" TEE TO PIPE (AI 87-0131)	AUG	-	-	-	-	-	-	-
2	1205			OWN	-	-	-	-	-	-	-
				PRE	-	-	-	-	-	-	-
C-F-1	V2 21205-007-61		ISI-21205-007	ISI	-	-	-	-	-	-	-
C5.11	21205-007-61		8" PIPE TO VALVE	AUG	-	-	-	-	-	-	-
2	1205			OWN	-	-	-	-	-	-	-

Southern Nuclear Operating Company
3rd Interval
VOGTLE-2 ISI PLAN, VERSION 3.0

Category, Item No., Class	Summary No./ComplID/System	Scope / Method / Procedure	Dwg/ISO No. Comp. Desc. Code Case		Period 1		Period 2			Period 3	
					2VR13	2VR14	2VR14A	2VR15	2VR16	2VR17	2VR18
C-F-1	V2 21205-007-62		ISI-21205-007	ISI	-	-	-	-	-	-	-
C5.11	21205-007-62		8" TEE TO PIPE	AUG	-	-	-	-	-	-	-
2	1205			OWN	-	-	-	-	-	-	-
				PRE	-	-	-	-	-	-	-
C-F-1	V2 21205-007-63		ISI-21205-007	ISI	-	-	-	-	-	-	-
C5.11	21205-007-63		8" PIPE TO ELBOW	AUG	-	-	-	-	-	-	-
2	1205			OWN	-	-	-	-	-	-	-
				PRE	-	-	-	-	-	-	-
C-F-1	V2 21205-007-64		ISI-21205-007	ISI	-	-	-	-	-	-	-
C5.11	21205-007-64		8" ELBOW TO PIPE	AUG	-	-	-	-	-	-	-
2	1205			OWN	-	-	-	-	-	-	-
				PRE	-	-	-	-	-	-	-
C-F-1	V2 21205-007-65		ISI-21205-007	ISI	-	-	-	-	-	-	-
C5.11	21205-007-65		8" PIPE TO PIPE	AUG	-	-	-	-	-	-	-
2	1205			OWN	-	-	-	-	-	-	-
				PRE	-	-	-	-	-	-	-
C-F-1	V2 21205-007-66		ISI-21205-007	ISI	-	-	-	-	-	-	-
C5.11	21205-007-66		8" PIPE TO PIPE	AUG	-	-	-	-	-	-	-
2	1205			OWN	-	-	-	-	-	-	-
				PRE	-	-	-	-	-	-	-
C-F-1	V2 21205-007-66 A		ISI-21205-007	ISI	-	-	-	-	-	-	-
C5.11	21205-007-66 A		8" PIPE TO ELBOW	AUG	-	-	-	-	-	-	-
2	1205			OWN	-	-	-	-	-	-	-
				PRE	-	-	-	-	-	-	-
C-F-1	V2 21205-007-67		ISI-21205-007	ISI	-	-	-	-	-	-	-
C5.11	21205-007-67		8" ELBOW TO PIPE	AUG	-	-	-	-	-	-	-
2	1205			OWN	-	-	-	-	-	-	-
				PRE	-	-	-	-	-	-	-
C-F-1	V2 21205-007-69 A		ISI-21205-007	ISI	-	-	-	-	-	-	-
C5.11	21205-007-69 A		8" PIPE TO PIPE	AUG	-	-	-	-	-	-	-
2	1205			OWN	-	-	-	-	-	-	-
				PRE	-	-	-	-	-	-	-
C-F-1	V2 21205-007-7		ISI-21205-007	ISI	-	-	-	-	-	-	-
C5.11	21205-007-7		8" PIPE TO FLANGE	AUG	-	-	-	-	-	-	-
2	1205			OWN	-	-	-	-	-	-	-
				PRE	-	-	-	-	-	-	-
C-F-1	V2 21205-007-70		ISI-21205-007	ISI	-	-	-	-	-	-	-
C5.11	21205-007-70		8" PIPE TO ELBOW	AUG	-	-	-	-	-	-	-
2	1205			OWN	-	-	-	-	-	-	-

Southern Nuclear Operating Company
3rd Interval
VOGTLE-2 ISI PLAN, VERSION 3.0

Category, Item No., Class	Summary No./CompID/System	Scope / Method / Procedure	Dwg/ISO No. Comp. Desc. Code Case		Period 1		Period 2			Period 3	
					2VR13	2VR14	2VR14A	2VR15	2VR16	2VR17	2VR18
C-F-1	V2 21205-007-71		ISI-21205-007	PRE	-	-	-	-	-	-	-
C5.11	21205-007-71		8" ELBOW TO PIPE	ISI	-	-	-	-	-	-	-
2	1205			AUG	-	-	-	-	-	-	-
				OWN	-	-	-	-	-	-	-
				PRE	-	-	-	-	-	-	-
C-F-1	V2 21205-007-73		ISI-21205-007	ISI	-	-	-	-	-	-	-
C5.11	21205-007-73		8" PIPE TO ELBOW	AUG	-	-	-	-	-	-	-
2	1205			OWN	-	-	-	-	-	-	-
				PRE	-	-	-	-	-	-	-
C-F-1	V2 21205-007-74		ISI-21205-007	ISI	-	-	-	-	-	-	-
C5.11	21205-007-74		8" ELBOW TO PIPE	AUG	-	-	-	-	-	-	-
2	1205			OWN	-	-	-	-	-	-	-
				PRE	-	-	-	-	-	-	-
C-F-1	V2 21205-007-75		ISI-21205-007	ISI	-	-	-	-	-	-	-
C5.11	21205-007-75		8" PIPE TO VALVE	AUG	-	-	-	-	-	-	-
2	1205			OWN	-	-	-	-	-	-	-
				PRE	-	-	-	-	-	-	-
C-F-1	V2 21205-007-8		ISI-21205-007	ISI	-	-	-	-	-	-	-
C5.11	21205-007-8		8" FLANGE TO PIPE	AUG	-	-	-	-	-	-	-
2	1205			OWN	-	-	-	-	-	-	-
				PRE	-	-	-	-	-	-	-
C-F-1	V2 21205-007-9		ISI-21205-007	ISI	-	-	-	-	-	-	-
C5.11	21205-007-9		8" PIPE TO ELBOW	AUG	-	-	-	-	-	-	-
2	1205			OWN	-	-	-	-	-	-	-
				PRE	-	-	-	-	-	-	-
C-F-1	V2 21205-008-1		ISI-21205-008	ISI	-	-	-	-	-	-	-
C5.11	21205-008-1		14" NOZZLE HEAT EXCHANGER TO PIPE (AI 87-0131)	AUG	-	-	-	-	-	-	-
2	1205			OWN	-	-	-	-	-	-	-
				PRE	-	-	-	-	-	-	-
C-F-1	V2 21205-008-10		ISI-21205-008	ISI	-	-	-	-	-	-	-
C5.11	21205-008-10		8" PIPE TO TEE	AUG	-	-	-	-	-	-	-
2	1205			OWN	-	-	-	-	-	-	-
				PRE	-	-	-	-	-	-	-
C-F-1	V2 21205-008-11		ISI-21205-008	ISI	-	-	-	-	-	-	-
C5.11	21205-008-11		8" FLANGE TO PIPE	AUG	-	-	-	-	-	-	-
2	1205			OWN	-	-	-	-	-	-	-
				PRE	-	-	-	-	-	-	-
C-F-1	V2 21205-008-12		ISI-21205-008	ISI	-	-	-	-	-	-	-
C5.11	21205-008-12		8" PIPE TO ELBOW	AUG	-	-	-	-	-	-	-

Southern Nuclear Operating Company
3rd Interval
VOGTLE-2 ISI PLAN, VERSION 3.0

Category, Item No., Class	Summary No./ComplID/System	Scope / Method / Procedure	Dwg/ISO No. Comp. Desc. Code Case		Period 1		Period 2		Period 3	
					2VR13	2VR14	2VR14A	2VR15	2VR16	2VR17
2	1205			OWN PRE	-	-	-	-	-	-
C-F-1 C5.11 2	V2 21205-008-13 21205-008-13 1205		ISI-21205-008 8" ELBOW TO PIPE	ISI AUG OWN PRE	-	-	-	-	-	-
C-F-1 C5.11 2	V2 21205-008-14 21205-008-14 1205		ISI-21205-008 8" PIPE TO ELBOW	ISI AUG OWN PRE	-	-	-	-	-	-
C-F-1 C5.11 2	V2 21205-008-15 21205-008-15 1205		ISI-21205-008 8" ELBOW TO PIPE	ISI AUG OWN PRE	-	-	-	-	-	-
C-F-1 C5.11 2	V2 21205-008-16 21205-008-16 1205		ISI-21205-008 8" PIPE TO TEE	ISI AUG OWN PRE	-	-	-	-	-	-
C-F-1 C5.11 2	V2 21205-008-17 21205-008-17 1205	ISI/UT/NMP-ES-024-501 ISI/UT/NMP-ES-024-501	ISI-21205-008 8" TEE TO PIPE	ISI AUG OWN PRE	c	-	-	-	-	-
C-F-1 C5.11 2	V2 21205-008-19 21205-008-19 1205		ISI-21205-008 8" PIPE TO FLANGE	ISI AUG OWN PRE	-	-	-	-	-	-
C-F-1 C5.11 2	V2 21205-008-2 21205-008-2 1205		ISI-21205-008 14" PIPE TO REDUCER	ISI AUG OWN PRE	-	-	-	-	-	-
C-F-1 C5.11 2	V2 21205-008-20 21205-008-20 1205		ISI-21205-008 8" FLANGE TO PIPE	ISI AUG OWN PRE	-	-	-	-	-	-
C-F-1 C5.11 2	V2 21205-008-21 21205-008-21 1205	ISI/UT/	ISI-21205-008 8" PIPE TO ELBOW (AI 87-0131)	ISI AUG OWN PRE	-	-	s	-	-	-
C-F-1 C5.11	V2 21205-008-22 21205-008-22		ISI-21205-008 8" ELBOW TO PIPE	ISI AUG	-	-	-	-	-	-

Southern Nuclear Operating Company
3rd Interval
VOGTLE-2 ISI PLAN, VERSION 3.0

Category, Item No., Class	Summary No./ComplID/System	Scope / Method / Procedure	Dwg/ISO No. Comp. Desc. Code Case		Period 1		Period 2			Period 3	
					2VR13	2VR14	2VR14A	2VR15	2VR16	2VR17	2VR18
2	1205			OWN	-	-	-	-	-	-	-
				PRE	-	-	-	-	-	-	-
C-F-1	V2 21205-008-23		ISI-21205-008	ISI	-	-	-	-	-	-	-
C5.11	21205-008-23		8" PIPE TO TEE	AUG	-	-	-	-	-	-	-
2	1205			OWN	-	-	-	-	-	-	-
				PRE	-	-	-	-	-	-	-
C-F-1	V2 21205-008-24		ISI-21205-008	ISI	-	-	-	-	-	-	-
C5.11	21205-008-24		8" TEE TO PIPE	AUG	-	-	-	-	-	-	-
2	1205			OWN	-	-	-	-	-	-	-
				PRE	-	-	-	-	-	-	-
C-F-1	V2 21205-008-27		ISI-21205-008	ISI	-	-	-	-	-	-	-
C5.11	21205-008-27		8" PIPE TO PIPE	AUG	-	-	-	-	-	-	-
2	1205			OWN	-	-	-	-	-	-	-
				PRE	-	-	-	-	-	-	-
C-F-1	V2 21205-008-28		ISI-21205-008	ISI	-	-	-	-	-	-	-
C5.11	21205-008-28		8" PIPE TO PIPE	AUG	-	-	-	-	-	-	-
2	1205			OWN	-	-	-	-	-	-	-
				PRE	-	-	-	-	-	-	-
C-F-1	V2 21205-008-29		ISI-21205-008	ISI	-	-	-	-	-	-	-
C5.11	21205-008-29		8" PIPE TO PIPE	AUG	-	-	-	-	-	-	-
2	1205			OWN	-	-	-	-	-	-	-
				PRE	-	-	-	-	-	-	-
C-F-1	V2 21205-008-3		ISI-21205-008	ISI	-	-	-	-	-	-	-
C5.11	21205-008-3		8" REDUCER TO PIPE	AUG	-	-	-	-	-	-	-
2	1205			OWN	-	-	-	-	-	-	-
				PRE	-	-	-	-	-	-	-
C-F-1	V2 21205-008-30		ISI-21205-008	ISI	-	-	-	-	-	-	-
C5.11	21205-008-30		8" PIPE TO ELBOW	AUG	-	-	-	-	-	-	-
2	1205			OWN	-	-	-	-	-	-	-
				PRE	-	-	-	-	-	-	-
C-F-1	V2 21205-008-31		ISI-21205-008	ISI	-	-	-	-	-	-	-
C5.11	21205-008-31		8" ELBOW TO PIPE	AUG	-	-	-	-	-	-	-
2	1205			OWN	-	-	-	-	-	-	-
				PRE	-	-	-	-	-	-	-
C-F-1	V2 21205-008-32		ISI-21205-008	ISI	-	-	-	-	-	-	-
C5.11	21205-008-32		8" PIPE TO PIPE	AUG	-	-	-	-	-	-	-
2	1205			OWN	-	-	-	-	-	-	-
				PRE	-	-	-	-	-	-	-
C-F-1	V2 21205-008-33		ISI-21205-008	ISI	-	-	-	-	-	-	-
C5.11	21205-008-33		8" PIPE TO PIPE	AUG	-	-	-	-	-	-	-

Southern Nuclear Operating Company
3rd Interval
VOGTLE-2 ISI PLAN, VERSION 3.0

Category, Item No., Class	Summary No./ComplID/System	Scope / Method / Procedure	Dwg/ISO No. Comp. Desc. Code Case		Period 1		Period 2			Period 3	
					2VR13	2VR14	2VR14A	2VR15	2VR16	2VR17	2VR18
2	1205			OWN	-	-	-	-	-	-	-
				PRE	-	-	-	-	-	-	-
C-F-1	V2 21205-008-34		ISI-21205-008	ISI	-	-	-	-	-	-	-
C5.11	21205-008-34		8" PIPE TO PIPE	AUG	-	-	-	-	-	-	-
2	1205			OWN	-	-	-	-	-	-	-
				PRE	-	-	-	-	-	-	-
C-F-1	V2 21205-008-36		ISI-21205-008	ISI	-	-	-	-	-	-	-
C5.11	21205-008-36		8" PIPE TO ELBOW	AUG	-	-	-	-	-	-	-
2	1205			OWN	-	-	-	-	-	-	-
				PRE	-	-	-	-	-	-	-
C-F-1	V2 21205-008-37		ISI-21205-008	ISI	-	-	-	-	-	-	-
C5.11	21205-008-37		8" ELBOW TO PIPE	AUG	-	-	-	-	-	-	-
2	1205			OWN	-	-	-	-	-	-	-
				PRE	-	-	-	-	-	-	-
C-F-1	V2 21205-008-38		ISI-21205-008	ISI	-	-	-	-	-	-	-
C5.11	21205-008-38		8" PIPE TO ELBOW	AUG	-	-	-	-	-	-	-
2	1205			OWN	-	-	-	-	-	-	-
				PRE	-	-	-	-	-	-	-
C-F-1	V2 21205-008-39		ISI-21205-008	ISI	-	-	-	-	-	-	-
C5.11	21205-008-39		8" ELBOW TO PIPE	AUG	-	-	-	-	-	-	-
2	1205			OWN	-	-	-	-	-	-	-
				PRE	-	-	-	-	-	-	-
C-F-1	V2 21205-008-4		ISI-21205-008	ISI	-	-	-	-	-	-	-
C5.11	21205-008-4		8" PIPE TO ELBOW	AUG	-	-	-	-	-	-	-
2	1205			OWN	-	-	-	-	-	-	-
				PRE	-	-	-	-	-	-	-
C-F-1	V2 21205-008-40		ISI-21205-008	ISI	-	-	-	-	-	-	-
C5.11	21205-008-40		8" PIPE TO PIPE	AUG	-	-	-	-	-	-	-
2	1205			OWN	-	-	-	-	-	-	-
				PRE	-	-	-	-	-	-	-
C-F-1	V2 21205-008-40 A		ISI-21205-008	ISI	-	-	-	-	-	-	-
C5.11	21205-008-40 A		8" PIPE TO PIPE	AUG	-	-	-	-	-	-	-
2	1205			OWN	-	-	-	-	-	-	-
				PRE	-	-	-	-	-	-	-
C-F-1	V2 21205-008-41		ISI-21205-008	ISI	-	-	-	-	-	-	-
C5.11	21205-008-41		8" PIPE TO ELBOW	AUG	-	-	-	-	-	-	-
2	1205			OWN	-	-	-	-	-	-	-
				PRE	-	-	-	-	-	-	-
C-F-1	V2 21205-008-42		ISI-21205-008	ISI	-	-	-	-	-	-	-
C5.11	21205-008-42		8" ELBOW TO PIPE	AUG	-	-	-	-	-	-	-

Southern Nuclear Operating Company
3rd Interval
VOGTLE-2 ISI PLAN, VERSION 3.0

Category, Item No., Class	Summary No./CompID/System	Scope / Method / Procedure	Dwg/ISO No. Comp. Desc. Code Case		Period 1		Period 2			Period 3	
					2VR13	2VR14	2VR14A	2VR15	2VR16	2VR17	2VR18
2	1205			OWN PRE	-	-	-	-	-	-	-
C-F-1 C5.11 2	V2 21205-008-43 21205-008-43 1205		ISI-21205-008 8" PIPE TO ELBOW	ISI AUG OWN PRE	-	-	-	-	-	-	-
C-F-1 C5.11 2	V2 21205-008-44 21205-008-44 1205		ISI-21205-008 8" ELBOW TO PIPE	ISI AUG OWN PRE	-	-	-	-	-	-	-
C-F-1 C5.11 2	V2 21205-008-45 21205-008-45 1205		ISI-21205-008 8" PIPE TO ELBOW	ISI AUG OWN PRE	-	-	-	-	-	-	-
C-F-1 C5.11 2	V2 21205-008-46 21205-008-46 1205		ISI-21205-008 8" ELBOW TO PIPE	ISI AUG OWN PRE	-	-	-	-	-	-	-
C-F-1 C5.11 2	V2 21205-008-46 A 21205-008-46 A 1205		ISI-21205-008 8" PIPE TO PIPE	ISI AUG OWN PRE	-	-	-	-	-	-	-
C-F-1 C5.11 2	V2 21205-008-49 21205-008-49 1205		ISI-21205-008 8" PIPE TO PIPE	ISI AUG OWN PRE	-	-	-	-	-	-	-
C-F-1 C5.11 2	V2 21205-008-5 21205-008-5 1205		ISI-21205-008 8" ELBOW TO PIPE	ISI AUG OWN PRE	-	-	-	-	-	-	-
C-F-1 C5.11 2	V2 21205-008-50 21205-008-50 1205	ISI/UT/	ISI-21205-008 8" PIPE TO ELBOW (AI 87-0131)	ISI AUG OWN PRE	-	-	-	-	-	s	-
C-F-1 C5.11 2	V2 21205-008-51 21205-008-51 1205		ISI-21205-008 8" ELBOW TO PIPE (AI 87-0131)	ISI AUG OWN PRE	-	-	-	-	-	-	-
C-F-1 C5.11	V2 21205-008-52 21205-008-52		ISI-21205-008 8" PIPE TO ELBOW	ISI AUG	-	-	-	-	-	-	-

Southern Nuclear Operating Company
3rd Interval
VOGTLE-2 ISI PLAN, VERSION 3.0

Category, Item No., Class	Summary No./CompID/System	Scope / Method / Procedure	Dwg/ISO No. Comp. Desc. Code Case		Period 1		Period 2		Period 3	
					2VR13	2VR14	2VR14A	2VR15	2VR16	2VR17
2	1205			OWN PRE	-	-	-	-	-	-
C-F-1 C5.11 2	V2 21205-008-53 21205-008-53 1205		ISI-21205-008 8" ELBOW TO PIPE	ISI AUG OWN PRE	-	-	-	-	-	-
C-F-1 C5.11 2	V2 21205-008-54 21205-008-54 1205		ISI-21205-008 8" PIPE TO PIPE	ISI AUG OWN PRE	-	-	-	-	-	-
C-F-1 C5.11 2	V2 21205-008-56 21205-008-56 1205		ISI-21205-008 8" PIPE TO PIPE	ISI AUG OWN PRE	-	-	-	-	-	-
C-F-1 C5.11 2	V2 21205-008-57 21205-008-57 1205		ISI-21205-008 8" PIPE TO ELBOW	ISI AUG OWN PRE	-	-	-	-	-	-
C-F-1 C5.11 2	V2 21205-008-58 21205-008-58 1205		ISI-21205-008 8" ELBOW TO PIPE	ISI AUG OWN PRE	-	-	-	-	-	-
C-F-1 C5.11 2	V2 21205-008-59 21205-008-59 1205		ISI-21205-008 8" PIPE TO ELBOW	ISI AUG OWN PRE	-	-	-	-	-	-
C-F-1 C5.11 2	V2 21205-008-6 21205-008-6 1205		ISI-21205-008 8" PIPE TO FLANGE	ISI AUG OWN PRE	-	-	-	-	-	-
C-F-1 C5.11 2	V2 21205-008-60 21205-008-60 1205		ISI-21205-008 8" ELBOW TO PIPE	ISI AUG OWN PRE	-	-	-	-	-	-
C-F-1 C5.11 2	V2 21205-008-61 21205-008-61 1205		ISI-21205-008 8" PIPE TO ELBOW	ISI AUG OWN PRE	-	-	-	-	-	-
C-F-1 C5.11	V2 21205-008-62 21205-008-62		ISI-21205-008 8" ELBOW TO PIPE	ISI AUG	-	-	-	-	-	-

Southern Nuclear Operating Company
3rd Interval
VOGTLE-2 ISI PLAN, VERSION 3.0

Category, Item No., Class	Summary No./CompID/System	Scope / Method / Procedure	Dwg/ISO No. Comp. Desc. Code Case		Period 1		Period 2		Period 3	
					2VR13	2VR14	2VR14A	2VR15	2VR16	2VR17
	2 1205			OWN PRE	-	-	-	-	-	-
C-F-1	V2 21205-008-63		ISI-21205-008	ISI	-	-	-	-	-	-
C5.11	21205-008-63		8" PIPE TO VALVE	AUG	-	-	-	-	-	-
2	1205			OWN PRE	-	-	-	-	-	-
C-F-1	V2 21205-008-64		ISI-21205-008	ISI	-	-	-	-	-	-
C5.11	21205-008-64		8" TEE TO PIPE	AUG	-	-	-	-	-	-
2	1205			OWN PRE	-	-	-	-	-	-
C-F-1	V2 21205-008-65		ISI-21205-008	ISI	-	-	-	-	-	-
C5.11	21205-008-65		8" PIPE TO TEE	AUG	-	-	-	-	-	-
2	1205			OWN PRE	-	-	-	-	-	-
C-F-1	V2 21205-008-66		ISI-21205-008	ISI	-	-	-	-	-	-
C5.11	21205-008-66		8" TEE TO PIPE	AUG	-	-	-	-	-	-
2	1205			OWN PRE	-	-	-	-	-	-
C-F-1	V2 21205-008-67		ISI-21205-008	ISI	-	-	-	-	-	-
C5.11	21205-008-67		8" PIPE TO VALVE	AUG	-	-	-	-	-	-
2	1205			OWN PRE	-	-	-	-	-	-
C-F-1	V2 21205-008-68		ISI-21205-008	ISI	-	-	-	-	-	-
C5.11	21205-008-68		8" TEE TO PIPE	AUG	-	-	-	-	-	-
2	1205			OWN PRE	-	-	-	-	-	-
C-F-1	V2 21205-008-69		ISI-21205-008	ISI	-	-	-	-	-	-
C5.11	21205-008-69		8" PIPE TO ELBOW	AUG	-	-	-	-	-	-
2	1205			OWN PRE	-	-	-	-	-	-
C-F-1	V2 21205-008-7		ISI-21205-008	ISI	-	-	-	-	-	-
C5.11	21205-008-7		8" FLANGE TO PIPE	AUG	-	-	-	-	-	-
2	1205			OWN PRE	-	-	-	-	-	-
C-F-1	V2 21205-008-70		ISI-21205-008	ISI	-	-	-	-	-	-
C5.11	21205-008-70		8" ELBOW TO PIPE	AUG	-	-	-	-	-	-
2	1205			OWN PRE	-	-	-	-	-	-
C-F-1	V2 21205-008-71		ISI-21205-008	ISI	-	-	-	-	-	-
C5.11	21205-008-71		8" PIPE TO PIPE	AUG	-	-	-	-	-	-

Southern Nuclear Operating Company
3rd Interval
VOGTLE-2 ISI PLAN, VERSION 3.0

Category, Item No., Class	Summary No./ComplD/System	Scope / Method / Procedure	Dwg/ISO No. Comp. Desc. Code Case		Period 1		Period 2			Period 3	
					2VR13	2VR14	2VR14A	2VR15	2VR16	2VR17	2VR18
	1205			OWN	-	-	-	-	-	-	-
				PRE	-	-	-	-	-	-	-
C-F-1	V2 21205-008-72		ISI-21205-008	ISI	-	-	-	-	-	-	-
C5.11	21205-008-72		8" PIPE TO PIPE	AUG	-	-	-	-	-	-	-
2	1205			OWN	-	-	-	-	-	-	-
				PRE	-	-	-	-	-	-	-
C-F-1	V2 21205-008-73		ISI-21205-008	ISI	-	-	-	-	-	-	-
C5.11	21205-008-73		8" PIPE TO ELBOW	AUG	-	-	-	-	-	-	-
2	1205			OWN	-	-	-	-	-	-	-
				PRE	-	-	-	-	-	-	-
C-F-1	V2 21205-008-74		ISI-21205-008	ISI	-	-	-	-	-	-	-
C5.11	21205-008-74		8" ELBOW TO PIPE	AUG	-	-	-	-	-	-	-
2	1205			OWN	-	-	-	-	-	-	-
				PRE	-	-	-	-	-	-	-
C-F-1	V2 21205-008-76		ISI-21205-008	ISI	-	-	-	-	-	-	-
C5.11	21205-008-76		8" PIPE TO ELBOW	AUG	-	-	-	-	-	-	-
2	1205			OWN	-	-	-	-	-	-	-
				PRE	-	-	-	-	-	-	-
C-F-1	V2 21205-008-77		ISI-21205-008	ISI	-	-	-	-	-	-	-
C5.11	21205-008-77		8" ELBOW TO PIPE	AUG	-	-	-	-	-	-	-
2	1205			OWN	-	-	-	-	-	-	-
				PRE	-	-	-	-	-	-	-
C-F-1	V2 21205-008-78		ISI-21205-008	ISI	-	-	-	-	-	-	-
C5.11	21205-008-78		8" PIPE TO ELBOW (AI 87-0131)	AUG	-	-	-	-	-	-	-
2	1205			OWN	-	-	-	-	-	-	-
				PRE	-	-	-	-	-	-	-
C-F-1	V2 21205-008-79		ISI-21205-008	ISI	-	-	-	-	-	-	-
C5.11	21205-008-79		8" ELBOW TO PIPE (AI 87-0131)	AUG	-	-	-	-	-	-	-
2	1205			OWN	-	-	-	-	-	-	-
				PRE	-	-	-	-	-	-	-
C-F-1	V2 21205-008-8		ISI-21205-008	ISI	-	-	-	-	-	-	-
C5.11	21205-008-8		8" PIPE TO ELBOW	AUG	-	-	-	-	-	-	-
2	1205			OWN	-	-	-	-	-	-	-
				PRE	-	-	-	-	-	-	-
C-F-1	V2 21205-008-80		ISI-21205-008	ISI	-	-	-	-	-	-	-
C5.11	21205-008-80		8" PIPE TO VALVE (AI 87-0131)	AUG	-	-	-	-	-	-	-
2	1205			OWN	-	-	-	-	-	-	-
				PRE	-	-	-	-	-	-	-
C-F-1	V2 21205-008-9		ISI-21205-008	ISI	-	-	-	-	-	-	-
C5.11	21205-008-9		8" ELBOW TO PIPE	AUG	-	-	-	-	-	-	-

Southern Nuclear Operating Company
3rd Interval
VOGTLE-2 ISI PLAN, VERSION 3.0

Category, Item No., Class	Summary No./ComplID/System	Scope / Method / Procedure	Dwg/ISO No. Comp. Desc. Code Case	OWN	Period 1		Period 2			Period 3	
					2VR13	2VR14	2VR14A	2VR15	2VR16	2VR17	2VR18
2	1205			OWN	-	-	-	-	-	-	-
				PRE	-	-	-	-	-	-	-
C-F-1	V2 21205-009-1		ISI-21205-009	ISI	-	-	-	-	-	-	-
C5.11	21205-009-1		8" VALVE TO PIPE (AI 87-0131)	AUG	-	-	-	-	-	-	-
2	1205			OWN	-	-	-	-	-	-	-
				PRE	-	-	-	-	-	-	-
C-F-1	V2 21205-009-10		ISI-21205-009	ISI	-	-	-	-	-	-	-
C5.11	21205-009-10		12" PIPE TO TEE	AUG	-	-	-	-	-	-	-
2	1205			OWN	-	-	-	-	-	-	-
				PRE	-	-	-	-	-	-	-
C-F-1	V2 21205-009-11		ISI-21205-009	ISI	-	-	-	-	-	-	-
C5.11	21205-009-11		8" VALVE TO PIPE	AUG	-	-	-	-	-	-	-
2	1205			OWN	-	-	-	-	-	-	-
				PRE	-	-	-	-	-	-	-
C-F-1	V2 21205-009-13		ISI-21205-009	ISI	-	-	-	-	-	-	-
C5.11	21205-009-13		8" PIPE TO ELBOW	AUG	-	-	-	-	-	-	-
2	1205			OWN	-	-	-	-	-	-	-
				PRE	-	-	-	-	-	-	-
C-F-1	V2 21205-009-14		ISI-21205-009	ISI	-	-	-	-	-	-	-
C5.11	21205-009-14		8" ELBOW TO PIPE	AUG	-	-	-	-	-	-	-
2	1205			OWN	-	-	-	-	-	-	-
				PRE	-	-	-	-	-	-	-
C-F-1	V2 21205-009-16		ISI-21205-009	ISI	-	-	-	-	-	-	-
C5.11	21205-009-16		8" PIPE TO REDUCER	AUG	-	-	-	-	-	-	-
2	1205			OWN	-	-	-	-	-	-	-
				PRE	-	-	-	-	-	-	-
C-F-1	V2 21205-009-17		ISI-21205-009	ISI	-	-	-	-	-	-	-
C5.11	21205-009-17		12" REDUCER TO PIPE	AUG	-	-	-	-	-	-	-
2	1205			OWN	-	-	-	-	-	-	-
				PRE	-	-	-	-	-	-	-
C-F-1	V2 21205-009-18		ISI-21205-009	ISI	-	-	-	-	-	-	-
C5.11	21205-009-18		12" PIPE TO TEE	AUG	-	-	-	-	-	-	-
2	1205			OWN	-	-	-	-	-	-	-
				PRE	-	-	-	-	-	-	-
C-F-1	V2 21205-009-19	ISI/UT/	ISI-21205-009	ISI	-	-	-	-	-	-	-
C5.11	21205-009-19		8" TEE TO PIPE (AI 87-0131)	AUG	-	-	-	-	-	-	-
2	1205			OWN	-	-	-	-	-	-	-
				PRE	-	-	-	-	-	-	-
C-F-1	V2 21205-009-2		ISI-21205-009	ISI	-	-	-	-	-	-	-
C5.11	21205-009-2		8" PIPE TO TEE	AUG	-	-	-	-	-	-	-

Southern Nuclear Operating Company
3rd Interval
VOGTLE-2 ISI PLAN, VERSION 3.0

Category, Item No., Class	Summary No./CompID/System	Scope / Method / Procedure	Dwg/ISO No. Comp. Desc. Code Case		Period 1		Period 2			Period 3	
					2VR13	2VR14	2VR14A	2VR15	2VR16	2VR17	2VR18
2	1205			OWN	-	-	-	-	-	-	-
				PRE	-	-	-	-	-	-	-
C-F-1	V2 21205-009-20		ISI-21205-009	ISI	-	-	-	-	-	-	-
C5.11	21205-009-20		8" PIPE TO VALVE	AUG	-	-	-	-	-	-	-
2	1205			OWN	-	-	-	-	-	-	-
				PRE	-	-	-	-	-	-	-
C-F-1	V2 21205-009-21		ISI-21205-009	ISI	-	-	-	-	-	-	-
C5.11	21205-009-21		8" VALVE TO PIPE	AUG	-	-	-	-	-	-	-
2	1205			OWN	-	-	-	-	-	-	-
				PRE	-	-	-	-	-	-	-
C-F-1	V2 21205-009-22		ISI-21205-009	ISI	-	-	-	-	-	-	-
C5.11	21205-009-22		8" PIPE TO ELBOW	AUG	-	-	-	-	-	-	-
2	1205			OWN	-	-	-	-	-	-	-
				PRE	-	-	-	-	-	-	-
C-F-1	V2 21205-009-23		ISI-21205-009	ISI	-	-	-	-	-	-	-
C5.11	21205-009-23		8" ELBOW TO PIPE	AUG	-	-	-	-	-	-	-
2	1205			OWN	-	-	-	-	-	-	-
				PRE	-	-	-	-	-	-	-
C-F-1	V2 21205-009-24		ISI-21205-009	ISI	-	-	-	-	-	-	-
C5.11	21205-009-24		8" PIPE TO VALVE	AUG	-	-	-	-	-	-	-
2	1205			OWN	-	-	-	-	-	-	-
				PRE	-	-	-	-	-	-	-
C-F-1	V2 21205-009-3		ISI-21205-009	ISI	-	-	-	-	-	-	-
C5.11	21205-009-3		8" TEE TO PIPE	AUG	-	-	-	-	-	-	-
2	1205			OWN	-	-	-	-	-	-	-
				PRE	-	-	-	-	-	-	-
C-F-1	V2 21205-009-4		ISI-21205-009	ISI	-	-	-	-	-	-	-
C5.11	21205-009-4		8" PIPE TO PIPE	AUG	-	-	-	-	-	-	-
2	1205			OWN	-	-	-	-	-	-	-
				PRE	-	-	-	-	-	-	-
C-F-1	V2 21205-009-6		ISI-21205-009	ISI	-	-	-	-	-	-	-
C5.11	21205-009-6		8" PIPE TO ELBOW	AUG	-	-	-	-	-	-	-
2	1205			OWN	-	-	-	-	-	-	-
				PRE	-	-	-	-	-	-	-
C-F-1	V2 21205-009-7		ISI-21205-009	ISI	-	-	-	-	-	-	-
C5.11	21205-009-7		8" ELBOW TO PIPE	AUG	-	-	-	-	-	-	-
2	1205			OWN	-	-	-	-	-	-	-
				PRE	-	-	-	-	-	-	-
C-F-1	V2 21205-009-8		ISI-21205-009	ISI	-	-	-	-	-	-	-
C5.11	21205-009-8		8" PIPE TO REDUCER	AUG	-	-	-	-	-	-	-

Southern Nuclear Operating Company
3rd Interval
VOGTLE-2 ISI PLAN, VERSION 3.0

Category, Item No., Class	Summary No./ComplD/System	Scope / Method / Procedure	Dwg/ISO No. Comp. Desc. Code Case		Period 1		Period 2			Period 3	
					2VR13	2VR14	2VR14A	2VR15	2VR16	2VR17	2VR18
2	1205			OWN	-	-	-	-	-	-	-
				PRE	-	-	-	-	-	-	-
C-F-1	V2 21205-009-9		ISI-21205-009	ISI	-	-	-	-	-	-	-
C5.11	21205-009-9		12" REDUCER TO PIPE	AUG	-	-	-	-	-	-	-
2	1205			OWN	-	-	-	-	-	-	-
				PRE	-	-	-	-	-	-	-
C-F-1	V2 21205-010-1		ISI-21205-010	ISI	-	-	-	-	-	-	-
C5.11	21205-010-1		12" TEE TO PIPE	AUG	-	-	-	-	-	-	-
2	1205			OWN	-	-	-	-	-	-	-
				PRE	-	-	-	-	-	-	-
C-F-1	V2 21205-010-10		ISI-21205-010	ISI	-	-	-	-	-	-	-
C5.11	21205-010-10		12" PIPE TO PIPE	AUG	-	-	-	-	-	-	-
2	1205			OWN	-	-	-	-	-	-	-
				PRE	-	-	-	-	-	-	-
C-F-1	V2 21205-010-11		ISI-21205-010	ISI	-	-	-	-	-	-	-
C5.11	21205-010-11		12" PIPE TO PIPE	AUG	-	-	-	-	-	-	-
2	1205			OWN	-	-	-	-	-	-	-
				PRE	-	-	-	-	-	-	-
C-F-1	V2 21205-010-12		ISI-21205-010	ISI	-	-	-	-	-	-	-
C5.11	21205-010-12		12" PIPE TO ELBOW (AI 87-0131)	AUG	-	-	-	-	-	-	-
2	1205			OWN	-	-	-	-	-	-	-
				PRE	-	-	-	-	-	-	-
C-F-1	V2 21205-010-13		ISI-21205-010	ISI	-	-	-	-	-	-	-
C5.11	21205-010-13		12" ELBOW TO PIPE (AI 87-0131)	AUG	-	-	-	-	-	-	-
2	1205			OWN	-	-	-	-	-	-	-
				PRE	-	-	-	-	-	-	-
C-F-1	V2 21205-010-14		ISI-21205-010	ISI	-	-	-	-	-	-	-
C5.11	21205-010-14		12" PIPE TO ELBOW	AUG	-	-	-	-	-	-	-
2	1205			OWN	-	-	-	-	-	-	-
				PRE	-	-	-	-	-	-	-
C-F-1	V2 21205-010-15		ISI-21205-010	ISI	-	-	-	-	-	-	-
C5.11	21205-010-15		12" ELBOW TO PIPE	AUG	-	-	-	-	-	-	-
2	1205			OWN	-	-	-	-	-	-	-
				PRE	-	-	-	-	-	-	-
C-F-1	V2 21205-010-16		ISI-21205-010	ISI	-	-	-	-	-	-	-
C5.11	21205-010-16		12" PIPE TO PIPE	AUG	-	-	-	-	-	-	-
2	1205			OWN	-	-	-	-	-	-	-
				PRE	-	-	-	-	-	-	-
C-F-1	V2 21205-010-17		ISI-21205-010	ISI	-	-	-	-	-	-	-
C5.11	21205-010-17		12" PIPE TO PIPE	AUG	-	-	-	-	-	-	-

Southern Nuclear Operating Company
3rd Interval
VOGTLE-2 ISI PLAN, VERSION 3.0

Category, Item No., Class	Summary No./ComplID/System	Scope / Method / Procedure	Dwg/ISO No. Comp. Desc. Code Case		Period 1		Period 2		Period 3	
					2VR13	2VR14	2VR14A	2VR15	2VR16	2VR17
	2 1205			OWN	-	-	-	-	-	-
				PRE	-	-	-	-	-	-
C-F-1	V2 21205-010-19		ISI-21205-010	ISI	-	-	-	-	-	-
C5.11	21205-010-19		12" PIPE TO ELBOW (AI 87-0131)	AUG	-	-	-	-	-	-
2	1205			OWN	-	-	-	-	-	-
				PRE	-	-	-	-	-	-
C-F-1	V2 21205-010-20		ISI-21205-010	ISI	-	-	-	-	-	-
C5.11	21205-010-20		12" ELBOW TO PIPE	AUG	-	-	-	-	-	-
2	1205			OWN	-	-	-	-	-	-
				PRE	-	-	-	-	-	-
C-F-1	V2 21205-010-21		ISI-21205-010	ISI	-	-	-	-	-	-
C5.11	21205-010-21		12" PIPE TO ELBOW	AUG	-	-	-	-	-	-
2	1205			OWN	-	-	-	-	-	-
				PRE	-	-	-	-	-	-
C-F-1	V2 21205-010-22		ISI-21205-010	ISI	-	-	-	-	-	-
C5.11	21205-010-22		12" ELBOW TO PIPE	AUG	-	-	-	-	-	-
2	1205			OWN	-	-	-	-	-	-
				PRE	-	-	-	-	-	-
C-F-1	V2 21205-010-23		ISI-21205-010	ISI	-	-	-	-	-	-
C5.11	21205-010-23		12" PIPE TO ELBOW	AUG	-	-	-	-	-	-
2	1205			OWN	-	-	-	-	-	-
				PRE	-	-	-	-	-	-
C-F-1	V2 21205-010-24		ISI-21205-010	ISI	-	-	-	-	-	-
C5.11	21205-010-24		12" ELBOW TO PIPE	AUG	-	-	-	-	-	-
2	1205			OWN	-	-	-	-	-	-
				PRE	-	-	-	-	-	-
C-F-1	V2 21205-010-26		ISI-21205-010	ISI	-	-	-	-	-	-
C5.11	21205-010-26		12" PIPE TO PIPE	AUG	-	-	-	-	-	-
2	1205			OWN	-	-	-	-	-	-
				PRE	-	-	-	-	-	-
C-F-1	V2 21205-010-27		ISI-21205-010	ISI	-	-	-	-	-	-
C5.11	21205-010-27		12" PIPE TO ELBOW	AUG	-	-	-	-	-	-
2	1205			OWN	-	-	-	-	-	-
				PRE	-	-	-	-	-	-
C-F-1	V2 21205-010-28		ISI-21205-010	ISI	-	-	-	-	-	-
C5.11	21205-010-28		12" ELBOW TO PIPE	AUG	-	-	-	-	-	-
2	1205			OWN	-	-	-	-	-	-
				PRE	-	-	-	-	-	-
C-F-1	V2 21205-010-29		ISI-21205-010	ISI	-	-	-	-	-	-
C5.11	21205-010-29		12" PIPE TO FLANGE	AUG	-	-	-	-	-	-

Southern Nuclear Operating Company
3rd Interval
VOGTLE-2 ISI PLAN, VERSION 3.0

Category, Item No., Class	Summary No./ComplID/System	Scope / Method / Procedure	Dwg/ISO No. Comp. Desc. Code Case		Period 1		Period 2			Period 3	
					2VR13	2VR14	2VR14A	2VR15	2VR16	2VR17	2VR18
2	1205			OWN	-	-	-	-	-	-	-
				PRE	-	-	-	-	-	-	-
C-F-1	V2 21205-010-3		ISI-21205-010	ISI	-	-	-	-	-	-	-
C5.11	21205-010-3		12" PIPE TO ELBOW	AUG	-	-	-	-	-	-	-
2	1205			OWN	-	-	-	-	-	-	-
				PRE	-	-	-	-	-	-	-
C-F-1	V2 21205-010-30		ISI-21205-010	ISI	-	-	-	-	-	-	-
C5.11	21205-010-30		12" FLANGE TO PIPE	AUG	-	-	-	-	-	-	-
2	1205			OWN	-	-	-	-	-	-	-
				PRE	-	-	-	-	-	-	-
C-F-1	V2 21205-010-31		ISI-21205-010	ISI	-	-	-	-	-	-	-
C5.11	21205-010-31		12" PIPE TO ELBOW	AUG	-	-	-	-	-	-	-
2	1205			OWN	-	-	-	-	-	-	-
				PRE	-	-	-	-	-	-	-
C-F-1	V2 21205-010-32		ISI-21205-010	ISI	-	-	-	-	-	-	-
C5.11	21205-010-32		12" ELBOW TO PIPE	AUG	-	-	-	-	-	-	-
2	1205			OWN	-	-	-	-	-	-	-
				PRE	-	-	-	-	-	-	-
C-F-1	V2 21205-010-33		ISI-21205-010	ISI	-	-	-	-	-	-	-
C5.11	21205-010-33		12" PIPE TO VALVE	AUG	-	-	-	-	-	-	-
2	1205			OWN	-	-	-	-	-	-	-
				PRE	-	-	-	-	-	-	-
C-F-1	V2 21205-010-4		ISI-21205-010	ISI	-	-	-	-	-	-	-
C5.11	21205-010-4		12" ELBOW TO PIPE	AUG	-	-	-	-	-	-	-
2	1205			OWN	-	-	-	-	-	-	-
				PRE	-	-	-	-	-	-	-
C-F-1	V2 21205-010-5		ISI-21205-010	ISI	-	-	-	-	-	-	-
C5.11	21205-010-5		12" PIPE TO PIPE	AUG	-	-	-	-	-	-	-
2	1205			OWN	-	-	-	-	-	-	-
				PRE	-	-	-	-	-	-	-
C-F-1	V2 21205-010-7		ISI-21205-010	ISI	-	-	-	-	-	-	-
C5.11	21205-010-7		12" PIPE TO PIPE	AUG	-	-	-	-	-	-	-
2	1205			OWN	-	-	-	-	-	-	-
				PRE	-	-	-	-	-	-	-
C-F-1	V2 21205-010-8		ISI-21205-010	ISI	-	-	-	-	-	-	-
C5.11	21205-010-8		12" PIPE TO PIPE	AUG	-	-	-	-	-	-	-
2	1205			OWN	-	-	-	-	-	-	-
				PRE	-	-	-	-	-	-	-
C-F-1	V2 21205-027-1		ISI-21205-027	ISI	-	-	-	-	-	-	-
C5.11	21205-027-1		14" PIPE TO VALVE	AUG	-	-	-	-	-	-	-

Southern Nuclear Operating Company
3rd Interval
VOGTLE-2 ISI PLAN, VERSION 3.0

Category, Item No., Class	Summary No./ComplID/System	Scope / Method / Procedure	Dwg/ISO No. Comp. Desc. Code Case		Period 1		Period 2			Period 3	
					2VRI3	2VRI4	2VRI4A	2VRI5	2VRI6	2VRI7	2VRI8
2	1205			OWN	-	-	-	-	-	-	-
				PRE	-	-	-	-	-	-	-
C-F-1	V2 21205-027-11		ISI-21205-027	ISI	-	-	-	-	-	-	-
C5.11	21205-027-11		14" PIPE TO VALVE	AUG	-	-	-	-	-	-	-
2	1205			OWN	-	-	-	-	-	-	-
				PRE	-	-	-	-	-	-	-
C-F-1	V2 21205-027-12		ISI-21205-027	ISI	-	-	-	-	-	-	-
C5.11	21205-027-12		14" VALVE TO PIPE	AUG	-	-	-	-	-	-	-
2	1205			OWN	-	-	-	-	-	-	-
				PRE	-	-	-	-	-	-	-
C-F-1	V2 21205-027-13		ISI-21205-027	ISI	-	-	-	-	-	-	-
C5.11	21205-027-13		14" PIPE TO ELBOW	AUG	-	-	-	-	-	-	-
2	1205			OWN	-	-	-	-	-	-	-
				PRE	-	-	-	-	-	-	-
C-F-1	V2 21205-027-14		ISI-21205-027	ISI	-	-	-	-	-	-	-
C5.11	21205-027-14		14" ELBOW TO PIPE (AI 87-0131)	AUG	-	-	-	-	-	-	-
2	1205			OWN	-	-	-	-	-	-	-
				PRE	-	-	-	-	-	-	-
C-F-1	V2 21205-027-16		ISI-21205-027	ISI	-	-	-	-	-	-	-
C5.11	21205-027-16		14" PIPE TO ELBOW	AUG	-	-	-	-	-	-	-
2	1205			OWN	-	-	-	-	-	-	-
				PRE	-	-	-	-	-	-	-
C-F-1	V2 21205-027-17		ISI-21205-027	ISI	-	-	-	-	-	-	-
C5.11	21205-027-17		14" ELBOW TO PIPE	AUG	-	-	-	-	-	-	-
2	1205			OWN	-	-	-	-	-	-	-
				PRE	-	-	-	-	-	-	-
C-F-1	V2 21205-027-18		ISI-21205-027	ISI	-	-	-	-	-	-	-
C5.11	21205-027-18		14" PIPE TO TEE	AUG	-	-	-	-	-	-	-
2	1205			OWN	-	-	-	-	-	-	-
				PRE	-	-	-	-	-	-	-
C-F-1	V2 21205-027-2		ISI-21205-027	ISI	-	-	-	-	-	-	-
C5.11	21205-027-2		14" VALVE TO PIPE	AUG	-	-	-	-	-	-	-
2	1205			OWN	-	-	-	-	-	-	-
				PRE	-	-	-	-	-	-	-
C-F-1	V2 21205-027-4		ISI-21205-027	ISI	-	-	-	-	-	-	-
C5.11	21205-027-4		14" PIPE TO ELBOW	AUG	-	-	-	-	-	-	-
2	1205			OWN	-	-	-	-	-	-	-
				PRE	-	-	-	-	-	-	-
C-F-1	V2 21205-027-5		ISI-21205-027	ISI	-	-	-	-	-	-	-
C5.11	21205-027-5		14" ELBOW TO PIPE	AUG	-	-	-	-	-	-	-

Southern Nuclear Operating Company
3rd Interval
VOGTLE-2 ISI PLAN, VERSION 3.0

Category, Item No., Class	Summary No./CompID/System	Scope / Method / Procedure	Dwg/ISO No. Comp. Desc. Code Case		Period 1		Period 2			Period 3	
					2VR13	2VR14	2VR14A	2VR15	2VR16	2VR17	2VR18
	1205			OWN	-	-	-	-	-	-	-
				PRE	-	-	-	-	-	-	-
C-F-1	V2 21205-027-7		ISI-21205-027	ISI	-	-	-	-	-	-	-
C5.11	21205-027-7		14" PIPE TO ELBOW	AUG	-	-	-	-	-	-	-
2	1205			OWN	-	-	-	-	-	-	-
				PRE	-	-	-	-	-	-	-
C-F-1	V2 21205-027-8		ISI-21205-027	ISI	-	-	-	-	-	-	-
C5.11	21205-027-8		14" ELBOW TO PIPE	AUG	-	-	-	-	-	-	-
2	1205			OWN	-	-	-	-	-	-	-
				PRE	-	-	-	-	-	-	-
C-F-1	V2 21205-028-1		ISI-21205-028	ISI	-	-	-	-	-	-	-
C5.11	21205-028-1		14" PIPE TO VALVE	AUG	-	-	-	-	-	-	-
2	1205			OWN	-	-	-	-	-	-	-
				PRE	-	-	-	-	-	-	-
C-F-1	V2 21205-028-2		ISI-21205-028	ISI	-	-	-	-	-	-	-
C5.11	21205-028-2		14" VALVE TO PIPE	AUG	-	-	-	-	-	-	-
2	1205			OWN	-	-	-	-	-	-	-
				PRE	-	-	-	-	-	-	-
C-F-1	V2 21205-028-4		ISI-21205-028	ISI	-	-	-	-	-	-	-
C5.11	21205-028-4		14" PIPE TO ELBOW (AI 87-0131)	AUG	-	-	-	-	-	-	-
2	1205			OWN	-	-	-	-	-	-	-
				PRE	-	-	-	-	-	-	-
C-F-1	V2 21205-028-5		ISI-21205-028	ISI	-	-	-	-	-	-	-
C5.11	21205-028-5		14" ELBOW TO PIPE	AUG	-	-	-	-	-	-	-
2	1205			OWN	-	-	-	-	-	-	-
				PRE	-	-	-	-	-	-	-
C-F-1	V2 21205-028-6		ISI-21205-028	ISI	-	-	-	-	-	-	-
C5.11	21205-028-6		14" PIPE TO PIPE	AUG	-	-	-	-	-	-	-
2	1205			OWN	-	-	-	-	-	-	-
				PRE	-	-	-	-	-	-	-
C-F-1	V2 21205-028-8		ISI-21205-028	ISI	-	-	-	-	-	-	-
C5.11	21205-028-8		14" PIPE TO VALVE	AUG	-	-	-	-	-	-	-
2	1205			OWN	-	-	-	-	-	-	-
				PRE	-	-	-	-	-	-	-
C-F-1	V2 21205-039-1		ISI-21205-039	ISI	-	-	-	-	-	-	-
C5.11	21205-039-1		12" VALVE TO PIPE	AUG	-	-	-	-	-	-	-
2	1205			OWN	-	-	-	-	-	-	-
				PRE	-	-	-	-	-	-	-
C-F-1	V2 21205-039-2		ISI-21205-039	ISI	-	-	-	-	-	-	-
C5.11	21205-039-2		12" PIPE TO VALVE	AUG	-	-	-	-	-	-	-

Southern Nuclear Operating Company
3rd Interval
VOGTLE-2 ISI PLAN, VERSION 3.0

Category, Item No., Class	Summary No./Compld/System 1205	Scope / Method / Procedure	Dwg/ISO No. Comp. Desc. Code Case		Period 1		Period 2			Period 3	
					2VR13	2VR14	2VR14A	2VR15	2VR16	2VR17	2VR18
				OWN	-	-	-	-	-	-	-
				PRE	-	-	-	-	-	-	-
C-F-1	V2 21205-039-3		ISI-21205-039	ISI	-	-	-	-	-	-	-
C5.11	21205-039-3		12" VALVE TO PIPE	AUG	-	-	-	-	-	-	-
2	1205			OWN	-	-	-	-	-	-	-
				PRE	-	-	-	-	-	-	-
C-F-1	V2 21205-039-4		ISI-21205-039	ISI	-	-	-	-	-	-	-
C5.11	21205-039-4		12" PIPE TO ELBOW	AUG	-	-	-	-	-	-	-
2	1205			OWN	-	-	-	-	-	-	-
				PRE	-	-	-	-	-	-	-
C-F-1	V2 21205-039-5		ISI-21205-039	ISI	-	-	-	-	-	-	-
C5.11	21205-039-5		12" ELBOW TO PIPE	AUG	-	-	-	-	-	-	-
2	1205			OWN	-	-	-	-	-	-	-
				PRE	-	-	-	-	-	-	-
C-F-1	V2 21205-039-6		ISI-21205-039	ISI	-	-	-	-	-	-	-
C5.11	21205-039-6		12" PIPE TO ELBOW	AUG	-	-	-	-	-	-	-
2	1205			OWN	-	-	-	-	-	-	-
				PRE	-	-	-	-	-	-	-
C-F-1	V2 21205-039-7		ISI-21205-039	ISI	-	-	-	-	-	-	-
C5.11	21205-039-7		12" ELBOW TO PIPE	AUG	-	-	-	-	-	-	-
2	1205			OWN	-	-	-	-	-	-	-
				PRE	-	-	-	-	-	-	-
C-F-1	V2 21205-039-8	ISI/UT/	ISI-21205-039	ISI	-	-	-	-	-	s	-
C5.11	21205-039-8		12" PIPE TO TEE (AI 87-0131)	AUG	-	-	-	-	-	-	-
2	1205			OWN	-	-	-	-	-	-	-
				PRE	-	-	-	-	-	-	-
C-F-1	V2 21205-040-1		ISI-21205-040	ISI	-	-	-	-	-	-	-
C5.11	21205-040-1		12" VALVE TO PIPE	AUG	-	-	-	-	-	-	-
2	1205			OWN	-	-	-	-	-	-	-
				PRE	-	-	-	-	-	-	-
C-F-1	V2 21205-040-2		ISI-21205-040	ISI	-	-	-	-	-	-	-
C5.11	21205-040-2		12" PIPE TO VALVE	AUG	-	-	-	-	-	-	-
2	1205			OWN	-	-	-	-	-	-	-
				PRE	-	-	-	-	-	-	-
C-F-1	V2 21205-040-3		ISI-21205-040	ISI	-	-	-	-	-	-	-
C5.11	21205-040-3		12" VALVE TO PIPE	AUG	-	-	-	-	-	-	-
2	1205			OWN	-	-	-	-	-	-	-
				PRE	-	-	-	-	-	-	-
C-F-1	V2 21205-040-4		ISI-21205-040	ISI	-	-	-	-	-	-	-
C5.11	21205-040-4		12" PIPE TO ELBOW	AUG	-	-	-	-	-	-	-

Southern Nuclear Operating Company
3rd Interval
VOGTLE-2 ISI PLAN, VERSION 3.0

Category, Item No., Class	Summary No./ComplD/System	Scope / Method / Procedure	Dwg/ISO No. Comp. Desc. Code Case		Period 1		Period 2			Period 3	
					2VR13	2VR14	2VR14A	2VR15	2VR16	2VR17	2VR18
2	1205			OWN	-	-	-	-	-	-	-
				PRE	-	-	-	-	-	-	-
C-F-1	V2 21205-040-5		ISI-21205-040	ISI	-	-	-	-	-	-	-
C5.11	21205-040-5		12" ELBOW TO PIPE	AUG	-	-	-	-	-	-	-
2	1205			OWN	-	-	-	-	-	-	-
				PRE	-	-	-	-	-	-	-
C-F-1	V2 21205-040-6		ISI-21205-040	ISI	-	-	-	-	-	-	-
C5.11	21205-040-6		12" PIPE TO ELBOW	AUG	-	-	-	-	-	-	-
2	1205			OWN	-	-	-	-	-	-	-
				PRE	-	-	-	-	-	-	-
C-F-1	V2 21205-040-7		ISI-21205-040	ISI	-	-	-	-	-	-	-
C5.11	21205-040-7		12" ELBOW TO PIPE	AUG	-	-	-	-	-	-	-
2	1205			OWN	-	-	-	-	-	-	-
				PRE	-	-	-	-	-	-	-
C-F-1	V2 21205-040-8		ISI-21205-040	ISI	-	-	-	-	-	-	-
C5.11	21205-040-8		12" PIPE TO TEE	AUG	-	-	-	-	-	-	-
2	1205			OWN	-	-	-	-	-	-	-
				PRE	-	-	-	-	-	-	-
C-F-1	V2 21206-001-1	ISI/UT/	ISI-21206-001	ISI	-	-	-	-	-	s	-
C5.11	21206-001-1		12" PIPE TO REDUCER	AUG	-	-	-	-	-	-	-
2	1206			OWN	-	-	-	-	-	-	-
				PRE	-	-	-	-	-	-	-
C-F-1	V2 21206-001-10		ISI-21206-001	ISI	-	-	-	-	-	-	-
C5.11	21206-001-10		10" VALVE TO REDUCER	AUG	-	-	-	-	-	-	-
2	1206			OWN	-	-	-	-	-	-	-
				PRE	-	-	-	-	-	-	-
C-F-1	V2 21206-001-11	ISI/UT/	ISI-21206-001	ISI	-	-	-	s	-	-	-
C5.11	21206-001-11		12" REDUCER TO ELBOW	AUG	-	-	-	-	-	-	-
2	1206			OWN	-	-	-	-	-	-	-
				PRE	-	-	-	-	-	-	-
C-F-1	V2 21206-001-12	ISI/UT/	ISI-21206-001	ISI	-	-	-	s	-	-	-
C5.11	21206-001-12		12" ELBOW TO PIPE	AUG	-	-	-	-	-	-	-
2	1206			OWN	-	-	-	-	-	-	-
				PRE	-	-	-	-	-	-	-
C-F-1	V2 21206-001-13	ISI/UT/	ISI-21206-001	ISI	-	-	-	s	-	-	-
C5.11	21206-001-13		12" PIPE TO ELBOW	AUG	-	-	-	-	-	-	-
2	1206			OWN	-	-	-	-	-	-	-
				PRE	-	-	-	-	-	-	-
C-F-1	V2 21206-001-14	ISI/UT/	ISI-21206-001	ISI	-	-	-	s	-	-	-
C5.11	21206-001-14		12" ELBOW TO PIPE	AUG	-	-	-	-	-	-	-

Southern Nuclear Operating Company
3rd Interval
VOGTLE-2 ISI PLAN, VERSION 3.0

Category, Item No., Class	Summary No./CompID/System	Scope / Method / Procedure	Dwg/ISO No. Comp. Desc. Code Case		Period 1		Period 2			Period 3	
					2VR13	2VR14	2VR14A	2VR15	2VR16	2VR17	2VR18
2	1206			OWN	-	-	-	-	-	-	-
				PRE	-	-	-	-	-	-	-
C-F-1	V2 21206-001-15		ISI-21206-001	ISI	-	-	-	-	-	-	-
C5.11	21206-001-15		12" PIPE TO PIPE	AUG	-	-	-	-	-	-	-
2	1206			OWN	-	-	-	-	-	-	-
				PRE	-	-	-	-	-	-	-
C-F-1	V2 21206-001-17	ISI/UT/	ISI-21206-001	ISI	-	-	-	s	-	-	-
C5.11	21206-001-17		12" PIPE TO ELBOW	AUG	-	-	-	-	-	-	-
2	1206			OWN	-	-	-	-	-	-	-
				PRE	-	-	-	-	-	-	-
C-F-1	V2 21206-001-18	ISI/UT/	ISI-21206-001	ISI	-	-	-	s	-	-	-
C5.11	21206-001-18		12" ELBOW TO PIPE	AUG	-	-	-	-	-	-	-
2	1206			OWN	-	-	-	-	-	-	-
				PRE	-	-	-	-	-	-	-
C-F-1	V2 21206-001-2		ISI-21206-001	ISI	-	-	-	-	-	-	-
C5.11	21206-001-2		10" REDUCER TO VALVE	AUG	-	-	-	-	-	-	-
2	1206			OWN	-	-	-	-	-	-	-
				PRE	-	-	-	-	-	-	-
C-F-1	V2 21206-001-20		ISI-21206-001	ISI	-	-	-	-	-	-	-
C5.11	21206-001-20		12" PIPE TO PIPE	AUG	-	-	-	-	-	-	-
2	1206			OWN	-	-	-	-	-	-	-
				PRE	-	-	-	-	-	-	-
C-F-1	V2 21206-001-21		ISI-21206-001	ISI	-	-	-	-	-	-	-
C5.11	21206-001-21		12" PIPE TO ELBOW	AUG	-	-	-	-	-	-	-
2	1206			OWN	-	-	-	-	-	-	-
				PRE	-	-	-	-	-	-	-
C-F-1	V2 21206-001-22		ISI-21206-001	ISI	-	-	-	-	-	-	-
C5.11	21206-001-22		12" ELBOW TO PIPE	AUG	-	-	-	-	-	-	-
2	1206			OWN	-	-	-	-	-	-	-
				PRE	-	-	-	-	-	-	-
C-F-1	V2 21206-001-25		ISI-21206-001	ISI	-	-	-	-	-	-	-
C5.11	21206-001-25		12" PIPE TO ELBOW	AUG	-	-	-	-	-	-	-
2	1206			OWN	-	-	-	-	-	-	-
				PRE	-	-	-	-	-	-	-
C-F-1	V2 21206-001-26		ISI-21206-001	ISI	-	-	-	-	-	-	-
C5.11	21206-001-26		12" ELBOW TO TEE	AUG	-	-	-	-	-	-	-
2	1206			OWN	-	-	-	-	-	-	-
				PRE	-	-	-	-	-	-	-
C-F-1	V2 21206-001-27		ISI-21206-001	ISI	-	-	-	-	-	-	-
C5.11	21206-001-27		12" TEE TO PIPE	AUG	-	-	-	-	-	-	-

Southern Nuclear Operating Company
3rd Interval
VOGTLE-2 ISI PLAN, VERSION 3.0

Category, Item No., Class	Summary No./Compld/System 1206	Scope / Method / Procedure	Dwg/ISO No. Comp. Desc. Code Case		Period 1		Period 2			Period 3	
					2VR13	2VR14	2VR14A	2VR15	2VR16	2VR17	2VR18
				OWN	-	-	-	-	-	-	-
				PRE	-	-	-	-	-	-	-
C-F-1	V2 21206-001-29	ISI/UT/NMP-ES-024-501	ISI-21206-001	ISI	-	s	-	-	-	-	-
C5.11	21206-001-29		12" PIPE TO ELBOW (AI 87-0131)	AUG	-	-	-	-	-	-	-
2	1206			OWN	-	-	-	-	-	-	-
				PRE	-	-	-	-	-	-	-
C-F-1	V2 21206-001-3		ISI-21206-001	ISI	-	-	-	-	-	-	-
C5.11	21206-001-3		10" VALVE TO REDUCER	AUG	-	-	-	-	-	-	-
2	1206			OWN	-	-	-	-	-	-	-
				PRE	-	-	-	-	-	-	-
C-F-1	V2 21206-001-30		ISI-21206-001	ISI	-	-	-	-	-	-	-
C5.11	21206-001-30		12" ELBOW TO PIPE	AUG	-	-	-	-	-	-	-
2	1206			OWN	-	-	-	-	-	-	-
				PRE	-	-	-	-	-	-	-
C-F-1	V2 21206-001-31		ISI-21206-001	ISI	-	-	-	-	-	-	-
C5.11	21206-001-31		12" PIPE TO FLANGE	AUG	-	-	-	-	-	-	-
2	1206			OWN	-	-	-	-	-	-	-
				PRE	-	-	-	-	-	-	-
C-F-1	V2 21206-001-32		ISI-21206-001	ISI	-	-	-	-	-	-	-
C5.11	21206-001-32		12" FLANGE TO PIPE	AUG	-	-	-	-	-	-	-
2	1206			OWN	-	-	-	-	-	-	-
				PRE	-	-	-	-	-	-	-
C-F-1	V2 21206-001-33		ISI-21206-001	ISI	-	-	-	-	-	-	-
C5.11	21206-001-33		12" PIPE TO FLANGE	AUG	-	-	-	-	-	-	-
2	1206			OWN	-	-	-	-	-	-	-
				PRE	-	-	-	-	-	-	-
C-F-1	V2 21206-001-34		ISI-21206-001	ISI	-	-	-	-	-	-	-
C5.11	21206-001-34		12" FLANGE TO ELBOW	AUG	-	-	-	-	-	-	-
2	1206			OWN	-	-	-	-	-	-	-
				PRE	-	-	-	-	-	-	-
C-F-1	V2 21206-001-35		ISI-21206-001	ISI	-	-	-	-	-	-	-
C5.11	21206-001-35		12" ELBOW TO PIPE	AUG	-	-	-	-	-	-	-
2	1206			OWN	-	-	-	-	-	-	-
				PRE	-	-	-	-	-	-	-
C-F-1	V2 21206-001-36	ISI/UT/NMP-ES-024-501	ISI-21206-001	ISI	-	s	-	-	-	-	-
C5.11	21206-001-36		12" PIPE TO REDUCER (AI 87-0131)	AUG	-	-	-	-	-	-	-
2	1206			OWN	-	-	-	-	-	-	-
				PRE	-	-	-	-	-	-	-
C-F-1	V2 21206-001-37		ISI-21206-001	ISI	-	-	-	-	-	-	-
C5.11	21206-001-37		10" REDUCER TO FLANGE	AUG	-	-	-	-	-	-	-

Southern Nuclear Operating Company
3rd Interval
VOGTLE-2 ISI PLAN, VERSION 3.0

Category, Item No., Class	Summary No./CompID/System	Scope / Method / Procedure	Dwg/ISO No. Comp. Desc. Code Case	OWN PRE	Period 1		Period 2			Period 3	
					2VR13	2VR14	2VR14A	2VR15	2VR16	2VR17	2VR18
2	1206			OWN PRE	-	-	-	-	-	-	-
C-F-1 C5.11 2	V2 21206-001-4 21206-001-4 1206		ISI-21206-001 12" REDUCER TO PIPE	ISI AUG OWN PRE	-	-	-	-	-	-	-
C-F-1 C5.11 2	V2 21206-001-6 21206-001-6 1206		ISI-21206-001 12" PIPE TO ELBOW	ISI AUG OWN PRE	-	-	-	-	-	-	-
C-F-1 C5.11 2	V2 21206-001-7 21206-001-7 1206		ISI-21206-001 12" ELBOW TO PIPE	ISI AUG OWN PRE	-	-	-	-	-	-	-
C-F-1 C5.11 2	V2 21206-001-8 21206-001-8 1206		ISI-21206-001 12" PIPE TO REDUCER	ISI AUG OWN PRE	-	-	-	-	-	-	-
C-F-1 C5.11 2	V2 21206-001-9 21206-001-9 1206		ISI-21206-001 10" REDUCER TO VALVE	ISI AUG OWN PRE	-	-	-	-	-	-	-
C-F-1 C5.11 2	V2 21206-002-1 21206-002-1 1206		ISI-21206-002 12" PIPE TO REDUCER	ISI AUG OWN PRE	-	-	-	-	-	-	-
C-F-1 C5.11 2	V2 21206-002-10 21206-002-10 1206	ISI/UT/	ISI-21206-002 12" PIPE TO ELBOW	ISI AUG OWN PRE	-	-	-	-	-	s	-
C-F-1 C5.11 2	V2 21206-002-11 21206-002-11 1206	ISI/UT/	ISI-21206-002 12" ELBOW TO PIPE	ISI AUG OWN PRE	-	-	-	-	-	s	-
C-F-1 C5.11 2	V2 21206-002-12 21206-002-12 1206		ISI-21206-002 12" PIPE TO ELBOW	ISI AUG OWN PRE	-	-	-	-	-	-	-
C-F-1 C5.11	V2 21206-002-13 21206-002-13		ISI-21206-002 12" ELBOW TO PIPE	ISI AUG	-	-	-	-	-	-	-

Southern Nuclear Operating Company
3rd Interval
VOGTLE-2 ISI PLAN, VERSION 3.0

Category, Item No., Class	Summary No./CompID/System	Scope / Method / Procedure	Dwg/ISO No. Comp. Desc. Code Case		Period 1		Period 2			Period 3	
					2VR13	2VR14	2VR14A	2VR15	2VR16	2VR17	2VR18
2	1206			OWN PRE	-	-	-	-	-	-	-
C-F-1 C5.11 2	V2 21206-002-14 21206-002-14 1206		ISI-21206-002 12" PIPE TO ELBOW	ISI AUG OWN PRE	-	-	-	-	-	-	-
C-F-1 C5.11 2	V2 21206-002-15 21206-002-15 1206		ISI-21206-002 12" ELBOW TO PIPE	ISI AUG OWN PRE	-	-	-	-	-	-	-
C-F-1 C5.11 2	V2 21206-002-16 A 21206-002-16 A 1206		ISI-21206-002 12" PIPE TO PIPE	ISI AUG OWN PRE	-	-	-	-	-	-	-
C-F-1 C5.11 2	V2 21206-002-17 21206-002-17 1206	ISI/UT/	ISI-21206-002 12" PIPE TO ELBOW	ISI AUG OWN PRE	-	-	-	-	-	s	-
C-F-1 C5.11 2	V2 21206-002-18 21206-002-18 1206	ISI/UT/	ISI-21206-002 12" ELBOW TO PIPE	ISI AUG OWN PRE	-	-	-	-	-	s	-
C-F-1 C5.11 2	V2 21206-002-19 21206-002-19 1206	ISI/UT/	ISI-21206-002 12" PIPE TO ELBOW	ISI AUG OWN PRE	-	-	-	-	-	s	-
C-F-1 C5.11 2	V2 21206-002-2 21206-002-2 1206		ISI-21206-002 10" REDUCER TO VALVE	ISI AUG OWN PRE	-	-	-	-	-	-	-
C-F-1 C5.11 2	V2 21206-002-20 21206-002-20 1206	ISI/UT/	ISI-21206-002 12" ELBOW TO PIPE	ISI AUG OWN PRE	-	-	-	-	-	s	-
C-F-1 C5.11 2	V2 21206-002-21 A 21206-002-21 A 1206		ISI-21206-002 12" PIPE TO PIPE	ISI AUG OWN PRE	-	-	-	-	-	-	-
C-F-1 C5.11	V2 21206-002-22 21206-002-22		ISI-21206-002 12" PIPE TO ELBOW	ISI AUG	-	-	-	-	-	-	-

Southern Nuclear Operating Company
3rd Interval
VOGTLE-2 ISI PLAN, VERSION 3.0

Category, Item No., Class	Summary No./CompID/System	Scope / Method / Procedure	Dwg/ISO No. Comp. Desc. Code Case		Period 1		Period 2			Period 3	
					2VR13	2VR14	2VR14A	2VR15	2VR16	2VR17	2VR18
2	1206			OWN PRE	-	-	-	-	-	-	-
C-F-1	V2 21206-002-23		ISI-21206-002	ISI	-	-	-	-	-	-	-
C5.11	21206-002-23		12" ELBOW TO PIPE	AUG	-	-	-	-	-	-	-
2	1206			OWN PRE	-	-	-	-	-	-	-
C-F-1	V2 21206-002-24		ISI-21206-002	ISI	-	-	-	-	-	-	-
C5.11	21206-002-24		12" PIPE TO PIPE	AUG	-	-	-	-	-	-	-
2	1206			OWN PRE	-	-	-	-	-	-	-
C-F-1	V2 21206-002-25		ISI-21206-002	ISI	-	-	-	-	-	-	-
C5.11	21206-002-25		12" PIPE TO ELBOW	AUG	-	-	-	-	-	-	-
2	1206			OWN PRE	-	-	-	-	-	-	-
C-F-1	V2 21206-002-26		ISI-21206-002	ISI	-	-	-	-	-	-	-
C5.11	21206-002-26		12" ELBOW TO PIPE	AUG	-	-	-	-	-	-	-
2	1206			OWN PRE	-	-	-	-	-	-	-
C-F-1	V2 21206-002-27		ISI-21206-002	ISI	-	-	-	-	-	-	-
C5.11	21206-002-27		12" PIPE TO ELBOW	AUG	-	-	-	-	-	-	-
2	1206			OWN PRE	-	-	-	-	-	-	-
C-F-1	V2 21206-002-28		ISI-21206-002	ISI	-	-	-	-	-	-	-
C5.11	21206-002-28		12" ELBOW TO PIPE	AUG	-	-	-	-	-	-	-
2	1206			OWN PRE	-	-	-	-	-	-	-
C-F-1	V2 21206-002-3		ISI-21206-002	ISI	-	-	-	-	-	-	-
C5.11	21206-002-3		10" VALVE TO REDUCER	AUG	-	-	-	-	-	-	-
2	1206			OWN PRE	-	-	-	-	-	-	-
C-F-1	V2 21206-002-30		ISI-21206-002	ISI	-	-	-	-	-	-	-
C5.11	21206-002-30		12" PIPE TO ELBOW	AUG	-	-	-	-	-	-	-
2	1206			OWN PRE	-	-	-	-	-	-	-
C-F-1	V2 21206-002-31		ISI-21206-002	ISI	-	-	-	-	-	-	-
C5.11	21206-002-31		12" ELBOW TO PIPE	AUG	-	-	-	-	-	-	-
2	1206			OWN PRE	-	-	-	-	-	-	-
C-F-1	V2 21206-002-32		ISI-21206-002	ISI	-	-	-	-	-	-	-
C5.11	21206-002-32		12" PIPE TO ELBOW	AUG	-	-	-	-	-	-	-

Southern Nuclear Operating Company
3rd Interval
VOGTLE-2 ISI PLAN, VERSION 3.0

Category, Item No., Class	Summary No./Compld/System	Scope / Method / Procedure	Dwg/ISO No. Comp. Desc. Code Case		Period 1		Period 2		Period 3	
					2VR13	2VR14	2VR14A	2VR15	2VR16	2VR17
2	1206			OWN PRE	-	-	-	-	-	-
C-F-1	V2 21206-002-33		ISI-21206-002	ISI	-	-	-	-	-	-
C5.11	21206-002-33		12" ELBOW TO PIPE	AUG	-	-	-	-	-	-
2	1206			OWN PRE	-	-	-	-	-	-
C-F-1	V2 21206-002-33 A		ISI-21206-002	ISI	-	-	-	-	-	-
C5.11	21206-002-33 A		12" PIPE TO PIPE	AUG	-	-	-	-	-	-
2	1206			OWN PRE	-	-	-	-	-	-
C-F-1	V2 21206-002-34	ISI/UT/	ISI-21206-002	ISI	-	-	-	-	s	-
C5.11	21206-002-34		12" PIPE TO ELBOW	AUG	-	-	-	-	-	-
2	1206			OWN PRE	-	-	-	-	-	-
C-F-1	V2 21206-002-35	ISI/UT/	ISI-21206-002	ISI	-	-	-	-	s	-
C5.11	21206-002-35		12" ELBOW TO PIPE (AI 87-0131)	AUG	-	-	-	-	-	-
2	1206			OWN PRE	-	-	-	-	-	-
C-F-1	V2 21206-002-35 A		ISI-21206-002	ISI	-	-	-	-	-	-
C5.11	21206-002-35 A		12" PIPE TO PIPE	AUG	-	-	-	-	-	-
2	1206			OWN PRE	-	-	-	-	-	-
C-F-1	V2 21206-002-36	ISI/UT/	ISI-21206-002	ISI	-	-	-	-	s	-
C5.11	21206-002-36		12" PIPE TO TEE	AUG	-	-	-	-	-	-
2	1206			OWN PRE	-	-	-	-	-	-
C-F-1	V2 21206-002-4		ISI-21206-002	ISI	-	-	-	-	-	-
C5.11	21206-002-4		12" REDUCER TO PIPE	AUG	-	-	-	-	-	-
2	1206			OWN PRE	-	-	-	-	-	-
C-F-1	V2 21206-002-6		ISI-21206-002	ISI	-	-	-	-	-	-
C5.11	21206-002-6		12" PIPE TO REDUCER	AUG	-	-	-	-	-	-
2	1206			OWN PRE	-	-	-	-	-	-
C-F-1	V2 21206-002-7		ISI-21206-002	ISI	-	-	-	-	-	-
C5.11	21206-002-7		10" REDUCER TO VALVE	AUG	-	-	-	-	-	-
2	1206			OWN PRE	-	-	-	-	-	-
C-F-1	V2 21206-002-8		ISI-21206-002	ISI	-	-	-	-	-	-
C5.11	21206-002-8		10" VALVE TO REDUCER	AUG	-	-	-	-	-	-

Southern Nuclear Operating Company
3rd Interval
VOGTLE-2 ISI PLAN, VERSION 3.0

Category, Item No., Class	Summary No./CompID/System	Scope / Method / Procedure	Dwg/ISO No. Comp. Desc. Code Case		Period 1		Period 2			Period 3	
					2VR13	2VR14	2VR14A	2VR15	2VR16	2VR17	2VR18
2	1206			OWN	-	-	-	-	-	-	-
				PRE	-	-	-	-	-	-	-
C-F-1	V2 21206-002-9		ISI-21206-002	ISI	-	-	-	-	-	-	-
C5.11	21206-002-9		12" REDUCER TO PIPE	AUG	-	-	-	-	-	-	-
2	1206			OWN	-	-	-	-	-	-	-
				PRE	-	-	-	-	-	-	-
C-F-1	V2 21206-003-1		ISI-21206-003	ISI	-	-	-	-	-	-	-
C5.11	21206-003-1		10" VALVE TO PIPE	AUG	-	-	-	-	-	-	-
2	1206			OWN	-	-	-	-	-	-	-
				PRE	-	-	-	-	-	-	-
C-F-1	V2 21206-003-10		ISI-21206-003	ISI	-	-	-	-	-	-	-
C5.11	21206-003-10		10" PIPE TO TEE	AUG	-	-	-	-	-	-	-
2	1206			OWN	-	-	-	-	-	-	-
				PRE	-	-	-	-	-	-	-
C-F-1	V2 21206-003-3		ISI-21206-003	ISI	-	-	-	-	-	-	-
C5.11	21206-003-3		10" PIPE TO VALVE	AUG	-	-	-	-	-	-	-
2	1206			OWN	-	-	-	-	-	-	-
				PRE	-	-	-	-	-	-	-
C-F-1	V2 21206-003-4		ISI-21206-003	ISI	-	-	-	-	-	-	-
C5.11	21206-003-4		10" VALVE TO PIPE	AUG	-	-	-	-	-	-	-
2	1206			OWN	-	-	-	-	-	-	-
				PRE	-	-	-	-	-	-	-
C-F-1	V2 21206-003-5		ISI-21206-003	ISI	-	-	-	-	-	-	-
C5.11	21206-003-5		10" PIPE TO ELBOW	AUG	-	-	-	-	-	-	-
2	1206			OWN	-	-	-	-	-	-	-
				PRE	-	-	-	-	-	-	-
C-F-1	V2 21206-003-6		ISI-21206-003	ISI	-	-	-	-	-	-	-
C5.11	21206-003-6		10" ELBOW TO PIPE	AUG	-	-	-	-	-	-	-
2	1206			OWN	-	-	-	-	-	-	-
				PRE	-	-	-	-	-	-	-
C-F-1	V2 21206-003-7		ISI-21206-003	ISI	-	-	-	-	-	-	-
C5.11	21206-003-7		10" PIPE TO ELBOW	AUG	-	-	-	-	-	-	-
2	1206			OWN	-	-	-	-	-	-	-
				PRE	-	-	-	-	-	-	-
C-F-1	V2 21206-003-8		ISI-21206-003	ISI	-	-	-	-	-	-	-
C5.11	21206-003-8		10" ELBOW TO PIPE	AUG	-	-	-	-	-	-	-
2	1206			OWN	-	-	-	-	-	-	-
				PRE	-	-	-	-	-	-	-
C-F-1	V2 21206-004-1		ISI-21206-004	ISI	-	-	-	-	-	-	-
C5.11	21206-004-1		10" VALVE TO PIPE	AUG	-	-	-	-	-	-	-

Southern Nuclear Operating Company
3rd Interval
VOGTLE-2 ISI PLAN, VERSION 3.0

Category, Item No., Class	Summary No./ComplD/System	Scope / Method / Procedure	Dwg/ISO No. Comp. Desc. Code Case		Period 1		Period 2			Period 3	
					2VR13	2VR14	2VR14A	2VR15	2VR16	2VR17	2VR18
2	1206			OWN	-	-	-	-	-	-	-
				PRE	-	-	-	-	-	-	-
C-F-1	V2 21206-004-10		ISI-21206-004	ISI	-	-	-	-	-	-	-
C5.11	21206-004-10		12" PIPE TO FLANGE	AUG	-	-	-	-	-	-	-
2	1206			OWN	-	-	-	-	-	-	-
				PRE	-	-	-	-	-	-	-
C-F-1	V2 21206-004-11		ISI-21206-004	ISI	-	-	-	-	-	-	-
C5.11	21206-004-11		12" FLANGE TO REDUCER (AI 87-0131)	AUG	-	-	-	-	-	-	-
2	1206			OWN	-	-	-	-	-	-	-
				PRE	-	-	-	-	-	-	-
C-F-1	V2 21206-004-12		ISI-21206-004	ISI	-	-	-	-	-	-	-
C5.11	21206-004-12		10" REDUCER TO FLANGE (AI 87-0131)	AUG	-	-	-	-	-	-	-
2	1206			OWN	-	-	-	-	-	-	-
				PRE	-	-	-	-	-	-	-
C-F-1	V2 21206-004-2		ISI-21206-004	ISI	-	-	-	-	-	-	-
C5.11	21206-004-2		10" PIPE TO PIPE	AUG	-	-	-	-	-	-	-
2	1206			OWN	-	-	-	-	-	-	-
				PRE	-	-	-	-	-	-	-
C-F-1	V2 21206-004-3		ISI-21206-004	ISI	-	-	-	-	-	-	-
C5.11	21206-004-3		10" PIPE TO VALVE	AUG	-	-	-	-	-	-	-
2	1206			OWN	-	-	-	-	-	-	-
				PRE	-	-	-	-	-	-	-
C-F-1	V2 21206-004-4		ISI-21206-004	ISI	-	-	-	-	-	-	-
C5.11	21206-004-4		10" VALVE TO REDUCER (AI 87-0131)	AUG	-	-	-	-	-	-	-
2	1206			OWN	-	-	-	-	-	-	-
				PRE	-	-	-	-	-	-	-
C-F-1	V2 21206-004-5		ISI-21206-004	ISI	-	-	-	-	-	-	-
C5.11	21206-004-5		12" REDUCER TO TEE (AI 87-0131)	AUG	-	-	-	-	-	-	-
2	1206			OWN	-	-	-	-	-	-	-
				PRE	-	-	-	-	-	-	-
C-F-1	V2 21206-004-6		ISI-21206-004	ISI	-	-	-	-	-	-	-
C5.11	21206-004-6		12" TEE TO PIPE	AUG	-	-	-	-	-	-	-
2	1206			OWN	-	-	-	-	-	-	-
				PRE	-	-	-	-	-	-	-
C-F-1	V2 21206-004-7		ISI-21206-004	ISI	-	-	-	-	-	-	-
C5.11	21206-004-7		12" PIPE TO ELBOW	AUG	-	-	-	-	-	-	-
2	1206			OWN	-	-	-	-	-	-	-
				PRE	-	-	-	-	-	-	-

Southern Nuclear Operating Company
3rd Interval
VOGTLE-2 ISI PLAN, VERSION 3.0

Category, Item No., Class	Summary No./CompID/System	Scope / Method / Procedure	Dwg/ISO No. Comp. Desc. Code Case		Period 1		Period 2			Period 3	
					2VR13	2VR14	2VR14A	2VR15	2VR16	2VR17	2VR18
C-F-1	V2 21206-004-8		ISI-21206-004	ISI	-	-	-	-	-	-	-
C5.11	21206-004-8	12" ELBOW TO FLANGE		AUG	-	-	-	-	-	-	-
2	1206			OWN	-	-	-	-	-	-	-
				PRE	-	-	-	-	-	-	-
C-F-1	V2 21206-004-9		ISI-21206-004	ISI	-	-	-	-	-	-	-
C5.11	21206-004-9	12" FLANGE TO PIPE		AUG	-	-	-	-	-	-	-
2	1206			OWN	-	-	-	-	-	-	-
				PRE	-	-	-	-	-	-	-
C-F-1	V2 21206-005-1		ISI-21206-005	ISI	-	-	-	-	-	-	-
C5.11	21206-005-1	8" FLANGE TO PIPE (AI 87-0131)		AUG	-	-	-	-	-	-	-
2	1206			OWN	-	-	-	-	-	-	-
				PRE	-	-	-	-	-	-	-
C-F-1	V2 21206-005-11		ISI-21206-005	ISI	-	-	-	-	-	-	-
C5.11	21206-005-11	8" PIPE TO ELBOW		AUG	-	-	-	-	-	-	-
2	1206			OWN	-	-	-	-	-	-	-
				PRE	-	-	-	-	-	-	-
C-F-1	V2 21206-005-12		ISI-21206-005	ISI	-	-	-	-	-	-	-
C5.11	21206-005-12	8" ELBOW TO PIPE		AUG	-	-	-	-	-	-	-
2	1206			OWN	-	-	-	-	-	-	-
				PRE	-	-	-	-	-	-	-
C-F-1	V2 21206-005-13		ISI-21206-005	ISI	-	-	-	-	-	-	-
C5.11	21206-005-13	8" PIPE TO ELBOW		AUG	-	-	-	-	-	-	-
2	1206			OWN	-	-	-	-	-	-	-
				PRE	-	-	-	-	-	-	-
C-F-1	V2 21206-005-14		ISI-21206-005	ISI	-	-	-	-	-	-	-
C5.11	21206-005-14	8" ELBOW TO PIPE		AUG	-	-	-	-	-	-	-
2	1206			OWN	-	-	-	-	-	-	-
				PRE	-	-	-	-	-	-	-
C-F-1	V2 21206-005-16		ISI-21206-005	ISI	-	-	-	-	-	-	-
C5.11	21206-005-16	8" PIPE TO PIPE		AUG	-	-	-	-	-	-	-
2	1206			OWN	-	-	-	-	-	-	-
				PRE	-	-	-	-	-	-	-
C-F-1	V2 21206-005-17		ISI-21206-005	ISI	-	-	-	-	-	-	-
C5.11	21206-005-17	8" PIPE TO ELBOW		AUG	-	-	-	-	-	-	-
2	1206			OWN	-	-	-	-	-	-	-
				PRE	-	-	-	-	-	-	-
C-F-1	V2 21206-005-18		ISI-21206-005	ISI	-	-	-	-	-	-	-
C5.11	21206-005-18	8" ELBOW TO PIPE		AUG	-	-	-	-	-	-	-
2	1206			OWN	-	-	-	-	-	-	-
				PRE	-	-	-	-	-	-	-

Southern Nuclear Operating Company
3rd Interval
VOGTLE-2 ISI PLAN, VERSION 3.0

Category, Item No., Class	Summary No./CompID/System	Scope / Method / Procedure	Dwg/ISO No. Comp. Desc. Code Case		Period 1		Period 2			Period 3	
					2VR13	2VR14	2VR14A	2VR15	2VR16	2VR17	2VR18
C-F-1	V2 21206-005-19		ISI-21206-005	ISI	-	-	-	-	-	-	-
C5.11	21206-005-19	8" PIPE TO ELBOW		AUG	-	-	-	-	-	-	-
2	1206			OWN	-	-	-	-	-	-	-
				PRE	-	-	-	-	-	-	-
C-F-1	V2 21206-005-2		ISI-21206-005	ISI	-	-	-	-	-	-	-
C5.11	21206-005-2	8" PIPE TO ELBOW (AI 87-0131)		AUG	-	-	-	-	-	-	-
2	1206			OWN	-	-	-	-	-	-	-
				PRE	-	-	-	-	-	-	-
C-F-1	V2 21206-005-20		ISI-21206-005	ISI	-	-	-	-	-	-	-
C5.11	21206-005-20	8" ELBOW TO PIPE		AUG	-	-	-	-	-	-	-
2	1206			OWN	-	-	-	-	-	-	-
				PRE	-	-	-	-	-	-	-
C-F-1	V2 21206-005-21		ISI-21206-005	ISI	-	-	-	-	-	-	-
C5.11	21206-005-21	8" PIPE TO ELBOW		AUG	-	-	-	-	-	-	-
2	1206			OWN	-	-	-	-	-	-	-
				PRE	-	-	-	-	-	-	-
C-F-1	V2 21206-005-22		ISI-21206-005	ISI	-	-	-	-	-	-	-
C5.11	21206-005-22	8" ELBOW TO PIPE		AUG	-	-	-	-	-	-	-
2	1206			OWN	-	-	-	-	-	-	-
				PRE	-	-	-	-	-	-	-
C-F-1	V2 21206-005-24		ISI-21206-005	ISI	-	-	-	-	-	-	-
C5.11	21206-005-24	8" PIPE TO ELBOW		AUG	-	-	-	-	-	-	-
2	1206			OWN	-	-	-	-	-	-	-
				PRE	-	-	-	-	-	-	-
C-F-1	V2 21206-005-25		ISI-21206-005	ISI	-	-	-	-	-	-	-
C5.11	21206-005-25	8" ELBOW TO PIPE		AUG	-	-	-	-	-	-	-
2	1206			OWN	-	-	-	-	-	-	-
				PRE	-	-	-	-	-	-	-
C-F-1	V2 21206-005-26		ISI-21206-005	ISI	-	-	-	-	-	-	-
C5.11	21206-005-26	8" PIPE TO PIPE		AUG	-	-	-	-	-	-	-
2	1206			OWN	-	-	-	-	-	-	-
				PRE	-	-	-	-	-	-	-
C-F-1	V2 21206-005-27		ISI-21206-005	ISI	-	-	-	-	-	-	-
C5.11	21206-005-27	8" PIPE TO ELBOW		AUG	-	-	-	-	-	-	-
2	1206			OWN	-	-	-	-	-	-	-
				PRE	-	-	-	-	-	-	-
C-F-1	V2 21206-005-28		ISI-21206-005	ISI	-	-	-	-	-	-	-
C5.11	21206-005-28	8" ELBOW TO PIPE		AUG	-	-	-	-	-	-	-
2	1206			OWN	-	-	-	-	-	-	-
				PRE	-	-	-	-	-	-	-

Southern Nuclear Operating Company
3rd Interval
VOGTLE-2 ISI PLAN, VERSION 3.0

Category, Item No., Class	Summary No./CompID/System	Scope / Method / Procedure	Dwg/ISO No. Comp. Desc. Code Case	Period 1		Period 2		Period 3	
				2VR13	2VR14	2VR14A	2VR15	2VR16	2VR17
C-F-1 C5.11 2	V2 21206-005-29 21206-005-29 1206		ISI-21206-005 8" PIPE TO ELBOW	ISI AUG OWN PRE	- - - -	- - - -	- - - -	- - - -	- - - -
C-F-1 C5.11 2	V2 21206-005-3 21206-005-3 1206		ISI-21206-005 8" ELBOW TO PIPE (AI 87-0131)	ISI AUG OWN PRE	- - - -	- - - -	- - - -	- - - -	- - - -
C-F-1 C5.11 2	V2 21206-005-30 21206-005-30 1206		ISI-21206-005 8" ELBOW TO PIPE	ISI AUG OWN PRE	- - - -	- - - -	- - - -	- - - -	- - - -
C-F-1 C5.11 2	V2 21206-005-32 21206-005-32 1206		ISI-21206-005 8" PIPE TO PIPE	ISI AUG OWN PRE	- - - -	- - - -	- - - -	- - - -	- - - -
C-F-1 C5.11 2	V2 21206-005-33 21206-005-33 1206		ISI-21206-005 8" PIPE TO PIPE	ISI AUG OWN PRE	- - - -	- - - -	- - - -	- - - -	- - - -
C-F-1 C5.11 2	V2 21206-005-34 21206-005-34 1206		ISI-21206-005 8" PIPE TO PIPE	ISI AUG OWN PRE	- - - -	- - - -	- - - -	- - - -	- - - -
C-F-1 C5.11 2	V2 21206-005-37 21206-005-37 1206		ISI-21206-005 8" PIPE TO ELBOW	ISI AUG OWN PRE	- - - -	- - - -	- - - -	- - - -	- - - -
C-F-1 C5.11 2	V2 21206-005-38 21206-005-38 1206		ISI-21206-005 8" ELBOW TO PIPE	ISI AUG OWN PRE	- - - -	- - - -	- - - -	- - - -	- - - -
C-F-1 C5.11 2	V2 21206-005-39 21206-005-39 1206		ISI-21206-005 8" PIPE TO ELBOW	ISI AUG OWN PRE	- - - -	- - - -	- - - -	- - - -	- - - -
C-F-1 C5.11 2	V2 21206-005-40 21206-005-40 1206		ISI-21206-005 8" ELBOW TO PIPE	ISI AUG OWN PRE	- - - -	- - - -	- - - -	- - - -	- - - -

Southern Nuclear Operating Company
3rd Interval
VOGTLE-2 ISI PLAN, VERSION 3.0

Category, Item No., Class	Summary No./ComplD/System	Scope / Method / Procedure	Dwg/ISO No. Comp. Desc. Code Case		Period 1		Period 2			Period 3	
					2VR13	2VR14	2VR14A	2VR15	2VR16	2VR17	2VR18
C-F-1 C5.11 2	V2 21206-005-41 21206-005-41 1206		ISI-21206-005 8" PIPE TO ELBOW	ISI AUG OWN PRE	-	-	-	-	-	-	-
C-F-1 C5.11 2	V2 21206-005-42 21206-005-42 1206		ISI-21206-005 8" ELBOW TO PIPE	ISI AUG OWN PRE	-	-	-	-	-	-	-
C-F-1 C5.11 2	V2 21206-005-43 21206-005-43 1206		ISI-21206-005 8" PIPE TO ELBOW	ISI AUG OWN PRE	-	-	-	-	-	-	-
C-F-1 C5.11 2	V2 21206-005-44 21206-005-44 1206		ISI-21206-005 8" ELBOW TO PIPE	ISI AUG OWN PRE	-	-	-	-	-	-	-
C-F-1 C5.11 2	V2 21206-005-45 21206-005-45 1206		ISI-21206-005 8" PIPE TO ELBOW	ISI AUG OWN PRE	-	-	-	-	-	-	-
C-F-1 C5.11 2	V2 21206-005-46 21206-005-46 1206		ISI-21206-005 8" ELBOW TO PIPE	ISI AUG OWN PRE	-	-	-	-	-	-	-
C-F-1 C5.11 2	V2 21206-005-47 21206-005-47 1206		ISI-21206-005 8" PIPE TO VALVE	ISI AUG OWN PRE	-	-	-	-	-	-	-
C-F-1 C5.11 2	V2 21206-005-5 21206-005-5 1206		ISI-21206-005 8" PIPE TO ELBOW	ISI AUG OWN PRE	-	-	-	-	-	-	-
C-F-1 C5.11 2	V2 21206-005-6 21206-005-6 1206		ISI-21206-005 8" ELBOW TO PIPE (AI 87-0131)	ISI AUG OWN PRE	-	-	-	-	-	-	-
C-F-1 C5.11 2	V2 21206-005-7 21206-005-7 1206		ISI-21206-005 8" PIPE TO PIPE	ISI AUG OWN PRE	-	-	-	-	-	-	-

Southern Nuclear Operating Company
3rd Interval
VOGTLE-2 ISI PLAN, VERSION 3.0

Category, Item No., Class	Summary No./ComplID/System	Scope / Method / Procedure	Dwg/ISO No. Comp. Desc. Code Case		Period 1		Period 2			Period 3	
					2VR13	2VR14	2VR14A	2VR15	2VR16	2VR17	2VR18
C-F-1 C5.11 2	V2 21206-005-8 21206-005-8 1206		ISI-21206-005 8" PIPE TO ELBOW (AI 87-0131)	ISI AUG OWN PRE	-	-	-	-	-	-	-
C-F-1 C5.11 2	V2 21206-005-9 21206-005-9 1206		ISI-21206-005 8" ELBOW TO PIPE	ISI AUG OWN PRE	-	-	-	-	-	-	-
C-F-1 C5.11 2	V2 21206-006-1 21206-006-1 1206		ISI-21206-006 8" FLANGE TO PIPE (AI 87-0131)	ISI AUG OWN PRE	-	-	-	-	-	-	-
C-F-1 C5.11 2	V2 21206-006-10 21206-006-10 1206		ISI-21206-006 8" PIPE TO ELBOW	ISI AUG OWN PRE	-	-	-	-	-	-	-
C-F-1 C5.11 2	V2 21206-006-11 21206-006-11 1206		ISI-21206-006 8" ELBOW TO PIPE	ISI AUG OWN PRE	-	-	-	-	-	-	-
C-F-1 C5.11 2	V2 21206-006-12 21206-006-12 1206		ISI-21206-006 8" PIPE TO ELBOW	ISI AUG OWN PRE	-	-	-	-	-	-	-
C-F-1 C5.11 2	V2 21206-006-13 21206-006-13 1206		ISI-21206-006 8" ELBOW TO PIPE	ISI AUG OWN PRE	-	-	-	-	-	-	-
C-F-1 C5.11 2	V2 21206-006-14 21206-006-14 1206		ISI-21206-006 8" PIPE TO ELBOW	ISI AUG OWN PRE	-	-	-	-	-	-	-
C-F-1 C5.11 2	V2 21206-006-15 21206-006-15 1206		ISI-21206-006 8" ELBOW TO PIPE	ISI AUG OWN PRE	-	-	-	-	-	-	-
C-F-1 C5.11 2	V2 21206-006-16 21206-006-16 1206		ISI-21206-006 8" PIPE TO ELBOW	ISI AUG OWN PRE	-	-	-	-	-	-	-

Southern Nuclear Operating Company
3rd Interval
VOGTLE-2 ISI PLAN, VERSION 3.0

Category, Item No., Class	Summary No./CompID/System	Scope / Method / Procedure	Dwg/ISO No. Comp. Desc. Code Case		Period 1		Period 2			Period 3	
					2VR13	2VR14	2VR14A	2VR15	2VR16	2VR17	2VR18
C-F-1	V2 21206-006-17		ISI-21206-006	ISI	-	-	-	-	-	-	-
C5.11	21206-006-17		8" ELBOW TO PIPE	AUG	-	-	-	-	-	-	-
2	1206			OWN	-	-	-	-	-	-	-
				PRE	-	-	-	-	-	-	-
C-F-1	V2 21206-006-19		ISI-21206-006	ISI	-	-	-	-	-	-	-
C5.11	21206-006-19		8" PIPE TO PIPE	AUG	-	-	-	-	-	-	-
2	1206			OWN	-	-	-	-	-	-	-
				PRE	-	-	-	-	-	-	-
C-F-1	V2 21206-006-2		ISI-21206-006	ISI	-	-	-	-	-	-	-
C5.11	21206-006-2		8" PIPE TO ELBOW (AI 87-0131)	AUG	-	-	-	-	-	-	-
2	1206			OWN	-	-	-	-	-	-	-
				PRE	-	-	-	-	-	-	-
C-F-1	V2 21206-006-20		ISI-21206-006	ISI	-	-	-	-	-	-	-
C5.11	21206-006-20		8" PIPE TO PIPE	AUG	-	-	-	-	-	-	-
2	1206			OWN	-	-	-	-	-	-	-
				PRE	-	-	-	-	-	-	-
C-F-1	V2 21206-006-21		ISI-21206-006	ISI	-	-	-	-	-	-	-
C5.11	21206-006-21		8" PIPE TO PIPE	AUG	-	-	-	-	-	-	-
2	1206			OWN	-	-	-	-	-	-	-
				PRE	-	-	-	-	-	-	-
C-F-1	V2 21206-006-22		ISI-21206-006	ISI	-	-	-	-	-	-	-
C5.11	21206-006-22		8" PIPE TO ELBOW	AUG	-	-	-	-	-	-	-
2	1206			OWN	-	-	-	-	-	-	-
				PRE	-	-	-	-	-	-	-
C-F-1	V2 21206-006-23		ISI-21206-006	ISI	-	-	-	-	-	-	-
C5.11	21206-006-23		8" ELBOW TO PIPE	AUG	-	-	-	-	-	-	-
2	1206			OWN	-	-	-	-	-	-	-
				PRE	-	-	-	-	-	-	-
C-F-1	V2 21206-006-24		ISI-21206-006	ISI	-	-	-	-	-	-	-
C5.11	21206-006-24		8" PIPE TO ELBOW	AUG	-	-	-	-	-	-	-
2	1206			OWN	-	-	-	-	-	-	-
				PRE	-	-	-	-	-	-	-
C-F-1	V2 21206-006-25		ISI-21206-006	ISI	-	-	-	-	-	-	-
C5.11	21206-006-25		8" ELBOW TO PIPE	AUG	-	-	-	-	-	-	-
2	1206			OWN	-	-	-	-	-	-	-
				PRE	-	-	-	-	-	-	-
C-F-1	V2 21206-006-26		ISI-21206-006	ISI	-	-	-	-	-	-	-
C5.11	21206-006-26		8" PIPE TO PIPE	AUG	-	-	-	-	-	-	-
2	1206			OWN	-	-	-	-	-	-	-
				PRE	-	-	-	-	-	-	-

Southern Nuclear Operating Company
3rd Interval
VOGTLE-2 ISI PLAN, VERSION 3.0

Category, Item No., Class	Summary No./ComplD/System	Scope / Method / Procedure	Dwg/ISO No. Comp. Desc. Code Case		Period 1		Period 2			Period 3	
					2VR13	2VR14	2VR14A	2VR15	2VR16	2VR17	2VR18
C-F-1 C5.11 2	V2 21206-006-28 21206-006-28 1206		ISI-21206-006 8" PIPE TO ELBOW	ISI AUG OWN PRE	-	-	-	-	-	-	-
C-F-1 C5.11 2	V2 21206-006-29 21206-006-29 1206		ISI-21206-006 8" ELBOW TO PIPE	ISI AUG OWN PRE	-	-	-	-	-	-	-
C-F-1 C5.11 2	V2 21206-006-3 21206-006-3 1206		ISI-21206-006 8" ELBOW TO PIPE (AI 87-0131)	ISI AUG OWN PRE	-	-	-	-	-	-	-
C-F-1 C5.11 2	V2 21206-006-30 21206-006-30 1206		ISI-21206-006 8" PIPE TO ELBOW	ISI AUG OWN PRE	-	-	-	-	-	-	-
C-F-1 C5.11 2	V2 21206-006-31 21206-006-31 1206		ISI-21206-006 8" ELBOW TO ELBOW	ISI AUG OWN PRE	-	-	-	-	-	-	-
C-F-1 C5.11 2	V2 21206-006-32 21206-006-32 1206		ISI-21206-006 8" ELBOW TO PIPE	ISI AUG OWN PRE	-	-	-	-	-	-	-
C-F-1 C5.11 2	V2 21206-006-33 21206-006-33 1206		ISI-21206-006 8" PIPE TO PIPE	ISI AUG OWN PRE	-	-	-	-	-	-	-
C-F-1 C5.11 2	V2 21206-006-35 21206-006-35 1206		ISI-21206-006 8" PIPE TO PIPE	ISI AUG OWN PRE	-	-	-	-	-	-	-
C-F-1 C5.11 2	V2 21206-006-36 21206-006-36 1206		ISI-21206-006 8" PIPE TO ELBOW	ISI AUG OWN PRE	-	-	-	-	-	-	-
C-F-1 C5.11 2	V2 21206-006-37 21206-006-37 1206		ISI-21206-006 8" ELBOW TO PIPE	ISI AUG OWN PRE	-	-	-	-	-	-	-

Southern Nuclear Operating Company
3rd Interval
VOGTLE-2 ISI PLAN, VERSION 3.0

Category, Item No., Class	Summary No./CompID/System	Scope / Method / Procedure	Dwg/ISO No. Comp. Desc. Code Case		Period 1		Period 2			Period 3	
					2VR13	2VR14	2VR14A	2VR15	2VR16	2VR17	2VR18
C-F-1 C5.11 2	V2 21206-006-38 21206-006-38 1206		ISI-21206-006 8" PIPE TO ELBOW	ISI AUG OWN PRE	-	-	-	-	-	-	-
C-F-1 C5.11 2	V2 21206-006-39 21206-006-39 1206		ISI-21206-006 8" ELBOW TO ELBOW	ISI AUG OWN PRE	-	-	-	-	-	-	-
C-F-1 C5.11 2	V2 21206-006-4 21206-006-4 1206		ISI-21206-006 8" PIPE TO ELBOW	ISI AUG OWN PRE	-	-	-	-	-	-	-
C-F-1 C5.11 2	V2 21206-006-40 21206-006-40 1206		ISI-21206-006 8" PIPE TO PIPE	ISI AUG OWN PRE	-	-	-	-	-	-	-
C-F-1 C5.11 2	V2 21206-006-42 21206-006-42 1206		ISI-21206-006 8" PIPE TO PIPE	ISI AUG OWN PRE	-	-	-	-	-	-	-
C-F-1 C5.11 2	V2 21206-006-42 A 21206-006-42 A 1206		ISI-21206-006 8" PIPE TO PIPE	ISI AUG OWN PRE	-	-	-	-	-	-	-
C-F-1 C5.11 2	V2 21206-006-43 21206-006-43 1206		ISI-21206-006 8" PIPE TO ELBOW	ISI AUG OWN PRE	-	-	-	-	-	-	-
C-F-1 C5.11 2	V2 21206-006-44 21206-006-44 1206		ISI-21206-006 8" ELBOW TO PIPE	ISI AUG OWN PRE	-	-	-	-	-	-	-
C-F-1 C5.11 2	V2 21206-006-45 21206-006-45 1206		ISI-21206-006 8" PIPE TO ELBOW	ISI AUG OWN PRE	-	-	-	-	-	-	-
C-F-1 C5.11 2	V2 21206-006-46 21206-006-46 1206		ISI-21206-006 8" ELBOW TO PIPE	ISI AUG OWN PRE	-	-	-	-	-	-	-

Southern Nuclear Operating Company
3rd Interval
VOGTLE-2 ISI PLAN, VERSION 3.0

Category, Item No., Class	Summary No./CompID/System	Scope / Method / Procedure	Dwg/ISO No. Comp. Desc. Code Case		Period 1		Period 2			Period 3	
					2VR13	2VR14	2VR14A	2VR15	2VR16	2VR17	2VR18
C-F-1 C5.11 2	V2 21206-006-47 21206-006-47 1206		ISI-21206-006 8" PIPE TO ELBOW	ISI AUG OWN PRE	-	-	-	-	-	-	-
C-F-1 C5.11 2	V2 21206-006-48 21206-006-48 1206		ISI-21206-006 8" ELBOW TO PIPE	ISI AUG OWN PRE	-	-	-	-	-	-	-
C-F-1 C5.11 2	V2 21206-006-49 21206-006-49 1206		ISI-21206-006 8" PIPE TO VALVE	ISI AUG OWN PRE	-	-	-	-	-	-	-
C-F-1 C5.11 2	V2 21206-006-5 21206-006-5 1206		ISI-21206-006 8" ELBOW TO PIPE	ISI AUG OWN PRE	-	-	-	-	-	-	-
C-F-1 C5.11 2	V2 21206-006-7 21206-006-7 1206		ISI-21206-006 8" PIPE TO ELBOW (AI 87-0131)	ISI AUG OWN PRE	-	-	-	-	-	-	-
C-F-1 C5.11 2	V2 21206-006-8 21206-006-8 1206		ISI-21206-006 8" ELBOW TO PIPE	ISI AUG OWN PRE	-	-	-	-	-	-	-
C-F-1 C5.11 2	V2 21206-007-1 21206-007-1 1206		ISI-21206-007 8" VALVE TO PIPE	ISI AUG OWN PRE	-	-	-	-	-	-	-
C-F-1 C5.11 2	V2 21206-007-10 21206-007-10 1206		ISI-21206-007 8" VALVE TO PIPE	ISI AUG OWN PRE	-	-	-	-	-	-	-
C-F-1 C5.11 2	V2 21206-007-11 21206-007-11 1206		ISI-21206-007 8" PIPE TO TEE	ISI AUG OWN PRE	-	-	-	-	-	-	-
C-F-1 C5.11 2	V2 21206-007-12 21206-007-12 1206		ISI-21206-007 8" TEE TO PIPE	ISI AUG OWN PRE	-	-	-	-	-	-	-

Southern Nuclear Operating Company
3rd Interval
VOGTLE-2 ISI PLAN, VERSION 3.0

Category, Item No., Class	Summary No./CompID/System	Scope / Method / Procedure	Dwg/ISO No. Comp. Desc. Code Case		Period 1		Period 2			Period 3	
					2VR13	2VR14	2VR14A	2VR15	2VR16	2VR17	2VR18
C-F-1 C5.11 2	V2 21206-007-13 21206-007-13 1206		ISI-21206-007 8" PIPE TO VALVE	ISI AUG OWN PRE	- - - -	- - - -	- - - -	- - - -	- - - -	- - - -	- - - -
C-F-1 C5.11 2	V2 21206-007-14 21206-007-14 1206		ISI-21206-007 6" TEE TO PIPE (AI 87-0131)	ISI AUG OWN PRE	- - - -	- - - -	- - - -	- - - -	- - - -	- - - -	- - - -
C-F-1 C5.11 2	V2 21206-007-15 21206-007-15 1206		ISI-21206-007 6" PIPE TO FLANGE	ISI AUG OWN PRE	- - - -	- - - -	- - - -	- - - -	- - - -	- - - -	- - - -
C-F-1 C5.11 2	V2 21206-007-3 21206-007-3 1206		ISI-21206-007 8" PIPE TO ELBOW	ISI AUG OWN PRE	- - - -	- - - -	- - - -	- - - -	- - - -	- - - -	- - - -
C-F-1 C5.11 2	V2 21206-007-4 21206-007-4 1206		ISI-21206-007 8" ELBOW TO NECK EXTENSION	ISI AUG OWN PRE	- - - -	- - - -	- - - -	- - - -	- - - -	- - - -	- - - -
C-F-1 C5.11 2	V2 21206-007-5 21206-007-5 1206		ISI-21206-007 8" NECK EXTENSION TO FLUED HEAD	ISI AUG OWN PRE	- - - -	- - - -	- - - -	- - - -	- - - -	- - - -	- - - -
C-F-1 C5.11 2	V2 21206-007-6 21206-007-6 1206		ISI-21206-007 FLUED HEAD TO 8" PIPE	ISI AUG OWN PRE	- - - -	- - - -	- - - -	- - - -	- - - -	- - - -	- - - -
C-F-1 C5.11 2	V2 21206-007-7 21206-007-7 1206		ISI-21206-007 8" PIPE TO ELBOW	ISI AUG OWN PRE	- - - -	- - - -	- - - -	- - - -	- - - -	- - - -	- - - -
C-F-1 C5.11 2	V2 21206-007-8 21206-007-8 1206		ISI-21206-007 8" ELBOW TO PIPE	ISI AUG OWN PRE	- - - -	- - - -	- - - -	- - - -	- - - -	- - - -	- - - -
C-F-1 C5.11 2	V2 21206-007-9 21206-007-9 1206		ISI-21206-007 8" PIPE TO VALVE	ISI AUG OWN PRE	- - - -	- - - -	- - - -	- - - -	- - - -	- - - -	- - - -

Southern Nuclear Operating Company
3rd Interval
VOGTLE-2 ISI PLAN, VERSION 3.0

Category, Item No., Class	Summary No./CompID/System	Scope / Method / Procedure	Dwg/ISO No. Comp. Desc. Code Case		Period 1		Period 2			Period 3	
					2VR13	2VR14	2VR14A	2VR15	2VR16	2VR17	2VR18
C-F-1	V2 21206-008-19		ISI-21206-008	ISI	-	-	-	-	-	-	-
C5.11	21206-008-19		6" PIPE TO FLANGE	AUG	-	-	-	-	-	-	-
2	1206			OWN	-	-	-	-	-	-	-
				PRE	-	-	-	-	-	-	-
C-F-1	V2 21206-008-2		ISI-21206-008	ISI	-	-	-	-	-	-	-
C5.11	21206-008-2		8" PIPE TO NECK EXTENSION	AUG	-	-	-	-	-	-	-
2	1206			OWN	-	-	-	-	-	-	-
				PRE	-	-	-	-	-	-	-
C-F-1	V2 21206-008-3		ISI-21206-008	ISI	-	-	-	-	-	-	-
C5.11	21206-008-3		8" NECK EXTENSION TO FLUED HEAD	AUG	-	-	-	-	-	-	-
2	1206			OWN	-	-	-	-	-	-	-
				PRE	-	-	-	-	-	-	-
C-F-1	V2 21206-008-4		ISI-21206-008	ISI	-	-	-	-	-	-	-
C5.11	21206-008-4		FLUED HEAD TO 8" PIPE	AUG	-	-	-	-	-	-	-
2	1206			OWN	-	-	-	-	-	-	-
				PRE	-	-	-	-	-	-	-
C-F-1	V2 21206-008-5		ISI-21206-008	ISI	-	-	-	-	-	-	-
C5.11	21206-008-5		8" PIPE TO ELBOW	AUG	-	-	-	-	-	-	-
2	1206			OWN	-	-	-	-	-	-	-
				PRE	-	-	-	-	-	-	-
C-F-1	V2 21206-008-6		ISI-21206-008	ISI	-	-	-	-	-	-	-
C5.11	21206-008-6		8" ELBOW TO PIPE	AUG	-	-	-	-	-	-	-
2	1206			OWN	-	-	-	-	-	-	-
				PRE	-	-	-	-	-	-	-
C-F-1	V2 21206-008-7		ISI-21206-008	ISI	-	-	-	-	-	-	-
C5.11	21206-008-7		8" PIPE TO ELBOW	AUG	-	-	-	-	-	-	-
2	1206			OWN	-	-	-	-	-	-	-
				PRE	-	-	-	-	-	-	-
C-F-1	V2 21206-008-8		ISI-21206-008	ISI	-	-	-	-	-	-	-
C5.11	21206-008-8		8" ELBOW TO PIPE	AUG	-	-	-	-	-	-	-
2	1206			OWN	-	-	-	-	-	-	-
				PRE	-	-	-	-	-	-	-
C-F-1	V2 21206-008-9		ISI-21206-008	ISI	-	-	-	-	-	-	-
C5.11	21206-008-9		8" PIPE TO ELBOW	AUG	-	-	-	-	-	-	-
2	1206			OWN	-	-	-	-	-	-	-
				PRE	-	-	-	-	-	-	-
C-F-1	V2 21208-137-1		ISI-21208-137	ISI	-	-	-	-	-	-	-
C5.11	21208-137-1		8" VALVE TO PIPE	AUG	-	-	-	-	-	-	-
2	1208			OWN	-	-	-	-	-	-	-
				PRE	-	-	-	-	-	-	-

Southern Nuclear Operating Company
3rd Interval
VOGTLE-2 ISI PLAN, VERSION 3.0

Category, Item No., Class	Summary No./CompID/System	Scope / Method / Procedure	Dwg/ISO No. Comp. Desc. Code Case		Period 1		Period 2		Period 3	
					2VR13	2VR14	2VR14A	2VR15	2VR16	2VR17
C-F-1 C5.11 2	V2 21208-137-10 21208-137-10 1208	ISI/UT/NMP-ES-024-501	ISI-21208-137 8" PIPE TO ELBOW (AI 87-0131)	ISI AUG OWN PRE	- s - -	- - - -	- - - -	- - - -	- - - -	- - - -
C-F-1 C5.11 2	V2 21208-137-11 21208-137-11 1208		ISI-21208-137 8" ELBOW TO PIPE	ISI AUG OWN PRE	- - - -	- - - -	- - - -	- - - -	- - - -	- - - -
C-F-1 C5.11 2	V2 21208-137-12 21208-137-12 1208		ISI-21208-137 8" PIPE TO VALVE	ISI AUG OWN PRE	- - - -	- - - -	- - - -	- - - -	- - - -	- - - -
C-F-1 C5.11 2	V2 21208-137-13 21208-137-13 1208	ISI/UT/	ISI-21208-137 8" VALVE TO PIPE (AI 87-0131)	ISI AUG OWN PRE	- - - -	- - - -	- - - -	- - - -	s - - -	- - - -
C-F-1 C5.11 2	V2 21208-137-14 21208-137-14 1208	ISI/UT/	ISI-21208-137 8" PIPE TO ELBOW	ISI AUG OWN PRE	- - - -	- - - -	- - - -	- - - -	s - - -	- - - -
C-F-1 C5.11 2	V2 21208-137-15 21208-137-15 1208		ISI-21208-137 8" ELBOW TO PIPE	ISI AUG OWN PRE	- - - -	- - - -	- - - -	- - - -	- - - -	- - - -
C-F-1 C5.11 2	V2 21208-137-16 21208-137-16 1208		ISI-21208-137 8" PIPE TO ELBOW	ISI AUG OWN PRE	- - - -	- - - -	- - - -	- - - -	- - - -	- - - -
C-F-1 C5.11 2	V2 21208-137-17 21208-137-17 1208		ISI-21208-137 8" ELBOW TO PIPE	ISI AUG OWN PRE	- - - -	- - - -	- - - -	- - - -	- - - -	- - - -
C-F-1 C5.11 2	V2 21208-137-18 21208-137-18 1208		ISI-21208-137 8" PIPE TO ELBOW	ISI AUG OWN PRE	- - - -	- - - -	- - - -	- - - -	- - - -	- - - -
C-F-1 C5.11 2	V2 21208-137-19 21208-137-19 1208		ISI-21208-137 8" ELBOW TO PIPE	ISI AUG OWN PRE	- - - -	- - - -	- - - -	- - - -	- - - -	- - - -

Southern Nuclear Operating Company
3rd Interval
VOGTLE-2 ISI PLAN, VERSION 3.0

Category, Item No., Class	Summary No./CompID/System	Scope / Method / Procedure	Dwg/ISO No. Comp. Desc. Code Case	Period 1		Period 2			Period 3	
				2VR13	2VR14	2VR14A	2VR15	2VR16	2VR17	2VR18
C-F-1 C5.11 2	V2 21208-137-2 21208-137-2 1208		ISI-21208-137 8" PIPE TO ELBOW	ISI AUG OWN PRE	- - - -	- - - -	- - - -	- - - -	- - - -	- - - -
C-F-1 C5.11 2	V2 21208-137-21 21208-137-21 1208		ISI-21208-137 8" PIPE TO TEE	ISI AUG OWN PRE	- - - -	- - - -	- - - -	- - - -	- - - -	- - - -
C-F-1 C5.11 2	V2 21208-137-3 21208-137-3 1208		ISI-21208-137 8" ELBOW TO PIPE	ISI AUG OWN PRE	- - - -	- - - -	- - - -	- - - -	- - - -	- - - -
C-F-1 C5.11 2	V2 21208-137-4 21208-137-4 1208		ISI-21208-137 8" PIPE TO ELBOW	ISI AUG OWN PRE	- - - -	- - - -	- - - -	- - - -	- - - -	- - - -
C-F-1 C5.11 2	V2 21208-137-5 21208-137-5 1208		ISI-21208-137 8" ELBOW TO PIPE	ISI AUG OWN PRE	- - - -	- - - -	- - - -	- - - -	- - - -	- - - -
C-F-1 C5.11 2	V2 21208-137-6 21208-137-6 1208		ISI-21208-137 8" PIPE TO TEE (AI 87-0131)	ISI AUG OWN PRE	- - - -	- - - -	- - - -	- - - -	- - - -	- - - -
C-F-1 C5.11 2	V2 21208-137-7 21208-137-7 1208		ISI-21208-137 8" TEE TO PIPE	ISI AUG OWN PRE	- - - -	- - - -	- - - -	- - - -	- - - -	- - - -
C-F-1 C5.11 2	V2 21208-137-8 21208-137-8 1208		ISI-21208-137 8" PIPE TO ELBOW	ISI AUG OWN PRE	- - - -	- - - -	- - - -	- - - -	- - - -	- - - -
C-F-1 C5.11 2	V2 21208-137-9 21208-137-9 1208		ISI-21208-137 8" ELBOW TO PIPE	ISI AUG OWN PRE	- - - -	- - - -	- - - -	- - - -	- - - -	- - - -
C-F-1 C5.11 2	V2 21208-139-1 21208-139-1 1208		ISI-21208-139 8" TEE TO PIPE	ISI AUG OWN PRE	- - - -	- - - -	- - - -	- - - -	- - - -	- - - -

Southern Nuclear Operating Company
3rd Interval
VOGTLE-2 ISI PLAN, VERSION 3.0

Category, Item No., Class	Summary No./ComplD/System	Scope / Method / Procedure	Dwg/ISO No. Comp. Desc. Code Case		Period 1		Period 2			Period 3	
					2VR13	2VR14	2VR14A	2VR15	2VR16	2VR17	2VR18
C-F-1 C5.11 2	V2 21208-139-10 21208-139-10 1208		ISI-21208-139 6" PIPE TO PIPE	ISI AUG OWN PRE	-	-	-	-	-	-	-
C-F-1 C5.11 2	V2 21208-139-11 21208-139-11 1208	ISI/UT/NMP-ES-024-501	ISI-21208-139 6" PIPE TO ELBOW	ISI AUG OWN PRE	-	s	-	-	-	-	-
C-F-1 C5.11 2	V2 21208-139-12 21208-139-12 1208		ISI-21208-139 6" ELBOW TO PIPE	ISI AUG OWN PRE	-	-	-	-	-	-	-
C-F-1 C5.11 2	V2 21208-139-13 21208-139-13 1208		ISI-21208-139 6" PIPE TO VALVE	ISI AUG OWN PRE	-	-	-	-	-	-	-
C-F-1 C5.11 2	V2 21208-139-14 21208-139-14 1208	ISI/UT/	ISI-21208-139 6" VALVE TO PIPE	ISI AUG OWN PRE	-	-	-	-	-	s	-
C-F-1 C5.11 2	V2 21208-139-15 21208-139-15 1208		ISI-21208-139 6" PIPE TO TEE	ISI AUG OWN PRE	-	-	-	-	-	-	-
C-F-1 C5.11 2	V2 21208-139-16 21208-139-16 1208		ISI-21208-139 6" TEE TO PIPE	ISI AUG OWN PRE	-	-	-	-	-	-	-
C-F-1 C5.11 2	V2 21208-139-17 21208-139-17 1208		ISI-21208-139 6" PIPE TO CAP	ISI AUG OWN PRE	-	-	-	-	-	-	-
C-F-1 C5.11 2	V2 21208-139-18 21208-139-18 1208		ISI-21208-139 6" TEE TO PIPE	ISI AUG OWN PRE	-	-	-	-	-	-	-
C-F-1 C5.11 2	V2 21208-139-19 21208-139-19 1208		ISI-21208-139 6" PIPE TO ELBOW	ISI AUG OWN PRE	-	-	-	-	-	-	-

Southern Nuclear Operating Company
3rd Interval
VOGTLE-2 ISI PLAN, VERSION 3.0

Category, Item No., Class	Summary No./ComplD/System	Scope / Method / Procedure	Dwg/ISO No. Comp. Desc. Code Case		Period 1		Period 2			Period 3	
					2VR13	2VR14	2VR14A	2VR15	2VR16	2VR17	2VR18
C-F-1 C5.11 2	V2 21208-139-2 21208-139-2 1208		ISI-21208-139 8" PIPE TO TEE	ISI AUG OWN PRE	-	-	-	-	-	-	-
C-F-1 C5.11 2	V2 21208-139-20 21208-139-20 1208		ISI-21208-139 6" ELBOW TO PIPE	ISI AUG OWN PRE	-	-	-	-	-	-	-
C-F-1 C5.11 2	V2 21208-139-21 21208-139-21 1208		ISI-21208-139 6" PIPE TO TEE	ISI AUG OWN PRE	-	-	-	-	-	-	-
C-F-1 C5.11 2	V2 21208-139-22 21208-139-22 1208		ISI-21208-139 6" TEE TO PIPE	ISI AUG OWN PRE	-	-	-	-	-	-	-
C-F-1 C5.11 2	V2 21208-139-23 21208-139-23 1208		ISI-21208-139 6" PIPE TO CAP	ISI AUG OWN PRE	-	-	-	-	-	-	-
C-F-1 C5.11 2	V2 21208-139-24 21208-139-24 1208		ISI-21208-139 6" TEE TO PIPE	ISI AUG OWN PRE	-	-	-	-	-	-	-
C-F-1 C5.11 2	V2 21208-139-25 21208-139-25 1208		ISI-21208-139 6" PIPE TO PIPE	ISI AUG OWN PRE	-	-	-	-	-	-	-
C-F-1 C5.11 2	V2 21208-139-26 21208-139-26 1208		ISI-21208-139 6" PIPE TO ELBOW	ISI AUG OWN PRE	-	-	-	-	-	-	-
C-F-1 C5.11 2	V2 21208-139-27 21208-139-27 1208		ISI-21208-139 6" ELBOW TO PIPE	ISI AUG OWN PRE	-	-	-	-	-	-	-
C-F-1 C5.11 2	V2 21208-139-28 21208-139-28 1208		ISI-21208-139 6" PIPE TO FLANGE	ISI AUG OWN PRE	-	-	-	-	-	-	-

Southern Nuclear Operating Company
3rd Interval
VOGTLE-2 ISI PLAN, VERSION 3.0

Category, Item No., Class	Summary No./CompID/System	Scope / Method / Procedure	Dwg/ISO No. Comp. Desc. Code Case		Period 1		Period 2		Period 3	
					2VR13	2VR14	2VR14A	2VR15	2VR16	2VR17
C-F-1	V2 21208-139-29		ISI-21208-139	ISI	-	-	-	-	-	-
C5.11	21208-139-29		6" FLANGE TO PIPE	AUG	-	-	-	-	-	-
2	1208			OWN	-	-	-	-	-	-
				PRE	-	-	-	-	-	-
C-F-1	V2 21208-139-3		ISI-21208-139	ISI	-	-	-	-	-	-
C5.11	21208-139-3		8" TEE TO PIPE	AUG	-	-	-	-	-	-
2	1208			OWN	-	-	-	-	-	-
				PRE	-	-	-	-	-	-
C-F-1	V2 21208-139-30		ISI-21208-139	ISI	-	-	-	-	-	-
C5.11	21208-139-30		6" PIPE TO ELBOW	AUG	-	-	-	-	-	-
2	1208			OWN	-	-	-	-	-	-
				PRE	-	-	-	-	-	-
C-F-1	V2 21208-139-31		ISI-21208-139	ISI	-	-	-	-	-	-
C5.11	21208-139-31		6" ELBOW TO PIPE	AUG	-	-	-	-	-	-
2	1208			OWN	-	-	-	-	-	-
				PRE	-	-	-	-	-	-
C-F-1	V2 21208-139-33		ISI-21208-139	ISI	-	-	-	-	-	-
C5.11	21208-139-33		6" PIPE TO FLANGE	AUG	-	-	-	-	-	-
2	1208			OWN	-	-	-	-	-	-
				PRE	-	-	-	-	-	-
C-F-1	V2 21208-139-34		ISI-21208-139	ISI	-	-	-	-	-	-
C5.11	21208-139-34		6" FLANGE TO PIPE	AUG	-	-	-	-	-	-
2	1208			OWN	-	-	-	-	-	-
				PRE	-	-	-	-	-	-
C-F-1	V2 21208-139-35		ISI-21208-139	ISI	-	-	-	-	-	-
C5.11	21208-139-35		6" PIPE TO FLANGE	AUG	-	-	-	-	-	-
2	1208			OWN	-	-	-	-	-	-
				PRE	-	-	-	-	-	-
C-F-1	V2 21208-139-4		ISI-21208-139	ISI	-	-	-	-	-	-
C5.11	21208-139-4		8" PIPE TO REDUCER	AUG	-	-	-	-	-	-
2	1208			OWN	-	-	-	-	-	-
				PRE	-	-	-	-	-	-
C-F-1	V2 21208-139-5		ISI-21208-139	ISI	-	-	-	-	-	-
C5.11	21208-139-5		6" REDUCER TO PIPE	AUG	-	-	-	-	-	-
2	1208			OWN	-	-	-	-	-	-
				PRE	-	-	-	-	-	-
C-F-1	V2 21208-139-6		ISI-21208-139	ISI	-	-	-	-	-	-
C5.11	21208-139-6		6" PIPE TO PIPE	AUG	-	-	-	-	-	-
2	1208			OWN	-	-	-	-	-	-
				PRE	-	-	-	-	-	-

Southern Nuclear Operating Company
3rd Interval
VOGTLE-2 ISI PLAN, VERSION 3.0

Category, Item No., Class	Summary No./ComplD/System	Scope / Method / Procedure	Dwg/ISO No. Comp. Desc. Code Case		Period 1		Period 2			Period 3	
					2VR13	2VR14	2VR14A	2VR15	2VR16	2VR17	2VR18
C-F-1	V2 21208-139-7		ISI-21208-139	ISI	-	-	-	-	-	-	-
C5.11	21208-139-7		6" PIPE TO ELBOW	AUG	-	-	-	-	-	-	-
2	1208			OWN	-	-	-	-	-	-	-
				PRE	-	-	-	-	-	-	-
C-F-1	V2 21208-139-8		ISI-21208-139	ISI	-	-	-	-	-	-	-
C5.11	21208-139-8		6" ELBOW TO PIPE	AUG	-	-	-	-	-	-	-
2	1208			OWN	-	-	-	-	-	-	-
				PRE	-	-	-	-	-	-	-
C-F-1	V2 21208-141-1		ISI-21208-141	ISI	-	-	-	-	-	-	-
C5.11	21208-141-1		8" TEE TO PIPE	AUG	-	-	-	-	-	-	-
2	1208			OWN	-	-	-	-	-	-	-
				PRE	-	-	-	-	-	-	-
C-F-1	V2 21208-141-10		ISI-21208-141	ISI	-	-	-	-	-	-	-
C5.11	21208-141-10		8" PIPE TO TEE	AUG	-	-	-	-	-	-	-
2	1208			OWN	-	-	-	-	-	-	-
				PRE	-	-	-	-	-	-	-
C-F-1	V2 21208-141-11		ISI-21208-141	ISI	-	-	-	-	-	-	-
C5.11	21208-141-11		8" TEE TO PIPE	AUG	-	-	-	-	-	-	-
2	1208			OWN	-	-	-	-	-	-	-
				PRE	-	-	-	-	-	-	-
C-F-1	V2 21208-141-12		ISI-21208-141	ISI	-	-	-	-	-	-	-
C5.11	21208-141-12		8" PIPE TO REDUCER	AUG	-	-	-	-	-	-	-
2	1208			OWN	-	-	-	-	-	-	-
				PRE	-	-	-	-	-	-	-
C-F-1	V2 21208-141-13		ISI-21208-141	ISI	-	-	-	-	-	-	-
C5.11	21208-141-13		6" REDUCER TO PIPE	AUG	-	-	-	-	-	-	-
2	1208			OWN	-	-	-	-	-	-	-
				PRE	-	-	-	-	-	-	-
C-F-1	V2 21208-141-14	ISI/UT/NMP-ES-024-501	ISI-21208-141	ISI	-	s	-	-	-	-	-
C5.11	21208-141-14		6" PIPE TO ELBOW	AUG	-	-	-	-	-	-	-
2	1208			OWN	-	-	-	-	-	-	-
				PRE	-	-	-	-	-	-	-
C-F-1	V2 21208-141-15		ISI-21208-141	ISI	-	-	-	-	-	-	-
C5.11	21208-141-15		6" ELBOW TO PIPE	AUG	-	-	-	-	-	-	-
2	1208			OWN	-	-	-	-	-	-	-
				PRE	-	-	-	-	-	-	-
C-F-1	V2 21208-141-16		ISI-21208-141	ISI	-	-	-	-	-	-	-
C5.11	21208-141-16		6" PIPE TO VALVE	AUG	-	-	-	-	-	-	-
2	1208			OWN	-	-	-	-	-	-	-
				PRE	-	-	-	-	-	-	-

Southern Nuclear Operating Company
3rd Interval
VOGTLE-2 ISI PLAN, VERSION 3.0

Category, Item No., Class	Summary No./ComplD/System	Scope / Method / Procedure	Dwg/ISO No. Comp. Desc. Code Case		Period 1		Period 2			Period 3	
					2VR13	2VR14	2VR14A	2VR15	2VR16	2VR17	2VR18
C-F-1 C5.11 2	V2 21208-141-17 21208-141-17 1208		ISI-21208-141 6" VALVE TO PIPE	ISI AUG OWN PRE	-	-	-	-	-	-	-
C-F-1 C5.11 2	V2 21208-141-18 21208-141-18 1208		ISI-21208-141 6" PIPE TO TEE	ISI AUG OWN PRE	-	-	-	-	-	-	-
C-F-1 C5.11 2	V2 21208-141-19 21208-141-19 1208		ISI-21208-141 6" TEE TO PIPE	ISI AUG OWN PRE	-	-	-	-	-	-	-
C-F-1 C5.11 2	V2 21208-141-2 21208-141-2 1208		ISI-21208-141 8" PIPE TO REDUCER (AI 87-0131)	ISI AUG OWN PRE	-	-	-	-	-	-	-
C-F-1 C5.11 2	V2 21208-141-20 21208-141-20 1208		ISI-21208-141 6" PIPE TO CAP	ISI AUG OWN PRE	-	-	-	-	-	-	-
C-F-1 C5.11 2	V2 21208-141-21 21208-141-21 1208		ISI-21208-141 6" TEE TO PIPE	ISI AUG OWN PRE	-	-	-	-	-	-	-
C-F-1 C5.11 2	V2 21208-141-22 21208-141-22 1208		ISI-21208-141 6" PIPE TO ELBOW	ISI AUG OWN PRE	-	-	-	-	-	-	-
C-F-1 C5.11 2	V2 21208-141-23 21208-141-23 1208		ISI-21208-141 6" ELBOW TO PIPE	ISI AUG OWN PRE	-	-	-	-	-	-	-
C-F-1 C5.11 2	V2 21208-141-24 21208-141-24 1208		ISI-21208-141 6" PIPE TO TEE	ISI AUG OWN PRE	-	-	-	-	-	-	-
C-F-1 C5.11 2	V2 21208-141-25 21208-141-25 1208		ISI-21208-141 6" TEE TO PIPE	ISI AUG OWN PRE	-	-	-	-	-	-	-

Southern Nuclear Operating Company
3rd Interval
VOGTLE-2 ISI PLAN, VERSION 3.0

Category, Item No., Class	Summary No./ComplD/System	Scope / Method / Procedure	Dwg/ISO No. Comp. Desc. Code Case		Period 1		Period 2			Period 3	
					2VR13	2VR14	2VR14A	2VR15	2VR16	2VR17	2VR18
C-F-1 C5.11 2	V2 21208-141-26 21208-141-26 1208		ISI-21208-141 6" PIPE TO CAP	ISI AUG OWN PRE	-	-	-	-	-	-	-
C-F-1 C5.11 2	V2 21208-141-27 21208-141-27 1208		ISI-21208-141 6" TEE TO PIPE	ISI AUG OWN PRE	-	-	-	-	-	-	-
C-F-1 C5.11 2	V2 21208-141-28 21208-141-28 1208		ISI-21208-141 6" PIPE TO PIPE	ISI AUG OWN PRE	-	-	-	-	-	-	-
C-F-1 C5.11 2	V2 21208-141-29 21208-141-29 1208		ISI-21208-141 6" PIPE TO ELBOW	ISI AUG OWN PRE	-	-	-	-	-	-	-
C-F-1 C5.11 2	V2 21208-141-30 21208-141-30 1208		ISI-21208-141 6" ELBOW TO PIPE	ISI AUG OWN PRE	-	-	-	-	-	-	-
C-F-1 C5.11 2	V2 21208-141-31 21208-141-31 1208		ISI-21208-141 6" PIPE TO FLANGE	ISI AUG OWN PRE	-	-	-	-	-	-	-
C-F-1 C5.11 2	V2 21208-141-32 21208-141-32 1208		ISI-21208-141 6" FLANGE TO PIPE	ISI AUG OWN PRE	-	-	-	-	-	-	-
C-F-1 C5.11 2	V2 21208-141-33 21208-141-33 1208		ISI-21208-141 6" PIPE TO ELBOW	ISI AUG OWN PRE	-	-	-	-	-	-	-
C-F-1 C5.11 2	V2 21208-141-34 21208-141-34 1208		ISI-21208-141 6" ELBOW TO PIPE	ISI AUG OWN PRE	-	-	-	-	-	-	-
C-F-1 C5.11 2	V2 21208-141-35 21208-141-35 1208		ISI-21208-141 6" PIPE TO FLANGE	ISI AUG OWN PRE	-	-	-	-	-	-	-

Southern Nuclear Operating Company
3rd Interval
VOGTLE-2 ISI PLAN, VERSION 3.0

Category, Item No., Class	Summary No./CompID/System	Scope / Method / Procedure	Dwg/ISO No. Comp. Desc. Code Case		Period 1		Period 2			Period 3	
					2VR13	2VR14	2VR14A	2VR15	2VR16	2VR17	2VR18
C-F-1 C5.11 2	V2 21208-141-36 21208-141-36 1208		ISI-21208-141 6" FLANGE TO PIPE	ISI AUG OWN PRE	-	-	-	-	-	-	-
C-F-1 C5.11 2	V2 21208-141-37 21208-141-37 1208		ISI-21208-141 6" PIPE TO FLANGE	ISI AUG OWN PRE	-	-	-	-	-	-	-
C-F-1 C5.11 2	V2 21208-141-5 21208-141-5 1208		ISI-21208-141 8" TEE TO PIPE	ISI AUG OWN PRE	-	-	-	-	-	-	-
C-F-1 C5.11 2	V2 21208-141-5 A 21208-141-5 A 1208		ISI-21208-141 8" PIPE TO PIPE	ISI AUG OWN PRE	-	-	-	-	-	-	-
C-F-1 C5.11 2	V2 21208-141-7 21208-141-7 1208		ISI-21208-141 8" PIPE TO PIPE	ISI AUG OWN PRE	-	-	-	-	-	-	-
C-F-1 C5.11 2	V2 21208-141-8 21208-141-8 1208		ISI-21208-141 8" PIPE TO TEE	ISI AUG OWN PRE	-	-	-	-	-	-	-
C-F-1 C5.11 2	V2 21208-141-9 21208-141-9 1208		ISI-21208-141 8" VALVE TO PIPE	ISI AUG OWN PRE	-	-	-	-	-	-	-
C-F-1 C5.11 2	V2 21208-411-1 21208-411-1 1208		ISI-21208-411 8" VALVE TO PIPE	ISI AUG OWN PRE	-	-	-	-	-	-	-
C-F-1 C5.11 2	V2 21208-411-10 21208-411-10 1208		ISI-21208-411 8" PIPE TO PIPE	ISI AUG OWN PRE	-	-	-	-	-	-	-
C-F-1 C5.11 2	V2 21208-411-11 21208-411-11 1208		ISI-21208-411 8" PIPE TO PIPE	ISI AUG OWN PRE	-	-	-	-	-	-	-

Southern Nuclear Operating Company
3rd Interval
VOGTLE-2 ISI PLAN, VERSION 3.0

Category, Item No., Class	Summary No./ComplD/System	Scope / Method / Procedure	Dwg/ISO No. Comp. Desc. Code Case		Period 1		Period 2		Period 3	
					2VR13	2VR14	2VR14A	2VR15	2VR16	2VR17
C-F-1	V2 21208-411-12		ISI-21208-411	ISI	-	-	-	-	-	-
C5.11	21208-411-12		8" PIPE TO ELBOW	AUG	-	-	-	-	-	-
2	1208			OWN	-	-	-	-	-	-
				PRE	-	-	-	-	-	-
C-F-1	V2 21208-411-13		ISI-21208-411	ISI	-	-	-	-	-	-
C5.11	21208-411-13		8" ELBOW TO PIPE	AUG	-	-	-	-	-	-
2	1208			OWN	-	-	-	-	-	-
				PRE	-	-	-	-	-	-
C-F-1	V2 21208-411-15		ISI-21208-411	ISI	-	-	-	-	-	-
C5.11	21208-411-15		8" PIPE TO ELBOW	AUG	-	-	-	-	-	-
2	1208			OWN	-	-	-	-	-	-
				PRE	-	-	-	-	-	-
C-F-1	V2 21208-411-16		ISI-21208-411	ISI	-	-	-	-	-	-
C5.11	21208-411-16		8" ELBOW TO PIPE	AUG	-	-	-	-	-	-
2	1208			OWN	-	-	-	-	-	-
				PRE	-	-	-	-	-	-
C-F-1	V2 21208-411-17		ISI-21208-411	ISI	-	-	-	-	-	-
C5.11	21208-411-17		8" PIPE TO ELBOW	AUG	-	-	-	-	-	-
2	1208			OWN	-	-	-	-	-	-
				PRE	-	-	-	-	-	-
C-F-1	V2 21208-411-18		ISI-21208-411	ISI	-	-	-	-	-	-
C5.11	21208-411-18		8" ELBOW TO PIPE	AUG	-	-	-	-	-	-
2	1208			OWN	-	-	-	-	-	-
				PRE	-	-	-	-	-	-
C-F-1	V2 21208-411-19	ISI/UT/	ISI-21208-411	ISI	-	-	-	s	-	-
C5.11	21208-411-19		8" PIPE TO ELBOW (AI 87-0131)	AUG	-	-	-	-	-	-
2	1208			OWN	-	-	-	-	-	-
				PRE	-	-	-	-	-	-
C-F-1	V2 21208-411-2		ISI-21208-411	ISI	-	-	-	-	-	-
C5.11	21208-411-2		8" PIPE TO VALVE	AUG	-	-	-	-	-	-
2	1208			OWN	-	-	-	-	-	-
				PRE	-	-	-	-	-	-
C-F-1	V2 21208-411-20		ISI-21208-411	ISI	-	-	-	-	-	-
C5.11	21208-411-20		8" ELBOW TO PIPE	AUG	-	-	-	-	-	-
2	1208			OWN	-	-	-	-	-	-
				PRE	-	-	-	-	-	-
C-F-1	V2 21208-411-21		ISI-21208-411	ISI	-	-	-	-	-	-
C5.11	21208-411-21		8" PIPE TO PIPE	AUG	-	-	-	-	-	-
2	1208			OWN	-	-	-	-	-	-
				PRE	-	-	-	-	-	-

Southern Nuclear Operating Company
3rd Interval
VOGTLE-2 ISI PLAN, VERSION 3.0

Category, Item No., Class	Summary No./CompID/System	Scope / Method / Procedure	Dwg/ISO No. Comp. Desc. Code Case		Period 1		Period 2			Period 3	
					2VR13	2VR14	2VR14A	2VR15	2VR16	2VR17	2VR18
C-F-1 C5.11 2	V2 21208-411-22 21208-411-22 1208		ISI-21208-411 8" PIPE TO PIPE	ISI AUG OWN PRE	-	-	-	-	-	-	-
C-F-1 C5.11 2	V2 21208-411-23 21208-411-23 1208		ISI-21208-411 8" PIPE TO TEE	ISI AUG OWN PRE	-	-	-	-	-	-	-
C-F-1 C5.11 2	V2 21208-411-24 21208-411-24 1208		ISI-21208-411 6" VALVE TO PIPE (AI 87-0131)	ISI AUG OWN PRE	-	-	-	-	-	-	-
C-F-1 C5.11 2	V2 21208-411-25 21208-411-25 1208	ISI/UT/NMP-ES-024-501	ISI-21208-411 6" PIPE TO ELBOW (AI 87-0131)	ISI AUG OWN PRE	-	s	-	-	-	-	-
C-F-1 C5.11 2	V2 21208-411-26 21208-411-26 1208		ISI-21208-411 6" ELBOW TO PIPE	ISI AUG OWN PRE	-	-	-	-	-	-	-
C-F-1 C5.11 2	V2 21208-411-27 21208-411-27 1208		ISI-21208-411 6" PIPE TO PIPE	ISI AUG OWN PRE	-	-	-	-	-	-	-
C-F-1 C5.11 2	V2 21208-411-28 21208-411-28 1208		ISI-21208-411 6" PIPE TO ELBOW	ISI AUG OWN PRE	-	-	-	-	-	-	-
C-F-1 C5.11 2	V2 21208-411-29 21208-411-29 1208		ISI-21208-411 6" ELBOW TO PIPE	ISI AUG OWN PRE	-	-	-	-	-	-	-
C-F-1 C5.11 2	V2 21208-411-3 21208-411-3 1208		ISI-21208-411 8" VALVE TO PIPE	ISI AUG OWN PRE	-	-	-	-	-	-	-
C-F-1 C5.11 2	V2 21208-411-31 21208-411-31 1208		ISI-21208-411 6" PIPE TO ELBOW	ISI AUG OWN PRE	-	-	-	-	-	-	-

Southern Nuclear Operating Company
3rd Interval
VOGTLE-2 ISI PLAN, VERSION 3.0

Category, Item No., Class	Summary No./ComplD/System	Scope / Method / Procedure	Dwg/ISO No. Comp. Desc. Code Case		Period 1		Period 2			Period 3	
					2VR13	2VR14	2VR14A	2VR15	2VR16	2VR17	2VR18
C-F-1 C5.11 2	V2 21208-411-32 21208-411-32 1208		ISI-21208-411 6" ELBOW TO PIPE	ISI AUG OWN PRE	- - - -	- - - -	- - - -	- - - -	- - - -	- - - -	- - - -
C-F-1 C5.11 2	V2 21208-411-33 21208-411-33 1208		ISI-21208-411 6" PIPE TO ELBOW	ISI AUG OWN PRE	- - - -	- - - -	- - - -	- - - -	- - - -	- - - -	- - - -
C-F-1 C5.11 2	V2 21208-411-34 21208-411-34 1208		ISI-21208-411 6" ELBOW TO PIPE	ISI AUG OWN PRE	- - - -	- - - -	- - - -	- - - -	- - - -	- - - -	- - - -
C-F-1 C5.11 2	V2 21208-411-35 21208-411-35 1208		ISI-21208-411 6" PIPE TO REDUCER (AI 87-0131)	ISI AUG OWN PRE	- - - -	- - - -	- - - -	- - - -	- - - -	- - - -	- - - -
C-F-1 C5.11 2	V2 21208-411-36 21208-411-36 1208		ISI-21208-411 8" REDUCER TO PIPE	ISI AUG OWN PRE	- - - -	- - - -	- - - -	- - - -	- - - -	- - - -	- - - -
C-F-1 C5.11 2	V2 21208-411-37 21208-411-37 1208		ISI-21208-411 8" PIPE TO TEE	ISI AUG OWN PRE	- - - -	- - - -	- - - -	- - - -	- - - -	- - - -	- - - -
C-F-1 C5.11 2	V2 21208-411-38 21208-411-38 1208		ISI-21208-411 8" TEE TO PIPE	ISI AUG OWN PRE	- - - -	- - - -	- - - -	- - - -	- - - -	- - - -	- - - -
C-F-1 C5.11 2	V2 21208-411-39 21208-411-39 1208		ISI-21208-411 8" PIPE TO ELBOW	ISI AUG OWN PRE	- - - -	- - - -	- - - -	- - - -	- - - -	- - - -	- - - -
C-F-1 C5.11 2	V2 21208-411-4 21208-411-4 1208		ISI-21208-411 8" PIPE TO ELBOW	ISI AUG OWN PRE	- - - -	- - - -	- - - -	- - - -	- - - -	- - - -	- - - -
C-F-1 C5.11 2	V2 21208-411-40 21208-411-40 1208		ISI-21208-411 8" ELBOW TO PIPE	ISI AUG OWN PRE	- - - -	- - - -	- - - -	- - - -	- - - -	- - - -	- - - -

Southern Nuclear Operating Company
3rd Interval
VOGTLE-2 ISI PLAN, VERSION 3.0

Category, Item No., Class	Summary No./ComplD/System	Scope / Method / Procedure	Dwg/ISO No. Comp. Desc. Code Case		Period 1		Period 2			Period 3	
					2VR13	2VR14	2VR14A	2VR15	2VR16	2VR17	2VR18
C-F-1 C5.11 2	V2 21208-411-42 21208-411-42 1208		ISI-21208-411 8" PIPE TO PIPE	ISI AUG OWN PRE	-	-	-	-	-	-	-
C-F-1 C5.11 2	V2 21208-411-43 21208-411-43 1208		ISI-21208-411 8" PIPE TO PIPE	ISI AUG OWN PRE	-	-	-	-	-	-	-
C-F-1 C5.11 2	V2 21208-411-44 21208-411-44 1208		ISI-21208-411 8" PIPE TO ELBOW	ISI AUG OWN PRE	-	-	-	-	-	-	-
C-F-1 C5.11 2	V2 21208-411-45 21208-411-45 1208		ISI-21208-411 8" ELBOW TO PIPE	ISI AUG OWN PRE	-	-	-	-	-	-	-
C-F-1 C5.11 2	V2 21208-411-46 21208-411-46 1208		ISI-21208-411 8" PIPE TO ELBOW	ISI AUG OWN PRE	-	-	-	-	-	-	-
C-F-1 C5.11 2	V2 21208-411-47 21208-411-47 1208		ISI-21208-411 8" ELBOW TO PIPE	ISI AUG OWN PRE	-	-	-	-	-	-	-
C-F-1 C5.11 2	V2 21208-411-48 21208-411-48 1208		ISI-21208-411 8" PIPE TO TEE	ISI AUG OWN PRE	-	-	-	-	-	-	-
C-F-1 C5.11 2	V2 21208-411-5 21208-411-5 1208		ISI-21208-411 8" ELBOW TO PIPE	ISI AUG OWN PRE	-	-	-	-	-	-	-
C-F-1 C5.11 2	V2 21208-411-7 21208-411-7 1208		ISI-21208-411 8" PIPE TO ELBOW	ISI AUG OWN PRE	-	-	-	-	-	-	-
C-F-1 C5.11 2	V2 21208-411-8 21208-411-8 1208		ISI-21208-411 8" ELBOW TO PIPE	ISI AUG OWN PRE	-	-	-	-	-	-	-

Southern Nuclear Operating Company
3rd Interval
VOGTLE-2 ISI PLAN, VERSION 3.0

Category, Item No., Class	Summary No./ComplD/System	Scope / Method / Procedure	Dwg/ISO No. Comp. Desc. Code Case		Period 1		Period 2			Period 3	
					2VR13	2VR14	2VR14A	2VR15	2VR16	2VR17	2VR18
C-F-1 C5.21 2	V2 21204-057-1 21204-057-1 1204		ISI-21204-057 3" PIPE TO VALVE	ISI AUG OWN PRE	-	-	-	-	-	-	-
C-F-1 C5.21 2	V2 21204-057-1 A 21204-057-1 A 1204		ISI-21204-057 3" TEE TO PIPE	ISI AUG OWN PRE	-	-	-	-	-	-	-
C-F-1 C5.21 2	V2 21204-057-1 B 21204-057-1 B 1204		ISI-21204-057 3" PIPE TO TEE	ISI AUG OWN PRE	-	-	-	-	-	-	-
C-F-1 C5.21 2	V2 21204-057-10 21204-057-10 1204	ISI/UT/	ISI-21204-057 4" PIPE TO ELBOW (AI 87-0131)	ISI AUG OWN PRE	-	-	-	s	-	-	-
C-F-1 C5.21 2	V2 21204-057-11 21204-057-11 1204		ISI-21204-057 4" ELBOW TO PIPE	ISI AUG OWN PRE	-	-	-	-	-	-	-
C-F-1 C5.21 2	V2 21204-057-12 21204-057-12 1204		ISI-21204-057 4" PIPE TO PIPE	ISI AUG OWN PRE	-	-	-	-	-	-	-
C-F-1 C5.21 2	V2 21204-057-13 21204-057-13 1204		ISI-21204-057 4" PIPE TO ELBOW	ISI AUG OWN PRE	-	-	-	-	-	-	-
C-F-1 C5.21 2	V2 21204-057-14 21204-057-14 1204		ISI-21204-057 4" ELBOW TO PIPE	ISI AUG OWN PRE	-	-	-	-	-	-	-
C-F-1 C5.21 2	V2 21204-057-15 21204-057-15 1204		ISI-21204-057 4" PIPE TO VALVE	ISI AUG OWN PRE	-	-	-	-	-	-	-
C-F-1 C5.21 2	V2 21204-057-16 21204-057-16 1204		ISI-21204-057 4" VALVE TO PIPE	ISI AUG OWN PRE	-	-	-	-	-	-	-

Southern Nuclear Operating Company
3rd Interval
VOGTLE-2 ISI PLAN, VERSION 3.0

Category, Item No., Class	Summary No./ComplD/System	Scope / Method / Procedure	Dwg/ISO No. Comp. Desc. Code Case		Period 1		Period 2			Period 3	
					2VR13	2VR14	2VR14A	2VR15	2VR16	2VR17	2VR18
C-F-1 C5.21 2	V2 21204-057-17 21204-057-17 1204		ISI-21204-057 4" PIPE TO TEE	ISI AUG OWN PRE	-	-	-	-	-	-	-
C-F-1 C5.21 2	V2 21204-057-18 21204-057-18 1204		ISI-21204-057 4" VALVE TO PIPE	ISI AUG OWN PRE	-	-	-	-	-	-	-
C-F-1 C5.21 2	V2 21204-057-19 21204-057-19 1204		ISI-21204-057 4" PIPE TO TEE	ISI AUG OWN PRE	-	-	-	-	-	-	-
C-F-1 C5.21 2	V2 21204-057-2 21204-057-2 1204		ISI-21204-057 3" PIPE TO PIPE	ISI AUG OWN PRE	-	-	-	-	-	-	-
C-F-1 C5.21 2	V2 21204-057-20 21204-057-20 1204		ISI-21204-057 4" TEE TO PIPE	ISI AUG OWN PRE	-	-	-	-	-	-	-
C-F-1 C5.21 2	V2 21204-057-21 21204-057-21 1204		ISI-21204-057 4" PIPE TO PIPE	ISI AUG OWN PRE	-	-	-	-	-	-	-
C-F-1 C5.21 2	V2 21204-057-22 21204-057-22 1204		ISI-21204-057 4" PIPE TO PIPE	ISI AUG OWN PRE	-	-	-	-	-	-	-
C-F-1 C5.21 2	V2 21204-057-23 A 21204-057-23 A 1204		ISI-21204-057 4" PIPE TO PIPE	ISI AUG OWN PRE	-	-	-	-	-	-	-
C-F-1 C5.21 2	V2 21204-057-24 21204-057-24 1204		ISI-21204-057 4" PIPE TO PIPE	ISI AUG OWN PRE	-	-	-	-	-	-	-
C-F-1 C5.21 2	V2 21204-057-25 21204-057-25 1204		ISI-21204-057 4" PIPE TO PIPE	ISI AUG OWN PRE	-	-	-	-	-	-	-

Southern Nuclear Operating Company
3rd Interval
VOGTLE-2 ISI PLAN, VERSION 3.0

Category, Item No., Class	Summary No./ComplD/System	Scope / Method / Procedure	Dwg/ISO No. Comp. Desc. Code Case		Period 1		Period 2			Period 3	
					2VR13	2VR14	2VR14A	2VR15	2VR16	2VR17	2VR18
C-F-1	V2 21204-057-25A		ISI-21204-057	ISI	-	-	-	-	-	-	-
C5.21	21204-057-25A		4" PIPE TO PIPE	AUG	-	-	-	-	-	-	-
2	1204			OWN	-	-	-	-	-	-	-
				PRE	-	-	-	-	-	-	-
C-F-1	V2 21204-057-25B		ISI-21204-057	ISI	-	-	-	-	-	-	-
C5.21	21204-057-25B		4" PIPE TO FLANGE	AUG	-	-	-	-	-	-	-
2	1204			OWN	-	-	-	-	-	-	-
				PRE	-	-	-	-	-	-	-
C-F-1	V2 21204-057-25C		ISI-21204-057	ISI	-	-	-	-	-	-	-
C5.21	21204-057-25C		4" FLANGE TO PIPE	AUG	-	-	-	-	-	-	-
2	1204			OWN	-	-	-	-	-	-	-
				PRE	-	-	-	-	-	-	-
C-F-1	V2 21204-057-25D		ISI-21204-057	ISI	-	-	-	-	-	-	-
C5.21	21204-057-25D		4" PIPE TO FLANGE	AUG	-	-	-	-	-	-	-
2	1204			OWN	-	-	-	-	-	-	-
				PRE	-	-	-	-	-	-	-
C-F-1	V2 21204-057-25E		ISI-21204-057	ISI	-	-	-	-	-	-	-
C5.21	21204-057-25E		4" FLANGE TO PIPE	AUG	-	-	-	-	-	-	-
2	1204			OWN	-	-	-	-	-	-	-
				PRE	-	-	-	-	-	-	-
C-F-1	V2 21204-057-25F		ISI-21204-057	ISI	-	-	-	-	-	-	-
C5.21	21204-057-25F		4" PIPE TO PIPE	AUG	-	-	-	-	-	-	-
2	1204			OWN	-	-	-	-	-	-	-
				PRE	-	-	-	-	-	-	-
C-F-1	V2 21204-057-26		ISI-21204-057	ISI	-	-	-	-	-	-	-
C5.21	21204-057-26		4" PIPE TO ELBOW	AUG	-	-	-	-	-	-	-
2	1204			OWN	-	-	-	-	-	-	-
				PRE	-	-	-	-	-	-	-
C-F-1	V2 21204-057-27		ISI-21204-057	ISI	-	-	-	-	-	-	-
C5.21	21204-057-27		4" ELBOW TO PIPE	AUG	-	-	-	-	-	-	-
2	1204			OWN	-	-	-	-	-	-	-
				PRE	-	-	-	-	-	-	-
C-F-1	V2 21204-057-28		ISI-21204-057	ISI	-	-	-	-	-	-	-
C5.21	21204-057-28		4" PIPE TO ELBOW	AUG	-	-	-	-	-	-	-
2	1204			OWN	-	-	-	-	-	-	-
				PRE	-	-	-	-	-	-	-
C-F-1	V2 21204-057-29		ISI-21204-057	ISI	-	-	-	-	-	-	-
C5.21	21204-057-29		4" ELBOW TO PIPE	AUG	-	-	-	-	-	-	-
2	1204			OWN	-	-	-	-	-	-	-
				PRE	-	-	-	-	-	-	-

Southern Nuclear Operating Company
3rd Interval
VOGTLE-2 ISI PLAN, VERSION 3.0

Category, Item No., Class	Summary No./ComplD/System	Scope / Method / Procedure	Dwg/ISO No. Comp. Desc. Code Case		Period 1		Period 2			Period 3	
					2VR13	2VR14	2VR14A	2VR15	2VR16	2VR17	2VR18
C-F-1 C5.21 2	V2 21204-057-3 21204-057-3 1204		ISI-21204-057 3" PIPE TO PIPE	ISI AUG OWN PRE	-	-	-	-	-	-	-
C-F-1 C5.21 2	V2 21204-057-30 21204-057-30 1204		ISI-21204-057 4" PIPE TO ELBOW	ISI AUG OWN PRE	-	-	-	-	-	-	-
C-F-1 C5.21 2	V2 21204-057-31 21204-057-31 1204		ISI-21204-057 4" ELBOW TO PIPE	ISI AUG OWN PRE	-	-	-	-	-	-	-
C-F-1 C5.21 2	V2 21204-057-32 21204-057-32 1204		ISI-21204-057 4" PIPE TO ELBOW	ISI AUG OWN PRE	-	-	-	-	-	-	-
C-F-1 C5.21 2	V2 21204-057-33 21204-057-33 1204		ISI-21204-057 4" ELBOW TO PIPE	ISI AUG OWN PRE	-	-	-	-	-	-	-
C-F-1 C5.21 2	V2 21204-057-34 21204-057-34 1204		ISI-21204-057 4" PIPE TO ELBOW	ISI AUG OWN PRE	-	-	-	-	-	-	-
C-F-1 C5.21 2	V2 21204-057-35 21204-057-35 1204		ISI-21204-057 4" ELBOW TO PIPE	ISI AUG OWN PRE	-	-	-	-	-	-	-
C-F-1 C5.21 2	V2 21204-057-36 21204-057-36 1204		ISI-21204-057 4" PIPE TO ELBOW	ISI AUG OWN PRE	-	-	-	-	-	-	-
C-F-1 C5.21 2	V2 21204-057-37 21204-057-37 1204		ISI-21204-057 4" ELBOW TO PIPE	ISI AUG OWN PRE	-	-	-	-	-	-	-
C-F-1 C5.21 2	V2 21204-057-39 21204-057-39 1204		ISI-21204-057 4" PIPE TO ELBOW	ISI AUG OWN PRE	-	-	-	-	-	-	-

Southern Nuclear Operating Company
3rd Interval
VOGTLE-2 ISI PLAN, VERSION 3.0

Category, Item No., Class	Summary No./CompID/System	Scope / Method / Procedure	Dwg/ISO No. Comp. Desc. Code Case		Period 1		Period 2			Period 3	
					2VR13	2VR14	2VR14A	2VR15	2VR16	2VR17	2VR18
C-F-1 C5.21 2	V2 21204-057-4 21204-057-4 1204		ISI-21204-057 3" REDUCER TO PIPE	ISI AUG OWN PRE	-	-	-	-	-	-	-
C-F-1 C5.21 2	V2 21204-057-40 21204-057-40 1204		ISI-21204-057 4" ELBOW TO PIPE	ISI AUG OWN PRE	-	-	-	-	-	-	-
C-F-1 C5.21 2	V2 21204-057-41 21204-057-41 1204		ISI-21204-057 4" PIPE TO ELBOW	ISI AUG OWN PRE	-	-	-	-	-	-	-
C-F-1 C5.21 2	V2 21204-057-42 21204-057-42 1204		ISI-21204-057 4" ELBOW TO PIPE	ISI AUG OWN PRE	-	-	-	-	-	-	-
C-F-1 C5.21 2	V2 21204-057-43 21204-057-43 1204		ISI-21204-057 4" PIPE TO PIPE	ISI AUG OWN PRE	-	-	-	-	-	-	-
C-F-1 C5.21 2	V2 21204-057-44 21204-057-44 1204		ISI-21204-057 4" PIPE TO PIPE	ISI AUG OWN PRE	-	-	-	-	-	-	-
C-F-1 C5.21 2	V2 21204-057-45 21204-057-45 1204		ISI-21204-057 4" PIPE TO PIPE	ISI AUG OWN PRE	-	-	-	-	-	-	-
C-F-1 C5.21 2	V2 21204-057-46 21204-057-46 1204		ISI-21204-057 4" PIPE TO ELBOW	ISI AUG OWN PRE	-	-	-	-	-	-	-
C-F-1 C5.21 2	V2 21204-057-47 21204-057-47 1204		ISI-21204-057 4" ELBOW TO PIPE	ISI AUG OWN PRE	-	-	-	-	-	-	-
C-F-1 C5.21 2	V2 21204-057-48 21204-057-48 1204		ISI-21204-057 4" PIPE TO ELBOW	ISI AUG OWN PRE	-	-	-	-	-	-	-

Southern Nuclear Operating Company
3rd Interval
VOGTLE-2 ISI PLAN, VERSION 3.0

Category, Item No., Class	Summary No./CompID/System	Scope / Method / Procedure	Dwg/ISO No. Comp. Desc. Code Case		Period 1		Period 2			Period 3	
					2VR13	2VR14	2VR14A	2VR15	2VR16	2VR17	2VR18
C-F-1 C5.21 2	V2 21204-057-49 21204-057-49 1204	ISI/UT/	ISI-21204-057 4" ELBOW TO PIPE	ISI AUG OWN PRE	-	-	-	-	-	s	-
C-F-1 C5.21 2	V2 21204-057-5 21204-057-5 1204		ISI-21204-057 4" PIPE TO REDUCER	ISI AUG OWN PRE	-	-	-	-	-	-	-
C-F-1 C5.21 2	V2 21204-057-51 21204-057-51 1204		ISI-21204-057 4" PIPE TO PIPE	ISI AUG OWN PRE	-	-	-	-	-	-	-
C-F-1 C5.21 2	V2 21204-057-52 21204-057-52 1204		ISI-21204-057 4" PIPE TO PIPE	ISI AUG OWN PRE	-	-	-	-	-	-	-
C-F-1 C5.21 2	V2 21204-057-52 A 21204-057-52 A 1204		ISI-21204-057 4" PIPE TO PIPE	ISI AUG OWN PRE	-	-	-	-	-	-	-
C-F-1 C5.21 2	V2 21204-057-53 21204-057-53 1204		ISI-21204-057 4" PIPE TO PIPE	ISI AUG OWN PRE	-	-	-	-	-	-	-
C-F-1 C5.21 2	V2 21204-057-54 21204-057-54 1204		ISI-21204-057 4" PIPE TO ELBOW	ISI AUG OWN PRE	-	-	-	-	-	-	-
C-F-1 C5.21 2	V2 21204-057-55 21204-057-55 1204		ISI-21204-057 4" ELBOW TO PIPE	ISI AUG OWN PRE	-	-	-	-	-	-	-
C-F-1 C5.21 2	V2 21204-057-6 21204-057-6 1204	ISI/UT/	ISI-21204-057 4" TEE TO PIPE	ISI AUG OWN PRE	-	-	-	s	-	-	-
C-F-1 C5.21 2	V2 21204-057-7 21204-057-7 1204	ISI/UT/	ISI-21204-057 4" TEE TO PIPE	ISI AUG OWN PRE	-	-	-	s	-	-	-

Southern Nuclear Operating Company
3rd Interval
VOGTLE-2 ISI PLAN, VERSION 3.0

Category, Item No., Class	Summary No./CompID/System	Scope / Method / Procedure	Dwg/ISO No. Comp. Desc. Code Case		Period 1		Period 2		Period 3	
					2VR13	2VR14	2VR14A	2VR15	2VR16	2VR17
C-F-1	V2 21204-057-8		ISI-21204-057	ISI	-	-	-	-	-	-
C5.21	21204-057-8		4" PIPE TO PIPE	AUG	-	-	-	-	-	-
2	1204			OWN	-	-	-	-	-	-
				PRE	-	-	-	-	-	-
C-F-1	V2 21204-063-1		ISI-21204-063	ISI	-	-	-	-	-	-
C5.21	21204-063-1		4" PIPE TO ELBOW	AUG	-	-	-	-	-	-
2	1204			OWN	-	-	-	-	-	-
				PRE	-	-	-	-	-	-
C-F-1	V2 21204-063-10		ISI-21204-063	ISI	-	-	-	-	-	-
C5.21	21204-063-10		4" PIPE TO PIPE	AUG	-	-	-	-	-	-
2	1204			OWN	-	-	-	-	-	-
				PRE	-	-	-	-	-	-
C-F-1	V2 21204-063-10 A		ISI-21204-063	ISI	-	-	-	-	-	-
C5.21	21204-063-10 A		4" PIPE TO FLANGE	AUG	-	-	-	-	-	-
2	1204			OWN	-	-	-	-	-	-
				PRE	-	-	-	-	-	-
C-F-1	V2 21204-063-10 B		ISI-21204-063	ISI	-	-	-	-	-	-
C5.21	21204-063-10 B		4" FLANGE TO PIPE	AUG	-	-	-	-	-	-
2	1204			OWN	-	-	-	-	-	-
				PRE	-	-	-	-	-	-
C-F-1	V2 21204-063-11		ISI-21204-063	ISI	-	-	-	-	-	-
C5.21	21204-063-11		4" PIPE TO TEE	AUG	-	-	-	-	-	-
2	1204			OWN	-	-	-	-	-	-
				PRE	-	-	-	-	-	-
C-F-1	V2 21204-063-12		ISI-21204-063	ISI	-	-	-	-	-	-
C5.21	21204-063-12		4" TEE TO ECC. SWAGE	AUG	-	-	-	-	-	-
2	1204			OWN	-	-	-	-	-	-
				PRE	-	-	-	-	-	-
C-F-1	V2 21204-063-13		ISI-21204-063	ISI	-	-	-	-	-	-
C5.21	21204-063-13		4" TEE TO PIPE	AUG	-	-	-	-	-	-
2	1204			OWN	-	-	-	-	-	-
				PRE	-	-	-	-	-	-
C-F-1	V2 21204-063-14		ISI-21204-063	ISI	-	-	-	-	-	-
C5.21	21204-063-14		4" PIPE TO TEE	AUG	-	-	-	-	-	-
2	1204			OWN	-	-	-	-	-	-
				PRE	-	-	-	-	-	-
C-F-1	V2 21204-063-15		ISI-21204-063	ISI	-	-	-	-	-	-
C5.21	21204-063-15		4" TEE TO PIPE	AUG	-	-	-	-	-	-
2	1204			OWN	-	-	-	-	-	-
				PRE	-	-	-	-	-	-

Southern Nuclear Operating Company
3rd Interval
VOGTLE-2 ISI PLAN, VERSION 3.0

Category, Item No., Class	Summary No./ComplID/System	Scope / Method / Procedure	Dwg/ISO No. Comp. Desc. Code Case		Period 1		Period 2			Period 3	
					2VR13	2VR14	2VR14A	2VR15	2VR16	2VR17	2VR18
C-F-1 C5.21 2	V2 21204-063-17 21204-063-17 1204		ISI-21204-063 4" PIPE TO ELBOW	ISI AUG OWN PRE	-	-	-	-	-	-	-
C-F-1 C5.21 2	V2 21204-063-18 21204-063-18 1204	ISI/UT/	ISI-21204-063 4" ELBOW TO PIPE	ISI AUG OWN PRE	-	-	-	-	-	s	-
C-F-1 C5.21 2	V2 21204-063-19 21204-063-19 1204		ISI-21204-063 4" PIPE TO VALVE	ISI AUG OWN PRE	-	-	-	-	-	-	-
C-F-1 C5.21 2	V2 21204-063-2 21204-063-2 1204		ISI-21204-063 4" ELBOW TO PIPE	ISI AUG OWN PRE	-	-	-	-	-	-	-
C-F-1 C5.21 2	V2 21204-063-20 21204-063-20 1204		ISI-21204-063 4" VALVE TO PIPE	ISI AUG OWN PRE	-	-	-	-	-	-	-
C-F-1 C5.21 2	V2 21204-063-21 21204-063-21 1204	ISI/UT/	ISI-21204-063 4" PIPE TO REDUCER	ISI AUG OWN PRE	-	-	-	-	-	s	-
C-F-1 C5.21 2	V2 21204-063-22 21204-063-22 1204		ISI-21204-063 3" REDUCER TO PIPE	ISI AUG OWN PRE	-	-	-	-	-	-	-
C-F-1 C5.21 2	V2 21204-063-23 21204-063-23 1204		ISI-21204-063 3" PIPE TO ELBOW	ISI AUG OWN PRE	-	-	-	-	-	-	-
C-F-1 C5.21 2	V2 21204-063-24 21204-063-24 1204		ISI-21204-063 3" ELBOW TO PIPE	ISI AUG OWN PRE	-	-	-	-	-	-	-
C-F-1 C5.21 2	V2 21204-063-25 21204-063-25 1204		ISI-21204-063 3" PIPE TO PIPE	ISI AUG OWN PRE	-	-	-	-	-	-	-

Southern Nuclear Operating Company
3rd Interval
VOGTLE-2 ISI PLAN, VERSION 3.0

Category, Item No., Class	Summary No./ComplD/System	Scope / Method / Procedure	Dwg/ISO No. Comp. Desc. Code Case		Period 1		Period 2			Period 3	
					2VR13	2VR14	2VR14A	2VR15	2VR16	2VR17	2VR18
C-F-1 C5.21 2	V2 21204-063-26 21204-063-26 1204		ISI-21204-063 4" TEE TO PIPE	ISI AUG OWN PRE	- - - -	- - - -	- - - -	- - - -	- - - -	- - - -	- - - -
C-F-1 C5.21 2	V2 21204-063-27 21204-063-27 1204		ISI-21204-063 4" PIPE TO VALVE	ISI AUG OWN PRE	- - - -	- - - -	- - - -	- - - -	- - - -	- - - -	- - - -
C-F-1 C5.21 2	V2 21204-063-28 21204-063-28 1204		ISI-21204-063 4" VALVE TO PIPE	ISI AUG OWN PRE	- - - -	- - - -	- - - -	- - - -	- - - -	- - - -	- - - -
C-F-1 C5.21 2	V2 21204-063-29 21204-063-29 1204		ISI-21204-063 4" PIPE TO REDUCER	ISI AUG OWN PRE	- - - -	- - - -	- - - -	- - - -	- - - -	- - - -	- - - -
C-F-1 C5.21 2	V2 21204-063-3 21204-063-3 1204		ISI-21204-063 4" PIPE TO PIPE	ISI AUG OWN PRE	- - - -	- - - -	- - - -	- - - -	- - - -	- - - -	- - - -
C-F-1 C5.21 2	V2 21204-063-30 21204-063-30 1204		ISI-21204-063 3" REDUCER TO PIPE	ISI AUG OWN PRE	- - - -	- - - -	- - - -	- - - -	- - - -	- - - -	- - - -
C-F-1 C5.21 2	V2 21204-063-31 21204-063-31 1204		ISI-21204-063 3" PIPE TO ELBOW	ISI AUG OWN PRE	- - - -	- - - -	- - - -	- - - -	- - - -	- - - -	- - - -
C-F-1 C5.21 2	V2 21204-063-32 21204-063-32 1204		ISI-21204-063 3" ELBOW TO PIPE	ISI AUG OWN PRE	- - - -	- - - -	- - - -	- - - -	- - - -	- - - -	- - - -
C-F-1 C5.21 2	V2 21204-063-33 21204-063-33 1204		ISI-21204-063 3" PIPE TO TEE	ISI AUG OWN PRE	- - - -	- - - -	- - - -	- - - -	- - - -	- - - -	- - - -
C-F-1 C5.21 2	V2 21204-063-34 21204-063-34 1204		ISI-21204-063 3" TEE TO PIPE	ISI AUG OWN PRE	- - - -	- - - -	- - - -	- - - -	- - - -	- - - -	- - - -

Southern Nuclear Operating Company
3rd Interval
VOGTLE-2 ISI PLAN, VERSION 3.0

Category, Item No., Class	Summary No./ComplD/System	Scope / Method / Procedure	Dwg/ISO No. Comp. Desc. Code Case		Period 1		Period 2			Period 3	
					2VR13	2VR14	2VR14A	2VR15	2VR16	2VR17	2VR18
C-F-1 C5.21 2	V2 21204-063-35 21204-063-35 1204		ISI-21204-063 3" PIPE TO ELBOW	ISI AUG OWN PRE	-	-	-	-	-	-	-
C-F-1 C5.21 2	V2 21204-063-36 21204-063-36 1204		ISI-21204-063 3" ELBOW TO PIPE	ISI AUG OWN PRE	-	-	-	-	-	-	-
C-F-1 C5.21 2	V2 21204-063-37 21204-063-37 1204		ISI-21204-063 3" PIPE TO ELBOW (AI 87-0131)	ISI AUG OWN PRE	-	-	-	-	-	-	-
C-F-1 C5.21 2	V2 21204-063-38 21204-063-38 1204		ISI-21204-063 3" ELBOW TO PIPE (AI 87-0131)	ISI AUG OWN PRE	-	-	-	-	-	-	-
C-F-1 C5.21 2	V2 21204-063-39 21204-063-39 1204		ISI-21204-063 3" PIPE TO PENETRATION PROCESS PIPE (AI 87-0131)	ISI AUG OWN PRE	-	-	-	-	-	-	-
C-F-1 C5.21 2	V2 21204-063-4 21204-063-4 1204		ISI-21204-063 4" PIPE TO PIPE	ISI AUG OWN PRE	-	-	-	-	-	-	-
C-F-1 C5.21 2	V2 21204-063-4 A 21204-063-4 A 1204		ISI-21204-063 4" PIPE TO PIPE	ISI AUG OWN PRE	-	-	-	-	-	-	-
C-F-1 C5.21 2	V2 21204-063-40 21204-063-40 1204		ISI-21204-063 3" PENETRATION PROCESS PIPE TO FLUED HEAD	ISI AUG OWN PRE	-	-	-	-	-	-	-
C-F-1 C5.21 2	V2 21204-063-41 21204-063-41 1204		ISI-21204-063 3" FLUED HEAD PIPE	ISI AUG OWN PRE	-	-	-	-	-	-	-
C-F-1 C5.21	V2 21204-063-42 21204-063-42	ISI/UT/	ISI-21204-063 3" PIPE TO ELBOW (AI 87-0131)	ISI AUG	-	-	-	-	s	-	-

Southern Nuclear Operating Company
3rd Interval
VOGTLE-2 ISI PLAN, VERSION 3.0

Category, Item No., Class	Summary No./CompID/System	Scope / Method / Procedure	Dwg/ISO No. Comp. Desc. Code Case		Period 1		Period 2			Period 3	
					2VR13	2VR14	2VR14A	2VR15	2VR16	2VR17	2VR18
2	1204			OWN PRE	-	-	-	-	-	-	-
C-F-1	V2 21204-063-43	ISI/UT/	ISI-21204-063	ISI	-	-	-	-	-	-	-
C5.21	21204-063-43		3" ELBOW TO PIPE (AI 87-0131)	AUG	-	-	-	-	-	-	-
2	1204			OWN PRE	-	-	-	-	-	-	-
C-F-1	V2 21204-063-44		ISI-21204-063	ISI	-	-	-	-	-	-	-
C5.21	21204-063-44		3" PIPE TO ELBOW	AUG	-	-	-	-	-	-	-
2	1204			OWN PRE	-	-	-	-	-	-	-
C-F-1	V2 21204-063-45		ISI-21204-063	ISI	-	-	-	-	-	-	-
C5.21	21204-063-45		3" ELBOW TO PIPE	AUG	-	-	-	-	-	-	-
2	1204			OWN PRE	-	-	-	-	-	-	-
C-F-1	V2 21204-063-46		ISI-21204-063	ISI	-	-	-	-	-	-	-
C5.21	21204-063-46		3" PIPE TO VALVE	AUG	-	-	-	-	-	-	-
2	1204			OWN PRE	-	-	-	-	-	-	-
C-F-1	V2 21204-063-5		ISI-21204-063	ISI	-	-	-	-	-	-	-
C5.21	21204-063-5		4" PIPE TO ELBOW	AUG	-	-	-	-	-	-	-
2	1204			OWN PRE	-	-	-	-	-	-	-
C-F-1	V2 21204-063-6		ISI-21204-063	ISI	-	-	-	-	-	-	-
C5.21	21204-063-6		4" ELBOW TO PIPE	AUG	-	-	-	-	-	-	-
2	1204			OWN PRE	-	-	-	-	-	-	-
C-F-1	V2 21204-063-7		ISI-21204-063	ISI	-	-	-	-	-	-	-
C5.21	21204-063-7		4" PIPE TO ELBOW	AUG	-	-	-	-	-	-	-
2	1204			OWN PRE	-	-	-	-	-	-	-
C-F-1	V2 21204-063-8		ISI-21204-063	ISI	-	-	-	-	-	-	-
C5.21	21204-063-8		4" ELBOW TO PIPE	AUG	-	-	-	-	-	-	-
2	1204			OWN PRE	-	-	-	-	-	-	-
C-F-1	V2 21208-003-1		ISI-21208-003	ISI	-	-	-	-	-	-	-
C5.21	21208-003-1		3" VALVE TO PIPE	AUG	-	-	-	-	-	-	-
2	1208			OWN PRE	-	-	-	-	-	-	-
C-F-1	V2 21208-003-10		ISI-21208-003	ISI	-	-	-	-	-	-	-
C5.21	21208-003-10		3" VALVE TO PIPE	AUG	-	-	-	-	-	-	-

Southern Nuclear Operating Company
3rd Interval
VOGTLE-2 ISI PLAN, VERSION 3.0

Category, Item No., Class	Summary No./CompID/System	Scope / Method / Procedure	Dwg/ISO No. Comp. Desc. Code Case		Period 1		Period 2		Period 3	
					2VR13	2VR14	2VR14A	2VR15	2VR16	2VR17
	1208			OWN	-	-	-	-	-	-
				PRE	-	-	-	-	-	-
C-F-1	V2 21208-003-101		ISI-21208-003	ISI	-	-	-	-	-	-
C5.21	21208-003-101		3" PIPE TO ELBOW	AUG	-	-	-	-	-	-
2	1208			OWN	-	-	-	-	-	-
				PRE	-	-	-	-	-	-
C-F-1	V2 21208-003-102		ISI-21208-003	ISI	-	-	-	-	-	-
C5.21	21208-003-102		3" ELBOW TO PIPE	AUG	-	-	-	-	-	-
2	1208			OWN	-	-	-	-	-	-
				PRE	-	-	-	-	-	-
C-F-1	V2 21208-003-103		ISI-21208-003	ISI	-	-	-	-	-	-
C5.21	21208-003-103		3" PIPE TO ELBOW	AUG	-	-	-	-	-	-
2	1208			OWN	-	-	-	-	-	-
				PRE	-	-	-	-	-	-
C-F-1	V2 21208-003-104		ISI-21208-003	ISI	-	-	-	-	-	-
C5.21	21208-003-104		3" ELBOW TO PIPE	AUG	-	-	-	-	-	-
2	1208			OWN	-	-	-	-	-	-
				PRE	-	-	-	-	-	-
C-F-1	V2 21208-003-105		ISI-21208-003	ISI	-	-	-	-	-	-
C5.21	21208-003-105		3" PIPE TO VALVE	AUG	-	-	-	-	-	-
2	1208			OWN	-	-	-	-	-	-
				PRE	-	-	-	-	-	-
C-F-1	V2 21208-003-11		ISI-21208-003	ISI	-	-	-	-	-	-
C5.21	21208-003-11		3" PIPE TO TEE	AUG	-	-	-	-	-	-
2	1208			OWN	-	-	-	-	-	-
				PRE	-	-	-	-	-	-
C-F-1	V2 21208-003-11A		ISI-21208-003	ISI	-	-	-	-	-	-
C5.21	21208-003-11A		3" PIPE TO PIPE	AUG	-	-	-	-	-	-
2	1208			OWN	-	-	-	-	-	-
				PRE	-	-	-	-	-	-
C-F-1	V2 21208-003-12		ISI-21208-003	ISI	-	-	-	-	-	-
C5.21	21208-003-12		3" TEE TO PIPE	AUG	-	-	-	-	-	-
2	1208			OWN	-	-	-	-	-	-
				PRE	-	-	-	-	-	-
C-F-1	V2 21208-003-12A		ISI-21208-003	ISI	-	-	-	-	-	-
C5.21	21208-003-12A		3" PIPE TO ELBOW	AUG	-	-	-	-	-	-
2	1208			OWN	-	-	-	-	-	-
				PRE	-	-	-	-	-	-
C-F-1	V2 21208-003-13A		ISI-21208-003	ISI	-	-	-	-	-	-
C5.21	21208-003-13A		3" ELBOW TO PIPE	AUG	-	-	-	-	-	-

Southern Nuclear Operating Company
3rd Interval
VOGTLE-2 ISI PLAN, VERSION 3.0

Category, Item No., Class	Summary No./CompID/System 1208	Scope / Method / Procedure	Dwg/ISO No. Comp. Desc. Code Case		Period 1		Period 2			Period 3	
					2VR13	2VR14	2VR14A	2VR15	2VR16	2VR17	2VR18
				OWN	-	-	-	-	-	-	-
				PRE	-	-	-	-	-	-	-
C-F-1	V2 21208-003-14		ISI-21208-003	ISI	-	-	-	-	-	-	-
C5.21	21208-003-14		3" PIPE TO PIPE	AUG	-	-	-	-	-	-	-
2	1208			OWN	-	-	-	-	-	-	-
				PRE	-	-	-	-	-	-	-
C-F-1	V2 21208-003-14A		ISI-21208-003	ISI	-	-	-	-	-	-	-
C5.21	21208-003-14A		3" PIPE TO ELBOW	AUG	-	-	-	-	-	-	-
2	1208			OWN	-	-	-	-	-	-	-
				PRE	-	-	-	-	-	-	-
C-F-1	V2 21208-003-14B		ISI-21208-003	ISI	-	-	-	-	-	-	-
C5.21	21208-003-14B		3" ELBOW TO PIPE	AUG	-	-	-	-	-	-	-
2	1208			OWN	-	-	-	-	-	-	-
				PRE	-	-	-	-	-	-	-
C-F-1	V2 21208-003-15		ISI-21208-003	ISI	-	-	-	-	-	-	-
C5.21	21208-003-15		3" PIPE TO PIPE	AUG	-	-	-	-	-	-	-
2	1208			OWN	-	-	-	-	-	-	-
				PRE	-	-	-	-	-	-	-
C-F-1	V2 21208-003-16		ISI-21208-003	ISI	-	-	-	-	-	-	-
C5.21	21208-003-16		3" PIPE TO FLANGE	AUG	-	-	-	-	-	-	-
2	1208			OWN	-	-	-	-	-	-	-
				PRE	-	-	-	-	-	-	-
C-F-1	V2 21208-003-17		ISI-21208-003	ISI	-	-	-	-	-	-	-
C5.21	21208-003-17		3" FLANGE TO PIPE	AUG	-	-	-	-	-	-	-
2	1208			OWN	-	-	-	-	-	-	-
				PRE	-	-	-	-	-	-	-
C-F-1	V2 21208-003-19		ISI-21208-003	ISI	-	-	-	-	-	-	-
C5.21	21208-003-19		3" PIPE TO TEE	AUG	-	-	-	-	-	-	-
2	1208			OWN	-	-	-	-	-	-	-
				PRE	-	-	-	-	-	-	-
C-F-1	V2 21208-003-2		ISI-21208-003	ISI	-	-	-	-	-	-	-
C5.21	21208-003-2		3" PIPE TO VALVE	AUG	-	-	-	-	-	-	-
2	1208			OWN	-	-	-	-	-	-	-
				PRE	-	-	-	-	-	-	-
C-F-1	V2 21208-003-20		ISI-21208-003	ISI	-	-	-	-	-	-	-
C5.21	21208-003-20		3" TEE TO PIPE	AUG	-	-	-	-	-	-	-
2	1208			OWN	-	-	-	-	-	-	-
				PRE	-	-	-	-	-	-	-
C-F-1	V2 21208-003-22		ISI-21208-003	ISI	-	-	-	-	-	-	-
C5.21	21208-003-22		3" PIPE TO VALVE	AUG	-	-	-	-	-	-	-

Southern Nuclear Operating Company
3rd Interval
VOGTLE-2 ISI PLAN, VERSION 3.0

Category, Item No., Class	Summary No./CompID/System	Scope / Method / Procedure	Dwg/ISO No. Comp. Desc. Code Case		Period 1		Period 2			Period 3	
					2VR13	2VR14	2VR14A	2VR15	2VR16	2VR17	2VR18
2	1208			OWN	-	-	-	-	-	-	-
				PRE	-	-	-	-	-	-	-
C-F-1	V2 21208-003-23		ISI-21208-003	ISI	-	-	-	-	-	-	-
C5.21	21208-003-23		3" VALVE TO PIPE	AUG	-	-	-	-	-	-	-
2	1208			OWN	-	-	-	-	-	-	-
				PRE	-	-	-	-	-	-	-
C-F-1	V2 21208-003-24		ISI-21208-003	ISI	-	-	-	-	-	-	-
C5.21	21208-003-24		3" PIPE TO VALVE	AUG	-	-	-	-	-	-	-
2	1208			OWN	-	-	-	-	-	-	-
				PRE	-	-	-	-	-	-	-
C-F-1	V2 21208-003-25		ISI-21208-003	ISI	-	-	-	-	-	-	-
C5.21	21208-003-25		3" VALVE TO PIPE	AUG	-	-	-	-	-	-	-
2	1208			OWN	-	-	-	-	-	-	-
				PRE	-	-	-	-	-	-	-
C-F-1	V2 21208-003-26		ISI-21208-003	ISI	-	-	-	-	-	-	-
C5.21	21208-003-26		3" PIPE TO VALVE	AUG	-	-	-	-	-	-	-
2	1208			OWN	-	-	-	-	-	-	-
				PRE	-	-	-	-	-	-	-
C-F-1	V2 21208-003-27		ISI-21208-003	ISI	-	-	-	-	-	-	-
C5.21	21208-003-27		3" VALVE TO PIPE	AUG	-	-	-	-	-	-	-
2	1208			OWN	-	-	-	-	-	-	-
				PRE	-	-	-	-	-	-	-
C-F-1	V2 21208-003-28		ISI-21208-003	ISI	-	-	-	-	-	-	-
C5.21	21208-003-28		3" PIPE TO TEE	AUG	-	-	-	-	-	-	-
2	1208			OWN	-	-	-	-	-	-	-
				PRE	-	-	-	-	-	-	-
C-F-1	V2 21208-003-29	ISI/UT/	ISI-21208-003	ISI	-	-	-	-	-	s	-
C5.21	21208-003-29		3" TEE TO PIPE	AUG	-	-	-	-	-	-	-
2	1208			OWN	-	-	-	-	-	-	-
				PRE	-	-	-	-	-	-	-
C-F-1	V2 21208-003-3		ISI-21208-003	ISI	-	-	-	-	-	-	-
C5.21	21208-003-3		3" VALVE TO PIPE	AUG	-	-	-	-	-	-	-
2	1208			OWN	-	-	-	-	-	-	-
				PRE	-	-	-	-	-	-	-
C-F-1	V2 21208-003-30		ISI-21208-003	ISI	-	-	-	-	-	-	-
C5.21	21208-003-30		3" PIPE TO VALVE	AUG	-	-	-	-	-	-	-
2	1208			OWN	-	-	-	-	-	-	-
				PRE	-	-	-	-	-	-	-
C-F-1	V2 21208-003-31		ISI-21208-003	ISI	-	-	-	-	-	-	-
C5.21	21208-003-31		3" VALVE TO PIPE	AUG	-	-	-	-	-	-	-

Southern Nuclear Operating Company
3rd Interval
VOGTLE-2 ISI PLAN, VERSION 3.0

Category, Item No., Class	Summary No./ComplID/System	Scope / Method / Procedure	Dwg/ISO No. Comp. Desc. Code Case		Period 1		Period 2		Period 3	
					2VR13	2VR14	2VR14A	2VR15	2VR16	2VR17
2	1208			OWN	-	-	-	-	-	-
				PRE	-	-	-	-	-	-
C-F-1	V2 21208-003-32	ISI/UT/	ISI-21208-003	ISI	-	-	-	-	-	s
C5.21	21208-003-32		3" PIPE TO TEE	AUG	-	-	-	-	-	-
2	1208			OWN	-	-	-	-	-	-
				PRE	-	-	-	-	-	-
C-F-1	V2 21208-003-33		ISI-21208-003	ISI	-	-	-	-	-	-
C5.21	21208-003-33		3" TEE TO PIPE	AUG	-	-	-	-	-	-
2	1208			OWN	-	-	-	-	-	-
				PRE	-	-	-	-	-	-
C-F-1	V2 21208-003-34		ISI-21208-003	ISI	-	-	-	-	-	-
C5.21	21208-003-34		3" PIPE TO PIPE	AUG	-	-	-	-	-	-
2	1208			OWN	-	-	-	-	-	-
				PRE	-	-	-	-	-	-
C-F-1	V2 21208-003-35		ISI-21208-003	ISI	-	-	-	-	-	-
C5.21	21208-003-35		3" PIPE TO PIPE	AUG	-	-	-	-	-	-
2	1208			OWN	-	-	-	-	-	-
				PRE	-	-	-	-	-	-
C-F-1	V2 21208-003-36		ISI-21208-003	ISI	-	-	-	-	-	-
C5.21	21208-003-36		3" PIPE TO ELBOW	AUG	-	-	-	-	-	-
2	1208			OWN	-	-	-	-	-	-
				PRE	-	-	-	-	-	-
C-F-1	V2 21208-003-37		ISI-21208-003	ISI	-	-	-	-	-	-
C5.21	21208-003-37		3" ELBOW TO PIPE	AUG	-	-	-	-	-	-
2	1208			OWN	-	-	-	-	-	-
				PRE	-	-	-	-	-	-
C-F-1	V2 21208-003-38		ISI-21208-003	ISI	-	-	-	-	-	-
C5.21	21208-003-38		3" PIPE TO ELBOW	AUG	-	-	-	-	-	-
2	1208			OWN	-	-	-	-	-	-
				PRE	-	-	-	-	-	-
C-F-1	V2 21208-003-39		ISI-21208-003	ISI	-	-	-	-	-	-
C5.21	21208-003-39		3" ELBOW TO PIPE	AUG	-	-	-	-	-	-
2	1208			OWN	-	-	-	-	-	-
				PRE	-	-	-	-	-	-
C-F-1	V2 21208-003-39 A		ISI-21208-003	ISI	-	-	-	-	-	-
C5.21	21208-003-39 A		3" PIPE TO PIPE	AUG	-	-	-	-	-	-
2	1208			OWN	-	-	-	-	-	-
				PRE	-	-	-	-	-	-
C-F-1	V2 21208-003-4		ISI-21208-003	ISI	-	-	-	-	-	-
C5.21	21208-003-4		3" PIPE TO TEE	AUG	-	-	-	-	-	-

Southern Nuclear Operating Company
3rd Interval
VOGTLE-2 ISI PLAN, VERSION 3.0

Category, Item No., Class	Summary No./CompID/System	Scope / Method / Procedure	Dwg/ISO No. Comp. Desc. Code Case		Period 1		Period 2		Period 3	
					2VR13	2VR14	2VR14A	2VR15	2VR16	2VR17
	1208			OWN	-	-	-	-	-	-
				PRE	-	-	-	-	-	-
C-F-1	V2 21208-003-41		ISI-21208-003	ISI	-	-	-	-	-	-
C5.21	21208-003-41		3" PIPE TO PIPE	AUG	-	-	-	-	-	-
2	1208			OWN	-	-	-	-	-	-
				PRE	-	-	-	-	-	-
C-F-1	V2 21208-003-42		ISI-21208-003	ISI	-	-	-	-	-	-
C5.21	21208-003-42		3" PIPE TO ELBOW (AI 87-0131)	AUG	-	-	-	-	-	-
2	1208			OWN	-	-	-	-	-	-
				PRE	-	-	-	-	-	-
C-F-1	V2 21208-003-43		ISI-21208-003	ISI	-	-	-	-	-	-
C5.21	21208-003-43		3" ELBOW TO PIPE (AI 87-0131)	AUG	-	-	-	-	-	-
2	1208			OWN	-	-	-	-	-	-
				PRE	-	-	-	-	-	-
C-F-1	V2 21208-003-45		ISI-21208-003	ISI	-	-	-	-	-	-
C5.21	21208-003-45		3" PIPE TO ELBOW	AUG	-	-	-	-	-	-
2	1208			OWN	-	-	-	-	-	-
				PRE	-	-	-	-	-	-
C-F-1	V2 21208-003-46		ISI-21208-003	ISI	-	-	-	-	-	-
C5.21	21208-003-46		3" ELBOW TO PIPE	AUG	-	-	-	-	-	-
2	1208			OWN	-	-	-	-	-	-
				PRE	-	-	-	-	-	-
C-F-1	V2 21208-003-47		ISI-21208-003	ISI	-	-	-	-	-	-
C5.21	21208-003-47		3" PIPE TO ELBOW	AUG	-	-	-	-	-	-
2	1208			OWN	-	-	-	-	-	-
				PRE	-	-	-	-	-	-
C-F-1	V2 21208-003-48		ISI-21208-003	ISI	-	-	-	-	-	-
C5.21	21208-003-48		3" ELBOW TO PIPE	AUG	-	-	-	-	-	-
2	1208			OWN	-	-	-	-	-	-
				PRE	-	-	-	-	-	-
C-F-1	V2 21208-003-49		ISI-21208-003	ISI	-	-	-	-	-	-
C5.21	21208-003-49		3" PIPE TO ELBOW	AUG	-	-	-	-	-	-
2	1208			OWN	-	-	-	-	-	-
				PRE	-	-	-	-	-	-
C-F-1	V2 21208-003-4A		ISI-21208-003	ISI	-	-	-	-	-	-
C5.21	21208-003-4A		3" PIPE TO PIPE	AUG	-	-	-	-	-	-
2	1208			OWN	-	-	-	-	-	-
				PRE	-	-	-	-	-	-
C-F-1	V2 21208-003-4B		ISI-21208-003	ISI	-	-	-	-	-	-
C5.21	21208-003-4B		3" PIPE TO ELBOW (AI 87-0131)	AUG	-	-	-	-	-	-

Southern Nuclear Operating Company
3rd Interval
VOGTLE-2 ISI PLAN, VERSION 3.0

Category, Item No., Class	Summary No./CompID/System 1208	Scope / Method / Procedure	Dwg/ISO No. Comp. Desc. Code Case		Period 1		Period 2			Period 3	
					2VR13	2VR14	2VR14A	2VR15	2VR16	2VR17	2VR18
				OWN	-	-	-	-	-	-	-
				PRE	-	-	-	-	-	-	-
C-F-1	V2 21208-003-4C		ISI-21208-003	ISI	-	-	-	-	-	-	-
C5.21	21208-003-4C		3" ELBOW TO PIPE (AI 87-0131)	AUG	-	-	-	-	-	-	-
2	1208			OWN	-	-	-	-	-	-	-
				PRE	-	-	-	-	-	-	-
C-F-1	V2 21208-003-4D		ISI-21208-003	ISI	-	-	-	-	-	-	-
C5.21	21208-003-4D		3" PIPE TO ELBOW	AUG	-	-	-	-	-	-	-
2	1208			OWN	-	-	-	-	-	-	-
				PRE	-	-	-	-	-	-	-
C-F-1	V2 21208-003-4E		ISI-21208-003	ISI	-	-	-	-	-	-	-
C5.21	21208-003-4E		3" ELBOW TO PIPE	AUG	-	-	-	-	-	-	-
2	1208			OWN	-	-	-	-	-	-	-
				PRE	-	-	-	-	-	-	-
C-F-1	V2 21208-003-4F		ISI-21208-003	ISI	-	-	-	-	-	-	-
C5.21	21208-003-4F		3" PIPE TO ELBOW	AUG	-	-	-	-	-	-	-
2	1208			OWN	-	-	-	-	-	-	-
				PRE	-	-	-	-	-	-	-
C-F-1	V2 21208-003-4G		ISI-21208-003	ISI	-	-	-	-	-	-	-
C5.21	21208-003-4G		3" ELBOW TO PIPE	AUG	-	-	-	-	-	-	-
2	1208			OWN	-	-	-	-	-	-	-
				PRE	-	-	-	-	-	-	-
C-F-1	V2 21208-003-4H	ISI/UT/	ISI-21208-003	ISI	-	-	-	-	-	s	-
C5.21	21208-003-4H		3" PIPE TO TEE	AUG	-	-	-	-	-	-	-
2	1208			OWN	-	-	-	-	-	-	-
				PRE	-	-	-	-	-	-	-
C-F-1	V2 21208-003-5		ISI-21208-003	ISI	-	-	-	-	-	-	-
C5.21	21208-003-5		3" VALVE TO PIPE	AUG	-	-	-	-	-	-	-
2	1208			OWN	-	-	-	-	-	-	-
				PRE	-	-	-	-	-	-	-
C-F-1	V2 21208-003-50		ISI-21208-003	ISI	-	-	-	-	-	-	-
C5.21	21208-003-50		3" ELBOW TO PIPE	AUG	-	-	-	-	-	-	-
2	1208			OWN	-	-	-	-	-	-	-
				PRE	-	-	-	-	-	-	-
C-F-1	V2 21208-003-51		ISI-21208-003	ISI	-	-	-	-	-	-	-
C5.21	21208-003-51		3" PIPE TO ELBOW	AUG	-	-	-	-	-	-	-
2	1208			OWN	-	-	-	-	-	-	-
				PRE	-	-	-	-	-	-	-
C-F-1	V2 21208-003-52		ISI-21208-003	ISI	-	-	-	-	-	-	-
C5.21	21208-003-52		3" ELBOW TO PIPE	AUG	-	-	-	-	-	-	-

Southern Nuclear Operating Company
3rd Interval
VOGTLE-2 ISI PLAN, VERSION 3.0

Category, Item No., Class	Summary No./CompID/System	Scope / Method / Procedure	Dwg/ISO No. Comp. Desc. Code Case		Period 1		Period 2			Period 3	
					2VR13	2VR14	2VR14A	2VR15	2VR16	2VR17	2VR18
2	1208			OWN	-	-	-	-	-	-	-
				PRE	-	-	-	-	-	-	-
C-F-1	V2 21208-003-53		ISI-21208-003	ISI	-	-	-	-	-	-	-
C5.21	21208-003-53		3" PIPE TO ELBOW	AUG	-	-	-	-	-	-	-
2	1208			OWN	-	-	-	-	-	-	-
				PRE	-	-	-	-	-	-	-
C-F-1	V2 21208-003-54		ISI-21208-003	ISI	-	-	-	-	-	-	-
C5.21	21208-003-54		3" ELBOW TO PIPE	AUG	-	-	-	-	-	-	-
2	1208			OWN	-	-	-	-	-	-	-
				PRE	-	-	-	-	-	-	-
C-F-1	V2 21208-003-56		ISI-21208-003	ISI	-	-	-	-	-	-	-
C5.21	21208-003-56		3" PIPE TO PIPE	AUG	-	-	-	-	-	-	-
2	1208			OWN	-	-	-	-	-	-	-
				PRE	-	-	-	-	-	-	-
C-F-1	V2 21208-003-57		ISI-21208-003	ISI	-	-	-	-	-	-	-
C5.21	21208-003-57		3" PIPE TO ELBOW	AUG	-	-	-	-	-	-	-
2	1208			OWN	-	-	-	-	-	-	-
				PRE	-	-	-	-	-	-	-
C-F-1	V2 21208-003-58		ISI-21208-003	ISI	-	-	-	-	-	-	-
C5.21	21208-003-58		3" ELBOW TO PIPE	AUG	-	-	-	-	-	-	-
2	1208			OWN	-	-	-	-	-	-	-
				PRE	-	-	-	-	-	-	-
C-F-1	V2 21208-003-59		ISI-21208-003	ISI	-	-	-	-	-	-	-
C5.21	21208-003-59		3" PIPE TO ELBOW	AUG	-	-	-	-	-	-	-
2	1208			OWN	-	-	-	-	-	-	-
				PRE	-	-	-	-	-	-	-
C-F-1	V2 21208-003-60		ISI-21208-003	ISI	-	-	-	-	-	-	-
C5.21	21208-003-60		3" ELBOW TO ELBOW	AUG	-	-	-	-	-	-	-
2	1208			OWN	-	-	-	-	-	-	-
				PRE	-	-	-	-	-	-	-
C-F-1	V2 21208-003-61		ISI-21208-003	ISI	-	-	-	-	-	-	-
C5.21	21208-003-61		3" ELBOW TO PIPE	AUG	-	-	-	-	-	-	-
2	1208			OWN	-	-	-	-	-	-	-
				PRE	-	-	-	-	-	-	-
C-F-1	V2 21208-003-62		ISI-21208-003	ISI	-	-	-	-	-	-	-
C5.21	21208-003-62		3" PIPE TO PIPE	AUG	-	-	-	-	-	-	-
2	1208			OWN	-	-	-	-	-	-	-
				PRE	-	-	-	-	-	-	-
C-F-1	V2 21208-003-63		ISI-21208-003	ISI	-	-	-	-	-	-	-
C5.21	21208-003-63		3" PIPE TO PIPE	AUG	-	-	-	-	-	-	-

Southern Nuclear Operating Company
3rd Interval
VOGTLE-2 ISI PLAN, VERSION 3.0

Category, Item No., Class	Summary No./CompID/System	Scope / Method / Procedure	Dwg/ISO No. Comp. Desc. Code Case		Period 1		Period 2			Period 3	
					2VR13	2VR14	2VR14A	2VR15	2VR16	2VR17	2VR18
2	1208			OWN	-	-	-	-	-	-	-
				PRE	-	-	-	-	-	-	-
C-F-1	V2 21208-003-65		ISI-21208-003	ISI	-	-	-	-	-	-	-
C5.21	21208-003-65		3" PIPE TO ELBOW	AUG	-	-	-	-	-	-	-
2	1208			OWN	-	-	-	-	-	-	-
				PRE	-	-	-	-	-	-	-
C-F-1	V2 21208-003-66		ISI-21208-003	ISI	-	-	-	-	-	-	-
C5.21	21208-003-66		3" ELBOW TO PIPE	AUG	-	-	-	-	-	-	-
2	1208			OWN	-	-	-	-	-	-	-
				PRE	-	-	-	-	-	-	-
C-F-1	V2 21208-003-67		ISI-21208-003	ISI	-	-	-	-	-	-	-
C5.21	21208-003-67		3" PIPE TO ELBOW	AUG	-	-	-	-	-	-	-
2	1208			OWN	-	-	-	-	-	-	-
				PRE	-	-	-	-	-	-	-
C-F-1	V2 21208-003-68		ISI-21208-003	ISI	-	-	-	-	-	-	-
C5.21	21208-003-68		3" ELBOW TO PIPE	AUG	-	-	-	-	-	-	-
2	1208			OWN	-	-	-	-	-	-	-
				PRE	-	-	-	-	-	-	-
C-F-1	V2 21208-003-69		ISI-21208-003	ISI	-	-	-	-	-	-	-
C5.21	21208-003-69		3" PIPE TO ELBOW	AUG	-	-	-	-	-	-	-
2	1208			OWN	-	-	-	-	-	-	-
				PRE	-	-	-	-	-	-	-
C-F-1	V2 21208-003-7		ISI-21208-003	ISI	-	-	-	-	-	-	-
C5.21	21208-003-7		3" PIPE TO VALVE	AUG	-	-	-	-	-	-	-
2	1208			OWN	-	-	-	-	-	-	-
				PRE	-	-	-	-	-	-	-
C-F-1	V2 21208-003-70		ISI-21208-003	ISI	-	-	-	-	-	-	-
C5.21	21208-003-70		3" ELBOW TO PIPE	AUG	-	-	-	-	-	-	-
2	1208			OWN	-	-	-	-	-	-	-
				PRE	-	-	-	-	-	-	-
C-F-1	V2 21208-003-71		ISI-21208-003	ISI	-	-	-	-	-	-	-
C5.21	21208-003-71		3" PIPE TO ELBOW	AUG	-	-	-	-	-	-	-
2	1208			OWN	-	-	-	-	-	-	-
				PRE	-	-	-	-	-	-	-
C-F-1	V2 21208-003-72		ISI-21208-003	ISI	-	-	-	-	-	-	-
C5.21	21208-003-72		3" ELBOW TO PIPE	AUG	-	-	-	-	-	-	-
2	1208			OWN	-	-	-	-	-	-	-
				PRE	-	-	-	-	-	-	-
C-F-1	V2 21208-003-74		ISI-21208-003	ISI	-	-	-	-	-	-	-
C5.21	21208-003-74		3" PIPE TO ELBOW	AUG	-	-	-	-	-	-	-

Southern Nuclear Operating Company
3rd Interval
VOGTLE-2 ISI PLAN, VERSION 3.0

Category, Item No., Class	Summary No./ComplD/System	Scope / Method / Procedure	Dwg/ISO No. Comp. Desc. Code Case		Period 1		Period 2			Period 3	
					2VR13	2VR14	2VR14A	2VR15	2VR16	2VR17	2VR18
2	1208			OWN	-	-	-	-	-	-	-
				PRE	-	-	-	-	-	-	-
C-F-1	V2 21208-003-75		ISI-21208-003	ISI	-	-	-	-	-	-	-
C5.21	21208-003-75		3" ELBOW TO PIPE	AUG	-	-	-	-	-	-	-
2	1208			OWN	-	-	-	-	-	-	-
				PRE	-	-	-	-	-	-	-
C-F-1	V2 21208-003-76		ISI-21208-003	ISI	-	-	-	-	-	-	-
C5.21	21208-003-76		3" PIPE TO ELBOW	AUG	-	-	-	-	-	-	-
2	1208			OWN	-	-	-	-	-	-	-
				PRE	-	-	-	-	-	-	-
C-F-1	V2 21208-003-77		ISI-21208-003	ISI	-	-	-	-	-	-	-
C5.21	21208-003-77		3" ELBOW TO PIPE	AUG	-	-	-	-	-	-	-
2	1208			OWN	-	-	-	-	-	-	-
				PRE	-	-	-	-	-	-	-
C-F-1	V2 21208-003-78		ISI-21208-003	ISI	-	-	-	-	-	-	-
C5.21	21208-003-78		3" PIPE TO ELBOW	AUG	-	-	-	-	-	-	-
2	1208			OWN	-	-	-	-	-	-	-
				PRE	-	-	-	-	-	-	-
C-F-1	V2 21208-003-79		ISI-21208-003	ISI	-	-	-	-	-	-	-
C5.21	21208-003-79		3" ELBOW TO PIPE	AUG	-	-	-	-	-	-	-
2	1208			OWN	-	-	-	-	-	-	-
				PRE	-	-	-	-	-	-	-
C-F-1	V2 21208-003-8		ISI-21208-003	ISI	-	-	-	-	-	-	-
C5.21	21208-003-8		3" VALVE TO PIPE	AUG	-	-	-	-	-	-	-
2	1208			OWN	-	-	-	-	-	-	-
				PRE	-	-	-	-	-	-	-
C-F-1	V2 21208-003-80		ISI-21208-003	ISI	-	-	-	-	-	-	-
C5.21	21208-003-80		3" PIPE TO PIPE	AUG	-	-	-	-	-	-	-
2	1208			OWN	-	-	-	-	-	-	-
				PRE	-	-	-	-	-	-	-
C-F-1	V2 21208-003-81		ISI-21208-003	ISI	-	-	-	-	-	-	-
C5.21	21208-003-81		3" PIPE TO PIPE	AUG	-	-	-	-	-	-	-
2	1208			OWN	-	-	-	-	-	-	-
				PRE	-	-	-	-	-	-	-
C-F-1	V2 21208-003-81 A		ISI-21208-003	ISI	-	-	-	-	-	-	-
C5.21	21208-003-81 A		3" PIPE TO PIPE	AUG	-	-	-	-	-	-	-
2	1208			OWN	-	-	-	-	-	-	-
				PRE	-	-	-	-	-	-	-
C-F-1	V2 21208-003-84		ISI-21208-003	ISI	-	-	-	-	-	-	-
C5.21	21208-003-84		3" PIPE TO PIPE	AUG	-	-	-	-	-	-	-

Southern Nuclear Operating Company
3rd Interval
VOGTLE-2 ISI PLAN, VERSION 3.0

Category, Item No., Class	Summary No./CompID/System	Scope / Method / Procedure	Dwg/ISO No. Comp. Desc. Code Case		Period 1		Period 2			Period 3	
					2VR13	2VR14	2VR14A	2VR15	2VR16	2VR17	2VR18
2	1208			OWN	-	-	-	-	-	-	-
				PRE	-	-	-	-	-	-	-
C-F-1	V2 21208-003-85		ISI-21208-003	ISI	-	-	-	-	-	-	-
C5.21	21208-003-85		3" PIPE TO PIPE	AUG	-	-	-	-	-	-	-
2	1208			OWN	-	-	-	-	-	-	-
				PRE	-	-	-	-	-	-	-
C-F-1	V2 21208-003-86		ISI-21208-003	ISI	-	-	-	-	-	-	-
C5.21	21208-003-86		3" PIPE TO PIPE	AUG	-	-	-	-	-	-	-
2	1208			OWN	-	-	-	-	-	-	-
				PRE	-	-	-	-	-	-	-
C-F-1	V2 21208-003-87		ISI-21208-003	ISI	-	-	-	-	-	-	-
C5.21	21208-003-87		3" PIPE TO ELBOW	AUG	-	-	-	-	-	-	-
2	1208			OWN	-	-	-	-	-	-	-
				PRE	-	-	-	-	-	-	-
C-F-1	V2 21208-003-88		ISI-21208-003	ISI	-	-	-	-	-	-	-
C5.21	21208-003-88		3" ELBOW TO PIPE	AUG	-	-	-	-	-	-	-
2	1208			OWN	-	-	-	-	-	-	-
				PRE	-	-	-	-	-	-	-
C-F-1	V2 21208-003-89		ISI-21208-003	ISI	-	-	-	-	-	-	-
C5.21	21208-003-89		3" PIPE TO ELBOW	AUG	-	-	-	-	-	-	-
2	1208			OWN	-	-	-	-	-	-	-
				PRE	-	-	-	-	-	-	-
C-F-1	V2 21208-003-9		ISI-21208-003	ISI	-	-	-	-	-	-	-
C5.21	21208-003-9		3" PIPE TO VALVE	AUG	-	-	-	-	-	-	-
2	1208			OWN	-	-	-	-	-	-	-
				PRE	-	-	-	-	-	-	-
C-F-1	V2 21208-003-90		ISI-21208-003	ISI	-	-	-	-	-	-	-
C5.21	21208-003-90		3" ELBOW TO PIPE	AUG	-	-	-	-	-	-	-
2	1208			OWN	-	-	-	-	-	-	-
				PRE	-	-	-	-	-	-	-
C-F-1	V2 21208-003-91	ISI/UT/	ISI-21208-003	ISI	-	-	-	-	-	s	-
C5.21	21208-003-91		3" PIPE TO ELBOW	AUG	-	-	-	-	-	-	-
2	1208			OWN	-	-	-	-	-	-	-
				PRE	-	-	-	-	-	-	-
C-F-1	V2 21208-003-92	ISI/UT/	ISI-21208-003	ISI	-	-	-	-	-	s	-
C5.21	21208-003-92		3" ELBOW TO PIPE	AUG	-	-	-	-	-	-	-
2	1208			OWN	-	-	-	-	-	-	-
				PRE	-	-	-	-	-	-	-
C-F-1	V2 21208-003-93	ISI/UT/	ISI-21208-003	ISI	-	-	-	-	-	s	-
C5.21	21208-003-93		3" PIPE TO ELBOW	AUG	-	-	-	-	-	-	-

Southern Nuclear Operating Company
3rd Interval
VOGTLE-2 ISI PLAN, VERSION 3.0

Category, Item No., Class	Summary No./CompID/System	Scope / Method / Procedure	Dwg/ISO No. Comp. Desc. Code Case		Period 1		Period 2			Period 3	
					2VR13	2VR14	2VR14A	2VR15	2VR16	2VR17	2VR18
	1208			OWN	-	-	-	-	-	-	-
				PRE	-	-	-	-	-	-	-
C-F-1	V2 21208-003-94		ISI-21208-003	ISI	-	-	-	-	-	-	-
C5.21	21208-003-94		3" ELBOW TO PIPE	AUG	-	-	-	-	-	-	-
2	1208			OWN	-	-	-	-	-	-	-
				PRE	-	-	-	-	-	-	-
C-F-1	V2 21208-003-96		ISI-21208-003	ISI	-	-	-	-	-	-	-
C5.21	21208-003-96		3" PIPE TO ELBOW	AUG	-	-	-	-	-	-	-
2	1208			OWN	-	-	-	-	-	-	-
				PRE	-	-	-	-	-	-	-
C-F-1	V2 21208-003-97		ISI-21208-003	ISI	-	-	-	-	-	-	-
C5.21	21208-003-97		3" ELBOW TO PIPE	AUG	-	-	-	-	-	-	-
2	1208			OWN	-	-	-	-	-	-	-
				PRE	-	-	-	-	-	-	-
C-F-1	V2 21208-003-98		ISI-21208-003	ISI	-	-	-	-	-	-	-
C5.21	21208-003-98		3" PIPE TO ELBOW	AUG	-	-	-	-	-	-	-
2	1208			OWN	-	-	-	-	-	-	-
				PRE	-	-	-	-	-	-	-
C-F-1	V2 21208-003-99		ISI-21208-003	ISI	-	-	-	-	-	-	-
C5.21	21208-003-99		3" ELBOW TO PIPE	AUG	-	-	-	-	-	-	-
2	1208			OWN	-	-	-	-	-	-	-
				PRE	-	-	-	-	-	-	-
C-F-1	V2 21208-099-11	ISI/UT/	ISI-21208-099	ISI	-	-	-	-	-	s	-
C5.21	21208-099-11		3" PIPE TO ECC. SWAGE	AUG	-	-	-	-	-	-	-
2	1208			OWN	-	-	-	-	-	-	-
				PRE	-	-	-	-	-	-	-
C-F-1	V2 21208-099-12	ISI/UT/	ISI-21208-099	ISI	-	-	-	s	-	-	-
C5.21	21208-099-12		2" ECC. SWAGE TO TEE	AUG	-	-	-	-	-	-	-
2	1208			OWN	-	-	-	-	-	-	-
				PRE	-	-	-	-	-	-	-
C-F-1	V2 21208-099-13		ISI-21208-099	ISI	-	-	-	-	-	-	-
C5.21	21208-099-13		2" TEE TO SWAGE	AUG	-	-	-	-	-	-	-
2	1208			OWN	-	-	-	-	-	-	-
				PRE	-	-	-	-	-	-	-
C-F-1	V2 21208-099-14		ISI-21208-099	ISI	-	-	-	-	-	-	-
C5.21	21208-099-14		2" TEE TO PIPE	AUG	-	-	-	-	-	-	-
2	1208			OWN	-	-	-	-	-	-	-
				PRE	-	-	-	-	-	-	-
C-F-1	V2 21208-099-15		ISI-21208-099	ISI	-	-	-	-	-	-	-
C5.21	21208-099-15		2" PIPE TO ELBOW	AUG	-	-	-	-	-	-	-

Southern Nuclear Operating Company
3rd Interval
VOGTLE-2 ISI PLAN, VERSION 3.0

Category, Item No., Class	Summary No./CompID/System	Scope / Method / Procedure	Dwg/ISO No. Comp. Desc. Code Case		Period 1		Period 2			Period 3	
					2VR13	2VR14	2VR14A	2VR15	2VR16	2VR17	2VR18
2	1208			OWN	-	-	-	-	-	-	-
				PRE	-	-	-	-	-	-	-
C-F-1	V2 21208-099-16		ISI-21208-099	ISI	-	-	-	-	-	-	-
C5.21	21208-099-16		2" ELBOW TO PIPE	AUG	-	-	-	-	-	-	-
2	1208			OWN	-	-	-	-	-	-	-
				PRE	-	-	-	-	-	-	-
C-F-1	V2 21208-099-16A		ISI-21208-099	ISI	-	-	-	-	-	-	-
C5.21	21208-099-16A		2" PIPE TO TEE	AUG	-	-	-	-	-	-	-
2	1208			OWN	-	-	-	-	-	-	-
				PRE	-	-	-	-	-	-	-
C-F-1	V2 21208-099-16B		ISI-21208-099	ISI	-	-	-	-	-	-	-
C5.21	21208-099-16B		2" TEE TO PIPE	AUG	-	-	-	-	-	-	-
2	1208			OWN	-	-	-	-	-	-	-
				PRE	-	-	-	-	-	-	-
C-F-1	V2 21208-099-18		ISI-21208-099	ISI	-	-	-	-	-	-	-
C5.21	21208-099-18		2" PIPE TO VALVE	AUG	-	-	-	-	-	-	-
2	1208			OWN	-	-	-	-	-	-	-
				PRE	-	-	-	-	-	-	-
C-F-1	V2 21208-099-2		ISI-21208-099	ISI	-	-	-	-	-	-	-
C5.21	21208-099-2		2" PIPE TO VALVE	AUG	-	-	-	-	-	-	-
2	1208			OWN	-	-	-	-	-	-	-
				PRE	-	-	-	-	-	-	-
C-F-1	V2 21208-099-3		ISI-21208-099	ISI	-	-	-	-	-	-	-
C5.21	21208-099-3		2" VALVE TO SWAGE	AUG	-	-	-	-	-	-	-
2	1208			OWN	-	-	-	-	-	-	-
				PRE	-	-	-	-	-	-	-
C-F-1	V2 21208-099-4		ISI-21208-099	ISI	-	-	-	-	-	-	-
C5.21	21208-099-4		3" SWAGE TO PIPE	AUG	-	-	-	-	-	-	-
2	1208			OWN	-	-	-	-	-	-	-
				PRE	-	-	-	-	-	-	-
C-F-1	V2 21208-099-6		ISI-21208-099	ISI	-	-	-	-	-	-	-
C5.21	21208-099-6		3" PIPE TO ELBOW	AUG	-	-	-	-	-	-	-
2	1208			OWN	-	-	-	-	-	-	-
				PRE	-	-	-	-	-	-	-
C-F-1	V2 21208-099-7		ISI-21208-099	ISI	-	-	-	-	-	-	-
C5.21	21208-099-7		3" ELBOW TO PIPE	AUG	-	-	-	-	-	-	-
2	1208			OWN	-	-	-	-	-	-	-
				PRE	-	-	-	-	-	-	-
C-F-1	V2 21208-099-8		ISI-21208-099	ISI	-	-	-	-	-	-	-
C5.21	21208-099-8		3" PIPE TO FLOW ORIFICE (AI 87-0131)	AUG	-	-	-	-	-	-	-

Southern Nuclear Operating Company
3rd Interval
VOGTLE-2 ISI PLAN, VERSION 3.0

Category, Item No., Class	Summary No./ComplD/System 1208	Scope / Method / Procedure	Dwg/ISO No. Comp. Desc. Code Case		Period 1		Period 2			Period 3	
					2VR13	2VR14	2VR14A	2VR15	2VR16	2VR17	2VR18
				OWN	-	-	-	-	-	-	-
				PRE	-	-	-	-	-	-	-
C-F-1	V2 21208-099-9		ISI-21208-099	ISI	-	-	-	-	-	-	-
C5.21	21208-099-9		3" FLOW ORIFICE TO PIPE (AI 87-0131)	AUG	-	-	-	-	-	-	-
2	1208			OWN	-	-	-	-	-	-	-
				PRE	-	-	-	-	-	-	-
C-F-1	V2 21208-101-1		ISI-21208-101	ISI	-	-	-	-	-	-	-
C5.21	21208-101-1		2" SOCKOLET TO PIPE	AUG	-	-	-	-	-	-	-
2	1208			OWN	-	-	-	-	-	-	-
				PRE	-	-	-	-	-	-	-
C-F-1	V2 21208-101-10		ISI-21208-101	ISI	-	-	-	-	-	-	-
C5.21	21208-101-10		3" PIPE TO PIPE	AUG	-	-	-	-	-	-	-
2	1208			OWN	-	-	-	-	-	-	-
				PRE	-	-	-	-	-	-	-
C-F-1	V2 21208-101-10 A		ISI-21208-101	ISI	-	-	-	-	-	-	-
C5.21	21208-101-10 A		3" PIPE TO PIPE	AUG	-	-	-	-	-	-	-
2	1208			OWN	-	-	-	-	-	-	-
				PRE	-	-	-	-	-	-	-
C-F-1	V2 21208-101-11		ISI-21208-101	ISI	-	-	-	-	-	-	-
C5.21	21208-101-11		3" PIPE TO ECC. SWAGE	AUG	-	-	-	-	-	-	-
2	1208			OWN	-	-	-	-	-	-	-
				PRE	-	-	-	-	-	-	-
C-F-1	V2 21208-101-12		ISI-21208-101	ISI	-	-	-	-	-	-	-
C5.21	21208-101-12		2" ECC. SWAGE TO TEE	AUG	-	-	-	-	-	-	-
2	1208			OWN	-	-	-	-	-	-	-
				PRE	-	-	-	-	-	-	-
C-F-1	V2 21208-101-13		ISI-21208-101	ISI	-	-	-	-	-	-	-
C5.21	21208-101-13		2" TEE TO SWAGE	AUG	-	-	-	-	-	-	-
2	1208			OWN	-	-	-	-	-	-	-
				PRE	-	-	-	-	-	-	-
C-F-1	V2 21208-101-14		ISI-21208-101	ISI	-	-	-	-	-	-	-
C5.21	21208-101-14		2" TEE TO PIPE	AUG	-	-	-	-	-	-	-
2	1208			OWN	-	-	-	-	-	-	-
				PRE	-	-	-	-	-	-	-
C-F-1	V2 21208-101-15		ISI-21208-101	ISI	-	-	-	-	-	-	-
C5.21	21208-101-15		2" PIPE TO ELBOW	AUG	-	-	-	-	-	-	-
2	1208			OWN	-	-	-	-	-	-	-
				PRE	-	-	-	-	-	-	-
C-F-1	V2 21208-101-16		ISI-21208-101	ISI	-	-	-	-	-	-	-
C5.21	21208-101-16		2" ELBOW TO PIPE	AUG	-	-	-	-	-	-	-

Southern Nuclear Operating Company
3rd Interval
VOGTLE-2 ISI PLAN, VERSION 3.0

Category, Item No., Class	Summary No./ComplD/System	Scope / Method / Procedure	Dwg/ISO No. Comp. Desc. Code Case		Period 1		Period 2			Period 3	
					2VR13	2VR14	2VR14A	2VR15	2VR16	2VR17	2VR18
2	1208			OWN	-	-	-	-	-	-	-
				PRE	-	-	-	-	-	-	-
C-F-1	V2 21208-101-16A		ISI-21208-101	ISI	-	-	-	-	-	-	-
C5.21	21208-101-16A		2" PIPE TO TEE	AUG	-	-	-	-	-	-	-
2	1208			OWN	-	-	-	-	-	-	-
				PRE	-	-	-	-	-	-	-
C-F-1	V2 21208-101-16B		ISI-21208-101	ISI	-	-	-	-	-	-	-
C5.21	21208-101-16B		2" TEE TO PIPE	AUG	-	-	-	-	-	-	-
2	1208			OWN	-	-	-	-	-	-	-
				PRE	-	-	-	-	-	-	-
C-F-1	V2 21208-101-18		ISI-21208-101	ISI	-	-	-	-	-	-	-
C5.21	21208-101-18		2" PIPE TO VALVE	AUG	-	-	-	-	-	-	-
2	1208			OWN	-	-	-	-	-	-	-
				PRE	-	-	-	-	-	-	-
C-F-1	V2 21208-101-2		ISI-21208-101	ISI	-	-	-	-	-	-	-
C5.21	21208-101-2		2" PIPE TO VALVE	AUG	-	-	-	-	-	-	-
2	1208			OWN	-	-	-	-	-	-	-
				PRE	-	-	-	-	-	-	-
C-F-1	V2 21208-101-3		ISI-21208-101	ISI	-	-	-	-	-	-	-
C5.21	21208-101-3		2" VALVE TO SWAGE	AUG	-	-	-	-	-	-	-
2	1208			OWN	-	-	-	-	-	-	-
				PRE	-	-	-	-	-	-	-
C-F-1	V2 21208-101-4		ISI-21208-101	ISI	-	-	-	-	-	-	-
C5.21	21208-101-4		3" SWAGE TO PIPE	AUG	-	-	-	-	-	-	-
2	1208			OWN	-	-	-	-	-	-	-
				PRE	-	-	-	-	-	-	-
C-F-1	V2 21208-101-6		ISI-21208-101	ISI	-	-	-	-	-	-	-
C5.21	21208-101-6		3" PIPE TO ELBOW	AUG	-	-	-	-	-	-	-
2	1208			OWN	-	-	-	-	-	-	-
				PRE	-	-	-	-	-	-	-
C-F-1	V2 21208-101-7		ISI-21208-101	ISI	-	-	-	-	-	-	-
C5.21	21208-101-7		3" ELBOW TO PIPE	AUG	-	-	-	-	-	-	-
2	1208			OWN	-	-	-	-	-	-	-
				PRE	-	-	-	-	-	-	-
C-F-1	V2 21208-101-8		ISI-21208-101	ISI	-	-	-	-	-	-	-
C5.21	21208-101-8		3" PIPE TO FLOW ORIFICE	AUG	-	-	-	-	-	-	-
2	1208			OWN	-	-	-	-	-	-	-
				PRE	-	-	-	-	-	-	-
C-F-1	V2 21208-101-9		ISI-21208-101	ISI	-	-	-	-	-	-	-
C5.21	21208-101-9		3" FLOW ORIFICE TO PIPE	AUG	-	-	-	-	-	-	-

Southern Nuclear Operating Company
3rd Interval
VOGTLE-2 ISI PLAN, VERSION 3.0

Category, Item No., Class	Summary No./CompID/System	Scope / Method / Procedure	Dwg/ISO No. Comp. Desc. Code Case		Period 1		Period 2			Period 3	
					2VR13	2VR14	2VR14A	2VR15	2VR16	2VR17	2VR18
2	1208			OWN	-	-	-	-	-	-	-
				PRE	-	-	-	-	-	-	-
C-F-1	V2 21208-144-1		ISI-21208-144	ISI	-	-	-	-	-	-	-
C5.21	21208-144-1		4" FLANGE TO PIPE	AUG	-	-	-	-	-	-	-
2	1208			OWN	-	-	-	-	-	-	-
				PRE	-	-	-	-	-	-	-
C-F-1	V2 21208-144-10		ISI-21208-144	ISI	-	-	-	-	-	-	-
C5.21	21208-144-10		4" PIPE TO ELBOW	AUG	-	-	-	-	-	-	-
2	1208			OWN	-	-	-	-	-	-	-
				PRE	-	-	-	-	-	-	-
C-F-1	V2 21208-144-11		ISI-21208-144	ISI	-	-	-	-	-	-	-
C5.21	21208-144-11		4" ELBOW TO PIPE	AUG	-	-	-	-	-	-	-
2	1208			OWN	-	-	-	-	-	-	-
				PRE	-	-	-	-	-	-	-
C-F-1	V2 21208-144-13		ISI-21208-144	ISI	-	-	-	-	-	-	-
C5.21	21208-144-13		4" PIPE TO 2" BRANCH CONNECTION	AUG	-	-	-	-	-	-	-
2	1208			OWN	-	-	-	-	-	-	-
				PRE	-	-	-	-	-	-	-
C-F-1	V2 21208-144-14		ISI-21208-144	ISI	-	-	-	-	-	-	-
C5.21	21208-144-14		4" PIPE TO ELBOW	AUG	-	-	-	-	-	-	-
2	1208			OWN	-	-	-	-	-	-	-
				PRE	-	-	-	-	-	-	-
C-F-1	V2 21208-144-15		ISI-21208-144	ISI	-	-	-	-	-	-	-
C5.21	21208-144-15		4" ELBOW TO PIPE	AUG	-	-	-	-	-	-	-
2	1208			OWN	-	-	-	-	-	-	-
				PRE	-	-	-	-	-	-	-
C-F-1	V2 21208-144-16		ISI-21208-144	ISI	-	-	-	-	-	-	-
C5.21	21208-144-16		4" PIPE TO VALVE	AUG	-	-	-	-	-	-	-
2	1208			OWN	-	-	-	-	-	-	-
				PRE	-	-	-	-	-	-	-
C-F-1	V2 21208-144-17		ISI-21208-144	ISI	-	-	-	-	-	-	-
C5.21	21208-144-17		4" VALVE TO PIPE	AUG	-	-	-	-	-	-	-
2	1208			OWN	-	-	-	-	-	-	-
				PRE	-	-	-	-	-	-	-
C-F-1	V2 21208-144-18		ISI-21208-144	ISI	-	-	-	-	-	-	-
C5.21	21208-144-18		4" PIPE TO TEE	AUG	-	-	-	-	-	-	-
2	1208			OWN	-	-	-	-	-	-	-
				PRE	-	-	-	-	-	-	-
C-F-1	V2 21208-144-19		ISI-21208-144	ISI	-	-	-	-	-	-	-
C5.21	21208-144-19		4" TEE TO PIPE	AUG	-	-	-	-	-	-	-

Southern Nuclear Operating Company
3rd Interval
VOGTLE-2 ISI PLAN, VERSION 3.0

Category, Item No., Class	Summary No./CompID/System	Scope / Method / Procedure	Dwg/ISO No. Comp. Desc. Code Case		Period 1		Period 2			Period 3	
					2VR13	2VR14	2VR14A	2VR15	2VR16	2VR17	2VR18
2	1208			OWN	-	-	-	-	-	-	-
				PRE	-	-	-	-	-	-	-
C-F-1	V2 21208-144-2	ISI/UT/	ISI-21208-144	ISI	-	-	-	-	-	-	-
C5.21	21208-144-2		4" PIPE TO ELBOW	AUG	-	-	-	-	-	-	-
2	1208			OWN	-	-	-	-	-	-	-
				PRE	-	-	-	-	-	-	-
C-F-1	V2 21208-144-20		ISI-21208-144	ISI	-	-	-	-	-	-	-
C5.21	21208-144-20		4" PIPE TO VALVE	AUG	-	-	-	-	-	-	-
2	1208			OWN	-	-	-	-	-	-	-
				PRE	-	-	-	-	-	-	-
C-F-1	V2 21208-144-21		ISI-21208-144	ISI	-	-	-	-	-	-	-
C5.21	21208-144-21		4" VALVE TO PIPE	AUG	-	-	-	-	-	-	-
2	1208			OWN	-	-	-	-	-	-	-
				PRE	-	-	-	-	-	-	-
C-F-1	V2 21208-144-22		ISI-21208-144	ISI	-	-	-	-	-	-	-
C5.21	21208-144-22		4" PIPE TO ELBOW	AUG	-	-	-	-	-	-	-
2	1208			OWN	-	-	-	-	-	-	-
				PRE	-	-	-	-	-	-	-
C-F-1	V2 21208-144-23		ISI-21208-144	ISI	-	-	-	-	-	-	-
C5.21	21208-144-23		4" ELBOW TO PIPE	AUG	-	-	-	-	-	-	-
2	1208			OWN	-	-	-	-	-	-	-
				PRE	-	-	-	-	-	-	-
C-F-1	V2 21208-144-24		ISI-21208-144	ISI	-	-	-	-	-	-	-
C5.21	21208-144-24		4" PIPE TO PIPE	AUG	-	-	-	-	-	-	-
2	1208			OWN	-	-	-	-	-	-	-
				PRE	-	-	-	-	-	-	-
C-F-1	V2 21208-144-25		ISI-21208-144	ISI	-	-	-	-	-	-	-
C5.21	21208-144-25		4" PIPE TO PIPE	AUG	-	-	-	-	-	-	-
2	1208			OWN	-	-	-	-	-	-	-
				PRE	-	-	-	-	-	-	-
C-F-1	V2 21208-144-26		ISI-21208-144	ISI	-	-	-	-	-	-	-
C5.21	21208-144-26		4" PIPE TO ELBOW	AUG	-	-	-	-	-	-	-
2	1208			OWN	-	-	-	-	-	-	-
				PRE	-	-	-	-	-	-	-
C-F-1	V2 21208-144-27		ISI-21208-144	ISI	-	-	-	-	-	-	-
C5.21	21208-144-27		4" ELBOW TO PIPE	AUG	-	-	-	-	-	-	-
2	1208			OWN	-	-	-	-	-	-	-
				PRE	-	-	-	-	-	-	-
C-F-1	V2 21208-144-28		ISI-21208-144	ISI	-	-	-	-	-	-	-
C5.21	21208-144-28		4" PIPE TO ELBOW	AUG	-	-	-	-	-	-	-

Southern Nuclear Operating Company
3rd Interval
VOGTLE-2 ISI PLAN, VERSION 3.0

Category, Item No., Class	Summary No./CompID/System	Scope / Method / Procedure	Dwg/ISO No. Comp. Desc. Code Case		Period 1		Period 2			Period 3	
					2VR13	2VR14	2VR14A	2VR15	2VR16	2VR17	2VR18
2	1208			OWN	-	-	-	-	-	-	-
				PRE	-	-	-	-	-	-	-
C-F-1	V2 21208-144-29		ISI-21208-144	ISI	-	-	-	-	-	-	-
C5.21	21208-144-29		4" ELBOW TO PIPE	AUG	-	-	-	-	-	-	-
2	1208			OWN	-	-	-	-	-	-	-
				PRE	-	-	-	-	-	-	-
C-F-1	V2 21208-144-3		ISI-21208-144	ISI	-	-	-	-	-	-	-
C5.21	21208-144-3		4" ELBOW TO PIPE	AUG	-	-	-	-	-	-	-
2	1208			OWN	-	-	-	-	-	-	-
				PRE	-	-	-	-	-	-	-
C-F-1	V2 21208-144-30		ISI-21208-144	ISI	-	-	-	-	-	-	-
C5.21	21208-144-30		4" PIPE TO TEE	AUG	-	-	-	-	-	-	-
2	1208			OWN	-	-	-	-	-	-	-
				PRE	-	-	-	-	-	-	-
C-F-1	V2 21208-144-4	ISI/UT/	ISI-21208-144	ISI	-	-	-	s	-	-	-
C5.21	21208-144-4		4" PIPE TO FLANGE	AUG	-	-	-	-	-	-	-
2	1208			OWN	-	-	-	-	-	-	-
				PRE	-	-	-	-	-	-	-
C-F-1	V2 21208-144-5		ISI-21208-144	ISI	-	-	-	-	-	-	-
C5.21	21208-144-5		4" FLANGE TO PIPE	AUG	-	-	-	-	-	-	-
2	1208			OWN	-	-	-	-	-	-	-
				PRE	-	-	-	-	-	-	-
C-F-1	V2 21208-144-6		ISI-21208-144	ISI	-	-	-	-	-	-	-
C5.21	21208-144-6		4" PIPE TO ELBOW	AUG	-	-	-	-	-	-	-
2	1208			OWN	-	-	-	-	-	-	-
				PRE	-	-	-	-	-	-	-
C-F-1	V2 21208-144-7		ISI-21208-144	ISI	-	-	-	-	-	-	-
C5.21	21208-144-7		4" ELBOW TO PIPE	AUG	-	-	-	-	-	-	-
2	1208			OWN	-	-	-	-	-	-	-
				PRE	-	-	-	-	-	-	-
C-F-1	V2 21208-144-8		ISI-21208-144	ISI	-	-	-	-	-	-	-
C5.21	21208-144-8		4" PIPE TO PIPE	AUG	-	-	-	-	-	-	-
2	1208			OWN	-	-	-	-	-	-	-
				PRE	-	-	-	-	-	-	-
C-F-1	V2 21208-144-9		ISI-21208-144	ISI	-	-	-	-	-	-	-
C5.21	21208-144-9		4" PIPE TO PIPE	AUG	-	-	-	-	-	-	-
2	1208			OWN	-	-	-	-	-	-	-
				PRE	-	-	-	-	-	-	-
C-F-1	V2 21208-145-1		ISI-21208-145	ISI	-	-	-	-	-	-	-
C5.21	21208-145-1		4" FLANGE TO PIPE	AUG	-	-	-	-	-	-	-

Southern Nuclear Operating Company
3rd Interval
VOGTLE-2 ISI PLAN, VERSION 3.0

Category, Item No., Class	Summary No./CompID/System 1208	Scope / Method / Procedure	Dwg/ISO No. Comp. Desc. Code Case		Period 1		Period 2			Period 3	
					2VR13	2VR14	2VR14A	2VR15	2VR16	2VR17	2VR18
				OWN	-	-	-	-	-	-	-
				PRE	-	-	-	-	-	-	-
C-F-1	V2 21208-145-10		ISI-21208-145	ISI	-	-	-	-	-	-	-
C5.21	21208-145-10		4" ELBOW TO PIPE	AUG	-	-	-	-	-	-	-
2	1208			OWN	-	-	-	-	-	-	-
				PRE	-	-	-	-	-	-	-
C-F-1	V2 21208-145-12		ISI-21208-145	ISI	-	-	-	-	-	-	-
C5.21	21208-145-12		4" PIPE TO 2" BRANCH CONNECTION	AUG	-	-	-	-	-	-	-
2	1208			OWN	-	-	-	-	-	-	-
				PRE	-	-	-	-	-	-	-
C-F-1	V2 21208-145-13		ISI-21208-145	ISI	-	-	-	-	-	-	-
C5.21	21208-145-13		4" PIPE TO ELBOW	AUG	-	-	-	-	-	-	-
2	1208			OWN	-	-	-	-	-	-	-
				PRE	-	-	-	-	-	-	-
C-F-1	V2 21208-145-14		ISI-21208-145	ISI	-	-	-	-	-	-	-
C5.21	21208-145-14		4" ELBOW TO PIPE	AUG	-	-	-	-	-	-	-
2	1208			OWN	-	-	-	-	-	-	-
				PRE	-	-	-	-	-	-	-
C-F-1	V2 21208-145-15		ISI-21208-145	ISI	-	-	-	-	-	-	-
C5.21	21208-145-15		4" PIPE TO VALVE	AUG	-	-	-	-	-	-	-
2	1208			OWN	-	-	-	-	-	-	-
				PRE	-	-	-	-	-	-	-
C-F-1	V2 21208-145-16		ISI-21208-145	ISI	-	-	-	-	-	-	-
C5.21	21208-145-16		4" VALVE TO PIPE	AUG	-	-	-	-	-	-	-
2	1208			OWN	-	-	-	-	-	-	-
				PRE	-	-	-	-	-	-	-
C-F-1	V2 21208-145-17		ISI-21208-145	ISI	-	-	-	-	-	-	-
C5.21	21208-145-17		4" PIPE TO TEE	AUG	-	-	-	-	-	-	-
2	1208			OWN	-	-	-	-	-	-	-
				PRE	-	-	-	-	-	-	-
C-F-1	V2 21208-145-18		ISI-21208-145	ISI	-	-	-	-	-	-	-
C5.21	21208-145-18		4" TEE TO PIPE	AUG	-	-	-	-	-	-	-
2	1208			OWN	-	-	-	-	-	-	-
				PRE	-	-	-	-	-	-	-
C-F-1	V2 21208-145-19	ISI/UT/	ISI-21208-145	ISI	-	-	-	s	-	-	-
C5.21	21208-145-19		4" PIPE TO VALVE	AUG	-	-	-	-	-	-	-
2	1208			OWN	-	-	-	-	-	-	-
				PRE	-	-	-	-	-	-	-
C-F-1	V2 21208-145-2	ISI/UT/	ISI-21208-145	ISI	-	-	-	s	-	-	-
C5.21	21208-145-2		4" PIPE TO ELBOW	AUG	-	-	-	-	-	-	-

Southern Nuclear Operating Company
3rd Interval
VOGTLE-2 ISI PLAN, VERSION 3.0

Category, Item No., Class	Summary No./CompID/System	Scope / Method / Procedure	Dwg/ISO No. Comp. Desc. Code Case		Period 1		Period 2		Period 3	
					2VR13	2VR14	2VR14A	2VR15	2VR16	2VR17
2	1208			OWN	-	-	-	-	-	-
				PRE	-	-	-	-	-	-
C-F-1	V2 21208-145-3		ISI-21208-145	ISI	-	-	-	-	-	-
C5.21	21208-145-3		4" ELBOW TO PIPE	AUG	-	-	-	-	-	-
2	1208			OWN	-	-	-	-	-	-
				PRE	-	-	-	-	-	-
C-F-1	V2 21208-145-4		ISI-21208-145	ISI	-	-	-	-	-	-
C5.21	21208-145-4		4" PIPE TO FLANGE	AUG	-	-	-	-	-	-
2	1208			OWN	-	-	-	-	-	-
				PRE	-	-	-	-	-	-
C-F-1	V2 21208-145-5		ISI-21208-145	ISI	-	-	-	-	-	-
C5.21	21208-145-5		4" FLANGE TO PIPE	AUG	-	-	-	-	-	-
2	1208			OWN	-	-	-	-	-	-
				PRE	-	-	-	-	-	-
C-F-1	V2 21208-145-6		ISI-21208-145	ISI	-	-	-	-	-	-
C5.21	21208-145-6		4" PIPE TO ELBOW	AUG	-	-	-	-	-	-
2	1208			OWN	-	-	-	-	-	-
				PRE	-	-	-	-	-	-
C-F-1	V2 21208-145-7		ISI-21208-145	ISI	-	-	-	-	-	-
C5.21	21208-145-7		4" ELBOW TO PIPE	AUG	-	-	-	-	-	-
2	1208			OWN	-	-	-	-	-	-
				PRE	-	-	-	-	-	-
C-F-1	V2 21208-145-8		ISI-21208-145	ISI	-	-	-	-	-	-
C5.21	21208-145-8		4" PIPE TO PIPE	AUG	-	-	-	-	-	-
2	1208			OWN	-	-	-	-	-	-
				PRE	-	-	-	-	-	-
C-F-1	V2 21208-145-9		ISI-21208-145	ISI	-	-	-	-	-	-
C5.21	21208-145-9		4" PIPE TO ELBOW	AUG	-	-	-	-	-	-
2	1208			OWN	-	-	-	-	-	-
				PRE	-	-	-	-	-	-
C-F-1	V2 21208-099-1	ISI/PT/	ISI-21208-099	ISI	-	-	-	s	-	-
C5.30	21208-099-1		2" SOCKOLET TO PIPE	AUG	-	-	-	s	-	-
2	1208			OWN	-	-	-	-	-	-
				PRE	-	-	-	-	-	-
C-F-1	V2 21204-006-19		ISI-21204-006	ISI	-	-	-	-	-	-
C5.41	21204-006-19		24" PIPE TO 3" BRANCH CONNECTION	AUG	-	-	-	-	-	-
2	1204			OWN	-	-	-	-	-	-
				PRE	-	-	-	-	-	-
C-F-1	V2 21204-006-23		ISI-21204-006	ISI	-	-	-	-	-	-
C5.41	21204-006-23		24" PIPE TO 8" BRANCH CONNECTION	AUG	-	-	-	-	-	-

Southern Nuclear Operating Company
3rd Interval
VOGTLE-2 ISI PLAN, VERSION 3.0

Category, Item No., Class	Summary No./CompID/System	Scope / Method / Procedure	Dwg/ISO No. Comp. Desc. Code Case		Period 1		Period 2			Period 3	
					2VR13	2VR14	2VR14A	2VR15	2VR16	2VR17	2VR18
2	1204			OWN	-	-	-	-	-	-	-
				PRE	-	-	-	-	-	-	-
C-F-1	V2 21204-006-42		ISI-21204-006	ISI	-	-	-	-	-	-	-
C5.41	21204-006-42		24" PIPE TO 8" BRANCH CONNECTION	AUG	-	-	-	-	-	-	-
2	1204			OWN	-	-	-	-	-	-	-
				PRE	-	-	-	-	-	-	-
C-F-1	V2 21204-006-60		ISI-21204-006	ISI	-	-	-	-	-	-	-
C5.41	21204-006-60		24" PIPE TO 14" BRANCH CONNECTION	AUG	-	-	-	-	-	-	-
2	1204			OWN	-	-	-	-	-	-	-
				PRE	-	-	-	-	-	-	-
C-F-1	V2 21204-006-63		ISI-21204-006	ISI	-	-	-	-	-	-	-
C5.41	21204-006-63		24" PIPE TO 12" BRANCH CONNECTION	AUG	-	-	-	-	-	-	-
2	1204			OWN	-	-	-	-	-	-	-
				PRE	-	-	-	-	-	-	-
C-F-1	V2 21204-006-67		ISI-21204-006	ISI	-	-	-	-	-	-	-
C5.41	21204-006-67		24" PIPE TO 12" BRANCH CONNECTION	AUG	-	-	-	-	-	-	-
2	1204			OWN	-	-	-	-	-	-	-
				PRE	-	-	-	-	-	-	-
C-F-1	V2 21204-006-68		ISI-21204-006	ISI	-	-	-	-	-	-	-
C5.41	21204-006-68		24" PIPE TO 8" BRANCH CONNECTION	AUG	-	-	-	-	-	-	-
2	1204			OWN	-	-	-	-	-	-	-
				PRE	-	-	-	-	-	-	-
C-F-1	V2 21204-006-69		ISI-21204-006	ISI	-	-	-	-	-	-	-
C5.41	21204-006-69		24" PIPE TO 2" BRANCH CONNECTION	AUG	-	-	-	-	-	-	-
2	1204			OWN	-	-	-	-	-	-	-
				PRE	-	-	-	-	-	-	-
C-F-1	V2 21204-007-13		ISI-21204-007	ISI	-	-	-	-	-	-	-
C5.41	21204-007-13		10" PIPE TO 2" BRANCH CONNECTION	AUG	-	-	-	-	-	-	-
2	1204			OWN	-	-	-	-	-	-	-
				PRE	-	-	-	-	-	-	-
C-F-1	V2 21204-P6-003-W02	ISI/PT/	ISI-21204-P6-003	ISI	-	-	-	-	-	-	-
C5.41	21204-P6-003-W02		PUMP CASING TO SUCTION NOZZLE	AUG	-	-	-	-	-	-	-
2	1204		WELD	OWN	-	-	-	-	-	-	-
				PRE	-	-	-	-	-	-	-
C-F-1	V2 21204-P6-004-W02		ISI-21204-P6-004	ISI	-	-	-	-	-	-	-
C5.41	21204-P6-004-W02		PUMP CASING TO SUCTION NOZZLE	AUG	-	-	-	-	-	-	-
2	1204		WELD	OWN	-	-	-	-	-	-	-
				PRE	-	-	-	-	-	-	-

Southern Nuclear Operating Company
3rd Interval
VOGTLE-2 ISI PLAN, VERSION 3.0

Category, Item No., Class	Summary No./ComplD/System	Scope / Method / Procedure	Dwg/ISO No. Comp. Desc. Code Case		Period 1		Period 2			Period 3	
					2VR13	2VR14	2VR14A	2VR15	2VR16	2VR17	2VR18
C-F-1	V2 21208-003-18		ISI-21208-003	ISI	-	-	-	-	-	-	-
C5.41	21208-003-18		3" PIPE TO 2" BRANCH CONNECTION	AUG	-	-	-	-	-	-	-
2	1208			OWN	-	-	-	-	-	-	-
				PRE	-	-	-	-	-	-	-
C-F-1	V2 21208-099-5		ISI-21208-099	ISI	-	-	-	-	-	-	-
C5.41	21208-099-5		3" PIPE TO 2" BRANCH CONNECTION	AUG	-	-	-	-	-	-	-
2	1208			OWN	-	-	-	-	-	-	-
				PRE	-	-	-	-	-	-	-
C-F-1	V2 21208-101-5		ISI-21208-101	ISI	-	-	-	-	-	-	-
C5.41	21208-101-5		3" PIPE TO 2" BRANCH CONNECTION	AUG	-	-	-	-	-	-	-
2	1208			OWN	-	-	-	-	-	-	-
				PRE	-	-	-	-	-	-	-
C-F-1	V2 21208-411-40 A		ISI-21208-411	ISI	-	-	-	-	-	-	-
C5.41	21208-411-40 A		8" PIPE TO 3" BRANCH CONNECTION	AUG	-	-	-	-	-	-	-
2	1208			OWN	-	-	-	-	-	-	-
				PRE	-	-	-	-	-	-	-
C-F-1	V2 21208-P6-002-W01	ISI/PT/	ISI-21208-P6-002	ISI	-	-	-	-	-	s	-
C5.41	21208-P6-002-W01		PUMP CASING TO 6" SUCTION NOZZLE	AUG	-	-	-	-	-	-	-
2	1208		WELD	OWN	-	-	-	-	-	-	-
				PRE	-	-	-	-	-	-	-
C-F-1	V2 21208-P6-002-W02	ISI/PT/	ISI-21208-P6-002	ISI	-	-	-	-	-	s	-
C5.41	21208-P6-002-W02		DISCHARGE NOZZLE TO PUMP CASING	AUG	-	-	-	-	-	-	-
2	1208			OWN	-	-	-	-	-	-	-
				PRE	-	-	-	-	-	-	-
C-F-1	V2 21208-P6-003-W01		ISI-21208-P6-003	ISI	-	-	-	-	-	-	-
C5.41	21208-P6-003-W01		PUMP CASING TO 6" SUCTION NOZZLE	AUG	-	-	-	-	-	-	-
2	1208		WELD	OWN	-	-	-	-	-	-	-
				PRE	-	-	-	-	-	-	-
C-F-1	V2 21208-P6-003-W02		ISI-21208-P6-003	ISI	-	-	-	-	-	-	-
C5.41	21208-P6-003-W02		DISCHARGE NOZZLE TO PUMP CASING	AUG	-	-	-	-	-	-	-
2	1208			OWN	-	-	-	-	-	-	-
				PRE	-	-	-	-	-	-	-

**Vogtle Nuclear Plant
Code Compliance Scheduling Summary - 3rd Interval
ISI - Code Edition - 2001 Edition with 2003 Addenda**

Cat.	Item No.	Code Case	Population	Percent Required	Actual Required	Round Up	Total Exams	Period 1			Period 2			Period 3		
								Count	Actual Period	Round Up	Count	Actual Period	Round Up	Count	Actual Period	Round Up
C-F-2	C5.51		448	7.50%	33.6	34	35	15	44.64%	45%	11	77.38%	77%	9	104.17%	103%
C-F-2	C5.60		212	7.50%	15.9	16	16	0	0%	0%	9	56.60%	57%	7	100.63%	100%
C-F-2	C5.81		4	7.50%	0.3	1	1	1	333.33%	100%	0	333.33%	100%	0	333.33%	100%
Total:			664		50	51	52	16	32%	32%	20	72%	71%	16	104%	101%

Southern Nuclear Operating Company
3rd Interval
VOGTLE-2 ISI PLAN, VERSION 3.0

Category, Item No., Class	Summary No./ComplD/System	Scope / Method / Procedure	Dwg/ISO No. Comp. Desc. Code Case		Period 1		Period 2		Period 3	
					2VR13	2VR14	2VR14A	2VR15	2VR16	2VR17
C-F-2 C5.51 2	V2 21301-001-1 21301-001-1 1301	ISI/UT/NMP-ES-024-502	ISI-21301-001 28" PENETRATION TO PIPE (TS 5.5.16)	ISI AUG OWN PRE	-	s	-	-	-	-
C-F-2 C5.51 2	V2 21301-001-10 21301-001-10 1301		ISI-21301-001 6" OUTLET TO FLANGE	ISI AUG OWN PRE	-	-	-	-	-	-
C-F-2 C5.51 2	V2 21301-001-11 21301-001-11 1301		ISI-21301-001 29 1/2" PIPE TO VALVE (TS 5.5.16)	ISI AUG OWN PRE	-	-	-	-	-	-
C-F-2 C5.51 2	V2 21301-001-12 21301-001-12 1301	ISI/UT/NMP-ES-024-502	ISI-21301-001 VALVE TO 29 1/2" PIPE (TS 5.5.16)	ISI AUG OWN PRE	-	s	-	-	-	-
C-F-2 C5.51 2	V2 21301-001-14 21301-001-14 1301	ISI/UT/NMP-ES-024-502	ISI-21301-001 29 1/2" PIPE TO VALVE (TS 5.5.16)	ISI AUG OWN PRE	-	s	-	-	-	-
C-F-2 C5.51 2	V2 21301-001-15 21301-001-15 1301		ISI-21301-001 VALVE TO 28" PIPE (TS 5.5.16)	ISI AUG OWN PRE	-	-	-	-	-	-
C-F-2 C5.51 2	V2 21301-001-16 21301-001-16 1301		ISI-21301-001 28" PIPE TO PIPE FORGING (TS 5.5.16)	ISI AUG OWN PRE	-	-	-	-	-	-
C-F-2 C5.51 2	V2 21301-001-2 21301-001-2 1301		ISI-21301-001 28" PIPE TO PIPE (TS 5.5.16)	ISI AUG OWN PRE	-	-	-	-	-	-
C-F-2 C5.51 2	V2 21301-001-3 21301-001-3 1301		ISI-21301-001 28" PIPE TO PIPE (TS 5.5.16)	ISI AUG OWN PRE	-	-	-	-	-	-
C-F-2 C5.51 2	V2 21301-001-4 21301-001-4 1301	ISI/UT/NMP-ES-024-502	ISI-21301-001 28" PIPE TO 29 1/2" PIPE (TS 5.5.16)	ISI AUG OWN PRE	-	s	-	-	-	-

**Southern Nuclear Operating Company
3rd Interval
VOGTLE-2 ISI PLAN, VERSION 3.0**

Category, Item No., Class	Summary No./ComplD/System	Scope / Method / Procedure	Dwg/ISO No. Comp. Desc. Code Case		Period 1		Period 2			Period 3	
					2VR13	2VR14	2VR14A	2VR15	2VR16	2VR17	2VR18
C-F-2	V2 21301-001-5		ISI-21301-001	ISI	-	-	-	-	-	-	-
C5.51	21301-001-5		6" OUTLET TO FLANGE	AUG	-	-	-	-	-	-	-
2	1301			OWN	-	-	-	-	-	-	-
				PRE	-	-	-	-	-	-	-
C-F-2	V2 21301-001-6		ISI-21301-001	ISI	-	-	-	-	-	-	-
C5.51	21301-001-6		6" OUTLET TO FLANGE	AUG	-	-	-	-	-	-	-
2	1301			OWN	-	-	-	-	-	-	-
				PRE	-	-	-	-	-	-	-
C-F-2	V2 21301-001-7		ISI-21301-001	ISI	-	-	-	-	-	-	-
C5.51	21301-001-7		6" OUTLET TO FLANGE	AUG	-	-	-	-	-	-	-
2	1301			OWN	-	-	-	-	-	-	-
				PRE	-	-	-	-	-	-	-
C-F-2	V2 21301-001-8		ISI-21301-001	ISI	-	-	-	-	-	-	-
C5.51	21301-001-8		6" OUTLET TO FLANGE	AUG	-	-	-	-	-	-	-
2	1301			OWN	-	-	-	-	-	-	-
				PRE	-	-	-	-	-	-	-
C-F-2	V2 21301-002-1		ISI-21301-002	ISI	-	-	-	-	-	-	-
C5.51	21301-002-1		PENETRATION TO 28" PIPE (TS 5.5.16)	AUG	-	-	-	-	-	-	-
2	1301			OWN	-	-	-	-	-	-	-
				PRE	-	-	-	-	-	-	-
C-F-2	V2 21301-002-10		ISI-21301-002	ISI	-	-	-	-	-	-	-
C5.51	21301-002-10		29 1/2" PIPE TO VALVE (TS 5.5.16)	AUG	-	-	-	-	-	-	-
2	1301			OWN	-	-	-	-	-	-	-
				PRE	-	-	-	-	-	-	-
C-F-2	V2 21301-002-11		ISI-21301-002	ISI	-	-	-	-	-	-	-
C5.51	21301-002-11		VALVE TO 29 1/2" PIPE (TS 5.5.16)	AUG	-	-	-	-	-	-	-
2	1301			OWN	-	-	-	-	-	-	-
				PRE	-	-	-	-	-	-	-
C-F-2	V2 21301-002-13		ISI-21301-002	ISI	-	-	-	-	-	-	-
C5.51	21301-002-13		29 1/2" PIPE TO VALVE (TS 5.5.16)	AUG	-	-	-	-	-	-	-
2	1301			OWN	-	-	-	-	-	-	-
				PRE	-	-	-	-	-	-	-
C-F-2	V2 21301-002-14		ISI-21301-002	ISI	-	-	-	-	-	-	-
C5.51	21301-002-14		VALVE TO 28" PIPE (TS 5.5.16)	AUG	-	-	-	-	-	-	-
2	1301			OWN	-	-	-	-	-	-	-
				PRE	-	-	-	-	-	-	-
C-F-2	V2 21301-002-15		ISI-21301-002	ISI	-	-	-	-	-	-	-
C5.51	21301-002-15		28" PIPE TO PIPE FORGING (TS 5.5.16)	AUG	-	-	-	-	-	-	-
2	1301			OWN	-	-	-	-	-	-	-
				PRE	-	-	-	-	-	-	-

Southern Nuclear Operating Company
3rd Interval
VOGTLE-2 ISI PLAN, VERSION 3.0

Category, Item No., Class	Summary No./CompID/System	Scope / Method / Procedure	Dwg/ISO No. Comp. Desc. Code Case		Period 1		Period 2			Period 3	
					2VR13	2VR14	2VR14A	2VR15	2VR16	2VR17	2VR18
C-F-2 C5.51 2	V2 21301-002-2 21301-002-2 1301		ISI-21301-002 28" PIPE TO PIPE (TS 5.5.16)	ISI AUG OWN PRE	-	-	-	-	-	-	-
C-F-2 C5.51 2	V2 21301-002-3 21301-002-3 1301		ISI-21301-002 28" PIPE TO 29 1/2" PIPE (TS 5.5.16)	ISI AUG OWN PRE	-	-	-	-	-	-	-
C-F-2 C5.51 2	V2 21301-002-4 21301-002-4 1301		ISI-21301-002 6" OUTLET TO FLANGE	ISI AUG OWN PRE	-	-	-	-	-	-	-
C-F-2 C5.51 2	V2 21301-002-5 21301-002-5 1301		ISI-21301-002 6" OUTLET TO FLANGE	ISI AUG OWN PRE	-	-	-	-	-	-	-
C-F-2 C5.51 2	V2 21301-002-6 21301-002-6 1301		ISI-21301-002 6" OUTLET TO FLANGE	ISI AUG OWN PRE	-	-	-	-	-	-	-
C-F-2 C5.51 2	V2 21301-002-8 21301-002-8 1301		ISI-21301-002 6" OUTLET TO FLANGE	ISI AUG OWN PRE	-	-	-	-	-	-	-
C-F-2 C5.51 2	V2 21301-002-9 21301-002-9 1301		ISI-21301-002 6" OUTLET TO FLANGE	ISI AUG OWN PRE	-	-	-	-	-	-	-
C-F-2 C5.51 2	V2 21301-003-1 21301-003-1 1301		ISI-21301-003 PENETRATION TO 28" PIPE (TS 5.5.16)	ISI AUG OWN PRE	-	-	-	-	-	-	-
C-F-2 C5.51 2	V2 21301-003-10 21301-003-10 1301		ISI-21301-003 29 1/2" PIPE TO VALVE (TS 5.5.16)	ISI AUG OWN PRE	-	-	-	-	-	-	-
C-F-2 C5.51 2	V2 21301-003-11 21301-003-11 1301		ISI-21301-003 VALVE TO 29 1/2" PIPE (TS 5.5.16)	ISI AUG OWN PRE	-	-	-	-	-	-	-

Southern Nuclear Operating Company
3rd Interval
VOGTLE-2 ISI PLAN, VERSION 3.0

Category, Item No., Class	Summary No./CompID/System	Scope / Method / Procedure	Dwg/ISO No. Comp. Desc. Code Case		Period 1		Period 2			Period 3	
					2VR13	2VR14	2VR14A	2VR15	2VR16	2VR17	2VR18
C-F-2	V2 21301-003-13		ISI-21301-003	ISI	-	-	-	-	-	-	-
C5.51	21301-003-13		29 1/2" PIPE TO VALVE (TS 5.5.16)	AUG	-	-	-	-	-	-	-
2	1301			OWN	-	-	-	-	-	-	-
				PRE	-	-	-	-	-	-	-
C-F-2	V2 21301-003-14		ISI-21301-003	ISI	-	-	-	-	-	-	-
C5.51	21301-003-14		VALVE TO 28" PIPE (TS 5.5.16)	AUG	-	-	-	-	-	-	-
2	1301			OWN	-	-	-	-	-	-	-
				PRE	-	-	-	-	-	-	-
C-F-2	V2 21301-003-15		ISI-21301-003	ISI	-	-	-	-	-	-	-
C5.51	21301-003-15		28" PIPE TO PIPE FORGING (TS 5.5.16)	AUG	-	-	-	-	-	-	-
2	1301			OWN	-	-	-	-	-	-	-
				PRE	-	-	-	-	-	-	-
C-F-2	V2 21301-003-2		ISI-21301-003	ISI	-	-	-	-	-	-	-
C5.51	21301-003-2		28" PIPE TO PIPE (TS 5.5.16)	AUG	-	-	-	-	-	-	-
2	1301			OWN	-	-	-	-	-	-	-
				PRE	-	-	-	-	-	-	-
C-F-2	V2 21301-003-3		ISI-21301-003	ISI	-	-	-	-	-	-	-
C5.51	21301-003-3		28" PIPE TO 29 1/2" PIPE (TS 5.5.16)	AUG	-	-	-	-	-	-	-
2	1301			OWN	-	-	-	-	-	-	-
				PRE	-	-	-	-	-	-	-
C-F-2	V2 21301-003-4		ISI-21301-003	ISI	-	-	-	-	-	-	-
C5.51	21301-003-4		6" OUTLET TO FLANGE	AUG	-	-	-	-	-	-	-
2	1301			OWN	-	-	-	-	-	-	-
				PRE	-	-	-	-	-	-	-
C-F-2	V2 21301-003-5		ISI-21301-003	ISI	-	-	-	-	-	-	-
C5.51	21301-003-5		6" OUTLET TO FLANGE	AUG	-	-	-	-	-	-	-
2	1301			OWN	-	-	-	-	-	-	-
				PRE	-	-	-	-	-	-	-
C-F-2	V2 21301-003-6		ISI-21301-003	ISI	-	-	-	-	-	-	-
C5.51	21301-003-6		6" OUTLET TO FLANGE	AUG	-	-	-	-	-	-	-
2	1301			OWN	-	-	-	-	-	-	-
				PRE	-	-	-	-	-	-	-
C-F-2	V2 21301-003-8		ISI-21301-003	ISI	-	-	-	-	-	-	-
C5.51	21301-003-8		6" OUTLET TO FLANGE	AUG	-	-	-	-	-	-	-
2	1301			OWN	-	-	-	-	-	-	-
				PRE	-	-	-	-	-	-	-
C-F-2	V2 21301-003-9		ISI-21301-003	ISI	-	-	-	-	-	-	-
C5.51	21301-003-9		6" OUTLET TO FLANGE	AUG	-	-	-	-	-	-	-
2	1301			OWN	-	-	-	-	-	-	-
				PRE	-	-	-	-	-	-	-

Southern Nuclear Operating Company
3rd Interval
VOGTLE-2 ISI PLAN, VERSION 3.0

Category, Item No., Class	Summary No./CompID/System	Scope / Method / Procedure	Dwg/ISO No. Comp. Desc. Code Case		Period 1		Period 2		Period 3						
					2VR13	2VR14	2VR14A	2VR15	2VR16	2VR17	2VR18				
C-F-2 C5.51 2	V2 21301-004-1 21301-004-1 1301		ISI-21301-004 PENETRATION TO 28" PIPE (TS 5.5.16)	ISI AUG OWN PRE	-	-	-	-	-	-	-	-	-	-	-
C-F-2 C5.51 2	V2 21301-004-10 21301-004-10 1301		ISI-21301-004 29 1/2" PIPE TO VALVE (TS 5.5.16)	ISI AUG OWN PRE	-	-	-	-	-	-	-	-	-	-	-
C-F-2 C5.51 2	V2 21301-004-11 21301-004-11 1301		ISI-21301-004 VALVE TO 29 1/2" PIPE (TS 5.5.16)	ISI AUG OWN PRE	-	-	-	-	-	-	-	-	-	-	-
C-F-2 C5.51 2	V2 21301-004-13 21301-004-13 1301		ISI-21301-004 29 1/2" PIPE TO VALVE (TS 5.5.16)	ISI AUG OWN PRE	-	-	-	-	-	-	-	-	-	-	-
C-F-2 C5.51 2	V2 21301-004-14 21301-004-14 1301		ISI-21301-004 VALVE TO 28" PIPE (TS 5.5.16)	ISI AUG OWN PRE	-	-	-	-	-	-	-	-	-	-	-
C-F-2 C5.51 2	V2 21301-004-15 21301-004-15 1301		ISI-21301-004 28" PIPE TO PIPE FORGING (TS 5.5.16)	ISI AUG OWN PRE	-	-	-	-	-	-	-	-	-	-	-
C-F-2 C5.51 2	V2 21301-004-2 21301-004-2 1301		ISI-21301-004 28" PIPE TO PIPE (TS 5.5.16)	ISI AUG OWN PRE	-	-	-	-	-	-	-	-	-	-	-
C-F-2 C5.51 2	V2 21301-004-3 21301-004-3 1301		ISI-21301-004 28" PIPE TO 29 1/2" PIPE (TS 5.5.16)	ISI AUG OWN PRE	-	-	-	-	-	-	-	-	-	-	-
C-F-2 C5.51 2	V2 21301-004-4 21301-004-4 1301		ISI-21301-004 6" OUTLET TO FLANGE	ISI AUG OWN PRE	-	-	-	-	-	-	-	-	-	-	-
C-F-2 C5.51 2	V2 21301-004-5 21301-004-5 1301	ISI/UT/	ISI-21301-004 6" OUTLET TO FLANGE	ISI AUG OWN PRE	-	-	-	s	-	-	-	-	-	-	-

**Southern Nuclear Operating Company
3rd Interval
VOGTLE-2 ISI PLAN, VERSION 3.0**

Category, Item No., Class	Summary No./ComplD/System	Scope / Method / Procedure	Dwg/ISO No. Comp. Desc. Code Case		Period 1		Period 2			Period 3	
					2VR13	2VR14	2VR14A	2VR15	2VR16	2VR17	2VR18
C-F-2	V2 21301-004-6		ISI-21301-004	ISI	-	-	-	-	-	-	-
C5.51	21301-004-6		6" OUTLET TO FLANGE	AUG	-	-	-	-	-	-	-
2	1301			OWN	-	-	-	-	-	-	-
				PRE	-	-	-	-	-	-	-
C-F-2	V2 21301-004-7		ISI-21301-004	ISI	-	-	-	-	-	-	-
C5.51	21301-004-7		6" OUTLET TO FLANGE	AUG	-	-	-	-	-	-	-
2	1301			OWN	-	-	-	-	-	-	-
				PRE	-	-	-	-	-	-	-
C-F-2	V2 21301-004-9		ISI-21301-004	ISI	-	-	-	-	-	-	-
C5.51	21301-004-9		6" OUTLET TO FLANGE	AUG	-	-	-	-	-	-	-
2	1301			OWN	-	-	-	-	-	-	-
				PRE	-	-	-	-	-	-	-
C-F-2	V2 21301-013-1		ISI-21301-013	ISI	-	-	-	-	-	-	-
C5.51	21301-013-1		10" BRANCH CONNECTION TO PIPE	AUG	-	-	-	-	-	-	-
2	1301			OWN	-	-	-	-	-	-	-
				PRE	-	-	-	-	-	-	-
C-F-2	V2 21301-013-10		ISI-21301-013	ISI	-	-	-	-	-	-	-
C5.51	21301-013-10		8" PIPE TO VALVE	AUG	-	-	-	-	-	-	-
2	1301			OWN	-	-	-	-	-	-	-
				PRE	-	-	-	-	-	-	-
C-F-2	V2 21301-013-11		ISI-21301-013	ISI	-	-	-	-	-	-	-
C5.51	21301-013-11		8" VALVE TO PIPE	AUG	-	-	-	-	-	-	-
2	1301			OWN	-	-	-	-	-	-	-
				PRE	-	-	-	-	-	-	-
C-F-2	V2 21301-013-12		ISI-21301-013	ISI	-	-	-	-	-	-	-
C5.51	21301-013-12		8" PIPE TO VALVE	AUG	-	-	-	-	-	-	-
2	1301			OWN	-	-	-	-	-	-	-
				PRE	-	-	-	-	-	-	-
C-F-2	V2 21301-013-2		ISI-21301-013	ISI	-	-	-	-	-	-	-
C5.51	21301-013-2		10" PIPE TO REDUCER	AUG	-	-	-	-	-	-	-
2	1301			OWN	-	-	-	-	-	-	-
				PRE	-	-	-	-	-	-	-
C-F-2	V2 21301-013-3	ISI/UT/NMP-ES-024-502	ISI-21301-013	ISI	-	s	-	-	-	-	-
C5.51	21301-013-3		8" REDUCER TO PIPE	AUG	-	-	-	-	-	-	-
2	1301			OWN	-	-	-	-	-	-	-
				PRE	-	-	-	-	-	-	-
C-F-2	V2 21301-013-4		ISI-21301-013	ISI	-	-	-	-	-	-	-
C5.51	21301-013-4		8" PIPE TO ELBOW	AUG	-	-	-	-	-	-	-
2	1301			OWN	-	-	-	-	-	-	-
				PRE	-	-	-	-	-	-	-

Southern Nuclear Operating Company
3rd Interval
VOGTLE-2 ISI PLAN, VERSION 3.0

Category, Item No., Class	Summary No./CompID/System	Scope / Method / Procedure	Dwg/ISO No. Comp. Desc. Code Case		Period 1		Period 2		Period 3	
					2VR13	2VR14	2VR14A	2VR15	2VR16	2VR17
C-F-2	V2 21301-013-5		ISI-21301-013	ISI	-	-	-	-	-	-
C5.51	21301-013-5		8" ELBOW TO PIPE	AUG	-	-	-	-	-	-
2	1301			OWN	-	-	-	-	-	-
				PRE	-	-	-	-	-	-
C-F-2	V2 21301-013-6		ISI-21301-013	ISI	-	-	-	-	-	-
C5.51	21301-013-6		8" PIPE TO ELBOW	AUG	-	-	-	-	-	-
2	1301			OWN	-	-	-	-	-	-
				PRE	-	-	-	-	-	-
C-F-2	V2 21301-013-7		ISI-21301-013	ISI	-	-	-	-	-	-
C5.51	21301-013-7		8" ELBOW TO PIPE	AUG	-	-	-	-	-	-
2	1301			OWN	-	-	-	-	-	-
				PRE	-	-	-	-	-	-
C-F-2	V2 21301-013-8		ISI-21301-013	ISI	-	-	-	-	-	-
C5.51	21301-013-8		8" PIPE TO VALVE	AUG	-	-	-	-	-	-
2	1301			OWN	-	-	-	-	-	-
				PRE	-	-	-	-	-	-
C-F-2	V2 21301-013-9		ISI-21301-013	ISI	-	-	-	-	-	-
C5.51	21301-013-9		8" VALVE TO PIPE	AUG	-	-	-	-	-	-
2	1301			OWN	-	-	-	-	-	-
				PRE	-	-	-	-	-	-
C-F-2	V2 21301-014-1		ISI-21301-014	ISI	-	-	-	-	-	-
C5.51	21301-014-1		10" BRANCH CONNECTION TO PIPE	AUG	-	-	-	-	-	-
2	1301			OWN	-	-	-	-	-	-
				PRE	-	-	-	-	-	-
C-F-2	V2 21301-014-10		ISI-21301-014	ISI	-	-	-	-	-	-
C5.51	21301-014-10		8" PIPE TO VALVE	AUG	-	-	-	-	-	-
2	1301			OWN	-	-	-	-	-	-
				PRE	-	-	-	-	-	-
C-F-2	V2 21301-014-11		ISI-21301-014	ISI	-	-	-	-	-	-
C5.51	21301-014-11		8" VALVE TO PIPE	AUG	-	-	-	-	-	-
2	1301			OWN	-	-	-	-	-	-
				PRE	-	-	-	-	-	-
C-F-2	V2 21301-014-12		ISI-21301-014	ISI	-	-	-	-	-	-
C5.51	21301-014-12		8" PIPE TO VALVE	AUG	-	-	-	-	-	-
2	1301			OWN	-	-	-	-	-	-
				PRE	-	-	-	-	-	-
C-F-2	V2 21301-014-13		ISI-21301-014	ISI	-	-	-	-	-	-
C5.51	21301-014-13		8" VALVE TO PIPE	AUG	-	-	-	-	-	-
2	1301			OWN	-	-	-	-	-	-
				PRE	-	-	-	-	-	-

**Southern Nuclear Operating Company
3rd Interval
VOGTLE-2 ISI PLAN, VERSION 3.0**

Category, Item No., Class	Summary No./CompID/System	Scope / Method / Procedure	Dwg/ISO No. Comp. Desc. Code Case		Period 1		Period 2			Period 3	
					2VR13	2VR14	2VR14A	2VR15	2VR16	2VR17	2VR18
C-F-2 C5.51 2	V2 21301-014-14 21301-014-14 1301		ISI-21301-014 8" PIPE TO ELBOW	ISI AUG OWN PRE	-	-	-	-	-	-	-
C-F-2 C5.51 2	V2 21301-014-15 21301-014-15 1301		ISI-21301-014 8" ELBOW TO PIPE	ISI AUG OWN PRE	-	-	-	-	-	-	-
C-F-2 C5.51 2	V2 21301-014-16 21301-014-16 1301		ISI-21301-014 8" PIPE TO VALVE	ISI AUG OWN PRE	-	-	-	-	-	-	-
C-F-2 C5.51 2	V2 21301-014-2 21301-014-2 1301		ISI-21301-014 10" PIPE TO REDUCER	ISI AUG OWN PRE	-	-	-	-	-	-	-
C-F-2 C5.51 2	V2 21301-014-3 21301-014-3 1301	ISI/UT/	ISI-21301-014 8" REDUCER TO PIPE	ISI AUG OWN PRE	-	-	-	-	-	s	-
C-F-2 C5.51 2	V2 21301-014-4 21301-014-4 1301		ISI-21301-014 8" PIPE TO ELBOW	ISI AUG OWN PRE	-	-	-	-	-	-	-
C-F-2 C5.51 2	V2 21301-014-5 21301-014-5 1301		ISI-21301-014 8" ELBOW TO PIPE	ISI AUG OWN PRE	-	-	-	-	-	-	-
C-F-2 C5.51 2	V2 21301-014-6 21301-014-6 1301		ISI-21301-014 8" PIPE TO ELBOW	ISI AUG OWN PRE	-	-	-	-	-	-	-
C-F-2 C5.51 2	V2 21301-014-7 21301-014-7 1301		ISI-21301-014 8" ELBOW TO PIPE	ISI AUG OWN PRE	-	-	-	-	-	-	-
C-F-2 C5.51 2	V2 21301-014-8 21301-014-8 1301		ISI-21301-014 8" PIPE TO ELBOW	ISI AUG OWN PRE	-	-	-	-	-	-	-

**Southern Nuclear Operating Company
3rd Interval
VOGTLE-2 ISI PLAN, VERSION 3.0**

Category, Item No., Class	Summary No./CompID/System	Scope / Method / Procedure	Dwg/ISO No. Comp. Desc. Code Case		Period 1		Period 2			Period 3	
					2VR13	2VR14	2VR14A	2VR15	2VR16	2VR17	2VR18
C-F-2 C5.51 2	V2 21301-014-9 21301-014-9 1301		ISI-21301-014 8" ELBOW TO PIPE	ISI AUG OWN PRE	-	-	-	-	-	-	-
C-F-2 C5.51 2	V2 21301-015-1 21301-015-1 1301		ISI-21301-015 10" BRANCH CONNECTION TO PIPE	ISI AUG OWN PRE	-	-	-	-	-	-	-
C-F-2 C5.51 2	V2 21301-015-10 21301-015-10 1301		ISI-21301-015 8" PIPE TO ELBOW	ISI AUG OWN PRE	-	-	-	-	-	-	-
C-F-2 C5.51 2	V2 21301-015-11 21301-015-11 1301		ISI-21301-015 8" ELBOW TO PIPE	ISI AUG OWN PRE	-	-	-	-	-	-	-
C-F-2 C5.51 2	V2 21301-015-12 21301-015-12 1301		ISI-21301-015 8" PIPE TO VALVE	ISI AUG OWN PRE	-	-	-	-	-	-	-
C-F-2 C5.51 2	V2 21301-015-13 21301-015-13 1301		ISI-21301-015 8" VALVE TO PIPE	ISI AUG OWN PRE	-	-	-	-	-	-	-
C-F-2 C5.51 2	V2 21301-015-14 21301-015-14 1301		ISI-21301-015 8" PIPE TO VALVE	ISI AUG OWN PRE	-	-	-	-	-	-	-
C-F-2 C5.51 2	V2 21301-015-15 21301-015-15 1301		ISI-21301-015 8" VALVE TO PIPE	ISI AUG OWN PRE	-	-	-	-	-	-	-
C-F-2 C5.51 2	V2 21301-015-16 21301-015-16 1301		ISI-21301-015 8" PIPE TO VALVE	ISI AUG OWN PRE	-	-	-	-	-	-	-
C-F-2 C5.51 2	V2 21301-015-2 21301-015-2 1301		ISI-21301-015 10" PIPE TO REDUCER	ISI AUG OWN PRE	-	-	-	-	-	-	-

Southern Nuclear Operating Company
3rd Interval
VOGTLE-2 ISI PLAN, VERSION 3.0

Category, Item No., Class	Summary No./CompID/System	Scope / Method / Procedure	Dwg/ISO No. Comp. Desc. Code Case		Period 1		Period 2			Period 3		
					2VR13	2VR14	2VR14A	2VR15	2VR16	2VR17	2VR18	
C-F-2 C5.51 2	V2 21301-015-3 21301-015-3 1301	ISI/UT/	ISI-21301-015 8" REDUCER TO PIPE	ISI AUG OWN PRE	-	-	-	-	-	-	s	-
C-F-2 C5.51 2	V2 21301-015-4 21301-015-4 1301		ISI-21301-015 8" PIPE TO ELBOW	ISI AUG OWN PRE	-	-	-	-	-	-	-	-
C-F-2 C5.51 2	V2 21301-015-5 21301-015-5 1301		ISI-21301-015 8" ELBOW TO PIPE	ISI AUG OWN PRE	-	-	-	-	-	-	-	-
C-F-2 C5.51 2	V2 21301-015-6 21301-015-6 1301		ISI-21301-015 8" PIPE TO ELBOW	ISI AUG OWN PRE	-	-	-	-	-	-	-	-
C-F-2 C5.51 2	V2 21301-015-7 21301-015-7 1301		ISI-21301-015 8" ELBOW TO PIPE	ISI AUG OWN PRE	-	-	-	-	-	-	-	-
C-F-2 C5.51 2	V2 21301-015-8 21301-015-8 1301		ISI-21301-015 8" PIPE TO ELBOW	ISI AUG OWN PRE	-	-	-	-	-	-	-	-
C-F-2 C5.51 2	V2 21301-015-9 21301-015-9 1301	ISI/UT/	ISI-21301-015 8" ELBOW TO PIPE	ISI AUG OWN PRE	-	-	-	-	-	-	s	-
C-F-2 C5.51 2	V2 21301-016-1 21301-016-1 1301		ISI-21301-016 10" BRANCH CONNECTION TO PIPE	ISI AUG OWN PRE	-	-	-	-	-	-	-	-
C-F-2 C5.51 2	V2 21301-016-10 21301-016-10 1301		ISI-21301-016 8" PIPE TO VALVE	ISI AUG OWN PRE	-	-	-	-	-	-	-	-
C-F-2 C5.51 2	V2 21301-016-11 21301-016-11 1301		ISI-21301-016 8" VALVE TO PIPE	ISI AUG OWN PRE	-	-	-	-	-	-	-	-

**Southern Nuclear Operating Company
3rd Interval
VOGTLE-2 ISI PLAN, VERSION 3.0**

Category, Item No., Class	Summary No./ComplD/System	Scope / Method / Procedure	Dwg/ISO No. Comp. Desc. Code Case		Period 1		Period 2		Period 3	
					2VR13	2VR14	2VR14A	2VR15	2VR16	2VR17
C-F-2	V2 21301-016-13		ISI-21301-016	ISI	-	-	-	-	-	-
C5.51	21301-016-13		8" PIPE TO VALVE	AUG	-	-	-	-	-	-
2	1301			OWN	-	-	-	-	-	-
				PRE	-	-	-	-	-	-
C-F-2	V2 21301-016-2		ISI-21301-016	ISI	-	-	-	-	-	-
C5.51	21301-016-2		10" PIPE TO REDUCER	AUG	-	-	-	-	-	-
2	1301			OWN	-	-	-	-	-	-
				PRE	-	-	-	-	-	-
C-F-2	V2 21301-016-3		ISI-21301-016	ISI	-	-	-	-	-	-
C5.51	21301-016-3		8" REDUCER TO PIPE	AUG	-	-	-	-	-	-
2	1301			OWN	-	-	-	-	-	-
				PRE	-	-	-	-	-	-
C-F-2	V2 21301-016-4		ISI-21301-016	ISI	-	-	-	-	-	-
C5.51	21301-016-4		8" PIPE TO ELBOW	AUG	-	-	-	-	-	-
2	1301			OWN	-	-	-	-	-	-
				PRE	-	-	-	-	-	-
C-F-2	V2 21301-016-5		ISI-21301-016	ISI	-	-	-	-	-	-
C5.51	21301-016-5		8" ELBOW TO PIPE	AUG	-	-	-	-	-	-
2	1301			OWN	-	-	-	-	-	-
				PRE	-	-	-	-	-	-
C-F-2	V2 21301-016-6		ISI-21301-016	ISI	-	-	-	-	-	-
C5.51	21301-016-6		8" PIPE TO ELBOW	AUG	-	-	-	-	-	-
2	1301			OWN	-	-	-	-	-	-
				PRE	-	-	-	-	-	-
C-F-2	V2 21301-016-7		ISI-21301-016	ISI	-	-	-	-	-	-
C5.51	21301-016-7		8" ELBOW TO PIPE	AUG	-	-	-	-	-	-
2	1301			OWN	-	-	-	-	-	-
				PRE	-	-	-	-	-	-
C-F-2	V2 21301-016-8		ISI-21301-016	ISI	-	-	-	-	-	-
C5.51	21301-016-8		8" PIPE TO VALVE	AUG	-	-	-	-	-	-
2	1301			OWN	-	-	-	-	-	-
				PRE	-	-	-	-	-	-
C-F-2	V2 21301-016-9		ISI-21301-016	ISI	-	-	-	-	-	-
C5.51	21301-016-9		8" VALVE TO PIPE	AUG	-	-	-	-	-	-
2	1301			OWN	-	-	-	-	-	-
				PRE	-	-	-	-	-	-
C-F-2	V2 21301-104-1		ISI-21301-104	ISI	-	-	-	-	-	-
C5.51	21301-104-1		32" NOZZLE TO REDUCER	AUG	-	-	-	-	-	-
2	1301			OWN	-	-	-	-	-	-
				PRE	-	-	-	-	-	-

**Southern Nuclear Operating Company
3rd Interval
VOGTLE-2 ISI PLAN, VERSION 3.0**

Category, Item No., Class	Summary No./CompID/System	Scope / Method / Procedure	Dwg/ISO No. Comp. Desc. Code Case		Period 1		Period 2			Period 3	
					2VR13	2VR14	2VR14A	2VR15	2VR16	2VR17	2VR18
C-F-2 C5.51 2	V2 21301-104-10 21301-104-10 1301		ISI-21301-104 26" ELBOW TO PIPE	ISI AUG OWN PRE	-	-	-	-	-	-	-
C-F-2 C5.51 2	V2 21301-104-11 21301-104-11 1301		ISI-21301-104 26" PIPE TO ELBOW	ISI AUG OWN PRE	-	-	-	-	-	-	-
C-F-2 C5.51 2	V2 21301-104-12 21301-104-12 1301		ISI-21301-104 26" ELBOW TO PIPE	ISI AUG OWN PRE	-	-	-	-	-	-	-
C-F-2 C5.51 2	V2 21301-104-13 21301-104-13 1301	ISI/UT/	ISI-21301-104 26" PIPE TO PENETRATION	ISI AUG OWN PRE	-	-	-	s	-	-	-
C-F-2 C5.51 2	V2 21301-104-2 21301-104-2 1301		ISI-21301-104 26" REDUCER TO ELBOW	ISI AUG OWN PRE	-	-	-	-	-	-	-
C-F-2 C5.51 2	V2 21301-104-3 21301-104-3 1301		ISI-21301-104 26" ELBOW TO PIPE	ISI AUG OWN PRE	-	-	-	-	-	-	-
C-F-2 C5.51 2	V2 21301-104-4 21301-104-4 1301		ISI-21301-104 26" PIPE TO ELBOW	ISI AUG OWN PRE	-	-	-	-	-	-	-
C-F-2 C5.51 2	V2 21301-104-5 21301-104-5 1301		ISI-21301-104 26" ELBOW TO PIPE	ISI AUG OWN PRE	-	-	-	-	-	-	-
C-F-2 C5.51 2	V2 21301-104-7 21301-104-7 1301		ISI-21301-104 26" PIPE TO ELBOW	ISI AUG OWN PRE	-	-	-	-	-	-	-
C-F-2 C5.51 2	V2 21301-104-8 21301-104-8 1301		ISI-21301-104 26" ELBOW TO PIPE	ISI AUG OWN PRE	-	-	-	-	-	-	-

Southern Nuclear Operating Company
3rd Interval
VOGTLE-2 ISI PLAN, VERSION 3.0

Category, Item No., Class	Summary No./ComplD/System	Scope / Method / Procedure	Dwg/ISO No. Comp. Desc. Code Case		Period 1		Period 2			Period 3	
					2VR13	2VR14	2VR14A	2VR15	2VR16	2VR17	2VR18
C-F-2	V2 21301-104-9		ISI-21301-104	ISI	-	-	-	-	-	-	-
C5.51	21301-104-9		26" PIPE TO ELBOW	AUG	-	-	-	-	-	-	-
2	1301			OWN	-	-	-	-	-	-	-
				PRE	-	-	-	-	-	-	-
C-F-2	V2 21301-105-1		ISI-21301-105	ISI	-	-	-	-	-	-	-
C5.51	21301-105-1		32" NOZZLE TO REDUCER	AUG	-	-	-	-	-	-	-
2	1301			OWN	-	-	-	-	-	-	-
				PRE	-	-	-	-	-	-	-
C-F-2	V2 21301-105-10		ISI-21301-105	ISI	-	-	-	-	-	-	-
C5.51	21301-105-10		26" ELBOW TO PIPE	AUG	-	-	-	-	-	-	-
2	1301			OWN	-	-	-	-	-	-	-
				PRE	-	-	-	-	-	-	-
C-F-2	V2 21301-105-11		ISI-21301-105	ISI	-	-	-	-	-	-	-
C5.51	21301-105-11		26" PIPE TO ELBOW	AUG	-	-	-	-	-	-	-
2	1301			OWN	-	-	-	-	-	-	-
				PRE	-	-	-	-	-	-	-
C-F-2	V2 21301-105-12		ISI-21301-105	ISI	-	-	-	-	-	-	-
C5.51	21301-105-12		26" ELBOW TO PIPE	AUG	-	-	-	-	-	-	-
2	1301			OWN	-	-	-	-	-	-	-
				PRE	-	-	-	-	-	-	-
C-F-2	V2 21301-105-13		ISI-21301-105	ISI	-	-	-	-	-	-	-
C5.51	21301-105-13		26" PIPE TO PENETRATION	AUG	-	-	-	-	-	-	-
2	1301			OWN	-	-	-	-	-	-	-
				PRE	-	-	-	-	-	-	-
C-F-2	V2 21301-105-2		ISI-21301-105	ISI	-	-	-	-	-	-	-
C5.51	21301-105-2		26" REDUCER TO ELBOW	AUG	-	-	-	-	-	-	-
2	1301			OWN	-	-	-	-	-	-	-
				PRE	-	-	-	-	-	-	-
C-F-2	V2 21301-105-3		ISI-21301-105	ISI	-	-	-	-	-	-	-
C5.51	21301-105-3		26" ELBOW TO PIPE	AUG	-	-	-	-	-	-	-
2	1301			OWN	-	-	-	-	-	-	-
				PRE	-	-	-	-	-	-	-
C-F-2	V2 21301-105-4		ISI-21301-105	ISI	-	-	-	-	-	-	-
C5.51	21301-105-4		26" PIPE TO ELBOW	AUG	-	-	-	-	-	-	-
2	1301			OWN	-	-	-	-	-	-	-
				PRE	-	-	-	-	-	-	-
C-F-2	V2 21301-105-5		ISI-21301-105	ISI	-	-	-	-	-	-	-
C5.51	21301-105-5		26" ELBOW TO PIPE	AUG	-	-	-	-	-	-	-
2	1301			OWN	-	-	-	-	-	-	-
				PRE	-	-	-	-	-	-	-

Southern Nuclear Operating Company
3rd Interval
VOGTLE-2 ISI PLAN, VERSION 3.0

Category, Item No., Class	Summary No./ComplID/System	Scope / Method / Procedure	Dwg/ISO No. Comp. Desc. Code Case		Period 1		Period 2		Period 3	
					2VR13	2VR14	2VR14A	2VR15	2VR16	2VR17
C-F-2	V2 21301-105-7		ISI-21301-105	ISI	-	-	-	-	-	-
C5.51	21301-105-7		26" PIPE TO ELBOW	AUG	-	-	-	-	-	-
2	1301			OWN	-	-	-	-	-	-
				PRE	-	-	-	-	-	-
C-F-2	V2 21301-105-8		ISI-21301-105	ISI	-	-	-	-	-	-
C5.51	21301-105-8		26" ELBOW TO PIPE	AUG	-	-	-	-	-	-
2	1301			OWN	-	-	-	-	-	-
				PRE	-	-	-	-	-	-
C-F-2	V2 21301-105-9		ISI-21301-105	ISI	-	-	-	-	-	-
C5.51	21301-105-9		26" PIPE TO ELBOW	AUG	-	-	-	-	-	-
2	1301			OWN	-	-	-	-	-	-
				PRE	-	-	-	-	-	-
C-F-2	V2 21301-106-1		ISI-21301-106	ISI	-	-	-	-	-	-
C5.51	21301-106-1		32" NOZZLE TO REDUCER	AUG	-	-	-	-	-	-
2	1301			OWN	-	-	-	-	-	-
				PRE	-	-	-	-	-	-
C-F-2	V2 21301-106-10		ISI-21301-106	ISI	-	-	-	-	-	-
C5.51	21301-106-10		26" ELBOW TO PIPE	AUG	-	-	-	-	-	-
2	1301			OWN	-	-	-	-	-	-
				PRE	-	-	-	-	-	-
C-F-2	V2 21301-106-11		ISI-21301-106	ISI	-	-	-	-	-	-
C5.51	21301-106-11		26" PIPE TO ELBOW	AUG	-	-	-	-	-	-
2	1301			OWN	-	-	-	-	-	-
				PRE	-	-	-	-	-	-
C-F-2	V2 21301-106-12		ISI-21301-106	ISI	-	-	-	-	-	-
C5.51	21301-106-12		26" ELBOW TO PIPE	AUG	-	-	-	-	-	-
2	1301			OWN	-	-	-	-	-	-
				PRE	-	-	-	-	-	-
C-F-2	V2 21301-106-13	ISI/UT/	ISI-21301-106	ISI	-	-	-	s	-	-
C5.51	21301-106-13		26" PIPE TO PENETRATION	AUG	-	-	-	s	-	-
2	1301			OWN	-	-	-	-	-	-
				PRE	-	-	-	-	-	-
C-F-2	V2 21301-106-2		ISI-21301-106	ISI	-	-	-	-	-	-
C5.51	21301-106-2		26" REDUCER TO ELBOW	AUG	-	-	-	-	-	-
2	1301			OWN	-	-	-	-	-	-
				PRE	-	-	-	-	-	-
C-F-2	V2 21301-106-3		ISI-21301-106	ISI	-	-	-	-	-	-
C5.51	21301-106-3		26" ELBOW TO PIPE	AUG	-	-	-	-	-	-
2	1301			OWN	-	-	-	-	-	-
				PRE	-	-	-	-	-	-

Southern Nuclear Operating Company
3rd Interval
VOGTLE-2 ISI PLAN, VERSION 3.0

Category, Item No., Class	Summary No./ComplD/System	Scope / Method / Procedure	Dwg/ISO No. Comp. Desc. Code Case		Period 1		Period 2			Period 3	
					2VR13	2VR14	2VR14A	2VR15	2VR16	2VR17	2VR18
C-F-2	V2 21301-106-4		ISI-21301-106	ISI	-	-	-	-	-	-	-
C5.51	21301-106-4		26" PIPE TO ELBOW	AUG	-	-	-	-	-	-	-
2	1301			OWN	-	-	-	-	-	-	-
				PRE	-	-	-	-	-	-	-
C-F-2	V2 21301-106-5		ISI-21301-106	ISI	-	-	-	-	-	-	-
C5.51	21301-106-5		26" ELBOW TO PIPE	AUG	-	-	-	-	-	-	-
2	1301			OWN	-	-	-	-	-	-	-
				PRE	-	-	-	-	-	-	-
C-F-2	V2 21301-106-7		ISI-21301-106	ISI	-	-	-	-	-	-	-
C5.51	21301-106-7		26" PIPE TO ELBOW	AUG	-	-	-	-	-	-	-
2	1301			OWN	-	-	-	-	-	-	-
				PRE	-	-	-	-	-	-	-
C-F-2	V2 21301-106-8		ISI-21301-106	ISI	-	-	-	-	-	-	-
C5.51	21301-106-8		26" ELBOW TO PIPE	AUG	-	-	-	-	-	-	-
2	1301			OWN	-	-	-	-	-	-	-
				PRE	-	-	-	-	-	-	-
C-F-2	V2 21301-106-9		ISI-21301-106	ISI	-	-	-	-	-	-	-
C5.51	21301-106-9		26" PIPE TO ELBOW	AUG	-	-	-	-	-	-	-
2	1301			OWN	-	-	-	-	-	-	-
				PRE	-	-	-	-	-	-	-
C-F-2	V2 21301-107-1		ISI-21301-107	ISI	-	-	-	-	-	-	-
C5.51	21301-107-1		32" NOZZLE TO REDUCER	AUG	-	-	-	-	-	-	-
2	1301			OWN	-	-	-	-	-	-	-
				PRE	-	-	-	-	-	-	-
C-F-2	V2 21301-107-10		ISI-21301-107	ISI	-	-	-	-	-	-	-
C5.51	21301-107-10		26" ELBOW TO PIPE	AUG	-	-	-	-	-	-	-
2	1301			OWN	-	-	-	-	-	-	-
				PRE	-	-	-	-	-	-	-
C-F-2	V2 21301-107-11		ISI-21301-107	ISI	-	-	-	-	-	-	-
C5.51	21301-107-11		26" PIPE TO ELBOW	AUG	-	-	-	-	-	-	-
2	1301			OWN	-	-	-	-	-	-	-
				PRE	-	-	-	-	-	-	-
C-F-2	V2 21301-107-12		ISI-21301-107	ISI	-	-	-	-	-	-	-
C5.51	21301-107-12		26" ELBOW TO PIPE	AUG	-	-	-	-	-	-	-
2	1301			OWN	-	-	-	-	-	-	-
				PRE	-	-	-	-	-	-	-
C-F-2	V2 21301-107-13	ISI/UT/NMP-ES-024-502	ISI-21301-107	ISI	-	s	-	-	-	-	-
C5.51	21301-107-13		26" PIPE TO PENETRATION	AUG	-	-	-	-	-	-	-
2	1301			OWN	-	-	-	-	-	-	-
				PRE	-	-	-	-	-	-	-

**Southern Nuclear Operating Company
3rd Interval
VOGTLE-2 ISI PLAN, VERSION 3.0**

Category, Item No., Class	Summary No./ComplD/System	Scope / Method / Procedure	Dwg/ISO No. Comp. Desc. Code Case		Period 1		Period 2			Period 3	
					2VR13	2VR14	2VR14A	2VR15	2VR16	2VR17	2VR18
C-F-2	V2 21301-107-2		ISI-21301-107	ISI	-	-	-	-	-	-	-
C5.51	21301-107-2		26" REDUCER TO ELBOW	AUG	-	-	-	-	-	-	-
2	1301			OWN	-	-	-	-	-	-	-
				PRE	-	-	-	-	-	-	-
C-F-2	V2 21301-107-3		ISI-21301-107	ISI	-	-	-	-	-	-	-
C5.51	21301-107-3		26" ELBOW TO PIPE	AUG	-	-	-	-	-	-	-
2	1301			OWN	-	-	-	-	-	-	-
				PRE	-	-	-	-	-	-	-
C-F-2	V2 21301-107-3 A		ISI-21301-107	ISI	-	-	-	-	-	-	-
C5.51	21301-107-3 A		26" PIPE TO PIPE	AUG	-	-	-	-	-	-	-
2	1301			OWN	-	-	-	-	-	-	-
				PRE	-	-	-	-	-	-	-
C-F-2	V2 21301-107-3 B		ISI-21301-107	ISI	-	-	-	-	-	-	-
C5.51	21301-107-3 B		26" PIPE TO PIPE	AUG	-	-	-	-	-	-	-
2	1301			OWN	-	-	-	-	-	-	-
				PRE	-	-	-	-	-	-	-
C-F-2	V2 21301-107-4		ISI-21301-107	ISI	-	-	-	-	-	-	-
C5.51	21301-107-4		26" PIPE TO ELBOW	AUG	-	-	-	-	-	-	-
2	1301			OWN	-	-	-	-	-	-	-
				PRE	-	-	-	-	-	-	-
C-F-2	V2 21301-107-5		ISI-21301-107	ISI	-	-	-	-	-	-	-
C5.51	21301-107-5		26" ELBOW TO PIPE	AUG	-	-	-	-	-	-	-
2	1301			OWN	-	-	-	-	-	-	-
				PRE	-	-	-	-	-	-	-
C-F-2	V2 21301-107-7		ISI-21301-107	ISI	-	-	-	-	-	-	-
C5.51	21301-107-7		26" PIPE TO ELBOW	AUG	-	-	-	-	-	-	-
2	1301			OWN	-	-	-	-	-	-	-
				PRE	-	-	-	-	-	-	-
C-F-2	V2 21301-107-8		ISI-21301-107	ISI	-	-	-	-	-	-	-
C5.51	21301-107-8		26" ELBOW TO PIPE	AUG	-	-	-	-	-	-	-
2	1301			OWN	-	-	-	-	-	-	-
				PRE	-	-	-	-	-	-	-
C-F-2	V2 21301-107-9		ISI-21301-107	ISI	-	-	-	-	-	-	-
C5.51	21301-107-9		26" PIPE TO ELBOW	AUG	-	-	-	-	-	-	-
2	1301			OWN	-	-	-	-	-	-	-
				PRE	-	-	-	-	-	-	-
C-F-2	V2 21302-107-1		ISI-21302-107	ISI	-	-	-	-	-	-	-
C5.51	21302-107-1		6" VALVE TO PIPE	AUG	-	-	-	-	-	-	-
2	1302			OWN	-	-	-	-	-	-	-
				PRE	-	-	-	-	-	-	-

**Southern Nuclear Operating Company
3rd Interval
VOGTLE-2 ISI PLAN, VERSION 3.0**

Category, Item No., Class	Summary No./CompID/System	Scope / Method / Procedure	Dwg/ISO No. Comp. Desc. Code Case		Period 1		Period 2			Period 3	
					2VR13	2VR14	2VR14A	2VR15	2VR16	2VR17	2VR18
C-F-2 C5.51 2	V2 21302-107-10 21302-107-10 1302		ISI-21302-107 6" PIPE TO TEE	ISI AUG OWN PRE	-	-	-	-	-	-	-
C-F-2 C5.51 2	V2 21302-107-11 21302-107-11 1302		ISI-21302-107 6" TEE TO PIPE	ISI AUG OWN PRE	-	-	-	-	-	-	-
C-F-2 C5.51 2	V2 21302-107-12 21302-107-12 1302	ISI/UT/	ISI-21302-107 6" PIPE TO PENETRATION	ISI AUG OWN PRE	-	-	-	s	-	-	-
C-F-2 C5.51 2	V2 21302-107-13 21302-107-13 1302	ISI/UT/	ISI-21302-107 PENETRATION TO 6" PIPE	ISI AUG OWN PRE	-	-	-	s	-	-	-
C-F-2 C5.51 2	V2 21302-107-14 21302-107-14 1302	ISI/UT/	ISI-21302-107 6" PIPE TO VALVE	ISI AUG OWN PRE	-	-	-	s	-	-	-
C-F-2 C5.51 2	V2 21302-107-15 21302-107-15 1302	ISI/UT/	ISI-21302-107 6" VALVE TO PIPE	ISI AUG OWN PRE	-	-	-	s	-	-	-
C-F-2 C5.51 2	V2 21302-107-16 21302-107-16 1302		ISI-21302-107 6" PIPE TO ELBOW	ISI AUG OWN PRE	-	-	-	-	-	-	-
C-F-2 C5.51 2	V2 21302-107-17 21302-107-17 1302		ISI-21302-107 6" ELBOW TO PIPE	ISI AUG OWN PRE	-	-	-	-	-	-	-
C-F-2 C5.51 2	V2 21302-107-18 21302-107-18 1302		ISI-21302-107 6" PIPE TO ELBOW	ISI AUG OWN PRE	-	-	-	-	-	-	-
C-F-2 C5.51 2	V2 21302-107-19 21302-107-19 1302		ISI-21302-107 6" ELBOW TO PIPE	ISI AUG OWN PRE	-	-	-	-	-	-	-

**Southern Nuclear Operating Company
3rd Interval
VOGTLE-2 ISI PLAN, VERSION 3.0**

Category, Item No., Class	Summary No./CompID/System	Scope / Method / Procedure	Dwg/ISO No. Comp. Desc. Code Case		Period 1		Period 2			Period 3	
					2VR13	2VR14	2VR14A	2VR15	2VR16	2VR17	2VR18
C-F-2 C5.51 2	V2 21302-107-2 21302-107-2 1302		ISI-21302-107 6" PIPE TO ELBOW	ISI AUG OWN PRE	-	-	-	-	-	-	-
C-F-2 C5.51 2	V2 21302-107-20 21302-107-20 1302		ISI-21302-107 6" PIPE TO ELBOW	ISI AUG OWN PRE	-	-	-	-	-	-	-
C-F-2 C5.51 2	V2 21302-107-21 21302-107-21 1302		ISI-21302-107 6" ELBOW TO PIPE	ISI AUG OWN PRE	-	-	-	-	-	-	-
C-F-2 C5.51 2	V2 21302-107-22 21302-107-22 1302		ISI-21302-107 6" PIPE TO ELBOW	ISI AUG OWN PRE	-	-	-	-	-	-	-
C-F-2 C5.51 2	V2 21302-107-23 21302-107-23 1302		ISI-21302-107 6" ELBOW TO PIPE	ISI AUG OWN PRE	-	-	-	-	-	-	-
C-F-2 C5.51 2	V2 21302-107-25 21302-107-25 1302		ISI-21302-107 6" PIPE TO PIPE	ISI AUG OWN PRE	-	-	-	-	-	-	-
C-F-2 C5.51 2	V2 21302-107-26 21302-107-26 1302		ISI-21302-107 6" PIPE TO ELBOW	ISI AUG OWN PRE	-	-	-	-	-	-	-
C-F-2 C5.51 2	V2 21302-107-27 21302-107-27 1302		ISI-21302-107 6" ELBOW TO PIPE	ISI AUG OWN PRE	-	-	-	-	-	-	-
C-F-2 C5.51 2	V2 21302-107-28 21302-107-28 1302		ISI-21302-107 6" PIPE TO ELBOW	ISI AUG OWN PRE	-	-	-	-	-	-	-
C-F-2 C5.51 2	V2 21302-107-29 21302-107-29 1302		ISI-21302-107 6" ELBOW TO PIPE	ISI AUG OWN PRE	-	-	-	-	-	-	-

Southern Nuclear Operating Company
3rd Interval
VOGTLE-2 ISI PLAN, VERSION 3.0

Category, Item No., Class	Summary No./CompID/System	Scope / Method / Procedure	Dwg/ISO No. Comp. Desc. Code Case		Period 1		Period 2			Period 3	
					2VR13	2VR14	2VR14A	2VR15	2VR16	2VR17	2VR18
C-F-2	V2 21302-107-3		ISI-21302-107	ISI	-	-	-	-	-	-	-
C5.51	21302-107-3		6" ELBOW TO PIPE	AUG	-	-	-	-	-	-	-
2	1302			OWN	-	-	-	-	-	-	-
				PRE	-	-	-	-	-	-	-
C-F-2	V2 21302-107-30		ISI-21302-107	ISI	-	-	-	-	-	-	-
C5.51	21302-107-30		6" PIPE TO PIPE	AUG	-	-	-	-	-	-	-
2	1302			OWN	-	-	-	-	-	-	-
				PRE	-	-	-	-	-	-	-
C-F-2	V2 21302-107-31		ISI-21302-107	ISI	-	-	-	-	-	-	-
C5.51	21302-107-31		6" PIPE TO ELBOW	AUG	-	-	-	-	-	-	-
2	1302			OWN	-	-	-	-	-	-	-
				PRE	-	-	-	-	-	-	-
C-F-2	V2 21302-107-32		ISI-21302-107	ISI	-	-	-	-	-	-	-
C5.51	21302-107-32		6" ELBOW TO PIPE	AUG	-	-	-	-	-	-	-
2	1302			OWN	-	-	-	-	-	-	-
				PRE	-	-	-	-	-	-	-
C-F-2	V2 21302-107-33		ISI-21302-107	ISI	-	-	-	-	-	-	-
C5.51	21302-107-33		6" PIPE TO ELBOW	AUG	-	-	-	-	-	-	-
2	1302			OWN	-	-	-	-	-	-	-
				PRE	-	-	-	-	-	-	-
C-F-2	V2 21302-107-34		ISI-21302-107	ISI	-	-	-	-	-	-	-
C5.51	21302-107-34		6" ELBOW TO PIPE	AUG	-	-	-	-	-	-	-
2	1302			OWN	-	-	-	-	-	-	-
				PRE	-	-	-	-	-	-	-
C-F-2	V2 21302-107-35		ISI-21302-107	ISI	-	-	-	-	-	-	-
C5.51	21302-107-35		6" PIPE TO PIPE	AUG	-	-	-	-	-	-	-
2	1302			OWN	-	-	-	-	-	-	-
				PRE	-	-	-	-	-	-	-
C-F-2	V2 21302-107-36		ISI-21302-107	ISI	-	-	-	-	-	-	-
C5.51	21302-107-36		6" PIPE TO ELBOW	AUG	-	-	-	-	-	-	-
2	1302			OWN	-	-	-	-	-	-	-
				PRE	-	-	-	-	-	-	-
C-F-2	V2 21302-107-37		ISI-21302-107	ISI	-	-	-	-	-	-	-
C5.51	21302-107-37		6" ELBOW TO PIPE	AUG	-	-	-	-	-	-	-
2	1302			OWN	-	-	-	-	-	-	-
				PRE	-	-	-	-	-	-	-
C-F-2	V2 21302-107-38		ISI-21302-107	ISI	-	-	-	-	-	-	-
C5.51	21302-107-38		6" PIPE TO ELBOW	AUG	-	-	-	-	-	-	-
2	1302			OWN	-	-	-	-	-	-	-
				PRE	-	-	-	-	-	-	-

Southern Nuclear Operating Company
3rd Interval
VOGTLE-2 ISI PLAN, VERSION 3.0

Category, Item No., Class	Summary No./ComplID/System	Scope / Method / Procedure	Dwg/ISO No. Comp. Desc. Code Case		Period 1		Period 2		Period 3	
					2VR13	2VR14	2VR14A	2VR15	2VR16	2VR17
C-F-2	V2 21302-107-39		ISI-21302-107	ISI	-	-	-	-	-	-
C5.51	21302-107-39		6" ELBOW TO PIPE	AUG	-	-	-	-	-	-
2	1302			OWN	-	-	-	-	-	-
				PRE	-	-	-	-	-	-
C-F-2	V2 21302-107-4		ISI-21302-107	ISI	-	-	-	-	-	-
C5.51	21302-107-4		6" PIPE TO ELBOW	AUG	-	-	-	-	-	-
2	1302			OWN	-	-	-	-	-	-
				PRE	-	-	-	-	-	-
C-F-2	V2 21302-107-40		ISI-21302-107	ISI	-	-	-	-	-	-
C5.51	21302-107-40		6" PIPE TO ELBOW	AUG	-	-	-	-	-	-
2	1302			OWN	-	-	-	-	-	-
				PRE	-	-	-	-	-	-
C-F-2	V2 21302-107-41		ISI-21302-107	ISI	-	-	-	-	-	-
C5.51	21302-107-41		6" ELBOW TO PIPE	AUG	-	-	-	-	-	-
2	1302			OWN	-	-	-	-	-	-
				PRE	-	-	-	-	-	-
C-F-2	V2 21302-107-42		ISI-21302-107	ISI	-	-	-	-	-	-
C5.51	21302-107-42		6" PIPE TO ELBOW	AUG	-	-	-	-	-	-
2	1302			OWN	-	-	-	-	-	-
				PRE	-	-	-	-	-	-
C-F-2	V2 21302-107-43		ISI-21302-107	ISI	-	-	-	-	-	-
C5.51	21302-107-43		6" ELBOW TO PIPE	AUG	-	-	-	-	-	-
2	1302			OWN	-	-	-	-	-	-
				PRE	-	-	-	-	-	-
C-F-2	V2 21302-107-44		ISI-21302-107	ISI	-	-	-	-	-	-
C5.51	21302-107-44		6" PIPE TO ELBOW	AUG	-	-	-	-	-	-
2	1302			OWN	-	-	-	-	-	-
				PRE	-	-	-	-	-	-
C-F-2	V2 21302-107-45		ISI-21302-107	ISI	-	-	-	-	-	-
C5.51	21302-107-45		6" ELBOW TO PIPE	AUG	-	-	-	-	-	-
2	1302			OWN	-	-	-	-	-	-
				PRE	-	-	-	-	-	-
C-F-2	V2 21302-107-46		ISI-21302-107	ISI	-	-	-	-	-	-
C5.51	21302-107-46		6" PIPE TO ELBOW	AUG	-	-	-	-	-	-
2	1302			OWN	-	-	-	-	-	-
				PRE	-	-	-	-	-	-
C-F-2	V2 21302-107-47		ISI-21302-107	ISI	-	-	-	-	-	-
C5.51	21302-107-47		6" ELBOW TO TRANSITION PIECE	AUG	-	-	-	-	-	-
2	1302			OWN	-	-	-	-	-	-
				PRE	-	-	-	-	-	-

**Southern Nuclear Operating Company
3rd Interval
VOGTLE-2 ISI PLAN, VERSION 3.0**

Category, Item No., Class	Summary No./CompID/System	Scope / Method / Procedure	Dwg/ISO No. Comp. Desc. Code Case		Period 1		Period 2		Period 3	
					2VR13	2VR14	2VR14A	2VR15	2VR16	2VR17
C-F-2 C5.51 2	V2 21302-107-48 21302-107-48 1302	ISI/UT/	ISI-21302-107 TRANSITION PIECE TO NOZZLE	ISI AUG OWN PRE	-	-	-	s	-	-
C-F-2 C5.51 2	V2 21302-107-5 21302-107-5 1302		ISI-21302-107 6" ELBOW TO PIPE	ISI AUG OWN PRE	-	-	-	-	-	-
C-F-2 C5.51 2	V2 21302-107-6 21302-107-6 1302	ISI/UT/NMP-ES-024-502	ISI-21302-107 6" PIPE TO ELBOW	ISI AUG OWN PRE	s	-	-	-	-	-
C-F-2 C5.51 2	V2 21302-107-7 21302-107-7 1302		ISI-21302-107 6" ELBOW TO PIPE	ISI AUG OWN PRE	-	-	-	-	-	-
C-F-2 C5.51 2	V2 21302-107-8 21302-107-8 1302		ISI-21302-107 6" PIPE TO VALVE	ISI AUG OWN PRE	-	-	-	-	-	-
C-F-2 C5.51 2	V2 21302-107-9 21302-107-9 1302		ISI-21302-107 6" VALVE TO PIPE	ISI AUG OWN PRE	-	-	-	-	-	-
C-F-2 C5.51 2	V2 21302-108-1 21302-108-1 1302		ISI-21302-108 6" VALVE TO PIPE	ISI AUG OWN PRE	-	-	-	-	-	-
C-F-2 C5.51 2	V2 21302-108-10 21302-108-10 1302		ISI-21302-108 6" PIPE TO ELBOW	ISI AUG OWN PRE	-	-	-	-	-	-
C-F-2 C5.51 2	V2 21302-108-11 21302-108-11 1302		ISI-21302-108 6" ELBOW TO PIPE	ISI AUG OWN PRE	-	-	-	-	-	-
C-F-2 C5.51 2	V2 21302-108-12 21302-108-12 1302		ISI-21302-108 6" PIPE TO TEE	ISI AUG OWN PRE	-	-	-	-	-	-

Southern Nuclear Operating Company
3rd Interval
VOGTLE-2 ISI PLAN, VERSION 3.0

Category, Item No., Class	Summary No./CompID/System	Scope / Method / Procedure	Dwg/ISO No. Comp. Desc. Code Case		Period 1		Period 2			Period 3	
					2VR13	2VR14	2VR14A	2VR15	2VR16	2VR17	2VR18
C-F-2 C5.51 2	V2 21302-108-13 21302-108-13 1302		ISI-21302-108 6" TEE TO PIPE	ISI AUG OWN PRE	-	-	-	-	-	-	-
C-F-2 C5.51 2	V2 21302-108-14 21302-108-14 1302	ISI/UT/	ISI-21302-108 6" PIPE TO PENETRATION	ISI AUG OWN PRE	-	-	-	-	-	s	-
C-F-2 C5.51 2	V2 21302-108-15 21302-108-15 1302	ISI/UT/	ISI-21302-108 PENETRATION TO 6" PIPE	ISI AUG OWN PRE	-	-	-	-	-	s	-
C-F-2 C5.51 2	V2 21302-108-16 21302-108-16 1302		ISI-21302-108 6" PIPE TO VALVE	ISI AUG OWN PRE	-	-	-	-	-	-	-
C-F-2 C5.51 2	V2 21302-108-17 21302-108-17 1302		ISI-21302-108 6" VALVE TO PIPE	ISI AUG OWN PRE	-	-	-	-	-	-	-
C-F-2 C5.51 2	V2 21302-108-18 21302-108-18 1302		ISI-21302-108 6" PIPE TO ELBOW	ISI AUG OWN PRE	-	-	-	-	-	-	-
C-F-2 C5.51 2	V2 21302-108-19 21302-108-19 1302		ISI-21302-108 6" ELBOW TO PIPE	ISI AUG OWN PRE	-	-	-	-	-	-	-
C-F-2 C5.51 2	V2 21302-108-2 21302-108-2 1302		ISI-21302-108 6" PIPE TO VALVE	ISI AUG OWN PRE	-	-	-	-	-	-	-
C-F-2 C5.51 2	V2 21302-108-20 21302-108-20 1302		ISI-21302-108 6" PIPE TO ELBOW	ISI AUG OWN PRE	-	-	-	-	-	-	-
C-F-2 C5.51 2	V2 21302-108-21 21302-108-21 1302		ISI-21302-108 6" ELBOW TO PIPE	ISI AUG OWN PRE	-	-	-	-	-	-	-

Southern Nuclear Operating Company
3rd Interval
VOGTLE-2 ISI PLAN, VERSION 3.0

Category, Item No., Class	Summary No./CompID/System	Scope / Method / Procedure	Dwg/ISO No. Comp. Desc. Code Case		Period 1		Period 2			Period 3	
					2VR13	2VR14	2VR14A	2VR15	2VR16	2VR17	2VR18
C-F-2	V2 21302-108-21 A		ISI-21302-108	ISI	-	-	-	-	-	-	-
C5.51	21302-108-21 A		6" PIPE TO ELBOW	AUG	-	-	-	-	-	-	-
2	1302			OWN	-	-	-	-	-	-	-
				PRE	-	-	-	-	-	-	-
C-F-2	V2 21302-108-21 B		ISI-21302-108	ISI	-	-	-	-	-	-	-
C5.51	21302-108-21 B		6" ELBOW TO PIPE	AUG	-	-	-	-	-	-	-
2	1302			OWN	-	-	-	-	-	-	-
				PRE	-	-	-	-	-	-	-
C-F-2	V2 21302-108-21 C		ISI-21302-108	ISI	-	-	-	-	-	-	-
C5.51	21302-108-21 C		6" PIPE TO ELBOW	AUG	-	-	-	-	-	-	-
2	1302			OWN	-	-	-	-	-	-	-
				PRE	-	-	-	-	-	-	-
C-F-2	V2 21302-108-21 D		ISI-21302-108	ISI	-	-	-	-	-	-	-
C5.51	21302-108-21 D		6" ELBOW TO PIPE	AUG	-	-	-	-	-	-	-
2	1302			OWN	-	-	-	-	-	-	-
				PRE	-	-	-	-	-	-	-
C-F-2	V2 21302-108-22		ISI-21302-108	ISI	-	-	-	-	-	-	-
C5.51	21302-108-22		6" PIPE TO ELBOW	AUG	-	-	-	-	-	-	-
2	1302			OWN	-	-	-	-	-	-	-
				PRE	-	-	-	-	-	-	-
C-F-2	V2 21302-108-23		ISI-21302-108	ISI	-	-	-	-	-	-	-
C5.51	21302-108-23		6" PIPE TO PIPE	AUG	-	-	-	-	-	-	-
2	1302			OWN	-	-	-	-	-	-	-
				PRE	-	-	-	-	-	-	-
C-F-2	V2 21302-108-23 A		ISI-21302-108	ISI	-	-	-	-	-	-	-
C5.51	21302-108-23 A		6" PIPE TO PIPE	AUG	-	-	-	-	-	-	-
2	1302			OWN	-	-	-	-	-	-	-
				PRE	-	-	-	-	-	-	-
C-F-2	V2 21302-108-24		ISI-21302-108	ISI	-	-	-	-	-	-	-
C5.51	21302-108-24		6" PIPE TO ELBOW	AUG	-	-	-	-	-	-	-
2	1302			OWN	-	-	-	-	-	-	-
				PRE	-	-	-	-	-	-	-
C-F-2	V2 21302-108-25		ISI-21302-108	ISI	-	-	-	-	-	-	-
C5.51	21302-108-25		6" ELBOW TO PIPE	AUG	-	-	-	-	-	-	-
2	1302			OWN	-	-	-	-	-	-	-
				PRE	-	-	-	-	-	-	-
C-F-2	V2 21302-108-26		ISI-21302-108	ISI	-	-	-	-	-	-	-
C5.51	21302-108-26		6" PIPE TO ELBOW	AUG	-	-	-	-	-	-	-
2	1302			OWN	-	-	-	-	-	-	-
				PRE	-	-	-	-	-	-	-

Southern Nuclear Operating Company
3rd Interval
VOGTLE-2 ISI PLAN, VERSION 3.0

Category, Item No., Class	Summary No./ComplID/System	Scope / Method / Procedure	Dwg/ISO No. Comp. Desc. Code Case		Period 1		Period 2			Period 3	
					2VR13	2VR14	2VR14A	2VR15	2VR16	2VR17	2VR18
C-F-2	V2 21302-108-27		ISI-21302-108	ISI	-	-	-	-	-	-	-
C5.51	21302-108-27		6" ELBOW TO PIPE	AUG	-	-	-	-	-	-	-
2	1302			OWN	-	-	-	-	-	-	-
				PRE	-	-	-	-	-	-	-
C-F-2	V2 21302-108-28		ISI-21302-108	ISI	-	-	-	-	-	-	-
C5.51	21302-108-28		6" PIPE TO ELBOW	AUG	-	-	-	-	-	-	-
2	1302			OWN	-	-	-	-	-	-	-
				PRE	-	-	-	-	-	-	-
C-F-2	V2 21302-108-29		ISI-21302-108	ISI	-	-	-	-	-	-	-
C5.51	21302-108-29		6" ELBOW TO PIPE	AUG	-	-	-	-	-	-	-
2	1302			OWN	-	-	-	-	-	-	-
				PRE	-	-	-	-	-	-	-
C-F-2	V2 21302-108-3		ISI-21302-108	ISI	-	-	-	-	-	-	-
C5.51	21302-108-3		6" VALVE TO PIPE	AUG	-	-	-	-	-	-	-
2	1302			OWN	-	-	-	-	-	-	-
				PRE	-	-	-	-	-	-	-
C-F-2	V2 21302-108-30		ISI-21302-108	ISI	-	-	-	-	-	-	-
C5.51	21302-108-30		6" PIPE TO PIPE	AUG	-	-	-	-	-	-	-
2	1302			OWN	-	-	-	-	-	-	-
				PRE	-	-	-	-	-	-	-
C-F-2	V2 21302-108-30 A		ISI-21302-108	ISI	-	-	-	-	-	-	-
C5.51	21302-108-30 A		6" PIPE TO PIPE	AUG	-	-	-	-	-	-	-
2	1302			OWN	-	-	-	-	-	-	-
				PRE	-	-	-	-	-	-	-
C-F-2	V2 21302-108-31		ISI-21302-108	ISI	-	-	-	-	-	-	-
C5.51	21302-108-31		6" PIPE TO ELBOW	AUG	-	-	-	-	-	-	-
2	1302			OWN	-	-	-	-	-	-	-
				PRE	-	-	-	-	-	-	-
C-F-2	V2 21302-108-32		ISI-21302-108	ISI	-	-	-	-	-	-	-
C5.51	21302-108-32		6" ELBOW TO PIPE	AUG	-	-	-	-	-	-	-
2	1302			OWN	-	-	-	-	-	-	-
				PRE	-	-	-	-	-	-	-
C-F-2	V2 21302-108-33		ISI-21302-108	ISI	-	-	-	-	-	-	-
C5.51	21302-108-33		6" PIPE TO ELBOW	AUG	-	-	-	-	-	-	-
2	1302			OWN	-	-	-	-	-	-	-
				PRE	-	-	-	-	-	-	-
C-F-2	V2 21302-108-34		ISI-21302-108	ISI	-	-	-	-	-	-	-
C5.51	21302-108-34		6" ELBOW TO PIPE	AUG	-	-	-	-	-	-	-
2	1302			OWN	-	-	-	-	-	-	-
				PRE	-	-	-	-	-	-	-

Southern Nuclear Operating Company
3rd Interval
VOGTLE-2 ISI PLAN, VERSION 3.0

Category, Item No., Class	Summary No./ComplID/System	Scope / Method / Procedure	Dwg/ISO No. Comp. Desc. Code Case	Period 1		Period 2			Period 3	
				2VR13	2VR14	2VR14A	2VR15	2VR16	2VR17	2VR18
C-F-2 C5.51 2	V2 21302-108-35 21302-108-35 1302		ISI-21302-108 6" PIPE TO ELBOW	ISI AUG OWN PRE	- - - -	- - - -	- - - -	- - - -	- - - -	- - - -
C-F-2 C5.51 2	V2 21302-108-36 21302-108-36 1302		ISI-21302-108 6" ELBOW TO PIPE	ISI AUG OWN PRE	- - - -	- - - -	- - - -	- - - -	- - - -	- - - -
C-F-2 C5.51 2	V2 21302-108-37 21302-108-37 1302		ISI-21302-108 6" PIPE TO ELBOW	ISI AUG OWN PRE	- - - -	- - - -	- - - -	- - - -	- - - -	- - - -
C-F-2 C5.51 2	V2 21302-108-38 21302-108-38 1302		ISI-21302-108 6" ELBOW TO PIPE	ISI AUG OWN PRE	- - - -	- - - -	- - - -	- - - -	- - - -	- - - -
C-F-2 C5.51 2	V2 21302-108-39 21302-108-39 1302		ISI-21302-108 6" PIPE TO ELBOW	ISI AUG OWN PRE	- - - -	- - - -	- - - -	- - - -	- - - -	- - - -
C-F-2 C5.51 2	V2 21302-108-4 21302-108-4 1302		ISI-21302-108 6" PIPE TO ELBOW	ISI AUG OWN PRE	- - - -	- - - -	- - - -	- - - -	- - - -	- - - -
C-F-2 C5.51 2	V2 21302-108-40 21302-108-40 1302		ISI-21302-108 6" ELBOW TO PIPE	ISI AUG OWN PRE	- - - -	- - - -	- - - -	- - - -	- - - -	- - - -
C-F-2 C5.51 2	V2 21302-108-41 21302-108-41 1302		ISI-21302-108 6" PIPE TO ELBOW	ISI AUG OWN PRE	- - - -	- - - -	- - - -	- - - -	- - - -	- - - -
C-F-2 C5.51 2	V2 21302-108-42 21302-108-42 1302		ISI-21302-108 6" ELBOW TO TRANSITION PIECE	ISI AUG OWN PRE	- - - -	- - - -	- - - -	- - - -	- - - -	- - - -
C-F-2 C5.51 2	V2 21302-108-43 21302-108-43 1302		ISI-21302-108 TRANSITION PIECE TO NOZZLE	ISI AUG OWN PRE	- - - -	- - - -	- - - -	- - - -	- - - -	- - - -

**Southern Nuclear Operating Company
3rd Interval
VOGTLE-2 ISI PLAN, VERSION 3.0**

Category, Item No., Class	Summary No./ComplD/System	Scope / Method / Procedure	Dwg/ISO No. Comp. Desc. Code Case		Period 1		Period 2		Period 3	
					2VR13	2VR14	2VR14A	2VR15	2VR16	2VR17
C-F-2	V2 21302-108-5		ISI-21302-108	ISI	-	-	-	-	-	-
C5.51	21302-108-5		6" ELBOW TO PIPE	AUG	-	-	-	-	-	-
2	1302			OWN	-	-	-	-	-	-
				PRE	-	-	-	-	-	-
C-F-2	V2 21302-108-6		ISI-21302-108	ISI	-	-	-	-	-	-
C5.51	21302-108-6		6" PIPE TO ELBOW	AUG	-	-	-	-	-	-
2	1302			OWN	-	-	-	-	-	-
				PRE	-	-	-	-	-	-
C-F-2	V2 21302-108-7		ISI-21302-108	ISI	-	-	-	-	-	-
C5.51	21302-108-7		6" ELBOW TO PIPE	AUG	-	-	-	-	-	-
2	1302			OWN	-	-	-	-	-	-
				PRE	-	-	-	-	-	-
C-F-2	V2 21302-108-8		ISI-21302-108	ISI	-	-	-	-	-	-
C5.51	21302-108-8		6" PIPE TO ELBOW	AUG	-	-	-	-	-	-
2	1302			OWN	-	-	-	-	-	-
				PRE	-	-	-	-	-	-
C-F-2	V2 21302-108-9		ISI-21302-108	ISI	-	-	-	-	-	-
C5.51	21302-108-9		6" ELBOW TO PIPE	AUG	-	-	-	-	-	-
2	1302			OWN	-	-	-	-	-	-
				PRE	-	-	-	-	-	-
C-F-2	V2 21302-109-1		ISI-21302-109	ISI	-	-	-	-	-	-
C5.51	21302-109-1		6" VALVE TO PIPE	AUG	-	-	-	-	-	-
2	1302			OWN	-	-	-	-	-	-
				PRE	-	-	-	-	-	-
C-F-2	V2 21302-109-10		ISI-21302-109	ISI	-	-	-	-	-	-
C5.51	21302-109-10		6" PIPE TO ELBOW	AUG	-	-	-	-	-	-
2	1302			OWN	-	-	-	-	-	-
				PRE	-	-	-	-	-	-
C-F-2	V2 21302-109-11		ISI-21302-109	ISI	-	-	-	-	-	-
C5.51	21302-109-11		6" ELBOW TO PIPE	AUG	-	-	-	-	-	-
2	1302			OWN	-	-	-	-	-	-
				PRE	-	-	-	-	-	-
C-F-2	V2 21302-109-12		ISI-21302-109	ISI	-	-	-	-	-	-
C5.51	21302-109-12		6" PIPE TO TEE	AUG	-	-	-	-	-	-
2	1302			OWN	-	-	-	-	-	-
				PRE	-	-	-	-	-	-
C-F-2	V2 21302-109-13		ISI-21302-109	ISI	-	-	-	-	-	-
C5.51	21302-109-13		6" TEE TO PIPE	AUG	-	-	-	-	-	-
2	1302			OWN	-	-	-	-	-	-
				PRE	-	-	-	-	-	-

Southern Nuclear Operating Company
3rd Interval
VOGTLE-2 ISI PLAN, VERSION 3.0

Category, Item No., Class	Summary No./ComplID/System	Scope / Method / Procedure	Dwg/ISO No. Comp. Desc. Code Case		Period 1		Period 2			Period 3	
					2VR13	2VR14	2VR14A	2VR15	2VR16	2VR17	2VR18
C-F-2	V2 21302-109-14		ISI-21302-109	ISI	-	-	-	-	-	-	-
C5.51	21302-109-14		6" PIPE TO PENETRATION	AUG	-	-	-	-	-	-	-
2	1302			OWN	-	-	-	-	-	-	-
				PRE	-	-	-	-	-	-	-
C-F-2	V2 21302-109-15	ISI/UT/	ISI-21302-109	ISI	-	-	-	s	-	-	-
C5.51	21302-109-15		PENETRATION TO 6" PIPE	AUG	-	-	-	-	-	-	-
2	1302			OWN	-	-	-	-	-	-	-
				PRE	-	-	-	-	-	-	-
C-F-2	V2 21302-109-16		ISI-21302-109	ISI	-	-	-	-	-	-	-
C5.51	21302-109-16		6" PIPE TO ELBOW	AUG	-	-	-	-	-	-	-
2	1302			OWN	-	-	-	-	-	-	-
				PRE	-	-	-	-	-	-	-
C-F-2	V2 21302-109-17		ISI-21302-109	ISI	-	-	-	-	-	-	-
C5.51	21302-109-17		6" ELBOW TO PIPE	AUG	-	-	-	-	-	-	-
2	1302			OWN	-	-	-	-	-	-	-
				PRE	-	-	-	-	-	-	-
C-F-2	V2 21302-109-18		ISI-21302-109	ISI	-	-	-	-	-	-	-
C5.51	21302-109-18		6" PIPE TO VALVE	AUG	-	-	-	-	-	-	-
2	1302			OWN	-	-	-	-	-	-	-
				PRE	-	-	-	-	-	-	-
C-F-2	V2 21302-109-19		ISI-21302-109	ISI	-	-	-	-	-	-	-
C5.51	21302-109-19		6" VALVE TO PIPE	AUG	-	-	-	-	-	-	-
2	1302			OWN	-	-	-	-	-	-	-
				PRE	-	-	-	-	-	-	-
C-F-2	V2 21302-109-2		ISI-21302-109	ISI	-	-	-	-	-	-	-
C5.51	21302-109-2		6" PIPE TO VALVE	AUG	-	-	-	-	-	-	-
2	1302			OWN	-	-	-	-	-	-	-
				PRE	-	-	-	-	-	-	-
C-F-2	V2 21302-109-20		ISI-21302-109	ISI	-	-	-	-	-	-	-
C5.51	21302-109-20		6" PIPE TO ELBOW	AUG	-	-	-	-	-	-	-
2	1302			OWN	-	-	-	-	-	-	-
				PRE	-	-	-	-	-	-	-
C-F-2	V2 21302-109-21		ISI-21302-109	ISI	-	-	-	-	-	-	-
C5.51	21302-109-21		6" ELBOW TO PIPE	AUG	-	-	-	-	-	-	-
2	1302			OWN	-	-	-	-	-	-	-
				PRE	-	-	-	-	-	-	-
C-F-2	V2 21302-109-22		ISI-21302-109	ISI	-	-	-	-	-	-	-
C5.51	21302-109-22		6" PIPE TO ELBOW	AUG	-	-	-	-	-	-	-
2	1302			OWN	-	-	-	-	-	-	-
				PRE	-	-	-	-	-	-	-

**Southern Nuclear Operating Company
3rd Interval
VOGTLE-2 ISI PLAN, VERSION 3.0**

Category, Item No., Class	Summary No./CompID/System	Scope / Method / Procedure	Dwg/ISO No. Comp. Desc. Code Case		Period 1		Period 2			Period 3	
					2VR13	2VR14	2VR14A	2VR15	2VR16	2VR17	2VR18
C-F-2 C5.51 2	V2 21302-109-23 21302-109-23 1302		ISI-21302-109 6" ELBOW TO PIPE	ISI AUG OWN PRE	-	-	-	-	-	-	-
C-F-2 C5.51 2	V2 21302-109-24 21302-109-24 1302		ISI-21302-109 6" PIPE TO ELBOW	ISI AUG OWN PRE	-	-	-	-	-	-	-
C-F-2 C5.51 2	V2 21302-109-25 21302-109-25 1302		ISI-21302-109 6" ELBOW TO PIPE	ISI AUG OWN PRE	-	-	-	-	-	-	-
C-F-2 C5.51 2	V2 21302-109-26 21302-109-26 1302		ISI-21302-109 6" PIPE TO ELBOW	ISI AUG OWN PRE	-	-	-	-	-	-	-
C-F-2 C5.51 2	V2 21302-109-27 21302-109-27 1302		ISI-21302-109 6" ELBOW TO PIPE	ISI AUG OWN PRE	-	-	-	-	-	-	-
C-F-2 C5.51 2	V2 21302-109-28 21302-109-28 1302		ISI-21302-109 6" PIPE TO ELBOW	ISI AUG OWN PRE	-	-	-	-	-	-	-
C-F-2 C5.51 2	V2 21302-109-29 21302-109-29 1302		ISI-21302-109 6" ELBOW TO PIPE	ISI AUG OWN PRE	-	-	-	-	-	-	-
C-F-2 C5.51 2	V2 21302-109-3 21302-109-3 1302		ISI-21302-109 6" VALVE TO PIPE	ISI AUG OWN PRE	-	-	-	-	-	-	-
C-F-2 C5.51 2	V2 21302-109-30 21302-109-30 1302		ISI-21302-109 6" PIPE TO PIPE	ISI AUG OWN PRE	-	-	-	-	-	-	-
C-F-2 C5.51 2	V2 21302-109-31 21302-109-31 1302		ISI-21302-109 6" PIPE TO PIPE	ISI AUG OWN PRE	-	-	-	-	-	-	-

Southern Nuclear Operating Company
3rd Interval
VOGTLE-2 ISI PLAN, VERSION 3.0

Category, Item No., Class	Summary No./ComplD/System	Scope / Method / Procedure	Dwg/ISO No. Comp. Desc. Code Case		Period 1		Period 2		Period 3	
					2VR13	2VR14	2VR14A	2VR15	2VR16	2VR17
C-F-2	V2 21302-109-32		ISI-21302-109	ISI	-	-	-	-	-	-
C5.51	21302-109-32		6" PIPE TO ELBOW	AUG	-	-	-	-	-	-
2	1302			OWN	-	-	-	-	-	-
				PRE	-	-	-	-	-	-
C-F-2	V2 21302-109-33		ISI-21302-109	ISI	-	-	-	-	-	-
C5.51	21302-109-33		6" ELBOW TO PIPE	AUG	-	-	-	-	-	-
2	1302			OWN	-	-	-	-	-	-
				PRE	-	-	-	-	-	-
C-F-2	V2 21302-109-34		ISI-21302-109	ISI	-	-	-	-	-	-
C5.51	21302-109-34		6" PIPE TO ELBOW	AUG	-	-	-	-	-	-
2	1302			OWN	-	-	-	-	-	-
				PRE	-	-	-	-	-	-
C-F-2	V2 21302-109-35		ISI-21302-109	ISI	-	-	-	-	-	-
C5.51	21302-109-35		6" ELBOW TO PIPE	AUG	-	-	-	-	-	-
2	1302			OWN	-	-	-	-	-	-
				PRE	-	-	-	-	-	-
C-F-2	V2 21302-109-36		ISI-21302-109	ISI	-	-	-	-	-	-
C5.51	21302-109-36		6" PIPE TO ELBOW	AUG	-	-	-	-	-	-
2	1302			OWN	-	-	-	-	-	-
				PRE	-	-	-	-	-	-
C-F-2	V2 21302-109-37		ISI-21302-109	ISI	-	-	-	-	-	-
C5.51	21302-109-37		6" ELBOW TO PIPE	AUG	-	-	-	-	-	-
2	1302			OWN	-	-	-	-	-	-
				PRE	-	-	-	-	-	-
C-F-2	V2 21302-109-38		ISI-21302-109	ISI	-	-	-	-	-	-
C5.51	21302-109-38		6" PIPE TO ELBOW	AUG	-	-	-	-	-	-
2	1302			OWN	-	-	-	-	-	-
				PRE	-	-	-	-	-	-
C-F-2	V2 21302-109-39		ISI-21302-109	ISI	-	-	-	-	-	-
C5.51	21302-109-39		6" ELBOW TO PIPE	AUG	-	-	-	-	-	-
2	1302			OWN	-	-	-	-	-	-
				PRE	-	-	-	-	-	-
C-F-2	V2 21302-109-4		ISI-21302-109	ISI	-	-	-	-	-	-
C5.51	21302-109-4		6" PIPE TO PIPE	AUG	-	-	-	-	-	-
2	1302			OWN	-	-	-	-	-	-
				PRE	-	-	-	-	-	-
C-F-2	V2 21302-109-40		ISI-21302-109	ISI	-	-	-	-	-	-
C5.51	21302-109-40		6" PIPE TO ELBOW	AUG	-	-	-	-	-	-
2	1302			OWN	-	-	-	-	-	-
				PRE	-	-	-	-	-	-

**Southern Nuclear Operating Company
3rd Interval
VOGTLE-2 ISI PLAN, VERSION 3.0**

Category, Item No., Class	Summary No./ComplD/System	Scope / Method / Procedure	Dwg/ISO No. Comp. Desc. Code Case		Period 1		Period 2			Period 3	
					2VR13	2VR14	2VR14A	2VR15	2VR16	2VR17	2VR18
C-F-2	V2 21302-109-41		ISI-21302-109	ISI	-	-	-	-	-	-	-
C5.51	21302-109-41		6" ELBOW TO PIPE	AUG	-	-	-	-	-	-	-
2	1302			OWN	-	-	-	-	-	-	-
				PRE	-	-	-	-	-	-	-
C-F-2	V2 21302-109-42		ISI-21302-109	ISI	-	-	-	-	-	-	-
C5.51	21302-109-42		6" PIPE TO ELBOW	AUG	-	-	-	-	-	-	-
2	1302			OWN	-	-	-	-	-	-	-
				PRE	-	-	-	-	-	-	-
C-F-2	V2 21302-109-43	ISI/UT/NMP-ES-024-502	ISI-21302-109	ISI	-	s	-	-	-	-	-
C5.51	21302-109-43		6" ELBOW TO TRANSITION PIECE	AUG	-	-	-	-	-	-	-
2	1302			OWN	-	-	-	-	-	-	-
				PRE	-	-	-	-	-	-	-
C-F-2	V2 21302-109-44	ISI/UT/NMP-ES-024-502	ISI-21302-109	ISI	-	s	-	-	-	-	-
C5.51	21302-109-44		TRANSITION PIECE TO NOZZLE	AUG	-	-	-	-	-	-	-
2	1302			OWN	-	-	-	-	-	-	-
				PRE	-	-	-	-	-	-	-
C-F-2	V2 21302-109-5		ISI-21302-109	ISI	-	-	-	-	-	-	-
C5.51	21302-109-5		6" PIPE TO ELBOW	AUG	-	-	-	-	-	-	-
2	1302			OWN	-	-	-	-	-	-	-
				PRE	-	-	-	-	-	-	-
C-F-2	V2 21302-109-6		ISI-21302-109	ISI	-	-	-	-	-	-	-
C5.51	21302-109-6		6" ELBOW TO PIPE	AUG	-	-	-	-	-	-	-
2	1302			OWN	-	-	-	-	-	-	-
				PRE	-	-	-	-	-	-	-
C-F-2	V2 21302-109-8		ISI-21302-109	ISI	-	-	-	-	-	-	-
C5.51	21302-109-8		6" PIPE TO ELBOW	AUG	-	-	-	-	-	-	-
2	1302			OWN	-	-	-	-	-	-	-
				PRE	-	-	-	-	-	-	-
C-F-2	V2 21302-109-9		ISI-21302-109	ISI	-	-	-	-	-	-	-
C5.51	21302-109-9		6" ELBOW TO PIPE	AUG	-	-	-	-	-	-	-
2	1302			OWN	-	-	-	-	-	-	-
				PRE	-	-	-	-	-	-	-
C-F-2	V2 21302-110-1		ISI-21302-110	ISI	-	-	-	-	-	-	-
C5.51	21302-110-1		6" VALVE TO PIPE	AUG	-	-	-	-	-	-	-
2	1302			OWN	-	-	-	-	-	-	-
				PRE	-	-	-	-	-	-	-
C-F-2	V2 21302-110-10		ISI-21302-110	ISI	-	-	-	-	-	-	-
C5.51	21302-110-10		6" PIPE TO ELBOW	AUG	-	-	-	-	-	-	-
2	1302			OWN	-	-	-	-	-	-	-
				PRE	-	-	-	-	-	-	-

**Southern Nuclear Operating Company
3rd Interval
VOGTLE-2 ISI PLAN, VERSION 3.0**

Category, Item No., Class	Summary No./CompID/System	Scope / Method / Procedure	Dwg/ISO No. Comp. Desc. Code Case		Period 1		Period 2			Period 3	
					2VR13	2VR14	2VR14A	2VR15	2VR16	2VR17	2VR18
C-F-2 C5.51 2	V2 21302-110-11 21302-110-11 1302		ISI-21302-110 6" ELBOW TO PIPE	ISI AUG OWN PRE	-	-	-	-	-	-	-
C-F-2 C5.51 2	V2 21302-110-12 21302-110-12 1302		ISI-21302-110 6" PIPE TO TEE	ISI AUG OWN PRE	-	-	-	-	-	-	-
C-F-2 C5.51 2	V2 21302-110-13 21302-110-13 1302		ISI-21302-110 6" TEE TO PIPE	ISI AUG OWN PRE	-	-	-	-	-	-	-
C-F-2 C5.51 2	V2 21302-110-14 21302-110-14 1302	ISI/UT/	ISI-21302-110 6" PIPE TO PENETRATION	ISI AUG OWN PRE	-	-	-	-	-	s	-
C-F-2 C5.51 2	V2 21302-110-15 21302-110-15 1302	ISI/UT/	ISI-21302-110 PENETRATION TO 6" PIPE	ISI AUG OWN PRE	-	-	-	-	-	s	-
C-F-2 C5.51 2	V2 21302-110-16 21302-110-16 1302		ISI-21302-110 6" PIPE TO VALVE	ISI AUG OWN PRE	-	-	-	-	-	-	-
C-F-2 C5.51 2	V2 21302-110-17 21302-110-17 1302		ISI-21302-110 6" VALVE TO PIPE	ISI AUG OWN PRE	-	-	-	-	-	-	-
C-F-2 C5.51 2	V2 21302-110-18 21302-110-18 1302		ISI-21302-110 6" PIPE TO ELBOW	ISI AUG OWN PRE	-	-	-	-	-	-	-
C-F-2 C5.51 2	V2 21302-110-19 21302-110-19 1302		ISI-21302-110 6" ELBOW TO PIPE	ISI AUG OWN PRE	-	-	-	-	-	-	-
C-F-2 C5.51 2	V2 21302-110-2 21302-110-2 1302		ISI-21302-110 6" PIPE TO VALVE	ISI AUG OWN PRE	-	-	-	-	-	-	-

Southern Nuclear Operating Company
3rd Interval
VOGTLE-2 ISI PLAN, VERSION 3.0

Category, Item No., Class	Summary No./CompID/System	Scope / Method / Procedure	Dwg/ISO No. Comp. Desc. Code Case		Period 1		Period 2			Period 3	
					2VR13	2VR14	2VR14A	2VR15	2VR16	2VR17	2VR18
C-F-2 C5.51 2	V2 21302-110-20 21302-110-20 1302		ISI-21302-110 6" PIPE TO ELBOW	ISI AUG OWN PRE	-	-	-	-	-	-	-
C-F-2 C5.51 2	V2 21302-110-21 21302-110-21 1302		ISI-21302-110 6" ELBOW TO PIPE	ISI AUG OWN PRE	-	-	-	-	-	-	-
C-F-2 C5.51 2	V2 21302-110-22 21302-110-22 1302		ISI-21302-110 6" PIPE TO ELBOW	ISI AUG OWN PRE	-	-	-	-	-	-	-
C-F-2 C5.51 2	V2 21302-110-23 21302-110-23 1302		ISI-21302-110 6" ELBOW TO PIPE	ISI AUG OWN PRE	-	-	-	-	-	-	-
C-F-2 C5.51 2	V2 21302-110-24 21302-110-24 1302		ISI-21302-110 6" PIPE TO ELBOW	ISI AUG OWN PRE	-	-	-	-	-	-	-
C-F-2 C5.51 2	V2 21302-110-25 21302-110-25 1302		ISI-21302-110 6" ELBOW TO PIPE	ISI AUG OWN PRE	-	-	-	-	-	-	-
C-F-2 C5.51 2	V2 21302-110-26 21302-110-26 1302		ISI-21302-110 6" PIPE TO ELBOW	ISI AUG OWN PRE	-	-	-	-	-	-	-
C-F-2 C5.51 2	V2 21302-110-27 21302-110-27 1302		ISI-21302-110 6" ELBOW TO PIPE	ISI AUG OWN PRE	-	-	-	-	-	-	-
C-F-2 C5.51 2	V2 21302-110-28 21302-110-28 1302		ISI-21302-110 6" PIPE TO ELBOW	ISI AUG OWN PRE	-	-	-	-	-	-	-
C-F-2 C5.51 2	V2 21302-110-29 21302-110-29 1302		ISI-21302-110 6" ELBOW TO PIPE	ISI AUG OWN PRE	-	-	-	-	-	-	-

**Southern Nuclear Operating Company
3rd Interval
VOGTLE-2 ISI PLAN, VERSION 3.0**

Category, Item No., Class	Summary No./ComplD/System	Scope / Method / Procedure	Dwg/ISO No. Comp. Desc. Code Case		Period 1		Period 2			Period 3	
					2VR13	2VR14	2VR14A	2VR15	2VR16	2VR17	2VR18
C-F-2 C5.51 2	V2 21302-110-3 21302-110-3 1302		ISI-21302-110 6" VALVE TO PIPE	ISI AUG OWN PRE	-	-	-	-	-	-	-
C-F-2 C5.51 2	V2 21302-110-30 21302-110-30 1302		ISI-21302-110 6" PIPE TO PIPE	ISI AUG OWN PRE	-	-	-	-	-	-	-
C-F-2 C5.51 2	V2 21302-110-31 21302-110-31 1302		ISI-21302-110 6" PIPE TO ELBOW	ISI AUG OWN PRE	-	-	-	-	-	-	-
C-F-2 C5.51 2	V2 21302-110-32 21302-110-32 1302		ISI-21302-110 6" ELBOW TO PIPE	ISI AUG OWN PRE	-	-	-	-	-	-	-
C-F-2 C5.51 2	V2 21302-110-33 21302-110-33 1302		ISI-21302-110 6" PIPE TO ELBOW	ISI AUG OWN PRE	-	-	-	-	-	-	-
C-F-2 C5.51 2	V2 21302-110-34 21302-110-34 1302		ISI-21302-110 6" ELBOW TO PIPE	ISI AUG OWN PRE	-	-	-	-	-	-	-
C-F-2 C5.51 2	V2 21302-110-35 21302-110-35 1302		ISI-21302-110 6" PIPE TO ELBOW	ISI AUG OWN PRE	-	-	-	-	-	-	-
C-F-2 C5.51 2	V2 21302-110-36 21302-110-36 1302		ISI-21302-110 6" ELBOW TO PIPE	ISI AUG OWN PRE	-	-	-	-	-	-	-
C-F-2 C5.51 2	V2 21302-110-37 21302-110-37 1302		ISI-21302-110 6" PIPE TO ELBOW	ISI AUG OWN PRE	-	-	-	-	-	-	-
C-F-2 C5.51 2	V2 21302-110-38 21302-110-38 1302		ISI-21302-110 6" ELBOW TO PIPE	ISI AUG OWN PRE	-	-	-	-	-	-	-

Southern Nuclear Operating Company
3rd Interval
VOGTLE-2 ISI PLAN, VERSION 3.0

Category, Item No., Class	Summary No./ComplD/System	Scope / Method / Procedure	Dwg/ISO No. Comp. Desc. Code Case	Period 1		Period 2			Period 3	
				2VR13	2VR14	2VR14A	2VR15	2VR16	2VR17	2VR18
C-F-2 C5.51 2	V2 21302-110-39 21302-110-39 1302		ISI-21302-110 6" PIPE TO ELBOW	ISI AUG OWN PRE	- - - -	- - - -	- - - -	- - - -	- - - -	- - - -
C-F-2 C5.51 2	V2 21302-110-4 21302-110-4 1302		ISI-21302-110 6" PIPE TO ELBOW	ISI AUG OWN PRE	- - - -	- - - -	- - - -	- - - -	- - - -	- - - -
C-F-2 C5.51 2	V2 21302-110-40 21302-110-40 1302		ISI-21302-110 6" ELBOW TO PIPE	ISI AUG OWN PRE	- - - -	- - - -	- - - -	- - - -	- - - -	- - - -
C-F-2 C5.51 2	V2 21302-110-41 21302-110-41 1302		ISI-21302-110 6" PIPE TO ELBOW	ISI AUG OWN PRE	- - - -	- - - -	- - - -	- - - -	- - - -	- - - -
C-F-2 C5.51 2	V2 21302-110-42 21302-110-42 1302		ISI-21302-110 6" ELBOW TO TRANSITION PIECE	ISI AUG OWN PRE	- - - -	- - - -	- - - -	- - - -	- - - -	- - - -
C-F-2 C5.51 2	V2 21302-110-43 21302-110-43 1302	ISI/UT/	ISI-21302-110 TRANSITION PIECE TO NOZZLE	ISI AUG OWN PRE	- - - -	- - - -	- - - -	s - - -	- - - -	- - - -
C-F-2 C5.51 2	V2 21302-110-5 21302-110-5 1302		ISI-21302-110 6" ELBOW TO PIPE	ISI AUG OWN PRE	- - - -	- - - -	- - - -	- - - -	- - - -	- - - -
C-F-2 C5.51 2	V2 21302-110-6 21302-110-6 1302		ISI-21302-110 6" PIPE TO ELBOW	ISI AUG OWN PRE	- - - -	- - - -	- - - -	- - - -	- - - -	- - - -
C-F-2 C5.51 2	V2 21302-110-7 21302-110-7 1302		ISI-21302-110 6" ELBOW TO PIPE	ISI AUG OWN PRE	- - - -	- - - -	- - - -	- - - -	- - - -	- - - -
C-F-2 C5.51 2	V2 21302-110-8 21302-110-8 1302		ISI-21302-110 6" PIPE TO ELBOW	ISI AUG OWN PRE	- - - -	- - - -	- - - -	- - - -	- - - -	- - - -

Southern Nuclear Operating Company
3rd Interval
VOGTLE-2 ISI PLAN, VERSION 3.0

Category, Item No., Class	Summary No./ComplD/System	Scope / Method / Procedure	Dwg/ISO No. Comp. Desc. Code Case		Period 1		Period 2		Period 3	
					2VR13	2VR14	2VR14A	2VR15	2VR16	2VR17
C-F-2	V2 21302-110-9		ISI-21302-110	ISI	-	-	-	-	-	-
C5.51	21302-110-9		6" ELBOW TO PIPE	AUG	-	-	-	-	-	-
2	1302			OWN	-	-	-	-	-	-
				PRE	-	-	-	-	-	-
C-F-2	V2 21305-058-1		ISI-21305-058	ISI	-	-	-	-	-	-
C5.51	21305-058-1		FORGING TO 16" PIPE (TS 5.5.16)	AUG	-	-	-	-	-	-
2	1305			OWN	-	-	-	-	-	-
				PRE	-	-	-	-	-	-
C-F-2	V2 21305-058-10		ISI-21305-058	ISI	-	-	-	-	-	-
C5.51	21305-058-10		16" PIPE TO PIPE	AUG	-	-	-	-	-	-
2	1305			OWN	-	-	-	-	-	-
				PRE	-	-	-	-	-	-
C-F-2	V2 21305-058-12		ISI-21305-058	ISI	-	-	-	-	-	-
C5.51	21305-058-12		16" PIPE TO ELBOW	AUG	-	-	-	-	-	-
2	1305			OWN	-	-	-	-	-	-
				PRE	-	-	-	-	-	-
C-F-2	V2 21305-058-13		ISI-21305-058	ISI	-	-	-	-	-	-
C5.51	21305-058-13		16" ELBOW TO PIPE	AUG	-	-	-	-	-	-
2	1305			OWN	-	-	-	-	-	-
				PRE	-	-	-	-	-	-
C-F-2	V2 21305-058-15		ISI-21305-058	ISI	-	-	-	-	-	-
C5.51	21305-058-15		16" PIPE TO ELBOW	AUG	-	-	-	-	-	-
2	1305			OWN	-	-	-	-	-	-
				PRE	-	-	-	-	-	-
C-F-2	V2 21305-058-16		ISI-21305-058	ISI	-	-	-	-	-	-
C5.51	21305-058-16		16" ELBOW TO PIPE	AUG	-	-	-	-	-	-
2	1305			OWN	-	-	-	-	-	-
				PRE	-	-	-	-	-	-
C-F-2	V2 21305-058-17		ISI-21305-058	ISI	-	-	-	-	-	-
C5.51	21305-058-17		16" PIPE TO ELBOW	AUG	-	-	-	-	-	-
2	1305			OWN	-	-	-	-	-	-
				PRE	-	-	-	-	-	-
C-F-2	V2 21305-058-18		ISI-21305-058	ISI	-	-	-	-	-	-
C5.51	21305-058-18		16" ELBOW TO PIPE	AUG	-	-	-	-	-	-
2	1305			OWN	-	-	-	-	-	-
				PRE	-	-	-	-	-	-
C-F-2	V2 21305-058-19		ISI-21305-058	ISI	-	-	-	-	-	-
C5.51	21305-058-19		16" PIPE TO ELBOW	AUG	-	-	-	-	-	-
2	1305			OWN	-	-	-	-	-	-
				PRE	-	-	-	-	-	-

**Southern Nuclear Operating Company
3rd Interval
VOGTLE-2 ISI PLAN, VERSION 3.0**

Category, Item No., Class	Summary No./CompID/System	Scope / Method / Procedure	Dwg/ISO No. Comp. Desc. Code Case		Period 1		Period 2			Period 3	
					2VR13	2VR14	2VR14A	2VR15	2VR16	2VR17	2VR18
C-F-2 C5.51 2	V2 21305-058-20 21305-058-20 1305		ISI-21305-058 16" ELBOW TO PIPE	ISI AUG OWN PRE	-	-	-	-	-	-	-
C-F-2 C5.51 2	V2 21305-058-21 21305-058-21 1305		ISI-21305-058 16" PIPE TO ELBOW	ISI AUG OWN PRE	-	-	-	-	-	-	-
C-F-2 C5.51 2	V2 21305-058-22 21305-058-22 1305		ISI-21305-058 16" ELBOW TO PIPE	ISI AUG OWN PRE	-	-	-	-	-	-	-
C-F-2 C5.51 2	V2 21305-058-23 21305-058-23 1305		ISI-21305-058 16" PIPE TO NOZZLE	ISI AUG OWN PRE	-	-	-	-	-	-	-
C-F-2 C5.51 2	V2 21305-058-4 21305-058-4 1305	ISI/UT/	ISI-21305-058 16" PIPE TO VALVE (TS 5.5.16)	ISI AUG OWN PRE	-	-	-	-	s	-	-
C-F-2 C5.51 2	V2 21305-058-5 21305-058-5 1305		ISI-21305-058 16" VALVE TO PIPE (TS 5.5.16)	ISI AUG OWN PRE	-	-	-	-	-	-	-
C-F-2 C5.51 2	V2 21305-058-6 21305-058-6 1305		ISI-21305-058 16" PIPE TO VALVE (TS 5.5.16)	ISI AUG OWN PRE	-	-	-	-	-	-	-
C-F-2 C5.51 2	V2 21305-058-7 21305-058-7 1305		ISI-21305-058 16" VALVE TO PIPE (TS 5.5.16)	ISI AUG OWN PRE	-	-	-	-	-	-	-
C-F-2 C5.51 2	V2 21305-058-8 21305-058-8 1305		ISI-21305-058 16" PIPE TO PENETRATION (TS 5.5.16)	ISI AUG OWN PRE	-	-	-	-	-	-	-
C-F-2 C5.51 2	V2 21305-058-9 21305-058-9 1305		ISI-21305-058 PENETRATION TO 16" PIPE	ISI AUG OWN PRE	-	-	-	-	-	-	-

**Southern Nuclear Operating Company
3rd Interval
VOGTLE-2 ISI PLAN, VERSION 3.0**

Category, Item No., Class	Summary No./ComplD/System	Scope / Method / Procedure	Dwg/ISO No. Comp. Desc. Code Case		Period 1		Period 2			Period 3	
					2VR13	2VR14	2VR14A	2VR15	2VR16	2VR17	2VR18
C-F-2 C5.51 2	V2 21305-060-1 21305-060-1 1305		ISI-21305-060 FORGING TO 16" PIPE (TS 5.5.16)	ISI AUG OWN PRE	-	-	-	-	-	-	-
C-F-2 C5.51 2	V2 21305-060-10 21305-060-10 1305		ISI-21305-060 16" PIPE TO PIPE	ISI AUG OWN PRE	-	-	-	-	-	-	-
C-F-2 C5.51 2	V2 21305-060-12 21305-060-12 1305		ISI-21305-060 16" PIPE TO ELBOW	ISI AUG OWN PRE	-	-	-	-	-	-	-
C-F-2 C5.51 2	V2 21305-060-13 21305-060-13 1305		ISI-21305-060 16" ELBOW TO PIPE	ISI AUG OWN PRE	-	-	-	-	-	-	-
C-F-2 C5.51 2	V2 21305-060-15 21305-060-15 1305		ISI-21305-060 16" PIPE TO ELBOW	ISI AUG OWN PRE	-	-	-	-	-	-	-
C-F-2 C5.51 2	V2 21305-060-16 21305-060-16 1305		ISI-21305-060 16" ELBOW TO PIPE	ISI AUG OWN PRE	-	-	-	-	-	-	-
C-F-2 C5.51 2	V2 21305-060-17 21305-060-17 1305		ISI-21305-060 16" PIPE TO ELBOW	ISI AUG OWN PRE	-	-	-	-	-	-	-
C-F-2 C5.51 2	V2 21305-060-18 21305-060-18 1305		ISI-21305-060 16" ELBOW TO PIPE	ISI AUG OWN PRE	-	-	-	-	-	-	-
C-F-2 C5.51 2	V2 21305-060-19 21305-060-19 1305		ISI-21305-060 16" PIPE TO ELBOW	ISI AUG OWN PRE	-	-	-	-	-	-	-
C-F-2 C5.51 2	V2 21305-060-20 21305-060-20 1305		ISI-21305-060 16" ELBOW TO PIPE	ISI AUG OWN PRE	-	-	-	-	-	-	-

**Southern Nuclear Operating Company
3rd Interval
VOGTLE-2 ISI PLAN, VERSION 3.0**

Category, Item No., Class	Summary No./ComplID/System	Scope / Method / Procedure	Dwg/ISO No. Comp. Desc. Code Case		Period 1		Period 2		Period 3	
					2VR13	2VR14	2VR14A	2VR15	2VR16	2VR17
C-F-2 C5.51 2	V2 21305-060-21 21305-060-21 1305		ISI-21305-060 16" PIPE TO ELBOW	ISI AUG OWN PRE	- - - -	- - - -	- - - -	- - - -	- - - -	- - - -
C-F-2 C5.51 2	V2 21305-060-22 21305-060-22 1305		ISI-21305-060 16" ELBOW TO PIPE	ISI AUG OWN PRE	- - - -	- - - -	- - - -	- - - -	- - - -	- - - -
C-F-2 C5.51 2	V2 21305-060-23 21305-060-23 1305		ISI-21305-060 16" PIPE TO NOZZLE	ISI AUG OWN PRE	- - - -	- - - -	- - - -	- - - -	- - - -	- - - -
C-F-2 C5.51 2	V2 21305-060-4 21305-060-4 1305	ISI/UT/NMP-ES-024-502	ISI-21305-060 16" PIPE TO VALVE (TS 5.5.16)	ISI AUG OWN PRE	- - - -	s - - -	- - - -	- - - -	- - - -	- - - -
C-F-2 C5.51 2	V2 21305-060-5 21305-060-5 1305		ISI-21305-060 16" VALVE TO PIPE (TS 5.5.16)	ISI AUG OWN PRE	- - - -	- - - -	- - - -	- - - -	- - - -	- - - -
C-F-2 C5.51 2	V2 21305-060-6 21305-060-6 1305		ISI-21305-060 16" PIPE TO VALVE (TS 5.5.16)	ISI AUG OWN PRE	- - - -	- - - -	- - - -	- - - -	- - - -	- - - -
C-F-2 C5.51 2	V2 21305-060-7 21305-060-7 1305	ISI/UT/NMP-ES-024-502	ISI-21305-060 16" VALVE TO PIPE (TS 5.5.16)	ISI AUG OWN PRE	- - - -	s - - -	- - - -	- - - -	- - - -	- - - -
C-F-2 C5.51 2	V2 21305-060-8 21305-060-8 1305	ISI/UT/NMP-ES-024-502	ISI-21305-060 16" PIPE TO PENETRATION (TS 5.5.16)	ISI AUG OWN PRE	- - - -	s - - -	- - - -	- - - -	- - - -	- - - -
C-F-2 C5.51 2	V2 21305-060-9 21305-060-9 1305		ISI-21305-060 16" PENETRATION TO PIPE	ISI AUG OWN PRE	- - - -	- - - -	- - - -	- - - -	- - - -	- - - -
C-F-2 C5.51 2	V2 21305-062-1 21305-062-1 1305	ISI/UT/	ISI-21305-062 FORGING TO 16" PIPE (TS 5.5.16)	ISI AUG OWN PRE	- - - -	- - - -	- - - -	- - - -	- - - -	s - - -

Southern Nuclear Operating Company
3rd Interval
VOGTLE-2 ISI PLAN, VERSION 3.0

Category, Item No., Class	Summary No./ComplD/System	Scope / Method / Procedure	Dwg/ISO No. Comp. Desc. Code Case		Period 1		Period 2			Period 3	
					2VR13	2VR14	2VR14A	2VR15	2VR16	2VR17	2VR18
C-F-2	V2 21305-062-10		ISI-21305-062	ISI	-	-	-	-	-	-	-
C5.51	21305-062-10		16" VALVE TO PIPE (TS 5.5.16)	AUG	-	-	-	-	-	-	-
2	1305			OWN	-	-	-	-	-	-	-
				PRE	-	-	-	-	-	-	-
C-F-2	V2 21305-062-11		ISI-21305-062	ISI	-	-	-	-	-	-	-
C5.51	21305-062-11		16" PIPE TO PENETRATION (TS 5.5.16)	AUG	-	-	-	-	-	-	-
2	1305			OWN	-	-	-	-	-	-	-
				PRE	-	-	-	-	-	-	-
C-F-2	V2 21305-062-12		ISI-21305-062	ISI	-	-	-	-	-	-	-
C5.51	21305-062-12		PENETRATION TO 16" PIPE	AUG	-	-	-	-	-	-	-
2	1305			OWN	-	-	-	-	-	-	-
				PRE	-	-	-	-	-	-	-
C-F-2	V2 21305-062-13		ISI-21305-062	ISI	-	-	-	-	-	-	-
C5.51	21305-062-13		16" PIPE TO PIPE	AUG	-	-	-	-	-	-	-
2	1305			OWN	-	-	-	-	-	-	-
				PRE	-	-	-	-	-	-	-
C-F-2	V2 21305-062-15		ISI-21305-062	ISI	-	-	-	-	-	-	-
C5.51	21305-062-15		16" PIPE TO ELBOW	AUG	-	-	-	-	-	-	-
2	1305			OWN	-	-	-	-	-	-	-
				PRE	-	-	-	-	-	-	-
C-F-2	V2 21305-062-16		ISI-21305-062	ISI	-	-	-	-	-	-	-
C5.51	21305-062-16		16" ELBOW TO PIPE	AUG	-	-	-	-	-	-	-
2	1305			OWN	-	-	-	-	-	-	-
				PRE	-	-	-	-	-	-	-
C-F-2	V2 21305-062-18		ISI-21305-062	ISI	-	-	-	-	-	-	-
C5.51	21305-062-18		16" PIPE TO ELBOW	AUG	-	-	-	-	-	-	-
2	1305			OWN	-	-	-	-	-	-	-
				PRE	-	-	-	-	-	-	-
C-F-2	V2 21305-062-19		ISI-21305-062	ISI	-	-	-	-	-	-	-
C5.51	21305-062-19		16" ELBOW TO PIPE	AUG	-	-	-	-	-	-	-
2	1305			OWN	-	-	-	-	-	-	-
				PRE	-	-	-	-	-	-	-
C-F-2	V2 21305-062-2		ISI-21305-062	ISI	-	-	-	-	-	-	-
C5.51	21305-062-2		16" PIPE TO PIPE (TS 5.5.16)	AUG	-	-	-	-	-	-	-
2	1305			OWN	-	-	-	-	-	-	-
				PRE	-	-	-	-	-	-	-
C-F-2	V2 21305-062-20		ISI-21305-062	ISI	-	-	-	-	-	-	-
C5.51	21305-062-20		16" PIPE TO ELBOW	AUG	-	-	-	-	-	-	-
2	1305			OWN	-	-	-	-	-	-	-
				PRE	-	-	-	-	-	-	-

Southern Nuclear Operating Company
3rd Interval
VOGTLE-2 ISI PLAN, VERSION 3.0

Category, Item No., Class	Summary No./ComplID/System	Scope / Method / Procedure	Dwg/ISO No. Comp. Desc. Code Case		Period 1		Period 2		Period 3	
					2VR13	2VR14	2VR14A	2VR15	2VR16	2VR17
C-F-2	V2 21305-062-21		ISI-21305-062	ISI	-	-	-	-	-	-
C5.51	21305-062-21		16" ELBOW TO PIPE	AUG	-	-	-	-	-	-
2	1305			OWN	-	-	-	-	-	-
				PRE	-	-	-	-	-	-
C-F-2	V2 21305-062-22		ISI-21305-062	ISI	-	-	-	-	-	-
C5.51	21305-062-22		16" PIPE TO ELBOW	AUG	-	-	-	-	-	-
2	1305			OWN	-	-	-	-	-	-
				PRE	-	-	-	-	-	-
C-F-2	V2 21305-062-23		ISI-21305-062	ISI	-	-	-	-	-	-
C5.51	21305-062-23		16" ELBOW TO PIPE	AUG	-	-	-	-	-	-
2	1305			OWN	-	-	-	-	-	-
				PRE	-	-	-	-	-	-
C-F-2	V2 21305-062-24		ISI-21305-062	ISI	-	-	-	-	-	-
C5.51	21305-062-24		16" PIPE TO ELBOW	AUG	-	-	-	-	-	-
2	1305			OWN	-	-	-	-	-	-
				PRE	-	-	-	-	-	-
C-F-2	V2 21305-062-25		ISI-21305-062	ISI	-	-	-	-	-	-
C5.51	21305-062-25		16" ELBOW TO PIPE	AUG	-	-	-	-	-	-
2	1305			OWN	-	-	-	-	-	-
				PRE	-	-	-	-	-	-
C-F-2	V2 21305-062-26		ISI-21305-062	ISI	-	-	-	-	-	-
C5.51	21305-062-26		16" PIPE TO NOZZLE	AUG	-	-	-	-	-	-
2	1305			OWN	-	-	-	-	-	-
				PRE	-	-	-	-	-	-
C-F-2	V2 21305-062-3		ISI-21305-062	ISI	-	-	-	-	-	-
C5.51	21305-062-3		16" PIPE TO PIPE (TS 5.5.16)	AUG	-	-	-	-	-	-
2	1305			OWN	-	-	-	-	-	-
				PRE	-	-	-	-	-	-
C-F-2	V2 21305-062-6		ISI-21305-062	ISI	-	-	-	-	-	-
C5.51	21305-062-6		16" PIPE TO VALVE (TS 5.5.16)	AUG	-	-	-	-	-	-
2	1305			OWN	-	-	-	-	-	-
				PRE	-	-	-	-	-	-
C-F-2	V2 21305-062-7		ISI-21305-062	ISI	-	-	-	-	-	-
C5.51	21305-062-7		16" VALVE TO PIPE (TS 5.5.16)	AUG	-	-	-	-	-	-
2	1305			OWN	-	-	-	-	-	-
				PRE	-	-	-	-	-	-
C-F-2	V2 21305-062-9		ISI-21305-062	ISI	-	-	-	-	-	-
C5.51	21305-062-9		16" PIPE TO VALVE (TS 5.5.16)	AUG	-	-	-	-	-	-
2	1305			OWN	-	-	-	-	-	-
				PRE	-	-	-	-	-	-

Southern Nuclear Operating Company
3rd Interval
VOGTLE-2 ISI PLAN, VERSION 3.0

Category, Item No., Class	Summary No./ComplID/System	Scope / Method / Procedure	Dwg/ISO No. Comp. Desc. Code Case		Period 1		Period 2		Period 3	
					2VR13	2VR14	2VR14A	2VR15	2VR16	2VR17
C-F-2	V2 21305-064-1	ISI/UT/	ISI-21305-064	ISI	-	-	-	-	-	-
C5.51	21305-064-1		FORGING TO 16" PIPE (TS 5.5.16)	AUG	-	-	-	-	-	-
2	1305			OWN	-	-	-	-	-	-
				PRE	-	-	-	-	-	-
C-F-2	V2 21305-064-1 A		ISI-21305-064	ISI	-	-	-	-	-	-
C5.51	21305-064-1 A		16" PIPE TO PIPE (TS 5.5.16)	AUG	-	-	-	-	-	-
2	1305			OWN	-	-	-	-	-	-
				PRE	-	-	-	-	-	-
C-F-2	V2 21305-064-10		ISI-21305-064	ISI	-	-	-	-	-	-
C5.51	21305-064-10		PENETRATION TO 16" PIPE	AUG	-	-	-	-	-	-
2	1305			OWN	-	-	-	-	-	-
				PRE	-	-	-	-	-	-
C-F-2	V2 21305-064-11		ISI-21305-064	ISI	-	-	-	-	-	-
C5.51	21305-064-11		16" PIPE TO PIPE	AUG	-	-	-	-	-	-
2	1305			OWN	-	-	-	-	-	-
				PRE	-	-	-	-	-	-
C-F-2	V2 21305-064-13		ISI-21305-064	ISI	-	-	-	-	-	-
C5.51	21305-064-13		16" PIPE TO ELBOW	AUG	-	-	-	-	-	-
2	1305			OWN	-	-	-	-	-	-
				PRE	-	-	-	-	-	-
C-F-2	V2 21305-064-14		ISI-21305-064	ISI	-	-	-	-	-	-
C5.51	21305-064-14		16" ELBOW TO PIPE	AUG	-	-	-	-	-	-
2	1305			OWN	-	-	-	-	-	-
				PRE	-	-	-	-	-	-
C-F-2	V2 21305-064-16		ISI-21305-064	ISI	-	-	-	-	-	-
C5.51	21305-064-16		16" PIPE TO ELBOW	AUG	-	-	-	-	-	-
2	1305			OWN	-	-	-	-	-	-
				PRE	-	-	-	-	-	-
C-F-2	V2 21305-064-17		ISI-21305-064	ISI	-	-	-	-	-	-
C5.51	21305-064-17		16" ELBOW TO PIPE	AUG	-	-	-	-	-	-
2	1305			OWN	-	-	-	-	-	-
				PRE	-	-	-	-	-	-
C-F-2	V2 21305-064-18		ISI-21305-064	ISI	-	-	-	-	-	-
C5.51	21305-064-18		16" PIPE TO ELBOW	AUG	-	-	-	-	-	-
2	1305			OWN	-	-	-	-	-	-
				PRE	-	-	-	-	-	-
C-F-2	V2 21305-064-19		ISI-21305-064	ISI	-	-	-	-	-	-
C5.51	21305-064-19		16" ELBOW TO PIPE	AUG	-	-	-	-	-	-
2	1305			OWN	-	-	-	-	-	-
				PRE	-	-	-	-	-	-

Southern Nuclear Operating Company
3rd Interval
VOGTLE-2 ISI PLAN, VERSION 3.0

Category, Item No., Class	Summary No./CompID/System	Scope / Method / Procedure	Dwg/ISO No. Comp. Desc. Code Case		Period 1		Period 2			Period 3	
					2VR13	2VR14	2VR14A	2VR15	2VR16	2VR17	2VR18
C-F-2	V2 21305-064-20		ISI-21305-064	ISI	-	-	-	-	-	-	-
C5.51	21305-064-20		16" PIPE TO ELBOW	AUG	-	-	-	-	-	-	-
2	1305			OWN	-	-	-	-	-	-	-
				PRE	-	-	-	-	-	-	-
C-F-2	V2 21305-064-21		ISI-21305-064	ISI	-	-	-	-	-	-	-
C5.51	21305-064-21		16" ELBOW TO PIPE	AUG	-	-	-	-	-	-	-
2	1305			OWN	-	-	-	-	-	-	-
				PRE	-	-	-	-	-	-	-
C-F-2	V2 21305-064-22	ISI/UT/NMP-ES-024-502	ISI-21305-064	ISI	-	s	-	-	-	-	-
C5.51	21305-064-22		16" PIPE TO ELBOW	AUG	-	-	-	-	-	-	-
2	1305			OWN	-	-	-	-	-	-	-
				PRE	-	-	-	-	-	-	-
C-F-2	V2 21305-064-23	ISI/UT/NMP-ES-024-502	ISI-21305-064	ISI	-	s	-	-	-	-	-
C5.51	21305-064-23		16" ELBOW TO PIPE	AUG	-	-	-	-	-	-	-
2	1305			OWN	-	-	-	-	-	-	-
				PRE	-	-	-	-	-	-	-
C-F-2	V2 21305-064-24	ISI/UT/NMP-ES-024-502	ISI-21305-064	ISI	-	s	-	-	-	-	-
C5.51	21305-064-24		16" PIPE TO NOZZLE	AUG	-	-	-	-	-	-	-
2	1305			OWN	-	-	-	-	-	-	-
				PRE	-	-	-	-	-	-	-
C-F-2	V2 21305-064-4		ISI-21305-064	ISI	-	-	-	-	-	-	-
C5.51	21305-064-4		16" PIPE TO VALVE (TS 5.5.16)	AUG	-	-	-	-	-	-	-
2	1305			OWN	-	-	-	-	-	-	-
				PRE	-	-	-	-	-	-	-
C-F-2	V2 21305-064-5		ISI-21305-064	ISI	-	-	-	-	-	-	-
C5.51	21305-064-5		16" VALVE TO PIPE (TS 5.5.16)	AUG	-	-	-	-	-	-	-
2	1305			OWN	-	-	-	-	-	-	-
				PRE	-	-	-	-	-	-	-
C-F-2	V2 21305-064-7		ISI-21305-064	ISI	-	-	-	-	-	-	-
C5.51	21305-064-7		16" PIPE TO VALVE (TS 5.5.16)	AUG	-	-	-	-	-	-	-
2	1305			OWN	-	-	-	-	-	-	-
				PRE	-	-	-	-	-	-	-
C-F-2	V2 21305-064-8		ISI-21305-064	ISI	-	-	-	-	-	-	-
C5.51	21305-064-8		16" VALVE TO PIPE (TS 5.5.16)	AUG	-	-	-	-	-	-	-
2	1305			OWN	-	-	-	-	-	-	-
				PRE	-	-	-	-	-	-	-
C-F-2	V2 21305-064-9		ISI-21305-064	ISI	-	-	-	-	-	-	-
C5.51	21305-064-9		16" PIPE TO PENETRATION (TS 5.5.16)	AUG	-	-	-	-	-	-	-
2	1305			OWN	-	-	-	-	-	-	-
				PRE	-	-	-	-	-	-	-

**Southern Nuclear Operating Company
3rd Interval
VOGTLE-2 ISI PLAN, VERSION 3.0**

Category, Item No., Class	Summary No./ComplD/System	Scope / Method / Procedure	Dwg/ISO No. Comp. Desc. Code Case		Period 1		Period 2			Period 3	
					2VR13	2VR14	2VR14A	2VR15	2VR16	2VR17	2VR18
C-F-2	V2 21305-154-1R		ISI-21305-154	ISI	-	-	-	-	-	-	-
C5.51	21305-154-1R		BRANCH CONNECTION TO 6" PIPE	AUG	-	-	-	-	-	-	-
2	1305			OWN	-	-	-	-	-	-	-
				PRE	-	-	-	-	-	-	-
C-F-2	V2 21305-154-2R		ISI-21305-154	ISI	-	-	-	-	-	-	-
C5.51	21305-154-2R		6" PIPE TO ELBOW	AUG	-	-	-	-	-	-	-
2	1305			OWN	-	-	-	-	-	-	-
				PRE	-	-	-	-	-	-	-
C-F-2	V2 21305-154-3		ISI-21305-154	ISI	-	-	-	-	-	-	-
C5.51	21305-154-3		6" ELBOW TO PIPE	AUG	-	-	-	-	-	-	-
2	1305			OWN	-	-	-	-	-	-	-
				PRE	-	-	-	-	-	-	-
C-F-2	V2 21305-154-4		ISI-21305-154	ISI	-	-	-	-	-	-	-
C5.51	21305-154-4		6" PIPE TO ELBOW	AUG	-	-	-	-	-	-	-
2	1305			OWN	-	-	-	-	-	-	-
				PRE	-	-	-	-	-	-	-
C-F-2	V2 21305-154-5		ISI-21305-154	ISI	-	-	-	-	-	-	-
C5.51	21305-154-5		6" ELBOW TO PIPE	AUG	-	-	-	-	-	-	-
2	1305			OWN	-	-	-	-	-	-	-
				PRE	-	-	-	-	-	-	-
C-F-2	V2 21305-154-6		ISI-21305-154	ISI	-	-	-	-	-	-	-
C5.51	21305-154-6		6" PIPE TO VALVE	AUG	-	-	-	-	-	-	-
2	1305			OWN	-	-	-	-	-	-	-
				PRE	-	-	-	-	-	-	-
C-F-2	V2 21305-155-1		ISI-21305-155	ISI	-	-	-	-	-	-	-
C5.51	21305-155-1		BRANCH CONNECTION TO 6" PIPE	AUG	-	-	-	-	-	-	-
2	1305			OWN	-	-	-	-	-	-	-
				PRE	-	-	-	-	-	-	-
C-F-2	V2 21305-155-2		ISI-21305-155	ISI	-	-	-	-	-	-	-
C5.51	21305-155-2		6" PIPE TO ELBOW	AUG	-	-	-	-	-	-	-
2	1305			OWN	-	-	-	-	-	-	-
				PRE	-	-	-	-	-	-	-
C-F-2	V2 21305-155-3		ISI-21305-155	ISI	-	-	-	-	-	-	-
C5.51	21305-155-3		6" ELBOW TO PIPE	AUG	-	-	-	-	-	-	-
2	1305			OWN	-	-	-	-	-	-	-
				PRE	-	-	-	-	-	-	-
C-F-2	V2 21305-155-4		ISI-21305-155	ISI	-	-	-	-	-	-	-
C5.51	21305-155-4		6" PIPE TO ELBOW	AUG	-	-	-	-	-	-	-
2	1305			OWN	-	-	-	-	-	-	-
				PRE	-	-	-	-	-	-	-

Southern Nuclear Operating Company
3rd Interval
VOGTLE-2 ISI PLAN, VERSION 3.0

Category, Item No., Class	Summary No./ComplID/System	Scope / Method / Procedure	Dwg/ISO No. Comp. Desc. Code Case		Period 1		Period 2		Period 3	
					2VR13	2VR14	2VR14A	2VR15	2VR16	2VR17
C-F-2 C5.51 2	V2 21305-155-5 21305-155-5 1305		ISI-21305-155 6" ELBOW TO PIPE	ISI AUG OWN PRE	-	-	-	-	-	-
C-F-2 C5.51 2	V2 21305-155-6 21305-155-6 1305		ISI-21305-155 6" PIPE TO ELBOW	ISI AUG OWN PRE	-	-	-	-	-	-
C-F-2 C5.51 2	V2 21305-155-7 21305-155-7 1305		ISI-21305-155 6" ELBOW TO PIPE	ISI AUG OWN PRE	-	-	-	-	-	-
C-F-2 C5.51 2	V2 21305-155-8 21305-155-8 1305		ISI-21305-155 6" PIPE TO VALVE	ISI AUG OWN PRE	-	-	-	-	-	-
C-F-2 C5.51 2	V2 21305-156-1 21305-156-1 1305		ISI-21305-156 BRANCH CONNECTION TO 6" PIPE	ISI AUG OWN PRE	-	-	-	-	-	-
C-F-2 C5.51 2	V2 21305-156-2 21305-156-2 1305		ISI-21305-156 6" PIPE TO ELBOW	ISI AUG OWN PRE	-	-	-	-	-	-
C-F-2 C5.51 2	V2 21305-156-3 21305-156-3 1305		ISI-21305-156 6" ELBOW TO PIPE	ISI AUG OWN PRE	-	-	-	-	-	-
C-F-2 C5.51 2	V2 21305-156-4 21305-156-4 1305		ISI-21305-156 6" PIPE TO ELBOW	ISI AUG OWN PRE	-	-	-	-	-	-
C-F-2 C5.51 2	V2 21305-156-5 21305-156-5 1305		ISI-21305-156 6" ELBOW TO PIPE	ISI AUG OWN PRE	-	-	-	-	-	-
C-F-2 C5.51 2	V2 21305-156-6 21305-156-6 1305		ISI-21305-156 6" PIPE TO VALVE	ISI AUG OWN PRE	-	-	-	-	-	-

**Southern Nuclear Operating Company
3rd Interval
VOGTLE-2 ISI PLAN, VERSION 3.0**

Category, Item No., Class	Summary No./ComplD/System	Scope / Method / Procedure	Dwg/ISO No. Comp. Desc. Code Case		Period 1		Period 2			Period 3	
					2VR13	2VR14	2VR14A	2VR15	2VR16	2VR17	2VR18
C-F-2 C5.51 2	V2 21305-157-1A 21305-157-1A 1305	ISI/UT/NMP-ES-024-502 ISI/UT/NMP-ES-024-502 ISI/UT/NMP-ES-024-502	ISI-21305-157 BRANCH CONNECTION TO 6" PIPE	ISI AUG OWN PRE	B	-	-	-	-	-	-
C-F-2 C5.51 2	V2 21305-157-2A 21305-157-2A 1305	ISI/UT/NMP-ES-024-502 ISI/UT/NMP-ES-024-502	ISI-21305-157 6" PIPE TO ELBOW	ISI AUG OWN PRE	B	-	-	-	-	-	-
C-F-2 C5.51 2	V2 21305-157-3A 21305-157-3A 1305	ISI/UT/NMP-ES-024-502	ISI-21305-157 6" ELBOW TO PIPE	ISI AUG OWN PRE	B	-	-	-	-	-	-
C-F-2 C5.51 2	V2 21305-157-4A 21305-157-4A 1305	ISI/UT/NMP-ES-024-502	ISI-21305-157 6" PIPE TO ELBOW	ISI AUG OWN PRE	B	-	-	-	-	-	-
C-F-2 C5.51 2	V2 21305-157-5 21305-157-5 1305		ISI-21305-157 6" ELBOW TO PIPE	ISI AUG OWN PRE		-	-	-	-	-	-
C-F-2 C5.51 2	V2 21305-157-6 21305-157-6 1305		ISI-21305-157 6" PIPE TO ELBOW	ISI AUG OWN PRE		-	-	-	-	-	-
C-F-2 C5.51 2	V2 21305-157-7 21305-157-7 1305		ISI-21305-157 6" ELBOW TO PIPE	ISI AUG OWN PRE		-	-	-	-	-	-
C-F-2 C5.51 2	V2 21305-157-8 21305-157-8 1305		ISI-21305-157 6" PIPE TO VALVE	ISI AUG OWN PRE		-	-	-	-	-	-
C-F-2 C5.60 2	V2 21302-029-1 21302-029-1 1302		ISI-21302-029 4" VALVE TO PIPE	ISI AUG OWN PRE		-	-	-	-	-	-
C-F-2 C5.60 2	V2 21302-029-10 21302-029-10 1302		ISI-21302-029 4" ELBOW TO PIPE	ISI AUG OWN PRE		-	-	-	-	-	-

Southern Nuclear Operating Company
3rd Interval
VOGTLE-2 ISI PLAN, VERSION 3.0

Category, Item No., Class	Summary No./ComplD/System	Scope / Method / Procedure	Dwg/ISO No. Comp. Desc. Code Case		Period 1		Period 2			Period 3	
					2VR13	2VR14	2VR14A	2VR15	2VR16	2VR17	2VR18
C-F-2 C5.60 2	V2 21302-029-11 21302-029-11 1302		ISI-21302-029 4" PIPE TO ELBOW	ISI AUG OWN PRE	-	-	-	-	-	-	-
C-F-2 C5.60 2	V2 21302-029-12 21302-029-12 1302		ISI-21302-029 4" ELBOW TO PIPE	ISI AUG OWN PRE	-	-	-	-	-	-	-
C-F-2 C5.60 2	V2 21302-029-13 21302-029-13 1302		ISI-21302-029 4" PIPE TO ELBOW	ISI AUG OWN PRE	-	-	-	-	-	-	-
C-F-2 C5.60 2	V2 21302-029-14 21302-029-14 1302		ISI-21302-029 4" ELBOW TO PIPE	ISI AUG OWN PRE	-	-	-	-	-	-	-
C-F-2 C5.60 2	V2 21302-029-15 21302-029-15 1302		ISI-21302-029 4" PIPE TO ELBOW	ISI AUG OWN PRE	-	-	-	-	-	-	-
C-F-2 C5.60 2	V2 21302-029-16 21302-029-16 1302		ISI-21302-029 4" ELBOW TO PIPE	ISI AUG OWN PRE	-	-	-	-	-	-	-
C-F-2 C5.60 2	V2 21302-029-17 21302-029-17 1302		ISI-21302-029 4" PIPE TO ELBOW	ISI AUG OWN PRE	-	-	-	-	-	-	-
C-F-2 C5.60 2	V2 21302-029-18 21302-029-18 1302		ISI-21302-029 4" ELBOW TO PIPE	ISI AUG OWN PRE	-	-	-	-	-	-	-
C-F-2 C5.60 2	V2 21302-029-2 21302-029-2 1302		ISI-21302-029 4" PIPE TO FLOW ORIFICE	ISI AUG OWN PRE	-	-	-	-	-	-	-
C-F-2 C5.60 2	V2 21302-029-20 21302-029-20 1302		ISI-21302-029 4" PIPE TO FLOW ELEMENT	ISI AUG OWN PRE	-	-	-	-	-	-	-

**Southern Nuclear Operating Company
3rd Interval
VOGTLE-2 ISI PLAN, VERSION 3.0**

Category, Item No., Class	Summary No./CompID/System	Scope / Method / Procedure	Dwg/ISO No. Comp. Desc. Code Case		Period 1		Period 2			Period 3	
					2VR13	2VR14	2VR14A	2VR15	2VR16	2VR17	2VR18
C-F-2 C5.60 2	V2 21302-029-21 21302-029-21 1302		ISI-21302-029 4" FLOW ELEMENT TO PIPE	ISI AUG OWN PRE	-	-	-	-	-	-	-
C-F-2 C5.60 2	V2 21302-029-22 21302-029-22 1302		ISI-21302-029 4" PIPE TO TEE	ISI AUG OWN PRE	-	-	-	-	-	-	-
C-F-2 C5.60 2	V2 21302-029-23 21302-029-23 1302		ISI-21302-029 4" TEE TO PIPE	ISI AUG OWN PRE	-	-	-	-	-	-	-
C-F-2 C5.60 2	V2 21302-029-24 21302-029-24 1302		ISI-21302-029 4" PIPE TO ELBOW	ISI AUG OWN PRE	-	-	-	-	-	-	-
C-F-2 C5.60 2	V2 21302-029-25 21302-029-25 1302		ISI-21302-029 4" ELBOW TO PIPE	ISI AUG OWN PRE	-	-	-	-	-	-	-
C-F-2 C5.60 2	V2 21302-029-26 21302-029-26 1302		ISI-21302-029 4" PIPE TO ELBOW	ISI AUG OWN PRE	-	-	-	-	-	-	-
C-F-2 C5.60 2	V2 21302-029-27 21302-029-27 1302		ISI-21302-029 4" ELBOW TO PIPE	ISI AUG OWN PRE	-	-	-	-	-	-	-
C-F-2 C5.60 2	V2 21302-029-28 21302-029-28 1302		ISI-21302-029 4" PIPE TO ELBOW	ISI AUG OWN PRE	-	-	-	-	-	-	-
C-F-2 C5.60 2	V2 21302-029-29 21302-029-29 1302		ISI-21302-029 4" ELBOW TO PIPE	ISI AUG OWN PRE	-	-	-	-	-	-	-
C-F-2 C5.60 2	V2 21302-029-3 21302-029-3 1302		ISI-21302-029 4" FLOW ORIFICE TO PIPE	ISI AUG OWN PRE	-	-	-	-	-	-	-

Southern Nuclear Operating Company
3rd Interval
VOGTLE-2 ISI PLAN, VERSION 3.0

Category, Item No., Class	Summary No./CompID/System	Scope / Method / Procedure	Dwg/ISO No. Comp. Desc. Code Case		Period 1		Period 2			Period 3	
					2VR13	2VR14	2VR14A	2VR15	2VR16	2VR17	2VR18
C-F-2 C5.60 2	V2 21302-029-30 21302-029-30 1302		ISI-21302-029 4" PIPE TO ELBOW	ISI AUG OWN PRE	-	-	-	-	-	-	-
C-F-2 C5.60 2	V2 21302-029-31 21302-029-31 1302		ISI-21302-029 4" ELBOW TO PIPE	ISI AUG OWN PRE	-	-	-	-	-	-	-
C-F-2 C5.60 2	V2 21302-029-33 21302-029-33 1302		ISI-21302-029 4" PIPE TO ELBOW	ISI AUG OWN PRE	-	-	-	-	-	-	-
C-F-2 C5.60 2	V2 21302-029-34 21302-029-34 1302		ISI-21302-029 4" ELBOW TO PIPE	ISI AUG OWN PRE	-	-	-	-	-	-	-
C-F-2 C5.60 2	V2 21302-029-35 21302-029-35 1302		ISI-21302-029 4" PIPE TO PIPE	ISI AUG OWN PRE	-	-	-	-	-	-	-
C-F-2 C5.60 2	V2 21302-029-36 21302-029-36 1302		ISI-21302-029 4" PIPE TO ELBOW	ISI AUG OWN PRE	-	-	-	-	-	-	-
C-F-2 C5.60 2	V2 21302-029-37 21302-029-37 1302		ISI-21302-029 4" ELBOW TO PIPE	ISI AUG OWN PRE	-	-	-	-	-	-	-
C-F-2 C5.60 2	V2 21302-029-38 21302-029-38 1302		ISI-21302-029 4" PIPE TO ELBOW	ISI AUG OWN PRE	-	-	-	-	-	-	-
C-F-2 C5.60 2	V2 21302-029-39 21302-029-39 1302		ISI-21302-029 4" ELBOW TO PIPE	ISI AUG OWN PRE	-	-	-	-	-	-	-
C-F-2 C5.60 2	V2 21302-029-4 21302-029-4 1302		ISI-21302-029 4" PIPE TO PIPE	ISI AUG OWN PRE	-	-	-	-	-	-	-

**Southern Nuclear Operating Company
3rd Interval
VOGTLE-2 ISI PLAN, VERSION 3.0**

Category, Item No., Class	Summary No./CompID/System	Scope / Method / Procedure	Dwg/ISO No. Comp. Desc. Code Case		Period 1		Period 2			Period 3	
					2VR13	2VR14	2VR14A	2VR15	2VR16	2VR17	2VR18
C-F-2 C5.60 2	V2 21302-029-40 21302-029-40 1302		ISI-21302-029 4" PIPE TO VALVE	ISI AUG OWN PRE	-	-	-	-	-	-	-
C-F-2 C5.60 2	V2 21302-029-41 21302-029-41 1302		ISI-21302-029 4" VALVE TO PIPE	ISI AUG OWN PRE	-	-	-	-	-	-	-
C-F-2 C5.60 2	V2 21302-029-42 21302-029-42 1302		ISI-21302-029 4" PIPE TO ELBOW	ISI AUG OWN PRE	-	-	-	-	-	-	-
C-F-2 C5.60 2	V2 21302-029-43 21302-029-43 1302		ISI-21302-029 4" ELBOW TO PIPE	ISI AUG OWN PRE	-	-	-	-	-	-	-
C-F-2 C5.60 2	V2 21302-029-44 21302-029-44 1302		ISI-21302-029 4" PIPE TO ELBOW	ISI AUG OWN PRE	-	-	-	-	-	-	-
C-F-2 C5.60 2	V2 21302-029-45 21302-029-45 1302		ISI-21302-029 4" ELBOW TO PIPE	ISI AUG OWN PRE	-	-	-	-	-	-	-
C-F-2 C5.60 2	V2 21302-029-46 21302-029-46 1302		ISI-21302-029 4" PIPE TO TEE	ISI AUG OWN PRE	-	-	-	-	-	-	-
C-F-2 C5.60 2	V2 21302-029-5 21302-029-5 1302		ISI-21302-029 4" PIPE TO VALVE	ISI AUG OWN PRE	-	-	-	-	-	-	-
C-F-2 C5.60 2	V2 21302-029-6 21302-029-6 1302		ISI-21302-029 4" VALVE TO PIPE	ISI AUG OWN PRE	-	-	-	-	-	-	-
C-F-2 C5.60 2	V2 21302-029-7 21302-029-7 1302		ISI-21302-029 4" PIPE TO TEE	ISI AUG OWN PRE	-	-	-	-	-	-	-

Southern Nuclear Operating Company
3rd Interval
VOGTLE-2 ISI PLAN, VERSION 3.0

Category, Item No., Class	Summary No./CompID/System	Scope / Method / Procedure	Dwg/ISO No. Comp. Desc. Code Case		Period 1		Period 2			Period 3	
					2VR13	2VR14	2VR14A	2VR15	2VR16	2VR17	2VR18
C-F-2 C5.60 2	V2 21302-029-8 21302-029-8 1302		ISI-21302-029 4" TEE TO PIPE	ISI AUG OWN PRE	-	-	-	-	-	-	-
C-F-2 C5.60 2	V2 21302-029-9 21302-029-9 1302		ISI-21302-029 4" PIPE TO ELBOW	ISI AUG OWN PRE	-	-	-	-	-	-	-
C-F-2 C5.60 2	V2 21302-030-1 21302-030-1 1302		ISI-21302-030 4" VALVE TO PIPE	ISI AUG OWN PRE	-	-	-	-	-	-	-
C-F-2 C5.60 2	V2 21302-030-10 21302-030-10 1302		ISI-21302-030 4" PIPE TO ELBOW	ISI AUG OWN PRE	-	-	-	-	-	-	-
C-F-2 C5.60 2	V2 21302-030-11 21302-030-11 1302	ISI/UT/	ISI-21302-030 4" ELBOW TO PIPE	ISI AUG OWN PRE	-	-	-	s	-	-	-
C-F-2 C5.60 2	V2 21302-030-12 21302-030-12 1302		ISI-21302-030 4" PIPE TO ELBOW	ISI AUG OWN PRE	-	-	-	-	-	-	-
C-F-2 C5.60 2	V2 21302-030-13 21302-030-13 1302		ISI-21302-030 4" ELBOW TO PIPE	ISI AUG OWN PRE	-	-	-	-	-	-	-
C-F-2 C5.60 2	V2 21302-030-14 21302-030-14 1302		ISI-21302-030 4" PIPE TO ELBOW	ISI AUG OWN PRE	-	-	-	-	-	-	-
C-F-2 C5.60 2	V2 21302-030-15 21302-030-15 1302		ISI-21302-030 4" ELBOW TO PIPE	ISI AUG OWN PRE	-	-	-	-	-	-	-
C-F-2 C5.60 2	V2 21302-030-16 21302-030-16 1302		ISI-21302-030 4" PIPE TO ELBOW	ISI AUG OWN PRE	-	-	-	-	-	-	-

**Southern Nuclear Operating Company
3rd Interval
VOGTLE-2 ISI PLAN, VERSION 3.0**

Category, Item No., Class	Summary No./CompID/System	Scope / Method / Procedure	Dwg/ISO No. Comp. Desc. Code Case		Period 1		Period 2			Period 3	
					2VR13	2VR14	2VR14A	2VR15	2VR16	2VR17	2VR18
C-F-2 C5.60 2	V2 21302-030-17 21302-030-17 1302		ISI-21302-030 4" ELBOW TO PIPE	ISI AUG OWN PRE	-	-	-	-	-	-	-
C-F-2 C5.60 2	V2 21302-030-18 21302-030-18 1302		ISI-21302-030 4" PIPE TO ELBOW	ISI AUG OWN PRE	-	-	-	-	-	-	-
C-F-2 C5.60 2	V2 21302-030-19 21302-030-19 1302		ISI-21302-030 4" ELBOW TO PIPE	ISI AUG OWN PRE	-	-	-	-	-	-	-
C-F-2 C5.60 2	V2 21302-030-2 21302-030-2 1302		ISI-21302-030 4" PIPE TO ELBOW	ISI AUG OWN PRE	-	-	-	-	-	-	-
C-F-2 C5.60 2	V2 21302-030-20 21302-030-20 1302		ISI-21302-030 4" PIPE TO FLOW ELEMENT	ISI AUG OWN PRE	-	-	-	-	-	-	-
C-F-2 C5.60 2	V2 21302-030-21 21302-030-21 1302		ISI-21302-030 4" FLOW ELEMENT TO PIPE	ISI AUG OWN PRE	-	-	-	-	-	-	-
C-F-2 C5.60 2	V2 21302-030-22 21302-030-22 1302		ISI-21302-030 4" PIPE TO TEE	ISI AUG OWN PRE	-	-	-	-	-	-	-
C-F-2 C5.60 2	V2 21302-030-23 21302-030-23 1302		ISI-21302-030 4" TEE TO PIPE	ISI AUG OWN PRE	-	-	-	-	-	-	-
C-F-2 C5.60 2	V2 21302-030-24 21302-030-24 1302		ISI-21302-030 4" PIPE TO ELBOW	ISI AUG OWN PRE	-	-	-	-	-	-	-
C-F-2 C5.60 2	V2 21302-030-25 21302-030-25 1302		ISI-21302-030 4" ELBOW TO PIPE	ISI AUG OWN PRE	-	-	-	-	-	-	-

**Southern Nuclear Operating Company
3rd Interval
VOGTLE-2 ISI PLAN, VERSION 3.0**

Category, Item No., Class	Summary No./CompID/System	Scope / Method / Procedure	Dwg/ISO No. Comp. Desc. Code Case		Period 1		Period 2		Period 3	
					2VR13	2VR14	2VR14A	2VR15	2VR16	2VR17
C-F-2	V2 21302-030-26		ISI-21302-030	ISI	-	-	-	-	-	-
C5.60	21302-030-26		4" PIPE TO ELBOW	AUG	-	-	-	-	-	-
2	1302			OWN	-	-	-	-	-	-
				PRE	-	-	-	-	-	-
C-F-2	V2 21302-030-27		ISI-21302-030	ISI	-	-	-	-	-	-
C5.60	21302-030-27		4" ELBOW TO PIPE	AUG	-	-	-	-	-	-
2	1302			OWN	-	-	-	-	-	-
				PRE	-	-	-	-	-	-
C-F-2	V2 21302-030-28		ISI-21302-030	ISI	-	-	-	-	-	-
C5.60	21302-030-28		4" PIPE TO ELBOW	AUG	-	-	-	-	-	-
2	1302			OWN	-	-	-	-	-	-
				PRE	-	-	-	-	-	-
C-F-2	V2 21302-030-29		ISI-21302-030	ISI	-	-	-	-	-	-
C5.60	21302-030-29		4" ELBOW TO PIPE	AUG	-	-	-	-	-	-
2	1302			OWN	-	-	-	-	-	-
				PRE	-	-	-	-	-	-
C-F-2	V2 21302-030-3		ISI-21302-030	ISI	-	-	-	-	-	-
C5.60	21302-030-3		4" ELBOW TO PIPE	AUG	-	-	-	-	-	-
2	1302			OWN	-	-	-	-	-	-
				PRE	-	-	-	-	-	-
C-F-2	V2 21302-030-30		ISI-21302-030	ISI	-	-	-	-	-	-
C5.60	21302-030-30		4" PIPE TO ELBOW	AUG	-	-	-	-	-	-
2	1302			OWN	-	-	-	-	-	-
				PRE	-	-	-	-	-	-
C-F-2	V2 21302-030-31		ISI-21302-030	ISI	-	-	-	-	-	-
C5.60	21302-030-31		4" ELBOW TO PIPE	AUG	-	-	-	-	-	-
2	1302			OWN	-	-	-	-	-	-
				PRE	-	-	-	-	-	-
C-F-2	V2 21302-030-32		ISI-21302-030	ISI	-	-	-	-	-	-
C5.60	21302-030-32		4" PIPE TO ELBOW	AUG	-	-	-	-	-	-
2	1302			OWN	-	-	-	-	-	-
				PRE	-	-	-	-	-	-
C-F-2	V2 21302-030-33		ISI-21302-030	ISI	-	-	-	-	-	-
C5.60	21302-030-33		4" ELBOW TO PIPE	AUG	-	-	-	-	-	-
2	1302			OWN	-	-	-	-	-	-
				PRE	-	-	-	-	-	-
C-F-2	V2 21302-030-34		ISI-21302-030	ISI	-	-	-	-	-	-
C5.60	21302-030-34		4" PIPE TO PIPE	AUG	-	-	-	-	-	-
2	1302			OWN	-	-	-	-	-	-
				PRE	-	-	-	-	-	-

Southern Nuclear Operating Company
3rd Interval
VOGTLE-2 ISI PLAN, VERSION 3.0

Category, Item No., Class	Summary No./CompID/System	Scope / Method / Procedure	Dwg/ISO No. Comp. Desc. Code Case		Period 1		Period 2		Period 3	
					2VR13	2VR14	2VR14A	2VR15	2VR16	2VR17
C-F-2 C5.60 2	V2 21302-030-35 21302-030-35 1302		ISI-21302-030 4" PIPE TO ELBOW	ISI AUG OWN PRE	- - - -	- - - -	- - - -	- - - -	- - - -	- - - -
C-F-2 C5.60 2	V2 21302-030-36 21302-030-36 1302		ISI-21302-030 4" ELBOW TO PIPE	ISI AUG OWN PRE	- - - -	- - - -	- - - -	- - - -	- - - -	- - - -
C-F-2 C5.60 2	V2 21302-030-37 21302-030-37 1302		ISI-21302-030 4" PIPE TO PIPE	ISI AUG OWN PRE	- - - -	- - - -	- - - -	- - - -	- - - -	- - - -
C-F-2 C5.60 2	V2 21302-030-38 21302-030-38 1302		ISI-21302-030 4" PIPE TO ELBOW	ISI AUG OWN PRE	- - - -	- - - -	- - - -	- - - -	- - - -	- - - -
C-F-2 C5.60 2	V2 21302-030-39 21302-030-39 1302		ISI-21302-030 4" ELBOW TO PIPE	ISI AUG OWN PRE	- - - -	- - - -	- - - -	- - - -	- - - -	- - - -
C-F-2 C5.60 2	V2 21302-030-4 21302-030-4 1302		ISI-21302-030 4" PIPE TO FLOW ORIFICE	ISI AUG OWN PRE	- - - -	- - - -	- - - -	- - - -	- - - -	- - - -
C-F-2 C5.60 2	V2 21302-030-40 21302-030-40 1302		ISI-21302-030 4" PIPE TO VALVE	ISI AUG OWN PRE	- - - -	- - - -	- - - -	- - - -	- - - -	- - - -
C-F-2 C5.60 2	V2 21302-030-41 21302-030-41 1302		ISI-21302-030 4" VALVE TO PIPE	ISI AUG OWN PRE	- - - -	- - - -	- - - -	- - - -	- - - -	- - - -
C-F-2 C5.60 2	V2 21302-030-42 21302-030-42 1302		ISI-21302-030 4" PIPE TO ELBOW	ISI AUG OWN PRE	- - - -	- - - -	- - - -	- - - -	- - - -	- - - -
C-F-2 C5.60 2	V2 21302-030-43 21302-030-43 1302		ISI-21302-030 4" ELBOW TO PIPE	ISI AUG OWN PRE	- - - -	- - - -	- - - -	- - - -	- - - -	- - - -

**Southern Nuclear Operating Company
3rd Interval
VOGTLE-2 ISI PLAN, VERSION 3.0**

Category, Item No., Class	Summary No./ComplID/System	Scope / Method / Procedure	Dwg/ISO No. Comp. Desc. Code Case		Period 1		Period 2		Period 3							
					2VR13	2VR14	2VR14A	2VR15	2VR16	2VR17	2VR18					
C-F-2 C5.60 2	V2 21302-030-44 21302-030-44 1302	ISI/UT/	ISI-21302-030 4" PIPE TO ELBOW	ISI AUG OWN PRE	-	-	-	-	-	-	-	-	s	-	-	-
C-F-2 C5.60 2	V2 21302-030-45 21302-030-45 1302		ISI-21302-030 4" ELBOW TO PIPE	ISI AUG OWN PRE	-	-	-	-	-	-	-	-	-	-	-	-
C-F-2 C5.60 2	V2 21302-030-46 21302-030-46 1302	ISI/UT/	ISI-21302-030 4" PIPE TO TEE	ISI AUG OWN PRE	-	-	-	-	-	-	-	-	s	-	-	-
C-F-2 C5.60 2	V2 21302-030-5 21302-030-5 1302		ISI-21302-030 4" FLOW ORIFICE TO PIPE	ISI AUG OWN PRE	-	-	-	-	-	-	-	-	-	-	-	-
C-F-2 C5.60 2	V2 21302-030-6 21302-030-6 1302		ISI-21302-030 4" PIPE TO VALVE	ISI AUG OWN PRE	-	-	-	-	-	-	-	-	-	-	-	-
C-F-2 C5.60 2	V2 21302-030-7 21302-030-7 1302	ISI/UT/	ISI-21302-030 4" VALVE TO PIPE	ISI AUG OWN PRE	-	-	-	-	s	-	-	-	-	-	-	-
C-F-2 C5.60 2	V2 21302-030-8 21302-030-8 1302		ISI-21302-030 4" PIPE TO TEE	ISI AUG OWN PRE	-	-	-	-	-	-	-	-	-	-	-	-
C-F-2 C5.60 2	V2 21302-030-9 21302-030-9 1302		ISI-21302-030 4" TEE TO PIPE	ISI AUG OWN PRE	-	-	-	-	-	-	-	-	-	-	-	-
C-F-2 C5.60 2	V2 21302-031-1 21302-031-1 1302		ISI-21302-031 4" VALVE TO PIPE	ISI AUG OWN PRE	-	-	-	-	-	-	-	-	-	-	-	-
C-F-2 C5.60 2	V2 21302-031-10 21302-031-10 1302		ISI-21302-031 4" PIPE TO TEE	ISI AUG OWN PRE	-	-	-	-	-	-	-	-	-	-	-	-

**Southern Nuclear Operating Company
3rd Interval
VOGTLE-2 ISI PLAN, VERSION 3.0**

Category, Item No., Class	Summary No./CompID/System	Scope / Method / Procedure	Dwg/ISO No. Comp. Desc. Code Case		Period 1		Period 2			Period 3	
					2VR13	2VR14	2VR14A	2VR15	2VR16	2VR17	2VR18
C-F-2 C5.60 2	V2 21302-031-11 21302-031-11 1302		ISI-21302-031 4" TEE TO PIPE	ISI AUG OWN PRE	-	-	-	-	-	-	-
C-F-2 C5.60 2	V2 21302-031-12 21302-031-12 1302		ISI-21302-031 4" PIPE TO VALVE	ISI AUG OWN PRE	-	-	-	-	-	-	-
C-F-2 C5.60 2	V2 21302-031-13 21302-031-13 1302	ISI/UT/	ISI-21302-031 4" VALVE TO PIPE	ISI AUG OWN PRE	-	-	-	-	-	s	-
C-F-2 C5.60 2	V2 21302-031-14 21302-031-14 1302	ISI/UT/	ISI-21302-031 4" PIPE TO ELBOW	ISI AUG OWN PRE	-	-	-	-	-	s	-
C-F-2 C5.60 2	V2 21302-031-15 21302-031-15 1302		ISI-21302-031 4" ELBOW TO PIPE	ISI AUG OWN PRE	-	-	-	-	-	-	-
C-F-2 C5.60 2	V2 21302-031-16 21302-031-16 1302		ISI-21302-031 4" PIPE TO ELBOW	ISI AUG OWN PRE	-	-	-	-	-	-	-
C-F-2 C5.60 2	V2 21302-031-17 21302-031-17 1302		ISI-21302-031 4" ELBOW TO PIPE	ISI AUG OWN PRE	-	-	-	-	-	-	-
C-F-2 C5.60 2	V2 21302-031-18 21302-031-18 1302		ISI-21302-031 4" PIPE TO PIPE	ISI AUG OWN PRE	-	-	-	-	-	-	-
C-F-2 C5.60 2	V2 21302-031-19 21302-031-19 1302	ISI/UT/	ISI-21302-031 4" PIPE TO ELBOW	ISI AUG OWN PRE	-	-	-	s	-	-	-
C-F-2 C5.60 2	V2 21302-031-2 21302-031-2 1302		ISI-21302-031 4" PIPE TO FLOW ORIFICE	ISI AUG OWN PRE	-	-	-	-	-	-	-

**Southern Nuclear Operating Company
3rd Interval
VOGTLE-2 ISI PLAN, VERSION 3.0**

Category, Item No., Class	Summary No./ComplD/System	Scope / Method / Procedure	Dwg/ISO No. Comp. Desc. Code Case		Period 1		Period 2			Period 3	
					2VR13	2VR14	2VR14A	2VR15	2VR16	2VR17	2VR18
C-F-2 C5.60 2	V2 21302-031-20 21302-031-20 1302	ISI/UT/	ISI-21302-031 4" ELBOW TO PIPE	ISI AUG OWN PRE	-	-	-	s	-	-	-
C-F-2 C5.60 2	V2 21302-031-21 21302-031-21 1302	ISI/UT/	ISI-21302-031 4" PIPE TO TEE	ISI AUG OWN PRE	-	-	-	s	-	-	-
C-F-2 C5.60 2	V2 21302-031-3 21302-031-3 1302		ISI-21302-031 4" FLOW ORIFICE TO PIPE	ISI AUG OWN PRE	-	-	-	-	-	-	-
C-F-2 C5.60 2	V2 21302-031-4 21302-031-4 1302		ISI-21302-031 4" PIPE TO VALVE	ISI AUG OWN PRE	-	-	-	-	-	-	-
C-F-2 C5.60 2	V2 21302-031-5 21302-031-5 1302		ISI-21302-031 4" VALVE TO PIPE	ISI AUG OWN PRE	-	-	-	-	-	-	-
C-F-2 C5.60 2	V2 21302-031-6 21302-031-6 1302		ISI-21302-031 4" PIPE TO TEE	ISI AUG OWN PRE	-	-	-	-	-	-	-
C-F-2 C5.60 2	V2 21302-031-7 21302-031-7 1302		ISI-21302-031 4" TEE TO PIPE	ISI AUG OWN PRE	-	-	-	-	-	-	-
C-F-2 C5.60 2	V2 21302-031-8 21302-031-8 1302		ISI-21302-031 4" PIPE TO FLOW ELEMENT	ISI AUG OWN PRE	-	-	-	-	-	-	-
C-F-2 C5.60 2	V2 21302-031-9 21302-031-9 1302		ISI-21302-031 4" FLOW ELEMENT TO PIPE	ISI AUG OWN PRE	-	-	-	-	-	-	-
C-F-2 C5.60 2	V2 21302-032-1 21302-032-1 1302		ISI-21302-032 4" VALVE TO PIPE	ISI AUG OWN PRE	-	-	-	-	-	-	-

**Southern Nuclear Operating Company
3rd Interval
VOGTLE-2 ISI PLAN, VERSION 3.0**

Category, Item No., Class	Summary No./ComplD/System	Scope / Method / Procedure	Dwg/ISO No. Comp. Desc. Code Case		Period 1		Period 2			Period 3	
					2VR13	2VR14	2VR14A	2VR15	2VR16	2VR17	2VR18
C-F-2 C5.60 2	V2 21302-032-10 21302-032-10 1302		ISI-21302-032 4" PIPE TO TEE	ISI AUG OWN PRE	-	-	-	-	-	-	-
C-F-2 C5.60 2	V2 21302-032-11 21302-032-11 1302		ISI-21302-032 4" TEE TO PIPE	ISI AUG OWN PRE	-	-	-	-	-	-	-
C-F-2 C5.60 2	V2 21302-032-12 21302-032-12 1302		ISI-21302-032 4" PIPE TO VALVE	ISI AUG OWN PRE	-	-	-	-	-	-	-
C-F-2 C5.60 2	V2 21302-032-13 21302-032-13 1302		ISI-21302-032 4" VALVE TO PIPE	ISI AUG OWN PRE	-	-	-	-	-	-	-
C-F-2 C5.60 2	V2 21302-032-14 21302-032-14 1302	ISI/UT/	ISI-21302-032 4" PIPE TO ELBOW	ISI AUG OWN PRE	-	-	-	-	-	s	-
C-F-2 C5.60 2	V2 21302-032-15 21302-032-15 1302	ISI/UT/	ISI-21302-032 4" ELBOW TO PIPE	ISI AUG OWN PRE	-	-	-	-	-	s	-
C-F-2 C5.60 2	V2 21302-032-16 21302-032-16 1302		ISI-21302-032 4" PIPE TO ELBOW	ISI AUG OWN PRE	-	-	-	-	-	-	-
C-F-2 C5.60 2	V2 21302-032-17 21302-032-17 1302		ISI-21302-032 4" ELBOW TO PIPE	ISI AUG OWN PRE	-	-	-	-	-	-	-
C-F-2 C5.60 2	V2 21302-032-18 21302-032-18 1302		ISI-21302-032 4" PIPE TO ELBOW	ISI AUG OWN PRE	-	-	-	-	-	-	-
C-F-2 C5.60 2	V2 21302-032-19 21302-032-19 1302		ISI-21302-032 4" ELBOW TO PIPE	ISI AUG OWN PRE	-	-	-	-	-	-	-

Southern Nuclear Operating Company
3rd Interval
VOGTLE-2 ISI PLAN, VERSION 3.0

Category, Item No., Class	Summary No./CompID/System	Scope / Method / Procedure	Dwg/ISO No. Comp. Desc. Code Case		Period 1		Period 2		Period 3	
					2VR13	2VR14	2VR14A	2VR15	2VR16	2VR17
C-F-2 C5.60 2	V2 21302-032-2 21302-032-2 1302		ISI-21302-032 4" PIPE TO FLOW ORIFICE	ISI AUG OWN PRE	-	-	-	-	-	-
C-F-2 C5.60 2	V2 21302-032-20 21302-032-20 1302		ISI-21302-032 4" PIPE TO TEE	ISI AUG OWN PRE	-	-	-	-	-	-
C-F-2 C5.60 2	V2 21302-032-3 21302-032-3 1302		ISI-21302-032 4" FLOW ORIFICE TO PIPE	ISI AUG OWN PRE	-	-	-	-	-	-
C-F-2 C5.60 2	V2 21302-032-4 21302-032-4 1302		ISI-21302-032 4" PIPE TO VALVE	ISI AUG OWN PRE	-	-	-	-	-	-
C-F-2 C5.60 2	V2 21302-032-5 21302-032-5 1302		ISI-21302-032 4" VALVE TO PIPE	ISI AUG OWN PRE	-	-	-	-	-	-
C-F-2 C5.60 2	V2 21302-032-6 21302-032-6 1302		ISI-21302-032 4" PIPE TO TEE	ISI AUG OWN PRE	-	-	-	-	-	-
C-F-2 C5.60 2	V2 21302-032-7 21302-032-7 1302		ISI-21302-032 4" TEE TO PIPE	ISI AUG OWN PRE	-	-	-	-	-	-
C-F-2 C5.60 2	V2 21302-032-8 21302-032-8 1302		ISI-21302-032 4" PIPE TO FLOW ELEMENT	ISI AUG OWN PRE	-	-	-	-	-	-
C-F-2 C5.60 2	V2 21302-032-9 21302-032-9 1302		ISI-21302-032 4" FLOW ELEMENT TO PIPE	ISI AUG OWN PRE	-	-	-	-	-	-
C-F-2 C5.60 2	V2 21302-033-1 21302-033-1 1302		ISI-21302-033 4" VALVE TO PIPE	ISI AUG OWN PRE	-	-	-	-	-	-

**Southern Nuclear Operating Company
3rd Interval
VOGTLE-2 ISI PLAN, VERSION 3.0**

Category, Item No., Class	Summary No./CompID/System	Scope / Method / Procedure	Dwg/ISO No. Comp. Desc. Code Case		Period 1		Period 2		Period 3	
					2VR13	2VR14	2VR14A	2VR15	2VR16	2VR17
C-F-2 C5.60 2	V2 21302-033-2 21302-033-2 1302		ISI-21302-033 4" PIPE TO PIPE	ISI AUG OWN PRE	- - - -	- - - -	- - - -	- - - -	- - - -	- - - -
C-F-2 C5.60 2	V2 21302-033-3 21302-033-3 1302		ISI-21302-033 4" PIPE TO FLOW ORIFICE	ISI AUG OWN PRE	- - - -	- - - -	- - - -	- - - -	- - - -	- - - -
C-F-2 C5.60 2	V2 21302-033-4 21302-033-4 1302		ISI-21302-033 4" FLOW ORIFICE TO PIPE	ISI AUG OWN PRE	- - - -	- - - -	- - - -	- - - -	- - - -	- - - -
C-F-2 C5.60 2	V2 21302-033-5 21302-033-5 1302		ISI-21302-033 4" PIPE TO VALVE	ISI AUG OWN PRE	- - - -	- - - -	- - - -	- - - -	- - - -	- - - -
C-F-2 C5.60 2	V2 21302-033-6 21302-033-6 1302		ISI-21302-033 4" VALVE TO PIPE	ISI AUG OWN PRE	- - - -	- - - -	- - - -	- - - -	- - - -	- - - -
C-F-2 C5.60 2	V2 21302-033-7 21302-033-7 1302		ISI-21302-033 4" PIPE TO ELBOW	ISI AUG OWN PRE	- - - -	- - - -	- - - -	- - - -	- - - -	- - - -
C-F-2 C5.60 2	V2 21302-033-8 21302-033-8 1302		ISI-21302-033 4" ELBOW TO PIPE	ISI AUG OWN PRE	- - - -	- - - -	- - - -	- - - -	- - - -	- - - -
C-F-2 C5.60 2	V2 21302-033-9 21302-033-9 1302		ISI-21302-033 4" PIPE TO TEE	ISI AUG OWN PRE	- - - -	- - - -	- - - -	- - - -	- - - -	- - - -
C-F-2 C5.60 2	V2 21302-034-1 21302-034-1 1302		ISI-21302-034 4" VALVE TO PIPE	ISI AUG OWN PRE	- - - -	- - - -	- - - -	- - - -	- - - -	- - - -
C-F-2 C5.60 2	V2 21302-034-2 21302-034-2 1302		ISI-21302-034 4" PIPE TO FLOW ORIFICE	ISI AUG OWN PRE	- - - -	- - - -	- - - -	- - - -	- - - -	- - - -

**Southern Nuclear Operating Company
3rd Interval
VOGTLE-2 ISI PLAN, VERSION 3.0**

Category, Item No., Class	Summary No./ComplID/System	Scope / Method / Procedure	Dwg/ISO No. Comp. Desc. Code Case		Period 1		Period 2		Period 3	
					2VR13	2VR14	2VR14A	2VR15	2VR16	2VR17
C-F-2 C5.60 2	V2 21302-034-3 21302-034-3 1302		ISI-21302-034 4" FLOW ORIFICE TO PIPE	ISI AUG OWN PRE	-	-	-	-	-	-
C-F-2 C5.60 2	V2 21302-034-4 21302-034-4 1302		ISI-21302-034 4" PIPE TO VALVE	ISI AUG OWN PRE	-	-	-	-	-	-
C-F-2 C5.60 2	V2 21302-034-5 21302-034-5 1302	ISI/UT/	ISI-21302-034 4" VALVE TO PIPE	ISI AUG OWN PRE	-	-	-	-	-	s
C-F-2 C5.60 2	V2 21302-034-6 21302-034-6 1302		ISI-21302-034 4" PIPE TO ELBOW	ISI AUG OWN PRE	-	-	-	-	-	-
C-F-2 C5.60 2	V2 21302-034-7 21302-034-7 1302		ISI-21302-034 4" ELBOW TO PIPE	ISI AUG OWN PRE	-	-	-	-	-	-
C-F-2 C5.60 2	V2 21302-034-8 21302-034-8 1302		ISI-21302-034 4" PIPE TO TEE	ISI AUG OWN PRE	-	-	-	-	-	-
C-F-2 C5.60 2	V2 21302-035-1 21302-035-1 1302		ISI-21302-029 4" VALVE TO PIPE	ISI AUG OWN PRE	-	-	-	-	-	-
C-F-2 C5.60 2	V2 21302-035-2 21302-035-2 1302		ISI-21302-029 4" PIPE TO FLOW ORIFICE	ISI AUG OWN PRE	-	-	-	-	-	-
C-F-2 C5.60 2	V2 21302-035-3 21302-035-3 1302		ISI-21302-029 4" FLOW ORIFICE TO PIPE	ISI AUG OWN PRE	-	-	-	-	-	-
C-F-2 C5.60 2	V2 21302-035-4 21302-035-4 1302		ISI-21302-029 4" PIPE TO VALVE	ISI AUG OWN PRE	-	-	-	-	-	-

Southern Nuclear Operating Company
3rd Interval
VOGTLE-2 ISI PLAN, VERSION 3.0

Category, Item No., Class	Summary No./CompID/System	Scope / Method / Procedure	Dwg/ISO No. Comp. Desc. Code Case		Period 1		Period 2			Period 3	
					2VR13	2VR14	2VR14A	2VR15	2VR16	2VR17	2VR18
C-F-2 C5.60 2	V2 21302-035-5 21302-035-5 1302		ISI-21302-029 4" VALVE TO PIPE	ISI AUG OWN PRE	- - - -	- - - -	- - - -	- - - -	- - - -	- - - -	- - - -
C-F-2 C5.60 2	V2 21302-035-6 21302-035-6 1302		ISI-21302-029 4" PIPE TO TEE	ISI AUG OWN PRE	- - - -	- - - -	- - - -	- - - -	- - - -	- - - -	- - - -
C-F-2 C5.60 2	V2 21302-036-1 21302-036-1 1302		ISI-21302-030 4" VALVE TO PIPE	ISI AUG OWN PRE	- - - -	- - - -	- - - -	- - - -	- - - -	- - - -	- - - -
C-F-2 C5.60 2	V2 21302-036-2 21302-036-2 1302		ISI-21302-030 4" PIPE TO ELBOW	ISI AUG OWN PRE	- - - -	- - - -	- - - -	- - - -	- - - -	- - - -	- - - -
C-F-2 C5.60 2	V2 21302-036-3 21302-036-3 1302		ISI-21302-030 4" ELBOW TO PIPE	ISI AUG OWN PRE	- - - -	- - - -	- - - -	- - - -	- - - -	- - - -	- - - -
C-F-2 C5.60 2	V2 21302-036-4 21302-036-4 1302		ISI-21302-030 4" PIPE TO FLOW ORIFICE	ISI AUG OWN PRE	- - - -	- - - -	- - - -	- - - -	- - - -	- - - -	- - - -
C-F-2 C5.60 2	V2 21302-036-5 21302-036-5 1302		ISI-21302-030 4" FLOW ORIFICE TO PIPE	ISI AUG OWN PRE	- - - -	- - - -	- - - -	- - - -	- - - -	- - - -	- - - -
C-F-2 C5.60 2	V2 21302-036-6 21302-036-6 1302		ISI-21302-030 4" PIPE TO VALVE	ISI AUG OWN PRE	- - - -	- - - -	- - - -	- - - -	- - - -	- - - -	- - - -
C-F-2 C5.60 2	V2 21302-036-7 21302-036-7 1302		ISI-21302-030 4" VALVE TO PIPE	ISI AUG OWN PRE	- - - -	- - - -	- - - -	- - - -	- - - -	- - - -	- - - -
C-F-2 C5.60 2	V2 21302-036-8 21302-036-8 1302		ISI-21302-030 4" PIPE TO TEE	ISI AUG OWN PRE	- - - -	- - - -	- - - -	- - - -	- - - -	- - - -	- - - -

Southern Nuclear Operating Company
3rd Interval
VOGTLE-2 ISI PLAN, VERSION 3.0

Category, Item No., Class	Summary No./CompID/System	Scope / Method / Procedure	Dwg/ISO No. Comp. Desc. Code Case		Period 1		Period 2			Period 3	
					2VR13	2VR14	2VR14A	2VR15	2VR16	2VR17	2VR18
C-F-2 C5.60 2	V2 21302-084-1 21302-084-1 1302	ISI/UT/	ISI-21302-030 3" TEE TO PIPE	ISI AUG OWN PRE	-	-	-	-	s	-	-
C-F-2 C5.60 2	V2 21302-084-10 21302-084-10 1302		ISI-21302-030 3" PIPE TO VALVE	ISI AUG OWN PRE	-	-	-	-	-	-	-
C-F-2 C5.60 2	V2 21302-084-2 21302-084-2 1302		ISI-21302-030 3" PIPE TO ELBOW	ISI AUG OWN PRE	-	-	-	-	-	-	-
C-F-2 C5.60 2	V2 21302-084-3 21302-084-3 1302		ISI-21302-030 3" ELBOW TO PIPE	ISI AUG OWN PRE	-	-	-	-	-	-	-
C-F-2 C5.60 2	V2 21302-084-4 21302-084-4 1302		ISI-21302-030 3" PIPE TO FLOW ELEMENT	ISI AUG OWN PRE	-	-	-	-	-	-	-
C-F-2 C5.60 2	V2 21302-084-5 21302-084-5 1302		ISI-21302-030 3" FLOW ELEMENT TO PIPE	ISI AUG OWN PRE	-	-	-	-	-	-	-
C-F-2 C5.60 2	V2 21302-084-6 21302-084-6 1302		ISI-21302-030 3" PIPE TO FLOW ORIFICE	ISI AUG OWN PRE	-	-	-	-	-	-	-
C-F-2 C5.60 2	V2 21302-084-7 21302-084-7 1302		ISI-21302-030 3" FLOW ORIFICE TO PIPE	ISI AUG OWN PRE	-	-	-	-	-	-	-
C-F-2 C5.60 2	V2 21302-084-8 21302-084-8 1302		ISI-21302-030 3" PIPE TO ELBOW	ISI AUG OWN PRE	-	-	-	-	-	-	-
C-F-2 C5.60 2	V2 21302-084-9 21302-084-9 1302		ISI-21302-030 3" ELBOW TO PIPE	ISI AUG OWN PRE	-	-	-	-	-	-	-

Southern Nuclear Operating Company
3rd Interval
VOGTLE-2 ISI PLAN, VERSION 3.0

Category, Item No., Class	Summary No./CompID/System	Scope / Method / Procedure	Dwg/ISO No. Comp. Desc. Code Case		Period 1		Period 2			Period 3			
					2VR13	2VR14	2VR14A	2VR15	2VR16	2VR17	2VR18		
C-F-2 C5.60 2	V2 21302-085-1 21302-085-1 1302	ISI/UT/	ISI-21302-085 3" TEE TO PIPE	ISI AUG OWN PRE	-	-	-	-	s	-	-	-	-
C-F-2 C5.60 2	V2 21302-085-10 21302-085-10 1302		ISI-21302-085 3" PIPE TO ELBOW	ISI AUG OWN PRE	-	-	-	-	-	-	-	-	-
C-F-2 C5.60 2	V2 21302-085-11 21302-085-11 1302		ISI-21302-085 3" ELBOW TO PIPE	ISI AUG OWN PRE	-	-	-	-	-	-	-	-	-
C-F-2 C5.60 2	V2 21302-085-12 21302-085-12 1302		ISI-21302-085 3" PIPE TO ELBOW	ISI AUG OWN PRE	-	-	-	-	-	-	-	-	-
C-F-2 C5.60 2	V2 21302-085-13 21302-085-13 1302		ISI-21302-085 3" ELBOW TO PIPE	ISI AUG OWN PRE	-	-	-	-	-	-	-	-	-
C-F-2 C5.60 2	V2 21302-085-14 21302-085-14 1302		ISI-21302-085 3" PIPE TO ELBOW	ISI AUG OWN PRE	-	-	-	-	-	-	-	-	-
C-F-2 C5.60 2	V2 21302-085-15 21302-085-15 1302		ISI-21302-085 3" ELBOW TO PIPE	ISI AUG OWN PRE	-	-	-	-	-	-	-	-	-
C-F-2 C5.60 2	V2 21302-085-16 21302-085-16 1302		ISI-21302-085 3" PIPE TO ELBOW	ISI AUG OWN PRE	-	-	-	-	-	-	-	-	-
C-F-2 C5.60 2	V2 21302-085-17 21302-085-17 1302		ISI-21302-085 3" ELBOW TO PIPE	ISI AUG OWN PRE	-	-	-	-	-	-	-	-	-
C-F-2 C5.60 2	V2 21302-085-18 21302-085-18 1302		ISI-21302-085 3" PIPE TO VALVE	ISI AUG OWN PRE	-	-	-	-	-	-	-	-	-

Southern Nuclear Operating Company
3rd Interval
VOGTLE-2 ISI PLAN, VERSION 3.0

Category, Item No., Class	Summary No./CompID/System	Scope / Method / Procedure	Dwg/ISO No. Comp. Desc. Code Case		Period 1		Period 2		Period 3	
					2VR13	2VR14	2VR14A	2VR15	2VR16	2VR17
C-F-2 C5.60 2	V2 21302-085-2 21302-085-2 1302		ISI-21302-085 3" PIPE TO ELBOW	ISI AUG OWN PRE	- - - -	- - - -	- - - -	- - - -	- - - -	- - - -
C-F-2 C5.60 2	V2 21302-085-3 21302-085-3 1302		ISI-21302-085 3" ELBOW TO PIPE	ISI AUG OWN PRE	- - - -	- - - -	- - - -	- - - -	- - - -	- - - -
C-F-2 C5.60 2	V2 21302-085-4 21302-085-4 1302		ISI-21302-085 3" PIPE TO ELBOW	ISI AUG OWN PRE	- - - -	- - - -	- - - -	- - - -	- - - -	- - - -
C-F-2 C5.60 2	V2 21302-085-5 21302-085-5 1302		ISI-21302-085 3" ELBOW TO PIPE	ISI AUG OWN PRE	- - - -	- - - -	- - - -	- - - -	- - - -	- - - -
C-F-2 C5.60 2	V2 21302-085-6 21302-085-6 1302		ISI-21302-085 3" PIPE TO FLOW ELEMENT	ISI AUG OWN PRE	- - - -	- - - -	- - - -	- - - -	- - - -	- - - -
C-F-2 C5.60 2	V2 21302-085-7 21302-085-7 1302		ISI-21302-085 3" FLOW ELEMENT TO PIPE	ISI AUG OWN PRE	- - - -	- - - -	- - - -	- - - -	- - - -	- - - -
C-F-2 C5.60 2	V2 21302-085-8 21302-085-8 1302		ISI-21302-085 3" PIPE TO FLOW ORIFICE	ISI AUG OWN PRE	- - - -	- - - -	- - - -	- - - -	- - - -	- - - -
C-F-2 C5.60 2	V2 21302-085-9 21302-085-9 1302		ISI-21302-085 3" FLOW ORIFICE TO PIPE	ISI AUG OWN PRE	- - - -	- - - -	- - - -	- - - -	- - - -	- - - -
C-F-2 C5.60 2	V2 21302-086-1 21302-086-1 1302	ISI/UT/	ISI-21302-086 3" TEE TO PIPE	ISI AUG OWN PRE	- - - -	- - - -	- - - -	s - - -	- - - -	- - - -
C-F-2 C5.60 2	V2 21302-086-10 21302-086-10 1302		ISI-21302-086 3" PIPE TO ELBOW	ISI AUG OWN PRE	- - - -	- - - -	- - - -	- - - -	- - - -	- - - -

Southern Nuclear Operating Company
3rd Interval
VOGTLE-2 ISI PLAN, VERSION 3.0

Category, Item No., Class	Summary No./CompID/System	Scope / Method / Procedure	Dwg/ISO No. Comp. Desc. Code Case		Period 1		Period 2			Period 3	
					2VR13	2VR14	2VR14A	2VR15	2VR16	2VR17	2VR18
C-F-2 C5.60 2	V2 21302-086-11 21302-086-11 1302		ISI-21302-086 3" ELBOW TO PIPE	ISI AUG OWN PRE	-	-	-	-	-	-	-
C-F-2 C5.60 2	V2 21302-086-12 21302-086-12 1302		ISI-21302-086 3" PIPE TO VALVE	ISI AUG OWN PRE	-	-	-	-	-	-	-
C-F-2 C5.60 2	V2 21302-086-2 21302-086-2 1302	ISI/UT/	ISI-21302-086 3" PIPE TO ELBOW	ISI AUG OWN PRE	-	-	-	s	-	-	-
C-F-2 C5.60 2	V2 21302-086-3 21302-086-3 1302		ISI-21302-086 3" ELBOW TO PIPE	ISI AUG OWN PRE	-	-	-	-	-	-	-
C-F-2 C5.60 2	V2 21302-086-4 21302-086-4 1302		ISI-21302-086 3" PIPE TO FLOW ELEMENT	ISI AUG OWN PRE	-	-	-	-	-	-	-
C-F-2 C5.60 2	V2 21302-086-5 21302-086-5 1302		ISI-21302-086 3" FLOW ELEMENT TO PIPE	ISI AUG OWN PRE	-	-	-	-	-	-	-
C-F-2 C5.60 2	V2 21302-086-6 21302-086-6 1302		ISI-21302-086 3" PIPE TO FLOW ORIFICE	ISI AUG OWN PRE	-	-	-	-	-	-	-
C-F-2 C5.60 2	V2 21302-086-7 21302-086-7 1302		ISI-21302-086 3" FLOW ORIFICE TO PIPE	ISI AUG OWN PRE	-	-	-	-	-	-	-
C-F-2 C5.60 2	V2 21302-086-8 21302-086-8 1302		ISI-21302-086 3" PIPE TO ELBOW	ISI AUG OWN PRE	-	-	-	-	-	-	-
C-F-2 C5.60 2	V2 21302-086-9 21302-086-9 1302		ISI-21302-086 3" ELBOW TO PIPE	ISI AUG OWN PRE	-	-	-	-	-	-	-

**Southern Nuclear Operating Company
3rd Interval
VOGTLE-2 ISI PLAN, VERSION 3.0**

Category, Item No., Class	Summary No./ComplD/System	Scope / Method / Procedure	Dwg/ISO No. Comp. Desc. Code Case		Period 1		Period 2		Period 3													
					2VR13	2VR14	2VR14A	2VR15	2VR16	2VR17	2VR18											
C-F-2 C5.60 2	V2 21302-087-1 21302-087-1 1302		ISI-21302-029 3" TEE TO PIPE	ISI AUG OWN PRE	-	-	-	-	-	-	-	-	-	-	-	-	-	-	-	-	-	-
C-F-2 C5.60 2	V2 21302-087-10 21302-087-10 1302		ISI-21302-029 3" PIPE TO VALVE	ISI AUG OWN PRE	-	-	-	-	-	-	-	-	-	-	-	-	-	-	-	-	-	-
C-F-2 C5.60 2	V2 21302-087-2 21302-087-2 1302		ISI-21302-029 3" PIPE TO ELBOW	ISI AUG OWN PRE	-	-	-	-	-	-	-	-	-	-	-	-	-	-	-	-	-	-
C-F-2 C5.60 2	V2 21302-087-3 21302-087-3 1302		ISI-21302-029 3" ELBOW TO PIPE	ISI AUG OWN PRE	-	-	-	-	-	-	-	-	-	-	-	-	-	-	-	-	-	-
C-F-2 C5.60 2	V2 21302-087-4 21302-087-4 1302		ISI-21302-029 3" PIPE TO FLOW ELEMENT	ISI AUG OWN PRE	-	-	-	-	-	-	-	-	-	-	-	-	-	-	-	-	-	-
C-F-2 C5.60 2	V2 21302-087-5 21302-087-5 1302		ISI-21302-029 3" FLOW ELEMENT TO PIPE	ISI AUG OWN PRE	-	-	-	-	-	-	-	-	-	-	-	-	-	-	-	-	-	-
C-F-2 C5.60 2	V2 21302-087-6 21302-087-6 1302		ISI-21302-029 3" PIPE TO FLOW ORIFICE	ISI AUG OWN PRE	-	-	-	-	-	-	-	-	-	-	-	-	-	-	-	-	-	-
C-F-2 C5.60 2	V2 21302-087-7 21302-087-7 1302		ISI-21302-029 3" FLOW ORIFICE TO PIPE	ISI AUG OWN PRE	-	-	-	-	-	-	-	-	-	-	-	-	-	-	-	-	-	-
C-F-2 C5.60 2	V2 21302-087-8 21302-087-8 1302		ISI-21302-029 3" PIPE TO ELBOW	ISI AUG OWN PRE	-	-	-	-	-	-	-	-	-	-	-	-	-	-	-	-	-	-
C-F-2 C5.60 2	V2 21302-087-9 21302-087-9 1302		ISI-21302-029 3" ELBOW TO PIPE	ISI AUG OWN PRE	-	-	-	-	-	-	-	-	-	-	-	-	-	-	-	-	-	-

**Southern Nuclear Operating Company
3rd Interval
VOGTLE-2 ISI PLAN, VERSION 3.0**

Category, Item No., Class	Summary No./CompID/System	Scope / Method / Procedure	Dwg/ISO No. Comp. Desc. Code Case		Period 1		Period 2		Period 3	
					2VR13	2VR14	2VR14A	2VR15	2VR16	2VR17
C-F-2	V2 21305-058-2		ISI-21305-058 16" PIPE TO 6" BRANCH CONNECTION (TS 5.5.16)	ISI	-	-	-	-	-	-
C5.81 2	21305-058-2 1305			AUG OWN PRE	-	-	-	-	-	-
C-F-2	V2 21305-060-2	ISI/UT/NMP-ES-024-502	ISI-21305-060 16" PIPE TO 6" BRANCH CONNECTION (TS 5.5.16)	ISI	-	s	-	-	-	-
C5.81 2	21305-060-2 1305			AUG OWN PRE	-	-	-	-	-	-
C-F-2	V2 21305-062-4		ISI-21305-062 16" PIPE TO 6" BRANCH CONNECTION (TS 5.5.16)	ISI	-	-	-	-	-	-
C5.81 2	21305-062-4 1305			AUG OWN PRE	-	-	-	-	-	-
C-F-2	V2 21305-064-2		ISI-21305-064 16" PIPE TO 6" BRANCH CONNECTION (TS 5.5.16)	ISI	-	-	-	-	-	-
C5.81 2	21305-064-2 1305			AUG OWN PRE	-	-	-	-	-	-

**VOGTLE UNIT 2 THIRD INTERVAL ISI PLAN
AUGMENTED EXAMINATIONS**

EXAMINATION OF INCONEL WELDS AND MATERIAL

Per the implementation protocol of the NEI 03-08 initiative, the below listed MRP-139 requirements are considered mandatory. MRP-139 was issued by letter dated September 12, 2005 (MRP 2004-05) and revised by letter dated November 1, 2007 (MRP 2007-038). In the November 1, 2007 letter, the MRP issued additional guidance (mandatory) for volumetric examination of small diameter dissimilar metal (DM) welds. This letter required that DM butt welds greater than or equal to 2" NPS but less than 4" NPS that are at *pressurizer or hot leg temperatures* (see Category D) be examined by December 31, 2010. An additional requirement applied to small diameter DM welds with an ECCS function, but this is not applicable to VEGP-2.

MRP Exams:

MRP-139 Category A Welds – Welds made from PWSCC resistant material. PWSCC Category A welds shall be inspected according to a schedule consistent with Section XI or an approved alternative. Not applicable to VEGP-2 at this time.

MRP-139 Category B Welds – PWSCC susceptible welds made from non-resistant material, that have no known cracks using qualified UT techniques, and are overlaid with a full-structural overlay made of PWSCC resistant material. Not applicable to VEGP-2 at this time.

MRP-139 Category C Welds - PWSCC susceptible welds made from non-resistant material, that have no known cracks using qualified UT techniques, and are treated with an acceptable stress improvement process. Not applicable to VEGP-2 at this time.

MRP-139 Category D Welds - PWSCC susceptible welds $\geq 2''$ diameter made from non-resistant material that are not treated with an acceptable stress improvement process, and are subject to pressurizer or hot leg temperatures (that can be examined). Included are the four RPV hot leg safe-end welds (the pressurizer welds are overlaid). The MRP requirements are for the four hot leg welds to have an initial qualified UT examination by 12/31/2009 and then be re-examined every 5 years. These welds were examined during 2R12 (Spring 2007) to meet the initial qualified UT examination requirement. They will be re-examined during 2R15 (Fall 2011) and subsequently re-examined during 2R18 (Spring 2016) to meet the 5 year re-examination requirement. *These welds are designated as Category B-F, Item B5.10 in ScheduleWorks.*

MRP-139 Category E Welds - PWSCC susceptible welds $\geq 4''$ diameter made from non-resistant material that are not treated with an acceptable stress improvement process, and are subject to cold leg temperatures. Included are the four RPV cold leg safe-end welds. The MRP requirements are for the four cold leg welds to have an initial qualified UT examination by 12/31/2010 and then be re-examined every 6 years. These welds were examined during 2R12 (Spring 2007) which met the initial qualified UT examination requirement and they will be re-examined during 2R15 (Fall 2011) and subsequently re-examined during 2R18 (Spring 2016) to meet the first 6 year re-examination requirement. *These welds are designated as Category B-F, Item B5.10 in ScheduleWorks.*

VOGTLE UNIT 2 THIRD INTERVAL ISI PLAN AUGMENTED EXAMINATIONS

MRP-139 Category F Welds – PWSCC susceptible welds made from non-resistant material, that have known cracks, that were overlaid with a full-structural overlay made of PWSCC resistant material, and then had a post-overlay examination. Not applicable to VEGP-2 at this time.

MRP-139 Category G Welds - PWSCC susceptible welds made from non-resistant material, that contain known cracks. Not applicable to VEGP-2 at this time.

MRP-139 Category H Welds - PWSCC susceptible welds made from non-resistant material that cannot be volumetrically examined and are exposed to hot leg or pressurizer temperatures. Not applicable to VEGP-2 because the four pressurizer safety/relief nozzle to safe end welds have been overlaid.

MRP-139 Category I Welds - PWSCC susceptible welds made from non-resistant material that cannot be volumetrically examined and are exposed to cold leg temperatures. Not applicable to VEGP-2 at this time.

MRP-139 Category J Welds– PWSCC susceptible welds ≥ 2 " diameter made from non-resistant material that have not been mitigated, and are subject to *hot leg temperatures*. MRP-139 Category J welds (Code Case N-722, Item B15.90) must have a BMV every outage unless a UT examination is being performed. These welds were examined during 2R12 (Spring 2007) to meet the initial qualified UT examination requirement. They will be UT examined during 2R15 (Fall 2011) and subsequently re-examined during 2R18 (Spring 2016) to meet the 5 year re-examination requirement. (See Code Case N-722 for additional requirements).

MRP-139 Category K Cold Leg Welds (N-722, Item B15.95) - PWSCC susceptible welds ≥ 4 " diameter made from non-resistant material and are subject to cold leg temperatures. Category K welds must have a BMV every three outages. However, in refueling outages where the UT is performed, a BMV may be credited if the examination is performed from the OD or if 90% of the examination volume is examined from the ID. For VEGP-2, a UT (from the ID with greater than 90% coverage) was performed during 2R12. The next BMV examination would then be required in 2R15; however, a UT will be performed during 2R15. Credit will be taken for the UT (as a BMV examination) in 2R15 as allowed above. The next BMV would then be due during 2R18; however, a UT is scheduled for 2R18. Therefore, no additional BMV examinations are required during the 3rd Interval. (See Code Case N-722 for additional requirements).

NRC Rulemaking To Implement Code Case N-722

Paragraph 10 CFR 50.55a(g)(6)(ii)(E) was added to 10 CFR 50.55a by a Final Rulemaking effective October 10, 2008 requires that *visual examinations* be performed on the reactor coolant pressure boundary. For inspections to be conducted every refueling outage and inspections conducted every other refueling outage, the initial inspection shall be performed at the next refueling outage after January 1, 2009. For inspections to be conducted once per interval, the inspections shall begin in the interval in effect on January 1, 2009, and shall be prorated over the remaining periods and refueling outages in this interval. The requirements are as follows:

**VOGTLE UNIT 2 THIRD INTERVAL ISI PLAN
AUGMENTED EXAMINATIONS**

- 10 CFR 50.55a(g)(6)(ii)(E)(1) All licensees of pressurized water reactors shall augment their inservice inspection program by implementing ASME Code Case N-722 subject to the conditions specified in paragraphs 10 CFR 50.55a(g)(6)(ii)(E)(2) through (4) of this section. The inspection requirements of ASME Code Case N-722 do not apply to components with pressure retaining welds fabricated with Alloy 600/82/182 materials that have been mitigated by weld overlay or stress improvement.
- 10 CFR 50.55a(g)(6)(ii)(E)(2) If a visual examination determines that leakage is occurring from a specific item listed in Table 1 of ASME Code Case N-722 that is not exempted by the ASME Code, Section XI, IWB-1220(b)(1), additional actions must be performed to characterize the location, orientation, and length of crack(s) in Alloy 600 nozzle wrought material and location, orientation, and length of crack(s) in Alloy 82/182 butt welds. Alternatively, licensees may replace the Alloy 600/82/182 materials in all the components under the item number of the leaking component.
- 10 CFR 50.55a(g)(6)(ii)(E)(3) If the actions in paragraph 10 CFR 50.55a(g)(6)(ii)(E)(2) of this section determine that a flaw is circumferentially oriented and potentially a result of primary water stress corrosion cracking, licensees shall perform non-visual NDE inspections of components that fall under that ASME Code Case N-722 item number. The number of components inspected must equal or exceed the number of components found to be leaking under that item number. If circumferential cracking is identified in the sample, non-visual NDE must be performed in the remaining components under that item number.
- 10 CFR 50.55a(g)(6)(ii)(E)(4) If ultrasonic examinations of butt welds are used to meet the NDE requirements in paragraphs 10 CFR 50.55a(g)(6)(ii)(E)(2) or 10 CFR 50.55a(g)(6)(ii)(E)(3) of this section, they must be performed using the appropriate supplement of Section XI, Appendix VIII of the ASME Boiler and Pressure Vessel Code.

This new rulemaking overlaps the requirements of MRP-139 in some cases. When there are conflicting requirements, SNC will use the most conservative requirement. Table 1 shows a comparison of the visual exam requirements of N-722 versus those of MRP-139.

**VOGTLE UNIT 2 THIRD INTERVAL ISI PLAN
AUGMENTED EXAMINATIONS**

Table 1 Bare Metal Visual (BMV) Examinations				
N-722 Item	Description	N-722 BMV Frequency	MRP-139 BMV Frequency	Comments
B15.80	RPV bottom-mounted instrument penetrations	Every other RO	NA	SNC has elected to perform a BMV each RO
B15.90	RPV Hot leg nozzle-to-pipe connections	Each RO	Each RO	Same as MRP 139, Cat. J
B15.95	RPV Cold leg nozzle-to-pipe connections	Once per interval	Once per interval	MRP letter 2009-031 changed the MRP-139 BMV frequency to match N-722.
B15.120	SG Bottom channel head drain tube penetration	Once per interval	None	VEGP has elected to perform a visual exam each RO. See WCAP-12907.
B15.150	PZR Spray nozzle-to-pipe connections	NA to VEGP-2	NA to VEGP-2	Overlaid
B15.160	PZR Safety/relief nozzle-to-pipe connections	NA to VEGP-2	NA to VEGP-2	Overlaid
B15.100	RPV Instrument connections	NA to VEGP-2	NA to VEGP-2	Not Alloy 600/82/182
B15.110	SG Hot leg nozzle-to-pipe connections	NA to VEGP-2	NA to VEGP-2	Not Alloy 600/82/182
B15.115	SG Cold leg nozzle-to-pipe connections	NA to VEGP-2	NA to VEGP-2	Not Alloy 600/82/182
B15.130	SG Primary side hot leg instrument connections	NA to VEGP-2	NA to VEGP-2	Not Alloy 600/82/182
B15.135	SG Primary side cold leg instrument connections	NA to VEGP-2	NA to VEGP-2	Not Alloy 600/82/182
B15.140	PZR Heater penetrations	NA to VEGP-2	NA to VEGP-2	Not Alloy 600/82/182
B15.170	PZR Surge nozzle-to-pipe connections	NA to VEGP-2	NA to VEGP-2	Overlaid
B15.180	PZR Instrument connections	NA to VEGP-2	NA to VEGP-2	Not Alloy 600/82/182
B15.190	PZR Drain nozzle-to-pipe connections	NA to VEGP-2	NA to VEGP-2	NA to VEGP
B15.200	Hot leg piping instrument connections	NA to VEGP-2	NA to VEGP-2	Not Alloy 600/82/182
B15.205	Cold leg piping instrument connections	NA to VEGP-2	NA to VEGP-2	Not Alloy 600/82/182
B15.210	Hot leg piping full penetration welds	NA to VEGP-2	NA to VEGP-2	Not Alloy 600/82/182
B15.215	Cold leg piping full penetration welds	NA to VEGP-2	NA to VEGP-2	Not Alloy 600/82/182

As shown in Table 1, only Code Case N-722, Items B15.80, B15.90, B15.95, and B15.120 are applicable to VEGP-2. These items are discussed below

Code Case N-722, Item B15.80 RPV Bottom-Mounted Instrument Penetrations – The requirement is to perform a BMV examination every other refueling outage. SNC has elected to perform a BMV examination every refueling outage. A decision was made to designate these welds as Category N-722, Item B15.80 in ScheduleWorks.

**VOGTLE UNIT 2 THIRD INTERVAL ISI PLAN
AUGMENTED EXAMINATIONS**

N-722, Item B15.90 – PWSCC susceptible welds subject to *hot leg temperatures*. Both MRP-139 Category J welds and Code Case N-722, Item B15.90 require a BMV every outage unless a UT examination is being performed. These welds were examined during 2R12 (Spring 2007) to meet the initial qualified UT examination requirement. They will be UT examined during 2R15 (Fall 2011) and subsequently re-examined during 2R18 (Spring 2016) to meet the 5 year re-examination requirement. Therefore, BMV examinations are required during 2R13 (Fall 2008), 2R14 (Spring 2010), 2R16 (Spring 2013), and 2R17 (Fall 2014). The N-722, Item B15.90 examination requirements are the same as the MRP requirements. A decision was made to preemptively designate these welds as Category N-722, Item B15.90 in ScheduleWorks.

N-722, Item B15.95 - PWSCC susceptible weld subject to *cold leg temperatures*. Code Case N-722, Item B15.95 requires a BMV once per interval unless a UT examination is being performed, while MRP-139 Category J welds require a BMV every third outage unless a UT examination is being performed. Therefore, the requirement for VEGP-2 will be to perform a BMV every 3rd outage unless a UT examination is performed. For VEGP-2, a UT examination (from the ID with greater than 90% coverage) was performed during 2R12 (Spring 2007) which met the initial qualified UT examination requirement. The BMV would be required during 2R15; however, the welds will be UT examined during 2R15 (Fall 2011) to meet the first 6 year re-examination requirement. Therefore, BMV examinations are not required during 2R13 (Fall 2008) or 2R14 (Spring 2010). Three outages from 2R15 is 2R18; however, the automated RPV examinations are scheduled for 2R18 and the UT of the cold legs welds will be performed. Therefore, no additional BMV examinations are required during the 3rd Interval. These examinations are designated as Category N-722, Item B15.95 in ScheduleWorks.

WCAP-12907 (N-722, Item B15.120) – SNC has elected to examine each of the four SG Bottom channel head drain tube penetrations each refueling outage. See WCAP-12907. A decision was made to preemptively designate these as Category N-722, Item B15.120 in ScheduleWorks.

Partition Plate - - SNC has elected to examine each of the four SG partition plates every 10-year interval. See WCAP-12907. These welds are designated as Category SG-PP, Item VT in ScheduleWorks.

**VOGTLE UNIT 2 THIRD INTERVAL ISI PLAN
AUGMENTED EXAMINATIONS**

Code Case N-729-1 Exams:

NRC Regulations

Volume 73 of the Federal Register, No. 176, dated September 10, 2008 incorporated a Final Rule to require expedited implementation of Code Case N-729-1, Alternate Examination Requirements for PWR Reactor Vessel Upper Heads with Nozzles having Partial-Penetration Welds.

The effective date for the rulemaking was listed as October 10, 2008; however, 10 CFR 50.55a(g)(6)(ii)(D) states that the initial inspections for this Code Case are to be performed in the refueling outage after December 31, 2008. In the case of Vogtle-2, the implementation will be the 2R14 outage starting in March 2010.

Paragraph 10 CFR 50.55a(g)(ii)(D) states:

10 CFR 50.55a(g)(6)(ii)(D) *Reactor Vessel Head Inspections.*

10 CFR 50.55a(g)(6)(ii)(D)(1) - All licensees of pressurized water reactors shall augment their inservice inspection program with ASME Code Case N-729-1 subject to the conditions specified in paragraphs (g)(6)(ii)(D)(2) through (6) of this section. Licensees of existing operating reactors as of September 10, 2008 shall implement their augmented inservice inspection program by December 31, 2008. Once a licensee implements this requirement, the First Revised NRC Order EA-03-009 no longer applies to that licensee and shall be deemed to be withdrawn.

10 CFR 50.55a(g)(6)(ii)(D)(2) - Note 9 of ASME Code Case N-729-1 shall not be implemented.

10 CFR 50.55a(g)(6)(ii)(D)(3) - Instead of the specified 'examination method' requirements for volumetric and surface examinations in Note 6 of Table 1 of Code Case N-729-1, the licensee shall perform volumetric and/or surface examination of essentially 100 percent of the required volume or equivalent surfaces of the nozzle tube, as identified by Figure 2 of ASME Code Case N-729-1. A demonstrated volumetric or surface leak path assessment through all J-groove welds shall be performed. If a surface examination is being substituted for a volumetric examination on a portion of a penetration nozzle that is below the toe of the J-groove weld [Point E on Figure 2 of ASME Code Case N-729-1], the surface examination shall be of the inside and outside wetted surface of the penetration nozzle not examined volumetrically.

10 CFR 50.55a(g)(6)(ii)(D)(4) - By September 1, 2009, ultrasonic examinations shall be performed using personnel, procedures and equipment that have been qualified by blind demonstration on representative mockups using a methodology that meets the conditions specified in (50.55a(g)(6)(ii)(D)(3)(i) through (50.55a(g)(6)(ii)(D)(4)(iv), instead of the qualification requirements of Paragraph -2500 of ASME Code Case N-729-1. References herein to Section XI, Appendix VIII shall be to the 2004 Edition with no Addenda of the ASME BPV Code.

**VOGTLE UNIT 2 THIRD INTERVAL ISI PLAN
AUGMENTED EXAMINATIONS**

10 CFR 50.55a(g)(6)(ii)(D)(4)(i) - The specimen set shall have an applicable thickness qualification range of +25 percent to -40 percent for nominal depth through-wall thickness. The specimen set shall include geometric and material conditions that normally require discrimination from primary water stress corrosion cracking (PWSCC) flaws.

10 CFR 50.55a(g)(6)(ii)(D)(4)(ii) - The specimen set shall have a minimum of ten (10) flaws which provide an acoustic response similar to PWSCC indications. All flaws shall be greater than 10 percent of the nominal pipe wall thickness. A minimum of 20 percent of the total flaws shall initiate from the inside surface and 20 percent from the outside surface. At least 20 percent of the flaws shall be in the depth ranges of 10–30 percent through wall thickness and at least 20 percent within a depth range of 31–50 percent through wall thickness. At least 20 percent and no more than 40 percent of the flaws shall be oriented axially.

10 CFR 50.55a(g)(6)(ii)(D)(4)(iii) - Procedures shall identify the equipment and essential variables and settings used for the qualification, and are consistent with Subarticle VIII–2100 of Section XI, Appendix VIII. The procedure shall be requalified when an essential variable is changed outside the demonstration range as defined by Subarticle VIII–3130 of Section XI, Appendix VIII and as allowed by Articles VIII–4100, VIII–4200 and VIII–4300 of Section XI, Appendix VIII. Procedure qualification shall include the equivalent of at least three personnel performance demonstration test sets. Procedure qualification requires at least one successful personnel performance demonstration.

10 CFR 50.55a(g)(6)(ii)(D)(4)(iv) - Personnel performance demonstration test acceptance criteria shall meet the personnel performance demonstration detection test acceptance criteria of Table VIII—S10–1 of Section XI, Appendix VIII, Supplement 10. Examination procedures, equipment, and personnel are qualified for depth sizing and length sizing when the RMS error, as defined by Subarticle VIII–3120 of Section XI, Appendix VIII, of the flaw depth measurements, as compared to the true flaw depths, do not exceed 1/8 inch (3 mm), and the root mean square (RMS) error of the flaw length measurements, as compared to the true flaw lengths, do not exceed 3/8 inch (10 mm), respectively.

10 CFR 50.55a(g)(6)(ii)(D)(5) - If flaws attributed to PWSCC have been identified, whether acceptable or not for continued service under Paragraphs –3130 or –3140 of ASME Code Case N–729–1, the re-inspection interval must be each refueling outage instead of the re-inspection intervals required by Table 1, Note (8) of ASME Code Case N–729–1.

10 CFR 50.55a(g)(6)(ii)(D)(6) - Appendix I of ASME Code Case N–729–1 shall not be implemented without prior NRC approval.

SNC Implementation

Category N-729, Item B4.10BMV - Every *third* outage a direct examination of the bare-metal surface (BMV) of the entire outer surface of the head including essentially 100% of the intersection of each nozzle with the head will be performed. The last BMV was performed during 2R13 (Fall

**VOGTLE UNIT 2 THIRD INTERVAL ISI PLAN
AUGMENTED EXAMINATIONS**

2008); therefore, the next examination is due 2R16 and 2R19. The following conditions apply to the examination:

- If welded or bolted obstructions are present (i.e., mirror insulation, insulation support feet, shroud support ring/lug), the examination shall include $\geq 95\%$ of the area in the region of the nozzles as defined in Figure 1 and the head surface uphill and downhill of any such obstructions.
- The examination may be performed with the system depressurized.
- The examination may be performed with the insulation in place using remote equipment that provides resolution of the component metal surface equivalent to a bare-metal direct examination.
- The examination shall be performed with an illumination level and a sufficient distance to allow resolution of lower case characters not greater than 0.105 in. in height.
- Personnel performing the BMV shall be qualified as a VT-2 visual examiner and shall have completed at least four (4) hr of additional training in detection of borated water leakage from UNS N06600, UNS N06082 or UNS W86182 components and the resulting boric acid corrosion of adjacent ferritic steel components.

Category N-729, Item B4.10VT2 – Every outage that a BMV is not being performed, perform an IWA-2212, VT-2 visual examination under the insulation through multiple access points. The examination is scheduled for 2R14, 2R15, 2R17, and 2R18. The examination may be performed with the system depressurized.

Category N-729, Item B4.20 - Based on Appendix 2 of NMP-ES-029-GL01, *Alloy 600 Program Strategic Plan*, the last UT/ECT examination was performed during 2R12 (Spring 2007) and the re-inspection frequency is every 6 calendar years. Therefore, the next examination will be in 2R16 (Spring 2013). The following requirements must be satisfied (along with other requirements in Code Case N-729-1 not described herein).

- Per 10 CFR 50.55a(g)(6)(ii)(D)(2), Footnote 9 may *not* be used to lengthen the 6 year re-inspection frequency.
- Per 10 CFR 50.55a(g)(6)(ii)(D)(5), if flaws attributed to PWSCC have been identified, whether acceptable or not for continued service, the re-inspection interval must be each refueling outage instead of the re-inspection intervals required by Footnote 8.
- Section -2500 of the Code Case states that, “Volumetric and surface examinations shall be qualified in accordance with the low rigor requirements of Article 14 of Section V.” 10 CFR 50.55a(g)(6)(ii)(D)(4) has specific requirements for qualification.
- Section -2500 of the Code Case states that, “If obstructions or limitations prevent examination of the volume or surface required by Fig. 2 for one or more nozzles, the analysis procedure of

**VOGTLE UNIT 2 THIRD INTERVAL ISI PLAN
AUGMENTED EXAMINATIONS**

Appendix I shall be used to demonstrate the adequacy of the examination volume or surface for each such nozzle. If Appendix I is used, the evaluation shall be submitted to the regulatory authority having jurisdiction at the plant site. 10 CFR 50.55a(g)(6)(ii)(D)(6) requires that Appendix I not be implemented without prior NRC approval.

- Item B4.20 requires that a volumetric examination of the nozzles be performed in accordance Figure 2 and Footnote 6. 10 CFR 50.55a(g)(6)(ii)(D)(3) requires that:
 - Instead of the specified 'examination method' requirements for volumetric and surface examinations listed in Footnote 6, the licensee shall perform volumetric and/or surface examination of essentially 100 percent of the required volume or equivalent surfaces of the nozzle tube, as identified by Figure 2 of ASME Code Case N-729-1.
 - A demonstrated volumetric or surface leak path assessment through all J-groove welds shall be performed.
 - If a surface examination is being substituted for a volumetric examination on a portion of a penetration nozzle that is below the toe of the J-groove weld [Point E on Figure 2 of ASME Code Case N-729-1], the surface examination shall be of the inside and outside wetted surface of the penetration nozzle not examined volumetrically".

**VOGTLE UNIT 2 THIRD INTERVAL ISI PLAN
AUGMENTED EXAMINATIONS**

**HIGH CYCLE THERMAL FATIGUE EXAMINATION IN THE NON-ISOLABLE REACTOR
COOLANT PRESSURE BOUNDARY (MRP-146)**

MRP-146, Management of Thermal Fatigue in Normally Stagnant Non-Isolable Reactor Coolant System Branch Lines, 101955, was issued in June 2005. MRP-146 contains recommendations classified as "needed" as defined by NEI 03-08 implementation protocol. Specifically, it required an evaluation to identify lines that are susceptible to thermal fatigue within two years from June 2005. This evaluation was performed and documented in RER C070655701 dated June 28, 2007. The following locations did not pass the screening criteria of Section 2 of MRP-146.

<u>Cold Leg Safety Injection Lines:</u>	<u>RCS Intermediate Leg Loop Drain Lines:</u>
21204-243-1.5"	21201-031-2"
21204-244-1.5"	21201-042-2"
21204-245-1.5"	21201-046-2"
21204-246-1.5"	21201-051-2"

MRP 2007-043 was issued on February 6, 2008 to require performance of initial inspections (in accordance with Section 2.4 of MRP-146) of lines that do not pass the screening criteria per sections 2.1.1/ 2.1.2.1/2.1.2.2 (UH/H) or 2.1.3/2.1.4.1/2.1.4.2 (DH). These examinations must be completed prior to the end of the next refueling outage that is initiated after January 31, 2009, which is 2R14 (Spring 2010). Initial inspections were performed as listed below.

Description	Segment	Weld Identifier	Comments
1.5" SI Cold Leg Loop 1	2RCS-059B	21204-243-31-RI	These welds were examined per MRP-146 requirements during 2R13 (Fall 2008). The base metal was examined per Fig 2-12 of MRP-146 while meeting the MRP-146 training requirements ⁽²⁾ . These examination satisfied the initial MRP-146 examinations. See Figure A below for a typical report.
1.5" SI Cold Leg Loop 2	2RCS-060B	21204-244-29-RI	
1.5" SI Cold Leg Loop 3	2RCS-061B	21204-245-30-RI	
1.5" SI Cold Leg Loop 4	2RCS-062B	21204-246-33-RI	
2" Drain Line Loop 1	2RCS-013	21201-031-3-RI	These welds were examined per MRP-146 requirements during 2R13 (Fall 2008). The base metal was examined per Fig 2-15 of MRP-146 while meeting the MRP-146 training requirements ⁽²⁾ . These examination satisfied the initial MRP-146 examinations. See Figure B below for a typical report.
2" Drain Line Loop 2	2RCS-014	21201-042-3-RI	
2" Drain Line Loop 3	2RCS-015	21201-046-3-RI	
2" Drain Line Loop 4	2RCS-016	21201-051-3-RI	

Note 1

An ultrasonic examination of the weld and base material as shown in Figure 2-12 or Figure 2-15 of MRP-146 shall be performed to the extent practical. The weld examination volume is shown in Figure 2-17 of MRP-146 for piping < 4" NPS and in Figure 2-18 of MRP-146 for piping ≥ 4" NPS. Since these examinations may be used for a future Risk-

VOGTLE UNIT 2 THIRD INTERVAL ISI PLAN AUGMENTED EXAMINATIONS

Informed ISI (RI-ISI) program the length for the examination volume (in Figure 2-17 or 2-18) shall be increased to include ½" beyond each side of the base metal thickness transition or counterbore.

Note 2

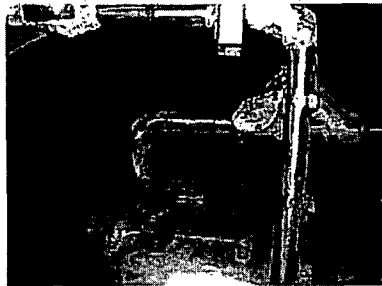
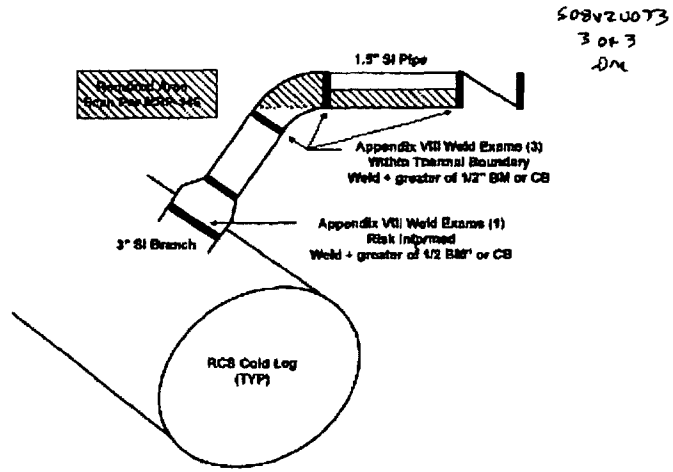
Since high-cycle thermal fatigue cracking is generally characterized by multiple initiation sites with the presence of crazing and fairly tight cracks, and may occur in either welds or base metal, examiners must be properly trained to assure they can detect high-cycle thermal fatigue cracking. The required training is:

- Have previous formal qualification for piping ultrasonic examination such as the ASME Code, Section XI Appendix VIII qualifications administered by PDI.
- Undergo a special indoctrination (approximately 4 hours) to familiarize examiners with the peculiarities of examination for high-cycle thermal fatigue damage and for geometric considerations specific to small diameter piping. To meet this requirement, a computer-based training module has been developed by EPRI (Computer-Based Training for Thermal Fatigue Cracking - MRP-38).

VOGTLE UNIT 2 THIRD INTERVAL ISI PLAN
AUGMENTED EXAMINATIONS

Figure A

Typical Examination Coverage and Photograph for 1.5" Safety Injection Lines



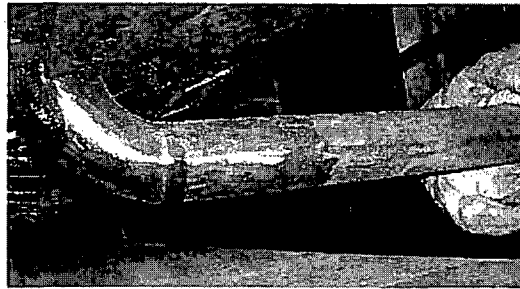
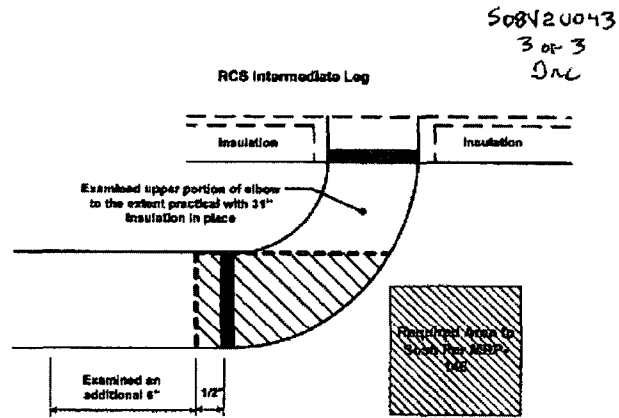
Typical of 4 loops

Examination individuals have met the training requirements of MRP-146.

VOGTLE UNIT 2 THIRD INTERVAL ISI PLAN
AUGMENTED EXAMINATIONS

Figure B

Typical Examination Coverage and Photograph for 2" Drain Lines



Typical of 4 loops

Examination individuals have met the training requirements of MRP-146.

VOGTLE UNIT 2 THIRD INTERVAL ISI PLAN
AUGMENTED EXAMINATIONS

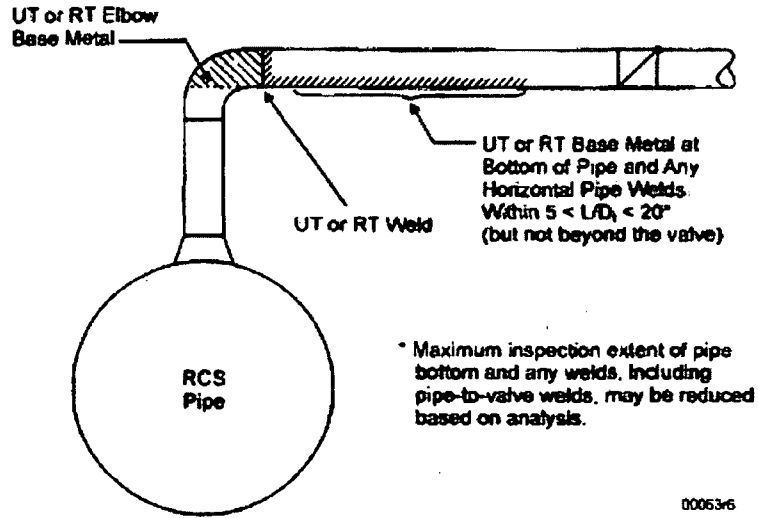
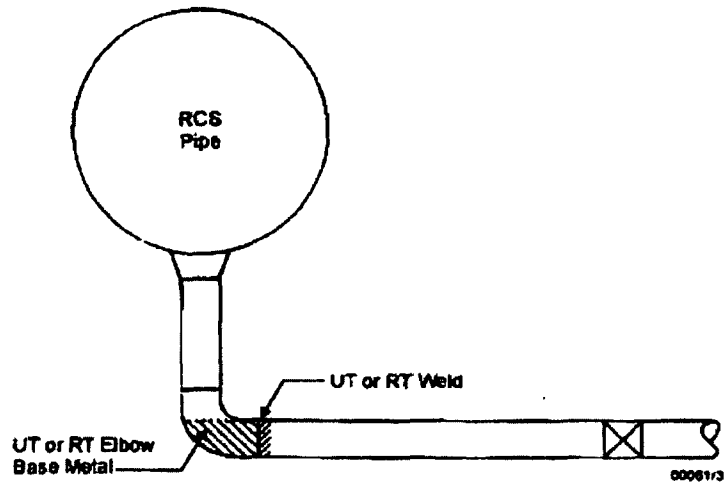


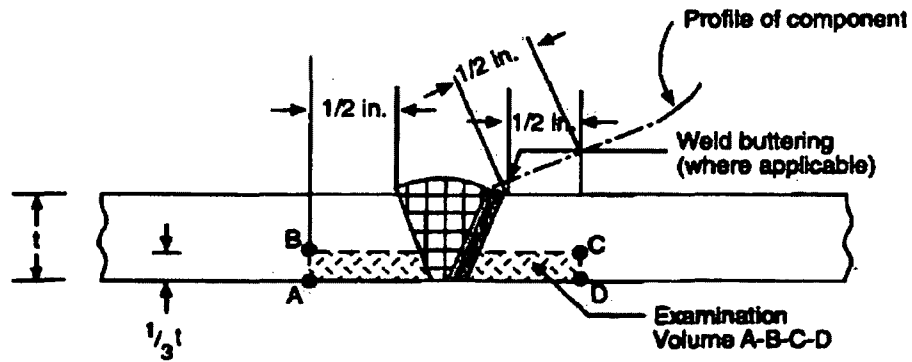
Figure 2-12
Examination Zones for Butt-Welded Lines Vertically Upward from RCS Piping

**VOGTLE UNIT 2 THIRD INTERVAL ISI PLAN
AUGMENTED EXAMINATIONS**

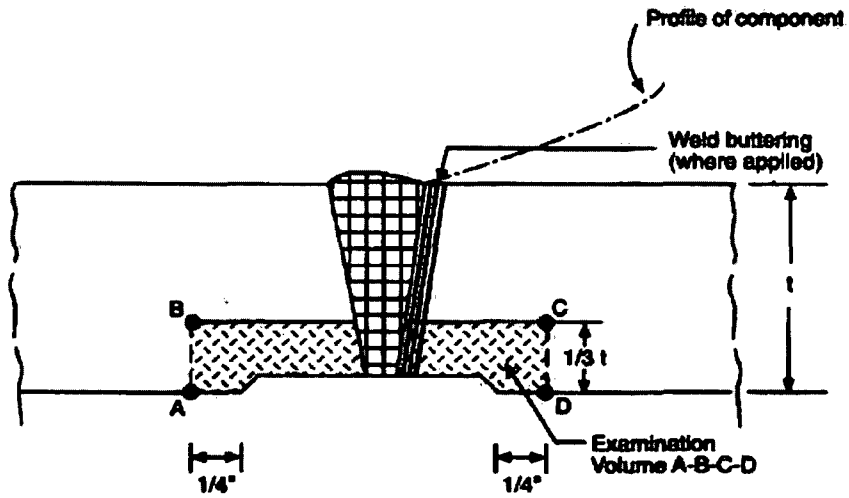


**Figure 2-15
Examination Zones for Butt-Welded Bottom Connected Lines**

**VOGTLE UNIT 2 THIRD INTERVAL ISI PLAN
AUGMENTED EXAMINATIONS**



**Figure 2-17
Examination Volume for Thermal Fatigue Cracking in Piping Welds Less than NPS 4 [14]**



**Figure 2-18
Examination Volume for Thermal Fatigue Cracking in Piping Welds NPS 4 or Larger [14]**

VOGTLE UNIT 2 THIRD INTERVAL ISI PLAN
AUGMENTED EXAMINATIONS

THERMAL FATIGUE EXAMINATIONS IN THE RHR SYSTEM

MRP letter 2007-011 (March 1, 2007) provided guidance for the implementation of MRP-192, *Assessment of RHR Mixing Tee Thermal Fatigue in PWR Plants – Good Practice Guidance*. The guidance was that MRP-192 contains recommendations classified as “good practice” as defined by NEI 03-08 implementation protocol. Each utility is expected to review the document for plant specific applicability, usefulness, and develop implementation plans for each of their units as needed and as governed by their internal Materials Degradation Management Program for “good practice” guidelines. As this guideline is a “good practice” document, reporting of deviations is not required.

The internal Materials Degradation Management Program for SNC is NMP-ES-030, which defines *Good Practice* as a recommendation from industry where implementation is expected to provide significant operational and reliability benefits, but the extent of use is at the discretion of the individual plant/utility. The Corporate Materials Supervisor, Manager Nuclear Fuel, or designee, accordingly, shall enter the work product into SyncPower and create Action Item (AI) assignments to ensure that review and evaluation of “Good Practice” work products are completed and any decisions to not implement are documented. No written justification is required for deviations to “Good Practice” elements.

Background

In 1998, a leak occurred from the Civaux 1 reactor residual heat removal system (RHRS) at the extrados of an elbow near the RHR heat exchangers [1-5]. Subsequent evaluation showed that the main through-wall crack with length of ~7 inches was due to thermal fatigue and that there were many other part-wall cracks in other regions of the piping immediately downstream of the RHR heat exchanger outlet mixing tee. The cracking at Civaux occurred in the extrados of a seam-welded elbow downstream of the mixing tee, as shown in Figure 2-1. Upon removal of the cracked elbow, a much larger degraded region was observed inside the piping.

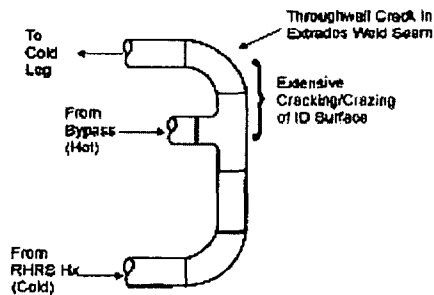
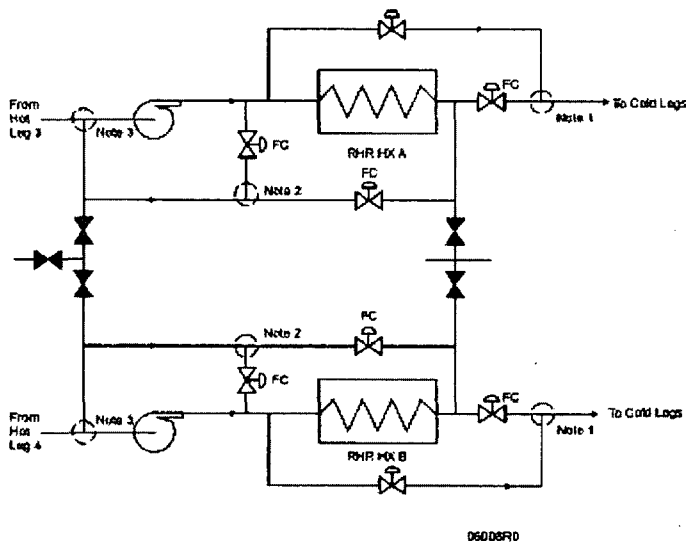


Figure 2-1

Examination of other locations showed that there was also cracking associated with the minimum flow lines (Note 2 in Figure 2-2). These are 4-inch lines with a wall thickness of 0.212 inches (5.4 mm – approximately Schedule 40). The cracking was generally less than 0.09 inches but some deeper cracks up to 0.20 inches (greater than 90% of wall thickness), were found [2]. The valves for

VOGTLE UNIT 2 THIRD INTERVAL ISI PLAN AUGMENTED EXAMINATIONS

the min-flow lines were of a configuration such that there was always some flow through the min-flow line. There was no specific cracking noted at the intersection of the minimum flow line upstream of the RHR pumps (Note 3 in Figure 2-2), but for this location, in the EDF plants the temperature difference would be less than for the location where cracking was noted in the minimum flow line.



- Notes: 1) Mixing tee location for bypass line (where through-wall cracking occurred at Civaux Unit 1 (Train A only), and where craze and/or partial through-wall cracking was observed in both of the Civaux and various other EDF units.)
 2) Mixing tee at location of intersection of two portions of minimum flow line (where craze cracking was observed at Civaux and various other EDF units.)
 3) Mixing tee where minimum flow line connects to RHR pump inlet (no mention was made of cracking at this location.)

Figure 2-2
Civaux RHR System Configuration and Cracking Locations.

Figure 2-2

The regions of fatigue damage were generally limited to about three pipe diameters from the weld between the mixing tees and downstream piping or other components. The observed cracking was immediately downstream of the mixing tee in a 10-inch Schedule 40 304L stainless steel seam-welded elbow. The worst cracking that led to the through-wall leak was at the extrados welded seam, and had an outside surface length of ~7 inches with an inside surface length of ~14 inches. The wall thickness was ~0.365 inches. The surrounding area of the elbow and locations between the elbow and the mixing tee exhibited widespread crazing-type cracking characteristic of thermal fatigue. Examination of this elbow and similar ones from other plants confirmed that high-cycle thermal fatigue was the mechanism. No fabrication defects were found. In general, the deep cracks (one through-wall at Civaux, and others up to 80 percent of the wall thickness) occurred along the longitudinal and circumferential welds, starting at the root of the weld on the inner surface. There were many small cracks, mainly in the weld counter-bore regions and where there was evidence of grinding.

**VOGTLE UNIT 2 THIRD INTERVAL ISI PLAN
AUGMENTED EXAMINATIONS**

MRP-192 Good Practice Recommendations for an Initial Examination

When the temperature differential across the RHR heat exchanger could exceed 144 °F:

- All RHR locations where hot and cold water can simultaneously enter a mixing tee should be determined. These will include bypass lines around the RHR heat exchanger and RHR pump minimum flow bypass lines. It should be assumed that significant leakage can occur through butterfly-type control valves while the RHR system is in operation. For other types of valves, it may be assumed that significant leakage will not occur.
- A system evaluation should be conducted to determine if mixing conditions at the identified locations will occur or have occurred during plant heatup and cooldown operations. The expected temperature difference across the RHR heat exchanger should be determined for these conditions.
- The need for an initial inspection at each identified mixing tee should be determined from Table 3-1 based on the Maximum Effective Operating Time and Maximum Elapsed Calendar Time limitations for that location. The effective operating hours to be compared to the Maximum Effective Operating Time is based on the number of hours of RHR operation and associated temperature differentials during past heatups and cooldowns (or any other plant conditions when RHR was in operation) when the temperature differential at the mixing tee could have exceeded 144 °F. Any plant that exceeds the Table 3-1 Maximum Effective Operating Time limitation (relative to any previous inspections satisfying the criteria below) should perform an inspection at the next outage. For plants that operate with an RHR temperature differential during heatup that is greater than 144 °F, an inspection should be conducted at the next outage if the Table 3-1 Maximum Elapsed Calendar Time since a previous inspection (satisfying the criteria below) is exceeded.

Table 3-1
Recommended Inspection Interval for Inspections Beyond ASME Section XI

Maximum RHR Heat Exchanger Inlet-to-Outlet Temperature Differential During Plant Heatup, ΔT_{in} (Note 2)	Inspection Interval (Note 1)	
	Maximum Effective Operating Time	Maximum Elapsed Calendar Time
$> 180^{\circ}\text{F}$ ($> 100^{\circ}\text{C}$)	450 hours	6 years
$144^{\circ}\text{F} < \Delta T_{in} \leq 180^{\circ}\text{F}$ ($80^{\circ}\text{C} < \Delta T_{in} \leq 100^{\circ}\text{C}$)	450 hours	10 years
$\leq 144^{\circ}\text{F}$ ($\leq 80^{\circ}\text{C}$)	400 hours	No Limit

- Notes: 1) The next inspection should be performed at the first occurrence of either the effective operating hours, N_{eff} , reaching the Maximum Effective Operating Time Inspection Interval or passage of the Maximum Elapsed Calendar Time Inspection Interval, except that the inspection may be performed at the next refueling outage after such limit is reached. N_{eff} , the effective operating hours, is calculated as described in Appendix A (Eq. A-2) based on the operating history since the last inspection.
- 2) The temperature differential, T_{diff} , is that during normal heatup operation with RHR in service, including periods with minimum service water temperature.

VOGTLE UNIT 2 THIRD INTERVAL ISI PLAN AUGMENTED EXAMINATIONS

Per MRP-192, the following locations were selected for a one-time examination for high-cycle thermal fatigue during the 2R13 outage (Fall 2008). These locations are in an Augmented Program designated as *Thermal Fatigue*.

These examinations were performed to the extent practical and the limitations to these examinations described on the data sheets. The individuals performing these examinations had documented thermal fatigue training. As noted below, two piping welds are actually listed under ASME Category C-F-1 for Code credit; however base material scanning was performed on these two welds to satisfy MRP-192 requirements.

LOCATION	MRP-192 EXAMINATION
21205-003-46-OE-UT Category = OE Item = MRP-192	Examined the base material of the 14" RHR Train "A" pump suction line from the 3" mini-flow return branch line (21205-013-3") to weld 49. Scope also included full Appendix VIII exams for welds 46, 47, 48. Weld 49 is shown under ISI Category C-F-1. See ISI-21205-003, Sheets 3 & 4.
21205-004-33-OE-UT Category = OE Item = MRP-192	Examined the base material of the 14" RHR Train "B" pump suction line from the 3" mini-flow return branch line (21205-014-3") to weld 36. Scope also included full Appendix VIII exams for welds 33, 34, 35. Weld 36 is shown under ISI Category C-F-1. See ISI-21205-004, Sheet 3.
21205-007-18 Category C-F-1 Item C5.11	Examined the accessible areas of the mixing tee and piping base material (31.9"). The scope also included a full Appendix VIII weld examination of weld 18. See ISI-21205-007, Sheets 1 & 2.
21205-008-17 Category C-F-1 Item C5.11	Examined the accessible areas of the mixing tee and piping base material (31.9"). The scope also included a full Appendix VIII weld examination of weld 17. See ISI-21205-008, Sheet 1.

Deviations to Table 1 Examination Requirements

Since the extent of use of MRP-192 is at the discretion of the individual plant/utility, the examinations in Table 1 were performed to the extent practical. The determination to remove supports or other interferences to improve coverage was at the discretion of the site.

Re-examination Requirements

An interval to the next inspection for affected mixing locations should also be determined from Table 3-1. The inspection interval (time between inspections) may be based on a best estimate of the number of hours of RHR operation and associated temperature differentials when the temperature differential at the mixing tee is expected to exceed 144 °F (80 °C) since the last inspection. Inspections should be performed no later than the next outage after the predicted Maximum Effective Operating Time or Maximum Elapsed Calendar Time limitations of Table 3-1 are exceeded. Alternately, the need for inspection may be based on monitoring of actual plant data. The actual time between inspections may be adjusted based on review of actual future operations. This inspection interval will be determined by the site.

**VOGTLE UNIT 2 THIRD INTERVAL ISI PLAN
AUGMENTED EXAMINATIONS**

EXAMINATION OF RC PUMP FLYWHEELS

Technical Specification 5.5.7 states, "This program shall provide for the inspection of *each* reactor coolant pump flywheel at least once per 10 years by conducting either:

- a. An in-place ultrasonic examination over the volume from the inner bore of the flywheel to the circle of one-half the outer radius; or
- b. A surface examination (magnetic particle and/or liquid penetrant) of exposed surfaces of the disassembled flywheel.

These examinations are designated as Category AUG, Item TS 5.5.7 in ScheduleWorks. The following criteria were used during the scheduling of the examinations during the 3rd Interval.

- To ensure TS 5.5.7 is met, the examinations shown in the 3rd interval were scheduled such that there is less than 10 years since the previous examinations were performed..
- If a flywheel is disassembled prior to the outage that it is scheduled in ScheduleWorks, a surface examination may be performed and ScheduleWorks changed to reflect the examination.
- Since the examination method is dependent upon whether the flywheel is disassembled, the examination method was not included.

Components are:

- 21201-P6-001-FW
- 21201-P6-002-FW
- 21201-P6-003-FW
- 21201-P6-004-FW

EXAMINATION OF PRESSURIZER HEATER SLEEVES

Vogtle is adding the pressurizer heater sleeves per WCAP-16913-P, Rev 1, which recommends these exams be performed every outage. Examinations consist of a VT-2 examination of the heater sleeves without insulation removed to detect evidence of leaking heater sleeves.

These exams are included in procedure NMP-ES-024-202. They will not be scheduled as an individual exam, but will be performed each outage.

**VOGTLE UNIT 2 THIRD INTERVAL ISI PLAN
AUGMENTED EXAMINATIONS**

HIGH ENERGY LINE BREAK (HELB) PIPING EXAMINATIONS

Per Section 3.6.2.1.1D of the Vogtle FSAR, areas of system piping where no breaks are postulated (break exclusion zone) are as follows:

- The main steam piping from the containment penetration flued head outboard weld to the upstream weld of the five-way restraint, which is downstream of the main steam isolation valves, including the main steam safety valves and branch piping to the main steam safety valves.
- The main feedwater piping from the containment penetration to the five-way restraint which is upstream of the isolation valve.

Per Vogtle Technical Specification 5.5.16 and Section 6.6.8 of the Vogtle FSAR, an augmented inservice inspection program is provided for high-energy fluid systems piping between containment isolation valves or where no isolation valve is used inside containment, between the first rigid pipe connection to the containment penetration or the first pipe whip restraint inside containment and the outside isolation valve. This program includes 100 percent volumetric examination of welds in the affected piping during each inspection interval and will be conducted in accordance with American Society of Mechanical Engineers (ASME) Code, Section XI, and covers the high-energy fluid systems described in subsections 3.6.1 and 3.6.2.

A Technical Specification change and LDCR is being submitted for Tech Spec 5.5.16 and FSAR Section 6.6.8 to allow Risk Informed (RI) methodology to be used for HELB Piping. The RI methodology will require a 10% sample scope. For 2R14, welds have been selected to meet the 10% sample scope and ASME Section XI Code requirements. All other examinations have been moved to 2R16. When the Tech Spec change and LDCR are approved the examinations moved to 2R16 will not be required. In addition, the scope for future outages will be changed to the 10% sample scope and incorporated into the plan after NRC approval.

These examinations will be designated as Category HELB, Item FW-BUTT for Feedwater welds and MS-BUTT for Main Steam welds. They are shown in Category C-F-2 if code credit is being taken.

**VOGTLE UNIT 2 THIRD INTERVAL ISI PLAN
AUGMENTED EXAMINATIONS**

APPENDIX Q WELD OVERLAY EXAMINATIONS

The pressurizer Alloy 82/182 pressurizer safe-end welds were overlaid during 2R12 (Spring 2007) per alternative ISI-GEN-ALT-06-03, Revision 2 which was approved per NRC safety evaluation reports (SER) (TAC Nos. MD2794, MD2795, MD2796 AND MD2797). By letter dated April 13, 2007 (NL-07-0803) committed to, "Perform subsequent ISI on the VEGP Unit 2 pressurizer FSWOLs in accordance with Q-4300 of Appendix Q to the 2004 Edition of Section XI with Addenda through 2005." Therefore, the welds were removed from the Risk-Informed ISI program and moved to this augmented program.

Dissimilar metal welds covered by the overlays were:

21201-V6-002-W17
21201-V6-002-W18
21201-V6-002-W19
21201-V6-002-W20
21201-V6-002-W21
21201-V6-002-W22

Adjacent similar metal welds also covered by the overlay were:

21201-030-49
21201-053-6
21201-056-1
21201-057-1
21201-058-1
21201-059-1

The component ID for the weld overlays are:

N1 NOZZLE	21201-058-WOL-1
N2 NOZZLE	21201-057-WOL-1
N3 NOZZLE	21201-056-WOL-1
N4 NOZZLE	21201-059-WOL-1
N5 NOZZLE	21201-030-WOL-1
N6 NOZZLE	21201-053-WOL-1

During 2R14, all 6 weld overlays will be examined to meet the initial inspection requirement. Weld overlay examination volumes that show no indication of crack growth or new cracking shall be placed into a population to be examined on a twenty-five percent sample (2 welds). In order to address the third ISI interval requirements, these two welds are scheduled for the 2R18 outage. SNC committed in letter NL-07-0803, dated April 13, 2007, to perform future ISI examinations in accordance with Q-4300 of Appendix Q to the 2004 Edition of Section XI with Addenda through 2005.

The Category is WOL and the Item is Q-4300 in ScheduleWorks.

**VOGTLE UNIT 2 THIRD INTERVAL ISI PLAN
AUGMENTED EXAMINATIONS**

ISI PLAN TABLES

ISI Plan Tables are generated by the industry standard ScheduleWorks software. It should be noted that the Scope/Method/Procedure field is for *information only*. This information may be changed during an outage by authorized IDDEAL software users at the site, but it will not be reflected in the ISI Plan until the plan is issued after the outage. When using these tables the user needs to understand the following symbols:

Scheduled	"s" To schedule a component, place the identifier "s" in the required period/outage.
Completed	"c" Upon exam completion for a scheduled component and by uploading the outage scope from IDDEAL back to ScheduleWorks, an "s" will be updated to completed "c".
Re-scheduled	"r" Once a component has been scheduled, and you wish to reschedule to another outage, replace the scheduled "s" with a rescheduled "r" and enter an "s" in the new outage schedule.
Expanded Scope	"e" To increase a work scope without taking code credit in the percentage calculations, enter an expanded "e".
Expanded Scope Completed	"E" Upon exam completion of an expanded scope and by either uploading the outage scope from IDDEAL or manually changing the letter to an upper case "E" the exam scope is completed.
Additional Scheduled	"a" After an initial expanded work scope has been identified and you wish to add an increased expanded work scope, enter an additional expanded scope "a".
Additional Completed	"A" Upon exam completion of an additional expanded scope and by either uploading the outage scope from IDDEAL or manually changing the letter to an upper case "A" the exam scope is completed.
Partial	"p" To track partially completed component examination requirements enter a partial "p".
Deferred	"d" Once a component has been scheduled, and you wish to defer the inspection to another Outage, or Period, replace the scheduled "s" with a deferred "d" and enter an "s" in the new Outage.
Limited	"l" To track limited component examinations or limited completions of requirements enter "l".
Multiple Scheduled	"b" For multiple scheduling of the same component in successive Outages or Periods within an Interval enter "b".
Multiple Completed	"B" Upon exam completion of a multiple scope in the same Interval and by either uploading the outage scope from IDDEAL or manually changing the letter to an upper case "B" the exam scope is completed. This multiple scheduling scope will not count as completed for code calculations.
Tickler	"t" To track exam scopes or use as reminder or identifier to confirm scheduling enter "t".
Successive Exams	"h" Successive examinations.
Successive Exams Completed	"H" Upon exam completion of a successive scope and by either uploading the outage scope from IDDEAL or manually changing the letter to an upper case "H" the exam scope is completed.

Southern Nuclear Operating Company
3rd Interval
VOGTLE-2 ISI PLAN, VERSION 3.0

Category, Item No., Class	Summary No./ComplID/System	Scope / Method / Procedure	Dwg/ISO No. Comp. Desc. Code Case		Period 1		Period 2			Period 3			
					2VR13	2VR14	2VR14A	2VR15	2VR16	2VR17	2VR18		
N-722	V2 21201-B6-001-I10-VT	ISI/VT/NMP-ES-024-202	ISI-21201-B6-001	ISI	c	b	-	-	-	b	b	-	-
			CHANNEL HEAD DRAIN TUBE (WCAP 12907)	AUG	-	-	-	-	-	-	-	-	-
				OWN	-	-	-	-	-	-	-	-	-
				PRE	-	-	-	-	-	-	-	-	-
B15.120	21201-B6-001-I10-VT	ISI/VT/NMP-ES-024-202	ISI-21201-B6-001	AUG	-	-	-	-	-	-	-	-	-
1	1201	ISI/VT/		OWN	-	-	-	-	-	-	-	-	-
				PRE	-	-	-	-	-	-	-	-	-
N-722	V2 21201-B6-002-I10-VT	ISI/VT/NMP-ES-024-202	ISI-21201-B6-002	ISI	c	b	-	-	-	b	b	-	-
			CHANNEL HEAD DRAIN TUBE (WCAP 12907)	AUG	-	-	-	-	-	-	-	-	-
				OWN	-	-	-	-	-	-	-	-	-
				PRE	-	-	-	-	-	-	-	-	-
B15.120	21201-B6-002-I10-VT	ISI/VT/NMP-ES-024-202	ISI-21201-B6-002	AUG	-	-	-	-	-	-	-	-	-
1	1201	ISI/VT/		OWN	-	-	-	-	-	-	-	-	-
				PRE	-	-	-	-	-	-	-	-	-
N-722	V2 21201-B6-003-I10-VT	ISI/VT/NMP-ES-024-202	ISI-21201-B6-003	ISI	c	b	-	-	-	b	b	-	-
			CHANNEL HEAD DRAIN TUBE (WCAP 12907)	AUG	-	-	-	-	-	-	-	-	-
				OWN	-	-	-	-	-	-	-	-	-
				PRE	-	-	-	-	-	-	-	-	-
B15.120	21201-B6-003-I10-VT	ISI/VT/NMP-ES-024-202	ISI-21201-B6-003	AUG	-	-	-	-	-	-	-	-	-
1	1201	ISI/VT/		OWN	-	-	-	-	-	-	-	-	-
				PRE	-	-	-	-	-	-	-	-	-
N-722	V2 21201-B6-004-I10-VT	ISI/VT/	ISI-21201-B6-004	ISI	c	b	-	-	-	b	b	-	-
			CHANNEL HEAD DRAIN TUBE (WCAP 12907)	AUG	-	-	-	-	-	-	-	-	-
				OWN	-	-	-	-	-	-	-	-	-
				PRE	-	-	-	-	-	-	-	-	-
B15.120	21201-B6-004-I10-VT	ISI/VT/	ISI-21201-B6-004	AUG	-	-	-	-	-	-	-	-	-
1	1201	ISI/VT/		OWN	-	-	-	-	-	-	-	-	-
				PRE	-	-	-	-	-	-	-	-	-
N-722	V2 21201-V6-001-BMI-BMV	ISI/VT/	ISI-21201-V6-001	ISI	c	b	-	-	-	b	b	-	-
			RPV BOTTOM HEAD	AUG	-	-	-	-	-	-	-	-	-
			INSTRUMENTATION BMV	OWN	-	-	-	-	-	-	-	-	-
				PRE	-	-	-	-	-	-	-	-	-
B15.80	21201-V6-001-BMI-BMV	ISI/VT/NMP-ES-024-208	ISI-21201-V6-001	AUG	-	-	-	-	-	-	-	-	-
1	1201	ISI/VT/NMP-ES-024-208		OWN	-	-	-	-	-	-	-	-	-
				PRE	-	-	-	-	-	-	-	-	-
N-722	V2 21201-V6-001-W33-BMV	ISI/VT/NMP-ES-024-202	ISI-21201-V6-001	ISI	c	b	-	-	-	b	-	-	-
			OUTLET NOZZLE N1 SAFE END BMV	AUG	-	-	-	-	-	-	-	-	-
				OWN	-	-	-	-	-	-	-	-	-
				PRE	-	-	-	-	-	-	-	-	-
B15.90	21201-V6-001-W33-BMV	ISI/VT/	ISI-21201-V6-001	AUG	-	-	-	-	-	-	-	-	-
1	1201	ISI/VT/NMP-ES-024-202		OWN	-	-	-	-	-	-	-	-	-
				PRE	-	-	-	-	-	-	-	-	-
N-722	V2 21201-V6-001-W36-BMV	ISI/VT/NMP-ES-024-202	ISI-21201-V6-001	ISI	c	b	-	-	-	b	-	-	-
			OUTLET NOZZLE N4 SAFE END BMV	AUG	-	-	-	-	-	-	-	-	-
				OWN	-	-	-	-	-	-	-	-	-
				PRE	-	-	-	-	-	-	-	-	-
B15.90	21201-V6-001-W36-BMV	ISI/VT/NMP-ES-024-202	ISI-21201-V6-001	AUG	-	-	-	-	-	-	-	-	-
1	1201	ISI/VT/		OWN	-	-	-	-	-	-	-	-	-
				PRE	-	-	-	-	-	-	-	-	-
N-722	V2 21201-V6-001-W37-BMV	ISI/VT/NMP-ES-024-202	ISI-21201-V6-001	ISI	c	b	-	-	-	b	-	-	-
			OUTLET NOZZLE N5 SAFE END BMV	AUG	-	-	-	-	-	-	-	-	-
				OWN	-	-	-	-	-	-	-	-	-
				PRE	-	-	-	-	-	-	-	-	-
B15.90	21201-V6-001-W37-BMV	ISI/VT/NMP-ES-024-202	ISI-21201-V6-001	AUG	-	-	-	-	-	-	-	-	-
1	1201	ISI/VT/		OWN	-	-	-	-	-	-	-	-	-
				PRE	-	-	-	-	-	-	-	-	-
N-722	V2 21201-V6-001-W40-BMV	ISI/VT/NMP-ES-024-202	ISI-21201-V6-001	ISI	c	b	-	-	-	b	-	-	-
			OUTLET NOZZLE N8 SAFE END BMV	AUG	-	-	-	-	-	-	-	-	-
				OWN	-	-	-	-	-	-	-	-	-
B15.90	21201-V6-001-W40-BMV	ISI/VT/NMP-ES-024-202	ISI-21201-V6-001	AUG	-	-	-	-	-	-	-	-	-
1	1201	ISI/VT/		OWN	-	-	-	-	-	-	-	-	-
				PRE	-	-	-	-	-	-	-	-	-

Southern Nuclear Operating Company

3rd Interval

VOGTLE-2 ISI PLAN, VERSION 3.0

Category, Item No., Class	Summary No./CompID/System	Scope / Method / Procedure ISI/VT/	Dwg/ISO No. Comp. Desc. Code Case		Period 1		Period 2		Period 3		
					2VR13	2VR14	2VR14A	2VR15	2VR16	2VR17	2VR18
N-722 B15.95 1	V2 21201-V6-001-W34-BMV 21201-V6-001-W34-BMV 1201	ISI/VT/NMP-ES-024-202	ISI-21201-V6-001 INLET NOZZLE N2 TO SAFE END BMV	PRE	-	-	-	-	-	-	-
				ISI	c	-	-	-	-	-	-
				AUG	-	-	-	-	-	-	-
				OWN	-	-	-	-	-	-	-
N-722 B15.95 1	V2 21201-V6-001-W35-BMV 21201-V6-001-W35-BMV 1201	AUG/VT/NMP-ES-024-202	ISI-21201-V6-001 INLET NOZZLE N3 TO SAFE END BMV	PRE	-	-	-	-	-	-	-
				ISI	c	-	-	-	-	-	-
				AUG	-	-	-	-	-	-	-
				OWN	-	-	-	-	-	-	-
N-722 B15.95 1	V2 21201-V6-001-W38-BMV 21201-V6-001-W38-BMV 1201	ISI/VT/NMP-ES-024-202	ISI-21201-V6-001 INLET NOZZLE N6 TO SAFE END BMV	PRE	-	-	-	-	-	-	-
				ISI	c	-	-	-	-	-	-
				AUG	-	-	-	-	-	-	-
				OWN	-	-	-	-	-	-	-
N-722 B15.95 1	V2 21201-V6-001-W39-BMV 21201-V6-001-W39-BMV 1201	ISI/VT/NMP-ES-024-202	ISI-21201-V6-001 INLET NOZZLE N7 TO SAFE END BMV	PRE	-	-	-	-	-	-	-
				ISI	c	-	-	-	-	-	-
				AUG	-	-	-	-	-	-	-
				OWN	-	-	-	-	-	-	-
				PRE	-	-	-	-	-	-	

Southern Nuclear Operating Company
3rd Interval
VOGTLE-2 ISI PLAN, VERSION 3.0

Category, Item No., Class	Summary No./ComplID/System	Scope / Method / Procedure	Dwg/ISO No. Comp. Desc. Code Case	Period 1		Period 2			Period 3	
				2VR13	2VR14	2VR14A	2VR15	2VR16	2VR17	2VR18
N-729 B4.10 BMV 1	V2 21201-V6-001-CRDM(BMV) 1201	ISI/VT/ VESSEL CLOSURE HEAD EXTERIOR	ISI	c	-	-	-	-	-	-
			AUG	-	-	-	-	b	-	-
			OWN	-	-	-	-	-	-	-
			PRE	-	-	-	-	-	-	-
N-729 B4.10 VT2 1	V2 21201-V6-CRDM(VT-2) 21201-V6-CRDM(VT-2) 1201	ISI/VT/NMP-ES-024-202 ISI/VT/ ISI/VT/ ISI/VT/	ISI	c	b	-	-	-	b	b
			AUG	-	-	-	-	b	-	-
			OWN	-	-	-	-	-	-	-
			PRE	-	-	-	-	-	-	-
N-729 B4.20 1	V2 21201-V6-CRDM(VOL) 21201-V6-CRDM(VOL) 1201	ISI/UT/ CRDM NOZZLE AND BASE MATERIAL	ISI	-	-	-	-	s	-	-
			AUG	-	-	-	-	-	-	
			OWN	-	-	-	-	-	-	
			PRE	-	-	-	-	-	-	

Southern Nuclear Operating Company
3rd Interval
VOGTLE-2 ISI PLAN, VERSION 3.0

Category, Item No., Class	Summary No./ComplID/System	Scope / Method / Procedure	Dwg/ISO No. Comp. Desc. Code Case		Period 1		Period 2			Period 3	
					2VR13	2VR14	2VR14A	2VR15	2VR16	2VR17	2VR18
OE	V2 21205-003-46-OE-UT	ISI/UT/NMP-ES-024-501	ISI-21205-003	ISI	c	-	-	-	-	-	-
MRP-192	21205-003-46-OE-UT		14" PIPE	AUG	-	-	-	-	-	-	-
2	1205			OWN	-	-	-	-	-	-	-
				PRE	-	-	-	-	-	-	-
OE	V2 21205-004-33-OE-UT	ISI/UT/NMP-ES-024-501	ISI-21205-004	ISI	c	-	-	-	-	-	-
MRP-192	21205-004-33-OE-UT		14" PIPE	AUG	-	-	-	-	-	-	-
2	1205			OWN	-	-	-	-	-	-	-
				PRE	-	-	-	-	-	-	-

Southern Nuclear Operating Company
3rd Interval
VOGTLE-2 ISI PLAN, VERSION 3.0

Category, Item No., Class	Summary No./ComplD/System	Scope / Method / Procedure	Dwg/ISO No. Comp. Desc. Code Case		Period 1		Period 2		Period 3		
					2VR13	2VR14	2VR14A	2VR15	2VR16	2VR17	2VR18
C-F-1(R)	V2 21205-003-46	ISI/UT/NMP-ES-024-501	ISI-21205-003	ISI	c	-	-	-	-	-	-
C5.11	21205-003-46	ISI/UT/NMP-ES-024-501	14" PIPE TO ELBOW	AUG	-	-	-	-	-	-	-
2	1205			OWN	-	-	-	-	-	-	-
				PRE	-	-	-	-	-	-	-
C-F-1(R)	V2 21205-003-47	ISI/UT/NMP-ES-024-501	ISI-21205-003	ISI	c	-	-	-	-	-	-
C5.11	21205-003-47	ISI/UT/NMP-ES-024-501	14" ELBOW TO PIPE	AUG	-	-	-	-	-	-	-
2	1205			OWN	-	-	-	-	-	-	-
				PRE	-	-	-	-	-	-	-
C-F-1(R)	V2 21205-003-48	ISI/UT/NMP-ES-024-501	ISI-21205-003	ISI	c	-	-	-	-	-	-
C5.11	21205-003-48	ISI/UT/NMP-ES-024-501	14" PIPE TO ELBOW	AUG	-	-	-	-	-	-	-
2	1205			OWN	-	-	-	-	-	-	-
				PRE	-	-	-	-	-	-	-
C-F-1(R)	V2 21205-004-33	ISI/UT/NMP-ES-024-501	ISI-21205-004	ISI	c	-	-	-	-	-	-
C5.11	21205-004-33	ISI/UT/NMP-ES-024-501	14" PIPE TO ELBOW	AUG	-	-	-	-	-	-	-
2	1205			OWN	-	-	-	-	-	-	-
				PRE	-	-	-	-	-	-	-
C-F-1(R)	V2 21205-004-34	ISI/UT/NMP-ES-024-501	ISI-21205-004	ISI	c	-	-	-	-	-	-
C5.11	21205-004-34	ISI/UT/NMP-ES-024-501	14" ELBOW TO PIPE	AUG	-	-	-	-	-	-	-
2	1205			OWN	-	-	-	-	-	-	-
				PRE	-	-	-	-	-	-	-
C-F-1(R)	V2 21205-004-35	ISI/UT/NMP-ES-024-501	ISI-21205-004	ISI	c	-	-	-	-	-	-
C5.11	21205-004-35	ISI/UT/NMP-ES-024-501	14" PIPE TO ELBOW	AUG	-	-	-	-	-	-	-
2	1205			OWN	-	-	-	-	-	-	-
				PRE	-	-	-	-	-	-	-

Southern Nuclear Operating Company
3rd Interval
VOGTLE-2 ISI PLAN, VERSION 3.0

Category, Item No., Class	Summary No./CompID/System	Scope / Method / Procedure	Dwg/ISO No. Comp. Desc. Code Case		Period 1		Period 2			Period 3	
					2VR13	2VR14	2VR14A	2VR15	2VR16	2VR17	2VR18
SG PP VT 1	V2 21201-B6-001-I04 21201-B6-001-I04 1201	ISI/VT/NMP-ES-024-202	ISI-21201-01 PARTION PLATE	ISI AUG OWN PRE	-	-	-	-	s	-	-
SG PP VT 1	V2 21201-B6-002-I04 21201-B6-002-I04 1201	ISI/VT/	ISI-21201-01 PARTION PLATE	ISI AUG OWN PRE	-	-	-	-	-	s	-
SG PP VT 1	V2 21201-B6-003-I04 21201-B6-003-I04 1201	ISI/VT/NMP-ES-024-202	ISI-21201-01 PARTION PLATE	ISI AUG OWN PRE	-	-	-	-	s	-	-
SG PP VT 1	V2 21201-B6-004-I04 21201-B6-004-I04 1201	ISI/VT/	ISI-21201-01 PARTION PLATE	ISI AUG OWN PRE	-	-	-	-	-	s	-

Southern Nuclear Operating Company
3rd Interval
VOGTLE-2 ISI PLAN, VERSION 3.0

Category, Item No., Class	Summary No./CompID/System	Scope / Method / Procedure	Dwg/ISO No. Comp. Desc. Code Case		Period 1		Period 2		Period 3	
					2VR13	2VR14	2VR14A	2VR15	2VR16	2VR17
AUG	V2 21201-P6-001-FLY	ISI/UT/NMP-ES-024-517	ISI-21201-P6-001	ISI	-	s	-	-	-	-
TS 5.5.7	21201-P6-001-FLY	ISI/PT/NMP-ES-024-301	RCP FLY WHEEL (TS 5.5.7)	AUG	-	-	-	-	-	-
1	1201			OWN	-	-	-	-	-	-
				PRE	-	-	-	-	-	-
AUG	V2 21201-P6-002-FLY	ISI/PT/	ISI-21201-P6-002	ISI	-	-	-	s	-	-
TS 5.5.7	21201-P6-002-FLY	ISI/UT/	RCP FLY WHEEL (TS 5.5.7)	AUG	-	-	-	-	-	-
1	1201			OWN	-	-	-	-	-	-
				PRE	-	-	-	-	-	-
AUG	V2 21201-P6-003-FLY	ISI/PT/NMP-ES-024-301	ISI-21201-P6-003	ISI	-	s	-	-	-	-
TS 5.5.7	21201-P6-003-FLY	ISI/UT/NMP-ES-024-517	RCP FLY WHEEL (TS 5.5.7)	AUG	-	-	-	-	-	-
1	1201			OWN	-	-	-	-	-	-
				PRE	-	-	-	-	-	-
AUG	V2 21201-P6-004-FLY	ISI/PT/	ISI-21201-P6-004	ISI	-	-	-	-	s	-
TS 5.5.7	21201-P6-004-FLY	ISI/UT/	RCP FLY WHEEL (TS 5.5.7)	AUG	-	-	-	-	-	-
1	1201			OWN	-	-	-	-	-	-
				PRE	-	-	-	-	-	-

Southern Nuclear Operating Company

3rd Interval

VOGTLE-2 ISI PLAN, VERSION 3.0

Category, Item No., Class	Summary No./ComplD/System	Scope / Method / Procedure	Dwg/ISO No. Comp. Desc. Code Case		Period 1		Period 2			Period 3	
					2VR13	2VR14	2VR14A	2VR15	2VR16	2VR17	2VR18
HEL B	V2 21305-058-1-HEL B	AUG/UT/	ISI-21305-058	ISI	-	-	-	-	-	-	-
FW-Butt 2	21305-058-1-HEL B 1305		FORGING TO 16" PIPE (TS 5.5.16)	AUG OWN PRE	-	-	-	-	s	-	-
HEL B	V2 21305-058-2-HEL B	AUG/UT/	ISI-21305-058	ISI	-	-	-	-	-	-	-
FW-Butt 2	21305-058-2-HEL B 1305		16" PIPE TO 6" BRANCH CONNECTION (TS 5.5.16)	AUG OWN PRE	-	-	-	-	s	-	-
HEL B	V2 21305-058-4-HEL B	AUG/UT/	ISI-21305-058	ISI	-	-	-	-	-	-	-
FW-Butt 2	21305-058-4-HEL B 1305		16" PIPE TO VALVE (TS 5.5.16)	AUG OWN PRE	-	-	-	-	s	-	-
HEL B	V2 21305-058-5-HEL B	AUG/UT/	ISI-21305-058	ISI	-	-	-	-	-	-	-
FW-Butt 2	21305-058-5-HEL B 1305		16" VALVE TO PIPE (TS 5.5.16)	AUG OWN PRE	-	-	-	-	s	-	-
HEL B	V2 21305-058-6-HEL B	AUG/UT/	ISI-21305-058	ISI	-	-	-	-	-	-	-
FW-Butt 2	21305-058-6-HEL B 1305		16" PIPE TO VALVE (TS 5.5.16)	AUG OWN PRE	-	-	-	-	s	-	-
HEL B	V2 21305-058-7-HEL B	AUG/UT/	ISI-21305-058	ISI	-	-	-	-	-	-	-
FW-Butt 2	21305-058-7-HEL B 1305		16" VALVE TO PIPE (TS 5.5.16)	AUG OWN PRE	-	-	-	-	s	-	-
HEL B	V2 21305-058-8-HEL B	AUG/UT/	ISI-21305-058	ISI	-	-	-	-	-	-	-
FW-Butt 2	21305-058-8-HEL B 1305		16" PIPE TO PENETRATION (TS 5.5.16)	AUG OWN PRE	-	-	-	-	s	-	-
HEL B	V2 21305-060-1-HEL B	AUG/UT/	ISI-21305-060	ISI	-	-	-	-	-	-	-
FW-Butt 2	21305-060-1-HEL B 1305		FORGING TO 16" PIPE (TS 5.5.16)	AUG OWN PRE	-	-	-	-	s	-	-
HEL B	V2 21305-060-2-HEL B	AUG/UT/NMP-ES-024-502	ISI-21305-060	ISI	-	-	-	-	-	-	-
FW-Butt 2	21305-060-2-HEL B 1305		16" PIPE TO 6" BRANCH CONNECTION (TS 5.5.16)	AUG OWN PRE	-	s	-	-	-	-	-
HEL B	V2 21305-060-4-HEL B	AUG/UT/NMP-ES-024-502	ISI-21305-060	ISI	-	-	-	-	-	-	-
FW-Butt	21305-060-4-HEL B		16" PIPE TO VALVE (TS 5.5.16)	AUG	-	s	-	-	-	-	-

Southern Nuclear Operating Company
3rd Interval
VOGTLE-2 ISI PLAN, VERSION 3.0

Category, Item No., Class	Summary No./CompID/System	Scope / Method / Procedure	Dwg/ISO No. Comp. Desc. Code Case		Period 1		Period 2		Period 3	
					2VR13	2VR14	2VR14A	2VR15	2VR16	2VR17
	1305			OWN	-	-	-	-	-	-
	1305			PRE	-	-	-	-	-	-
HEL B	V2 21305-060-5-HEL B	AUG/UT/	ISI-21305-060	ISI	-	-	-	-	-	-
FW-Butt	21305-060-5-HEL B		16" VALVE TO PIPE (TS 5.5.16)	AUG	-	-	-	s	-	-
2	1305			OWN	-	-	-	-	-	-
	1305			PRE	-	-	-	-	-	-
HEL B	V2 21305-060-6-HEL B	AUG/UT/	ISI-21305-060	ISI	-	-	-	-	-	-
FW-Butt	21305-060-6-HEL B		16" PIPE TO VALVE (TS 5.5.16)	AUG	-	-	-	s	-	-
2	1305			OWN	-	-	-	-	-	-
	1305			PRE	-	-	-	-	-	-
HEL B	V2 21305-060-7-HEL B	AUG/UT/NMP-ES-024-502	ISI-21305-060	ISI	-	-	-	-	-	-
FW-Butt	21305-060-7-HEL B		16" VALVE TO PIPE (TS 5.5.16)	AUG	-	s	-	-	-	-
2	1305			OWN	-	-	-	-	-	-
	1305			PRE	-	-	-	-	-	-
HEL B	V2 21305-060-8-HEL B	AUG/UT/NMP-ES-024-502	ISI-21305-060	ISI	-	-	-	-	-	-
FW-Butt	21305-060-8-HEL B		16" PIPE TO PENETRATION (TS 5.5.16)	AUG	-	s	-	-	-	-
2	1305			OWN	-	-	-	-	-	-
	1305			PRE	-	-	-	-	-	-
HEL B	V2 21305-062-10-HEL B	AUG/UT/	ISI-21305-062	ISI	-	-	-	-	-	-
FW-Butt	21305-062-10-HEL B		16" VALVE TO PIPE (TS 5.5.16)	AUG	-	-	-	-	s	-
2	1305			OWN	-	-	-	-	-	-
	1305			PRE	-	-	-	-	-	-
HEL B	V2 21305-062-11-HEL B	AUG/UT/	ISI-21305-062	ISI	-	-	-	-	-	-
FW-Butt	21305-062-11-HEL B		16" PIPE TO PENETRATION (TS 5.5.16)	AUG	-	-	-	-	s	-
2	1305			OWN	-	-	-	-	-	-
	1305			PRE	-	-	-	-	-	-
HEL B	V2 21305-062-1-HEL B	AUG/UT/	ISI-21305-062	ISI	-	-	-	-	-	-
FW-Butt	21305-062-1-HEL B		FORGING TO 16" PIPE (TS 5.5.16)	AUG	-	-	-	-	s	-
2	1305			OWN	-	-	-	-	-	-
	1305			PRE	-	-	-	-	-	-
HEL B	V2 21305-062-2-HEL B	AUG/UT/	ISI-21305-062	ISI	-	-	-	-	-	-
FW-Butt	21305-062-2-HEL B		16" PIPE TO PIPE (TS 5.5.16)	AUG	-	-	-	-	s	-
2	1305			OWN	-	-	-	-	-	-
	1305			PRE	-	-	-	-	-	-
HEL B	V2 21305-062-3-HEL B	AUG/UT/	ISI-21305-062	ISI	-	-	-	-	-	-
FW-Butt	21305-062-3-HEL B		16" PIPE TO PIPE (TS 5.5.16)	AUG	-	-	-	-	s	-
2	1305			OWN	-	-	-	-	-	-
	1305			PRE	-	-	-	-	-	-
HEL B	V2 21305-062-4-HEL B	AUG/UT/	ISI-21305-062	ISI	-	-	-	-	-	-

Southern Nuclear Operating Company

3rd Interval

VOGTLE-2 ISI PLAN, VERSION 3.0

Category, Item No., Class	Summary No./CompID/System	Scope / Method / Procedure	Dwg/ISO No. Comp. Desc. Code Case		Period 1		Period 2		Period 3				
					2VR13	2VR14	2VR14A	2VR15	2VR16	2VR17	2VR18		
FW-Butt 2	21305-062-4-HEL 1305		16" PIPE TO 6" BRANCH CONNECTION (TS 5.5.16)	AUG OWN PRE	-	-	-	-	-	-	s	-	-
HELB FW-Butt 2	V2 21305-062-6-HEL 21305-062-6-HEL 1305	AUG/UT/	ISI-21305-062 16" PIPE TO VALVE (TS 5.5.16)	ISI AUG OWN PRE	-	-	-	-	-	-	-	s	-
HELB FW-Butt 2	V2 21305-062-7-HEL 21305-062-7-HEL 1305	AUG/UT/	ISI-21305-062 16" VALVE TO PIPE (TS 5.5.16)	ISI AUG OWN PRE	-	-	-	-	-	-	-	s	-
HELB FW-Butt 2	V2 21305-062-9-HEL 21305-062-9-HEL 1305	AUG/UT/	ISI-21305-062 16" PIPE TO VALVE (TS 5.5.16)	ISI AUG OWN PRE	-	-	-	-	-	-	-	s	-
HELB FW-Butt 2	V2 21305-064-1 A-HEL 21305-064-1 A-HEL 1305	AUG/UT/	ISI-21305-064 16" PIPE TO PIPE (TS 5.5.16)	ISI AUG OWN PRE	-	-	-	-	-	-	-	s	-
HELB FW-Butt 2	V2 21305-064-1-HEL 21305-064-1-HEL 1305	AUG/UT/	ISI-21305-064 FORGING TO 16" PIPE (TS 5.5.16)	ISI AUG OWN PRE	-	-	-	-	-	-	-	s	-
HELB FW-Butt 2	V2 21305-064-2-HEL 21305-064-2-HEL 1305	AUG/UT/	ISI-21305-064 16" PIPE TO 6" BRANCH CONNECTION (TS 5.5.16)	ISI AUG OWN PRE	-	-	-	-	-	-	-	s	-
HELB FW-Butt 2	V2 21305-064-4-HEL 21305-064-4-HEL 1305	AUG/UT/	ISI-21305-064 16" PIPE TO VALVE (TS 5.5.16)	ISI AUG OWN PRE	-	-	-	-	-	-	-	s	-
HELB FW-Butt 2	V2 21305-064-5-HEL 21305-064-5-HEL 1305	AUG/UT/	ISI-21305-064 16" VALVE TO PIPE (TS 5.5.16)	ISI AUG OWN PRE	-	-	-	-	-	-	-	s	-
HELB FW-Butt 2	V2 21305-064-7-HEL 21305-064-7-HEL 1305	AUG/UT/	ISI-21305-064 16" PIPE TO VALVE (TS 5.5.16)	ISI AUG OWN	-	-	-	-	-	-	-	s	-

Southern Nuclear Operating Company
3rd Interval
VOGTLE-2 ISI PLAN, VERSION 3.0

Category, Item No., Class	Summary No./CompID/System	Scope / Method / Procedure	Dwg/ISO No. Comp. Desc. Code Case		Period 1		Period 2		Period 3	
					2VR13	2VR14	2VR14A	2VR15	2VR16	2VR17
				PRE	-	-	-	-	-	-
HELB	V2 21305-064-8-HELB	AUG/UT/	ISI-21305-064	ISI	-	-	-	-	-	-
FW-Butt	21305-064-8-HELB		16" VALVE TO PIPE (TS 5.5.16)	AUG	-	-	-	-	-	s
2	1305			OWN	-	-	-	-	-	-
				PRE	-	-	-	-	-	-
HELB	V2 21305-064-9-HELB	AUG/UT/	ISI-21305-064	ISI	-	-	-	-	-	-
FW-Butt	21305-064-9-HELB		16" PIPE TO PENETRATION (TS 5.5.16)	AUG	-	-	-	-	-	s
2	1305			OWN	-	-	-	-	-	-
				PRE	-	-	-	-	-	-
HELB	V2 21301-001-11-HELB	AUG/UT/	ISI-21301-001	ISI	-	-	-	-	-	-
MS-Butt	21301-001-11-HELB		29 1/2" PIPE TO VALVE (TS 5.5.16)	AUG	-	-	-	s	-	-
2	1301			OWN	-	-	-	-	-	-
				PRE	-	-	-	-	-	-
HELB	V2 21301-001-12-HELB	AUG/UT/NMP-ES-024-502	ISI-21301-001	ISI	-	-	-	-	-	-
MS-Butt	21301-001-12-HELB		VALVE TO 29 1/2" PIPE (TS 5.5.16)	AUG	-	s	-	-	-	-
2	1301			OWN	-	-	-	-	-	-
				PRE	-	-	-	-	-	-
HELB	V2 21301-001-14-HELB	AUG/UT/NMP-ES-024-502	ISI-21301-001	ISI	-	-	-	-	-	-
MS-Butt	21301-001-14-HELB		29 1/2" PIPE TO VALVE (TS 5.5.16)	AUG	-	s	-	-	-	-
2	1301			OWN	-	-	-	-	-	-
				PRE	-	-	-	-	-	-
HELB	V2 21301-001-15-HELB	AUG/UT/	ISI-21301-001	ISI	-	-	-	-	-	-
MS-Butt	21301-001-15-HELB		VALVE TO 28" PIPE (TS 5.5.16)	AUG	-	-	-	s	-	-
2	1301			OWN	-	-	-	-	-	-
				PRE	-	-	-	-	-	-
HELB	V2 21301-001-16-HELB	AUG/UT/	ISI-21301-001	ISI	-	-	-	-	-	-
MS-Butt	21301-001-16-HELB		28" PIPE TO PIPE FORGING (TS 5.5.16)	AUG	-	-	-	s	-	-
2	1301			OWN	-	-	-	-	-	-
				PRE	-	-	-	-	-	-
HELB	V2 21301-001-1-HELB	AUG/UT/NMP-ES-024-502	ISI-21301-001	ISI	-	-	-	-	-	-
MS-Butt	21301-001-1-HELB		28" PENETRATION TO PIPE (TS 5.5.16)	AUG	-	s	-	-	-	-
2	1301			OWN	-	-	-	-	-	-
				PRE	-	-	-	-	-	-
HELB	V2 21301-001-2-HELB	AUG/UT/	ISI-21301-001	ISI	-	-	-	-	-	-
MS-Butt	21301-001-2-HELB		28" PIPE TO PIPE (TS 5.5.16)	AUG	-	-	-	s	-	-
2	1301			OWN	-	-	-	-	-	-
				PRE	-	-	-	-	-	-
HELB	V2 21301-001-3-HELB	AUG/UT/	ISI-21301-001	ISI	-	-	-	-	-	-
MS-Butt	21301-001-3-HELB		28" PIPE TO PIPE (TS 5.5.16)	AUG	-	-	-	s	-	-
2	1301			OWN	-	-	-	-	-	-

Southern Nuclear Operating Company
3rd Interval
VOGTLE-2 ISI PLAN, VERSION 3.0

Category, Item No., Class	Summary No./ComplID/System	Scope / Method / Procedure	Dwg/ISO No. Comp. Desc. Code Case		Period 1		Period 2			Period 3	
					2VR13	2VR14	2VR14A	2VR15	2VR16	2VR17	2VR18
HEL B	V2 21301-001-4-HEL B	AUG/UT/NMP-ES-024-502	ISI-21301-001	PRE	-	-	-	-	-	-	-
MS-Butt 2	21301-001-4-HEL B 1301		28" PIPE TO 29 1/2" PIPE (TS 5.5.16)	ISI AUG OWN PRE	-	s	-	-	-	-	-
HEL B	V2 21301-002-10-HEL B	AUG/UT/	ISI-21301-002	ISI	-	-	-	-	-	-	-
MS-Butt 2	21301-002-10-HEL B 1301		29 1/2" PIPE TO VALVE (TS 5.5.16)	AUG OWN PRE	-	-	-	-	-	s	-
HEL B	V2 21301-002-11-HEL B	AUG/UT/	ISI-21301-002	ISI	-	-	-	-	-	-	-
MS-Butt 2	21301-002-11-HEL B 1301		VALVE TO 29 1/2" PIPE (TS 5.5.16)	AUG OWN PRE	-	-	-	-	-	s	-
HEL B	V2 21301-002-13-HEL B	AUG/UT/	ISI-21301-002	ISI	-	-	-	-	-	-	-
MS-Butt 2	21301-002-13-HEL B 1301		29 1/2" PIPE TO VALVE (TS 5.5.16)	AUG OWN PRE	-	-	-	-	-	s	-
HEL B	V2 21301-002-14-HEL B	AUG/UT/	ISI-21301-002	ISI	-	-	-	-	-	-	-
MS-Butt 2	21301-002-14-HEL B 1301		VALVE TO 28" PIPE (TS 5.5.16)	AUG OWN PRE	-	-	-	-	-	s	-
HEL B	V2 21301-002-15-HEL B	AUG/UT/	ISI-21301-002	ISI	-	-	-	-	-	-	-
MS-Butt 2	21301-002-15-HEL B 1301		28" PIPE TO PIPE FORGING (TS 5.5.16)	AUG OWN PRE	-	-	-	-	-	s	-
HEL B	V2 21301-002-1-HEL B	AUG/UT/	ISI-21301-002	ISI	-	-	-	-	-	-	-
MS-Butt 2	21301-002-1-HEL B 1301		PENETRATION TO 28" PIPE (TS 5.5.16)	AUG OWN PRE	-	-	-	-	-	s	-
HEL B	V2 21301-002-2-HEL B	AUG/UT/	ISI-21301-002	ISI	-	-	-	-	-	-	-
MS-Butt 2	21301-002-2-HEL B 1301		28" PIPE TO PIPE (TS 5.5.16)	AUG OWN PRE	-	-	-	-	-	s	-
HEL B	V2 21301-002-3-HEL B	AUG/UT/	ISI-21301-002	ISI	-	-	-	-	-	-	-
MS-Butt 2	21301-002-3-HEL B 1301		28" PIPE TO 29 1/2" PIPE (TS 5.5.16)	AUG OWN PRE	-	-	-	-	-	s	-
HEL B	V2 21301-003-10-HEL B	AUG/UT/	ISI-21301-003	ISI	-	-	-	-	-	-	-
MS-Butt 2	21301-003-10-HEL B 1301		29 1/2" PIPE TO VALVE (TS 5.5.16)	AUG OWN	-	-	-	-	-	s	-

Southern Nuclear Operating Company
3rd Interval
VOGTLE-2 ISI PLAN, VERSION 3.0

Category, Item No., Class	Summary No./CompID/System	Scope / Method / Procedure	Dwg/ISO No. Comp. Desc. Code Case	PRE ISI AUG OWN PRE	Period 1		Period 2			Period 3	
					2VR13	2VR14	2VR14A	2VR15	2VR16	2VR17	2VR18
HELB MS-Butt 2	V2 21301-003-11-HELB 21301-003-11-HELB 1301	AUG/UT/	ISI-21301-003 VALVE TO 29 1/2" PIPE (TS 5.5.16)	ISI AUG OWN PRE	-	-	-	-	-	-	-
HELB MS-Butt 2	V2 21301-003-13-HELB 21301-003-13-HELB 1301	AUG/UT/	ISI-21301-003 29 1/2" PIPE TO VALVE (TS 5.5.16)	ISI AUG OWN PRE	-	-	-	-	-	-	s
HELB MS-Butt 2	V2 21301-003-14-HELB 21301-003-14-HELB 1301	AUG/UT/	ISI-21301-003 VALVE TO 28" PIPE (TS 5.5.16)	ISI AUG OWN PRE	-	-	-	-	-	-	s
HELB MS-Butt 2	V2 21301-003-15-HELB 21301-003-15-HELB 1301	AUG/UT/	ISI-21301-003 28" PIPE TO PIPE FORGING (TS 5.5.16)	ISI AUG OWN PRE	-	-	-	-	-	-	s
HELB MS-Butt 2	V2 21301-003-1-HELB 21301-003-1-HELB 1301	AUG/UT/	ISI-21301-003 PENETRATION TO 28" PIPE (TS 5.5.16)	ISI AUG OWN PRE	-	-	-	-	-	-	s
HELB MS-Butt 2	V2 21301-003-2-HELB 21301-003-2-HELB 1301	AUG/UT/	ISI-21301-003 28" PIPE TO PIPE (TS 5.5.16)	ISI AUG OWN PRE	-	-	-	-	-	-	s
HELB MS-Butt 2	V2 21301-003-3-HELB 21301-003-3-HELB 1301	AUG/UT/	ISI-21301-003 28" PIPE TO 29 1/2" PIPE (TS 5.5.16)	ISI AUG OWN PRE	-	-	-	-	-	-	s
HELB MS-Butt 2	V2 21301-004-10-HELB 21301-004-10-HELB 1301	AUG/UT/	ISI-21301-004 29 1/2" PIPE TO VALVE (TS 5.5.16)	ISI AUG OWN PRE	-	-	-	-	s	-	-
HELB MS-Butt 2	V2 21301-004-11-HELB 21301-004-11-HELB 1301	AUG/UT/	ISI-21301-004 VALVE TO 29 1/2" PIPE (TS 5.5.16)	ISI AUG OWN PRE	-	-	-	-	s	-	-
HELB MS-Butt 2	V2 21301-004-13-HELB 21301-004-13-HELB 1301	AUG/UT/	ISI-21301-004 29 1/2" PIPE TO VALVE (TS 5.5.16)	ISI AUG OWN	-	-	-	-	s	-	-

Southern Nuclear Operating Company

3rd Interval

VOGTLE-2 ISI PLAN, VERSION 3.0

Category, Item No., Class	Summary No./CompID/System	Scope / Method / Procedure	Dwg/ISO No. Comp. Desc. Code Case	PRE	Period 1		Period 2			Period 3	
					2VR13	2VR14	2VR14A	2VR15	2VR16	2VR17	2VR18
HELB	V2 21301-004-14-HELB	AUG/UT/	ISI-21301-004	ISI	-	-	-	-	-	-	-
MS-Butt	21301-004-14-HELB		VALVE TO 28" PIPE (TS 5.5.16)	AUG	-	-	-	-	s	-	-
2	1301			OWN	-	-	-	-	-	-	-
				PRE	-	-	-	-	-	-	-
HELB	V2 21301-004-15-HELB	AUG/UT/	ISI-21301-004	ISI	-	-	-	-	-	-	-
MS-Butt	21301-004-15-HELB		28" PIPE TO PIPE FORGING (TS 5.5.16)	AUG	-	-	-	-	s	-	-
2	1301			OWN	-	-	-	-	-	-	-
				PRE	-	-	-	-	-	-	-
HELB	V2 21301-004-1-HELB	AUG/UT/	ISI-21301-004	ISI	-	-	-	-	-	-	-
MS-Butt	21301-004-1-HELB		PENETRATION TO 28" PIPE (TS 5.5.16)	AUG	-	-	-	-	s	-	-
2	1301			OWN	-	-	-	-	-	-	-
				PRE	-	-	-	-	-	-	-
HELB	V2 21301-004-2-HELB	AUG/UT/	ISI-21301-004	ISI	-	-	-	-	-	-	-
MS-Butt	21301-004-2-HELB		28" PIPE TO PIPE (TS 5.5.16)	AUG	-	-	-	-	s	-	-
2	1301			OWN	-	-	-	-	-	-	-
				PRE	-	-	-	-	-	-	-
HELB	V2 21301-004-3-HELB	AUG/UT/	ISI-21301-004	ISI	-	-	-	-	-	-	-
MS-Butt	21301-004-3-HELB		28" PIPE TO 29 1/2" PIPE (TS 5.5.16)	AUG	-	-	-	-	s	-	-
2	1301			OWN	-	-	-	-	-	-	-
				PRE	-	-	-	-	-	-	-

Southern Nuclear Operating Company
3rd Interval
VOGTLE-2 ISI PLAN, VERSION 3.0

Category, Item No., Class	Summary No./ComplD/System	Scope / Method / Procedure	Dwg/ISO No. Comp. Desc. Code Case		Period 1		Period 2			Period 3			
					2VR13	2VR14	2VR14A	2VR15	2VR16	2VR17	2VR18		
WOL Q-4300 1	V2 21201-030-WOL-1	ISI/UT/NMP-ES-024-509	ISI-21201-030 N-5 PRESSURIZER NOZZLE OVERLAY	ISI	-	s	-	-	-	-	-	-	
	21201-030-WOL-1			AUG	-	-	-	-	-	-	-	-	-
	1201			OWN	-	-	-	-	-	-	-	-	-
				PRE	-	-	-	-	-	-	-	-	-
WOL Q-4300 1	V2 21201-053-WOL-1	ISI/UT/NMP-ES-024-509	ISI-21201-053 N-6 PRESSURIZER OVERLAY	ISI	-	s	-	-	-	-	-	-	
	21201-053-WOL-1			AUG	-	-	-	-	-	-	-	-	-
	1201			OWN	-	-	-	-	-	-	-	-	-
				PRE	-	-	-	-	-	-	-	-	-
WOL Q-4300 1	V2 21201-056-WOL-1	ISI/UT/NMP-ES-024-509	ISI-21201-056 N-3 PRESSURIZER NOZZLE OVERLAY	ISI	-	s	-	-	-	-	-	-	
	21201-056-WOL-1			AUG	-	-	-	-	-	-	-	-	-
	1201			OWN	-	-	-	-	-	-	-	-	-
				PRE	-	-	-	-	-	-	-	-	-
WOL Q-4300 1	V2 21201-057-WOL-1	ISI/UT/NMP-ES-024-509	ISI-21201-057 N-2 PRESSURIZER NOZZLE OVERLAY	ISI	-	s	-	-	-	-	-	-	
	21201-057-WOL-1			AUG	-	-	-	-	-	-	-	-	-
	1201			OWN	-	-	-	-	-	-	-	-	-
				PRE	-	-	-	-	-	-	-	-	-
WOL Q-4300 1	V2 21201-058-WOL-1	ISI/UT/NMP-ES-024-509	ISI-21201-058 N-1 PRESSURIZER NOZZLE OVERLAY	ISI	-	s	-	-	-	-	-	-	
	21201-058-WOL-1			AUG	-	-	-	-	-	-	-	-	-
	1201			OWN	-	-	-	-	-	-	-	-	-
				PRE	-	-	-	-	-	-	-	-	-
WOL Q-4300 1	V2 21201-059-WOL-1	ISI/UT/NMP-ES-024-509	ISI-21201-056 N-4 PRESSURIZER NOZZLE OVERLAY	ISI	-	s	-	-	-	-	-	-	
	21201-059-WOL-1			AUG	-	-	-	-	-	-	-	-	-
	1201			OWN	-	-	-	-	-	-	-	-	-
				PRE	-	-	-	-	-	-	-	-	-