



U.S. NRC
UNITED STATES NUCLEAR REGULATORY COMMISSION

Protecting People and the Environment



Sandia
National
Laboratories

EPRI

DESIREE-FIRE

Direct Current Electrical Shorting In Response to Exposure-FIRE

2009 NEI Fire Protection Information Forum

Savannah, Georgia

Gabriel Taylor
NRC/RES

Harry Barrett
NRC/NRR

Dan Funk
Edan Engineering



**Office of Nuclear
Regulatory Research**





U.S.NRC
UNITED STATES NUCLEAR REGULATORY COMMISSION

Protecting People and the Environment

Project Overview

Gabe Taylor

Fire Protection Engineer

NRC/RES



**Office of Nuclear
Regulatory Research**



*Fire Research
Branch* 



U.S.NRC
UNITED STATES NUCLEAR REGULATORY COMMISSION

Protecting People and the Environment

DESIREE-FIRE

- Experimental testing program to evaluate direct current (dc) circuit response to fire exposure.
- Cooperative research project with EPRI
- Sandia National Laboratories is conducting the testing



Need for Testing

- Lack of data and uncertainties extrapolating alternating current (ac) results to dc circuits
- Numerous safety related systems commonly powered with dc
- Duke testing in 2006 indicated that dc circuits may react differently than ac circuits to fire-induced failures



U.S.NRC
UNITED STATES NUCLEAR REGULATORY COMMISSION

Protecting People and the Environment

Public Comment / Peer Review

- Project plan developed in September 2008
- 30 day public comment period
- Extensive peer review comment period (2 months)
- Most of the review related to dc electrical circuit instrumentation and representation of actual NPP applications



Testing Schedule

- Small-Scale
 - July to September 2009
- Intermediate-Scale
 - September to November 2009
- Draft Report
 - Early 2010

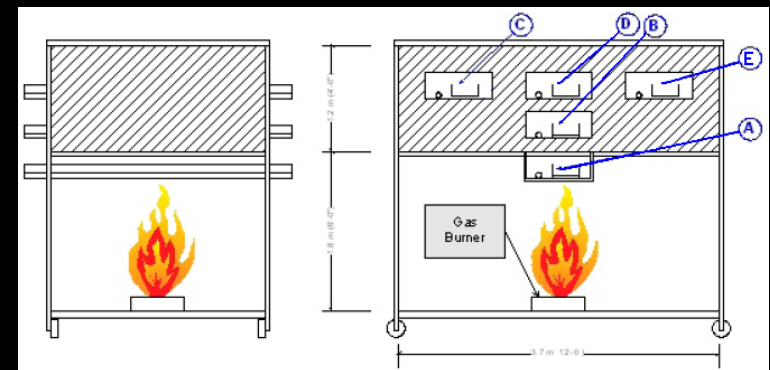
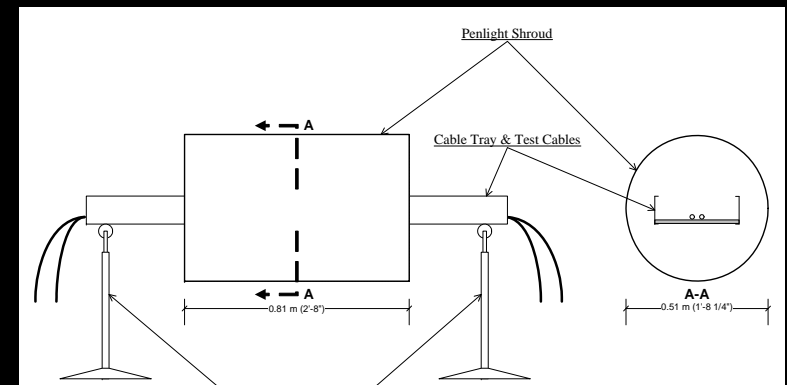



U.S. NRC
UNITED STATES NUCLEAR REGULATORY COMMISSION

Protecting People and the Environment

Benefits of working with EPRI

- 125Vdc Battery Bank from TSC
- Vintage (1970's) Kerite FR & HTK (FAQ 53)
- 200+ feet of armored cable
- 15kV circuit breaker
- Large coil (similar to PORV)
- 1" coil assembly (similar to head vent valve)



DESIREE-FIRE Program

Approach & Key Objectives

**2009 NEI Fire Protection Information
Forum, Savannah, Georgia**
September 20-24, 2009

Daniel Funk
Principal Engineer, Edan Engineering

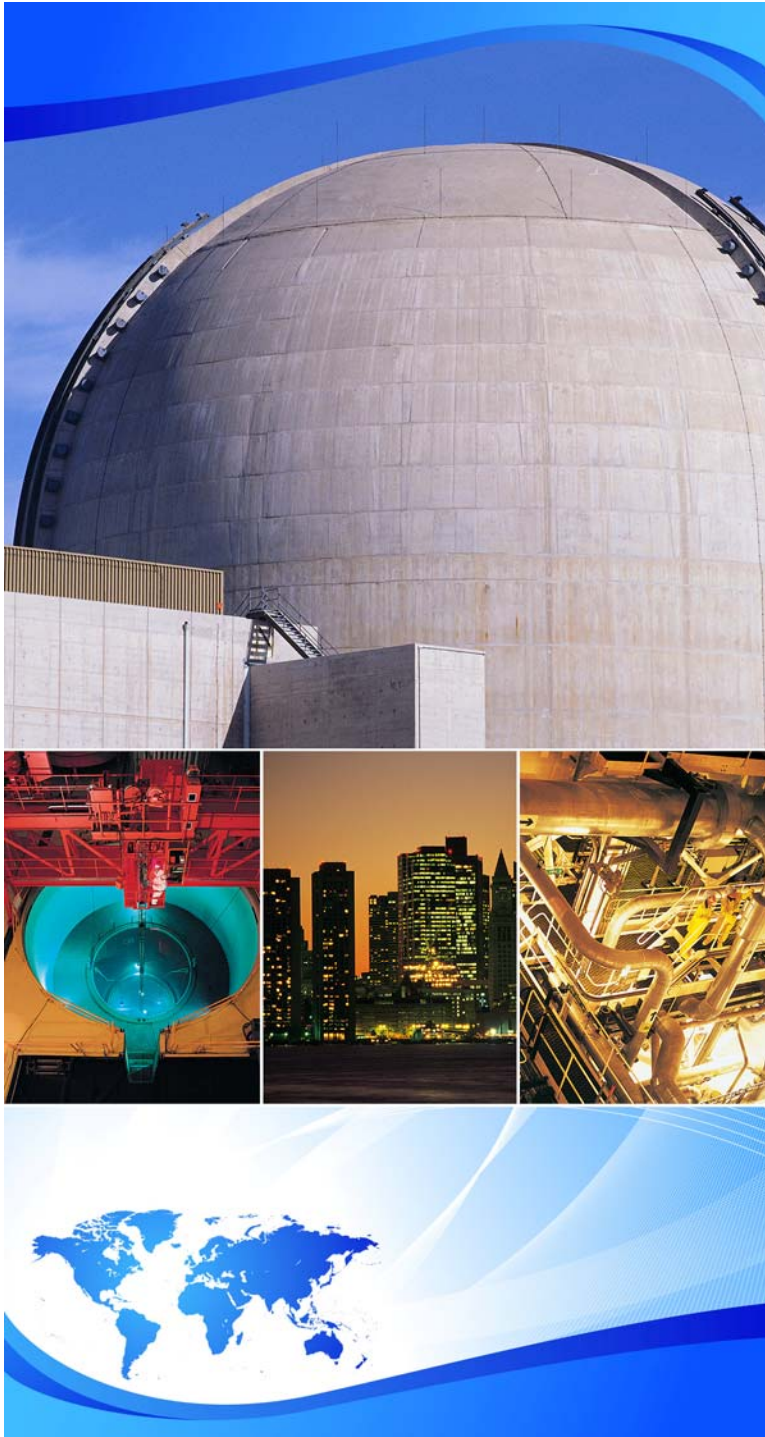

Topics

Approach

- Peer review group & industry participation
- Test configuration
- Conduct of test & data collection

Objectives

- Characterize DC
- Clean up lingering issues

Peer Review Group & Industry Participation

Active group

Representatives from NRC, Sandia, EPRI, & Industry

NRC has been very receptive to industry input

Industry has come through...but we need more

– **KERITE CABLE**

Test Configuration

Realistic Setup

- Large station battery
- Realistic cable lengths and sizes
- Typical “DC rated” protective devices
- Representative sample of equipment

Test Configuration



Test Configuration



Test Configuration



Test Configuration



Approach

Similar to CAROLFIRE

- Small-scale radiant exposure
- Intermediate-scale live fire tests

Numerous dc circuits evaluated

- DC motor starter (MOV)
- Small pilot DC SOV (ASCO red-hat)
- 15 kV circuit breaker (complete breaker assembly)
- 1" SOV
- Large coil (similar to PORV)
- Instrumentation loop

Approach & Scope

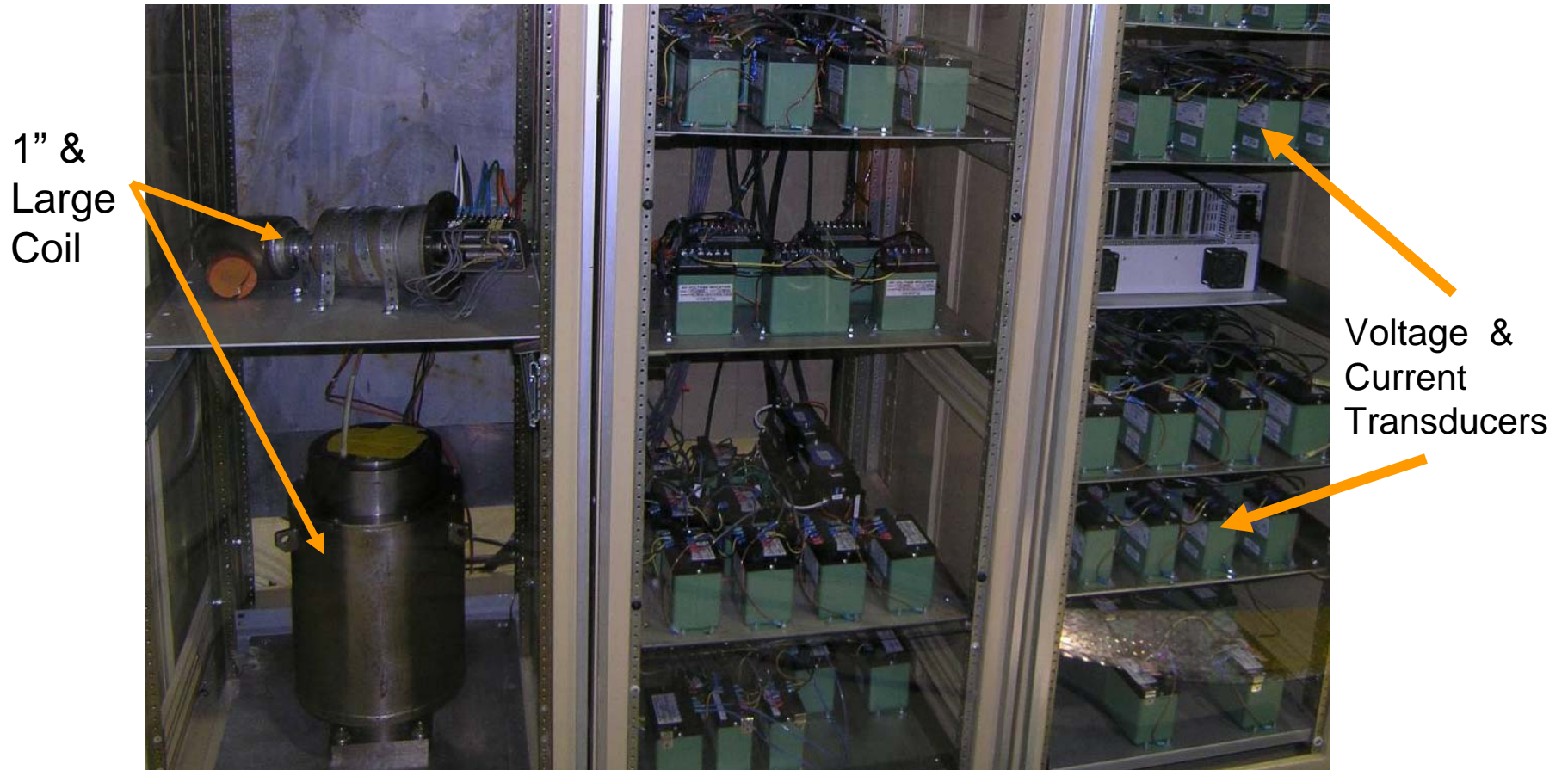

Test Circuit and Data Collection

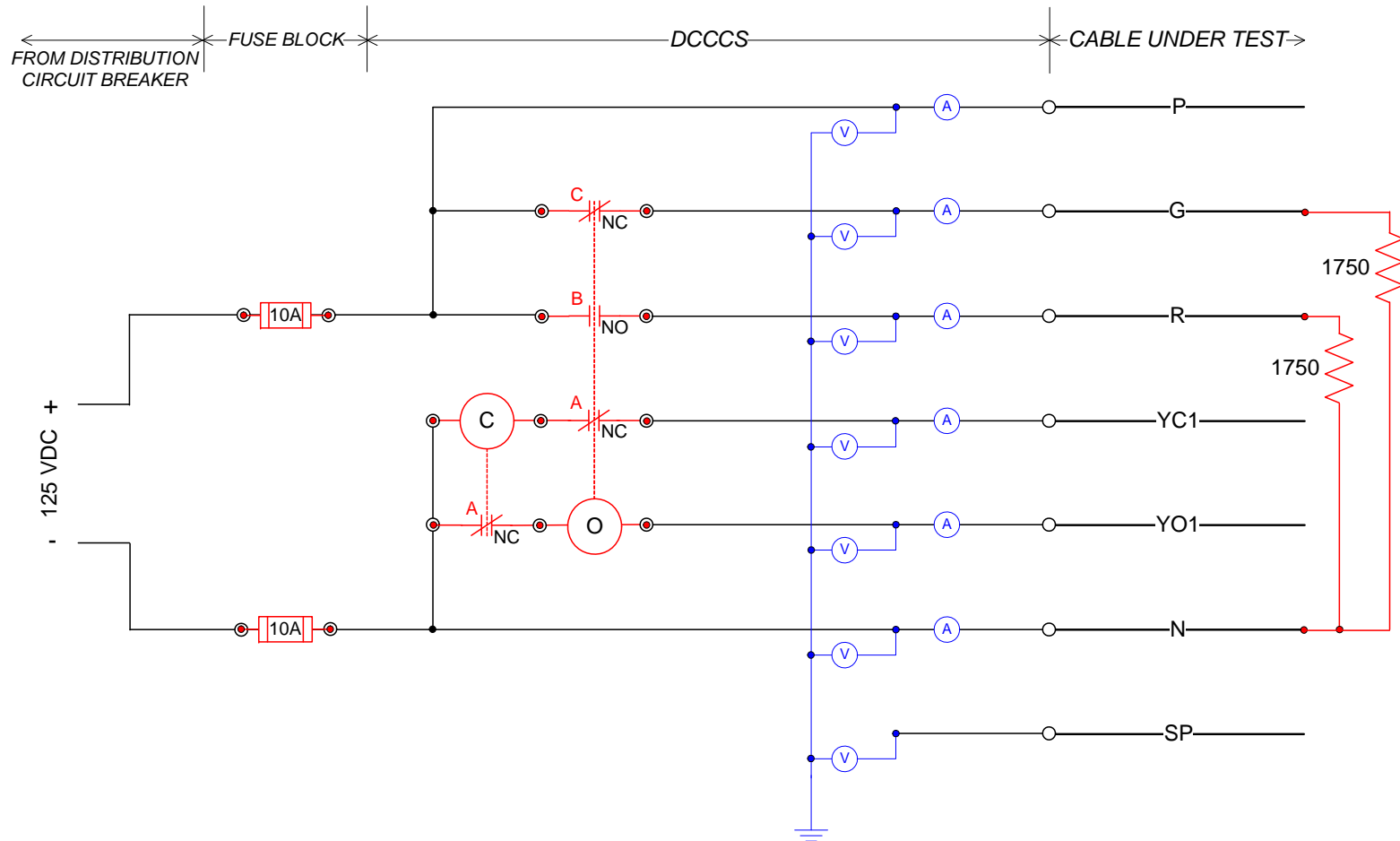

DCCCS Layout for DC MOV Control Circuit

Test Circuit and Data Collection

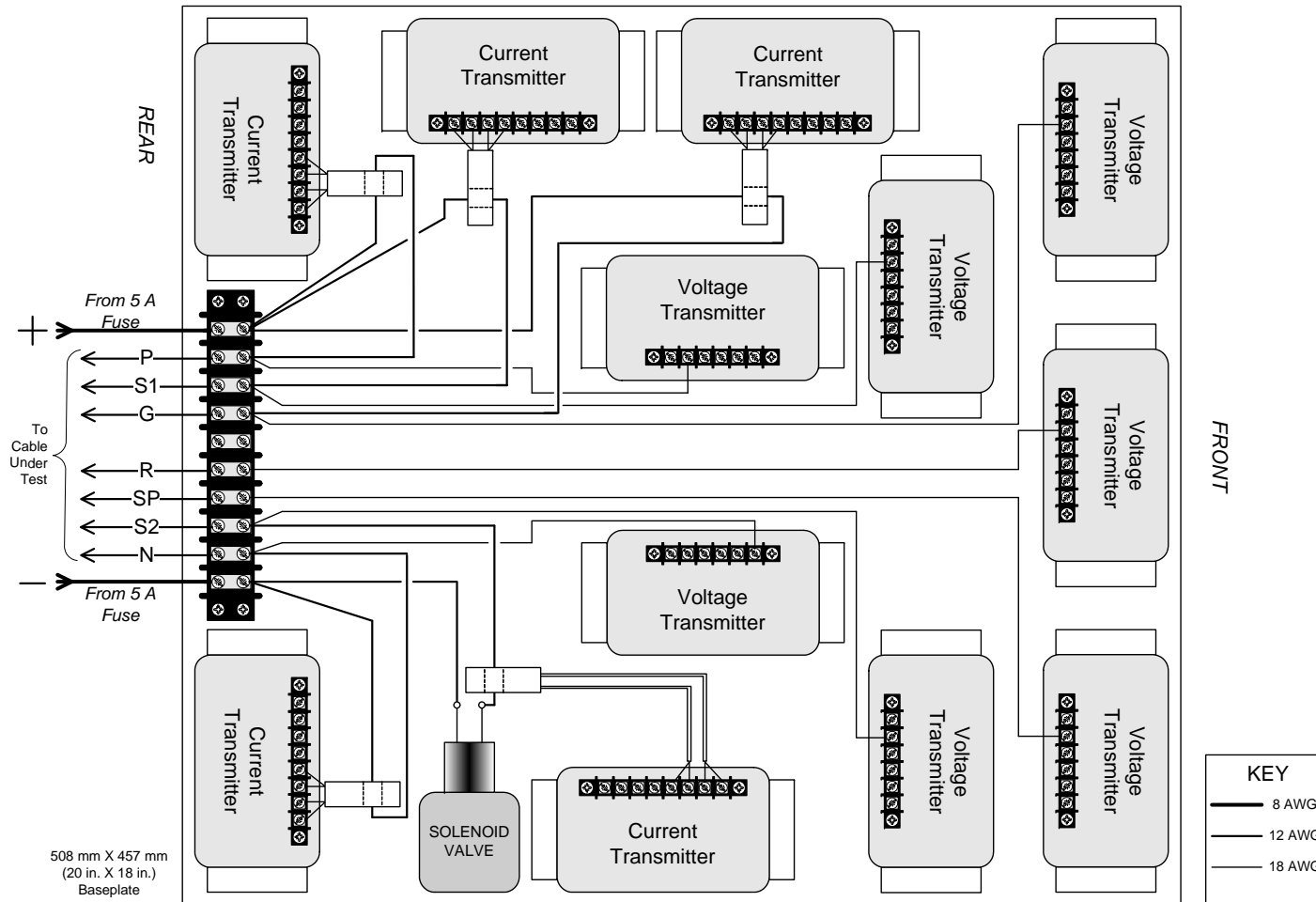

DCCCS COMPONENT LAYOUT FOR SMALL DC SOV CIRCUIT

Key Test Objectives

Characterize DC

- Realistic circuits and configuration
- Inter-cable shorting
- Interactions with ground plane
- Multiple proper-polarity, coincident hot shorting
- Ground detection circuit

Follow up testing

- Role of CPTs
- Kerite cable characteristics
- Instrument circuits

Objectives – Analysis of Data

What is Success?

- Adequate DC data and quality to support analysis
- Resolve CPR issue
- Resolve Kerite cable issue
- Better answer for inter-cable hot shorts of thermoset cable
- Definitive position/likelihood for multiple, proper-polarity



U.S.NRC
UNITED STATES NUCLEAR REGULATORY COMMISSION

Protecting People and the Environment

Preliminary Results

Harry Barrett

Senior Fire Protection Engineer

NRC/NRR



**Office of Nuclear
Regulatory Research**



*Fire Research
Branch* 



Preliminary Results

- Open Circuits

Open Circuit

Copper Slag





Preliminary Results (2)

- Arcing & Cable Ignition
 - Electrical failure appears to be more energetic than in AC testing
 - In most cases arcing appears to act as the pilot for cable ignition
 - Electrical arcing also appears to cause adjacent cables to ignite in some tests



Preliminary Results (3)

- Fuse sizing
 - Initial observations indicate that larger fuses (15-35A) take longer to clear than small 5-10A fuses
 - In some tests the 35A fuses did not clear, instead electrical arching caused an open circuit in cable conductors



U.S.NRC
UNITED STATES NUCLEAR REGULATORY COMMISSION

Protecting People and the Environment

15kV Circuit Breaker Test #29

Tefzel 7/c
12AWG

Breaker
Actuation

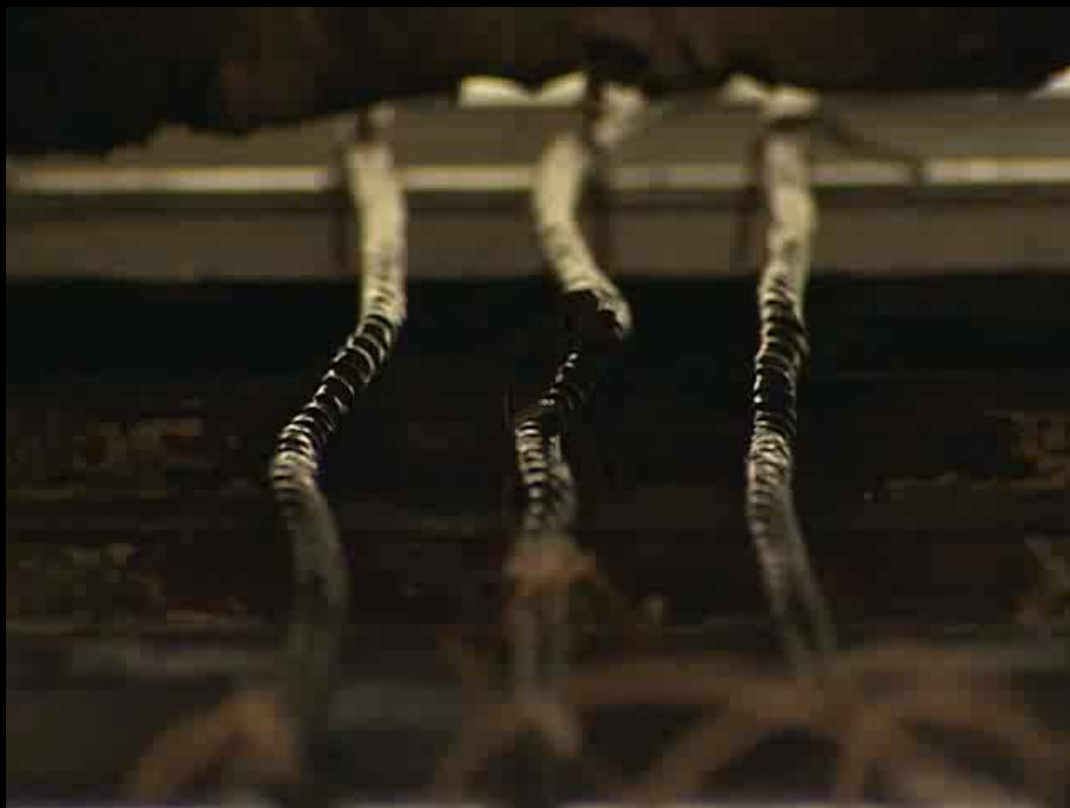



Preliminary Results (4)

- Grounding
 - DC battery bank is ungrounded
 - In at least one test, a fuse cleared on one test circuit with a subsequent spurious actuation
 - This could be possible by having the cable tray act as a conduction path between the energized and de-energized cables.
 - Analysis will be required to determine the root cause of this particular spurious actuation



Test Report

- NUREG/CR similar to CAROLFIRE report will contain test results, including all data files
- Report will not provide failure probabilities, but will provide summary tables



U.S. NRC
UNITED STATES NUCLEAR REGULATORY COMMISSION

Protecting People and the Environment

Follow-on Work

- Expert Elicitation and Phenomena Identification and Ranking Table (PIRT)
- PIRT will rank the importance of various aspects related to fire-induced cable damage





Objectives – Analysis of Data

- Expert Elicitation will re-evaluate original spurious op probabilities (EPRI Report 1006961)
- Incorporate DC results
 - Spend time to Re-evaluate DC motor starter (MOV)
 - Small pilot DC SOV (ASCO red-hat)
 - 15 kV circuit breaker (complete breaker assembly)
 - 1" SOV
 - Large coil (similar to PORV)
 - Instrumentation loop



U.S. NRC
UNITED STATES NUCLEAR REGULATORY COMMISSION

Protecting People and the Environment

Questions





EPRI

ELECTRIC POWER
RESEARCH INSTITUTE



EPRI/NRC-RES FIRE PRA METHODOLOGY

Task 12 – Fire Human Reliability Analysis

NEI Fire Protection Information Forum

September 2009

J.S. Hyslop, US NRC

Jeffrey Julius, Sciencetech/EPRI

A Collaboration of U.S. NRC Office of Nuclear Regulatory Research (RES) & Electric Power Research Institute (EPRI)

Outline of the Presentation

Overview of the EPRI/NRC Fire HRA Guidelines

- **Objectives/Tasks**
- **Fire HRA Guideline Summary:**
 1. Identification & definition of post-fire human failure events
 2. Qualitative analysis (timing, instrumentation, actions)
 3. Quantification methods:
 - a) Screening
 - b) Scoping
 - c) Detailed (EPRI approach & ATHEANA)
 4. Dependency & Uncertainty
- **Timeline**

Background on the Issue of Fire HRA

- Almost 50% of USA plants transitioning to NFPA-805
 - Using NUREG/CR-6850 for the Fire PRA Guidance
- NUREG/CR-6850 addresses:
 - Identifying human failure events (HFEs)
 - Assigning **conservative screening** human error probabilities (HEPs)
 - Post-fire Performance Shaping Factor (PSF) information
- NUREG/CR-6850 does not:
 - Describe a methodology for developing best-estimate HEPs (given fire related effects)
 - Address the requirements of:
 - **ASME/ANS RA-S-2009, “Standard for Level 1 / Large Early Release Frequency Probabilistic Risk Assessment for Nuclear Power Plant Applications,” Part 3 for fires**
 - **Consequently, there is a need for fire-specific guidance for best-estimate HRA quantification**

Overall Project Objectives

- Joint NRC and industry effort
- Address the need for HRA guidance
 - NUREG/CR-6850 limitations:
 - Identifies factors potentially affecting operator performance
 - Provides rough screening human error probabilities
 - Address best-estimate HEP quantification in fire PRAs
 - Developed methodology
 - Provided guidance for implementation
- Develop a joint EPRI/NRC report
 - Similar to NUREG/CR-6850

Project Tasks

1) Data collection

- Fire events (reviewed historical event data)
- Some plant interviews (with more during the testing phase)

2) Method Development:

- Started with a review of the EPRI Fire HRA Guideline
- Updated NUREG/CR-6850 screening for long time windows.
- Adding a Fire HRA Scoping method
- Detailed Fire HRA based on EPRI approach or ATHEANA

3) Peer reviews (2 planned)

4) Testing at plant sites

5) Documentation – in a joint NUREG/CR & EPRI report, similar to NUREG/CR-6850

Task 1 – Fire Data Review

- “Data” in a generic sense
- Used existing guidance & literature, such as:
 - PRA Standards (internal events & fire PRA)
 - NUREGs: NRC’s “Good Practices in HRA” (1792) & Fire Manual Actions (1852)
 - Draft EPRI Fire HRA Guidelines
- Started with NUREG/CR-6850 considerations of fire effects
- Verified these considerations (and identify any needs for updating):
 - Collected and reviewed recent NPP fire events
 - Collected and reviewed plant data
 - Considered a range of plant responses (fire response strategies).
 - Performed some plant interviews

Task 2 – Fire HRA Development

- Examined **HRA process**, identified how the process and tasks would change in a fire environment or accident response scenarios in response to a fire
 - Successive screening/quantification
- 3 categories of fire-related actions:
 - Existing post-initiator HFEs
 - Post-initiator fire response HFEs (including Main Control Room abandonment)
 - Undesired response to spurious cues or actuation
- Decided on a progressive approach for fire HRA quantification (reflecting fire PRA development):
 - Rough screening per NUREG/CR-6850 (**relaxed for late events**)
 - Scoping fire HRA approach (***newly developed***)
 - Detailed fire HRA quantification using EPRI's Cause-Based Decision Tree & HCR/ORE and/or NRC's ATHEANA (**modified for fire effects**)

Task 3 – Fire HRA Review & Testing

Peer Review:

- NRC and industry team with 7 reviewers:
 - NRC: Gareth Parry, Erasmia Lois, J.S. Hyslop
 - Industry: Stuart Lewis, Kenneth Kiper, Young Jo, Zouhair Elawar
- In general, was the **right approach** taken and implemented?
 - Is the technical approach sound and reasonable?
 - Are the selected HRA models appropriate for the application?
 - Are the assumptions presented in this methodology reasonable?
 - Does the guidance meet its stated objectives?

Testing

- Plant 1: Conducted in August 2008, tested flowcharts
- Plant 2: Conducted in September 2008, tested flowcharts

Fire HRA Guideline Summary: Objectives and Scope

- Identify/analyze **existing post-initiator** HFEs
- Identify/analyze **post-initiator fire response** HFEs
 - Includes Main Control Room abandonment
- Identify/analyze **post-initiator HFEs modeling response to spurious actuations and indications**
- Implement post-initiator fire HEPs in fire PRA model(s)
 - First quantification/screening and/or detailed fire PRA model
 - Including dependency analysis
- Out of Scope
 - Pre-initiators (per NUREG/CR-6850)
 - Fire brigade response (except for impacts on fire PSFs)

Fire HRA Guideline Summary

- Standard HRA **process** used for Fire HRA modeling:
- Fire HRA **steps**:
 1. **Identification & definition** of human failure events (HFEs):
 - Substantial guidance provided, including feasibility test
 - Feasibility Evaluation (Go / No-Go) example criteria
 - Sufficient time available to complete action
 - Sufficient manpower
 - Procedures & cues exist
 2. **Qualitative HRA analysis** described:
 - Certain activities required for all analyses; others only for specific detailed HRA method
 3. **Quantification**
 - **NUREG/CR-6850 screening**:
 - Refinement/relaxation for areas identified in NUREG/CR-6850 implementation

Fire HRA Guideline Summary (cont'd)

Fire HRA **steps**: (continued)

3. Quantification (cont'd)

- **Scoping Fire HRA** method added (new):
 - Developed to address the majority of HFEs, thereby conserving HRA resources
 - Guidance being developed to aid reproducibility & reviewability
 - Can be used for defined scenario contexts that are generalized & constrained with respect to PSFs
 - Current format: decision trees
- **Detailed Fire HRA**, existing methods with performance shaping factors modified for the fire scenario:
 - EPRI Cause-Based Decision Tree & HCR/ORE; & THERP
 - ATHEANA

4. Dependency (between actions) & Uncertainty

Fire HRA Project Timeline

- Project initiated: March 5, 2007
- First integrated draft: May 2008
- Peer review: June 2008
- Testing at 2 plants: Summer/Fall 2008
- Revised draft: April 2009
- Quick review by NRR & NRO: April 2009
- ACRS sub-committee information presentation: June 2009
- Piloting by PWR Owner's Group: Summer 2009
- Issued for public comment: **September 2009**
- Joint EPRI/NRC-RES as part of NUREG/CR-6850 Fire PRA Training Course: June/October 2009 (for information only)
- ACRS sub-committee presentation: **December 2009**
- Publication of final report: **Spring 2010**





BACK-UP SLIDES

EPRI/NRC Fire HRA Guidelines: Development Team

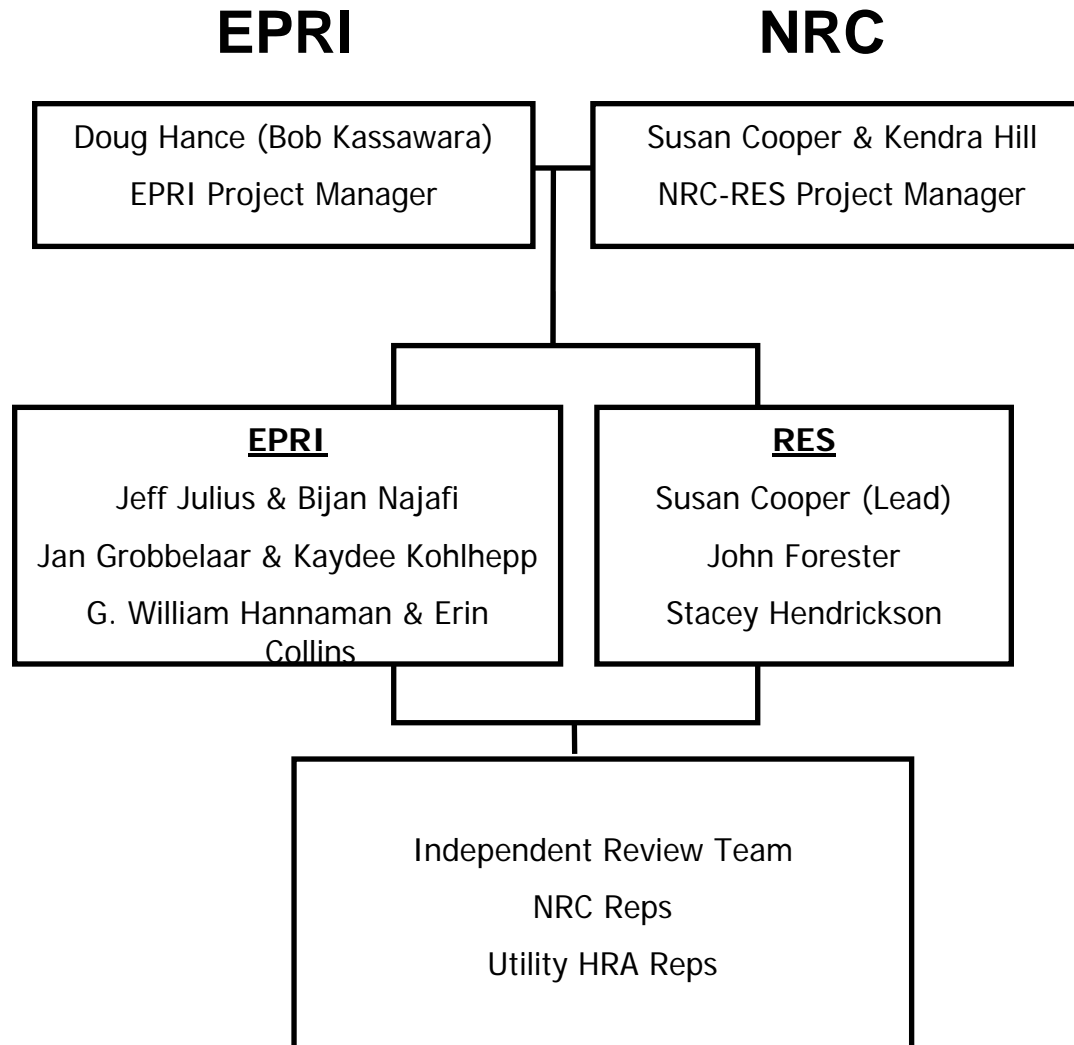

Categories of Fire Post-Initiator Operator Actions

- Existing internal events operator actions
 - From current Level1/LERF PRA model
- Fire response operator actions
 - New actions per fire procedures
 - New actions to address recovery of spurious actuation
 - MCR abandonment is a subset of fire response actions
- HFEs Corresponding to Undesired Operator Responses
 - New actions to address undesired operator actions in response to spurious indications per Part 3 on Internal Fires in ASME/ANS Combined PRA Standard

Performance Shaping Factors

- Cues and Indications
- Timing
- Procedures and Training
- Complexity
- Workload, stress, pressure
- Human-Machine Interface
- Environment
- Special Equipment
- Crew Communication, Staffing and Dynamics

Example of Fire Specific Context Definition

Description: Locally open valve (8804A) for high pressure recirculation following a spurious PORV LOCA

1. Initial Conditions: Steady state, full power
2. Initiating Event:
 - Fire in Area 5A2
 - The fire starts in transformer and impacts targets in the plume and vertical trays adjacent to the flames.
 - PORV spuriously opens resulting in small LOCA
3. Accident sequence (preceding functional failures and successes):
 - Reactor trip, Turbine trip
 - No containment spray required
 - AFW successful
 - SSPS not impacted
 - SI actuates due to open PORV
 - Cooldown and depressurization required.
 - Switch over to recirculation required.
 - Valve 8804A failed to open from CR due to fire damage.

Example of Fire Specific Context Definition

- Continued

4. Preceding operator error or success in sequence:

Operators fail to detect spurious PORV opening prior to auto SI actuation

Operators controlled ECCS flow to match make-up flow with leakage rate

RHR pumps tripped

Cooldown and depressurization either failed or failed to be completed before RSWT reaches 33%

5. Operator action success criterion:

Locally open 8804A and B located at 73' RHR Access or 100' GE - 8804A failed to open from CR due to fire damage

6. Timing

Time to RWST 33 % = 180 minutes

Time to RWST 0% = 268 minutes

Time required to perform local valve operations = 25 minutes

Example of Fire Specific Context Definition

- Continued

7. Consequence of failure: Core damage

8. Availability of Cues and Indications:

- RCS Pressure decreasing would be the primary cue operators would be focused on for diagnosing stuck open PORV. RCS pressure indicators are not failed by the fire
- RWST Level indications not impacted by fire
- Monitor light boxes: The indicators at the switch would not be available to alert the operators that the valve failed to close but the monitor light boxes would be giving conflicting information and the operators tend to look at both the position switch and the monitor light boxes

Timing Example

Description: Locally open valve (ID 1234) for high pressure recirculation following a spurious PORV LOCA

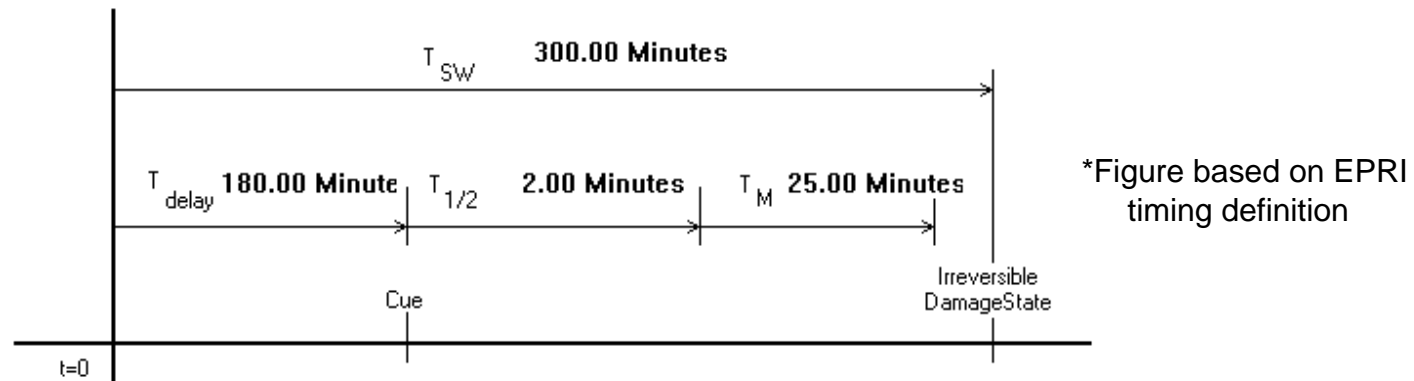

- T_{sw} - 300 min. Time to RWST depleted
- $T_{\text{delay}} = 120$ switchover to recirc. RWST <33%
- $T_w = 300 - 120 = 180$ min
- $T_{1/2}$ (T_d) = 2 minutes. Estimated time attempt to close CR switch and relies that valve must be closed locally.
- $T_m = 25$ minutes from operator interviews

Time Margin Calculation

$$TM = \frac{t_w - (t_d + t_m)}{(t_d + t_m)} * 100\%$$

$$\frac{180 - (2 + 25)}{2 + 25} * 100 \sim 566\%$$

Three General Approaches to Quantification

- Screening: Slightly modified from NUREG/CR-6850 to cover long-term events
- New Scoping fire HRA quantification approach
 - Less conservative than screening, but designed to be slightly more conservative than detailed approaches
 - Some actions may not be able to meet some of the criteria (result in an HEP of 1.0)
- Two Detailed HRA quantification approaches modified for application in fire scenarios
 - EPRI Cause-Based Decision Tree (CBDT) HRA Calculator
 - ATHEANA





Together...Shaping the Future of Electricity



U.S.NRC
UNITED STATES NUCLEAR REGULATORY COMMISSION

Protecting People and the Environment

DRAFT NUREG-1924

The History of Electric Raceway Fire Barrier Systems (ERFBS) Used to Protect Post-Fire, Safe-Shutdown Functions in United States Nuclear Power Plants

2009 NEI Fire Protection Information Forum

Savannah, Georgia

Gabriel Taylor



**Office of Nuclear
Regulatory Research**





Purpose

- Documents the completion and closure of ERFBS used in NPPs to protect post-fire safe-shutdown functions, including;
 - History
 - Regulations and guidance
 - Performance issues
 - Testing Standards
 - Regulatory compliance
 - Individual plant use





Barriers Evaluated

- Kaowool
- Thermo-Lag
- 3M Interam
- Hemyc
- Versawrap
- Pyrocrete
- Concrete
- FP-60
- Darmatt KM-1
- Mecatiss
- MT
- Promat
- Pabco



Report Contents

- Chapter 1-4 provide background information on
 - Browns Ferry Fire, Regulations, and Development of ERFBS testing criteria
- Chapter 5 evaluates individual ERFBS
 - Consolidates documentation regarding all know ERFBS including their;
 - Effectiveness
 - Parameters affecting performance
 - Fire endurance testing
 - NRC closure of open items
- Only publically available information





Chapter 6

- Plant Specific Usage and Resolution of ERFBS
 - Provides information on the use of ERFBS at each of the operating U.S. NPPs
 - Information collected from publically available docketed materials
 - Information is “to the best of our knowledge”
 - May not have all of the information





U.S. NRC
UNITED STATES NUCLEAR REGULATORY COMMISSION

Protecting People and the Environment



To review your plant specific information
and provide comments during the public
comment period



U.S.NRC
UNITED STATES NUCLEAR REGULATORY COMMISSION

Protecting People and the Environment

Public Comment Period

- 60-days
- Ends November XX, 2009
- See Federal Register XX FR XXXX



U.S. NRC
UNITED STATES NUCLEAR REGULATORY COMMISSION

Protecting People and the Environment

Questions





U.S.NRC
UNITED STATES NUCLEAR REGULATORY COMMISSION

Protecting People and the Environment

Fire Research Activities at the Nuclear Regulatory Commission

NEI Fire Protection Information Forum

September 21 – 24, 2009

Hyatt Savanna, GA.



**Office of Nuclear
Regulatory Research**



Mark Henry Salley P.E.
Fire Research Branch
Markhenry.Salley@nrc.gov
301-251-7613

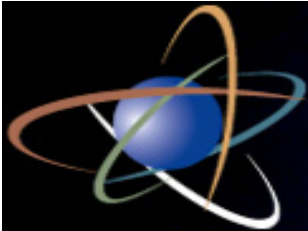

Major Program Areas

- Fire Modeling for NPP Applications
- Fire Probabilistic Risk Assessment (PRA)
- Fire Human Reliability Assessment (HRA)
- Direct Current (DC) Circuit Testing & Follow-on Circuit Analysis Work
- Electrical Cable Combustibility Properties
- Fire Research Knowledge Management
- Non-Reactor Projects





A Word on Collaboration

- Takes place in a number of different forms/venues
 - Memorandum of Understanding (MOU)
 - Electric Power Research Institute (EPRI)
 - International Agreements
 - Organization for the Economic Co-Operation and Development (OECD) Nuclear Energy Agency (NEA)
 - Developing a Working Agreement with Japan (JNES)
- National Laboratories
 - National Institute Standards and Technology (NIST)
 - Sandia, Idaho & Brookhaven DOE National Laboratories
- Collaboration with Other Federal Agencies & Universities
 - NASA, Navy, ATF, University Maryland
- Peer-Reviews, ACRS and Public Comment Periods





Fire Modeling Program Overview

- Four step process:
 - NUREG-1805 Introduction to Fire Dynamics in NPP applications (December 2004)
 - NUREG-1824 Fire Model Verification & Validation (V&V) (May 2007)
 - NUREG/CR-6978 Fire Model Phenomena Identification Ranking Table (PIRT) (November 2008)
 - Fire Model Users Guide for NPP applications
 - About to be released for Public Comment
- Future Improvements & Revisions





Fire PRA: Implementation of NUREG/CR-6850

- NUREG/CR-6850 (EPRI 1011989) being used extensively in NFPA 805 NPP transitions
- RES/EPRI worked fire PRA FAQs related to implementation of Fire PRA
- NUREG/CR-6850 remains best available overall fire PRA methodology
 - Fire PRA continues to evolve
 - Supplement current revision
 - When has the State-of-the-Art advanced to point where a full Revision is warranted?





Fire PRA Training

- RES/EPRI conducted two detailed fire PRA training courses in June and October of 2009 in Palo Alto, CA and Richmond VA.
 - Averaging 100+ attendees; Modules conducted in:
 - Fire – frequency, suppression, and elements supporting fire damage assessment
 - Electrical circuits – Circuits and spurious operations, including probabilities
 - PRA – modification of internal events model for fire
 - HRA – will be expanded based on the Fire HRA project
 - RES/EPRI will conduct fire PRA training next year (2010) in Bethesda, MD Area





Quantitative HRA Guidance

- Detailed quantitative methodology tailored to the performance of post-fire HRA at power operations
 - Scoping and detailed approaches
 - Extension of the work done in NUREG/CR-6850
- Enhance reproducibility and defensibility of analyses
- Peer reviewed in June 2008 by a panel of experts from industry and NRC
- Testing of guidance performed at two NPPs
- Joint RES/EPRI document to be issued for public comment before the end of 2009
- Inclusion in the RES/EPRI Fire PRA Training Program

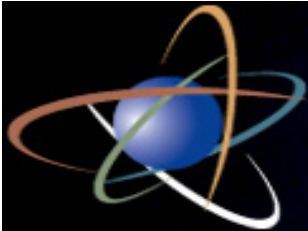

Direct Current (DC) Circuit Testing & Circuit Analysis Programs

- DC testing is in process
 - Expanded Program to include EPRI
 - Modified existing MOU
- After Completion of DC testing, NRC will be performing:
 - Expert Elicitation
 - PIRT





Cable Combustibility Testing

- Assembled large stock of representative cable at NIST
- Collect data on Ignition, HRR, flame spread for different cable types/ different configuration
- Phase I ongoing at NIST in 2009
- Phase II will start in 2010
- Phase III & IV under development



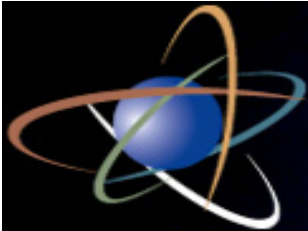

Fire Research/Regulation Knowledge Management

- Three Main Parts:
 - Browns Ferry Fire NUREG/BR-0361 (February 2009)
 - Short History NRC Fire Research NUREG/BR-0364 (June 2009)
 - Fire Regulations and Research NUREG/BR-XXXX (Winter 2009) (Currently known as RIC CD)
 - Over 30 years of information assembled in two main areas:
 - Regulations
 - Research
 - Older reports were difficult to recover
 - Adding to Electronic Data Base
 - Plan to Update & Expand annually for RIC



International Projects

- OECD Fire Events Data Base
- Fire Modeling
 - OECD PRISME
 - Collaborative Fire Modeling
- Exploring High Energy Arcing Faults





New Project Starts/ Other Projects Under Consideration

- Compensatory Measures
- Additional Fire Model Validation Data
- Fire Events Data Base
- Low Power Shutdown Fire PRA
- Documentation of ERFBS Issue
- Incipient Detection Systems



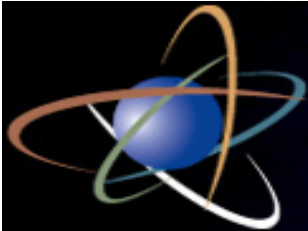

New Project Starts/ Other Projects Under Consideration

- Electrical Cabinet Heat Release Rates
- Gaseous Fire Suppression Agents
- Smoke Effects on Electronics
- Fire Effects on Fiber Optics Cable and Digital I&C





“Back-Burner” Projects

- Supplement 1 NUREG-1805
 - Add THIEF Spreadsheet
 - Upgrade all Existing Spreadsheets
- Methods for Applying Risk Analysis to Fire Scenarios (MARIA FIRES)
 - On Line Learning Program based on the 2008 NRC RES-EPRI Fire PRA Training





Non-Reactor Projects

- Red Oil
- LWT Shipping Cask Fire Testing beyond Design Basis
- Development of an SDP type tool for Fuel Fabrication Facility Inspections



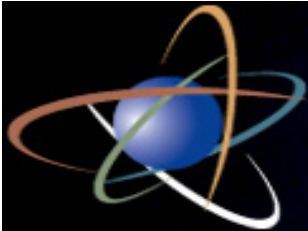

Conclusion

- NRC/RES actively engaged in Fire Research Activities
 - Research Products often support the broader Fire Protection Engineering Community
- NRC/RES always willing to partner with other Agencies/Organizations to support similar safety missions.

