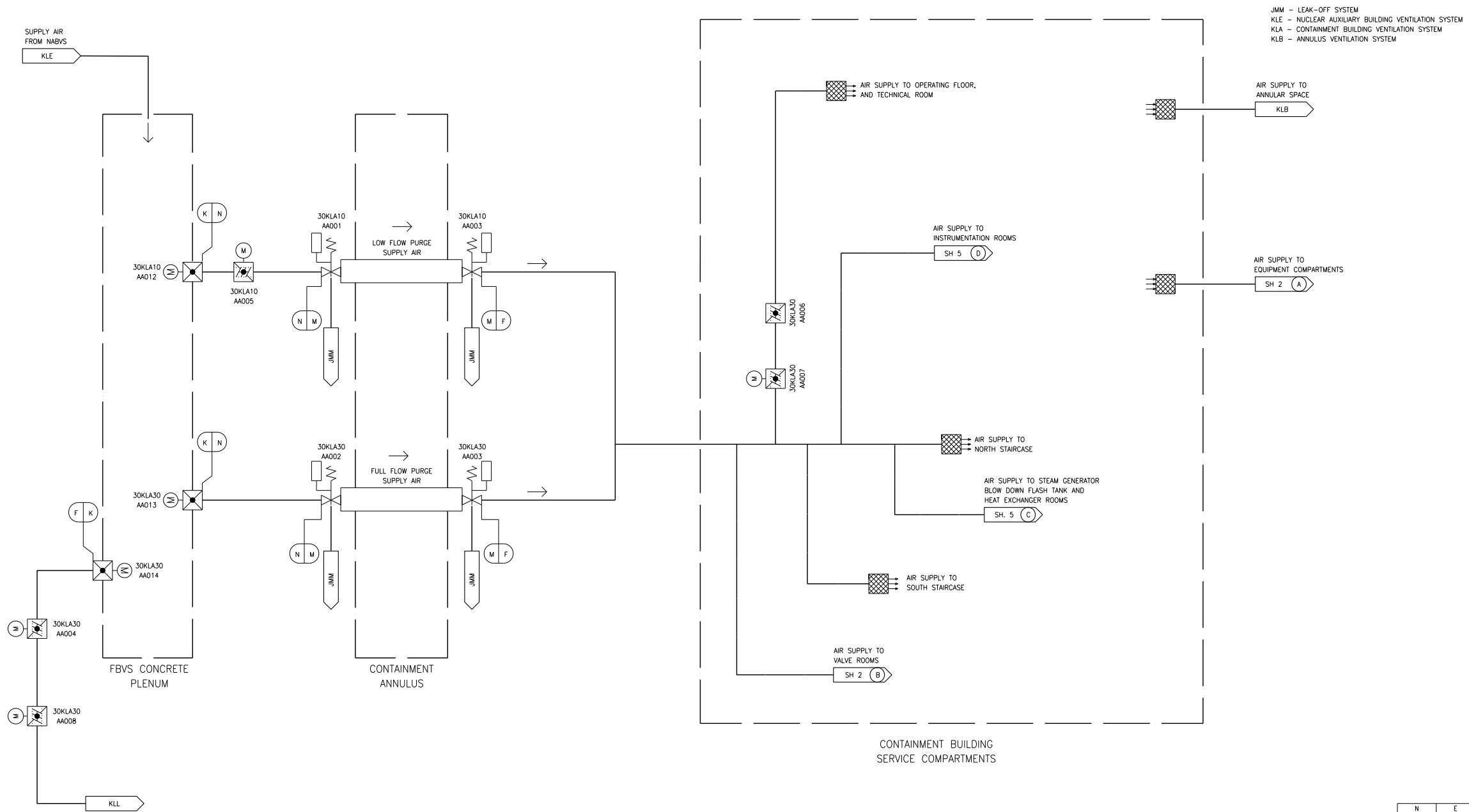

Figure 9.4.7-1—Containment Building Low Flow and Full Flow Purge Supply Subsystem



N	E	NSC
M	C	I
K	D	II
F	D	II
DESIGN AREA	SSC QUALITY GROUP	SSC SEISMIC CLASS

KLA01T2

Figure 9.4.7-2—Containment Building Low Flow and Full Flow Purge Exhaust Subsystem

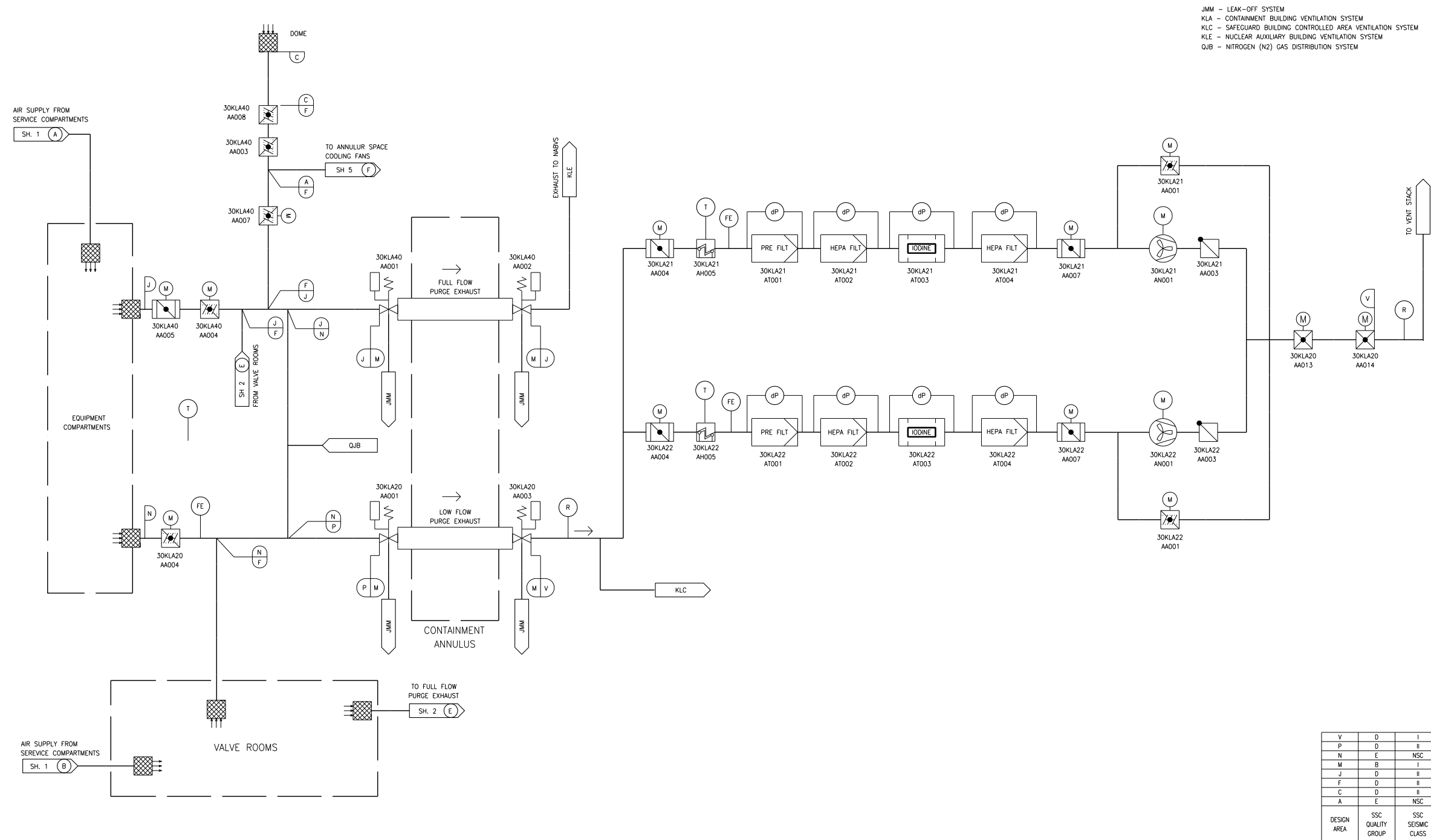

REV 001
 KLA02T2

Figure 9.4.7-3—Containment Building Internal Filtration Subsystem

KLE - NUCLEAR AUXILIARY BUILDING VENTILATION SYSTEM
 KLA - CONTAINMENT BUILDING VENTILATION SYSTEM

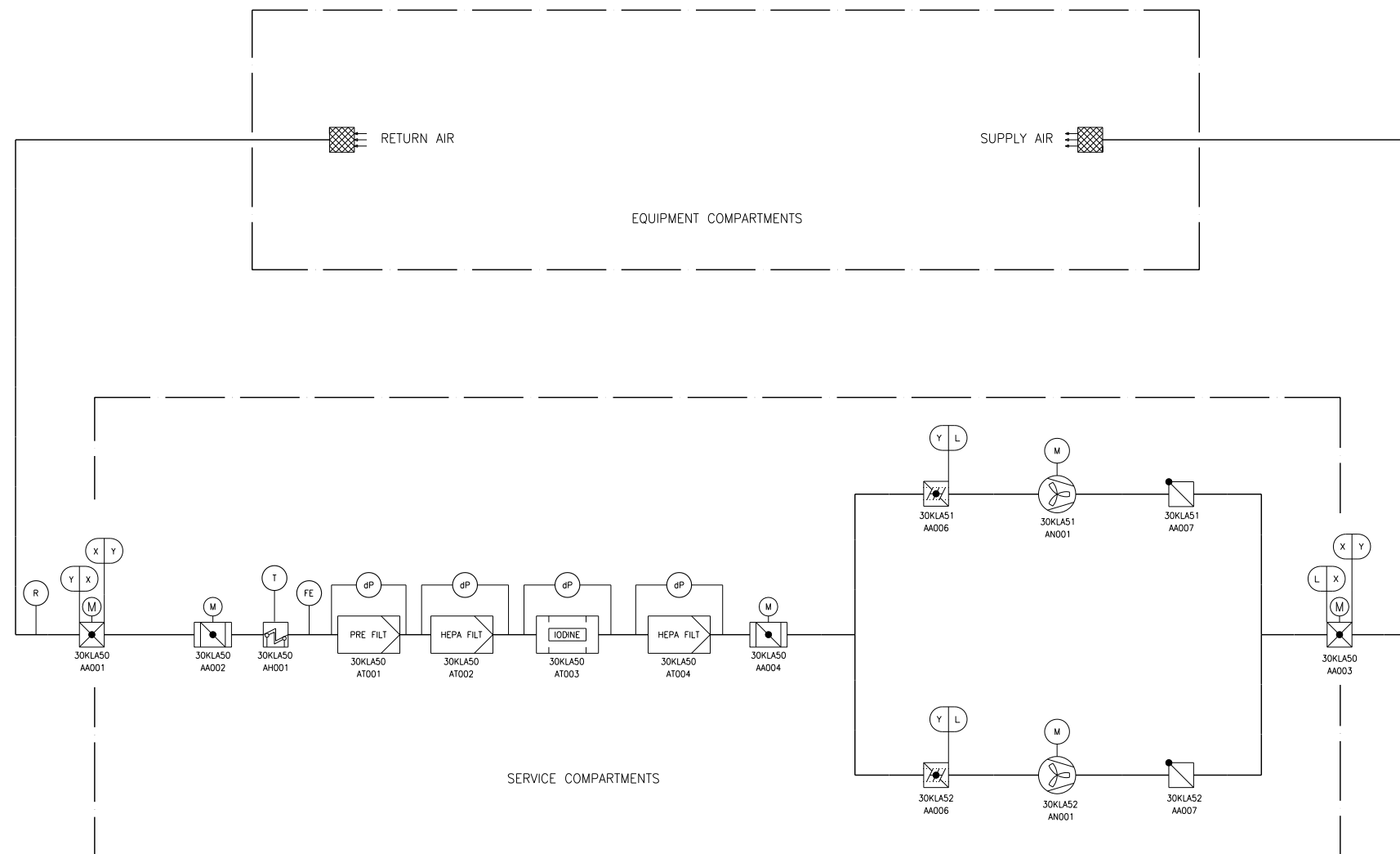

Y	D	I
X	D	I
L	D	I
DESIGN AREA	SSC QUALITY GROUP	SSC SEISMIC CLASS

REV 001
 KLA03T2

Figure 9.4.7-4—Containment Building Cooling Subsystem

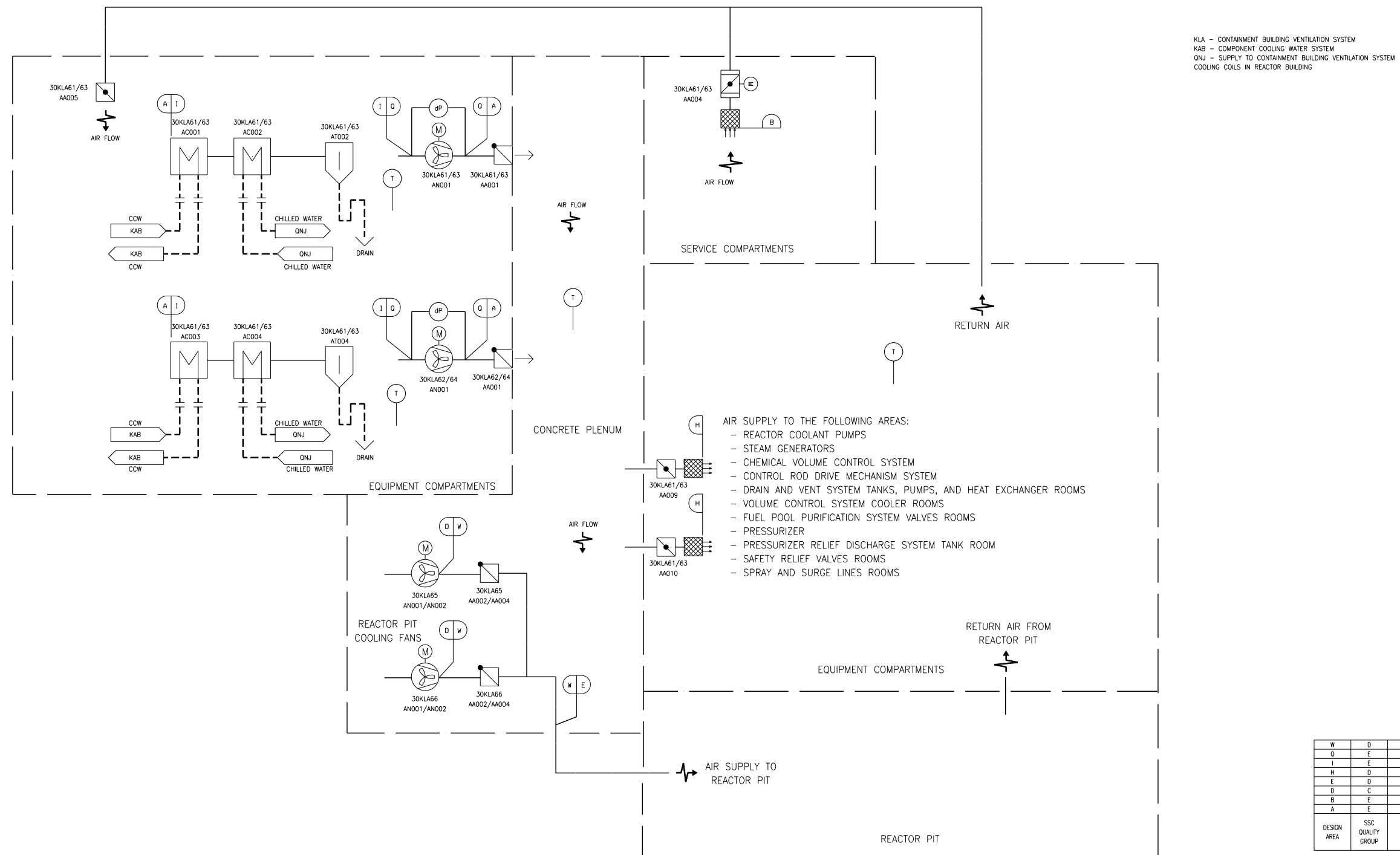

REV 001
KLA04T2

Figure 9.4.7-5—Containment Building Service Compartments Cooling Subsystem

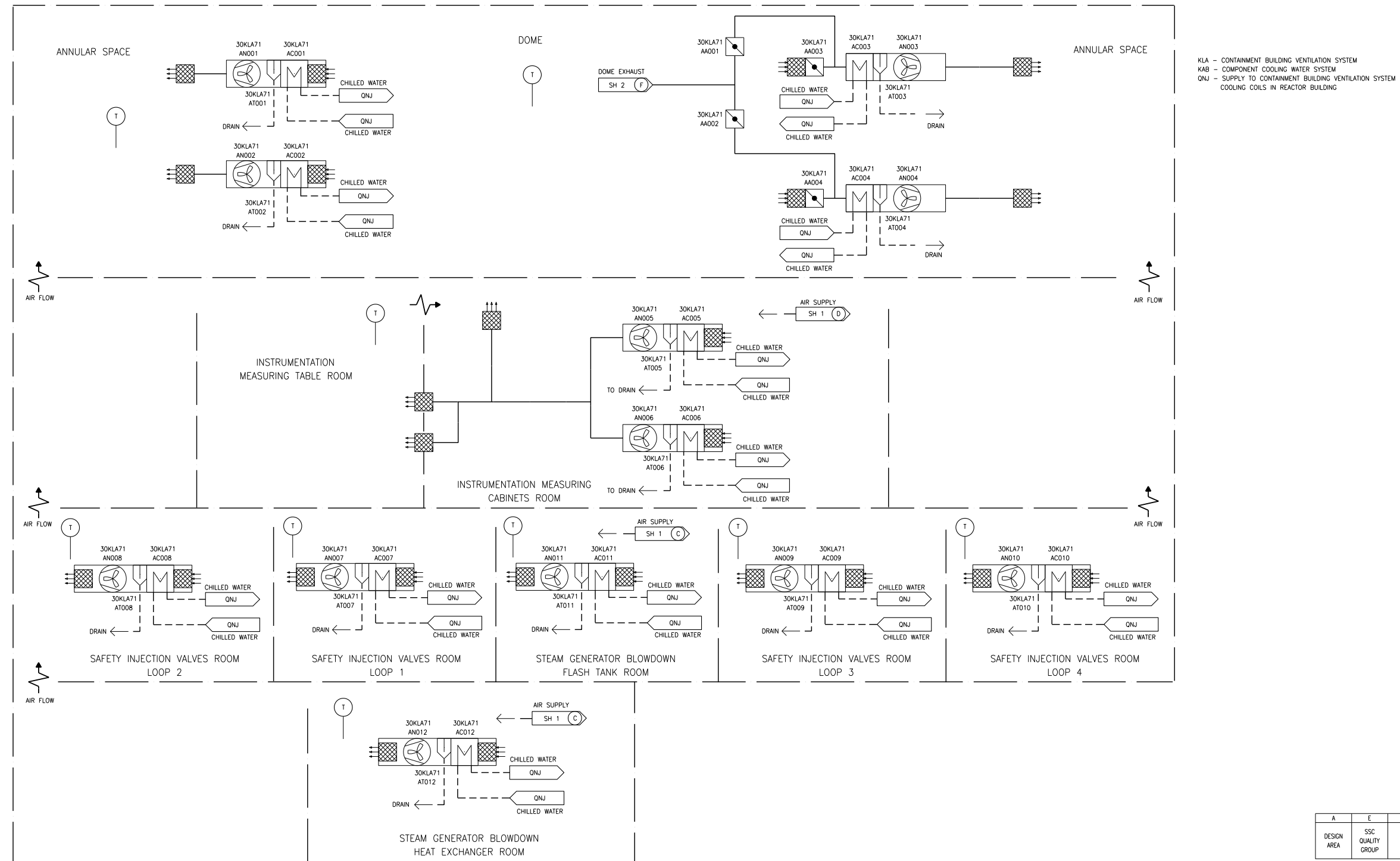

A	E	NSC
DESIGN AREA	SSC QUALITY GROUP	SSC SEISMIC CLASS

KLA05T2