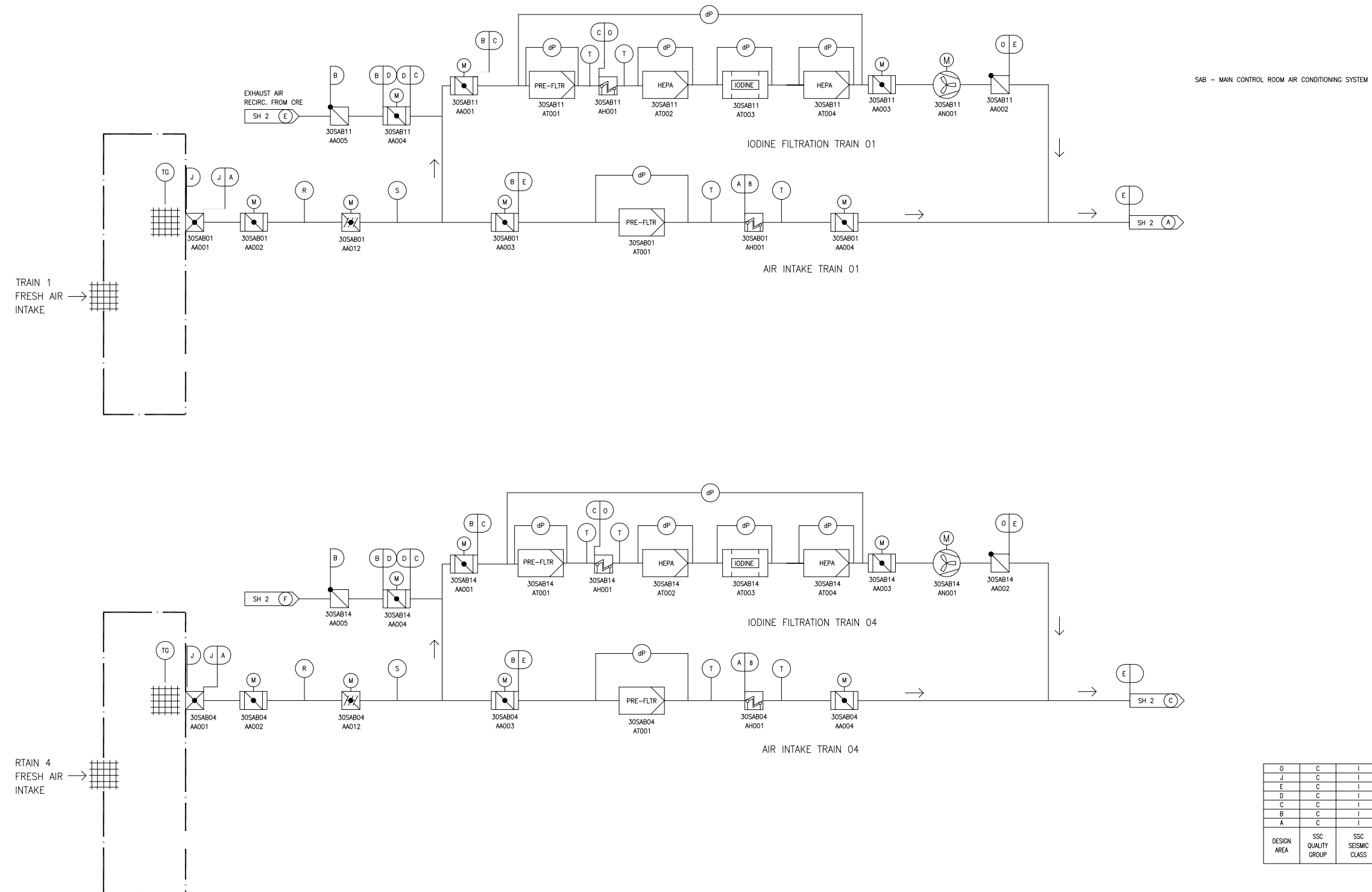

Figure 9.4.1-1—Control Room Air Intake and Iodine Filtration Train Subsystems



O	C	I
J	C	I
E	C	I
D	C	I
C	C	I
B	C	I
A	C	I
DESIGN AREA	SSC QUALITY GROUP	SSC SEISMIC CLASS

TG-Toxic Gas Sensors

REV 001
SAB01T2

Figure 9.4.1-2—Control Room Recirculation Air Handling Subsystem

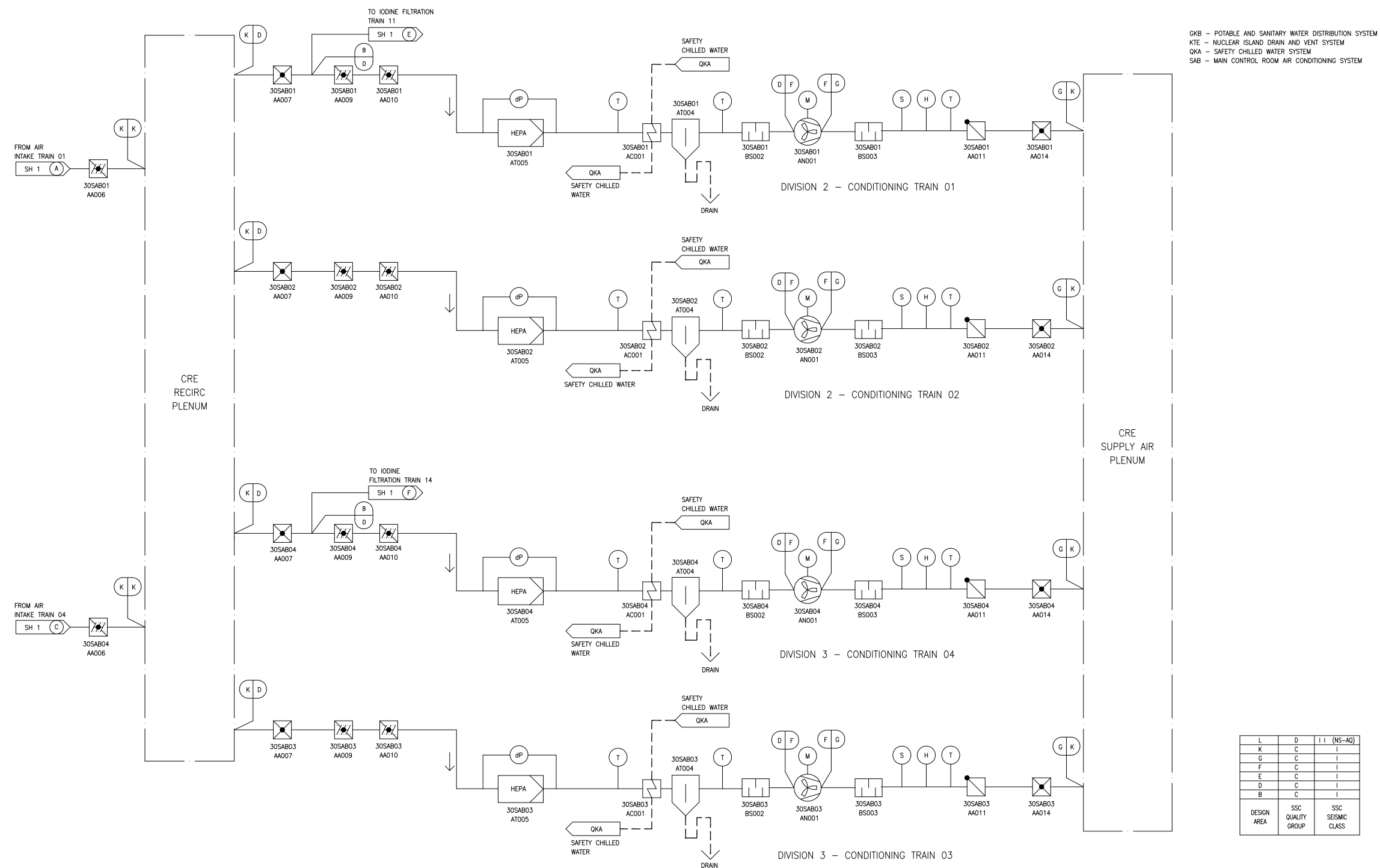

REV 001
SAB02T2

Figure 9.4.1-3—Control Room Envelope Air Supply and Recirculation Subsystem

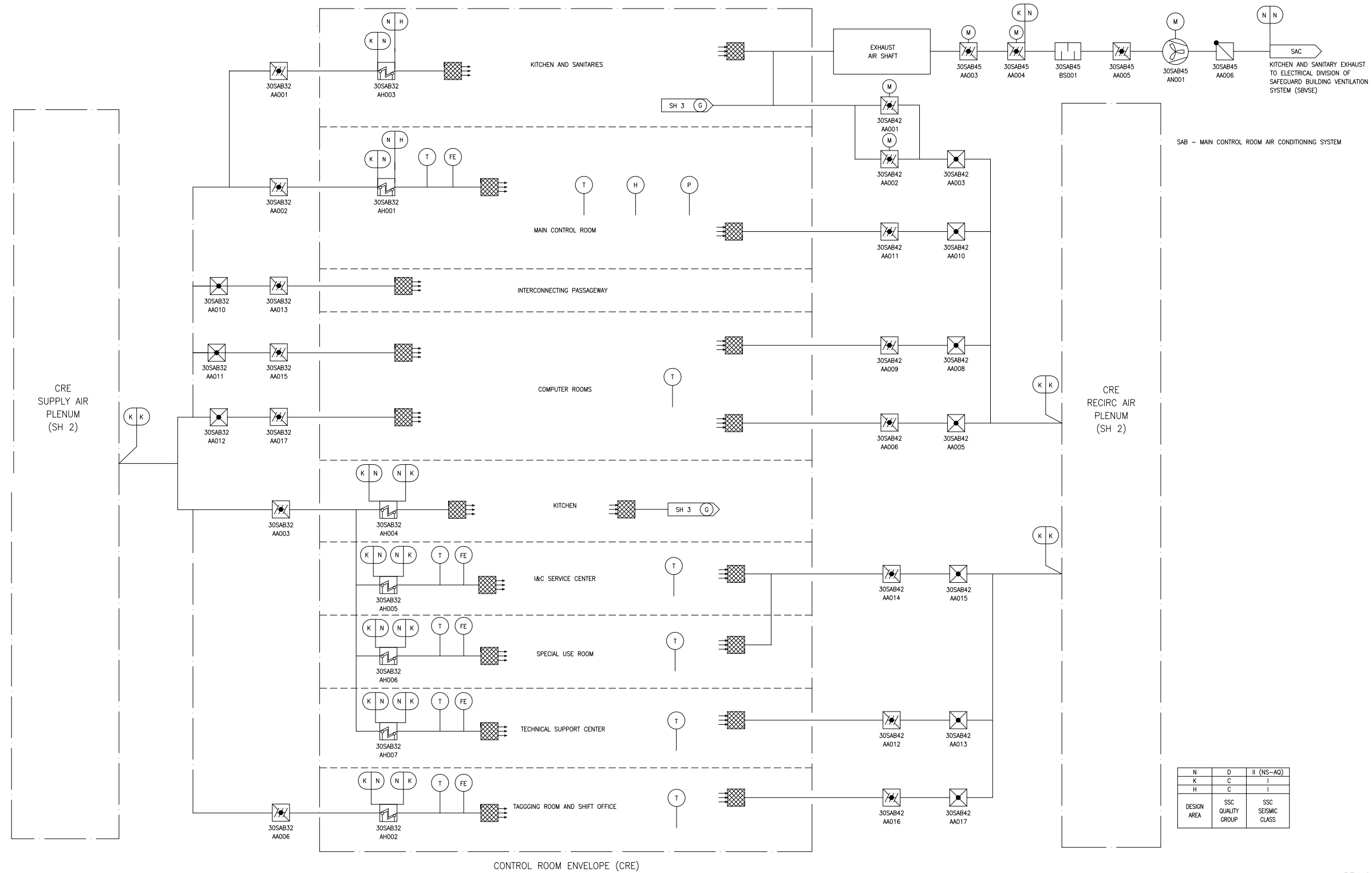

REV 001
SAB0312