

Figure 8.3-1—Electrical Single Line Drawing Legend

	ELECTRICALLY OPERATED DRAWOUT (EODO) CIRCUIT BREAKER, 3 POLE		WYE CONNECTED, GROUNDED SOLID
	LOW VOLTAGE CIRCUIT BREAKER		WYE CONNECTED, RESISTANCE GROUNDED
	CONNECTOR BETWEEN COMPONENTS ON SEPARATE DRAWINGS		DELTA CONNECTED
	CONNECTOR BETWEEN COMPONENTS ON SAME DRAWING		MOTOR LOAD
	GENERATOR, WYE CONNECTED		STATIC LOAD
	DRY TYPE TRANSFORMER		WYE CONNECTED, HIGH RESISTANCE GROUNDING THROUGH NEUTRAL DISTRIBUTION TRANSFORMER.
	VOLTAGE REGULATING TRANSFORMER		AC TO DC CONVERTER
	OLTC TRANSFORMER ONAN/ONAF/ONAF (SEE NOTE 1)		DC TO DC CONVERTER
	HIGH RESISTANCE GROUNDING THROUGH NEUTRAL DISTRIBUTION TRANSFORMER		INVERTER WITH STATIC BYPASS SWITCH
	FUSED DISCONNECT SWITCH		DIODE
	BATTERY		S.A. SURGE ARRESTER

NOTE:

1. THE ONAN/ONAF/ONAF NOTATION SHOWS THAT THE TRANSFORMER HAS TWO SETS OF FANS FOR COOLING. SEE IEEE C57.12 FOR ADDITIONAL INFORMATION ON TRANSFORMER RATINGS ASSOCIATED WITH COOLING METHODS.

LEGEND01T2

Figure 8.3-2—Emergency Power Supply System Single Line Drawing
Sheet 1 of 3

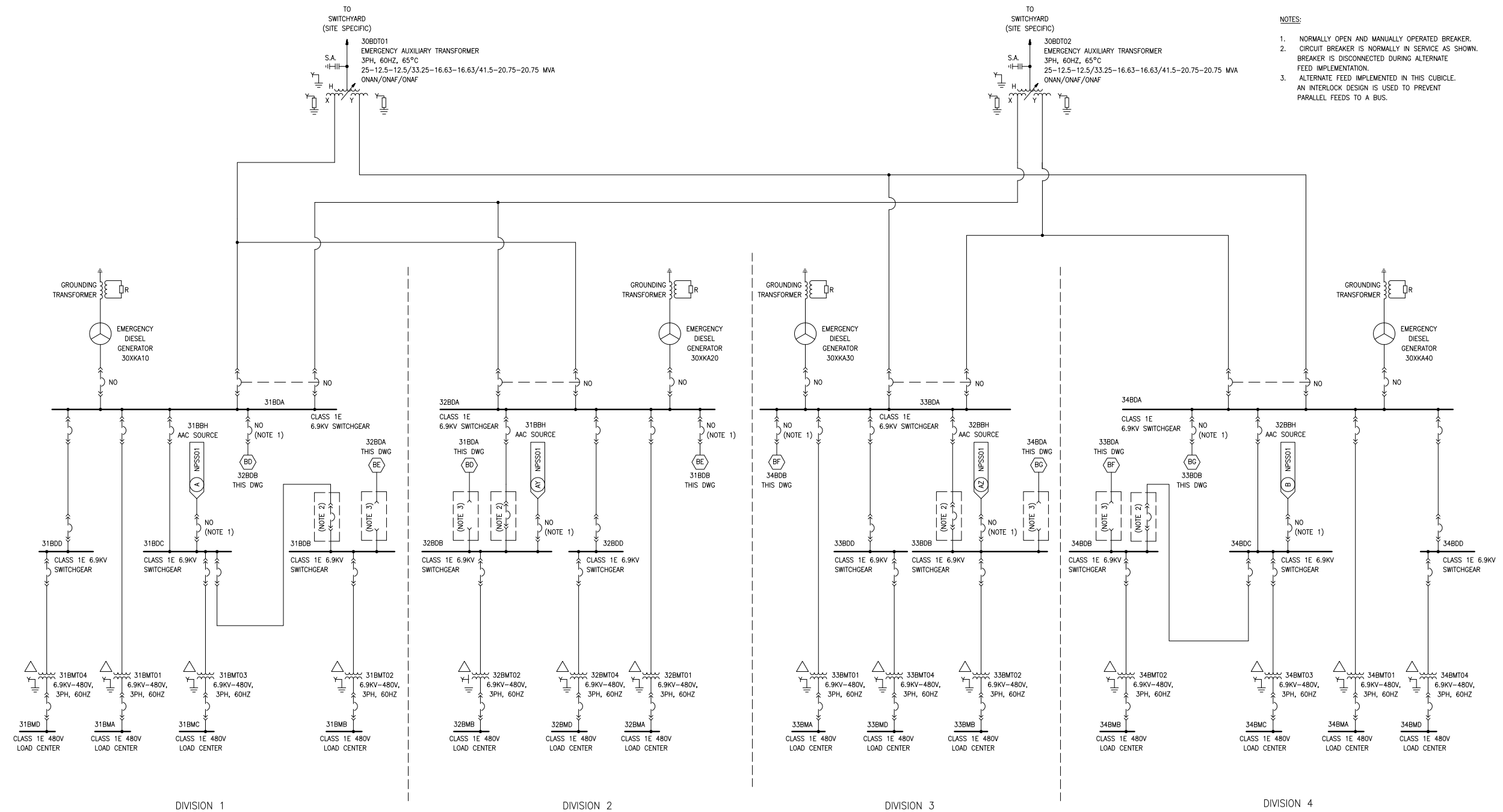

EPSS01T2

Figure 8.3-2—Emergency Power Supply System Single Line Drawing
Sheet 2 of 3

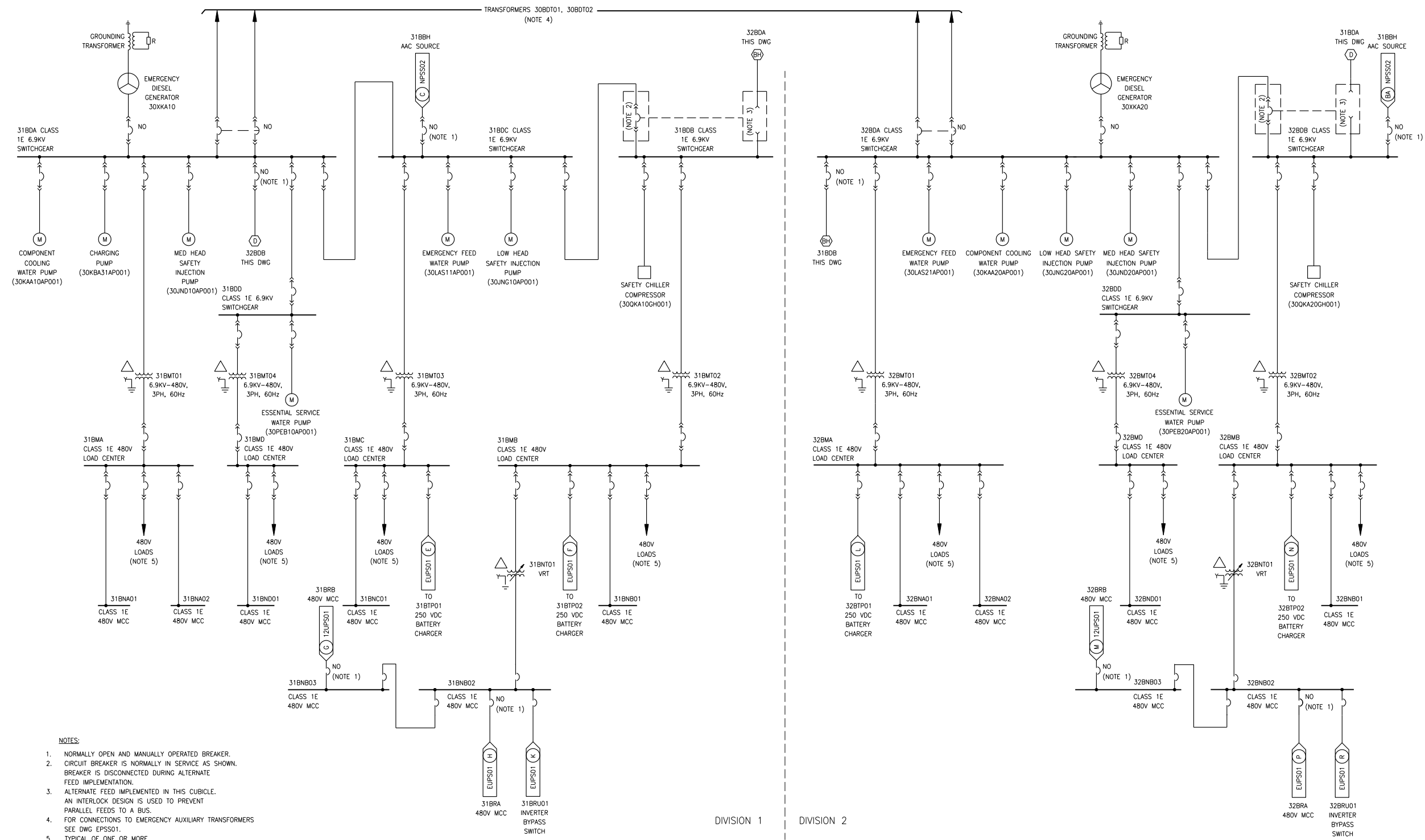

EPSS02T2

Figure 8.3-2—Emergency Power Supply System Single Line Drawing
Sheet 3 of 3

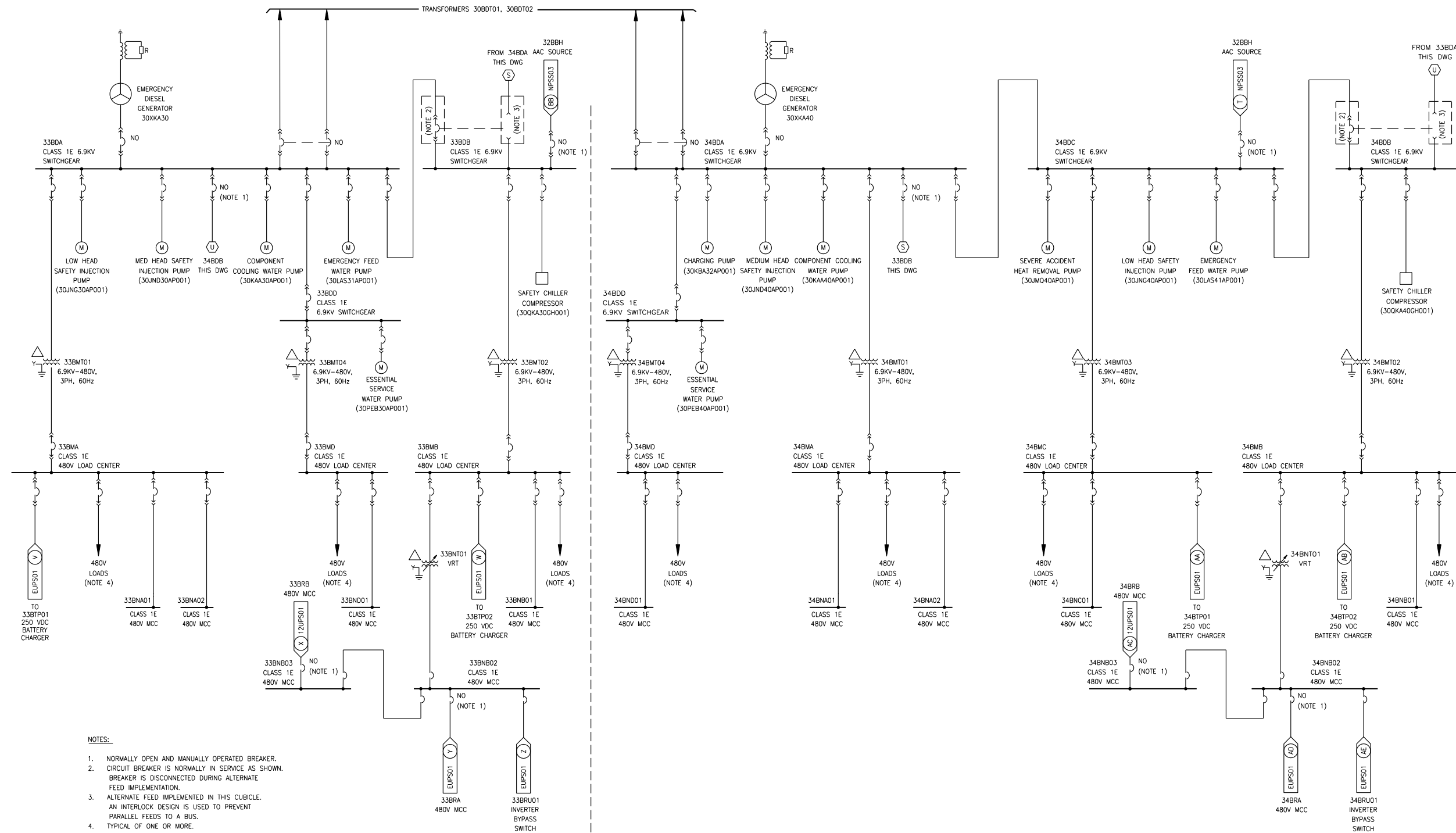

DIVISION 3
DIVISION 4

REV 001
EPSS03T2

Figure 8.3-3—Normal Power Supply System Single Line Drawing
Sheet 1 of 4

NOTES:

- 1. THE CIRCUIT BREAKERS PROVIDE SAFETY-RELATED TRIP REQUIREMENTS FOR REACTOR COOLANT PUMPS.
- 2. NORMALLY OPEN AND MANUALLY OPERATED BREAKER.

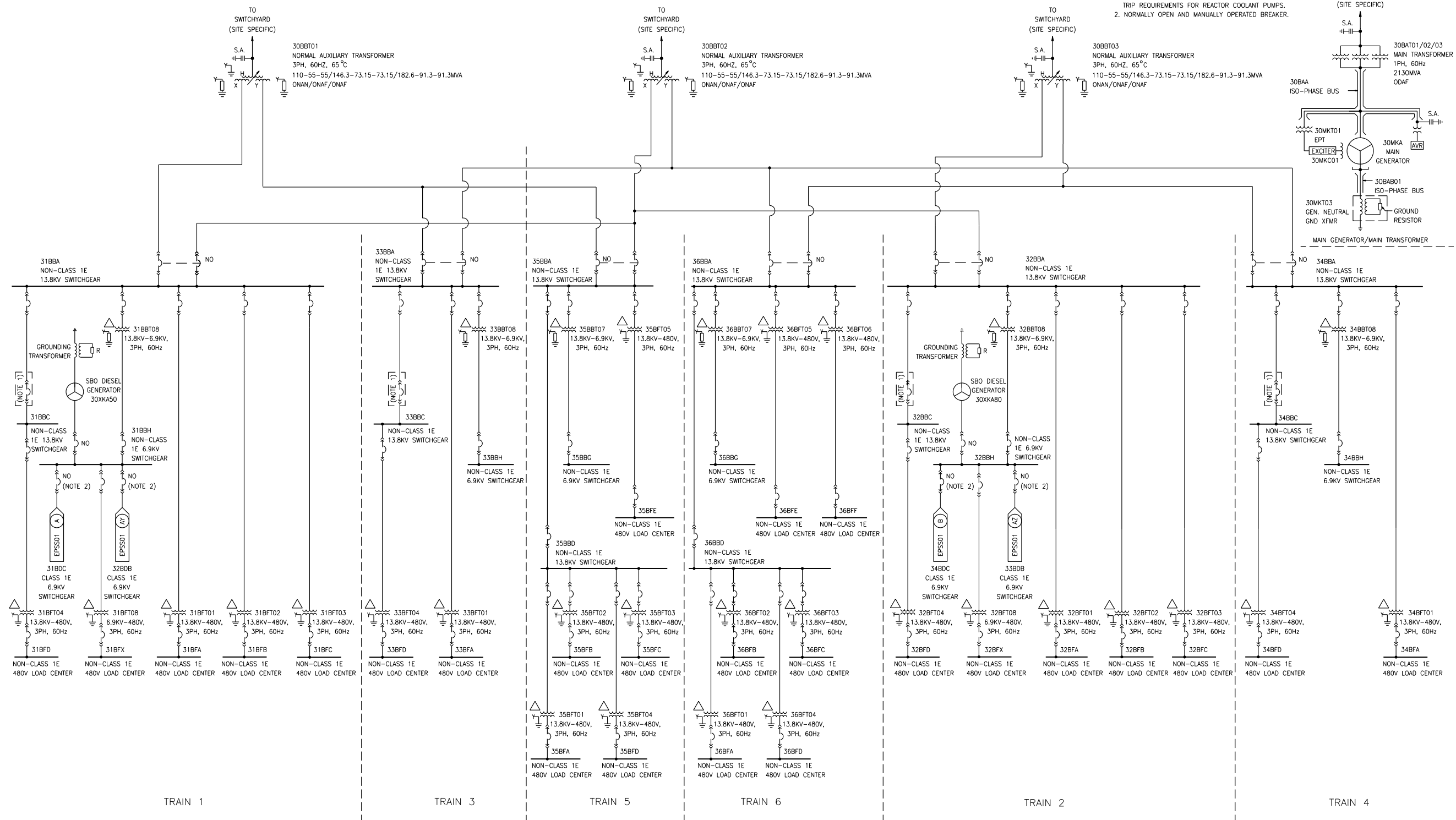

REV 001
NPSS01T2

Figure 8.3-3—Normal Power Supply System Single Line Drawing
Sheet 2 of 4

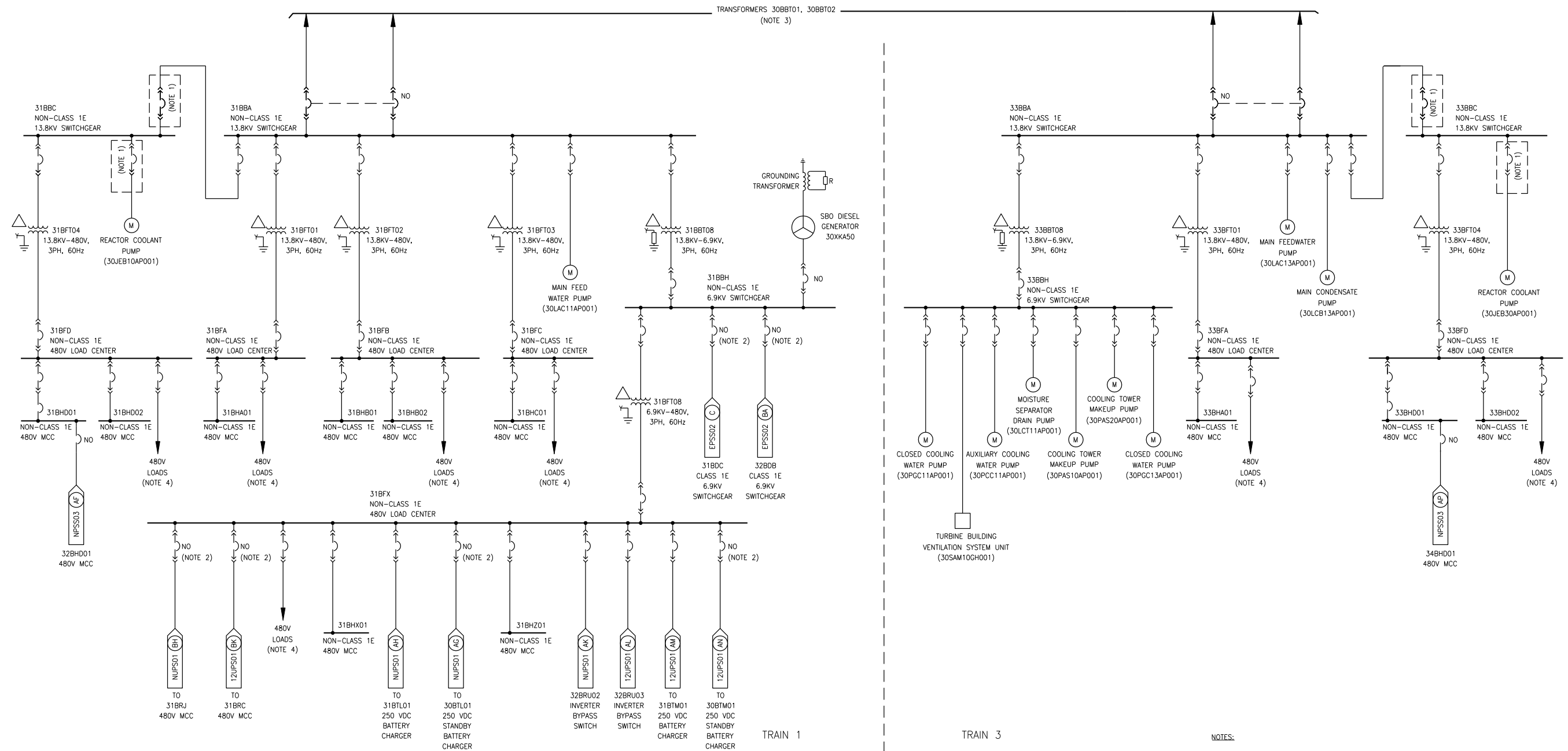

- NOTES:
1. THE CIRCUIT BREAKERS PROVIDE SAFETY-RELATED TRIP REQUIREMENTS FOR REACTOR COOLANT PUMPS.
 2. NORMALLY OPEN AND MANUALLY OPERATED BREAKER.
 3. FOR CONNECTIONS TO NORMAL AUXILIARY TRANSFORMERS SEE DWG NPSS01.
 4. TYPICAL OF ONE OR MORE.

NPSS02T2

Figure 8.3-3—Normal Power Supply System Single Line Drawing
Sheet 3 of 4

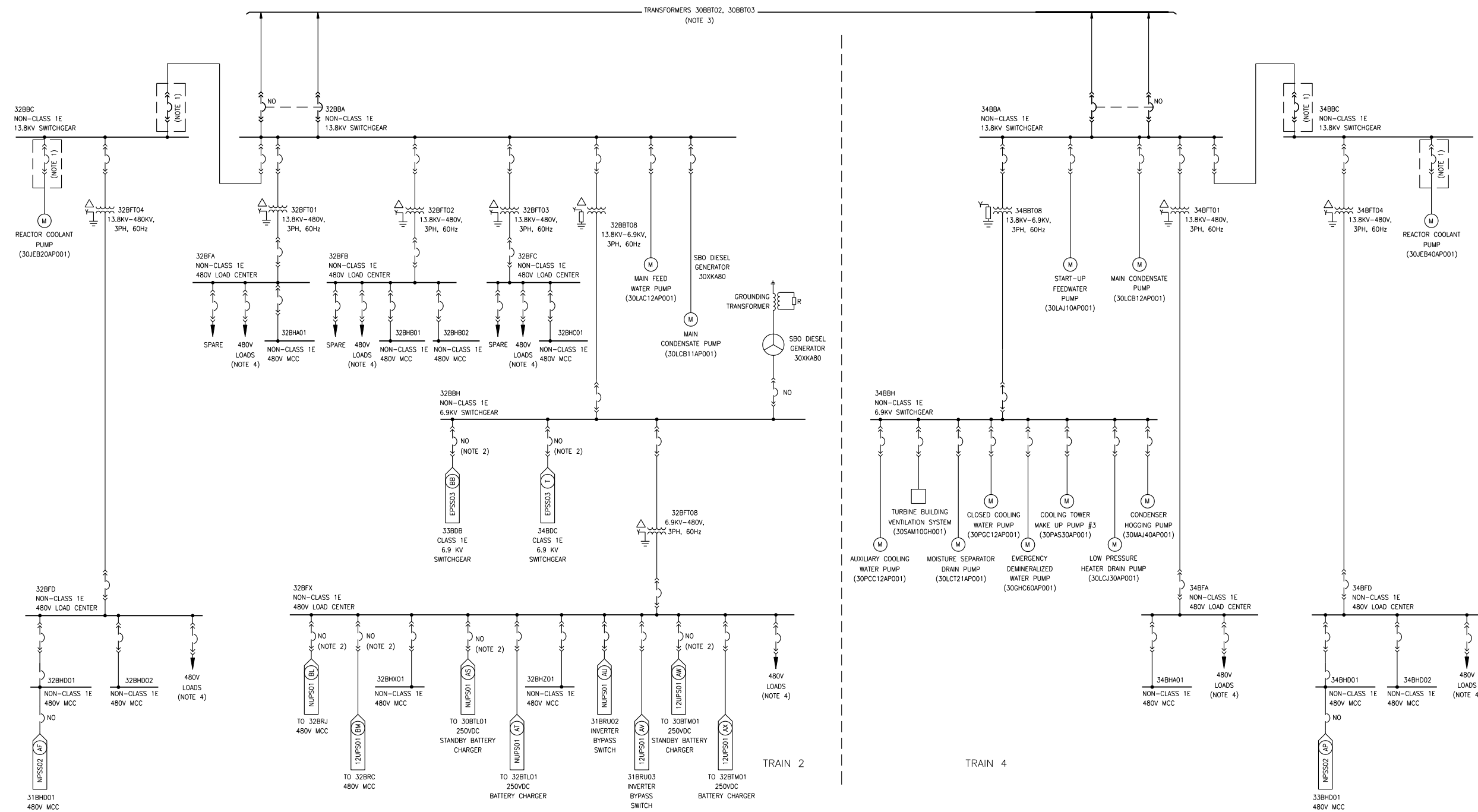

- NOTES:
1. THE CIRCUIT BREAKERS PROVIDE SAFETY-RELATED TRIP REQUIREMENTS FOR REACTOR COOLANT PUMPS.
 2. NORMALLY OPEN AND MANUALLY OPERATED BREAKER.
 3. FOR CONNECTIONS TO NORMAL AUXILIARY TRANSFORMERS SEE DWG NPSS01.
 4. TYPICAL OF ONE OR MORE.

REV 001
NPSS03T2

Figure 8.3-3—Normal Power Supply System Single Line Drawing
Sheet 4 of 4

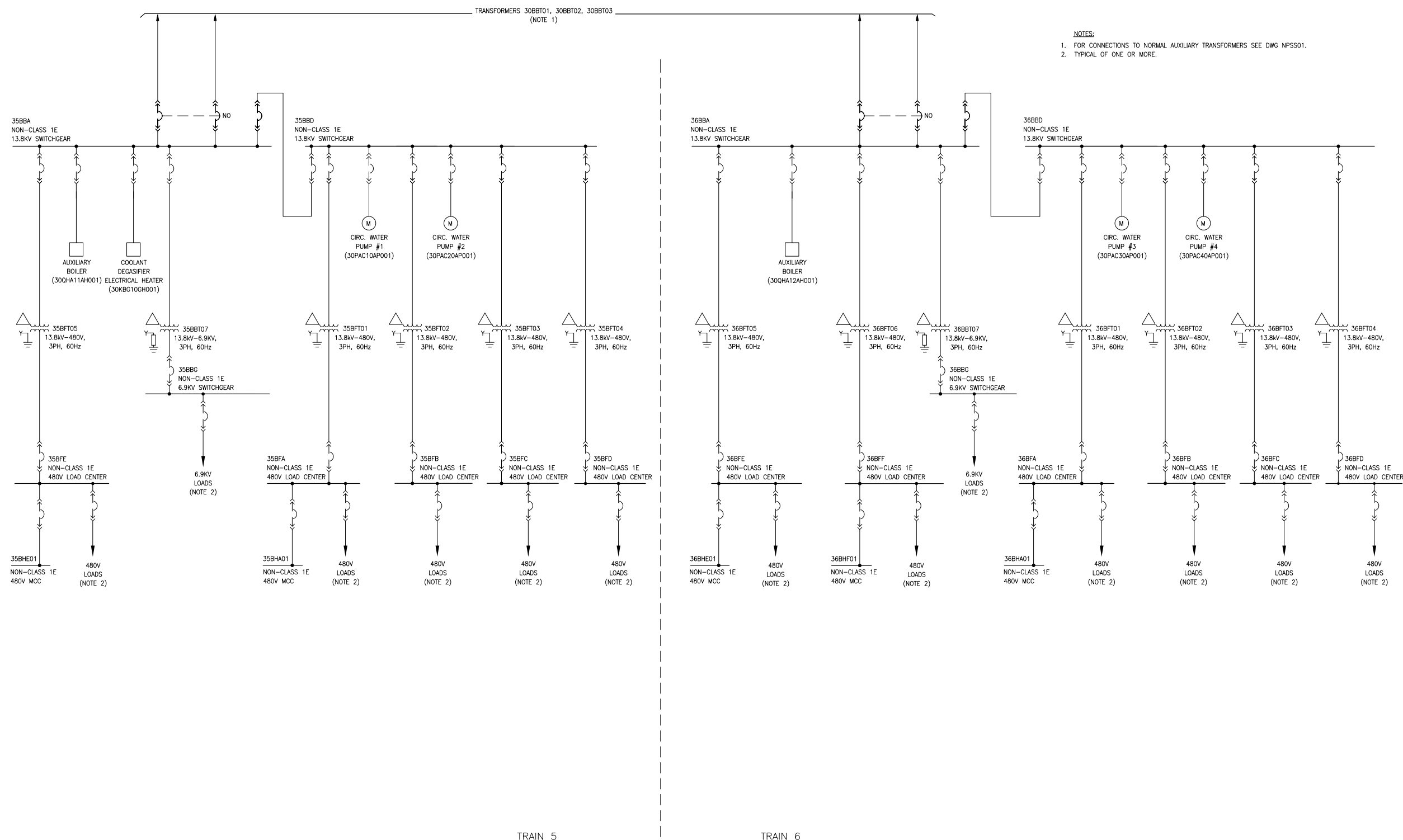

REV 001
NPSS04T2

Figure 8.3-4—[[Typical Station Grounding Grid]]

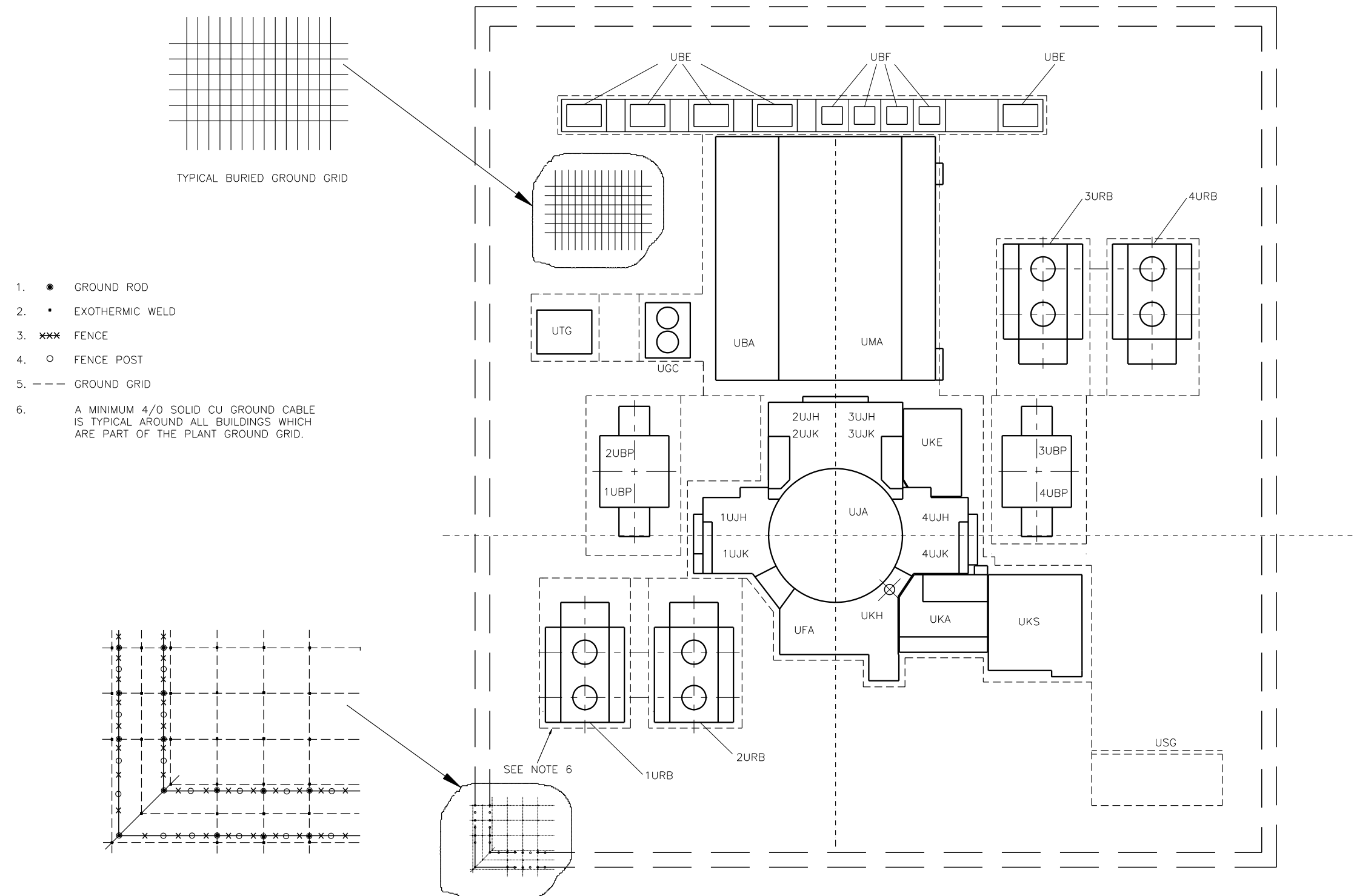

GRD01T2

Figure 8.3-6—12-Hour Uninterruptible Power Supply System Single Line Drawing

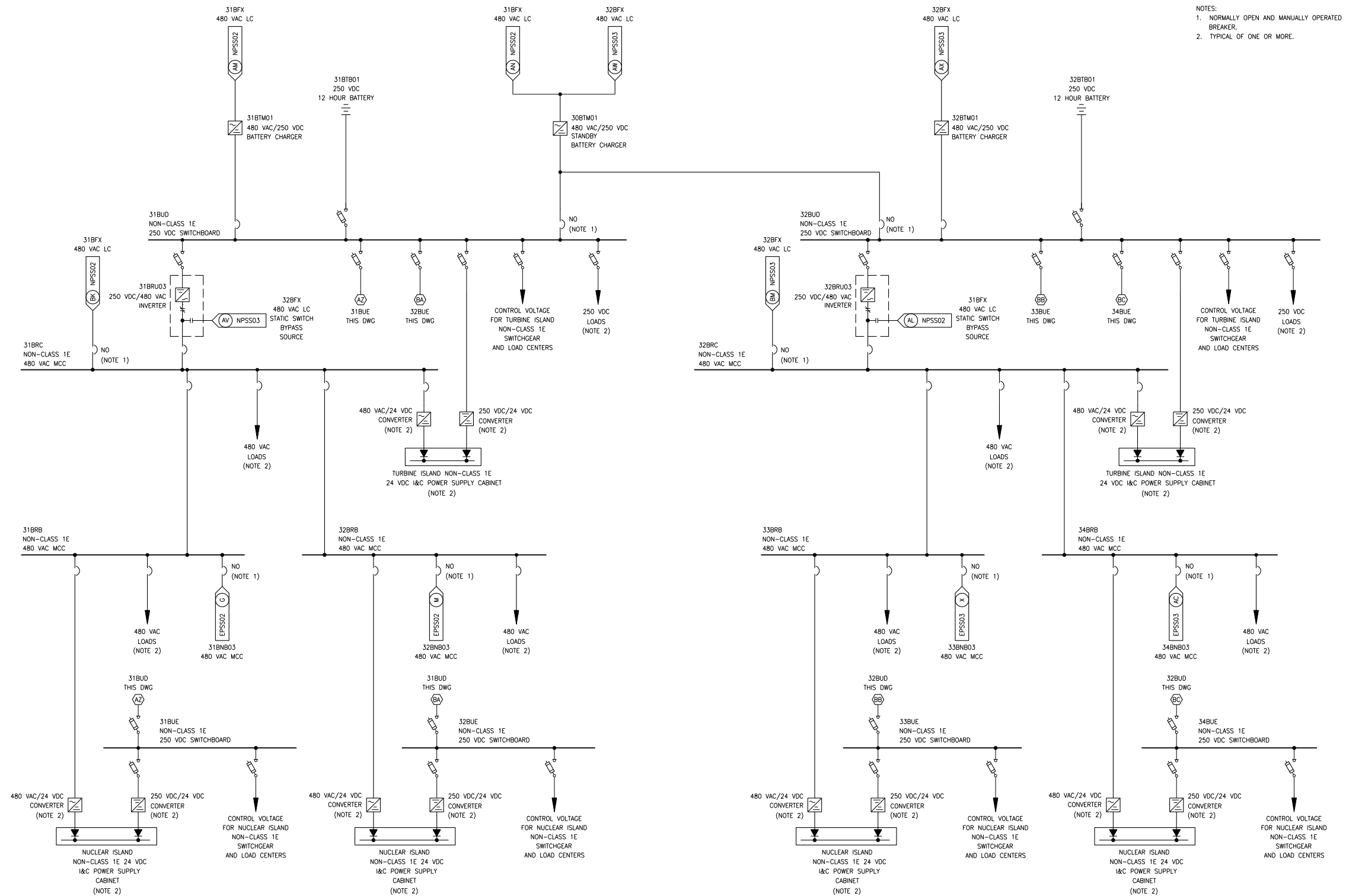

NOTES:
 1. NORMALLY OPEN AND MANUALLY OPERATED BREAKER.
 2. TYPICAL OF ONE OR MORE.

12UPS01T2

Figure 8.3-7—Non-Class 1E Uninterruptible Power Supply System Single Line Drawing

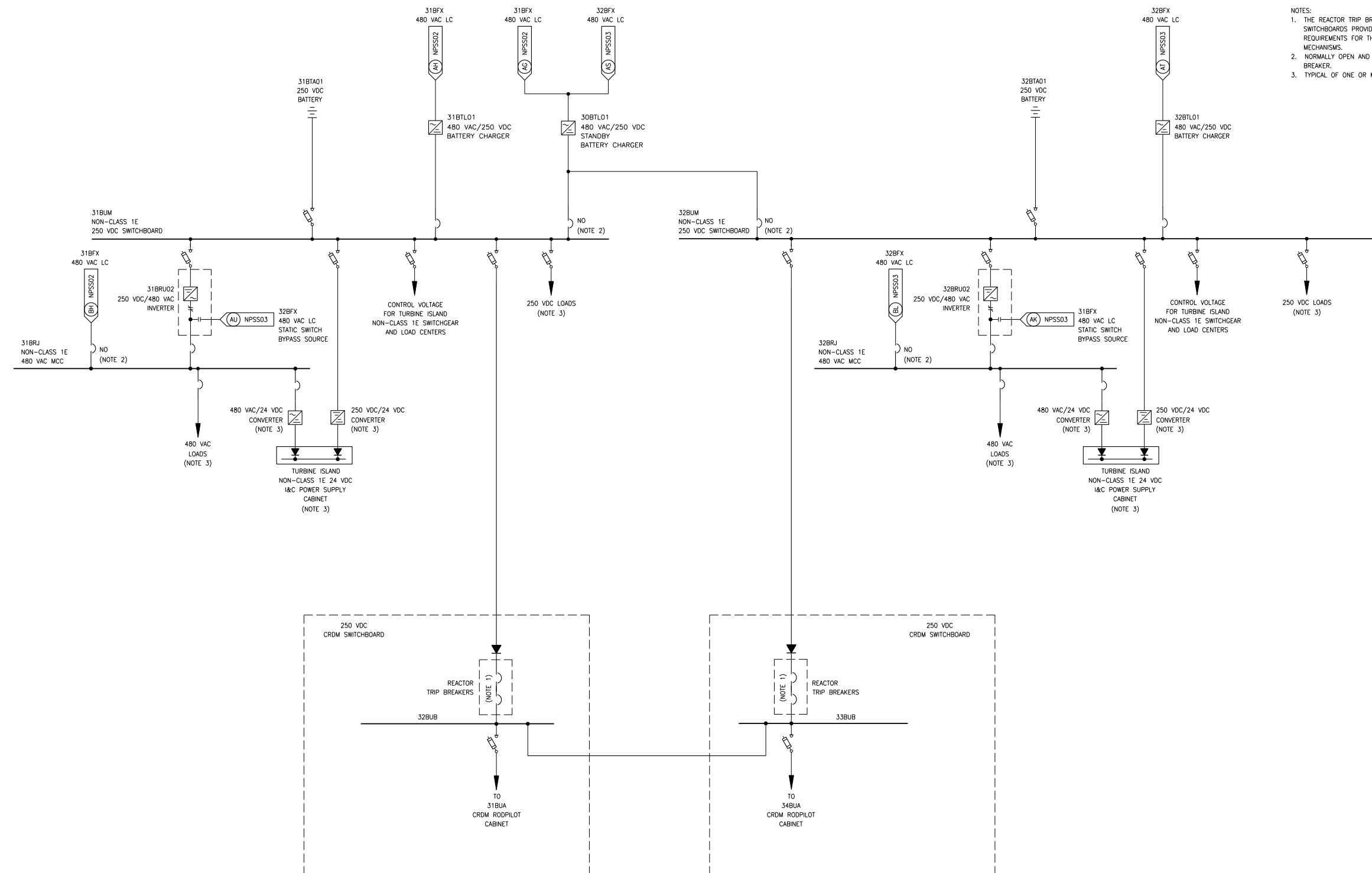

- NOTES:
1. THE REACTOR TRIP BREAKERS AND 250 VDC SWITCHBOARDS PROVIDE SAFETY-RELATED TRIP REQUIREMENTS FOR THE CONTROL ROD DRIVE MECHANISMS.
 2. NORMALLY OPEN AND MANUALLY OPERATED BREAKER.
 3. TYPICAL OF ONE OR MORE.

NUPS01T2