

Figure 2.5.10-1—Normal Power Supply System Functional Arrangement  
Sheet 1 of 4

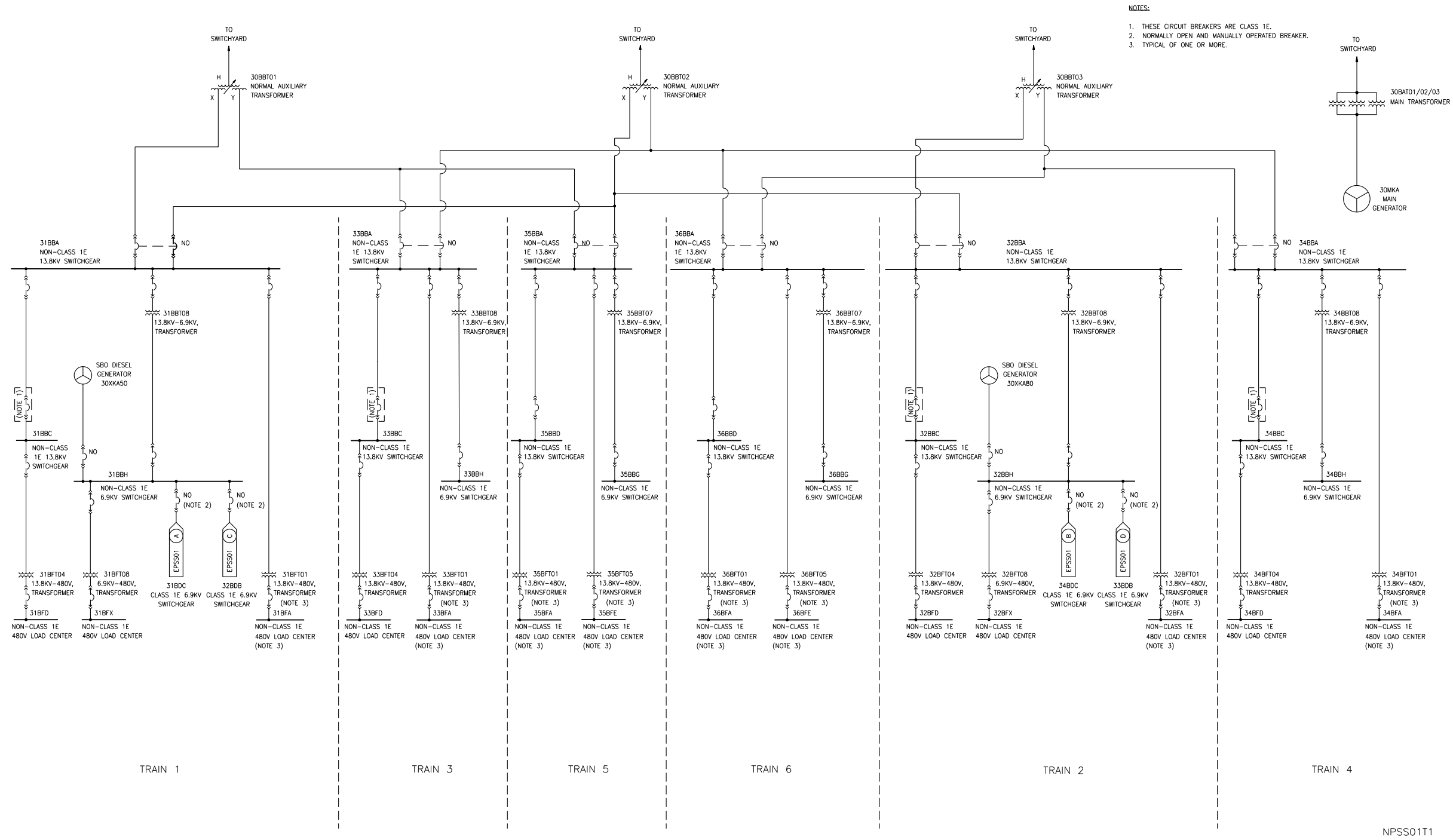

Figure 2.5.10-1—Normal Power Supply System Functional Arrangement  
Sheet 2 of 4

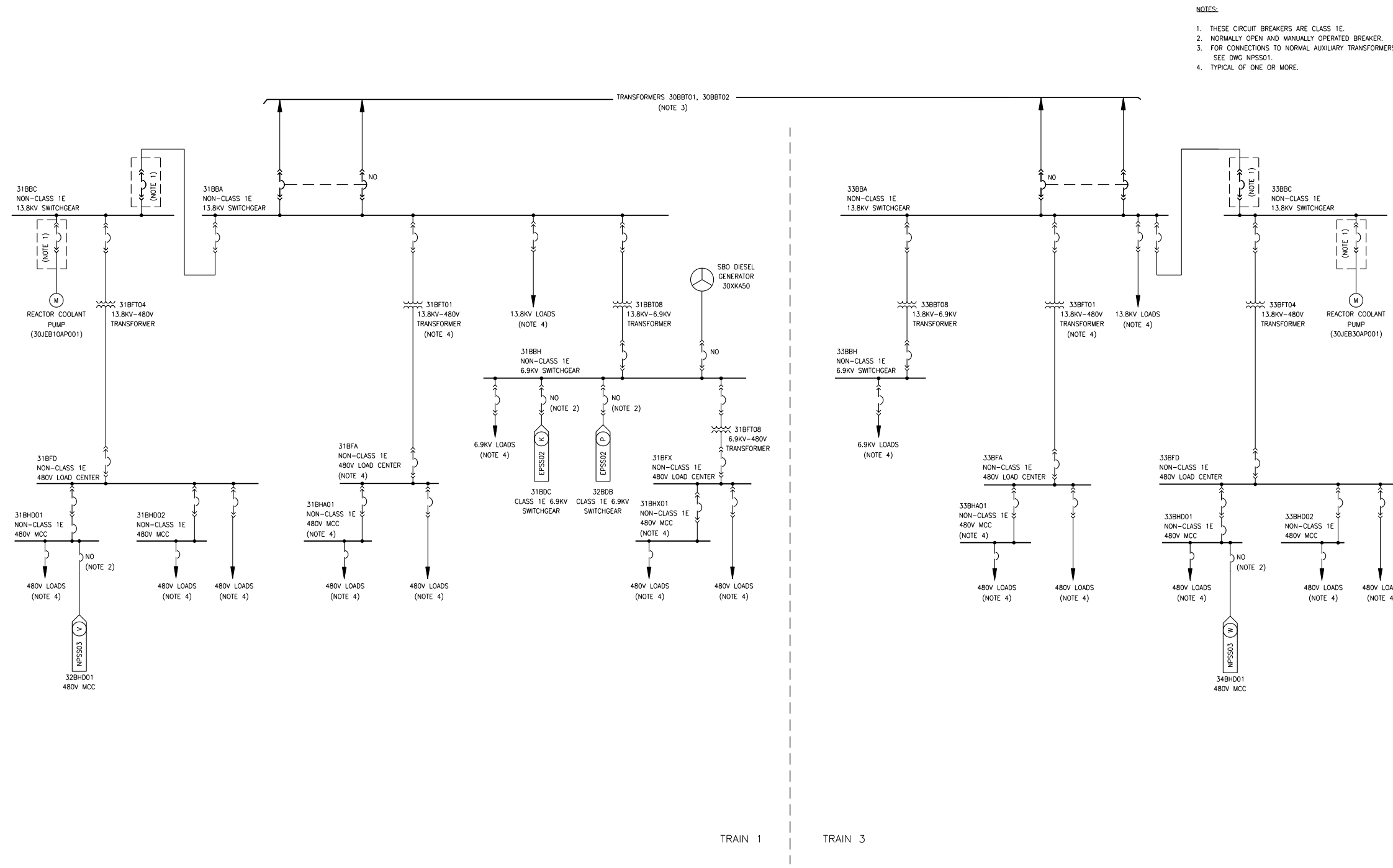
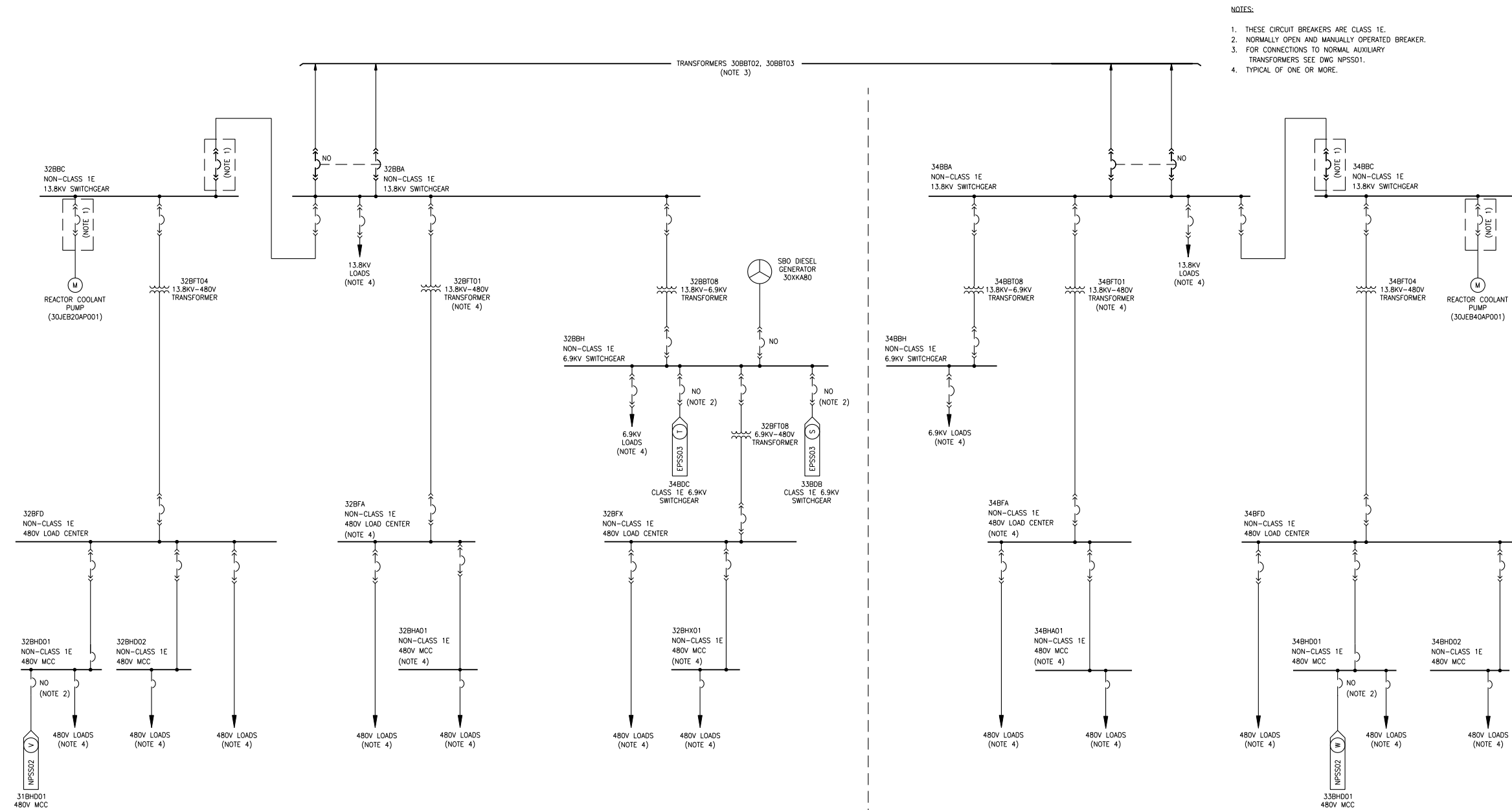

Figure 2.5.10-1—Normal Power Supply System Functional Arrangement  
Sheet 3 of 4



- NOTES:
1. THESE CIRCUIT BREAKERS ARE CLASS 1E.
  2. NORMALLY OPEN AND MANUALLY OPERATED BREAKER.
  3. FOR CONNECTIONS TO NORMAL AUXILIARY TRANSFORMERS SEE DWG NPSS01.
  4. TYPICAL OF ONE OR MORE.

TRAIN 2

TRAIN 4

NPSS03T1

Figure 2.5.10-1—Normal Power Supply System Functional Arrangement  
Sheet 4 of 4

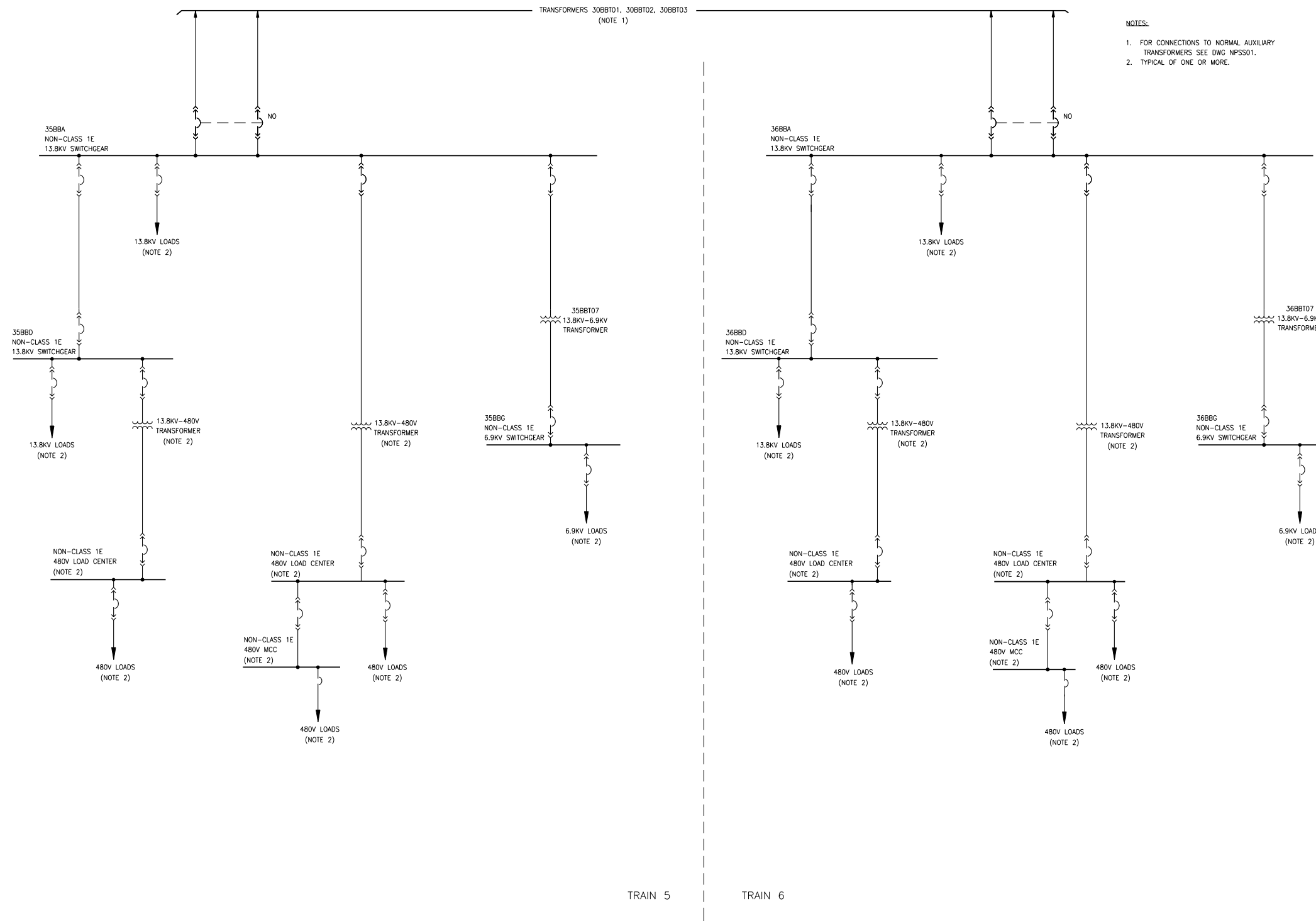

NPSS04 T1