

APPENDIX A

**TECHNICAL SPECIFICATIONS
FOR THE NAC-UMS[®] SYSTEM**

AMENDMENT 5

LIST OF EFFECTIVE PAGES

Appendix A

A-1	Amendment No. 5	A3-11	Amendment No. 5
A-2	Amendment No. 5	A3-12	Amendment No. 5
A-3	Amendment No. 5	A3-13	Amendment No. 5
A-4	Amendment No. 5	A3-14	Amendment No. 5
A1-1.....	Amendment No. 5	A3-15.....	Amendment No. 5
A1-2.....	Amendment No. 5	A3-16.....	Amendment No. 5
A1-3.....	Amendment No. 5	A3-17	Amendment No. 5
A1-4.....	Amendment No. 5	A3-18.....	Amendment No. 5
A1-5.....	Amendment No. 5	A3-19.....	Amendment No. 5
A1-6.....	Amendment No. 5	A3-20.....	Amendment No. 5
A1-7.....	Amendment No. 5	A3-21	Amendment No. 5
A1-8.....	Amendment No. 5	A3-22.....	Amendment No. 5
A1-9.....	Amendment No. 5	A4-1	Amendment No. 5
A1-10.....	Amendment No. 5	A5-1	Amendment No. 5
A1-11.....	Amendment No. 5	A5-2	Amendment No. 5
A1-12.....	Amendment No. 5	A5-3.....	Amendment No. 5
A1-13.....	Amendment No. 5	A5-4	Amendment No. 5
A1-14.....	Amendment No. 5	A5-5.....	Amendment No. 5
A1-15.....	Amendment No. 5		
A1-16.....	Amendment No. 5		
A1-17.....	Amendment No. 5		
A1-18.....	Amendment No. 5		
A1-19.....	Amendment No. 5		
A2-1.....	Amendment No. 5		
A3-1.....	Amendment No. 5		
A3-2.....	Amendment No. 5		
A3-3.....	Amendment No. 5		
A3-4.....	Amendment No. 5		
A3-5.....	Amendment No. 5		
A3-6.....	Amendment No. 5		
A3-7.....	Amendment No. 5		
A3-8.....	Amendment No. 5		
A3-9.....	Amendment No. 5		
A3-10.....	Amendment No. 5		

Table of Contents

A 1.0	USE AND APPLICATION	A1-1
A 1.1	Definitions	A1-1
A 1.2	Logical Connectors.....	A1-9
A 1.3	Completion Times	A1-12
A 1.4	Frequency	A1-17
A 2.0	[Reserved]	A2-1
A 3.0	LIMITING CONDITION FOR OPERATION (LCO) APPLICABILITY	A3-1
	SURVEILLANCE REQUIREMENT (SR) APPLICABILITY.....	A3-2
A 3.1	NAC-UMS [®] SYSTEM Integrity.....	A3-4
A 3.1.1	CANISTER Maximum Time in Vacuum Drying.....	A3-4
A 3.1.2	CANISTER Vacuum Drying Pressure	A3-7
A 3.1.3	CANISTER Helium Backfill Pressure	A3-8
A 3.1.4	CANISTER Maximum Time in TRANSFER CASK	A3-9
A 3.1.5	CANISTER Helium Leak Rate.....	A3-12
A 3.1.6	CONCRETE CASK Heat Removal System	A3-13
A 3.1.7	Deleted	A3-15
A 3.2	NAC-UMS [®] SYSTEM Radiation Protection.....	A3-16
A 3.2.1	CANISTER Surface Contamination.....	A3-16
A 3.2.2	CONCRETE CASK Average Surface Dose Rates	A3-18
A 3.3	NAC-UMS [®] SYSTEM Criticality Control.....	A3-21
A 3.3.1	Dissolved Boron Concentration.....	A3-21
Figure A3-1	CONCRETE CASK Surface Dose Rate Measurement	A-3-20
A 4.0	[Reserved]	A4-1
A 5.0	ADMINISTRATIVE CONTROLS AND PROGRAMS	A5-1
A 5.1	Training Program.....	A5-1
A 5.2	Pre-Operational Testing and Training Exercises.....	A5-1
A 5.3	Special Requirements for the First System Placed in Service.....	A5-2
A 5.4	Surveillance After an Off-Normal, Accident, or Natural Phenomena Event.....	A5-2
A 5.5	Radioactive Effluent Control Program.....	A5-3

Table of Contents (Continued)

A 5.6 NAC-UMS[®] SYSTEM Transport Evaluation ProgramA5-3
A 5.7 Deleted.....A5-4
Table A5-1 TRANSFER CASK and CONCRETE CASK Lifting RequirementsA5-5

A 1.0 USE AND APPLICATION

A 1.1 Definitions

-----NOTE-----

The defined terms of this section appear in capitalized type and are applicable throughout this section.

<u>Term</u>	<u>Definition</u>
ACTIONS	ACTIONS shall be that part of a Specification that prescribes Required Actions to be taken under designated Conditions within specified Completion Times.
ASSEMBLY DEFECT	Any change in the physical as-built condition of the assembly, with the exception of normal in-reactor changes such as elongation from irradiation growth or assembly bow. Examples of ASSEMBLY DEFECTS include: (a) missing rods, (b) broken or missing grids or grid straps (spacer), and (c) missing or broken grid springs, etc. An assembly with a defect is damaged only if it cannot meet its fuel-specific and system-related functions.
BREACHED SPENT FUEL ROD	Spent fuel with cladding defects that permit the release of gas from the interior of the fuel rod. A fuel rod breach may be a minor defect (i.e., hairline crack or pinhole), allowing the rod to be classified as undamaged, or be a gross breach requiring a damaged fuel classification.
CANISTER	See TRANSPORTABLE STORAGE CANISTER

(continued)

CANISTER HANDLING FACILITY	The CANISTER HANDLING FACILITY includes the following components and equipment: (1) a canister transfer station that allows the staging of the TRANSFER CASK with the CONCRETE CASK or transport cask to facilitate CANISTER lifts involving spent fuel handling not covered by 10 CFR 50; and (2) either a stationary lift device or mobile lifting device used to lift the TRANSFER CASK and CANISTER.
CONCRETE CASK	See VERTICAL CONCRETE CASK
CONSOLIDATED FUEL	A nonstandard fuel configuration in which the undamaged individual fuel rods from one or more fuel assemblies are placed in a single container or a lattice structure that is similar to a fuel assembly. CONSOLIDATED FUEL is stored in a MAINE YANKEE FUEL CAN.
DAMAGED FUEL	<p>Spent nuclear fuel (SNF) that cannot fulfill its fuel-specific or system-related function. DAMAGED FUEL must be placed in a MAINE YANKEE FUEL CAN unless otherwise noted. Spent fuel is classified as damaged under the following conditions.</p> <ol style="list-style-type: none">1. There is visible deformation of the rods in the SNF assembly. <p>Note: This is not referring to the uniform bowing that occurs in the reactor; this refers to bowing that significantly opens up the lattice spacing.</p>2. Individual fuel rods are missing from the assembly and the missing rods are not replaced by solid dummy/filler rods that displace a volume equal to, or greater than, the original fuel rods. <p>Note: Maine Yankee fuel assemblies with missing rods, not replaced by solid dummy/filler rods, are an exception based upon the criticality analysis done for these assemblies. They are, therefore, considered to be undamaged. However, these Maine Yankee assemblies must be preferentially loaded per Tables B2-6 and B2-7.</p>

(continued)

DAMAGED FUEL (cont'd)

3. The SNF assembly has missing, displaced or damaged structural components such that either:

- Radiological and/or criticality safety is adversely affected (e.g., significantly changed rod pitch); or
- The assembly cannot be handled by normal means (i.e., crane and grapple).

Note: PWR assemblies with the following structural defects meet UMS system-related functional requirements and are, therefore, classified as undamaged.

- Grid, grid strap, and/or grid strap spring damage in PWR assemblies such that the unsupported length of the fuel rod does not exceed 60 inches.

4. Any SNF assembly that contains fuel rods for which reactor operating records (or other records or tests) cannot support the conclusion that they do not contain gross breaches.

Note: Breached fuel rods with minor cladding defects (i.e, pinhole leaks or hairline cracks that will not permit significant release of particulate matter from the spent fuel rod) meet UMS system-related functional requirements and are, therefore, classified as undamaged.

5. The SNF assembly is no longer in the form of an intact fuel bundle (e.g., consists of or contains debris such as loose fuel pellets or rod segments).

FUEL DEBRIS

An intact or a partial fuel rod or an individual intact or partial fuel pellet not contained in a fuel rod. Fuel debris is inserted into a 9 × 9 array of tubes in a lattice that has approximately the same dimensions as a standard fuel assembly. FUEL DEBRIS is stored in a MAINE YANKEE FUEL CAN.

(continued)

GROSSLY BREACHED SPENT FUEL ROD	A breach in the spent fuel cladding that is larger than a pinhole or hairline crack. A gross cladding breach may be established by visual examination with the capability to determine if the fuel pellet can be seen through the cladding, or through a review of reactor operating records indicating the presence of heavy metal isotopes.
HIGH BURNUP FUEL	A fuel assembly meeting the definition of a standard fuel assembly with an assembly average burnup between 45,000 and 60,000 MWd/MTU. Maximum peak average rod burnup is limited to 62,500 MWd/MTU.
INDEPENDENT SPENT FUEL STORAGE INSTALLATION (ISFSI)	The facility within the perimeter fence licensed for storage of spent fuel within NAC-UMS [®] SYSTEMs (see also 10 CFR 72.3).
INITIAL PEAK PLANAR-AVERAGE ENRICHMENT	THE INITIAL PEAK PLANAR-AVERAGE ENRICHMENT is the maximum planar-average enrichment at any height along the axis of the fuel assembly. The 4.7 wt % ²³⁵ U enrichment limit for BWR fuel applies along the full axial extent of the assembly. The INITIAL PEAK PLANAR-AVERAGE ENRICHMENT may be higher than the bundle (assembly) average enrichment.
INTACT FUEL (ASSEMBLY OR ROD)	Any fuel that can fulfill all fuel-specific and system-related functions and that is not breached.
LOADING OPERATIONS	LOADING OPERATIONS include all licensed activities on a NAC-UMS [®] SYSTEM while it is being loaded with fuel assemblies. LOADING OPERATIONS begin when the first fuel assembly is placed in the CANISTER and end when the NAC-UMS [®] SYSTEM is secured on the transporter. LOADING OPERATIONS does not include post-storage operations, i.e., CANISTER transfer operations between the TRANSFER CASK and the CONCRETE CASK or transport cask after STORAGE OPERATIONS.

(continued)

MAINE YANKEE FUEL CAN	A specially designed stainless steel screened can sized to hold UNDAMAGED FUEL, CONSOLIDATED FUEL, DAMAGED FUEL or FUEL DEBRIS. The screens preclude the release of gross particulate from the can into the canister cavity. The MAINE YANKEE FUEL CAN may only be loaded in a Class 1 canister.
NAC-UMS [®] SYSTEM	NAC-UMS [®] SYSTEM includes the components approved for loading and storage of spent fuel assemblies at the ISFSI. The NAC-UMS [®] SYSTEM consists of a CONCRETE CASK, a TRANSFER CASK, and a CANISTER.
OPERABLE	An OPERABLE CONCRETE CASK heat removal system transfers sufficient heat away from the fuel assemblies such that the fuel cladding and CANISTER component temperatures do not exceed applicable limits. The CONCRETE CASK heat removal system is considered OPERABLE if the difference between the ISFSI ambient temperature and the average outlet air temperature is $\leq 102^{\circ}\text{F}$ for the PWR canister or $\leq 92^{\circ}\text{F}$ for the BWR canister, or if all four air inlet and outlet screens are visually verified to be unobstructed. Failing this, a CONCRETE CASK heat removal system may be declared OPERABLE if an engineering evaluation determines the CONCRETE CASK has adequate heat transfer capabilities to assure continued spent fuel and CANISTER integrity.

(continued)

SITE SPECIFIC FUEL

Spent fuel configurations that are unique to a site or reactor due to the addition of other components or reconfiguration of the fuel assembly at the site. It includes fuel assemblies, which hold nonfuel-bearing components, such as a control element assembly, a burnable poison rod insert, a solid stainless steel rod insert, an in-core instrument thimble or a flow mixer, or which are modified as required by expediency in reactor operations, research and development or testing. Modification may consist of individual fuel rod removal, fuel rod replacement of similar or dissimilar material or enrichment, the installation, removal or replacement of burnable poison rods or solid stainless steel rods, or containerizing damaged fuel.

Site specific fuel includes irradiated fuel assemblies designed with variable enrichments and/or axial blankets, fuel that is consolidated and fuel that exceeds design basis fuel parameters.

STANDARD FUEL

Irradiated fuel assemblies having the same configuration as when originally fabricated consisting generally of the end fittings, fuel rods, guide tubes, and integral hardware. For PWR fuel, a flow mixer, an in-core instrument thimble or a burnable poison rod insert is considered to be a component of standard fuel. For BWR fuel, the channel is considered to be integral hardware. The design basis fuel characteristics and analysis are based on the STANDARD FUEL configuration.

STORAGE OPERATIONS

STORAGE OPERATIONS include all licensed activities that are performed at the ISFSI, while an NAC-UMS[®] SYSTEM containing spent fuel is located on the storage pad within the ISFSI perimeter.

TRANSFER CASK

TRANSFER CASK is a shielded lifting device that holds the CANISTER during LOADING and UNLOADING OPERATIONS and during closure welding, vacuum drying, leak testing, and non-destructive examination of the CANISTER closure welds. The TRANSFER CASK is also used to transfer the CANISTER into and from the CONCRETE CASK and into the transport cask. TRANSFER CASK refers to either the standard or advanced transfer cask.

TRANSFER OPERATIONS

TRANSFER OPERATIONS include all licensed activities involved in transferring a loaded CANISTER from a CONCRETE CASK to another CONCRETE CASK or to a TRANSPORT CASK.

TRANSPORT OPERATIONS

TRANSPORT OPERATIONS include all licensed activities involved in moving a loaded NAC-UMS® CONCRETE CASK and CANISTER to and from the ISFSI. TRANSPORT OPERATIONS begin when the NAC-UMS® SYSTEM is first secured on the transporter and end when the NAC-UMS® SYSTEM is at its destination and no longer secured on the transporter.

TRANSPORTABLE STORAGE
CANISTER (CANISTER)

TRANSPORTABLE STORAGE CANISTER is the sealed container that consists of a tube and disk fuel basket in a cylindrical canister shell that is welded to a baseplate, shield lid with welded port covers, and structural lid. The CANISTER provides the confinement boundary for the confined spent fuel.

UNDAMAGED FUEL

Spent nuclear fuel that can meet all fuel specific and system-related functions. UNDAMAGED FUEL is spent nuclear fuel that is not DAMAGED FUEL and does not contain assembly structural defects that adversely affect radiological and/or criticality safety. As such, UNDAMAGED FUEL may contain:

- a) BREACHED SPENT FUEL RODS (i.e, rods with minor defects up to hairline cracks or pinholes) but can not contain grossly breached fuel rods;
- b) Grid, grid strap, and/or grid spring damage in PWR assemblies, provided that the unsupported length of the fuel rod does not exceed 60 inches.

(continued)

UNLOADING OPERATIONS

UNLOADING OPERATIONS include all licensed activities on a NAC-UMS[®] SYSTEM to be unloaded of the contained fuel assemblies. UNLOADING OPERATIONS begin when the NAC-UMS[®] SYSTEM is no longer secured on the transporter and end when the last fuel assembly is removed from the NAC-UMS[®] SYSTEM.

VERTICAL CONCRETE CASK
(CONCRETE CASK)

VERTICAL CONCRETE CASK is the cask that receives and holds the sealed CANISTER. It provides the gamma and neutron shielding and convective cooling of the spent fuel confined in the CANISTER.

A 1.0 USE AND APPLICATION

A 1.2 Logical Connectors

PURPOSE The purpose of this section is to explain the meaning of logical connectors.

Logical connectors are used in Technical Specifications (TS) to discriminate between, and yet connect, discrete Conditions, Required Actions, Completion Times, Surveillances, and Frequencies. The only logical connectors that appear in Technical Specifications are "AND" and "OR." The physical arrangement of these connectors constitutes logical conventions with specific meanings.

BACKGROUND Several levels of logic may be used to state Required Actions. These levels are identified by the placement (or nesting) of the logical connectors and by the number assigned to each Required Action. The first level of logic is identified by the first digit of the number assigned to a Required Action and the placement of the logical connector in the first level of nesting (i.e., left justified with the number of the Required Action). The successive levels of logic are identified by additional digits of the Required Action number and by successive indentations of the logical connectors.

When logical connectors are used to state a Condition, Completion Time, Surveillance, or Frequency, only the first level of logic is used; the logical connector is left justified with the statement of the Condition, Completion Time, Surveillance, or Frequency.

(continued)

EXAMPLES The following examples illustrate the use of logical connectors.

EXAMPLES EXAMPLE 1.2-1
ACTIONS

CONDITION	REQUIRED ACTION	COMPLETION TIME
A. LCO not met	A.1 Verify. . . <u>AND</u> A.2 Restore. . .	

In this example, the logical connector “AND” is used to indicate that when in Condition A, both Required Actions A.1 and A.2 must be completed.

(continued)

EXAMPLES
(continued)

EXAMPLE 1.2-2

ACTIONS

CONDITION	REQUIRED ACTION	COMPLETION TIME
A. LCO not met	A.1 Stop. . .	
	<u>OR</u>	
	A.2.1 Verify. . .	
	<u>AND</u>	
	A.2.2	
	A.2.2.1 Reduce. . .	
	<u>OR</u>	
	A.2.2.2 Perform. . .	
	<u>OR</u>	
	A.3 Remove. . .	

This example represents a more complicated use of logical connectors. Required Actions A.1, A.2, and A.3 are alternative choices, only one of which must be performed as indicated by the use of the logical connector "OR" and the left justified placement. Any one of these three Actions may be chosen. If A.2 is chosen, then both A.2.1 and A.2.2 must be performed as indicated by the logical connector "AND." Required Action A.2.2 is met by performing A.2.2.1 or A.2.2.2. The indented position of the logical connector "OR" indicated that A.2.2.1 and A.2.2.2 are alternative choices, only one of which must be performed.

A 1.0 USE AND APPLICATION

A 1.3 Completion Times

PURPOSE The purpose of this section is to establish the Completion Time convention and to provide guidance for its use.

BACKGROUND Limiting Conditions for Operations (LCOs) specify the lowest functional capability or performance levels of equipment required for safe operation of the NAC-UMS[®] SYSTEM. The ACTIONS associated with an LCO state conditions that typically describe the ways in which the requirements of the LCO can fail to be met. Specified with each stated Condition are Required Action(s) and Completion Time(s).

DESCRIPTION The Completion Time is the amount of time allowed for completing a Required Action. It is referenced to the time of discovery of a situation (e.g., equipment or variable not within limits) that requires entering an ACTIONS Condition, unless otherwise specified, provided that the NAC-UMS[®] SYSTEM is in a specified Condition stated in the Applicability of the LCO. Prior to the expiration of the specified Completion Time, Required Actions must be completed. An ACTIONS Condition remains in effect and the Required Actions apply until the Condition no longer exists or the NAC-UMS[®] SYSTEM is not within the LCO Applicability.

Once a Condition has been entered, subsequent subsystems, components, or variables expressed in the Condition, discovered to be not within limits, will not result in separate entry into the Condition, unless specifically stated. The Required Actions of the Condition continue to apply to each additional failure, with Completion Times based on initial entry into the Condition.

(continued)

EXAMPLES The following examples illustrate the use of Completion Times with different types of Conditions and changing Conditions.

EXAMPLE 1.3-1

ACTIONS

CONDITION	REQUIRED ACTION	COMPLETION TIME
B. Required Action and associated Completion Time not met	B.1 Perform Action B.1	12 hours
	<u>AND</u>	
	B.2 Perform Action B.2	36 hours

Condition B has two Required Actions. Each Required Action has its own Completion Time. Each Completion Time is referenced to the time that Condition B is entered.

The Required Actions of Condition B are to complete action B.1 within 12 hours AND complete action B.2 within 36 hours. A total of 12 hours is allowed for completing action B.1 and a total of 36 hours (not 48 hours) is allowed for completing action B.2 from the time that Condition B was entered. If action B.1 is completed within six hours, the time allowed for completing action B.2 is the next 30 hours because the total time allowed for completing action B.2 is 36 hours.

(continued)

EXAMPLES
(continued)

EXAMPLE 1.3-2

ACTIONS

CONDITION	REQUIRED ACTION	COMPLETION TIME
A. One System not within limit	A.1 Restore System to within limit	7 days
B. Required Action and associated Completion Time not met	B.1 Complete action B.1	12 hours
	<u>AND</u> B.2 Complete action B.2	36 hours

When a System is determined not to meet the LCO, Condition A is entered. If the System is not restored within seven days, Condition B is also entered, and the Completion Time clocks for Required Actions B.1 and B.2 start. If the System is restored after Condition B is entered, Conditions A and B are exited; therefore, the Required Actions of Condition B may be terminated.

(continued)

EXAMPLES
(continued)

EXAMPLE 1.3-3

ACTIONS

-----NOTE-----
Separate Condition entry is allowed for each component.

CONDITION	REQUIRED ACTION	COMPLETION TIME
A. LCO not met	A.1 Restore compliance with LCO	4 hours
B. Required Action and associated Completion Time not met	B.1 Complete action B.1	6 hours
	<u>AND</u>	
	B.2 Complete action B.2	12 hours

The Note above the ACTIONS table is a method of modifying how the Completion Time is tracked. If this method of modifying how the Completion Time is tracked was applicable only to a specific Condition, the Note would appear in that Condition rather than at the top of the ACTIONS Table.

The Note allows Condition A to be entered separately for each component, and Completion Times to be tracked on a per component basis. When a component is determined to not meet the LCO, Condition A is entered and its Completion Time starts. If subsequent components are determined to not meet the LCO, Condition A is entered for each component and separate Completion Times are tracked for each component.

(continued)

EXAMPLES
(continued)

EXAMPLE 1.3-3

IMMEDIATE
COMPLETION
TIME

When “Immediately” is used as a Completion Time, the Required Action should be pursued without delay and in a controlled manner.

A 1.0 USE AND APPLICATION

A 1.4 Frequency

PURPOSE The purpose of this section is to define the proper use and application of Frequency requirements.

DESCRIPTION Each Surveillance Requirement (SR) has a specified Frequency in which the Surveillance must be met in order to meet the associated Limiting Condition for Operation (LCO). An understanding of the correct application of the specified Frequency is necessary for compliance with the SR.

Each “specified Frequency” is referred to throughout this section and each of the Specifications of Section 3.0, Surveillance Requirement (SR) Applicability. The “specified Frequency” consists of requirements of the Frequency column of each SR.

Situations where a Surveillance could be required (i.e., its Frequency could expire), but where it is not possible or not desired that it be performed until sometime after the associated LCO is within its Applicability, represent potential SR 3.0.4 conflicts. To avoid these conflicts, the SR (i.e., the Surveillance or the Frequency) is stated such that it is only “required” when it can be and should be performed. With an SR satisfied, SR 3.0.4 imposes no restriction.

The use of “met” or “performed” in these instances conveys specific meanings. A Surveillance is “met” only after the acceptance criteria are satisfied. Known failure of the requirements of a Surveillance, even without a Surveillance specifically being “performed,” constitutes a Surveillance not “met.”

(continued)

EXAMPLES The following examples illustrate the various ways that Frequencies are specified.

EXAMPLE 1.4-1

SURVEILLANCE REQUIREMENTS

SURVEILLANCE	FREQUENCY
Verify pressure within limit	12 hours

Example 1.4-1 contains the type of SR most often encountered in the Technical Specifications (TS). The Frequency specifies an interval (12 hours) during which the associated Surveillance must be performed at least one time. Performance of the Surveillance initiates the subsequent interval. Although the Frequency is stated as 12 hours, SR 3.0.2 allows an extension of the time interval to 1.25 times the interval specified in the Frequency for operational flexibility. The measurement of this interval continues at all times, even when the SR is not required to be met per SR 3.0.1 (such as when the equipment or variables are outside specified limits, or the facility is outside the Applicability of the LCO). If the interval specified by SR 3.0.2 is exceeded while the facility is in a condition specified in the Applicability of the LCO, the LCO is not met in accordance with SR 3.0.1.

If the interval as specified by SR 3.0.2 is exceeded while the facility is not in a condition specified in the Applicability of the LCO for which performance of the SR is required, the Surveillance must be performed within the Frequency requirements of SR 3.0.2, prior to entry into the specified condition. Failure to do so would result in a violation of SR 3.0.4.

(continued)

EXAMPLE 1.4-2

SURVEILLANCE REQUIREMENTS

SURVEILLANCE	FREQUENCY
Verify flow is within limits	Once within 12 hours prior to starting activity <u>AND</u> 24 hours thereafter

Example 1.4-2 has two Frequencies. The first is a one time performance Frequency, and the second is of the type shown in Example 1.4-1. The logical connector “AND” indicates that both Frequency requirements must be met. Each time the example activity is to be performed, the Surveillance must be performed within 12 hours prior to starting the activity.

The use of “once” indicates a single performance will satisfy the specified Frequency (assuming no other Frequencies are connected by “AND”). This type of Frequency does not qualify for the 25% extension allowed by SR 3.0.2.

“Thereafter” indicates future performances must be established per SR 3.0.2, but only after a specified condition is first met (i.e., the “once” performance in this example). If the specified activity is canceled or not performed, the measurement of both intervals stops. New intervals start upon preparing to restart the specified activity.

A 2.0 [Reserved]

A 3.0 LIMITING CONDITION FOR OPERATION (LCO) APPLICABILITY

LCO 3.0.1 LCOs shall be met during specified conditions in the Applicability, except as provided in LCO 3.0.2.

LCO 3.0.2 Upon failure to meet an LCO, the Required Actions of the associated Conditions shall be met, except as provided in LCO 3.0.5.

If the LCO is met or is no longer applicable prior to expiration of the specified Completion Time(s), completion of the Required Action(s) is not required, unless otherwise stated.

LCO 3.0.3 Not applicable to a NAC-UMS[®] SYSTEM.

LCO 3.0.4 When an LCO is not met, entry into a specified condition in the Applicability shall not be made except when the associated ACTIONS to be entered permit continued operation in the specified condition in the Applicability for an unlimited period of time. This Specification shall not prevent changes in specified conditions in the Applicability that are required to comply with ACTIONS or that are related to the unloading of an NAC-UMS[®] SYSTEM.

Exceptions to this Condition are stated in the individual Specifications. These exceptions allow entry into specified conditions in the Applicability where the associated ACTIONS to be entered allow operation in the specified conditions in the Applicability only for a limited period of time.

LCO 3.0.5 Equipment removed from service or not in service in compliance with ACTIONS may be returned to service under administrative control solely to perform testing required to demonstrate it meets the LCO or that other equipment meets the LCO. This is an exception to LCO 3.0.2 for the System to return to service under administrative control to perform the testing.

A 3.0 SURVEILLANCE REQUIREMENT (SR) APPLICABILITY

SR 3.0.1 SRs shall be met during the specified conditions in the Applicability for individual LCOs, unless otherwise stated in the SR. Failure to meet a Surveillance, whether such failure is experienced during the performance of the Surveillance or between performances of the Surveillance, shall be a failure to meet the LCO. Failure to perform a Surveillance within the specified Frequency shall be a failure to meet the LCO, except as provided in SR 3.0.3. Surveillances do not have to be performed on equipment or variables outside specified limits.

SR 3.0.2 The specified Frequency for each SR is met if the Surveillance is performed within 1.25 times the interval specified in the Frequency, as measured from the previous performance or as measured from the time a specified condition of the Frequency is met.

For Frequencies specified as “once,” the above interval extension does not apply. If a Completion Time requires periodic performance on a “once per...” basis, the above Frequency extension applies to each performance after the initial performance.

Exceptions to this Specification are stated in the individual Specifications.

SR 3.0.3 If it is discovered that a Surveillance was not performed within its specified Frequency, then compliance with the requirement to declare the LCO not met may be delayed from the time of discovery up to 24 hours or up to the limit of the specified Frequency, whichever is less. This delay period is permitted to allow performance of the Surveillance.

If the Surveillance is not performed within the delay period, the LCO must immediately be declared not met, and the applicable Condition(s) must be entered.

(continued)

SR 3.0.3 (continued) When the Surveillance is performed within the delay period and the Surveillance is not met, the LCO must immediately be declared not met, and the applicable Condition(s) must be entered.

SR 3.0.4 Entry into a specified Condition in the Applicability of an LCO shall not be made, unless the LCO's Surveillances have been met within their specified Frequency. This provision shall not prevent entry into specified conditions in the Applicability that are required to comply with Actions or that are related to the unloading of a NAC-UMS® SYSTEM.

CANISTER Maximum Time in Vacuum Drying
A 3.1.1

A 3.1 NAC-UMS® SYSTEM Integrity
A 3.1.1 CANISTER Maximum Time in Vacuum Drying

LCO 3.1.1 The following limits for vacuum drying time shall be met, as appropriate:

1. The time duration from completion of draining the CANISTER through completion of vacuum dryness testing and the completion of LCO A 3.1.3 shall not exceed the following time limits:

PWR

<u>Total Heat Load (L) (kW)</u>	<u>Time Limit (Hours)</u>	<u>Total Heat Load (L) (kW)</u>	<u>Time Limit (Hours)</u>
20 < L ≤ 23	27	11 < L ≤ 14	40
17.6 < L ≤ 20	30	8 < L ≤ 11	52
14 < L ≤ 17.6	33	L ≤ 8	103

BWR

<u>Total Heat Load (L) (kW)</u>	<u>Time Limit (Hours)</u>	<u>Total Heat Load (L) (kW)</u>	<u>Time Limit (Hours)</u>
20 < L ≤ 23	25	11 < L ≤ 14	45
17 < L ≤ 20	27	8 < L ≤ 11	72
14 < L ≤ 17	33	L ≤ 8	600

(continued)

CANISTER Maximum Time in Vacuum Drying
A 3.1.1

2. The time duration from the end of 24 hours of in-pool cooling or of forced air cooling of the CANISTER through completion of vacuum dryness testing and the completion of LCO A 3.1.3 shall not exceed the following limits:

<u>PWR Forced Air</u>		<u>PWR In-Pool</u>	
Total Heat <u>Load (L) (kW)</u>	Time Limit <u>(Hours)</u>	Total Heat <u>Load (L) (kW)</u>	Time Limit <u>(Hours)</u>
20 < L ≤ 23	3	20 < L ≤ 23	12
17.6 < L ≤ 20	6	17.6 < L ≤ 20	15
14 < L ≤ 17.6	9	14 < L ≤ 17.6	18
11 < L ≤ 14	16	11 < L ≤ 14	24
8 < L ≤ 11	27	8 < L ≤ 11	36
L ≤ 8	78	L ≤ 8	87

<u>BWR Forced Air</u>		<u>BWR In-Pool</u>	
Total Heat <u>Load (L) (kW)</u>	Time Limit <u>(Hours)</u>	Total Heat <u>Load (L) (kW)</u>	Time Limit <u>(Hours)</u>
20 < L ≤ 23	2	20 < L ≤ 23	10
17 < L ≤ 20	3	17 < L ≤ 20	11
14 < L ≤ 17	8	14 < L ≤ 17	17
11 < L ≤ 14	18	11 < L ≤ 14	26
L ≤ 11	41	L ≤ 11	52

Note: A CANISTER loaded with a fuel assembly having a burnup >45 GWd/MTU is limited to a total of nine (9) cooling/vacuum drying cycles performed in accordance with LCO 3.1.1.2.

APPLICABILITY: During LOADING OPERATIONS

(continued)

CANISTER Maximum Time in Vacuum Drying
A 3.1.1

ACTIONS

-----NOTE-----

Separate Condition entry is allowed for each NAC-UMS[®] SYSTEM.

CONDITION	REQUIRED ACTION	COMPLETION TIME
A. LCO time limits not met	A.1 Fill CANISTER with helium	2 hours
	<u>AND</u>	
	A.2.1.1 Place TRANSFER CASK with helium filled loaded CANISTER in spent fuel pool.	2 hours
	<u>AND</u>	
	A.2.1.2 Maintain TRANSFER CASK and CANISTER in spent fuel pool for a minimum of 24 hours	26 hours
<u>OR</u>		
A.2.2.1 Commence supplying air to the TRANSFER CASK annulus fill/drain lines at a rate of 375 CFM and a maximum temperature of 76°F	2 hours	
<u>AND</u>		
A.2.2.2 Maintain airflow for a minimum of 24 hours	26 hours	

SURVEILLANCE REQUIREMENTS

SURVEILLANCE	FREQUENCY
SR 3.1.1.1 Monitor elapsed time from completion of CANISTER draining operations until completion of LCO A 3.1.3.	As required to meet the time limit
SR 3.1.1.2 Monitor elapsed time from the end of in-pool cooling or of forced-air cooling until completion of LCO A 3.1.3.	As required to meet the time limit

A 3.1 NAC-UMS[®] SYSTEM Integrity
A 3.1.2 CANISTER Vacuum Drying Pressure

LCO 3.1.2 The CANISTER vacuum drying pressure, ≤ 10 mm of mercury (Hg), shall be held for a minimum of 10 minutes with the vacuum pump isolated and turned off, with the pressure remaining ≤ 10 mm of Hg during the 10-minute period.

APPLICABILITY: During LOADING OPERATIONS

ACTIONS

-----NOTE-----
Separate Condition entry is allowed for each NAC-UMS[®] SYSTEM.

CONDITION	REQUIRED ACTION	COMPLETION TIME
A. CANISTER vacuum drying pressure limit not met	A.1 Establish CANISTER cavity vacuum drying pressure within limit	25 days
B. Required Action and associated Completion Time not met	B.1 Remove all fuel assemblies from the NAC-UMS [®] SYSTEM	5 days

SURVEILLANCE REQUIREMENTS

SURVEILLANCE	FREQUENCY
SR 3.1.2.1 Verify CANISTER cavity vacuum drying pressure is within limits	Prior to TRANSPORT OPERATIONS.

A 3.1 NAC-UMS® SYSTEM Integrity
 A 3.1.3 CANISTER Helium Backfill Pressure

LCO 3.1.3 The CANISTER helium backfill pressure shall be 0 (+1, -0) psig.

APPLICABILITY: During LOADING OPERATIONS

ACTIONS

-----NOTE-----
 Separate Condition entry is allowed for each NAC-UMS® SYSTEM.

CONDITION	REQUIRED ACTION	COMPLETION TIME
A. CANISTER helium backfill pressure limit not met	A.1 Establish CANISTER helium backfill pressure within limit	25 days
B. Required Action and associated Completion Time not met	B.1 Remove all fuel assemblies from the NAC-UMS® SYSTEM	5 days

SURVEILLANCE REQUIREMENTS

SURVEILLANCE	FREQUENCY
SR 3.1.3.1 Verify CANISTER helium backfill pressure is within limit	Prior to TRANSPORT OPERATIONS.

CANISTER Maximum Time in TRANSFER CASK

A 3.1.4

A 3.1 NAC-UMS® SYSTEM Integrity

A 3.1.4 CANISTER Maximum Time in TRANSFER CASK

LCO 3.1.4 The total cumulative time a loaded and helium filled CANISTER may remain in TRANSFER CASK is limited to 600 hours. The following intermediate time limits for loaded and helium filled CANISTER time in TRANSFER CASK, without forced air or in-pool cooling, shall apply between cooling cycles. Canisters with total heat loads below those with intermediate limits are only limited by the 600 cumulative hours.

Total PWR Heat	Time Limit
<u>Load (L)(kW)</u>	<u>(Hours)</u>
$20 < L \leq 23$	20

Total BWR Heat	Time Limit
<u>Load (L)(kW)</u>	<u>(Hours)</u>
$20 < L \leq 23$	16
$17 < L \leq 20$	30

APPLICABILITY: During LOADING OPERATIONS, TRANSFER OPERATIONS, and UNLOADING OPERATIONS.

(continued)

CANISTER Maximum Time in TRANSFER CASK

A 3.1.4

ACTIONS

-----NOTE-----

Separate Condition entry is allowed for each NAC-UMS[®] SYSTEM.

CONDITION	REQUIRED ACTION	COMPLETION TIME
<p>A. ----NOTE ---- All time spent in Condition A is part of the 600 hour cumulative limit ----- Intermediate time limit not met</p>	<p>A.1.1 Place TRANSFER CASK with CANISTER in spent fuel pool</p> <p style="text-align: center;"><u>AND</u></p> <p>A.1.2 Maintain TRANSFER CASK and CANISTER in spent fuel pool for a minimum of 24 hours</p> <p style="text-align: center;"><u>OR</u></p> <p>A.2.1 Commence supplying air to the TRANSFER CASK annulus fill/drain lines at a rate of 375 CFM and a maximum temperature of 76°F</p> <p style="text-align: center;"><u>AND</u></p> <p>A.2.2 Maintain airflow for a minimum of 24 hours</p>	<p>2 hours</p> <p>26 hours</p> <p>2 hours</p> <p>26 hours</p>
<p>B. 600 hour cumulative time limit not met</p>	<p>B.1 Load CANISTER into CONCRETE CASK</p> <p style="text-align: center;"><u>OR</u></p> <p>B.2 Load CANISTER into TRANSPORT CASK</p> <p style="text-align: center;"><u>OR</u></p> <p>B.3 Remove all fuel assemblies from the NAC-UMS[®] SYSTEM</p>	<p>5 days</p> <p>5 days</p> <p>5 days</p>

(continued)

SURVEILLANCE REQUIREMENTS

SURVEILLANCE		FREQUENCY
SR 3.1.4.1	Monitor elapsed time for compliance with LCO 3.1.4	As required to meet the time limit

A 3.1 NAC-UMS® SYSTEM Integrity
A 3.1.5 CANISTER Helium Leak Rate

LCO 3.1.5 There shall be no indication of a helium leak at a test sensitivity of 1×10^{-7} cm³/sec (helium) through the CANISTER shield lid to CANISTER shell confinement weld to demonstrate a helium leak rate equal to or less than 2×10^{-7} cm³/sec (helium).

APPLICABILITY: During LOADING OPERATIONS

ACTIONS

-----NOTE-----

Separate Condition entry is allowed for each NAC-UMS® SYSTEM.

CONDITION	REQUIRED ACTION	COMPLETION TIME
A. CANISTER helium leak rate limit not met	A.1 Establish CANISTER helium leak rate within limit	25 days
B. Required Action and associated Completion Time not met	B.1 Remove all fuel assemblies from the NAC-UMS® SYSTEM	5 days

SURVEILLANCE REQUIREMENTS

SURVEILLANCE	FREQUENCY
SR 3.1.5.1 Verify CANISTER helium leak rate is within limit	Once prior to TRANSPORT OPERATIONS.

A 3.1 NAC-UMS® SYSTEM
A 3.1.6 CONCRETE CASK Heat Removal System

LCO 3.1.6 The CONCRETE CASK Heat Removal System shall be OPERABLE.

APPLICABILITY: During STORAGE OPERATIONS

ACTIONS

-----NOTE-----

Separate Condition entry is allowed for each NAC-UMS® SYSTEM.

CONDITION	REQUIRED ACTION	COMPLETION TIME
A. LCO not met	A.1 Ensure adequate heat removal to prevent exceeding short-term temperature limits	Immediately
	<u>AND</u>	
	A.2 Verify fuel loading meets CoC approved contents requirements	7 days
	<u>AND</u>	
	A.3 Restore CONCRETE CASK Heat Removal System to OPERABLE status	25 days
B. Required Actions A.1, A.2 or A.3 and associated Completion Times not met	B.1 Perform an engineering evaluation to determine that the CONCRETE CASK Heat Removal System is OPERABLE	5 days
	<u>OR</u>	
	B.2 Place the NAC-UMS SYSTEM in a safe condition	5 days

(continued)

SURVEILLANCE REQUIREMENTS		
	SURVEILLANCE	FREQUENCY
SR 3.1.6.1	Verify the difference between the ISFSI ambient temperature and the average outlet air temperature is $\leq 102^{\circ}\text{F}$ for the PWR canister or $\leq 92^{\circ}\text{F}$ for the BWR canister	24 hours
	<p style="text-align: center;"><u>OR</u></p> Visually verify all four air inlet and outlet screens are unobstructed	24 hours
SR 3.1.6.2	Verify the difference between the ISFSI ambient temperature and the average outlet air temperature is $\leq 102^{\circ}\text{F}$ for the PWR canister or $\leq 92^{\circ}\text{F}$ for the BWR canister	Once between 5 and 30 days after STORAGE OPERATIONS begin

[DELETED]

A 3.2 NAC-UMS® SYSTEM Radiation Protection
A 3.2.1 CANISTER Surface Contamination

- LCO 3.2.1 Removable contamination on the exterior surfaces of the CANISTER shall not exceed:
- a. 10,000 dpm/100 cm² from beta and gamma sources; and
 - b. 100 dpm/100 cm² from alpha sources.

APPLICABILITY: During LOADING OPERATIONS

ACTIONS

-----NOTE-----
Separate Condition entry is allowed for each NAC-UMS® SYSTEM.

CONDITION	REQUIRED ACTION	COMPLETION TIME
A. CANISTER removable surface contamination limits not met	A.1 Restore CANISTER removable surface contamination to within limits	Prior to TRANSPORT OPERATIONS

(continued)

SURVEILLANCE REQUIREMENTS

SURVEILLANCE	FREQUENCY
SR 3.2.1.1 Verify by either direct or indirect methods that the removable contamination on the exterior surfaces of the CANISTER is within limits	Once, prior to TRANSPORT OPERATIONS

A 3.2 NAC-UMS® SYSTEM Radiation Protection
A 3.2.2 CONCRETE CASK Average Surface Dose Rates

LCO 3.2.2 The average surface dose rates of each CONCRETE CASK shall not exceed the following limits unless required ACTIONS A.1 and A.2 are met.

- a. 50 mrem/hour (neutron + gamma) on the side (on the concrete surfaces);
- b. 50 mrem/hour (neutron + gamma) on the top;
- c. 100 mrem/hour (neutron + gamma) at air inlets and outlets.

APPLICABILITY: During STORAGE OPERATIONS

ACTIONS

-----NOTE-----
Separate Condition entry is allowed for each NAC-UMS® SYSTEM.

CONDITION	REQUIRED ACTION	COMPLETION TIME
A. CONCRETE CASK average surface dose rate limits not met	A.1 Administratively verify correct fuel loading <u>AND</u>	24 hours

(continued)

CONCRETE CASK Average Surface Dose Rate
A 3.2.2

CONDITION	REQUIRED ACTION	COMPLETION TIME
	A.2 Perform analysis to verify compliance with the ISFSI offsite radiation protection requirements of 10 CFR 20 and 10 CFR 72	7 days
B. Required Action and associated Completion Time not met.	B.1 Remove all fuel assemblies from the NAC-UMS [®] SYSTEM	30 days

SURVEILLANCE REQUIREMENTS

SURVEILLANCE	FREQUENCY
SR 3.2.2.1 Verify average surface dose rates of CONCRETE CASK loaded with a CANISTER containing fuel assemblies are within limits. Dose rates shall be measured at the locations shown in Figure A3-1.	Prior to STORAGE OPERATIONS

Figure A3-1 CONCRETE CASK Surface Dose Rate Measurement

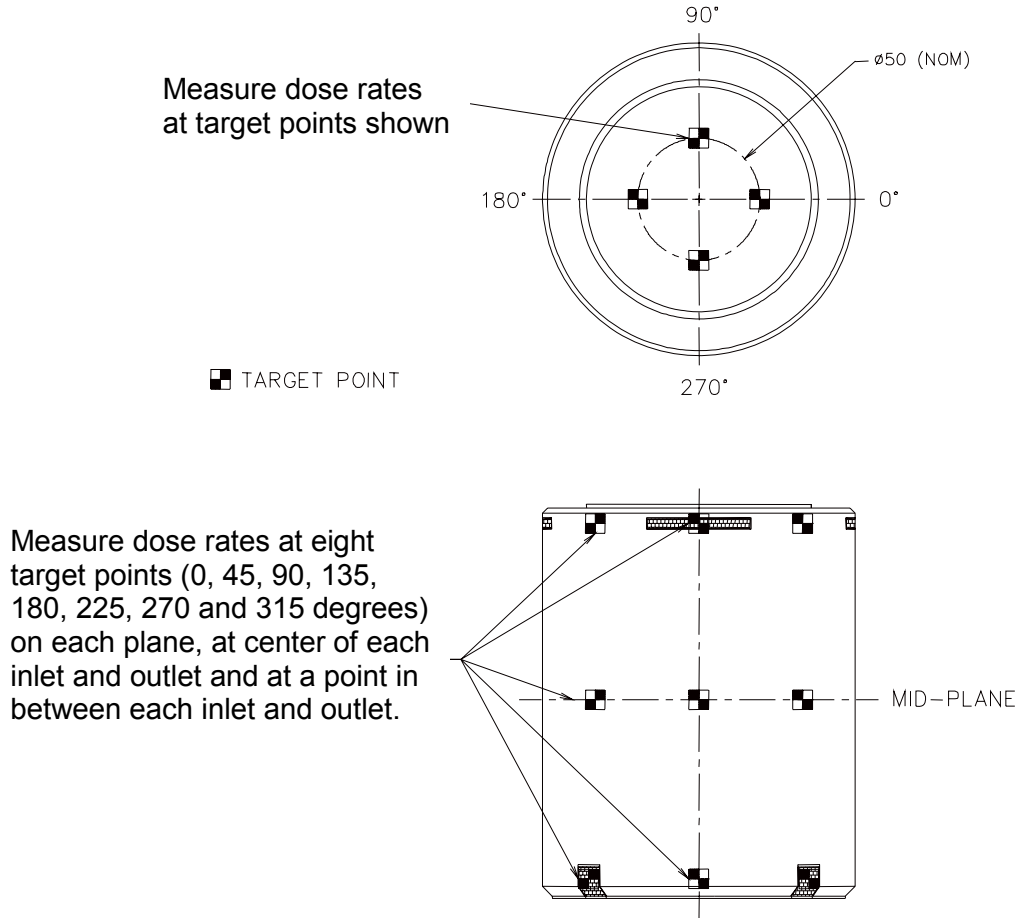

A 3.3 NAC-UMS® SYSTEM Criticality Control
A 3.3.1 Dissolved Boron Concentration

LCO 3.3.1 The dissolved boron concentration in the water in the CANISTER cavity shall be $\geq 1,000$ ppm.

APPLICABILITY: During LOADING OPERATIONS and UNLOADING OPERATIONS with water and at least one fuel assembly in the CANISTER that exceeds the enrichment limits in Table B2-2 for fuel assemblies taking no boron credit.

ACTIONS

-----NOTE-----
Separate Condition entry is allowed for each NAC-UMS® SYSTEM.

CONDITION	REQUIRED ACTION	COMPLETION TIME
A. Dissolved boron concentration not met.	A.1 Suspend loading of fuel assemblies into CANISTER and any other actions that increase reactivity	Immediately
	<u>AND</u> A.2 Initiate action to restore boron concentration to within limit	Immediately
	<u>AND</u> A.3.1 Restore boron concentration to within limit	24 hours
	<u>OR</u> A.3.2 Remove all fuel assemblies that exceed the enrichment limits of Table B2-2 for fuel assemblies taking no boron credit	24 hours

SURVEILLANCE REQUIREMENTS		
	SURVEILLANCE	FREQUENCY
SR 3.3.1.1	Verify the dissolved boron concentration is met using two independent measurements.	Once within 4 hours prior to commencing LOADING or UNLOADING OPERATIONS. <u>AND</u> Every 48 hours thereafter while the CANISTER is in the spent fuel pool or while water is in the CANISTER, except when no water is being introduced into the CANISTER cavity.

A 4.0 [Reserved]

A 5.0 ADMINISTRATIVE CONTROLS AND PROGRAMS

A 5.1 Training Program

A training program for the NAC-UMS[®] Universal Storage System shall be developed under the general licensee's systematic approach to training (SAT). Training modules shall include comprehensive instructions for the operation and maintenance of the NAC-UMS[®] Universal Storage System and the independent spent fuel storage installation (ISFSI).

A 5.2 Pre-Operational Testing and Training Exercises

A dry run training exercise on loading, closure, handling, unloading, and transfer of the NAC-UMS[®] Storage System shall be conducted by the licensee prior to the first use of the system to load spent fuel assemblies. The training exercise shall not be conducted with spent fuel in the CANISTER. The dry run may be performed in an alternate step sequence from the actual procedures, but all steps must be performed. The dry run shall include, but is not limited to the following:

- a. Moving the CONCRETE CASK into its designated loading area
- b. Moving the TRANSFER CASK containing the empty CANISTER into the spent fuel pool
- c. Loading one or more dummy fuel assemblies into the CANISTER, including independent verification
- d. Selection and verification of fuel assemblies requiring preferential loading
- e. Installing the shield lid
- f. Removal of the TRANSFER CASK from the spent fuel pool
- g. Closing and sealing of the CANISTER to demonstrate pressure testing, vacuum drying, helium backfilling, welding, weld inspection and documentation, and leak testing
- h. TRANSFER CASK movement through the designated load path
- i. TRANSFER CASK installation on the CONCRETE CASK
- j. Transfer of the CANISTER to the CONCRETE CASK

(continued)

A 5.2 Pre-Operational Testing and Training Exercises (continued)

- k. CONCRETE CASK shield plug and lid installation
- l. Transport of the CONCRETE CASK to the ISFSI
- m. CANISTER unloading, including reflooding and weld removal or cutting
- n. CANISTER removal from the CONCRETE CASK

Appropriate mockup fixtures may be used to demonstrate and/or to qualify procedures, processes or personnel in welding, weld inspection, vacuum drying, helium backfilling, leak testing and weld removal or cutting.

A 5.3 Special Requirements for the First System Placed in Service

The heat transfer characteristics and performance of the NAC-UMS[®] SYSTEM will be recorded by air inlet and outlet temperature measurements of the first system placed in service with a heat load equal to or greater than 10 kW. A letter report summarizing the results of the measurements will be submitted to the NRC in accordance with 10 CFR 72.4 within 30 days of placing the loaded cask on the ISFSI pad. The report will include a comparison of the calculated temperatures of the NAC-UMS[®] SYSTEM heat load to the measured temperatures. A report is not required to be submitted for the NAC-UMS[®] SYSTEMS that are subsequently loaded, provided that the performance of the first system placed in service with a heat load \geq 10 kW is demonstrated by the comparison of the calculated and measured temperatures.

A 5.4 Surveillance After an Off-Normal, Accident, or Natural Phenomena Event

A Response Surveillance is required following off-normal, accident or natural phenomena events. The NAC-UMS[®] SYSTEMS in use at an ISFSI shall be inspected within 4 hours after the occurrence of an off-normal, accident or natural phenomena event in the area of the ISFSI. This inspection must specifically verify that all the CONCRETE CASK inlets and outlets are not blocked or obstructed. At least one-half of the inlets and outlets on each CONCRETE CASK must be cleared of blockage or debris within 24 hours to restore air circulation.

The CONCRETE CASK and CANISTER shall be inspected if they experience a drop or a tipover.

(continued)

A 5.5 Radioactive Effluent Control Program

The program implements the requirements of 10 CFR 72.126.

- a. The NAC-UMS[®] SYSTEM does not create any radioactive materials or have any radioactive waste treatment systems. Therefore, specific operating procedures for the control of radioactive effluents are not required. LCO 3.1.5, CANISTER Helium Leak Rate, provides assurance that there are no radioactive effluents from the NAC-UMS[®] SYSTEM.
- b. This program includes an environmental monitoring program. Each general license user may incorporate NAC-UMS[®] SYSTEM operations into their environmental monitoring program for 10 CFR Part 50 operations.

A 5.6 NAC-UMS[®] SYSTEM Transport Evaluation Program

This program provides a means for evaluating various transport configurations and transport route conditions to ensure that the design basis drop limits are met. For lifting of the loaded TRANSFER CASK or CONCRETE CASK using devices that are integral to a structure governed by 10 CFR Part 50 regulations, 10 CFR 50 requirements apply. This program is not applicable when the TRANSFER CASK or CONCRETE CASK is in the fuel building or is being handled by a device providing support from underneath (i.e., on a rail car, heavy haul trailer, air pads, etc.).

Pursuant to 10 CFR 72.212, this program shall evaluate the site specific transport route conditions.

- a. The lift height above the transport surface shall not exceed the limits in Table A5-1.

(continued)

A 5.6 NAC-UMS[®] SYSTEM Transport Evaluation Program (continued)

- b. For site-specific transport conditions that are not bounded by Section 11.2.4 of the NAC-UMS[®] Final Safety Analysis Report, the program may evaluate the site-specific conditions to ensure that the impact loading due to site-specific drop events does not exceed 60g. This alternative analysis shall be commensurate with the drop analyses described in the Final Safety Analysis Report for the NAC-UMS[®] SYSTEM. The program shall ensure that these alternative analyses are documented and controlled.
- c. The TRANSFER CASK and CONCRETE CASK may be lifted to those heights necessary to perform cask handling operations, including CANISTER transfer, provided the lifts are made with structures and components designed in accordance with the criteria specified in Section B3.5 of Appendix B to CoC No. 1015, as applicable.

A 5.7 [Deleted]

Table A5-1 TRANSFER CASK and CONCRETE CASK Lifting Requirements

Item	Orientation	Loaded Cask Lifting Height Limit
TRANSFER CASK	Horizontal	Not Permitted
TRANSFER CASK	Vertical	None Established ¹
CONCRETE CASK	Horizontal	Not Permitted
CONCRETE CASK	Vertical	< 24 inches

Note:

1. See Technical Specification A5.6(c).