

Type: Technical - Reference**Effective Date: 06/04/07**

**SPECIFICATIONS FOR INSTALLATION OF PIEZOMETERS
AND MONITORING WELLS**

1.0 PURPOSE

This procedure provides procedures for the installation of piezometers and monitoring wells at the Savannah River Site (SRS).

2.0 SCOPE

These procedures are applicable to any department, organization, group, subcontractor or person planning to install a monitoring well or piezometer at SRS. Deviations from this procedure are allowed with the approval of the Site Groundwater Permitting Coordinator (SGPC) and documented in the program plan, work plan, or sampling plan.

This is a Reference procedure. The user is not required to have this procedure present while performing the activity.

The following OSR form shall be utilized in the performance of this procedure:

OSR 30-11, SRS Well Installation Report.

3.0 GENERAL INFORMATION**3.1 Precautions and Limitations**

Additional hazard analysis may be required to ensure that facility/job specific hazards are identified and that the appropriate actions are taken to eliminate/mitigate the identified hazard(s).

3.2 Prerequisite Actions

None.

3.3 Terms/Definitions

Refer to Glossary.

4.0 RESPONSIBILITIES

- The Project Manager (PM) shall submit a Program Plan (**SEE** Procedure 1 of this manual) to the SGPC for approval. The appropriate permits shall be obtained prior to startup of the project. The PM shall ensure that OSR 30-11 is completed and submitted to the SGPC within 30 days of project completion.
- A South Carolina Certified driller is responsible for well installation in accordance with S.C. Code of Laws Title 40 Chapter 23 Environmental Certification Board.
- The Subcontract Technical Representative (STR), PM, or designee will provide a pre-job briefing for the drilling subcontractor and the Technical Oversight (TO) prior to the startup of work.
- The STR, PM, or designee will coordinate activities with the drilling subcontractor and TO.
- Independent TO, as detailed in Procedure 4 of this manual, will be present at the drill site to document that the specifications and procedures outlined herein are followed.

5.0 PROCEDURE

5.1 Equipment

The drill rig shall be capable of, and equipped with, the necessary accessories to drill the specified diameter borehole to the required depth in a safe manner. The drill bit and all down-hole tools shall be free of paint and grease.

The following is a list of equipment that may be used in piezometer and well installations:

- drill rig, water truck, and support trucks in good mechanical condition, all with the necessary equipment to complete the specified work
 - core barrel and related equipment
 - grout pumps, water pumps, hoses, and mixing tanks
 - portable mud pan
 - core boxes as required
 - plastic sheeting (minimum 4 mil thickness) for leaking equipment
-

5.1 Equipment, continued

- pressure washer
- tremie pipe (PVC or steel) for pumping grout
- tremie pipe (PVC or steel) for placement of filter pack, and bentonite pellets
- well development equipment including air compressors (with filters), surge blocks, bailers, reverse airlift lines, etc.

5.2 Construction Materials

The materials itemized below make up a comprehensive listing of those items that may be used for installation of piezometers and/or monitoring wells at the SRS. The SGPC's office may allow substitutions, deletions, or changes to the following materials as required on a project-by-project basis.

- Sodium Bentonite Powder
 - Filter pack (silica sand)
 - Bentonite Seal: 3/8- to 1/2-inch uncoated bentonite pellets. With approval from the STR, Hole plug™, coated pellets, or other bentonite products may be used.
 - Grout: Class A, Type I Portland Cement or high solids bentonite grout.
 - Steel surface casing: typically eight-, ten-, or twelve-inch diameter steel pipe with a minimum 0.250-inch wall thickness, with threaded and coupled ends. Details regarding surface casing installation are contained in Section 5.5. The pipe shall have no mill coating.
 - PVC well casing: typically watertight flush-joint Schedule 40 PVC. PVC casing is generally used in piezometers or monitoring wells less than 300 feet in depth. O-rings are typically left on or installed as part of the casing threads. Diameter, slot width, and spacing will vary based upon job requirements.
 - Steel well casing: typically threaded and coupled black carbon steel pipe with no mill coating. Casing shall have a minimum wall thickness of 0.237 inches. Steel casing is generally used in monitoring wells greater than 300 feet in depth.
 - PVC slotted screen: typically flush-joint Schedule 40 PVC. Slot spacing is typically 0.125 inches. Diameter, slot width, and spacing will vary based upon job requirements.
-

Hydrogeologic Data Collection Procedures and Specifications	Manual:	3Q5
	Procedure:	7
	Revision:	5
Specifications for Installation of Piezometers and Monitoring Wells	Page:	4 of 22

5.2 Construction Materials, continued

- Stainless steel screen: continuous wire-wound non-clogging stainless steel with threaded couplings. Diameter, slot width and screen diameter will vary based upon job requirements.
- PVC wire-wrapped screen: continuous, wire-wound PVC, non-solvent welded with threaded couplings which will mate with the PVC casing specified above. Diameter, slot width and screen diameter will vary based upon job requirements.
- Centralizers: typically constructed of PVC or stainless steel and attached to the casing with stainless steel screws or clamps. Centralizer ribs shall have sufficient strength to adequately center the casing in the drill hole. Centralizers for steel surface casing may be carbon steel and welded to the casing.
- PVC bottom plug: shall be Schedule 40 or 80 PVC with a flush-joint coupling, or approved equivalent.
- Steel bottom plug: typically threaded and coupled black carbon steel Schedule 40 with no mill coating. An end cap may also be attached directly to the bottom of the screen or sump.

5.3 Geologic Sampling/Geophysical Logging

- Formation samples are usually collected from the deepest borehole in each well cluster or from a single borehole where no other wells are installed. Sampling methods may include: continuous coring, split spoon sampling, grab samples, wash cuttings, shelly tubes, pitcher barrels, or any combination of these methods.
 - Split spoon, grab or wash samples should be stored in resealable plastic bags, glass jars, or core boxes. The samples should be labeled with indelible ink indicating boring or well number and sample interval. The proper handling and boxing of core is described in Attachment 1. Field geologic log forms will be completed by the TO which describe all samples collected.
 - The borehole may be geophysically logged. Specific logs may include: sonic, self-potential, single point resistance, short and long normal resistivity, natural gamma, and caliper. Other geophysical logging may be conducted as specified by the PM or the STR and with the approval of the SGPC's office.
 - The final design criteria for each piezometer or monitoring well, including the total depth, screened interval, screen type, filter pack, and slot size will be based upon hydrologic conditions, analysis of formation materials, and interpretation of geophysical logs.
-

5.4 Well Drilling, Casing Installation, and Grouting

- Water source - Potable water shall be used for drilling, installation, and development of all environmental monitoring wells and piezometers. Non potable water from a source approved by the STR or SGPC may be used for core holes, geotechnical borings, installation of tomography or inclinometer casing, or other boreholes in which monitoring wells are not installed. Non potable water must be tested prior to use to ensure that no contaminants are introduced into the groundwater during the drilling process.
- The area around the work site shall be surrounded by a rope barricade with the appropriate warning tags before work commences or the drill rig mast is raised to the vertical position. A sheet of 4 mil (minimum) plastic shall be spread beneath the full length and width of the drill rig before work begins.
- All connections between drill rods that require lubrication shall use a non-petroleum based lubricant approved for environmental applications.
- Unless directed otherwise by the PM or STR, prior to initial use at SRS and between wells, the part of the drill rig that has come in contact with potentially contaminated formation materials and all down-hole equipment shall be pressure washed with hot water at a location or area specified by the PM or STR. All other equipment that has the potential to introduce contaminants into the borehole (mud pumps, hose lines, etc.) will be flushed clean with water prior to use.
- The exact location of the well should be graded in such a manner to preclude surface water from ponding around the well or running over the well pad.
- The borehole will be drilled using the appropriate drilling method as determined by the STR. A minimum 1.5 inch annulus is required. Care must be taken to ensure that the borehole is straight and plumb. If required by the STR, borehole deviation surveys may be conducted.
- The installation of temporary or permanent surface casing may be required to prevent contaminants from being carried into deeper aquifers during the drilling process or in the event of borehole caving (**SEE** Section 5.5). The casing diameter and installation depth will be determined by the PM or STR.
- After drilling to the total depth of the borehole, the drilling fluid will be flushed from the hole with clean potable water until the viscosity is reduced.

<p>NOTE: Drilling fluid for mud rotary only, not for hollow stem auger or roto sonic.</p>
--

5.4 Well Drilling, Casing Installation, and Grouting, continued

- After the hole has been properly conditioned, the drill string will be removed. If the borehole has been augered or drilled using roto sonic methods the augers or drill rods may be left in the borehole during well installation.
 - The well casing and screen assembly is placed in the borehole using the following procedures (**SEE** Attachment 2, Figure 1):
 - A length of blank casing may be set below the screen to act as a sediment sump. A bottom plug will be attached to the bottom of the blank section. Sump length will vary or be eliminated based on geologic conditions.
 - Screen type, length, and setting will be based upon subsurface conditions as determined from geologic information, geophysical data, or program specific requirements. The screen slot size will be appropriate for the screened interval as determined by the TO, STR, or PM.
 - Centralizers will be placed one foot above and one foot below the screen and at approximately 40-foot intervals along the casing of monitoring wells. Wells installed using hollow-stem auger methods do not require centralizers.
 - Installation of filter pack and bentonite seal.
 - If hollow stem augers have been used to drill the borehole the well will be set through the augers. The annulus between the borehole wall and the well screen will be filled with filter pack as the augers are withdrawn. The sand and bentonite will be poured directly into the space between the augers and well. If there is a problem with formation sand filling the inside of the augers a plug or pilot bit can be placed in the bottom auger, or the augers can be filled with potable water. The wooden plug shall not be pressure treated wood.
 - If roto sonic methods are used to drill the borehole the sand and bentonite may be installed using a tremie or poured from the surface using the drill rods as tremie.
 - If mud rotary drilling methods have been used the filter pack and bentonite shall be tremied in starting with the tremie pipe near the bottom of the borehole. Potable water may be used during installation of the filter pack and bentonite seal. The tremie pipe will be withdrawn from the annulus as the filter pack accumulates. Care shall be taken to prevent bridging of sand in the annulus. The tremie pipe used in this operation shall be free of any cement grout coating.
-

5.4 Well Drilling, Casing Installation, and Grouting, continued

The filter pack will extend approximately two feet above the top of the screen unless geologic conditions necessitate a variance. The depth to the top of the filter pack shall be measured with a weighted tag line and the depth verified by the TO.

- Approximately four feet of bentonite will be installed above the filter pack and allowed to hydrate a minimum of two hours before grouting. If the bentonite seal is above the water, clean potable water will be added periodically to aid in hydration of the pellets. The depth to the top of the bentonite shall be measured by a weighted tag line and the depth verified by the TO. If a well has multiple screens with a bentonite seal between the screen zones, the bentonite does not require a 2-hour hydration time prior to installing the filter pack for each subsequent screen zone. However, the 2-hour hydration time is required for the last bentonite seal.
- Grout types and mixes are as follows:
 - Neat cement grout: Class A, Type I Portland Cement mixed with not more than (7) gallons of water per bag (one cubic foot or 94 lbs.) of cement with a density of 15 to 16 pounds per gallon, or to manufacturer's specifications.
 - Bentonite-cement grout: Shall be composed of powdered bentonite (less than 5% by weight) mixed at not more than 8 gallons of water to the bag of Class A, Type I Portland Cement, with a density of 14 to 15 pounds per gallon, or to manufacturer's specifications.
 - High solids bentonite grout shall have a minimum of 20% solids and be mixed per manufacturer's specifications with water and/or other required additives.
- A tremie pipe will be placed in the annulus to a depth just above the bentonite seal. Grouting may be accomplished in a single or multiple stages. Grout shall extend from the top of the bentonite seal to approximately 2 feet below grade. If the grout column subsides, additional grout will be added. If the top of the grout column is visible from the surface and it can be verified there is no fill material, additional grout may be poured from the surface to bring the grout to within 2 feet of the ground surface. If the top of the grout column is not visible from the surface or there is fill on top of the grout, the fill must be removed from the borehole and grouted to 2 feet using tremie pipe. The remaining 2 feet of annulus shall either be covered in such a way that no water will stand in the annulus or filled to the surface with bentonite. The final grout stage must be allowed to cure for a minimum of 24 hours before well development is initiated.

5.4 Well Drilling, Casing Installation, and Grouting, continued

- The well casing shall extend approximately 2.5 feet above the ground surface. Stick up may vary or be eliminated based on well completion requirements.
- All monitoring wells shall be properly labeled with an identification plate immediately upon well completion (i.e., grouted to approximately 2 feet below grade). It shall be constructed of a durable, weatherproof, rustproof material and permanently secured to the well casing or protective casing where it is readily visible. It shall be permanently marked to show:
 - Company name and certification number of the driller who installed the well
 - Date well was completed
 - Total depth (feet)
 - Casing depth (feet)
 - Screened interval
 - Designator and /or identification number
 - Static water level.

5.5 Use of Surface Casing

Surface casing is casing of a larger diameter than the well or piezometer, that extends from the ground surface down to a specified depth. Surface casing is used for one or more of the following reasons:

- To reduce the potential for downward migration of contaminants from one aquifer to another.
- To seal off zones in which drilling fluid is lost at an excessive rate. (surface casing is usually placed immediately after encountering problem zone).
- To seal off zones of unconsolidated sand or other materials where caving or bridging of the hole occurs. (surface casing is usually placed immediately after encountering problem zone).
- To stabilize surface soils in the vicinity of the drilling rig.

The PM or STR must decide whether or not surface casing is required, using the following guidelines:

- Wherever wells are completed in an aquifer known to be separate from an overlying aquifer and all of the following apply:
 - o The overlying aquifer is known to be contaminated.
 - o The underlying aquifer is known to be uncontaminated with the constituents present in the overlying aquifer.
 - o There is appreciable downward potential for water flow between the two aquifers.
-

5.5 Use of Surface Casing, continued

- To establish an adequate seal, the surface casing must be set within the confining unit separating the contaminated aquifer from all underlying aquifers. The confining unit must be at least three feet thick. The surface casing shall be set in the confining unit directly below the contaminated aquifer.
- Surface casing may be required in occasional instances in which the criteria listed above do not exist. The SGPC's office will notify the PM and STR as these situations arise.

5.6 Installation of Surface Casing

Surface casing may be permanent or temporary, depending upon the particular job requirements. If the installation is permanent, the casing is grouted in place. If the installation is to be permanent, an inner well casing will be installed and the annular space between the two will be grouted.

5.6.1 Installation of Temporary Surface Casing

Temporary casing unrelated to aquifer protection concerns may be installed to control drilling fluid loss and deeper hole caving problems.

Temporary surface casing used for aquifer protection may also be installed using rotosonic drilling methods. The surface casing is installed to the required depth. The casing may then be pressured with water to determine if it is properly sealed. The borehole is then advanced inside the temporary surface casing to the desired depth. The surface casing is removed as the well is completed. Multiple temporary surface casings may be set using rotosonic methods.

5.6.2 Installation of Permanent Surface Casing

- Permanent surface casing is typically 8, 10, or 12-inch diameter steel or PVC pipe with threaded and coupled, or flush coupled ends. Surface casing can vary based on technical requirements. The minimum diameter must allow for the well to have a 1.5 inch annulus. The use of any pipe other than that specified in Section 5.2 shall be approved by the SGPC's office prior to installation.
 - The borehole shall be reamed to a diameter approximately six inches greater than the outside diameter of the casing. The reamed borehole will then be flushed with drilling fluid to remove all excess cuttings.
-

Hydrogeologic Data Collection Procedures and Specifications	Manual:	3Q5
	Procedure:	7
	Revision:	5
Specifications for Installation of Piezometers and Monitoring Wells	Page:	10 of 22

5.6.2 Installation of Permanent Surface Casing, continued

- No "grout windows" will be cut in the bottom of the casing. Steel centralizers may be placed at the bottom of the casing and approximately every 40 feet along the length of the casing and just below ground surface.
- Casing will be measured and tallied by the TO prior to installation.
- Once the casing is in place, it shall be properly supported and grouted as quickly as possible. Grouting may be accomplished by using either the pressurized header or tremie pipe method. The specific grouting technique shall be determined by the TO or STR. When using the pressurized header method, the header shall be attached to the top piece of casing and shall be free of leaks. The opening for the tremie pipe, valves and gauges shall also be free of leaks during and after pumping the grout.
- A standard grout mix (**SEE** Section 5.4) will be used in grouting the casing.
- Grout will be pumped continuously until either no more is available or clean grout returns to the ground surface. The casing shall then remain undisturbed for a minimum period of 24 hours. During this period, additional grout may be pumped into the annulus by tremie pipe as necessary to bring the grout level up to ground surface.
- If the header method was used in grouting, a grout plug should be present inside the casing at the bottom.
- The grout plug will then be drilled out to the original depth of the reamed hole. The grout-contaminated drilling fluid shall be flushed from the borehole and disposed of as directed by the PM or STR. Fresh mud will be mixed and construction of the well (coring or drilling) may continue.

5.7 Piezometer and Monitoring Well Development

- Well development shall not be initiated within 24 hours of the installation of the final stage of grout.
- The development method chosen will depend upon the location, purpose, condition of the well, strata encountered, type of filter pack, screen size, etc.

Hydrogeologic Data Collection Procedures and Specifications	Manual:	3Q5
	Procedure:	7
	Revision:	5
Specifications for Installation of Piezometers and Monitoring Wells	Page:	11 of 22

5.7 Piezometer and Monitoring Well Development, continued

- Development may be accomplished by air lifting with reverse air, pumping, bailing, jetting, swabbing, or any combination of the above methods, as specified by the TO or STR. Only potable water shall be used in monitoring well development.
- Development shall continue until clear, sediment-free water is consistently produced. If possible the well should be developed until the turbidity is <15 Nephelometer Turbidity Units (NTUs). Development parameter measurements shall be documented.
- Any sediment that has accumulated in the sump during development shall be removed.
- Measurements to be taken during development may include specific conductance, pH, temperature, turbidity, and yield.
- The development techniques used shall be documented. This documentation shall include a log of the time intervals of the various development processes used.
- If development of the well is done by air surging or air lift pump, the air from the compressor shall be filtered as necessary to be completely free of oil
- Proper well development may require the use of additives such as sodium phosphate which expedite the breakdown of drilling fluids that are trapped in the formation.

5.8 Piezometer Completion (Materials Specifications and Installation)

The following material specifications and installation details are made with respect to Attachment 2, Figure 2, Piezometer Pad Construction Diagram.

- Concrete pad: a 2-foot by 2-foot by 6-inch, concrete-formed pad which is centered around the piezometer. The pad shall be constructed into the ground three inches. The pad surface shall be sloped so that water will flow away from the piezometer. Pad size may vary depending on physical constraints in the area immediately surrounding the piezometer. At a minimum the pad shall extend no less than 6 inches beyond the borehole diameter.

5.8 Piezometer Completion (Materials Specifications and Installation), continued

- Protective posts: At the direction of the PM, three heavy-gauge five-foot long steel fence posts will be installed around each piezometer pad, three feet away from the piezometer and spaced 120° apart. The posts will be driven into the ground two feet. At the discretion of the PM the posts may be configured differently or eliminated.
- Locking cap: A leak-proof, tamper-resistant locking cap will be attached to the piezometer casing.
- PVC casing: The PVC casing will extend approximately 2.5 feet above the ground surface.
- Piezometer identification sign: An identification sign provided by WSRC will be attached to one of the protective posts or to the well if no posts are installed.

5.9 Monitoring Well Completion (Materials Specifications and Installation)

The following material specifications and installation details are made with respect to wells displayed in the following figures:

- | | |
|-------------------------|--|
| Attachment 3, Figure 3 | Well Pad and Wellhead Construction Diagram for wells that receive a single speed submersible pump. |
| Attachment 3, Figure 3a | Pump and Associated Hardware Details for wells that receive a single speed submersible pump. |
| Attachment 4, Figure 4 | Well Pad and Wellhead Construction Diagram for wells that receive a variable speed submersible pump. |
| Attachment 4, Figure 4a | Pump and Associated Hardware Details for wells that receive a variable speed submersible pump. |

- Concrete pad: A 42 inch wide by 30 inch deep by 6-inch thick, concrete-formed pad will be approximately centered around the well. The pad shall be recessed into the ground approximately three inches. The pad surface shall be completed so that water will not pool on the pad. Pad size may vary depending on the physical constraints in the area immediately surrounding the well. At a minimum the pad shall extend no less than 6 inches beyond the borehole diameter.
-

Hydrogeologic Data Collection Procedures and Specifications	Manual:	3Q5
	Procedure:	7
	Revision:	5
Specifications for Installation of Piezometers and Monitoring Wells	Page:	13 of 22

5.9 Monitoring Well Completion (Materials Specifications and Installation), continued

- Protective posts: If wells are located in high traffic areas, a minimum of three 4-inch diameter by 5-foot long hollow steel posts should be placed adjacent to the pad. The posts should be configured as illustrated in Attachments 3 and 4. They should extend approximately 42 inches above the top of the pad, be cemented into the ground, filled with concrete, and painted on the exterior with high visibility yellow paint (Rustoleum™ Federal Safety Yellow #944 or equivalent). At the discretion of the PM the posts may be configured differently.
- Protective housing: For a 4-inch diameter well, a 6-inch by 6-inch square by 5-foot long square steel housing with a locking hinged cap will be placed over the well housing. For a 2-inch diameter well, the protective housing will be 4 inches by 4 inches square. The hinged cap will be 6 inches in height (inclusive in the 5-foot length). The protective housing will be filled with bentonite, cement, or concrete from the top of the grout column to approximately pad level. A ¼ inch diameter weep hole will be drilled in the protective housing just above the grout level inside the casing. The exterior of the housing will be painted with high visibility yellow paint (Rustoleum™ Federal Safety Yellow #944 or equivalent). The size of the protective casing may vary due to sampling requirements.
- Flow meter support pipe: A 3-inch PVC Schedule 40 pipe which extends approximately 2 feet below the concrete pad will support the flow meter. It will be capped with a flat 3-inch PVC Schedule 40 cap. It will extend above the pad to a point where the flow meter will rest lightly on top.
- Well number identification sign and mounting post: A well identification sign will be attached to a 3-inch by 5-foot galvanized steel sign post that will be embedded into the concrete pad.

Parts unique to a well that receives a 4-inch single speed pump (Attachment 3, Figure 3 and 3a)

- Ground rod: A 1/2-inch by 10-foot long copper-clad ground rod will be driven into the ground so that approximately 3 inches of the rod extends above the top of the completed concrete pad.
- Ground wire: A #4 bare copper ground wire will be attached to the ground rod with a grounding clamp.
- Security cable: A 3/16-inch 300 Series stainless steel cable will be attached to the pump. Stainless steel wire rope clamps will be used to form the loop that holds the pump.

5.9 Monitoring Well Completion (Materials Specifications and Installation), continued

Parts unique to a well that receives a 4-inch single speed pump (Attachment3, Figures 3 and 3a)

- Electrical conduit assembly: This assembly consists of the following parts in order of connection from the well seal to the electrical box: a 1/2-inch by 4-inch steel nipple, a 1/2-inch by 3/4-inch bell coupling, a 90° Sealtite Anaconda™ conduit connector or equivalent, a 3/4-inch Sealtite Anaconda™ conduit or equivalent, and a 90° Sealtite Anaconda™ conduit connector or equivalent.
 - Submersible electrical cable: A 3-wire or 4-wire submersible pump motor cable.
 - Electrical box: A three-component system consisting of: a Hubbell FD-2 aluminum enclosure or equivalent, a Hubbell WP-2 weatherproof gray Lexan™ cover or equivalent and a Hubbell 2715 NEMA L14-30, 4-prong twist-lock male receptacle or equivalent.
 - Pump: The pump shall be a Grundfos model 10S05-9. The stainless steel, 1/2 horsepower, 115V, 3-wire or 4-wire pump will be attached to the riser pipe with a 1 1/4-inch to 1-inch PVC bushing. At the direction of the PM or STR, different pumps may be installed to support specific sampling requirements.
 - Riser pipe: For 4-inch wells, a 1-inch Schedule 80 PVC pipe with threaded couplings.
 - Liquid level pipe: For 4-inch wells, a 1-inch PVC Schedule 40 flush-joint pipe with a flush-joint bottom plug. The bottom 10 feet of pipe will be perforated to allow for fluid flow. The top joint of the pipe must have a male National Pipe Thread (NPT) adapter installed.
 - Well seal: Typically cast iron with rubber packing seal, bored to accommodate the riser pipe, liquid level pipe, security cable, and electrical cable. The well seal may vary based on pump type. At a minimum the sanitary seal shall be sufficient to prevent debris from entering the well.
 - 1-inch Schedule 80 PVC threaded coupling
 - 1-inch Schedule 80 PVC threaded plug
 - 1-inch 90° Schedule 80 PVC threaded elbow
-

5.9 Monitoring Well Completion (Materials Specifications and Installation), continued

Parts unique to a well that receives a 2-inch variable speed submersible pump (Attachment 4, Figure 4a)

- Pump: Grundfos Redi-Flo 2. No safety cable is attached to the pump. The electrical wire will be trimmed to an approximate length of 6-12 inches above the well casing and be placed inside the hinged cover of the protective casing. At the direction of the PM or STR, different pumps may be installed to support specific sampling requirements.
- Riser pipe: 3/4-inch Schedule 80 pipe with threaded couplings
- Well seal: a 2-inch slip cap with a 3/4-inch hole to accommodate the riser pipe and a small hole for the pump electrical cable. The well seal may vary based on pump type. At a minimum the sanitary seal shall be sufficient to prevent debris from entering the well.
- 3/4-inch female to 1-inch male Schedule 80 PVC threaded bushing
- 1-inch Schedule 80 PVC threaded Tee
- 1-inch Schedule 80 PVC threaded plug

Parts common to 2-inch and 4-inch well completions (Attachment 3, Figure 3a and Attachment 4, Figure 4a)

- 1-inch by 4-inch Schedule 80 PVC threaded nipple
 - 1-inch Schedule 80 PVC threaded Tee
 - 1-inch male to a 1/4-inch female Schedule 80 PVC threaded bushing
 - 1/4-inch PVC threaded male to male ball valve
 - 1/4-inch PVC threaded coupling
 - 1/4-inch by 6-inch PVC threaded nipple
 - 1/4-inch PVC threaded cap
 - 1-inch by 3-inch Schedule 80 PVC threaded nipple
 - 1-inch threaded bronze gate valve
-

Hydrogeologic Data Collection Procedures and Specifications	Manual:	3Q5
	Procedure:	7
	Revision:	5
Specifications for Installation of Piezometers and Monitoring Wells	Page:	16 of 22

5.9 Monitoring Well Completion (Materials Specifications and Installation), continued

Parts common to 2-inch and 4-inch well completions (Attachment 3, Figure 3a and Attachment 4, Figure 4a)

- 1-inch meter adapter with connector nut and gasket
- Flow meter: totalizing flow meter with a nominal 10 gpm capacity. Master Meter-MM5F.P. or approved equivalent
- Stainless steel security cable: 3/16-inch 300 Series stainless steel security cable with aluminum sleeves
- 1-inch 90° Schedule 80 PVC threaded elbow
- 1-inch male to a 3/4-inch female Sch 80 PVC threaded bushing and 3/4 by 3-inch Sch 80 threaded nipple. A one-piece reducer/nipple combination may also be used.
- Plastic discharge hose: 1-inch x 8-foot plastic discharge hose with stainless steel clamp. The discharge hose may be eliminated for purge water containerization wells.

5.9.1 Well Point Construction Diagram (Attachment 5, Figure 5)

The specific design of a well point will vary with location and geologic conditions. The exact design for each well point shall be included by the PM in the program plan for approval.

6.0 RECORDS

Records generated as a result of implementing this procedure are processed in accordance with Procedure Manual 1B, Procedure 3.31¹.

OSR 30-11, SRS Well Installation Report.

Hydrogeologic Data Collection Procedures and Specifications	Manual:	3Q5
	Procedure:	7
	Revision:	5
Specifications for Installation of Piezometers and Monitoring Wells	Page:	17 of 22

7.0 REFERENCES

¹Procedure Manual 1B, Procedure 3.31, Records Management

Driscoll, F. G., 1986, Groundwater and Wells: Johnson Division, U.O.P., Inc.

EPA (U.S. Environmental Protection Agency), 1996, Engineering Support Branch Standard Operating Procedures and Quality Assurance Manual, Environmental Services Division, Region IV. May 1

South Carolina Well Standards and Regulations: R.61-71, 2002.

8.0 ATTACHMENTS

1. Boxing of SRS Drill Cores
 2. Figure 1, Piezometer and Monitoring Well Construction Diagram
 2. Figure 2, Piezometer Pad Construction Diagram
 3. Figure 3, Well Pad and Wellhead Construction Diagram for Wells that receive a Single Speed Submersible Pump
 3. Figure 3a, Pump and Associated Hardware Details for Wells that receive a Single Speed Submersible Pump
 4. Figure 4, Well Pad and Wellhead Construction Diagram for Wells that receive a Variable Speed Submersible Pump
 4. Figure 4a, Pump and Associated Hardware Details for wells that receive a Variable Speed Submersible Pump
 5. Figure 5, Well Point Construction Diagram
-

Attachment 1 Boxing of SRS Drill Cores

1. Core boxes shall be used to cover a ten (10) foot interval of depth with the lost recovery zones represented by an empty space. The depths should always start and end on even 10 foot intervals.
2. The core should be handled as carefully as possible so as to minimize disruption.
3. The core shall be wrapped in a polyethylene sleeve or bag with the ends turned under in order to minimize moisture loss and disturbance.
4. The core shall be placed in the core box as diagrammed below.

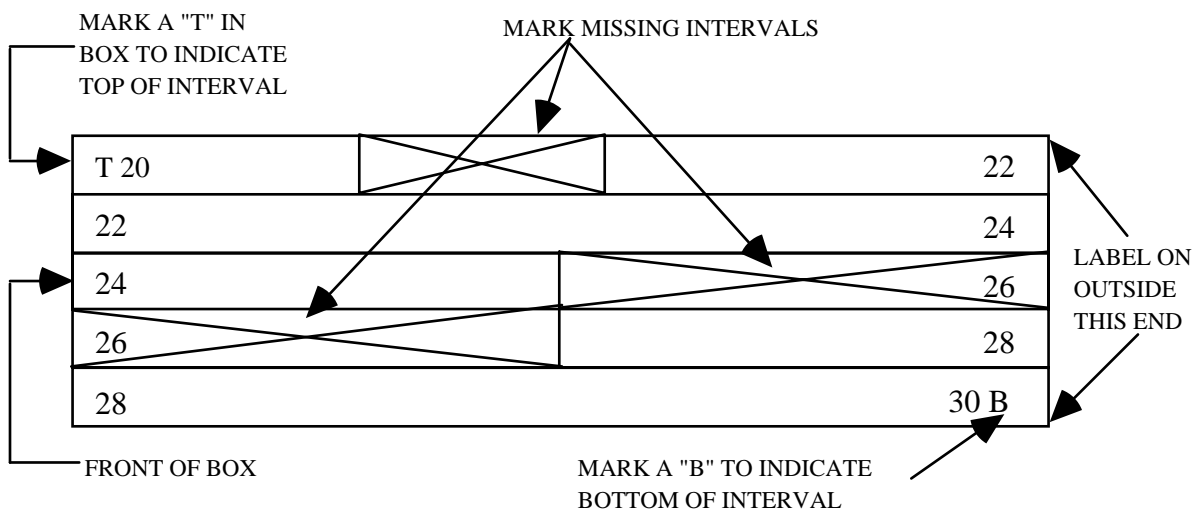

5. **MARK** the inside top of the box as indicated below.

Run #	From/To	Cored/Rec	% Rec	Comments

LABEL ON OUTSIDE THIS END

6. **MARK** front end of box cover as indicated on core box.

Attachment 2 Figure 1, Piezometer and Monitoring Well Construction Diagram

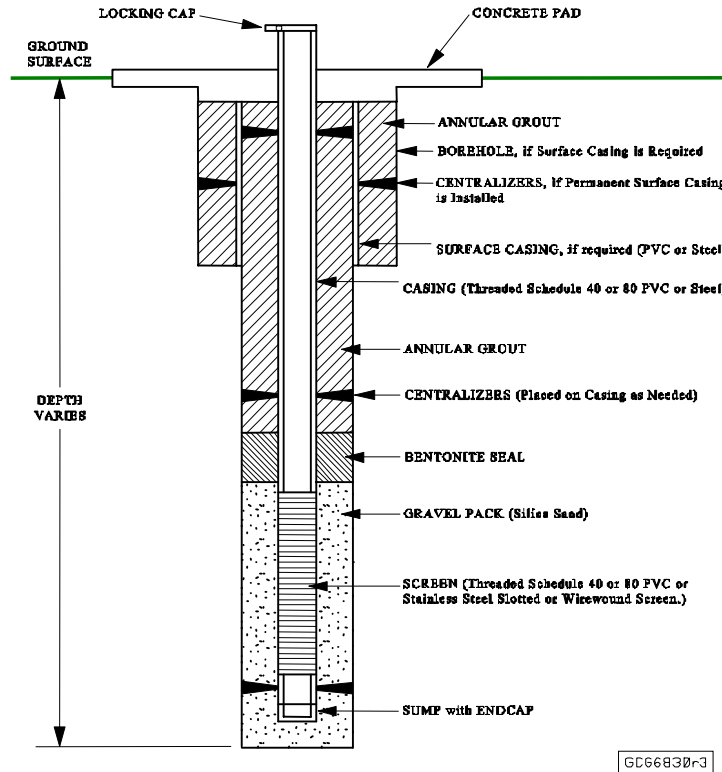
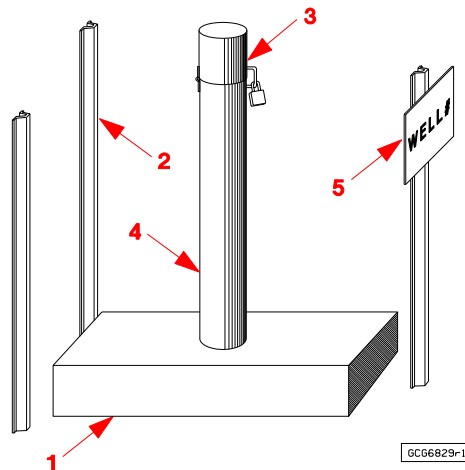
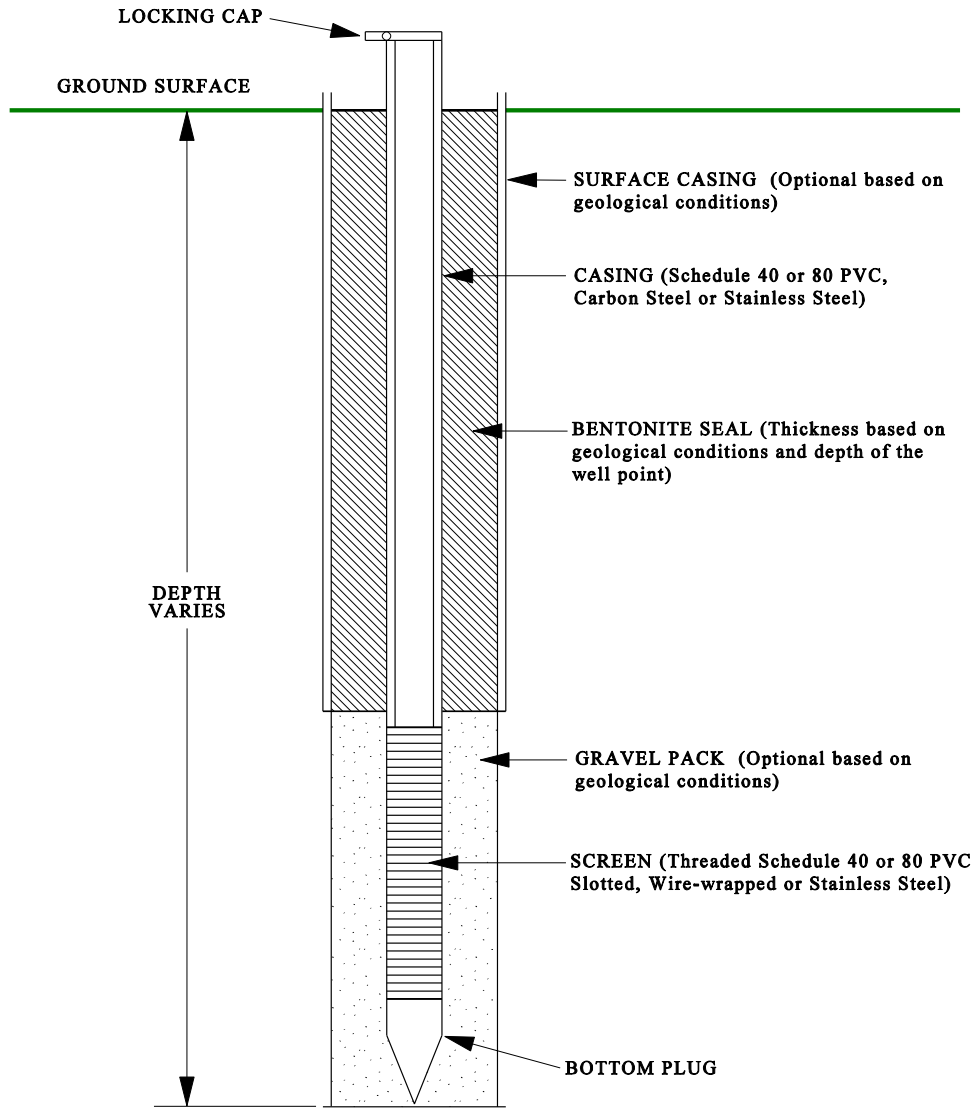

Figure 2, Piezometer Pad Construction Diagram



Attachment 5 Figure 5, Well Point Construction Diagram



GCG6831