

CHG. LET.	DESCRIPTION	DATE	BY	APP.	CHG. NO.
A	CHANGED LOCATION OF EVACUATION TUBE WELD	12/3/60	DF		447
B	ADDED NOTES	1/30/61	DF		514
C	NOTE 1 .020 DEPTH W/AS .035 ADDED NOTE 4	7/18/61	DF	JH	641

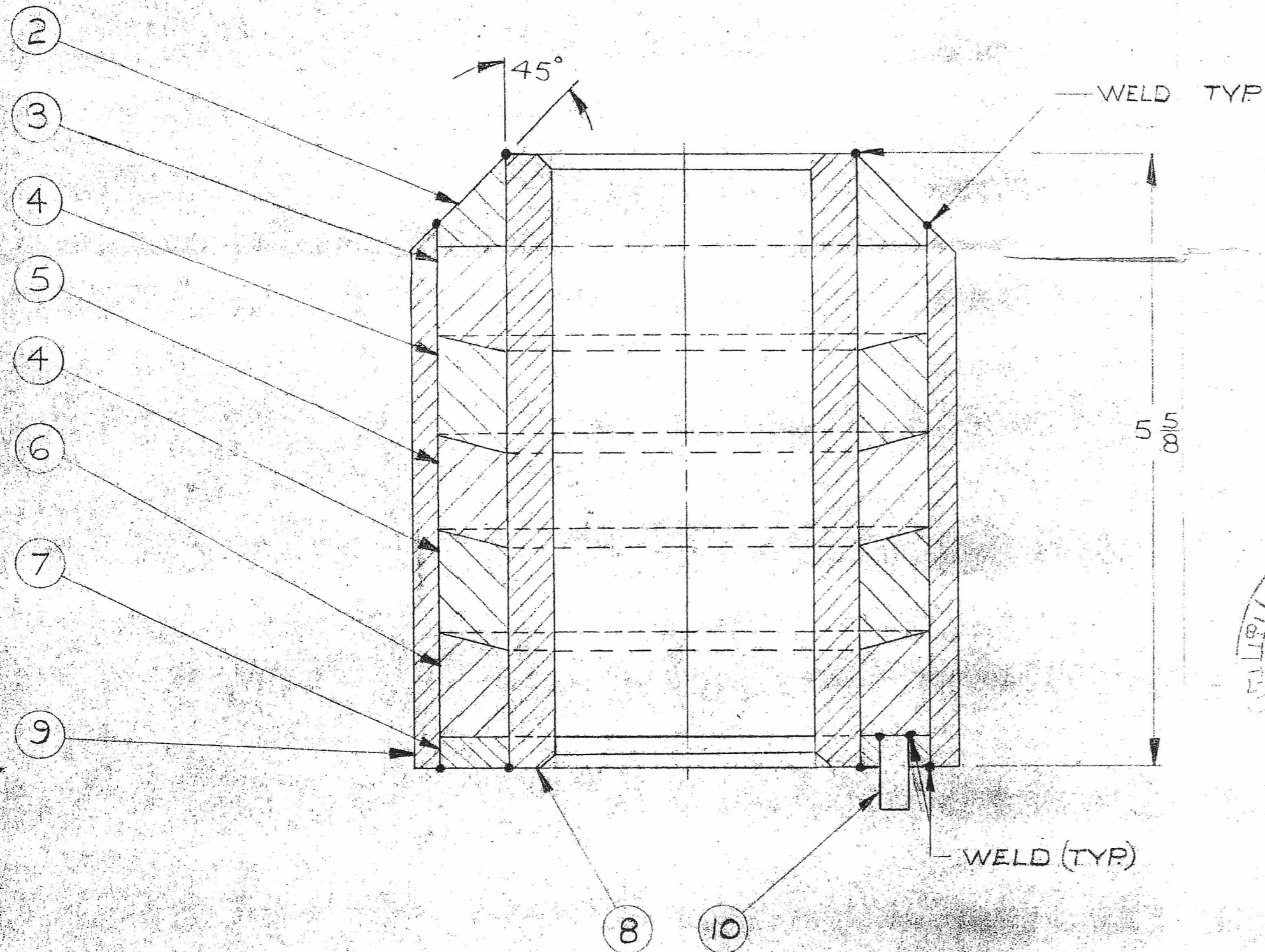
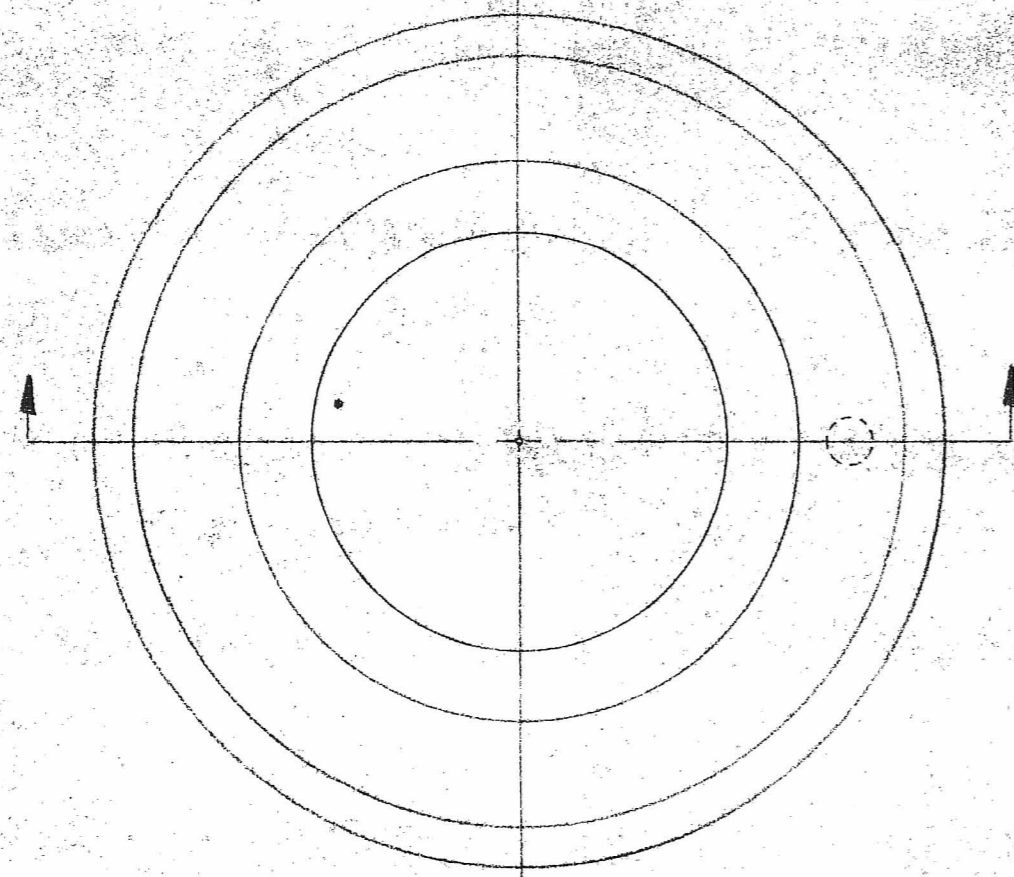

DOCKET NO. 70-139
FOR DIV OF COMPLIANCE

NOTES

1. INNER & OUTER CLADDING SURFACES (ID & OD) OF COMPOSITE BILLET MUST BE FREE OF ALL INCLUSIONS, THERE MUST BE NO SHARP CORNERED, PITS, DEPRESSIONS, SCRATCHES, OR GOUGES W/A DEPTH IN EXCESS OF .005, ANY PIT, DEPRESSIONS SCRATCH OR GOUGE IN EXCESS OF .005 MUST BE BLENDED INTO THE SURFACE TO REMOVE THE SHARP EDGES, MAX. DEPTH .020
2. THE COMPOSITE BILLET MUST BE FREE OF ALL OIL & FOREIGN CONTAMINANTS
3. THE COMPOSITE BILLET MUST BE VACUUM TIGHT
4. WELDS MUST NOT PROJECT ABOVE SURFACE



1	10	1113-31	EVACUATION TUBE
1	9	1113-22	OUTER CLAD
1	8	1113-21	INNER CLAD
1	7	1113-20	END SEAL
1	6	1113-19	REAR SPACER
1	5	1113-18	CENTER SPACER
2	4	1113-17	FUEL RING
1	3	1113-16	FRONT SPACER
1	2	1113-15	NOSE RING
X	1	1113-5	COMPOSITE BILLET ASS'Y TYPE II

G-2 QUANTITY	G-1 ITEM NO.	DRAWING NO.	DESCRIPTION	PROJECT NO.	USED ON ASS'Y
			APPROVED	DATE	FINISH & SPECIFICATION
TOLERANCES UNLESS OTHERWISE SPECIFIED			DRAWN	5/29/60	TITLE
DECIMAL	± .005		CHECKED		COMPOSITE BILLET ASS'Y TYPE II
FRACTIONAL	± 1/64"		APPROVED		MATERIAL & SPECIFICATION
ANGULAR	± 1/2°				
BREAK ALL SHARP EDGES			D. E. MAKEPEACE DIVISION		SCALE
REMOVE ALL BURRS			ATTLEBORO, MASS.		1/1
			SIZE	DRAWING NO.	REV.
			C	1113-5	C

D-01