

Contents

8A QUANTIFICATION OF THE LEVEL 2 PRA MODEL 8A-1

8A.1 Binning of Level 1 Results..... 8A-1

8A.2 Integration of the single top Level 2 PRA Model..... 8A-3

8A.2.1 Debris is Successfully Cooled (BI_FN)..... 8A-3

8A.2.2 GDCS Deluge Supply to BiMAC Successful (BI_SP)..... 8A-4

8A.2.3 Containment Isolation System (CIS) 8A-4

8A.2.4 Containment Intact / Insignificant DCH (DCH_DAM)..... 8A-4

8A.2.5 Pedestal Intact (EVE_DAM) 8A-4

8A.2.6 Water Level Prior to RPV Failure (LD_LVL) – (Deleted)..... 8A-5

8A.2.7 Reactor Coolant Boundary Intact (RCB_I)..... 8A-5

8A.2.8 Vapor Suppression Function (VB)..... 8A-5

8A.2.9 Vent Operation (VT)..... 8A-5

8A.2.10 Containment Heat Removal (W1, Short Term: <24 Hours)..... 8A-5

8A.2.11 Containment Heat Removal (W2, Long Term: <24 Hours) 8A-5

8A.3 Quantification of the Integrated Model..... 8A-5

List of Tables

Table 8A-1 Level 1 Sequence Bin Assignments 8A-7

Table 8A-2 Level 2 Results by Sequence 8A-10

Table 8A-3 Level 2 End State Frequencies* 8A-12

List of Illustrations

Figure 8A-1. Class I with Low Drywell Water Level CET 8A-13

Figure 8A-2. Class I with Medium Drywell Water Level CET..... 8A-14

Figure 8A-3. Class I with High Drywell Water Level..... 8A-15

Figure 8A-4. Class III with Low Drywell Water Level CET 8A-16

Figure 8A-5. Class IV with Low Drywell Water Level CET 8A-17

Figure 8A-6. Class IV with Medium Drywell Water Level CET 8A-18

Figure 8A-7. Class IV with High Drywell Water Level CET 8A-19

Figure 8A-8. Level 2 Fault Trees..... 8A-20

8A QUANTIFICATION OF THE LEVEL 2 PRA MODEL

The purpose of this appendix is to present the quantification of the Level 2 PRA. The results are used to determine the conditional containment failure probability (CCFP) and to calculate the frequencies of the various release categories used in the Level 3 PRA.

The CETs used for the Level 2 PRA analysis and described in Section 8 are logically equivalent to the combination of containment phenomenology event trees (CPET) and containment system event trees (CSET) used in the Section 21 discussion. In Section 21, separation of the two trees allowed a more clear distinction between the two analyses; a single, combined CET simplifies the quantification of the Level 2 PRA itself.

The containment response to phenomenological effects is described in Section 21.1 and the Containment Event Tree (CET) structure is described in Section 8.2. This structure was appended to the Level 1 full power, internal events event trees to determine the frequencies of the end states shown on the CETs. In this manner, the total CDF is mapped into appropriate Level 2 end states.

8A.1 BINNING OF LEVEL 1 RESULTS

In order to provide inputs to the CETs, the Level 1 accident sequences are sorted into Level 1 accident class bins. These were used to determine the appropriate phenomenology to consider in the CETs. To address containment susceptibility to steam explosions the Class I and Class IV accident sequences were further divided into bins that specify the water level in the containment at the time of vessel breach.

The Level 1 sequence bins were then used as the initiators to the Level 2 event trees. Effectively, the integrated model is a combination of both the Level 1 and Level 2 PRA models. As such, all initiator impact is preserved throughout the quantification and no special treatment is required for Loss of Preferred Power (LOPP) scenarios.

Table 8A-1 shows the subclass and bin assignment of the sequences above the Level 1 truncation value.

- Class I

In these cases, core damage occurs when the RPV is at low pressure. All of these sequences remain at low pressure in the RPV through the time of vessel breach.

The key information needed for the CET is the water level in the lower drywell at the time of vessel breach. If the water is above 1.5 m, failure of the pedestal due to steam explosion cannot be excluded, and therefore is conservatively assumed to occur. If the water level is between 0.7 m and 1.5 m, there is the possibility of a steam explosion but failure of the pedestal is physically unreasonable. Water level below 0.7 m does not present conditions that support a steam explosion. The criteria for qualitatively determining the water level are presented in Section 7.2.5.

The following subclasses are defined for quantification:

- Subclass I_LD Vessel failure occurs at low pressure (<1 MPa),
water level in containment is LOW or DRY
- Subclass I_M Vessel failure occurs at low pressure (<1 MPa),
water level in containment is MEDIUM
- Subclass I_H Vessel failure occurs at low pressure (<1 MPa),
water level in containment is HIGH

- Class II

As Class II sequences are defined by containment failure preceding core damage, they are not treated in the containment analysis. However, Class II sequences are binned into individual release categories according to their failure mode. For example, all Class II-b sequences are binned as Filtered Release (FR) releases because the wetwell vent is used as a mitigating system to core damage. Class II-a sequences are binned between OPW1, OPW2, and OPVB release categories according to system failures. Class II sequences are included in the release frequency results, but are not included as an input to the offsite dose calculation because core damage does not occur within 72 hours of accident initiation.

- Class III

In these cases, core damage occurs when the RPV is at high pressure. Water level information is not needed because the high-pressure melt ejection is not subject to the EVE phenomenon.

No additional information is needed for the quantification.

The following subclasses are defined for quantification:

- Subclass III_LD Vessel failure occurs at high pressure (>1 MPA)

- Class IV

In these cases, core damage sequences are initiated by a failure to reduce reactivity in the core. By the time that the core uncovers, however, the power is essentially shut down due to lack of moderator. The principle difference between these sequences and the Class I or III is the amount of energy transferred to the containment prior to vessel breach. The excess energy is not enough to change the key physics involved in containment failure, so the class can be treated just like the previously defined classes. In the ESBWR Level 1, all Class IV sequences above the truncation limit have depressurization available throughout the sequences, so operators are assumed to be guided to depressurize once core damage is imminent; core damage is assumed to occur when the RPV is at low pressure. All of these sequences remain at low pressure in the RPV through the time of vessel breach. Therefore, the Class IV sequences use the same quantification model as the Class I.

The following subclasses are defined for quantification:

- Subclass IV_LD Water level in containment is LOW
- Subclass IV_M Water level in containment is MEDIUM
- Subclass IV_H Water level in containment is HIGH

Class IV is retained separately because the timing of key events is somewhat faster than the Class I events.

- Class V

These are cases where core damage occurs with the RPV open to the environment. No containment event trees are needed. All of these sequences are assigned to the release category of BOC.

8A.2 INTEGRATION OF THE SINGLE TOP LEVEL 2 PRA MODEL

The single-top Level 2 PRA was created with the same basic methodology as the Level 1 model. The key difference is that in the Level 1, each initiator is a basic event with an assigned frequency. In the Level 2, the “initiator” is actually a gate under which the appropriate Level 1 sequences are binned.

To represent the nodes in each of the Level 2 event trees there is either a fault tree or a basic event with a point estimate to represent phenomenological effects. The fault trees may be completely independent of Level 1 sequences (such as the GDCS deluge system), or contain dependencies (such as short term CHR). Integrating the Level 2 PRA with the Level 1 as a single, one-time quantification model allows all dependencies and initiator impact to be correctly reflected in the results.

The Level 2 model integration is as follows:

- The baseline, at-power Level 1 PRA was merged with the Level 1 sequence-binning logic and the new Level 2 fault trees. The gates in the binning logic act as Level 2 event tree initiators, and the fault trees correspond to the nodes in the Level 2 event trees.
- All sequences were imported from the Level 2 event trees. This completes the link from Level 1 initiator to Level 1 sequence, Level 2 initiator, and Level 2 sequence and release category.
- Finally, the Level 2 sequences were merged with the top logic tree for the Level 2 PRA. This top logic tree allows a one-time quantification of the integrated Level 1 / Level 2 model. Many benefits result from the one-top quantification, two of which are decreased quantification time and easily accessible, globally relevant importance measures.

The functions and bases for the Level 2 fault trees are explained in the following sections.

8A.2.1 Debris is Successfully Cooled (BI_FN)

This node is only asked following successful operation of the deluge system. Section 21 identifies the failure of this function as physically unreasonable given successful operation of deluge. This would imply a node probability of less than 10^{-3} for BI_FN, but because the design optimization of the BiMAC has not been completed, the ESBWR PRA assigns a conservative

value of 10^{-2} to this node. This value is considered conservative based on the analysis in Section 21.5 and the possibility that the core would be sufficiently spread on the drywell floor to be cooled solely by the overlying pool of water from the deluge system.

8A.2.2 GDCS Deluge Supply to BiMAC Successful (BI_SP)

A complete fault tree analysis was done of the GDCS deluge system. The deluge system is completely independent from all other plant systems and, as a result, all Level 1 sequences. The actuation system is powered by stand-alone batteries and managed by deluge-specific powered logic cabinets (PLCs). There are four main deluge lines, one each from GDCS pools A and D, and two from GDCS pool BC. Each main line forks into three injection lines for a total of 12; each injection line has one squib valve. Successful cooling requires 6 of 12 injection lines.

8A.2.3 Containment Isolation System (CIS)

Appendix 8C provides a screening of potential containment penetrations that may need to be isolated in a severe accident. The Main Steam lines and Feedwater lines were identified as requiring isolation once core damage occurs. To account for these lines, a fault tree was developed for the CIS node to represent the isolation function. Dependencies on the Level 1 model for software function and hardware failures are accounted for in the integrated model.

The placement of node CIS after the phenomenological release nodes in the CETs does not have a significant effect on the Level 2 release category frequency results. The potential for a more severe phenomenological release because of failed containment isolation is screened as below truncation. The effect of increasing the BYP release frequency by placing the CIS node immediately after the initiator in the CET is considered with a sensitivity study in Section 11.

8A.2.4 Containment Intact / Insignificant DCH (DCH_DAM)

Section 21.3 provides the justification for the failure of this function being physically unreasonable. As such, the baseline Level 2 PRA does not consider DCH as a credible failure mode. However, a Section 11 sensitivity study quantifies the potential for DCH by assigning the phenomenon a conservative value of 10^{-3} for all subclasses that experience RPV failure at high pressure.

8A.2.5 Pedestal Intact (EVE_DAM)

Section 21.4 provides the justification for the failure of this function being physically unreasonable in cases where the LDW water level is less than 1.5 m but greater than 0.7 m prior to vessel breach. As such, the baseline Level 2 PRA does not consider EVE from medium water levels to be a credible failure mode. This function will only be asked in the “medium” water level event trees in a Section 11 sensitivity study in which a conservative value of 10^{-3} is assigned for containment failure.

8A.2.6 Water Level Prior to RPV Failure (LD_LVL) – (Deleted)**8A.2.7 Reactor Coolant Boundary Intact (RCB_I)**

This branch was not used in the CET quantification. It was identified in Section 21.2 as a “splinter”, which means that it is uncertain which path would be followed in any given sequence and a meaningful probability cannot be assigned to the branch. These are treated by solving both paths independently and taking the maximum of the results. As discussed in Section 21.2, the path leading to an intact Reactor Coolant Pressure Boundary is more conservative and therefore included in the results.

8A.2.8 Vapor Suppression Function (VB)

This node was modeled using the fault tree from the Level 1 analysis for vapor suppression, “DS-TOPVB”. The success criteria are 1 of 3 vacuum breakers must open to break a wetwell to drywell vacuum, and 2 of 3 vacuum breakers must remain closed for vapor suppression.

8A.2.9 Vent Operation (VT)

Air-operated vent valve opening is modeled using the same functional top gate as in the Level 1 analysis: WV-TOPVENT. Re-close of the vent valves is not modeled; the release is assumed to continue once initiated. This captures the function dependency on support systems and Level 1 initiators such as instrument air, the Q-DCIS, and DC power supply. These suppression pool vent valves are opened by remote manual actuation from the control room upon high DW pressure. Using the Level 1 fault tree is conservative because the manual action from Level 1 is based on a time much less than 24 hours. In the Level 2 accident sequence, the operator would have greater than 24 hours, but no operator venting failures appear in the results so the conservatism has negligible impact.

8A.2.10 Containment Heat Removal (W1, Short Term: <24 Hours)

This node is represented by a fault tree with a combination of functions from the Level 1 PRA. The success criteria are that either PCCS, which requires leak tight vacuum breakers, or the suppression pool cooling mode of FAPCS can remove heat in the short term. The dependency of the suppression pool cooling mode of FAPCS on preferred power is captured by the initiator impact in the system-level fault trees.

8A.2.11 Containment Heat Removal (W2, Long Term: <24 Hours)

This node is identical to the W1 node except that long-term makeup to the PCCS pools is required for PCCS to function. ICS/PCCS pool make-up can be provided automatically by the dryer/separators storage pool cross-connect valves or manually by the Fire Protection System.

8A.3 QUANTIFICATION OF THE INTEGRATED MODEL

The single top Level 2 model was quantified at a truncation of 1E-15. The integrated model includes various markers, such as release category and Level 2 sequence, which make the results more versatile for post-processing. The Level 2 event trees are shown in Figures 8A-1 through 8A-7; all of the quantified sequence end state frequencies are shown in Table 8A-3. For each

release category, all of the relevant sequence frequencies were totaled to determine the total release category frequency as input to the offsite dose calculation.

To make the sum of the Level 2 release category frequencies match the Level 1 CDF, TSL was calculated by subtracting the total of all non-TSL release categories from the core damage frequency. This conservatively accounts for the small frequency increase associated with the approximations in the quantification process by only reducing the frequency of the “success” path, TSL.

Table 8A-1
Level 1 Sequence Bin Assignments

Acc. Sequence	Initiating Event	CDF [1/yr]	Level 1 Class	Level 2 Event Tree	LDW Water Level
T-IORV063	MS-T-IORV	1.79E-09	cdi	I_LD	Low
T-FDW050	%T-FDW	1.12E-09	cdi	I_LD	Low
LL-S-FDWB045	%LL-S-FDWB	5.23E-10	cdi	I_H	High
T-IORV017	MS-T-IORV	4.92E-10	cdi	I_LD	Low
T-LOPP050	T-LOPP	3.64E-10	cdi	I_LD	Low
T-GEN067	T-GEN	1.52E-10	cdi	I_LD	Low
T-FDW060	%T-FDW	8.62E-11	cdi	I_LD	Low
BOC-FDWA027	%BOC-FDWA	7.72E-11	cdi	I_LD	Low
ML-L011	%ML-L	5.39E-11	cdi	I_M	Medium
T-GEN021	T-GEN	4.43E-11	cdi	I_LD	Low
LL-S-FDWA013	%LL-S-FDWA	4.25E-11	cdi	I_H	High
SL-S017	SL-S	2.84E-11	cdi	I_LD	Low
T-LOPP060	T-LOPP	2.73E-11	cdi	I_LD	Low
AT-T-SW004	AT-T-SW	2.62E-11	cdi	I_LD	Low
BOC-FDWB053	%BOC-FDWB	2.46E-11	cdi	I_LD	Low
SL-S063	SL-S	2.35E-11	cdi	I_LD	Low
AT-LOCA005	AT-LOCA	1.98E-11	cdi	I_M	Medium
RVR-014	RVR	1.64E-11	cdi	I_H	High
T-SW037	%T-SW	1.41E-11	cdi	I_LD	Low
LL-S047	LL-S	1.25E-11	cdi	I_LD	Low
BOC-FDWB020	%BOC-FDWB	7.41E-12	cdi	I_LD	Low
SL-L022	%SL-L	4.24E-12	cdi	I_M	Medium
T-SW010	%T-SW	4.23E-12	cdi	I_LD	Low
LL-S049	LL-S	4.16E-12	cdi	I_LD	Low
SL-L068	%SL-L	3.38E-12	cdi	I_M	Medium
BOC-FDWB019	%BOC-FDWB	5.34E-13	cdi	I_LD	Low
BOC-FDWB036	%BOC-FDWB	4.1E-13	cdi	I_LD	Low
T-LOPP033	T-LOPP	3.39E-13	cdi	I_LD	Low
T-SW009	%T-SW	2.35E-13	cdi	I_LD	Low
T-SW029	%T-SW	2.35E-13	cdi	I_LD	Low
AT-T-GEN020	AT-T-GEN	1.33E-11	cdii-a	N/A	
LL-S-FDWB046	%LL-S-FDWB	5.23E-12	cdii-a	N/A	
AT-T-GEN016	AT-T-GEN	4.81E-12	cdii-a	N/A	
AT-T-IORV004	AT-T-IORV	1.31E-12	cdii-a	N/A	
T-IORV064	MS-T-IORV	1.17E-12	cdii-a	N/A	
T-IORV013	MS-T-IORV	2.59E-13	cdii-a	N/A	
T-IORV027	MS-T-IORV	2.59E-13	cdii-a	N/A	
AT-T-IORV008	AT-T-IORV	1.88E-13	cdii-a	N/A	
AT-T-GEN021	AT-T-GEN	7.46E-10	cdiii	III_LD	

Table 8A-1
Level 1 Sequence Bin Assignments

Acc. Sequence	Initiating Event	CDF [/yr]	Level 1 Class	Level 2 Event Tree	LDW Water Level
T-IORV018	MS-T-IORV	7.26E-10	cdiii	III_LD	
T-IORV065	MS-T-IORV	5.75E-10	cdiii	III_LD	
AT-T-LOPP013	AT-T-LOPP	4.46E-10	cdiii	III_LD	
AT-T-FDW013	AT-T-FDW	3.4E-10	cdiii	III_LD	
T-FDW061	%T-FDW	3.13E-10	cdiii	III_LD	
AT-T-IORV009	AT-T-IORV	1.49E-10	cdiii	III_LD	
T-LOPP061	%T-SW	1.29E-10	cdiii	III_LD	
T-GEN022	T-GEN	6.45E-11	cdiii	III_LD	
T-GEN069	T-GEN	5.79E-11	cdiii	III_LD	
BOC-FDWB054	%BOC-FDWB	3.04E-11	cdiii	III_LD	
BOC-FDWA029	%BOC-FDWA	2.55E-11	cdiii	III_LD	
ML-L012	%ML-L	1.78E-11	cdiii	III_LD	
T-SW039	%T-SW	1.73E-11	cdiii	III_LD	
BOC-FDWB021	%BOC-FDWB	1.08E-11	cdiii	III_LD	
SL-S018	SL-S	8.26E-12	cdiii	III_LD	
SL-S065	SL-S	6.69E-12	cdiii	III_LD	
AT-T-GEN012	AT-T-GEN	6.31E-12	cdiii	III_LD	
T-SW011	%T-SW	6.09E-12	cdiii	III_LD	
AT-T-FDW008	AT-T-FDW	2.92E-12	cdiii	III_LD	
SL-L023	%SL-L	1.27E-12	cdiii	III_LD	
SL-L070	%SL-L	1.01E-12	cdiii	III_LD	
AT-T-LOPP008	AT-T-LOPP	8.45E-13	cdiii	III_LD	
AT-T-GEN023	AT-T-GEN	1.3E-09	cdiv	IV_LD	Low
AT-T-GEN026	AT-T-GEN	2.39E-10	cdiv	IV_LD	Low
AT-T-FDW015	AT-T-FDW	1.11E-10	cdiv	IV_LD	Low
LL-S050	LL-S	8.47E-11	cdiv	IV_LD	Low
AT-T-LOPP015	AT-T-LOPP	3.21E-11	cdiv	IV_LD	Low
AT-T-GEN024	AT-T-GEN	2.93E-11	cdiv	IV_LD	Low
AT-T-IORV011	AT-T-IORV	2.58E-11	cdiv	IV_LD	Low
ML-L014	%ML-L	1.89E-11	cdiv	IV_H	High
AT-T-IORV014	AT-T-IORV	4.27E-12	cdiv	IV_LD	Low
AT-T-FDW016	AT-T-FDW	2.53E-12	cdiv	IV_LD	Low
LL-S-FDWA016	%LL-S-FDWA	1.39E-12	cdiv	IV_H	High
LL-S-FDWB047	%LL-S-FDWB	1.39E-12	cdiv	IV_H	High
AT-T-SW006	AT-T-SW	7.75E-13	cdiv	IV_LD	Low
AT-T-IORV012	AT-T-IORV	5.31E-13	cdiv	IV_LD	Low
AT-LOCA012	AT-LOCA	5.06E-13	cdiv	IV_M	Medium
AT-T-LOPP016	AT-T-LOPP	4.66E-13	cdiv	IV_LD	Low
AT-T-GEN025	AT-T-GEN	1.4E-13	cdiv	IV_LD	Low
BOC-MS067	%BOC-MS	1.13E-13	cdiv	IV_LD	Low
ML-L013	%ML-L	7.11E-11	cdv	N/A	

Table 8A-1
Level 1 Sequence Bin Assignments

Acc. Sequence	Initiating Event	CDF [/yr]	Level 1 Class	Level 2 Event Tree	LDW Water Level
BOC-RWCU051	%BOC-RWCU	4.37E-11	cdv	N/A	
T-FDW052	%T-FDW	1.1E-11	cdv	N/A	
BOC-RWCU015	%BOC-RWCU	4.36E-12	cdv	N/A	
T-LOPP052	T-LOPP	3.29E-12	cdv	N/A	
BOC-RWCU049	%BOC-RWCU	1.23E-12	cdv	N/A	
BOC-FDWB105	%BOC-FDWB	6.21E-13	cdv	N/A	
BOC-FDWB103	%BOC-FDWB	1.64E-13	cdv	N/A	

Table 8A-2
Level 2 Results by Sequence

Sequence	Contribution	Frequency	Release Category	% Release Category
I_LD-01	4.010E-01	4.94E-09	TSL	
I_LD-02			FR1	
I_LD-03			OPW2	
I_LD-04			FR2	
I_LD-05			OPW1	
I_LD-06	6.350E-03	6E-12	OPVB	37.5740%
I_LD-07	2.150E-03	2E-12	BYP	3.5374%
I_LD-08	4.660E-02	4.3E-11	CCIW	43.5514%
I_LD-09	4.960E-04	ε	CCID	50.9764%
I_M-01	8.070E-03	1.00E-10	TSL	
I_M-02			FR1	
I_M-03			OPW2	
I_M-04			FR2	
I_M-05			OPW1	
I_M-06			OPVB	
I_M-07			BYP	
I_M-08	8.830E-04	1E-12	CCIW	0.8252%
I_M-09	3.110E-06	ε	CCID	0.3196%
I_M-10			EVE	
I_H-01	6.340E-01	5.88E-10	EVE	96.3526%
III_LD-01	3.670E-01	4.52E-09	TSL	
III_LD-02			FR1	
III_LD-03	2.970E-05	ε	OPW2	35.3993%
III_LD-04			FR2	
III_LD-05			OPW1	
III_LD-06			OPVB	
III_LD-07	3.840E-03	3E-12	BYP	6.3179%
III_LD-08	4.000E-02	3.7E-11	CCIW	37.3832%
III_LD-09	1.960E-04	ε	CCID	20.1439%
III_LD-10			DCH	
IV_LD-01	1.490E-01	1.83E-09	TSL	
IV_LD-02			FR1	
IV_LD-03			OPW2	
IV_LD-04			FR2	
IV_LD-05			OPW1	
IV_LD-06			OPVB	
IV_LD-07	1.870E-02	1.7E-11	BYP	30.7670%
IV_LD-08	1.980E-02	1.8E-11	CCIW	18.5047%
IV_LD-09	2.790E-04	ε	CCID	28.6742%

Table 8A-2
Level 2 Results by Sequence

Sequence	Contribution	Frequency	Release Category	% Release Category
IV_M-01	5.850E-05	1E-12	TSL	
IV_M-02			FR1	
IV_M-03			OPW2	
IV_M-04			FR2	
IV_M-05			OPW1	
IV_M-06			OPVB	
IV_M-07	6.470E-06	ϵ	BYP	0.0106%
IV_M-08	5.750E-06	ϵ	CCIW	0.0054%
IV_M-09			CCID	
IV_M-10			EVE	
IV_H-01	2.350E-02	2.2E-11	EVE	3.5714%

Table 8A-3
Level 2 End State Frequencies*

	I_LD	I_M	I_H	III_LD	IV_LD	IV_M	IV_H	II-a	II-b	V	Totals
TSL	4.9E-09	1E-10	-	4.5E-09	1.8E-09	ε	-	-	-	-	1.14E-08
FR			-				-	-	ε	-	ε
OPW2			-	ε			-	ε	-	-	ε
OPW1			-				-	3E-11	-	-	3E-11
OPVB	6E-12		-				-	1E-11	-	-	2E-11
BYP	2E-12		-	4E-12	2E-11	ε	-	-	-	-	2E-11
CCIW	4E-11	ε	-	4E-11	2E-11	ε	-	-	-	-	1E-10
CCID	5E-13	ε	-	ε	ε		-	-	-	-	ε
EVE	-		6E-10				2E-11	-	-	-	6E-10
DCH	-	-	-		-	-	-	-	-	-	0
BOC	-	-	-	-	-	-	-	-	-	1E-10	1E-10

* Note that these are not the final release category frequencies as reported in Section 8, Table 8.2-2. This table displays the raw quantification results, further post-processing such as adding bypass due to de-inerted operation is performed before the final results are complete.

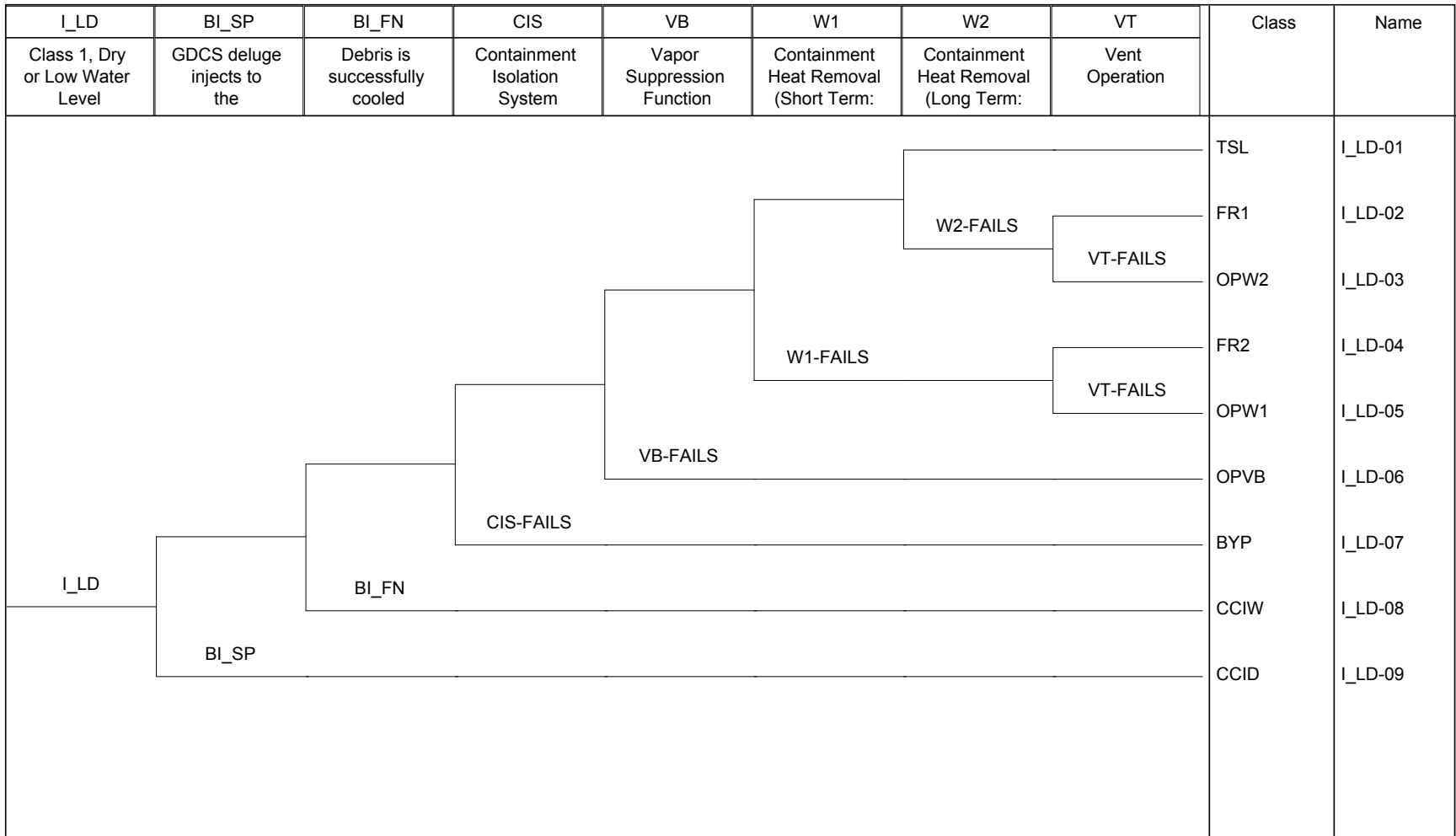

Figure 8A-1. Class I with Low Drywell Water Level CET

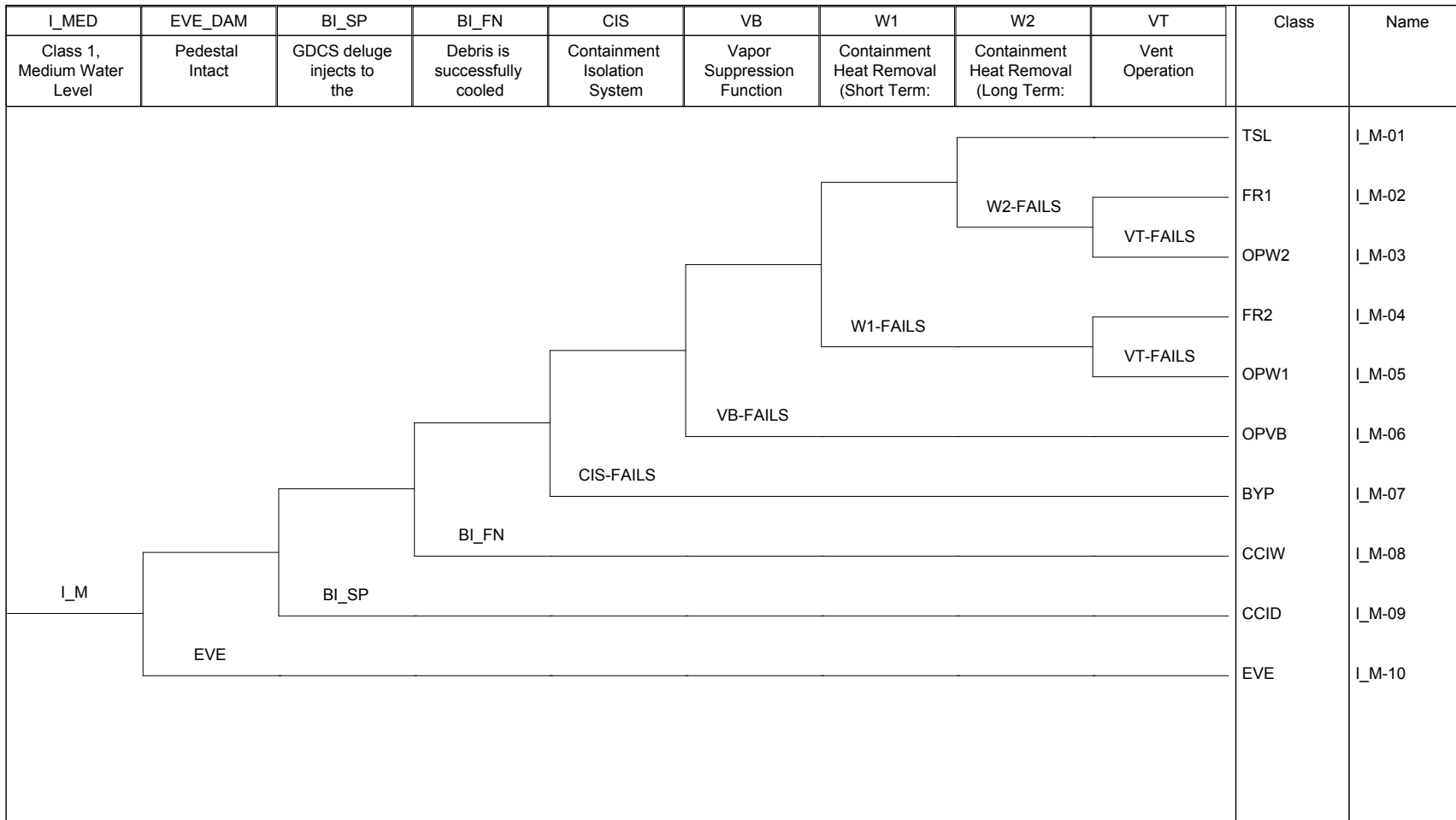

Figure 8A-2. Class I with Medium Drywell Water Level CET

I_HI	EVE_DAM	BI_SP	BI_FN	Class	Name
Class 1, High Water	Pedestal Intact	GDCS deluge injects to	Debris is successfully		
I_H				EVE	I_H-01

Figure 8A-3. Class I with High Drywell Water Level

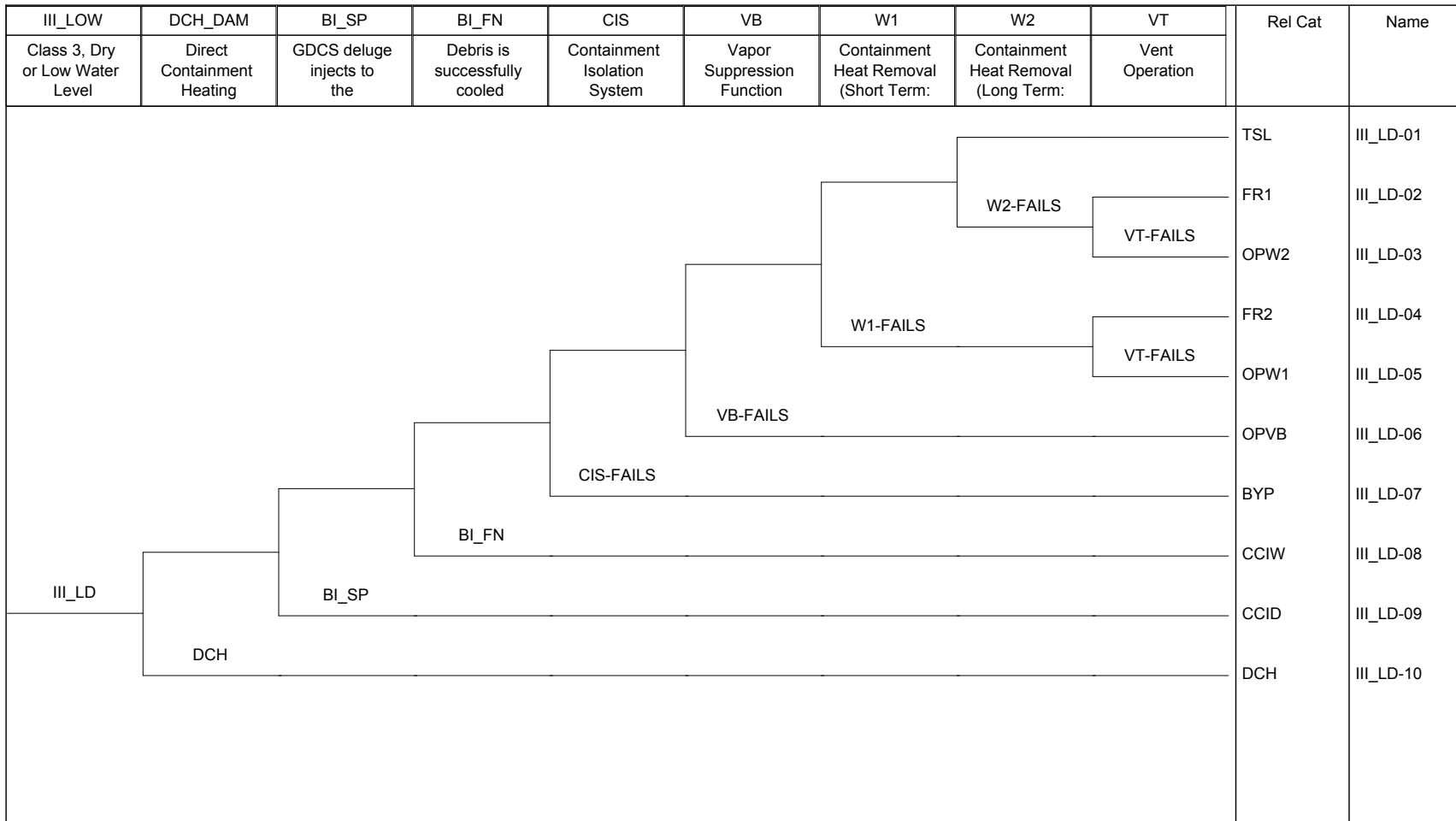

Figure 8A-4. Class III with Low Drywell Water Level CET

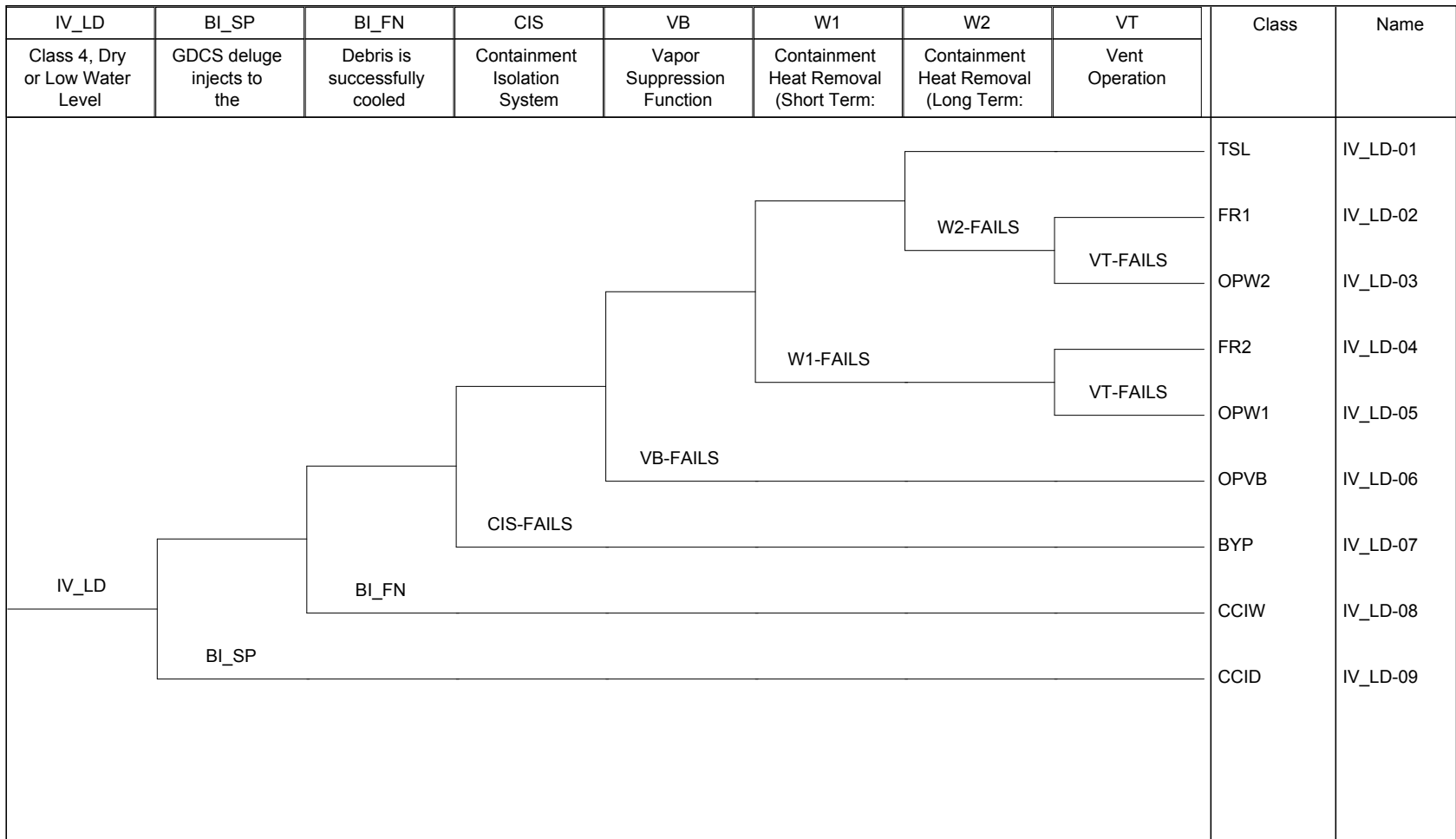

Figure 8A-5. Class IV with Low Drywell Water Level CET

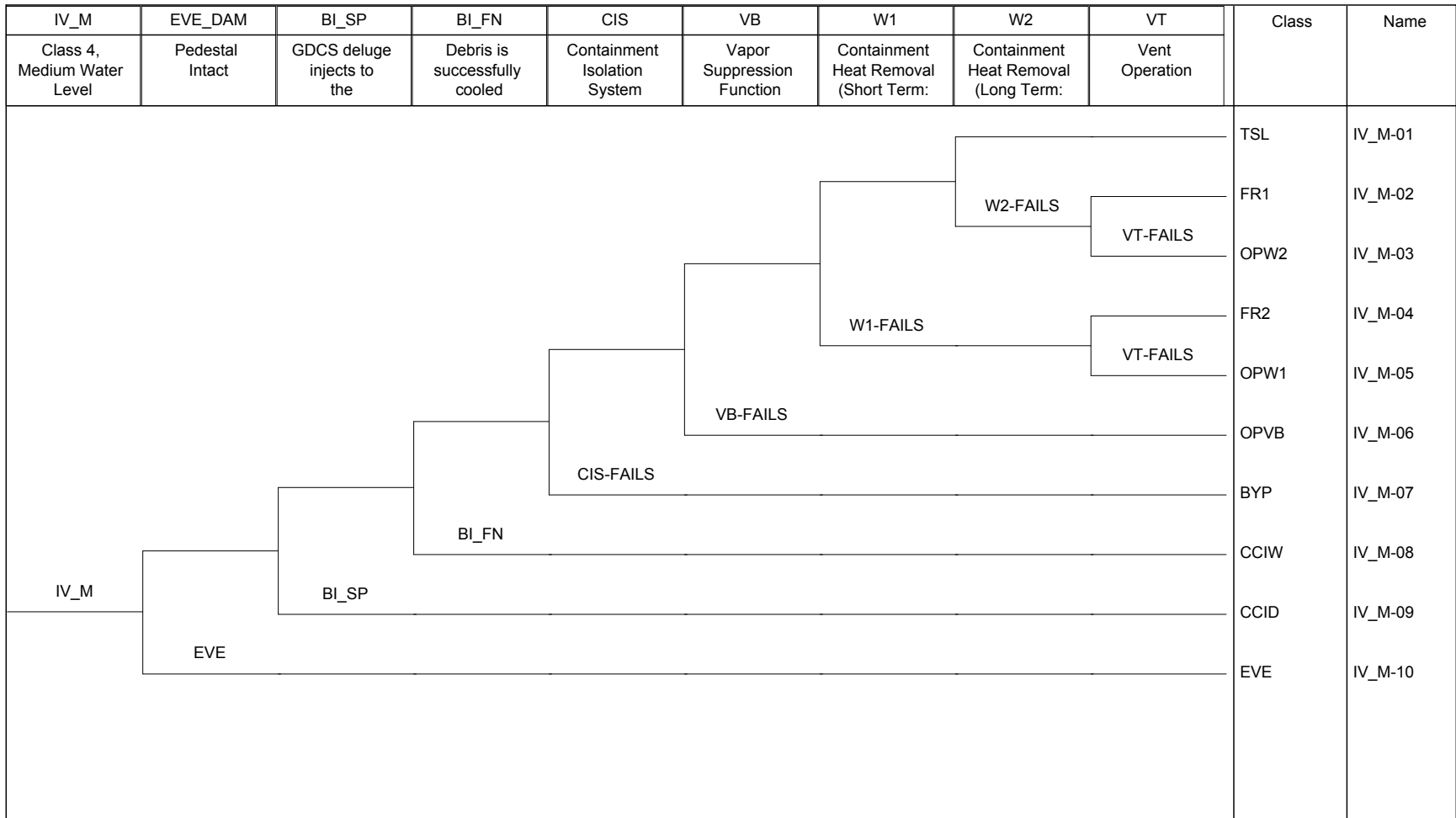

Figure 8A-6. Class IV with Medium Drywell Water Level CET

IV	EVE_DAM	BI_SP	BI_FN	CIS	VB	W1	W2	VT	Class	Name
Class 4, High Water Level	Pedestal Intact	GDCS deluge injects to the	Debris is successfully cooled	Containment Isolation System	Vapor Suppression Function	Containment Heat Removal (Short Term:	Containment Heat Removal (Long Term:	Vent Operation		
IV_H									EVE	IV_H-01

Figure 8A-7. Class IV with High Drywell Water Level CET

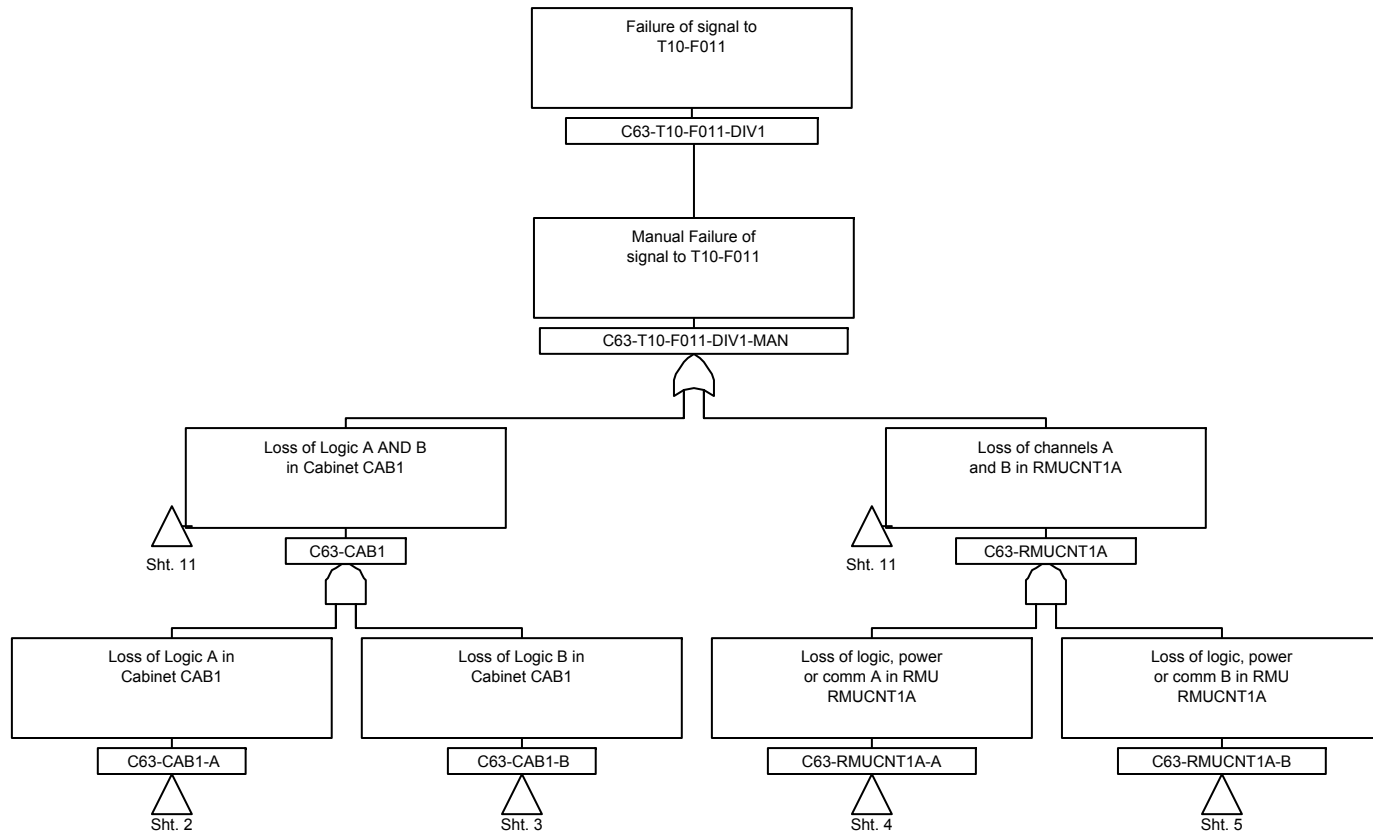

Figure 8A-8. Level 2 Fault Trees
Sheet 1 of 147

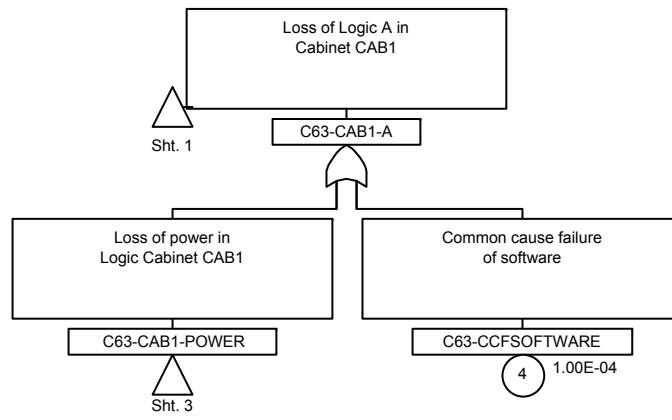

Figure 8A-8. Level 2 Fault Trees

Sheet 2 of 147

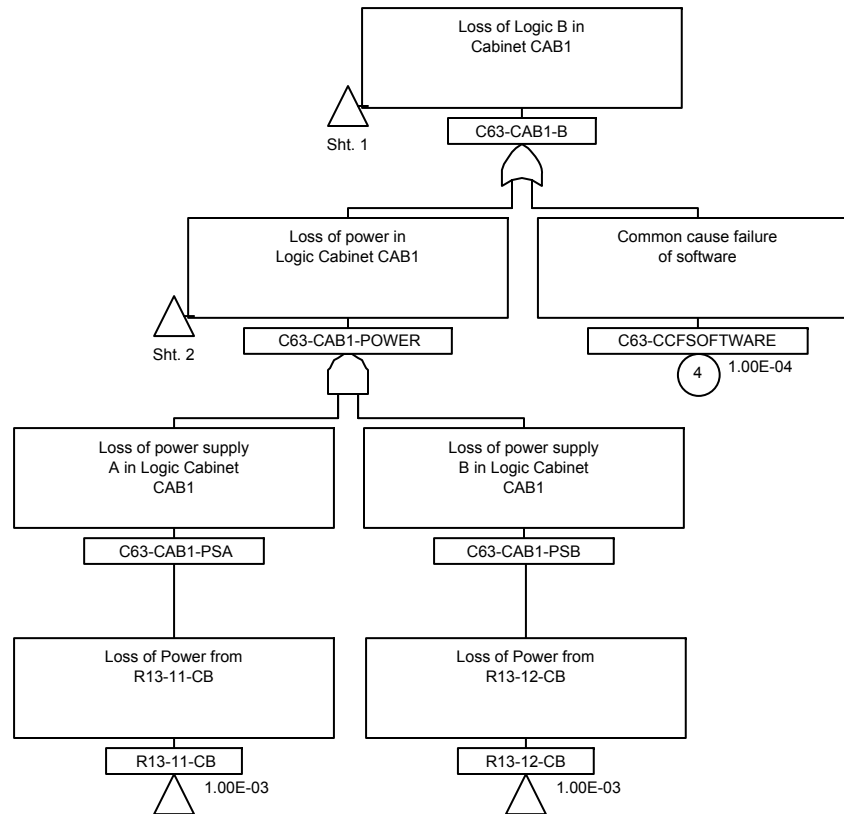

Figure 8A-8. Level 2 Fault Trees
Sheet 3 of 147

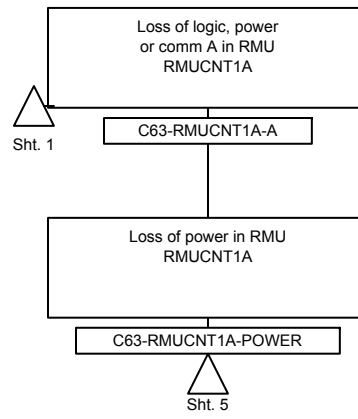

Figure 8A-8. Level 2 Fault Trees
Sheet 4 of 147

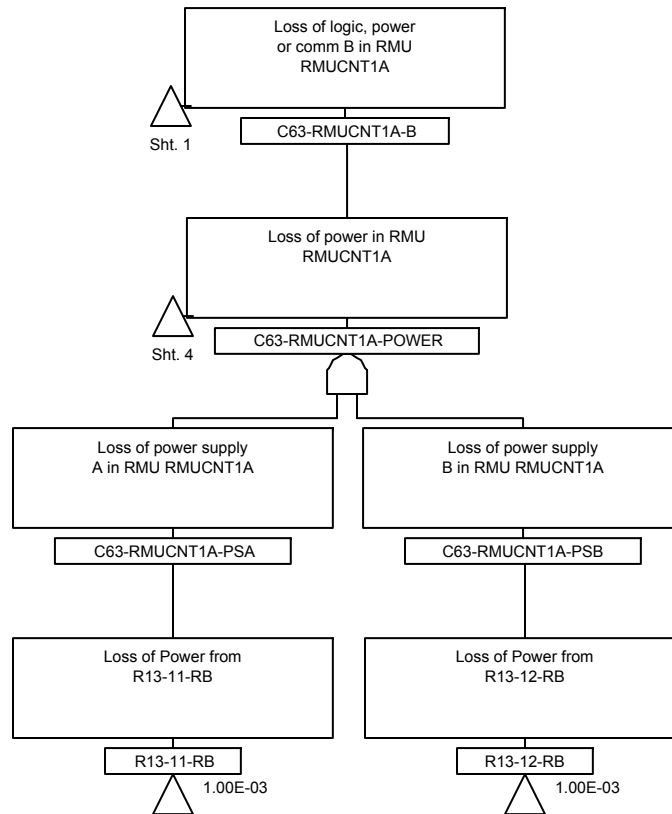

Figure 8A-8. Level 2 Fault Trees
Sheet 5 of 147

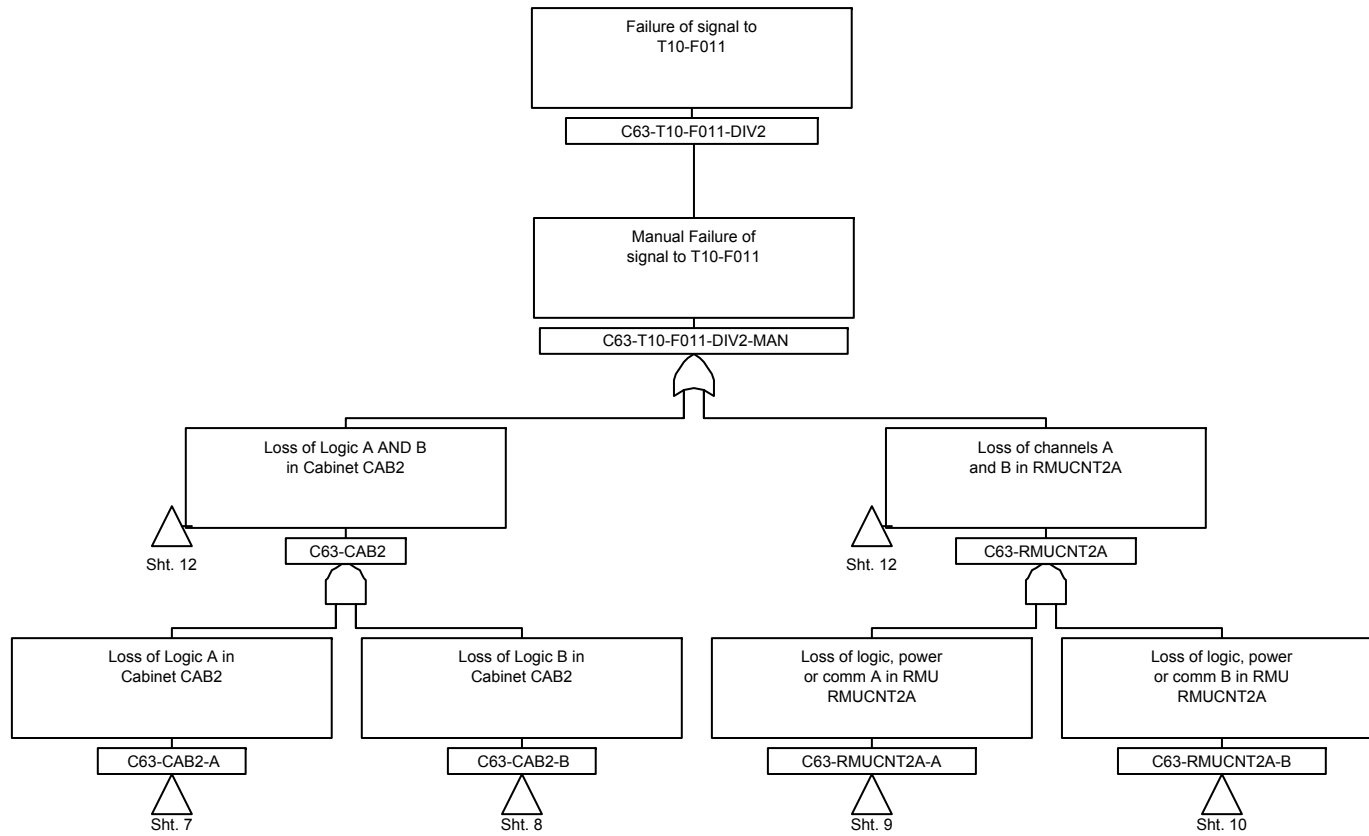

Figure 8A-8. Level 2 Fault Trees
Sheet 6 of 147

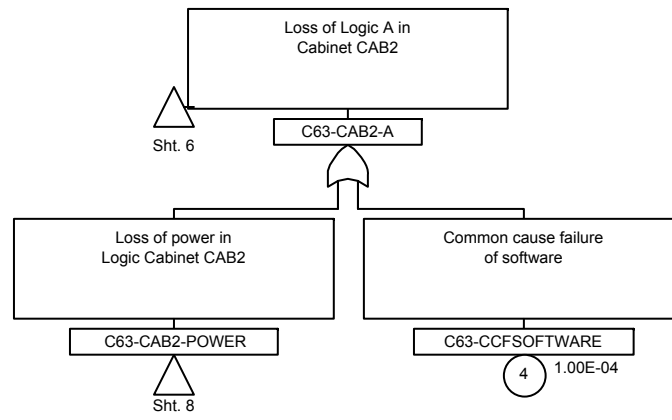

Figure 8A-8. Level 2 Fault Trees
Sheet 7 of 147

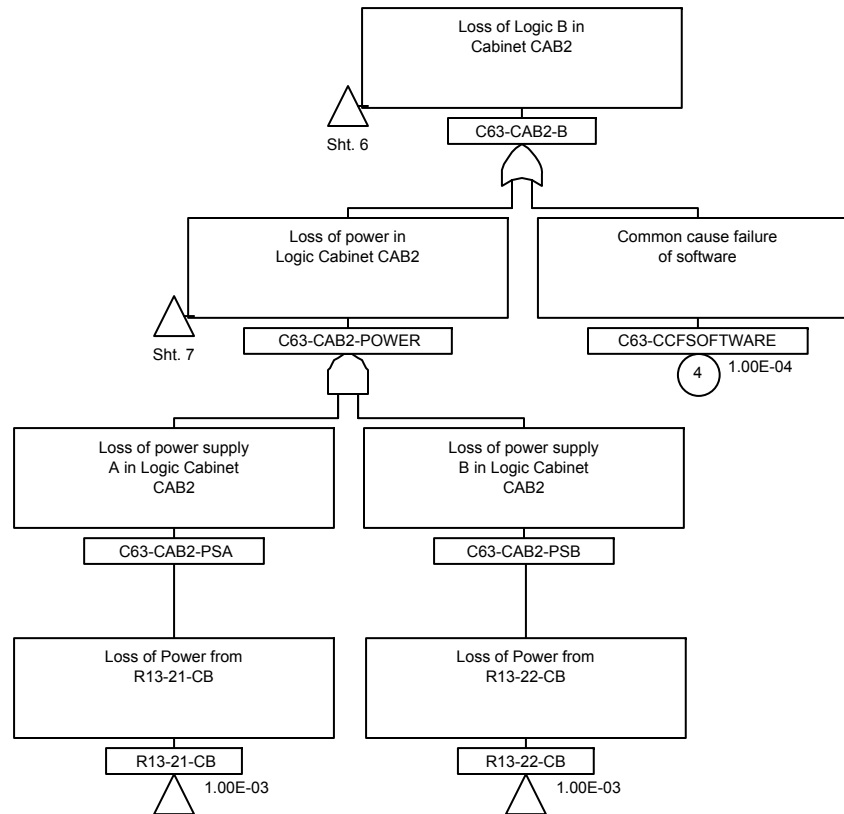

Figure 8A-8. Level 2 Fault Trees

Sheet 8 of 147

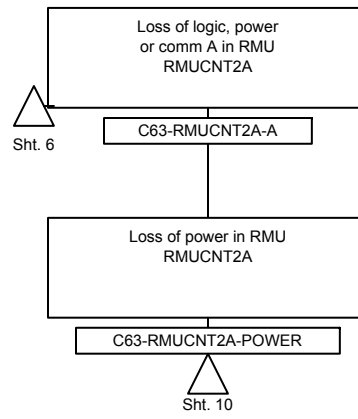

Figure 8A-8. Level 2 Fault Trees

Sheet 9 of 147

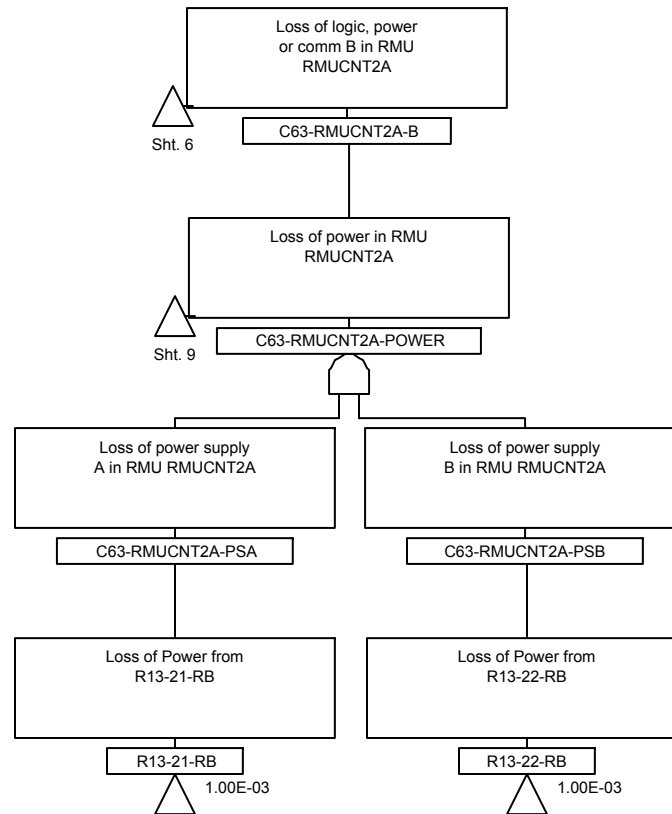

Figure 8A-8. Level 2 Fault Trees

Sheet 10 of 147

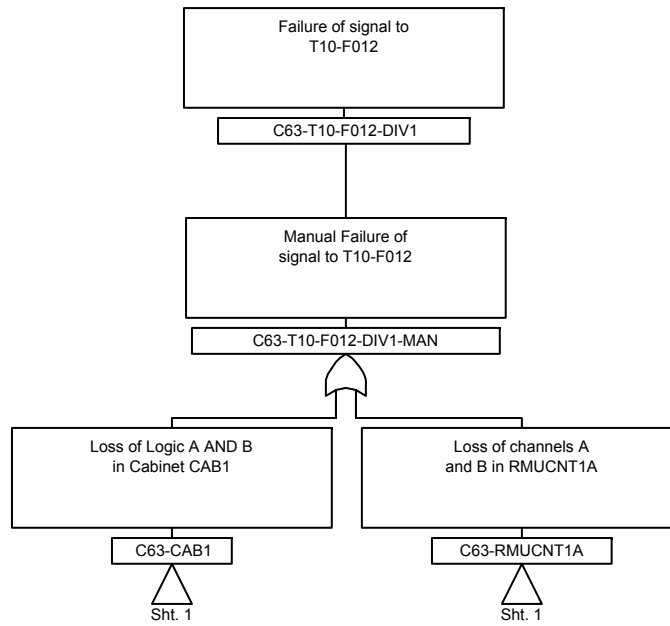

Figure 8A-8. Level 2 Fault Trees

Sheet 11 of 147

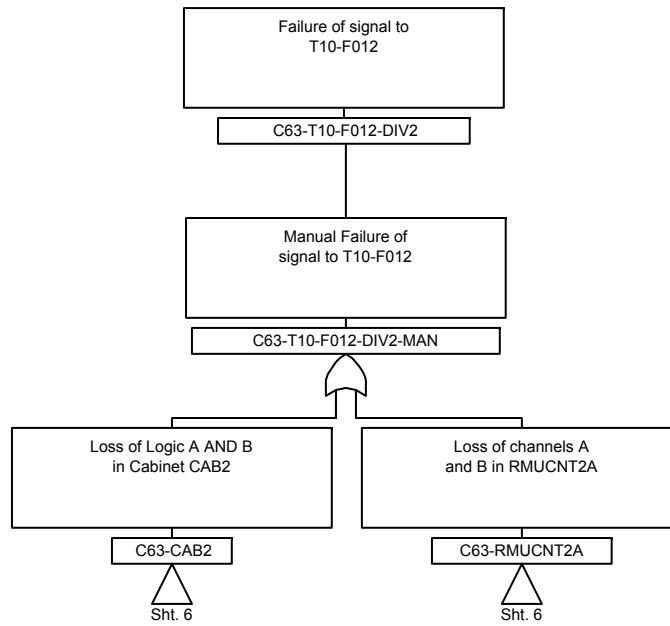

Figure 8A-8. Level 2 Fault Trees

Sheet 12 of 147

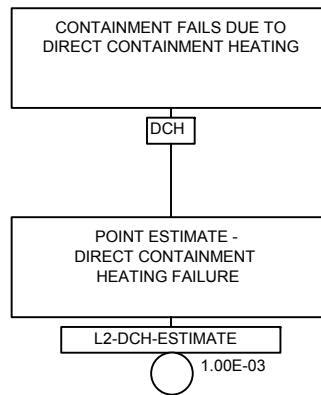

Figure 8A-8. Level 2 Fault Trees

Sheet 13 of 147

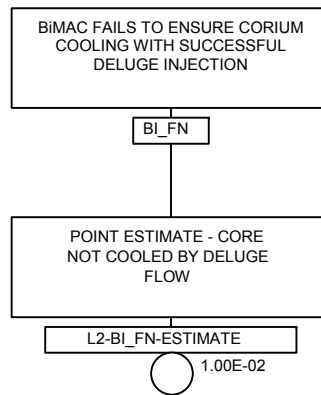

Figure 8A-8. Level 2 Fault Trees

Sheet 14 of 147

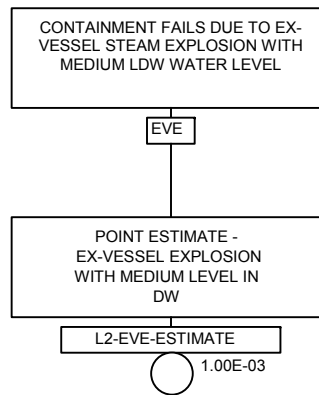

Figure 8A-8. Level 2 Fault Trees

Sheet 15 of 147

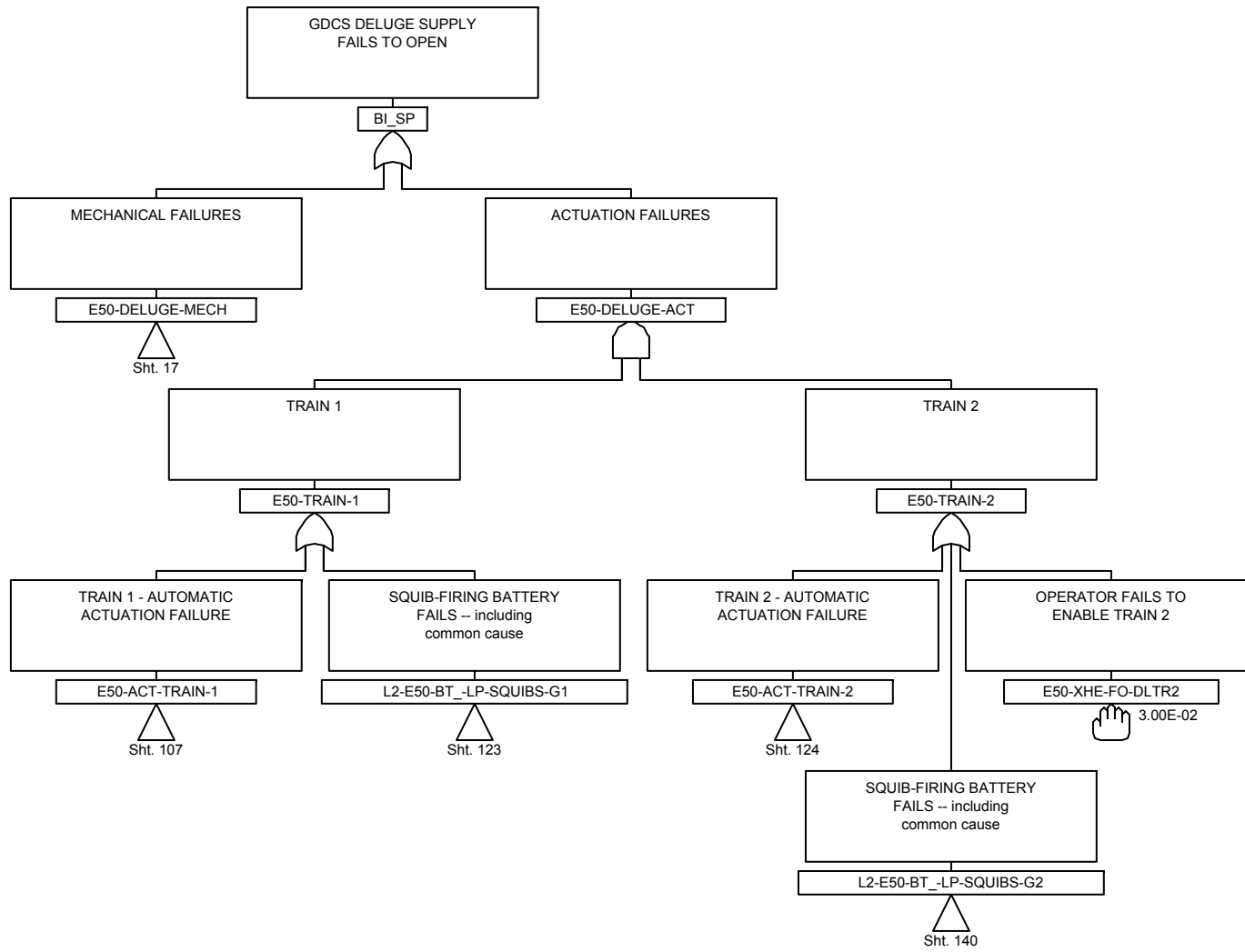

Figure 8A-8. Level 2 Fault Trees
Sheet 16 of 147

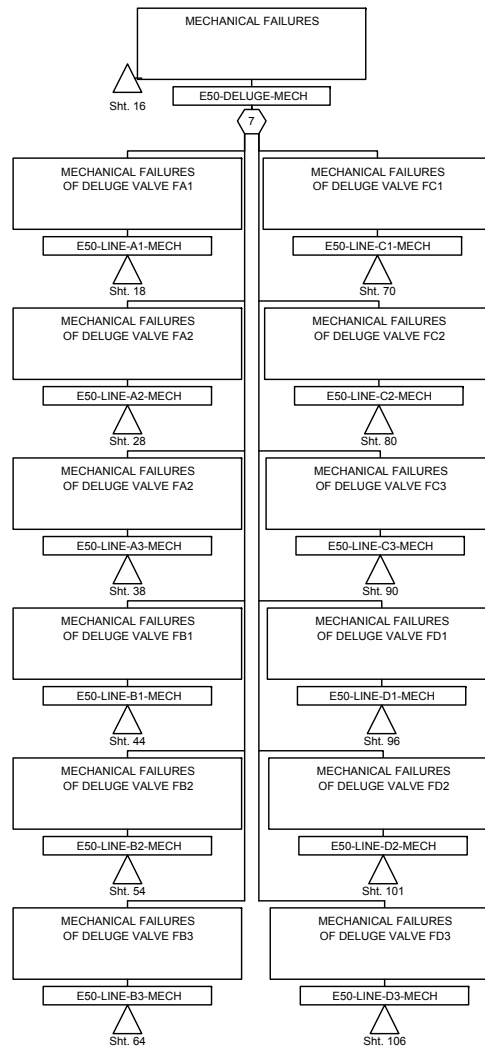

Figure 8A-8. Level 2 Fault Trees

Sheet 17 of 147

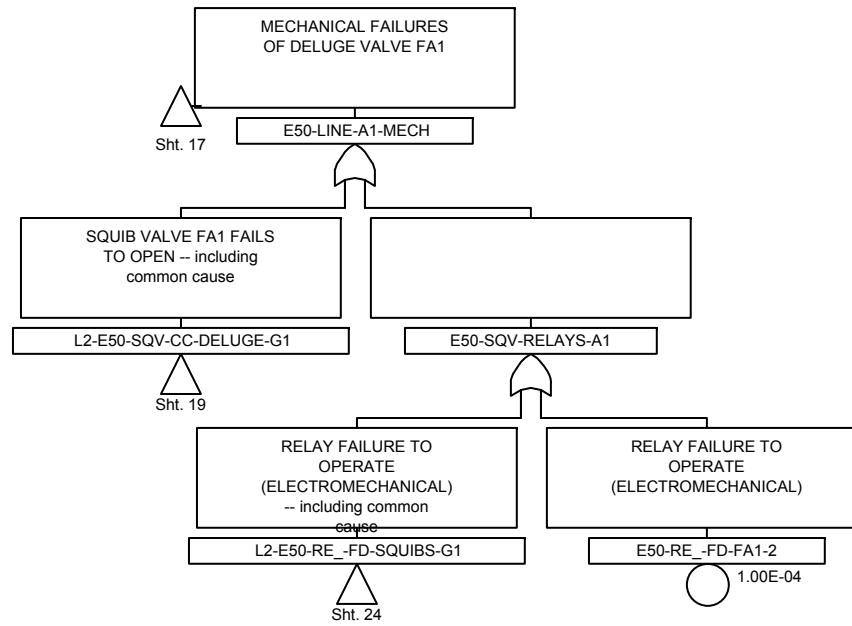

Figure 8A-8. Level 2 Fault Trees

Sheet 18 of 147

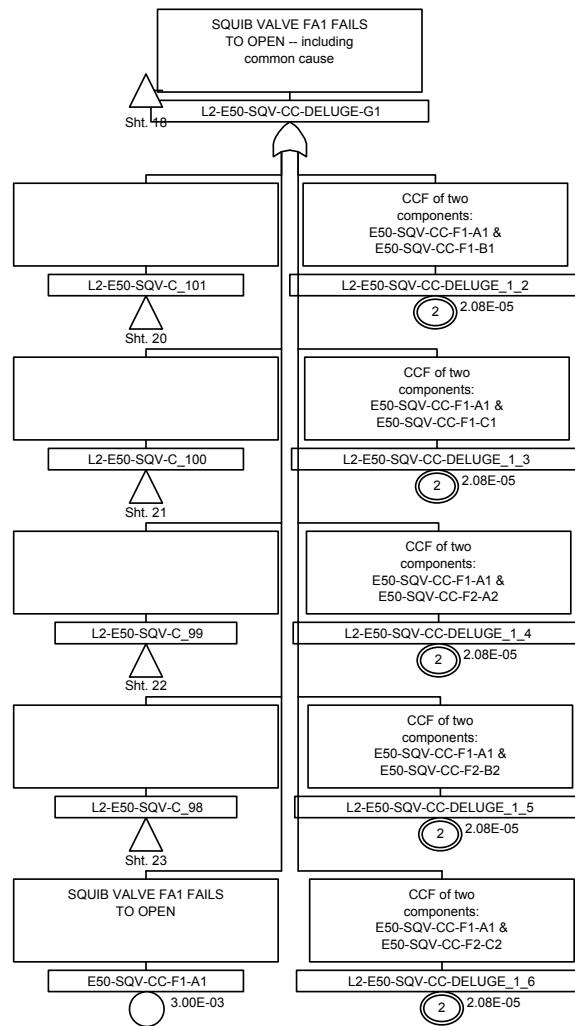

Figure 8A-8. Level 2 Fault Trees

Sheet 19 of 147

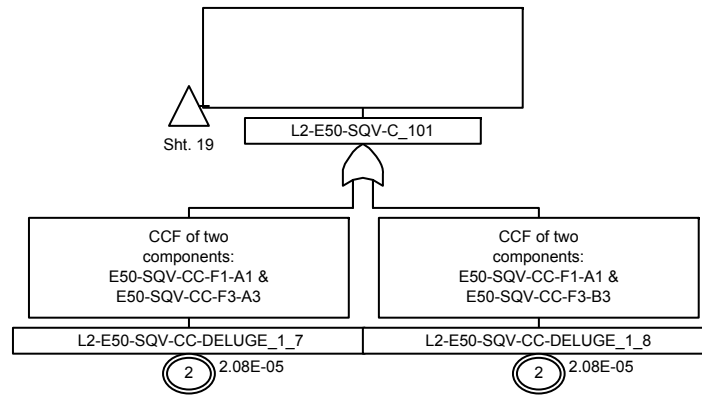

Figure 8A-8. Level 2 Fault Trees

Sheet 20 of 147

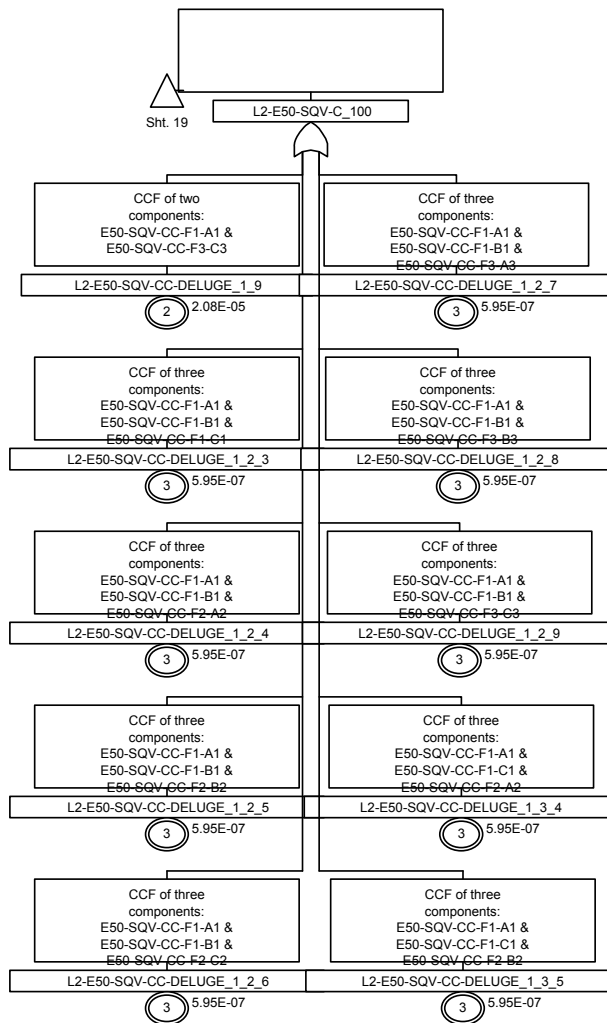

Figure 8A-8. Level 2 Fault Trees

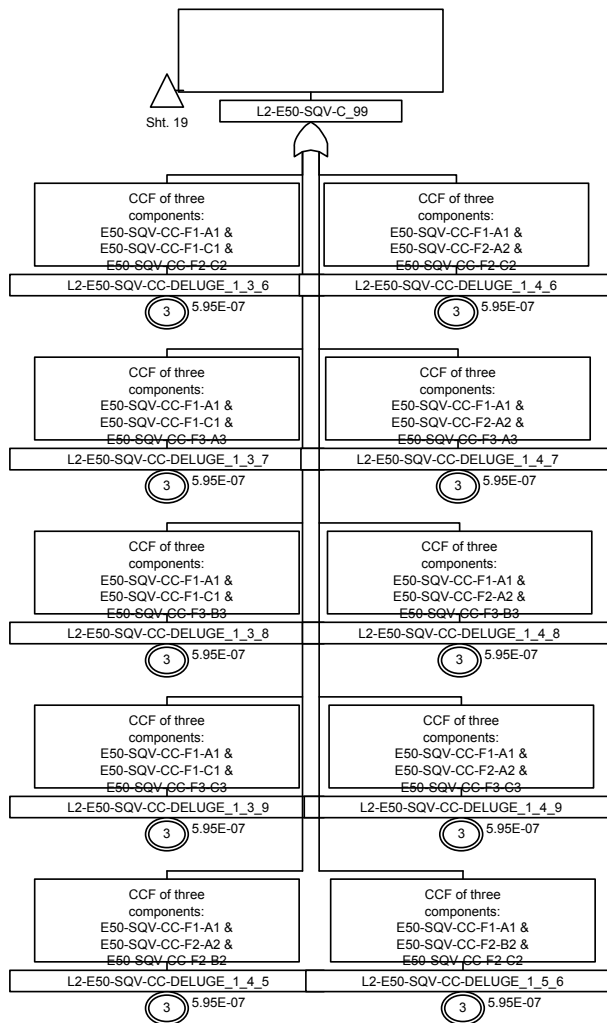

Figure 8A-8. Level 2 Fault Trees

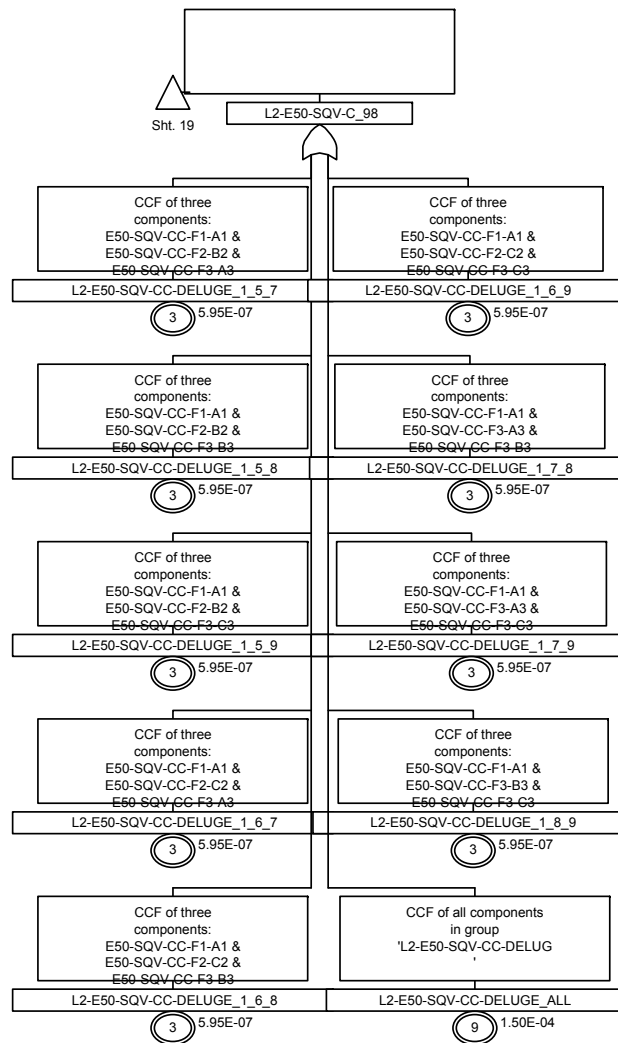

Figure 8A-8. Level 2 Fault Trees

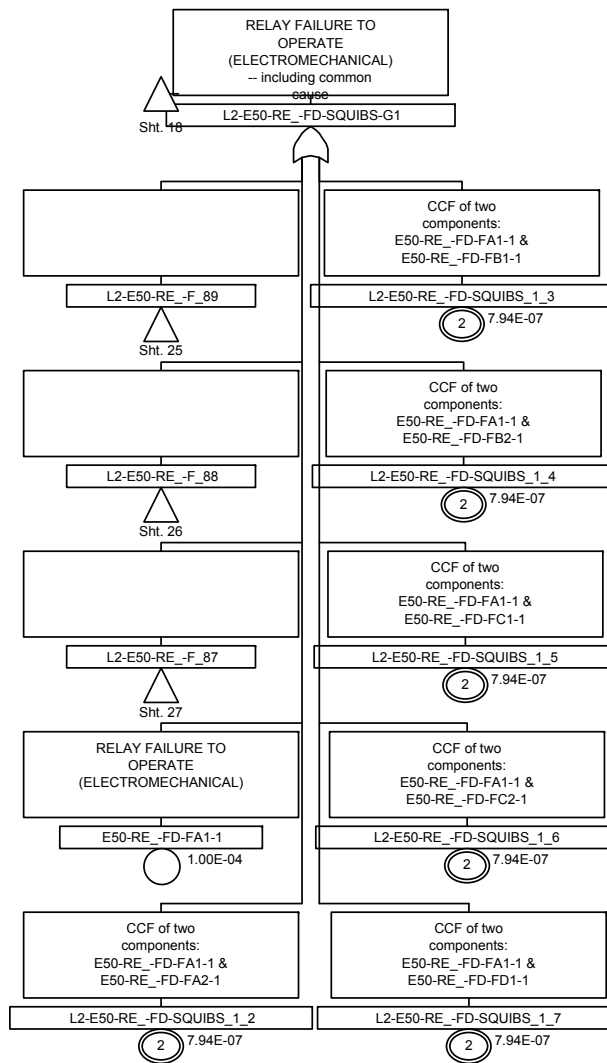

Figure 8A-8. Level 2 Fault Trees

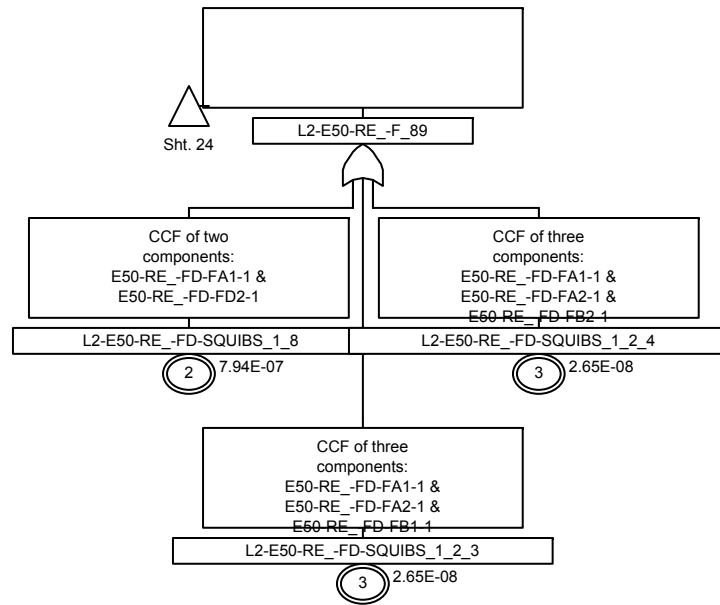

Figure 8A-8. Level 2 Fault Trees

Sheet 25 of 147

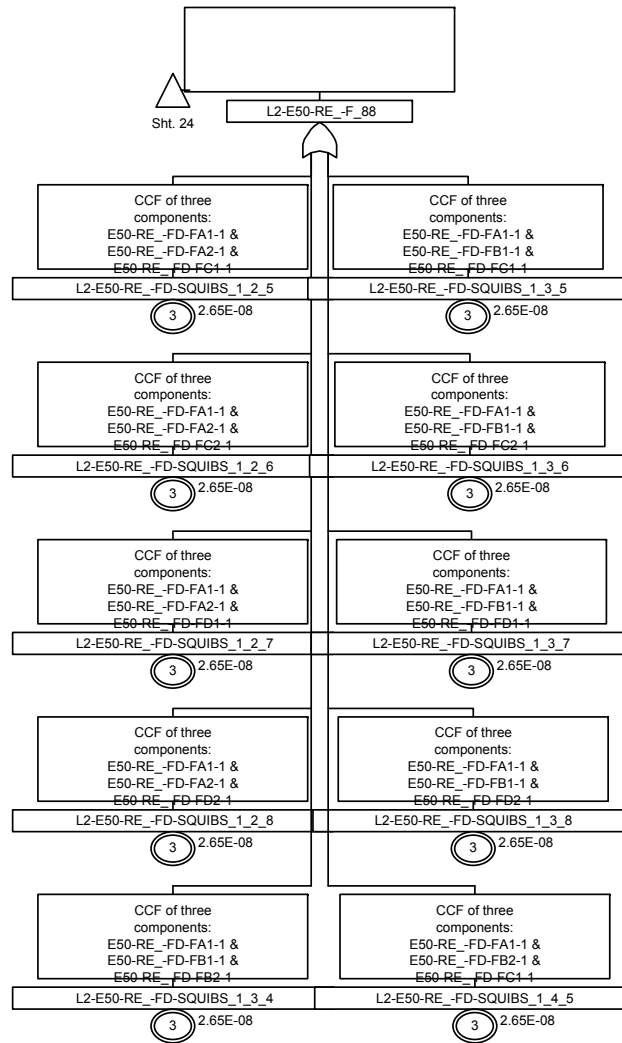

Figure 8A-8. Level 2 Fault Trees

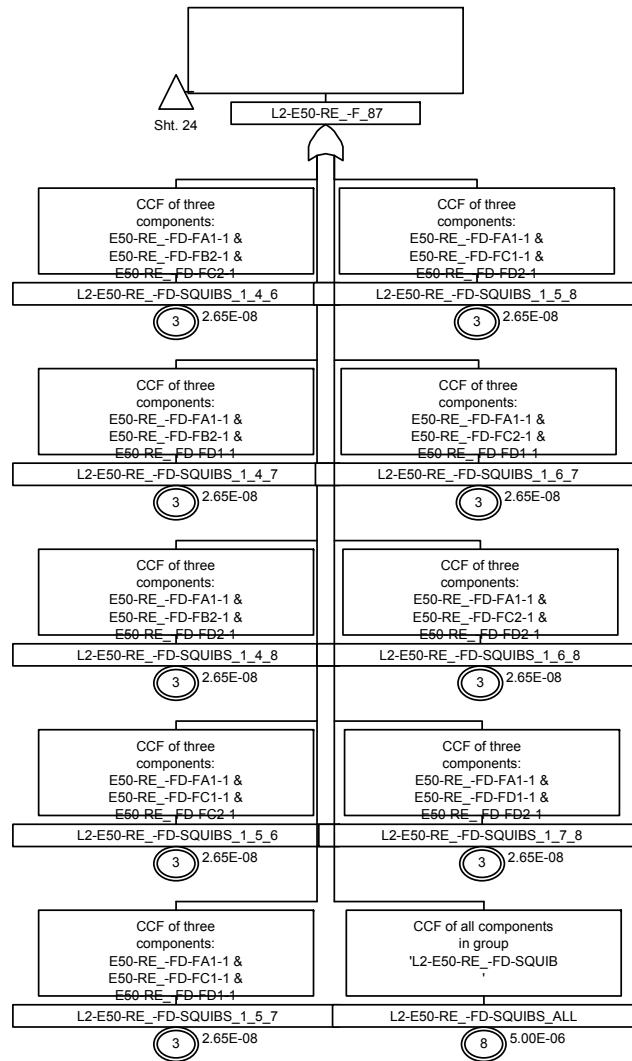

Figure 8A-8. Level 2 Fault Trees

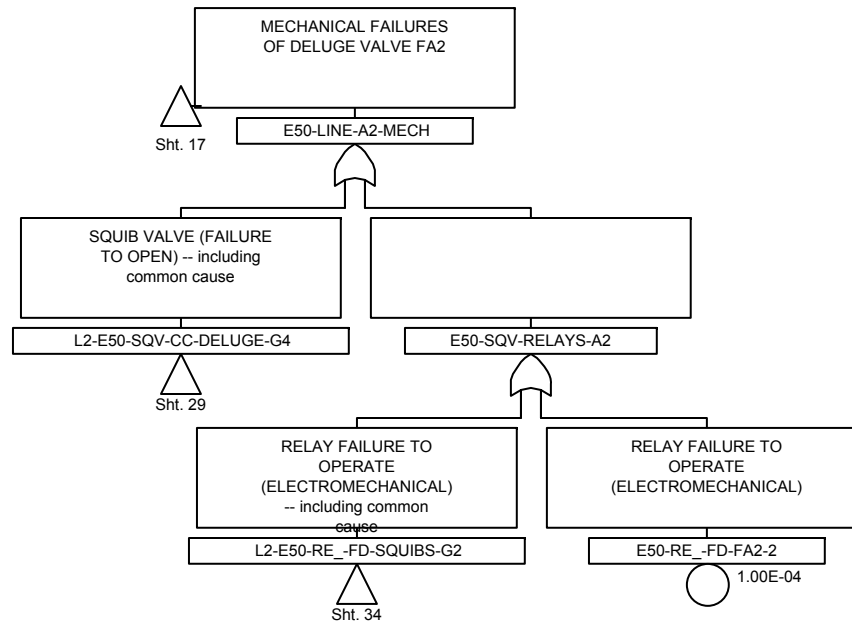

Figure 8A-8. Level 2 Fault Trees

Sheet 28 of 147

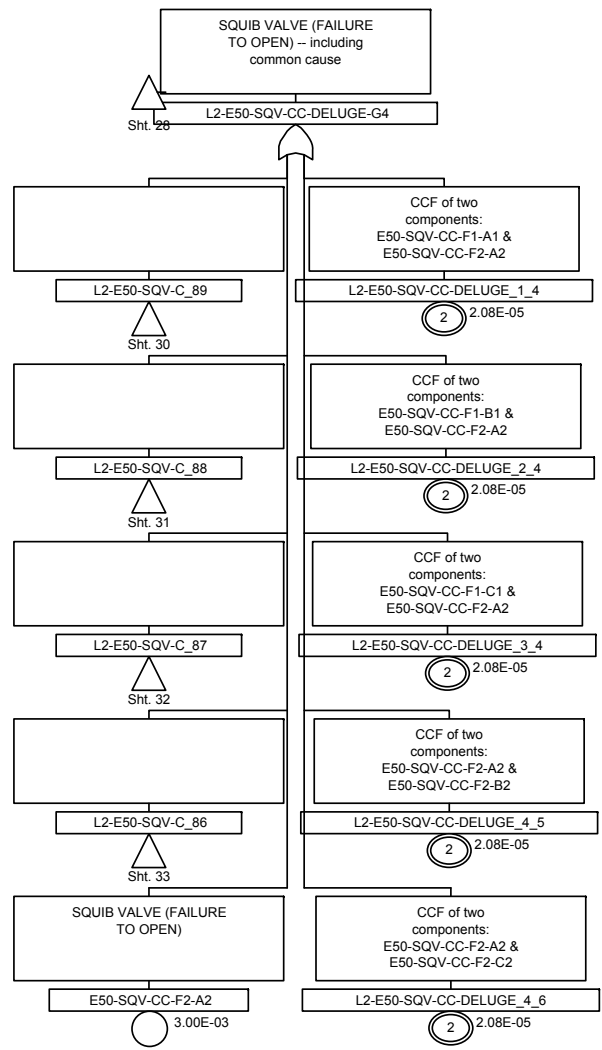

Figure 8A-8. Level 2 Fault Trees

Sheet 29 of 147

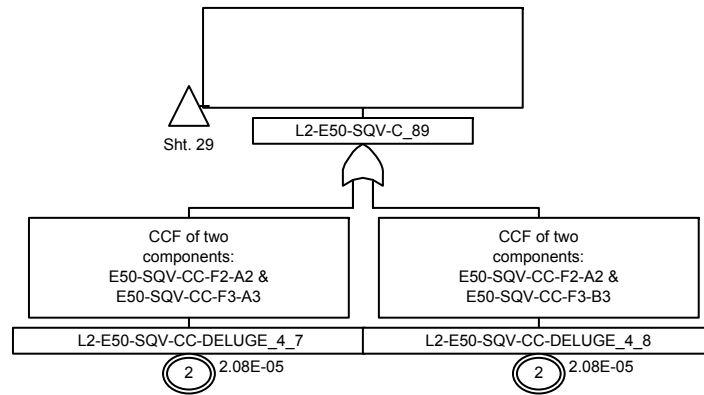

Figure 8A-8. Level 2 Fault Trees

Sheet 30 of 147

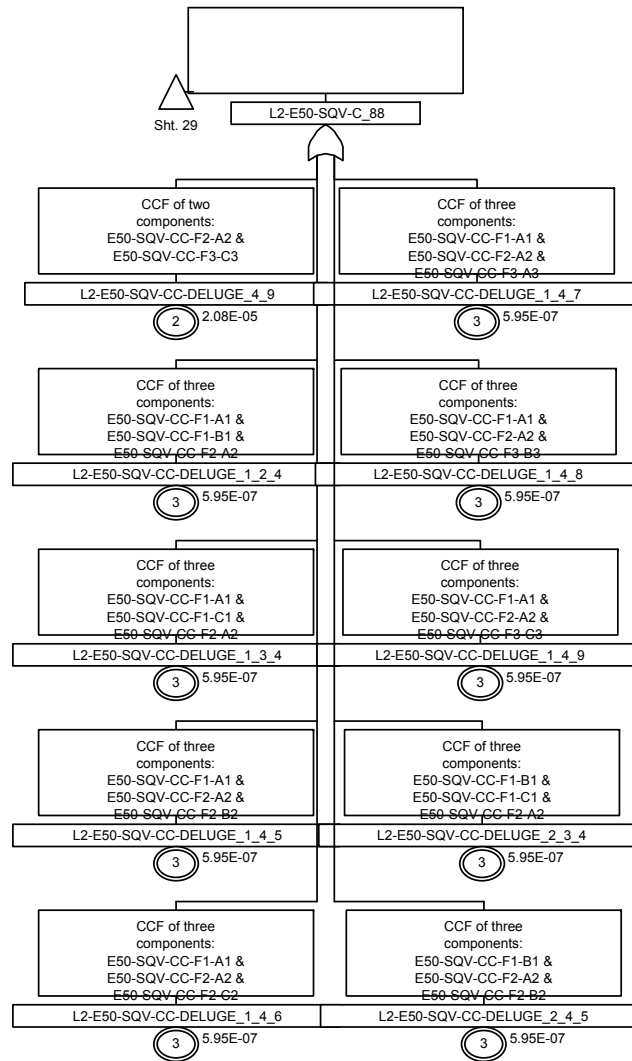

Figure 8A-8. Level 2 Fault Trees

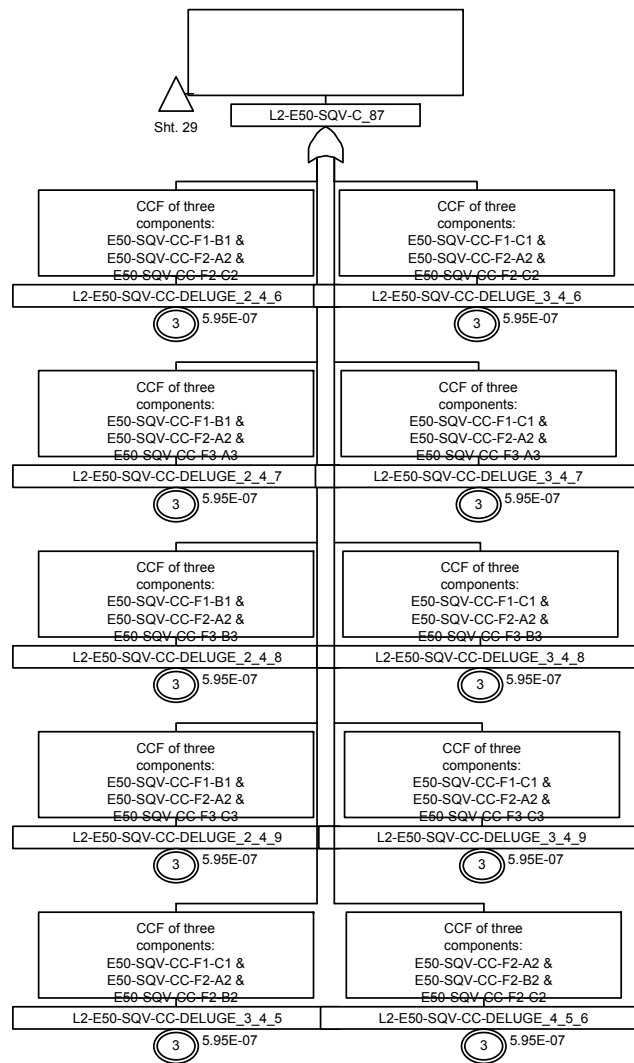

Figure 8A-8. Level 2 Fault Trees

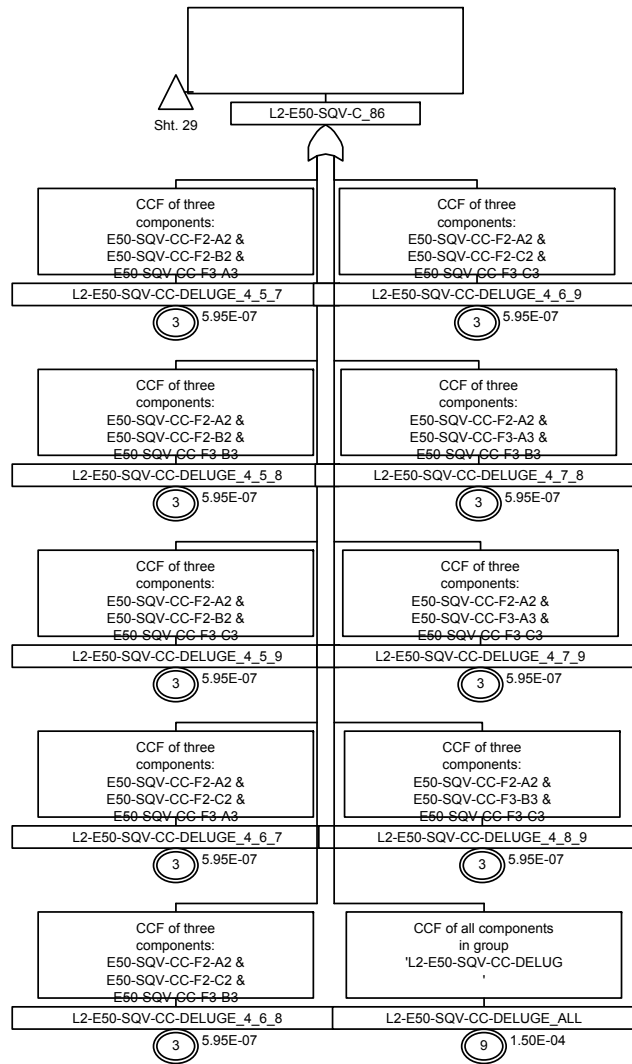

Figure 8A-8. Level 2 Fault Trees

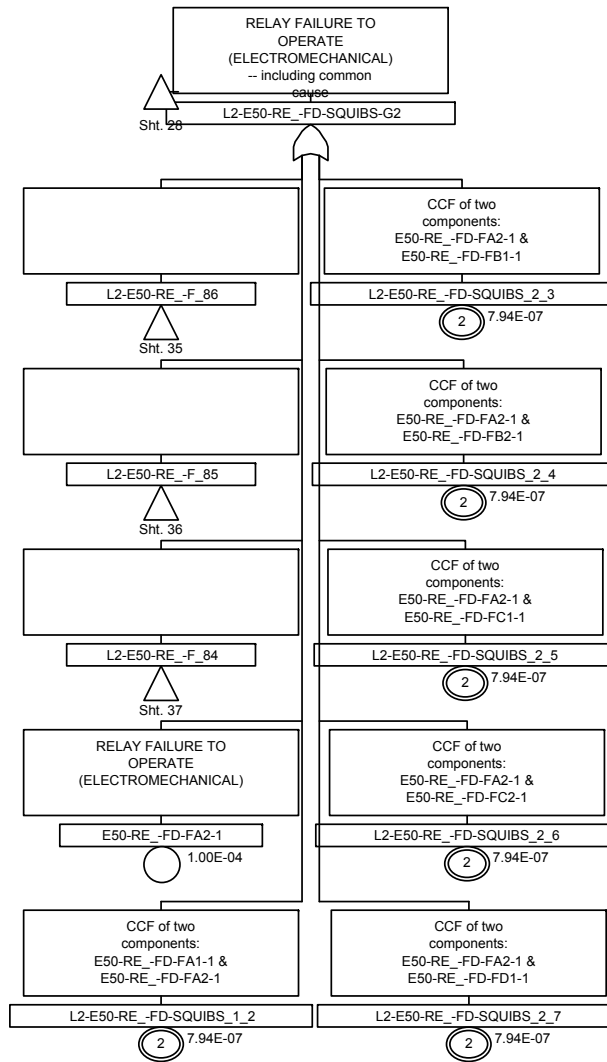

Figure 8A-8. Level 2 Fault Trees

Sheet 34 of 147

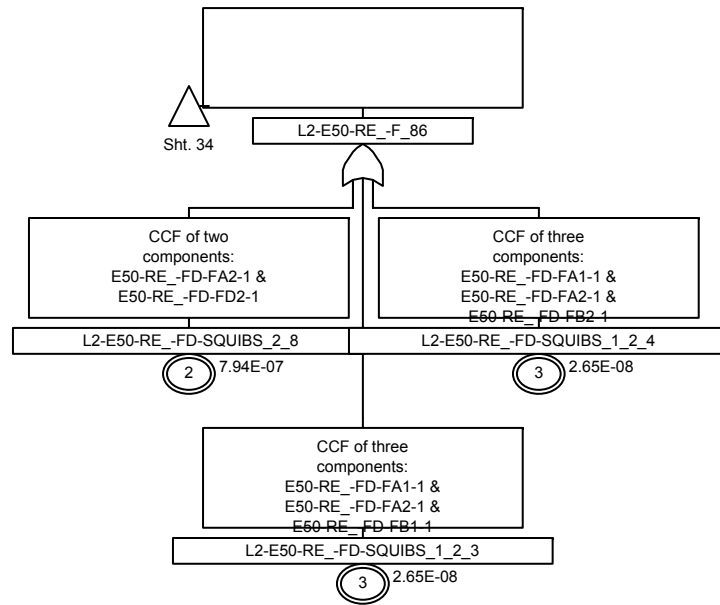

Figure 8A-8. Level 2 Fault Trees

Sheet 35 of 147

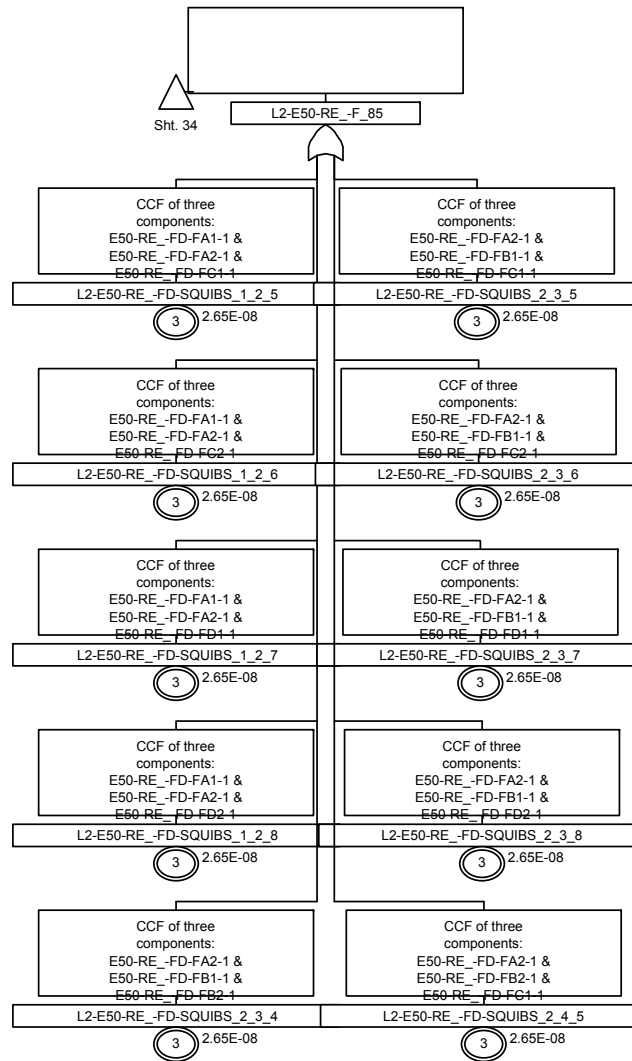

Figure 8A-8. Level 2 Fault Trees

Sheet 36 of 147

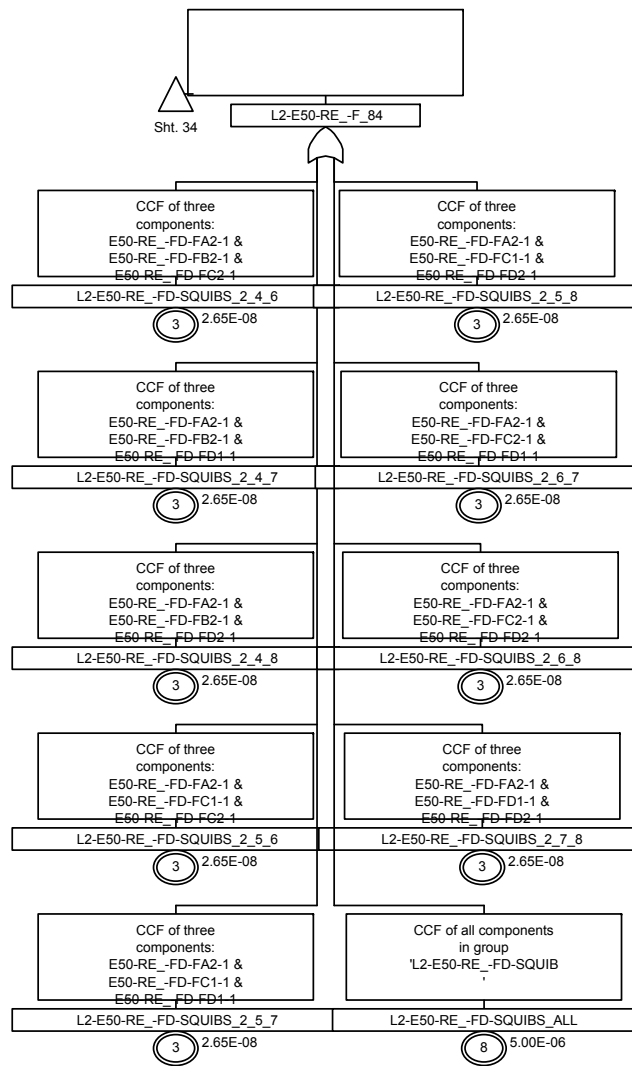

Figure 8A-8. Level 2 Fault Trees

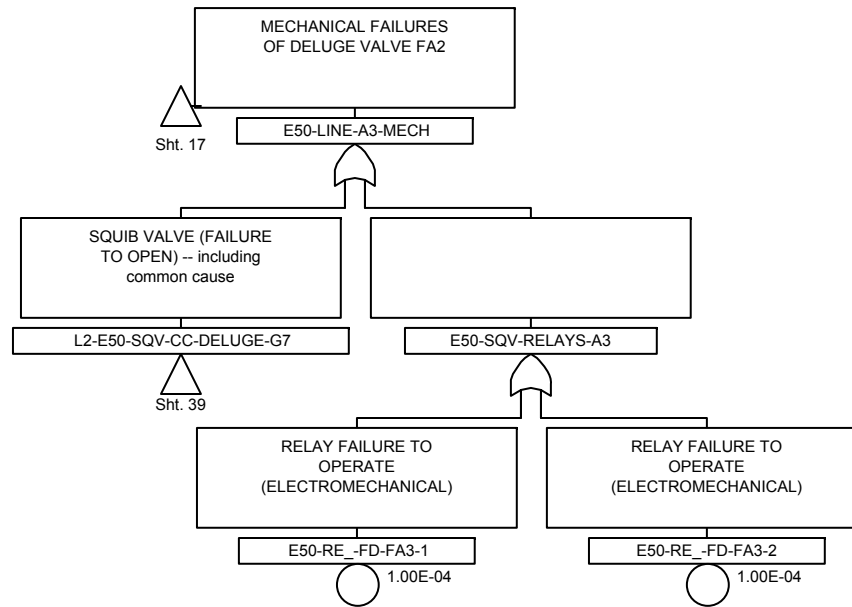

Figure 8A-8. Level 2 Fault Trees

Sheet 38 of 147

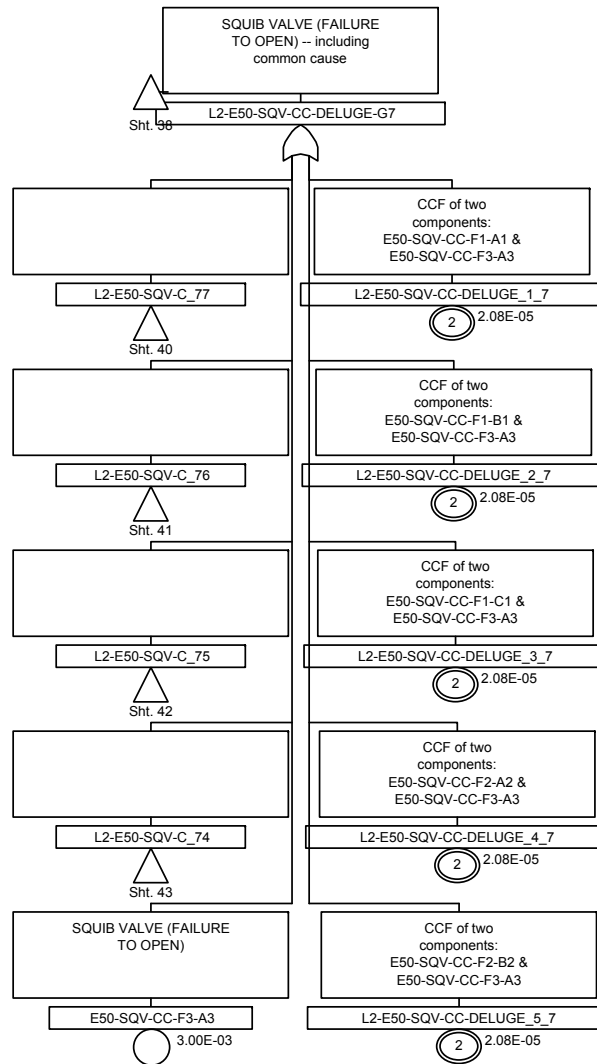

Figure 8A-8. Level 2 Fault Trees

Sheet 39 of 147

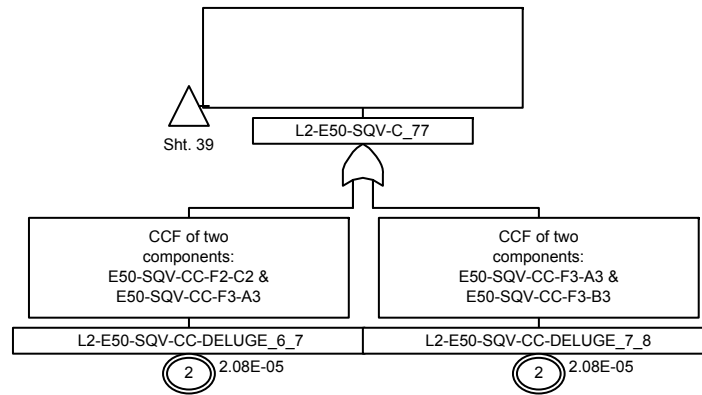

Figure 8A-8. Level 2 Fault Trees

Sheet 40 of 147

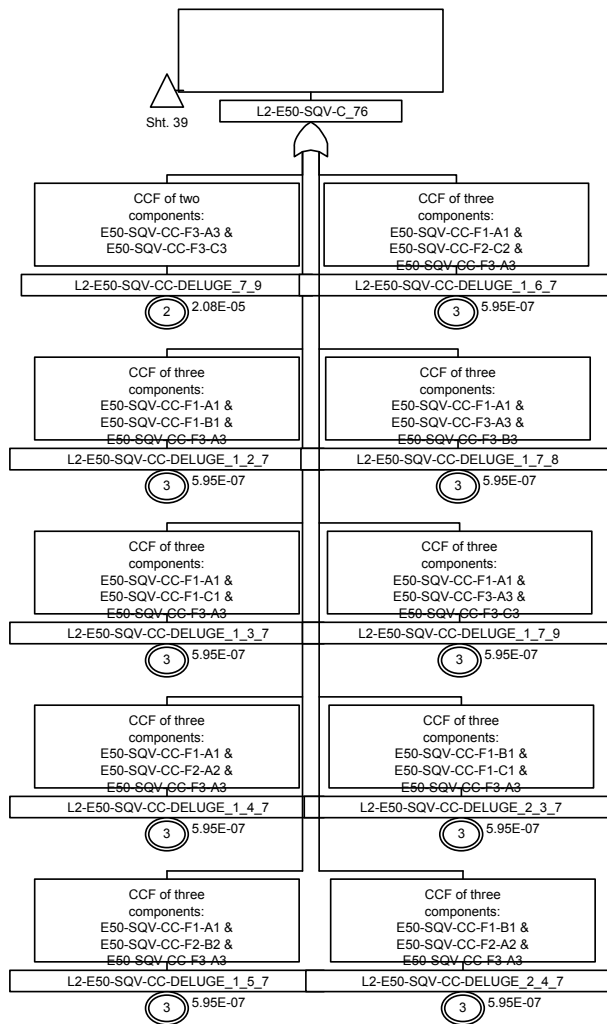

Figure 8A-8. Level 2 Fault Trees

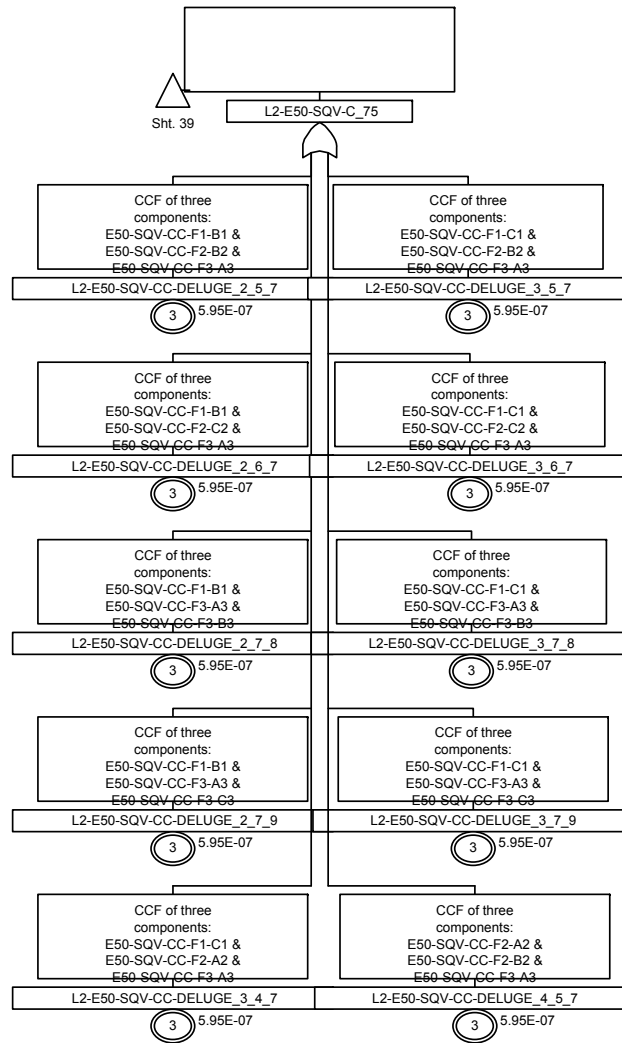

Figure 8A-8. Level 2 Fault Trees



Figure 8A-8. Level 2 Fault Trees

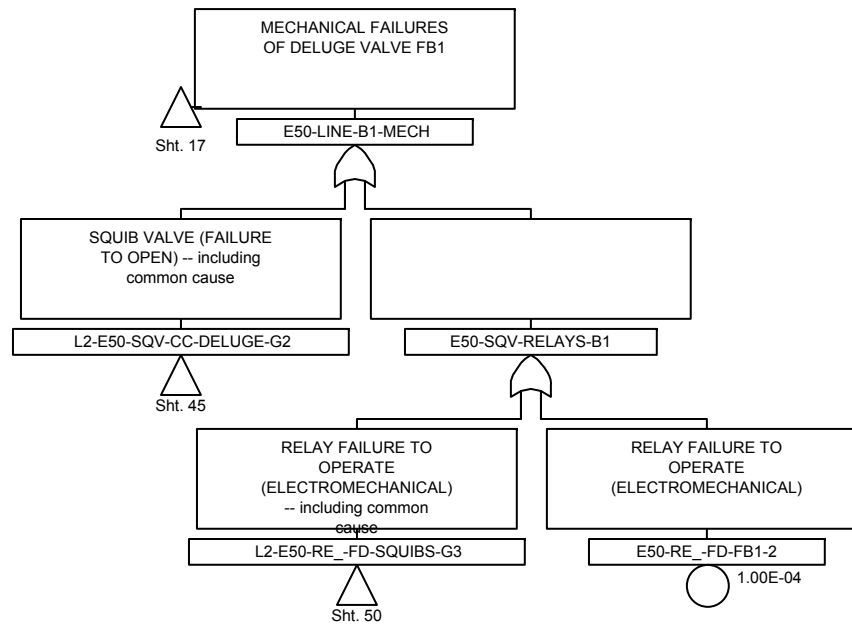

Figure 8A-8. Level 2 Fault Trees

Sheet 44 of 147

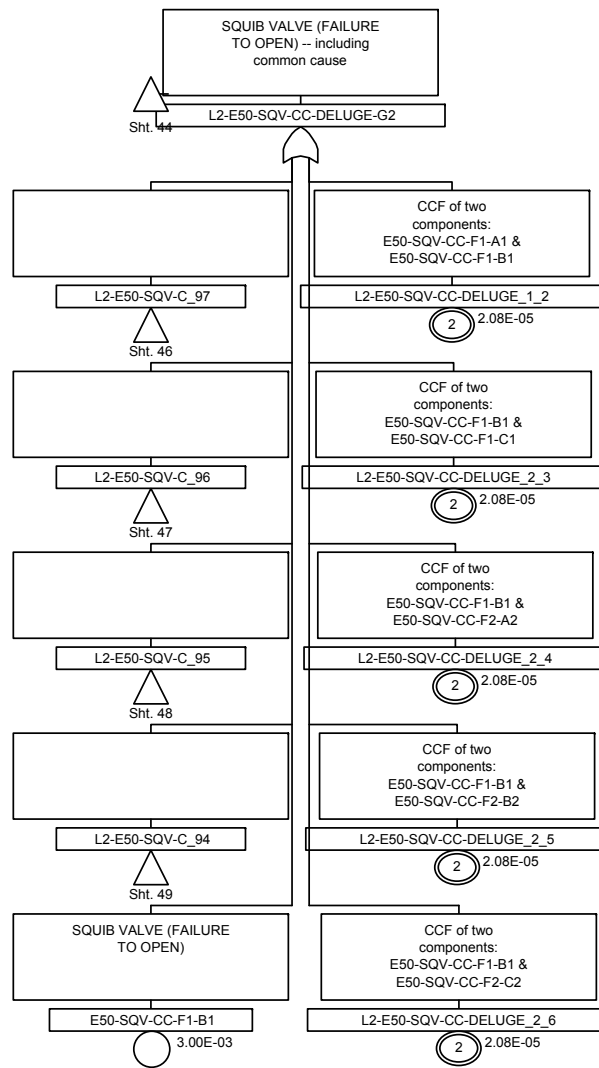

Figure 8A-8. Level 2 Fault Trees

Sheet 45 of 147

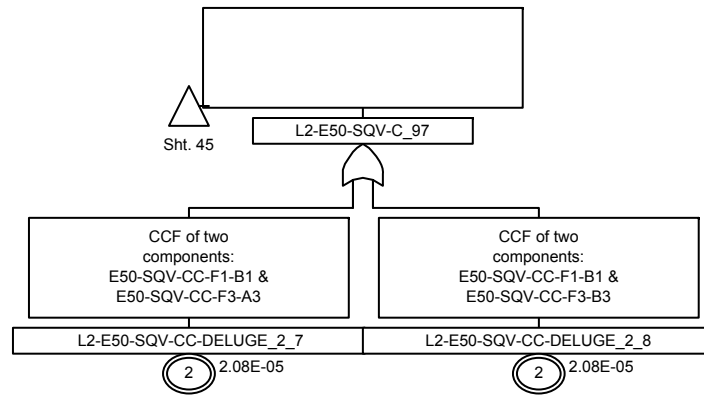

Figure 8A-8. Level 2 Fault Trees

Sheet 46 of 147

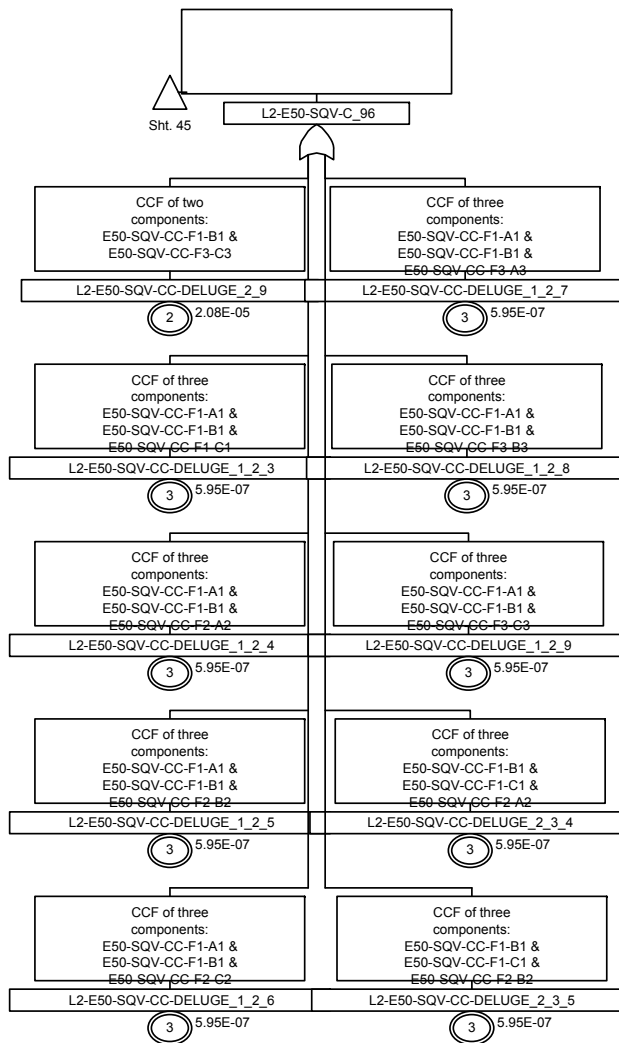

Figure 8A-8. Level 2 Fault Trees

Sheet 47 of 147

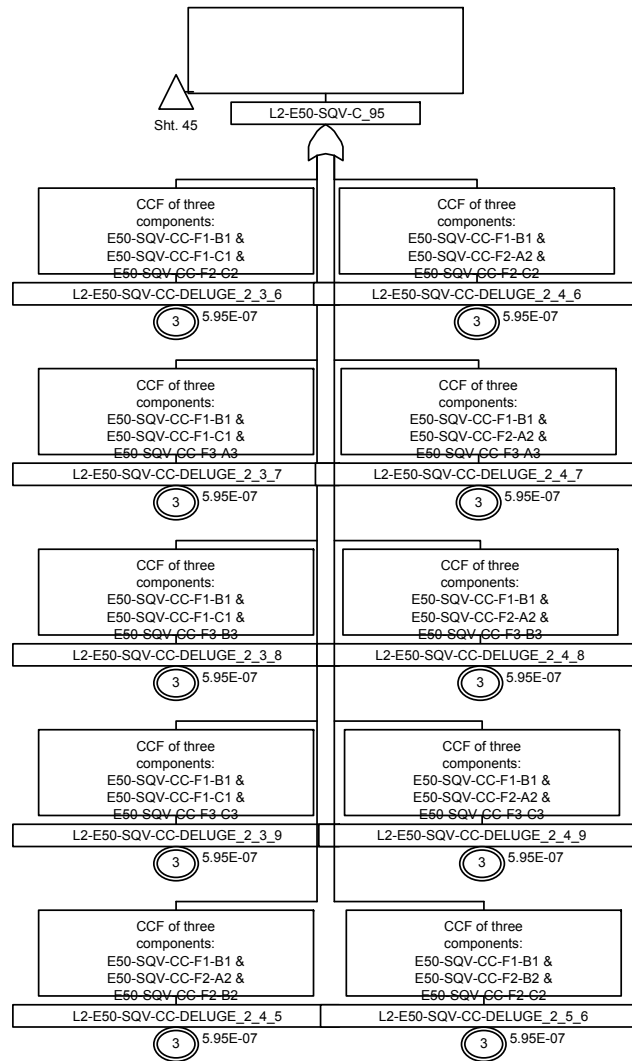

Figure 8A-8. Level 2 Fault Trees

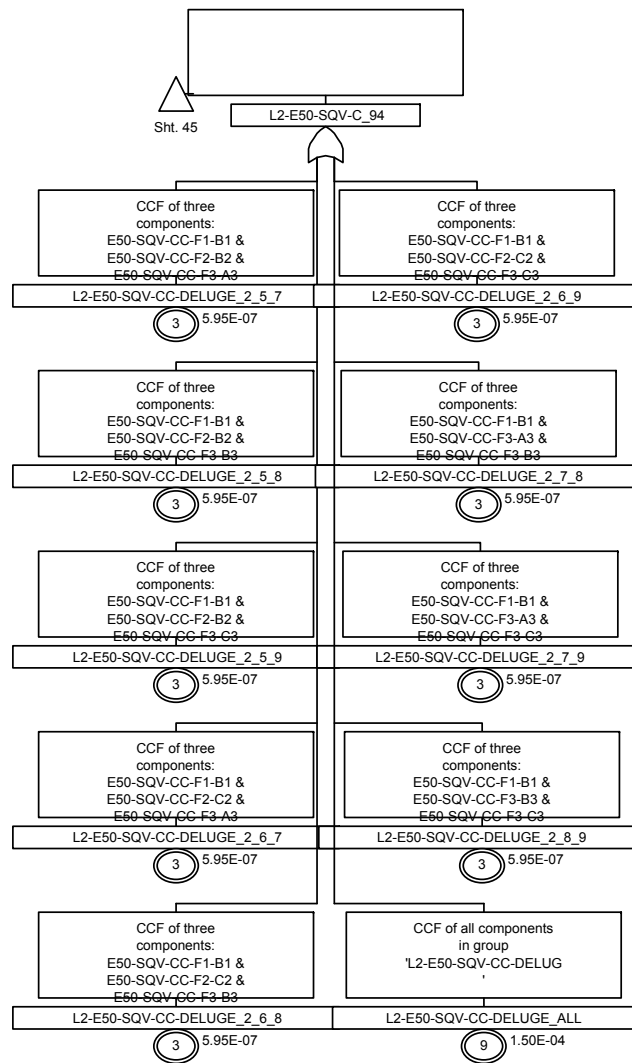

Figure 8A-8. Level 2 Fault Trees

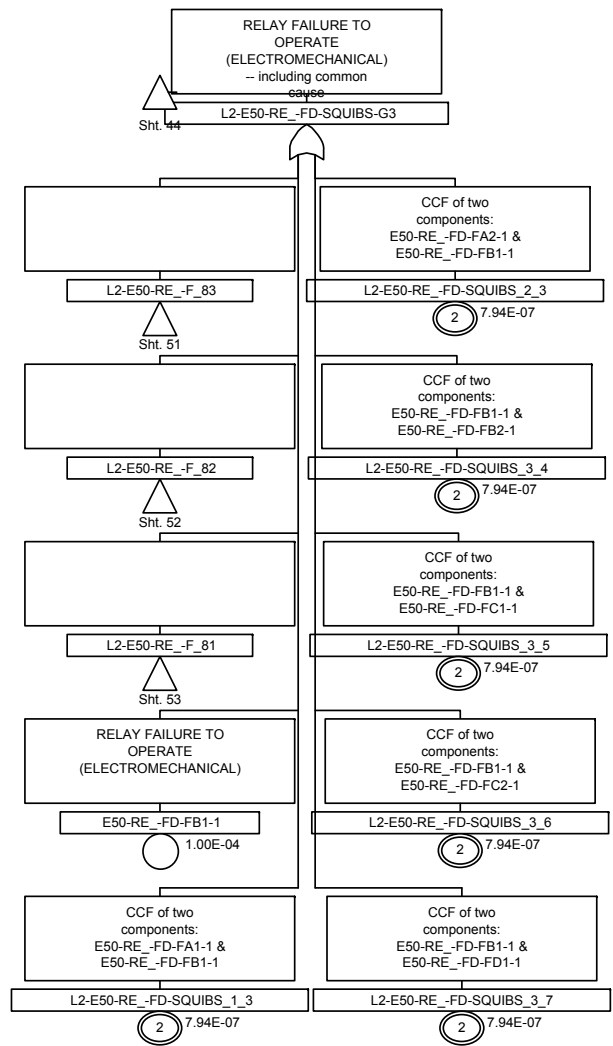

Figure 8A-8. Level 2 Fault Trees

Sheet 50 of 147

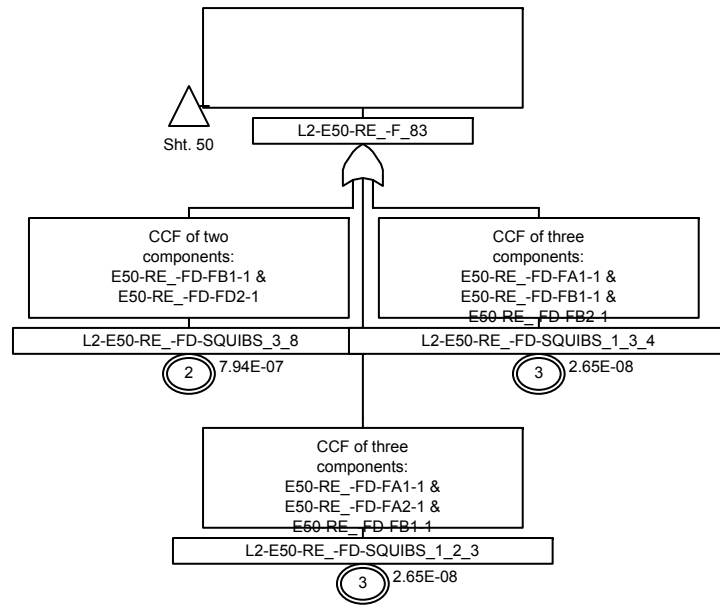

Figure 8A-8. Level 2 Fault Trees

Sheet 51 of 147

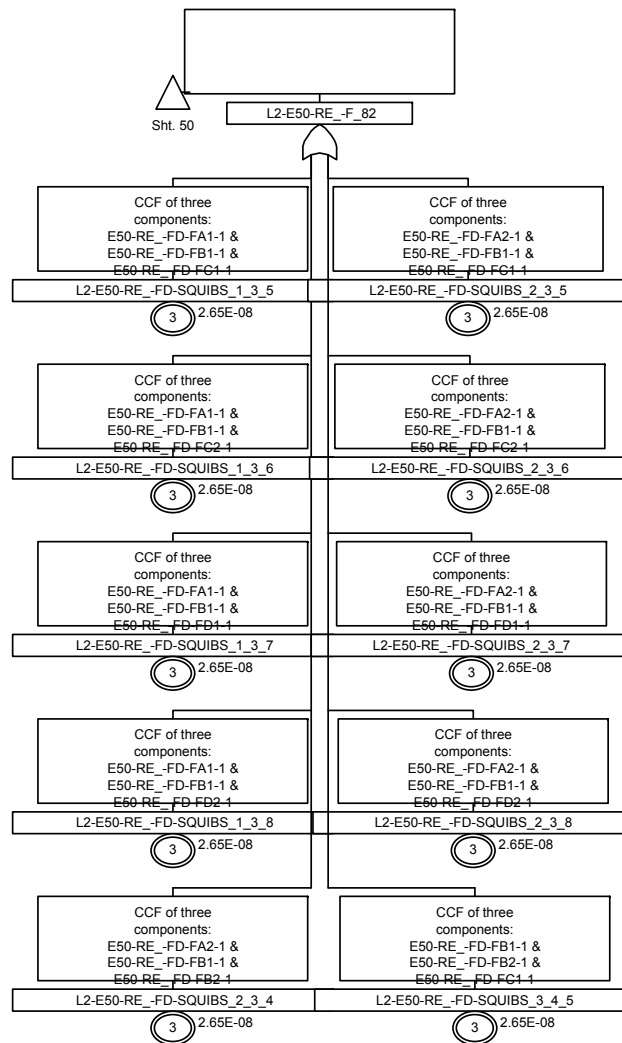

Figure 8A-8. Level 2 Fault Trees

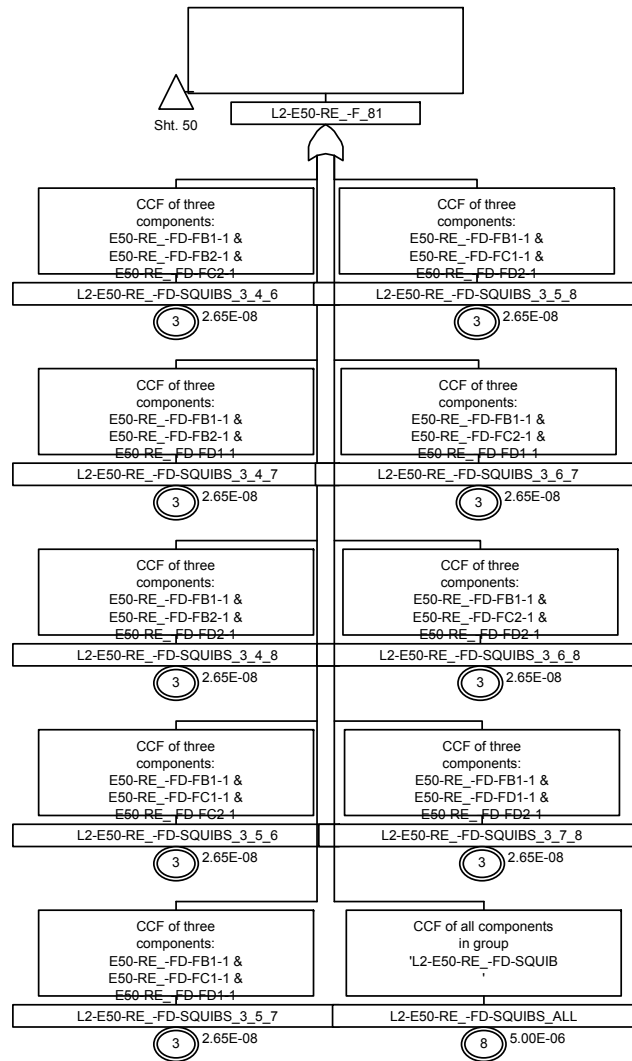

Figure 8A-8. Level 2 Fault Trees

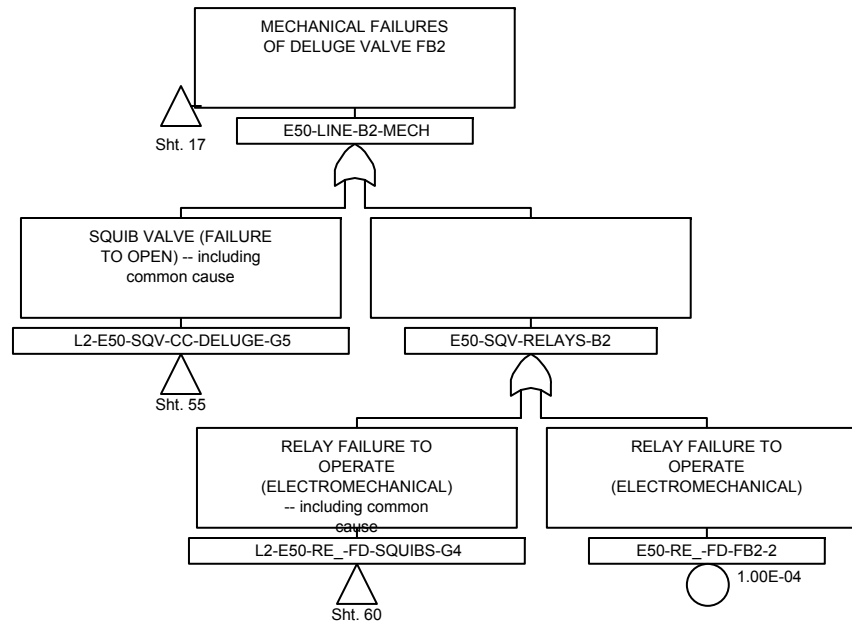

Figure 8A-8. Level 2 Fault Trees

Sheet 54 of 147

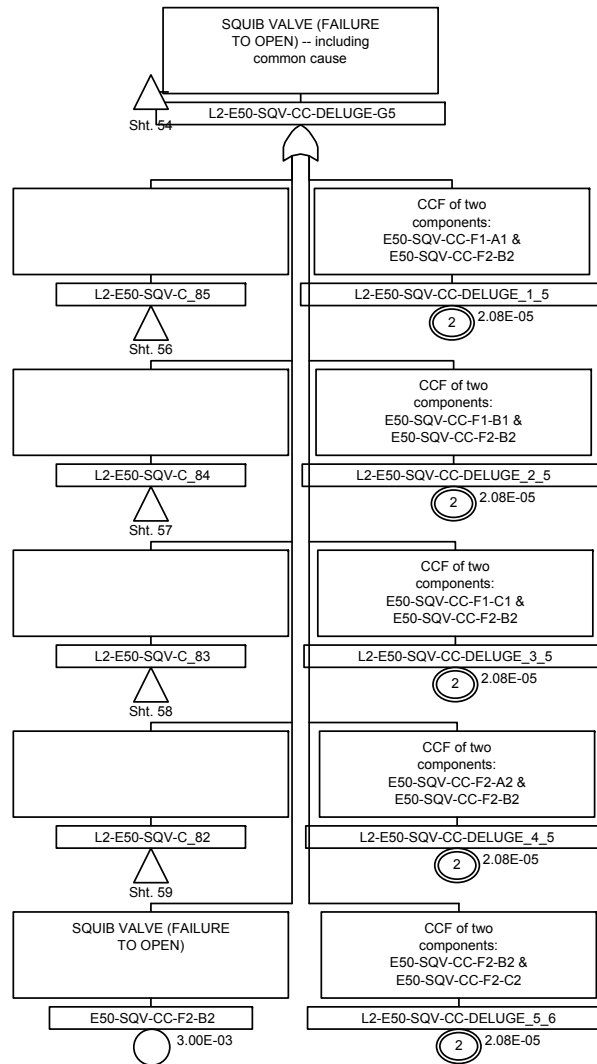

Figure 8A-8. Level 2 Fault Trees

Sheet 55 of 147

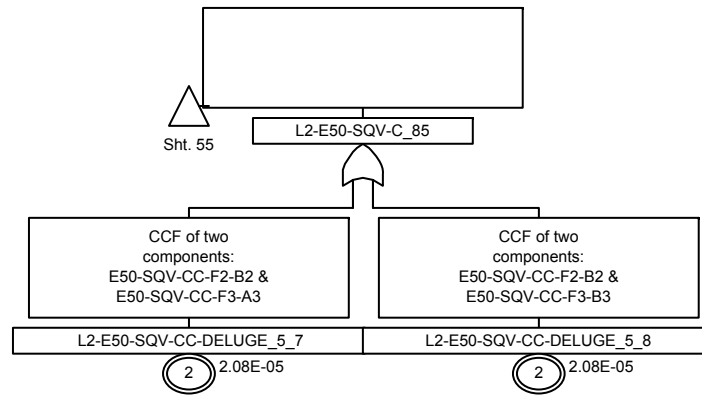

Figure 8A-8. Level 2 Fault Trees

Sheet 56 of 147

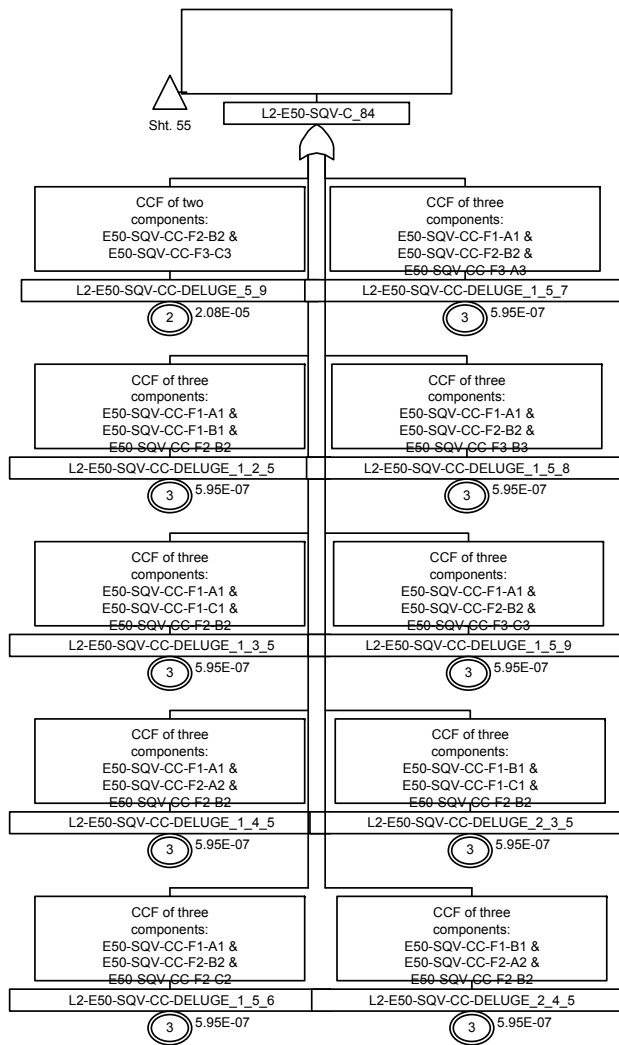

Figure 8A-8. Level 2 Fault Trees

Sheet 57 of 147

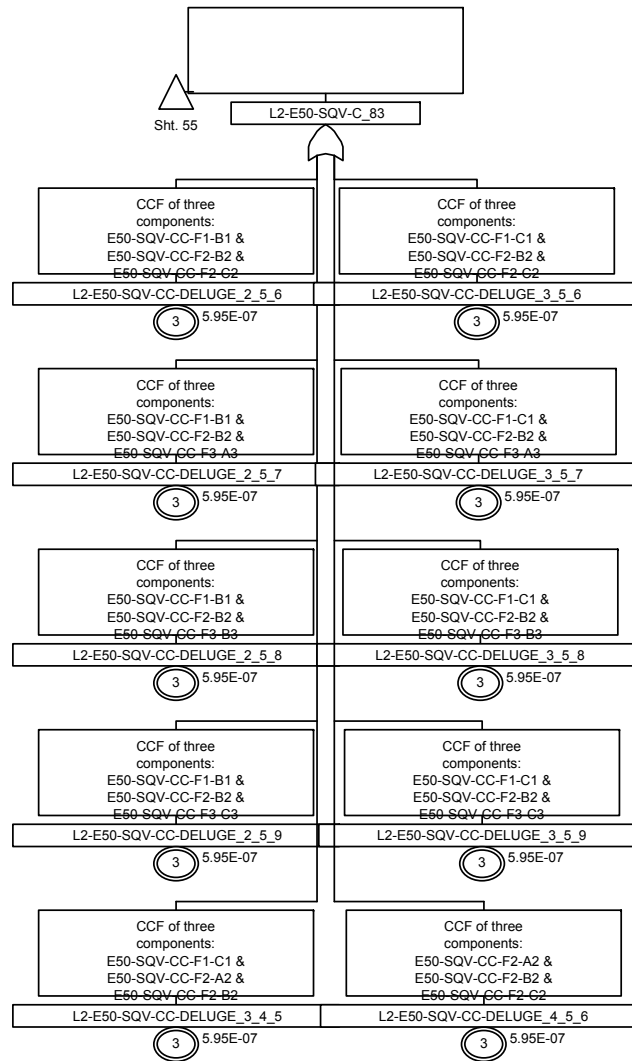

Figure 8A-8. Level 2 Fault Trees

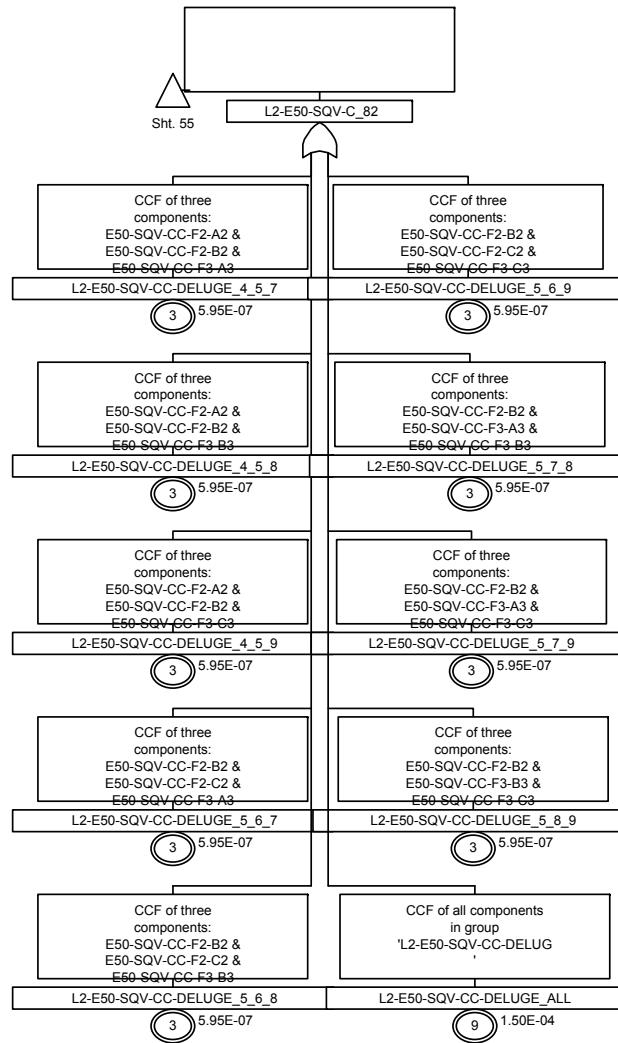

Figure 8A-8. Level 2 Fault Trees

Sheet 59 of 147

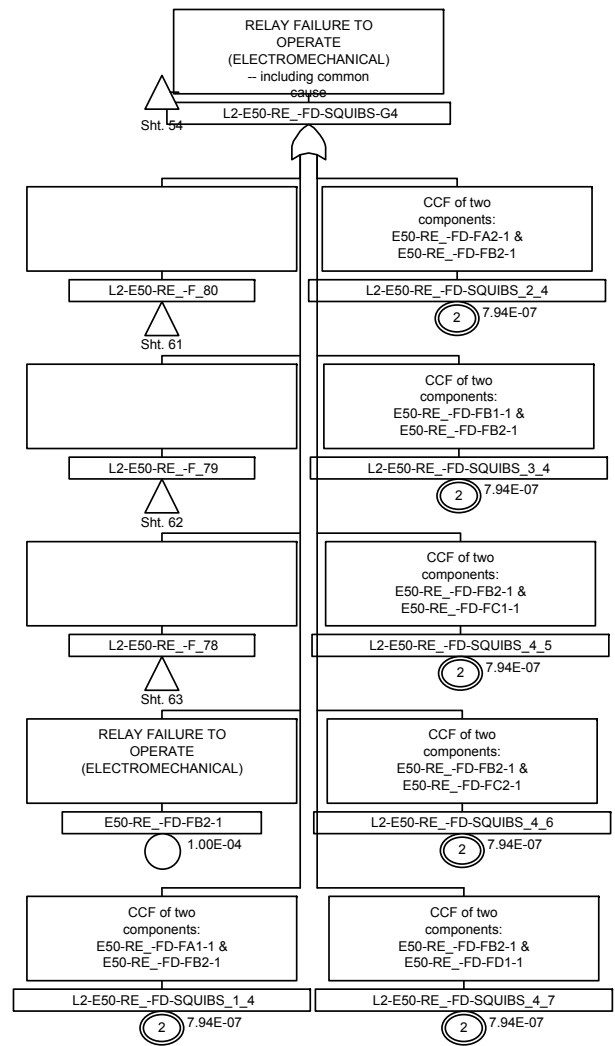

Figure 8A-8. Level 2 Fault Trees

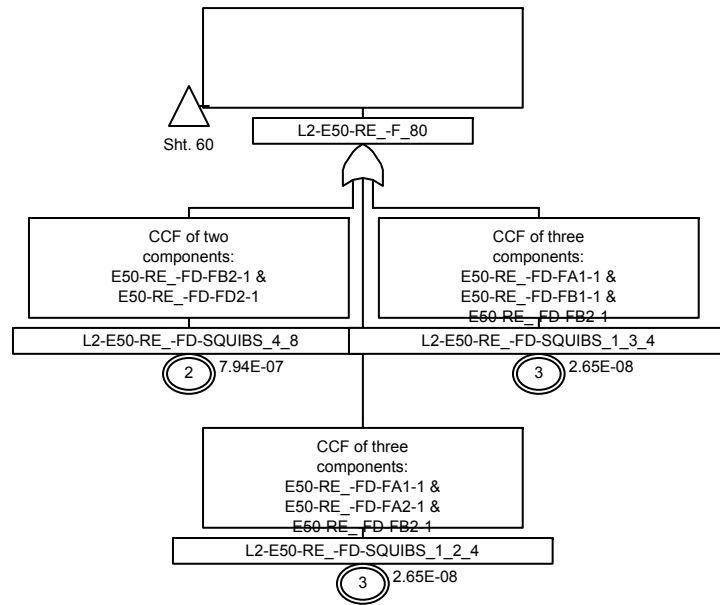

Figure 8A-8. Level 2 Fault Trees

Sheet 61 of 147

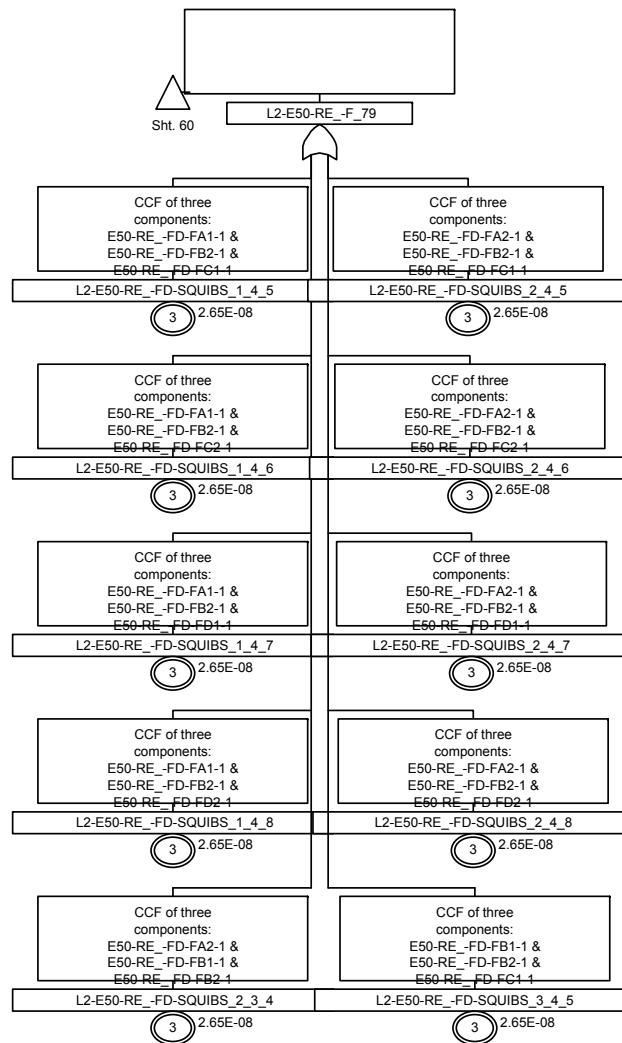

Figure 8A-8. Level 2 Fault Trees

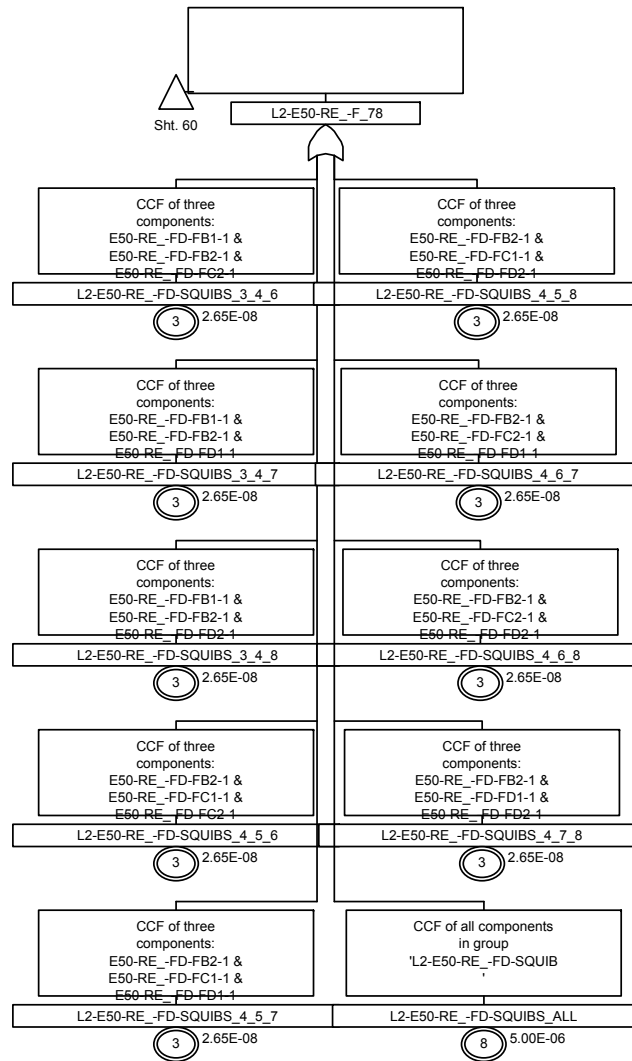

Figure 8A-8. Level 2 Fault Trees

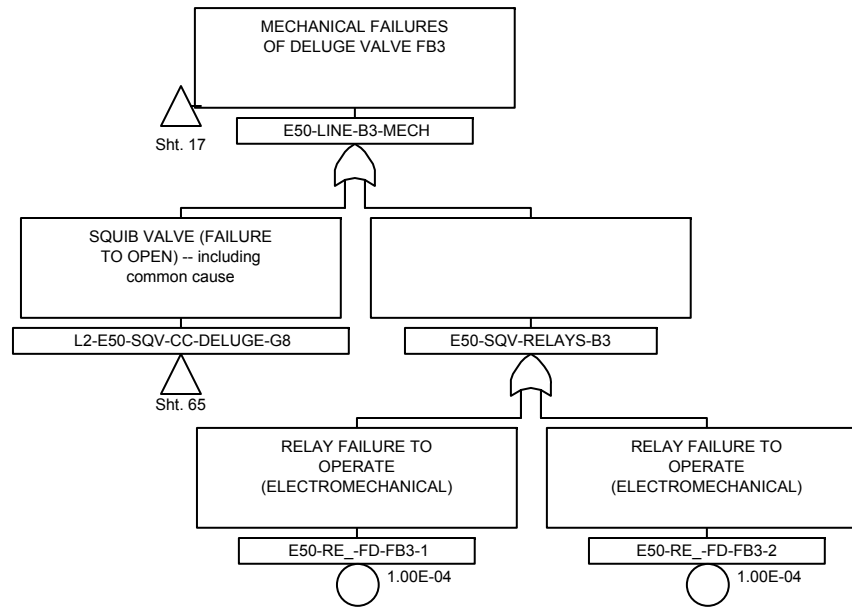

Figure 8A-8. Level 2 Fault Trees

Sheet 64 of 147

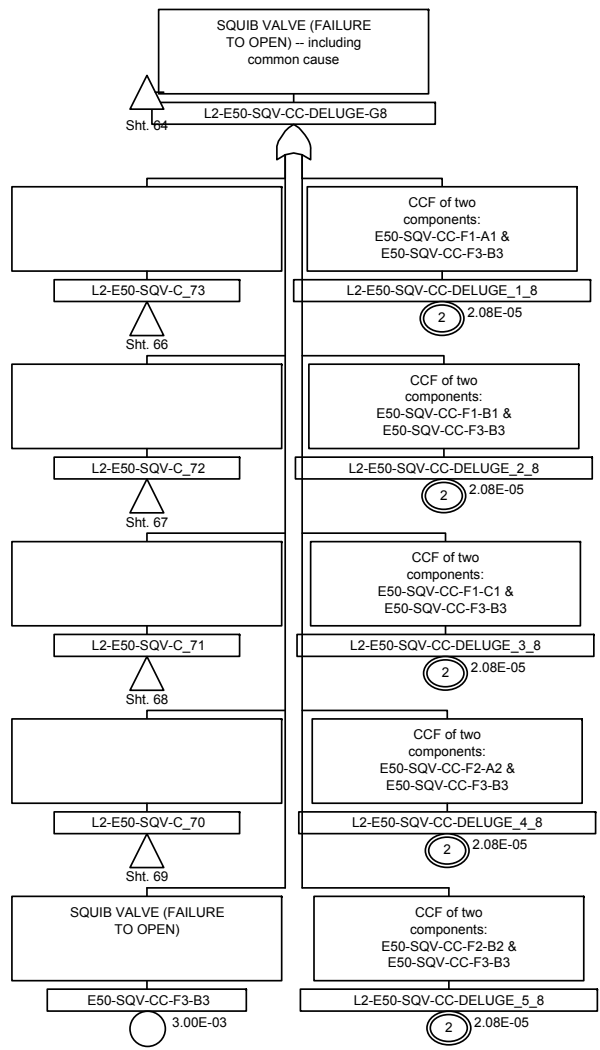

Figure 8A-8. Level 2 Fault Trees

Sheet 65 of 147

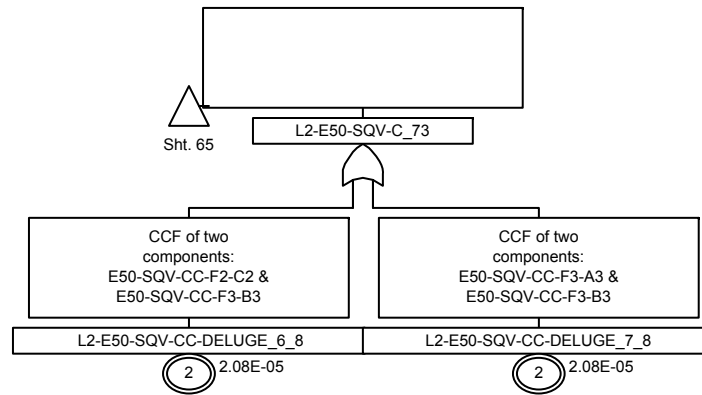

Figure 8A-8. Level 2 Fault Trees

Sheet 66 of 147

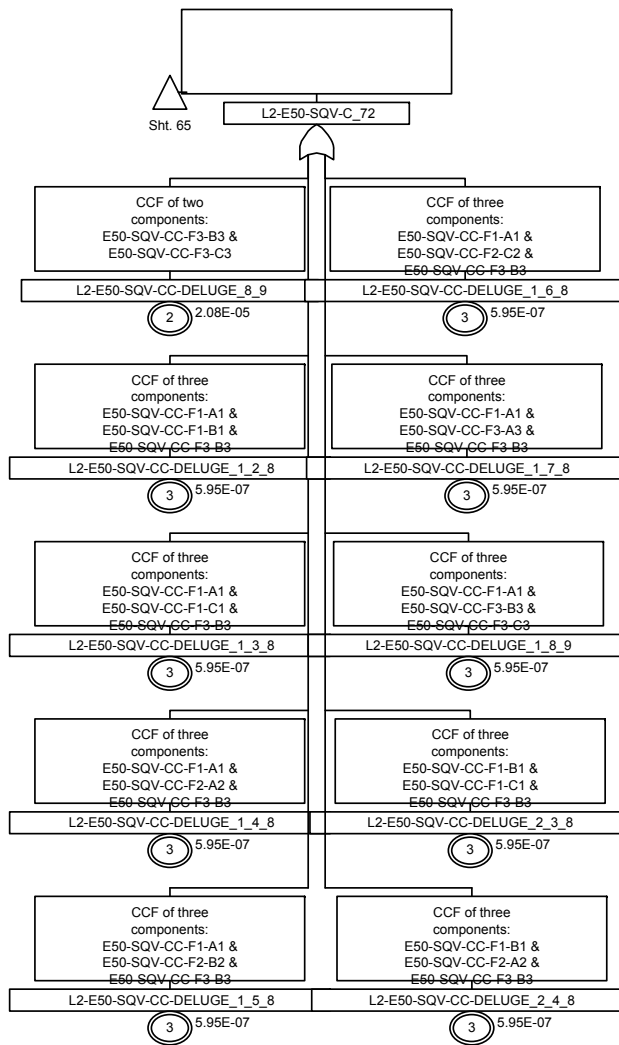

Figure 8A-8. Level 2 Fault Trees

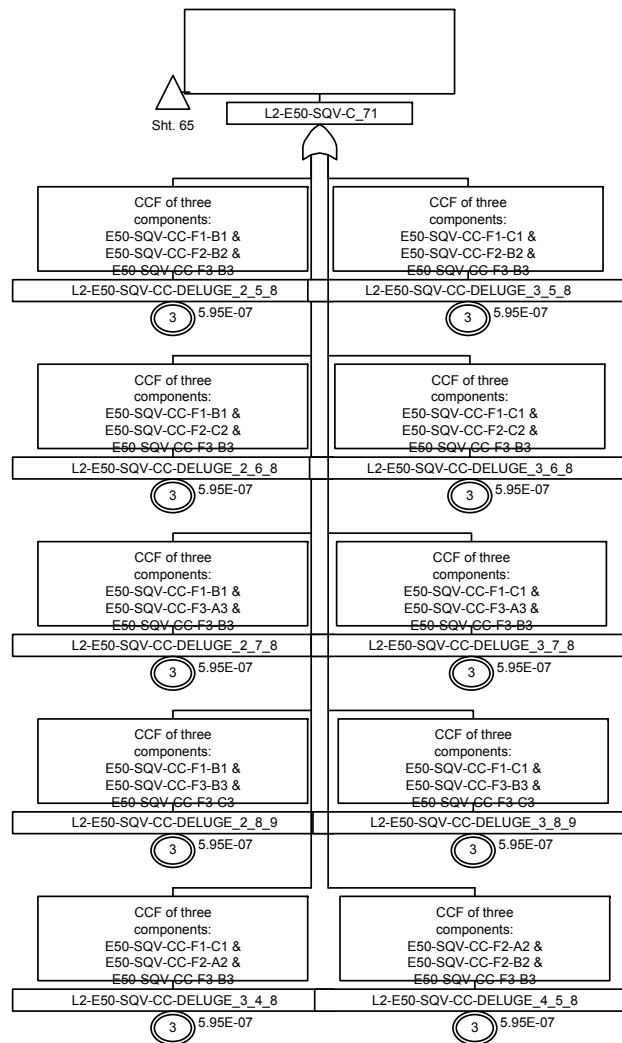

Figure 8A-8. Level 2 Fault Trees

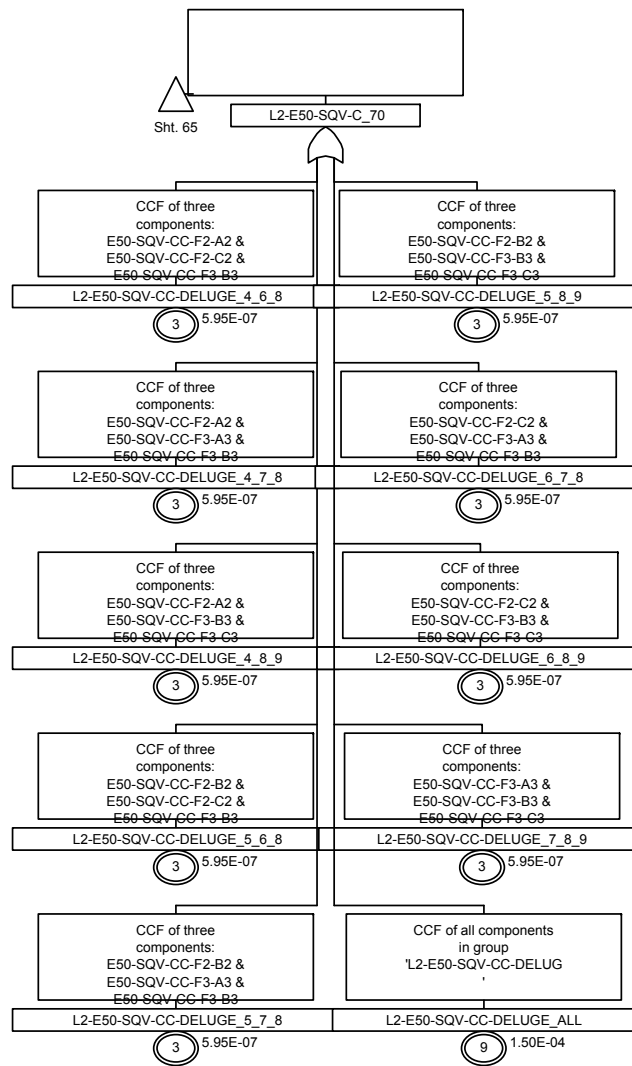

Figure 8A-8. Level 2 Fault Trees

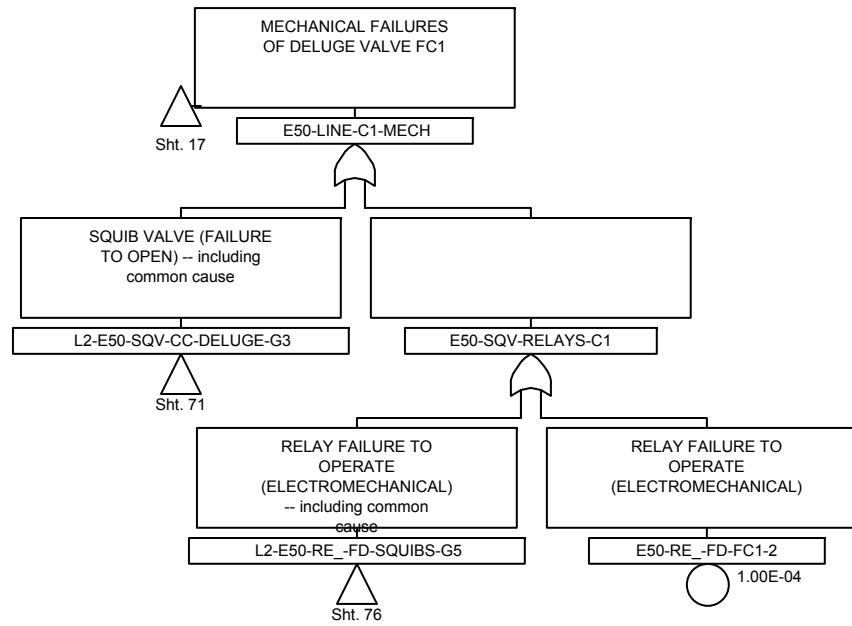

Figure 8A-8. Level 2 Fault Trees

Sheet 70 of 147

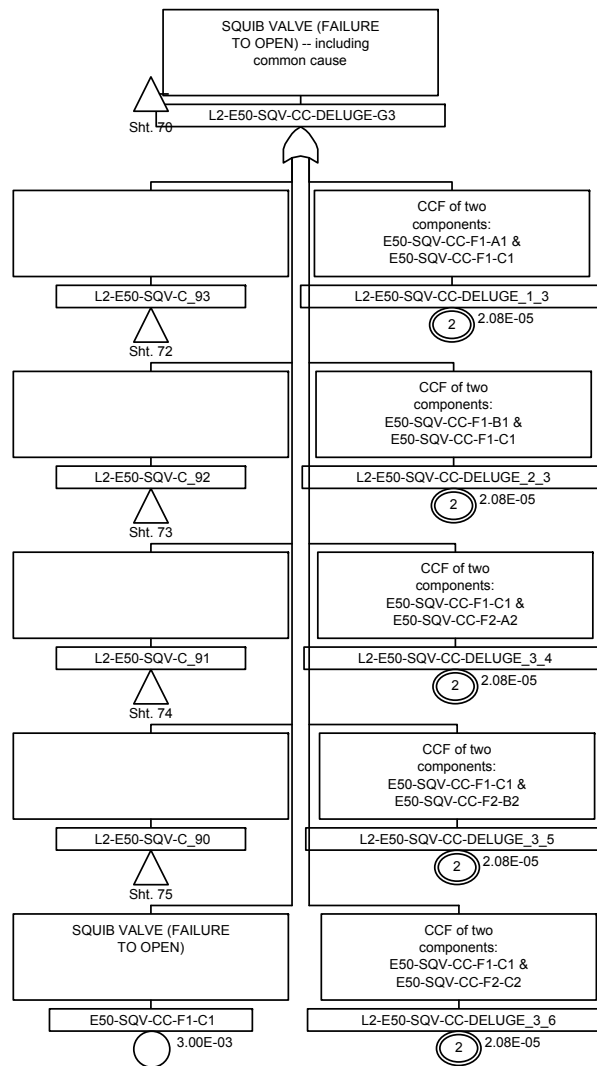

Figure 8A-8. Level 2 Fault Trees

Sheet 71 of 147

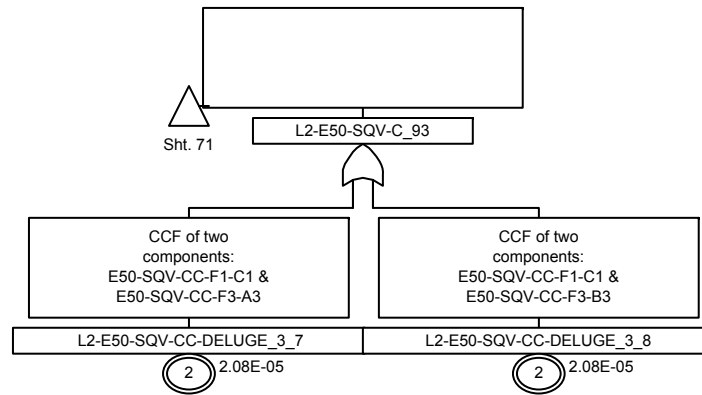

Figure 8A-8. Level 2 Fault Trees

Sheet 72 of 147

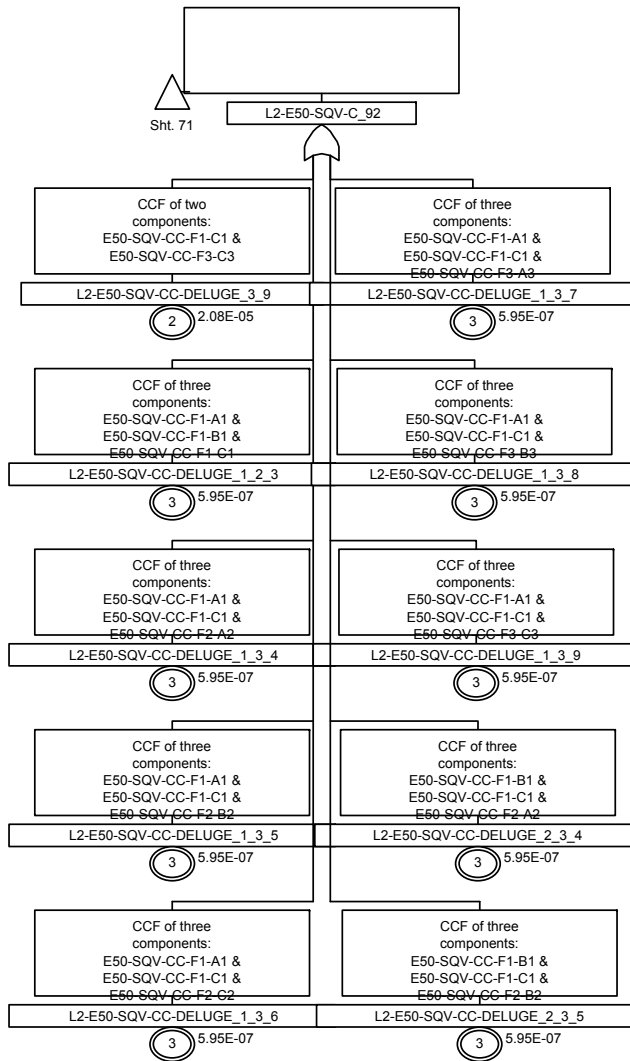

Figure 8A-8. Level 2 Fault Trees

Sheet 73 of 147

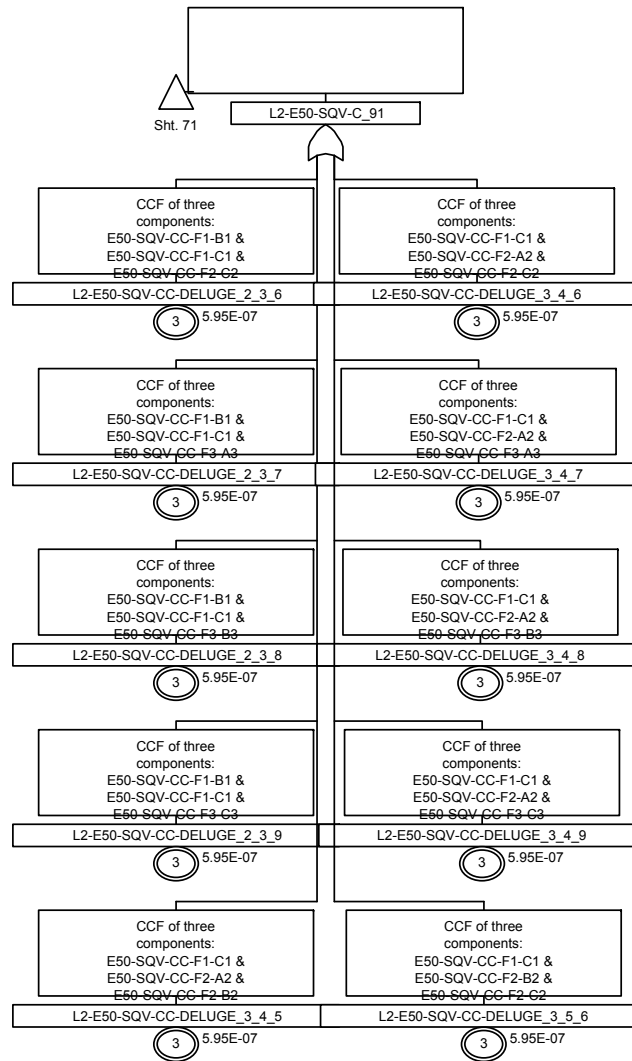

Figure 8A-8. Level 2 Fault Trees

Sheet 74 of 147

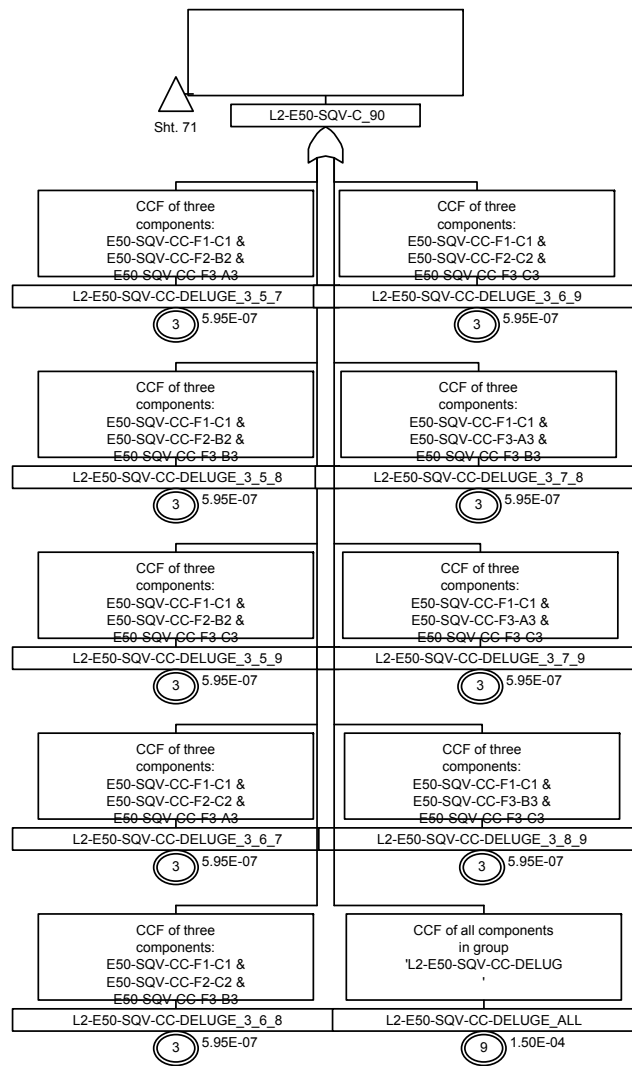

Figure 8A-8. Level 2 Fault Trees

Sheet 75 of 147

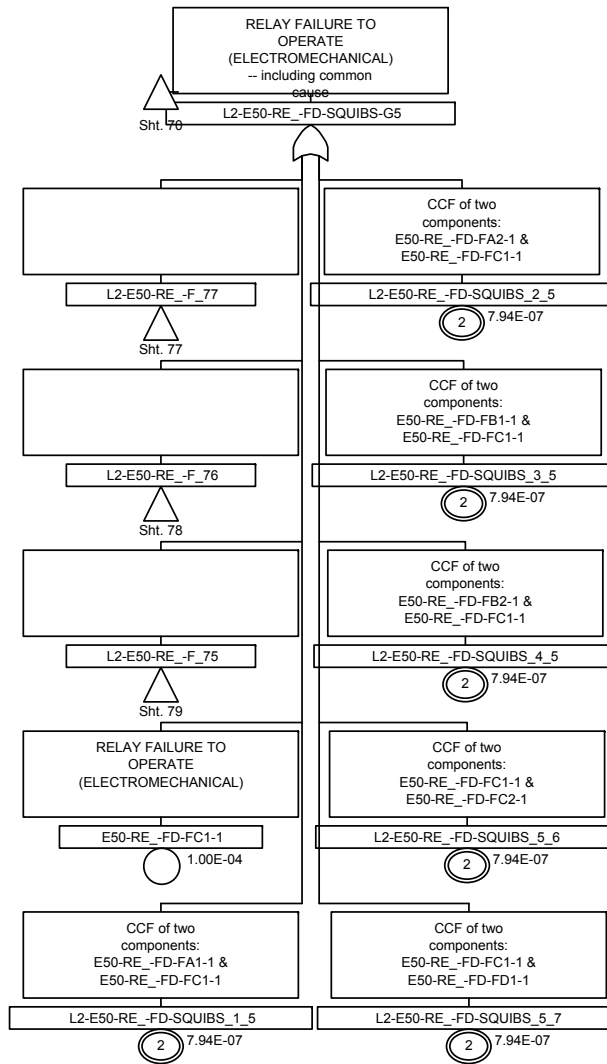

Figure 8A-8. Level 2 Fault Trees

Sheet 76 of 147

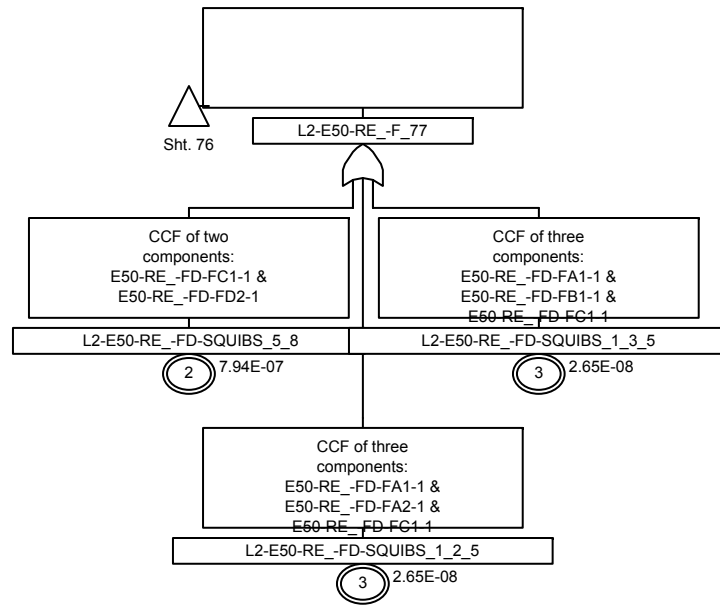

Figure 8A-8. Level 2 Fault Trees

Sheet 77 of 147

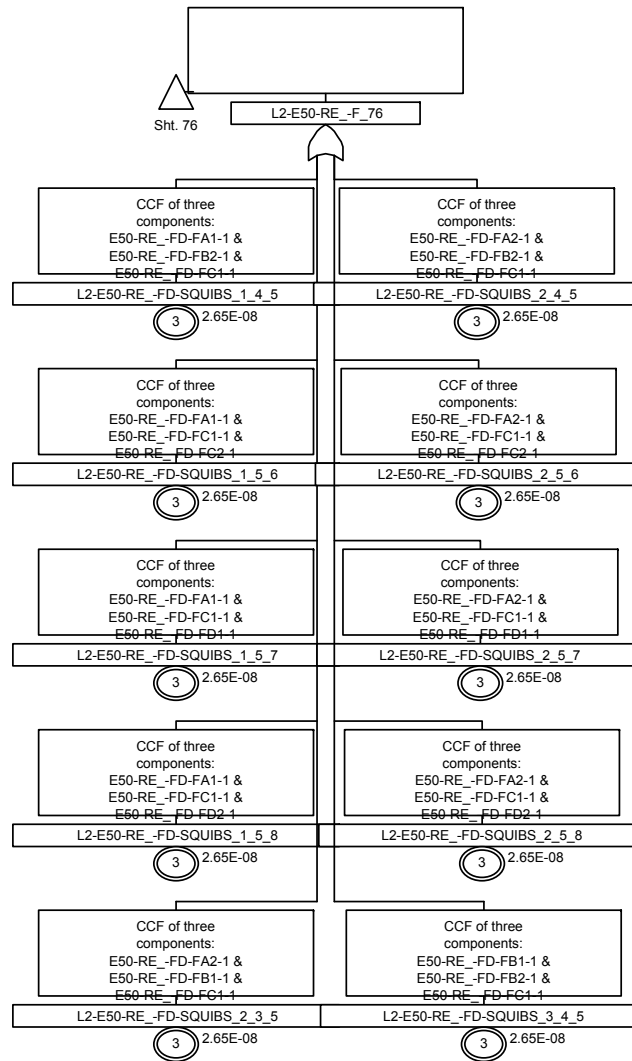

Figure 8A-8. Level 2 Fault Trees

Sheet 78 of 147

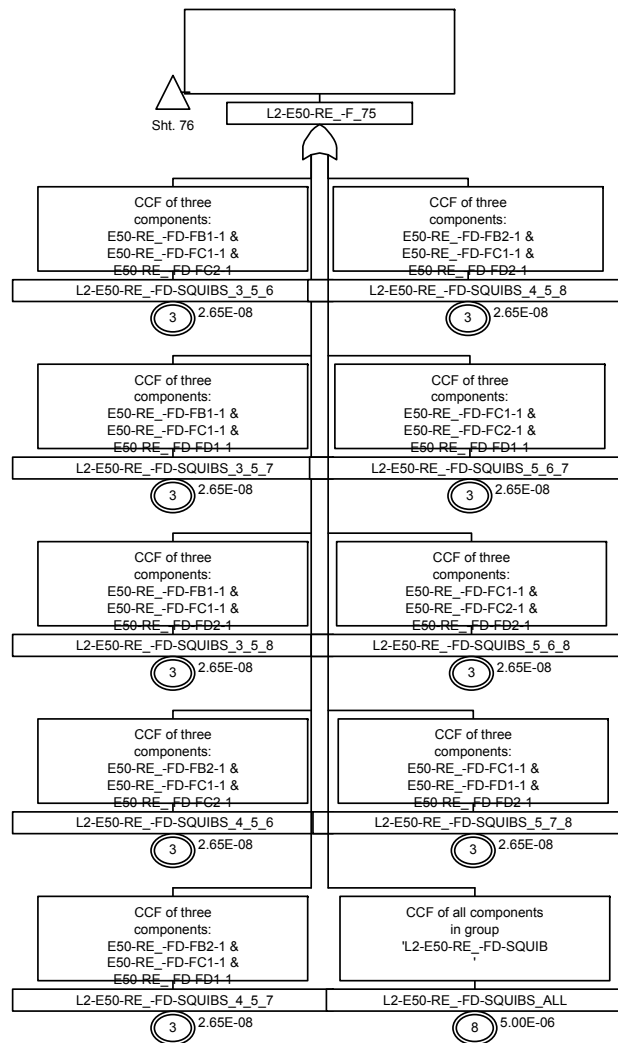

Figure 8A-8. Level 2 Fault Trees

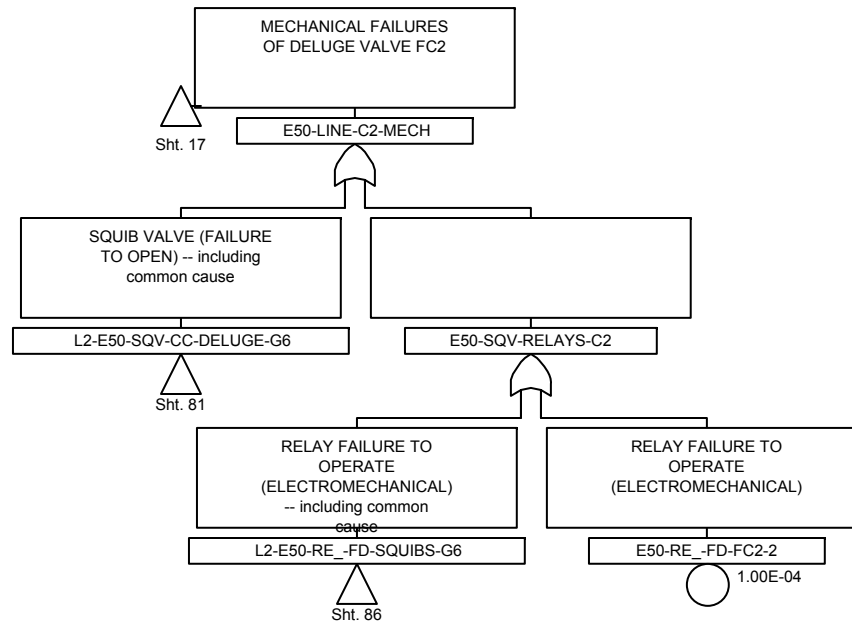

Figure 8A-8. Level 2 Fault Trees

Sheet 80 of 147

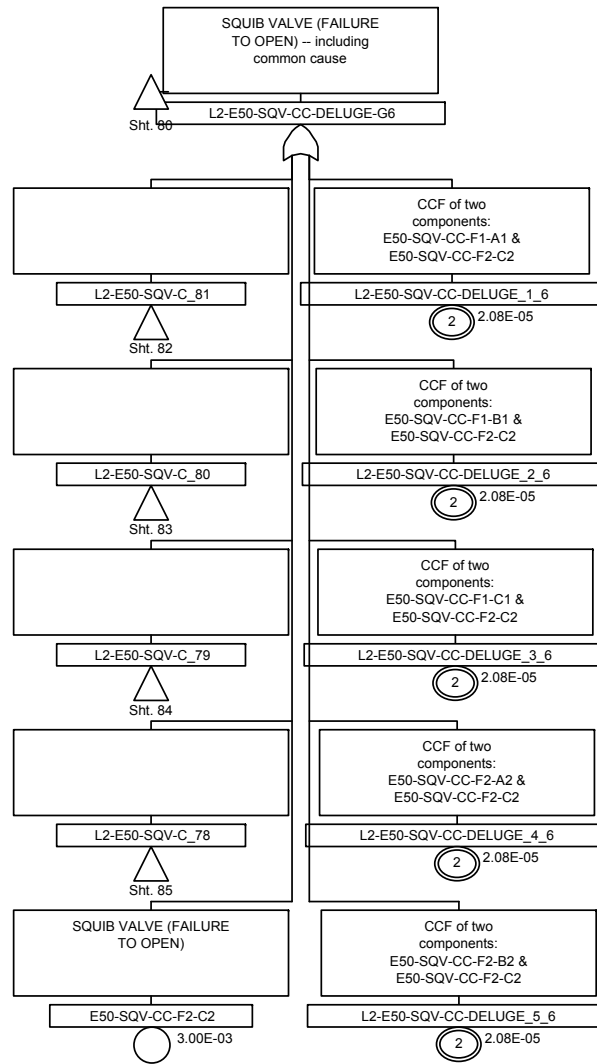

Figure 8A-8. Level 2 Fault Trees

Sheet 81 of 147

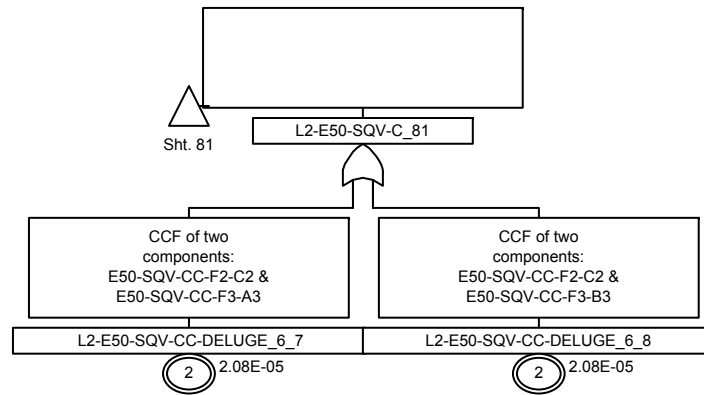

Figure 8A-8. Level 2 Fault Trees

Sheet 82 of 147

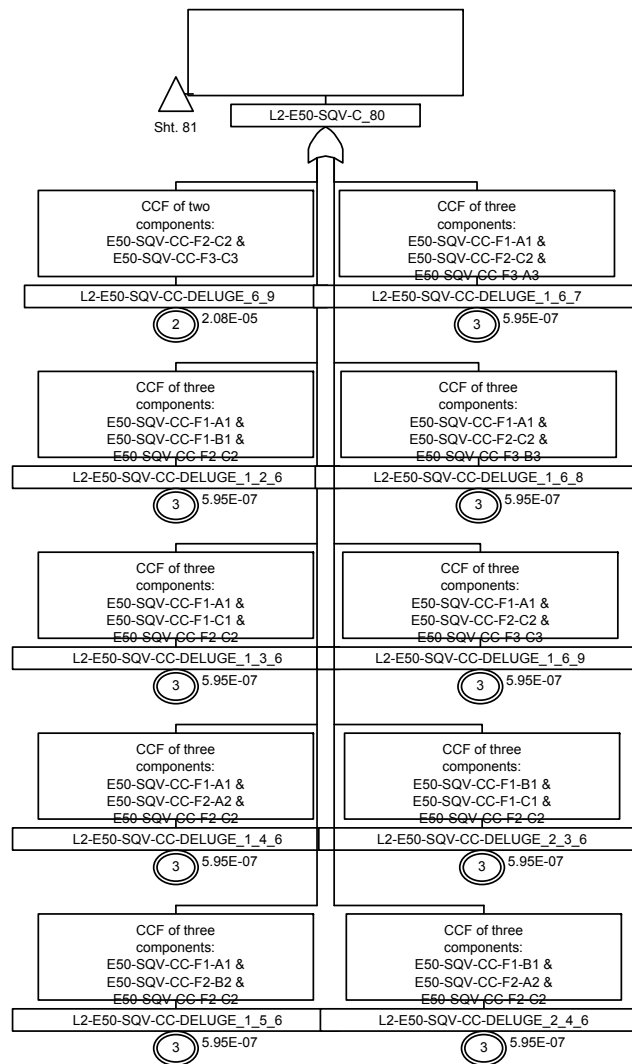

Figure 8A-8. Level 2 Fault Trees

Sheet 83 of 147

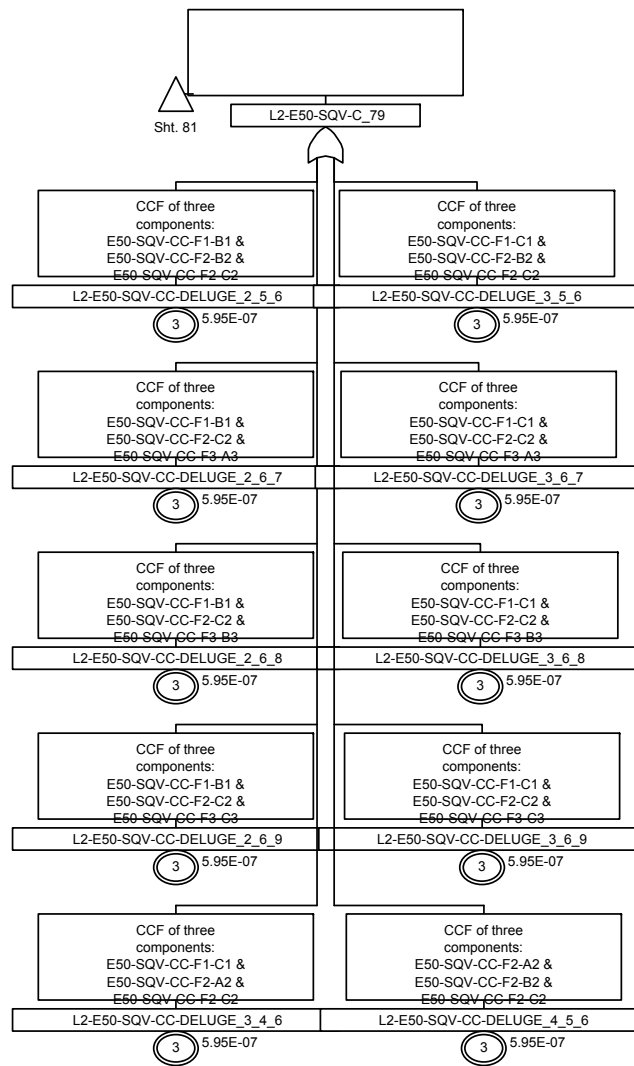

Figure 8A-8. Level 2 Fault Trees

Sheet 84 of 147

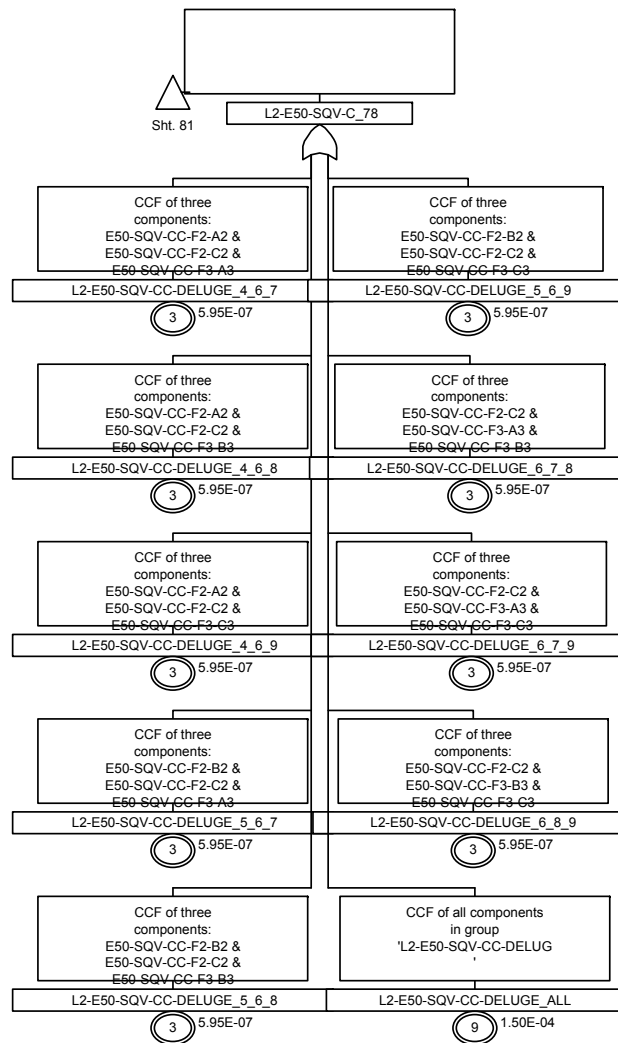

Figure 8A-8. Level 2 Fault Trees

Sheet 85 of 147

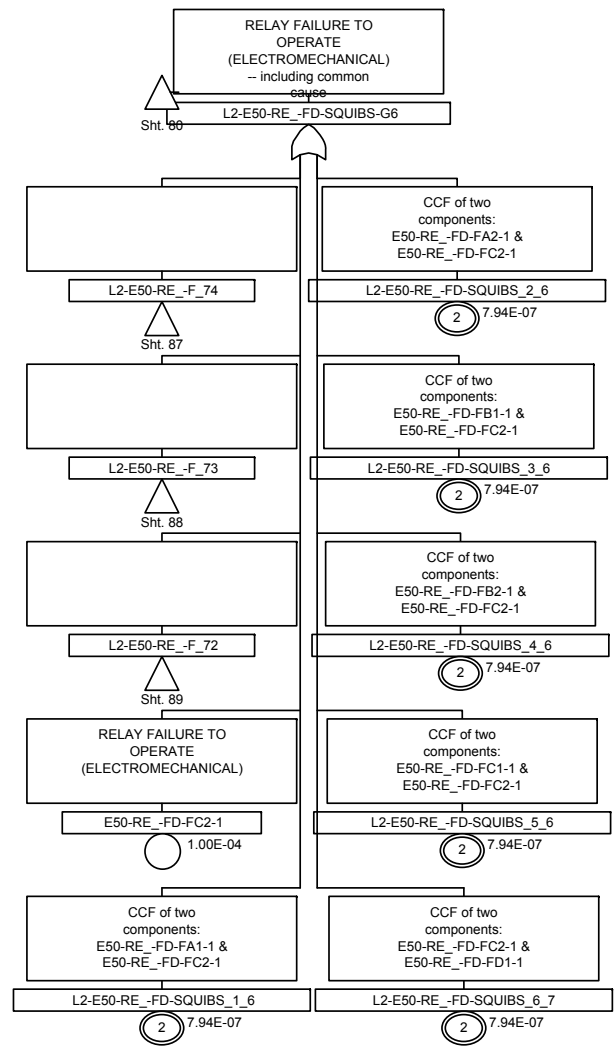

Figure 8A-8. Level 2 Fault Trees

Sheet 86 of 147

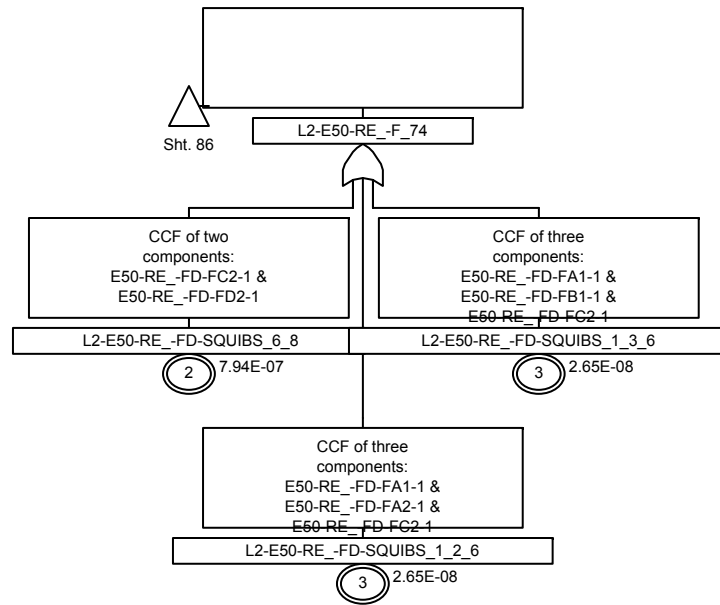

Figure 8A-8. Level 2 Fault Trees

Sheet 87 of 147

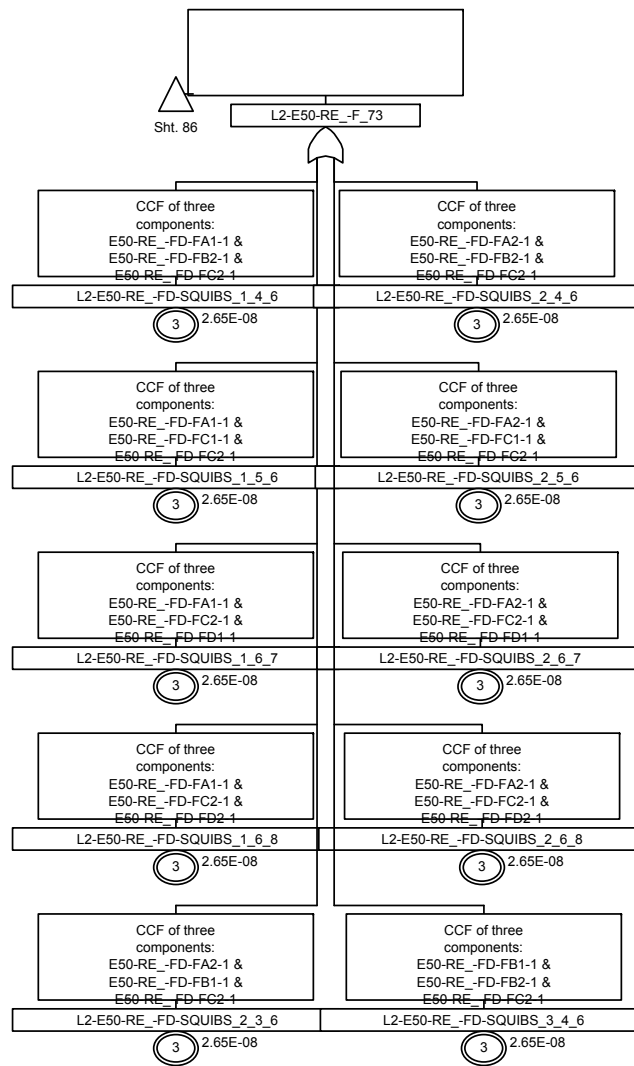

Figure 8A-8. Level 2 Fault Trees

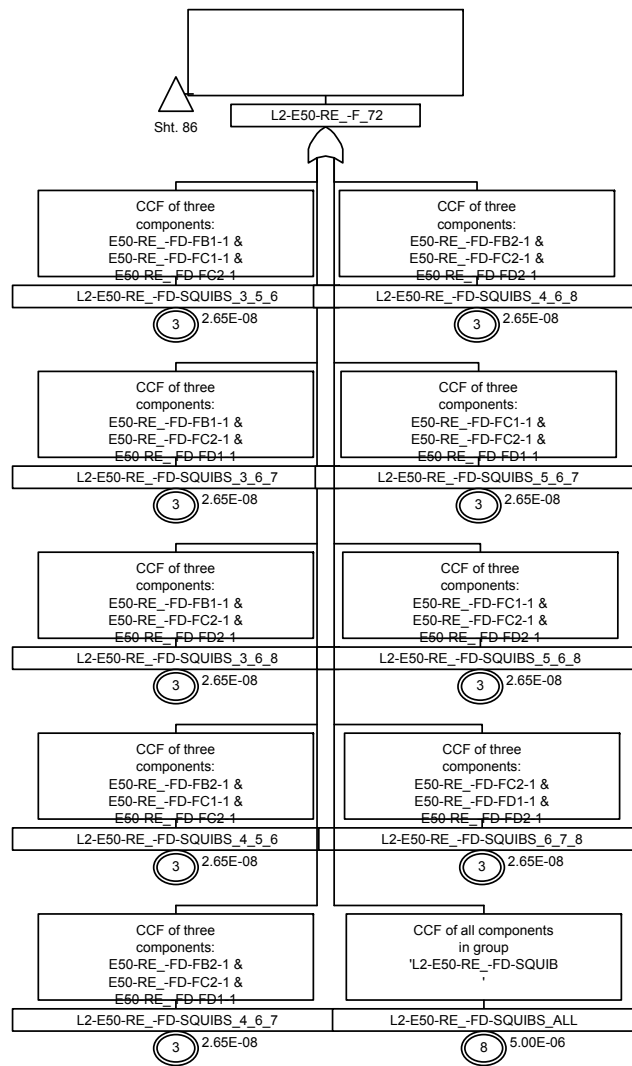

Figure 8A-8. Level 2 Fault Trees

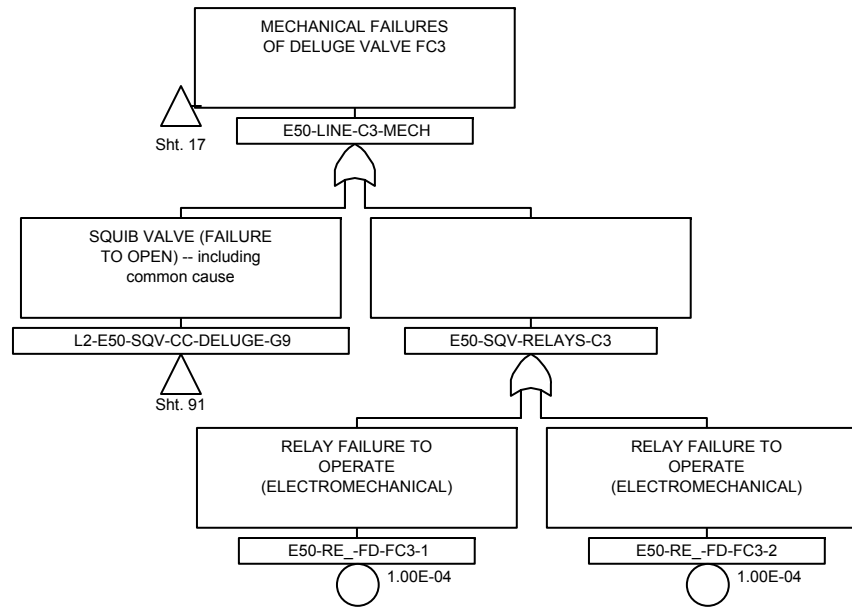

Figure 8A-8. Level 2 Fault Trees
Sheet 90 of 147

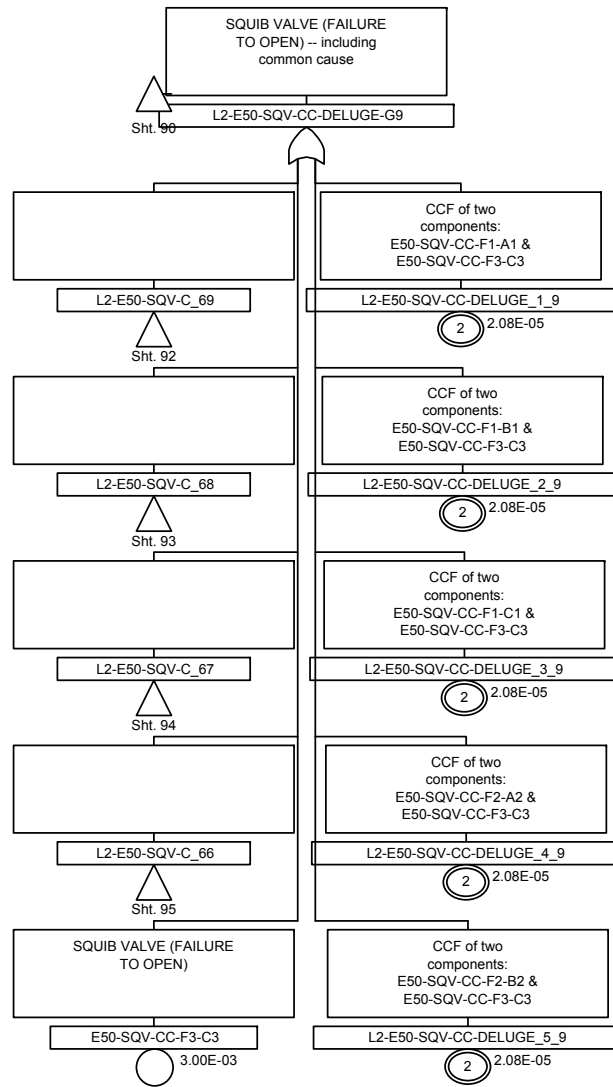

Figure 8A-8. Level 2 Fault Trees
Sheet 91 of 147

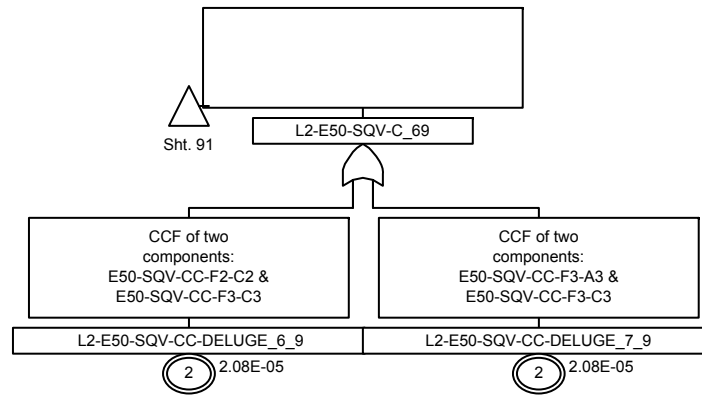

Figure 8A-8. Level 2 Fault Trees
Sheet 92 of 147

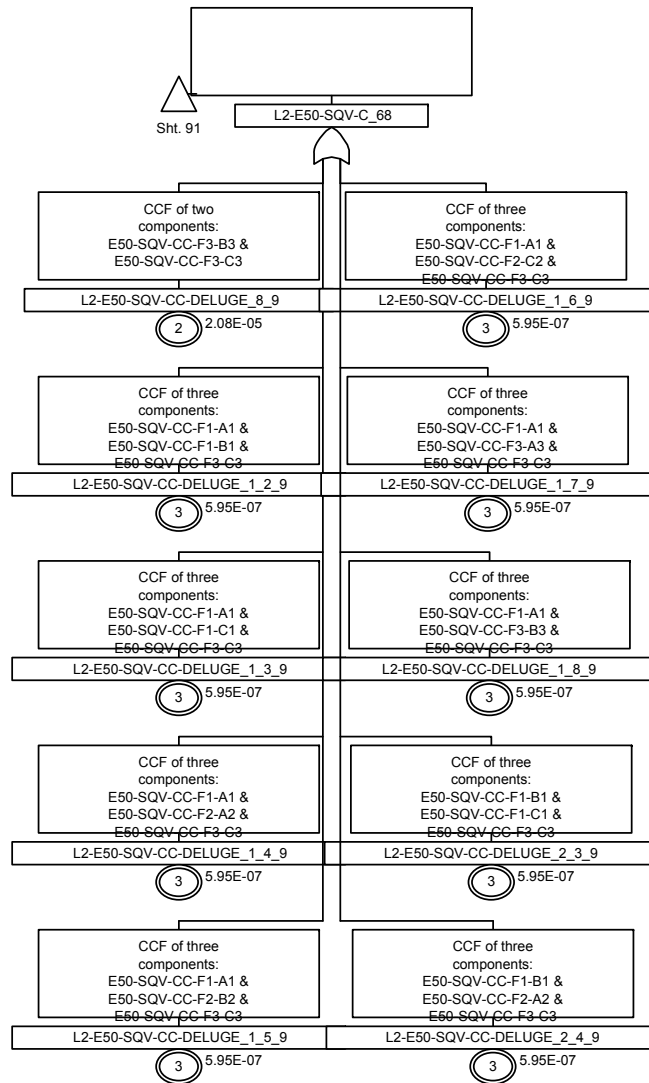

Figure 8A-8. Level 2 Fault Trees
Sheet 93 of 147

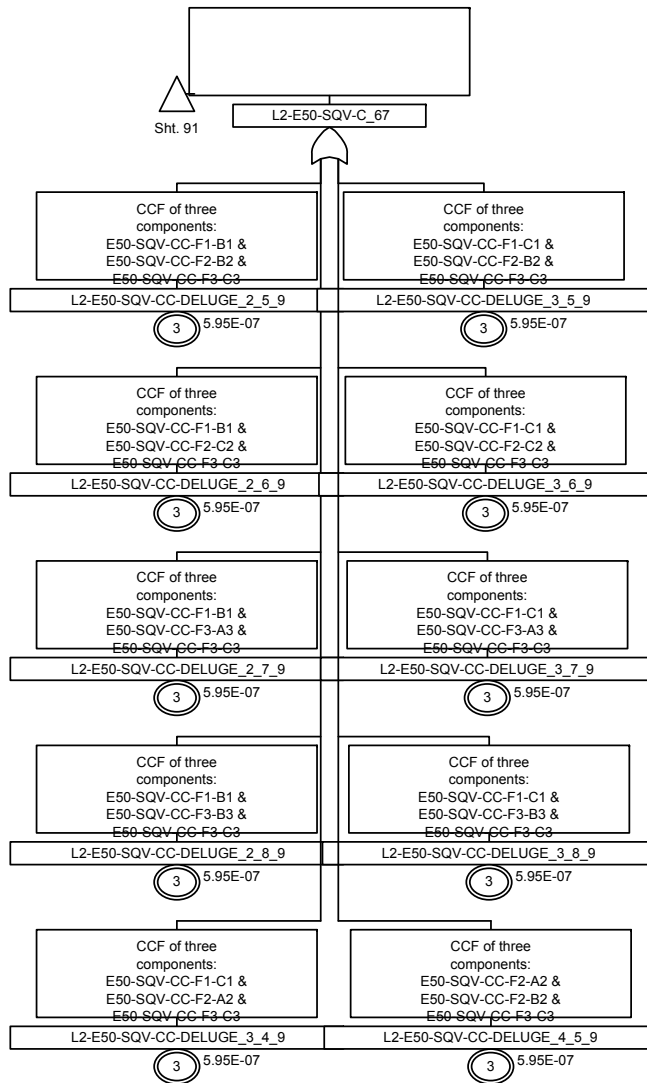

Figure 8A-8. Level 2 Fault Trees
Sheet 94 of 147

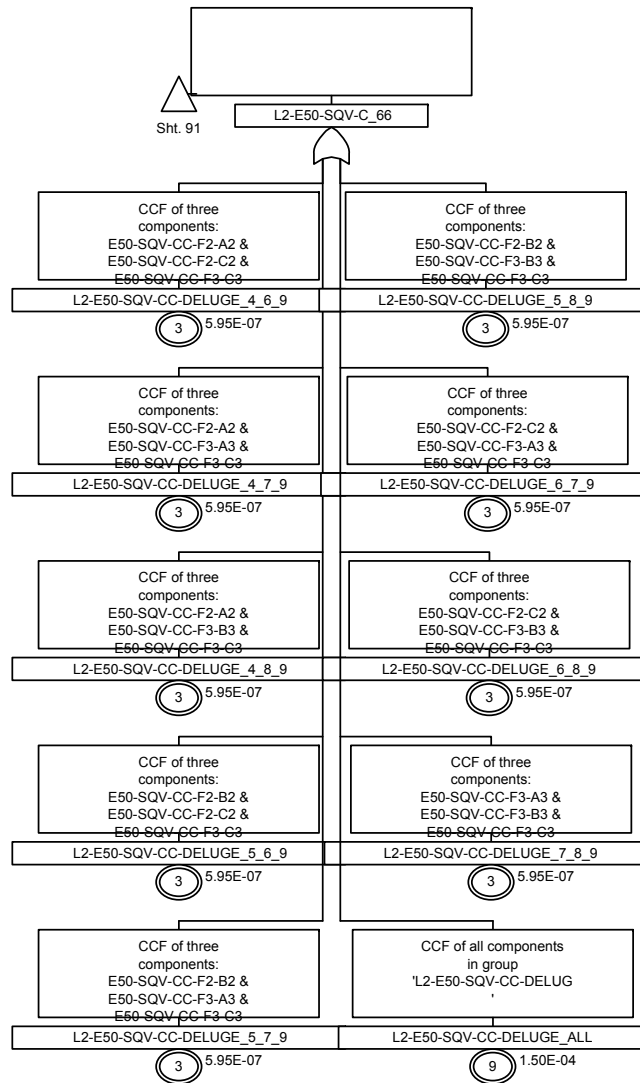

Figure 8A-8. Level 2 Fault Trees
Sheet 95 of 147

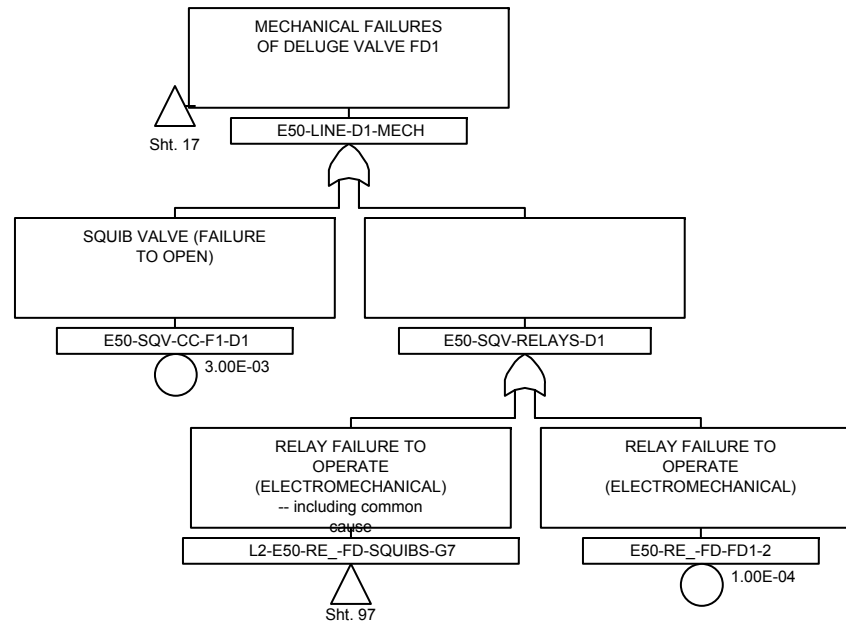

Figure 8A-8. Level 2 Fault Trees
Sheet 96 of 147

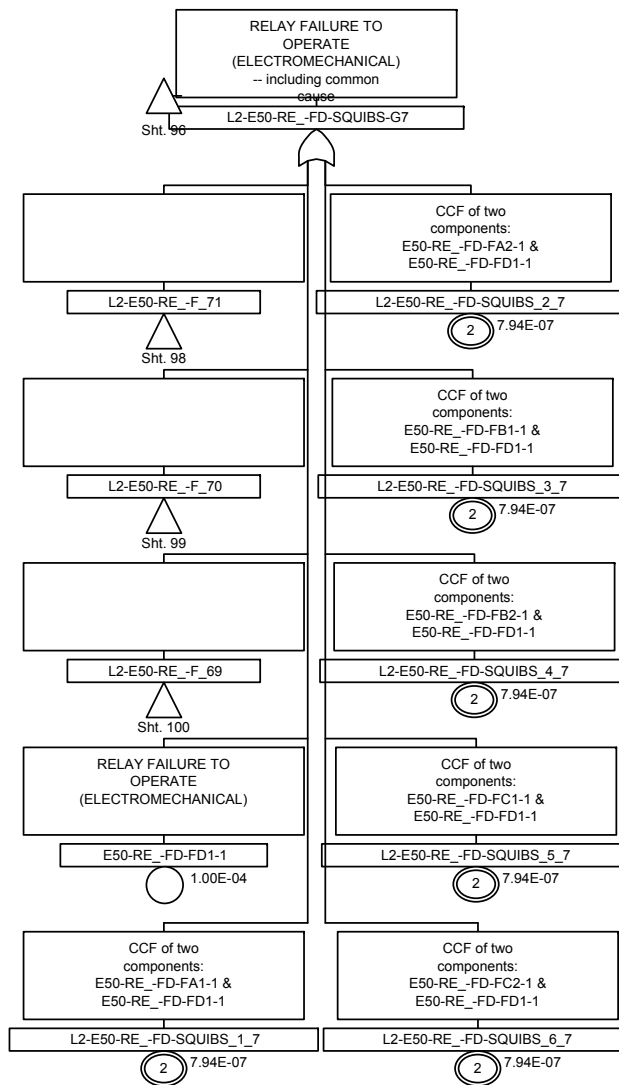

Figure 8A-8. Level 2 Fault Trees
Sheet 97 of 147

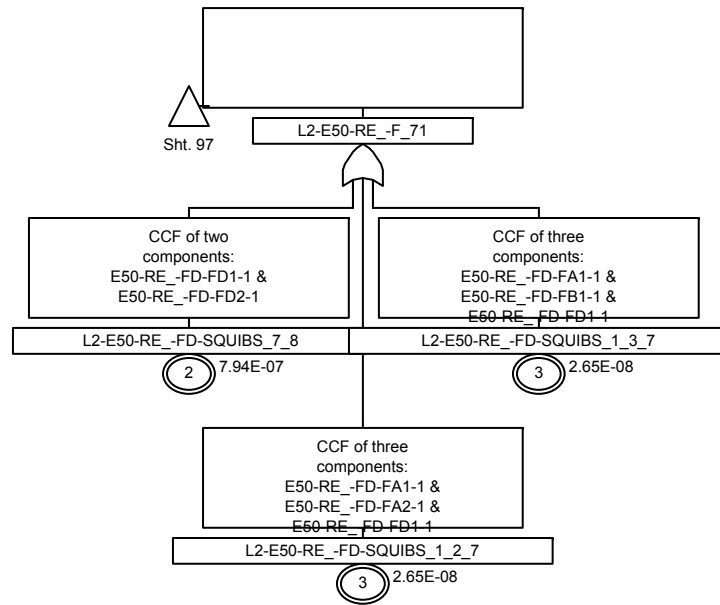

Figure 8A-8. Level 2 Fault Trees
Sheet 98 of 147

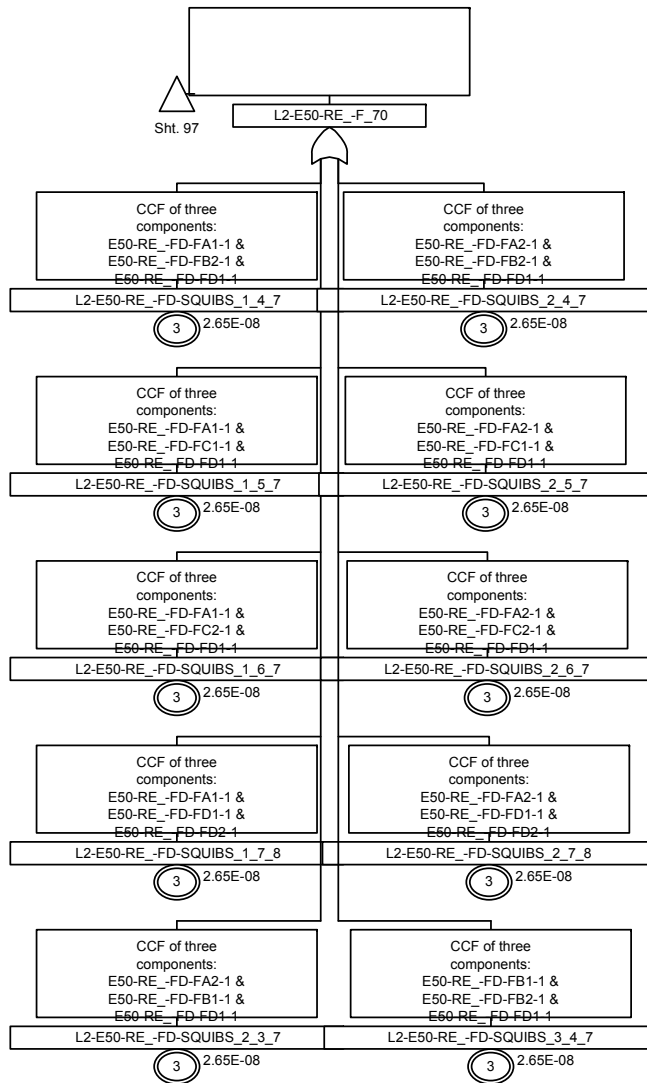

Figure 8A-8. Level 2 Fault Trees
Sheet 99 of 147

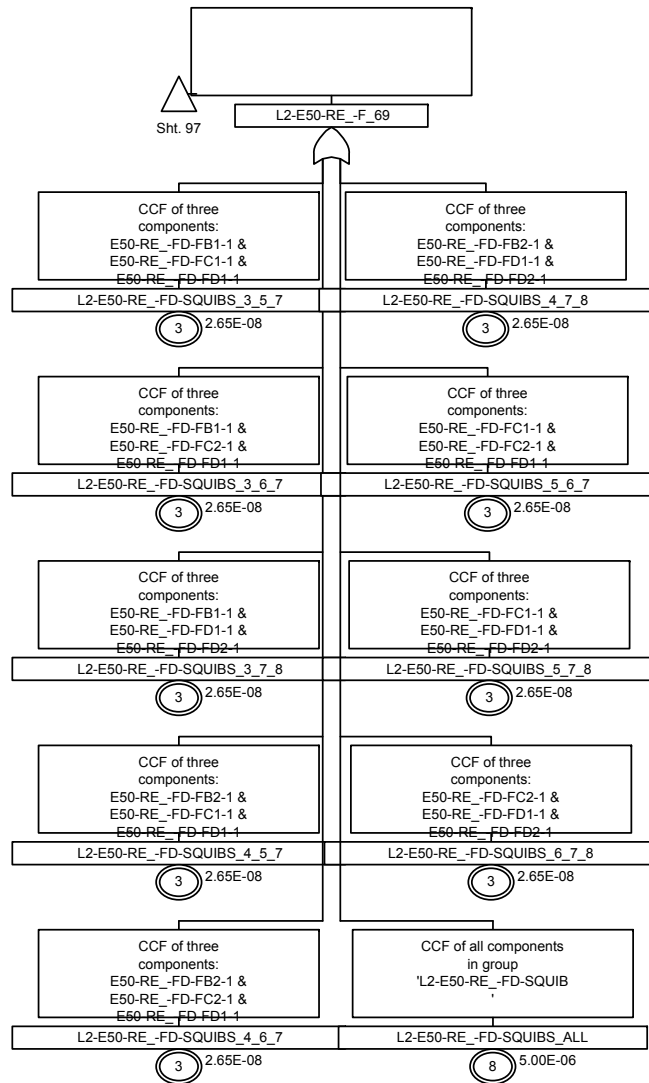

Figure 8A-8. Level 2 Fault Trees
Sheet 100 of 147

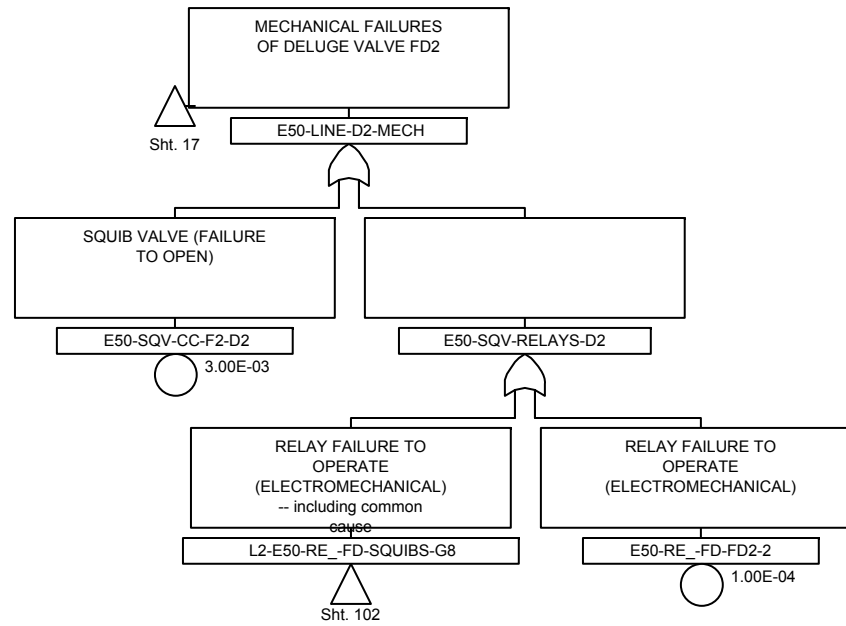

Figure 8A-8. Level 2 Fault Trees
Sheet 101 of 147

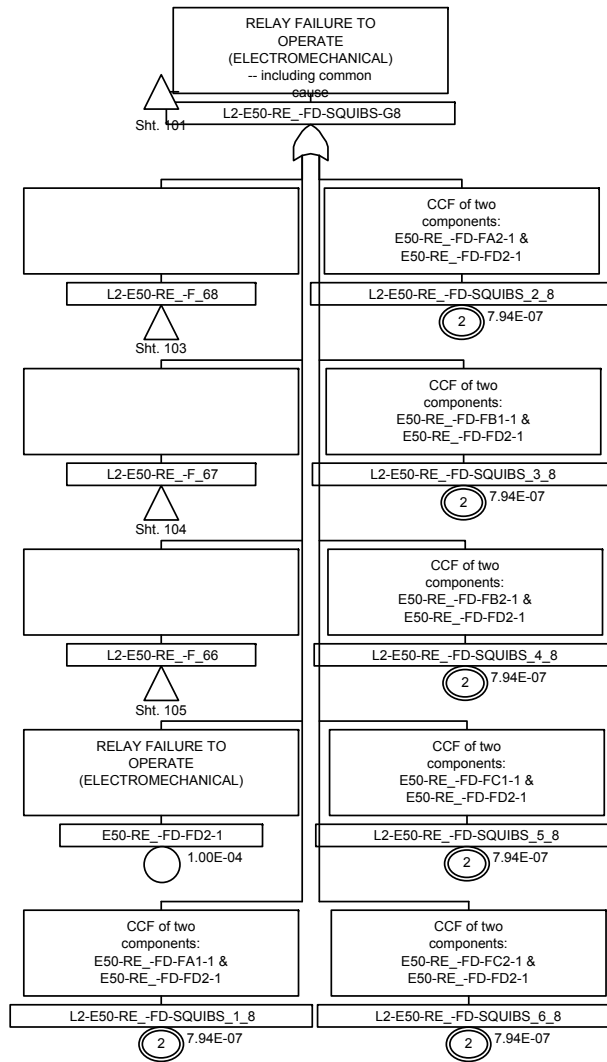

Figure 8A-8. Level 2 Fault Trees
Sheet 102 of 147

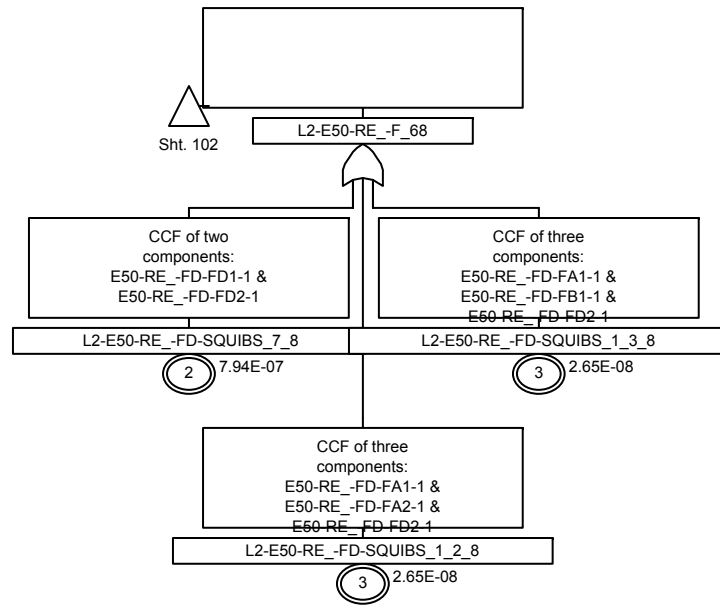

Figure 8A-8. Level 2 Fault Trees
Sheet 103 of 147

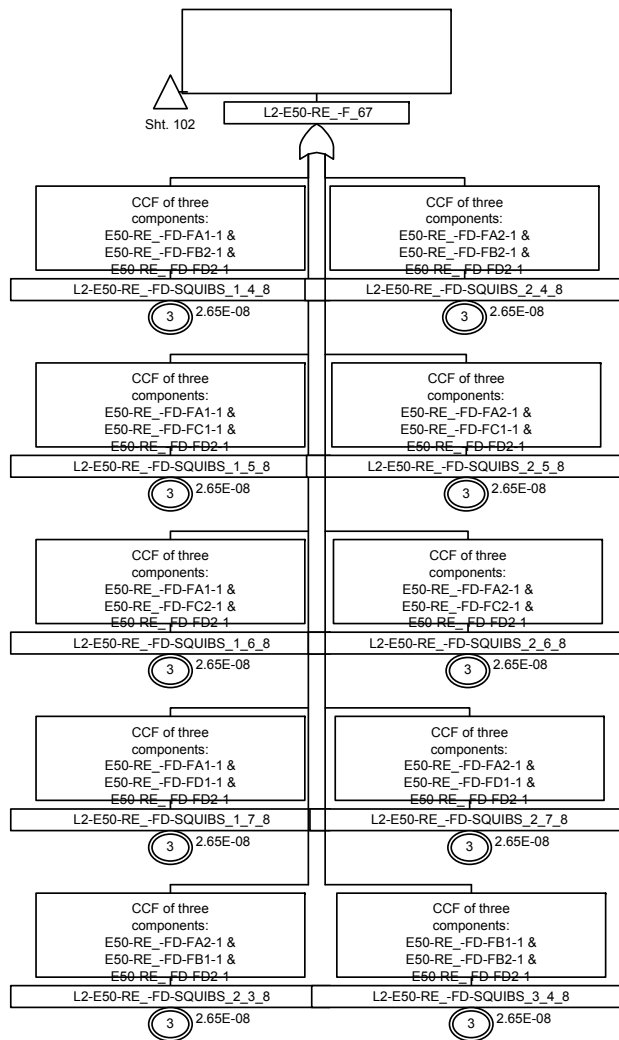

Figure 8A-8. Level 2 Fault Trees
Sheet 104 of 147

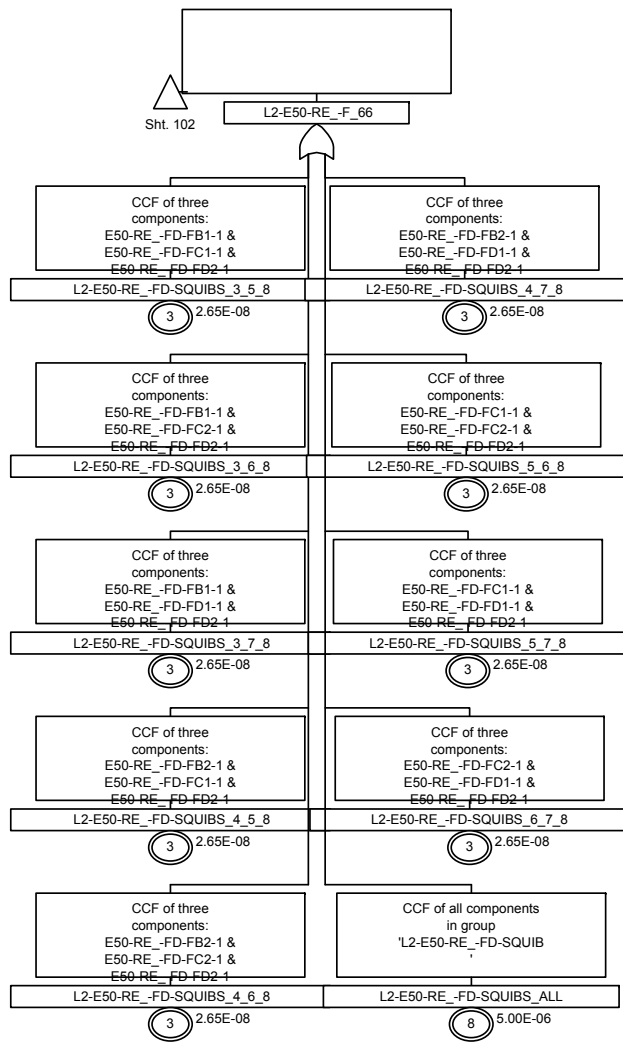

Figure 8A-8. Level 2 Fault Trees
Sheet 105 of 147

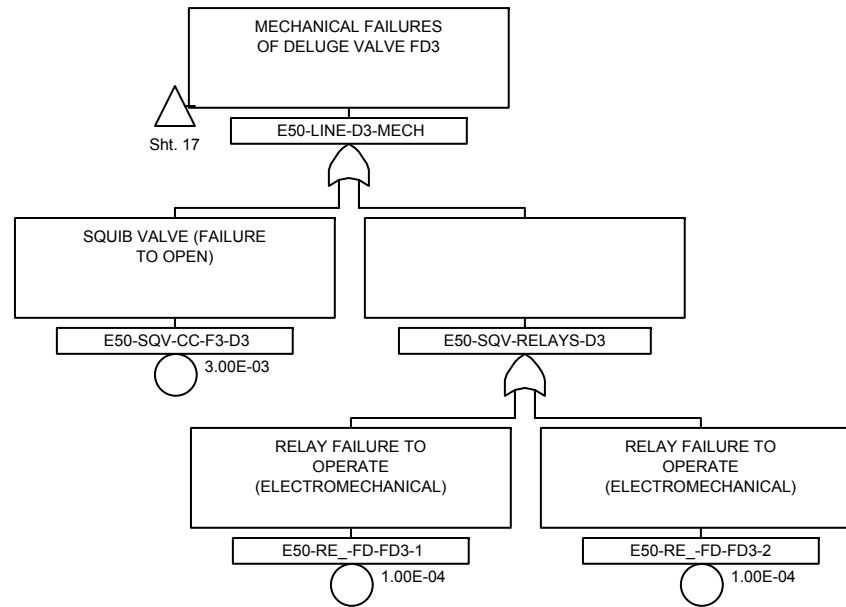

Figure 8A-8. Level 2 Fault Trees
Sheet 106 of 147

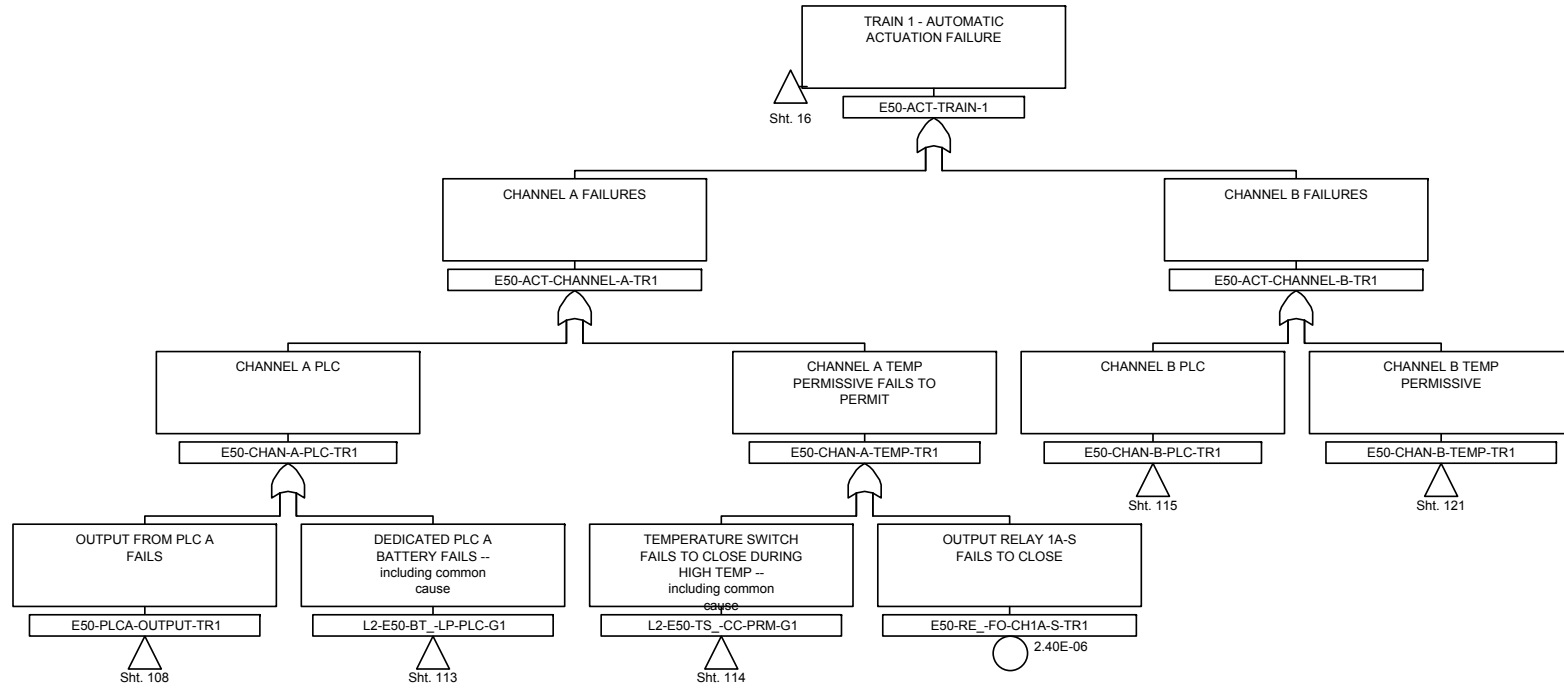

Figure 8A-8. Level 2 Fault Trees
Sheet 107 of 147

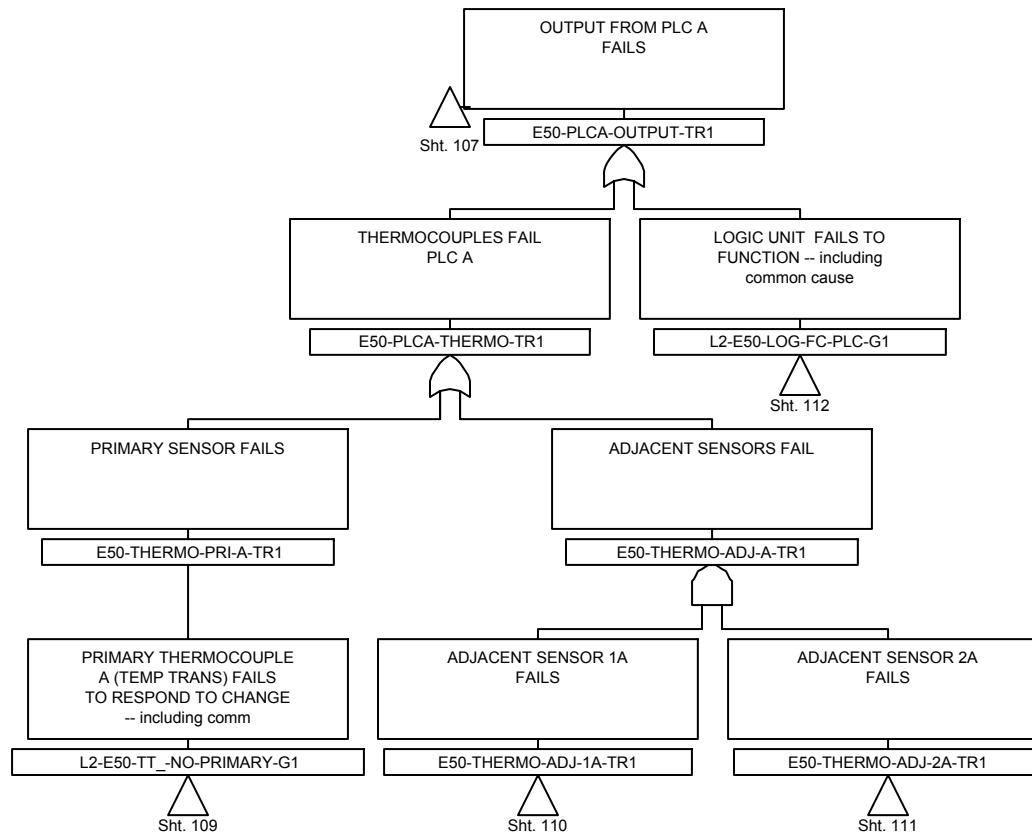

Figure 8A-8. Level 2 Fault Trees
Sheet 108 of 147

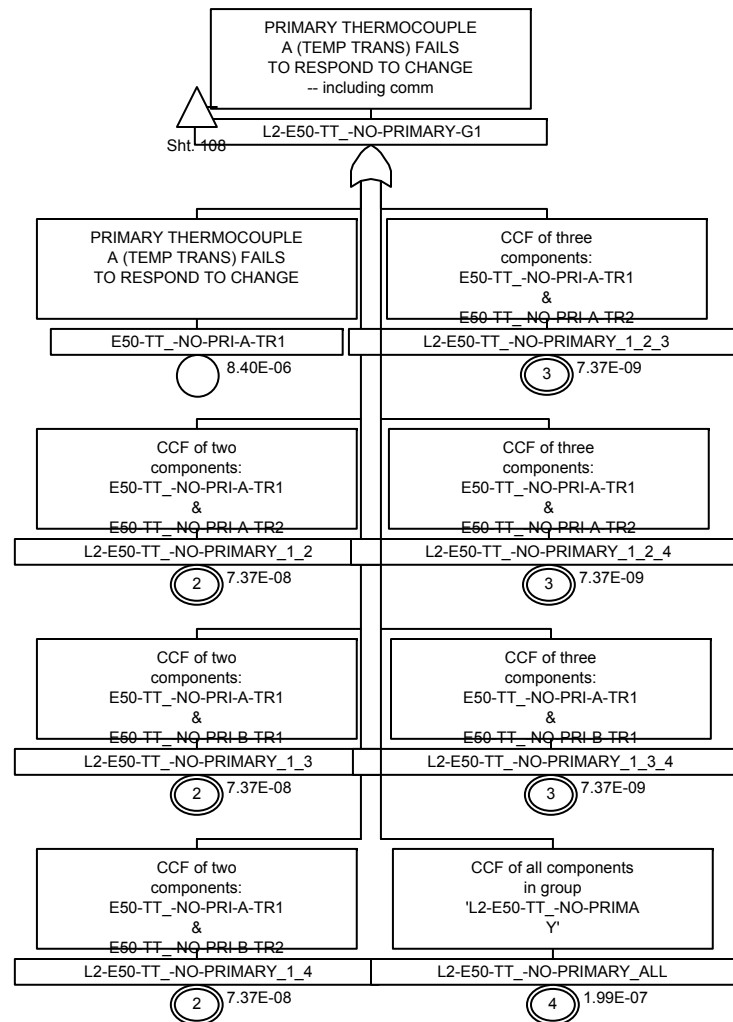

Figure 8A-8. Level 2 Fault Trees
Sheet 109 of 147

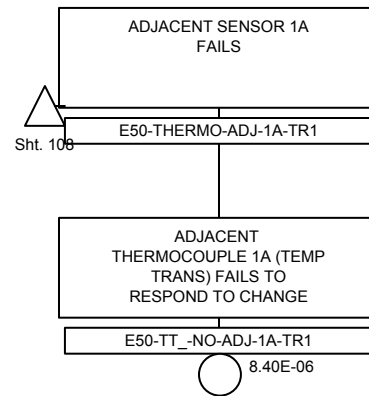

Figure 8A-8. Level 2 Fault Trees
Sheet 110 of 147

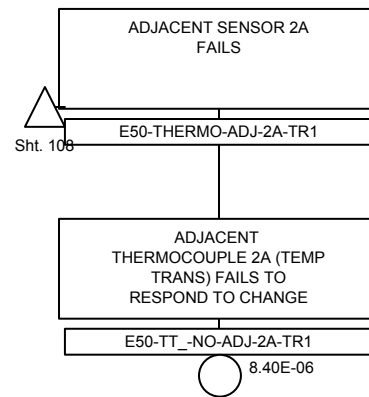

Figure 8A-8. Level 2 Fault Trees
Sheet 111 of 147

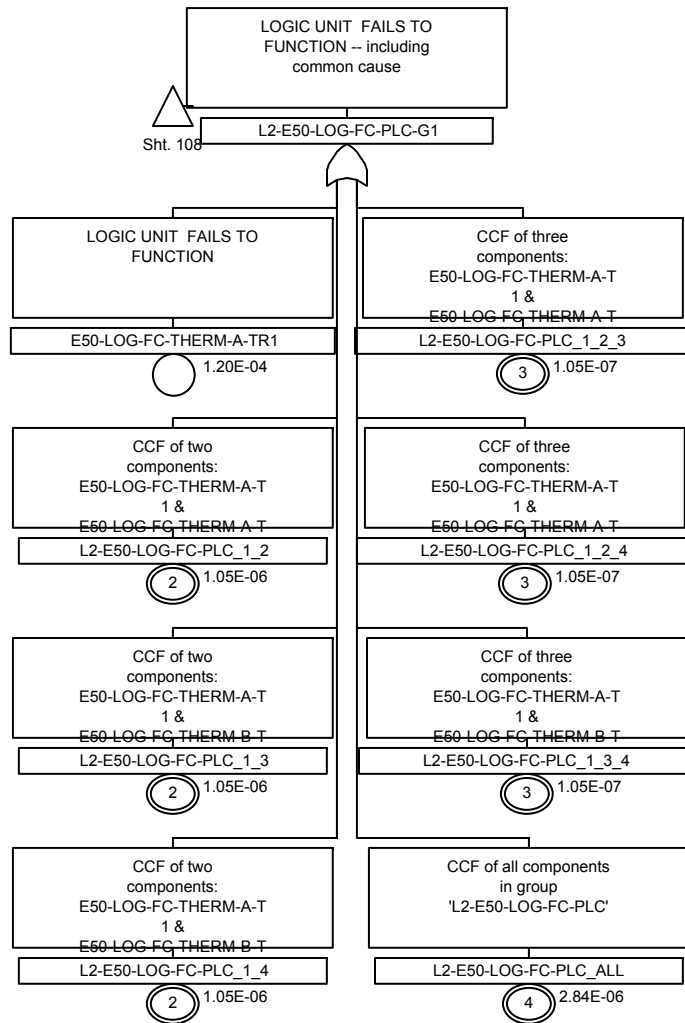

Figure 8A-8. Level 2 Fault Trees
Sheet 112 of 147

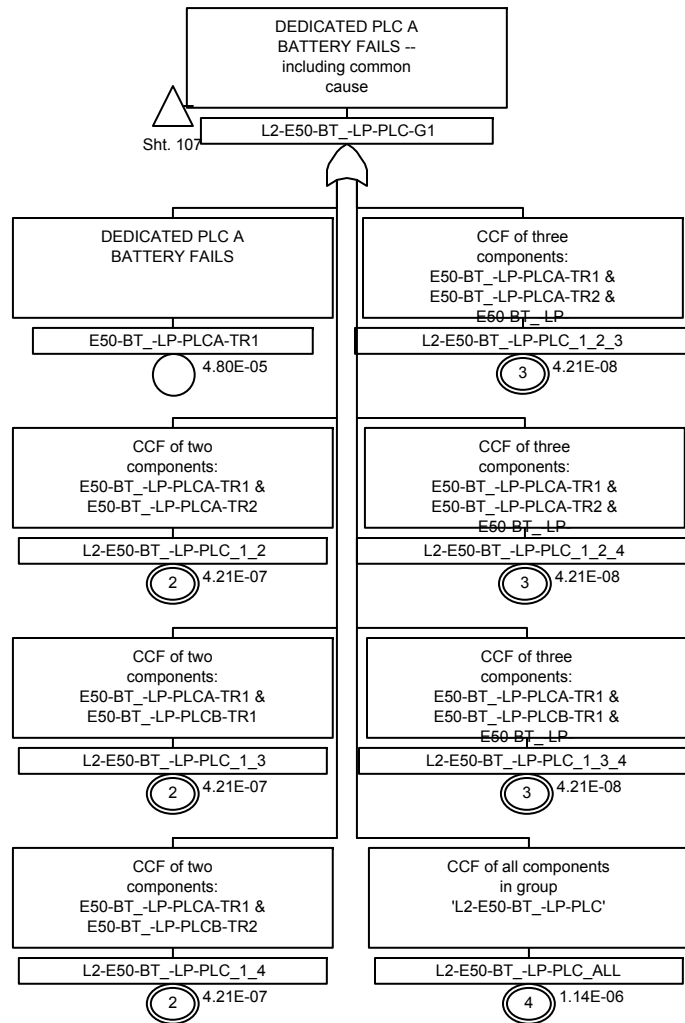

Figure 8A-8. Level 2 Fault Trees
Sheet 113 of 147

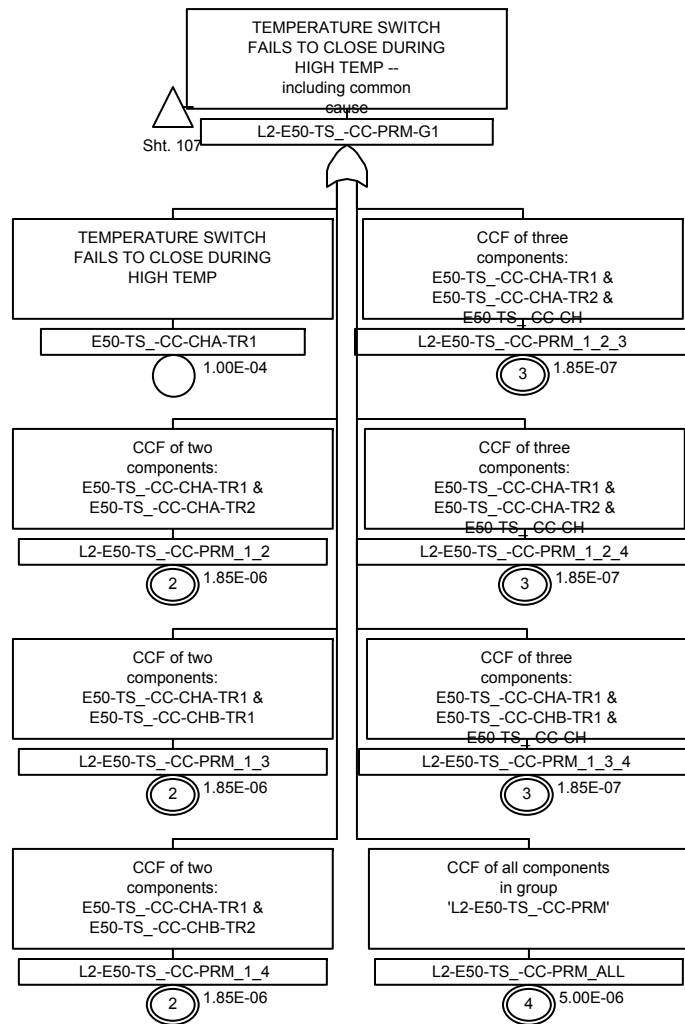

Figure 8A-8. Level 2 Fault Trees
Sheet 114 of 147

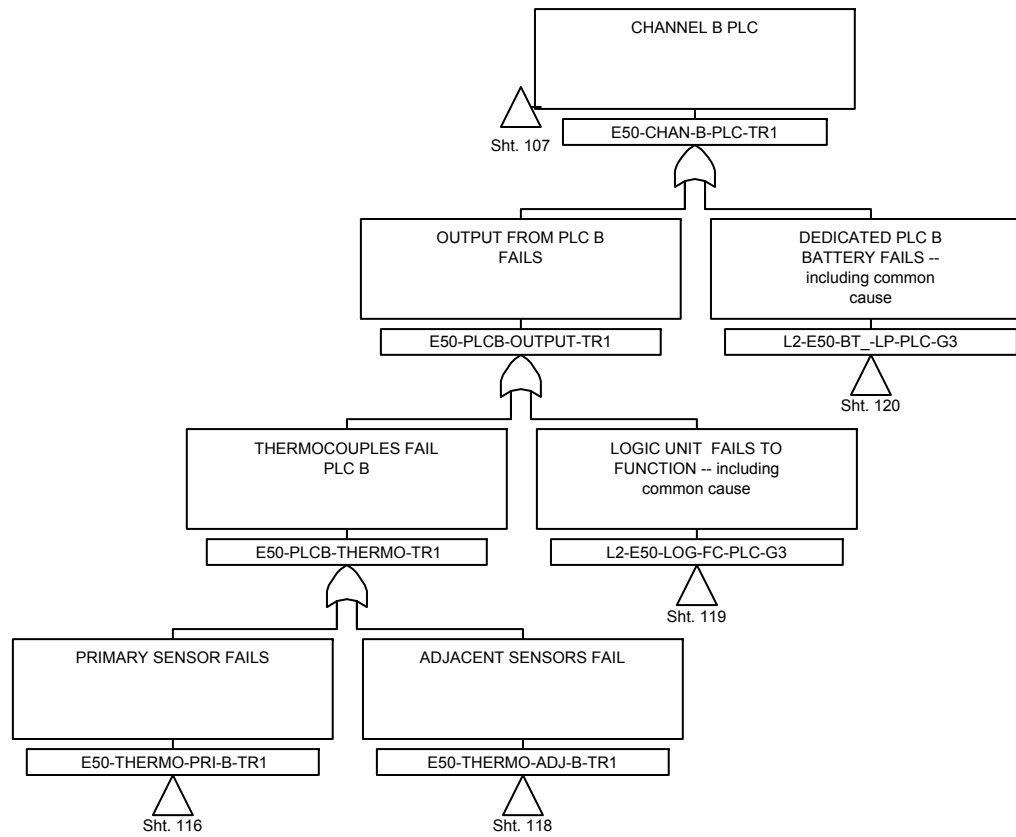

Figure 8A-8. Level 2 Fault Trees
Sheet 115 of 147

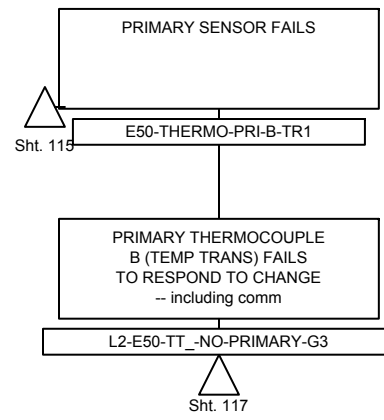

Figure 8A-8. Level 2 Fault Trees
Sheet 116 of 147

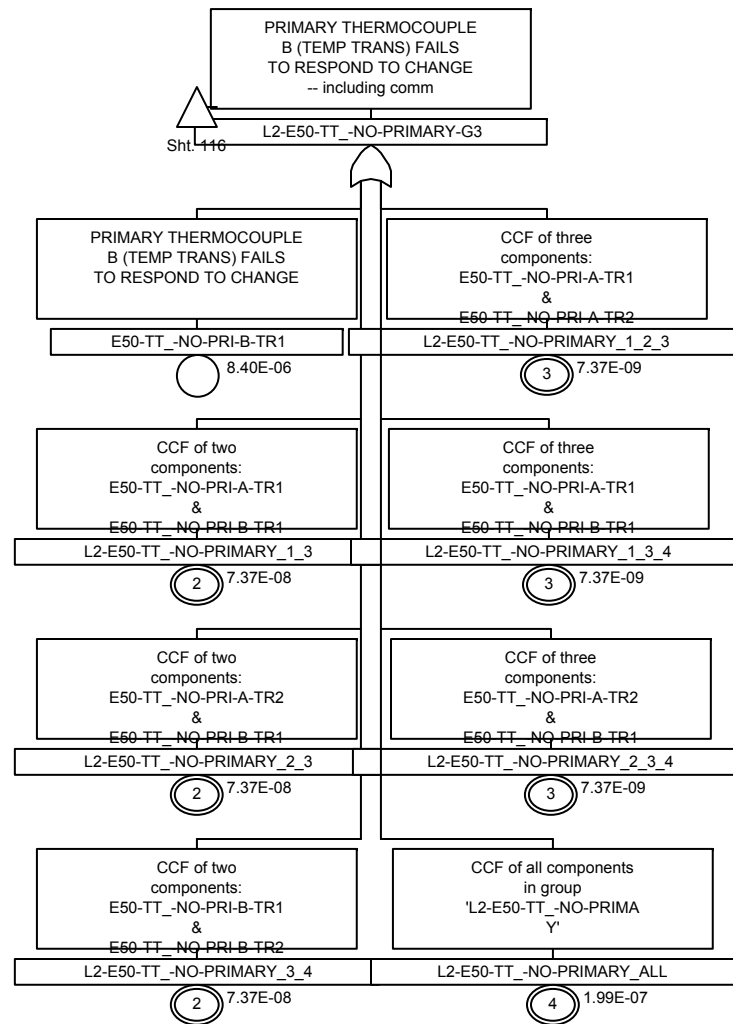

Figure 8A-8. Level 2 Fault Trees
Sheet 117 of 147

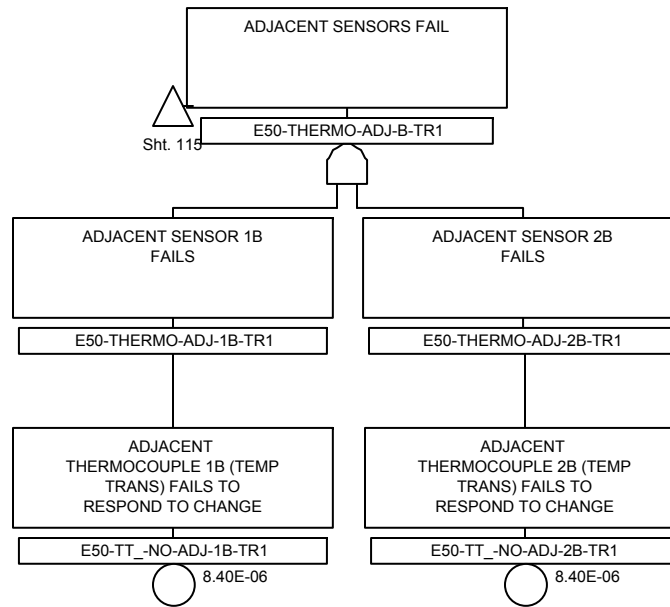

Figure 8A-8. Level 2 Fault Trees
Sheet 118 of 147

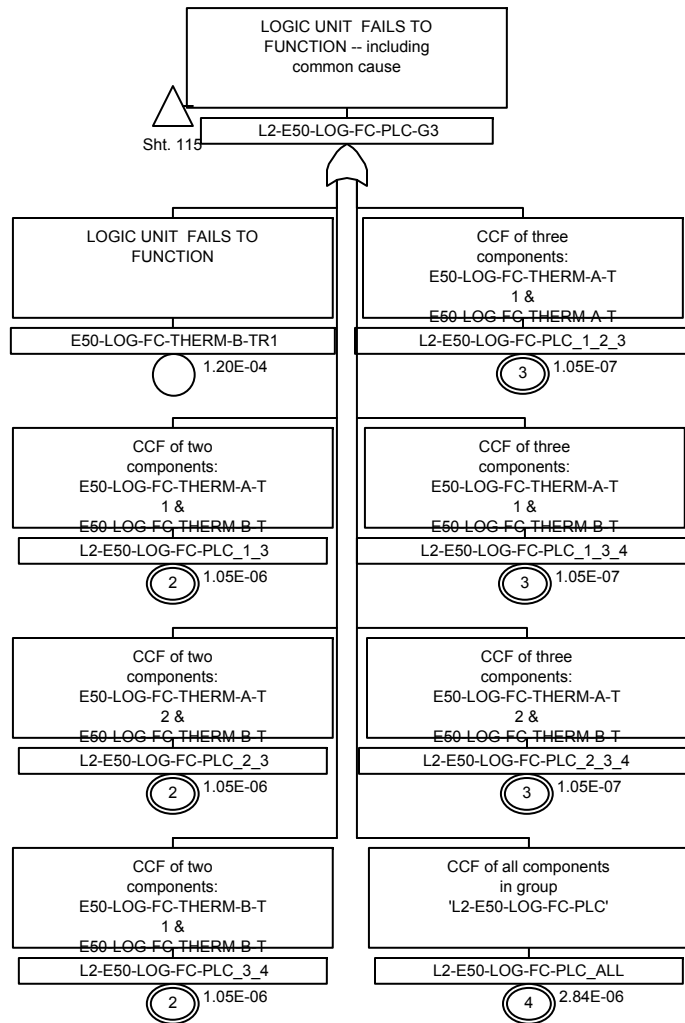

Figure 8A-8. Level 2 Fault Trees
Sheet 119 of 147

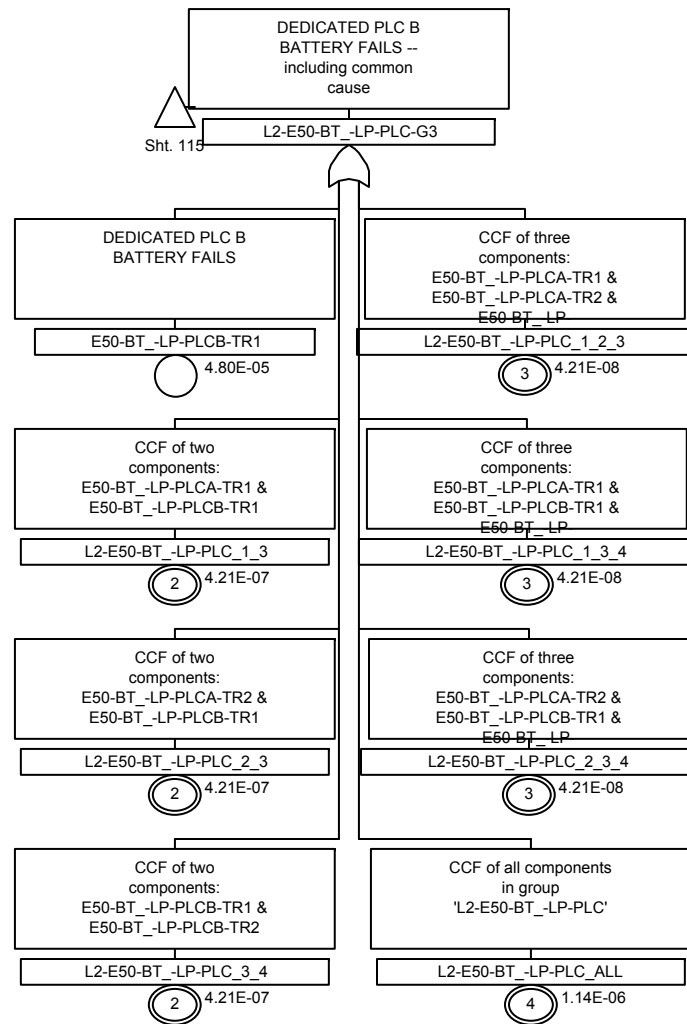

Figure 8A-8. Level 2 Fault Trees
Sheet 120 of 147

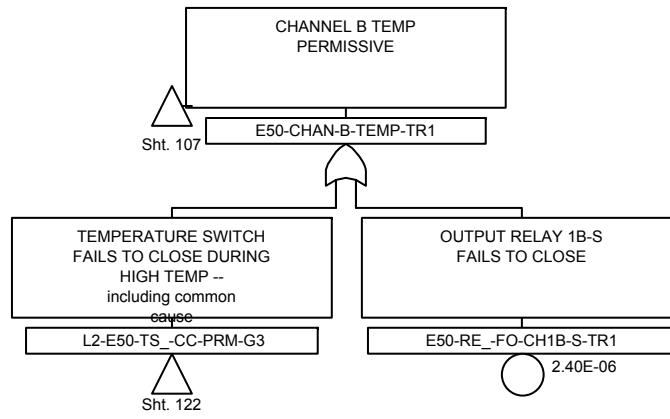

Figure 8A-8. Level 2 Fault Trees
Sheet 121 of 147

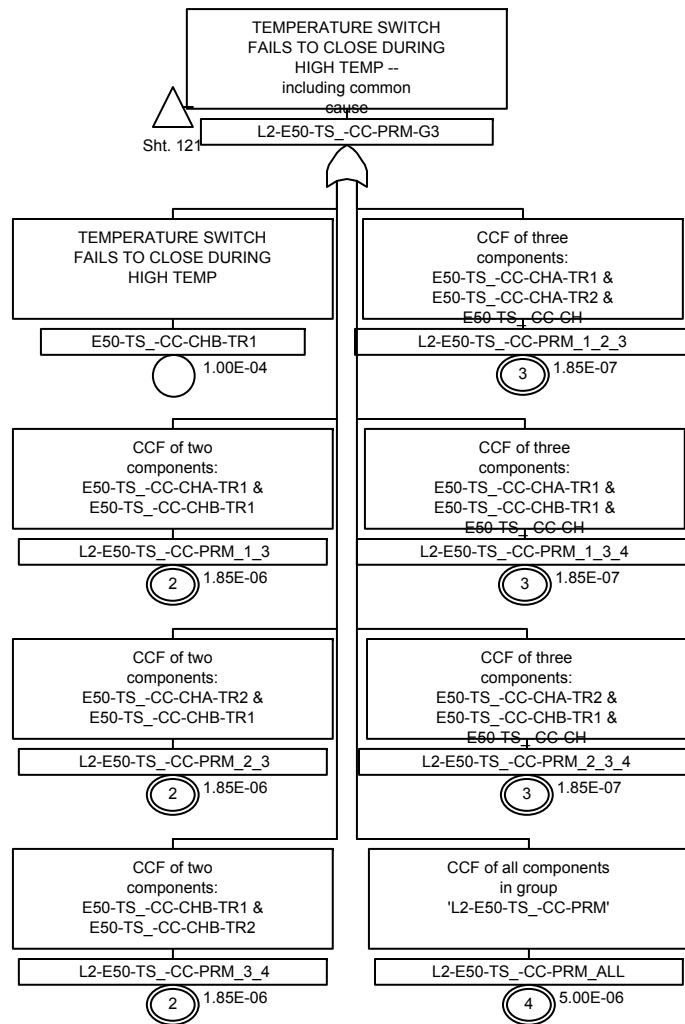

Figure 8A-8. Level 2 Fault Trees
Sheet 122 of 147

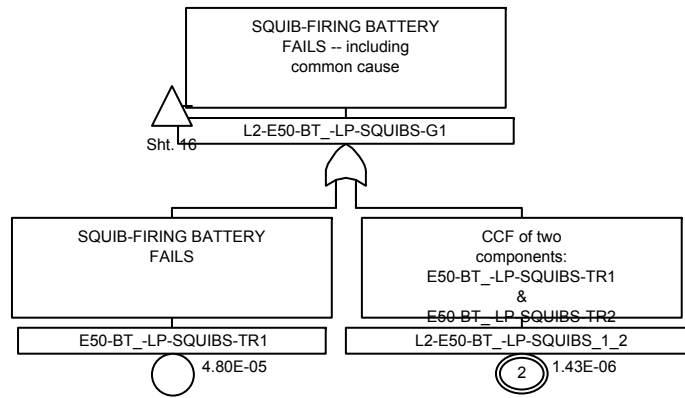

Figure 8A-8. Level 2 Fault Trees
Sheet 123 of 147

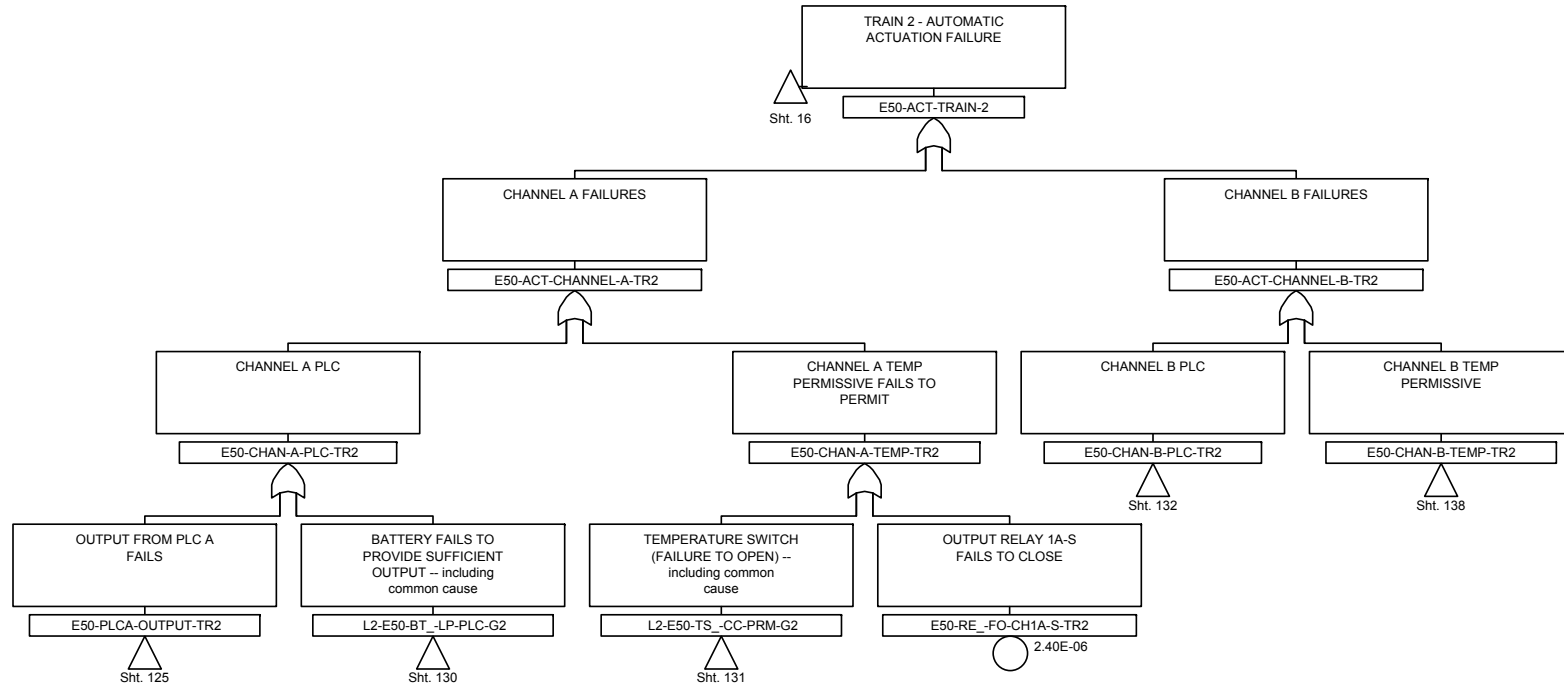

Figure 8A-8. Level 2 Fault Trees
Sheet 124 of 147

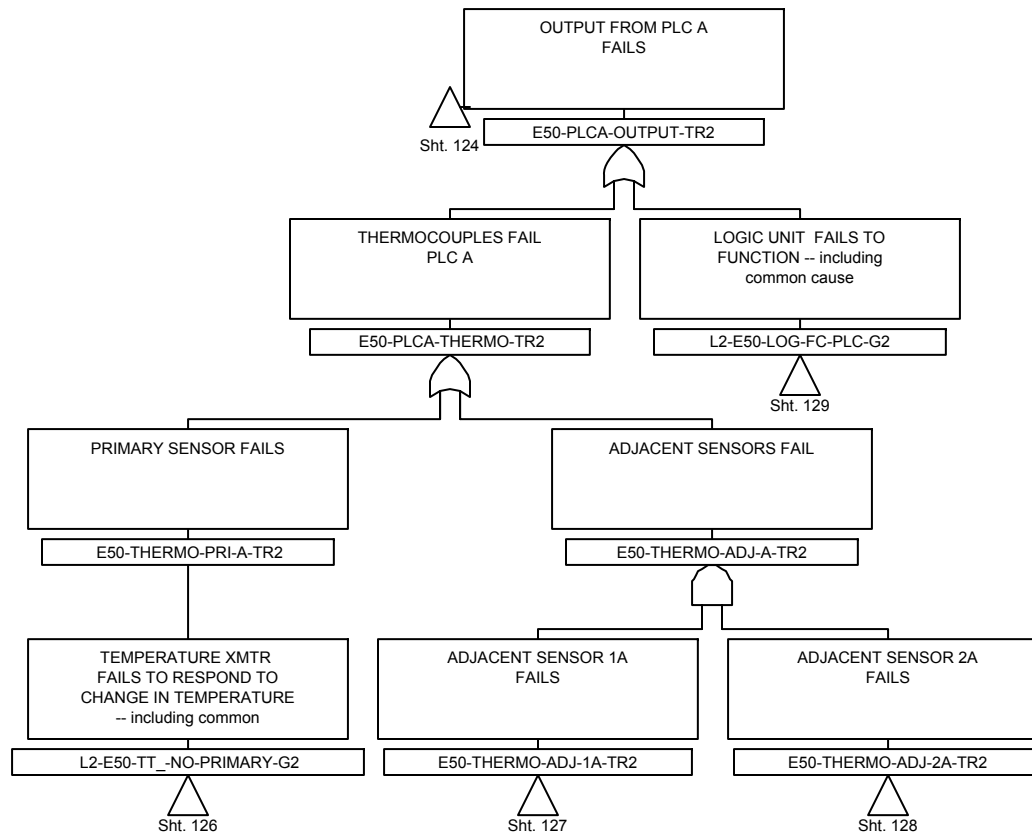

Figure 8A-8. Level 2 Fault Trees
Sheet 125 of 147

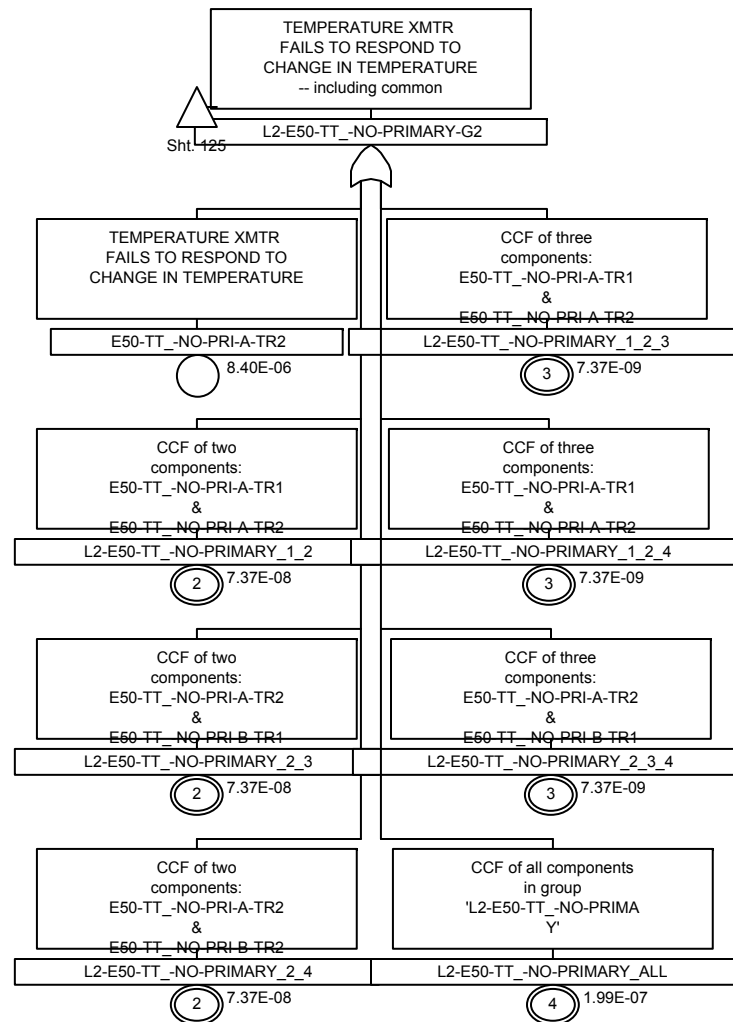

Figure 8A-8. Level 2 Fault Trees
Sheet 126 of 147

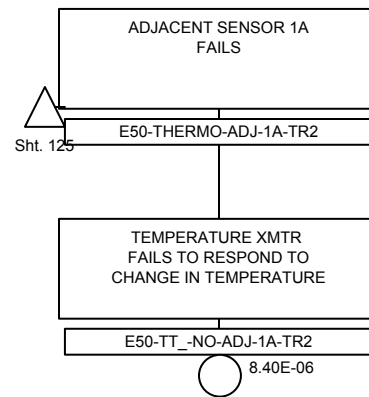

Figure 8A-8. Level 2 Fault Trees
Sheet 127 of 147

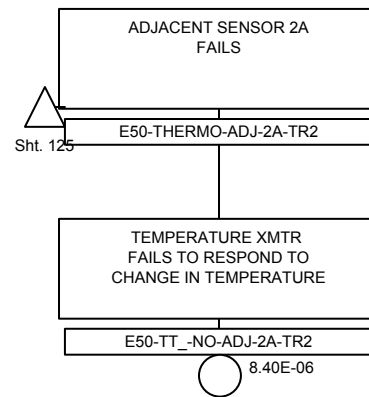

Figure 8A-8. Level 2 Fault Trees
Sheet 128 of 147

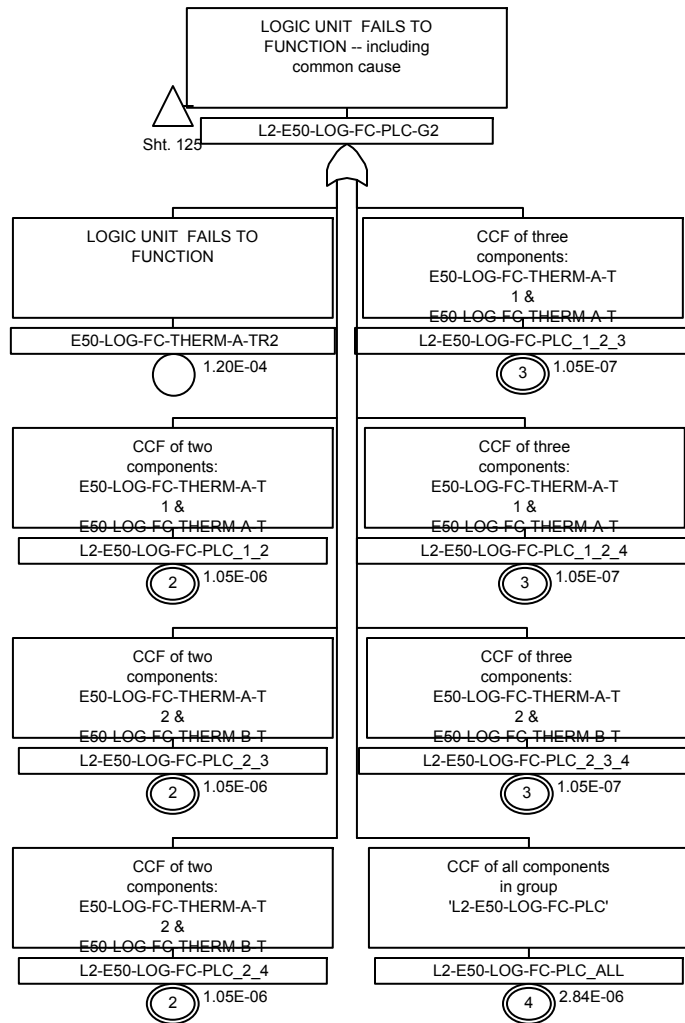

Figure 8A-8. Level 2 Fault Trees
Sheet 129 of 147

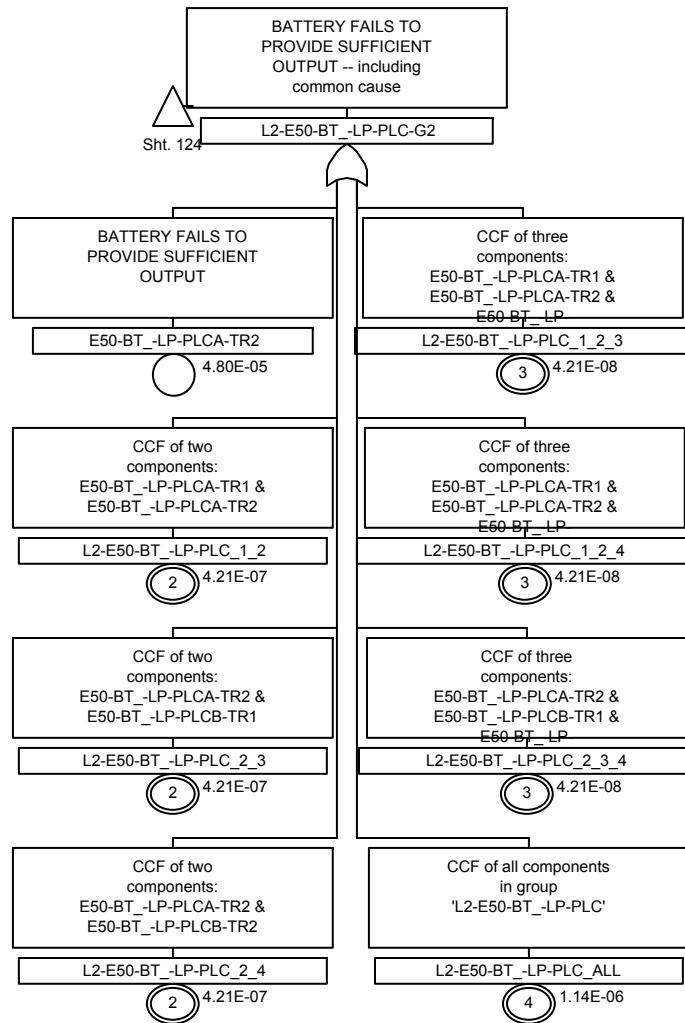

Figure 8A-8. Level 2 Fault Trees
Sheet 130 of 147

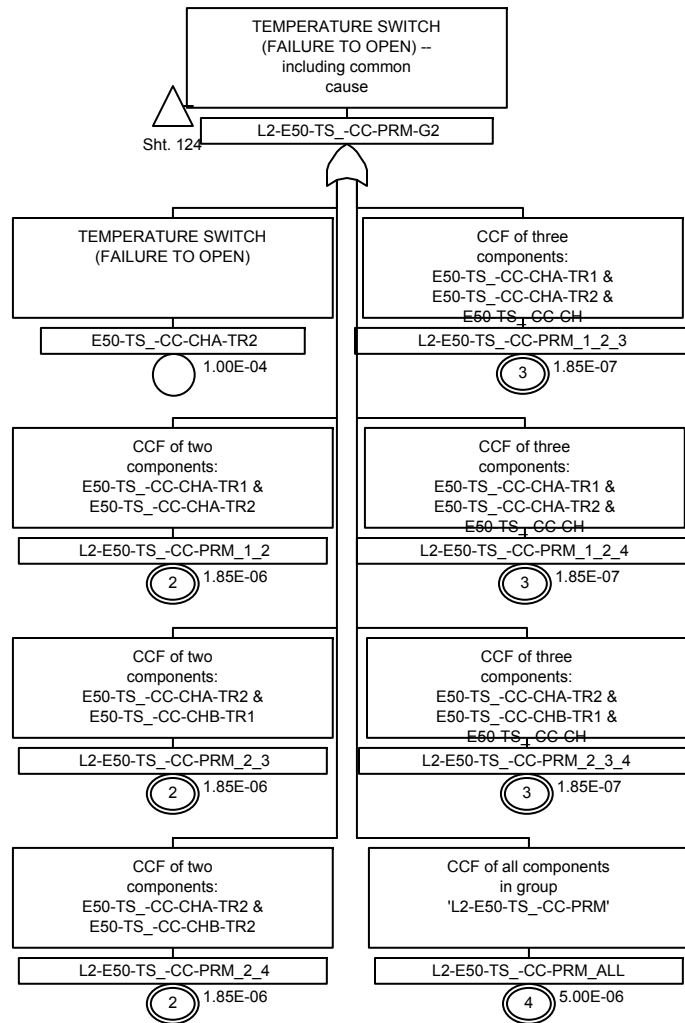

Figure 8A-8. Level 2 Fault Trees
Sheet 131 of 147

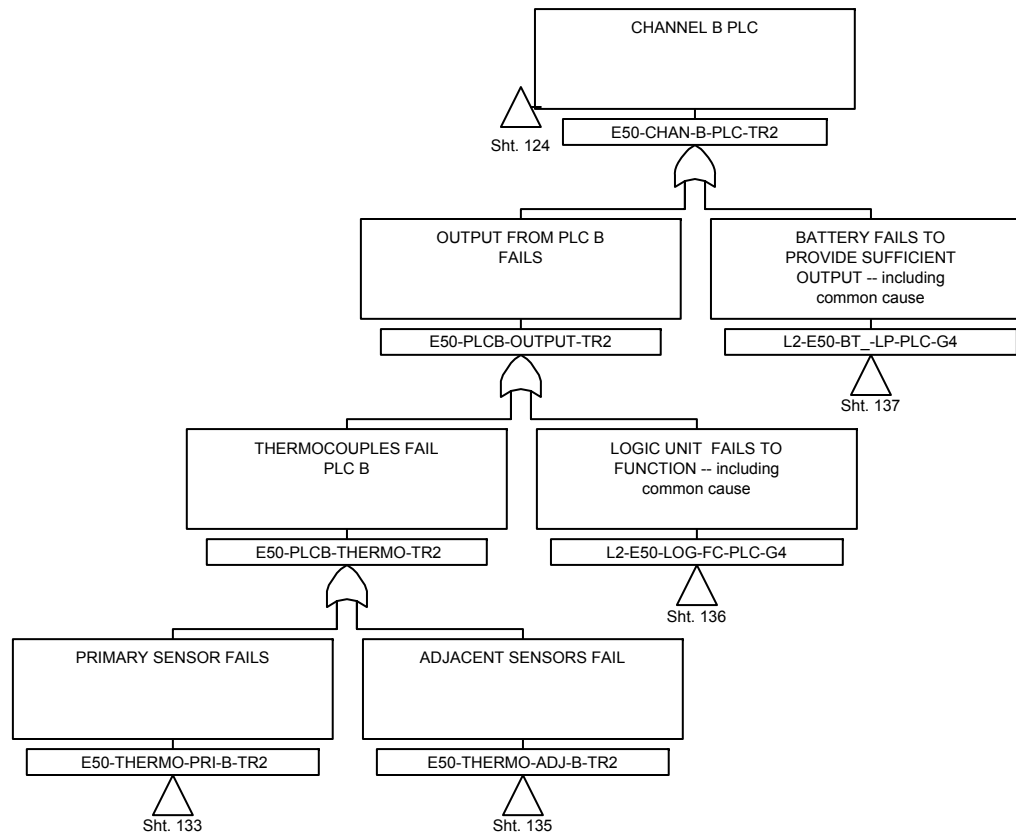

Figure 8A-8. Level 2 Fault Trees
Sheet 132 of 147

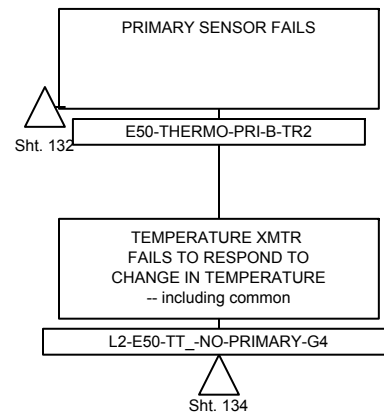

Figure 8A-8. Level 2 Fault Trees
Sheet 133 of 147

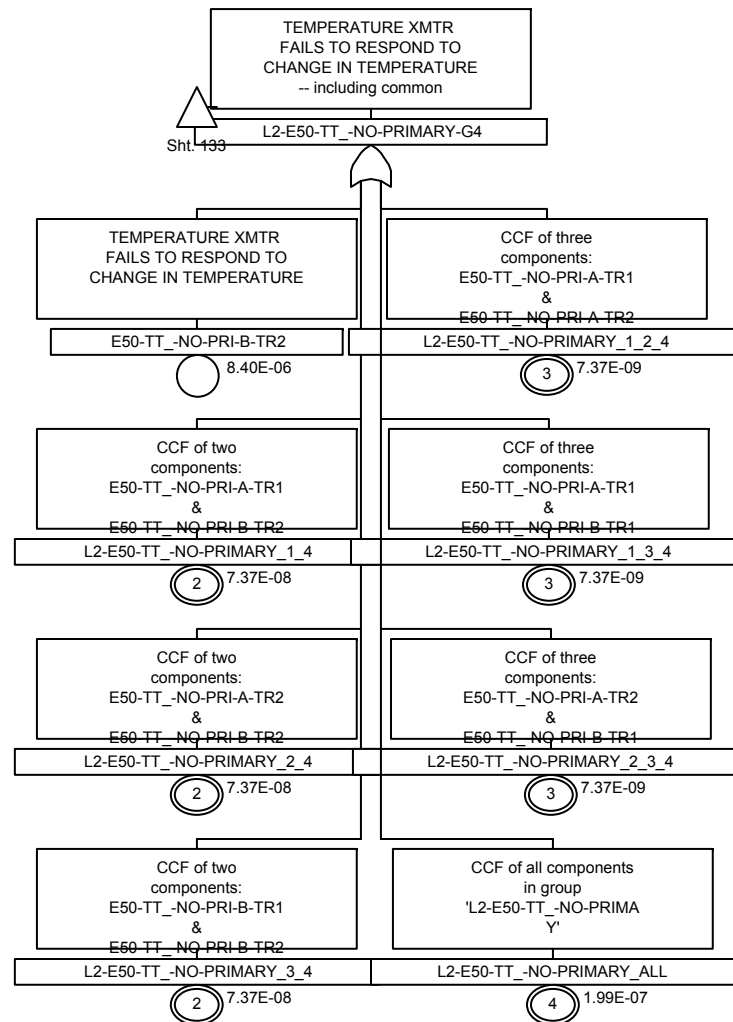

Figure 8A-8. Level 2 Fault Trees
Sheet 134 of 147

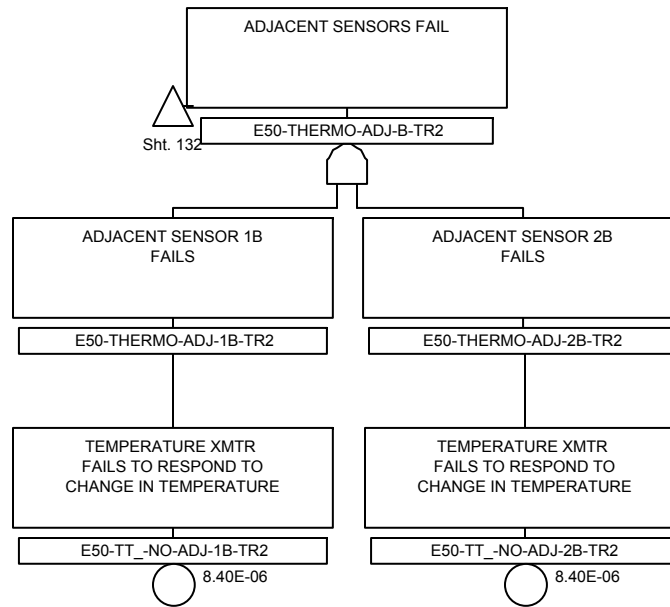

Figure 8A-8. Level 2 Fault Trees
Sheet 135 of 147

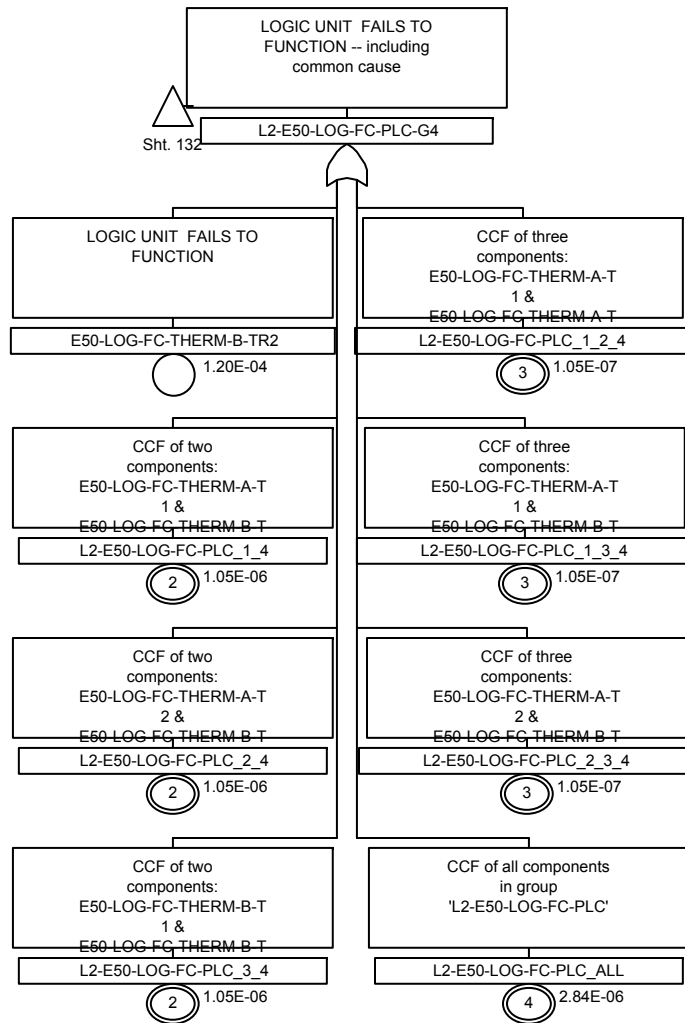

Figure 8A-8. Level 2 Fault Trees
Sheet 136 of 147

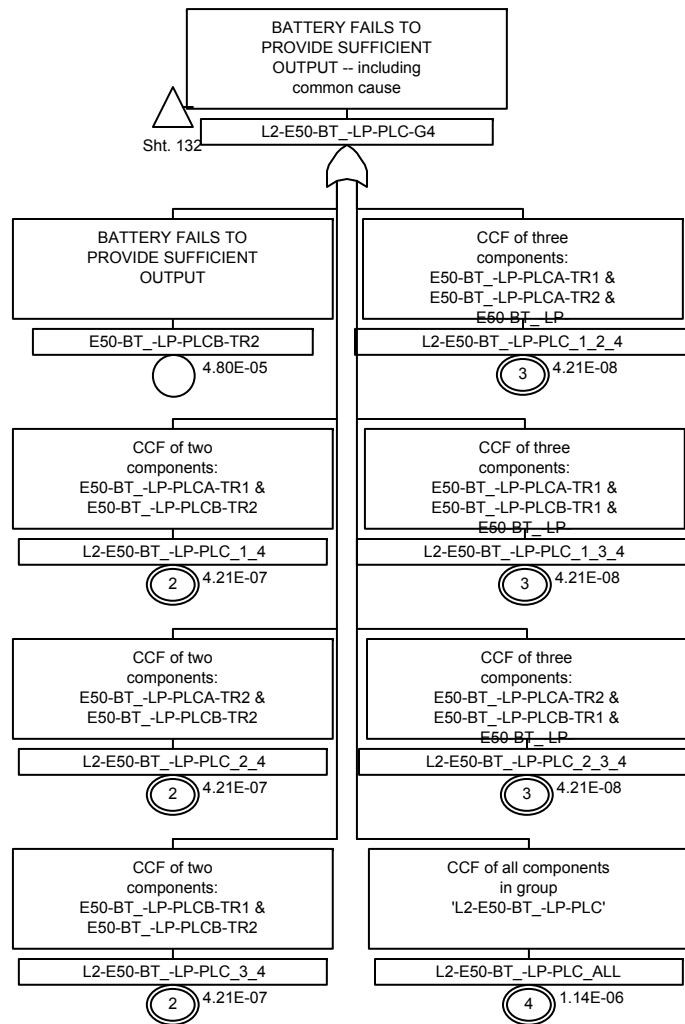

Figure 8A-8. Level 2 Fault Trees
Sheet 137 of 147

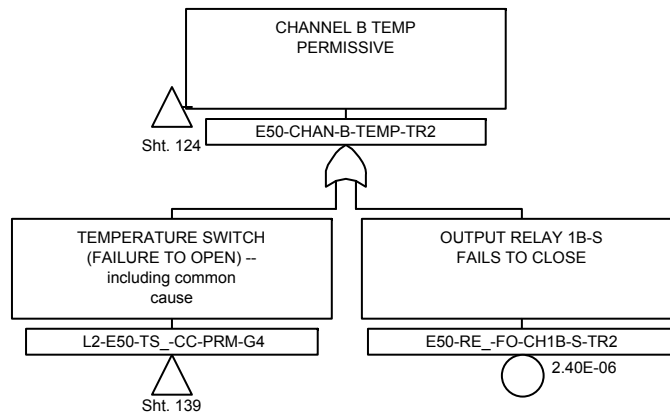

Figure 8A-8. Level 2 Fault Trees
Sheet 138 of 147

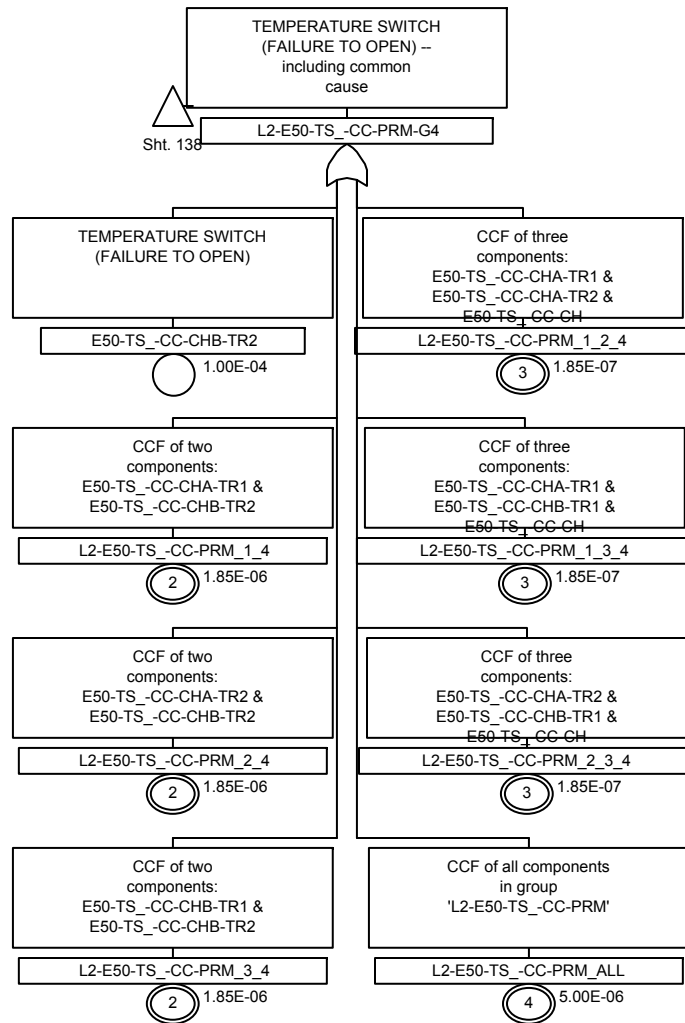

Figure 8A-8. Level 2 Fault Trees
Sheet 139 of 147

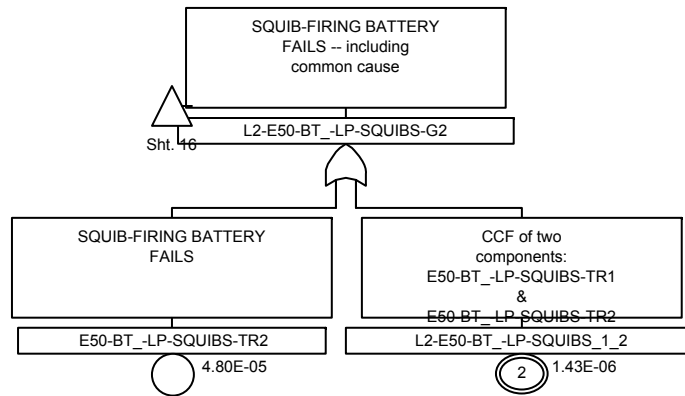

Figure 8A-8. Level 2 Fault Trees
Sheet 140 of 147

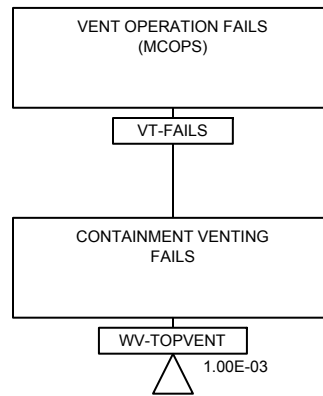

Figure 8A-8. Level 2 Fault Trees
Sheet 141 of 147

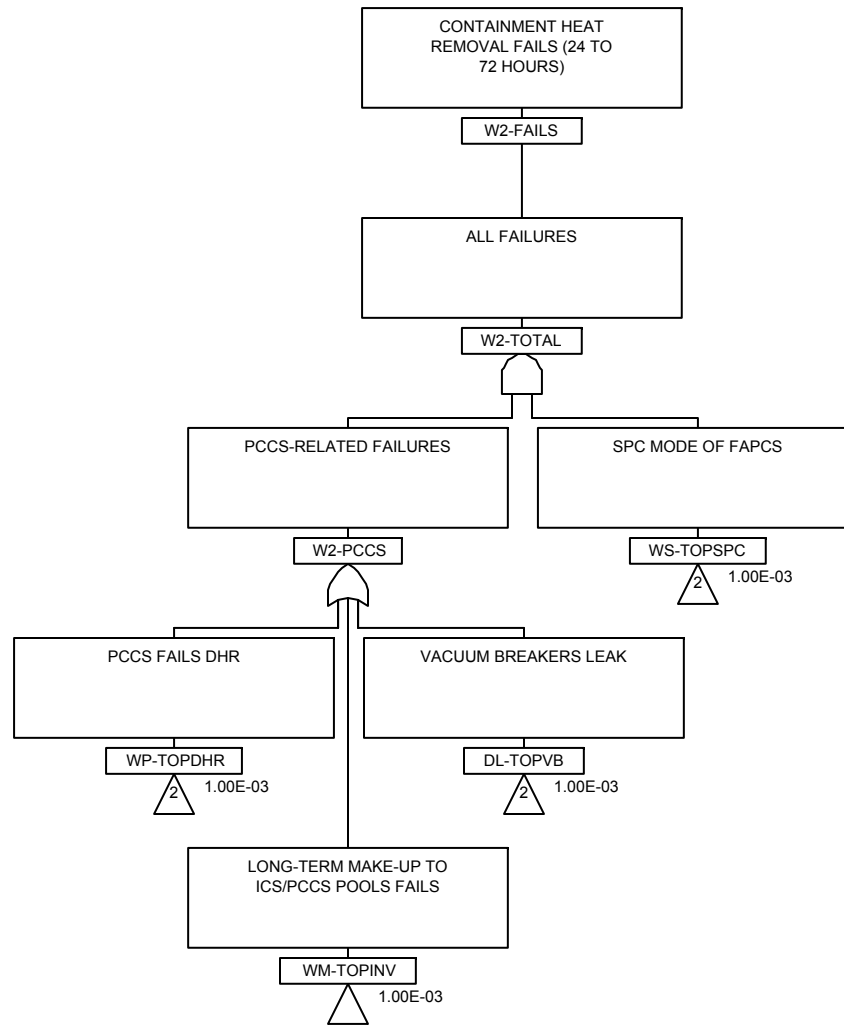

Figure 8A-8. Level 2 Fault Trees
Sheet 142 of 147

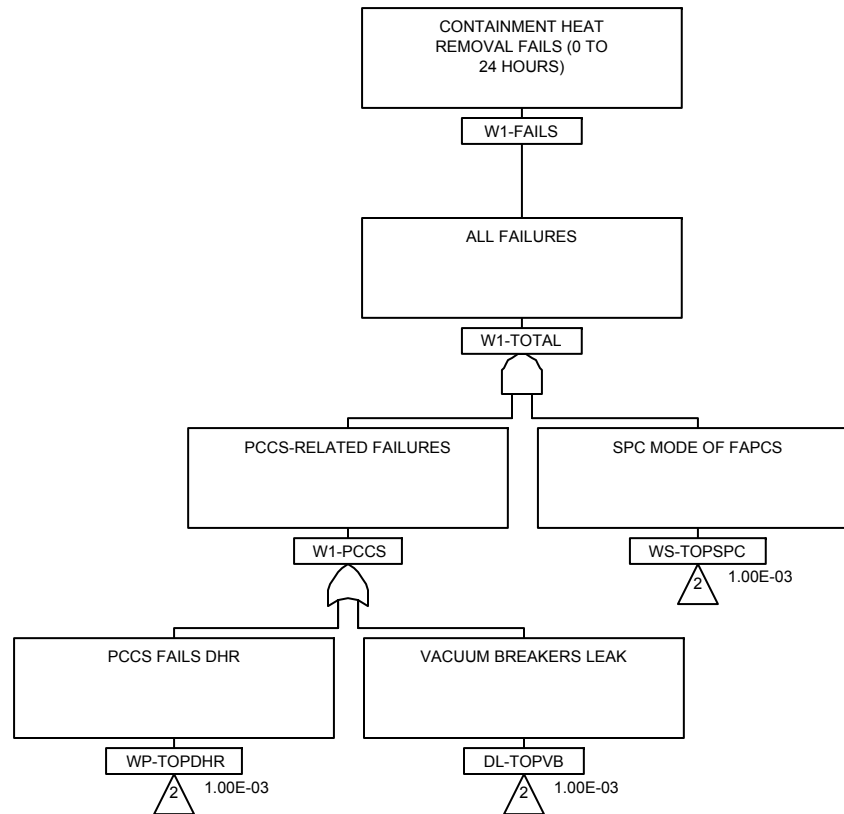

Figure 8A-8. Level 2 Fault Trees
Sheet 143 of 147

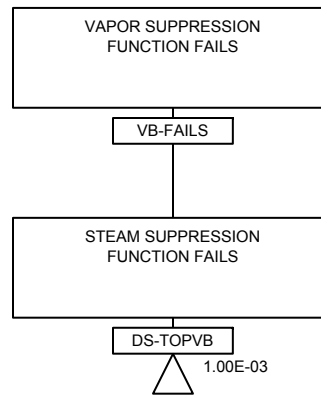

Figure 8A-8. Level 2 Fault Trees
Sheet 144 of 147

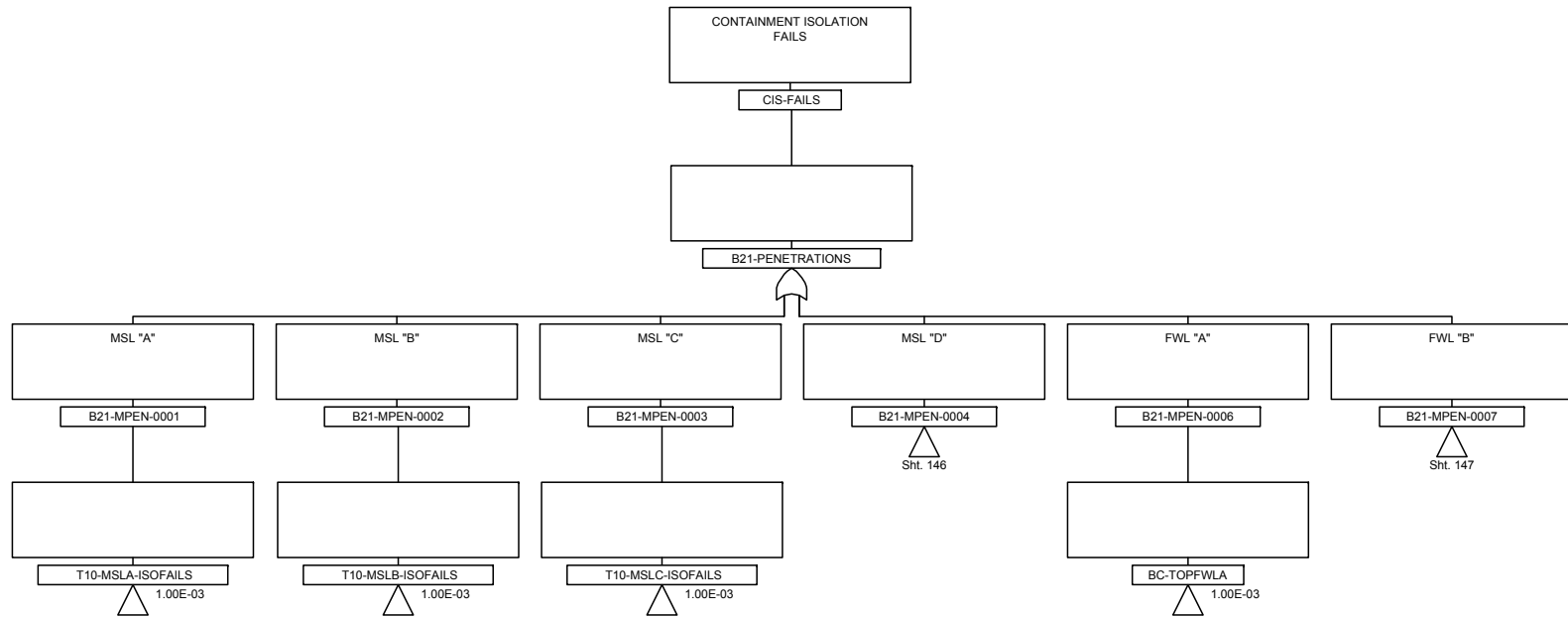

Figure 8A-8. Level 2 Fault Trees
Sheet 145 of 147

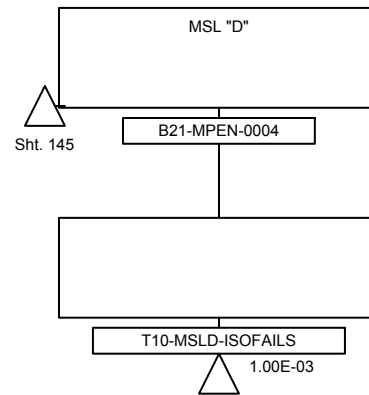

Figure 8A-8. Level 2 Fault Trees
Sheet 146 of 147

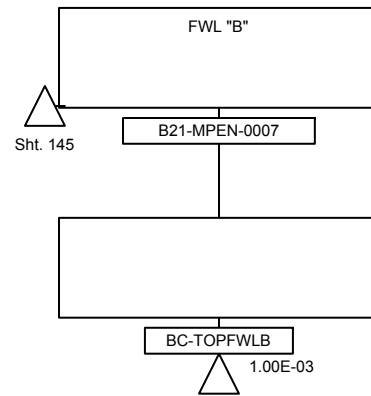

Figure 8A-8. Level 2 Fault Trees
Sheet 147 of 147