

**UNITED STATES NUCLEAR REGULATORY COMMISSION  
BOILING WATER REACTOR GENERIC FUNDAMENTALS EXAMINATION  
JUNE 2008 --FORM A**

**Please Print**

Name: \_\_\_\_\_

Docket No.: \_\_\_\_\_

Facility: \_\_\_\_\_

Start Time: \_\_\_\_\_ Stop Time: \_\_\_\_\_

**INSTRUCTIONS TO APPLICANT**

Answer all the test items using the answer sheet provided, ensuring a single answer is marked for each test item. Each test item has equal point value. A score of at least 80% is required to pass this portion of the NRC operator licensing written examination. All examination papers will be collected 3.0 hours after the examination begins. This examination applies to a typical boiling water reactor (BWR) nuclear power plant.

SECTION	QUESTIONS	% OF TOTAL	SCORE
COMPONENTS	1 - 22		
REACTOR THEORY	23 - 36		
THERMODYNAMICS	37 - 50		
TOTALS	50		

All work performed on this examination is my own. I have neither given nor received aid.

\_\_\_\_\_  
Applicant's Signature

**RULES AND GUIDELINES FOR THE NRC  
GENERIC FUNDAMENTALS EXAMINATION**

During the administration of this examination the following rules apply:

NOTE: The generic term "control rod" refers to the length of neutron absorber material that can be positioned by the operator to change core reactivity.

1. Print your name in the blank provided on the cover sheet of the examination.
2. Fill in your individual docket number.
3. Fill in the name of your facility.
4. Fill in your start and stop times at the appropriate time.
5. Two aids are provided for your use during the examination:
  - (1) An equations and conversions sheet contained within the examination copy, and
  - (2) Steam tables and Mollier Diagram provided by your proctor.
6. Place your answers on the answer sheet provided. Credit will only be given for answers properly marked on this sheet. Follow the instructions for filling out the answer sheet.
7. Scrap paper will be provided for calculations.
8. Cheating on the examination will result in the automatic forfeiture of this examination. Cheating could also result in severe penalties.
9. Restroom trips are limited. Only **ONE** examinee may leave the room at a time. In order to avoid the appearance or possibility of cheating, avoid all contact with anyone outside of the examination room.
10. After you have completed the examination, sign the statement on the cover sheet indicating that the work is your own and you have neither given nor received any assistance in completing the examination. Either pencil or pen may be used.
11. Turn in your examination materials, answer sheet on top, followed by the examination copy and the examination aids - steam table booklets, handouts, and scrap paper used during the examination.
12. After turning in your examination materials, leave the examination area, as defined by the proctor. If after leaving you are found in the examination area while the examination is in progress, your examination may be forfeited.

**GENERIC FUNDAMENTALS EXAMINATION**  
**EQUATIONS AND CONVERSIONS HANDOUT SHEET**

**EQUATIONS**

---

$$\dot{Q} = \dot{m}c_p\Delta T$$

$$\dot{Q} = \dot{m}\Delta h$$

$$\dot{Q} = UA\Delta T$$

$$\dot{Q} \propto \dot{m}_{\text{Nat Circ}}^3$$

$$\Delta T \propto \dot{m}_{\text{Nat Circ}}^2$$

$$K_{\text{eff}} = 1/(1 - \rho)$$

$$\rho = (K_{\text{eff}} - 1)/K_{\text{eff}}$$

$$\text{SUR} = 26.06/\tau$$

$$\tau = \frac{\bar{\beta}_{\text{eff}} - \rho}{\lambda_{\text{eff}} \rho}$$

$$\rho = \frac{\ell^*}{\tau} + \frac{\bar{\beta}_{\text{eff}}}{1 + \lambda_{\text{eff}} \tau}$$

$$\ell^* = 1 \times 10^{-4} \text{ sec}$$

$$\lambda_{\text{eff}} = 0.1 \text{ sec}^{-1} \text{ (for small positive } \rho)$$

$$\text{DRW} \propto \phi_{\text{tip}}^2 / \phi_{\text{avg}}^2$$

$$P = P_o 10^{\text{SUR}(t)}$$

$$P = P_o e^{(t/\tau)}$$

$$A = A_o e^{-\lambda t}$$

$$\text{CR}_{\text{S/D}} = S/(1 - K_{\text{eff}})$$

$$\text{CR}_1(1 - K_{\text{eff}1}) = \text{CR}_2(1 - K_{\text{eff}2})$$

$$1/M = \text{CR}_1/\text{CR}_x$$

$$A = \pi r^2$$

$$F = PA$$

$$\dot{m} = \rho A \bar{v}$$

$$\dot{W}_{\text{pump}} = \dot{m}\Delta P v$$

$$E = IR$$

Thermal Efficiency = Net Work Out/Energy In

$$\frac{g(z_2 - z_1)}{g_c} + \frac{(\bar{v}_2^2 - \bar{v}_1^2)}{2g_c} + v(P_2 - P_1) + (u_2 - u_1) + (q - w) = 0$$

$$g_c = 32.2 \text{ lbm-ft/lbf-sec}^2$$

**CONVERSIONS**

---

$$1 \text{ Mw} = 3.41 \times 10^6 \text{ Btu/hr}$$

$$1 \text{ hp} = 2.54 \times 10^3 \text{ Btu/hr}$$

$$1 \text{ Btu} = 778 \text{ ft-lbf}$$

$$^\circ\text{C} = (5/9)(^\circ\text{F} - 32)$$

$$^\circ\text{F} = (9/5)(^\circ\text{C}) + 32$$

$$1 \text{ Curie} = 3.7 \times 10^{10} \text{ dps}$$

$$1 \text{ kg} = 2.21 \text{ lbm}$$

$$1 \text{ gal}_{\text{water}} = 8.35 \text{ lbm}$$

$$1 \text{ ft}^3_{\text{water}} = 7.48 \text{ gal}$$

**USNRC GENERIC FUNDAMENTALS EXAMINATION  
JUNE 2008 BWR--FORM A**

QUESTION: 1

Vessels A and B are identical except that vessel A receives overpressure protection from an installed safety valve. Vessel B has an installed relief valve. The safety and relief valves have the same pressure setpoint and design flow rate.

Water is continuously added to each vessel at the same rate (50% of the design flow rate of the safety and relief valves). After vessel pressure reaches the setpoint for each valve, vessel A pressure will \_\_\_\_\_ and vessel B pressure will \_\_\_\_\_.

- A. stabilize slightly above the pressure setpoint; stabilize slightly above the pressure setpoint
- B. stabilize slightly above the pressure setpoint; fluctuate within a few percent of the pressure setpoint
- C. fluctuate within a few percent of the pressure setpoint; stabilize slightly above the pressure setpoint
- D. fluctuate within a few percent of the pressure setpoint; fluctuate within a few percent of the pressure setpoint

QUESTION: 2

Which one of the following is a generally accepted method for locally verifying that a manual valve is fully closed in a depressurized static piping system?

- A. Check a downstream flow gauge to be indicating zero flow.
- B. Compare an upstream and downstream pressure gauge to ensure zero differential pressure.
- C. Attempt to turn the valve handwheel in the close direction and verify no movement.
- D. Attempt to turn the valve handwheel in the open direction and verify movement.

**USNRC GENERIC FUNDAMENTALS EXAMINATION  
JUNE 2008 BWR--FORM A**

QUESTION: 3

In a comparison between ball valves and butterfly valves in the same liquid process system application, the valves that typically are more leak-tight when fully closed and under high differential pressure are \_\_\_\_\_ valves; and the valves that typically result in the higher system pressure drop when fully open are \_\_\_\_\_ valves.

- A. ball; butterfly
- B. ball; ball
- C. butterfly; butterfly
- D. butterfly; ball

**USNRC GENERIC FUNDAMENTALS EXAMINATION  
JUNE 2008 BWR--FORM A**

QUESTION: 4

Refer to the drawing in which subcooled water is flowing through a convergent-divergent venturi (see figure below). The pipe diameters at P1 and P2 are equal.

Compared to the conditions at the inlet of the venturi (P1), the pressure at the outlet of the venturi (P2) has \_\_\_\_\_ and water velocity at the outlet of the venturi has \_\_\_\_\_. (Assume "real" conditions.)

- A. remained the same; remained the same
- B. remained the same; decreased slightly
- C. decreased slightly; remained the same
- D. decreased slightly; decreased slightly

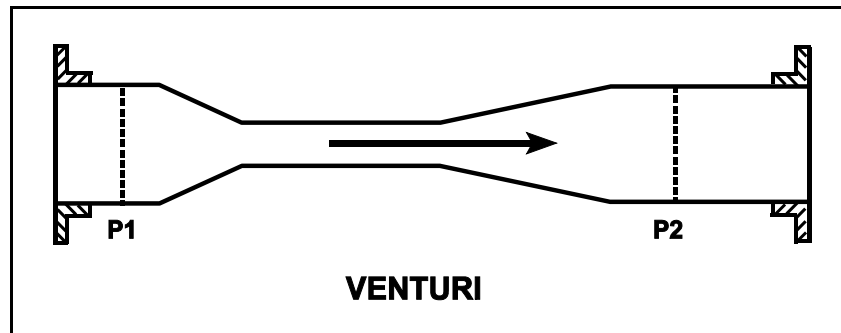

**USNRC GENERIC FUNDAMENTALS EXAMINATION  
JUNE 2008 BWR--FORM A**

QUESTION: 5

Refer to the drawing of a reactor vessel differential pressure (D/P) level detection system (see figure below).

Which one of the following events will result in a reactor vessel level indication that is greater than actual level?

- A. The external pressure surrounding the D/P detector decreases by 2 psi.
- B. Reactor vessel pressure increases by 10 psi with no change in actual water level.
- C. Actual vessel level increases by 6 inches.
- D. The temperature of the reference leg increases by 20°F.

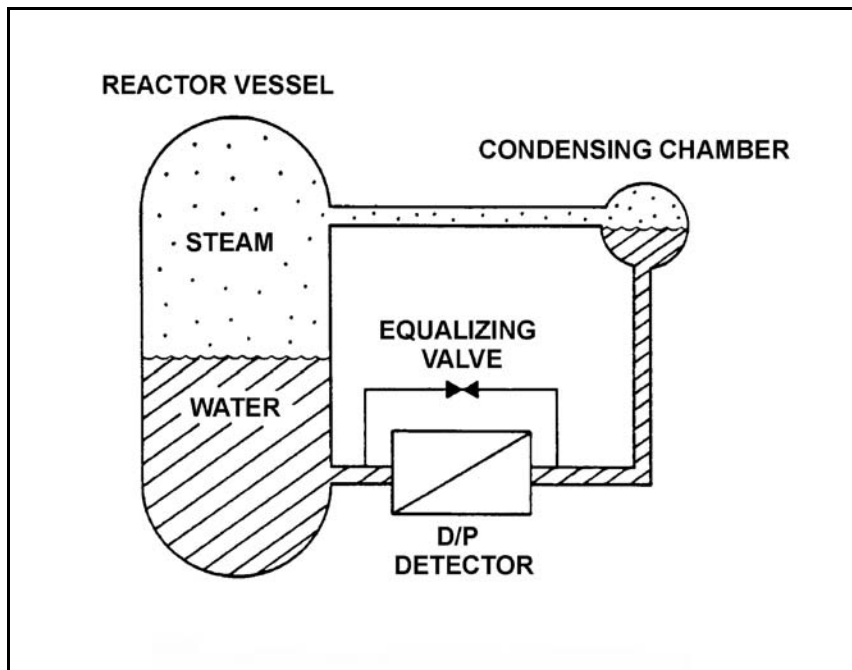

**USNRC GENERIC FUNDAMENTALS EXAMINATION  
JUNE 2008 BWR--FORM A**

QUESTION: 6

Which one of the following devices is commonly used to provide remote indication of valve position on an analog meter in units of "percent of full open"?

- A. Limit switch
- B. Reed switch
- C. Linear variable differential transformer
- D. Resistance temperature detector

QUESTION: 7

A proportional detector with pulse height discrimination circuitry is being used in a constant field of neutron and gamma radiation to provide source range neutron count rate indication. Assume that the pulse height discrimination setpoint does not change.

If the detector's operating voltage is increased but maintained within the true proportional operating region, count rate indication will increase because...

- A. a single neutron- or gamma- induced ionizing event will result in multiple pulses inside the detector.
- B. the ratio of the number of neutron-induced pulses to gamma-induced pulses inside the detector will increase.
- C. the positive space charge effect will increase and promote the collection of both gamma- and neutron-induced pulses.
- D. all detector pulses will increase in amplitude and previously uncounted gamma pulses will be added to the total count rate.



**USNRC GENERIC FUNDAMENTALS EXAMINATION  
JUNE 2008 BWR--FORM A**

QUESTION: 8

Consider a direct-acting proportional flow controller that is maintaining flow rate at a value that is offset from the controller setpoint. If the controller's gain is increased, the controller's offset will \_\_\_\_\_ and the controller's proportional band will \_\_\_\_\_.

- A. decrease; decrease
- B. decrease; increase
- C. increase; decrease
- D. increase; increase

**USNRC GENERIC FUNDAMENTALS EXAMINATION  
JUNE 2008 BWR--FORM A**

QUESTION: 9

The temperature of the water in a storage tank is monitored by a bistable alarm circuit. If water temperature decreases to 50°F a bistable turns on to actuate an alarm indicator. As soon as the water temperature exceeds 50°F the bistable turns off to clear the alarm.

Which one of the following bistable symbols indicates the characteristics of the bistable used in the alarm circuit?

- A. 1.
- B. 2.
- C. 3.
- D. 4.

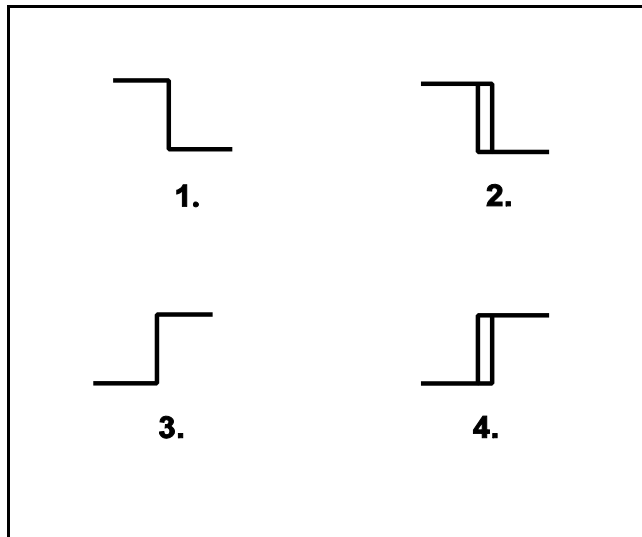

**USNRC GENERIC FUNDAMENTALS EXAMINATION  
JUNE 2008 BWR--FORM A**

QUESTION: 10

A centrifugal pump is taking suction on a water storage tank and delivering the makeup water to a cooling water system. The pump will have the lowest net positive suction head requirement if the pump is operated at a relatively \_\_\_\_\_ speed with a \_\_\_\_\_ discharge flow control valve.

- A. high; fully open
- B. high; throttled
- C. low; fully open
- D. low; throttled

QUESTION: 11

When a centrifugal pump is operating at shutoff head, it is pumping at \_\_\_\_\_ capacity and \_\_\_\_\_ discharge head.

- A. maximum; maximum
- B. maximum; minimum
- C. minimum; maximum
- D. minimum; minimum

**USNRC GENERIC FUNDAMENTALS EXAMINATION  
JUNE 2008 BWR--FORM A**

QUESTION: 12

Refer to the drawing of a cooling water system in which only centrifugal pump A is operating and the common pump discharge valve is currently 90% open (see figure below).

An abnormal total heat load on the cooling water system is causing pump A to approach operation at runout conditions. Which one of the following will cause pump A to operate farther away from runout conditions? (Assume that satisfactory available net positive suction head is maintained at all times.)

- A. Starting pump B.
- B. Positioning the discharge valve to 100% open.
- C. Raising the water level in the surge tank by 2 feet.
- D. Decreasing heat exchanger service water flow rate by 10%.

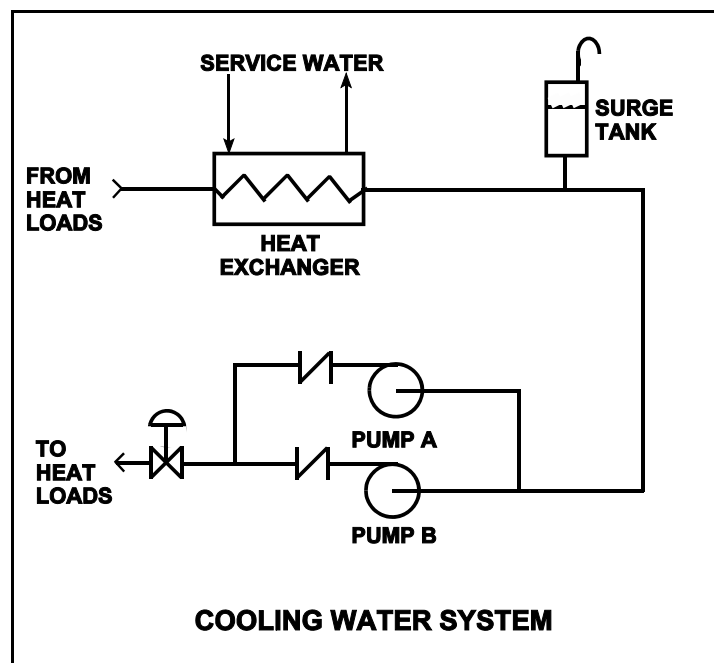

**USNRC GENERIC FUNDAMENTALS EXAMINATION  
JUNE 2008 BWR--FORM A**

QUESTION: 13

Prior to starting a positive displacement pump, the discharge valve should be open to...

- A. prevent rupturing the pump casing.
- B. limit the pump motor starting time.
- C. ensure the pump casing fills by backflow.
- D. reduce pressure fluctuations in the discharge piping.

QUESTION: 14

Which one of the following will provide the initial motor protection against electrical damage caused by gradual bearing failure?

- A. Thermal overload device
- B. Overcurrent trip relay
- C. Underfrequency relay
- D. Undervoltage device

**USNRC GENERIC FUNDAMENTALS EXAMINATION  
JUNE 2008 BWR--FORM A**

QUESTION: 15

A multi-speed motor-driven centrifugal pump is operating with the following parameters:

Motor current = 27 amps  
Pump head = 50 psi  
Pump flow rate = 880 gpm

Which one of the following will be the approximate new value of pump head if pump speed is increased such that the motor current is now 64 amps?

- A. 89 psi
- B. 119 psi
- C. 211 psi
- D. 281 psi

**USNRC GENERIC FUNDAMENTALS EXAMINATION  
JUNE 2008 BWR--FORM A**

QUESTION: 16

Refer to the drawing of an operating water cleanup system (see figure below). Valves A, B, and D are fully open and valve C is 50% open.

If valve C is opened to 100%, how will the temperatures at points 3 and 6 be affected?

- | <u>Point 3</u> | <u>Point 6</u> |
|----------------|----------------|
| A. Decrease    | Decrease       |
| B. Decrease    | Increase       |
| C. Increase    | Decrease       |
| D. Increase    | Increase       |

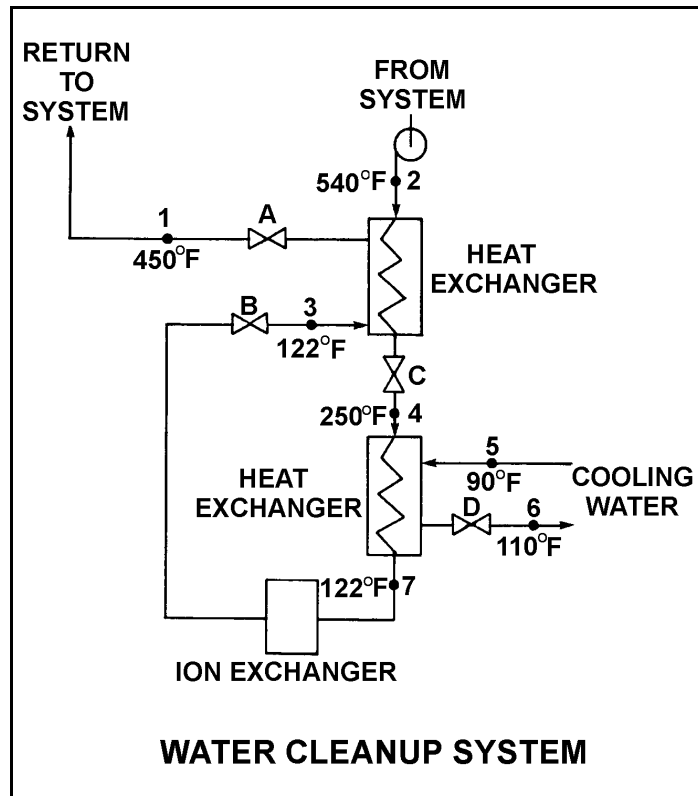

**USNRC GENERIC FUNDAMENTALS EXAMINATION  
JUNE 2008 BWR--FORM A**

QUESTION: 17

Refer to the drawing of an operating lube oil heat exchanger (see figure below).

Assume that the inlet lube oil and inlet cooling water temperatures are constant and the lube oil flow rate remains the same. If the cooling water flow rate increases, the lube oil outlet temperature will \_\_\_\_\_ and the cooling water outlet temperature will \_\_\_\_\_.

- A. increase, increase
- B. increase, decrease
- C. decrease, increase
- D. decrease, decrease

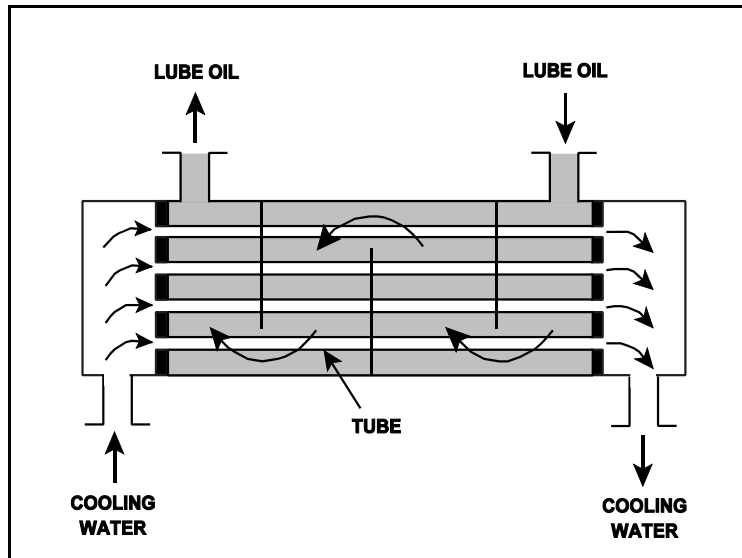



**USNRC GENERIC FUNDAMENTALS EXAMINATION  
JUNE 2008 BWR--FORM A**

QUESTION: 18

Refer to the drawing of an operating cooling water system (see figure below).

Which one of the following will occur as a result of the indicated tube failure in the heat exchanger?

- A. High pressure (HP) fluid inventory increases.
- B. Pressure in the low pressure (LP) system decreases.
- C. Temperature in the low pressure (LP) system increases.
- D. Level in the surge tank decreases.

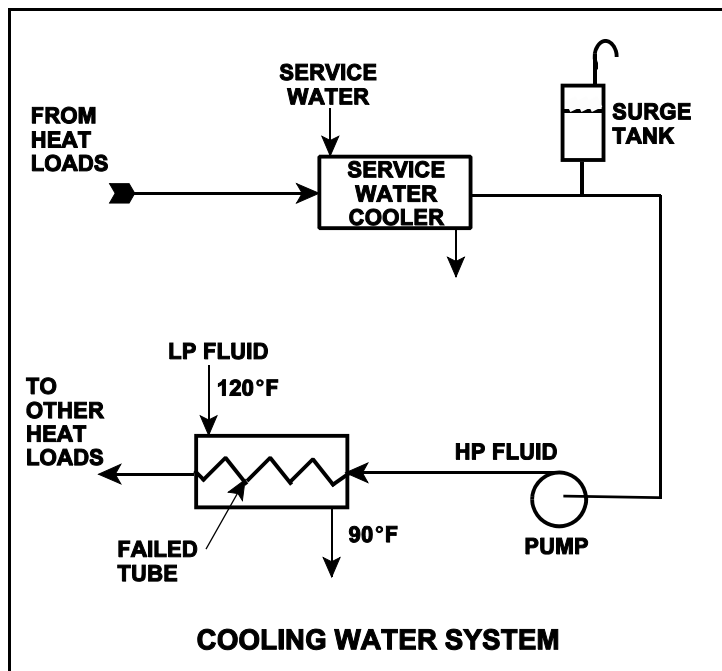

**USNRC GENERIC FUNDAMENTALS EXAMINATION  
JUNE 2008 BWR--FORM A**

QUESTION: 19

A condensate demineralizer differential pressure (D/P) gauge indicates 9.0 psid at 50% flow. Over the next two days, plant power changes cause condensate flow to vary between 10% and 100%.

Which one of the following combinations of condensate flow and demineralizer D/P, if observed during the power changes, would indicate a detectable increase in the accumulation of corrosion products in the demineralizer?

	<u>Condensate Flow Rate</u>	<u>Demineralizer D/P (psid)</u>
A.	10%	0.3
B.	25%	3.3
C.	75%	20.3
D.	100%	35.3

QUESTION: 20

A result of proper demineralizer operation on water with ionic impurities is that the exiting water will always have a...

- A. higher pH.
- B. lower pH.
- C. higher conductivity.
- D. lower conductivity.

**USNRC GENERIC FUNDAMENTALS EXAMINATION  
JUNE 2008 BWR--FORM A**

QUESTION: 21

A main generator is being connected to an infinite power grid. The following frequencies exist just prior to closing the generator output breaker:

Generator frequency: 59.9 Hz  
Grid frequency: 60.1 Hz

When conditions stabilize just after the generator output breaker is closed, the generator frequency will be \_\_\_\_\_ and the grid frequency will be \_\_\_\_\_.

- A. 59.9 Hz; 59.9 Hz
- B. 59.9 Hz; 60.1 Hz
- C. 60.0 Hz; 60.0 Hz
- D. 60.1 Hz; 60.1 Hz

QUESTION: 22

A 480 Vac motor control center supplies a load through a breaker and a manual disconnect. If both isolation devices are operated to isolate the load, which one of the following sequences will provide the greatest level of personnel safety when deenergizing the load for maintenance and when reenergizing the load after the maintenance?

DEENERGIZING      REENERGIZING

- A. Open breaker first      Shut breaker first
- B. Open breaker first      Shut disconnect first
- C. Open disconnect first      Shut breaker first
- D. Open disconnect first      Shut disconnect first

**USNRC GENERIC FUNDAMENTALS EXAMINATION  
JUNE 2008 BWR--FORM A**

QUESTION: 23

Which one of the following conditions will increase the amount of neutron moderation in a nuclear reactor operating at 50% power?

- A. Increasing moderator temperature
- B. Reducing feedwater inlet temperature
- C. Reducing reactor vessel pressure
- D. Reducing reactor recirculation system flow rate

QUESTION: 24

With  $K_{\text{eff}} = 0.982$ , how much positive reactivity is required to make the reactor critical?

- A. 1.720%  $\Delta K/K$
- B. 1.767%  $\Delta K/K$
- C. 1.800%  $\Delta K/K$
- D. 1.833%  $\Delta K/K$

**USNRC GENERIC FUNDAMENTALS EXAMINATION  
JUNE 2008 BWR--FORM A**

QUESTION: 25

A reactor startup is in progress at a BWR nuclear power plant. The following stable conditions currently exist:

Reactor coolant temperature:	180°F
Control rod density:	50%
Source range count rate:	32 cps

Control rods are withdrawn to a control rod density of 45%, where the source range count rate stabilizes at 48 cps.

Assume that the control rod differential reactivity worth remains constant during the withdrawal. Also assume that reactor coolant temperature remains constant, and no reactor protection actuations occur.

If control rods are withdrawn further to a control rod density of 40%, what will be the status of the reactor?

- A. Subcritical, with a stable source range count rate of approximately 64 cps.
- B. Subcritical, with a stable source range count rate of approximately 96 cps.
- C. Critical, with a stable source range count rate of approximately 64 cps.
- D. Critical, with a stable source range count rate of approximately 96 cps.

**USNRC GENERIC FUNDAMENTALS EXAMINATION  
JUNE 2008 BWR--FORM A**

QUESTION: 26

Which one of the following isotopes is the most significant contributor to resonance capture of fission neutrons in a nuclear reactor core at the end of a fuel cycle?

- A. U-235
- B. U-238
- C. Pu-239
- D. Pu-240

QUESTION: 27

Which one of the following describes how and why the void coefficient of reactivity changes as void fraction increases during a control rod withdrawal at power?

- A. Becomes less negative due to the increased absorption of neutrons by U-238.
- B. Becomes less negative due to a greater fraction of neutrons lost to leakage from the core.
- C. Becomes more negative due to the reduction in the fast fission contribution to the neutron population.
- D. Becomes more negative due to a greater fractional loss of moderator for a 1% void increase at higher void fractions.

**USNRC GENERIC FUNDAMENTALS EXAMINATION  
JUNE 2008 BWR--FORM A**

QUESTION: 28

A nuclear reactor is exactly critical below the point of adding heat (POAH) during a normal reactor startup. If a control rod is manually withdrawn for 5 seconds, reactor power will...

- A. increase to a stable critical power level below the POAH.
- B. increase temporarily, then decrease and stabilize at the original value.
- C. increase to a stable critical power level at the POAH.
- D. increase temporarily, then decrease and stabilize below the original value.

QUESTION: 29

A nuclear reactor is operating at 60% power with thermal neutron flux peaked in the bottom half of the core. Partial withdrawal of a deep control rod will generally affect total (versus local) core power because \_\_\_\_\_ is relatively high in the area of withdrawal.

- A. fuel enrichment
- B. thermal neutron flux
- C. void content
- D. moderator temperature

**USNRC GENERIC FUNDAMENTALS EXAMINATION  
JUNE 2008 BWR--FORM A**

QUESTION: 30

Nuclear reactors A and B are operating at steady-state 100% power with equilibrium core Xe-135. The reactors are identical except that reactor A is operating at end of core life (EOL) and reactor B is operating at beginning of core life (BOL).

Which reactor has the smaller concentration of equilibrium core Xe-135?

- A. Reactor A (EOL) due to the smaller 100% power thermal neutron flux
- B. Reactor A (EOL) due to the larger 100% power thermal neutron flux
- C. Reactor B (BOL) due to the smaller 100% power thermal neutron flux
- D. Reactor B (BOL) due to the larger 100% power thermal neutron flux

QUESTION: 31

A nuclear reactor was shut down for seven days to perform maintenance. A reactor startup was performed, and power level was increased from 1% to 50% over a two hour period.

Ten hours after reactor power reaches 50%, the magnitude of core xenon-135 negative reactivity will be...

- A. increasing toward a downturn.
- B. increasing toward an equilibrium value.
- C. decreasing toward an equilibrium value.
- D. decreasing toward an upturn.



**USNRC GENERIC FUNDAMENTALS EXAMINATION  
JUNE 2008 BWR--FORM A**

QUESTION: 32

Refer to the drawing of  $K_{\text{eff}}$  versus core age for a nuclear reactor core following a refueling outage (see figure below).

Which one of the following is responsible for the majority of the decrease in  $K_{\text{eff}}$  from point 1 to point 2?

- A. Depletion of fuel
- B. Burnout of burnable poisons
- C. Initial heat-up of the reactor
- D. Buildup of fission product poisons

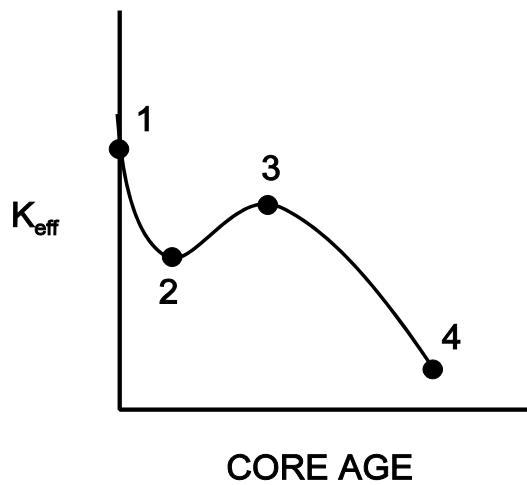

**USNRC GENERIC FUNDAMENTALS EXAMINATION  
JUNE 2008 BWR--FORM A**

QUESTION: 33

A nuclear power plant was operating at steady-state 100% power near the end of a fuel cycle when a reactor scram occurred. Reactor pressure is being maintained at 600 psig in anticipation of commencing a reactor startup.

Four hours after the scram, with reactor pressure still at 600 psig, which one of the following will cause the fission rate in the reactor core to increase?

- A. Reactor vessel pressure is allowed to increase by 20 psig.
- B. Reactor coolant temperature is allowed to increase by 3 °F.
- C. The operator fully withdraws the first group of control rods.
- D. An additional two hours is allowed to pass with no other changes in plant parameters.

QUESTION: 34

A nuclear reactor startup is in progress following a one-month shutdown. Upon reaching criticality, the operator establishes a positive 80-second period and stops control rod motion.

After an additional five minutes, reactor power will be \_\_\_\_\_ and reactor period will be \_\_\_\_\_. (Assume reactor power remains below the point of adding heat.)

- A. constant; constant
- B. constant; increasing
- C. increasing; constant
- D. increasing; increasing

**USNRC GENERIC FUNDAMENTALS EXAMINATION  
JUNE 2008 BWR--FORM A**

QUESTION: 35

Neglecting the effects of changes in core Xe-135, which one of the following power changes requires the greatest amount of positive reactivity addition?

- A. 3% power to 5% power
- B. 5% power to 15% power
- C. 15% power to 30% power
- D. 30% power to 60% power

QUESTION: 36

A nuclear power plant is initially operating at steady-state 60% power when a main steamline break develops that continuously releases 5% of rated main steam flow. The plant stabilizes as follows:

- No operator or protective actions occur.
- Automatic pressure control returns reactor pressure to its initial value.

Ignore any reactivity effects from feedwater injection temperature changes. Compared to the initial operating conditions, current reactor power is approximately \_\_\_\_\_; and current turbine power is approximately \_\_\_\_\_.

- A. the same; 5% lower
- B. the same; the same
- C. 5% higher; 5% lower
- D. 5% higher; the same

**USNRC GENERIC FUNDAMENTALS EXAMINATION  
JUNE 2008 BWR--FORM A**

QUESTION: 37

Refer to the drawing of a tank with a differential pressure (D/P) level detector (see figure below).

If the tank contains 30 feet of water at 60°F, what is the approximate D/P sensed by the detector?

- A. 2 psid
- B. 13 psid
- C. 20 psid
- D. 28 psid

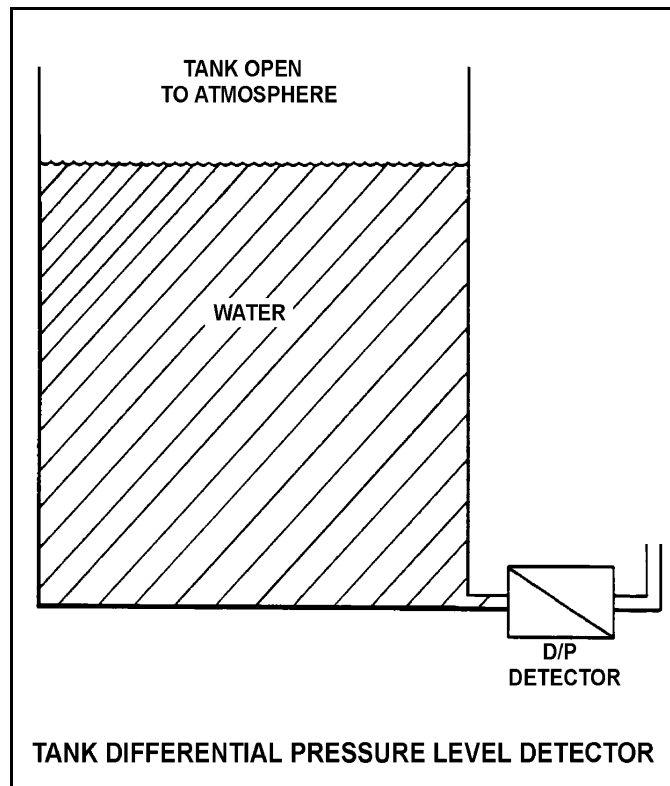

**USNRC GENERIC FUNDAMENTALS EXAMINATION  
JUNE 2008 BWR--FORM A**

QUESTION: 38

A main steam line safety valve is leaking by, allowing 100% quality steam from the reactor vessel to enter the discharge pipe, which remains at a constant pressure of 10 psig. Initial safety valve discharge pipe temperature is elevated but stable. Assume no heat loss from the safety valve discharge pipe.

Upon discovery of the leak, the reactor is shut down and a plant cooldown and depressurization are commenced. As the main steam pressure slowly decreases from 1,000 psig to 800 psig, the safety valve discharge pipe temperature will...

- A. decrease, because the entropy of the safety valve discharge will be decreasing.
- B. decrease, because the enthalpy of the safety valve discharge will be decreasing.
- C. increase, because the safety valve discharge will become more superheated as reactor vessel pressure decreases.
- D. remain the same, because the safety valve discharge will remain a saturated steam-water mixture at 10 psig.

QUESTION: 39

Steam entering an air ejector reaches sonic velocity in the throat of a convergent-divergent nozzle. Upon entering the divergent section of the nozzle, steam velocity will \_\_\_\_\_ and steam pressure will \_\_\_\_\_.

- A. increase; increase
- B. increase; decrease
- C. decrease; increase
- D. decrease; decrease

**USNRC GENERIC FUNDAMENTALS EXAMINATION  
JUNE 2008 BWR--FORM A**

QUESTION: 40

A nuclear power plant was initially operating normally at 90% reactor power when heating steam (extracted from the main turbine) was automatically isolated to several feedwater heaters. Reactor power was returned to 90% and the plant is currently stable.

Compared to the initial main generator MW load, the current main generator MW load is...

- A. lower, because the steam cycle is less efficient.
- B. lower, because less steam is being extracted from the main turbine.
- C. higher, because the steam cycle is less efficient.
- D. higher, because less steam is being extracted from the main turbine.

QUESTION: 41

Which one of the following operating practices minimizes the possibility of water hammer?

- A. Change valve position as rapidly as possible.
- B. Start a centrifugal pump with the discharge valve throttled.
- C. Start a positive displacement pump with the discharge valve closed.
- D. Vent a system only after initiating system flow.

**USNRC GENERIC FUNDAMENTALS EXAMINATION  
JUNE 2008 BWR--FORM A**

QUESTION: 42

Two identical single-speed centrifugal pumps (CPs) and two identical single-speed positive displacement pumps (PDPs) are able to take suction on a vented water storage tank and provide makeup water flow to a cooling water system. The pumps are capable of being cross-connected to provide multiple configurations. In single pump alignment, each pump will supply 100 gpm at a system pressure of 1,200 psig.

Given the following information:

Centrifugal Pumps

Discharge pressure at shutoff head: 1,500 psig  
Maximum design pressure: 2,000 psig  
Flow rate with no backpressure: 180 gpm

Positive Displacement Pumps

Maximum design pressure: 2,000 psig

Which one of the following pump configurations will supply the lowest initial flow rate of makeup water to a cooling water system that is drained and depressurized?

- A. Two CPs in series
- B. Two CPs in parallel
- C. Two PDPs in parallel
- D. One CP and one PDP in series (CP supplying PDP)

**USNRC GENERIC FUNDAMENTALS EXAMINATION  
JUNE 2008 BWR--FORM A**

QUESTION: 43

A condenser is operating at 28.5 inches of Hg vacuum with a condensate outlet temperature of 88°F. Which one of the following is the approximate value of condensate depression?

- A. 2°F
- B. 9°F
- C. 13°F
- D. 17°F

QUESTION: 44

Which one of the following is a characteristic of subcooled nucleate boiling but not saturated nucleate boiling?

- A.  $T_{\text{Clad}}$  equals  $T_{\text{Sat}}$
- B.  $T_{\text{Clad}}$  is greater than  $T_{\text{Sat}}$
- C.  $T_{\text{Bulk Coolant}}$  equals  $T_{\text{Sat}}$
- D.  $T_{\text{Bulk Coolant}}$  is less than  $T_{\text{Sat}}$



**USNRC GENERIC FUNDAMENTALS EXAMINATION  
JUNE 2008 BWR--FORM A**

QUESTION: 45

Which one of the following describes the relative contributions of the convective and radiative modes of heat transfer, and the relationship of  $\Delta T$  ( $T_{\text{wall}} - T_{\text{bulk coolant}}$ ) to heat flux, during stable film boiling heat transfer in the core?

- A. Only radiative heat transfer is significant, and heat flux increases in direct proportion to  $\Delta T$  squared.
- B. Both heat transfer modes are significant, and heat flux increases in direct proportion to  $\Delta T$  squared.
- C. Only radiative heat transfer is significant, and a significant increase in heat flux requires a large  $\Delta T$  increase.
- D. Both heat transfer modes are significant, and a significant increase in heat flux requires a large  $\Delta T$  increase.

QUESTION: 46

Two nuclear reactors, A and B, are operating at rated power with thermal neutron flux radially peaked in the center of each core. The reactors are identical except that reactor A has core orificing and reactor B does not. Both reactors have the same control rod pattern and density.

Compared to the center fuel bundle in reactor B, the center fuel bundle in reactor A will have the \_\_\_\_\_ exit steam quality and the \_\_\_\_\_ critical power.

- A. lower; lower
- B. lower; higher
- C. higher; lower
- D. higher; higher

**USNRC GENERIC FUNDAMENTALS EXAMINATION  
JUNE 2008 BWR--FORM A**

QUESTION: 47

A BWR core consists of 30,000 fuel rods; each fuel rod has an active length of 12 feet. The core is producing 1,800 MW of thermal power. If the total peaking factor for a node is 2.0, what is the maximum local linear power density being produced in the node?

- A. 4.0 kW/ft
- B. 6.0 kW/ft
- C. 8.0 kW/ft
- D. 10.0 kW/ft

QUESTION: 48

Maintaining the linear heat generation rate below the thermal limit ensures that...

- A. peak cladding temperature after the design basis loss of coolant accident will not exceed 2,200°F.
- B. during transients, more than 99.97% of the fuel rods will avoid transition boiling.
- C. plastic strain (deformation) of the cladding will not exceed 1%.
- D. peaking factors will not exceed those assumed in the safety analysis.

**USNRC GENERIC FUNDAMENTALS EXAMINATION  
JUNE 2008 BWR--FORM A**

QUESTION: 49

For a nuclear reactor operating at 100% power, which one of the following combinations of axial power distribution and recirculation system flow rate will result in the smallest critical power ratio in a given fuel bundle? (Assume the maximum linear heat generation rate in the fuel bundle is the same for all cases.)

<u>AXIAL POWER DISTRIBUTION</u>	<u>RECIRCULATION SYSTEM FLOW RATE</u>
A. Top-peaked	Low
B. Top-peaked	High
C. Bottom-peaked	Low
D. Bottom-peaked	High

QUESTION: 50

Two identical nuclear reactors are currently shut down for refueling. Reactor A has an average lifetime power capacity of 60% and has been operating for 15 years. Reactor B has an average lifetime power capacity of 75% and has been operating for 12 years.

Which reactor, if any, will have the lowest reactor vessel nil ductility transition temperature?

- A. Reactor A due to the lower average lifetime power capacity.
- B. Reactor B due to the higher average lifetime power capacity.
- C. Both reactors will have approximately the same nil ductility transition temperature because each core has produced approximately the same number of fissions.
- D. Both reactors will have approximately the same nil ductility transition temperature because fast neutron irradiation in a shut down core is not significant.

**\*\*\*FINAL ANSWER KEY \*\*\***

**JUNE 2008 NRC GENERIC FUNDAMENTALS EXAMINATION  
BOILING WATER REACTOR - ANSWER KEY**

<u>FORM A</u>	<u>FORM B</u>	<u>ANS.</u>	<u>FORM A</u>	<u>FORM B</u>	<u>ANS.</u>
1	15	C	26	40	B
2	16	C	27	41	D
3	17	A	28	42	C
4	18	C	29	43	C
5	19	D	30	44	B
6	20	C	31	45	B
7	21	D	32	46	D
8	22	A	33	47	C
9	23	A	34	48	C
10	24	D	35	49	D
11	25	C	36	50	A
12	26	A	37	1	B
13	27	A	38	2	C
14	28	A	39	3	B
15	29	A	40	4	A
16	30	D	41	5	B
17	31	D	42	6	D
18	32	D	43	7	A
19	33	B	44	8	D
20	34	D	45	9	C
21	35	D	46	10	B
22	36	B	47	11	D
23	37	B	48	12	C
24	38	D	49	13	A
25	39	B	50	14	C