



An Exelon Company

Clinton Power Station  
R. R. 3, Box 228  
Clinton, IL 61727

U-603858

10CFR50.36a

May 27, 2008

U. S. Nuclear Regulatory Commission  
ATTN: Document Control Desk  
Washington, D.C. 20555-0001

Clinton Power Station, Unit 1  
Facility Operating License No. NPF-62  
NRC Docket No. 50-461

Subject: Clinton Power Station  
Addenda to 2005 Annual Radioactive Effluent Release Report

Reference: Letter U-603766 from M.C. McDowell (AmerGen) to U. S. NRC, "Clinton Power Station, 2005 Annual Radioactive Effluent Release Report," dated April 25, 2006

In accordance with Technical Specification (TS) 5.5.1, Offsite Dose Calculation Manual (ODCM), paragraph c., changes to the ODCM shall be submitted to the NRC in the form of a complete, legible copy of the entire ODCM as part of, or concurrent with, the Radioactive Effluent Release Report for the period of the report. The referenced letter contained a description of the changes made to the ODCM, however, a complete copy of the ODCM was not included with the annual report. Attached is a complete copy of the ODCM as required by TS 5.5.1.c.

Respectfully,

M. E. Kanavos  
Plant Manager  
Clinton Power Station

EET/RJC/blf

Attachment

cc: Regional Administrator, Region III  
NRC Senior Resident Inspector - Clinton Power Station  
Office of Nuclear Facility Safety - Illinois Emergency Management Agency

JE48  
NRR

U-603858

Subject: Clinton Power Station  
Addenda to 2005 Annual Radioactive Effluent Release Report

bcc: Clinton Power Station Project Manager - NRR  
Exelon Document Control Desk Licensing  
F. A. Kearney, V-275 (w/o attachment)  
M. E. Kanavos, T-31A (w/o attachment)  
J. T. Conner, T-31A (w/o attachment)  
J. W. Rappeport, T-31C  
C. A. VanDenburgh, T-31Q  
R. J. Campbell, T-31C  
R. Placek (vaulting copy), T-31C

AMERGEN ENERGY COMPANY LLC  
CLINTON POWER STATION  
UNIT 1  
OFFSITE DOSE CALCULATION MANUAL

Docket No. 50-461

AmerGen Energy Company LLC  
 Clinton Power Station  
 OFFSITE DOSE CALCULATION MANUAL

Table of Contents

<u>Section</u>	<u>Title</u>	<u>Page</u>
1.0	PREFACE	1-1
1.1	Definitions	1-1
1.2	General Operation Requirements	1-4
1.3	General Surveillance Requirements	1-5
1.4	Effluent Concentration Limit (ECL) Calculation Requirements	1-6
2.0	LIQUID EFFLUENTS	
2.1	Introduction	2-1
2.2	Liquid Radwaste Discharge Process Radiation Monitoring (PRM) System	2-1
2.3	10CFR20 Release Rate Limits	2-1
	2.3.1 Liquid Effluent Concentration - Operation and Surveillance Requirements	2-2
	2.3.2 Liquid Radwaste Discharge PRM Setpoints	2-6
	2.3.3 Plant Service Water Effluent PRM Setpoints	2-11
	2.3.4 Shutdown Service Water (SX) Effluent PRM Setpoints	2-12
	2.3.5 Fuel Pool Heat Exchanger Service Water Effluent PRM Setpoints	2-12
	2.3.6 Component Cooling Water PRM Setpoints	2-12

AmerGen Energy Company LLC  
 Clinton Power Station  
 OFFSITE DOSE CALCULATION MANUAL

Table of Contents

<u>Section</u>	<u>Title</u>	<u>Page</u>
2.0	2.4 10CFR50, Appendix I Release Rate Limits	2-13
	2.4.1 10CFR50, Appendix I Release Rate Limits - Operation and Surveillance Requirements	2-13
	2.4.2 Discussion	2-14
	2.5 Liquid Radwaste Treatment System	2-24
	2.5.1 Liquid Radwaste Treatment System - Operation and Surveillance Requirements	2-24
	2.5.2 Temporary Liquid Radwaste Hold-up Tanks	2-25
	2.6 Doses From Other Significant Liquid Effluent Pathways	2-25
	2.7 Radioactive Liquid Effluent Monitoring Instrumentation	2-26
	2.7.1 Radioactive Liquid Effluent Monitoring Instrumentation-Operation and Surveillance Requirements	2-26
3.0	GASEOUS EFFLUENTS	3-1
	3.1 Introduction	3-1
	3.2 Gaseous Effluent Release Point Monitoring	3-2
	3.2.1 HVAC Stack Process Radiation Monitoring (PRM) System	3-2
	3.2.2 SGTS Stack Process Radiation Monitoring (PRM) System	3-2

AmerGen Energy Company LLC  
 Clinton Power Station  
 OFFSITE DOSE CALCULATION MANUAL

Table of Contents

<u>Section</u>	<u>Title</u>	<u>Page</u>
3.0	3.3 Main Condenser Off-Gas Monitoring System	3-3
	3.3.1 Pre-Treatment Air Ejector Off-Gas Process Radiation Monitor (PRM)	3-3
	3.3.2 Post-Treatment Air Ejector Off-Gas Process Radiation Monitor (PRM)	3-4
	3.4 10CFR20 Release Rate Limits	3-4
	3.4.1 10CFR20 Release Rate Limits - Operation and Surveillance Requirements	3-5
	3.4.2 Dose Rate Due to Noble Gases	3-9
	3.4.3 Dose Rate Due to Radioiodines, Particulates and Tritium	3-9
	3.5 10CFR50, Appendix I Release Rate Limits	3-14
	3.5.1 Noble Gas Dose - Operation and Surveillance Requirements	3-14
	3.5.2 Iodine-131, Iodine-133, Tritium, and Radionuclides in Particulate Form - Operations and Surveillance Requirements	3-15
	3.5.3 Noble Gas Air Dose Equations	3-16
	3.5.4 Radioiodines, Particulates and Tritium Dose Equations	3-17
	3.6 Gaseous Radwaste (Offgas Treatment	3-25
	3.6.1 Gaseous Radwaste (Offgas Treatment) System - Operation and Surveillance Requirements	3-25

## AmerGen Energy Company LLC

## Clinton Power Station

## OFFSITE DOSE CALCULATION MANUAL

Table of Contents

<u>Section</u>	<u>Title</u>	<u>Page</u>
3.0	3.7 Ventilation Exhaust Treatment	3-26
	3.7.1 Ventilation Exhaust Treatment System - Operation and Surveillance Requirements	3-26
	3.7.2 Gaseous Effluent Dose Projection Calculations	3-27
	3.8 Effluent Monitor Setpoint Calculations	3-27
	3.8.1 Total Body Dose Rate Setpoint	3-28
	3.8.2 Skin Dose Rate Setpoint	3-29
	3.9 Radioactive Gaseous Monitoring Instrumentation	3-30
	3.9.1 Offgas Radiation Monitoring Instrumentation - Operation and Surveillance Requirements	3-30
	3.9.2 Radioactive Gaseous Effluent Monitoring Instrumentation - Operation and Surveillance Requirements	3-37
4.0	COMPLIANCE WITH 40CFR190	4-1
	4.1 Total Dose - Operation and Surveillance Requirements	4-1
	4.1.a Remedial Requirement	4-1
5.0	RADIOLOGICAL ENVIRONMENTAL MONITORING PROGRAM	5-1
	5.1 Monitoring Program - Operation and Surveillance Requirements	5-2
	5.2 Land Use Census - Operation and Surveillance Requirements	5-21

AmerGen Energy Company LLC  
Clinton Power Station  
OFFSITE DOSE CALCULATION MANUAL

Table of Contents

<u>Section</u>	<u>Title</u>	<u>Page</u>
5.0	5.3 Interlaboratory Comparison Program	5-22
	5.3.1 Interlaboratory Comparison Program - Operation and Surveillance Requirements	5-23
6.0	BASES FOR OPERATION AND SURVEILLANCE REQUIREMENTS	6-1
	6.1 General Operation and Surveillance Requirements	6-1
	6.2 Monitoring Instrumentation	6-2
	6.3 Radioactive Effluents	6-3
	6.3.1 Liquid Effluents	6-3
	6.3.2 Gaseous Effluents	6-5
	6.3.3 Total Dose	6-9
	6.4 Radiological Environmental Monitoring	6-10
7.0	REPORTING REQUIREMENTS	7-1
	7.1 Annual Radiological Environmental Operating Report	7-1
	7.2 Radioactive Effluent Release Report	7-2
8.0	ADJUSTMENT OF THE CPS ODCM METHODOLOGY	8-1
9.0	ATMOSPHERIC TRANSPORT AND DISPERSION MODEL	9-1
	9.1 Introduction	9-1



AmerGen Energy Company LLC  
 Clinton Power Station  
 OFFSITE DOSE CALCULATION MANUAL

Table of Contents

<u>Section</u>	<u>Title</u>	<u>Page</u>
9.0	9.2 Concurrent Meteorological Data Processing	9-1
	9.2.1 Determination of Pasquill Stability Class	9-2
	9.2.2 Calculation of Stack Height Wind Speed	9-3
	9.2.3 Determination of Release Mode and the Entrainment Coefficient	9-3
	9.2.4 Calculation of Vertical Standard Deviation	9-4
	9.2.5 Calculation of the Building Wake Correction	9-5
	9.2.6 Calculation of Momentum Plume Rise	9-5
	9.2.7 Calculation of Effective Plume Height	9-6
	9.2.8 Determination of Affected Sectors	9-7
	9.2.9 Calculation of Depletion and Deposition Factors	9-8
	9.2.10 Ground Level X/Q, D2DPXQ, D1XQ, D/Q Analysis	9-10
	9.2.11 Elevated X/Q, D2DPXQ, D1XQ, D/Q Analysis	9-11

## AmerGen Energy Company LLC

## Clinton Power Station

## OFFSITE DOSE CALCULATION MANUAL

Tables

<u>Table</u>	<u>Title</u>	<u>Page</u>
1.1-1	Surveillance Frequency Notation	1-6
2.3-1	Radioactive Liquid Waste Sampling and Analysis Program	2-3
2.4-1	Adult Ingestion Dose Commitment Factors - $A_{ij}$	2-16
2.4-2	Bioaccumulation Factors - $BF_i$	2-18
2.4-3	Adult Ingestion Dose Factors - $DF_i$	2-19
2.7-1	Radioactive Liquid Effluent Monitoring Instrumentation	2-27
2.7-2	Radioactive Liquid Effluent Monitoring Instrumentation Surveillance Requirements	2-30
3.4-1	Radioactive Gaseous Waste Sampling and Analysis Program	3-6
3.4-2	Dose Factors for Noble Gases and Daughters	3-11
3.4-3	Inhalation Pathway Dose Rate Factors (Child) - $P_{ij}$	3-12
3.4-4	Location of Members of the Public Within the CPS Site Boundary and Their Associated Occupancy Factors	3-13
3.9.1-1	Offgas Radiation Monitoring Instrumentation	3-31
3.9.1-2	Offgas Radiation Monitoring Instrumentation Surveillance Requirements	3-35
3.9.2-1	Radioactive Gaseous Effluent Monitoring Instrumentation	3-38
3.9.2-2	Radioactive Gaseous Effluent Monitoring Instrumentation Surveillance Requirements	3-40
3.5-1	Inhalation Dose Factors for Infant- $(DFA_i)_a$	3-44
3.5-2	Inhalation Dose Factors for Child- $(DFA_i)_a$	3-45
3.5-3	Inhalation Dose Factors for Teen- $(DFA_i)_a$	3-46

## AmerGen Energy Company LLC

## Clinton Power Station

## OFFSITE DOSE CALCULATION MANUAL

Tables

<u>Table</u>	<u>Title</u>	<u>Page</u>
3.5-4	Inhalation Dose Factors for Adult- $(DFA_i)_a$	3-47
3.5-5	Ground Plane Dose Factors- $DFG_i$	3-48
3.5-6	Ingestion Dose Factors for Infant- $(DFL_i)_a$	3-49
3.5-7	Ingestion Dose Factors for Child- $(DFL_i)_a$	3-50
3.5-8	Ingestion Dose Factors for Teen- $(DFL_i)_a$	3-51
3.5-9	Ingestion Dose Factors for Adult- $(DFL_i)_a$	3-52
3.5-10	Input Parameters for Calculating $R_{ija}^C$	3-53
3.5-11	Input Parameters for Calculating $R_{ija}^M$	3-54
3.5-12	Input Parameters for Calculating $R_{ija}^V$	3-55
3.5-13	Inhalation Pathway Factors - $R_{ija}^I$ (INFANT)	3-56
3.5-14	Inhalation Pathway Factors - $R_{ija}^I$ (CHILD)	3-57
3.5-15	Inhalation Pathway Factors - $R_{ija}^I$ (TEEN)	3-58
3.5-16	Inhalation Pathway Factors - $R_{ija}^I$ (ADULT)	3-59
3.5-17	Cow Milk Pathway Factors - $R_{ija}^C$ (INFANT)	3-60
3.5-18	Cow Milk Pathway Factors - $R_{ija}^C$ (CHILD)	3-61
3.5-19	Cow Milk Pathway Factors - $R_{ija}^C$ (TEEN)	3-62
3.5-20	Cow Milk Pathway Factors - $R_{ija}^C$ (ADULT)	3-63
3.5-21	Goat Milk Pathway Factors - $R_{ija}^C$ (INFANT)	3-64
3.5-22	Goat Milk Pathway Factors - $R_{ija}^C$ (CHILD)	3-65
3.5-23	Goat Milk Pathway Factors - $R_{ija}^C$ (TEEN)	3-66
3.5-24	Goat Milk Pathway Factors - $R_{ija}^C$ (ADULT)	3-67
3.5-25	Meat Pathway Factors - $R_{ija}^M$ (CHILD)	3-68
3.5-26	Meat Pathway Factors - $R_{ija}^M$ (TEEN)	3-69
3.5-27	Meat Pathway Factors - $R_{ija}^M$ (ADULT)	3-70

## AmerGen Energy Company LLC

## Clinton Power Station

## OFFSITE DOSE CALCULATION MANUAL

Tables

<u>Table</u>	<u>Title</u>	<u>Page</u>
3.5-28	Vegetation Pathway Factors - $R_{ija}^V$ (CHILD)	3-71
3.5-29	Vegetation Pathway Factors - $R_{ija}^V$ (TEEN)	3-72
3.5-30	Vegetation Pathway Factors - $R_{ija}^V$ (ADULT)	3-73
3.5-31	Ground Plane Pathway Factors - $R_i^G$	3-74
5.1-1	Radiological Environmental Monitoring Program	5-4
5.1-2	Reporting Levels for Radioactivity Concentrations in Environmental Samples	5-17
5.1-3	Detection Capabilities for Environmental Sample Analysis Lower Limit of Detection (LLD)	5-18
9.2-1	$\sigma_z$ Values	9-4
9.2-2	Wind Direction Tables	9-7
9.2-3	DPF Depletion Factors	9-8
9.2-4	DPSF Deposition Factors	9-9
9.2-5	Gaseous Effluent Release Point Characteristics	9-13

AmerGen Energy Company LLC  
Clinton Power Station

## OFFSITE DOSE CALCULATION MANUAL

Figures

<u>Figure</u>	<u>Title</u>	<u>Page</u>
2.1-1	Unrestricted Area Boundary for Liquid Effluents	2-10
2.5-1	Liquid Radwaste Treatment System	2-21
2.5-2	Shutdown and Fuel Pool Heat Exchanger Service Water Effluent Monitors	2-22
2.5-3	Solid Radwaste System Simplified Flow Diagram	2-23
3.1-1	CPS Site Boundary For Gaseous Effluents	3-42
3.3-1	Main Condenser Off-Gas Treatment System	3-43
5.0-1	REMP Locations Within 1 Mile of CPS	5-24
5.0-2	REMP Location 1-2 Miles From CPS	5-25
5.0-3	REMP Location 2-5 Miles From CPS	5-26
5.0-4	REMP Locations Greater than 5 Miles From CPS	5-27

1.0 GENERAL INFORMATION

PREFACE

The Clinton Power Station OFFSITE DOSE CALCULATION MANUAL (CPS-ODCM) provides the methodologies and parameters to be used by AmerGen Energy Company LLC to assure compliance with the radioactive effluent dose limitations stated in 10CFR20, 10CFR50 Appendix A (General Design Criteria 60 and 64), 10CFR50 Appendix I, and 40CFR190.

The CPS-ODCM was prepared based on guidance provided in NUREG-0133, PREPARATION OF RADIOLOGICAL EFFLUENT TECHNICAL SPECIFICATIONS FOR NUCLEAR POWER PLANTS (October 1978), and NUREG-0473, RADIOLOGICAL EFFLUENT TECHNICAL SPECIFICATIONS FOR BOILING WATER REACTORS (Draft 7, to Revision 3). This manual along with station procedures will be used by CPS personnel to demonstrate compliance with the above referenced Federal Regulations.

Changes to the CPS-ODCM shall be provided in the RADIOACTIVE EFFLUENT RELEASE REPORT.

1.1 Definitions

The following terms are defined so that uniform interpretation of requirements of this manual may be achieved. The defined terms appear in capitalized type and shall be applicable throughout this manual.

CHANNEL CALIBRATION

- 1.1.1 A CHANNEL CALIBRATION shall be the adjustment, as necessary, of the channel output such that it responds with the necessary range and accuracy to known values of the parameter that the channel monitors. The CHANNEL CALIBRATION shall encompass the entire channel, including the required sensor, alarm, display, and trip functions, and shall include the CHANNEL FUNCTIONAL TEST. Calibration of instrument channels with resistance temperature detector (RTD) or thermocouple sensors may consist of an in place qualitative assessment of sensor behavior and normal calibration of the remaining adjustable devices in the channel. The CHANNEL CALIBRATION may be performed by means of any series of sequential, overlapping or total channel steps so that the entire channel is calibrated.

CHANNEL CHECK

- 1.1.2 A CHANNEL CHECK shall be the qualitative assessment, by observation, of channel behavior during operation. This determination shall include, where possible, comparison of the channel indication and status to other indications or status derived from independent instrument channels measuring the same parameter.

CHANNEL FUNCTIONAL TEST

- 1.1.3 A CHANNEL FUNCTIONAL TEST shall be the injection of a simulated, or actual, signal into the channel as close to the sensor as practicable to verify OPERABILITY, including required alarm, interlock, display, and trip functions, and channel failure trips. The CHANNEL FUNCTIONAL TEST may be performed by means of any series of sequential, overlapping or total channel steps so that the entire channel is tested.

FREQUENCY NOTATION

- 1.1.4 The FREQUENCY NOTATION specified for the performance of surveillance requirements shall correspond to the intervals defined in Table 1.1-1.

GASEOUS RADWASTE TREATMENT SYSTEM

- 1.1.5 A GASEOUS RADWASTE TREATMENT SYSTEM is any system designed and installed to reduce radioactive gaseous effluents by collecting primary coolant system offgases from the main condenser evacuation system and providing for delay or holdup for the purpose of reducing the total radioactivity prior to release to the environment.

MEMBER(S) OF THE PUBLIC

- 1.1.6 An individual in a controlled or unrestricted area. However, an individual is not a member of the public during any period in which the individual receives an occupational dose.

- 1.1.7 MODE

A MODE shall correspond to any one inclusive combination of mode switch position, average reactor coolant temperature, and reactor vessel head bolt tensioning specified in Technical Specification Table 1.1-1 with fuel in the reactor vessel.

OPERABLE - OPERABILITY

- 1.1.8 A system, subsystem, division, component or device shall be OPERABLE or have OPERABILITY when it is capable of performing its specified safety function(s) and when all necessary attendant instrumentation, controls, normal or emergency electrical power, cooling or seal water, lubrication or other auxiliary equipment that are required for the system, subsystem, division, component or device to perform its specified safety function(s) are also capable of performing their related support function(s).

REMEDIAL REQUIREMENT

- 1.1.9 REMEDIAL REQUIREMENT shall be that part of a requirement which prescribes remedial measures required under designated conditions.

SITE BOUNDARY

- 1.1.10 The SITE BOUNDARY shall be that line beyond which the land is neither owned, nor leased, nor otherwise controlled by the licensee.

SOURCE CHECK

- 1.1.11 A SOURCE CHECK shall be the qualitative assessment of channel response when the channel sensor is exposed to a source of increased radioactivity.

UNRESTRICTED AREA

- 1.1.12 An UNRESTRICTED AREA means an area, access to which is neither limited nor controlled by the licensee.

VENTILATION EXHAUST TREATMENT SYSTEM

- 1.1.13 A VENTILATION EXHAUST TREATMENT SYSTEM is any system designed and installed to reduce gaseous radioiodine or radioactive material in particulate form in effluents by passing ventilation or vent exhaust gases through charcoal adsorbers and/or HEPA filters for the purpose of removing iodines or particulates from the gaseous exhaust stream prior to the release to the environment. Such a system is not considered to have any effect on noble gas effluents. Engineered Safety Feature (ESF) atmospheric cleanup systems are not considered to be VENTILATION EXHAUST TREATMENT SYSTEM components.



The following systems are designated VENTILATION EXHAUST TREATMENT SYSTEMS:

- 1) Machine Shop HVAC (VJ)
- 2) Laboratory HVAC (VL)
- 3) Drywell Purge (VQ)
- 4) Radwaste Bldg. HVAC (VW)

1.1.14 The MCR ARPR LAN is the means whereby data is transmitted from the ARPR monitors to the central collection equipment. Terminal 1H13-P870 is normally the Master Terminal. Terminals 1H13-P864 and the terminal in the TSC may also be used to fulfill MCR ARPR LAN related functions if the conditions stated in the appropriate sections of the ODCM are met.

The communication requirements for the MCR ARPR LAN will be satisfied if communication is verified at either the 1H13-P864 terminal or the 1H13-P870 terminal with either terminal being designated as the Master Terminal. In the event communication cannot be verified at either the 1H13-P864 or the 1H13-P870 terminals, communication with the MCR ARPR LAN requirements can be satisfied using the TSC terminal if the TSC terminal is manned continuously, if direct/constant communication is established with MCR personnel, and the TSC terminal has been designated as the Master Terminal. Channel Functional Test/Calibration requirements can be satisfied at the 1H13-P864 terminal if terminal 1H13-P870 is designated as the Master Terminal. The TSC terminal may also be used to satisfy Channel Functional Test/Calibration requirements if the requirements previously given for use of this terminal are met.

## 1.2 General Operation Requirements

1.2.1 Operation Requirements shall be met during the conditions specified therein; except as provided in Operation Requirement 1.2.2.

1.2.2 Upon discovery of a failure to meet an Operation Requirement, the REMEDIAL REQUIREMENT(s) shall be met, except as provided in 1.2.3.

If the Operation Requirement is met or is no longer applicable prior to expiration of the REMEDIAL REQUIREMENT(s), completion of the REMEDIAL REQUIREMENT(s) is not required, unless otherwise stated.

1.2.3 Equipment removed from service or declared inoperable to comply with REMEDIAL REQUIREMENT(s) may be returned to service under administrative control solely to perform testing required to demonstrate OPERABILITY or the OPERABILITY of other equipment. This is an exception to OPERATION REQUIREMENT 1.2.2 for the system returned to service under administrative control to perform the testing required to demonstrate OPERABILITY.

1.3 General Surveillance Requirements

1.3.1 Surveillance Requirements shall be met during the applicable conditions specified in and for the associated Operation Requirement, unless otherwise stated in the Surveillance Requirement. Failure to meet a Surveillance, whether such failure is experienced during the performance of the surveillance, or between performances of the Surveillance, shall be failure to meet the Operation Requirement.

1.3.2 The specified surveillance interval for each Surveillance Requirement is met if the Surveillance is performed within 1.25 times the specified surveillance interval, as measured from the previous performance or as measured from the time a specified condition of the Surveillance Requirement is met.

For surveillance intervals specified as "once", the above interval extension does not apply.

If a REMEDIAL REQUIREMENT requires periodic performance on a "once per ..." basis, the above surveillance interval extension applies to each performance after the initial performance.

Exceptions to this Surveillance Requirement are stated in the individual Surveillance Requirements.

Failure to perform a surveillance within the specified time interval shall be a failure to meet the Operation Requirement except as provided in Surveillance Requirement 1.3.3. Surveillances do not have to be performed on inoperable equipment or variables outside specified limits.

1.3.3 If it is discovered that a surveillance was not performed within its specified surveillance interval, then compliance with the requirement to declare the Operational Requirement not met may be delayed, from the time of discovery, up to 24 hours or up to the limit of the specified interval, whichever is less. This delay period is to allow performance of the surveillance.

If the surveillance is not performed within the delay period, the Operational Requirement must immediately be declared not met, and the applicable REMEDIAL REQUIREMENTS must be met.

1.4 Effluent Concentration Limit (ECL) Calculation Requirements

- 1.4.1 Ten times the values found in 10CFR20 Appendix B, Table 2, Column 2 shall be used for all ECL calculations in the ODCM. For dissolved or entrained noble gases, the concentration shall be limited to  $2.0 \times 10^{-4}$  microcuries/ml total activity.

TABLE 1.1-1

SURVEILLANCE FREQUENCY NOTATION

<u>NOTATION</u>	<u>FREQUENCY</u>
S	At least once per 12 hours.
D	At least once per 24 hours.
W	At least once per 7 days.
M	At least once per 31 days.
Q	At least once per 92 days.
SA	At least once per 184 days.
A	At least once per 366 days.
R	At least once per 18 months (550 days)
R24	At least once per 24 months (732 days)
P	Prior to each release.
S/U	Prior to each reactor startup.
NA	Not applicable.

Note: A frequency notation for a composite sample describes the time period over which the sample is to be composited.

2.0 LIQUID EFFLUENTS

2.1 Introduction

Liquid radwaste effluent released from CPS will meet ten times the 10CFR20 concentration limits at the point of discharge to the unrestricted area shown in Figure 2.1-1. This design and operation objective will be achieved at all times. Actual discharges of liquid radwaste effluent will normally occur on a batch basis and the average concentration at the point of discharge will be only a small percentage of the allowed limits. Refer to Clinton USAR Section 11.5 for a description of radiation monitoring, sampling and effluent control systems.

Cumulative quarterly dose contributions due to radioactive effluents released to the unrestricted area will be determined once every 31 days using NUREG-0133 and Regulatory Guide 1.109 methodology and parameters during periods when liquid effluent activity exceeds the Lower Limit of Detection (LLD) values.

2.2 Liquid Radwaste Discharge Process Radiation Monitoring (PRM) System

This monitoring subsystem measures liquid radwaste effluent radioactivity prior to the effluent joining plant service water and circulating water dilution streams. A high radioactivity signal from this gamma scintillation detector automatically terminates the liquid radwaste effluent release. The liquid radwaste effluent flow, variable from 10-60 GPM or 50-300 GPM, combines with Plant Service Water flow (minimum flow approximately 2000 GPM during plant shutdown periods depending on system loads) and Plant Circulating Water flow (0-567,000 GPM) in the Seal Well prior to entering the 3.4-mile discharge flume to Lake Clinton (see Figure 2.5-1).

2.3 10CFR20 Release Rate Limits

The Operation and Surveillance Requirements pertaining to discharge of liquid radwaste effluent to the unrestricted area are specified in Section 2.3.1 as follows.

2.3.1 Liquid Effluent Concentration - Operation and Surveillance Requirements

OPERATION REQUIREMENT

The concentration of radioactive material released in liquid effluent to UNRESTRICTED AREAS (see Figure 2.1-1) shall be limited to ten times the concentrations specified in 10CFR Part 20, Appendix B, Table 2, Column 2 for radionuclides other than dissolved or entrained noble gases. For dissolved or entrained noble gases, the concentration shall be limited to 2.00E-04 microcuries/ml total activity. This requirement applies during all releases via this pathway.

REMEDIAL REQUIREMENT:

With the concentration of radioactive material released in liquid effluents to UNRESTRICTED AREAS exceeding the above limits, immediately restore the concentration to within the above limits.

SURVEILLANCE REQUIREMENTS

2.3.1.1 Radioactive liquid wastes shall be sampled and analyzed according to the sampling and analysis program of Table 2.3-1.

2.3.1.2 The results of the radioactivity analyses shall be used in accordance with the methodology and parameters of Section 2.3.2 to assure that the concentrations at the point of release are maintained within the limits of the above Operation Requirement.

To comply with the above requirements, setpoints will be calculated to assure that Seal Well concentrations do not exceed the OPERATIONAL REQUIREMENT specified in section 2.3.1.

TABLE 2.3-1

## RADIOACTIVE LIQUID WASTE SAMPLING AND ANALYSIS PROGRAM

LIQUID RELEASE TYPE	SAMPLING FREQUENCY	MINIMUM ANALYSIS FREQUENCY	TYPE OF ACTIVITY ANALYSIS	LOWER LIMIT OF DETECTION (LLD) <sup>a</sup> ( $\mu\text{Ci/ml}$ )
Batch Waste Release Tanks <sup>b</sup>	P Each Batch	P Each Batch	Principal Gamma Emitters <sup>c</sup>	$\leq 5.00\text{E-}07$
			I-131	$\leq 1.00\text{E-}06$
	P One Batch/M	M	Dissolved and Entrained Gases <sup>e</sup> (Gamma Emitters)	$\leq 1.00\text{E-}05$
	P Each Batch	Q Composite <sup>d</sup>	H-3	$\leq 1.00\text{E-}05$
			Gross Alpha	$\leq 1.00\text{E-}07$
	P Each Batch	Q Composite <sup>d</sup>	Sr-89, Sr-90	$\leq 5.00\text{E-}08$
			Fe-55	$\leq 1.00\text{E-}06$

TABLE 2.3-1 (Continued)RADIOACTIVE LIQUID WASTE SAMPLING AND ANALYSIS PROGRAMTABLE NOTATIONS

<sup>a</sup>The LLD is defined, for purposes of these requirements, as the smallest concentration of radioactive material in a sample that will yield a net count, above system background, that will be detected with 95% probability with only 5% probability of falsely concluding that a blank observation represents a "real" signal.

For a particular measurements system, which may include radiochemical separation:

$$LLD = 4.66 s_b / [E \times V \times 2.22E+06 \times Y \times \exp^{-\lambda \Delta t}]$$

Where:

LLD is the "a priori" lower limit of detection as defined above, as microcuries per unit mass or volume,

$s_b$  is the standard deviation of the background counting rate or of the counting rate of a blank sample as appropriate, as counts per minute.

E is the counting efficiency, as counts per disintegration,

V is the sample size in units of mass or volume,

2.22E+06 is the number of disintegrations per minute per microcurie,

Y is the fractional radiochemical yield, when applicable,

$\lambda$  is the radioactive decay constant for the particular radionuclide ( $\text{sec}^{-1}$ ) and

$\Delta t$  for plant effluents is the elapsed time between the midpoint of sample collection and the midpoint of the counting interval (sec).

Typical values of E, V, Y and  $\Delta t$  should be used in the calculation.

TABLE 2.3-1 (Continued)RADIOACTIVE LIQUID WASTE SAMPLING AND ANALYSIS PROGRAMTABLE NOTATIONS (Continued)

It should be recognized that the LLD is defined as an a priori (before the fact) limit representing the capability of a measurement system and not as an a posteriori (after the fact) limit for a particular measurement.

<sup>b</sup>A batch release is the discharge of liquid wastes of a discrete volume. Prior to sampling for analyses, the tank is isolated from all inputs and recirculated a minimum of two tank volumes at which time a sample is obtained for isotopic analysis.

<sup>c</sup>The principal gamma emitters are: Mn-54, Fe-59, Co-58, Co-60, Zn-65, Mo-99, Cs-134, Cs-137, and Ce-141. Ce-144 shall also be measured, but with an LLD of  $\leq 5.00E-06$   $\mu\text{Ci/ml}$ . All identified radionuclides shall be reported in the Radioactive Effluent Release Report pursuant to Technical Specification 5.6.3 in a format outlined in Regulatory Guide 1.21, Appendix B, Revision 1, June 1974.

<sup>d</sup>A composite sample is one in which the quantity of liquid sampled is proportional to the quantity of liquid waste discharged and in which the method of sampling employed results in a specimen that is representative of the liquids released.

<sup>e</sup>Dissolved and Entrained gases are: Xe-133, Xe-135, Xe-138, Kr-85m, Kr-87, and Kr-88.



2.3.2 Liquid Radwaste Discharge PRM Setpoints

To comply with the Operation Requirements of Section 2.3.1 and Section 2.7.1, the alarm/trip setpoints for liquid effluent monitors and flow measurement devices are set to assure that the following equation is satisfied:

$$cf/(F + f) \leq ECL \quad (1)$$

ECL = the Effluent Concentration Limit (Section 2.3.1) implementing 10 times the effluent concentration limit of 10CFR20, Appendix B, Table 2, Column 2 and corresponding to the specific mix of radionuclides in the effluent stream being considered, in  $\mu\text{Ci/ml}$

c = the setpoint, in  $\mu\text{Ci/ml}$ , of the radioactivity monitor measuring the radioactivity concentration in the effluent line prior to dilution and subsequent release; the setpoint is inversely proportional to the volumetric flow of the effluent line and proportional to the volumetric flow of the dilution stream(s) plus the effluent stream.

F = the dilution water flow setpoints as determined at the Seal Well, in volume per unit time

f = the liquid radwaste discharge flow setpoint as determined at the liquid radwaste discharge PRM location, in volume per unit time (same units as F)

The available dilution water flow (F) should be constant for a given release, and the liquid radwaste tank discharge flow (f) and monitor setpoint (c) are set to meet the condition of equation (1) for a given effluent concentration (ECL). The method by which this is accomplished is illustrated in sections 2.3.2.1 through 2.3.2.5.

2.3.2.1 The isotopic concentration for a liquid radwaste tank to be discharged is obtained from the sum of the measured concentrations as determined by the analyses required in Table 2.3-1:

$$\sum_i C_i = \sum_g C_g + \sum_a C_a + \sum_s C_s + C_T + C_{Fe}, \quad \mu\text{Ci/ml} \quad (2)$$

where

$\sum_g C_g$  = The sum of concentrations  $C_g$  of each measured gamma emitter  $g$  (including I-131) observed by gamma spectroscopy of the waste sample,  $\mu\text{Ci/ml}$ .

$\sum_a C_a$  = The sum of concentrations  $C_a$  of alpha emitters (a) in liquid radwaste as measured in the most current QUARTERLY composite discharge tank sample,  $\mu\text{Ci/ml}$ .

$\sum_s C_s$  = The sum of concentrations  $C_s$  of Sr-89/Sr-90 in liquid radwaste as observed in the most current QUARTERLY composite discharge tank sample,  $\mu\text{Ci/ml}$ .

$C_T$  = The measured concentration of H-3 in liquid radwaste as determined from analysis of the most current QUARTERLY composite discharge tank sample,  $\mu\text{Ci/ml}$ .

$C_{Fe}$  = The measured concentration of Fe-55 in liquid radwaste as observed in the most current QUARTERLY composite discharge tank sample,  $\mu\text{Ci/ml}$ .

2.3.2.2 The measured radionuclide concentrations are used to calculate a DILUTION FACTOR (DF) which is equivalent to the ratio of total dilution flow rate to liquid radwaste tank effluent flow rate required to assure that the limiting concentrations specified in Operational Requirement 2.3.1 are met at the point of discharge to the unrestricted area.

$$D_{\text{req},g} = \frac{\sum_{i=g} C_i}{f * R_{\text{max}} ECL_i}$$

$$D_{\text{req},ng} = \frac{\sum_{i=ng} C_i}{f * R_{\text{max}} ECL_i}$$

$$D_{\text{req}} = D_{\text{req},g} + D_{\text{req},ng} \quad (3)$$

where

$D_{\text{req},g}$  = Required dilution factor for gamma emitters

$D_{\text{req},ng}$  = Required dilution factor for non-gamma emitters

$ECL_i$  = Effluent concentration limit of nuclide  $i$  in  $\mu\text{Ci/ml}$  equal to 10 times the values in 10CFR20 Appendix B, Table 2, Column 2 for radionuclides other than dissolved or entrained noble gases. For dissolved or entrained noble gases, the concentration is limited to  $2.00E-04 \mu\text{Ci/ml}$ .

$f$  = Release point safety factor

$R_{max}$  = The maximum ECL ratio from the release point setpoint definition

$C_i$  = The concentration of nuclide  $i$  in  $\mu\text{Ci/ml}$

SF = The conservative SAFETY FACTOR normally applied to compensate for statistical fluctuations and measurement errors, dimensionless.

2.3.2.3 The maximum permissible liquid radwaste tank effluent flow rate,  $R_{cwmax}$ , is calculated by the following equation:

$$R_{cwmax} = \frac{F_{avail} + (f_{alloc} * F_{waste})}{D_{req}}, \text{ volume/time} \quad (4)$$

where

$R_{cwmax}$  = Maximum waste flow rate

$F_{avail}$  = Minimum expected dilution water flow rate (Circulating and/or Service Water systems), volume/time

$f_{alloc} = 0.9$  = Flow rate correction factor to provide a 10% margin for variations in flow rates, dimensionless

$F_{waste}$  = Maximum expected liquid radwaste tank effluent flow rate, volume/time

$D_{req}$  = The DILUTION FACTOR calculated by equation (3), dimensionless

Equation (4) is valid only for  $DF \geq 1$ . For  $DF < 1$ , the liquid radwaste tank effluent concentration meets the limits of Operational Requirement 2.3.1 without dilution and therefore  $R_{cwmax}$  may assume any value not to exceed discharge pump capacity.

2.3.2.4 The liquid radwaste discharge PRM setpoint may now be specified based on the values of  $\sum_i C_i$  (Eq.2) and  $R_{cwmax}$  (Eq.4) which were determined to provide compliance with the concentration limits of Operational Requirement 2.3.1. The monitor response is primarily a gamma response and the actual setpoint is therefore based on  $\sum_g C_g$  (Eq.2). The monitor setpoint, in counts per minute (cpm), which corresponds to the particular setpoint concentration,  $S_{max}$ , is determined based on monitor calibration data or operational data which correlates monitor response to sample analyses associated with the actual liquid radwaste discharged. The use of operational data is considered valid only if the integrity of laboratory methods of determination are proven more accurate than the monitor data.

The set point concentration,  $S_{\max}$ , is obtained by the following equations:

$$S_{\text{adj}} = \frac{R_{\text{cwmax}}}{F_{\text{waste}}} \quad (5)$$

$$S_{\max} = S_{\text{adj}} * \sum_g C_g \quad (6)$$

where

$F_{\text{waste}}$  = The actual liquid radwaste effluent flow rate, volume/time

$R_{\text{cwmax}}$  and  $F_{\text{waste}}$  are defined in section 2.3.2.3.

If  $S_{\text{adj}} \geq 1$ , the value obtained for  $S_{\max}$  is used to determine the monitor setpoint above background, ccpm, from either of the two methods described above. In the case where  $S_{\text{adj}} < 1$ , no release may be made using the existing discharge parameter values ( $R_{\text{cwmax}}$ ,  $F_{\text{waste}}$ ).

The setpoint concentration is conservative, even if  $R_{\text{cwmax}}$  is attainable, since the calculated flow rate contains the SAFETY FACTOR, dilution flow rate and liquid radwaste tank effluent flow rate margins.

- 2.3.2.5 To prevent spurious alarms, revise the Plant Service Water Effluent PRM setpoint to coincide with the setpoint concentration,  $S_{\max}$ , calculated by equation (6). This setpoint is valid only during periods of actual liquid radwaste discharges.

FIGURE 2.1-1

UNRESTRICTED AREA BOUNDARY FOR LIQUID EFFLUENTS

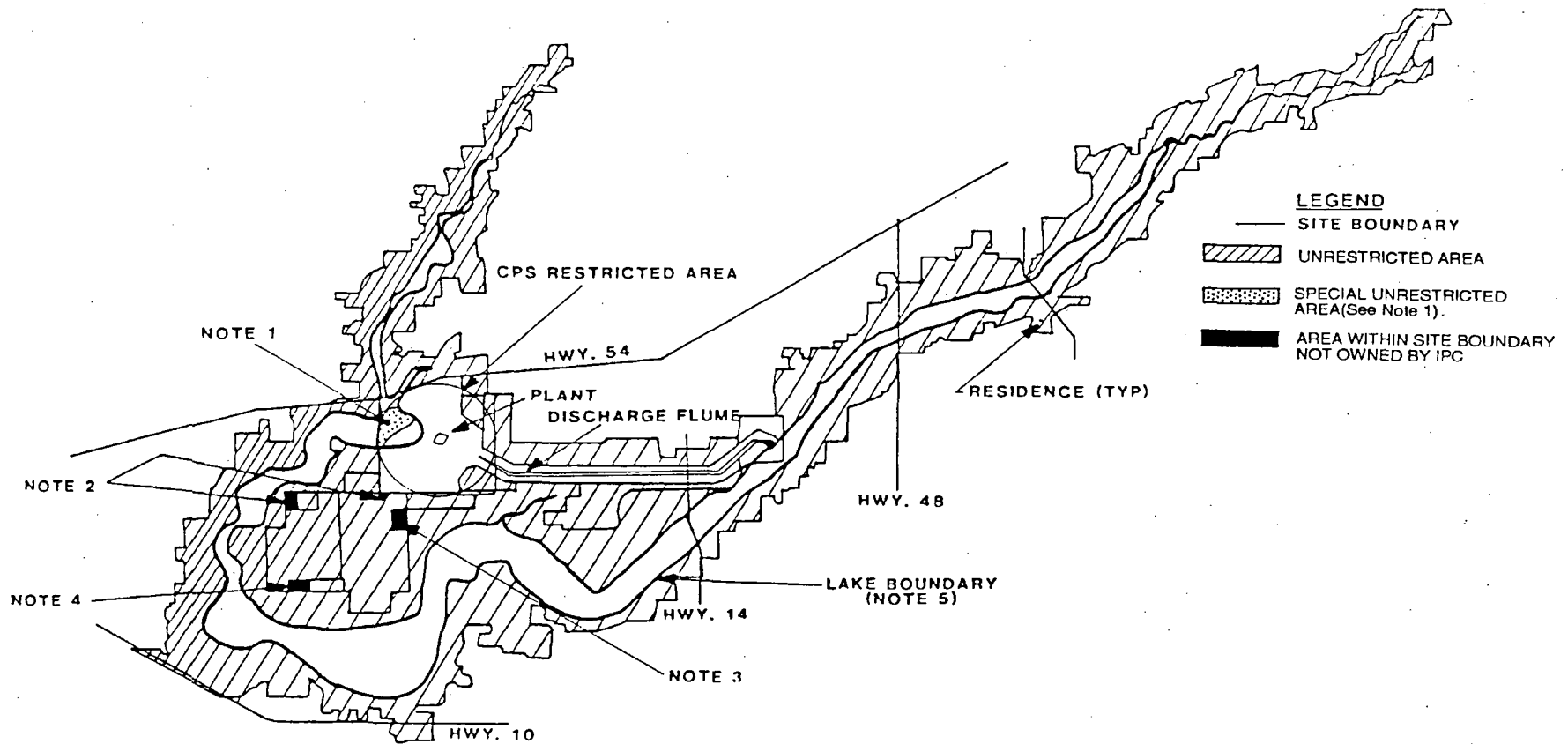

NOTES

1. THE AREA IN THE LAKE BETWEEN THE BUOYS AND THE EXCLUSION AREA BOUNDARY IS UNRESTRICTED AT THIS TIME. BUT WILL BE CONTROLLED IF PLANT EFFLUENT CONDITIONS WARRANT CLOSURE.
2. LAND PARCEL NOT OWNED BY AMERGEN, INCLUDES RESIDENCES.
3. LAND PARCEL NOT OWNED BY AMERGEN, OIL COMPANY PIPELINE PUMPING STATION.
4. LAND PARCEL NOT OWNED BY AMERGEN, AGRICULTURAL USE.
5. THE LAKE SHORELINE IS APPROXIMATELY 690 FT. MSL ELEVATION LINE.

### 2.3.3 Plant Service Water Effluent PRM Setpoints

Plant service water effluent continuously releases to the Seal Well where it mixes with circulating water effluent (if present) prior to entering Lake Clinton via the 3.4 mile discharge flume. If the plant service water system is in service then radioactive effluent monitoring is required. To ensure that Plant Service Water intersystem leakage has not occurred, weekly Service Water effluent grab samples will be obtained (when in service) and analyzed to determine the identity and quantity of principal gamma-emitting radionuclides. In addition, a quarterly composite of positive grab samples will be analyzed to determine the quantity of H-3, Sr-89, Sr-90, Fe-55 and gross alpha species released. The analytical Lower Limit of Detection (LLD) for these analyses are specified in Table 2.3-1.

If the weekly grab sample analysis indicates the presence of contamination above background, PRM setpoints will be established following section 2.3.2 methodology as follows:

- 2.3.3.1 Perform section 2.3.2.2, solving equation (3) for DF using the appropriate values in the concentration term from the grab sample analysis.
- 2.3.3.2 A modified dilution factor,  $DF_m$ , must be determined so that available dilution flows may be apportioned among simultaneous discharge pathways. The modified dilution factor is defined as:

$$DF_m = DF/F_A \quad (7)$$

where  $F_A$  is an administrative allocation factor which may be assigned any value between 0 and 1 under the condition that

$$\sum_n (F_A)_n \leq 1 \quad (8)$$

and where  $n$  = the number of liquid discharge pathways for which  $DF \geq 1$  and which are planned for simultaneous release. For simplicity,  $F_A$  may be assigned the value  $1/n$ . Calculate  $R_{cwm\max}$  in equation (4) by substituting the value of  $DF_m$  for  $D_{req}$  and perform the calculation specified in section 2.3.2.4 to determine flow rate and PRM setpoints.

#### 2.3.4 Shutdown Service Water (SX) Effluent PRM Setpoints

Shutdown Service Water, when initiated, is a potential continuous radioactive discharge pathway to the Ultimate Heat Sink (UHS) (see Figure 2.5-2). SX effluent sampling, analysis and setpoint establishment will be performed as discussed for the Plant Service Water system in Section 2.3.3.

#### 2.3.5 Fuel Pool Heat Exchanger Service Water Effluent PRM Setpoints

The Fuel Pool Heat Exchanger Service Water is normally supplied by the Component Cooling Water (CCW) system (a closed loop system). The Component Cooling Water system rejects heat loads to the Plant Service Water system where radiation from intersystem leakage would be detected as described in section 2.3.3. Fuel Pool Heat Exchanger Service Water cooling may also be provided from the Safe Shutdown Service Water System (SX) which is not a closed system. Effluent from the SX system is considered a potential radioactive discharge pathway when SX replaces Component Cooling Water as the heat sink for the Fuel Pool heat exchangers. Samples are collected from the Component Cooling Water system on a weekly basis and analyzed as discussed in section 2.3.3. This sample allows Component Cooling Water to be analyzed prior to placing the Fuel Pool Heat Exchanger in the SX cooling mode. This will account for a potential radioactive release to the Ultimate Heat Sink via SX. Discharge monitoring is performed any time a Fuel Pool Cooling heat exchanger is in service (FC water is flowing through the heat exchanger) **AND** the heat sink for the FC heat exchanger is being provided by SX. The analysis results may then be used to establish Fuel Pool Heat Exchanger Service Water PRM and flow rate setpoints following Section 2.3.3.1 and 2.3.3.2 methodology.

Any releases of radioactivity to the environment from the Plant Service Water (except during liquid radwaste discharges), Shutdown Service Water or Fuel Pool Heat Exchanger Service Water Systems are considered abnormal events. Such events will be accounted for as unplanned releases in the RADIOACTIVE EFFLUENT RELEASE REPORT.

#### 2.3.6 Component Cooling Water PRM Setpoints

The Component Cooling water system is a potential continuous radioactive discharge pathway to the Service Water system due to the Component Cooling water system generally operating at a higher pressure and the potential for heat exchanger tube leaks. Component Cooling provides cooling to components and heat exchangers that carry radioactive fluids or are in areas that could result in radioactive contamination if the components are damaged. Except for the sampling requirement described in 2.3.5, sampling on this system is done on an as needed basis. The PRM setpoints are established using the methodology in Section 2.3.3.

2.4 10CFR50, Appendix I Dose Limits

The Operation and Surveillance Requirements concerning 10CFR50, Appendix I Release Limits are specified in section 2.4.1. Dose calculations for ensuring compliance with these limits are discussed in section 2.4.2.

2.4.1 10CFR50, Appendix I Dose Limits - Operation and Surveillance Requirements

OPERATION REQUIREMENT

---

The dose or dose commitment to a MEMBER OF THE PUBLIC from radioactive materials in liquid effluents released to UNRESTRICTED AREAS (see Figure 2.1-1) shall be limited:

- a. During any calendar quarter to less than or equal to 1.5 mrem to the total body and to less than or equal to 5 mrem to any organ, and
- b. During any calendar year to less than or equal to 3 mrem to the total body and to less than or equal to 10 mrem to any organ.

This requirement applies at all times.

REMEDIAL REQUIREMENT:

With the calculated dose from the release of radioactive materials in liquid effluents exceeding any of the above limits, prepare and submit to the Regional Administrator of the Regional Office of the NRC within 30 days a Special Report that identifies the cause(s) for exceeding the limit(s) and defines the corrective actions that have been taken to reduce the releases and the proposed corrective actions to be taken to assure that subsequent releases will be in compliance with the above limits.

SURVEILLANCE REQUIREMENTS

---

- 2.4.1.1 Cumulative dose contributions from liquid effluents for the current calendar quarter and the current calendar year shall be determined in accordance with the methodology and parameters described in Section 2.4.2 at least once per 31 days.



2.4.2 Discussion

2.4.2.1 The dose contribution to the maximum exposed individual from all radionuclides identified in liquid effluents released to the unrestricted area is calculated as follows:

$$D_j = A_{ij} \sum \Delta t_s * C_{is} * F_{sr}, \text{ mrem} \quad (9)$$

where

$D_j$  = The cumulative calendar quarter or yearly dose to any organ  $j$  from liquid effluent for the total release period, mrem

$\Delta t_s$  = The length of time  $s$  over which  $C_{is}$  and  $F_{sr}$  are averaged for liquid releases, hours

= Liquid Radwaste Tank Volume/Liquid Radwaste Discharge Flow Rate

$C_{is}$  = The average concentration of nuclide  $i$  for time period  $s$  in undiluted liquid effluent during release period  $\Delta t_s$  for any liquid release,  $\mu$  Ci/ml

$F_{sr}$  = The near field average dilution factor for receptor  $r$  during any liquid effluent release, dimensionless. Defined as the ratio of the average undiluted liquid radwaste flow during the release, to the product of the average flow from the discharge structure (during the reporting period, i.e., quarter or year) to the unrestricted receiving water and  $Z$

$$= \frac{\text{Average Undiluted Liquid Waste Flow}}{(\text{Average Discharge Structure Flow})Z} \quad (10)$$

$Z$  = The applicable dilution factor for Lake Clinton, dimensionless

$$= 1.0$$

$$A_{ij} = \text{The composite ingestion dose commitment factor for the total body or critical organ } j \text{ of an ADULT for radionuclide } i, \text{ mrem/hr per } \mu\text{Ci/ml}$$

$$= K_o[(U_w/D_w) + (U_f BF_i)]DF_i \quad (11)$$

where

- $K_o$  = A units conversion factor,  $1.14E+05$  pCi-ml-yr/ $\mu$ Ci-liter-hr
- $$= (1.00E+06 \text{ pCi}/\mu\text{Ci})(1.00E+03 \text{ ml/liter})/8760 \text{ hr/yr}$$
- $U_w$  = Annual water consumption by the maximum adult, 0 liter/yr
- $D_w$  = Dilution factor from the near field area to the nearest potable water intake, 1.0
- $U_f$  = Adult fish consumption rate, 21 kg/yr (Table E-5 of Regulatory Guide 1.109)
- $BF_i$  = Bioaccumulation factor for radionuclide  $i$  in fish, pCi/kg per pCi/liter (Table 2.4-2 taken from Table A-1 of Regulatory Guide 1.109)
- $DF_i$  = Adult ingestion dose conversion factor for radionuclide  $i$ , total body or critical organ, mrem/pCi (Table 2.4-3 taken from Table E-11 of Regulatory Guide 1.109)

Table 2.4-1 contains values for  $A_{ij}$  as calculated by equation (11).

The quarterly limits specified in the OPERATION REQUIREMENT at the beginning of this section represent one-half of the annual design objective of Section II.A of 10CFR50, Appendix I.

TABLE 2.4-1

ADULT INGESTION DOSE COMMITMENT FACTORS -  $A_{ij}$   
(mrem/hr per  $\mu\text{Ci/ml}$ )

ISOTOPE	BONE	LIVER	T.BODY	THYROID	KIDNEY	LUNG	GI-LLI
H-3	NO DATA	2.26E-01	2.26E-01	2.26E-01	2.26E-01	2.26E-01	2.26E-01
C-14	3.12E+04*	6.24E+03	6.24E+03	6.24E+03	6.24E+03	6.24E+03	6.24E+03
NA-24	4.06E+02	4.06E+02	4.06E+02	4.06E+02	4.06E+02	4.06E+02	4.06E+02
P-32	1.39E+06	8.62E+04	5.36E+04	NO DATA	NO DATA	NO DATA	1.56E+05
CR-51	NO DATA	NO DATA	1.27E+00	7.60E-01	2.80E-01	1.68E+00	3.20E+02
MN-54	NO DATA	4.37E+03	8.34E+02	NO DATA	1.30E+03	NO DATA	1.34E+04
MN-56	NO DATA	1.10E+02	1.95E+01	NO DATA	1.40E+02	NO DATA	3.51E+03
FE-55	6.57E+02	4.54E+02	1.06E+02	NO DATA	NO DATA	2.53E+02	2.60E+02
FE-59	1.04E+03	2.44E+03	9.34E+02	NO DATA	NO DATA	6.81E+02	8.13E+03
CO-58	NO DATA	8.90E+01	2.00E+02	NO DATA	NO DATA	NO DATA	1.80E+03
CO-60	NO DATA	2.56E+02	5.64E+02	NO DATA	NO DATA	NO DATA	4.80E+03
NI-63	3.11E+04	2.15E+03	1.04E+03	NO DATA	NO DATA	NO DATA	4.49E+02
NI-65	1.26E+02	1.64E+01	7.48E+00	NO DATA	NO DATA	NO DATA	4.16E+02
CU-64	NO DATA	9.97E+00	4.67E+00	NO DATA	2.51E+01	NO DATA	8.48E+02
ZN-65	2.31E+04	7.36E+04	3.33E+04	NO DATA	4.92E+04	NO DATA	4.64E+04
ZN-69	4.92E+01	9.42E+01	6.55E+00	NO DATA	6.12E+01	NO DATA	1.41E+01
BR-83	NO DATA	NO DATA	4.03E+01	NO DATA	NO DATA	NO DATA	5.81E+01
BR-84	NO DATA	NO DATA	5.23E+01	NO DATA	NO DATA	NO DATA	4.10E-04
BR-85	NO DATA	NO DATA	2.15E+00	NO DATA	NO DATA	NO DATA	LT 1E-15**
RB-86	NO DATA	1.01E+05	4.70E+04	NO DATA	NO DATA	NO DATA	1.99E+04
RB-88	NO DATA	2.89E+02	1.53E+02	NO DATA	NO DATA	NO DATA	4.00E-09
RB-89	NO DATA	1.92E+02	1.35E+02	NO DATA	NO DATA	NO DATA	1.11E-11
SR-89	2.21E+04	NO DATA	6.34E+02	NO DATA	NO DATA	NO DATA	3.54E+03
SR-90	5.43E+05	NO DATA	1.33E+05	NO DATA	NO DATA	NO DATA	1.57E+04
SR-91	4.06E+02	NO DATA	1.64E+01	NO DATA	NO DATA	NO DATA	1.94E+03
SR-92	1.54E+02	NO DATA	6.67E+00	NO DATA	NO DATA	NO DATA	3.05E+03
Y-90	5.75E-01	NO DATA	1.54E-02	NO DATA	NO DATA	NO DATA	6.10E+03
Y-91m	5.43E-03	NO DATA	2.10E-04	NO DATA	NO DATA	NO DATA	1.60E-02
Y-91	8.42E+00	NO DATA	2.25E-01	NO DATA	NO DATA	NO DATA	4.64E+03
Y-92	5.05E-02	NO DATA	1.48E-03	NO DATA	NO DATA	NO DATA	8.84E+02
Y-93	1.60E-01	NO DATA	4.42E-03	NO DATA	NO DATA	NO DATA	5.08E+03
ZR-95	2.40E-01	7.69E-02	5.20E-02	NO DATA	1.21E-01	NO DATA	2.44E+02
ZR-97	1.32E-02	2.67E-03	1.22E-03	NO DATA	4.04E-03	NO DATA	8.28E+02
NB-95	4.46E+02	2.48E+02	1.33E+02	NO DATA	2.45E+02	NO DATA	1.51E+06
MO-99	NO DATA	1.03E+02	1.96E+01	NO DATA	2.33E+02	NO DATA	2.39E+02
TC-99m	8.86E-03	2.50E-02	3.19E-01	NO DATA	3.80E-01	1.23E-02	1.48E+01
TC-101	9.11E-03	1.31E-02	1.29E-01	NO DATA	2.36E-01	6.70E-03	3.94E-14
RU-103	4.42E+00	NO DATA	1.90E+00	NO DATA	1.69E+01	NO DATA	5.16E+02
RU-105	3.68E-01	NO DATA	1.45E-01	NO DATA	4.76E+00	NO DATA	2.25E+02
RU-106	6.57E+01	NO DATA	8.32E+00	NO DATA	1.27E+02	NO DATA	4.25E+03
AG-110m	NO DATA	NO DATA	NO DATA	NO DATA	NO DATA	NO DATA	NO DATA
TE-125m	2.57E+03	9.28E+02	3.43E+02	7.70E+02	1.04E+04	NO DATA	1.02E+04
TE-127m	6.47E+03	2.31E+03	7.89E+02	1.65E+03	2.63E+04	NO DATA	2.17E+04
TE-127	1.05E+02	3.77E+01	2.28E+01	7.79E+01	4.28E+02	NO DATA	8.30E+03
TE-129m	1.10E+04	4.10E+03	1.74E+03	3.78E+03	4.59E+04	NO DATA	5.54E+04
TE-129	3.00E+01	1.13E+01	7.31E+00	2.30E+01	1.26E+02	NO DATA	2.26E+01
TE-131m	1.65E+03	8.09E+02	6.74E+02	1.28E+03	8.19E+03	NO DATA	8.03E+04
TE-131	1.88E+01	7.87E+00	5.95E+00	1.55E+01	8.25E+01	NO DATA	2.67E+00

TABLE 2.4-1 (cont'd)

 ADULT INGESTION DOSE COMMITMENT FACTORS -  $A_{ij}$   
 (mrem/hr per  $\mu\text{Ci/ml}$ )

ISOTOPE	BONE	LIVER	T.BODY	THYROID	KIDNEY	LUNG	GI-LLI
TE-132	2.41E+03	1.56E+03	1.46E+03	1.72E+03	1.50E+04	NO DATA	7.37E+04
I-130	2.71E+01	7.99E+01	3.15E+01	6.78E+03	1.25E+02	NO DATA	6.88E+01
I-131	1.49E+02	2.13E+02	1.22E+02	6.99E+04	3.66E+02	NO DATA	5.63E+01
I-132	7.28E+00	1.95E+01	6.81E+00	6.81E+02	3.10E+01	NO DATA	3.66E+00
I-133	5.09E+01	8.85E+01	2.70E+01	1.30E+04	1.54E+02	NO DATA	7.96E+01
I-134	3.80E+00	1.03E+01	3.69E+00	1.79E+02	1.64E+01	NO DATA	9.00E-03
I-135	1.59E+01	4.16E+01	1.53E+01	2.74E+03	6.67E+01	NO DATA	4.70E+01
CS-134	2.97E+05	7.07E+05	5.78E+05	NO DATA	2.29E+05	7.60E+04	1.24E+04
CS-136	3.11E+04	1.23E+05	8.84E+04	NO DATA	6.84E+04	9.37E+03	1.40E+04
CS-137	3.81E+05	5.21E+05	3.41E+05	NO DATA	1.77E+05	5.88E+04	1.01E+04
CS-138	2.64E+02	5.21E+02	2.58E+02	NO DATA	3.83E+02	3.78E+01	2.22E-03
BA-139	9.29E-01	6.60E-04	2.72E-02	NO DATA	6.18E-04	3.75E-04	1.65E+00
BA-140	1.94E+02	2.44E-01	1.27E+01	NO DATA	8.29E-02	1.40E-01	4.00E+02
BA-141	4.50E-01	3.40E-04	1.52E-02	NO DATA	3.16E-04	1.93E-04	2.12E-10
BA-142	2.04E-01	2.09E-04	1.28E-02	NO DATA	1.77E-04	1.18E-04	2.89E-19
LA-140	1.49E-01	7.53E-02	1.99E-02	NO DATA	NO DATA	NO DATA	5.53E+03
LA-142	7.65E-03	3.48E-03	8.66E-04	NO DATA	NO DATA	NO DATA	2.54E+01
CE-141	2.24E-02	1.51E-02	1.72E-03	NO DATA	7.03E-03	NO DATA	5.78E+01
CE-143	3.94E-03	2.92E+00	3.23E-04	NO DATA	1.28E-03	NO DATA	1.09E+02
CE-144	1.17E+00	4.88E-01	6.26E-02	NO DATA	2.89E-01	NO DATA	3.94E+02
PR-143	5.50E-01	2.20E-01	2.72E-02	NO DATA	1.27E-01	NO DATA	2.41E+03
PR-144	1.80E-03	7.47E-04	9.14E-05	NO DATA	4.21E-04	NO DATA	2.59E-10
ND-147	3.76E-01	4.34E-01	2.60E-02	NO DATA	2.54E-01	NO DATA	2.08E+03
W-187	2.95E+02	2.47E+02	8.63E+01	NO DATA	NO DATA	NO DATA	8.09E+04
NP-239	2.84E-02	2.80E-03	1.54E-03	NO DATA	8.72E-03	NO DATA	5.74E+02

\*3.12E+04

\*\*Less than 1.00E-15

TABLE 2.4-2

BIOACCUMULATION FACTORS -BF<sub>i</sub>  
 (pCi/kg per pCi/liter)

<u>ELEMENT</u>	<u>FRESHWATER FISH</u>
H	9.00E-01
C	4.60E+03
Na	1.00E+02
P	1.00E+05
Cr	2.00E+02
Mn	4.00E+02
Fe	1.00E+02
Co	5.00E+01
Ni	1.00E+02
Cu	5.00E+01
Zn	2.00E+03
Br	4.20E+02
Rb	2.00E+03
Sr	3.00E+01
Y	2.50E+01
Zr	3.30E+00
Nb	3.00E+04
Mo	1.00E+01
Tc	1.50E+01
Ru	1.00E+01
Rh	1.00E+01
Te	4.00E+02
I	1.50E+01
Cs	2.00E+03
Ba	4.00E+00
La	2.50E+01
Ce	1.00E+00
Pr	2.50E+01
Nd	2.50E+01
W	1.20E+03
Np	1.00E+01

TABLE 2.4-3

ADULT INGESTION DOSE FACTORS -DF<sub>i</sub>  
(mrem/pCi ingested)

ISOTOPE	BONE	LIVER	T.BODY	THYROID	KIDNEY	LUNG	GI-LLI
H-3	NO DATA	1.05E-07	1.05E-07	1.05E-07	1.05E-07	1.05E-07	1.05E-07
C-14	2.84E-06*	5.68E-07	5.68E-07	5.68E-07	5.68E-07	5.68E-07	5.68E-07
NA-24	1.70E-06	1.70E-06	1.70E-06	1.70E-06	1.70E-06	1.70E-06	1.70E-06
P-32	1.93E-04	1.20E-05	7.46E-06	NO DATA	NO DATA	NO DATA	2.17E-05
CR-51	NO DATA	NO DATA	2.66E-09	1.59E-09	5.86E-10	3.53E-09	6.69E-07
MN-54	NO DATA	4.57E-06	8.72E-07	NO DATA	1.36E-06	NO DATA	1.40E-05
MN-56	NO DATA	1.15E-07	2.04E-08	NO DATA	1.46E-07	NO DATA	3.67E-06
FE-55	2.75E-06	1.90E-06	4.43E-07	NO DATA	NO DATA	1.06E-06	1.09E-06
FE-59	4.34E-06	1.02E-05	3.91E-06	NO DATA	NO DATA	2.85E-06	3.40E-05
CO-58	NO DATA	7.45E-07	1.67E-06	NO DATA	NO DATA	NO DATA	1.51E-05
CO-60	NO DATA	2.14E-06	4.72E-06	NO DATA	NO DATA	NO DATA	4.02E-05
NI-63	1.30E-04	9.01E-06	4.36E-06	NO DATA	NO DATA	NO DATA	1.88E-06
NI-65	5.28E-07	6.86E-08	3.13E-08	NO DATA	NO DATA	NO DATA	1.74E-06
CU-64	NO DATA	8.33E-08	3.91E-08	NO DATA	2.10E-07	NO DATA	7.10E-06
ZN-65	4.84E-06	1.54E-05	6.96E-06	NO DATA	1.03E-05	NO DATA	9.70E-06
ZN-69	1.03E-08	1.97E-08	1.37E-09	NO DATA	1.28E-08	NO DATA	2.96E-09
BR-83	NO DATA	NO DATA	4.02E-08	NO DATA	NO DATA	NO DATA	5.79E-08
BR-84	NO DATA	NO DATA	5.21E-08	NO DATA	NO DATA	NO DATA	4.09E-13
BR-85	NO DATA	NO DATA	2.14E-09	NO DATA	NO DATA	NO DATA	LT 1E-24**
RB-86	NO DATA	2.11E-05	9.83E-06	NO DATA	NO DATA	NO DATA	4.16E-06
RB-88	NO DATA	6.05E-08	3.21E-08	NO DATA	NO DATA	NO DATA	8.36E-19
RB-89	NO DATA	4.01E-08	2.82E-08	NO DATA	NO DATA	NO DATA	2.33E-21
SR-89	3.08E-04	NO DATA	8.84E-06	NO DATA	NO DATA	NO DATA	4.94E-05
SR-90	7.58E-03	NO DATA	1.86E-03	NO DATA	NO DATA	NO DATA	2.19E-04
SR-91	5.67E-06	NO DATA	2.29E-07	NO DATA	NO DATA	NO DATA	2.70E-05
SR-92	2.15E-06	NO DATA	9.30E-08	NO DATA	NO DATA	NO DATA	4.26E-05
Y-90	9.62E-09	NO DATA	2.58E-10	NO DATA	NO DATA	NO DATA	1.02E-04
Y-91m	9.09E-11	NO DATA	3.52E-12	NO DATA	NO DATA	NO DATA	2.67E-10
Y-91	1.41E-07	NO DATA	3.77E-09	NO DATA	NO DATA	NO DATA	7.76E-05
Y-92	8.45E-10	NO DATA	2.47E-11	NO DATA	NO DATA	NO DATA	1.48E-05
Y-93	2.68E-09	NO DATA	7.40E-11	NO DATA	NO DATA	NO DATA	8.50E-05
ZR-95	3.04E-08	9.75E-09	6.60E-09	NO DATA	1.53E-08	NO DATA	3.09E-05
ZR-97	1.68E-09	3.39E-10	1.55E-10	NO DATA	5.12E-10	NO DATA	1.05E-04
NB-95	6.22E-09	3.46E-09	1.86E-09	NO DATA	3.42E-09	NO DATA	2.10E-05
MO-99	NO DATA	4.31E-06	8.20E-07	NO DATA	9.76E-06	NO DATA	9.99E-06
TC-99m	2.47E-10	6.98E-10	8.89E-09	NO DATA	1.06E-08	3.42E-10	4.13E-07
TC-101	2.54E-10	3.66E-10	3.59E-09	NO DATA	6.59E-09	1.87E-10	1.10E-21
RU-103	1.85E-07	NO DATA	7.97E-08	NO DATA	7.06E-07	NO DATA	2.16E-05
RU-105	1.54E-08	NO DATA	6.08E-09	NO DATA	1.99E-07	NO DATA	9.42E-06
RU-106	2.75E-06	NO DATA	3.48E-07	NO DATA	5.31E-06	NO DATA	1.78E-04
AG-110m	1.60E-07	1.48E-07	8.79E-08	NO DATA	2.91E-07	NO DATA	6.04E-05
TE-125m	2.68E-06	9.71E-07	3.59E-07	8.06E-07	1.09E-05	NO DATA	1.07E-05
TE-127m	6.77E-06	2.42E-06	8.25E-07	1.73E-06	2.75E-05	NO DATA	2.27E-05
TE-127	1.10E-07	3.95E-08	2.38E-08	8.15E-08	4.48E-07	NO DATA	8.68E-06
TE-129m	1.15E-05	4.29E-06	1.82E-06	3.95E-06	4.80E-05	NO DATA	5.79E-05
TE-129	3.14E-08	1.18E-08	7.65E-09	2.41E-08	1.32E-07	NO DATA	2.37E-08
TE-131m	1.73E-06	8.46E-07	7.05E-07	1.34E-06	8.57E-06	NO DATA	8.40E-05
TE-131	1.97E-08	8.23E-09	6.22E-09	1.62E-08	8.63E-08	NO DATA	2.79E-09

TABLE 2.4-3 (cont'd)

ADULT INGESTION DOSE FACTORS - DF<sub>i</sub>  
(mrem/pCi ingested)

ISOTOPE	BONE	LIVER	T.BODY	THYROID	KIDNEY	LUNG	GI-LLI
TE-132	2.52E-06	1.63E-06	1.53E-06	1.80E-06	1.57E-05	NO DATA	7.71E-05
I-130	7.56E-07	2.23E-06	8.80E-07	1.89E-04	3.48E-06	NO DATA	1.92E-06
I-131	4.16E-06	5.95E-06	3.41E-06	1.95E-03	1.02E-05	NO DATA	1.57E-06
I-132	2.03E-07	5.43E-07	1.90E-07	1.90E-05	8.65E-07	NO DATA	1.02E-07
I-133	1.42E-06	2.47E-06	7.53E-07	3.63E-04	4.31E-06	NO DATA	2.22E-06
I-134	1.06E-07	2.88E-07	1.03E-07	4.99E-06	4.58E-07	NO DATA	2.51E-10
I-135	4.43E-07	1.16E-06	4.28E-07	7.65E-05	1.86E-06	NO DATA	1.31E-06
CS-134	6.22E-05	1.48E-04	1.21E-04	NO DATA	4.79E-05	1.59E-05	2.59E-06
CS-136	6.51E-06	2.57E-05	1.85E-05	NO DATA	1.43E-05	1.96E-06	2.92E-06
CS-137	7.97E-05	1.09E-04	7.14E-05	NO DATA	3.70E-05	1.23E-05	2.11E-06
CS-138	5.52E-08	1.09E-07	5.40E-08	NO DATA	8.01E-08	7.91E-09	4.65E-13
BA-139	9.70E-08	6.91E-11	2.84E-09	NO DATA	6.46E-11	3.92E-11	1.72E-07
BA-140	2.03E-05	2.55E-08	1.33E-06	NO DATA	8.67E-09	1.46E-08	4.18E-05
BA-141	4.71E-08	3.56E-11	1.59E-09	NO DATA	3.31E-11	2.02E-11	2.22E-17
BA-142	2.13E-08	2.19E-11	1.34E-09	NO DATA	1.85E-11	1.24E-11	3.00E-26
LA-140	2.50E-09	1.26E-09	3.33E-10	NO DATA	NO DATA	NO DATA	9.25E-05
LA-142	1.28E-10	5.82E-11	1.45E-11	NO DATA	NO DATA	NO DATA	4.25E-07
CE-141	9.36E-09	6.33E-09	7.18E-10	NO DATA	2.94E-09	NO DATA	2.42E-05
CE-143	1.65E-09	1.22E-06	1.35E-10	NO DATA	5.37E-10	NO DATA	4.56E-05
CE-144	4.88E-07	2.04E-07	2.62E-08	NO DATA	1.21E-07	NO DATA	1.65E-04
PR-143	9.20E-09	3.69E-09	4.56E-10	NO DATA	2.13E-09	NO DATA	4.03E-05
PR-144	3.01E-11	1.25E-11	1.53E-12	NO DATA	7.05E-12	NO DATA	4.33E-18
ND-147	6.29E-09	7.27E-09	4.35E-10	NO DATA	4.25E-09	NO DATA	3.49E-05
W-187	1.03E-07	8.61E-08	3.01E-08	NO DATA	NO DATA	NO DATA	2.82E-05
NP-239	1.19E-09	1.17E-10	6.45E-11	NO DATA	3.65E-10	NO DATA	2.40E-05

\*2.84E-06

\*\*Less than 1.00E-24

FIGURE 2.5-1

LIQUID RADWASTE TREATMENT SYSTEM

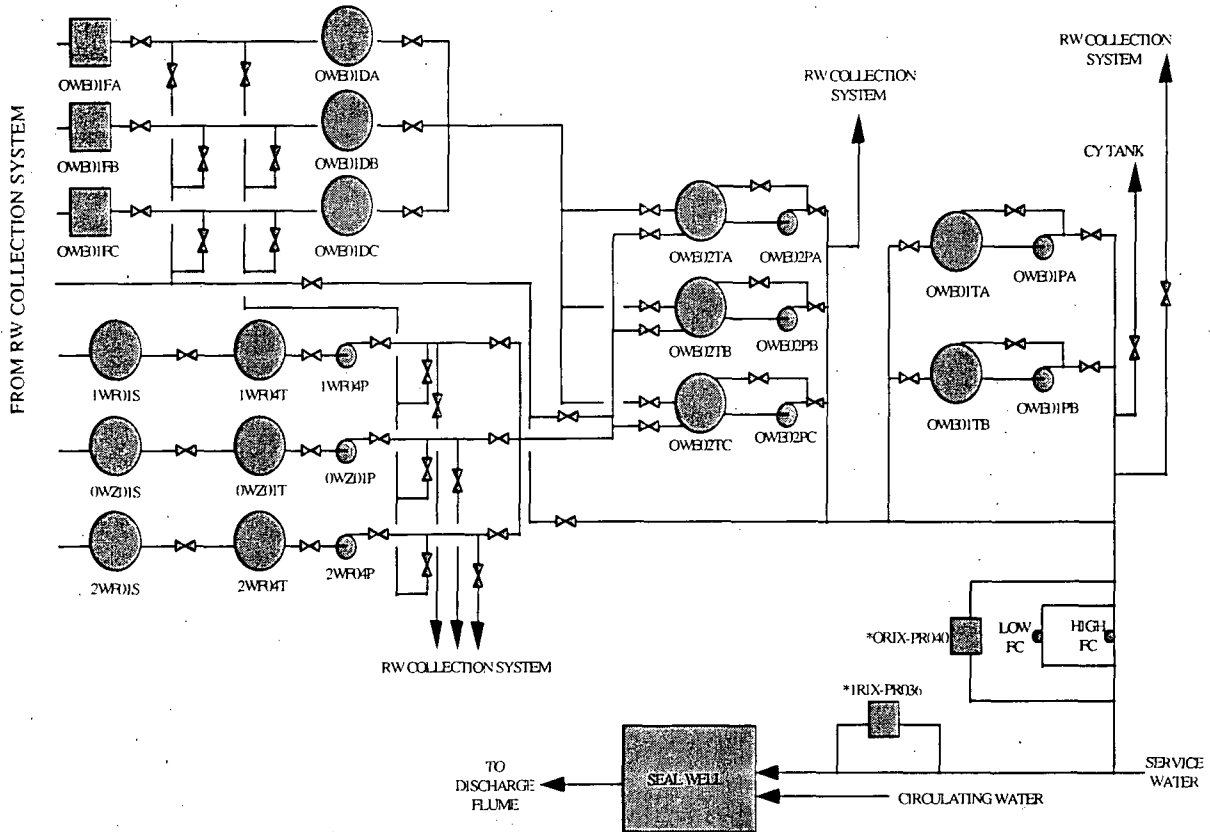

\*Monitors required by Section 2.7

WF01S Floor Drain Evaporator	OWZ01P Chem. Wst. Evap. Tank Pump	2WF04T Floor Drain Evaporator Tank	OWE02PA, B, and C Waste Samp. Tk Pumps
WF01S Floor Drain Evaporator	OWE01FA, B, and C Waste Filters	OWZ01T Chem. Waste Evaporator Tank	OWE01TA and B Excess Water Tanks
OWZ01S Chemical Waste Evaporator	OWE01DA, B, and C Waste Demins	1WF04P Flr. Drn. Evap. Tank Pump	OWE01PA and B Excess Water Tank Pumps
WF04T Floor Drain Evaporator Tank	OWE02TA, B, and C Waste Sample Tks.	2WF04P Flr. Drn. Evap. Tank Pump	1PR036 Service Water PRM
			OPR040 Liquid RW Discharge PRM



FIGURE 2.5-2

SHUTDOWN AND FUEL POOL HEAT EXCHANGER SERVICE WATER  
EFFLUENT MONITORS

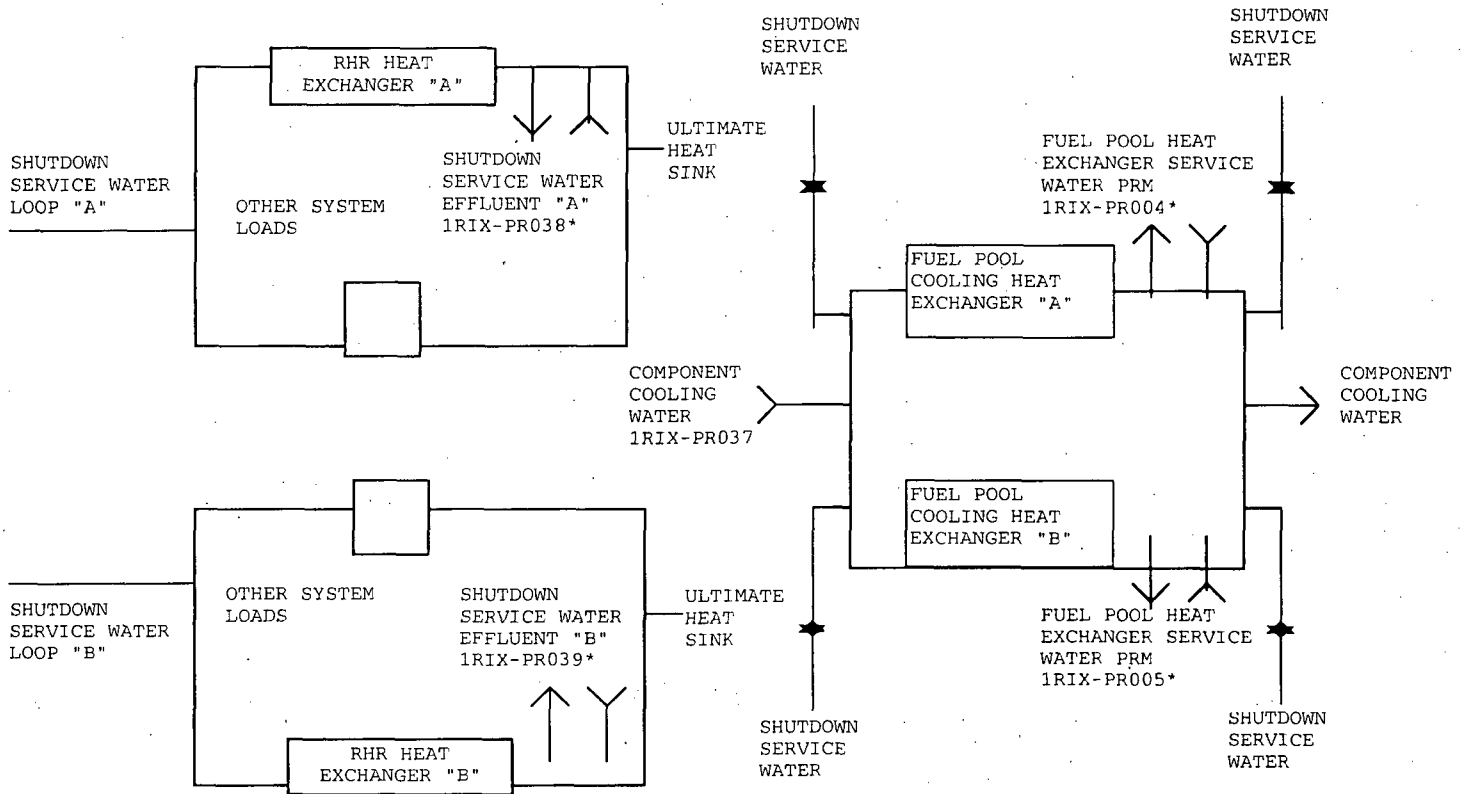

NORMAL COOLING SUPPLY - COMPONENT COOLING WATER  
EMERGENCY COOLING SUPPLY - SHUTDOWN SERVICE WATER

\*Monitors required by Section 2.7

1RIX-PR038 Shutdown Service  
Water Effluent "A"

1RIX-PR005 Fuel Pool Heat  
Exchanger Service Water PRM

1RIX-PR039 Shutdown Service  
Water Effluent "B"

1RIX-PR004 Fuel Pool Heat  
Exchanger Service Water PRM

1RIX-PR037 Component Cooling  
Water

FIGURE 2.5-3

SOLID RADWASTE SYSTEM  
SIMPLIFIED FLOW DIAGRAM

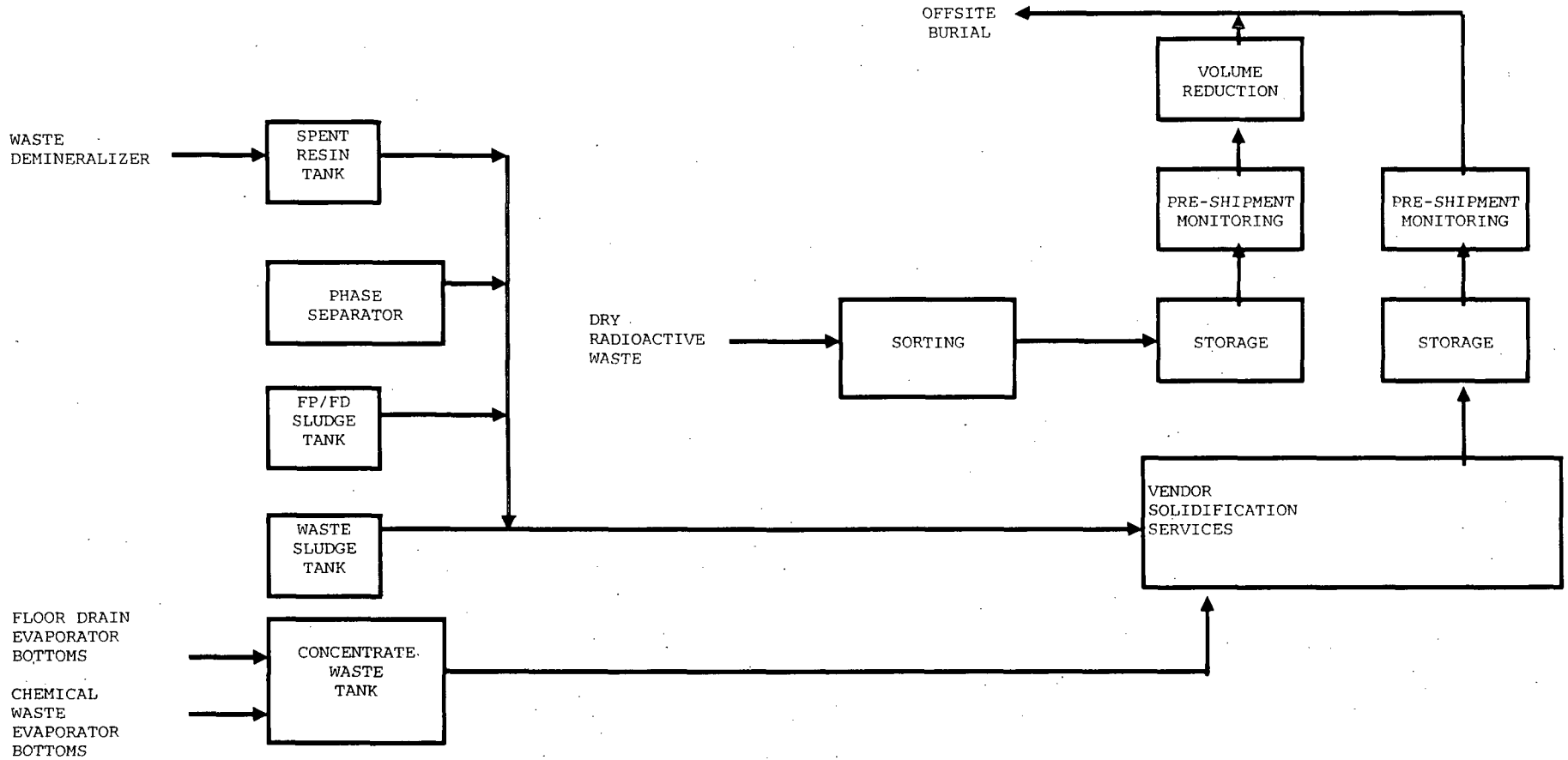

2.5 Liquid Radwaste Treatment System

2.5.1 Liquid Radwaste Treatment System - Operation and Surveillance Requirements

OPERATION REQUIREMENT

---

The liquid radwaste treatment system shall be OPERABLE. The appropriate portions of the system (Figure 2.5-1) shall be used to reduce the radioactive materials in liquid wastes prior to their discharge when the projected doses due to the liquid effluent to UNRESTRICTED AREAS (see Figure 2.1-1) would exceed 0.06 mrem to the total body or 0.2 mrem to any organ in a 31-day period. This requirement applies at all times.

REMEDIAL REQUIREMENT:

With radioactive liquid waste being discharged without treatment and in excess of the above limits and any portion of the liquid radwaste treatment system not in operation prepare and submit to the Regional Administrator of the Regional Office of the NRC within 30 days a Special Report that includes the following information:

1. Explanation of why liquid radwaste was being discharged without treatment, identification of any inoperable equipment or subsystems, and the reason for the inoperability.
2. Action(s) taken to restore the inoperable equipment to OPERABLE status, and
3. Summary description of action(s) taken to prevent a recurrence.

SURVEILLANCE REQUIREMENTS

- 2.5.1.1 Doses due to liquid releases to UNRESTRICTED AREAS shall be projected at least once per 31 days in accordance with the methodology and parameters described in equation 12.

Liquid Effluent Dose Projection Calculations

The 31 day projected dose shall be calculated using the following equation

$$D_{pj} = (D_j * p) + D_{aj} \quad (12)$$

where:

$D_{pj}$  = the 31 day projected dose by organ j.

$D_j$  = total dose (mrem) for all valid release points for the release period (usually quarter) by organ j.

$p$  = the projection factor which is the results of 31 divided by the number of days from the start of the quarter to the end of the release.

$D_{aj}$  = additional anticipated dose for gaseous release by organ j and quarter of release.

- 2.5.1.2 The liquid radwaste treatment shall be demonstrated OPERABLE by meeting the Operation Requirements of Section 2.3.1 and 2.4.1.

2.5.2 Temporary Liquid Radwaste Hold-Up Tanks

The use of temporary liquid radwaste hold-up tanks may occur at CPS. To comply with Operational Requirements Manual (ORM) 2.4.4, the curie limit for liquid radwaste stored in such tanks may be calculated using the methodology presented in Appendix B of NUREG-0133 (BWR-RATAFR code), but limited to less than or equal to 10 curies, excluding tritium and dissolved or entrained noble gases.

2.6 Doses From Other Significant Liquid Effluent Pathways

Section 2.4 of this manual is based upon the aquatic food and potable water exposure pathways only. Other exposure pathways, namely shoreline deposits and irrigated crops, may arise at Clinton Power Station and will be included in the section 2.4 dose contribution if they are likely to provide a significant contribution to the total dose. A pathway is considered significant if a conservative evaluation yields an additional dose increment greater than or equal to 10 percent of the total from all other existing pathways. Methods for calculating doses from other potentially significant liquid effluent pathways are presented in Appendix A to Regulatory Guide 1.109.

When the land use census or environmental monitoring information determine that other significant liquid effluent pathways are present, the Regulatory Guide 1.109 Appendix A equations and parameters will be used in lieu of site-specific data to determine a pathway's significance.

2.7 Radioactive Liquid Effluent Monitoring Instrumentation

2.7.1 Radioactive Liquid Effluent Monitoring Instrumentation -  
Operation and Surveillance Requirements

OPERATION REQUIREMENT

The radioactive liquid effluent monitoring instrumentation channels shown in Table 2.7-1 shall be OPERABLE with their alarm/trip setpoints set to ensure that the limits of Section 2.3.1 are not exceeded. The alarm/trip setpoints of these channels shall be determined and adjusted in accordance with the methodology and parameters described in Sections 2.3.2 through 2.3.5.

REMEDIAL REQUIREMENT:

- a. With a radioactive liquid effluent monitoring instrumentation channel alarm/trip setpoint less conservative than required by the above requirement, without delay suspend the release of radioactive liquid effluents monitored by the affected channel, or declare the channel inoperable and implement actions of requirement b below.
- b. With less than the minimum number of radioactive liquid effluent monitoring instrumentation channels OPERABLE, comply with the REMEDIAL REQUIREMENT shown in Table 2.7-1. Restore the inoperable instruments to OPERABLE status within 30 days and, if unsuccessful, explain in the next Radioactive Effluent Release Report why the inoperability was not corrected in a timely manner.

SURVEILLANCE REQUIREMENTS

- 2.7.1.1 Each radioactive liquid effluent monitoring instrumentation control shall be demonstrated OPERABLE by performance of the CHANNEL CHECK, SOURCE CHECK, CHANNEL CALIBRATION and CHANNEL FUNCTIONAL TEST at the frequencies shown in Table 2.7-2.

TABLE 2.7-1  
RADIOACTIVE LIQUID EFFLUENT MONITORING INSTRUMENTATION

	<u>MINIMUM CHANNELS OPERABLE (e)</u>	<u>REMEDIAL REQUIREMENT</u>	<u>APPLICABILITY</u>
1. RADIOACTIVE MONITORS PROVIDING ALARM AND AUTOMATIC TERMINATION OF RELEASE			
a. Liquid Radwaste Discharge Process Radiation Monitor (ORIX-PR040)	1(a)	1	(b)
2. RADIOACTIVITY MONITORS PROVIDING ALARM BUT NOT PROVIDING AUTOMATIC TERMINATION OF RELEASE			
a. Plant Service Water Effluent Process Radiation Monitor (1RIX-PR036)	1(a)	2	(c)
b. Shutdown Service Water Effluent Process Radiation Monitor (Div. 1: 1RIX-PR038 Div 2: 1RIX-PR039)	1/Division* (a)	2	(c)
c. Fuel Pool Heat Exchanger Service Water Radiation Monitor (Train A: 1RIX-PR004 Train B: 1RIX-PR005)	1/on service heat exchanger(a)	2	(c)
d. Component Cooling Water Process Radiation Monitor (1RIX-PR037)	1(a)	2	(c)
3. FLOW RATE MEASUREMENT DEVICES (OUIX-PR052)			
a. Liquid Radwaste Effluent Line (Channel 1-Low, Channel 2-High)	1	3	(b)
b. Plant Service Water Effluent Line (Channel 3)	1	3	(b)
c. Plant Circulation Water Line** (Channel 5)	1	3	(b)
4. TANK LEVEL INDICATING DEVICES			
a. Cycled Condensate Storage (Meter Indication at panel 1H13-P870)	1	4	(d)
b. Reactor Core Isolation Cooling Storage (Meter Indication at panel 1H13-P862)	1	4	(d)

\*Division I and Division II only.

\*\* The plant circulation water (CW) flow rate measurement device is based upon the CW pump breaker position and an analog signal that specifies a preset flow rate.

TABLE 2.7-1 (Continued)

RADIOACTIVE LIQUID EFFLUENT MONITORING INSTRUMENTATIONTABLE NOTATION

- (a) Channel OPERABILITY shall include the capability of the MCR ARPR LAN to provide the alarm status of the applicable radiation monitor channel(s).
- (b) Required only during radioactive discharge.
- (c) Any time system is in service.
- (d) During additions to the tank
- (e) When a channel is placed in an inoperable status solely for performance of required surveillances (source checks, sampling) entry into associated Remedial Requirements may be delayed for up to one hour.

REMEDIAL REQUIREMENT

REMEDIAL REQUIREMENT 1	<p>With the number of channels OPERABLE less than required by the Minimum Channels OPERABLE requirement, effluent releases may continue via this pathway provided that prior to initiating a release:</p> <p>a. At least two independent samples are analyzed in accordance with Section 2.3.1.1, and</p> <p>b. At least two technically qualified members independently verify the release rate calculations and discharge line valving:</p> <p>Otherwise, suspend release of radioactive effluents via this pathway.</p>
REMEDIAL REQUIREMENT 2	<p>a. If the communication link or the MCR ARPR LAN is inoperable perform CHANNEL CHECK using local monitor indication within 8 hours and at least once per 8 hours thereafter.</p> <p>b. With the monitor otherwise inoperable, effluent releases via this pathway may continue provided that at least once per 12 hours, grab samples are collected and analyzed for radioactivity at a Lower Limit of Detection of <math>\leq 5.00E-07</math> <math>\mu\text{Ci}/\text{ml}</math> for the Principal Gamma Emitters. The Principal Gamma Emitters are: Mn-54, Fe-59, Co-58, Co-60, Zn-65, Mo-99, Cs-134, Cs-137, and Ce-141. Ce-144 shall be measured with an LLD of <math>\leq 5.00E-06</math> <math>\mu\text{Ci}/\leq</math>. Dissolved and Entrained Gases (gamma emitters only) shall be measured with an LLD of <math>\leq 1.00E-05^{-5}</math> <math>\mu\text{Ci}/\text{ml}</math>. These Dissolved and Entrained Gases are: Xe-133, Xe-135, Xe-138, Kr-85m, Kr-87, and Kr-88.</p>

TABLE 2.7-1 (Continued)RADIOACTIVE LIQUID EFFLUENT MONITORING INSTRUMENTATIONTABLE NOTATION

REMEDIAL REQUIREMENT 3	With the number of channels OPERABLE less than required by the Minimum Channels OPERABLE requirement, effluent releases via this pathway may continue provided the flow rate is estimated at least once per 4 hours during actual releases. Pump performance curves generated in place may be used to estimate flow. CW flow may also be estimated from the number of CW pumps in operation. All flows diverted from Plant Service Water must be taken into account when estimating dilution flow when Plant Service Water is the only dilution source.
REMEDIAL REQUIREMENT 4	With the number of channels OPERABLE less than required by the Minimum Channels OPERABLE requirement, liquid additions to this tank may continue provided the tank liquid level is estimated during all liquid additions to the tank.



TABLE 2.7-2RADIOACTIVE LIQUID EFFLUENT MONITORING INSTRUMENTATION SURVEILLANCE REQUIREMENTS

<u>INSTRUMENT</u>	<u>CHANNEL CHECK</u>	<u>SOURCE CHECK</u>	<u>CHANNEL CALIBRATION</u>	<u>CHANNEL FUNCTIONAL TEST</u>
1. RADIOACTIVITY MONITORS PROVIDING ALARM AND AUTOMATIC TERMINATION OF RELEASE				
a. Liquid Radwaste Discharge Process Radiation Monitor Effluent Line	S <sup>(4,5)</sup>	P	R(3)	Q(1)
2. RADIOACTIVITY MONITORS PROVIDING ALARM BUT NOT PROVIDING AUTOMATIC TERMINATION OF RELEASE				
a. Plant Service Water Effluent Process Radiation Monitor	S <sup>(5)</sup>	M	R(3)	Q(2)
b. Shutdown Service Water Effluent Process Radiation Monitor	S <sup>(5)</sup>	M	R(3)	Q(2)
c. Fuel Pool Heat Exchanger Service Water Radiation Monitor	S <sup>(5)</sup>	M	R(3)	Q(2)
d. Component Cooling Water Process Radiation Monitor	S <sup>(5)</sup>	M	R(3)	Q(2)

TABLE 2.7-2 (Continued)

RADIOACTIVE LIQUID EFFLUENT MONITORING INSTRUMENTATION SURVEILLANCE REQUIREMENTS

<u>INSTRUMENT</u>	<u>CHANNEL CHECK</u>	<u>SOURCE CHECK</u>	<u>CHANNEL CALIBRATION</u>	<u>CHANNEL FUNCTIONAL TEST</u>
3. FLOW RATE MEASUREMENT DEVICES				
a. Liquid Radwaste Effluent Line	S <sup>(4)</sup>	NA	R	Q
b. Plant Service Water Effluent Line	S <sup>(4)</sup>	NA	R	Q
c. Plant Circulation Water Line**	S <sup>(4)</sup>	NA	N/A	R
4. TANK LEVEL INDICATING DEVICES				
a. Cycled Condensate Storage	D*	NA	R	NA
b. Reactor Core Isolation Cooling	D*	NA	R	NA

\*During liquid additions to the tank.

\*\* The plant circulation water (CW) flow rate measurement device is based upon the CW pump breaker position and an analog signal that specifies a preset flow rate.

TABLE 2.7-2 (Continued)

RADIOACTIVE LIQUID EFFLUENT MONITORING INSTRUMENTATION  
SURVEILLANCE REQUIREMENTS

TABLE NOTATIONS

- (1) The CHANNEL FUNCTIONAL TEST shall also demonstrate that automatic isolation of this pathway occurs and that the MCR ARPR LAN provides annunciation and event display in response to each of the following conditions:
  1. Instrument indicates measured levels above the alarm/trip (HIGH) setpoint.
  2. Detector failure (LOW FAIL, HI FAIL).
  3. Sample flow failure (EXTERNAL FAIL).
  4. Instrument not set in normal operate mode (CALIBRATE, MAINTENANCE, or STANDBY.)\*
  
- (2) The CHANNEL FUNCTIONAL TEST shall also demonstrate that the MCR ARPR LAN responds with annunciation and event display to each of the following conditions:
  1. Instrument indicates measured levels above the alarm (HIGH) setpoint.
  2. Detector failure (LOW FAIL, HI FAIL).
  3. Sample flow failure (EXTERNAL FAIL).
  4. Instrument not set in normal operate mode (CALIBRATE, MAINTENANCE, or STANDBY.)

---

\*A demonstration of automatic isolation of the release pathway is not applicable to this condition.

TABLE 2.7-2 (Continued)RADIOACTIVE LIQUID EFFLUENT MONITORING INSTRUMENTATION  
SURVEILLANCE REQUIREMENTSTABLE NOTATIONS

- (3) The initial CHANNEL CALIBRATION shall be performed using one or more of the reference standards certified by the National Institute of Standards and Technology (NIST) or using standards that have been obtained from suppliers that participate in measurement assurance activities with NIST. These standards shall permit calibrating the system over its intended range of energy and measurement range. For subsequent CHANNEL CALIBRATION, sources that have been related to the initial calibration shall be used.
- (4) CHANNEL CHECK shall consist of verifying indication of flow during periods of discharge. CHANNEL CHECKS are required when continuous, periodic, or batch releases are made.
- (5) The Channel Check performed from the MCR ARPR LAN also verifies communication.

3.0 GASEOUS EFFLUENTS3.1 Introduction

Gaseous effluents from CPS are released on both a batch and continuous basis. Gaseous effluents are normally discharged on a long term basis. High volume Continuous Containment Purge and mechanical vacuum pump discharge may be considered short term releases.

There are two gaseous effluent release points to the environment: the Common Station HVAC Stack and the Standby Gas Treatment System (SGTS) Stack. The height of these stacks is such that all gaseous effluents are treated as mixed-mode releases (reference Table 9.2-1). The SGTS is an Engineered Safety Feature filter system utilized following an accident to reduce iodine and particulate activity in gases leaking from the primary containment and which are potentially present in the secondary containment. The Common Station HVAC Stack ("HVAC Stack") receives process and ventilation exhaust from the following inputs:

- 1) Continuous Containment Purge (CCP)
- 2) Containment Building Ventilation
- 3) Turbine Building Ventilation
- 4) Radwaste Building Ventilation
- 5) Auxiliary Building Ventilation
- 6) Fuel Building Ventilation
- 7) Auxiliary Building Refrigerant Purge
- 8) Laboratory Ventilation System
- 9) Counting/Equipment Decon Rooms Ventilation
- 10) Steam Packing Exhauster
- 11) Mechanical Vacuum Pump
- 12) Drywell Purge

The effluent exiting the SGTS stack is monitored at the SGTS stack and the combined inputs to the HVAC stack are monitored at the HVAC stack. All inputs to the HVAC Stack, with the exception of input numbers 7 through 10, can be monitored prior to entering the stack.

Figure 3.1-1 delineates the CPS site boundary for implementation of gaseous effluent 10CFR20 and 10CFR50, Appendix I Release Rate Limits.

3.2 Gaseous Effluent Release Point Monitoring

3.2.1 HVAC Stack Process Radiation Monitoring (PRM) System

The HVAC Stack inputs are monitored for radioactivity prior to discharge to the environment by the HVAC Stack PRM. The PRM detector configuration provides effluent monitoring using nine (9) channels as follows:

- 1) Beta scintillator for particulates
- 2) Alpha surface barrier detector to account for the radon/thoron contribution to the beta particulate measurement
- 3) Gamma scintillator for iodine
- 4) Iodine background subtraction
- 5) Beta scintillator for low range noble gas
- 6) Energy-compensated Geiger-Mueller (G-M) detector for high range noble gas
- 7) Energy-compensated G-M detector for gamma area subtraction
- 8) Sample pressure indication at the HVAC PRM
- 9) Sample flow rate indication at the HVAC PRM

This monitor has one control function. Upon detection of activity that exceeds the high alarm setpoint on any channel, a failure of any channel (low or high) loss of AC power to the monitor, or flow failure the HVAC Accident Range PRM (ORIX-PR012) automatically transfers from a "STANDBY" condition to in service. Also, an annunciator alarms in the Main Control Room where proper response actions will be initiated in accordance with CPS procedures.

3.2.2 SGTS Stack Process Radiation Monitoring (PRM) System

As discussed in section 3.1, the SGTS is used to reduce post-accident concentrations of radioactivity in the primary and secondary containment via filter trains. The SGTS Stack PRM monitors the gaseous effluent of the filter trains at the SGTS Stack prior to release to the environment. The PRM detector configuration utilizes nine (9) channels as follows:

- 1) Beta scintillator for particulates
- 2) Gamma scintillator for iodine

- 3) Iodine background subtraction
- 4) Beta scintillator for low range noble gas
- 5) Energy-compensated G-M detector for intermediate range noble gas
- 6) Energy-compensated G-M detector for gamma area subtraction
- 7) Alpha surface barrier detector to account for the radon/thoron contribution to the beta particulate measurement
- 8) Sample pressure indication at the SGTS PRM
- 9) Sample flow-rate indication at the SGTS PRM

This monitor has no control function but annunciates in the Main Control Room where proper response actions will be initiated in accordance with CPS procedures.

### 3.3 Main Condenser Off-Gas Monitoring System

#### 3.3.1 Pre-Treatment Air Ejector Off-Gas Process Radiation Monitor (PRM)

The Pre-Treatment Off-Gas PRM monitors hydrogen recombiner effluent for gross noble gas radioactivity. This effluent is then routed to the charcoal adsorbers for eventual release to the environment via the station HVAC Stack (see Figure 3.3-1). The PRM detector configuration consists of a single energy-compensated G-M detector mounted in a gas volume.

The monitor has no control function but annunciates in the Main Control Room where proper response actions will be initiated in accordance with CPS procedures.

3.3.2 Post-Treatment Air Ejector Off-Gas Process Radiation Monitor (PRM)

The Post-Treatment Off-Gas PRM monitors the gaseous radioactivity at upstream, intermediate or downstream sections of the charcoal adsorber beds prior to the effluent entering the station HVAC Stack for release to the environment (see Figure 3.3-1). The PRM detector configuration is as described for the HVAC Stack PRM (Section 3.2.1).

The monitor has two control functions. Upon detection of noble gas activity in excess of the ALERT setpoint, the charcoal adsorber bypass valves shut (if in the charcoal bypass mode) and the off-gas is routed through the adsorbers.

Should noble gas activity exceed the HIGH setpoint, or upon PRM failure, the off-gas system is automatically isolated from the HVAC Stack and a reactor scram may occur if loss of condenser vacuum occurs.

The Main Condenser Off-Gas Treatment System is shown in Figure 3.3-1.

3.4 10CFR20 Release Rate Limits

The Operation and Surveillance Requirements concerning 10CFR20 Release Rate Limits are specified in Section 3.4.1. Dose Rate calculations for ensuring compliance with these limits are discussed in Sections 3.4.2 and 3.4.3.



3.4.1 10CFR20 Release Rate Limits - Operation and Surveillance Requirements

OPERATION REQUIREMENT

---

The dose rate due to radioactive materials released in gaseous effluents from the site to areas at and beyond the SITE BOUNDARY (see Figure 3.1-1) shall be limited to the following:

- a. For noble gases: Less than or equal to 500 mrem/yr to the total body and less than or equal to 3000 mrem/yr to the skin, and
- b. For iodine-131, for iodine-133, for tritium, and for all radionuclides in particulate form with half lives greater than 8 days: Less than or equal to 1500 mrem/yr to any organ.

This requirement applies at all times.

REMEDIAL REQUIREMENT:

With the dose rate(s) exceeding the above limits, immediately restore the release rate to within the above limit(s).

SURVEILLANCE REQUIREMENTS

---

- 3.4.1.1 The dose rate due to noble gases in gaseous effluents shall be determined to be within the above limits in accordance with the methodology and parameters in Section 3.4.2 by obtaining representative samples and performing analyses in accordance with the sampling and analysis program specified in Table 3.4-1.
- 3.4.1.2 The dose rate due to iodine-131, iodine-133, tritium, and all radionuclides in particulate form with half lives greater than 8 days in gaseous effluents shall be determined to be within the above limits in accordance with the methodology and parameters in Section 3.4.3 by obtaining representative samples and performing analyses in accordance with the sampling and analysis program specified in Table 3.4-1.

TABLE 3.4-1

RADIOACTIVE GASEOUS WASTE SAMPLING AND ANALYSIS PROGRAM

<u>Gaseous Release Type</u>	<u>Sampling Frequency</u>	<u>Analysis Frequency</u>	<u>Type of Activity Analysis</u>	<u>Lower Limit of Detection LLD (<math>\mu\text{Ci/cc}</math>)</u>
<b>A. Station HVAC Exhaust</b>				
1. Noble Gas and Tritium Release	W <sup>2</sup> Grab	W <sup>2</sup>	Principal Gamma Emitters <sup>1</sup> H-3	$\leq 1.00\text{E}-04$ $\leq 1.00\text{E}-06$
2. Iodines Release	Continuous <sup>3</sup>	W <sup>4</sup>	I-131 I-133	$\leq 1.00\text{E}-12$ $\leq 1.00\text{E}-10$
3. Particulates Release	Continuous <sup>3</sup>	W <sup>4</sup>	Principal Gamma Emitters <sup>1</sup>	$\leq 1.00\text{E}-11$
		M Composite	Gross Alpha Activity	$\leq 1.00\text{E}-11$
		Q Composite	Sr-89, Sr-90 Activity	$\leq 1.00\text{E}-11$
<b>B. Standby Gas Treatment System Exhaust, when flow exists</b>				
1. Noble Gas and Tritium Release	Each Release Grab	Each Release	Principal Gamma Emitters <sup>1</sup> H-3	$\leq 1.00\text{E}-04$ $\leq 1.00\text{E}-06$
2. Iodines Release	Continuous <sup>3</sup>	W <sup>4</sup>	I-131 I-133	$\leq 1.00\text{E}-12$ $\leq 1.00\text{E}-10$
3. Particulates Release	Continuous <sup>3</sup>	W <sup>4</sup>	Principal Gamma Emitters <sup>1</sup>	$\leq 1.00\text{E}-11$
		M Composite	Gross Alpha Activity	$\leq 1.00\text{E}-11$
		Q Composite	Sr-89, Sr-90 Activity	$\leq 1.00\text{E}-11$
<b>C. Drywell Purge and High Volume Containment Ventilation, modes 4 and 5 only <sup>5,6</sup></b>				
1. Noble Gas and Tritium Release	Upon Initiation Of Flow Grab	Each Release	Principal Gamma Emitters <sup>1</sup> H-3	$\leq 1.00\text{E}-04$ $\leq 1.00\text{E}-06$
<b>D. Mechanical Vacuum Pump <sup>5,6</sup></b>				
1. Noble Gas and Tritium Release	Upon Initiation Of Flow Grab	Each Release	Principal Gamma Emitters <sup>1</sup> H-3	$\leq 1.00\text{E}-04$ $\leq 1.00\text{E}-06$

## TABLE 3.4-1 (Continued)

RADIOACTIVE GASEOUS WASTE SAMPLING AND ANALYSIS PROGRAMTABLE NOTATIONS

<sup>a</sup>The LLD is defined, for purposes of these specifications, as the smallest concentration of radioactive material in a sample that will yield a net count, above system background, that will be detected with 95% probability with only 5% probability of falsely concluding that a blank observation represents a "real" signal.

For a particular measurement system, which may include radiochemical separation:

$$LLD = 4.66 s_b / [E \times V \times 2.22E+06 \times Y \times \exp(-\lambda \Delta t)]$$

Where:

LLD is the "a priori" lower limit of detection as defined above, as microcuries per unit mass or volume,

$s_b$  is the standard deviation of the background counting rate or of the counting rate of a blank sample as appropriate, as

counts per minute,  $s_b = \sqrt{\frac{R_{bkg}}{t}}$

where  $R_{bkg}$  = background count rate  
 $t$  = the background count time

$E$  is the counting efficiency, as counts per disintegration,

$V$  is the sample size in units of mass or volume,

2.22E+06 is the number of disintegrations per minute per microcurie,

$Y$  is the fractional radiochemical yield, when applicable,

$\lambda$  is the radioactive decay constant for the particular radionuclide ( $\text{sec}^{-1}$ ) and

$\Delta t$  for plant effluents is the elapsed time between the midpoint of sample collection and the midpoint of the counting interval (sec).

Typical values of  $E$ ,  $V$ ,  $Y$ , and  $\Delta t$  should be used in the calculation.

TABLE 3.4-1 (Continued)RADIOACTIVE GASEOUS WASTE SAMPLING AND ANALYSIS PROGRAMTABLE NOTATIONS (Continued)

It should be recognized that the LLD is defined as an a priori (before the fact) limit representing the capability of a measurement system and not as an a posteriori (after the fact) limit for a particular measurement.

<sup>1</sup>The principal gamma emitters are: Kr-87, Kr-88, Xe-133, Xe-133m, Xe-135, and Xe-138 in noble gas releases and Mn-54, Fe-59, Co-58, Co-60, Zn-65, Mo-99, I-131, Cs-134, Cs-137, Ce-141 and Ce-144 in iodine and particulate releases. Other gamma peaks that are identifiable, together with those of the above nuclides, shall be analyzed and reported in the Radioactive Effluent Release Report pursuant to Technical Specification 5.6.3 in the format outlined in Regulatory Guide 1.21, Appendix B, Revision 1, June 1974.

<sup>2</sup>Sampling and analysis shall also be performed following shutdown, startup, or a THERMAL POWER change exceeding 15% of RATED THERMAL POWER within a 1-hour period.

<sup>3</sup>The ratio of the sample flow rate to the sampled stream flow rate shall be known for the time period covered by each dose or dose rate calculation made in accordance with Sections 3.4.1, 3.5.1 and 3.5.2.

<sup>4</sup>Samples shall be changed at least once per 7 days and analysis shall be completed within 48 hours after changing, or after removal from sampler. Sampling shall also be performed at least once per 24 hours for at least 7 days following each shutdown, startup, or THERMAL POWER change exceeding 15% of RATED THERMAL POWER in 1-hour period and analyses shall be completed within 48 hours of changing. When samples collected for 24 hours or less are analyzed, the corresponding LLDs may be increased by a factor of 10. Twenty-four (24) hour sampling requirements do apply if: (1) analysis shows that the DOSE EQUIVALENT I-131 concentration in the primary coolant has increased more than a factor of 3, and (2) the noble gas monitor on the applicable PRM (HVAC or SGTS) shows that effluent activity has increased more than a factor of 3.

<sup>5</sup>Samples are taken from the in-service HVAC PRM.

<sup>6</sup>Iodines and Particulates released from these discharges are accounted for in the weekly samples taken in accordance with items A2 and A3 above.

3.4.2 Dose Rate Due to Noble Gases

In order to comply with Section 3.4.1.(a), the dose rate at or beyond the site boundary due to noble gases shall be calculated as follows:

$$D_t = \sum_i K_i * shf * \sum_v [(X/Q)_{vr} * Q_{iv}] \quad (1)$$

= total body dose rate at time of release,  
mrem/year

$$D_s = \sum_i shf * (L_i + 1.1M_i) * \sum_v [(X/Q)_{vr} * Q_{iv}] \quad (2)$$

= skin dose rate at time of release,  
mrem/year

The terms in the above equations are defined in section 3.4.3.

3.4.3 Dose Rate Due to Radioiodines, Particulates and Tritium

In order to comply with Section 3.4.1(b), organ dose rates due to radioiodines (I-131, I-133), particulates with half-lives > 8 days and tritium shall be calculated as follows:

$$D_j = \sum [P_{ij} * Q_{ivm} * (X/Q)_v] \quad (3)$$

= organ dose rate at time of release,  
mrem/yr

The terms used in equations (1) through (3) are defined as follows:

$K_i$  = The total body dose factor due to gamma emissions for each identified noble gas radionuclide  $i$ , mrem/yr per  $\mu\text{Ci}/\text{m}^3$  from Table 3.4-2

$L_i$  = The skin dose factor due to beta emissions for each identified noble gas radionuclide  $i$ , mrem/yr per  $\mu\text{Ci}/\text{m}^3$  from Table 3.4-2

$M_i$  = The air dose factor due to gamma emissions for each identified noble gas radionuclide  $i$ , mrad/yr per  $\mu\text{Ci}/\text{m}^3$  (1.1 mrem/mrad converts air dose to skin dose) from Table 3.4-2

shf = Noble gas dose shielding factor, which is set to 1.

$P_{ij}$  = The dose factor for non-noble gas radionuclide  $i$  and organ  $j$  which includes pathway transport parameters, receptor usage factors and the dosimetry of the exposure. The dose factors for the inhalation, mrem/yr per  $\mu\text{Ci}/\text{m}^3$ , pathway are listed in Table 3.4-3 (CHILD). Dose factors are based on NUREG-0133, Section 5.2.1.1 assumptions unless otherwise stated.

$Q_{iv}$  = The release rate of noble gas radionuclide  $i$  in gaseous effluent from mixed mode release point  $v$ ,  $\mu\text{Ci}/\text{sec}$

$Q_{ivm}$  = The release rate of non-noble gas radionuclide  $i$  in gaseous effluent from mixed mode release point  $v$ ,  $\mu\text{Ci}/\text{sec}$

$(X/Q)_{vr}$  = The highest value of the annual atmospheric dispersion factor from release point  $v$  at the site boundary, for all sectors,  $(\text{sec}/\text{m}^3)$ .

$(X/Q)_v$  = The highest calculated average relative concentration  $(X/Q)$  for any area at or beyond the site boundary from mixed mode release point  $v$ ,  $\text{sec}/\text{m}^3$ .

$D_j$  is calculated for each of six organs and the total body; the maximum  $D_j$  value is then used to determine compliance with Section 3.4.1(b).

The factors  $K_i$ ,  $L_i$ , and  $M_i$  relate the radionuclide airborne concentrations to various dose rates assuming a semi-infinite cloud. These factors are listed in Table 3.4-2 and were obtained from Table B-1 of Regulatory Guide 1.109 after multiplying the values by the conversion  $10^6$  pCi/ $\mu\text{Ci}$ .

10CFR20 organ dose rate calculations are limited to the inhalation pathway only. Section 3.4.1(a) is applicable to the unrestricted area location characterized by the  $(X/Q)_v$  value which results in the maximum total body or skin dose commitment. Should the total body and skin locations differ, the selected location shall be that which minimizes allowable release rates.

There are unrestricted areas within the CPS site boundary which are utilized by members of the public for residences, farming, recreation and camping. These areas are identified in Table 3.4-4. Table 3.4-4 will be revised to remain consistent with the most recent land use census.

TABLE 3.4-2

DOSE FACTORS FOR NOBLE GASES AND DAUGHTERS\*

Radionuclide	Total Body Dose Factor $K_i$ (mrem/yr per $\mu\text{Ci}/\text{m}^3$ )	Skin Dose Factor $L_i$ (mrem/yr per $\mu\text{Ci}/\text{m}^3$ )	Gamma Air Dose Factor $M_i$ (mrad/yr per $\mu\text{Ci}/\text{m}^3$ )	Beta Air Dose Factor $N_i$ (mrad/yr per $\mu\text{Ci}/\text{m}^3$ )
Kr-85m	1.17E+03	1.46E+03	1.23E+03	1.97E+03
Kr-85	1.61E+01	1.34E+03	1.72E+01	1.95E+03
Kr-87	5.92E+03	9.73E+03	6.17E+03	1.03E+04
Kr-88	1.47E+04	2.37E+03	1.52E+04	2.93E+03
Kr-89	1.66E+04	1.01E+04	1.73E+04	1.06E+04
Kr-90	1.56E+04	7.29E+03	1.63E+04	7.83E+03
Xe-131m	9.15E+01	4.76E+02	1.56E+02	1.11E+03
Xe-133m	2.51E+02	9.94E+02	3.27E+02	1.48E+03
Xe-133	2.94E+02	3.06E+02	3.53E+02	1.05E+03
Xe-135m	3.12E+03	7.11E+02	3.36E+03	7.39E+02
Xe-135	1.81E+03	1.86E+03	1.92E+03	2.46E+03
Xe-137	1.42E+03	1.22E+04	1.51E+03	1.27E+04
Xe-138	8.83E+03	4.13E+03	9.21E+03	4.75E+03
Ar-41	8.84E+03	2.69E+03	9.30E+03	3.28E+03

\*The listed dose factors are for radionuclides that may be detected in gaseous effluents.

TABLE 3.4-3

INHALATION PATHWAY DOSE RATE FACTORS (CHILD) -  $P_{ij}$   
(mrem/yr per  $\mu\text{Ci}/\text{m}^3$ )

<u>ORGAN</u> <u>ISOTOPE</u>	<u>BONE</u>	<u>LIVER</u>	<u>T.BODY</u>	<u>THYROID</u>	<u>KIDNEY</u>	<u>LUNG</u>	<u>GI-LLI</u>
H-3	NO DATA	1.12E+03	1.12E+03	1.12E+03	1.12E+03	1.12E+03	1.12E+03
P-32	2.60E+06	1.14E+05	9.88E+04	NO DATA	NO DATA	NO DATA	4.22E+04
CR-51	NO DATA	NO DATA	1.54E+02	8.55E+01	2.43+01	1.70E+04	1.08E+03
MN-54	NO DATA	4.29E+04	9.51E+03	NO DATA	1.00E+04	1.58E+06	2.29E+04
FE-55	4.74E+04	2.52E+04	7.77E+03	NO DATA	NO DATA	1.11E+05	2.87E+03
FE-59	2.07E+04	3.34E+04	1.67E+04	NO DATA	NO DATA	1.27E+06	7.07E+04
CO-58	NO DATA	1.77E+03	3.16E+03	NO DATA	NO DATA	1.11E+06	3.44E+04
CO-60	NO DATA	1.31E+04	2.26E+04	NO DATA	NO DATA	7.07E+06	9.62E+04
NI-63	8.21E+05	4.63E+04	2.80E+04	NO DATA	NO DATA	2.75E+05	6.33E+03
ZN-65	4.26E+04	1.13E+05	7.03E+04	NO DATA	7.14E+04	9.95E+05	1.63E+04
RB-86	NO DATA	1.98E+05	1.14E+05	NO DATA	NO DATA	NO DATA	7.99E+03
SR-89	5.99E+05	NO DATA	1.72E+04	NO DATA	NO DATA	2.16E+06	1.67E+05
SR-90	1.01E+08	NO DATA	6.49E+06	NO DATA	NO DATA	1.48E+07	3.43E+05
Y-90	4.11E+03	NO DATA	1.11E+02	NO DATA	NO DATA	2.62E+05	2.68E+05
Y-91	9.14E+05	NO DATA	2.44E+04	NO DATA	NO DATA	2.63+06	1.84E+05
ZR-95	1.90E+05	4.18E+04	3.70E+04	NO DATA	5.96E+04	2.23E+06	6.11E+04
NB-95	2.35E+04	9.18E+03	6.55E+03	NO DATA	8.62E+03	6.14E+05	3.70E+04
MO-99	NO DATA	1.72E+02	4.26E+01	NO DATA	3.92E+02	1.35E+05	1.27E+05
TC-99m	1.78E-03	3.48E-03	5.77E-02	NO DATA	5.07E-02	9.51E+02	4.81E+03
RU-103	2.79E+03	NO DATA	1.07E+03	NO DATA	7.03E+03	6.62E+05	4.48E+04
RU-106	1.36E+05	NO DATA	1.69E+04	NO DATA	1.84E+05	1.43E+07	4.29E+05
AG-110m	1.69E+04	1.14E+04	9.14E+03	NO DATA	2.12E+04	5.48E+06	1.00E+05
TE-125m	6.73E+04	2.33E+03	9.14E+02	1.92E+03	NO DATA	4.77E+05	3.38E+04
TE-127m	2.49E+04	8.56E+03	3.03E+03	6.07E+03	6.36E+04	1.48E+06	7.14E+04
TE-129m	1.92E+04	6.85E+03	3.04E+03	6.33E+03	5.03E+04	1.76E+06	1.82E+05
I-130	8.18E+03	1.64E+04	8.44E+03	1.85E+06	2.45E+04	NO DATA	5.11E+03
I-131	4.81E+04	4.81E+04	2.73E+04	1.62E+07	7.88E+04	NO DATA	2.84E+03
I-132	2.12E+03	4.07E+03	1.88E+03	1.94E+05	6.25E+03	NO DATA	3.20E+03
I-133	1.66E+04	2.03E+04	7.70E+03	3.85E+06	3.38E+04	NO DATA	5.48E+03
I-134	1.17E+03	2.16E+03	9.95E+02	5.07E+04	3.30E+03	NO DATA	9.55E+02
I-135	4.92E+03	8.73E+03	4.14E+03	7.92E+05	1.34E+04	NO DATA	4.44E+03
CS-134	6.51E+05	1.01E+06	2.25E+05	NO DATA	3.30E+05	1.21E+05	3.84E+03
CS-136	6.51E+04	1.71E+05	1.16E+05	NO DATA	9.55E+04	1.45E+04	4.18E+03
CS-137	9.07E+05	8.25E+05	1.28E+05	NO DATA	2.82E+05	1.04E+05	3.62E+03
BA-140	7.40E+04	6.48E+01	4.33E+03	NO DATA	2.11E+01	1.74E+06	1.02E+05
CE-141	3.92E+04	1.95E+04	2.90E+03	NO DATA	8.55E+03	5.44E+05	5.66E+04
CE-144	6.77E+06	2.12E+06	3.62E+05	NO DATA	1.17E+06	1.20E+07	3.89E+05
PR-143	1.85E+04	5.55E+03	9.14E+02	NO DATA	3.00E+03	4.33E+05	9.73E+04
ND-147	1.08E+04	8.73E+03	6.81E+02	NO DATA	4.81E+03	3.28E+05	8.21E+04



TABLE 3.4-4

LOCATION OF MEMBERS OF THE PUBLIC WITHIN THE CPS SITE BOUNDARY  
AND THEIR ASSOCIATED OCCUPANCY FACTORS\*

<u>Location</u>	<u>Distance (mile/meter)</u>	<u>Sector</u>	<u>Occupancy (hrs/yr)</u>
Road	0.3/495	SE	243(1)
Agricultural Acreage(2)	0.9/1372	SSW	966(3)
Clinton Lake	0.2/335	NW	2208(4)
Department of Conservation Recreation Area	0.8/1287	ESE	2208(5)
Residence	0.8/1219	SW	8760
Residence	1.5/2414	WSW	8760
Residence	1.7/2736	SSE	8760

- (1) Assumes travel on road for forty minutes per day.
- (2) Maximum farm acreage (276) within site boundary.
- (3) Assumes 3.5 hours in field per acre farmed.
- (4) Assumes continuous occupation on Clinton Lake for the months of June, July, and August.
- (5) Assumes continuous occupation on Department of Conservation camping areas for the months of June, July, and August.

\*Doses for such MEMBERS OF THE PUBLIC are provided in the Radioactive Effluent Release Report as given in Section 6.3.2.

3.5 10CFR50, APPENDIX I RELEASE RATE LIMITS

The Operation and Surveillance Requirements concerning 10CFR50 (Appendix I) Release Rate Limits are specified in Sections 3.5.1 and 3.5.2. Dose calculations for ensuring compliance with these limits are discussed in Sections 3.5.3 and 3.5.4.

3.5.1 Noble Gas Dose - Operation and Surveillance Requirements

OPERATION REQUIREMENT

---

The air dose due to noble gases released in gaseous effluents, from each reactor unit, to areas at and beyond the SITE BOUNDARY (see Figure 3.1-1) shall be limited to the following:

- a. During any calendar quarter: Less than or equal to 5 mrad for gamma radiation and less than or equal to 10 mrad for beta radiation, and
- b. During any calendar year: Less than or equal to 10 mrad for gamma radiation and less than or equal to 20 mrad for beta radiation.

This requirement applies at all times.

REMEDIAL REQUIREMENT:

- a. With the calculated air dose from radioactive nobles gases in gaseous effluents exceeding any of the above limits, in lieu of a Licensee Event Report, prepare and submit to the Regional Administrator of the Regional Office of the NRC within 30 days a Special Report that identifies the cause(s) for exceeding the limit(s) and defines the corrective actions that have been taken to reduce the releases and the proposed corrective actions to be taken to assure that subsequent releases will be in compliance with the above limits.

SURVEILLANCE REQUIREMENTS

---

- 3.5.1.1 Cumulative dose contributions for the current calendar quarter and current calendar year for noble gases shall be determined in accordance with the methodology and parameters described in Section 3.5.3 at least once per 31 days.

3.5.2 Iodine-131, Iodine-133, Tritium, and Radionuclides in Particulate Form - Operation and Surveillance Requirements

OPERATION REQUIREMENT

---

The dose to a MEMBER OF THE PUBLIC from iodine-131, iodine-133, tritium, and all radionuclides in particulate form with half-lives greater than 8 days in gaseous effluents released to areas at and beyond the SITE BOUNDARY (see Figure 3.1-1) shall be limited to the following:

- a. During any calendar quarter: Less than or equal to 7.5 mrem to any organ, and
- b. During any calendar year: Less than or equal to 15 mrem to any organ.

This requirement applies at all times.

REMEDIAL REQUIREMENT:

- a. With the calculated dose from the release of iodine-131, iodine-133, tritium, and radionuclides in particulate form with half lives greater than 8 days, in gaseous effluents exceeding any of the above limits prepare and submit to the Regional Administrator of the Regional Office of the NRC within 30 days a Special Report that identifies the cause(s) for exceeding the limit and defines the corrective actions that have been taken to reduce the releases and the proposed corrective actions to be taken to assure that subsequent releases will be in compliance with the above limits.

SURVEILLANCE REQUIREMENTS

---

- 3.5.2.1 Cumulative dose contributions for the current calendar quarter and current calendar year for iodine-131, iodine-133, tritium, and radionuclides in particulate form with half-lives greater than 8 days shall be determined in accordance with the methodology and parameters described in Section 3.5.4 at least once per 31 days.

3.5.3 Noble Gas Air Dose Equations

The air dose at or beyond the site boundary due to noble gases released in gaseous effluent will be determined using the following equations.

3.5.3.1 During any calendar quarter or calendar year, for gamma radiation:

$$D_{\gamma} = 3.17E-08 * \sum_i [M_i * (X/Q)_v * Q_{iv}] \quad (4)$$

3.5.3.2 During any calendar quarter or calendar year, for beta radiation:

$$D_{\beta} = 3.17E-08 * \sum_i [N_i * (X/Q)_v * Q_{iv}] \quad (5)$$

where

$M_i$  = The gamma air dose factor for each identified noble gas radionuclide  $i$ , mrad/year per  $\mu\text{Ci}/\text{m}^3$  ( $M_i$  values are listed in Table 3.4-2).

$N_i$  = The beta air dose factor for each identified noble gas radionuclide  $i$ , mrad/year per  $\mu\text{Ci}/\text{m}^3$  ( $N_i$  values are listed in Table 3.4-2).

$(X/Q)_v$  = The highest calculated average relative concentration from mixed-mode release points for areas at or beyond the site boundary,  $\text{sec}/\text{m}^3$ .

$Q_{iv}$  = The total release of noble gas radionuclide  $i$  for long-term releases from mixed-mode release points,  $\mu\text{Ci}$ . Releases shall be cumulative over the calendar quarter or year, as appropriate.

$3.17E-08$  = The inverse of the number of seconds in a year.

Section 3.5.1 noble gas dose calculations are evaluated at the site boundary location where maximum air doses prevail. Should the beta and gamma locations differ, the selected location shall be that which minimizes allowable release rates due to the gamma component.

3.5.4 Radioiodines, Particulates and Tritium Dose Equations

The dose to an individual at or beyond the site boundary due to radioiodines (I-131, I-133), tritium and particulates with half-lives > 8 days, will be determined using the follow equation:

for any calendar quarter or calendar year,

$$D_j = 3.17E-08 * f_0 * \sum_i [R_{ija}^P * W_{pv} * Q_{iv}] \quad (6)$$

where

$Q_{iv}$  = The releases of radionuclide i (I-131, I-133, tritium and particulates with half-lives greater than 8 days) for releases from vent v for mixed-mode releases,  $\mu\text{Ci}$ . Releases shall be cumulative over the calendar quarter or year, as appropriate.

$W_{pv}$  = The annual average dispersion parameter for estimating the dose to an individual as appropriate to pathway p and release point v, at a controlling location, for mixed-mode releases.

=  $\overline{(X/Q)}$ ,  $\text{sec}/\text{m}^3$ , for the inhalation pathway and tritium at the location of the critical receptor.

=  $\overline{(D/Q)}_m$ ,  $\text{m}^{-2}$ , for the food and ground plane pathways at the location of the critical receptor.

$3.17E-08$  = The inverse of the number of seconds in a year.

$R_{ija}^P$  = The dose factor for each identified radionuclide i, pathway (P), organ (j), and age group (a),  $\text{m}^2\text{-mrem}/\text{year}$  per  $\mu\text{Ci}/\text{sec}$  or  $\text{mrem}/\text{year}$  per  $\mu\text{Ci}/\text{m}^3$ .

$f_0$  = Occupancy factor which is set to 1

Section 3.5.2 is applicable to the location at or beyond the site boundary where the combination of existing pathways and receptor age groups indicates the maximum potential exposure. The inhalation and ground plane exposure pathways exist at all locations; other pathways exist as determined by the most current land use census.

3.5.4.1 Dose Factor For Radionuclide i ( $R_{ija}^P$ )

The  $R_{ija}^P$  values used to calculate  $D_j$  in equation (6) are determined separately for each of the potential exposure pathways, namely:

- Inhalation (I)
- Ground Plane Contamination (G)
- Grass-Cow/Goat-Milk (C)
- Grass-Cow-Meat (M)
- Vegetation (V)

The  $R_{ija}^P$  parameter is independent of the duration of gaseous releases and is calculated using the methodology discussed in the remainder of this section.

3.5.4.1.1 Calculation of the Inhalation Pathway Factor,  $R_{ija}^I$ 

$$R_{ija}^I = K' (BR)_a (DFA_i)_{ja}, \text{ mrem/year per } \mu\text{Ci}/\text{m}^3 \quad (7)$$

where

- $K'$  = A units conversion constant,  $10^6$  pCi/ $\mu$ Ci
- $(BR)_a$  = The breathing rate of the receptor age group (a),  $\text{m}^3/\text{year}$
- = 1400 (infant)
  - = 3700 (child)
  - = 8000 (teen and adult)

Values for  $(BR)_a$  are obtained from NUREG-0133, pg. 32

$(DFA_{ij})_a$  = The organ inhalation dose factor for receptor of age group (a) for radionuclide i, and organ j, mrem/pCi. Values for  $(DFA_i)_a$  were obtained from Tables E-7 through E-10 of Regulatory Guide 1.109 and are presented in Tables 3.5-1 through 3.5-4 of this manual.

3.5.4.1.2 Calculation of the Ground Plane Pathway Factor,  $R_{ija}^G$ 

$$R_{ija}^G = K'K'' (SF) (DFG_{ij}) [(1 - (\exp(-\lambda_i t))) / \lambda_i], \quad (8)$$

$m^2$ -mrem/year per  $\mu\text{Ci}/\text{sec}$

where

- $K'$  = A units conversion constant,  $10^6$  pCi/ $\mu\text{Ci}$
- $K''$  = A units conversion constant, 8760 hour/year
- $SF$  = The shielding factor, dimensionless
- = 0.7 as suggested in Table E-15 of Regulatory Guide 1.109
- $DFG_{ij}$  = The ground plane dose conversion factor for radionuclide  $i$  and organ  $j$ , mrem/hour per pCi/ $m^2$ . Values for  $DFG_i$  were obtained from Table E-6 of Regulatory Guide 1.109 and are presented in Table 3.5-5 of this manual.
- $\lambda_i$  = The decay constant for radionuclide  $i$ ,  $\text{sec}^{-1}$
- $t$  = The exposure time, sec
- =  $6.31\text{E}+08$  sec (20 years)

3.5.4.1.3 Calculation of the Grass-Cow/Goat-Milk Pathway Factor,  $R_{ija}^C$ 

$$R_{ija}^C = K' [Q_F (U_{ap}) / (\lambda_i + \lambda_w)] F_m(r) (DFL_i)_{ja} \quad (9)$$

\*  $[f_p f_s / Y_p + (1 - f_p f_s) \exp(-\lambda_i t_h) / Y_s] \exp(-\lambda_i t_h)$ ,

$m^2$ -mrem/yr per  $\mu\text{Ci}/\text{sec}$

where

- $K'$  = A units conversion constant,  $10^6$  pCi/ $\mu\text{Ci}$
- $Q_F$  = The cow/goat feed consumption rate, kg(wet)/day
- $U_{ap}$  = The receptor's milk consumption rate for age group (a), liters/year
- $Y_p$  = The agricultural productivity by unit area of pasture feed grass,  $\text{kg}/m^2$
- $Y_s$  = The agricultural productivity by unit area of stored feed,  $\text{kg}/m^2$

- $F_{mi}$  = The stable element transfer coefficient for nuclide  $i$  in milk, days/liter. These values are from Tables E-1 and E-2 of Regulatory Guide 1.109.
- $r$  = Fraction of deposited activity retained on feed grass, dimensionless
- $(DFL_i)_{ja}$  = The organ ingestion dose factor for radionuclide  $i$ , organ  $j$ , and the receptor in age group  $(a)$ , mrem/pCi. Values for  $(DFL_i)_{ja}$  were obtained from Tables E-11 through E-14 of Regulatory Guide 1.109 and are presented in Table 3.5-6 through 3.5-9 of this manual.
- $\lambda_i$  = The decay constant for radionuclide  $i$ ,  $\text{sec}^{-1}$ .
- $\lambda_w$  = The decay constant for removal of activity on leaf and plant surfaces by weathering,  $\text{sec}^{-1}$   
 =  $5.73\text{E-}07 \text{ sec}^{-1}$  (corresponding to a 14-day half-life)
- $t_f$  = The transport time from pasture to animal, to milk, to receptor, sec
- $t_h$  = The transport time from pasture to harvest, to animal, sec
- $f_p$  = Fraction of the year that the cow/goat is on pasture, dimensionless
- $f_s$  = Fraction of the cow/goat feed that is pasture grass while the cow/goat is on pasture, dimensionless

The input parameters for calculating  $R_{ija}^C$  are listed in Table 3.5-10.



Tritium

The concentration of tritium in milk is based on its airborne concentration rather than the deposition.

$$R_T^C = K'K''F_m Q_F U_{ap} (DFL_i)_{ja} * 0.75(0.5/H),$$

mrem/yr per  $\mu\text{Ci}/\text{m}^3$  (10)

where

$K''$  = A units conversion constant,  $10^3$  gm/kg

$H$  = The absolute atmospheric humidity

=  $8 \text{ gm}/\text{m}^3$  (NUREG-0133, p. 34)

0.75 = The fraction of total feed that is water, dimensionless

0.5 = The ratio of the specific activity of the feed grass water to the atmospheric water, dimensionless

The other parameters are as defined in the calculation of  $R_{ija}^C$

3.5.4.1.4 Calculation of the Grass-Cow-Meat Pathway Factor,  $R_{ija}^M$ 

$$R_{ija}^M = [K' Q_F (U_{ap}) / (\lambda_i + \lambda_w)] F_f(r) (DFL_i)_{ja} * [f_p f_s / Y_p + [(1 - f_p f_s) / Y_s] (\exp(-\lambda_i t_h))] * (\exp(-\lambda_i t_s))$$

m<sup>2</sup>-mrem/yr per  $\mu$ Ci/sec (11)

where

$K'$  = A units conversion constant,  $10^6$  pCi/ $\mu$ Ci

$U_{ap}$  = The receptor's meat consumption rate for age group (a), kg/year

$F_f$  = The stable element transfer coefficient, days/kg

$t_s$  = The transport time from pasture to animal to slaughter of meat animal to receptor, seconds

$t_h$  = The transport time from crop field to harvest to animal, seconds

$(DFL_i)_{ja}$  = The organ ingestion dose factor for radionuclide i, organ j, and the receptor in age group (a), mrem/pCi. Values for  $(DFL_i)_{ja}$  were obtained from Tables E-11 through E-14 of Regulatory Guide 1.109 and are presented in Table 3.5-6 through 3.5-9 of this manual.

The input parameters necessary for calculating  $R_{ija}^M$  are listed in Table 3.5-11. All other terms are as defined for equations (9) and (10).

#### Tritium

The concentration of tritium in meat is based on its airborne concentration rather than the deposition.

$$R_T^M = K' K'' F_f Q_F U_{ap} (DFL_i)_{ja} [0.75 (0.5/H)],$$

mrem/yr per  $\mu$ Ci/m<sup>3</sup> (12)

The terms in equation (12) are as defined in equations (10) and (11).

3.5.4.1.5 Calculation of the Vegetation Pathway Factor,  $R_{ipj}^V$ 

$$R_{ipj}^V = K' [(r) / [Y_v(\lambda_j + \lambda_w)]] (DFL_i)_{ja} * [U_a^L f_L (\exp(-\lambda_i t_L)) + U_a^S f_g (\exp(-\lambda_i t_h))],$$

m<sup>2</sup>-mrem/yr per  $\mu$ Ci/sec (13)

where

$K'$  = A units conversion constant, 10<sup>6</sup> pCi/ $\mu$ Ci

$U_a^L$  = The consumption rate of fresh leafy vegetation by the receptor in age group (a), kg/year

$U_a^S$  = The consumption rate of stored vegetation by the receptor in age group (a), kg/yr

$f_L$  = The fraction of the annual intake of fresh leafy vegetation grown locally, dimensionless

$f_g$  = The fraction of the annual intake of stored vegetation grown locally, dimensionless

$t_L$  = The average time between harvest of leafy vegetation and its consumption, seconds

$t_h$  = The average time between harvest of stored vegetation and its consumption, seconds

$Y_v$  = the vegetation area density, kg/m<sup>2</sup>

$(DFL_i)_{ja}$  = The organ ingestion dose factor for organ j, radionuclide i, and the receptor in age group (a), mrem per pCi. Values are tabulated in Table 3.5-6 through 3.5-9 of this manual.

The input parameters necessary for calculating  $R_{ipj}^V$  are listed in Table 3.5-12. All other terms are as defined for equations (9) and (14).

Tritium

The concentration of tritium in vegetation is based on its airborne concentration rather than the deposition.

$$R_T^V = K'K''(U_{afL}^L + U_{afg}^S)(DFL_i)_{ja} [0.75(0.5/H)],$$

mrem/yr per  $\mu\text{Ci}/\text{m}^3$  (14)

The terms in equation (14) are as defined in equations (10) and (13).

The pathway dose rate factors ( $R_{ija}^I$ ,  $R_{ija}^C$ ,  $R_{ija}^V$ ,  $R_{ija}^M$ ,  $R_i^G$ ), by age group are listed in Table 3.5-13 through 3.5-31.

3.6 Gaseous Radwaste (Offgas Treatment)

3.6.1 Gaseous Radwaste (Offgas Treatment) System - Operation and Surveillance Requirements

OPERATION REQUIREMENT

The GASEOUS RADWASTE (OFFGAS) TREATMENT SYSTEM shall be in operation. This requirement applies whenever the main condenser steam jet air ejector system is in operation.

REMEDIAL REQUIREMENT:

- a. With gaseous radwaste from the main condenser air ejector system being discharged without treatment for more than 7 days, prepare and submit to the Regional Administrator of the Regional Office of the NRC within 30 days a Special Report that includes the following information:
  - 1. Identification of any inoperable equipment or subsystems, and the reason for the inoperability.
  - 2. Action(s) taken to restore the inoperable equipment to OPERABLE status, and
  - 3. Summary description of action(s) taken to prevent a recurrence.

SURVEILLANCE REQUIREMENT

- 3.6.1.1 The GASEOUS RADWASTE (OFFGAS) TREATMENT SYSTEM shall be verified to be in operation once every 12 hours when the main condenser air ejector is in use to ensure that the main condenser offgas treatment system is functioning.

NOTE

When placing the Offgas Treatment System in the charcoal bypass mode, the alarm setpoints for the Station HVAC Exhaust and the Post-Treatment Offgas radiation monitors may be calculated to account for the increased fractions of short-lived noble gases. The noble gas release fractions shall be based either on actual measured values or on design basis noble gas concentration fractions (30-minute delay) in the primary coolant offgas.

3.7 Ventilation Exhaust Treatment

3.7.1 Ventilation Exhaust Treatment System - Operation and Surveillance Requirements

OPERATION REQUIREMENT

---

The VENTILATION EXHAUST TREATMENT SYSTEM (VETS) shall be used to reduce radioactive materials in gaseous waste prior to their discharge when the projected doses due to gaseous effluent releases to areas at and beyond the SITE BOUNDARY (see Figure 3.1-1) would exceed 0.3 mrem to any organ in a 31-day period. This requirement applies at all times other than when the VETS is undergoing routine maintenance.

REMEDIAL REQUIREMENT:

- a. With gaseous waste being discharged without treatment and in excess of the above limit, prepare and submit to the Regional Administrator of the Regional Office of the NRC within 30 days a Special Report that includes the following information:
  1. Explanation of why gaseous radwaste was being discharged without treatment, identification of any inoperable equipment or subsystems, and the reason for the inoperability,
  2. Action(s) taken to restore the inoperable equipment to OPERABLE status, and
  3. Summary description of action(s) taken to prevent a recurrence.

SURVEILLANCE REQUIREMENTS

---

- 3.7.1.1 Doses due to gaseous releases from the site shall be projected at least once per 31 days in accordance with this manual when the ventilation exhaust treatment system is not in use. The projected doses resulting from such releases will be calculated using Section 3.7.2 methodology. If the dose impact resulting from the projected 31-day release exceeds 0.3 mrem and the VETS is capable of reducing the projected impact to less than 0.3 mrem, the VETS shall be used.
- 3.7.1.2 The installed VENTILATION EXHAUST TREATMENT SYSTEM shall be considered OPERABLE by meeting the Operation Requirements of Sections 3.4, 3.5.1, and 3.5.2.

### 3.7.2 Gaseous Effluent Dose Projection Calculations

The 31 day projected dose shall be calculated using the following equation

$$D_{pj} = (D_j * p) + D_{aj} \quad (15)$$

where:

$D_{pj}$  = the 31 day projected dose by organ j.

$D_j$  = sum of dose for all valid release points for the release period (usually quarter) by organ j.

p = the projection factor which is the results of 31 divided by the number of days from the start of the quarter to the end of the release.

$D_{aj}$  = additional anticipated dose for gaseous release by organ j and quarter of release.

### 3.8 Effluent Monitor Setpoint Calculations

Gaseous effluent Process Radiation Monitor (PRM) alarm setpoints shall be calculated to ensure that the instantaneous dose rate in unrestricted areas due to noble gases released do not exceed 500 mrem/year to the total body and 3000 mrem/year to the skin. The initial setpoints were calculated using the BWR/GALE code radionuclide mix obtained for CPS; when the actual radionuclide mix can be determined, it will be used for setpoint calculations. The PRM setpoints are based on the instantaneous noble gas dose rates and are applied at the point of which the effluent enters an unrestricted area.

Due to PRM limitations, non-noble gas setpoints will not be implemented to demonstrate compliance with Section 3.4.1(b). Compliance with the organ dose rate limitation is demonstrated during performance of sampling and analysis activities required by Table 3.4-1.

Both total body and skin dose setpoints will be calculated and the more restrictive limit applied to the respective PRM. The actual setpoint used may be lower than the restrictive limit since the two release points will be partitioned such that their sum does not exceed 100 percent of the restrictive limit. The percentages used to partition the release points could vary at plant discretion to accommodate plant operational conditions. In no case will the combined releases due to variations in the PRM setpoints result in effluent limits being exceeded.

3.8.1 Total Body Dose Rate Setpoint

The fraction of the total gaseous radioactivity in each gaseous effluent release path  $j$  for each noble gas radionuclide  $i$  shall be determined using the following relationship:

$$f_{ij} = C_{ij} / (\sum_i C_{ij}), \text{ dimensionless} \quad (16)$$

where

$C_{ij}$  = The measured concentration of identified noble gas radionuclide  $i$  in gaseous effluent release path  $j$ ,  $\mu\text{Ci/cc}$

The maximum acceptable release rate of all noble gases in release path  $j$  to comply with Section 3.4.1 is calculated by using the equation:

$$Q_{Tj} = 500 \cdot F_j / [(\overline{X/Q})_j \sum_i (K_i f_{ij})], \mu\text{Ci/sec} \quad (17)$$

where

$Q_{Tj}$  = The maximum acceptable release rate of all noble gases in release path  $j$ ,  $\mu\text{Ci/sec}$

$F_j$  = Total dose rate allocation factor assigned to release path  $j$  (varying between 0.0 and 1.0), dimensionless

500 = Total body dose rate limit specified in Section 3.4.1(a),  $\text{mrem/year}$

$(\overline{X/Q})_j$  = The highest calculated average relative concentration of release path  $j$  at the site boundary

$K_i$  = The total body dose factor due to gamma emissions of noble gas radionuclide  $i$  as listed in Table B-1 of Regulatory Guide 1.109 and Table 3.4-2 of this manual,  $\text{mrem/yr per } \mu\text{Ci/m}^3$

$f_{ij}$  = The fraction as defined by equation (16), dimensionless

The total maximum acceptable concentration setpoint of noble gas radionuclides in release path  $j$  is calculated using the following equation:

$$C_{Tj} = Q_{Tj} / R_j, \mu\text{Ci/cc} \quad (18)$$

where

$C_{Tj}$  = The total maximum acceptable concentration setpoint of all noble gases in release path  $j$ ,  $\mu\text{Ci/cc}$



$Q_{Tj}$  = The maximum acceptable release rate of all noble gases in release path  $j$  determined from equation (19),  $\mu\text{Ci}/\text{sec}$

$R_j$  = The effluent release rate of release point  $j$ ,  $\text{cc}/\text{sec}$

### 3.8.2 Skin Dose Rate Setpoint

To ensure compliance with the section 3.4.1(a) skin dose rate limit, PRM setpoints shall be calculated using the methodology presented in Section 3.8.1 and by substituting the following equation for equation (16):

$$Q_{Sj} = (3000 * F_j) / [(\overline{X/Q})_j * \sum_i (L_i + 1.1M_i) * f_{ij}], \mu\text{Ci}/\text{sec} \quad (19)$$

where

$Q_{Sj}$  = The maximum acceptable release rate of all noble gases in release path  $j$ ,  $\mu\text{Ci}/\text{sec}$

$F_j$  = Total dose rate allocation factor assigned to release path  $j$  (varying between 0.0 and 1.0), dimensionless

3000 = Skin dose rate limit specified in Section 3.4.1(a),  $\text{mrem}/\text{year}$

$(\overline{X/Q})_j$  = The highest calculated average relative concentration of release path  $j$  at the site boundary

$L_i$  = The skin dose factor due to gamma emissions for each identified noble gas radionuclide  $i$ ,  $\text{mrem}/\text{yr}$  per  $\mu\text{Ci}/\text{m}^3$ , as listed in Table 3.4-2 of this manual.

1.1 = An air dose to skin dose equivalent conversion factor,  $\text{mrem}/\text{mrad}$

$M_i$  = The air dose factor due to gamma emissions for each identified noble gas radionuclide  $i$ ,  $\text{mrad}/\text{yr}$  per  $\mu\text{Ci}/\text{m}^3$ , as listed in Table 3.4-2 of this manual

$f_{ij}$  = The fraction defined by equation (16)

The calculated total body and skin maximum acceptable concentration setpoints are compared and the more restrictive setpoint used. A safety factor may also be applied to the concentration setpoint calculated by equation (17) to compensate for statistical fluctuations and measurement errors.

3.9 Radioactive Gaseous Monitoring Instrumentation

3.9.1 Offgas Radiation Monitoring Instrumentation - Operation and Surveillance Requirements

OPERATION REQUIREMENT

---

The offgas radiation monitoring instrumentation channels shown in Table 3.9.1-1 shall be OPERABLE, with their alarm/trip setpoints within the specified limits. This requirement applies during operation of the main condenser air ejector(s).

REMEDIAL REQUIREMENT:

- a. With a radiation monitoring instrumentation channel alarm/trip setpoint exceeding the value shown in Table 3.9.1-1, immediately suspend the release of radioactive gaseous effluents monitored by the affected channel, or declare the channel inoperable.
- b. With less than the minimum number of radioactive gaseous effluent monitoring instrumentation channels OPERABLE, comply with the REMEDIAL REQUIREMENT specified in Table 3.9.1-1. Restore the inoperable instrumentation to OPERABLE status within 30 days and, if unsuccessful, explain in the next Radioactive Effluent Release Report pursuant to Technical Specification 5.6.3 why this inoperability was not corrected in a timely manner.

SURVEILLANCE REQUIREMENTS

---

- 3.9.1.1 Each of the above required radiation monitoring instrumentation channels shall be demonstrated OPERABLE by the performance of the CHANNEL CHECK, SOURCE CHECK, CHANNEL FUNCTIONAL TEST and CHANNEL CALIBRATION at the frequencies shown in Table 3.9.1-2.

TABLE 3.9.1-1

OFFGAS RADIATION MONITORING INSTRUMENTATION

<u>INSTRUMENTATION</u>	<u>MINIMUM CHANNELS OPERABLE (e)</u>	<u>ALARM/TRIP SETPOINT</u>	<u>REMEDIAL REQUIREMENT</u>
1. Pre-treatment Off-gas PRM - Noble Gas Activity Monitor 1RIX-PR034	1 <sup>d</sup>	$\leq 50 \mu\text{Ci/cc}^{\text{a,b}}$	5
2. Post-treatment Off-gas PRM 1RIX-PR035/41			
a. High-Range Noble Gas Activity Monitor Providing Alarm and Automatic Termination of Release (Ch 7)	1 <sup>d</sup>	$\leq 7.06 \mu\text{Ci/cc}^{\text{c}}$	6
b. Effluent System Flow Rate Measuring Device 1N66-R620	1	NA	7
c. Sample Flow Rate Measuring Device (Ch 15)	1	NA	7

TABLE 3.9.1-1 (Continued)

OFFGAS RADIATION MONITORING INSTRUMENTATIONTABLE NOTATIONS

- a Alarm only.
- b Radioactivity concentration expected at the monitor location is a noble gas mix with a 2.9-minute decay.
- c Radioactivity concentration expected at the monitor location is a noble gas mix released from the off-gas treatment system.
- d Channel OPERABILITY shall include the capability of the MCR ARPR LAN to provide the alarm status of the applicable radiation monitor channel(s).
- e When a channel is placed in an inoperable status solely for performance of required Surveillances (source checks, sampling) entry into associated Remedial Requirements may be delayed for up to one hour.

REMEDIAL REQUIREMENTREMEDIAL  
REQUIREMENT

5

- a. If the communication link with the MCR ARPR LAN is inoperable,
  1. Perform a CHANNEL CHECK using local monitor indication within 8 hours and at least once per 8 hours thereafter, and
  2. Locally check for TREND alarm within 2 hours and at least once per 2 hours thereafter. (Note: This requirement is to provide sample indication to initiate Tech Spec Surveillance Requirement 3.7.5.1.)
  3. Restore communication for the applicable channel(s) within the next 30 days, and if unsuccessful, prepare and submit to the Regional Administrator of the Regional Office of the NRC within the next 10 days a Special Report outlining the cause of the communication failure or malfunction and the action taken to restore the inoperable equipment to OPERABLE status.

TABLE 3.9.1-1 (Continued)

OFFGAS RADIATION MONITORING INSTRUMENTATIONTABLE NOTATIONS

b. With the Pre-treatment Off-gas PRM - Noble Gas Activity Monitor otherwise inoperable, gases from the main condenser off-gas treatment system may be released to the environment provided:

1. The off-gas treatment system is not bypassed, except for filtration system by-pass during plant start-ups and

NOTE: The following step ensures compliance with Technical Specification Surveillance Requirement 3.7.5.1

2. Perform grab samples every 4 hours until the monitor is returned to OPERABLE status.

REMEDIAL  
REQUIREMENT

6

a. With the MCR ARPR LAN inoperable,

1. Perform a CHANNEL CHECK using local monitor indication within 8 hours and at least once per 8 hours thereafter, and
2. Restore the MCR ARPR LAN to OPERABLE status for the applicable channel(s) within the next 30 days, and if unsuccessful, prepare and submit to the Regional Administrator of the Regional Office of the NRC within the next 10 days a Special Report outlining the cause of the MCR ARPR LAN failure or malfunction and the action taken to restore the inoperable equipment to OPERABLE status.

TABLE 3.9.1-1 (Continued)

OFFGAS RADIATION MONITORING INSTRUMENTATION

TABLE NOTATIONS

- b. With the Post-treatment Off-gas PRM High Range Noble Gas Activity Monitor otherwise inoperable, effluent releases via this pathway may continue provided grab samples are taken at least once per 8 hours, and a noble gas gamma isotopic analysis performed within 24 hours.

REMEDIAL  
REQUIREMENT

7

With the number of channels OPERABLE less than required by the minimum channels OPERABLE requirement, effluent releases via this pathway may continue provided the flow rate is estimated at least once per 8 hours.

TABLE 3.9.1-2

OFFGAS RADIATION MONITORING INSTRUMENTATION SURVEILLANCE REQUIREMENTS

<u>INSTRUMENTATION</u>	<u>CHANNEL CHECK</u>	<u>SOURCE CHECK</u>	<u>CHANNEL FUNCTIONAL TEST</u>	<u>CHANNEL CALIBRATION</u>
1. Pre-Treatment Off-gas PRM-Noble Gas Activity Monitor	S <sup>(3)</sup>	M	Q(1)	R(2)
2. Post-Treatment Off- gas PRM				
a. High Range Noble Gas Activity Monitor Providing Alarm and Automatic Termination of Release	S <sup>(3)</sup>	W	Q(1)	R24(2) <sup>a</sup>
b. Effluent System Flow-Rate Measuring Device	D	NA	Q	R
c. Sample Flow-Rate Measuring Device	S	NA	Q	R24

TABLE 3.9.1-2 (Continued)

OFFGAS RADIATION MONITORING  
INSTRUMENTATION SURVEILLANCE REQUIREMENTS

TABLE NOTATION

- a Automatic isolation of valve 1N66-F060 shall be demonstrated during the CHANNEL CALIBRATION.
- (1) The CHANNEL FUNCTIONAL TEST shall also demonstrate that the MCR ARPR LAN responds with annunciation and event display to each of the following conditions:
1. Instrument indicates measured levels above the alarm/trip (HIGH) setpoint.
  2. Detector failure (LOW FAIL, HI FAIL).
  3. Sample flow failure (EXTERNAL FAIL).
  4. Instrument not set in normal operate mode (CALIBRATE, MAINTENANCE, or STANDBY).
- (2) The initial CHANNEL CALIBRATION shall be performed using one or more of the reference standards certified by the National Institute of Standards and Technology (NIST) or using standards that have been obtained from suppliers that participate in measurement assurance activities with NIST. These standards shall permit calibrating the system over its intended energy range and measurement range. Subsequent CHANNEL CALIBRATION shall be performed using the initial radioactive standards or other standards of equivalent quality or radioactive sources that have been related to the initial calibration.
- (3) The CHANNEL CHECK performed from the MCR ARPR LAN also verifies communication.



3.9.2 Radioactive Gaseous Effluent Monitoring Instrumentation  
- Operation and Surveillance Requirements

OPERATION REQUIREMENT

---

The radioactive gaseous effluent monitoring instrumentation channels shown in Table 3.9.2-1 shall be OPERABLE with their alarm/trip setpoints set to ensure that the limits of Section 3.4.1 and Technical Specification 3.7.5 are not exceeded. The alarm/trip setpoints of these channels shall be determined and adjusted in accordance with the methodology and parameters in this manual. This requirement applies as shown in Table 3.9.2-1.

REMEDIAL REQUIREMENT:

- a. With a radioactive gaseous effluent monitoring instrumentation channel alarm/trip setpoint less conservative than required by the above requirement, immediately suspend the release of radioactive gaseous effluents monitored by the affected channel, or declare the channel inoperable.
- b. With less than the minimum number of radioactive gaseous effluent monitoring instrumentation channels OPERABLE, comply with the REMEDIAL REQUIREMENT specified in Table 3.9.2-1. Restore the inoperable instrumentation to OPERABLE status within 30 days and, if unsuccessful, explain in the next Radioactive Effluent Release Report pursuant to Technical Specification 5.6.3 why this inoperability was not corrected in a timely manner.

SURVEILLANCE REQUIREMENTS

---

- 3.9.2.1 Each radioactive gaseous effluent monitoring instrumentation channel shall be demonstrated OPERABLE by performance of the CHANNEL CHECK, SOURCE CHECK, CHANNEL CALIBRATION and CHANNEL FUNCTIONAL TEST operations at the frequencies shown in Table 3.9.2-2.

TABLE 3.9.2-1  
RADIOACTIVE GASEOUS EFFLUENT MONITORING INSTRUMENTATION  
 MINIMUM

<u>INSTRUMENT</u>	<u>CHANNELS OPERABLE (g)</u>	<u>APPLICABILITY</u>	<u>REMEDIAL REQUIREMENT</u>
1. Station HVAC Exhaust PRM ORIX-PR001/2			
a. High-Range Noble Gas Activity Monitor (Ch 7)	1 <sup>c</sup>	a	8
b. Low-Range Noble Gas Activity Monitor (Ch 5)	1 <sup>c</sup>	a	8
c. Iodine Sampler <sup>(d)</sup>	1	a	9
d. Particulate Sampler <sup>(d)</sup>	1	a	9
e. Sample Flow-Rate Measuring Device (Ch 15)	1	a	10
2. Standby Gas Treatment System Exhaust PRM ORIX-PR003/4			
a. High-Range Noble Gas Activity Monitor (Ch 9)	1 <sup>c</sup>	b	8
b. Low-Range Noble Gas Activity Monitor (Ch 6)	1 <sup>c</sup>	b	8
c. Iodine Sampler <sup>d</sup>	1	b	9
d. Particulate Sampler <sup>d</sup>	1	b	9
e. Sample Flow-Rate Measuring Device (Ch 15)	1	b	10
3. Station HVAC Exhaust AXM ORIX-PR012			
a. High-Range Noble Gas Activity Monitor (Ch 3)	1	e	11
b. Intermediate-Range Noble Gas Activity Monitor (Ch 4)	1	e	11
c. Sample Flow-Rate Measuring Device OFI-PR012B	1	e	11
4. Standby Gas Treatment System Exhaust AXM ORIX-PR008			
a. High-Range Noble Gas Activity Monitor (Ch 3)	1	e	11
b. Intermediate-Range Noble Gas Activity Monitor (Ch 4)	1	e	11
c. Sample Flow-Rate Measuring Device OFI-PR008B	1	e	11
5. Station HVAC Effluent System Flow-Rate Measuring Device OUIX-PR051 Ch 6	1	a	10
6. SGTS Effluent System Flow-Rate Measuring Device OUIX-PR051 Ch 1	1	f	10

TABLE 3.9.2-1 (Continued)  
RADIOACTIVE GASEOUS EFFLUENT MONITORING INSTRUMENTATION  
TABLE NOTATIONS

- a Operable and inservice at all times.
- b Available and in service when standby gas treatment system is in standby or operation.
- c Channel OPERABILITY shall include the capability of the MCR ARPR LAN to provide the alarm status of the applicable radiation monitor channel(s).
- d Filter media (particulate collection patch for particulates and charcoal cartridge for iodines) in place with an operating sample pump constitutes an operable iodine/particulate sampler.
- e Operable and in standby/service modes 1, 2, and 3 only
- f When standby gas treatment system is in operation.
- g When a channel is placed in an inoperable status solely for performance of required surveillances (source checks, sampling) entry into associated Remedial Requirements may be delayed for up to one hour.

REMEDIAL REQUIREMENT

REMEDIAL  
 REQUIREMENT  
 8

- a. If communication using the alternative terminals is inoperable, perform a CHANNEL CHECK using local monitor indication within 8 hours and at least once per 8 hours thereafter.
- b. With the noble gas activity monitor channel(s) otherwise inoperable, effluent releases via this pathway may continue provided grab samples are taken at least once per 8 hours and analyzed for gross noble gas activity within 24 hours.

REMEDIAL  
 REQUIREMENT  
 9

With the number of channels OPERABLE less than required by the minimum channels OPERABLE requirement, effluent releases via this pathway may continue provided that, within 4 hours after the channel has been declared inoperable, samples required by Table 3.4-1 are continuously collected with auxiliary sampling equipment.

REMEDIAL  
 REQUIREMENT  
 10

With the number of channels OPERABLE less than required by the minimum channels OPERABLE requirement, effluent releases via this pathway may continue provided the flow rate is estimated at least once per 4 hours. Flow instruments OFIVG004 or OFIVG104 may be used to estimate SGTS flow.

REMEDIAL  
 REQUIREMENT  
 11

- With the number of OPERABLE Channels less than required by the Minimum Channels OPERABLE requirement, either restore the inoperable channel(s) to OPERABLE status within 72 hours, or:
- a. Initiate the preplanned alternate method of monitoring the appropriate parameter(s).
  - b. Instrument inoperability does not preclude changing mode.

TABLE 3.9.2-2  
 RADIOACTIVE GASEOUS EFFLUENT MONITORING INSTRUMENTATION SURVEILLANCE REQUIREMENTS

<u>INSTRUMENT</u>	<u>CHANNEL CHECK</u>	<u>SOURCE CHECK</u>	<u>CHANNEL CALIBRATION</u>	<u>CHANNEL FUNCTIONAL TEST</u>
1. Station HVAC Exhaust PRM				
a. High-Range Noble Gas Activity Monitor	S (3)	M	R (2)	Q (1)
b. Low-Range Noble Gas Activity Monitor	S (3)	M	R (2)	Q (1)
c. Iodine Sampler	W	NA	NA	NA
d. Particulate Sampler	W	NA	NA	NA
e. Sample Flow Rate Measuring Device	S	NA	R	Q
f. Effluent System Flow Rate Measuring Device	S	NA	R	Q
2. Standby Gas Treatment System Exhaust PRM				
a. High-Range Noble Gas Activity Monitor	S (3)	NA	R (2)	Q (1)
b. Low-Range Noble Gas Activity Monitor	S (3)	M	R (2)	Q (1)
c. Iodine Sampler	W	NA	NA	NA
d. Particulate Sampler	W	NA	NA	NA
e. Sample Flow Rate Measuring Device	S	NA	R	Q
f. Effluent System Flow Rate Measuring Device	S	NA	R	Q
3. Station HVAC Exhaust AXM				
a. High-Range Noble Gas Activity Monitor	S (3)	M	R (2)	NA
b. Intermediate-Range Noble Gas Activity Monitor	S (3)	M	R (2)	NA
c. Sample Flow Rate Measuring Device	*	NA	R	NA
4. Standby Gas Treatment System Exhaust AXM				
a. High-Range Noble Gas Activity Monitor	S (3)	M	R (2)	NA
b. Intermediate-Range Noble Gas Activity Monitor	S (3)	M	R (2)	NA
c. Sample Flow Rate Measuring Device	*	NA	R	NA
d. Automatic Operation <sup>(4)</sup>	NA	NA	NA	NA
5. Inservice Calibrations on Station HVAC Exhaust and Standby Gas Treatment System Exhaust PRMs	NA	NA	A <sup>(a,b)</sup>	NA

\* Shiftly when in operation with the pump running.

TABLE 3.9.2-2 (Continued)RADIOACTIVE GASEOUS EFFLUENT MONITORING INSTRUMENTATION  
SURVEILLANCE REQUIREMENTSTABLE NOTATIONS

- a Per Regulatory Guide 1.21, compare the PRM readings with grab sample results for the noble gas and particulate/iodine channels. Modify the channel calibrations as necessary to ensure monitor readings are related to the concentration or release rates of nuclides in the monitored path.
- b Not applicable if the activity in the sample stream is not high enough to provide a statistically relevant comparison.
- (1) The CHANNEL FUNCTIONAL TEST shall also demonstrate that the MCR ARPR LAN responds with annunciation and event display to each of the following conditions:
1. Instrument indicates measured levels above the alarm (HIGH) setpoint.
  2. Detector failure (LOW FAIL, HI FAIL).
  3. Sample flow failure (EXTERNAL FAIL).
  4. Instrument not set in normal operate mode (CALIBRATE, MAINTENANCE, or STANDBY).
- (2) The initial CHANNEL CALIBRATION shall be performed using one or more of the reference standards certified by the National Institute of Standards and Technology (NIST) or using standards that have been obtained from suppliers that participate in measurement assurance activities with NIST. These standards shall permit calibrating the system over its intended range of energy and measurement range. Subsequent CHANNEL CALIBRATION shall be performed using the initial radioactive standards or other standards of equivalent quality or radioactive sources that have been related to the initial calibration.
- (3) The CHANNEL CHECK performed from the MCR ARPR LAN also verifies communication.
- (4) Verify the SGTS AXM automatically starts upon initiation of DIV I SGTS and remains in service following shutdown of DIV I SGTS. Periodicity = 24 months

FIGURE 3.1-1  
CPS SITE BOUNDARY FOR GASEOUS EFFLUENTS

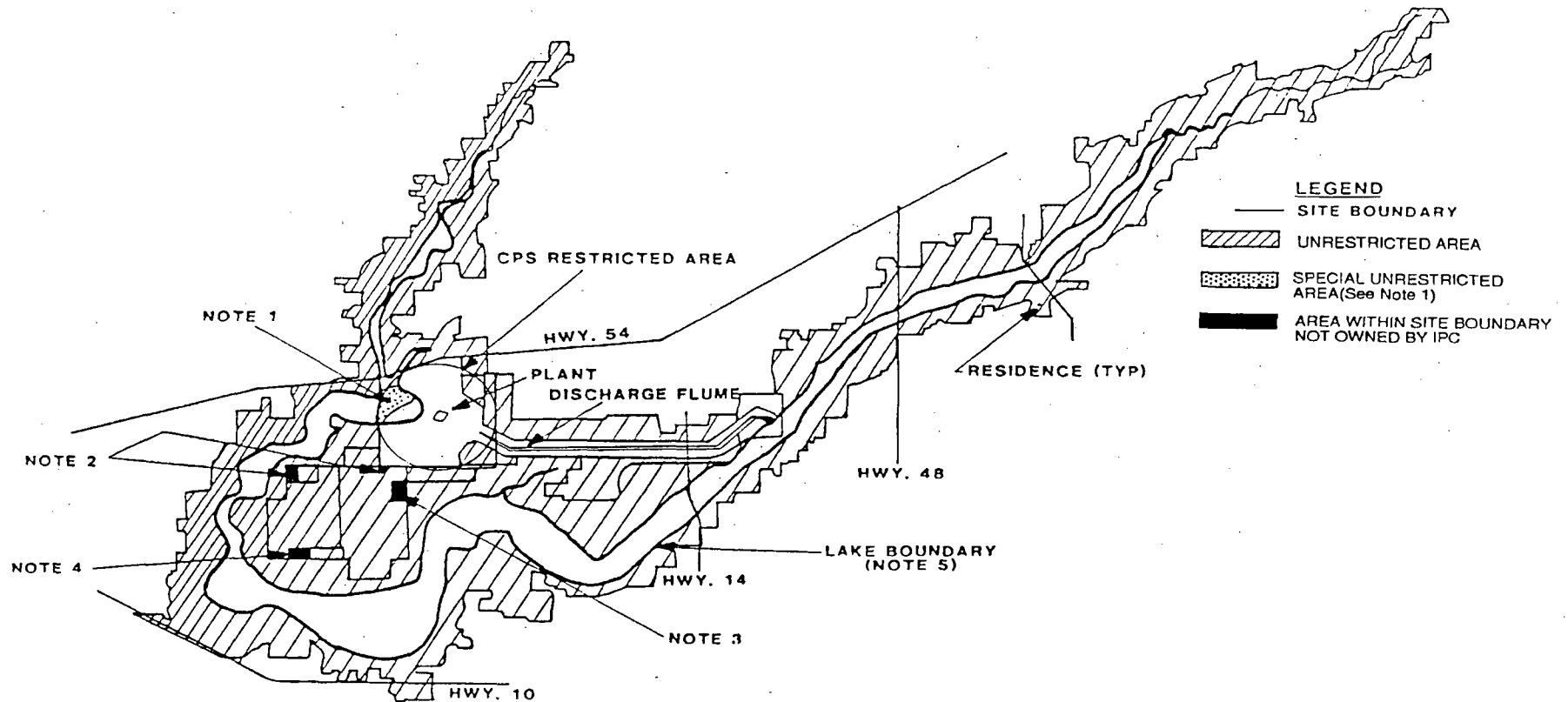

NOTES

1. The area in the lake between the buoys and the exclusion area boundary is unrestricted at this time. But will be controlled if plant effluent conditions warrant closure.
2. Land parcel not owned by AmerGen, includes residences.
3. Land parcel not owned by AmerGen, oil company pipeline pumping station.
4. Land parcel not owned by AmerGen, agricultural use.
5. The lake shoreline is approximately 690 ft. MSL elevation line.

FIGURE 3.3-1

MAIN CONDENSER OFF-GAS TREATMENT SYSTEM

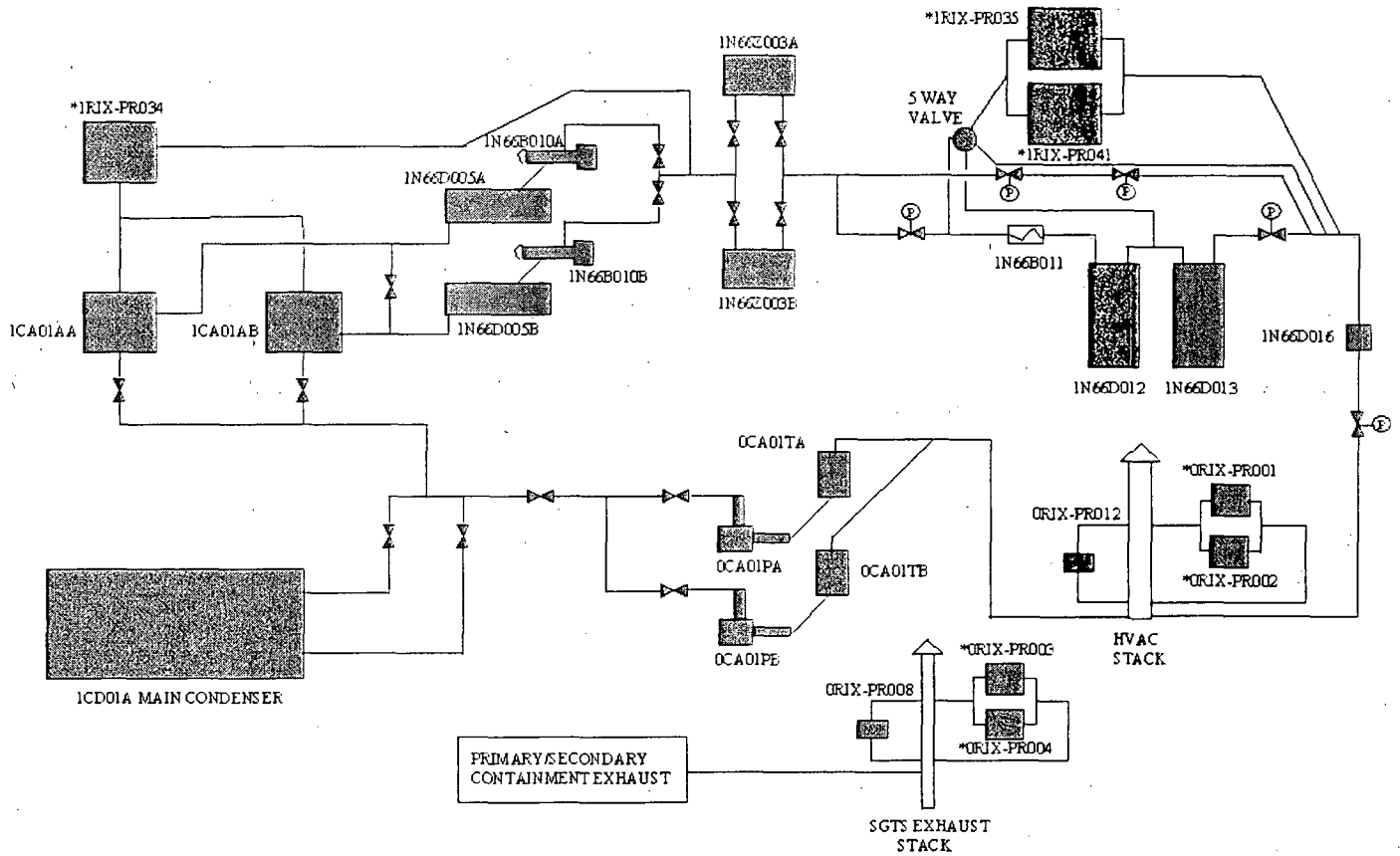

\*Monitors required by Sections 3.9.1 and 3.9.2

1CD01A Main Condenser	0CA01TA CV Separator Tank A	1N66B010B Cooler Condenser B	1N66D013 Charcoal Adsorber	1RIX-PR035 Off-Gas Post Treatment PRM
1CA01AA Steam Jet Air Ejector A	0CA01TB CV Separator Tank B	1N66Z003A Desiccant Dryer A	1N66D016 HEPA Filter	1RIX-PR041 Off-Gas Post Treatment PRM
1CA01AB Steam Jet Air Ejector B	1N66D005A Recombiner A	1N66Z003B Desiccant Dryer B	ORIX-PR001 HVAC Stack PRM #1	ORIX-PR003 Standby Gas Treatment PRM
0CA01PA Condenser Vacuum (CV) Pump A	1N66D005B Recombiner B	1N66B011 Gas Cooler	ORIX-PR002 HVAC Stack PRM #2	ORIX-PR004 Standby Gas Treatment PRM
0CA01PB CV Pump B	1N66B010A Cooler Condenser A	1N66D012 Charcoal Adsorber	1RIX-PR034 Off-Gas Pretreatment PRM	ORIX-PR012 HVAC Stack AXM
				ORIX-PR008 Standby Gas Treatment AXM

TABLE 3.5-1

 INHALATION DOSE FACTORS FOR INFANT - (DFA<sub>i</sub>)<sub>a</sub>  
 (mrem per pCi inhaled)

NUCLIDE	BONE	LIVER	T.BODY	THYROID	KIDNEY	LUNG	GI-LLI
H-3	NO DATA	4.62E-07	4.62E-07	4.62E-07	4.62E-07	4.62E-07	4.62E-07
P-32	1.45E-03	8.03E-05	5.53E-05	NO DATA	NO DATA	NO DATA	1.15E-05
CR-51	NO DATA	NO DATA	6.39E-08	4.11E-08	9.45E-09	9.17E-06	2.55E-07
MN-54	NO DATA	1.81E-05	3.56E-06	NO DATA	3.56E-06	7.14E-04	5.04E-06
FE-55	1.41E-05	8.39E-06	2.38E-06	NO DATA	NO DATA	6.21E-05	7.82E-07
FE-59	9.69E-06	1.68E-05	6.77E-06	NO DATA	NO DATA	7.25E-04	1.77E-05
CO-58	NO DATA	8.71E-07	1.30E-06	NO DATA	NO DATA	5.55E-04	7.95E-06
CO-60	NO DATA	5.73E-06	8.41E-06	NO DATA	NO DATA	3.22E-03	2.28E-05
NI-63	2.42E-04	1.46E-05	8.29E-06	NO DATA	NO DATA	1.49E-04	1.73E-06
ZN-65	1.38E-05	4.47E-05	2.22E-05	NO DATA	2.32E-05	4.62E-04	3.67E-05
RB-86	NO DATA	1.36E-04	6.30E-05	NO DATA	NO DATA	NO DATA	2.17E-06
SR-89	2.84E-04	NO DATA	8.15E-06	NO DATA	NO DATA	1.45E-03	4.57E-05
SR-90	2.92E-02	NO DATA	1.85E-03	NO DATA	NO DATA	8.03E-03	9.36E-05
Y-90	2.35E-06	NO DATA	6.30E-08	NO DATA	NO DATA	1.92E-04	7.43E-05
Y-91	4.20E-04	NO DATA	1.12E-05	NO DATA	NO DATA	1.75E-03	5.02E-05
ZR-95	8.24E-05	1.99E-05	1.45E-05	NO DATA	2.22E-05	1.25E-03	1.55E-05
NB-95	1.12E-05	4.59E-06	2.70E-06	NO DATA	3.37E-06	3.42E-04	9.05E-06
MO-99	NO DATA	1.18E-07	2.31E-08	NO DATA	1.89E-07	9.63E-05	3.48E-05
TC-99m	9.98E-13	2.06E-12	2.66E-11	NO DATA	2.22E-11	5.79E-07	1.45E-06
RU-103	1.44E-06	NO DATA	4.85E-07	NO DATA	3.03E-06	3.94E-04	1.15E-05
RU-106	6.20E-05	NO DATA	7.70E-06	NO DATA	7.61E-05	8.26E-03	1.17E-04
AG-110m	7.13E-06	5.16E-06	3.57E-06	NO DATA	7.80E-06	2.62E-03	2.36E-05
TE-125m	3.40E-06	1.42E-06	4.70E-07	1.16E-06	NO DATA	3.19E-04	9.22E-06
TE-127m	1.19E-05	4.93E-06	1.48E-06	3.48E-06	2.68E-05	9.37E-04	1.95E-05
TE-129m	1.01E-05	4.35E-06	1.59E-06	3.91E-06	2.27E-05	1.20E-03	4.93E-05
I-130	4.54E-06	9.91E-06	3.98E-06	1.14E-03	1.09E-05	NO DATA	1.42E-06
I-131	2.71E-05	3.17E-05	1.40E-05	1.06E-02	3.70E-05	NO DATA	7.56E-07
I-132	1.21E-06	2.53E-06	8.99E-07	1.21E-04	2.82E-06	NO DATA	1.36E-06
I-133	9.46E-06	1.37E-05	4.00E-06	2.54E-03	1.60E-05	NO DATA	1.54E-06
I-134	6.58E-07	1.34E-06	4.75E-07	3.18E-05	1.49E-06	NO DATA	9.21E-07
I-135	2.76E-06	5.43E-06	1.98E-06	4.97E-04	6.05E-06	NO DATA	1.31E-06
CS-134	2.83E-04	5.02E-04	5.32E-05	NO DATA	1.36E-04	5.69E-05	9.53E-07
CS-136	3.45E-05	9.61E-05	3.78E-05	NO DATA	4.03E-05	8.40E-06	1.02E-06
CS-137	3.92E-04	4.37E-04	3.25E-05	NO DATA	1.23E-04	5.09E-05	9.53E-07
BA-140	4.00E-05	4.00E-08	2.07E-06	NO DATA	9.59E-09	1.14E-03	2.74E-05
CE-141	1.98E-05	1.19E-05	1.42E-06	NO DATA	3.75E-06	3.69E-04	1.54E-05
CE-144	2.28E-03	8.65E-04	1.26E-04	NO DATA	3.84E-04	7.03E-03	1.06E-04
PR-143	1.00E-05	3.74E-06	4.99E-07	NO DATA	1.41E-06	3.09E-04	2.66E-05
ND-147	5.67E-06	5.81E-06	3.57E-07	NO DATA	2.25E-06	2.30E-04	2.23E-05



TABLE 3.5-2

 INHALATION DOSE FACTORS FOR CHILD - (DFA<sub>i</sub>)<sub>a</sub>  
 (mrem per pCi inhaled)

NUCLIDE	BONE	LIVER	T.BODY	THYROID	KIDNEY	LUNG	GI-LLI
H-3	NO DATA	3.04E-07	3.04E-07	3.04E-07	3.04E-07	3.04E-07	3.04E-07
P-32	7.04E-04	3.09E-05	2.67E-05	NO DATA	NO DATA	NO DATA	1.14E-05
CR-51	NO DATA	NO DATA	4.17E-08	2.31E-08	6.57E-09	4.59E-06	2.93E-07
MN-54	NO DATA	1.16E-05	2.57E-06	NO DATA	2.71E-06	4.26E-04	6.19E-06
FE-55	1.28E-05	6.80E-06	2.10E-06	NO DATA	NO DATA	3.00E-05	7.75E-07
FE-59	5.59E-06	9.04E-06	4.51E-06	NO DATA	NO DATA	3.43E-04	1.91E-05
CO-58	NO DATA	4.79E-07	8.55E-07	NO DATA	NO DATA	2.99E-04	9.29E-06
CO-60	NO DATA	3.55E-06	6.12E-06	NO DATA	NO DATA	1.91E-03	2.60E-05
NI-63	2.22E-04	1.25E-05	7.56E-06	NO DATA	NO DATA	7.43E-05	1.71E-06
ZN-65	1.15E-05	3.06E-05	1.90E-05	NO DATA	1.93E-05	2.69E-04	4.41E-06
RB-86	NO DATA	5.36E-05	3.09E-05	NO DATA	NO DATA	NO DATA	2.16E-06
SR-89	1.62E-04	NO DATA	4.66E-06	NO DATA	NO DATA	5.83E-04	4.52E-05
SR-90	2.73E-02	NO DATA	1.74E-03	NO DATA	NO DATA	3.99E-03	9.28E-05
Y-90	1.11E-06	NO DATA	2.99E-08	NO DATA	NO DATA	7.07E-05	7.24E-05
Y-91	2.47E-04	NO DATA	6.59E-06	NO DATA	NO DATA	7.10E-04	4.97E-05
ZR-95	5.13E-05	1.13E-05	1.00E-05	NO DATA	1.61E-05	6.03E-04	1.65E-05
NB-95	6.35E-06	2.48E-06	1.77E-06	NO DATA	2.33E-06	1.66E-04	1.00E-05
MO-99	NO DATA	4.66E-08	1.15E-08	NO DATA	1.06E-07	3.66E-05	3.42E-05
TC-99m	4.81E-13	9.41E-13	1.56E-11	NO DATA	1.37E-11	2.57E-07	1.30E-06
RU-103	7.55E-07	NO DATA	2.90E-07	NO DATA	1.90E-06	1.79E-04	1.21E-05
RU-106	3.68E-05	NO DATA	4.57E-06	NO DATA	4.97E-05	3.87E-03	1.16E-04
AG-110m	4.56E-06	3.08E-06	2.47E-06	NO DATA	5.74E-06	1.48E-03	2.71E-05
TE-125m	1.82E-06	6.29E-07	2.47E-07	5.20E-07	NO DATA	1.29E-04	9.13E-06
TE-127m	6.72E-06	2.31E-06	8.18E-07	1.64E-06	1.72E-05	4.00E-04	1.93E-05
TE-129m	5.19E-06	1.85E-06	8.22E-07	1.71E-06	1.36E-05	4.76E-04	4.91E-05
I-130	2.21E-06	4.43E-06	2.28E-06	4.99E-04	6.61E-06	NO DATA	1.38E-06
I-131	1.30E-05	1.30E-05	7.37E-06	4.39E-03	2.13E-05	NO DATA	7.68E-07
I-132	5.72E-07	1.10E-06	5.07E-07	5.23E-05	1.69E-06	NO DATA	8.65E-07
I-133	4.48E-06	5.49E-06	2.08E-06	1.04E-03	9.13E-06	NO DATA	1.48E-06
I-134	3.17E-07	5.84E-07	2.69E-07	1.37E-05	8.92E-07	NO DATA	2.58E-07
I-135	1.33E-06	2.36E-06	1.12E-06	2.14E-04	3.62E-06	NO DATA	1.20E-06
CS-134	1.76E-04	2.74E-04	6.07E-05	NO DATA	8.93E-05	3.27E-05	1.04E-06
CS-136	1.76E-05	4.62E-05	3.14E-05	NO DATA	2.58E-05	3.93E-06	1.13E-06
CS-137	2.45E-04	2.23E-04	3.47E-05	NO DATA	7.63E-05	2.81E-05	9.78E-07
BA-140	2.00E-05	1.75E-08	1.17E-06	NO DATA	5.71E-09	4.71E-04	2.75E-05
CE-141	1.06E-05	5.28E-06	7.83E-07	NO DATA	2.31E-06	1.47E-04	1.53E-05
CE-144	1.83E-03	5.72E-04	9.77E-05	NO DATA	3.17E-04	3.23E-03	1.05E-04
PR-143	4.99E-06	1.50E-06	2.47E-07	NO DATA	8.11E-07	1.17E-04	2.63E-05
ND-147	2.92E-06	2.36E-06	1.84E-07	NO DATA	1.30E-06	8.87E-05	2.22E-05

TABLE 3.5-3

 INHALATION DOSE FACTORS FOR TEEN -  $(DFA_i)_a$   
 (mrem per pCi inhaled)

NUCLIDE	BONE	LIVER	T.BODY	THYROID	KIDNEY	LUNG	GI-LLI
H-3	NO DATA	1.59E-07	1.59E-07	1.59E-07	1.59E-07	1.59E-07	1.59E-07
P-32	2.36E-04	1.37E-05	8.95E-06	NO DATA	NO DATA	NO DATA	1.16E-05
CR-51	NO DATA	NO DATA	1.69E-08	9.37E-09	3.84E-09	2.62E-06	3.75E-07
MN-54	NO DATA	6.39E-06	1.05E-06	NO DATA	1.59E-06	2.48E-04	8.35E-06
FE-55	4.18E-06	2.98E-06	6.93E-07	NO DATA	NO DATA	1.55E-05	7.99E-07
FE-59	1.99E-06	4.62E-06	1.79E-06	NO DATA	NO DATA	1.91E-04	2.23E-05
CO-58	NO DATA	2.59E-07	3.47E-07	NO DATA	NO DATA	1.68E-04	1.19E-05
CO-60	NO DATA	1.89E-06	2.48E-06	NO DATA	NO DATA	1.09E-03	3.24E-05
NI-63	7.25E-05	5.43E-06	2.47E-06	NO DATA	NO DATA	3.84E-05	1.77E-06
ZN-65	4.82E-06	1.67E-05	7.80E-06	NO DATA	1.08E-05	1.55E-04	5.83E-06
RB-86	NO DATA	2.38E-05	1.05E-05	NO DATA	NO DATA	NO DATA	2.21E-06
SR-89	5.43E-05	NO DATA	1.56E-06	NO DATA	NO DATA	3.02E-04	4.64E-05
SR-90	1.35E-02	NO DATA	8.35E-04	NO DATA	NO DATA	2.06E-03	9.56E-05
Y-90	3.73E-07	NO DATA	1.00E-08	NO DATA	NO DATA	3.66E-05	6.99E-05
Y-91	8.26E-05	NO DATA	2.21E-06	NO DATA	NO DATA	3.67E-04	5.11E-05
ZR-95	1.82E-05	5.73E-06	3.94E-06	NO DATA	8.42E-06	3.36E-04	1.86E-05
NB-95	2.32E-06	1.29E-06	7.08E-07	NO DATA	1.25E-06	9.39E-05	1.21E-05
MO-99	NO DATA	2.11E-08	4.03E-09	NO DATA	5.14E-08	1.92E-05	3.36E-05
TC-99m	1.73E-13	4.83E-13	6.24E-12	NO DATA	7.20E-12	1.44E-07	7.66E-07
RU-103	2.63E-07	NO DATA	1.12E-07	NO DATA	9.29E-07	9.79E-05	1.36E-05
RU-106	1.23E-05	NO DATA	1.55E-06	NO DATA	2.38E-05	2.01E-03	1.20E-04
AG-110m	1.73E-06	1.64E-06	9.99E-07	NO DATA	3.13E-06	8.44E-04	3.41E-05
TE-125m	6.10E-07	2.80E-07	8.34E-08	1.75E-07	NO DATA	6.70E-05	9.38E-06
TE-127m	2.25E-06	1.02E-06	2.73E-07	5.48E-07	8.17E-06	2.07E-04	1.99E-05
TE-129m	1.74E-06	8.23E-07	2.81E-07	5.72E-07	6.49E-06	2.47E-04	5.06E-05
I-130	7.80E-07	2.24E-06	8.96E-07	1.86E-04	3.44E-06	NO DATA	1.14E-06
I-131	4.43E-06	6.14E-06	3.30E-06	1.83E-03	1.05E-05	NO DATA	8.11E-07
I-132	1.99E-07	5.47E-07	1.97E-07	1.89E-05	8.65E-07	NO DATA	1.59E-07
I-133	1.52E-06	2.56E-06	7.78E-07	3.65E-04	4.49E-06	NO DATA	1.29E-06
I-134	1.11E-07	2.90E-07	1.05E-07	4.94E-06	4.58E-07	NO DATA	2.55E-09
I-135	4.62E-07	1.18E-06	4.36E-07	7.76E-05	1.86E-06	NO DATA	8.69E-07
CS-134	6.28E-05	1.41E-04	6.86E-05	NO DATA	4.69E-05	1.83E-05	1.22E-06
CS-136	6.44E-06	2.42E-05	1.71E-05	NO DATA	1.38E-05	2.22E-06	1.36E-06
CS-137	8.38E-05	1.06E-04	3.89E-05	NO DATA	3.80E-05	1.51E-05	1.06E-06
BA-140	6.84E-06	8.38E-09	4.40E-07	NO DATA	2.85E-09	2.54E-04	2.86E-05
CE-141	3.55E-06	2.37E-06	2.71E-07	NO DATA	1.11E-06	7.67E-05	1.58E-05
CE-144	6.11E-04	2.53E-04	3.28E-05	NO DATA	1.51E-04	1.67E-03	1.08E-04
PR-143	1.67E-06	6.64E-07	8.28E-08	NO DATA	3.86E-07	6.04E-05	2.67E-05
ND-147	9.83E-07	1.07E-06	6.41E-08	NO DATA	6.28E-07	4.65E-05	2.28E-05

TABLE 3.5-4

 INHALATION DOSE FACTORS FOR ADULT - (DFA<sub>i</sub>)<sub>a</sub>  
 (mrem per pCi inhaled)

NUCLIDE	BONE	LIVER	T.BODY	THYROID	KIDNEY	LUNG	GI-LLI
H-3	NO DATA	1.58E-07	1.58E-07	1.58E-07	1.58E-07	1.58E-07	1.58E-07
P-32	1.65E-04	9.64E-06	6.26E-06	NO DATA	NO DATA	NO DATA	1.08E-05
CR-51	NO DATA	NO DATA	1.25E-08	7.44E-09	2.85E-09	1.80E-06	4.15E-07
MN-54	NO DATA	4.95E-06	7.87E-07	NO DATA	1.23E-06	1.75E-04	9.67E-06
FE-55	3.07E-06	2.12E-06	4.93E-07	NO DATA	NO DATA	9.01E-06	7.54E-07
FE-59	1.47E-06	3.47E-06	1.32E-06	NO DATA	NO DATA	1.27E-04	2.35E-05
CO-58	NO DATA	1.98E-07	2.59E-07	NO DATA	NO DATA	1.16E-04	1.33E-05
CO-60	NO DATA	1.44E-06	1.85E-06	NO DATA	NO DATA	7.46E-04	3.56E-05
NI-63	5.40E-05	3.93E-06	1.81E-06	NO DATA	NO DATA	2.23E-05	1.67E-06
ZN-65	4.05E-06	1.29E-05	5.82E-06	NO DATA	8.62E-06	1.08E-04	6.68E-06
RB-86	NO DATA	1.69E-05	7.37E-06	NO DATA	NO DATA	NO DATA	2.08E-06
SR-89	3.80E-05	NO DATA	1.09E-06	NO DATA	NO DATA	1.75E-04	4.37E-05
SR-90	1.24E-02	NO DATA	7.62E-04	NO DATA	NO DATA	1.20E-03	9.02E-05
Y-90	2.61E-07	NO DATA	7.01E-09	NO DATA	NO DATA	2.12E-05	6.32E-05
Y-91	5.78E-05	NO DATA	1.55E-06	NO DATA	NO DATA	2.13E-04	4.81E-05
ZR-95	1.34E-05	4.30E-06	2.91E-06	NO DATA	6.77E-06	2.21E-04	1.88E-05
NB-95	1.76E-06	9.77E-07	5.26E-07	NO DATA	9.67E-07	6.31E-05	1.30E-05
MO-99	NO DATA	1.51E-08	2.87E-09	NO DATA	3.64E-08	1.14E-05	3.10E-05
TC-99m	1.29E-13	3.64E-13	4.63E-12	NO DATA	5.52E-12	9.55E-08	5.20E-07
RU-103	1.91E-07	NO DATA	8.23E-08	NO DATA	7.29E-07	6.31E-05	1.38E-05
RU-106	8.64E-06	NO DATA	1.09E-06	NO DATA	1.67E-05	1.17E-03	1.14E-04
AG-110m	1.35E-06	1.25E-06	7.43E-07	NO DATA	2.46E-06	5.79E-04	3.78E-05
TE-125m	4.27E-07	1.98E-07	5.84E-08	1.31E-07	1.55E-06	3.92E-05	8.83E-06
TE-127m	1.58E-06	7.21E-07	1.96E-07	4.11E-07	5.72E-06	1.20E-04	1.87E-05
TE-129m	1.22E-06	5.84E-07	1.98E-07	4.30E-07	4.57E-06	1.45E-04	4.79E-05
I-130	5.72E-07	1.68E-06	6.60E-07	1.42E-04	2.61E-06	NO DATA	9.61E-07
I-131	3.15E-06	4.47E-06	2.56E-06	1.49E-03	7.66E-06	NO DATA	7.85E-07
I-132	1.45E-07	4.07E-07	1.45E-07	1.43E-05	6.48E-07	NO DATA	5.08E-08
I-133	1.08E-06	1.85E-06	5.65E-07	2.69E-04	3.23E-06	NO DATA	1.11E-06
I-134	8.05E-08	2.16E-07	7.69E-08	3.73E-06	3.44E-07	NO DATA	1.26E-10
I-135	3.35E-07	8.73E-07	3.21E-07	5.60E-05	1.39E-06	NO DATA	6.56E-07
CS-134	4.66E-05	1.06E-04	9.10E-05	NO DATA	3.59E-05	1.22E-05	1.30E-06
CS-136	4.88E-06	1.83E-05	1.38E-05	NO DATA	1.07E-05	1.50E-06	1.46E-06
CS-137	5.98E-05	7.76E-05	5.35E-05	NO DATA	2.78E-05	9.40E-06	1.05E-06
BA-140	4.88E-06	6.13E-09	3.21E-07	NO DATA	2.09E-09	1.59E-04	2.73E-05
CE-141	2.49E-06	1.69E-06	1.91E-07	NO DATA	7.83E-07	4.52E-05	1.50E-05
CE-144	4.29E-04	1.79E-04	2.30E-05	NO DATA	1.06E-04	9.72E-04	1.02E-04
PR-143	1.17E-06	4.69E-07	5.80E-08	NO DATA	2.70E-07	3.51E-05	2.50E-05
ND-147	6.59E-07	7.62E-07	4.56E-08	NO DATA	4.45E-07	2.76E-05	2.16E-05

TABLE 3.5-5

GROUND PLANE DOSE FACTORS - DFG<sub>1</sub>  
(mrem/hr per pCi/m<sup>2</sup>)

<u>ELEMENT</u>	<u>TOTAL BODY</u>	<u>SKIN</u>
H-3	0.0	0.0
P-32	0.0	0.0
Cr-51	2.20E-10	2.60E-10
Mn-54	5.80E-09	6.80E-09
Fe-55	0.0	0.0
Fe-59	8.00E-09	9.40E-09
Co-58	7.00E-09	8.20E-09
Co-60	1.70E-08	2.00E-08
Ni-63	0.0	0.0
Zn-65	4.00E-09	4.60E-09
Rb-86	6.30E-10	7.20E-10
Sr-89	5.60E-13	6.50E-13
Y-90	2.20E-12	2.60E-12
Y-91	2.40E-11	2.70E-11
Zr-95	5.00E-09	5.80E-09
Nb-95	5.10E-09	6.00E-09
Mo-99	1.90E-09	2.20E-09
Tc-99m	9.60E-10	1.10E-09
Ru-103	3.60E-09	4.20E-09
Ru-106	1.50E-09	1.80E-09
Ag-110m	1.80E-08	2.10E-08
Te-125m	3.50E-11	4.80E-11
Te-127m	1.10E-12	1.30E-12
Te-129m	7.70E-10	9.00E-10
I-130	1.40E-08	1.70E-08
I-131	2.80E-09	3.40E-09
I-132	1.70E-08	2.00E-08
I-133	3.70E-09	4.50E-09
I-134	1.60E-08	1.90E-08
I-135	1.20E-08	1.40E-08
Cs-134	1.20E-08	1.40E-08
Cs-136	1.50E-08	1.70E-08
Cs-137	4.20E-09	4.90E-09
Ba-140	2.10E-09	2.40E-09
Ce-141	5.50E-10	6.20E-10
Ce-144	3.20E-10	3.70E-10
Pr-143	0.0	0.0
Nd-147	1.00E-09	1.20E-09

TABLE 3.5-6

 INGESTION DOSE FACTORS FOR INFANT -  $(DFL_i)_a$   
 (mrem per pCi ingested)

NUCLIDE	BONE	LIVER	T.BODY	THYROID	KIDNEY	LUNG	GI-LLI
H-3	NO DATA	3.08E-07	3.08E-07	3.08E-07	3.08E-07	3.08E-07	3.08E-07
P-32	1.70E-03	1.00E-04	6.59E-05	NO DATA	NO DATA	NO DATA	2.30E-05
CR-51	NO DATA	NO DATA	1.41E-08	9.20E-09	2.01E-09	1.79E-08	4.11E-07
MN-54	NO DATA	1.99E-05	4.51E-06	NO DATA	4.41E-06	NO DATA	7.31E-06
FE-55	1.39E-05	8.98E-06	2.40E-06	NO DATA	NO DATA	4.39E-06	1.14E-06
FE-59	3.08E-05	5.38E-05	2.12E-05	NO DATA	NO DATA	1.59E-05	2.57E-05
CO-58	NO DATA	3.60E-06	8.98E-06	NO DATA	NO DATA	NO DATA	8.97E-06
CO-60	NO DATA	1.08E-05	2.55E-05	NO DATA	NO DATA	NO DATA	2.57E-05
NI-63	6.34E-04	3.92E-05	2.20E-05	NO DATA	NO DATA	NO DATA	1.95E-06
ZN-65	1.84E-05	6.31E-05	2.91E-05	NO DATA	3.06E-05	NO DATA	5.33E-05
RB-86	NO DATA	1.70E-04	8.40E-05	NO DATA	NO DATA	NO DATA	4.34E-06
SR-89	2.51E-03	NO DATA	7.20E-05	NO DATA	NO DATA	NO DATA	5.16E-05
SR-90	1.85E-02	NO DATA	4.71E-03	NO DATA	NO DATA	NO DATA	2.31E-04
Y-90	8.69E-08	NO DATA	2.33E-09	NO DATA	NO DATA	NO DATA	1.20E-04
Y-91	1.13E-06	NO DATA	3.01E-08	NO DATA	NO DATA	NO DATA	8.10E-05
ZR-95	2.06E-07	5.02E-08	3.56E-08	NO DATA	5.41E-08	NO DATA	2.50E-05
NB-95	4.20E-08	1.73E-08	1.00E-08	NO DATA	1.24E-08	NO DATA	1.46E-05
MO-99	NO DATA	3.40E-05	6.63E-06	NO DATA	5.08E-05	NO DATA	1.12E-05
TC-99m	1.92E-09	3.96E-09	5.10E-08	NO DATA	4.26E-08	2.07E-09	1.15E-06
RU-103	1.48E-06	NO DATA	4.95E-07	NO DATA	3.08E-06	NO DATA	1.80E-05
RU-106	2.41E-05	NO DATA	3.01E-06	NO DATA	2.85E-05	NO DATA	1.83E-04
AG-110m	9.96E-07	7.27E-07	4.81E-07	NO DATA	1.04E-06	NO DATA	3.77E-05
TE-125m	2.33E-05	7.79E-06	3.15E-06	7.84E-06	NO DATA	NO DATA	1.11E-05
TE-127m	5.85E-05	1.94E-05	7.08E-06	1.69E-05	1.44E-04	NO DATA	2.36E-05
TE-129m	1.00E-04	3.43E-05	1.54E-05	3.84E-05	2.50E-04	NO DATA	5.97E-05
I-130	6.00E-06	1.32E-05	5.30E-06	1.48E-03	1.45E-05	NO DATA	2.83E-06
I-131	3.59E-05	4.23E-05	1.86E-05	1.39E-02	4.94E-05	NO DATA	1.51E-06
I-132	1.66E-06	3.37E-06	1.20E-06	1.58E-04	3.76E-06	NO DATA	2.73E-06
I-133	1.25E-05	1.82E-05	5.33E-06	3.31E-03	2.14E-05	NO DATA	3.08E-06
I-134	8.69E-07	1.78E-06	6.33E-07	4.15E-05	1.99E-06	NO DATA	1.84E-06
I-135	3.64E-06	7.24E-06	2.64E-06	6.49E-04	8.07E-06	NO DATA	2.62E-06
CS-134	3.77E-04	7.03E-04	7.10E-05	NO DATA	1.81E-04	7.42E-05	1.91E-06
CS-136	4.59E-05	1.35E-04	5.04E-05	NO DATA	5.38E-05	1.10E-05	2.05E-06
CS-137	5.22E-04	6.11E-04	4.33E-05	NO DATA	1.64E-04	6.64E-05	1.91E-06
BA-140	1.71E-04	1.71E-07	8.81E-06	NO DATA	4.06E-08	1.05E-07	4.20E-05
CE-141	7.87E-08	4.80E-08	5.65E-09	NO DATA	1.48E-08	NO DATA	2.48E-05
CE-144	2.98E-06	1.22E-06	1.67E-07	NO DATA	4.93E-07	NO DATA	1.71E-04
PR-143	8.13E-08	3.04E-08	4.03E-09	NO DATA	1.13E-08	NO DATA	4.29E-05
ND-147	5.53E-08	5.68E-08	3.48E-09	NO DATA	2.19E-08	NO DATA	3.60E-05

TABLE 3.5-7

 INGESTION DOSE FACTORS FOR CHILD -  $(DFL_i)_c$   
 (mrem per pCi ingested)

NUCLIDE	BONE	LIVER	T.BODY	THYROID	KIDNEY	LUNG	GI-LLI
H-3	NO DATA	2.03E-07	2.03E-07	2.03E-07	2.03E-07	2.03E-07	2.03E-07
P-32	8.25E-04	3.86E-05	3.18E-05	NO DATA	NO DATA	NO DATA	2.28E-05
CR-51	NO DATA	NO DATA	8.90E-09	4.94E-09	1.35E-09	9.02E-09	4.72E-07
MN-54	NO DATA	1.07E-05	2.85E-06	NO DATA	3.00E-06	NO DATA	8.98E-06
FE-55	1.15E-05	6.10E-06	1.89E-06	NO DATA	NO DATA	3.45E-06	1.13E-06
FE-59	1.65E-05	2.67E-05	1.33E-05	NO DATA	NO DATA	7.74E-06	2.78E-05
CO-58	NO DATA	1.80E-06	5.51E-06	NO DATA	NO DATA	NO DATA	1.05E-05
CO-60	NO DATA	5.29E-06	1.56E-05	NO DATA	NO DATA	NO DATA	2.93E-05
NI-63	5.38E-04	2.88E-05	1.83E-05	NO DATA	NO DATA	NO DATA	1.94E-06
ZN-65	1.37E-05	3.65E-05	2.27E-05	NO DATA	2.30E-05	NO DATA	6.41E-06
RB-86	NO DATA	6.70E-05	4.12E-05	NO DATA	NO DATA	NO DATA	4.31E-06
SR-89	1.32E-03	NO DATA	3.77E-05	NO DATA	NO DATA	NO DATA	5.11E-05
SR-90	1.70E-02	NO DATA	4.31E-03	NO DATA	NO DATA	NO DATA	2.29E-04
Y-90	4.11E-08	NO DATA	1.10E-09	NO DATA	NO DATA	NO DATA	1.17E-04
Y-91	6.02E-07	NO DATA	1.61E-08	NO DATA	NO DATA	NO DATA	8.02E-05
ZR-95	1.16E-07	2.55E-08	2.27E-08	NO DATA	3.65E-08	NO DATA	2.66E-05
NB-95	2.25E-08	8.76E-09	6.26E-09	NO DATA	8.23E-09	NO DATA	1.62E-05
MO-99	NO DATA	1.33E-05	3.29E-06	NO DATA	2.84E-05	NO DATA	1.10E-05
TC-99m	9.23E-10	1.81E-09	3.00E-08	NO DATA	2.63E-08	9.19E-10	1.03E-06
RU-103	7.31E-07	NO DATA	2.81E-07	NO DATA	1.84E-06	NO DATA	1.89E-05
RU-106	1.17E-05	NO DATA	1.46E-06	NO DATA	1.58E-05	NO DATA	1.82E-04
AG-110m	5.39E-07	3.64E-07	2.91E-07	NO DATA	6.78E-07	NO DATA	4.33E-05
TE-125m	1.14E-05	3.09E-06	1.52E-06	3.20E-06	NO DATA	NO DATA	1.10E-05
TE-127m	2.89E-05	7.78E-06	3.43E-06	6.91E-06	8.24E-05	NO DATA	2.34E-05
TE-129m	4.87E-05	1.36E-05	7.56E-06	1.57E-05	1.43E-04	NO DATA	5.94E-05
I-130	2.92E-06	5.90E-06	3.04E-06	6.50E-04	8.82E-06	NO DATA	2.76E-06
I-131	1.72E-05	1.73E-05	9.83E-06	5.72E-03	2.84E-05	NO DATA	1.54E-06
I-132	8.00E-07	1.47E-06	6.76E-07	6.82E-05	2.25E-06	NO DATA	1.73E-06
I-133	5.92E-06	7.32E-06	2.77E-06	1.36E-03	1.22E-05	NO DATA	2.95E-06
I-134	4.19E-07	7.78E-07	3.58E-07	1.79E-05	1.19E-06	NO DATA	5.16E-07
I-135	1.75E-06	3.15E-06	1.49E-06	2.79E-04	4.83E-06	NO DATA	2.40E-06
CS-134	2.34E-04	3.84E-04	8.10E-05	NO DATA	1.19E-04	4.27E-05	2.07E-06
CS-136	2.35E-05	6.46E-05	4.18E-05	NO DATA	3.44E-05	5.13E-06	2.27E-06
CS-137	3.27E-04	3.13E-04	4.62E-05	NO DATA	1.02E-04	3.67E-05	1.96E-06
BA-140	8.31E-05	7.28E-08	4.85E-06	NO DATA	2.37E-08	4.34E-08	4.21E-05
CE-141	8.97E-08	1.98E-08	2.94E-09	NO DATA	8.68E-09	NO DATA	2.47E-05
CE-144	2.08E-06	6.52E-07	1.11E-07	NO DATA	3.61E-07	NO DATA	1.70E-04
PR-143	3.93E-08	1.18E-08	1.95E-09	NO DATA	6.39E-09	NO DATA	4.24E-05
ND-147	2.79E-08	2.26E-08	1.75E-09	NO DATA	1.24E-08	NO DATA	3.58E-05

TABLE 3.5-8

 INGESTION DOSE FACTORS FOR TEEN - (DFL<sub>i</sub>)<sub>a</sub>  
 (mrem per pCi ingested)

NUCLIDE	BONE	LIVER	T.BODY	THYROID	KIDNEY	LUNG	GI-LLI
H-3	NO DATA	1.06E-07	1.06E-07	1.06E-07	1.06E-07	1.06E-07	1.06E-07
P-32	2.76E-04	1.71E-05	1.07E-05	NO DATA	NO DATA	NO DATA	2.32E-05
CR-51	NO DATA	NO DATA	3.60E-09	2.00E-09	7.89E-10	5.14E-09	6.05E-07
MN-54	NO DATA	5.90E-06	1.17E-06	NO DATA	1.76E-06	NO DATA	1.21E-05
FE-55	3.78E-06	2.68E-06	6.25E-07	NO DATA	NO DATA	1.70E-06	1.16E-06
FE-59	5.87E-06	1.37E-05	5.29E-06	NO DATA	NO DATA	4.32E-06	3.24E-05
CO-58	NO DATA	9.72E-07	2.24E-06	NO DATA	NO DATA	NO DATA	1.34E-05
CO-60	NO DATA	2.81E-06	6.33E-06	NO DATA	NO DATA	NO DATA	3.66E-05
NI-63	1.77E-04	1.25E-05	6.00E-06	NO DATA	NO DATA	NO DATA	1.99E-06
ZN-65	5.76E-06	2.00E-05	9.33E-06	NO DATA	1.28E-05	NO DATA	8.47E-06
RB-86	NO DATA	2.98E-05	1.40E-05	NO DATA	NO DATA	NO DATA	4.41E-06
SR-89	4.40E-04	NO DATA	1.26E-05	NO DATA	NO DATA	NO DATA	5.24E-05
SR-90	8.30E-03	NO DATA	2.05E-03	NO DATA	NO DATA	NO DATA	2.33E-04
Y-90	1.37E-08	NO DATA	3.69E-10	NO DATA	NO DATA	NO DATA	1.13E-04
Y-91	2.01E-07	NO DATA	5.39E-09	NO DATA	NO DATA	NO DATA	8.24E-05
ZR-95	4.12E-08	1.30E-08	8.94E-09	NO DATA	1.91E-08	NO DATA	3.00E-05
NB-95	8.22E-09	4.56E-09	2.51E-09	NO DATA	4.42E-09	NO DATA	1.95E-05
MO-99	NO DATA	6.03E-06	1.15E-06	NO DATA	1.38E-05	NO DATA	1.08E-05
TC-99m	3.32E-10	9.26E-10	1.20E-08	NO DATA	1.38E-08	5.14E-10	6.08E-07
RU-103	2.55E-07	NO DATA	1.09E-07	NO DATA	8.99E-07	NO DATA	2.13E-05
RU-106	3.92E-06	NO DATA	4.94E-07	NO DATA	7.56E-06	NO DATA	1.88E-04
AG-110m	2.05E-07	1.94E-07	1.18E-07	NO DATA	3.70E-07	NO DATA	5.45E-05
TE-125m	3.83E-06	1.38E-06	5.12E-07	1.07E-06	NO DATA	NO DATA	1.13E-05
TE-127m	9.67E-06	3.43E-06	1.15E-06	2.30E-06	3.92E-05	NO DATA	2.41E-05
TE-129m	1.63E-05	6.05E-06	2.58E-06	5.26E-06	6.82E-05	NO DATA	6.12E-05
I-130	1.03E-06	2.98E-06	1.19E-06	2.43E-04	4.59E-06	NO DATA	2.29E-06
I-131	5.85E-06	8.19E-06	4.40E-06	2.39E-03	1.41E-05	NO DATA	1.62E-06
I-132	2.79E-07	7.30E-07	2.62E-07	2.46E-05	1.15E-06	NO DATA	3.18E-07
I-133	2.01E-06	3.41E-06	1.04E-06	4.76E-04	5.98E-06	NO DATA	2.58E-06
I-134	1.46E-07	3.87E-07	1.39E-07	6.45E-06	6.10E-07	NO DATA	5.10E-09
I-135	6.10E-07	1.57E-06	5.82E-07	1.01E-04	2.48E-06	NO DATA	1.74E-06
CS-134	8.37E-05	1.97E-04	9.14E-05	NO DATA	6.26E-05	2.39E-05	2.45E-06
CS-136	8.59E-06	3.38E-05	2.27E-05	NO DATA	1.84E-05	2.90E-06	2.72E-06
CS-137	1.12E-04	1.49E-04	5.19E-05	NO DATA	5.07E-05	1.97E-05	2.12E-06
BA-140	2.84E-05	3.48E-08	1.83E-06	NO DATA	1.18E-08	2.34E-08	4.38E-05
CE-141	1.33E-08	8.88E-09	1.02E-09	NO DATA	4.18E-09	NO DATA	2.54E-05
CE-144	6.96E-07	2.88E-07	3.74E-08	NO DATA	1.72E-07	NO DATA	1.75E-04
PR-143	1.31E-08	5.23E-09	6.52E-10	NO DATA	3.04E-09	NO DATA	4.31E-05
ND-147	9.38E-09	1.02E-08	6.11E-10	NO DATA	5.99E-09	NO DATA	3.68E-05

TABLE 3.5-9

 INGESTION DOSE FACTORS FOR ADULT - (DFL<sub>i</sub>)<sub>a</sub>  
 (mrem per pCi ingested)

NUCLIDE	BONE	LIVER	T.BODY	THYROID	KIDNEY	LUNG	GI-LLI
H-3	NO DATA	1.05E-07	1.05E-07	1.05E-07	1.05E-07	1.05E-07	1.05E-07
P-32	1.93E-04	1.20E-05	7.46E-06	NO DATA	NO DATA	NO DATA	2.17E-05
CR-51	NO DATA	NO DATA	2.66E-09	1.59E-09	5.86E-10	3.53E-09	6.69E-07
MN-54	NO DATA	4.57E-06	8.72E-07	NO DATA	1.36E-06	NO DATA	1.40E-05
FE-55	2.75E-06	1.90E-06	4.43E-07	NO DATA	NO DATA	1.06E-06	1.09E-06
FE-59	4.34E-06	1.02E-05	3.91E-06	NO DATA	NO DATA	2.85E-06	3.40E-05
CO-58	NO DATA	7.45E-07	1.67E-06	NO DATA	NO DATA	NO DATA	1.51E-05
CO-60	NO DATA	2.14E-06	4.72E-06	NO DATA	NO DATA	NO DATA	4.02E-05
NI-63	1.30E-04	9.01E-06	4.36E-06	NO DATA	NO DATA	NO DATA	1.88E-06
ZN-65	4.84E-06	1.54E-05	6.96E-06	NO DATA	1.03E-05	NO DATA	9.70E-06
RB-86	NO DATA	2.11E-05	9.83E-06	NO DATA	NO DATA	NO DATA	4.16E-06
SR-89	3.08E-04	NO DATA	8.84E-06	NO DATA	NO DATA	NO DATA	4.94E-05
SR-90	7.58E-03	NO DATA	1.86E-03	NO DATA	NO DATA	NO DATA	2.19E-04
Y-90	9.62E-09	NO DATA	2.58E-10	NO DATA	NO DATA	NO DATA	1.02E-04
Y-91	1.41E-07	NO DATA	3.77E-09	NO DATA	NO DATA	NO DATA	7.76E-05
ZR-95	3.04E-08	9.75E-09	6.60E-09	NO DATA	1.53E-08	NO DATA	3.09E-05
NB-95	6.22E-09	3.46E-09	1.86E-09	NO DATA	3.42E-09	NO DATA	2.10E-05
MO-99	NO DATA	4.31E-06	8.20E-07	NO DATA	9.76E-06	NO DATA	9.99E-06
TC-99m	2.47E-10	6.98E-10	8.89E-09	NO DATA	1.06E-08	3.42E-10	4.13E-07
RU-103	1.85E-07	NO DATA	7.97E-08	NO DATA	7.06E-07	NO DATA	2.16E-05
RU-106	2.75E-06	NO DATA	3.48E-07	NO DATA	5.31E-06	NO DATA	1.78E-04
AG-110m	1.60E-07	1.48E-07	8.79E-08	NO DATA	2.91E-07	NO DATA	6.04E-05
TE-125m	2.68E-06	9.71E-07	3.59E-07	8.06E-07	1.09E-05	NO DATA	1.07E-05
TE-127m	6.77E-06	2.42E-06	8.25E-07	1.73E-06	2.75E-05	NO DATA	2.27E-05
TE-129m	1.15E-05	4.29E-06	1.82E-06	3.95E-06	4.80E-05	NO DATA	5.79E-05
I-130	7.56E-07	2.23E-06	8.80E-07	1.89E-04	3.48E-06	NO DATA	1.92E-06
I-131	4.16E-06	5.95E-06	3.41E-06	1.95E-03	1.02E-05	NO DATA	1.57E-06
I-132	2.03E-07	5.43E-07	1.90E-07	1.90E-05	8.65E-07	NO DATA	1.02E-07
I-133	1.42E-06	2.47E-06	7.53E-07	3.63E-04	4.31E-06	NO DATA	2.22E-06
I-134	1.06E-07	2.88E-07	1.03E-07	4.99E-06	4.58E-07	NO DATA	2.51E-10
I-135	4.43E-07	1.16E-06	4.28E-07	7.65E-05	1.86E-06	NO DATA	1.31E-06
CS-134	6.22E-05	1.48E-04	1.21E-04	NO DATA	4.79E-05	1.59E-05	2.59E-06
CS-136	6.51E-06	2.57E-05	1.85E-05	NO DATA	1.43E-05	1.96E-06	2.92E-06
CS-137	7.97E-05	1.09E-04	7.14E-05	NO DATA	3.70E-05	1.23E-05	2.11E-06
BA-140	2.03E-05	2.55E-08	1.33E-06	NO DATA	8.67E-09	1.46E-08	4.18E-05
CE-141	9.36E-09	6.33E-09	7.18E-10	NO DATA	2.94E-09	NO DATA	2.42E-05
CE-144	4.88E-07	2.04E-07	2.62E-08	NO DATA	1.21E-07	NO DATA	1.65E-04
PR-143	9.20E-09	3.69E-09	4.56E-10	NO DATA	2.13E-09	NO DATA	4.03E-05
ND-147	6.29E-09	7.27E-09	4.35E-10	NO DATA	4.25E-09	NO DATA	3.49E-05



TABLE 3.5-10

INPUT PARAMETERS FOR CALCULATING  $R_{ija}^C$ 

Parameter	Value	Table*
$Q_F$ (kg/day)	50 for cow 6 for goat	E-3
$U_{ap}$ (liters/yr) - Infant	330	E-5
- Child	330	E-5
- Teen	400	E-5
- Adult	310	E-5
$Y_p$ (kg/m <sup>2</sup> )	0.7	E-15
$Y_s$ (kg/m <sup>2</sup> )	2.0	E-15
$F_m$ (days/liter)	Each stable element for cow	E-1
	Each stable element for goat	E-2
$r$ (dimensionless)	1.0 for radioiodine	E-15
	0.2 for particulates	E-15
$t_f$ (seconds)	1.73E+05(2 days)	E-15
$t_h$ (seconds)	7.78E+06(90 days)	E-15
$f_s$ (dimensionless)	1.0 for cow	NUREG -
	1.0 for goat	0133
		Section
		5.3.1.3
$f_p$ (dimensionless)	1.0 for cow	NUREG -
	1.0 for goat	0133
		Section
		5.3.1.3

\*of Regulatory Guide 1.109 unless otherwise stated

TABLE 3.5-11

INPUT PARAMETERS FOR CALCULATING  $R_{ija}^M$ 

<u>Parameter</u>	<u>Value</u>	<u>Table*</u>
U <sub>ap</sub> (liters/yr) - Infant	0	E-5
- Child	41	E-5
- Teen	65	E-5
- Adult	110	E-5
F <sub>f</sub> (days/kg)	Each stable element	E-1
t <sub>s</sub> (seconds)	1.73E+06 (20 days)	E-15
t <sub>h</sub> (seconds)	7.78E+06 (90 days)	E-15
Y <sub>p</sub> (kg/m <sup>2</sup> )	0.7	E-15
Y <sub>s</sub> (kg/m <sup>2</sup> )	2.0	E-15
r(dimensionless)	1.0 for radioiodine	E-15
	0.2 for particulates	E-15
Q <sub>f</sub> (kg/day)	50	E-3

\*of Regulatory Guide 1.109

TABLE 3.5-12

INPUT PARAMETERS FOR CALCULATING  $R_{ija}^V$ 

<u>Parameter</u>	<u>Value</u>	<u>Table*</u>
$U_a^L$ (kg/yr) - Infant	0	E-5
- Child	26	E-5
- Teen	42	E-5
- Adult	64	E-5
$U_a^S$ (kg/yr) - Infant	0	E-5
- Child	520	E-5
- Teen	630	E-5
- Adult	520	E-5
$f_L$ (dimensionless)	1.0	E-15
$f_g$ (dimensionless)	0.76	E-15
$t_L$ (seconds)	8.60E+04 (1 day)	E-15
$t_h$ (seconds)	5.18E+06 (60 days)	E-15
$Y_v$ (kg/m <sup>2</sup> )	2.0	E-15

\*of Regulatory Guide 1.109

TABLE 3.5-13

INHALATION PATHWAY FACTORS -  $R_{ija}^I$  (INFANT)  
(mrem/yr per  $\mu\text{Ci}/\text{m}^3$ )

<u>ORGAN:</u> <u>ISOTOPE</u>	<u>BONE</u>	<u>LIVER</u>	<u>T.BODY</u>	<u>THYROID</u>	<u>KIDNEY</u>	<u>LUNG</u>	<u>GI-LLI</u>
H-3	NO DATA	6.47E+02	6.47E+02	6.47E+02	6.47E+02	6.47E+02	6.47E+02
P-32	2.03E+06	1.12E+05	7.74E+04	NO DATA	NO DATA	NO DATA	1.61E+04
CR-51	NO DATA	NO DATA	8.95E+01	5.75E+01	1.32E+01	1.28E+04	3.57E+02
MN-54	NO DATA	2.53E+04	4.98E+03	NO DATA	4.98E+03	1.00E+06	7.06E+03
FE-55	1.97E+04	1.17E+04	3.33E+03	NO DATA	NO DATA	8.69E+04	1.09E+03
FE-59	1.36E+04	2.35E+04	9.48E+03	NO DATA	NO DATA	1.02E+06	2.48E+04
CO-58	NO DATA	1.22E+03	1.82E+03	NO DATA	NO DATA	7.77E+05	1.11E+04
CO-60	NO DATA	8.02E+03	1.18E+04	NO DATA	NO DATA	4.51E+06	3.19E+04
NI-63	3.39E+05	2.04E+04	1.16E+04	NO DATA	NO DATA	2.09E+05	2.42E+03
ZN-65	1.93E+04	6.26E+04	3.11E+04	NO DATA	3.25E+04	6.47E+05	5.14E+04
RB-86	NO DATA	1.90E+05	8.82E+04	NO DATA	NO DATA	NO DATA	3.04E+03
SR-89	3.98E+05	NO DATA	1.14E+04	NO DATA	NO DATA	2.03E+06	6.40E+04
SR-90	4.09E+07	NO DATA	2.59E+06	NO DATA	NO DATA	1.12E+07	1.31E+05
Y-90	3.29E+03	NO DATA	8.82E+01	NO DATA	NO DATA	2.69E+05	1.04E+05
Y-91	5.88E+05	NO DATA	1.57E+04	NO DATA	NO DATA	2.45E+06	7.03E+04
ZR-95	1.15E+05	2.79E+04	2.03E+04	NO DATA	3.11E+04	1.75E+06	2.17E+04
NB-95	1.57E+04	6.43E+03	3.78E+03	NO DATA	4.72E+03	4.79E+05	1.27E+04
MO-99	NO DATA	1.65E+02	3.23E+01	NO DATA	2.65E+02	1.35E+05	4.87E+04
TC-99m	1.40E-03	2.88E-03	3.72E-02	NO DATA	3.11E-02	8.11E+02	2.03E+03
RU-103	2.02E+03	NO DATA	6.79E+02	NO DATA	4.24E+03	5.52E+05	1.61E+04
RU-106	8.68E+04	NO DATA	1.09E+04	NO DATA	1.07E+05	1.16E+07	1.64E+05
AG-110m	9.98E+03	7.22E+03	5.00E+03	NO DATA	1.09E+04	3.67E+06	3.30E+04
TE-125m	4.76E+03	1.99E+03	6.58E+02	1.62E+03	NO DATA	4.47E+05	1.29E+04
TE-127m	1.67E+04	6.90E+03	2.07E+03	4.87E+03	3.75E+04	1.31E+06	2.73E+04
TE-129m	1.41E+04	6.09E+03	2.23E+03	5.47E+03	3.18E+04	1.68E+06	6.90E+04
I-130	6.39E+03	1.39E+04	5.57E+03	1.60E+06	1.53E+04	NO DATA	1.99E+03
I-131	3.79E+04	4.44E+04	1.96E+04	1.48E+07	5.18E+04	NO DATA	1.06E+03
I-132	1.69E+03	3.54E+03	1.26E+03	1.69E+05	3.95E+03	NO DATA	1.90E+03
I-133	1.32E+04	1.92E+04	5.60E+03	3.56E+06	2.24E+04	NO DATA	2.16E+03
I-134	9.21E+02	1.88E+03	6.65E+02	4.45E+04	2.09E+03	NO DATA	1.29E+03
I-135	3.86E+03	7.60E+03	2.77E+03	6.96E+05	8.47E+03	NO DATA	1.83E+03
CS-134	3.96E+05	7.03E+05	7.45E+04	NO DATA	1.90E+05	7.97E+04	1.33E+03
CS-136	4.83E+04	1.35E+05	5.29E+04	NO DATA	5.64E+04	1.18E+04	1.43E+03
CS-137	5.49E+05	6.12E+05	4.55E+04	NO DATA	1.72E+05	7.13E+04	1.33E+03
BA-140	5.60E+04	5.60E+01	2.90E+03	NO DATA	1.34E+01	1.60E+06	3.84E+04
CE-141	2.77E+04	1.67E+04	1.99E+03	NO DATA	5.25E+03	5.17E+05	2.16E+04
CE-144	3.19E+06	1.21E+06	1.76E+05	NO DATA	5.38E+05	9.84E+06	1.48E+05
PR-143	1.40E+04	5.24E+03	6.99E+02	NO DATA	1.97E+03	4.33E+05	3.72E+04
ND-147	7.94E+03	8.13E+03	5.00E+02	NO DATA	3.15E+03	3.22E+05	3.12E+04

TABLE 3.5-14

 INHALATION PATHWAY FACTORS --  $R^1_{ija}$  (CHILD)  
 (mrem/yr per  $\mu\text{Ci}/\text{m}^3$ )

ORGAN: ISOTOPE	BONE	LIVER	T.BODY	THYROID	KIDNEY	LUNG	GI-LLI
H-3	NO DATA	1.12E+03	1.12E+03	1.12E+03	1.12E+03	1.12E+03	1.12E+03
P-32	2.60E+06	1.14E+05	9.87E+04	NO DATA	NO DATA	NO DATA	4.21E+04
CR-51	NO DATA	NO DATA	1.54E+02	8.54E+01	2.43E+01	1.70E+04	1.08E+03
MN-54	NO DATA	4.29E+04	9.51E+03	NO DATA	1.00E+04	1.58E+06	2.29E+04
FE-55	4.74E+04	2.52E+04	7.77E+03	NO DATA	NO DATA	1.11E+05	2.87E+03
FE-59	2.07E+04	3.34E+04	1.67E+04	NO DATA	NO DATA	1.27E+06	7.07E+04
CO-58	NO DATA	1.77E+03	3.16E+03	NO DATA	NO DATA	1.11E+06	3.44E+04
CO-60	NO DATA	1.31E+04	2.26E+04	NO DATA	NO DATA	7.07E+06	9.62E+04
NI-63	8.21E+05	4.63E+04	2.80E+04	NO DATA	NO DATA	2.75E+05	6.33E+03
ZN-65	4.26E+04	1.13E+05	7.03E+04	NO DATA	7.14E+04	9.95E+05	1.63E+04
RB-86	NO DATA	1.98E+05	1.14E+05	NO DATA	NO DATA	NO DATA	7.99E+03
SR-89	5.99E+05	NO DATA	1.72E+04	NO DATA	NO DATA	2.16E+06	1.67E+05
SR-90	1.01E+08	NO DATA	6.44E+06	NO DATA	NO DATA	1.48E+07	3.43E+05
Y-90	4.11E+03	NO DATA	1.11E+02	NO DATA	NO DATA	2.62E+05	2.66E+05
Y-91	9.14E+05	NO DATA	2.44E+04	NO DATA	NO DATA	2.63E+06	1.84E+05
ZR-95	1.90E+05	4.18E+04	3.70E+04	NO DATA	5.96E+04	2.23E+06	6.11E+04
NB-95	2.35E+04	9.18E+03	6.55E+03	NO DATA	8.62E+03	6.14E+05	3.70E+04
MO-99	NO DATA	1.72E+02	4.26E+01	NO DATA	3.92E+02	1.35E+05	1.27E+05
TC-99m	1.78E-03	3.48E-03	5.77E-02	NO DATA	5.07E-02	9.51E+02	4.81E+03
RU-103	2.79E+03	NO DATA	1.07E+03	NO DATA	7.03E+03	6.62E+05	4.48E+04
RU-106	1.36E+05	NO DATA	1.69E+04	NO DATA	1.84E+05	1.43E+07	4.29E+05
AG-110m	1.69E+04	1.14E+04	9.14E+03	NO DATA	2.12E+04	5.48E+06	1.00E+05
TE-125m	6.73E+03	2.33E+03	9.14E+02	1.92E+03	NO DATA	4.77E+05	3.38E+04
TE-127m	2.49E+04	8.55E+03	3.02E+03	6.07E+03	6.36E+04	1.48E+06	7.14E+04
TE-129m	1.92E+04	6.85E+03	3.04E+03	6.33E+03	5.03E+04	1.76E+06	1.82E+05
I-130	8.18E+03	1.64E+04	8.44E+03	1.85E+06	2.45E+04	NO DATA	5.11E+03
I-131	4.81E+04	4.81E+04	2.73E+04	1.62E+07	7.88E+04	NO DATA	2.84E+03
I-132	2.12E+03	4.07E+03	1.88E+03	1.94E+05	6.25E+03	NO DATA	3.20E+03
I-133	1.66E+04	2.03E+04	7.70E+03	3.85E+06	3.38E+04	NO DATA	5.48E+03
I-134	1.17E+03	2.16E+03	9.95E+02	5.07E+04	3.30E+03	NO DATA	9.54E+02
I-135	4.92E+03	8.73E+03	4.14E+03	7.92E+05	1.34E+04	NO DATA	4.44E+03
CS-134	6.51E+05	1.01E+06	2.25E+05	NO DATA	3.30E+05	1.21E+05	3.85E+03
CS-136	6.51E+04	1.71E+05	1.16E+05	NO DATA	9.55E+04	1.45E+04	4.18E+03
CS-137	9.70E+05	8.25E+05	1.28E+05	NO DATA	2.82E+05	1.04E+05	3.62E+03
BA-140	7.40E+04	6.48E+01	4.33E+03	NO DATA	2.11E+01	1.74E+06	1.02E+05
CE-141	3.92E+04	1.95E+05	2.90E+03	NO DATA	8.55E+03	5.44E+05	5.66E+04
CE-144	6.77E+06	2.12E+06	3.61E+05	NO DATA	1.17E+06	1.20E+07	3.89E+05
PR-143	1.85E+04	5.55E+03	9.14E+02	NO DATA	3.00E+03	4.33E+05	9.73E+04
ND-147	1.08E+04	8.73E+03	6.81E+02	NO DATA	4.81E+03	3.28E+05	8.21E+04

TABLE 3.5-15

 INHALATION PATHWAY FACTORS -  $R_{ija}^I$  (TEEN)  
 (mrem/yr per  $\mu\text{Ci}/\text{m}^3$ )

ORGAN: ISOTOPE	BONE	LIVER	T.BODY	THYROID	KIDNEY	LUNG	GI-LLI
H-3	NO DATA	1.27E+03	1.27E+03	1.27E+03	1.27E+03	1.27E+03	1.27E+03
P-32	1.89E+06	1.10E+05	7.16E+04	NO DATA	NO DATA	NO DATA	9.28E+04
CR-51	NO DATA	NO DATA	1.35E+02	7.50E+01	3.07E+01	2.10E+04	3.00E+03
MN-54	NO DATA	5.11E+04	8.40E+03	NO DATA	1.27E+04	1.98E+06	6.68E+04
FE-55	3.34E+04	2.38E+04	5.54E+03	NO DATA	NO DATA	1.24E+05	6.39E+03
FE-59	1.59E+04	3.70E+04	1.43E+04	NO DATA	NO DATA	1.53E+06	1.78E+05
CO-58	NO DATA	2.07E+03	2.78E+03	NO DATA	NO DATA	1.34E+06	9.52E+04
CO-60	NO DATA	1.51E+04	1.98E+04	NO DATA	NO DATA	8.72E+06	2.59E+05
NI-63	5.80E+05	4.34E+04	1.98E+04	NO DATA	NO DATA	3.07E+05	1.42E+04
ZN-65	3.86E+04	1.34E+05	6.24E+04	NO DATA	8.64E+04	1.24E+06	4.66E+04
RB-86	NO DATA	1.90E+05	8.40E+04	NO DATA	NO DATA	NO DATA	1.77E+04
SR-89	4.34E+05	NO DATA	1.25E+04	NO DATA	NO DATA	2.42E+06	3.71E+05
SR-90	1.08E+08	NO DATA	6.68E+06	NO DATA	NO DATA	1.65E+07	7.65E+05
Y-90	2.98E+03	NO DATA	8.00E+01	NO DATA	NO DATA	2.93E+05	5.59E+05
Y-91	6.61E+05	NO DATA	1.77E+04	NO DATA	NO DATA	2.94E+06	4.09E+05
ZR-95	1.46E+05	4.58E+04	3.15E+04	NO DATA	6.74E+04	2.69E+06	1.49E+05
NB-95	1.86E+04	1.03E+04	5.66E+03	NO DATA	1.00E+04	7.51E+05	9.68E+04
MO-99	NO DATA	1.69E+02	3.22E+01	NO DATA	4.11E+02	1.54E+05	2.69E+05
TC-99m	1.38E-03	3.86E-03	4.99E-02	NO DATA	5.76E-02	1.15E+03	6.13E+03
RU-103	2.10E+03	NO DATA	8.96E+02	NO DATA	7.43E+03	7.83E+05	1.09E+05
RU-106	9.84E+04	NO DATA	1.24E+04	NO DATA	1.90E+05	1.61E+07	9.60E+05
AG-110m	1.38E+04	1.31E+04	7.99E+03	NO DATA	2.50E+04	6.75E+06	2.73E+05
TE-125m	4.88E+03	2.24E+03	6.67E+02	1.40E+03	NO DATA	5.36E+05	7.50E+04
TE-127m	1.80E+04	8.16E+03	2.18E+03	4.38E+03	6.54E+04	1.66E+06	1.59E+05
TE-129m	1.39E+04	6.58E+03	2.25E+03	4.58E+03	5.19E+04	1.98E+06	4.05E+05
I-130	6.24E+03	1.78E+04	7.17E+03	1.49E+06	2.75E+04	NO DATA	9.12E+03
I-131	3.54E+04	4.91E+04	2.64E+04	1.46E+07	8.40E+04	NO DATA	6.49E+03
I-132	1.59E+03	4.38E+03	1.58E+03	1.51E+05	6.92E+03	NO DATA	1.27E+03
I-133	1.22E+04	2.05E+04	6.22E+03	2.92E+06	3.59E+04	NO DATA	1.03E+04
I-134	8.88E+02	2.32E+03	8.40E+02	3.95E+04	3.66E+03	NO DATA	2.04E+01
I-135	3.70E+03	9.44E+03	3.49E+03	6.21E+05	1.49E+04	NO DATA	6.95E+03
CS-134	5.02E+05	1.12E+06	5.49E+05	NO DATA	3.75E+05	1.46E+05	9.76E+03
CS-136	5.15E+04	1.94E+05	1.37E+05	NO DATA	1.10E+05	1.78E+04	1.09E+04
CS-137	6.70E+05	8.48E+05	3.11E+05	NO DATA	3.04E+05	1.21E+05	8.48E+03
BA-140	5.47E+04	6.70E+01	3.52E+03	NO DATA	2.28E+01	2.03E+06	2.29E+05
CE-141	2.84E+04	1.90E+04	2.17E+03	NO DATA	8.88E+03	6.14E+05	1.26E+05
CE-144	4.89E+06	2.02E+06	2.62E+05	NO DATA	1.21E+06	1.34E+07	8.64E+05
PR-143	1.34E+04	5.31E+03	6.62E+02	NO DATA	3.09E+03	4.83E+05	2.14E+05
ND-147	7.86E+03	8.56E+03	5.13E+02	NO DATA	5.02E+03	3.72E+05	1.82E+05

TABLE 3.5-16

 INHALATION PATHWAY FACTORS -  $R^1_{ija}$  (ADULT)  
 (mrem/yr per  $\mu\text{Ci}/\text{m}^3$ )

ORGAN: ISOTOPE	BONE	LIVER	T.BODY	THYROID	KIDNEY	LUNG	GI-LLI
H-3	NO DATA	1.26E+03	1.26E+03	1.26E+03	1.26E+03	1.26E+03	1.26E+03
P-32	1.32E+06	7.71E+04	5.01E+04	NO DATA	NO DATA	NO DATA	8.64E+04
CR-51	NO DATA	NO DATA	1.00E+02	5.95E+01	2.28E+01	1.44E+04	3.32E+03
MN-54	NO DATA	3.96E+04	6.30E+03	NO DATA	9.84E+03	1.40E+06	7.74E+04
FE-55	2.46E+04	1.70E+04	3.94E+03	NO DATA	NO DATA	7.21E+04	6.03E+03
FE-59	1.18E+04	2.78E+04	1.06E+04	NO DATA	NO DATA	1.02E+06	1.88E+05
CO-58	NO DATA	1.58E+03	2.07E+03	NO DATA	NO DATA	9.28E+05	1.06E+05
CO-60	NO DATA	1.15E+04	1.48E+04	NO DATA	NO DATA	5.97E+06	2.85E+05
NI-63	4.32E+05	3.14E+04	1.45E+04	NO DATA	NO DATA	1.78E+05	1.34E+04
ZN-65	3.24E+04	1.03E+05	4.66E+04	NO DATA	6.90E+04	8.64E+05	5.34E+04
RB-86	NO DATA	1.35E+05	5.90E+04	NO DATA	NO DATA	NO DATA	1.66E+04
SR-89	3.04E+05	NO DATA	8.72E+03	NO DATA	NO DATA	1.40E+06	3.50E+05
SR-90	9.92E+07	NO DATA	6.10E+06	NO DATA	NO DATA	9.60E+06	7.22E+05
Y-90	2.09E+03	NO DATA	5.61E+01	NO DATA	NO DATA	1.70E+05	5.06E+05
Y-91	4.62E+05	NO DATA	1.24E+04	NO DATA	NO DATA	1.70E+06	3.85E+05
ZR-95	1.07E+05	3.44E+04	2.33E+04	NO DATA	5.42E+04	1.77E+06	1.50E+05
NB-95	1.41E+04	7.82E+03	4.21E+03	NO DATA	7.74E+03	5.05E+05	1.04E+05
MO-99	NO DATA	1.21E+02	2.30E+01	NO DATA	2.91E+02	9.12E+04	2.48E+05
TC-99m	1.03E-03	2.91E-03	3.70E-02	NO DATA	4.42E-02	7.64E+02	4.16E+03
RU-103	1.53E+03	NO DATA	6.58E+02	NO DATA	5.83E+03	5.05E+05	1.10E+05
RU-106	6.91E+04	NO DATA	8.72E+03	NO DATA	1.34E+05	9.36E+06	9.12E+05
AG-110m	1.08E+04	1.00E+04	5.94E+03	NO DATA	1.97E+04	4.63E+06	3.02E+05
TE-125m	3.42E+03	1.58E+03	4.67E+02	1.05E+03	1.24E+04	3.14E+05	7.06E+04
TE-127m	1.26E+04	5.77E+03	1.57E+03	3.29E+03	4.58E+04	9.60E+05	1.50E+05
TE-129m	9.76E+03	4.67E+03	1.58E+03	3.44E+03	3.66E+04	1.16E+06	3.83E+05
I-130	4.58E+03	1.34E+04	5.28E+03	1.14E+06	2.09E+04	NO DATA	7.69E+03
I-131	2.52E+04	3.58E+04	2.05E+04	1.19E+07	6.13E+04	NO DATA	6.28E+03
I-132	1.16E+03	3.26E+03	1.16E+03	1.14E+05	5.18E+03	NO DATA	4.06E+02
I-133	8.64E+03	1.48E+04	4.52E+03	2.15E+06	2.58E+04	NO DATA	8.88E+03
I-134	6.44E+02	1.73E+03	6.15E+02	2.98E+04	2.75E+03	NO DATA	1.01E+00
I-135	2.68E+03	6.98E+03	2.57E+03	4.48E+05	1.11E+04	NO DATA	5.25E+03
CS-134	3.73E+05	8.48E+05	7.28E+05	NO DATA	2.87E+05	9.76E+04	1.04E+04
CS-136	3.90E+04	1.46E+05	1.10E+05	NO DATA	8.56E+04	1.20E+04	1.17E+04
CS-137	4.78E+05	6.21E+05	4.28E+05	NO DATA	2.22E+05	7.52E+04	8.40E+03
BA-140	3.90E+04	4.90E+01	2.57E+03	NO DATA	1.67E+01	1.27E+06	2.18E+05
CE-141	1.99E+04	1.35E+04	1.53E+03	NO DATA	6.26E+03	3.62E+05	1.20E+05
CE-144	3.43E+06	1.43E+06	1.84E+05	NO DATA	8.48E+05	7.78E+06	8.16E+05
PR-143	9.36E+03	3.75E+03	4.64E+02	NO DATA	2.16E+03	2.81E+05	2.00E+05
ND-147	5.27E+03	6.10E+03	3.65E+02	NO DATA	3.56E+03	2.21E+05	1.73E+05

TABLE 3.5-17

COW MILK PATHWAY FACTORS -  $R_{ija}^c$  (INFANT)  
 ( $m^2rem/yr$  per  $\mu Ci/sec$ )

ORGAN: ISOTOPE	BONE	LIVER	T.BODY	THYROID	KIDNEY	LUNG	GI-LLI
H-3	NO DATA	2.38E+03*	2.38E+03*	2.38E+03*	2.38E+03*	2.38E+03*	2.38E+03*
P-32	1.60E+11	9.41E+09	6.20E+09	NO DATA	NO DATA	NO DATA	2.16E+09
CR-51	NO DATA	NO DATA	1.61E+05	1.05E+05	2.29E+04	2.04E+05	4.69E+06
MN-54	NO DATA	3.90E+07	8.84E+06	NO DATA	8.64E+06	NO DATA	1.43E+07
FE-55	1.35E+08	8.72E+07	2.33E+07	NO DATA	NO DATA	4.26E+07	1.11E+07
FE-59	2.25E+08	3.92E+08	1.55E+08	NO DATA	NO DATA	1.16E+08	1.87E+08
CO-58	NO DATA	2.43E+07	6.06E+07	NO DATA	NO DATA	NO DATA	6.05E+07
CO-60	NO DATA	8.82E+07	2.08E+08	NO DATA	NO DATA	NO DATA	2.10E+08
NI-63	3.50E+10	2.16E+09	1.21E+09	NO DATA	NO DATA	NO DATA	1.08E+08
ZN-65	5.55E+09	1.91E+10	8.78E+09	NO DATA	9.23E+09	NO DATA	1.61E+10
RB-86	NO DATA	2.23E+10	1.10E+10	NO DATA	NO DATA	NO DATA	5.70E+08
SR-89	1.26E+10	NO DATA	3.61E+08	NO DATA	NO DATA	NO DATA	2.59E+08
SR-90	1.22E+11	NO DATA	3.10E+10	NO DATA	NO DATA	NO DATA	1.52E+09
Y-90	6.83E+02	NO DATA	1.83E+01	NO DATA	NO DATA	NO DATA	9.43E+05
Y-91	7.33E+04	NO DATA	1.95E+03	NO DATA	NO DATA	NO DATA	5.26E+06
ZR-95	6.82E+03	1.66E+03	1.18E+03	NO DATA	1.79E+03	NO DATA	8.28E+05
NB-95	5.93E+05	2.44E+05	1.41E+05	NO DATA	1.75E+05	NO DATA	2.06E+08
MO-99	NO DATA	2.07E+08	4.04E+07	NO DATA	3.10E+08	NO DATA	6.83E+07
TC-99m	2.75E+01	5.66E+01	7.29E+02	NO DATA	6.09E+02	2.96E+01	1.64E+04
RU-103	8.67E+03	NO DATA	2.92E+03	NO DATA	1.81E+04	NO DATA	1.06E+05
RU-106	1.91E+05	NO DATA	2.38E+04	NO DATA	2.26E+05	NO DATA	1.45E+06
AG-110m	3.85E+08	2.81E+08	1.86E+08	NO DATA	4.02E+08	NO DATA	1.46E+10
TE-125m	1.51E+08	5.05E+07	2.04E+07	5.08E+07	NO DATA	NO DATA	7.19E+07
TE-127m	4.22E+08	1.40E+08	5.10E+07	1.22E+08	1.04E+09	NO DATA	1.70E+08
TE-129m	5.56E+08	1.91E+08	8.56E+07	2.14E+08	1.39E+09	NO DATA	3.32E+08
I-130	3.53E+06	7.76E+06	3.12E+06	8.70E+08	8.53E+06	NO DATA	1.66E+06
I-131	2.71E+09	3.19E+09	1.40E+09	1.05E+12	3.73E+09	NO DATA	1.14E+08
I-132	1.43E+00	2.90E+00	1.03E+00	1.36E+02	3.24E+00	NO DATA	2.35E+00
I-133	3.63E+07	5.28E+07	1.55E+07	9.60E+09	6.21E+07	NO DATA	8.93E+06
I-134	1.64E-11	3.36E-11	1.20E-11	7.86E-10	3.76E-11	NO DATA	3.48E-11
I-135	1.13E+05	2.24E+05	8.18E+04	2.01E+07	2.50E+05	NO DATA	8.12E+04
CS-134	3.65E+10	6.81E+10	6.88E+09	NO DATA	1.75E+10	7.19E+09	1.85E+08
CS-136	1.97E+09	5.81E+09	2.17E+09	NO DATA	2.31E+09	4.73E+08	8.82E+07
CS-137	5.15E+10	6.03E+10	4.27E+09	NO DATA	1.62E+10	6.44E+09	1.89E+08
BA-140	2.45E+08	2.45E+05	1.26E+07	NO DATA	5.72E+04	1.50E+05	5.92E+07
CE-141	4.34E+04	2.65E+04	3.12E+03	NO DATA	8.17E+03	NO DATA	1.37E+07
CE-144	2.34E+06	9.56E+05	1.31E+05	NO DATA	3.87E+05	NO DATA	1.34E+08
PR-143	1.49E+03	5.56E+02	7.37E+01	NO DATA	2.07E+02	NO DATA	7.85E+05
ND-147	8.79E+02	9.03E+02	5.53E+01	NO DATA	3.48E+02	NO DATA	5.72E+05

\*mrem/yr per  $\mu Ci/m^3$



TABLE 3.5-18

COW MILK PATHWAY FACTORS -  $R_{ija}^c$  (CHILD)  
( $m^2$ mrem/yr per  $\mu$ Ci/sec)

ORGAN: ISOTOPE	BONE	LIVER	T.BODY	THYROID	KIDNEY	LUNG	GI-LLI
H-3	NO DATA	1.57E+03*	1.57E+03*	1.57E+03*	1.57E+03*	1.57E+03*	1.57E+03*
P-32	7.79E+10	3.64E+09	3.00E+09	NO DATA	NO DATA	NO DATA	2.15E+09
CR-51	NO DATA	NO DATA	1.01E+05	5.63E+04	1.54E+04	1.03E+05	5.38E+06
MN-54	NO DATA	2.10E+07	5.59E+06	NO DATA	5.88E+06	NO DATA	1.76E+07
FE-55	1.12E+08	5.94E+07	1.84E+07	NO DATA	NO DATA	3.36E+07	1.10E+07
FE-59	1.20E+08	1.95E+08	9.71E+07	NO DATA	NO DATA	5.65E+07	2.03E+08
CO-58	NO DATA	1.21E+07	3.71E+07	NO DATA	NO DATA	NO DATA	7.08E+07
CO-60	NO DATA	4.32E+07	1.27E+08	NO DATA	NO DATA	NO DATA	2.39E+08
NI-63	2.97E+10	1.59E+09	1.01E+09	NO DATA	NO DATA	NO DATA	1.07E+08
ZN-65	4.13E+09	1.10E+10	6.83E+09	NO DATA	6.92E+09	NO DATA	1.93E+09
RB-86	NO DATA	8.78E+09	5.40E+09	NO DATA	NO DATA	NO DATA	5.65E+08
SR-89	6.63E+09	NO DATA	1.89E+08	NO DATA	NO DATA	NO DATA	2.57E+08
SR-90	1.12E+11	NO DATA	2.84E+10	NO DATA	NO DATA	NO DATA	1.51E+09
Y-90	3.23E+02	NO DATA	8.65E+00	NO DATA	NO DATA	NO DATA	9.20E+05
Y-91	3.90E+04	NO DATA	1.04E+03	NO DATA	NO DATA	NO DATA	5.20E+06
ZR-95	3.84E+03	8.44E+02	7.51E+02	NO DATA	1.21E+03	NO DATA	8.80E+05
NB-95	3.18E+05	1.24E+05	8.84E+04	NO DATA	1.16E+05	NO DATA	2.29E+08
MO-99	NO DATA	8.15E+07	2.02E+07	NO DATA	1.74E+08	NO DATA	6.74E+07
TC-99m	1.32E+01	2.58E+01	4.28E+02	NO DATA	3.75E+02	1.31E+01	1.47E+04
RU-103	4.29E+03	NO DATA	1.65E+03	NO DATA	1.08E+04	NO DATA	1.11E+05
RU-106	9.25E+04	NO DATA	1.15E+04	NO DATA	1.25E+05	NO DATA	1.44E+06
AG-110m	2.09E+08	1.41E+08	1.13E+08	NO DATA	2.63E+08	NO DATA	1.68E+10
TE-125m	7.39E+07	2.00E+07	9.85E+07	2.07E+07	NO DATA	NO DATA	7.13E+07
TE-127m	2.08E+08	5.61E+07	2.47E+07	4.98E+07	5.94E+08	NO DATA	1.69E+08
TE-129m	2.71E+08	7.58E+07	4.21E+07	8.74E+07	7.97E+08	NO DATA	3.31E+08
I-130	1.72E+06	3.47E+06	1.79E+06	3.82E+08	5.19E+06	NO DATA	1.62E+06
I-131	1.30E+09	1.31E+09	7.44E+08	4.33E+11	2.15E+09	NO DATA	1.17E+08
I-132	6.91E-01	1.27E+00	5.84E-01	5.89E+01	1.94E+00	NO DATA	1.49E+00
I-133	1.72E+07	2.12E+07	8.03E+06	3.94E+09	3.54E+07	NO DATA	8.56E+06
I-134	7.92E-12	1.47E-11	6.77E-12	3.38E-10	2.25E-11	NO DATA	9.75E-12
I-135	5.43E+04	9.77E+04	4.62E+04	8.56E+06	1.50E+05	NO DATA	7.44E+04
CS-134	2.27E+10	3.72E+10	7.85E+09	NO DATA	1.15E+10	4.14E+09	2.01E+08
CS-136	1.01E+09	2.78E+09	1.80E+09	NO DATA	1.48E+09	2.21E+08	9.76E+07
CS-137	3.23E+10	3.09E+10	4.56E+09	NO DATA	1.01E+10	3.63E+09	1.94E+08
BA-140	1.18E+08	1.03E+05	6.84E+06	NO DATA	3.37E+04	6.12E+04	5.94E+07
CE-141	2.19E+04	1.09E+04	1.62E+03	NO DATA	4.78E+03	NO DATA	1.36E+07
CE-144	1.63E+06	5.10E+05	8.68E+04	NO DATA	2.82E+05	NO DATA	1.33E+08
PR-143	7.19E+02	2.16E+02	3.57E+01	NO DATA	1.17E+02	NO DATA	7.76E+05
ND-147	4.44E+02	3.59E+02	2.78E+01	NO DATA	1.97E+02	NO DATA	5.69E+05

\*mrem/yr per  $\mu$ Ci/ $m^3$

TABLE 3.5-19

COW MILK PATHWAY FACTORS -  $R_{ija}^c$  (TEEN)  
( $m^2$ mrem/yr per  $\mu$ Ci)

ORGAN: ISOTOPE	BONE	LIVER	T.BODY	THYROID	KIDNEY	LUNG	GI-LLI
H-3	NO DATA	9.92E+02*	9.92E+02*	9.92E+02*	9.92E+02*	9.92E+02*	9.92E+02*
P-32	3.15E+10	1.95E+09	1.22E+09	NO DATA	NO DATA	NO DATA	2.64E+09
CR-51	NO DATA	NO DATA	5.00E+04	2.78E+04	1.10E+04	7.14E+04	8.41E+06
MN-54	NO DATA	1.40E+07	2.78E+06	NO DATA	4.19E+06	NO DATA	2.88E+07
FE-55	4.46E+07	3.16E+07	7.38E+06	NO DATA	NO DATA	2.01E+07	1.37E+07
FE-59	5.18E+07	1.21E+08	4.67E+07	NO DATA	NO DATA	3.81E+07	2.68E+08
CO-58	NO DATA	7.98E+06	1.84E+07	NO DATA	NO DATA	NO DATA	1.10E+08
CO-60	NO DATA	2.78E+07	6.26E+07	NO DATA	NO DATA	NO DATA	3.62E+08
NI-63	1.18E+10	8.34E+08	4.00E+08	NO DATA	NO DATA	NO DATA	1.33E+08
ZN-65	2.11E+09	7.32E+09	3.41E+09	NO DATA	4.68E+09	NO DATA	3.10E+09
RB-86	NO DATA	4.74E+09	2.23E+09	NO DATA	NO DATA	NO DATA	7.01E+08
SR-89	2.68E+09	NO DATA	7.67E+07	NO DATA	NO DATA	NO DATA	3.19E+08
SR-90	6.62E+10	NO DATA	1.64E+10	NO DATA	NO DATA	NO DATA	1.86E+09
Y-90	1.31E+02	NO DATA	3.53E+00	NO DATA	NO DATA	NO DATA	1.08E+06
Y-91	1.58E+04	NO DATA	4.24E+02	NO DATA	NO DATA	NO DATA	6.48E+06
ZR-95	1.65E+03	5.20E+02	3.58E+02	NO DATA	7.65E+02	NO DATA	1.20E+06
NB-95	1.41E+05	7.81E+04	4.30E+04	NO DATA	7.57E+04	NO DATA	3.34E+08
MO-99	NO DATA	4.46E+07	8.50E+06	NO DATA	1.02E+08	NO DATA	7.98E+07
TC-99m	5.74E+00	1.60E+01	2.08E+02	NO DATA	2.39E+02	8.89E+00	1.05E+04
RU-103	1.81E+03	NO DATA	7.73E+02	NO DATA	6.37E+03	NO DATA	1.51E+05
RU-106	3.75E+04	NO DATA	4.73E+03	NO DATA	7.23E+04	NO DATA	1.80E+06
AG-110m	9.64E+07	9.12E+07	5.55E+07	NO DATA	1.74E+08	NO DATA	2.56E+10
TE-125m	3.01E+07	1.08E+07	4.02E+06	8.41E+06	NO DATA	NO DATA	8.88E+07
TE-127m	8.43E+07	2.99E+07	1.00E+07	2.01E+07	3.42E+08	NO DATA	2.10E+08
TE-129m	1.10E+08	4.09E+07	1.74E+07	3.56E+07	4.61E+08	NO DATA	4.14E+08
I-130	7.33E+05	2.12E+06	8.47E+05	1.73E+08	3.27E+06	NO DATA	1.63E+06
I-131	5.36E+08	7.50E+08	4.03E+08	2.19E+11	1.29E+09	NO DATA	1.48E+08
I-132	2.90E-01	7.59E-01	2.72E-01	2.56E+01	1.20E+00	NO DATA	3.31E-01
I-133	7.06E+06	1.20E+07	3.65E+06	1.67E+09	2.10E+07	NO DATA	9.06E+06
I-134	3.34E-12	8.86E-12	3.18E-12	1.48E-10	1.40E-11	NO DATA	1.17E-13
I-135	2.29E+04	5.90E+04	2.19E+04	3.80E+06	9.32E+04	NO DATA	6.54E+04
CS-134	9.79E+09	2.30E+10	1.07E+10	NO DATA	7.32E+09	2.80E+09	2.87E+08
CS-136	4.48E+08	1.76E+09	1.18E+09	NO DATA	9.59E+08	1.51E+08	1.42E+08
CS-137	1.33E+10	1.77E+10	6.18E+09	NO DATA	6.03E+09	2.34E+09	2.52E+08
BA-140	4.85E+07	5.95E+04	3.13E+06	NO DATA	2.02E+04	4.00E+04	7.49E+07
CE-141	8.88E+03	5.93E+03	6.81E+02	NO DATA	2.79E+03	NO DATA	1.70E+07
CE-144	6.61E+05	2.73E+05	3.55E+04	NO DATA	1.63E+05	NO DATA	1.66E+08
PR-143	2.91E+02	1.16E+02	1.45E+01	NO DATA	6.75E+01	NO DATA	9.57E+05
ND-147	1.81E+02	1.97E+02	1.18E+01	NO DATA	1.16E+02	NO DATA	7.10E+05

\*mrem/yr per  $\mu$ Ci/ $m^3$

TABLE 3.5-20

COW MILK PATHWAY FACTORS -  $R_{ija}^C$  (ADULT)  
( $m^2mrem/yr$  per  $\mu Ci/sec$ )

ORGAN: ISOTOPE	BONE	LIVER	T.BODY	THYROID	KIDNEY	LUNG	GI-LLI
H-3	NO DATA	7.62E+02*	7.62E+02*	7.62E+02*	7.62E+02*	7.62E+02*	7.62E+02*
P-32	1.71E+10	1.06E+09	6.61E+08	NO DATA	NO DATA	NO DATA	1.92E+09
CR-51	NO DATA	NO DATA	2.85E+04	1.70E+04	6.27E+03	3.78E+04	7.16E+06
MN-54	NO DATA	8.41E+06	1.60E+06	NO DATA	2.50E+06	NO DATA	2.58E+07
FE-55	2.51E+07	1.73E+07	4.04E+06	NO DATA	NO DATA	9.68E+06	9.95E+06
FE-59	2.97E+07	6.99E+07	2.68E+07	NO DATA	NO DATA	1.95E+07	2.33E+08
CO-58	NO DATA	4.72E+06	1.06E+07	NO DATA	NO DATA	NO DATA	9.57E+07
CO-60	NO DATA	1.64E+07	3.62E+07	NO DATA	NO DATA	NO DATA	3.08E+08
NI-63	6.73E+09	4.67E+08	2.26E+08	NO DATA	NO DATA	NO DATA	9.74E+07
ZN-65	1.37E+09	4.37E+09	1.98E+09	NO DATA	2.93E+09	NO DATA	2.75E+09
RB-86	NO DATA	2.60E+09	1.21E+09	NO DATA	NO DATA	NO DATA	5.12E+08
SR-89	1.45E+09	NO DATA	4.16E+07	NO DATA	NO DATA	NO DATA	2.33E+08
SR-90	4.68E+10	NO DATA	1.15E+10	NO DATA	NO DATA	NO DATA	1.35E+09
Y-90	7.10E+01	NO DATA	1.90E+00	NO DATA	NO DATA	NO DATA	7.53E+05
Y-91	8.60E+03	NO DATA	2.30E+02	NO DATA	NO DATA	NO DATA	4.73E+06
ZR-95	9.45E+02	3.03E+02	2.05E+02	NO DATA	4.76E+02	NO DATA	9.61E+05
NB-95	8.25E+04	4.59E+04	2.47E+04	NO DATA	4.54E+04	NO DATA	2.79E+08
MO-99	NO DATA	2.48E+07	4.72E+06	NO DATA	5.61E+07	NO DATA	5.74E+07
TC-99m	3.31E+00	9.35E+00	1.19E+02	NO DATA	1.42E+02	4.58E+00	5.53E+03
RU-103	1.02E+03	NO DATA	4.39E+02	NO DATA	3.89E+03	NO DATA	1.19E+05
RU-106	2.04E+04	NO DATA	2.58E+03	NO DATA	3.94E+04	NO DATA	1.32E+06
AG-110m	5.82E+07	5.39E+07	3.20E+07	NO DATA	1.06E+08	NO DATA	2.20E+10
TE-125m	1.63E+07	5.91E+06	2.19E+06	4.91E+06	6.64E+07	NO DATA	6.52E+07
TE-127m	4.58E+07	1.64E+07	5.58E+06	1.17E+07	1.86E+08	NO DATA	1.53E+08
TE-129m	6.01E+07	2.24E+07	9.52E+06	2.07E+07	2.51E+08	NO DATA	3.03E+08
I-130	4.16E+05	1.23E+06	4.84E+05	1.04E+08	1.91E+06	NO DATA	1.06E+06
I-131	2.97E+08	4.24E+08	2.43E+08	1.39E+11	7.27E+08	NO DATA	1.12E+08
I-132	1.65E-01	4.40E-01	1.54E-01	1.54E+01	7.02E-01	NO DATA	8.27E-02
I-133	3.86E+06	6.72E+06	2.05E+06	9.87E+08	1.17E+07	NO DATA	6.04E+06
I-134	1.89E-12	5.13E-12	1.83E-12	8.88E-11	8.15E-12	NO DATA	4.47E-15
I-135	1.29E+04	3.39E+04	1.25E+04	2.23E+06	5.43E+04	NO DATA	3.83E+04
CS-134	5.67E+09	1.35E+10	1.10E+10	NO DATA	4.37E+09	1.45E+09	2.36E+08
CS-136	2.64E+08	1.04E+09	7.49E+08	NO DATA	5.79E+08	7.94E+07	1.18E+08
CS-137	7.39E+09	1.01E+10	6.62E+09	NO DATA	3.43E+09	1.14E+09	1.96E+08
BA-140	2.72E+07	3.42E+04	1.78E-06	NO DATA	1.16E+04	1.96E+04	5.60E+07
CE-141	4.84E+03	3.27E+03	3.71E+02	NO DATA	1.52E+03	NO DATA	1.25E+07
CE-144	3.58E+05	1.50E+05	1.92E+04	NO DATA	8.87E+04	NO DATA	1.21E+08
PR-143	1.58E+02	6.35E+01	7.84E+00	NO DATA	3.66E+01	NO DATA	6.93E+05
ND-147	9.44E+01	1.09E+02	6.53E+00	NO DATA	6.38E+01	NO DATA	5.24E+05

\* $mrem/yr$  per  $\mu Ci/m^3$

TABLE 3.5-21

GOAT MILK PATHWAY FACTORS -  $R_{ija}^c$  (INFANT)  
 ( $m^2$ mrem/yr per  $\mu$ Ci/sec)

ORGAN: ISOTOPE	BONE	LIVER	T.BODY	THYROID	KIDNEY	LUNG	GI-LLI
H-3	NO DATA	4.86E+03*	4.86E+03*	4.86E+03*	4.86E+03*	4.86E+03*	4.86E+03*
P-32	1.90E+11	1.12E+10	7.46E+09	NO DATA	NO DATA	NO DATA	2.58E+09
CR-51	NO DATA	NO DATA	1.93E+04	1.26E+04	2.75E+03	2.45E+04	5.63E+05
MN-54	NO DATA	4.68E+06	1.06E+06	NO DATA	1.04E+06	NO DATA	1.72E+06
FE-55	1.75E+06	1.13E+06	3.02E+05	NO DATA	NO DATA	5.53E+05	1.44E+05
FE-59	2.91E+06	5.08E+06	2.00E+06	NO DATA	NO DATA	1.50E+06	2.43E+06
CO-58	NO DATA	2.90E+06	7.24E+06	NO DATA	NO DATA	NO DATA	7.23E+06
CO-60	NO DATA	1.06E+07	2.49E+07	NO DATA	NO DATA	NO DATA	2.51E+07
NI-63	4.19E+09	2.59E+08	1.45E+08	NO DATA	NO DATA	NO DATA	1.29E+07
ZN-65	6.64E+08	2.28E+09	1.05E+09	NO DATA	1.10E+09	NO DATA	1.92E+09
RB-86	NO DATA	2.65E+09	1.31E+09	NO DATA	NO DATA	NO DATA	6.79E+07
SR-89	2.64E+10	NO DATA	7.56E+08	NO DATA	NO DATA	NO DATA	5.42E+08
SR-90	2.55E+11	NO DATA	6.50E+10	NO DATA	NO DATA	NO DATA	3.19E+09
Y-90	8.19E+01	NO DATA	2.19E+00	NO DATA	NO DATA	NO DATA	1.13E+05
Y-91	8.78E+03	NO DATA	2.34E+02	NO DATA	NO DATA	NO DATA	6.29E+05
ZR-95	8.16E+02	1.99E+02	1.41E+02	NO DATA	2.14E+02	NO DATA	9.90E+04
NB-95	7.12E+04	2.93E+04	1.69E+04	NO DATA	2.10E+04	NO DATA	2.47E+07
MO-99	NO DATA	2.48E+07	4.84E+06	NO DATA	3.71E+07	NO DATA	8.18E+06
TC-99m	3.26E+00	6.73E+00	8.67E+01	NO DATA	7.24E+01	3.52E+00	1.96E+03
RU-103	1.04E+03	NO DATA	3.47E+02	NO DATA	2.16E+03	NO DATA	1.26E+04
RU-106	2.28E+04	NO DATA	2.84E+03	NO DATA	2.69E+04	NO DATA	1.73E+05
AG-110m	4.62E+07	3.37E+07	2.23E+07	NO DATA	4.83E+07	NO DATA	1.75E+09
TE-125m	1.80E+07	6.02E+06	2.43E+06	6.06E+06	NO DATA	NO DATA	8.58E+06
TE-127m	5.04E+07	1.67E+07	6.10E+06	1.46E+07	1.24E+08	NO DATA	2.03E+07
TE-129m	6.68E+07	2.29E+07	1.03E+07	2.57E+07	1.67E+08	NO DATA	3.99E+07
I-130	4.22E+06	9.28E+06	3.73E+06	1.04E+09	1.02E+07	NO DATA	1.99E+06
I-131	3.25E+09	3.83E+09	1.69E+09	1.26E+12	4.48E+09	NO DATA	1.37E+08
I-132	1.73E+00	3.50E+00	1.25E+00	1.64E+02	3.91E+00	NO DATA	2.84E+00
I-133	4.34E+07	6.32E+07	1.85E+07	1.15E+10	7.43E+07	NO DATA	1.07E+07
I-134	1.97E-11	4.04E-11	1.44E-11	9.42E-10	4.52E-11	NO DATA	4.18E-11
I-135	1.36E+05	2.70E+05	9.85E+04	2.42E+07	3.01E+05	NO DATA	9.77E+04
CS-134	1.09E+11	2.04E+11	2.06E+10	NO DATA	5.25E+10	2.15E+10	5.54E+08
CS-136	5.92E+09	1.74E+10	6.50E+09	NO DATA	6.94E+09	1.42E+09	2.64E+08
CS-137	1.54E+11	1.80E+11	1.28E+10	NO DATA	4.84E+10	1.96E+10	5.63E+08
BA-140	2.87E+07	2.87E+04	1.48E+06	NO DATA	6.82E+03	1.76E+04	7.06E+06
CE-141	5.20E+03	3.17E+03	3.73E+02	NO DATA	9.78E+02	NO DATA	1.64E+06
CE-144	2.79E+05	1.14E+05	1.56E+04	NO DATA	4.61E+04	NO DATA	1.60E+07
PR-143	1.78E+02	6.66E+01	8.83E+00	NO DATA	2.47E+01	NO DATA	9.40E+04
ND-147	1.06E+02	1.08E+02	6.65E+00	NO DATA	4.18E+01	NO DATA	6.88E+04

\*mrem/yr per  $\mu$ Ci/ $m^3$

TABLE 3.5-22

GOAT MILK PATHWAY FACTORS -  $R_{ija}^c$  (CHILD)  
 ( $m^2$ mrem/yr per  $\mu$ Ci/sec)

ORGAN: ISOTOPE	BONE	LIVER	T.BODY	THYROID	KIDNEY	LUNG	GI-LLI
H-3	NO DATA	3.20E+03*	3.20E+03*	3.20E+03*	3.20E+03*	3.20E+03*	3.20E+03*
P-32	9.32E+10	4.36E+09	3.59E+09	NO DATA	NO DATA	NO DATA	2.58E+09
CR-51	NO DATA	NO DATA	1.22E+04	6.77E+03	1.85E+03	1.24E+04	6.47E+05
MN-54	NO DATA	2.51E+06	6.70E+05	NO DATA	7.05E+05	NO DATA	2.11E+06
FE-55	1.45E+06	7.65E+05	2.38E+05	NO DATA	NO DATA	4.35E+05	1.42E+05
FE-59	1.55E+06	2.52E+06	1.25E+06	NO DATA	NO DATA	7.29E+05	2.62E+06
CO-58	NO DATA	1.46E+06	4.46E+06	NO DATA	NO DATA	NO DATA	8.49E+06
CO-60	NO DATA	5.16E+06	1.52E+07	NO DATA	NO DATA	NO DATA	2.86E+07
NI-63	3.55E+09	1.90E+08	1.21E+08	NO DATA	NO DATA	NO DATA	1.28E+07
ZN-65	4.96E+08	1.32E+09	8.22E+08	NO DATA	8.33E+08	NO DATA	2.32E+08
RB-86	NO DATA	1.05E+09	6.47E+08	NO DATA	NO DATA	NO DATA	6.77E+07
SR-89	1.39E+10	NO DATA	3.96E+08	NO DATA	NO DATA	NO DATA	5.37E+08
SR-90	2.35E+11	NO DATA	5.95E+10	NO DATA	NO DATA	NO DATA	3.16E+09
Y-90	3.86E+01	NO DATA	1.03E+00	NO DATA	NO DATA	NO DATA	1.10E+05
Y-91	4.67E+03	NO DATA	1.25E+02	NO DATA	NO DATA	NO DATA	6.22E+05
ZR-95	4.58E+02	1.01E+02	8.97E+01	NO DATA	1.44E+02	NO DATA	1.05E+05
NB-95	3.81E+04	1.48E+04	1.06E+04	NO DATA	1.39E+04	NO DATA	2.75E+07
MO-99	NO DATA	9.74E+06	2.41E+06	NO DATA	2.08E+07	NO DATA	8.05E+06
TC-99m	1.58E+00	3.10E+00	5.13E+01	NO DATA	4.50E+01	1.57E+00	1.76E+03
RU-103	5.10E+02	NO DATA	1.96E+02	NO DATA	1.28E+03	NO DATA	1.32E+04
RU-106	1.11E+04	NO DATA	1.38E+03	NO DATA	1.49E+04	NO DATA	1.72E+05
AG-110m	2.50E+07	1.69E+07	1.35E+07	NO DATA	3.15E+07	NO DATA	2.01E+09
TE-125m	8.84E+06	2.39E+06	1.18E+06	2.48E+06	NO DATA	NO DATA	8.53E+06
TE-127m	2.49E+07	6.71E+06	2.96E+06	5.96E+06	7.10E+07	NO DATA	2.02E+07
TE-129m	3.24E+07	9.06E+06	5.03E+06	1.05E+07	9.52E+07	NO DATA	3.96E+07
I-130	2.06E+06	4.17E+06	2.15E+06	4.59E+08	6.23E+06	NO DATA	1.95E+06
I-131	1.56E+09	1.57E+09	8.94E+08	5.20E+11	2.58E+09	NO DATA	1.40E+08
I-132	8.32E-01	1.52E+00	7.03E-01	7.09E+01	2.34E+00	NO DATA	1.80E+00
I-133	2.06E+07	2.55E+07	9.64E+06	4.73E+09	4.25E+07	NO DATA	1.03E+07
I-134	9.51E-12	1.77E-11	8.13E-12	4.06E-10	2.70E-11	NO DATA	1.17E-11
I-135	6.53E+04	1.17E+05	5.56E+04	1.04E+07	1.80E+05	NO DATA	8.95E+04
CS-134	6.76E+10	1.11E+11	2.34E+10	NO DATA	3.44E+10	1.23E+10	5.98E+08
CS-136	3.03E+09	8.33E+09	5.39E+09	NO DATA	4.44E+09	6.62E+08	2.93E+08
CS-137	9.65E+10	9.23E+10	1.36E+10	NO DATA	3.01E+10	1.08E+10	5.78E+08
BA-140	1.40E+07	1.22E+04	8.15E+05	NO DATA	3.98E+03	7.29E+03	7.07E+06
CE-141	2.62E+03	1.31E+03	1.94E+02	NO DATA	5.73E+02	NO DATA	1.63E+06
CE-144	1.94E+05	6.10E+04	1.04E+04	NO DATA	3.38E+04	NO DATA	1.59E+07
PR-143	8.61E+01	2.58E+01	4.27E+00	NO DATA	1.40E+01	NO DATA	9.29E+04
ND-147	5.33E+01	4.32E+01	3.34E+00	NO DATA	2.37E+01	NO DATA	6.84E+04

\*mrem/yr per  $\mu$ Ci/ $m^3$

TABLE 3.5-23

GOAT MILK PATHWAY FACTORS -  $R_{ija}^c$  (TEEN)  
( $m^2mrem/yr$  per  $\mu Ci$ )

ORGAN: ISOTOPE	BONE	LIVER	T.BODY	THYROID	KIDNEY	LUNG	GI-LLI
H-3	NO DATA	2.02E+03*	2.02E+03*	2.02E+03*	2.02E+03*	2.02E+03*	2.02E+03*
P-32	3.78E+10	2.34E+09	1.47E+09	NO DATA	NO DATA	NO DATA	3.18E+09
CR-51	NO DATA	NO DATA	5.94E+03	3.30E+03	1.30E+03	8.48E+03	9.98E+05
MN-54	NO DATA	1.68E+06	3.32E+05	NO DATA	5.00E+05	NO DATA	3.44E+06
FE-55	5.79E+05	4.11E+05	9.57E+04	NO DATA	NO DATA	2.60E+05	1.78E+05
FE-59	6.75E+05	1.58E+06	6.08E+05	NO DATA	NO DATA	4.97E+05	3.73E+06
CO-58	NO DATA	9.51E+05	2.19E+06	NO DATA	NO DATA	NO DATA	1.31E+07
CO-60	NO DATA	3.32E+06	7.47E+06	NO DATA	NO DATA	NO DATA	4.32E+07
NI-63	1.42E+09	1.00E+08	4.81E+07	NO DATA	NO DATA	NO DATA	1.60E+07
ZN-65	2.52E+08	8.76E+08	4.09E+08	NO DATA	5.61E+08	NO DATA	3.71E+08
RB-86	NO DATA	5.66E+08	2.66E+08	NO DATA	NO DATA	NO DATA	8.38E+07
SR-89	5.59E+09	NO DATA	1.60E+08	NO DATA	NO DATA	NO DATA	6.65E+08
SR-90	1.38E+11	NO DATA	3.40E+10	NO DATA	NO DATA	NO DATA	3.87E+09
Y-90	1.56E+01	NO DATA	4.21E-01	NO DATA	NO DATA	NO DATA	1.29E+05
Y-91	1.89E+03	NO DATA	5.07E+01	NO DATA	NO DATA	NO DATA	7.75E+05
ZR-95	1.98E+02	6.24E+01	4.29E+01	NO DATA	9.17E+01	NO DATA	1.44E+05
NB-95	1.69E+04	9.37E+03	5.16E+03	NO DATA	9.08E+03	NO DATA	4.01E+07
MO-99	NO DATA	5.33E+06	1.02E+06	NO DATA	1.22E+07	NO DATA	9.55E+06
TC-99m	6.87E-01	1.92E+00	2.48E+01	NO DATA	2.86E+01	1.06E+00	1.26E+03
RU-103	2.17E+02	NO DATA	9.27E+01	NO DATA	7.64E+02	NO DATA	1.81E+04
RU-106	4.47E+03	NO DATA	5.63E+02	NO DATA	8.62E+03	NO DATA	2.14E+05
AG-110m	1.15E+07	1.09E+07	6.62E+06	NO DATA	2.08E+07	NO DATA	3.06E+09
TE-125m	3.59E+06	1.29E+06	4.80E+05	1.00E+06	NO DATA	NO DATA	1.06E+07
TE-127m	1.01E+07	3.57E+06	1.20E+06	2.39E+06	4.08E+07	NO DATA	2.51E+07
TE-129m	1.32E+07	4.89E+06	2.08E+06	4.25E+06	5.51E+07	NO DATA	4.94E+07
I-130	8.82E+05	2.55E+06	1.02E+06	2.08E+08	3.93E+06	NO DATA	1.96E+06
I-131	6.44E+08	9.01E+08	4.84E+08	2.63E+11	1.55E+09	NO DATA	1.78E+08
I-132	3.52E-01	9.20E-01	3.30E-01	3.10E+01	1.45E+00	NO DATA	4.01E-01
I-133	8.48E+06	1.44E+07	4.39E+06	2.01E+09	2.52E+07	NO DATA	1.09E+07
I-134	4.03E-12	1.07E-11	3.84E-12	1.78E-10	1.68E-11	NO DATA	1.41E-13
I-135	2.75E+04	7.08E+04	2.62E+04	4.56E+06	1.12E+05	NO DATA	7.85E+04
CS-134	2.94E+10	6.91E+10	3.21E+10	NO DATA	2.20E+10	8.39E+09	8.60E+08
CS-136	1.34E+09	5.27E+09	3.54E+09	NO DATA	2.87E+09	4.52E+08	4.24E+08
CS-137	4.01E+10	5.33E+10	1.86E+10	NO DATA	1.82E+10	7.05E+09	7.59E+08
BA-140	5.82E+06	7.13E+03	3.75E+05	NO DATA	2.42E+03	4.80E+03	8.98E+06
CE-141	1.07E+03	7.12E+02	8.17E+01	NO DATA	3.35E+02	NO DATA	2.04E+06
CE-144	7.86E+04	3.25E+04	4.23E+03	NO DATA	1.94E+04	NO DATA	1.98E+07
PR-143	3.47E+01	1.39E+01	1.73E+00	NO DATA	8.06E+00	NO DATA	1.14E+05
ND-147	2.17E+01	2.36E+01	1.41E+00	NO DATA	1.38E+01	NO DATA	8.50E+04

\* $mrem/yr$  per  $\mu Ci/m^3$

TABLE 3.5-24

GOAT MILK PATHWAY FACTORS -  $R_{ija}^C$  (ADULT)  
 ( $m^2mrem/yr$  per  $\mu Ci/sec$ )

ORGAN: ISOTOPE	BONE	LIVER	T.BODY	THYROID	KIDNEY	LUNG	GI-LLI
H-3	NO DATA	1.55E+03*	1.55E+03*	1.55E+03*	1.55E+03*	1.55E+03*	1.55E+03*
P-32	2.05E+10	1.27E+09	7.91E+08	NO DATA	NO DATA	NO DATA	2.30E+09
CR-51	NO DATA	NO DATA	3.43E+03	2.05E+03	7.56E+02	4.55E+03	8.63E+05
MN-54	NO DATA	1.01E+06	1.92E+05	NO DATA	2.99E+05	NO DATA	3.08E+06
FE-55	3.27E+05	2.26E+05	5.27E+04	NO DATA	NO DATA	1.26E+05	1.30E+05
FE-59	3.85E+05	9.06E+05	3.47E+05	NO DATA	NO DATA	2.53E+05	3.02E+06
CO-58	NO DATA	5.62E+05	1.26E+06	NO DATA	NO DATA	NO DATA	1.14E+07
CO-60	NO DATA	1.96E+06	4.33E+06	NO DATA	NO DATA	NO DATA	3.69E+07
NI-63	8.05E+08	5.58E+07	2.70E+07	NO DATA	NO DATA	NO DATA	1.16E+07
ZN-65	1.64E+08	5.22E+08	2.36E+08	NO DATA	3.49E+08	NO DATA	3.29E+08
RB-86	NO DATA	3.10E+08	1.45E+08	NO DATA	NO DATA	NO DATA	6.12E+07
SR-89	3.04E+09	NO DATA	8.73E+07	NO DATA	NO DATA	NO DATA	4.88E+08
SR-90	9.78E+10	NO DATA	2.40E+10	NO DATA	NO DATA	NO DATA	2.83E+09
Y-90	8.48E+00	NO DATA	2.28E-01	NO DATA	NO DATA	NO DATA	9.00E+04
Y-91	1.03E+03	NO DATA	2.75E+01	NO DATA	NO DATA	NO DATA	5.66E+05
ZR-95	1.13E+02	3.63E+01	2.46E+01	NO DATA	5.69E+01	NO DATA	1.15E+05
NB-95	9.90E+03	5.51E+03	2.96E+03	NO DATA	5.45E+03	NO DATA	3.34E+07
MO-99	NO DATA	2.96E+06	5.63E+05	NO DATA	6.71E+06	NO DATA	6.86E+06
TC-99m	3.95E-01	1.12E+00	1.42E+01	NO DATA	1.70E+01	5.47E-01	6.61E+02
RU-103	1.22E+02	NO DATA	5.24E+01	NO DATA	4.64E+02	NO DATA	1.42E+04
RU-106	2.44E+03	NO DATA	3.09E+02	NO DATA	4.72E+03	NO DATA	1.58E+05
AG-110m	6.96E+06	6.44E+06	3.82E+06	NO DATA	1.27E+07	NO DATA	2.63E+09
TE-125m	1.95E+06	7.07E+05	2.61E+05	5.87E+05	7.94E+06	NO DATA	7.79E+06
TE-127m	5.46E+06	1.95E+06	6.66E+05	1.40E+06	2.22E+07	NO DATA	2.83E+07
TE-129m	7.21E+06	2.69E+06	1.14E+06	2.48E+06	3.01E+07	NO DATA	3.63E+07
I-130	5.00E+05	1.47E+06	5.82E+05	1.25E+08	2.30E+06	NO DATA	1.27E+06
I-131	3.54E+08	5.06E+08	2.90E+08	1.66E+11	8.68E+08	NO DATA	1.34E+08
I-132	1.98E-01	5.29E-01	1.85E-01	1.85E+01	8.43E-01	NO DATA	9.93E-02
I-133	4.62E+06	8.03E+06	2.45E+06	1.18E+09	1.40E+07	NO DATA	7.22E+06
I-134	2.27E+12	6.16E-12	2.20E-12	1.07E-10	9.80E-12	NO DATA	5.37E-15
I-135	1.55E+04	4.06E+04	1.50E+04	2.68E+06	6.51E+04	NO DATA	4.59E+04
CS-134	1.69E+10	4.03E+10	3.29E+10	NO DATA	1.30E+10	4.32E+09	7.04E+08
CS-136	7.88E+08	3.11E+09	2.24E+09	NO DATA	1.73E+09	2.37E+08	3.53E+08
CS-137	2.21E+10	3.03E+10	1.98E+10	NO DATA	1.02E+10	3.41E+09	5.84E+08
BA-140	3.23E+06	4.05E+03	2.11E+05	NO DATA	1.38E+03	2.32E+03	6.65E+06
CE-141	5.80E+02	3.92E+02	4.45E+01	NO DATA	1.82E+02	NO DATA	1.50E+06
CE-144	4.29E+04	1.79E+04	2.30E+03	NO DATA	1.06E+04	NO DATA	1.45E+07
PR-143	1.89E+01	7.56E+00	9.35E-01	NO DATA	4.37E+00	NO DATA	8.26E+04
ND-147	1.13E+01	1.30E+01	7.79E-01	NO DATA	7.64E+00	NO DATA	6.25E+04

\*mrem/yr per  $\mu Ci/m^3$

TABLE 3.5-25

 MEAT PATHWAY FACTORS -  $R_{ija}^M$  (CHILD)  
 ( $m^2mrem/yr$  per  $\mu Ci/sec$ )

ORGAN: ISOTOPE	BONE	LIVER	T.BODY	THYROID	KIDNEY	LUNG	GI-LLI
H-3	NO DATA	2.33E+02*	2.33E+02*	2.33E+02*	2.33E+02*	2.33E+02*	2.33E+02*
P-32	7.43E+09	3.47E+08	2.86E+08	NO DATA	NO DATA	NO DATA	2.05E+08
CR-51	NO DATA	NO DATA	8.78E+03	4.88E+03	1.33E+03	8.90E+03	4.66E+05
MN-54	NO DATA	8.03E+06	2.14E+06	NO DATA	2.25E+06	NO DATA	6.74E+06
FE-55	4.58E+08	2.43E+08	7.52E+07	NO DATA	NO DATA	1.37E+08	4.50E+07
FE-59	3.76E+08	6.09E+08	3.03E+08	NO DATA	NO DATA	1.76E+08	6.34E+08
CO-58	NO DATA	1.64E+07	5.03E+07	NO DATA	NO DATA	NO DATA	9.58E+07
CO-60	NO DATA	6.93E+07	2.04E+08	NO DATA	NO DATA	NO DATA	3.84E+08
NI-63	2.91E+10	1.56E+09	9.90E+08	NO DATA	NO DATA	NO DATA	1.05E+08
ZN-65	3.75E+08	1.00E+09	6.22E+08	NO DATA	6.30E+08	NO DATA	1.76E+08
RB-86	NO DATA	5.76E+08	3.54E+08	NO DATA	NO DATA	NO DATA	3.71E+07
SR-89	4.80E+08	NO DATA	1.37E+07	NO DATA	NO DATA	NO DATA	1.86E+07
SR-90	1.04E+10	NO DATA	2.64E+09	NO DATA	NO DATA	NO DATA	1.40E+08
Y-90	1.73E+02	NO DATA	4.62E+00	NO DATA	NO DATA	NO DATA	4.91E+05
Y-91	1.80E+06	NO DATA	4.81E+04	NO DATA	NO DATA	NO DATA	2.40E+08
ZR-95	2.67E+06	5.87E+05	5.22E+05	NO DATA	8.40E+05	NO DATA	6.12E+08
NB-95	3.10E+06	1.21E+06	8.61E+05	NO DATA	1.13E+06	NO DATA	2.23E+09
MO-99	NO DATA	1.14E+05	2.83E+04	NO DATA	2.44E+05	NO DATA	9.45E+04
TC-99m	6.01E-21	1.18E-20	1.95E-19	NO DATA	1.71E-19	5.98E-21	6.71E-18
RU-103	1.55E+08	NO DATA	5.96E+07	NO DATA	3.90E+08	NO DATA	4.01E+09
RU-106	4.43E+09	NO DATA	5.53E+08	NO DATA	5.99E+09	NO DATA	6.90E+10
AG-110m	8.41E+06	5.68E+06	4.54E+06	NO DATA	1.06E+07	NO DATA	6.75E+08
TE-125m	5.69E+08	1.54E+08	7.58E+07	1.60E+08	NO DATA	NO DATA	5.49E+08
TE-127m	1.77E+09	4.78E+08	2.11E+08	4.24E+08	5.06E+09	NO DATA	1.44E+09
TE-129m	1.79E+09	4.99E+08	2.77E+08	5.76E+08	5.25E+09	NO DATA	2.18E+09
I-130	2.91E-06	5.89E-06	3.03E-06	6.49E-04	8.80E-06	NO DATA	2.75E-06
I-131	1.65E+07	1.66E+07	9.46E+06	5.50E+09	2.73E+07	NO DATA	1.48E+06
I-132	1.05E-58	1.93E-58	8.86E-59	8.93E-57	2.95E-58	NO DATA	2.27E-58
I-133	5.75E-01	7.10E-01	2.69E-01	1.32E+02	1.18E+00	NO DATA	2.86E-01
I-134	0.00E+00	0.00E+00	0.00E+00	0.00E+00	0.00E+00	NO DATA	0.00E+00
I-135	6.86E-17	1.23E-16	5.83E-17	1.09E-14	1.89E-16	NO DATA	9.38E-17
CS-134	9.20E+08	1.51E+09	3.18E+08	NO DATA	4.68E+08	1.68E+08	8.14E+06
CS-136	1.62E+07	4.45E+07	2.88E+07	NO DATA	2.37E+07	3.53E+06	1.56E+06
CS-137	1.33E+09	1.27E+09	1.88E+08	NO DATA	4.15E+08	1.49E+08	7.98E+06
BA-140	4.38E+07	3.84E+04	2.56E+06	NO DATA	1.25E+04	2.29E+04	2.22E+07
CE-141	2.22E+04	1.11E+04	1.64E+03	NO DATA	4.85E+03	NO DATA	1.38E+07
CE-144	2.31E+06	7.24E+05	1.23E+05	NO DATA	4.01E+05	NO DATA	1.89E+08
PR-143	3.34E+04	1.00E+04	1.66E+03	NO DATA	5.43E+03	NO DATA	3.60E+07
ND-147	1.17E+04	9.47E+03	7.33E+02	NO DATA	5.20E+03	NO DATA	1.50E+07

\*mrem/yr per  $\mu Ci/m^3$



TABLE 3.5-26

 MEAT PATHWAY FACTORS -  $R_{ija}^M$  (TEEN)  
 ( $m^2mrem/yr$  per  $\mu Ci/sec$ )

ORGAN: ISOTOPE	BONE	LIVER	T.BODY	THYROID	KIDNEY	LUNG	GI-LLI
H-3	NO DATA	1.93E+02*	1.93E+02*	1.93E+02*	1.93E+02*	1.93E+02*	1.93E+02*
P-32	3.95E+09	2.45E+08	1.53E+08	NO DATA	NO DATA	NO DATA	3.32E+08
CR-51	NO DATA	NO DATA	5.65E+03	3.14E+03	1.24E+03	8.07E+03	9.50E+05
MN-54	NO DATA	7.02E+06	1.39E+06	NO DATA	2.09E+06	NO DATA	1.44E+07
FE-55	2.38E+08	1.69E+08	3.94E+07	NO DATA	NO DATA	1.07E+08	7.31E+07
FE-59	2.12E+08	4.95E+08	1.91E+08	NO DATA	NO DATA	1.56E+08	1.17E+09
CO-58	NO DATA	1.41E+07	3.25E+07	NO DATA	NO DATA	NO DATA	1.94E+08
CO-60	NO DATA	5.84E+07	1.32E+08	NO DATA	NO DATA	NO DATA	7.61E+08
NI-63	1.52E+10	1.07E+09	5.15E+08	NO DATA	NO DATA	NO DATA	1.71E+08
ZN-65	2.50E+08	8.69E+08	4.05E+08	NO DATA	5.56E+08	NO DATA	3.68E+08
RB-86	NO DATA	4.05E+08	1.90E+08	NO DATA	NO DATA	NO DATA	6.00E+07
SR-89	2.54E+08	NO DATA	7.27E+06	NO DATA	NO DATA	NO DATA	3.02E+07
SR-90	8.04E+09	NO DATA	1.99E+09	NO DATA	NO DATA	NO DATA	2.26E+08
Y-90	9.11E+01	NO DATA	2.45E+00	NO DATA	NO DATA	NO DATA	7.51E+05
Y-91	9.55E+05	NO DATA	2.56E+04	NO DATA	NO DATA	NO DATA	3.91E+08
ZR-95	1.50E+06	4.74E+05	3.25E+05	NO DATA	6.93E+05	NO DATA	1.09E+09
NB-95	1.79E+06	9.94E+05	5.47E+05	NO DATA	9.64E+05	NO DATA	4.25E+09
MO-99	NO DATA	8.20E+04	1.56E+04	NO DATA	1.88E+05	NO DATA	1.47E+05
TC-99m	3.42E-21	9.54E-21	1.24E-19	NO DATA	1.42E-19	5.29E-21	6.26E-18
RU-103	8.57E+07	NO DATA	3.66E+07	NO DATA	3.02E+08	NO DATA	7.16E+09
RU-106	2.36E+09	NO DATA	2.97E+08	NO DATA	4.54E+09	NO DATA	1.13E+11
AG-110m	5.04E+06	4.77E+06	2.90E+06	NO DATA	9.10E+06	NO DATA	1.34E+09
TE-125m	3.03E+08	1.09E+08	4.06E+07	8.47E+07	NO DATA	NO DATA	8.95E+08
TE-127m	9.40E+08	3.33E+08	1.12E+08	2.24E+08	3.81E+09	NO DATA	2.34E+09
TE-129m	9.49E+08	3.52E+08	1.50E+08	3.06E+08	3.97E+09	NO DATA	3.56E+09
I-130	1.63E-06	4.71E-06	1.88E-06	3.84E-04	7.25E-06	NO DATA	3.62E-06
I-131	8.89E+06	1.24E+07	6.69E+06	3.63E+09	2.14E+07	NO DATA	2.46E+06
I-132	5.78E-59	1.51E-58	5.42E-59	5.09E-57	2.38E-58	NO DATA	6.58E-59
I-133	3.09E-01	5.25E-01	1.60E-01	7.32E+01	9.20E+01	NO DATA	3.97E-01
I-134	0.00E+00	0.00E+00	0.00E+00	0.00E+00	0.00E+00	NO DATA	0.00E+00
I-135	3.79E-17	9.75E-17	3.61E-17	6.27E-15	1.54E-16	NO DATA	1.08E-16
CS-134	5.22E+08	1.23E+09	5.70E+08	NO DATA	3.91E+08	1.49E+08	1.53E+07
CS-136	9.36E+06	3.68E+07	2.47E+07	NO DATA	2.01E+07	3.16E+06	2.96E+06
CS-137	7.24E+08	9.63E+08	3.35E+08	NO DATA	3.28E+08	1.27E+08	1.37E+07
BA-140	2.37E+07	2.91E+04	1.53E+06	NO DATA	9.86E+03	1.96E+04	3.66E+07
CE-141	1.17E+04	7.83E+03	9.00E+02	NO DATA	3.69E+03	NO DATA	2.24E+07
CE-144	1.23E+06	5.10E+05	6.62E+04	NO DATA	3.04E+05	NO DATA	3.10E+08
PR-143	1.77E+04	7.06E+03	8.80E+02	NO DATA	4.10E+03	NO DATA	5.82E+07
ND-147	6.22E+03	6.76E+03	4.05E+02	NO DATA	3.97E+03	NO DATA	2.44E+07

\*mrem/yr per  $\mu Ci/m^3$

TABLE 3.5-27

 MEAT PATHWAY FACTORS -  $R_{ija}^M$  (ADULT)  
 ( $m^2$ mrem/yr per  $\mu$ Ci/sec)

ORGAN: ISOTOPE	BONE	LIVER	T.BODY	THYROID	KIDNEY	LUNG	GI-LLI
H-3	NO DATA	3.24E+02*	3.24E+02*	3.24E+02*	3.24E+02*	3.24E+02*	3.24E+02*
P-32	4.65E+09	2.89E+08	1.80E+08	NO DATA	NO DATA	NO DATA	5.23E+08
CR-51	NO DATA	NO DATA	7.05E+03	4.21E+03	1.55E+03	9.35E+03	1.77E+06
MN-54	NO DATA	9.19E+06	1.75E+06	NO DATA	2.73E+06	NO DATA	2.81E+07
FE-55	2.94E+08	2.03E+08	4.74E+07	NO DATA	NO DATA	1.13E+08	1.17E+08
FE-59	2.66E+08	6.24E+08	2.39E+08	NO DATA	NO DATA	1.74E+08	2.08E+09
CO-58	NO DATA	1.83E+07	4.09E+07	NO DATA	NO DATA	NO DATA	3.70E+08
CO-60	NO DATA	7.51E+07	1.66E+08	NO DATA	NO DATA	NO DATA	1.41E+09
NI-63	1.89E+10	1.31E+09	6.32E+08	NO DATA	NO DATA	NO DATA	2.73E+08
ZN-65	3.56E+08	1.13E+09	5.12E+08	NO DATA	7.57E+08	NO DATA	7.13E+08
RB-86	NO DATA	4.87E+08	2.27E+08	NO DATA	NO DATA	NO DATA	9.61E+07
SR-89	3.01E+08	NO DATA	8.64E+06	NO DATA	NO DATA	NO DATA	4.83E+07
SR-90	1.24E+10	NO DATA	3.05E+09	NO DATA	NO DATA	NO DATA	3.59E+08
Y-90	1.09E+02	NO DATA	2.92E+00	NO DATA	NO DATA	NO DATA	1.15E+06
Y-91	1.13E+06	NO DATA	3.03E+04	NO DATA	NO DATA	NO DATA	6.23E+08
ZR-95	1.87E+06	6.00E+05	4.06E+05	NO DATA	9.41E+05	NO DATA	1.90E+09
NB-95	2.30E+06	1.28E+06	6.86E+05	NO DATA	1.26E+06	NO DATA	7.75E+09
MO-99	NO DATA	9.91E+04	1.89E+04	NO DATA	2.24E+05	NO DATA	2.30E+05
TC-99m	4.32E-21	1.22E-20	1.56E-19	NO DATA	1.86E-19	5.99E-21	7.23E-18
RU-103	1.05E+08	NO DATA	4.53E+07	NO DATA	4.02E+08	NO DATA	1.23E+10
RU-106	2.81E+09	NO DATA	3.55E+08	NO DATA	5.42E+09	NO DATA	1.82E+11
AG-110m	6.67E+06	6.17E+06	3.67E+06	NO DATA	1.21E+07	NO DATA	2.52E+09
TE-125m	3.59E+08	1.30E+08	4.81E+07	1.08E+08	1.46E+09	NO DATA	1.43E+09
TE-127m	1.12E+09	3.99E+08	1.36E+08	2.85E+08	4.54E+09	NO DATA	3.75E+09
TE-129m	1.13E+09	4.22E+08	1.79E+08	3.89E+08	4.73E+09	NO DATA	5.70E+09
I-130	2.03E-06	5.98E-06	2.36E-06	5.07E-04	9.33E-06	NO DATA	5.15E-06
I-131	1.07E+07	1.54E+07	8.80E+06	5.03E+09	2.63E+07	NO DATA	4.05E+06
I-132	7.13E-59	1.91E-58	6.67E-59	6.67E-57	3.04E-58	NO DATA	3.58E-59
I-133	3.70E-01	6.43E-01	1.96E-01	9.45E+01	1.12E+00	NO DATA	5.78E-01
I-134	0.00E+00	0.00E+00	0.00E+00	0.00E+00	0.00E+00	NO DATA	0.00E+00
I-135	4.65E-17	1.22E-16	4.49E-17	8.03E-15	1.95E-16	NO DATA	1.38E-16
CS-134	6.53E+08	1.55E+09	1.27E+09	NO DATA	5.03E+08	1.67E+08	2.72E+07
CS-136	1.20E+07	4.75E+07	3.42E+07	NO DATA	2.65E+07	3.63E+06	5.40E+06
CS-137	8.69E+08	1.19E+09	7.78E+08	NO DATA	4.03E+08	1.34E+08	2.30E+07
BA-140	2.88E+07	3.62E+04	1.89E+06	NO DATA	1.23E+04	2.07E+04	5.94E+07
CE-141	1.39E+04	9.43E+03	1.07E+03	NO DATA	4.38E+03	NO DATA	3.61E+07
CE-144	1.46E+06	6.10E+05	7.83E+04	NO DATA	3.62E+05	NO DATA	4.93E+08
PR-143	2.09E+04	8.40E+03	1.04E+03	NO DATA	4.85E+03	NO DATA	9.17E+07
ND-147	7.04E+03	8.14E+03	4.87E+02	NO DATA	4.76E+03	NO DATA	3.91E+07

\*mrem/yr per  $\mu$ Ci/m<sup>3</sup>

TABLE 3.5-28

 VEGETATION PATHWAY FACTORS -  $R_{ija}^V$  (CHILD)  
 ( $m^2$ mrem/yr per  $\mu$ Ci/sec)

ORGAN: ISOTOPE	BONE	LIVER	T.BODY	THYROID	KIDNEY	LUNG	GI-LLI
H-3	NO DATA	4.01E+03*	4.01E+03*	4.01E+03*	4.01E+03*	4.01E+03*	4.01E+03*
P-32	3.37E+09	1.57E+08	1.30E+08	NO DATA	NO DATA	NO DATA	9.30E+07
CR-51	NO DATA	NO DATA	1.17E+05	6.49E+04	1.77E+04	1.18E+05	6.20E+06
MN-54	NO DATA	6.64E+08	1.77E+08	NO DATA	1.86E+08	NO DATA	5.58E+08
FE-55	8.02E+08	4.25E+08	1.32E+08	NO DATA	NO DATA	2.40E+08	7.88E+07
FE-59	3.98E+08	6.43E+08	3.21E+08	NO DATA	NO DATA	1.87E+08	6.70E+08
CO-58	NO DATA	6.44E+07	1.97E+08	NO DATA	NO DATA	NO DATA	3.76E+08
CO-60	NO DATA	3.79E+08	1.12E+09	NO DATA	NO DATA	NO DATA	2.10E+09
NI-63	3.95E+10	2.11E+09	1.34E+09	NO DATA	NO DATA	NO DATA	1.42E+08
ZN-65	8.11E+08	2.16E+09	1.34E+09	NO DATA	1.36E+09	NO DATA	3.79E+08
RB-86	NO DATA	4.53E+08	2.79E+08	NO DATA	NO DATA	NO DATA	2.91E+07
SR-89	3.59E+10	NO DATA	1.03E+09	NO DATA	NO DATA	NO DATA	1.39E+09
SR-90	1.24E+12	NO DATA	3.14E+11	NO DATA	NO DATA	NO DATA	1.67E+10
Y-90	2.31E+04	NO DATA	6.18E+02	NO DATA	NO DATA	NO DATA	6.58E+07
Y-91	1.86E+07	NO DATA	4.97E+05	NO DATA	NO DATA	NO DATA	2.48E+09
ZR-95	3.86E+06	8.49E+05	7.56E+05	NO DATA	1.22E+06	NO DATA	8.86E+08
NB-95	4.10E+05	1.60E+05	1.14E+05	NO DATA	1.50E+05	NO DATA	2.95E+08
MO-99	NO DATA	7.67E+06	1.90E+06	NO DATA	1.64E+07	NO DATA	6.35E+06
TC-99m	4.70E+00	9.21E+00	1.53E+02	NO DATA	1.34E+02	4.68E+00	5.24E+03
RU-103	1.54E+07	NO DATA	5.90E+06	NO DATA	3.86E+07	NO DATA	3.97E+08
RU-106	7.45E+08	NO DATA	9.30E+07	NO DATA	1.01E+09	NO DATA	1.16E+10
AG-110m	3.21E+07	2.17E+07	1.73E+07	NO DATA	4.04E+07	NO DATA	2.58E+09
TE-125m	3.51E+08	9.52E+07	4.68E+07	9.86E+07	NO DATA	NO DATA	3.39E+08
TE-127m	1.32E+09	3.56E+08	1.57E+08	3.16E+08	3.77E+09	NO DATA	1.07E+09
TE-129m	8.43E+08	2.35E+08	1.31E+08	2.72E+08	2.47E+09	NO DATA	1.03E+09
I-130	6.10E+05	1.23E+06	6.35E+05	1.36E+08	1.84E+06	NO DATA	5.77E+05
I-131	1.43E+08	1.44E+08	8.16E+07	4.75E+10	2.36E+08	NO DATA	1.28E+07
I-132	9.20E+01	1.69E+02	7.77E+01	7.84E+03	2.59E+02	NO DATA	1.99E+02
I-133	3.53E+06	4.36E+06	1.65E+06	8.11E+08	7.27E+06	NO DATA	1.76E+06
I-134	1.50E-04	2.79E-04	1.28E-04	6.41E-03	4.26E-04	NO DATA	1.85E-04
I-135	6.28E+04	1.13E+05	5.34E+04	1.00E+07	1.73E+05	NO DATA	8.61E+04
CS-134	1.60E+10	2.63E+10	5.55E+09	NO DATA	8.15E+09	2.92E+09	1.42E+08
CS-136	8.23E+07	2.26E+08	1.46E+08	NO DATA	1.20E+08	1.80E+07	7.95E+06
CS-137	2.39E+10	2.29E+10	3.38E+09	NO DATA	7.46E+09	2.68E+09	1.43E+08
BA-140	2.77E+08	2.42E+05	1.62E+07	NO DATA	7.89E+04	1.45E+05	1.40E+08
CE-141	6.56E+05	3.27E+05	4.85E+04	NO DATA	1.43E+05	NO DATA	4.08E+08
CE-144	1.27E+08	3.99E+07	6.79E+06	NO DATA	2.21E+07	NO DATA	1.04E+10
PR-143	1.45E+05	4.37E+04	7.22E+03	NO DATA	2.36E+04	NO DATA	1.57E+08
ND-147	7.16E+04	5.80E+04	4.49E+03	NO DATA	3.18E+04	NO DATA	9.18E+07

\*mrem/yr per  $\mu$ Ci/m<sup>3</sup>

TABLE 3.5-29

VEGETATION PATHWAY FACTORS -  $R_{ija}^V$  (TEEN)  
 $(m^2 mrem/yr \text{ per } \mu Ci/sec)$

ORGAN: ISOTOPE	BONE	LIVER	T.BODY	THYROID	KIDNEY	LUNG	GI-LLI
H-3	NO DATA	2.59E+03*	2.59E+03*	2.59E+03*	2.59E+03*	2.59E+03*	2.59E+03*
P-32	1.61E+09	9.97E+07	6.24E+07	NO DATA	NO DATA	NO DATA	1.35E+08
CR-51	NO DATA	NO DATA	6.12E+04	3.40E+04	1.34E+04	8.74E+04	1.03E+07
MN-54	NO DATA	4.54E+08	9.01E+07	NO DATA	1.36E+08	NO DATA	9.32E+08
FE-55	3.26E+08	2.31E+08	5.39E+07	NO DATA	NO DATA	1.46E+08	1.00E+08
FE-59	1.79E+08	4.18E+08	1.61E+08	NO DATA	NO DATA	1.32E+08	9.88E+08
CO-58	NO DATA	4.36E+07	1.01E+08	NO DATA	NO DATA	NO DATA	6.02E+08
CO-60	NO DATA	2.49E+08	5.60E+08	NO DATA	NO DATA	NO DATA	3.24E+09
NI-63	1.61E+10	1.14E+09	5.46E+08	NO DATA	NO DATA	NO DATA	1.81E+08
ZN-65	4.23E+08	1.47E+09	6.86E+08	NO DATA	9.41E+08	NO DATA	6.23E+08
RB-86	NO DATA	2.72E+08	1.28E+08	NO DATA	NO DATA	NO DATA	4.02E+07
SR-89	1.51E+10	NO DATA	4.32E+08	NO DATA	NO DATA	NO DATA	1.80E+09
SR-90	7.50E+11	NO DATA	1.85E+11	NO DATA	NO DATA	NO DATA	2.11E+10
Y-90	1.25E+04	NO DATA	3.37E+02	NO DATA	NO DATA	NO DATA	1.03E+08
Y-91	7.84E+06	NO DATA	2.10E+05	NO DATA	NO DATA	NO DATA	3.21E+09
ZR-95	1.73E+06	5.46E+05	3.75E+05	NO DATA	8.02E+05	NO DATA	1.26E+09
NB-95	1.92E+05	1.07E+05	5.86E+04	NO DATA	1.03E+05	NO DATA	4.56E+08
MO-99	NO DATA	5.64E+06	1.08E+06	NO DATA	1.29E+07	NO DATA	1.01E+07
TC-99m	2.73E+00	7.61E+00	9.86E+01	NO DATA	1.13E+02	4.23E+00	5.00E+03
RU-103	6.81E+06	NO DATA	2.91E+06	NO DATA	2.40E+07	NO DATA	5.69E+08
RU-106	3.09E+08	NO DATA	3.89E+07	NO DATA	5.95E+08	NO DATA	1.48E+10
AG-110m	1.51E+07	1.43E+07	8.72E+06	NO DATA	2.72E+07	NO DATA	4.03E+09
TE-125m	1.49E+08	5.35E+07	1.99E+07	4.15E+07	NO DATA	NO DATA	4.38E+08
TE-127m	5.52E+08	1.96E+08	6.57E+07	1.31E+08	2.24E+09	NO DATA	1.38E+09
TE-129m	3.60E+08	1.34E+08	5.70E+07	1.16E+08	1.51E+09	NO DATA	1.35E+09
I-130	3.50E+05	1.01E+06	4.05E+05	8.26E+07	1.56E+06	NO DATA	7.79E+05
I-131	7.66E+07	1.07E+08	5.76E+07	3.13E+10	1.85E+08	NO DATA	2.12E+07
I-132	5.19E+01	1.36E+02	4.87E+01	4.58E+03	2.14E+02	NO DATA	5.91E+01
I-133	1.93E+06	3.28E+06	1.00E+06	4.58E+08	5.75E+06	NO DATA	2.48E+06
I-134	8.44E-05	2.24E-04	8.03E-05	3.73E-03	3.53E-04	NO DATA	2.95E-06
I-135	3.53E+04	9.09E+04	3.37E+04	5.85E+06	1.44E+05	NO DATA	1.01E+05
CS-134	7.10E+09	1.67E+10	7.75E+09	NO DATA	5.31E+09	2.03E+09	2.08E+08
CS-136	4.37E+07	1.72E+08	1.16E+08	NO DATA	9.37E+07	1.48E+07	1.38E+07
CS-137	1.01E+10	1.35E+10	4.70E+09	NO DATA	4.59E+09	1.78E+09	1.92E+08
BA-140	1.38E+08	1.69E+05	8.89E+06	NO DATA	5.73E+04	1.14E+05	2.13E+08
CE-141	2.83E+05	1.89E+05	2.17E+04	NO DATA	8.90E+04	NO DATA	5.41E+08
CE-144	5.29E+07	2.19E+07	2.84E+06	NO DATA	1.31E+07	NO DATA	1.33E+10
PR-143	7.00E+04	2.79E+04	3.48E+03	NO DATA	1.62E+04	NO DATA	2.30E+08
ND-147	3.62E+04	3.94E+04	2.36E+03	NO DATA	2.31E+04	NO DATA	1.42E+08

\*mrem/yr per  $\mu Ci/m^3$

TABLE 3.5-30

 VEGETATION PATHWAY FACTORS -  $R_{ija}^V$  (ADULT)  
 ( $m^2mrem/yr$  per  $\mu Ci/sec$ )

ORGAN: ISOTOPE	BONE	LIVER	T.BODY	THYROID	KIDNEY	LUNG	GI-LLI
H-3	NO DATA	2.26E+03*	2.26E+03*	2.26E+03*	2.26E+03*	2.26E+03*	2.26E+03*
P-32	1.40E+09	8.70E+07	5.41E+07	NO DATA	NO DATA	NO DATA	1.57E+08
CR-51	NO DATA	NO DATA	4.60E+04	2.75E+04	1.01E+04	6.11E+04	1.16E+07
MN-54	NO DATA	3.13E+08	5.96E+07	NO DATA	9.30E+07	NO DATA	9.58E+08
FE-55	2.10E+08	1.45E+08	3.38E+07	NO DATA	NO DATA	8.10E+07	8.33E+07
FE-59	1.26E+08	2.96E+08	1.13E+08	NO DATA	NO DATA	8.27E+07	9.86E+08
CO-58	NO DATA	3.08E+07	6.90E+07	NO DATA	NO DATA	NO DATA	6.24E+08
CO-60	NO DATA	1.67E+08	3.69E+08	NO DATA	NO DATA	NO DATA	3.14E+09
NI-63	1.04E+10	7.21E+08	3.49E+08	NO DATA	NO DATA	NO DATA	1.50E+08
ZN-65	3.18E+08	1.01E+09	4.57E+08	NO DATA	6.76E+08	NO DATA	6.36E+08
RB-86	NO DATA	2.19E+08	1.02E+08	NO DATA	NO DATA	NO DATA	4.33E+07
SR-89	9.95E+09	NO DATA	2.86E+08	NO DATA	NO DATA	NO DATA	1.60E+09
SR-90	6.04E+11	NO DATA	1.48E+11	NO DATA	NO DATA	NO DATA	1.75E+10
Y-90	1.33E+04	NO DATA	3.56E+02	NO DATA	NO DATA	NO DATA	1.41E+08
Y-91	5.12E+06	NO DATA	1.37E+05	NO DATA	NO DATA	NO DATA	2.82E+09
ZR-95	1.18E+06	3.79E+05	2.56E+05	NO DATA	5.94E+05	NO DATA	1.20E+09
NB-95	1.42E+05	7.91E+04	4.25E+04	NO DATA	7.82E+04	NO DATA	4.80E+08
MO-99	NO DATA	6.12E+06	1.16E+06	NO DATA	1.39E+07	NO DATA	1.42E+07
TC-99m	3.09E+00	8.73E+00	1.11E+02	NO DATA	1.33E+02	4.28E+00	5.16E+03
RU-103	4.77E+06	NO DATA	2.06E+06	NO DATA	1.82E+07	NO DATA	5.57E+08
RU-106	1.93E+08	NO DATA	2.44E+07	NO DATA	3.73E+08	NO DATA	1.25E+10
AG-110m	1.05E+07	9.75E+06	5.79E+06	NO DATA	1.92E+07	NO DATA	3.98E+09
TE-125m	9.67E+07	3.51E+07	1.30E+07	2.91E+07	3.93E+08	NO DATA	3.86E+08
TE-127m	3.49E+08	1.25E+08	4.26E+07	8.93E+07	1.42E+09	NO DATA	1.17E+09
TE-129m	2.51E+08	9.35E+07	3.97E+07	8.61E+07	1.05E+09	NO DATA	1.26E+09
I-130	3.91E+05	1.15E+06	4.55E+05	9.77E+07	1.80E+06	NO DATA	9.93E+05
I-131	8.07E+07	1.15E+08	6.62E+07	3.78E+10	1.98E+08	NO DATA	3.05E+07
I-132	5.77E+01	1.54E+02	5.40E+01	5.40E+03	2.46E+02	NO DATA	2.90E+01
I-133	2.09E+06	3.63E+06	1.11E+06	5.34E+08	6.34E+06	NO DATA	3.26E+06
I-134	9.33E-05	2.53E-04	9.06E-05	4.39E-03	4.03E-04	NO DATA	2.12E-07
I-135	3.91E+04	1.02E+05	3.77E+04	6.75E+06	1.64E+05	NO DATA	1.16E+05
CS-134	4.67E+09	1.11E+10	9.08E+09	NO DATA	3.59E+09	1.19E+09	1.94E+08
CS-136	4.26E+07	1.68E+08	1.21E+08	NO DATA	9.35E+07	1.28E+07	1.91E+07
CS-137	6.36E+09	8.70E+09	5.70E+09	NO DATA	2.95E+09	9.82E+08	1.68E+08
BA-140	1.29E+08	1.62E+05	8.43E+06	NO DATA	5.50E+04	9.26E+04	2.65E+08
CE-141	1.97E+05	1.33E+05	1.51E+04	NO DATA	6.19E+04	NO DATA	5.09E+08
CE-144	3.28E+07	1.37E+07	1.76E+06	NO DATA	8.14E+06	NO DATA	1.11E+10
PR-143	6.26E+04	2.51E+04	3.10E+03	NO DATA	1.45E+04	NO DATA	2.74E+08
ND-147	3.33E+04	3.85E+04	2.31E+03	NO DATA	2.25E+04	NO DATA	1.85E+08

\*mrem/yr per  $\mu Ci/m^3$

TABLE 3.5-31

GROUND PLANE PATHWAY FACTORS -  $R_i^G$   
 ( $m^2mrem/yr$  per  $\mu Ci/sec$ )

ISOTOPE	TOTAL BODY	SKIN	ISOTOPE	TOTAL BODY	SKIN
H-3	0.00E+00	0.00E+00	ZR-95	2.45E+08	2.85E+08
P-32	0.00E+00	0.00E+00	NB-95	1.37E+08	1.61E+08
CR-51	4.65E+06	5.50E+06	TC-99m	1.84E+05	2.11E+05
MN-54	1.38E+09	1.62E+09	RU-103	1.08E+08	1.26E+08
MO-99	3.99E+06	4.62E+06	RU-106	4.22E+08	5.06E+08
FE-55	0.00E+00	0.00E+00	TE-127m	9.16E+04	1.08E+05
FE-59	2.73E+08	3.20E+08	I-131	1.72E+07	2.09E+07
CO-58	3.80E+08	4.45E+08	I-132	1.25E+06	1.47E+06
CO-60	2.32E+10	2.73E+10	I-135	2.53E+06	2.95E+06
NI-63	0.00E+00	0.00E+00	CS-134	6.87E+09	8.01E+09
AG-110m	3.44E+09	4.01E+09	CS-136	1.51E+08	1.71E+08
TE-125m	1.56E+06	2.13E+06	BA-140	2.05E+07	2.35E+07
ZN-65	7.48E+08	8.60E+08	CE-141	1.37E+07	1.54E+07
TE-129m	1.98E+07	2.31E+07	CE-144	6.96E+07	8.05E+07
RB-86	8.98E+06	1.03E+07	PR-143	0.00E+00	0.00E+00
I-130	5.50E+06	6.68E+06	ND-147	8.39E+06	1.01E+07
SR-89	2.16E+04	2.50E+04			
SR-90	NO DATA	NO DATA			
I-133	2.45E+06	2.98E+06			
I-134	4.46E+05	5.30E+05			
Y-90	4.50E+03	5.31E+03			
Y-91	1.07E+06	1.21E+06			

4.0 COMPLIANCE WITH 40CFR190

4.1 Total Dose - Operation and Surveillance Requirements

OPERATION REQUIREMENT

---

The annual (calendar year) dose or dose commitment to any MEMBER OF THE PUBLIC due to releases of radioactivity and to radiation from uranium fuel cycle sources shall be limited to less than or equal to 25 mrem to the total body or any organ, except the thyroid, which shall be limited to less than or equal to 75 mrem. This requirement is applicable at all times.

REMEDIAL REQUIREMENT:

a. With the calculated doses from the release of radioactive materials in liquid or gaseous effluents exceeding twice the limits of Sections 2.4.1(a), 2.4.1(b), 3.5.1(a), 3.5.1(b), 3.5.2(a), and 3.5.2(b), calculations shall be made including direct radiation contributions from the reactor unit and from outside storage tanks to determine whether the above limits of Section 4.1 have been exceeded. If such is the case, prepare and submit to the Regional Administrator of the Regional Office of the NRC within 30 days a Special Report that defines the corrective action to be taken to reduce subsequent releases to prevent recurrence of exceeding the above limits and includes the schedule for achieving conformance with the above limits. This Special Report, as defined in 10CFR20 Part 2203(4), shall include the following information:

1. An estimate of each individuals dose.
2. The levels of radiation and concentrations of radioactive material involved.
3. The cause of the elevated exposures, dose rates, or concentrations.
4. Corrective steps taken or planned to ensure against a recurrence, including the schedule for achieving conformance with applicable limits, ALARA constraints, generally applicable environmental standards, and associated license conditions.

SURVEILLANCE REQUIREMENTS

---

- 4.1.1 Cumulative dose contributions from liquid and gaseous effluents shall be determined in accordance with Sections 2.4.1.1, 3.5.1.1, and 3.5.2.1, and in accordance with the methodology and parameters described or specified in this manual.
- 4.1.2 Cumulative dose contributions from direct radiation from the reactor and from radwaste storage tanks shall be determined in accordance with the methodology and parameters described or specified in this manual. This requirement is applicable only under conditions set forth in the Remedial Requirement specified above (Section 4.1).

#The total body and organ doses resulting from liquid effluents will be summed with the doses resulting from gaseous effluents (including non-noble gases) and the doses to the maximum exposed individual from other operations of the uranium fuel cycle. The effluent doses will be based upon releases from CPS during the previous three quarters and from the quarter in which the Section 4.1 OPERATION REQUIREMENT was exceeded.



5.0 RADIOLOGICAL ENVIRONMENTAL MONITORING PROGRAM

The primary requirements for the Clinton Power Station Radiological Environmental Monitoring Program (REMP) are set forth in Table 5.1-1 and shown by location in Figures 5.0-1, 5.0-2, 5.0-3 and 5.0-4.

In addition to the required sampling program, CPS will perform supplemental periodic and long term sampling and analyses in order to better monitor environmental exposure pathways. These samples will not be listed in this manual.

5.1 Monitoring Program - Operation and Surveillance Requirements

OPERATION REQUIREMENT

The Radiological Environmental Monitoring Program shall be conducted as specified in Table 5.1-1. This requirement applies at all times.

REMEDIAL REQUIREMENT:

- a. With the radiological environmental monitoring program not being conducted as specified in Table 5.1-1 prepare and submit to the Commission, in the Annual Radiological Environmental Operating Report required by Technical Specification 5.6.2, a description of the reasons for not conducting the program as required and the plans for preventing a recurrence.
- b. With the level of radioactivity as the result of plant effluents in an environmental sampling medium at a specified location exceeding the report levels of Table 5.1-2 when averaged over any calendar quarter prepare and submit to the Regional Administrator of the Regional Office of the NRC within 30 days a Special Report that identifies the cause(s) for exceeding the limit(s) and defines the corrective actions to be taken to reduce radioactive effluents so that the potential annual dose to a MEMBER OF THE PUBLIC is less than the calendar year limits of Section 2.4.1, 3.5.1, and 3.5.2. When more than one of the radionuclides in Table 5.1-2 are detected in the sampling medium, this report shall be submitted if:

$$\frac{\text{concentration (1)}}{\text{reporting level (1)}} + \frac{\text{concentration (2)}}{\text{reporting level (2)}} + >1.0$$

When radionuclides other than those in Table 5.1-2 are detected and the result of plant effluents, this report shall be submitted if the potential annual dose\* to a MEMBER OF THE PUBLIC is equal to or greater than the calendar year limits of Section 2.4.1, 3.5.1, and 3.5.2. This report is not required if the measured level of radioactivity was not the result of plant effluents; however, in such an event, the condition shall be reported and described in the Annual Radiological Environmental Operating Report.

The methodology and parameters used to estimate the potential annual dose to a MEMBER OF THE PUBLIC shall be indicated in this report.

- c. With milk or fresh leafy vegetation samples unavailable from one or more of the sample locations required by Table 5.1-1, identify locations for obtaining replacement samples and add them to the radiological environmental monitoring program within 30 days. The specific locations from which samples were unavailable may then be deleted from the monitoring program. Pursuant to Technical Specification 5.5.1, identify the cause of the unavailability of samples and identify the new location(s) for obtaining replacement samples in the next annual Radiological Environmental Operating Report and also include in the report a revised figure(s) and table for this manual reflecting the new location(s).

#### SURVEILLANCE REQUIREMENTS

- 5.1.1 The radiological environmental monitoring samples shall be collected pursuant to Table 5.1-1 from the specific locations given in Table 5.1-1 and Figures 5.0-1, 5.0-2, 5.0-3, and 5.0-4 and shall be analyzed pursuant to the requirements of Table 5.1-1 and the detection capabilities required by Table 5.1-3.

TABLE 5.1-1

RADIOLOGICAL ENVIRONMENTAL MONITORING PROGRAM

<u>EXPOSURE PATHWAY AND/OR SAMPLE</u>	<u>NUMBER OF REPRESENTATIVE SAMPLES AND SAMPLE LOCATIONS<sup>a</sup></u>	<u>SAMPLING AND COLLECTION FREQUENCY</u>	<u>TYPE AND FREQUENCY OF ANALYSIS</u>																																																			
1. DIRECT RADIATION <sup>b</sup>	40 routine monitoring stations either with two or more dosimeters or with one instrument for measuring and recording dose rate continuously, placed as follows:  (1) an inner ring of stations, one in each meteorological sector in the general area of the SITE BOUNDARY;	Quarterly	Gamma dose quarterly																																																			
	<table border="1"> <thead> <tr> <th><u>SECTOR</u></th> <th><u>CODE</u></th> <th><u>DISTANCE from station (miles)</u></th> </tr> </thead> <tbody> <tr><td>N</td><td>CL-36</td><td>0.6</td></tr> <tr><td>NNE</td><td>CL-5</td><td>0.7</td></tr> <tr><td>NE</td><td>CL-22</td><td>0.6</td></tr> <tr><td>ENE</td><td>CL-23</td><td>0.5</td></tr> <tr><td>E</td><td>CL-24</td><td>0.5</td></tr> <tr><td>ESE</td><td>CL-42</td><td>2.8</td></tr> <tr><td>SE</td><td>CL-43</td><td>2.8</td></tr> <tr><td>SSE</td><td>CL-44</td><td>2.3</td></tr> <tr><td>S</td><td>CL-45</td><td>2.8</td></tr> <tr><td>SSW</td><td>CL-46</td><td>2.8</td></tr> <tr><td>SW</td><td>CL-47</td><td>3.3</td></tr> <tr><td>WSW</td><td>CL-48</td><td>2.3</td></tr> <tr><td>W</td><td>CL-1</td><td>1.8</td></tr> <tr><td>WNW</td><td>CL-34</td><td>0.8</td></tr> <tr><td>NW</td><td>CL-35</td><td>0.7</td></tr> <tr><td>NNW</td><td>CL-63</td><td>1.3</td></tr> </tbody> </table>	<u>SECTOR</u>	<u>CODE</u>	<u>DISTANCE from station (miles)</u>	N	CL-36	0.6	NNE	CL-5	0.7	NE	CL-22	0.6	ENE	CL-23	0.5	E	CL-24	0.5	ESE	CL-42	2.8	SE	CL-43	2.8	SSE	CL-44	2.3	S	CL-45	2.8	SSW	CL-46	2.8	SW	CL-47	3.3	WSW	CL-48	2.3	W	CL-1	1.8	WNW	CL-34	0.8	NW	CL-35	0.7	NNW	CL-63	1.3		
<u>SECTOR</u>	<u>CODE</u>	<u>DISTANCE from station (miles)</u>																																																				
N	CL-36	0.6																																																				
NNE	CL-5	0.7																																																				
NE	CL-22	0.6																																																				
ENE	CL-23	0.5																																																				
E	CL-24	0.5																																																				
ESE	CL-42	2.8																																																				
SE	CL-43	2.8																																																				
SSE	CL-44	2.3																																																				
S	CL-45	2.8																																																				
SSW	CL-46	2.8																																																				
SW	CL-47	3.3																																																				
WSW	CL-48	2.3																																																				
W	CL-1	1.8																																																				
WNW	CL-34	0.8																																																				
NW	CL-35	0.7																																																				
NNW	CL-63	1.3																																																				

TABLE 5.1-1 (Continued)

RADIOLOGICAL ENVIRONMENTAL MONITORING PROGRAM

<u>EXPOSURE PATHWAY AND/OR SAMPLE</u>	<u>NUMBER OF REPRESENTATIVE SAMPLES AND SAMPLE LOCATIONS<sup>a</sup></u>	<u>SAMPLING AND COLLECTION FREQUENCY</u>	<u>TYPE AND FREQUENCY OF ANALYSIS</u>
1. DIRECT RADIATION <sup>b</sup> (continued)	(2) an outer ring of stations, one in each meteorological sector in the 6 to 8 km (3.7 miles to 5.0 miles) range from the site;		
	<u>SECTOR</u>	<u>CODE</u>	<u>DISTANCE from station (miles)</u>
	N	CL-76	4.6
	NNE	CL-77	4.5
	NE	CL-78	4.8
	ENE	CL-79	4.5
	E	CL-53	4.3
	ESE	CL-54	4.6
	SE	CL-55	4.1
	SSE	CL-56	4.1
	S	CL-57	4.6
	SSW	CL-58	4.3
	SW	CL-60	4.5
	WSW	CL-61	4.5
	W	CL-80	4.1
	WNW	CL-81	4.5
	NW	CL-51	4.4
	NNW	CL-52	4.3

TABLE 5.1-1 (Continued)

RADIOLOGICAL ENVIRONMENTAL MONITORING PROGRAM

<u>EXPOSURE PATHWAY AND/OR SAMPLE</u>	<u>NUMBER OF REPRESENTATIVE SAMPLES AND SAMPLE LOCATIONS<sup>a</sup></u>	<u>SAMPLING AND COLLECTION FREQUENCY</u>	<u>TYPE AND FREQUENCY OF ANALYSIS</u>
1. DIRECT RADIATION <sup>b</sup> (continued)	(3) the balance of the stations to be placed in special interest areas such as population centers, nearby residences, schools, and in 1 or 2 areas to serve as control stations.		
	<u>SECTOR</u>	<u>CODE</u>	<u>DISTANCE from station (miles)</u>
	N	CL-37	3.4
	N	CL-75	0.9
	ENE	CL-65	2.6
	E	CL-41	2.4
	S(control)	CL-11	16
	W	CL-49	3.5
	W	CL-74	1.9
	WNW	CL-64	2.1

TABLE 5.1-1 (Continued)

RADIOLOGICAL ENVIRONMENTAL MONITORING PROGRAM

<u>EXPOSURE PATHWAY AND/OR SAMPLE</u>	<u>NUMBER OF REPRESENTATIVE SAMPLES AND SAMPLE LOCATIONS<sup>a</sup></u>	<u>SAMPLING AND COLLECTION FREQUENCY</u>	<u>TYPE AND FREQUENCY OF ANALYSIS</u>
2. AIRBORNE			
Radioiodine and Particulates	Samples from 5 locations: a. 3 samples from close to the 3 SITE BOUNDARY locations in different sectors of the highest calculated annual average ground-level D/Q.	Continuous sampler operations with sample collection weekly, or more frequently if required by dust loading.	<u>Radioiodine Canister: I- 131 analysis weekly.</u>  <u>Particulate Sampler:</u> Gross beta radioactivity analysis following filter change <sup>d</sup> ; Gamma isotopic analysis <sup>e</sup> of composite (by location) quarterly.

<u>SECTOR</u>	<u>CODE</u>	<u>DISTANCE from station (miles)</u>
NNE	CL-2	0.7
NE	CL-3	0.7
N	CL-15	0.9

- b. 1 sample from the vicinity  
of a community having the  
highest calculated annual  
average ground-level D/Q.

<u>SECTOR</u>	<u>CODE</u>	<u>DISTANCE from station (miles)</u>
E	CL-8	2.2

TABLE 5.1-1 (Continued)

RADIOLOGICAL ENVIRONMENTAL MONITORING PROGRAM

<u>EXPOSURE PATHWAY AND/OR SAMPLE</u>	<u>NUMBER OF REPRESENTATIVE SAMPLES AND SAMPLE LOCATIONS<sup>a</sup></u>	<u>SAMPLING AND COLLECTION FREQUENCY</u>	<u>TYPE AND FREQUENCY OF ANALYSIS</u>
2. AIRBORNE (continued)	c. 1 sample from a control location, as for example 15-30 km (9.3 miles to 18.6 miles) distant and in the least prevalent wind direction <sup>c</sup> .		
	<u>SECTOR</u> S (control)	<u>CODE</u> CL-11	<u>DISTANCE from station (miles)</u> 16
3. WATERBORNE a. Surface <sup>f</sup>	1 sample upstream 1 sample downstream	Composite sample over 1 month period <sup>g</sup>	Gamma isotopic analysis <sup>e</sup> monthly. Composite for tritium analysis quarterly.
	<u>SECTOR</u> ENE (upstream) SE (downstream)	<u>CODE</u> CL-91 CL-90	<u>DISTANCE from station (miles)</u> 6.1 0.4



TABLE 5.1-1 (Continued)

RADIOLOGICAL ENVIRONMENTAL MONITORING PROGRAM

<u>EXPOSURE PATHWAY AND/OR SAMPLE</u>	<u>NUMBER OF REPRESENTATIVE SAMPLES AND SAMPLE LOCATIONS<sup>a</sup></u>	<u>SAMPLING AND COLLECTION FREQUENCY</u>	<u>TYPE AND FREQUENCY OF ANALYSIS</u>
3. WATERBORNE (continued)			
b. Ground	Samples from 1 or 2 sources, only if likely to be affected <sup>h</sup> .	Quarterly	Gamma isotopic <sup>e</sup> and tritium analysis quarterly.
	<u>SECTOR</u>	<u>CODE</u>	<u>DISTANCE from station (miles)</u>
	E	CL-12	1.6*
	ESE	CL-7D	2.3
	*Sample location is in pump station distant from well. Well located 1.0 mile S of plant on the edge of the lake.		
c. Drinking	1 sample of each of 1 to 3 of the nearest water supplies that could be affected by its discharge.*	Composite sample over 2-week period <sup>g</sup> when I-131 analysis is performed, monthly composite otherwise.	I-131 analysis on each composite when the dose calculated for the consumption of the water is greater than 1 mrem per year. <sup>i</sup> Composite for gross beta and gamma isotopic analyses <sup>e</sup> monthly. Composite for tritium analysis quarterly.
	<u>SECTOR</u>	<u>CODE</u>	<u>DISTANCE from station (miles)</u>
	WNW	CL-14	within Service Building
	*No municipal or public drinking water supplies are taken from Clinton Lake or downstream for 200 miles. Drinking water for Clinton Power Station is supplied by Clinton Lake.		
	1 sample from a control location**		
	**No control location necessary		

TABLE 5.1-1 (Continued)

RADIOLOGICAL ENVIRONMENTAL MONITORING PROGRAM

<u>EXPOSURE PATHWAY AND/OR SAMPLE</u>	<u>NUMBER OF REPRESENTATIVE SAMPLES AND SAMPLE LOCATIONS<sup>a</sup></u>	<u>SAMPLING AND COLLECTION FREQUENCY</u>	<u>TYPE AND FREQUENCY OF ANALYSIS</u>
3. WATERBORNE (continued)			
d. Sediment from shoreline	1 sample from downstream area with existing or potential recreational value.	Semiannually	Gamma isotopic analysis <sup>e</sup> semiannually.
	<u>SECTOR</u> SE	<u>CODE</u> CL-7B	<u>DISTANCE from station (miles)</u> 2.1
4. INGESTION			
a. Milk	Samples from milking animals in 3 locations within 5-km distance having the highest dose potential. If there are none, 1 sample from milking animals in each of 3 areas between 5 to 8 km distant where doses are calculated to be in greater than 1 mrem per year. <sup>k*</sup>	Semimonthly when animals are on pasture, monthly at other times	Gamma isotopic <sup>e</sup> and I-131 analysis semimonthly when animals are on pasture; monthly at other times.
	*This sample requirement is checked annually as part of the annual land use survey.		

TABLE 5.1-1 (Continued)

RADIOLOGICAL ENVIRONMENTAL MONITORING PROGRAM

<u>EXPOSURE PATHWAY AND/OR SAMPLE</u>	<u>NUMBER OF REPRESENTATIVE SAMPLES AND SAMPLE LOCATIONS<sup>a</sup></u>	<u>SAMPLING AND COLLECTION FREQUENCY</u>	<u>TYPE AND FREQUENCY OF ANALYSIS</u>
4. INGESTION (continued)			
a. Milk (continued)	1 sample from milking animals at a control location, 15-30 km (9.3 miles to 18.6 miles) distant and in the least prevalent wind direction <sup>(c)</sup> .		
	<u>SECTOR</u>	<u>CODE</u>	<u>DISTANCE from station (miles)</u>
	WSW (control)	CL-116	14
b. Fish and Inverte- brates	1 sample each of 3 important species (such as bass, crappie, carp, or bluegill) in vicinity of plant discharge area.	Sample in season, or semiannually if they are not seasonal	Gamma isotopic analysis <sup>a</sup> on edible portions.
	<u>SECTOR</u>	<u>CODE</u>	<u>DISTANCE from station (miles)</u>
	E	CL-19	3.4
	1 sample of same species in areas not influenced by plant discharge.		
	<u>SECTOR</u>	<u>CODE</u>	<u>DISTANCE from station (miles)</u>
	S (control)	CL-105	50

TABLE 5.1-1 (Continued)

RADIOLOGICAL ENVIRONMENTAL MONITORING PROGRAM

<u>EXPOSURE PATHWAY AND/OR SAMPLE</u>	<u>NUMBER OF REPRESENTATIVE SAMPLES AND SAMPLE LOCATIONS<sup>a</sup></u>	<u>SAMPLING AND COLLECTION FREQUENCY</u>	<u>TYPE AND FREQUENCY OF ANALYSIS</u>
4. INGESTION (continued)			
c. Food Products	1 sample of each principal class of food products from any area that is irrigated by water in which liquid plant wastes have been discharged.*	At time of harvest <sup>j</sup>	Gamma isotopic analysis <sup>e</sup> on edible portion.
	*No known usage of Salt Creek water for irrigation in DeWitt, Logan, Menard, or Cass Counties. This information is checked annually as part of the land use survey.		
	Samples of 3 different kinds of broad leaf vegetation (such as lettuce, cabbage, and swiss chard) grown nearest each of two different offsite locations of highest predicted annual average ground-level D/Q if milk sampling is not performed.	Monthly during growing season	Gamma isotopic <sup>e</sup> and I-131 analysis.
	<u>SECTOR</u>	<u>CODE</u>	<u>DISTANCE from station (miles)</u>
	NE	CL-115	0.7
	N	CL-117	0.9
	NNE	CL-118	0.7

TABLE 5.1-1 (Continued)

RADIOLOGICAL ENVIRONMENTAL MONITORING PROGRAM

<u>EXPOSURE PATHWAY AND/OR SAMPLE</u>	<u>NUMBER OF REPRESENTATIVE SAMPLES AND SAMPLE LOCATIONS<sup>a</sup></u>	<u>SAMPLING AND COLLECTION FREQUENCY</u>	<u>TYPE AND FREQUENCY OF ANALYSIS</u>
4. INGESTION (continued)			
c. Food Products (continued)	1 sample of each of the similar broad leaf vegetation grown 15-30 km (9.3 miles to 18.6 miles) distant in the least prevalent wind direction <sup>(c)</sup> if milk sampling is not performed.	Monthly during growing season	Gamma isotopic <sup>e</sup> and I-131
	<u>SECTOR</u>	<u>CODE</u>	<u>DISTANCE from station (miles)</u>
	SSE (Control)	CL-114	12.5

TABLE 5.1-1 (Continued)RADIOLOGICAL ENVIRONMENTAL MONITORING PROGRAMTABLE NOTATIONS

<sup>a</sup>Refer to NUREG-0133, "Preparation of Radiological Effluent Technical Specifications for Nuclear Power Plants," October 1978, and to Radiological Assessment Branch Technical Position, Revision 1, November 1979. Deviations are permitted from the required sampling schedule if specimens are unobtainable due to hazardous conditions, seasonal unavailability, malfunction of automatic sampling equipment and other legitimate reasons. If specimens are unobtainable due to sampling equipment malfunction, every effort shall be made to complete corrective action prior to the end of the next sampling period. All deviations from the sampling schedule shall be documented in the Annual Radioactive Release Report pursuant to Technical Specification 5.6.3. It is recognized that, at times, it may not be possible or practicable to continue to obtain samples of the media of choice at the most desired location or time. In these instances suitable alternative media and locations may be chosen for the particular pathway in question and appropriate substitutions made within 30 days in the radiological environmental monitoring program given in the ODCM. Pursuant to Technical Specification 5.5.1, identify the cause of the unavailability of samples for that pathway and identify the new location(s) for obtaining replacement samples in the next annual Radiological Environmental Operating Report and also include in the report a revised figure(s) and table for the ODCM reflecting the new location(s).

<sup>b</sup>One or more instruments, such as a pressurized ion chamber, for measuring and recording dose rate continuously may be used in place of, or in addition to, integrating dosimeters. For the purposes of this table, a thermoluminescent dosimeter (TLD) is considered to be one phosphor; two or more phosphors in a packet are considered as two or more dosimeters. Film badges shall not be used as dosimeters for measuring direct radiation. The 40 stations is not an absolute number. The number of direct radiation monitoring stations may be reduced according to geographical limitations; e.g., at an ocean site, some sectors will be over water so that the number of dosimeters may be reduced accordingly. The frequency of analysis or readout for TLD systems will depend upon the characteristics of the specific system used and should be selected to obtain optimum dose information with minimal fading.

TABLE 5.1-1 (Continued)RADIOLOGICAL ENVIRONMENTAL MONITORING PROGRAMTABLE NOTATIONS (Continued)

<sup>c</sup>The purpose of this sample is to obtain background information. If it is not practical to establish control locations in accordance with the distance and wind direction criteria, other sites that provide valid background data may be substituted.

<sup>d</sup>Airborne particulate sample filters shall be analyzed for gross beta radioactivity 24 hours or more after sampling to allow for radon and thoron daughter decay. If gross beta activity in air particulate samples is greater than ten times the yearly mean of control samples, gamma isotopic analysis shall be performed on the individual samples.

<sup>e</sup>Gamma isotopic analysis means the identification and quantification of gamma-emitting radionuclides that may be attributable to the effluents from the facility.

<sup>f</sup>The "upstream sample" shall be taken at a distance beyond significant influence of the discharge. The "downstream" sample shall be taken in an area beyond but near the mixing zone. "Upstream" samples in an estuary must be taken far enough upstream to be beyond the plant influence.

<sup>g</sup>A composite sample is one in which the quantity (aliquot) of liquid sampled is proportional to the quantity of flowing liquid (or time) and in which the method of sampling employed results in a specimen that is representative of the liquid flow. In this program composite sample aliquots shall be collected at time intervals that are very short (e.g., hourly) relative to the compositing period (e.g., monthly) in order to assure obtaining a representative sample.

<sup>h</sup>Groundwater samples shall be taken when this source is tapped for drinking or irrigation purposes in areas where the hydraulic gradient or recharge properties are suitable for contamination.

<sup>i</sup>The dose shall be calculated for the maximum organ and age group, using the methodology and parameters in Section 2.4.2.

TABLE 5.1-1 (Continued)

RADIOLOGICAL ENVIRONMENTAL MONITORING PROGRAM

TABLE NOTATIONS (Continued)

<sup>j</sup>If harvest occurs more than once a year, sampling shall be performed during each discrete harvest. If harvest occurs continuously, sampling shall be monthly. Attention shall be paid to including samples of tuberous and root food products.

<sup>k</sup>The dose shall be calculated for the maximum organ and age group, using the methodology and parameters in Section 3.5.4.



TABLE 5.1-2

## REPORTING LEVELS FOR RADIOACTIVITY CONCENTRATIONS IN ENVIRONMENTAL SAMPLES

<u>ANALYSIS</u>	<u>WATER</u> (pCi/l)	<u>AIRBORNE PARTICULATE</u> <u>OR GASES (pCi/m<sup>3</sup>)</u>	<u>FISH</u> (pCi/kg, wet)	<u>MILK</u> (pCi/l)	<u>FOOD PRODUCTS</u> (pCi/kg, wet)
H-3	20,000*				
Mn-54	1,000		30,000		
Fe-59	400		10,000		
Co-58	1,000		30,000		
Co-60	300		10,000		
Zn-65	300		20,000		
Zr-Nb-95	400***				
I-131	2**	0.9		3	100
Cs-134	30	10	1,000	60	1,000
Cs-137	50	20	2,000	70	2,000
Ba-La-140	200***			300	

\*For drinking water samples. This is 40CFR Part 141 value. If no drinking water pathway exists, a value of 30,000 pCi/l may be used.

\*\*If no drinking water pathway exists, a value of 20 pCi/l may be used.

\*\*\*Total for parent and daughter.

TABLE 5.1-3

DETECTION CAPABILITIES FOR ENVIRONMENTAL SAMPLE ANALYSIS<sup>a,b</sup>LOWER LIMIT OF DETECTION (LLD)<sup>c</sup>

<u>ANALYSIS</u>	<u>WATER</u> <u>(pCi/l)</u>	<u>AIRBORNE PARTICULATE</u> <u>OR GAS (pCi/m<sup>3</sup>)</u>	<u>FISH</u> <u>(pCi/kg, wet)</u>	<u>MILK</u> <u>(pCi/l)</u>	<u>FOOD PRODUCTS</u> <u>(pCi/kg, wet)</u>	<u>SEDIMENT</u> <u>(pCi/kg, dry)</u>
Gross beta	4	0.01				
H-3	2000*					
Mn-54	15		130			
Fe-59	30		260			
Co-58,60	15		130			
Zn-65	30		260			
Zr-95	30					
Nb-95	15					
I-131	1**	0.07		1	60	
Cs-134	15	0.05	130	15	60	150
Cs-137	18	0.06	150	18	80	180
Ba-140	60			60		
La-140	15			15		

\*If no drinking water pathway exists, a value of 3000 pCi/l may be used.

\*\*If no drinking water pathway exists, a value of 15 pCi/l may be used.

## TABLE 5.1-3 (Continued)

DETECTION FOR ENVIRONMENTAL SAMPLE ANALYSIS<sup>a, b</sup>TABLE NOTATIONS

<sup>a</sup>This list does not mean that only these nuclides are to be considered. Other peaks that are identifiable, together with those of the above nuclides, shall also be analyzed and reported in the Annual Radiological Environmental Operating Report pursuant to Technical Specification 5.6.2.

<sup>b</sup>Required detection capabilities for thermoluminescent dosimeters used for environmental measurements shall be in accordance with the recommendations of Regulatory Guide 4.13, Rev. 1, July 1977.

<sup>c</sup>The LLD is defined, for purposes of these specifications, as the smallest concentration of radioactive material in a sample that will yield a net count, above system background, that will be detected with 95% probability with only 5% probability of falsely concluding that a blank observation represents a "real" signal.

For a particular measurement system, which may include radiochemical separation:

$$LLD = 4.66s_b / [E \cdot V \cdot 2.22 \cdot Y \cdot \exp(-\lambda\Delta t)]$$

Where:

LLD is the "a priori" lower limit of detection as defined above, as picocuries per unit mass or volume,

$s_b$  is the standard deviation of the background counting rate or of the counting rate of a blank sample as appropriate, as counts per minute,

E is the counting efficiency, as counts per disintegration,

V is the sample size in units of mass or volume,

2.22 is the number of disintegrations per minute per picocurie,

Y is the fractional radiochemical yield, when applicable,

$\lambda$  is the radioactive decay constant for the particular radionuclide ( $\text{sec}^{-1}$ ), and

$\Delta t$  for environmental samples is the elapsed time between sample collection, or end of the sample collection period, and time of counting (sec).

Typical values of E, V, Y, and  $\Delta t$  should be used in the calculation.

CPS-ODCM.

It should be recognized that the LLD is defined as an a priori (before the fact) limit representing the capability of a measurement system and not as an a posteriori (after the fact) limit for a particular measurement. Analyses shall be performed in such a manner that the stated LLDs will be achieved under routine conditions. Occasionally background fluctuations, unavoidable small sample sizes, the presence of interfering nuclides, or other uncontrollable circumstances may render these LLDs unachievable. In such cases, the contributing factors shall be identified and described in the Annual Radiological Environmental Operating Report pursuant to Technical Specification 5.6.2.

5.2 Land Use Census - Operation and Surveillance RequirementsOPERATION REQUIREMENT

A land use census shall be conducted and shall identify within a distance of 8 km (5 miles) the location in each of the 16 meteorological sectors of the nearest milk animal, the nearest residence and the nearest garden\* of greater than 50 m<sup>2</sup> (500 ft<sup>2</sup>) producing broad leaf vegetation. For elevated or mixed-mode releases as defined in Regulatory Guide 1.111, Revision 1, July 1977, the land use census shall also identify within a distance of 5 km (3 miles) the location in each of the 16 meteorological sectors of all milk animals and all gardens of greater than 50 m<sup>2</sup> producing broad leaf vegetation. This requirement applies at all times.

REMEDIAL REQUIREMENT:

- a. With a land use census identifying a location(s) that yields a calculated dose or dose commitment greater than the values currently being calculated in Section 3.5.2.1, identify the new location(s) in the next Radioactive Effluent Release Report, pursuant to Technical Specification 5.6.3.
- b. With a land use census identifying a location(s) that yields a calculated dose or dose commitment (via the same exposure pathway) 20 percent greater than at a location from which samples are currently being obtained in accordance with Section 5.1, add the new location(s) to the radiological environmental monitoring program within 30 days. The sampling location(s), excluding the control station location, having the lowest calculated dose or dose commitment(s), via the same exposure pathway, may be deleted from this monitoring program after October 31 of the year in which this land use census was conducted. Pursuant to Technical Specification 5.5.1, identify the new location(s) in the next Radioactive Effluent Release Report and also include in the report a revised figure(s) and table for this manual reflecting the new location(s).

\*Broad leaf vegetation sampling of at least three different kinds of vegetation may be performed at the site boundary in each of two different direction sectors with the highest predicted D/Qs in lieu of the garden census. Specifications for broad leaf vegetation sampling in Table 5.1-1.4c shall be followed, including analysis of control samples.

SURVEILLANCE REQUIREMENTS

- 5.2.1 The land use census shall be conducted during the growing season at least once per 12 months using that information that will provide the best results, such as by a door-to-door survey, aerial survey, or by consulting local agriculture authorities. The results of the land use census shall be included in the annual Radiological Environmental Operating Report pursuant to Technical Specification 5.6.2.

5.3 Interlaboratory Comparison Program

All analyses for CPS Radiological Environmental Monitoring Program are performed by Teledyne Brown Engineering Environmental Services Midwest Laboratories (Teledyne) located in Northbrook, Illinois.

Teledyne has participated in interlaboratory comparison (cross-check) programs since the formulation of its quality control program in December 1971. These programs have been operated by agencies which supply environmental-type samples (e.g., milk or water) containing concentrations of radionuclides known to the issuing laboratory but not to the participant laboratories. The purpose of such a program is to provide an independent check on the laboratory's analytical procedures and to alert it to any possible problems.

Participant laboratories measure the concentrations of specified radionuclides and report them to the issuing laboratory. Several months later, the issuing laboratory reports the known values to the participant laboratories and specifies the range the results should fall within. Results consistently higher or lower than the known values and results outside the specific ranges indicate a need to check the instruments or procedures used.

If the results of a determination in the cross-check program are outside the control limits specified, CPS will require TIML to investigate the cause of the problem and take steps to correct it. The results of this investigation and corrective action shall be included in the Annual Radiological Environmental Operating Report.

Operation and Surveillance Requirements for the Interlaboratory Comparison Program are prescribed in Section 5.3.1 (which follows).

5.3.1 Interlaboratory Comparison Program - Operation and Surveillance Requirements

OPERATION REQUIREMENT

---

Analyses shall be performed on all radioactive materials, supplied as part of an Interlaboratory Comparison Program that corresponds to samples required by Table 5.1-1. This requirement applies at all times.

REMEDIAL REQUIREMENT:

- a. With analyses not being performed as required above, report the corrective actions taken to prevent a recurrence to the Commission in the Annual Radiological Environmental Operating Report pursuant to Technical Specification 5.6.2.

SURVEILLANCE REQUIREMENTS

---

- 5.3.1.1 The Interlaboratory Comparison Program is described in Section 5.3. A summary of the results obtained as part of the above required Interlaboratory Comparison Program shall be included in the Annual Radiological Environmental Operating Report pursuant to Technical Specification 5.6.2.

FIGURE 5.0-1

REMP LOCATIONS WITHIN 1 MILE OF CPS

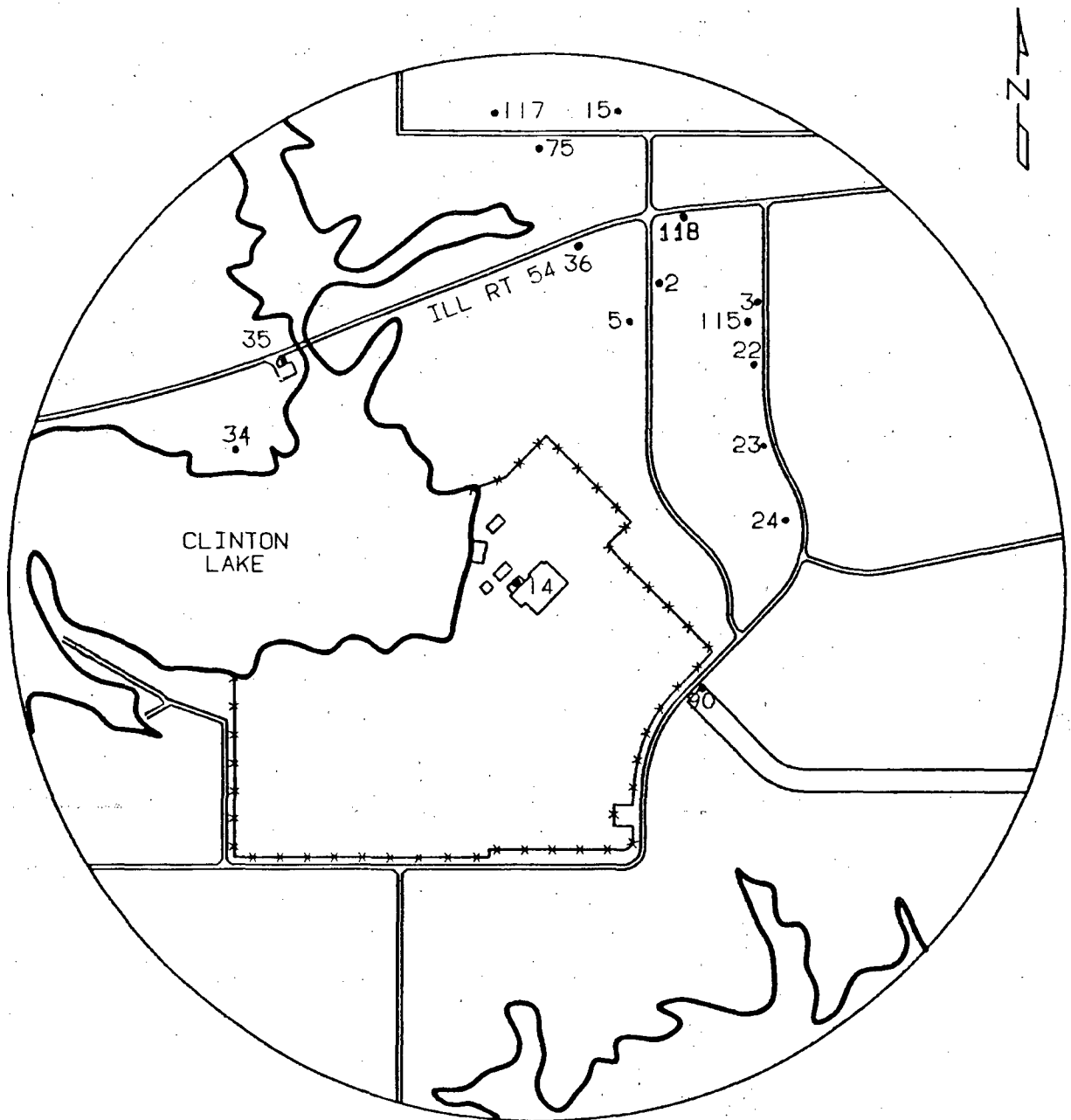



FIGURE 5.0-2

REMP LOCATIONS 1-2 MILES FROM CPS

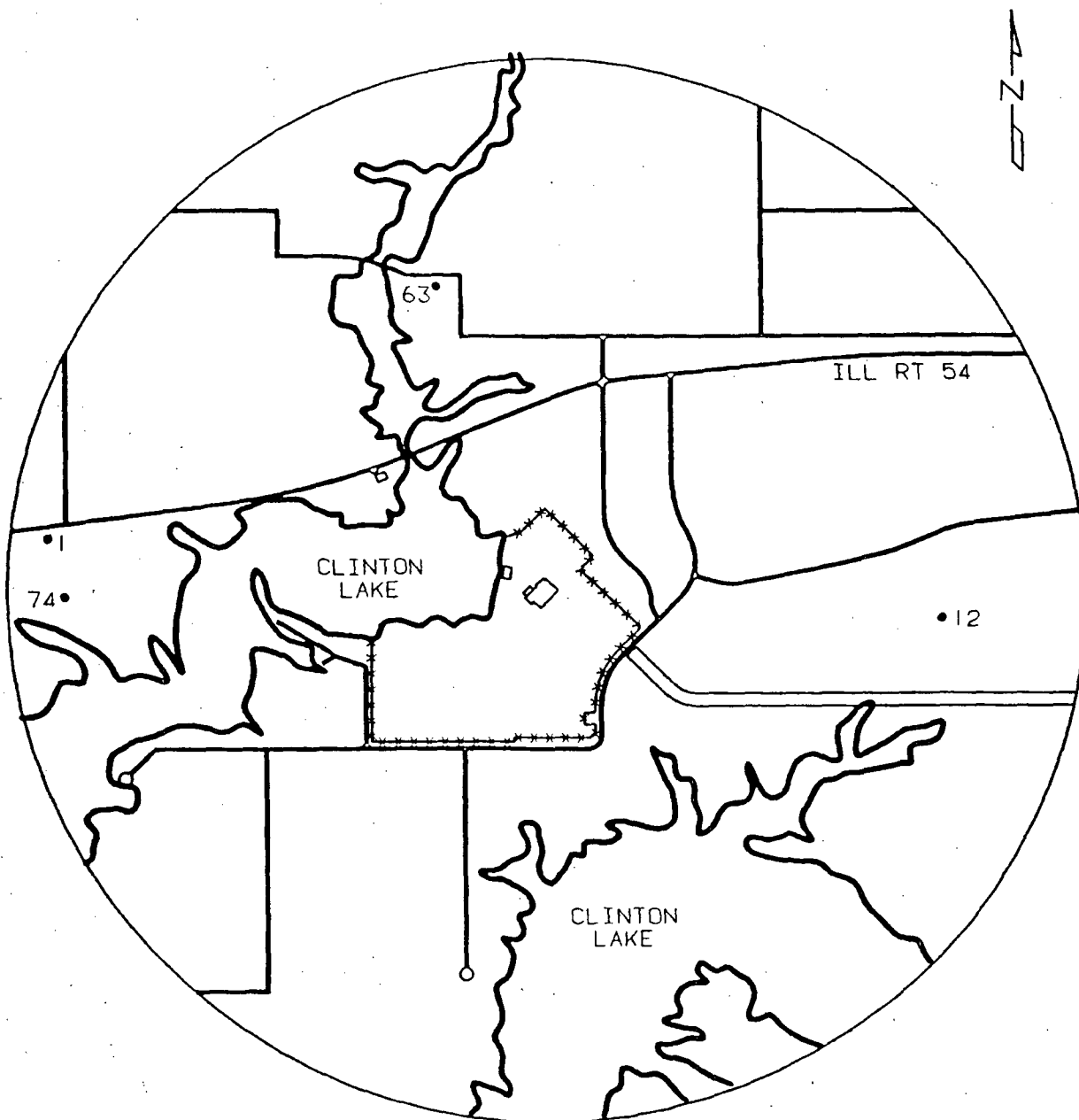

FIGURE 5.0-3  
REMP LOCATIONS 2-5 MILES FROM CPS

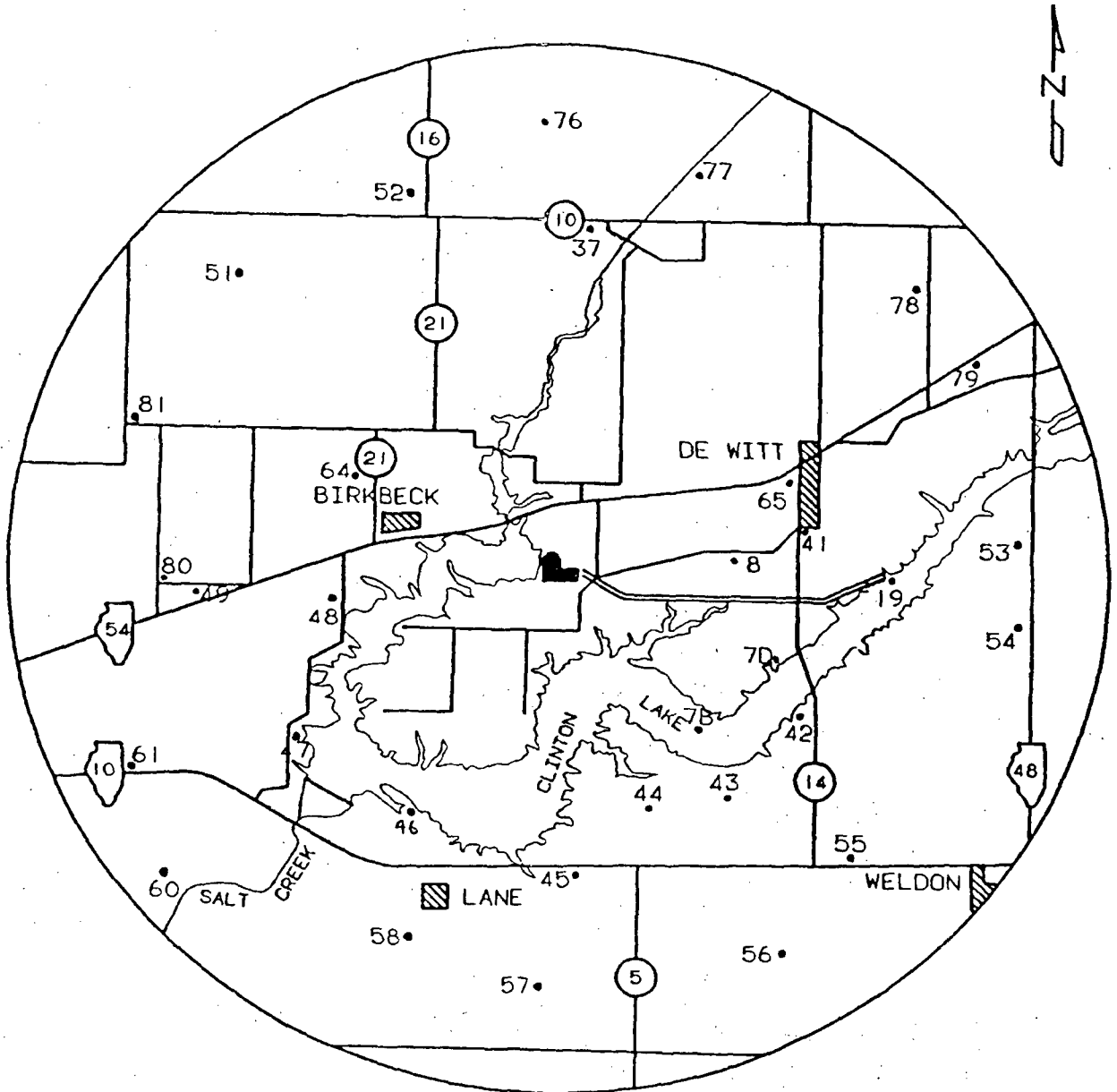
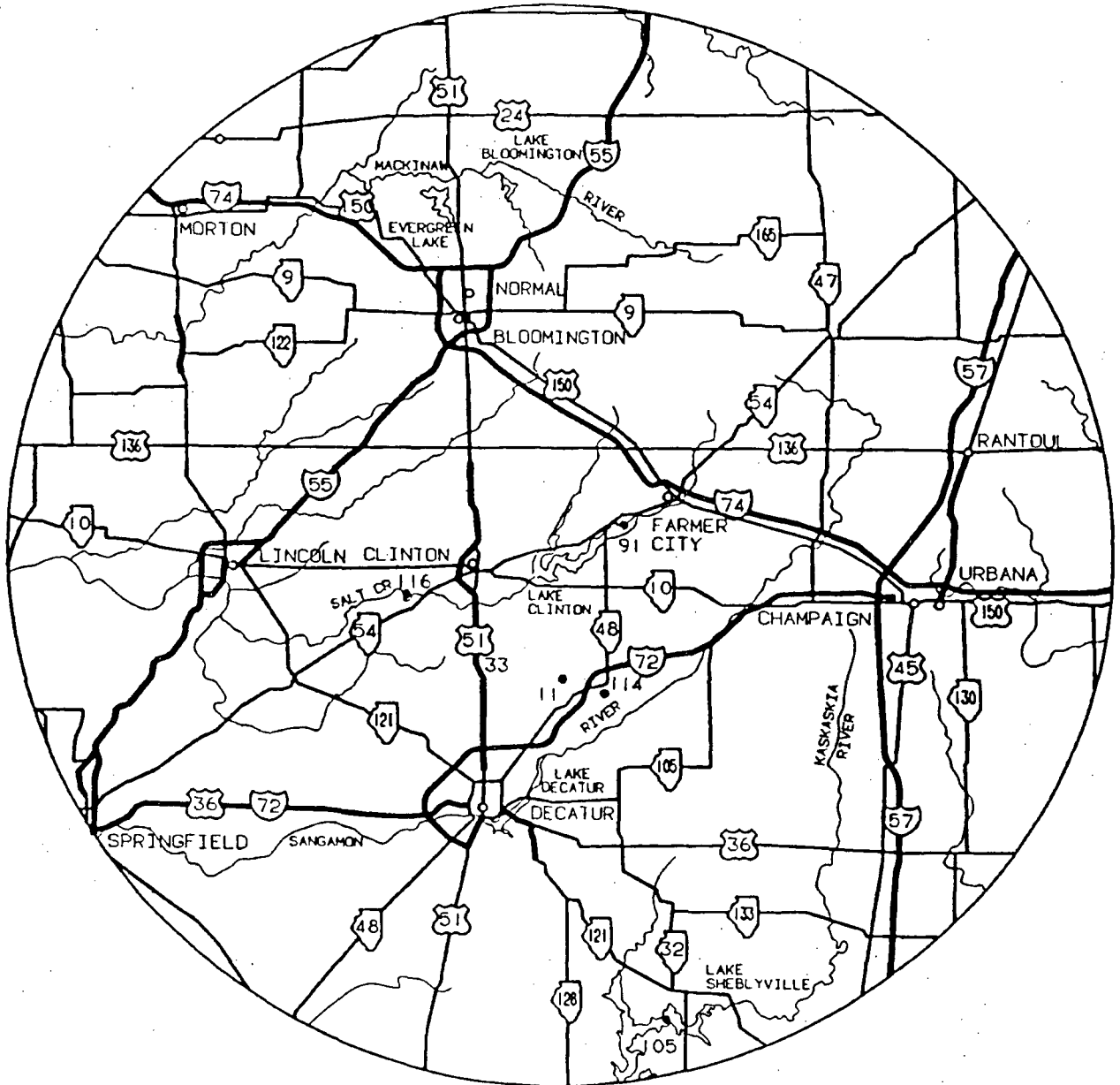

FIGURE 5.0-4

REMP LOCATIONS GREATER THAN 5 MILES FROM CPS



6.0 BASES FOR OPERATION AND SURVEILLANCE REQUIREMENTS

6.1 General Operation and Surveillance Requirements

The requirements of Sections 1.2 and 1.3 provide general requirements applicable to each of the Operation Requirements and Surveillance Requirements specified within Sections 2.0 through 5.0.

1.2.1 This requirement is provided to emphasize when each Operation Requirement is applicable and when the associated REMEDIAL REQUIREMENT should be met.

1.2.2 This requirement defines those conditions necessary to constitute compliance with the terms of an individual Operation Requirement and associated REMEDIAL REQUIREMENT.

1.3.1 This requirement provides that surveillance activities, necessary to ensure the Operation Requirements are met, will be performed during the conditions for which the Operation Requirements are applicable. Some surveillance activities may be required to be performed without regard to the applicable conditions specified in the associated Operation Requirement.

1.3.2 The provisions of this requirement provide allowable tolerances for performing surveillance activities beyond those specified in the nominal surveillance interval. These tolerances are necessary to provide operational flexibility because of scheduling and performance considerations. The phrase "at least" associated with a surveillance frequency does not negate this allowable tolerance; instead, it permits the more frequent performance of surveillance activities.

The tolerance values, taken either individually or consecutively over three test intervals, are sufficiently restrictive to ensure that the reliability associated with the surveillance activity is not significantly degraded beyond that obtained from the nominal specified interval.

1.3.3 The provisions of this requirement set forth the criteria for determination of compliance with the OPERABILITY requirements of the Operation Requirements. Under these criteria, equipment, systems, or components are assumed to be OPERABLE if the associated surveillance activities have been satisfactorily performed within the specified time interval. Nothing in this provision is to be construed as defining equipment, systems or components OPERABLE, when such items are found or known to be inoperable although still meeting the Surveillance Requirements.

## 6.2 Monitoring Instrumentation

### Section 2.7: Radioactive Liquid Effluent Monitoring Instrumentation

The radioactive liquid effluent instrumentation is provided to monitor and control, as applicable, the releases of radioactive materials in liquid effluents during actual or potential releases of liquid effluents. The alarm/trip setpoints for these instruments shall be calculated and adjusted in accordance with the methodology and parameters in this manual to ensure that the alarm/trip will occur prior to exceeding the limits of 10CFR Part 20. The OPERABILITY and use of this instrumentation is consistent with the requirements of General Design Criteria 60, 63 and 64 of Appendix A to 10CFR Part 50.

### Section 3.9.1: Offgas Radiation Monitoring Instrumentation

The OPERABILITY of the radiation monitoring instrumentation ensures that; (1) the radiation levels are continually measured in the areas served by the individual channels; (2) the alarm or automatic action is initiated when the radiation level trip setpoint is exceeded; and (3) sufficient information is available on selected plant parameters to monitor and assess these variables following an accident. This capability is consistent with 10CFR Part 50, Appendix A, General Design Criteria 19, 60, 61, 63 and 64.

### Section 3.9.2: Radioactive Gaseous Effluent Monitoring Instrumentation

The radioactive gaseous effluent instrumentation is provided to monitor and control, as applicable, the release of radioactive materials in gaseous effluents during actual or potential releases of gaseous effluents. The alarm/trip setpoints for these instruments shall be calculated and adjusted in accordance with the methodology and parameters in this manual to ensure that the alarm/trip will occur prior to exceeding the limits of 10CFR Part 20. The OPERABILITY and use of this instrumentation is consistent with the requirements of General Design Criteria 60, 63 and 64 of Appendix A to 10CFR Part 50. The sensitivity of any noble gas activity monitors used to show compliance with the gaseous effluent release requirements of Section 3.5.1 shall be such that concentrations as low as  $1 \times 10^{-6}$   $\mu\text{Ci/ml}$  are measurable.

## 6.3 Radioactive Effluents

### 6.3.1 Liquid Effluents

#### Section 2.3.1: Liquid Effluent Concentration

This requirement is provided to ensure that the concentration of radioactive materials released in liquid waste effluents to UNRESTRICTED AREAS will be less than ten times the concentration levels specified in 10CFR Part 20, Appendix B, Table 2, Column 2. This limitation provides additional assurance that the levels of radioactive materials in bodies of water in UNRESTRICTED AREAS will result in exposures within (1) the Section II.A design objectives of Appendix I, 10CFR Part 50, to a MEMBER OF THE PUBLIC and (2) the limits of 10CFR Part 20.1301 to the population. The concentration limit for dissolved or entrained noble gases is based upon the assumption that Xe-135 is the controlling radioisotope and its ECL in air (submersion) was converted to an equivalent concentration in water using the methods described in International Commission on Radiological Protection (ICRP) Publication 2.

This requirement applies to the release of radioactive materials in liquid effluents from the site.

The required detection capabilities for radioactive materials in liquid waste samples are tabulated in terms of the lower limits of detection (LLDs). Detailed discussion of the LLD, and other detection limits can be found in Currie, L. A., "Lower Limit of Detection: Definition and Elaboration of a Proposed Position for Radiological Effluent and Environmental Measurements," NUREG/CR-4007 (September 1984), and in the HASL Procedures Manual, HASL-300 (revised annually).

Section 2.4.1: 10CFR50, Appendix I Dose Limits

This requirement is provided to implement the requirements of Sections II.A, III.A and IV.A of Appendix I, 10CFR Part 50. The Limiting Condition for Operation implements the guides set forth in Section II.A of Appendix I. The ACTION statements provide the required operating flexibility and at the same time implement the guides set forth in Section IV.A of Appendix I to assure that the releases of radioactive material in liquid effluents to UNRESTRICTED AREAS will be kept "as low as is reasonably achievable." Also, for fresh water sites with drinking water supplies that can be potentially affected by plant operations, there is reasonable assurance that the operation of the facility will not result in radionuclide concentrations in the finished drinking water that are in excess of the requirements of 40CFR Part 141. The dose calculation methodology and parameters in this manual implement the requirements in Section III.A of Appendix I that conformance with the guides of Appendix I be shown by calculational procedures based on models and data, such that the actual exposure of a MEMBER OF THE PUBLIC through appropriate pathways is unlikely to be substantially underestimated. The equations specified in this manual for calculating the doses due to the actual release rates of radioactive materials in liquid effluents are consistent with the methodology provided in Regulatory Guide 1.109, "Calculation of Annual Doses to Man from Routine Releases of Reactor Effluents for the Purpose of Evaluating Compliance with 10CFR Part 50, Appendix I," Revision 1, October 1977 and Regulatory Guide 1.113, "Estimating Aquatic Dispersion of Effluents from Accidental and Routine Reactor Releases for the Purpose of Implementing Appendix I," April 1977.

This requirement applies to the release of radioactive materials in liquid effluents from the one reactor unit on the site.

Section 2.5.1: Liquid Radwaste Treatment System

The OPERABILITY of the liquid radwaste treatment system ensures that this system will be available for use whenever liquid effluents require treatment prior to release to the environment. The requirements that the appropriate portions of this system be used when specified, provides assurance that the releases of radioactive materials in liquid effluents will be kept "as low as is reasonably achievable." This specification implements the requirements of 10CFR Part 50.36a, General Design Criterion 60 of Appendix A to 10CFR Part 50 and the design objective given in Section II.D of appendix I to 10CFR Part 50. The specified limits governing the use of appropriate portions of the liquid radwaste treatment system were specified as a suitable fraction of the dose design objectives set forth in Section II.A of Appendix I, 10CFR Part 50, for liquid effluents.

This requirement applies to the release of radioactive materials in liquid effluents from the one reactor unit on the site.

6.3.2 Gaseous EffluentsSection 3.4.1: 10CFR20 Release Rate Limits

This requirement is provided to ensure that the dose at any time at and beyond the SITE BOUNDARY from gaseous effluents from all units on the site will be within the annual dose limits of 10CFR Part 20 to UNRESTRICTED AREAS. The annual dose limits are the doses associated with the concentrations of 10CFR Part 20, Appendix B, Table 2, Column 1. These limits provide reasonable assurance that radioactive material discharged in gaseous effluents will not result in the exposure of a MEMBER OF THE PUBLIC in an UNRESTRICTED AREA, either within or outside the SITE BOUNDARY, to annual average concentrations exceeding the limits specified in Appendix B, Table 2 of 10CFR Part 20. For MEMBERS OF THE PUBLIC who may at times be within the SITE BOUNDARY, the occupancy of that MEMBER OF THE PUBLIC will usually be sufficiently low to compensate for any increase in the atmospheric diffusion factor above that for the SITE BOUNDARY. Examples of such MEMBERS OF THE PUBLIC, with the appropriate occupancy factors, shall be given in this manual. Doses for such MEMBERS OF THE PUBLIC are provided in the Radioactive Effluent Release Report. The specified release rate limits restrict, at all times, the corresponding gamma and beta dose rates above background to a MEMBER OF THE PUBLIC, at or beyond the SITE BOUNDARY, to less than or equal to 500 mrem/year to the whole body or to less than or equal to 3000 mrem/year to the skin. These release rate limits also restrict, at all times, the corresponding thyroid dose rate above background to a child via the inhalation pathway to less than or equal to 1500 mrem/year.



This requirement applies to the release of radioactive materials in gaseous effluents from the one reactor unit on the site.

The required detection capabilities for radioactive materials in gaseous waste samples are tabulated in terms of the lower limits of detection (LLDs). Detailed discussion of the LLD, and other detection limits can be found in Currie, L. A., "Lower Limit of Detection: Definition and Elaboration of a Proposed Position for Radiological Effluent and Environmental Measurements," NUREG/CR-4007 (September 1984), and in the HASL Procedures Manual, HASL-300 (revised annually).

#### Section 3.5.1: Noble Gas Dose

This requirement is provided to implement the requirements of Sections II.B, III.A and IV.A of Appendix I, 10CFR Part 50. The Limiting Condition for Operation implements the guides set forth in Section II.B of Appendix I. The ACTION statements provide the required operating flexibility and at the same time implement the guides set forth in Section IV.A of Appendix I to assure that the releases of radioactive material in gaseous effluents to UNRESTRICTED AREAS will be kept "as low as is reasonably achievable." The Surveillance Requirements implement the requirements in Section III.A of Appendix I that conformance with the guides of Appendix I be shown by calculational procedures based on models and data such that the actual exposure of a MEMBER OF THE PUBLIC through appropriate pathways is unlikely to be substantially underestimated. The dose calculation methodology and parameters established in this manual for calculating the doses due to the actual release rates for radioactive noble gases in gaseous effluents are consistent with the methodology provided in Regulatory Guide 1.109, "Calculation of Annual Doses to Man from Routine Releases of Reactor Effluents for the Purpose of Evaluating Compliance with 10CFR Part 50, Appendix I," Revision 1, October 1977 and Regulatory Guide 1.111, "Methods for Estimating Atmospheric Transport and Dispersion of Gaseous Effluents in Routine Releases from Light-Water Cooled Reactors" Revision 1, July 1977.

This requirement applies to the release of radioactive materials in gaseous effluents from the site.

Section 3.5.2: Iodine-131, Iodine-133, Tritium, and Radionuclides in Particulate Form

This requirement is provided to implement the requirements of Sections II.C, III.A and IV.A of Appendix I, 10CFR Part 50. The Limiting Conditions for Operation are the guides set forth in Section II.C of Appendix I. The ACTION statements provide the required operating flexibility and at the same time implement the guides set forth in Section IV.A of Appendix I to assure that the releases of radioactive material in gaseous effluents to UNRESTRICTED AREAS will be kept "as low as is reasonably achievable." The calculational methods specified in the Surveillance Requirements implement the requirements in Section III.A of Appendix I that conformance with the guides of Appendix I be shown by calculational procedures based on models and data, such that the actual exposure of a MEMBER OF THE PUBLIC through appropriate pathways is unlikely to be substantially underestimated. The calculational methodology and parameters for calculating the doses due to the actual release rates of the subject materials are consistent with the methodology provided in Regulatory Guide 1.109, "Calculation of Annual Doses to Man from Routine Releases of Reactor Effluents for the Purpose of Evaluating Compliance with 10CFR Part 50, Appendix I," Revision 1, October 1977 and Regulatory Guide 1.111, "Methods for Estimating Atmospheric Transport and Dispersion of Gaseous Effluents in Routine Releases from Light-Water Cooled Reactors" Revision 1, July 1977. These equations also provide for determining the actual doses based upon the annual average atmospheric conditions. The release rate specifications for iodine-131, tritium, and radionuclides in particulate form with half lives greater than 8 days are dependent upon the existing radionuclide pathways to man in the areas at and beyond the SITE BOUNDARY. The pathways that were examined in the development of these calculations were: (1) individual inhalation of airborne radionuclides, (2) deposition of radionuclides onto green leafy vegetation with subsequent consumption by man, (3) deposition onto grassy areas where milk animals and meat producing animals graze with consumption of the milk and meat by man, and (4) deposition on the ground with subsequent exposure of man.

This requirement applies to the release of radioactive materials in gaseous effluents from one reactor unit on the site.

Sections 3.6 and 3.7: Gaseous Radwaste (Offgas) Treatment and Ventilation Exhaust Treatment System

The OPERABILITY of the WASTE GAS HOLDUP SYSTEM and the VENTILATION EXHAUST TREATMENT SYSTEM ensures that the systems will be available for use whenever gaseous effluents require treatment prior to release to the environment. The requirement that the appropriate portions of these systems be used, when specified, provides reasonable assurance that the releases of radioactive materials in gaseous effluents will be kept "as low as reasonably achievable." This requirement implements the requirements of 10CFR Part 50.36a, General Design Criterion 60 of Appendix A to 10CFR Part 50 and the design objectives given in Section II.D of Appendix I to 10CFR Part 50. The specified limits governing the use of appropriate portions of the systems were specified as a suitable fraction of the dose design objectives set forth in Section II.B and II.C of Appendix I, 10CFR Part 50, for gaseous effluents.

This requirement applies to the release of radioactive materials in gaseous effluents from the one reactor unit on the site.

6.3.3 Total DoseSection 4.1: Total Dose

This requirement is provided to meet the dose limitations of 40CFR Part 190 that have been incorporated into 10CFR20.1301. Dose monitoring requirements of 40CFR190 may be met through direct measurement (i.e., TLDs), determined from survey measurements, or calculated from shielding codes. CPS determines the 40CFR190 dose through calculation and by use of TLDs maintained and reported on as part of the Radiological Environmental Monitoring Program (REMP). The requirement requires the preparation and submittal of a Special Report whenever the calculated doses from plant generated radioactive effluents and direct radiation exceed 25 mrem to the total body or any organ, except the thyroid, which shall be limited to less than or equal to 75 mrem. For sites containing up to 4 reactors, it is highly unlikely that the resultant dose to a MEMBER OF THE PUBLIC will exceed the dose limits of 40CFR Part 190 if the individual reactors remain within twice the dose design objectives of Appendix I, and if direct radiation doses from the reactor units and outside storage tanks are kept small. The Special Report will describe a course of action that should result in the limitation of the annual dose to a MEMBER OF THE PUBLIC to within the 40CFR Part 190 limits. For the purposes of the Special Report, it may be assumed that the dose commitment to the MEMBER OF THE PUBLIC from other uranium fuel cycles sources is negligible, with the exception that dose contributions from other nuclear fuel cycle facilities at the same site or within a radius of 8 km must be considered. If the dose to any MEMBER OF THE PUBLIC is estimated to exceed the requirements of 40CFR Part 190, the Special Report with a request for a variance (provided the release conditions resulting in violation of 40CFR Part 190 have not already been corrected), in accordance with the provisions of 40CFR Part 190.11 and 10CFR Part 20.2203, is considered to be a timely request and fulfills the requirements of 40CFR Part 190 until NRC staff action is completed. The variance only relates to the limits of 40CFR Part 190, and does not apply in any way to the other requirements for dose limitation of 10CFR Part 20, as addressed in Sections 2.3 and 3.4. An individual is not considered a MEMBER OF THE PUBLIC during any period in which he/she is engaged in carrying out any operation that is part of the nuclear fuel cycle.

6.4 Radiological Environmental MonitoringSection 5.1: Monitoring Program

The radiological environmental monitoring program required by this requirement provides representative measurements of radiation and of radioactive materials in those exposure pathways and for those radionuclides that lead to the highest potential radiation exposures of MEMBERS OF THE PUBLIC resulting from the station operation. This monitoring program implements Section IV.B.2 of Appendix I to 10CFR Part 50 and thereby supplements the radiological effluent monitoring program by verifying that the measurable concentrations of radioactive materials and levels of radiation are not higher than expected on the basis of the effluent measurements and the modeling of the environmental exposure pathways. Guidance for this monitoring program is provided by the Radiological Assessment Branch Technical Position on Environmental Monitoring, Revision 1, November 1979. The initially specified monitoring program will be effective for at least the first three years of commercial operation. Following this period, program changes may be initiated based on operational experience.

The required detection capabilities for environmental sample analyses are tabulated in terms of the lower limits of detection (LLDs). The LLDs required by Table 5.1-3 are considered optimum for routine environmental measurements in industrial laboratories. It should be recognized that the LLD is defined as an a priori (before the fact) limit representing the capability of a measurement system and not as an a posteriori (after the fact) limit for a particular measurement.

Detailed discussion of the LLD, and other detection limits, can be found in Currie, L. A., "Lower Limit of Detection: Definition and Elaboration of a Proposed Position for Radiological Effluent and Environmental Measurements," NUREG/CR-4007 (September 1984), and in the HASL Procedures Manual, HASL-300 (revised annually).

Section 5.2: Land Use Census

This requirement is provided to ensure that changes in the use of areas at and beyond the SITE BOUNDARY are identified and that modifications to the radiological environmental monitoring program are made if required by the results of this census. The land use census shall be performed using the best information available (e.g., a door-to-door survey, from aerial surveys, questionnaire, or from consulting with local agricultural authorities). This census satisfies the requirements of Section IV.B.3 of Appendix I to 10CFR Part 50. Restricting the census to gardens of greater than 50 m<sup>2</sup> provides assurance that significant exposure pathways via leafy vegetables will be identified and monitored since a garden of this size is the minimum required to produce the quantity (26 kg/year) of leafy vegetables assumed in Regulatory Guide 1.109 for consumption by a child. To determine this minimum garden size, the following assumptions were made: (1) 20% of the garden was used for growing broad leaf vegetation (i.e., similar to lettuce and cabbage) and (2) a vegetation yield of 2 kg/m<sup>2</sup>.

Section 5.3.1: Interlaboratory Comparison Program

The requirement for participation in an Interlaboratory Comparison Program is provided to ensure that independent checks on the precision and accuracy of the measurements of radioactive material in environmental sample matrices are performed as part of the quality assurance program for environmental monitoring in order to demonstrate that the results are valid for the purposes of Section IV.B.2 of Appendix I to 10CFR Part 50.

7.0 REPORTING REQUIREMENTS

7.1 Annual Radiological Environmental Operating Report

Routine Radiological Environmental Operating Reports covering the operation of the unit during the previous calendar year shall be submitted prior to May 1 of each year pursuant to Technical Specification 5.6.2.

The Annual Radiological Environmental Operating Reports shall include the following information:

1. Summaries, interpretations, and an analysis of trends of the results of the radiological environmental surveillance activities for the report period, including a comparison with preoperational studies, with operational controls as appropriate, and with previous environmental surveillance reports, and an assessment of the observed impacts of the plant operation on the environment.
2. The results of land use censuses required by Section 5.2.
3. Results of analysis of all radiological environmental samples and of all environmental radiation measurements taken during the period pursuant to the locations specified in the Tables and Figures in this manual, as well as summarized and tabulated results of these analyses and measurements in the format of the table in the Radiological Assessment Branch Technical Position, Revision 1, November 1979. In the event that some individual results are not available for inclusion with the report, the report shall be submitted noting and explaining the reasons for the missing results. The missing data shall be submitted as soon as possible in a supplementary report.
4. A summary description of the radiological environmental monitoring program.
5. At least two legible maps\* covering all sample locations keyed to a table giving distances and directions from the HVAC stack.

---

\*One map shall cover stations near the site boundary and a second map shall include the more distant stations.

6. The results of licensee participation in the Interlaboratory Comparison Program, required by Section 5.3.1.
7. Discussion of all deviations from the sampling schedule of Table 5.1-1.
8. Discussion of all analysis in which the LLD required by Table 5.1-3 was not achievable.

7.2 Radioactive Effluent Release Report

Routine Radioactive Effluent Release Reports covering the operation of the unit during the previous 12 months of operation shall be submitted by May 1 of each year pursuant to Technical Specification 5.6.3.

The Radioactive Effluent Release Report shall include the following information:

1. A summary of the quantities of radioactive liquid and gaseous effluents and solid waste released from the unit as outlined in Regulatory Guide 1.21, "Measuring, Evaluating, and Reporting Radioactivity in Solid Wastes and Releases of Radioactive Materials in Liquid and Gaseous Effluents from Light-Water-Cooled Nuclear Power Plants, Revision 1, June 1974, with data summarized on a quarterly basis following the format of Appendix B thereof. For solid wastes, the format for Table 3 in Appendix B shall be supplemented with 3 additional categories: class of solid wastes (as defined by 10CFR Part 61), type of container (e.g., LSA, Type A, Type B, Large Quantity), and SOLIDIFICATION agent or absorbent (e.g., cement, urea formaldehyde).
2. The following information for each class of solid waste (as defined by 10CFR Part 61) shipped offsite during the report period:
  - a. Total container volume,
  - b. Total curie quantity (specify whether determined by measurement or estimate),
  - c. Principal radionuclides (specify whether determined by measurement or estimate),
  - d. Source of waste and processing employed (e.g., dewatered spent resin, compacted dry waste, evaporator bottoms).



3. A list and description of unplanned releases from the site to UNRESTRICTED AREAS of radioactive materials in gaseous and liquid effluents made during the reporting period.
4. A listing of new locations for dose calculations and/or environmental monitoring identified by the land use census pursuant to Section 5.2.
5. Changes to the ODCM pursuant to Technical Specification 5.5.1.
6. Major changes to radioactive liquid, gaseous, and solid waste treatment systems. The discussion of each change shall contain:
  - a. A summary of the evaluation that led to the determination that the change could be made in accordance with 10CFR Part 50.59.
  - b. Sufficient detailed information to totally support the reason for the change without benefit of additional or supplemental information;
  - c. A detailed description of the equipment, components and processes involved and the interfaces with other plant systems;
  - d. An evaluation of the change, which shows the predicted releases of radioactive materials in liquid and gaseous effluents and/or quantity of solid waste that differ from those previously predicted in the license application and amendments thereto;
  - e. An evaluation of the change, which shows the expected minimum exposures to a MEMBER OF THE PUBLIC in the UNRESTRICTED AREA and to the general population that differ from those previously estimated in the license application and amendments thereto;
  - f. A comparison of the predicted releases of radioactive materials, in liquid and gaseous effluents and in solid waste, to the actual releases for the period prior to when the changes are to be made;
  - g. An estimate of the exposure to plant operating personnel as a result of the change; and
  - h. Documentation of the fact that the change was reviewed and found acceptable by the Plant Operations Review Committee (PORC).

\*Licensees may choose to submit the information called for in this requirement as part of its annual USAR update.

\*\*Changes described by this requirement shall become effective upon review by the PORC.

7. An annual summary of hourly meteorological data collected over the previous year. This annual summary may be either in the form of an hour-by-hour listing on magnetic tape of wind speed, wind direction, atmospheric stability, and precipitation (if measured); or in the form of joint frequency distributions of wind speed, wind direction, and atmospheric stability.

8. An assessment of the radiation doses due to the radioactive liquid and gaseous effluents released from the unit or station during the previous calendar year. Beta and gamma air dose due to the release of noble gas in gaseous effluents is calculated at the CPS site boundary in each of the 16 geographical directions surrounding CPS. Dose due to the release of radioactive iodines and particulates in gaseous effluents is calculated at the critical receptor location in each of the 16 geographical sectors surrounding CPS to a distance of 5 miles. Dose summaries based on these calculations are provided in the Radioactive Effluent Release Report.

9. An assessment of the radiation doses from radioactive liquid and gaseous effluents to MEMBERS OF THE PUBLIC due to their activities inside the SITE BOUNDARY (Figures 2.1-1 and 3.1-1) during the report period.

**Note:**

All assumptions used in making the following assessments, i.e., specific activity, exposure time and location, shall be included in these reports. Annual average meteorological conditions or meteorological conditions concurrent with the time of release of radioactive materials in gaseous effluents, as determined by sampling frequency and measurements, may be used for determining the gaseous pathway doses. The assessment of radiation doses shall be performed in accordance with the methodology and parameters in this manual.

10. An assessment of radiation doses to the likely most exposed MEMBER OF THE PUBLIC from reactor releases and other nearby uranium fuel cycle sources, including doses from primary effluent pathways and direct radiation, for the previous calendar year to show conformance with 40CFR Part 190, Environmental Radiation Protection Standards for Nuclear Power Operation.

Acceptable methods for calculating the dose contribution from liquid and gaseous effluents are given in Regulatory Guide 1.109, Rev. 1, October 1977.

8.0 ADJUSTMENT OF THE CPS ODCM METHODOLOGY

Consistent with the NRC Commissioners' opinion on 10CFR50 Appendix I dated April 30, 1975, CPS will use environmental monitoring data to improve dose calculational models and to request CPS ODCM changes on the basis of such operating experience data. Such adjustments are recognized as being especially important for the radioiodine-milk pathway where conservative regulatory guide assumptions have been made. By using environmental monitoring data, uncertainties associated with plume behavior, radioiodine chemical form, deposition and retention of forages, and milk consumption patterns may be circumvented or reduced.

9.0 ATMOSPHERIC TRANSPORT AND DISPERSION MODEL9.1 Introduction

The atmospheric transport and dispersion model used by AmerGen Energy Company LLC is a straight-line, sector-averaged Gaussian model designed to estimate average relative concentrations at various receptor points. The model was developed in accordance with routine release analysis procedures specified by Regulatory Guide 1.111 (Revision 1 July 1977), Section C.1.c "Constant Mean Wind Direction Models".

All meteorological and dose calculations prescribed in this manual are based on meteorological data concurrent with the time of release or the annual average values. Near-real time meteorological data processing is described in Section 9.2.

9.2 Concurrent Meteorological Data Processing

Meteorological data is acquired and processed through a model which utilizes bi-level hourly meteorological tower data or single level joint frequency data to perform the required analysis. Three distinct release modes are treated: elevated, ground and mixed. A set of four output arrays are generated for each dose receptor location as follows:

- ° Relative undecayed, undepleted plume concentration (X/Q)
- ° Relative decayed and depleted radioiodine and particulate concentration (D2DPXQ) [8 day decay]
- ° Relative decayed noble gas concentration (D1XQ) [2.26 day decay]
- ° Relative particulate and radioiodine deposition (D/Q)

Since the Regulatory Guide 1.111 depletion and deposition curves are defined only within the range encompassing 100 to 200,000 meters, analysis results are not considered valid outside this range. The following sections describe the calculations performed by the transport and dispersion model for a one hour time interval.

### 9.2.1 Determination of Pasquill Stability Class

The Pasquill Stability Class is determined by categorizing the temperature gradient,  $\Delta T$ , into one of several ranges between -0.900 and 0.900 °C/meter according to the following equation:

$$\Delta T = (T_U - T_L) / (H_U - H_L), \text{ °C/meter} \quad (1)$$

where

$T_U$  = Meteorological (met) tower upper level temperature, °C

$T_L$  = Meteorological tower lower level temperature, °C

$H_U$  = Meteorological tower upper level instrumentation height  
= 60 meters

$H_L$  = Meteorological tower level instrumentation height  
= 10 meters

$\Delta T$  is then classified according to the following scheme:

<u>Pasquill Stability</u>	<u>Defining Condition</u>
A (Extremely Unstable)	$-0.900 < \Delta T \leq -0.019$
B	$-0.019 < \Delta T \leq -0.017$
C	$-0.017 < \Delta T \leq -0.015$
D (Neutral)	$-0.015 < \Delta T \leq -0.005$
E	$-0.005 < \Delta T \leq 0.015$
F	$0.015 < \Delta T \leq 0.040$
G (Extremely Stable)	$0.040 < \Delta T \leq 0.900$
Invalid	$\Delta T \leq -0.900$ or $\Delta T > 0.900$

9.2.2 Calculation of Stack Height Wind Speed

The wind speed at the release point (HVAC Exhaust Stack or Standby Gas Treatment System Exhaust Stack) height, STACWS, is calculated using the expressions:

$$\text{STACWS} = \text{WSP}_U (\text{STACKH}/\text{H}_U)^P, \text{ meter/sec} \quad (2)$$

where

$\text{WSP}_U$  = Upper met tower level wind speed, meter/sec

$\text{WSP}_L$  = Lower met tower level wind speed, meter/sec

STACKH = Physical release point stack height

P = Wind power law exponent, 0.25 for stabilities A, B, C; 0.33 for stability D; 0.5 for stabilities E, F, G, dimensionless. These coefficients come from The Recommended Guide for the Prediction of the Dispersion of Airborne Effluents, May 1968.

All other parameters are as defined for equation (1).

9.2.3 Determination of Release Mode and the Entrainment Coefficient

The mode of release can be elevated, ground or mixed; the latter being a combination of the first two. The mode of release, as well as an entrainment coefficient, TCORR, are determined from the stack height, STACH, building height, BLDGHT, stack exit velocity, EXITV, and wind speed at the stack height, STACWS.

For effluents exhausted from release points that are higher than twice the height of adjacent solid structures,

$$\text{STACKH} > 2 (\text{BLDGHT}), \text{ TCORR} = 0.0 \quad (3)$$

the release is considered completely elevated and the entrainment coefficient is zero. For effluents released from points less than the height of adjacent solid structures, a ground-level release is assumed

$$\text{STACKH} < \text{BLDGHT}, \text{ TCORR} = 1.0 \quad (4)$$

and the entrainment coefficient is unity. For effluents released from points or vents at the level of, or above, adjacent solid structures, but lower than elevated release points,

$$2(\text{BLDGHT}) > \text{STACKH} > \text{BLDGHT} \quad (5)$$

the release is treated as elevated, ground or mixed according to the following relationships:

$$\text{ELEVATED: } \text{TCORR} = 0.00 \text{ if } \text{EXITV} > 5(\text{STACWS}) \quad (6)$$

$$\text{GROUND: } \text{TCORR} = 1.0 \text{ if } \text{EXITV} < \text{STACWS} \quad (7)$$

$$\text{MIXED: } \text{TCORR} = 0.30 - 0.06(\text{EXITV}/\text{STACWS}) \text{ if} \quad (8)$$

$$5(\text{STACWS}) \geq \text{EXITV} > 1.5(\text{STACWS})$$

$$\text{TCORR} = 2.58 - 1.58(\text{EXITV}/\text{STACWS}) \text{ if} \quad (9)$$

$$1.5(\text{STACWS}) \geq \text{EXITV} \geq (\text{STACWS})$$

In the mixed mode, the release is considered to occur as an elevated release 100 (1-TCORR) percent of the time and as a ground release 100 (TCORR) percent of the time. Each of these cases are then evaluated separately and the concentration X/Q calculated according to the fraction of the time each release occurs.

#### 9.2.4 Calculation of Vertical Standard Deviation

The vertical plume spread (vertical standard deviation),  $\sigma_z$  is a function of the distance from the release point to the reception point for a given Pasquill stability class. The numerical value of  $\sigma_z$  is obtained by linear interpolation of the values in the following table which are taken from Regulatory Guide 1.145:

TABLE 9.2-1

Distance (meters)	$\sigma_z$ Values Stability Class						
	A	B	C	D	E	F	G
200	31	21	15	10	6	4	3
500	120	55	34	19	13	8	5
1000	530	124	64	32	21	13	8
2000	1000	340	120	52	34	20	13
3000	1000	800	170	68	44	25	16
6000	1000	1000	300	110	71	35	23
10000	1000	1000	450	147	85	45	28
30000	1000	1000	1000	275	130	65	40
50000	1000	1000	1000	350	155	75	50
80000	1000	1000	1000	460	180	85	55

The values in this table are limited by the "mixing height lid" which is specified at 1000m.

9.2.5 Calculation of the Building Wake Correction

For ground-based and mixed-mode releases, an adjustment is made in the calculation of X/Q that takes into consideration initial mixing of the effluent plume within the building wake. This adjustment is an additional factor added in quadrature to the vertical plume spread equation (10):

$$\Sigma_z = [\sigma_z^2 + 0.5 (\text{BLDGHT})^2/\pi]^{1/2} \quad (10)$$

with the requirement that  $\Sigma_z$  is restricted to values

$$\Sigma_z \leq (3)^{1/2} (\sigma_z). \quad (11)$$

9.2.6 Calculation of Momentum Plume Rise

For elevated or mixed-mode releases only, the amount of plume rise due to the initial vertical momentum of the exhausted effluent,  $\Delta H$ , is calculated. For Pasquill stability classes A,B,C and D,  $\Delta H$  is calculated per section 9.2.6.1; for classes E,F and G, section 9.2.6.2 is used.

9.2.6.1  $\Delta H$  For Pasquill Class A,B,C and D

$\Delta H$  is calculated using both equations (12) and (13) and the minimum value is selected for use.

$$\Delta H_1 = 1.44 (\text{STACD}) (\text{EXITV}/\text{STACWS})^{2/3} (\text{X}/\text{STACD})^{1/3} \quad (12)$$

$$\Delta H_2 = 3.0 (\text{STACD}) (\text{EXITV}/\text{STACWS}), \text{ meter} \quad (13)$$

where

STACD = Internal release point stack diameter  
 = 3.77 meters (HVAC Exhaust Stack)  
 = 0.44 meters (SGTS Exhaust Stack)

EXITV = Stack exit velocity, meter/second  
 X = Distance to specified receptor, meter

All other parameters are as defined previously.



9.2.6.2  $\Delta H$  For Pasquill Class E, F and G

$\Delta H$  is determined by selecting the minimum value calculated by equations (12) and (13) above and equations (14) and (15) below:

$$\Delta H_3 = 4.0[(0.5(\text{EXITV})(\text{STACD}))^2/S]^{-1/3}, \text{ meter} \quad (14)$$

$$\Delta H_4 = 1.5[(0.5(\text{EXITV})(\text{STACD}))^2/\text{STACWS}]^{1/3}(S)^{-1/6}, \text{ meter} \quad (15)$$

where

S = Restoring acceleration per unit vertical displacement for adiabatic motion,  $\text{sec}^{-2}$

$$= 9.8 * T_z / (273 + T_{\text{amb}})$$

$T_z = 0.025$  (E stability - default value)

$T_z = 0.05$  (F stability - default value)

$T_z = 0.075$  (G stability - default value)

Where  $T_{\text{amb}}$  = Ambient air temperature ( $^{\circ}\text{C}$ ) [If temperature is missing, the default value will be used]

All other parameters are as defined in section 9.2.6.1.

9.2.7 Calculation of the Effective Plume Height

The effective plume height, H, is determined using section 9.2.6 results for the momentum plume rise,  $\Delta H$ , and the terrain height, TERAIN:

$$H = \text{STACKH} + \Delta H - \text{TERAIN}, \text{ meter} \quad (16)$$

where

TERAIN = Difference between the plant base height above mean sea level (MSL) and the receptor point height above MSL, meter  $\geq 0.0$ .

9.2.8 Determination of Affected Sectors

The wind direction for the hour determined which sector will be affected. Sectors are 22.5° arcs and are classified according to the following scheme:

TABLE 9.2-2  
WIND DIRECTION TABLE

Sector Number	Compass Direction	Wind Direction (WD)
1	N	0.0° < WD < 11.25° or 348.75° < WD < 360.00°
2	NNE	11.25° < WD < 33.75°
3	NE	33.75° < WD < 56.25°
4	ENE	56.25° < WD < 78.75°
5	E	78.75° < WD < 101.25°
6	ESE	101.25° < WD < 123.75°
7	SE	123.75° < WD < 146.25°
8	SSE	146.25° < WD < 168.75°
9	S	168.75° < WD < 191.25°
10	SSW	191.25° < WD < 213.75°
11	SW	213.75° < WD < 236.25°
12	WSW	236.25° < WD < 258.75°
13	W	258.75° < WD < 281.25°
14	WNW	281.25° < WD < 303.75°
15	NW	303.75° < WD < 326.25°
16	NNW	326.25° < WD < 348.75°

For elevated releases, the wind speed at the upper met tower level is used; ground releases use the speed of the wind at the lower met tower level. The wind direction is the same at both levels. During periods of calm wind, the wind speed is set at 0.5 meters/second the anemometer threshold value and assigned the direction measured for the hour.

9.2.9 Calculation of Depletion and Deposition Factors

The depletion, DPF, and deposition, DPSF, factors are taken from the tables below which have been derived from curves found in Regulatory Guide 1.111. Both the DPF and DPSF values depend on the effective plume height, H, the stability class, S, and the distance, X, to the receptor.

The Regulatory Guide 1.111 curves represent plumes that are 100, 60, 30, and 0 (ground-level) meters above the ground. For plume heights and receptor distances other than those listed, the factors are interpolated from the tables. The model assumes that, after full plume rise is achieved, the plume cannot get higher from the ground. The derivation of these curves assumed no change in terrain height with downwind distance. Since topography does change with distance, as does the vertical distance between the plume centerline and the ground, use more than one depletion or deposition value as the plume travels away from the plant with distance.

TABLE 9.2-3  
DPF - DEPLETION FACTORS  
FROM FIGURES 2 THROUGH 5 OF REGULATORY GUIDE 1.111

Height of Release (m)	Pasquill Stability Class	Distance (meters)									
		200	500	1,000	2,000	3,000	6,000	10,000	30,000	50,000	80,000
Ground	All	0.970	0.936	0.900	0.860	0.832	0.770	0.714	0.590	0.517	0.440
30	A,B,C	0.990	0.964	0.935	0.900	0.875	0.828	0.793	0.680	0.590	0.478
30	D	1.000	0.985	0.960	0.920	0.900	0.850	0.810	0.707	0.650	0.593
30	E,F,G	1.000	1.000	1.000	1.000	1.000	1.000	0.970	0.792	0.664	0.546
60	A,B,C	1.000	0.985	0.967	0.942	0.928	0.878	0.839	0.700	0.617	0.500
60	D	1.000	1.000	1.000	0.970	0.950	0.910	0.870	0.767	0.707	0.646
60	E,F,G	1.000	1.000	1.000	1.000	1.000	1.000	1.000	1.000	1.000	0.977
100	A,B,C	1.000	1.000	0.978	0.950	0.932	0.885	0.850	0.725	0.628	0.500
100	D	1.000	1.000	1.000	0.989	0.982	0.946	0.910	0.807	0.746	0.685
100	E,F,G	1.000	1.000	1.000	1.000	1.000	1.000	1.000	1.000	1.000	1.000

TABLE 9.2-4  
 DPSF - DEPOSITION FACTORS  
 FROM FIGURES 6 THROUGH 9 OF REGULATORY GUIDE 1.111 (m<sup>-1</sup>)\*

Height of Release (m)	Pasquill Stability Class	Distance (meters)									
		200	500	1,000	2,000	3,000	6,000	10,000	30,000	50,000	80,000
Ground	All	1.25E-04	8.00E-05	5.40E-05	3.20E-05	2.60E-05	1.50E-05	9.90E-06	4.50E-06	3.00E-06	2.00E-06
30	A,B,C	1.10E-04	8.00E-05	4.20E-05	2.40E-05	1.80E-05	1.10E-05	8.00E-06	4.80E-06	4.00E-06	3.50E-06
30	D	5.50E-06	4.10E-06	4.80E-05	3.00E-05	2.40E-05	1.30E-05	8.00E-06	3.40E-06	2.30E-06	1.60E-06
30	E,F,G	1.00E-11	1.00E-10	1.00E-09	1.00E-08	1.00E-07	2.00E-06	6.30E-06	8.80E-06	5.30E-06	3.00E-06
60	A,B,C	1.80E-05	4.40E-05	3.80E-05	2.40E-05	1.80E-05	1.10E-05	8.20E-06	5.00E-06	4.20E-06	3.50E-06
60	D	2.80E-07	5.50E-06	1.60E-05	2.00E-05	1.80E-05	1.30E-05	8.90E-06	3.60E-06	2.50E-06	1.70E-06
60	E,F,G	1.00E-14	1.00E-13	1.00E-12	1.00E-11	1.00E-10	1.00E-09	1.00E-08	1.60E-08	2.00E-07	6.80E-07
100	A,B,C	4.00E-06	2.60E-05	3.30E-05	2.40E-05	1.70E-05	1.10E-05	8.10E-06	5.00E-06	4.50E-06	3.70E-06
100	D	1.00E-08	2.60E-07	2.50E-06	9.00E-06	1.10E-05	1.00E-05	7.50E-06	3.90E-06	2.80E-06	1.90E-06
100	E,F,G	1.00E-15	1.00E-15	1.00E-18	1.00E-15	1.00E-15	1.00E-15	1.00E-15	1.00E-15	1.00E-15	1.00E-15

9.2.10 Ground Level X/Q, D2DPXQ, D1XQ, D/Q Analysis9.2.10.1 Undecayed, Undepleted Plume Relative Concentration, X/Q

The atmospheric concentration of effluent at ground level, normalized by the source term Q, is given by the following equation:

$$X/Q = 2.032(TCORR)/WSP_L(X)A_{min}, \text{ sec/m}^3 \quad (17)$$

where

$A_{min}$  = The lesser of the two values obtained by equations (10) and (11), meter

2.032 = The constant  $(2/\pi)^{\ll}$  divided by the width in radians of a  $22.5^\circ$  sector (i.e.,  $\pi/8$ , dimensionless

X = Distance between release point to receptor, meter

9.2.10.2 Decayed, Depleted Radioiodine and Particulate Relative Concentration, D2DPXQ

The decayed, depleted radioiodine concentration, D2DPXQ, is calculated in accordance with the following equation:

$$D2DPXQ = DPF(DC2)X/Q, \text{ sec/m}^3 \quad (18)$$

where

DPF = The depletion factor calculated per section 9.2.9, dimensionless

DC2 = The radioiodine 8 day decay factor, dimensionless

$$= \exp[-0.693(X)/t_{\ll}(WSP_L)]$$

$$= \exp[-0.693(X)/(8 \text{ day})(24 \text{ hr/day})(3600 \text{ sec/hr})(WSP_L)]$$

$$= \exp[-1.00E-06(X/WSP_L)]$$

9.2.10.3 Decayed Noble Gas Plume Relative Concentration, D1XQ

The decayed noble gas plume relative concentration, D1XQ, is calculated in accordance with the following equation:

$$D1XQ = DC1 (X/Q), \text{ sec/m}^3 \quad (19)$$

where

DC1 = The noble gas decay factor, dimensionless

$$= \exp [-0.693(X)/t_{\ll}(WSP_L)]$$

$$= \exp [-0.693(X)/(2.26 \text{ day})(24 \text{ hr/day}) \\ (3600 \text{ sec/hr})(WSP_L)]$$

$$= \exp [-3.55E-06 (X/WSP_L)]$$

9.2.10.4 Radioiodine and Particulate Relative Deposition, D/Q

The relative deposition for radioiodines and particulates, D/Q is calculated in accordance with the following equation:

$$D/Q = [DPSF(DC2)(TCORR)]/[(2\pi/16)X], \text{ m}^{-2} \quad (20)$$

where

DPSF = The deposition factor calculated per section  
9.2.9,  $\text{m}^{-1}$

9.2.11 Elevated X/Q, D2DPXQ, D1XQ, D/Q Analysis9.2.11.1 Undecayed, Undepleted Plume Relative Concentration, X/Q

The atmospheric concentration of effluent at elevated level, normalized by the source term Q, is given by the following equation:

$$X/Q = \frac{[2.032(1-TCORR) \exp\{-0.5(H/\sigma_z)^2\}]}{\text{sec/m}^3} / [STACWS(X) \sigma_z], \quad (21)$$

where all parameters are as previously defined.

9.2.11.2 Decayed, Depleted Radioiodine and Particulate Relative Concentration, D2DPXQ

The calculation of D2DPXQ for elevated releases follows section 9.2.10.2 methodology with the exception that the  $WSP_L$  value used in the calculation of DC2 in equation (21) is replaced by the STACWS value and the equation (24) X/Q is used.

$$D2DPXQ = DPF(DC2)X/Q, \text{ sec/m}^3 \quad (22)$$

where

DPF = The depletion factor calculated per section 9.2.9, dimensionless

DC2 = The radioiodine 8 day decay factor, dimensionless

$$= \exp[-0.693(X)/t_{\ll}(STACWS)]$$

$$= \exp[-0.693(X)/(8 \text{ day})(24 \text{ hr/day})(3600 \text{ sec/hr})(STACWS)]$$

$$= \exp[-1.00E-06(X/STACWS)]$$

9.2.11.3 Decayed Noble Gas Plume Relative Concentration, D1XQ

The calculation of D1XQ for elevated releases follows section 9.2.10.3 methodology by substituting the equation (24) X/Q value into equation (22) and STACWS for  $WSP_L$  in the calculation of DC1.

$$D1XQ = DC1(X/Q), \text{ sec/m}^3 \quad (23)$$

where

DC1 = The noble gas decay factor, dimensionless

$$= \exp[-0.693(X)/t_{\ll}(STACWS)]$$

$$= \exp[-0.693(X)/(2.26 \text{ day})(24 \text{ hr/day})(3600 \text{ sec/hr})(STACWS)]$$

$$= \exp[-3.55E-06(X/STACWS)]$$

9.2.11.4 Radioiodine and Particulate Relative Deposition, D/Q

The calculation of D/Q for elevated releases follows section 9.2.10.4 methodology by substituting (1-TCORR) for the TCORR term in equation (23) and STACWS for  $WSP_L$  in the calculation of DC2.

$$D/Q = [DPSF(1-TCORR)]/[(2\pi/16)X], \text{ m}^{-2} \quad (24)$$

where

DPSF = The deposition factor calculated per section 9.2.9,  $\text{m}^{-1}$

Table 9.2-5

GASEOUS EFFLUENT RELEASE POINT CHARACTERISTICS

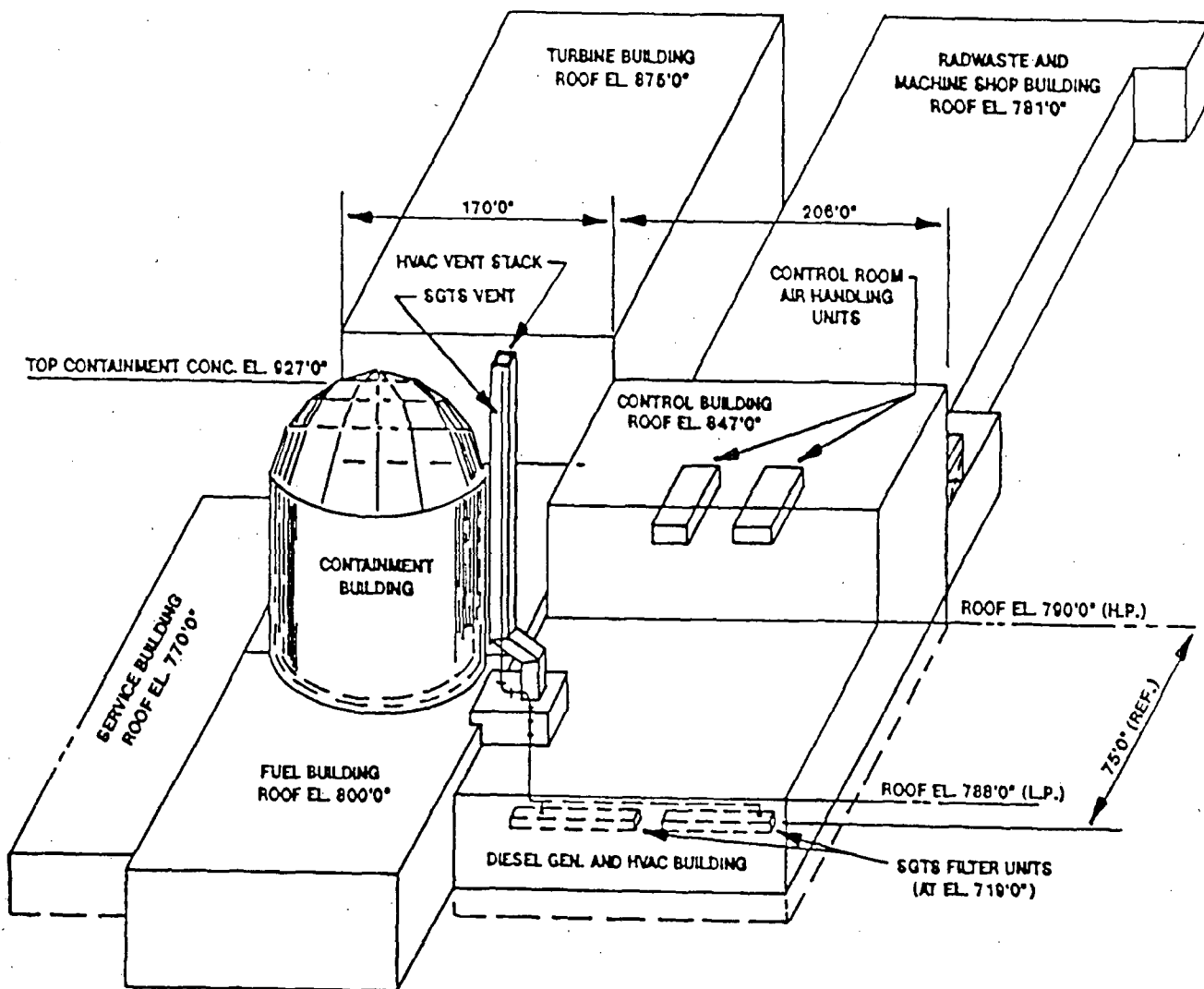

	<u>HVAC Exhaust Stack</u>	<u>SGTS Exhaust Stack</u>
Release Point Height (m)	61	61
Building Height (m)	58	58
Release Point Geometry	Duct	Pipe
Release Point Area (m <sup>2</sup> )	11.15	0.15
Release Point Diameter (m)	3.77*	0.44
Annual Average Flow Rate (m <sup>3</sup> /sec)	111.71	1.89
Vertical Exit Velocity (m/sec)	10.02	12.49

\*Effective  $2(A/\pi)$  diameter