

## CHAPTER 2<sup>†</sup>: PRINCIPAL DESIGN CRITERIA

This chapter contains a compilation of design criteria applicable to the HI-STORM 100 System. The loadings and conditions prescribed herein for the MPC, particularly those pertaining to mechanical accidents, are far more severe in most cases than those required for 10CFR72 compliance. The MPC is designed to be in compliance with both 10CFR72 and 10CFR71 and therefore certain design criteria are overly conservative for storage. This chapter sets forth the loading conditions and relevant acceptance criteria; it does not provide results of any analyses. The analyses and results carried out to demonstrate compliance with the design criteria are presented in the subsequent chapters of this report.

This chapter is in full compliance with NUREG-1536, except for the exceptions and clarifications provided in Table 1.0.3. Table 1.0.3 provides the NUREG-1536 review guidance, the justification for the exception or clarification, and the Holtec approach to meet the intent of the NUREG-1536 guidance.

### 2.0 PRINCIPAL DESIGN CRITERIA

The design criteria for the MPC, HI-STORM overpack, and HI-TRAC transfer cask are summarized in Tables 2.0.1, 2.0.2, and 2.0.3, respectively, and described in the sections that follow.

#### 2.0.1 MPC Design Criteria

##### General

The MPC is designed for 40 years of service, while satisfying the requirements of 10CFR72. The adequacy of the MPC design for the design life is discussed in Section 3.4.12.

##### Structural

The MPC is classified as important to safety. The MPC structural components include the internal fuel basket and the enclosure vessel. The fuel basket is designed and fabricated as a core support structure, in accordance with the applicable requirements of Section III, Subsection NG of the ASME Code, with certain NRC-approved alternatives, as discussed in Section 2.2.4. The enclosure vessel is designed and fabricated as a Class 1 component pressure vessel in accordance with Section III, Subsection NB of the ASME Code, with certain NRC-approved alternatives, as discussed in Section 2.2.4. The principal exception is the MPC lid, vent and drain port cover plates, and closure ring welds to the MPC lid and shell, as discussed in Section 2.2.4. In addition, the threaded holes in

---

† This chapter has been prepared in the format and section organization set forth in Regulatory Guide 3.61. However, the material content of this chapter also fulfills the requirements of NUREG-1536. Pagination and numbering of sections, figures, and tables are consistent with the convention set down in Chapter 1, Section 1.0, herein. Finally, all terms-of-art used in this chapter are consistent with the terminology of the glossary (Table 1.0.1) and component nomenclature of the Bill-of-Materials (Section 1.5).

the MPC lid are designed in accordance with the requirements of ANSI N14.6 for critical lifts to facilitate vertical MPC transfer.

The MPC closure welds are partial penetration welds that are structurally qualified by analysis, as presented in Chapter 3. The MPC lid and closure ring welds are inspected by performing a liquid penetrant examination of the root pass and/or final weld surface (if more than one weld pass was required), in accordance with the drawings contained in Section 1.5. The integrity of the MPC lid weld is further verified by performing a volumetric (or multi-layer liquid penetrant) examination, and a Code pressure test.

The structural analysis of the MPC, in conjunction with the redundant closures and nondestructive examination, pressure testing, and helium leak testing, (performed on the vent and drain port cover plates), provides assurance of canister closure integrity in lieu of the specific weld joint requirements of Section III, Subsection NB.

Compliance with the ASME Code as it is applied to the design and fabrication of the MPC and the associated justification are discussed in Section 2.2.4. The MPC is designed for all design basis normal, off-normal, and postulated accident conditions, as defined in Section 2.2. These design loadings include postulated drop accidents while in the cavity of the HI-STORM overpack or the HI-TRAC transfer cask. The load combinations for which the MPC is designed are defined in Section 2.2.7. The maximum allowable weight and dimensions of a fuel assembly to be stored in the MPC are limited in accordance with Section 2.1.5.

### Thermal

The design and operation of the HI-STORM 100 System meets the intent of the review guidance contained in ISG-11, Revision 3 [2.0.8]. Specifically, the ISG-11 provisions that are explicitly invoked and satisfied are:

- i. The thermal acceptance criteria for all commercial spent fuel (CSF) authorized by the USNRC for operation in a commercial reactor are unified into one set of requirements.
- ii. The maximum value of the *calculated* temperature for all CSF (including ZR and stainless steel fuel cladding materials) under long-term normal conditions of storage must remain below 400°C (752°F). For short-term operations, including canister drying, helium backfill, and on-site cask transport operations, the fuel cladding temperature must not exceed 400°C (752°F) for high burnup fuel and 570°C (1058°F) for moderate burnup fuel.
- iii. The maximum fuel cladding temperature as a result of an off-normal or accident event must not exceed 570°C (1058°F).
- iv. For High Burnup Fuel (HBF), operating restrictions are imposed to limit the maximum temperature excursion during short-term operations to 65°C (117°F).

To achieve compliance with the above criteria, certain design and operational changes are necessary, as summarized below.

- i. The peak fuel cladding temperature limit (PCT) for long term storage operations and short term operations is generally set at 400°C (752°F). However, for MPCs containing all moderate burnup fuel, the fuel cladding temperature limit for short-term operations is set at 570°C (1058°F) because fuel cladding stress is shown to be less than approximately 90 MPa per Reference [2.0.9]. Appropriate analyses have been performed as discussed in Chapter 4 and operating restrictions added to ensure these limits are met (see Section 4.5).
- ii. For MPCs containing at least one high burnup fuel (HBF) assembly, the forced helium dehydration (FHD) method of MPC cavity drying must be used to meet the normal operations PCT limit and satisfy the 65°C temperature excursion criterion for HBF.
- iii. The off-normal and accident condition PCT limit remains unchanged (1058°F).
- iv. For high burnup fuel, the Supplemental Cooling System (SCS) is required to ensure fuel cladding temperatures remain below the applicable temperature limit (see Section 4.5). The design criteria for the SCS are provided in Appendix 2.C.

The MPC cavity is dried using either a vacuum drying system, or a forced helium dehydration system (see Appendix 2.B). The MPC is backfilled with 99.995% pure helium in accordance with the limits in Table 1.2.2 during canister sealing operations to promote heat transfer and prevent cladding degradation.

The design temperatures for the structural steel components of the MPC are based on the temperature limits provided in ASME Section II, Part D, tables referenced in ASME Section III, Subsection NB and NG, for those load conditions under which material properties are relied on for a structural load combination. The specific design temperatures for the components of the MPC are provided in Table 2.2.3.

The MPCs are designed for a bounding thermal source term, as described in Section 2.1.6. The maximum allowable fuel assembly heat load for each MPC is limited as specified in Section 2.1.9.

Each MPC model, except MPC-68F, allows for two fuel loading strategies. The first is uniform fuel loading, wherein any authorized fuel assembly may be stored in any fuel storage location, subject to other restrictions, such as location requirements for damaged fuel containers (DFCs) and fuel with integral non-fuel hardware (e.g., control rod assemblies). The second is regionalized fuel loading, wherein the basket is segregated into two regions. Region 1 is the inner region where fuel assemblies with higher heat emission rates may be stored and Region 2 is the outer region where fuel assemblies with lower heat emission rates are stored. Regionalized loading allows for storage of fuel assemblies with higher heat emission rates (in Region 1) than would otherwise be authorized for loading under a uniform loading strategy. Regionalized loading strategies must also comply with other requirements, such as those for DFCs and non-

fuel hardware. Specific fuel assembly cooling time, burnup, and decay heat limits for regionalized loading are presented in Section 2.1.9. The two fuel loading regions are defined by fuel storage location number in Table 2.1.13 (refer to Figures 1.2.2 through 1.2.4). For MPC-68F, only uniform loading is permitted.

### Shielding

The allowable doses for an ISFSI using the HI-STORM 100 System are delineated in 10CFR72.104 and 72.106. Compliance with these regulations for any particular array of casks at an ISFSI is necessarily site-specific and is to be demonstrated by the licensee, as discussed in Chapters 5 and 12. Compliance with these regulations for a single cask and several representative cask arrays is demonstrated in Chapters 5 and 10.

The MPC provides axial shielding at the top and bottom ends to maintain occupational exposures ALARA during canister closure and handling operations. The occupational doses are controlled in accordance with plant-specific procedures and ALARA requirements (discussed in Chapter 10).

The MPCs are designed for design basis fuel as described in Sections 2.1.7 and 5.2. The radiological source term for the MPCs is limited based on the burnup and cooling times specified in Section 2.1.9. Calculated dose rates for each MPC are provided in Section 5.1. These dose rates are used to perform an occupational exposure evaluation, as discussed in Chapter 10.

### Criticality

The MPCs provide criticality control for all design basis normal, off-normal, and postulated accident conditions, as discussed in Section 6.1. The effective neutron multiplication factor is limited to  $k_{\text{eff}} < 0.95$  for fresh unirradiated fuel with optimum water moderation and close reflection, including all biases, uncertainties, and MPC manufacturing tolerances.

Criticality control is maintained by the geometric spacing of the fuel assemblies, fixed borated neutron absorbing materials incorporated into the fuel basket assembly, and, for certain MPC models, soluble boron in the MPC water. The minimum specified boron concentration verified during neutron absorber manufacture is further reduced by 25% for criticality analysis for Boral-equipped MPCs and by 10% for METAMIC<sup>®</sup>-equipped MPCs. No credit is taken for burnup. The maximum allowable initial enrichment for fuel assemblies to be stored in each MPC is limited. Enrichment limits and soluble boron concentration requirements are delineated in Section 2.1.9 consistent with the criticality analysis described in Chapter 6.

### Confinement

The MPC provides for confinement of all radioactive materials for all design basis normal, off-normal, and postulated accident conditions. As discussed in Section 7.1, the Holtec MPC design meets the guidance in Interim Staff Guidance 18 to classify confinement boundary leakage as non-

credible. Therefore, no confinement dose analysis is performed. The confinement function of the MPC is verified through pressure testing and helium leak testing on the vent and drain port cover plates and weld examinations performed in accordance with the acceptance test program in Chapter 9.

### Operations

There are no radioactive effluents that result from storage or transfer operations. Effluents generated during MPC loading are handled by the plant's radwaste system and procedures.

Generic operating procedures for the HI-STORM 100 System are provided in Chapter 8. Detailed operating procedures will be developed by the licensee based on Chapter 8, site-specific requirements that comply with the 10CFR50 Technical Specifications for the plant, and the HI-STORM 100 System CoC.

### Acceptance Tests and Maintenance

The fabrication acceptance basis and maintenance program to be applied to the MPCs are described in Chapter 9. The operational controls and limits to be applied to the MPCs are discussed in Chapter 12. Application of these requirements will assure that the MPC is fabricated, operated, and maintained in a manner that satisfies the design criteria defined in this chapter.

### Decommissioning

The MPCs are designed to be transportable in the HI-STAR overpack and are not required to be unloaded prior to shipment off-site. Decommissioning of the HI-STORM 100 System is addressed in Section 2.4.

## 2.0.2 HI-STORM Overpack Design Criteria

### General

The HI-STORM overpack is designed for 40 years of service, while satisfying the requirements of 10CFR72. The adequacy of the overpack design for the design life is discussed in Section 3.4.11.

### Structural

The HI-STORM overpack includes both concrete and structural steel components that are classified as important to safety.

The concrete material is defined as important to safety because of its importance to the shielding analysis. The primary function of the HI-STORM overpack concrete is shielding of the gamma and neutron radiation emitted by the spent nuclear fuel.

Unlike other concrete storage casks, the HI-STORM overpack concrete is enclosed in steel inner and

outer shells connected to each other by radial ribs, and top and bottom plates. Where typical concrete storage casks are reinforced by rebar, the HI-STORM overpack is supported by the inner and outer shells connected by radial ribs. As the HI-STORM overpack concrete is not reinforced, the structural analysis of the overpack only credits the compressive strength of the concrete. Providing further conservatism, the structural analyses for normal conditions demonstrate that the allowable stress limits of the structural steel are met even with no credit for the strength of the concrete. During accident conditions (e.g., tornado missile, tip-over, end drop, and earthquake), only the compressive strength of the concrete is accounted for in the analysis to provide an appropriate simulation of the accident condition. Where applicable, the compressive strength of the concrete is calculated in accordance with ACI-318-95 [2.0.1].

In recognition of the conservative assessment of the HI-STORM overpack concrete strength and the primary function of the concrete being shielding, the applicable requirements of ACI-349 [2.0.2] are invoked in the design and construction of the HI-STORM overpack concrete as clarified in Appendix 1.D.

Steel components of the storage overpack are designed and fabricated in accordance with the requirements of ASME Code, Section III, Subsection NF for Class 3 plate and shell components with certain NRC-approved alternatives.

The overpack is designed for all normal, off-normal, and design basis accident condition loadings, as defined in Section 2.2. At a minimum, the overpack must protect the MPC from deformation, provide continued adequate performance, and allow the retrieval of the MPC under all conditions. These design loadings include a postulated drop accident from the maximum allowable handling height, consistent with the analysis described in Section 3.4.10. The load combinations for which the overpack is designed are defined in Section 2.2.7. The physical characteristics of the MPCs for which the overpack is designed are defined in Chapter 1.

### Thermal

The allowable long-term through-thickness section average temperature limit for the overpack concrete is established in accordance with Paragraph A.4.3 of Appendix A to ACI 349, which allows the use of elevated temperature limits if test data supporting the compressive strength is available and an evaluation to show no concrete deterioration provided. Appendix 1.D specifies the cement and aggregate requirements to allow the utilization of the 300°F temperature limit. For short term conditions the through-thickness section average concrete temperature limit of 350°F is specified in accordance with Paragraph A.4.2 of Appendix A to ACI 349. The allowable temperatures for the structural steel components are based on the maximum temperature for which material properties and allowable stresses are provided in Section II of the ASME Code. The specific allowable temperatures for the structural steel components of the overpack are provided in Table 2.2.3.

The overpack is designed for extreme cold conditions, as discussed in Section 2.2.2.2. The structural steel materials used for the storage cask that are susceptible to brittle fracture are discussed in Section 3.1.2.3.

The overpack is designed for the maximum allowable heat load for steady-state normal conditions, in accordance with Section 2.1.6. The thermal characteristics of the MPCs for which the overpack is designed are defined in Chapter 4.

### Shielding

The off-site dose for normal operating conditions at the controlled area boundary is limited by 10CFR72.104(a) to a maximum of 25 mrem/year whole body, 75 mrem/year thyroid, and 25 mrem/year for other critical organs, including contributions from all nuclear fuel cycle operations. Since these limits are dependent on plant operations as well as site-specific conditions (e.g., the ISFSI design and proximity to the controlled area boundary, and the number and arrangement of loaded storage casks on the ISFSI pad), the determination and comparison of ISFSI doses to this limit are necessarily site-specific. Dose rates for a single cask and a range of typical ISFSIs using the HI-STORM 100 System are provided in Chapter 5. The determination of site-specific ISFSI dose rates at the site boundary and demonstration of compliance with regulatory limits is to be performed by the licensee in accordance with 10CFR72.212.

The overpack is designed to limit the calculated surface dose rates on the cask for all MPCs as defined in Section 2.3.5. The overpack is also designed to maintain occupational exposures ALARA during MPC transfer operations, in accordance with 10CFR20. The calculated overpack dose rates are determined in Section 5.1. These dose rates are used to perform a generic occupational exposure estimate for MPC transfer operations and a dose assessment for a typical ISFSI, as described in Chapter 10.

### Confinement

The overpack does not perform any confinement function. Confinement during storage is provided by the MPC and is addressed in Chapter 7. The overpack provides physical protection and biological shielding for the MPC confinement boundary during MPC dry storage operations.

### Operations

There are no radioactive effluents that result from MPC transfer or storage operations using the overpack. Effluents generated during MPC loading and closure operations are handled by the plant's radwaste system and procedures under the licensee's 10CFR50 license.

Generic operating procedures for the HI-STORM 100 System are provided in Chapter 8. The licensee is required to develop detailed operating procedures based on Chapter 8, site-specific conditions and requirements that also comply with the applicable 10CFR50 technical specification requirements for the site, and the HI-STORM 100 System CoC.

### Acceptance Tests and Maintenance

The fabrication acceptance basis and maintenance program to be applied to the overpack are described in Chapter 9. The operational controls and limits to be applied to the overpack are

contained in Chapter 12. Application of these requirements will assure that the overpack is fabricated, operated, and maintained in a manner that satisfies the design criteria defined in this chapter.

### Decommissioning

Decommissioning considerations for the HI-STORM 100 System, including the overpack, are addressed in Section 2.4.

#### 2.0.3 HI-TRAC Transfer Cask Design Criteria

##### General

The HI-TRAC transfer cask is designed for 40 years of service, while satisfying the requirements of 10CFR72. The adequacy of the HI-TRAC design for the design life is discussed in Section 3.4.11.

##### Structural

The HI-TRAC transfer cask includes both structural and non-structural biological shielding components that are classified as important to safety. The structural steel components of the HI-TRAC, with the exception of the lifting trunnions, are designed and fabricated in accordance with the applicable requirements of Section III, Subsection NF, of the ASME Code with certain NRC-approved alternatives, as discussed in Section 2.2.4. The lifting trunnions and associated attachments are designed in accordance with the requirements of NUREG-0612 and ANSI N14.6 for non-redundant lifting devices.

The HI-TRAC transfer cask is designed for all normal, off-normal, and design basis accident condition loadings, as defined in Section 2.2. At a minimum, the HI-TRAC transfer cask must protect the MPC from deformation, provide continued adequate performance, and allow the retrieval of the MPC under all conditions. These design loadings include a side drop from the maximum allowable handling height, consistent with the technical specifications. The load combinations for which the HI-TRAC is designed are defined in Section 2.2.7. The physical characteristics of each MPC for which the HI-TRAC is designed are defined in Chapter 1.

##### Thermal

The allowable temperatures for the HI-TRAC transfer cask structural steel components are based on the maximum temperature for material properties and allowable stress values provided in Section II of the ASME Code. The top lid of the HI-TRAC 125 and HI-TRAC 125D incorporate Holtite-A shielding material. This material has a maximum allowable temperature in accordance with the manufacturer's test data. The specific allowable temperatures for the structural steel and shielding components of the HI-TRAC are provided in Table 2.2.3. The HI-TRAC is designed for off-normal environmental cold conditions, as discussed in Section 2.2.2.2. The structural steel materials susceptible to brittle fracture are discussed in Section 3.1.2.3.



The HI-TRAC is designed for the maximum heat load analyzed for storage operations. When the MPC contains any high burnup fuel assemblies, the Supplemental Cooling System (SCS) will be required for certain time periods while the MPC is inside the HI-TRAC transfer cask (see Section 4.5). The design criteria for the SCS are provided in Appendix 2.C. The HI-TRAC water jacket maximum allowable temperature is a function of the internal pressure. To preclude over pressurization of the water jacket due to boiling of the neutron shield liquid (water), the maximum temperature of the water is limited to less than the saturation temperature at the shell design pressure. In addition, the water is precluded from freezing during off-normal cold conditions by limiting the minimum allowable temperature and adding ethylene glycol. The thermal characteristics of the fuel for each MPC for which the transfer cask is designed are defined in Section 2.1.6. The working area ambient temperature limit for loading operations is limited in accordance with the design criteria established for the transfer cask.

### Shielding

The HI-TRAC transfer cask provides shielding to maintain occupational exposures ALARA in accordance with 10CFR20, while also maintaining the maximum load on the plant's crane hook to below either 125 tons or 100 tons, or less, depending on whether the 125-ton or 100-ton HI-TRAC transfer cask is utilized. The HI-TRAC calculated dose rates are reported in Section 5.1. These dose rates are used to perform a generic occupational exposure estimate for MPC loading, closure, and transfer operations, as described in Chapter 10. A postulated HI-TRAC accident condition, which includes the loss of the liquid neutron shield (water), is also evaluated in Section 5.1.2. In addition,

HI-TRAC dose rates are controlled in accordance with plant-specific procedures and ALARA requirements (discussed in Chapter 10).

The HI-TRAC 125 and 125D provide better shielding than the HI-TRAC 100 or 100D. Provided the licensee is capable of utilizing the 125-ton HI-TRAC, ALARA considerations would normally dictate that the 125-ton HI-TRAC should be used. However, sites may not be capable of utilizing the 125-ton HI-TRAC due to crane capacity limitations, floor loading limits, or other site-specific considerations. As with other dose reduction-based plant activities, individual users who cannot accommodate the 125-ton HI-TRAC should perform a cost-benefit analysis of the actions (e.g., modifications), which would be necessary to use the 125-ton HI-TRAC. The cost of the action(s) would be weighed against the value of the projected reduction in radiation exposure and a decision made based on each plant's particular ALARA implementation philosophy.

The HI-TRAC provides a means to isolate the annular area between the MPC outer surface and the HI-TRAC inner surface to minimize the potential for surface contamination of the MPC by spent fuel pool water during wet loading operations. The HI-TRAC surfaces expected to require decontamination are coated. The maximum permissible surface contamination for the HI-TRAC is in accordance with plant-specific procedures and ALARA requirements (discussed in Chapter 10).

### Confinement

The HI-TRAC transfer cask does not perform any confinement function. Confinement during MPC

transfer operations is provided by the MPC, and is addressed in Chapter 7. The HI-TRAC provides physical protection and biological shielding for the MPC confinement boundary during MPC closure and transfer operations.

### Operations

There are no radioactive effluents that result from MPC transfer operations using HI-TRAC. Effluents generated during MPC loading and closure operations are handled by the plant's radwaste system and procedures.

Generic operating procedures for the HI-STORM 100 System are provided in Chapter 8. The licensee will develop detailed operating procedures based on Chapter 8, plant-specific requirements including the Part 50 Technical Specifications, and the HI-STORM 100 System CoC.

### Acceptance Tests and Maintenance

The fabrication acceptance basis and maintenance program to be applied to the HI-TRAC Transfer Cask are described in Chapter 9. The operational controls and limits to be applied to the HI-TRAC are contained in Chapter 12. Application of these requirements will assure that the HI-TRAC is fabricated, operated, and maintained in a manner that satisfies the design criteria defined in this chapter.

### Decommissioning

Decommissioning considerations for the HI-STORM 100 Systems, including the HI-TRAC Transfer Cask, are addressed in Section 2.4.

#### 2.0.4 Principal Design Criteria for the ISFSI Pad

##### 2.0.4.1 Design and Construction Criteria

In compliance with 10CFR72, Subpart F, "General Design Criteria", the HI-STORM 100 cask system is classified as "important-to-safety" (ITS). This final safety analysis report (FSAR) explicitly recognizes the HI-STORM 100 System as an assemblage of equipment containing numerous ITS components. The reinforced concrete pad on which the cask is situated, however, is designated as a non-ITS structure. This is principally because, in most cases, cask systems for storing spent nuclear fuel on reinforced concrete pads are installed as free-standing structures. The lack of a physical connection between the cask and the pad permits the latter to be designated as not important-to-safety.

However, if the ZPAs at the surface of an ISFSI pad exceed the threshold limit for free-standing HI-STORM installation set forth in this FSAR, then the cask must be installed in an anchored configuration (HI-STORM 100A).

In contrast to an ISFSI containing free-standing casks, a constrained-cask installation relies on the

structural capacity of the pad to ensure structural safety. The Part 72 regulations require consideration of natural phenomenon in the design. Since an ISFSI pad in an anchored cask installation participates in maintaining the stability of the cask during “natural phenomena” on the cask and pad, it is an ITS structure. The procedure suggested in Regulatory Guide 7.10 [2.0.4] and the associated NUREG [2.0.5] indicates that an ISFSI pad used to secure anchored casks should be classified as a Category C ITS structure.

Because tipover of a cask installed in an anchored configuration is not feasible, the pad does not need to be engineered to accommodate this non-mechanistic event. However, the permissible carry height for a loaded HI-STORM 100A overpack must be established for the specific ISFSI pad using the methodology described in this FSAR, if the load handling device is not designed in accordance with ANSI N 14.6 and does not have redundant drop protection design features. These requirements are specified in the CoC. However, to serve as an effective and reliable anchor, the pad must be made appropriately stiff and suitably secured to preclude pad uplift during a seismic event.

Because the geological conditions vary widely across the United States, it is not possible to, a priori, define the detailed design of the pad. Accordingly, in this FSAR, the limiting requirements on the design and installation of the pad are provided. The user of the HI-STORM 100A System bears the responsibility to ensure that all requirements on the pad set forth in this FSAR are fulfilled by the pad design. Specifically, the ISFSI owner must ensure that:

- The pad design complies with the structural provisions of this report. In particular, the requirements of ACI-349-97 [2.0.2] with respect to embedments must be assured.
- The material of construction of the pad (viz., the additives used in the pad concrete), and the attachment system are compatible with the ambient environment at the ISFSI site.
- The pad is designed and constructed in accordance with a Part 72, Subpart G-compliant QA program.
- The design and manufacturing of the cask attachment system are consistent with the provisions of this report.
- Evaluations are performed (e.g., per 72.212) to demonstrate that the seismic and other inertial loadings at the site are enveloped by the respective bounding loadings defined in this report.

A complete listing of design and construction requirements for an ISFSI pad on which an anchored HI-STORM 100A will be deployed is provided in Appendix 2.A. A sample embedment design is depicted in Figure 2.A.1.

#### 2.0.4.2 Applicable Codes

Factored load combinations for ISFSI pad design are provided in NUREG-1536 [2.1.5], which is

consistent with ACI-349-85. The factored loads applicable to the pad design consist of dead weight of the cask, thermal gradient loads, impact loads arising from handling and accident events, external missiles, and bounding environmental phenomena (such as earthquakes, wind, tornado, and flood). Codes ACI 360R-92, "Design of Slabs on Grade"; ACI 302.1R, "Guide for Concrete Floor and Slab Construction"; and ACI 224R-90, "Control of Cracking in Concrete Structures" should be used in the design and construction of the concrete pad, as applicable. The embedment design for the HI-STORM 100A (and 100SA) are the responsibility of the ISFSI owner and shall comply with Appendix B to ACI-349-97 as described in Appendix 2.A. A later Code edition may be used provided a written reconciliation is performed.

The factored load combinations presented in Table 3-1 of NUREG 1536 are reduced in the following to a bounding set of load combinations that are applied to demonstrate adherence to its acceptance criteria.

a. Definitions

- D = dead load including the loading due to pre-stress in the anchor studs
- L = live load
- W = wind load
- $W_t$  = tornado load
- T = thermal load
- F = hydrological load
- E = DBE seismic load
- A = accident load
- H = lateral soil pressure
- $T_a$  = accident thermal load
- $U_c$  = reinforced concrete available strength

Note that in the context of a complete ISFSI design, the DBE seismic load includes both the inertia load on the pad due to its self mass plus the interface loads transmitted to the pad to resist the inertia loads on the cask due to the loaded cask self mass. It is only these interface loads that are provided herein for possible use in the ISFSI structural analyses. The inertia load associated with the seismic excitation of the self mass of the slab needs to be considered in the ISFSI owner's assessment of overall ISFSI system stability in the presence of large uplift, overturning, and sliding forces at the base of the ISFSI pad. Such considerations are site specific and thus beyond the purview of this document.

b. Load Combinations for the Concrete Pad

The notation and acceptance criteria of NUREG-1536 apply.

Normal Events

$$U_c > 1.4D + 1.7L$$

$$U_c > 1.4D + 1.7(L+H)$$

### Off-Normal Events

$$U_c > 1.05D + 1.275 (L+H+T)$$
$$U_c > 1.05D + 1.275 (L+H+T+W)$$

### Accident-Level Events

$$U_c > D+L+H+T+F$$
$$U_c > D+L+H+T_a$$
$$U_c > D+L+H+T+E$$
$$U_c > D+L+H+T+W_t$$
$$U_c > D+L+H+T+A$$

In all of the above load combinations, the loaded cask weight is considered as a live load L on the pad. The structural analyses presented in Chapter 3 provide the interface loads contributing to "E", "F" and "W<sub>t</sub>", which, for high-seismic sites, are the most significant loadings. The above set of load combinations can be reduced to a more limited set by recognizing that the thermal loads acting on the ISFSI slab are small because of the low decay heat loads from the cask. In addition, standard construction practices for slabs serve to ensure that extreme fluctuations in environmental temperatures are accommodated without extraordinary design measures. Therefore, all thermal loads are eliminated in the above combinations. Likewise, lateral soil pressure load "H" will also be bounded by "F" (hydrological) and "E" (earthquake) loads. Accident loads "A", resulting from a tipover, have no significance for an anchored cask. The following three load combinations are therefore deemed sufficient for structural qualification of the ISFSI slab supporting an anchored cask system.

### Normal Events

$$U_c > 1.4D + 1.7 (L)$$

### Off-Normal Events

$$U_c > 1.05D + 1.275 (L+F)$$

### Accident-Level Events

$$U_c > D+L+E \text{ (or } W_t)$$

#### c. Load Combination for the Anchor Studs

The attachment bolts are considered to be governed by the ASME Code, Section III, Subsection NF and Appendix F [2.0.7]. Therefore, applicable load combinations and allowable stress limits for the attachment bolts are as follows:

Event Class and Load Combination	Governing ASME Code Section III Article for Stress Limits
Normal Events	

D	NF-3322.1, 3324.6
<u>Off-Normal Events</u>	
D+F	NF-3322.1, 3324.6 with all stress limits increased by 1.33
<u>Accident-Level Events</u>	
D+E and D+W <sub>t</sub>	Appendix F, Section F-1334, 1335

### 2.0.4.3 Limiting Design Parameters

Since the loaded HI-STORM overpack will be carried over the pad, the permissible lift height for the cask must be determined site-specifically to ensure the integrity of the storage system in the event of a handling accident (uncontrolled lowering of the load). To determine the acceptable lift height, it is necessary to set down the limiting ISFSI design parameters. The limiting design parameters for an anchored cask ISFSI pad and the anchor studs, as applicable, are tabulated in Table 2.0.4. The design of steel embedments in reinforced concrete structures is governed by Appendix B of ACI-349-97. Section B.5 in that appendix states that “anchorage design shall be controlled by the strength of embedment steel...”. Therefore, limits on the strength of embedment steel and on the anchor studs must be set down not only for the purposes of quantifying structural margins for the design basis load combinations, but also for the use of the ISFSI pad designer to establish the appropriate embedment anchorage in the ISFSI pad. The anchored cask pad design parameters presented in Table 2.0.4 allow for a much stiffer pad than the pad for free-standing HI-STORMs (Table 2.2.9). This increased stiffness has the effect of reducing the allowable lift height. However, a lift height for a loaded HI-STORM 100 cask (free-standing or anchored) is not required to be established if the cask is being lifted with a lift device designed in accordance with ANSI N14.6 having redundant drop protection design features.

In summary, the requirements for the ISFSI pad for free-standing and anchored HI-STORM deployment are similar with a few differences. Table 2.0.5 summarizes their commonality and differences in a succinct manner with the basis for the difference fully explained.

### 2.0.4.4 Anchored Cask/ISFSI Interface

The contact surface between the baseplate of overpack and the top surface of the ISFSI pad defines the structural interface between the HI-STORM overpack and the ISFSI pad. When HI-STORM is deployed in an anchored configuration, the structural interface also includes the surface where the nuts on the anchor studs bear upon the sector lugs on the overpack baseplate. The anchor studs and their fastening arrangements into the ISFSI pad are outside of the structural boundary of the storage cask. While the details of the ISFSI pad design for the anchored configuration, like that for the free-standing geometry, must be custom engineered for each site, certain design and acceptance criteria are specified herein (Appendix 2.A) to ensure that the design and construction of the pad fully comports with the structural requirements of the HI-STORM System.

Table 2.0.1  
MPC DESIGN CRITERIA SUMMARY

Type	Criteria	Basis	FSAR Reference
<b>Design Life:</b>			
Design	40 yrs.	-	Table 1.2.2
License	20 yrs.	10CFR72.42(a) and 10CFR72.236(g)	-
<b>Structural:</b>			
Design Codes:			
Enclosure Vessel	ASME Code, Section III, Subsection NB	10CFR72.24(c)(4)	Section 2.0.1
Fuel Basket	ASME Code, Section III, Subsection NG for core supports (NG-1121)	10CFR72.24(c)(4)	Section 2.0.1
MPC Fuel Basket Supports (Angled Plates)	ASME Code, Section III, Subsection NG for internal structures (NG-1122)	10CFR72.24(c)(4)	Section 2.0.1
MPC Lifting Points	ANSI N14.6/NUREG-0612	10CFR72.24(c)(4)	Section 1.2.1.4
Dead Weights <sup>†</sup> :			
Max. Loaded Canister (dry)	90,000 lb.	R.G. 3.61	Table 3.2.1
Empty Canister (dry)	42,000 lb. (MPC-24) 45,000 lb. (MPC-24E/EF) 39,000 lb. (MPC-68/68F/68FF) 36,000 lb. (MPC-32)	R.G. 3.61	Table 3.2.1
Design Cavity Pressures:			
Normal:	100 psig	ANSI/ANS 57.9	Section 2.2.1.3
Off-Normal:	110 psig	ANSI/ANS 57.9	Section 2.2.2.1
Accident (Internal)	200 psig	ANSI/ANS 57.9	Section 2.2.3.8
Accident (External)	60 psig	ANSI/ANS 57.9	Sections 2.2.3.6 and 2.2.3.10

<sup>†</sup> Weights listed in this table are bounding weights. Actual weights will be less, and will vary based on as-built dimensions of the components, fuel type, and the presence of fuel spacers and non-fuel hardware.

Table 2.0.1 (continued)  
MPC DESIGN CRITERIA SUMMARY

Type	Criteria	Basis	FSAR Reference
Response and Degradation Limits	SNF assemblies confined in dry, inert environment	10CFR72.122(h)(l)	Section 2.0.1
<b>Thermal:</b>			
Maximum Design Temperatures:			
Structural Materials:			
Stainless Steel (Normal)	725° F	ASME Code Section II, Part D	Table 2.2.3
Stainless Steel (Accident)	950° F	ASME Code Section II, Part D	Table 2.2.3
Neutron Poison:			
Neutron Absorber (normal)	800° F	See Table 4.3.1 and Section 1.2.1.3.1	Table 2.2.3
Neutron Absorber (accident)	950° F	See Table 4.3.1 and Section 1.2.1.3.1	Table 2.2.3
Canister Drying	$\leq 3$ torr for $\geq 30$ minutes (VDS)  $\leq 21^{\circ}\text{F}$ exiting the demoisturizer for $\geq 30$ minutes or a dew point of the MPC exit gas $\leq 22.9^{\circ}\text{F}$ for $\geq 30$ minutes(FHD)	NUREG-1536, ISG-11, Rev. 3	Section 4.5, Appendix 2.B
Canister Backfill Gas	Helium	-	Section 4.4
Canister Backfill	Varies (see Table 1.2.2)	Thermal Analysis	Section 4. 4
Fuel cladding temperature limit for long term storage conditions	752 °F (400 °C)	ISG-11, Rev. 3	Section 4.3
Fuel cladding temperature limit for normal short-term operating conditions (e.g., MPC drying and onsite transport)	752 °F (400 °C), except certain MPCs containing all moderate burnup fuel (MBF) may use 1058°F (570°C) for normal short-term operating conditions	ISG-11, Rev. 3	Sections 4.3 and 4.5



Table 2.0.1 (continued)  
MPC DESIGN CRITERIA SUMMARY

Type	Criteria	Basis	FSAR Reference
Fuel cladding temperature limit for Off-Normal and Accident Events	1058° F (570 °C)	ISG-11, Rev. 3	Sections 2.0.1 and 4.3
Insolation	Protected by overpack or HI-TRAC	-	Section 4.3
<b>Confinement:</b>		10CFR72.128(a)(3) and 10CFR72.236(d) and (e)	
Closure Welds:			
Shell Seams and Shell-to-Baseplate	Full Penetration	-	Section 1.5 and Table 9.1.4
MPC Lid	Multi-pass Partial Penetration	10CFR72.236(e)	Section 1.5 and Table 9.1.4
MPC Closure Ring	Partial Penetration		
Port Covers	Partial Penetration		
NDE:			
Shell Seams and Shell-to-Baseplate	100% RT or UT	-	Table 9.1.4
MPC Lid	Root Pass and Final Surface 100% PT; Volumetric Inspection or 100% Surface PT each 3/8" of weld depth	-	Chapter 8 and Table 9.1.4
Closure Ring	Root Pass (if more than one pass is required) and Final Surface 100% PT	-	Chapter 8 and Table 9.1.4
Port Covers	Root Pass (if more than one pass is required) and Final Surface 100% PT	-	Chapter 8 and Table 9.1.4
Leak Testing:			
Welds Tested	Port covers-to-MPC lid	-	Section 9.1
Medium	Helium	ANSI N14.5	Section 9.1
Max. Leak Rate	Leaktight	ANSI N14.5	Section 9.1
Monitoring System	None	10CFR72.128(a)(1)	Section 2.3.2.1

HOLTEC INTERNATIONAL COPYRIGHTED MATERIAL

Table 2.0.1 (continued)  
MPC DESIGN CRITERIA SUMMARY

Type	Criteria	Basis	FSAR Reference
<b>Pressure Testing:</b>			
Minimum Test Pressure	125 psig (hydrostatic) 120 psig (pneumatic)	-	Sections 8.1 and 9.1
Welds Tested	MPC Lid-to-Shell, MPC Shell seams, MPC Shell-to-Baseplate	-	Sections 8.1 and 9.1
Medium	Water or helium	-	Section 8.1 and Chapter 9
<b>Retrievability:</b>			
Normal and Off-normal: Post (design basis) Accident	No Encroachment on Fuel Assemblies	10CFR72.122(f) & (l)	Sections 3.4 and 3.1.2
<b>Criticality:</b>			
Method of Control	Fixed Borated Neutron Absorber, Geometry, and Soluble Boron	-	Section 2.3.4
Min. <sup>10</sup> B Loading (Boral/METAMIC®)	0.0267/0.0223 g/cm <sup>2</sup> (MPC-24) 0.0372/0.0310 g/cm <sup>2</sup> (MPC-68, MPC-68FF, MPC-24E, MPC-24EF, MPC-32 and MPC-32F) 0.01 g/cm <sup>2</sup> (MPC-68F)	-	Sections 2.1.8 and 6.1
Minimum Soluble Boron	Varies (see Tables 2.1.14 and 2.1.16)	Criticality Analysis	Sections 2.1.9 and 6.1
Max. k <sub>eff</sub>	0.95	-	Sections 6.1 and 2.3.4
Min. Burnup	0.0 GWd/MTU (fresh fuel)	-	Section 6.1
<b>Radiation Protection/Shielding:</b>			
MPC: (normal/off-normal/accident)		10CFR72.126, & 10CFR72.128(a)(2)	
MPC Closure	ALARA	10CFR20	Sections 10.1, 10.2, & 10.3
MPC Transfer	ALARA	10CFR20	Sections 10.1, 10.2, & 10.3
Exterior of Shielding: (normal/off-normal/accident)			

Table 2.0.1 (continued)  
MPC DESIGN CRITERIA SUMMARY

Type	Criteria	Basis	FSAR Reference
Transfer Mode Position	See Table 2.0.3	10CFR20	Section 5.1.1
ISFSI Controlled Area Boundary	See Table 2.0.2	10CFR72.104 & 10CFR72.106	Section 5.1.1 and Chapter 10
<b>Design Bases:</b>		10CFR72.236(a)	
Spent Fuel Specification:			
Assemblies/Canister	Up to 24 (MPC-24, MPC-24E & MPC-24EF) Up to 32 (MPC-32 and MPC-32F) Up to 68 (MPC-68, MPC-68F, & MPC-68FF)	-	Table 1.2.1 and Section 2.1.9
Type of Cladding	ZR and Stainless Steel	-	Section 2.1.9
Fuel Condition	Intact, Damaged, and Debris	-	Sections 2.1.2, 2.1.3, and 2.1.9
PWR Fuel Assemblies:			
Type/Configuration	Various	-	Section 2.1.9
Max. Burnup	68,200 MWD/MTU	-	Sections 2.1.9 and 6.2
Max. Enrichment	Varies by fuel design	-	Table 2.1.3 and Section 2.1.9
Max. Decay Heat/ MPC <sup>†</sup> :	28.74 kW	-	Section 4.4
Minimum Cooling Time:	3 years (Intact ZR Clad Fuel) 8 years (Intact SS Clad Fuel)	-	Section 2.1.9
Max. Fuel Assembly Weight: (including non-fuel hardware and DFC, as applicable)	1,680 lb.	-	Section 2.1.9
Max. Fuel Assembly Length: (Unirradiated Nominal)	176.8 in.	-	Section 2.1.9
Max. Fuel Assembly Width	8.54 in.	-	Section 2.1.9

<sup>†</sup> Section 2.1.9.1 describes the decay heat limits per assembly

Table 2.0.1 (continued)  
MPC DESIGN CRITERIA SUMMARY

Type	Criteria	Basis	FSAR Reference
(Unirradiated Nominal)			
BWR Fuel Assemblies:			
Type	Various	-	Sections 2.1.9 and 6.2
Max. Burnup	65,000 MWD/MTU	-	Section 2.1.9
Max. Enrichment	Varies by fuel design	-	Section 2.1.9, Table 2.1.4
Max. Decay Heat/ MPC <sup>†</sup>	28.19 kW	-	Section 4.4
Minimum Cooling Time:	3 years (Intact ZR Clad Fuel) 8 years (Intact SS Clad Fuel)		Section 2.1.9
Max. Fuel Assembly Weight:			
w/channels and DFC, as applicable	700 lb.	-	Section 2.1.9
Max. Fuel Assembly Length (Unirradiated Nominal)	176.5in.	-	Section 2.1.9
Max. Fuel Assembly Width (Unirradiated Nominal)	5.85 in.	-	Section 2.1.9
<b>Normal Design Event Conditions:</b>		10CFR72.122(b)(1)	
Ambient Temperatures	See Tables 2.0.2 and 2.0.3	ANSI/ANS 57.9	Section 2.2.1.4
Handling:			Section 2.2.1.2
Handling Loads	115% of Dead Weight	CMAA #70	Section 2.2.1.2
Lifting Attachment Acceptance Criteria	1/10 Ultimate 1/6 Yield	NUREG-0612 ANSI N14.6	Section 3.4.3
Attachment/Component Interface Acceptance Criteria	1/3 Yield	Regulatory Guide 3.61	Section 3.4.3
Away from Attachment Acceptance Criteria	ASME Code Level A	ASME Code	Section 3.4.3
Wet/Dry Loading	Wet or Dry	-	Section 1.2.2.2
Transfer Orientation	Vertical	-	Section 1.2.2.2
Storage Orientation	Vertical	-	Section 1.2.2.2

<sup>†</sup> Section 2.1.9.1 describes the decay heat limits per assembly.

Table 2.0.1 (continued)  
MPC DESIGN CRITERIA SUMMARY

Type	Criteria	Basis	FSAR Reference
Fuel Rod Rupture Releases:			
Source Term Release Fraction	1%	NUREG-1536	Sections 2.2.1.3
Fill Gases	100%	NUREG-1536	Sections 2.2.1.3
Fission Gases	30%	NUREG-1536	Sections 2.2.1.3
Snow and Ice	Protected by Overpack	ASCE 7-88	Section 2.2.1.6
<b>Off-Normal Design Event Conditions:</b>		10CFR72.122(b)(1)	
Ambient Temperature	See Tables 2.0.2 and 2.0.3	ANSI/ANS 57.9	Section 2.2.2.2
Leakage of One Seal	N/A	ISG-18	Sections 2.2.2.4 and 7.1
Partial Blockage of Overpack Air Inlets	Two Air Inlets Blocked	-	Section 2.2.2.5
Source Term Release Fraction:			
Fuel Rod Failures	10%	NUREG-1536	Sections 2.2.2.1
Fill Gases	100%	NUREG-1536	Sections 2.2.2.1
Fission Gases	30%	NUREG-1536	Sections 2.2.2.1
<b>Design-Basis (Postulated) Accident Design Events and Conditions:</b>		10CFR72.24(d)(2) & 10CFR72.94	
Tip Over	See Table 2.0.2	-	Section 2.2.3.2
End Drop	See Table 2.0.2	-	Section 2.2.3.1
Side Drop	See Table 2.0.3	-	Section 2.2.3.1
Fire	See Tables 2.0.2 and 2.0.3	10CFR72.122(e)	Section 2.2.3.3
Fuel Rod Rupture Releases:			
Fuel Rod Failures (including non-fuel hardware)	100%	NUREG-1536	Sections 2.2.3.8
Fill Gases	100%	NUREG-1536	Sections 2.2.3.8
Fission Gases	30%	NUREG-1536	Sections 2.2.3.8
Particulates & Volatiles	See Table 7.3.1	-	Sections 2.2.3.9
Confinement Boundary Leakage	None	ISG-18	Sections 2.2.3.9 and 7.1
Explosive Overpressure	60 psig (external)	10CFR72.122(c)	Section 2.2.3.10
Airflow Blockage:			

Table 2.0.1 (continued)  
MPC DESIGN CRITERIA SUMMARY

Type	Criteria	Basis	FSAR Reference
Vent Blockage	100% of Overpack Air Inlets Blocked	10CFR72.128(a)(4)	Section 2.2.3.13
Partial Blockage of MPC Basket Vent Holes	Crud Depth (Table 2.2.8)	ESEERCO Project EP91-29	Section 2.2.3.4
<b>Design Basis Natural Phenomenon Design Events and Conditions:</b>		10CFR72.92 & 10CFR72.122(b)(2)	
Flood Water Depth	125 ft.	ANSI/ANS 57.9	Section 2.2.3.6
Seismic	See Table 2.0.2	10CFR72.102(f)	Section 2.2.3.7
Wind	Protected by Overpack	ASCE-7-88	Section 2.2.3.5
Tornado & Missiles	Protected by Overpack	RG 1.76 & NUREG-0800	Section 2.2.3.5
Burial Under Debris	Maximum Decay Heat Load	-	Section 2.2.3.12
Lightning	See Table 2.0.2	NFPA 78	Section 2.2.3.11
Extreme Environmental Temperature	See Table 2.0.2	-	Section 2.2.3.14

Table 2.0.2  
HI-STORM OVERPACK DESIGN CRITERIA SUMMARY

Type	Criteria	Basis	FSAR Reference
<b>Design Life:</b>			
Design	40 yrs.	-	Section 2.0.2
License	20 yrs.	10CFR72.42(a) & 10CFR72.236(g)	
<b>Structural:</b>			
Design & Fabrication Codes:			
Concrete			
Design	ACI 349 as clarified in Appendix 1.D	10CFR72.24(c)(4)	Section 2.0.2 and Appendix 1.D
Fabrication	ACI 349 as clarified in Appendix 1.D	10CFR72.24(c)(4)	Section 2.0.2 and Appendix 1.D
Compressive Strength	ACI 318-95 as clarified in Appendix 1.D	10CFR72.24(c)(4)	Section 2.0.2 and Appendix 1.D
Structural Steel			
Design	ASME Code Section III, Subsection NF	10CFR72.24(c)(4)	Section 2.0.2
Fabrication	ASME Code Section III, Subsection NF	10CFR72.24(c)(4)	Section 2.0.2
Dead Weights <sup>†</sup> :			
Max. Loaded MPC (Dry)	90,000 lb. (MPC- 32)	R.G. 3.61	Table 3.2.1
Max. Empty Overpack Assembled with Top Lid (150 pcf concrete/200pcf concrete)	270,000/320,000 lb.	R.G. 3.61	Table 3.2.1
Max. MPC/Overpack (150 pcf concrete/200pcf concrete)	360,000/410,000 lb.	R.G. 3.61	Table 3.2.1
Design Cavity Pressures	N/A	-	Section 2.2.1.3

<sup>†</sup> Weights listed in this table are bounding weights. Actual weights will be less, and will vary based on as-built dimensions of the components, fuel type, and the presence of fuel spacers and non-fuel hardware, as applicable.

Table 2.0.2 (continued)  
 HI-STORM 100 OVERPACK DESIGN CRITERIA SUMMARY

Type	Criteria	Basis	FSAR Reference
Response and Degradation Limits	Protect MPC from deformation	10CFR72.122(b) 10CFR72.122(c)	Sections 2.0.2 and 3.1
	Continued adequate performance of overpack	10CFR72.122(b) 10CFR72.122(c)	
	Retrieval of MPC	10CFR72.122(l)	
<b>Thermal:</b>			
Maximum Design Temperatures:			
Concrete			
Through-Thickness Section Average (Normal)	300° F	ACI 349, Appendix A (Paragraph A.4.3)	Section 2.0.2, and Tables 1.D.1 and 2.2.3
Through-Thickness Section Average (Off-normal and Accident)	350° F	ACI 349 Appendix A (Paragraph A.4.2)	Section 2.0.2, and Tables 1.D.1 and 2.2.3
Steel Structure (other than lid bottom and top plates)	350° F	ASME Code Section II, Part D	Table 2.2.3
Lid Bottom and Top Plates	450° F		
Insolation:	Averaged Over 24 Hours	10CFR71.71	Section 4.4.1.1.8
<b>Confinement:</b>	None	10CFR72.128(a)(3) & 10CFR72.236(d) & (e)	N/A
<b>Retrievability:</b>			
Normal and Off-normal	No damage that precludes Retrieval of MPC	10CFR72.122(f) & (l)	Section 3.4
Accident			Section 3.4
<b>Criticality:</b>	Protection of MPC and Fuel Assemblies	10CFR72.124 & 10CFR72.236(c)	Section 6.1
<b>Radiation Protection/Shielding:</b>			
Overpack (Normal/Off-normal/Accident)		10CFR72.126 & 10CFR72.128(a)(2)	
Surface	ALARA	10CFR20	Chapters 5 and 10
Position	ALARA	10CFR20	Chapters 5 and 10



Table 2.0.2 (continued)  
 HI-STORM 100 OVERPACK DESIGN CRITERIA SUMMARY

Type	Criteria	Basis	FSAR Reference
Beyond Controlled Area During Normal Operation and Anticipated Occurrences	25 mrem/yr. to whole body 75 mrem/yr. to thyroid 25 mrem/yr. to any critical organ	10CFR72.104	Sections 5.1.1, 7.2, and 10.1
At Controlled Area Boundary from Design Basis Accident	5 rem TEDE or sum of DDE and CDE to any individual organ or tissue (other than lens of eye) $\leq$ 50 rem. 15 rem lens dose. 50 rem shallow dose to skin or extremity.	10CFR72.106	Sections 5.1.2, 7.3, and 10.1
<b>Design Bases:</b>			
Spent Fuel Specification	See Table 2.0.1	10CFR72.236(a)	Section 2.1.9
<b>Normal Design Event Conditions:</b>			
Ambient Outside Temperatures:			
Max. Yearly Average	80° F	ANSI/ANS 57.9	Section 2.2.1.4
Live Load <sup>†</sup> :		ANSI/ANS 57.9	-
Loaded Transfer Cask (max.)	250,000 lb. (HI-TRAC 125 w/transfer lid)	R.G. 3.61	Table 3.2.4 Section 2.2.1.2
Dry Loaded MPC (max.)	90,000 lb.	R.G. 3.61	Table 3.2.1 and Section 2.2.1.2
Handling:			
Handling Loads	115% of Dead Weight	CMAA #70	Section 2.2.1.2
Lifting Attachment Acceptance Criteria	1/10 Ultimate 1/6 Yield	NUREG-0612 ANSI N14.6	Section 3.4.3
Attachment/Component Interface Acceptance Criteria	1/3 Yield	Regulatory Guide 3.61	Section 3.4.3
Away from Attachment	ASME Code	ASME Code	Section 3.4.3

<sup>†</sup> Weights listed in this table are bounding weights. Actual weights will be less, and will vary based on as-built dimensions of the components, fuel type, and the presence of fuel spacers and non-fuel hardware, as applicable.

Table 2.0.2 (continued)  
 HI-STORM 100 OVERPACK DESIGN CRITERIA SUMMARY

Type	Criteria	Basis	FSAR Reference
Acceptance Criteria	Level A		
Minimum Temperature During Handling Operations	0° F	ANSI/ANS 57.9	Section 2.2.1.2
Snow and Ice Load	100 lb./ft <sup>2</sup>	ASCE 7-88	Section 2.2.1.6
Wet/Dry Loading	Dry	-	Section 1.2.2.2
Storage Orientation	Vertical	-	Section 1.2.2.2
<b>Off-Normal Design Event Conditions:</b>		10CFR72.122(b)(1)	
Ambient Temperature			
Minimum	-40° F	ANSI/ANS 57.9	Section 2.2.2.2
Maximum	100° F	ANSI/ANS 57.9	Section 2.2.2.2
Partial Blockage of Air Inlets	Two Air Inlet Ducts Blocked	-	Section 2.2.2.5
<b>Design-Basis (Postulated) Accident Design Events and Conditions:</b>		10CFR72.94	
Drop Cases:			
End	11 in.	-	Section 2.2.3.1
Tip-Over (Not applicable for HI-STORM 100A)	Assumed (Non-mechanistic)	-	Section 2.2.3.2
Fire:			
Duration	217 seconds	10CFR72.122(c)	Section 2.2.3.3
Temperature	1,475° F	10CFR72.122(c)	Section 2.2.3.3
Fuel Rod Rupture	See Table 2.0.1	-	Section 2.2.3.8
Air Flow Blockage:			
Vent Blockage	100% of Air Inlets Blocked	10CFR72.128(a)(4)	Section 2.2.3.13
Ambient Temperature	80° F	10CFR72.128(a)(4)	Section 2.2.3.13
Explosive Overpressure External Differential Pressure	10 psid instantaneous, 5 psid steady state	10 CFR 72.128(a)(4)	Table 2.2.1

Table 2.0.2 (continued)  
 HI-STORM 100 OVERPACK DESIGN CRITERIA SUMMARY

Type	Criteria	Basis	FSAR Reference
<b>Design-Basis Natural Phenomenon Design Events and Conditions:</b>		10CFR72.92 & 10CFR72.122(b)(2)	
Flood			
Height	125 ft.	RG 1.59	Section 2.2.3.6
Velocity	15 ft/sec.	RG 1.59	Section 2.2.3.6
Seismic			
Max. acceleration at top of ISFSI pad	Free Standing: $G_H + 0.53G_V \leq 0.53$ Anchored: $G_H \leq 2.12, G_V \leq 1.5$	10CFR72.102(f)	Section 3.4.7.1 Section 3.4.7.3
Tornado			
Wind			
Max. Wind Speed	360 mph	RG 1.76	Section 2.2.3.5
Pressure Drop	3.0 psi	RG 1.76	Section 2.2.3.5
Missiles			Section 2.2.3.5
Automobile			
Weight	1,800 kg	NUREG-0800	Table 2.2.5
Velocity	126 mph	NUREG-0800	Table 2.2.5
Rigid Solid Steel Cylinder			
Weight	125 kg	NUREG-0800	Table 2.2.5
Velocity	126 mph	NUREG-0800	Table 2.2.5
Diameter	8 in.	NUREG-0800	Table 2.2.5
Steel Sphere			
Weight	0.22 kg	NUREG-0800	Table 2.2.5
Velocity	126 mph	NUREG-0800	Table 2.2.5
Diameter	1 in.	NUREG-0800	Table 2.2.5
Burial Under Debris	Maximum Decay Heat Load	-	Section 2.2.3.12
Lightning	Resistance Heat-Up	NFPA 70 & 78	Section 2.2.3.11
Extreme Environmental Temperature	125° F	-	Section 2.2.3.14
<b>Load Combinations:</b>	See Table 2.2.14 and Table 3.1.5	ANSI/ANS 57.9 and	Section 2.2.7

Table 2.0.2 (continued)  
HI-STORM 100 OVERPACK DESIGN CRITERIA SUMMARY

<b>Type</b>	<b>Criteria</b>	<b>Basis</b>	<b>FSAR Reference</b>
		NUREG-1536	

TABLE 2.0.3  
HI-TRAC TRANSFER CASK DESIGN CRITERIA SUMMARY

Type	Criteria	Basis	FSAR Reference
<b>Design Life:</b>			
Design	40 yrs.	-	Section 2.0.3
License	20 yrs.	10CFR72.42(a) & 10CFR72.236(g)	
<b>Structural:</b>			
Design Codes:			
Structural Steel	ASME Code, Section III, Subsection NF	10CFR72.24(c)(4)	Section 2.0.3
Lifting Trunnions	NUREG-0612 & ANSI N14.6	10CFR72.24(c)(4)	Section 1.2.1.4
Dead Weights <sup>†</sup> :			
Max. Empty Cask:			
w/top lid and pool lid installed and water jacket filled	143,500 lb. (HI-TRAC 125) 102,000 lb. (HI-TRAC 100) 102,000 lb. (HI-TRAC 100D) 146,000 lb. (HI-TRAC 125D)	R.G. 3.61	Table 3.2.2
w/top lid and transfer lid installed and water jacket filled (N/A for HI-TRAC 100D and 125D)	155,000 lb. (HI-TRAC 125) 111,000 lb. (HI-TRAC 100)	R.G. 3.61	Table 3.2.2
Max. MPC/HI-TRAC with Yoke (in-pool lift):			
	250,000 lb. (HI-TRAC 125 and 125D) 200,000 lb. (HI-TRAC 100 and 100D)	R.G. 3.61	Table 3.2.4
Design Cavity Pressures:			
HI-TRAC Cavity	Hydrostatic	ANSI/ANS 57.9	Section 2.2.1.3
Water Jacket Cavity	60 psig (internal)	ANSI/ANS 57.9	Section 2.2.1.3

<sup>†</sup> Weights listed in this table are bounding weights. Actual weights will be less, and will vary based on as-built dimensions of the components, fuel type, and the presence of fuel spacers and non-fuel hardware, as applicable.

TABLE 2.0.3 (continued)  
HI-TRAC TRANSFER CASK DESIGN CRITERIA SUMMARY

Type	Criteria	Basis	FSAR Reference
Response and Degradation Limits	Protect MPC from deformation	10CFR72.122(b) 10CFR72.122(c)	Section 2.0.3
	Continued adequate performance of HI-TRAC transfer cask	10CFR72.122(b) 10CFR72.122(c)	
	Retrieval of MPC	10CFR72.122(l)	
<b>Thermal:</b>			
Maximum Design Temperature			
Structural Materials	400° F	ASME Code Section II, Part D	Table 2.2.3
Shielding Materials			
Lead	350° F (max.)		Table 2.2.3
Liquid Neutron Shield	307° F (max.)	-	Table 2.2.3
Solid Neutron Shield	300° F (max.) (long term) 350° F (max.) (short term)	Test Data	Appendix 1.B and Table 2.2.3
Insolation:	Averaged Over 24 Hours	10CFR71.71	Section 4.5.1.1.3
<b>Confinement:</b>	None	10CFR72.128(a)(3) & 10CFR72.236(d) & (e)	N/A
<b>Retrievability:</b>			
Normal and Off-normal	No encroachment on MPC	10CFR72.122(f) & (l)	Section 3.4
After Design-basis (Postulated) Accident			Section 3.4
<b>Criticality:</b>	Protection of MPC and Fuel Assemblies	10CFR72.124 & 10CFR72.236(c)	Section 6.1
<b>Radiation Protection/Shielding:</b>			
Transfer Cask (Normal/Off-normal/Accident)			
Surface	ALARA	10CFR20	Chapters 5 and 10
Position	ALARA	10CFR20	Chapters 5 and 10

TABLE 2.0.3 (continued)  
HI-TRAC TRANSFER CASK DESIGN CRITERIA SUMMARY

Type	Criteria	Basis	FSAR Reference
<b>Design Bases:</b>			
Spent Fuel Specification	See Table 2.0.1	10CFR72.236(a)	Section 2.1
<b>Normal Design Event Conditions:</b>			
Ambient Temperatures:			
Lifetime Average	100° F	ANSI/ANS 57.9	Section 2.2.1.4
Live Load <sup>†</sup>			
Max. Loaded Canister			
Dry	90,000 lb.	R.G. 3.61	Table 3.2.1
Wet (including water in HI-TRAC annulus)	106,570 lb.	R.G. 3.61	Table 3.2.4
<b>Handling:</b>			
Handling Loads	115% of Dead Weight	CMAA #70	Section 2.2.1.2
Lifting Attachment Acceptance Criteria	1/10 Ultimate 1/6 Yield	NUREG-0612 ANSI N14.6	Section 3.4.3
Attachment/Component Interface Acceptance Criteria	1/3 Yield	Regulatory Guide 3.61	Section 3.4.3
Away from Attachment Acceptance Criteria	ASME Code Level A	ASME Code	Section 3.4.3
Minimum Temperature for Handling Operations	0° F	ANSI/ANS 57.9	Section 2.2.1.2
Wet/Dry Loading	Wet or Dry	-	Section 1.2.2.2
Transfer Orientation	Vertical	-	Section 1.2.2.2
<b>Test Loads:</b>			
Trunnions	300% of vertical design load	NUREG-0612 & ANSI N14.6	Section 9.1.2.1
<b>Off-Normal Design Event Conditions:</b>			
Ambient Temperature			
Minimum	0° F	ANSI/ANS 57.9	Section 2.2.2.2
Maximum	100° F	ANSI/ANS 57.9	Section 2.2.2.2

<sup>†</sup> Weights listed in this table are bounding weights. Actual weights will be less, and will vary based on as-built dimensions of the components, fuel type, and the presence of fuel spacers and non-fuel hardware, as applicable.

TABLE 2.0.3 (continued)  
HI-TRAC TRANSFER CASK DESIGN CRITERIA SUMMARY

Type	Criteria	Basis	FSAR Reference
<b>Design-Basis (Postulated) Accident Design Events and Conditions:</b>			
		10CFR72.24(d)(2) & 10CFR72.94	
Side Drop	42 in.	-	Section 2.2.3.1
Fire			
Duration	4.8 minutes	10CFR72.122(c)	Section 2.2.3.3
Temperature	1,475° F	10CFR72.122(c)	Section 2.2.3.3
Fuel Rod Rupture	See Table 2.0.1		Section 2.2.3.8
<b>Design-Basis Natural Phenomenon Design Events and Conditions:</b>			
		10CFR72.92 & 10CFR72.122(b)(2)	
Missiles			Section 2.2.3.5
Automobile			
Weight	1800 kg	NUREG-0800	Table 2.2.5
Velocity	126 mph	NUREG-0800	Table 2.2.5
Rigid Solid Steel Cylinder			
Weight	125 kg	NUREG-0800	Table 2.2.5
Velocity	126 mph	NUREG-0800	Table 2.2.5
Diameter	8 in.	NUREG-0800	Table 2.2.5
Steel Sphere			
Weight	0.22 kg	NUREG-0800	Table 2.2.5
Velocity	126 mph	NUREG-0800	Table 2.2.5
Diameter	1 in.	NUREG-0800	Table 2.2.5
<b>Load Combinations:</b>	See Table 2.2.14 and Table 3.1.5	ANSI/ANS-57.9 & NUREG-1536	Section 2.2.7



TABLE 2.0.4  
LIMITING DESIGN PARAMETERS FOR ISFSI PADS AND ANCHOR STUDS FOR HI-STORM 100A

Item	Maximum Permitted Value†	Minimum Permitted Value
ISFSI PAD		
Pad Thickness	---	48 inches
Subgrade Young's Modulus from Static Tests (needed if pad is not founded on rock)	---	10,000 psi
Concrete compressive strength at 28 days	---	4,000 psi
ANCHOR STUDS		
Yield Strength at Ambient Temperature	None	80,000 psi
Ultimate Strength at Ambient Temperature	None	125,000 psi
Initial Stud Tension	65 ksi	55 ksi

---

† Pad and anchor stud parameters to be determined site-specifically, except where noted.

TABLE 2.0.5  
ISFSI PAD REQUIREMENTS FOR FREE-STANDING AND ANCHORED HI-STORM INSTALLATION

Item	Free-Standing	Anchored	Comments
1. Interface between cask and ISFSI	Contact surface between cask and top surface of ISFSI pad	Same as free-standing with the addition of the bearing surface between the anchor stud nut and the overpack baseplate. (The interface between the anchor stud and the anchor receptacle is at the applicable threaded or bearing surface).	All components below the top surface of the ISFSI pad and in contact with the pad concrete are part of the pad design. A non-integral component such as the anchor stud is not part of the embedment even though it may be put in place when the ISFSI pad is formed. The embedment for the load transfer from the anchor studs to the concrete ISFSI pad shall be exclusively cast-in-place.
2. Applicable ACI Code	At the discretion of the ISFSI owner. ACI-318 and ACI-349 are available candidate codes.	ACI-349-97. A later edition of this Code may be used if a written reconciliation is performed.	ACI-349-97 recognizes increased structural role of the ISFSI pad in an anchored cask storage configuration and imposes requirements on embedment design.
3. Limitations on the pad design parameters	Per Table 2.2.9	Per Table 2.0.4	In free-standing cask storage, the non-mechanistic tipover requirement limits the stiffness of the pad. In the anchored storage configuration, increased pad stiffness is permitted; however, the permissible HI-STORM carry height is reduced.
4. HI-STORM Carry Height	11 inches (for ISFSI pad parameter Set A or Set B) or, otherwise, site-specific. Not applicable if the cask is lifted with a device designed in accordance with ANSI N14.6 and having redundant drop protection features.	Determined site-specifically. Not applicable if the cask is lifted with a device designed in accordance with ANSI N14.6 and having redundant drop protection features.	Appendix 3.A provides the technical basis for free-standing installation. Depending on the final ISFSI pad configuration (thickness, concrete strength, subgrade, etc.), and the method of transport, an allowable carry height may need to be established.

TABLE 2.0.5 (continued)  
ISFSI PAD REQUIREMENTS FOR FREE-STANDING AND ANCHORED HI-STORM INSTALLATION

Item	Free-Standing	Anchored	Comments
5. Maximum seismic input on the pad/cask contact surface. $G_H$ is the vectorial sum of the two horizontal ZPAs and $G_V$ is the vertical ZPA	$G_H + \mu G_V \leq \mu$ (see note 1 below)	$G_H \leq 2.12$  AND  $G_V \leq 1.5$	
6. Required minimum value of cask to pad static coefficient of friction ( $\mu$ , must be confirmed by testing if a value greater than 0.53 is used).	Greater than or equal to 0.53 (per Table 2.2.9).	Not applicable	
7. Applicable Wind and Large Missile Loads	Per Table 2.2.4, missile and wind loading different from the tabulated values, require 10CFR 72.48 evaluation	The maximum overturning moment at the base of the cask due to lateral missile and/or wind action must be less than $1 \times 10^7$ ft-lb.	The bases are provided in Section 3.4.8 for free-standing casks; the limit for anchored casks ensures that the anchorage system will have the same structural margins established for seismic loading.
8. Small and medium missiles (penetrant missile)	Per Table 2.2.5, missiles and wind loading different from the tabulated value, require 10CFR 72.48 evaluation.	Same as for free-standing cask construction.	
9. Design Loadings for the ISFSI Pad	Per load combinations in Section 2.0.4 using site-specific load.	Same as for free-standing cask.	

Note 1 –  $G_H$  and  $G_V$  may be the coincident values of the instantaneous horizontal and vertical accelerations, and the inequality shall be evaluated at each time step.

## 2.1 SPENT FUEL TO BE STORED

### 2.1.1 Determination of The Design Basis Fuel

The HI-STORM 100 System is designed to store most types of fuel assemblies generated in the commercial U.S. nuclear industry. Boiling-water reactor (BWR) fuel assemblies have been supplied by The General Electric Company (GE), Siemens, Exxon Nuclear, ANF, UNC, ABB Combustion Engineering, and Gulf Atomic. Pressurized-water reactor (PWR) fuel assemblies are generally supplied by Westinghouse, Babcock & Wilcox, ANF, and ABB Combustion Engineering. ANF, Exxon, and Siemens are historically the same manufacturing company under different ownership. Within this report, SPC is used to designate fuel manufactured by ANF, Exxon, or Siemens. Publications such as Refs. [2.1.1] and [2.1.2] provide a comprehensive description of fuel discharged from U.S. reactors. A central object in the design of the HI-STORM 100 System is to ensure that a majority of SNF discharged from the U.S. reactors can be stored in one of the MPCs.

The cell openings and lengths in the fuel basket have been sized to accommodate the BWR and PWR assemblies listed in Refs. [2.1.1] and [2.1.2] except as noted below. Similarly, the cavity length of the multi-purpose canisters has been set at a dimension which permits storing most types of PWR fuel assemblies and BWR fuel assemblies with or without fuel channels. The one exception is as follows:

- i. The South Texas Units 1 & 2 SNF, and CE 16x16 System 80 SNF are too long to be accommodated in the available MPC cavity length.

In addition to satisfying the cross sectional and length compatibility, the active fuel region of the SNF must be enveloped in the axial direction by the neutron absorber located in the MPC fuel basket. Alignment of the neutron absorber with the active fuel region is ensured by the use of upper and lower fuel spacers suitably designed to support the bottom and restrain the top of the fuel assembly. The spacers axially position the SNF assembly such that its active fuel region is properly aligned with the neutron absorber in the fuel basket. Figure 2.1.5 provides a pictorial representation of the fuel spacers positioning the fuel assembly active fuel region. Both the upper and lower fuel spacers are designed to perform their function under normal, off-normal, and accident conditions of storage.

In summary, the geometric compatibility of the SNF with the MPC designs does not require the definition of a design basis fuel assembly. This, however, is not the case for structural, confinement, shielding, thermal-hydraulic, and criticality criteria. In fact, a particular fuel type in a category (PWR or BWR) may not control the cask design in all of the above-mentioned criteria. To ensure that no SNF listed in Refs. [2.1.1] and [2.1.2] which is geometrically admissible in the MPC is precluded, it is necessary to determine the governing fuel specification for each analysis criterion. To make the necessary determinations, potential candidate fuel assemblies for each qualification criterion were considered. Table 2.1.1 lists the PWR fuel assemblies that were evaluated. These fuel assemblies were evaluated to define the governing design criteria for PWR fuel. The BWR fuel assembly designs evaluated are listed in Table 2.1.2. Tables 2.1.3 and 2.1.4 provide the fuel characteristics determined to be acceptable for storage in the HI-STORM 100 System. Section 2.1.9 summarizes the authorized contents for the HI-STORM 100 System. Any fuel assembly that has fuel characteristics

within the range of Tables 2.1.3 and 2.1.4 and meets the other limits specified in Section 2.1.9 is acceptable for storage in the HI-STORM 100 System. Tables 2.1.3 and 2.1.4 present the groups of fuel assembly types defined as "array/classes" as described in further detail in Chapter 6. Table 2.1.5 lists the BWR and PWR fuel assembly designs which are found to govern for three qualification criteria, namely reactivity, shielding, and thermal. Substantiating results of analyses for the governing assembly types are presented in the respective chapters dealing with the specific qualification topic. Additional information on the design basis fuel definition is presented in the following subsections.

### 2.1.2 Intact SNF Specifications

Intact fuel assemblies are defined as fuel assemblies without known or suspected cladding defects greater than pinhole leaks and hairline cracks, and which can be handled by normal means. The design payload for the HI-STORM 100 System is intact ZR or stainless steel (SS) clad fuel assemblies with the characteristics listed in Tables 2.1.17 through 2.1.24.

Intact fuel assemblies without fuel rods in fuel rod locations cannot be loaded into the HI-STORM 100 unless dummy fuel rods, which occupy a volume greater than or equal to the original fuel rods, replace the missing rods prior to loading. Any intact fuel assembly that falls within the geometric, thermal, and nuclear limits established for the design basis intact fuel assembly, as defined in Section 2.1.9 can be safely stored in the HI-STORM 100 System.

The range of fuel characteristics specified in Tables 2.1.3 and 2.1.4 have been evaluated in this FSAR and are acceptable for storage in the HI-STORM 100 System within the decay heat, burnup, and cooling time limits specified in Section 2.1.9 for intact fuel assemblies.

### 2.1.3 Damaged SNF and Fuel Debris Specifications

Damaged fuel and fuel debris are defined in Table 1.0.1.

To aid in loading and unloading, damaged fuel assemblies and fuel debris will be loaded into stainless steel damaged fuel containers (DFCs) provided with mesh screens having between 40x40 and 250x250 openings per inch, for storage in the HI-STORM 100 System (see Figures 2.1.1 and 2.1.2B, C, and D). The MPC-24E and MPC 32 are designed to accommodate PWR damaged fuel. The MPC-24EF and MPC-32F are designed to accommodate PWR damaged fuel and fuel debris. The MPC-68 is designed to accommodate BWR damaged fuel. The MPC-68F and MPC-68FF are designed to accommodate BWR damaged fuel and fuel debris. The appropriate structural, thermal, shielding, criticality, and confinement analyses have been performed to account for damaged fuel and fuel debris and are described in their respective chapters that follow. The limiting design characteristics for damaged fuel assemblies and restrictions on the number and location of damaged fuel containers authorized for loading in each MPC model are provided in Section 2.1.9. Dresden Unit 1 fuel assemblies contained in Transnuclear-designed damaged fuel canisters and one Dresden Unit 1 thoria rod canister have been approved for storage directly in the HI-STORM 100 System without re-packaging (see Figures 2.1.2 and 2.1.2A).

MPC contents classified as fuel debris are required to be stored in DFCs and in the applicable "F" model MPC as specified in Section 2.1.9. The "F"(or "FF") indicates the MPC is qualified for storage of intact fuel, damaged fuel, and fuel debris, in quantities and locations specified in Section 2.1.9. The basket designs for the standard and "F" model MPCs are identical. The lid and shell designs of the "F" models are unique in that the upper shell portion of the canister is thickened for additional strength needed under hypothetical accident conditions of transportation under 10 CFR 71. This design feature is not required for dry storage, but must be considered in fuel loading for dry storage to ensure the dual purpose function of the MPC by eliminating the need to re-package the fuel for transportation. Figure 2.1.9 shows the details of the differences between the standard and "F" model MPC shells. These details are common for both the PWR and BWR series MPC models.

#### 2.1.4 Deleted

#### 2.1.5 Structural Parameters for Design Basis SNF

The main physical parameters of an SNF assembly applicable to the structural evaluation are the fuel assembly length, envelope (cross sectional dimensions), and weight. These parameters, which define the mechanical and structural design, are specified in Section 2.1.9. The centers of gravity reported in Section 3.2 are based on the maximum fuel assembly weight. Upper and lower fuel spacers (as appropriate) maintain the axial position of the fuel assembly within the MPC basket and, therefore, the location of the center of gravity. The upper and lower fuel spacers are designed to withstand normal, off-normal, and accident conditions of storage. An axial clearance of approximately 2 to 2-1/2 inches is provided to account for the irradiation and thermal growth of the fuel assemblies. The suggested upper and lower fuel spacer lengths are listed in Tables 2.1.9 and 2.1.10. In order to qualify for storage in the MPC, the SNF must satisfy the physical parameters listed in Section 2.1.9.

#### 2.1.6 Thermal Parameters for Design Basis SNF

The principal thermal design parameter for the stored fuel is the peak fuel cladding temperature, which is a function of the maximum heat generation rate per assembly and the decay heat removal capabilities of the HI-STORM 100 System. No attempt is made to link the maximum allowable decay heat per fuel assembly with burnup, enrichment, or cooling time. Rather, the decay heat per fuel assembly is adjusted to yield peak fuel cladding temperatures with an allowance for margin to the temperature limit. The same fuel assembly decay heats are used for all fuel assembly designs within a given class of fuel assemblies (i.e., ZR clad PWR, stainless steel clad BWR, etc.).

To ensure the permissible fuel cladding temperature limits are not exceeded, Section 2.1.9 specifies the allowable decay heat per assembly for each MPC model. For both uniform and regionalized loading of moderate and high burnup fuel assemblies, the allowable decay heat per assembly is presented in Section 2.1.9.

Section 2.1.9 also includes separate cooling time, burnup, and decay heat limits for uniform fuel loading and regionalized fuel loading. Regionalized loading allows higher heat emitting fuel assemblies to be stored in the center fuel storage locations than would otherwise be authorized for storage under uniform loading conditions.

The fuel cladding temperature is also affected by the heat transfer characteristics of the fuel assemblies. There is no single fuel assembly design used in all thermal calculations that is bounding of all others. Instead, each thermal calculation, comprising the overall thermal analysis presented in Chapter 4, was performed using the fuel assembly design that results in the most conservative result for the individual calculation. By always using the fuel assembly design that is most conservative for a particular calculation, it is ensured that each calculation is bounding for all fuel assembly designs. The bounding fuel assembly design for each thermal calculation and fuel type is provided in Table 2.1.5.

Finally, the axial variation in the heat generation rate in the design basis fuel assembly is defined based on the axial burnup distribution. For this purpose, the data provided in Refs. [2.1.7] and [2.1.8] are utilized and summarized in Table 2.1.11 and Figures 2.1.3 and 2.1.4 for reference. These distributions are representative of fuel assemblies with the design basis burnup levels considered. These distributions are used for analyses only, and do not provide a criteria for fuel assembly acceptability for storage in the HI-STORM 100 System.

Except for MPC-68F, fuel may be stored in the MPC using one of two storage strategies, namely, uniform loading and regionalized loading. Uniform loading allows storage of any fuel assembly in any fuel storage location, subject to additional restrictions, such as those for loading of fuel assemblies containing non-fuel hardware as defined in Table 1.0.1. Regionalized fuel loading allows for higher heat emitting fuel assemblies to be stored in the central core basket storage locations (inner region) with lower heat emitting fuel assemblies in the peripheral fuel storage locations (outer region). Regionalized loading allows storage of higher heat emitting fuel assemblies than would otherwise be permitted using the uniform loading strategy. The definition of the regions for each MPC model provided in Table 2.1.13. Regionalized fuel loading is not permitted in MPC-68F.

#### 2.1.7 Radiological Parameters for Design Basis SNF

The principal radiological design criteria for the HI-STORM 100 System are the 10CFR72.104 site boundary dose rate limits and maintaining operational dose rates as low as reasonably achievable (ALARA). The radiation dose is directly affected by the gamma and neutron source terms of the SNF assembly.

The gamma and neutron sources are separate and are affected differently by enrichment, burnup, and cooling time. It is recognized that, at a given burnup, the radiological source terms increase monotonically as the initial enrichment is reduced. The shielding design basis fuel assembly, therefore, is evaluated at conservatively high burnups, low cooling times, and low enrichments, as discussed in Chapter 5. The shielding design basis fuel assembly thus bounds all other fuel assemblies.

The design basis dose rates can be met by a variety of burnup levels and cooling times. Section 2.1.9 provides the procedure for determining burnup and cooling time limits for all of the authorized fuel assembly array/classes for both uniform fuel loading and regionalized loading. Table 2.1.11 and Figures 2.1.3 and 2.1.4 provide the axial distribution for the radiological source terms for PWR and BWR fuel assemblies based on the axial burnup distribution. The axial burnup distributions are representative of fuel assemblies with the design basis burnup levels considered. These distributions

are used for analyses only, and do not provide a criteria for fuel assembly acceptability for storage in the HI-STORM 100 System.

Thoria rods placed in Dresden Unit 1 Thoria Rod Canisters meeting the requirements of Table 2.1.12 and Dresden Unit 1 fuel assemblies with one Antimony-Beryllium neutron source have been qualified for storage. Up to one Thoria Rod Canister is authorized for storage in combination with other intact and damaged fuel, and fuel debris as specified in Section 2.1.9.

Non-fuel hardware, as defined in Table 1.0.1, has been evaluated and is authorized for storage in the PWR MPCs as specified in Section 2.1.9.

### 2.1.8 Criticality Parameters for Design Basis SNF

As discussed earlier, the MPC-68, MPC-68F, MPC-68FF, MPC-32 and MPC-32F feature a basket without flux traps. In the aforementioned baskets, there is one panel of neutron absorber between two adjacent fuel assemblies. The MPC-24, MPC-24E, and MPC-24EF employ a construction wherein two neighboring fuel assemblies are separated by two panels of neutron absorber with a water gap between them (flux trap construction).

The minimum  $^{10}\text{B}$  areal density in the neutron absorber panels for each MPC model is shown in Table 2.1.15.

For all MPCs, the  $^{10}\text{B}$  areal density used for the criticality analysis is conservatively established below the minimum values shown in Table 2.1.15. For Boral, the value used in the analysis is 75% of the minimum value, while for METAMIC, it is 90% of the minimum value. This is consistent with NUREG-1536 [2.1.5] which suggests a 25% reduction in  $^{10}\text{B}$  areal density credit when subject to standard acceptance tests, and which allows a smaller reduction when more comprehensive tests of the areal density are performed.

The criticality analyses for the MPC-24, MPC-24E and MPC-24EF (all with higher enriched fuel) and for the MPC-32 and MPC-32F were performed with credit taken for soluble boron in the MPC water during wet loading and unloading operations. Table 2.1.14 and 2.1.16 provide the required soluble boron concentrations for these MPCs.

### 2.1.9 Summary of Authorized Contents

Tables 2.1.3, 2.1.4, 2.1.12, and 2.1.17 through 2.1.29 together specify the limits for spent fuel and non-fuel hardware authorized for storage in the HI-STORM 100 System. The limits in these tables are derived from the safety analyses described in the following chapters of this FSAR. Fuel classified as damaged fuel assemblies or fuel debris must be stored in damaged fuel containers for storage in the HI-STORM 100 System.

Tables 2.1.17 through 2.1.24 are the baseline tables that specify the fuel assembly limits for each of the MPC models, with appropriate references to the other tables in this section for certain other limits. Tables 2.1.17 through 2.1.24 refer to Section 2.1.9.1 for ZR-clad fuel limits on minimum cooling time, maximum decay heat, and maximum burnup for uniform and regionalized fuel loading.



Limits on decay heat, burnup, and cooling time for stainless steel-clad fuel are provided in Tables 2.1.17 through 2.1.24.

#### 2.1.9.1 Decay Heat, Burnup, and Cooling Time Limits for ZR-Clad Fuel

Each ZR-clad fuel assembly and any PWR integral non-fuel hardware (NFH) to be stored in the HI-STORM 100 System must meet the following limits, in addition to meeting the physical limits specified elsewhere in this section, to be authorized for storage in the HI-STORM 100 System. The contents of each fuel storage location (fuel assembly and NFH) to be stored must be verified to have, as applicable:

- A decay heat less than or equal to the maximum allowable value.
- An assembly average enrichment greater than or equal to the minimum value used in determining the maximum allowable burnup.
- A burnup less than or equal to the maximum allowable value.
- A cooling time greater than or equal to the minimum allowable value.

The maximum allowable ZR-clad fuel storage location decay heat values are determined using the methodology described in Section 2.1.9.1.1 or 2.1.9.1.2 depending on whether uniform fuel loading or regionalized fuel loading is being implemented<sup>†</sup>. The decay heat limits are independent of burnup, cooling time, or enrichment and are based strictly on the thermal analysis described in Chapter 4. Decay heat limits must be met for all contents in a fuel storage location (i.e., fuel and PWR non-fuel hardware, as applicable).

The maximum allowable average burnup per fuel storage location is determined by calculation as a function of minimum enrichment, maximum allowable decay heat, and minimum cooling time from 3 to 20 years, as described in Section 2.1.9.1.3.

Section 12.2.10 describes how compliance with these limits may be verified, including practical examples.

##### 2.1.9.1.1 Uniform Fuel Loading Decay Heat Limits for ZR-Clad Fuel

Table 2.1.26 provides the maximum allowable decay heat per fuel storage location for ZR-clad fuel in uniform fuel loading for each MPC model.

---

<sup>†</sup> Note that the stainless steel-clad fuel limits apply to all fuel in the MPC, if a mixture of stainless steel and ZR-clad fuel is stored in the same MPC. The stainless steel-clad fuel assembly decay heat limits may be found in Table 2.1.17 through 2.1.24

### 2.1.9.1.2 Regionalized Fuel Loading Decay Heat Limits for ZR-Clad Fuel

Table 2.1.27 provides the maximum allowable decay heat per fuel storage location for ZR-clad fuel in both the inner and outer regions for regionalized fuel loading in each MPC model.

### 2.1.9.1.3 Burnup Limits as a Function of Cooling Time for ZR-Clad Fuel

The maximum allowable ZR-clad fuel assembly average burnup varies with the following parameters, based on the shielding analysis in Chapter 5:

- Minimum required fuel assembly cooling time
- Maximum allowable fuel assembly decay heat
- Minimum fuel assembly average enrichment

The calculation described in this section is used to determine the maximum allowable fuel assembly burnup for minimum cooling times between 3 and 20 years, using maximum decay heat and minimum enrichment as input values. This calculation may be used to create multiple burnup versus cooling time tables for a particular fuel assembly array/class and different minimum enrichments. The allowable maximum burnup for a specific fuel assembly may be calculated based on the assembly's particular enrichment and cooling time.

- (i) Choose a fuel assembly minimum enrichment,  $E_{235}$ .
- (ii) Calculate the maximum allowable fuel assembly average burnup for a minimum cooling time between 3 and 20 years using the equation below:

$$Bu = (A \times q) + (B \times q^2) + (C \times q^3) + [D \times (E_{235})^2] + (E \times q \times E_{235}) + (F \times q^2 \times E_{235}) + G$$

Equation 2.1.9.3

Where:

Bu = Maximum allowable assembly average burnup (MWD/MTU)

q = Maximum allowable decay heat per fuel storage location determined in Section 2.1.9.1 or 2.1.9.2 (kW)

$E_{235}$  = Minimum fuel assembly average enrichment (wt. %  $^{235}\text{U}$ )  
(e.g., for 4.05 wt. %, use 4.05)

A through G = Coefficients from Tables 2.1.28 or 2.1.29 for the applicable fuel assembly array/class and minimum cooling time.

#### 2.1.9.1.4 Other Considerations

In computing the allowable maximum fuel storage location decay heats and fuel assembly average burnups, the following requirements apply:

- Calculated burnup limits shall be rounded down to the nearest integer
- Calculated burnup limits greater than 68,200 MWD/MTU for PWR fuel and 65,000 MWD/MTU for BWR fuel must be reduced to be equal to these values.
- Linear interpolation of calculated burnups between cooling times for a given fuel assembly maximum decay heat and minimum enrichment is permitted. For example, the allowable burnup for a minimum cooling time of 4.5 years may be interpolated between those burnups calculated for 4 and 5 years.
- ZR-clad fuel assemblies must have a minimum enrichment, as defined in Table 1.0.1, greater than or equal to the value used in determining the maximum allowable burnup per Section 2.1.9.1.3 to be authorized for storage in the MPC.
- When complying with the maximum fuel storage location decay heat limits, users must account for the decay heat from both the fuel assembly and any PWR non-fuel hardware, as applicable for the particular fuel storage location, to ensure the decay heat emitted by all contents in a storage location does not exceed the limit.

Section 12.2.10 provides a practical example of determining fuel storage location decay heat, burnup, and cooling time limits and verifying compliance for a set of example fuel assemblies.

Table 2.1.1

PWR FUEL ASSEMBLIES EVALUATED TO DETERMINE DESIGN BASIS SNF

Assembly Class	Array Type
B&W 15x15	All
B&W 17x17	All
CE 14x14	All
CE 16x16	All except System 80 <sup>TM</sup>
WE 14x14	All
WE 15x15	All
WE 17x17	All
St. Lucie	All
Ft. Calhoun	All
Haddam Neck (Stainless Steel Clad)	All
San Onofre 1 (Stainless Steel Clad)	All
Indian Point 1	All

Table 2.1.2

BWR FUEL ASSEMBLIES EVALUATED TO DETERMINE DESIGN BASIS SNF

Assembly Class	Array Type			
GE BWR/2-3	All 7x7	All 8x8	All 9x9	All 10x10
GE BWR/4-6	All 7x7	All 8x8	All 9x9	All 10x10
Humboldt Bay	All 6x6	All 7x7 (ZR Clad)		
Dresden-1	All 6x6	All 8x8		
LaCrosse (Stainless Steel Clad)	All			

Table 2.1.3  
PWR FUEL ASSEMBLY CHARACTERISTICS (Note 1)

<b>Fuel Assembly Array/ Class</b>	<b>14x14 A</b>	<b>14x14 B</b>	<b>14x14 C</b>	<b>14x14 D</b>	<b>14x14E</b>
Clad Material (Note 2)	ZR	ZR	ZR	SS	SS
Design Initial U (kg/assy.) (Note 3)	≤ 365	≤ 412	≤ 438	≤ 400	≤ 206
Initial Enrichment (MPC-24, 24E, and 24EF without soluble boron credit) (wt % <sup>235</sup> U) (Note 7)	≤ 4.6 (24) ≤ 5.0 (24E/24EF)	≤ 4.6 (24) ≤ 5.0 (24E/24EF)	≤ 4.6 (24) ≤ 5.0 (24E/24EF)	≤ 4.0 (24) ≤ 5.0 (24E/24EF)	N/A N/A
Initial Enrichment (MPC-24, 24E, 24EF, 32 or 32F with soluble boron credit - see Note 5) (wt % <sup>235</sup> U)	≤ 5.0	≤ 5.0	≤ 5.0	≤ 5.0	≤ 4.5 (MPC-32/32F only - Note 9)
No. of Fuel Rod Locations	179	179	176	180	173
Fuel Clad O.D. (in.)	≥ 0.400	≥ 0.417	≥ 0.440	≥ 0.422	≥ 0.3415
Fuel Clad I.D. (in.)	≤ 0.3514	≤ 0.3734	≤ 0.3880	≤ 0.3890	≤ 0.3175
Fuel Pellet Dia. (in.) (Note 8)	≤ 0.3444	≤ 0.3659	≤ 0.3805	≤ 0.3835	≤ 0.3130
Fuel Rod Pitch (in.)	≤ 0.556	≤ 0.556	≤ 0.580	≤ 0.556	Note 6
Active Fuel Length (in.)	≤ 150	≤ 150	≤ 150	≤ 144	≤ 102
No. of Guide and/or Instrument Tubes	17	17	5 (Note 4)	16	0
Guide/Instrument Tube Thickness (in.)	≥ 0.017	≥ 0.017	≥ 0.038	≥ 0.0145	N/A

Table 2.1.3 (continued)  
PWR FUEL ASSEMBLY CHARACTERISTICS (Note 1)

<b>Fuel Assembly Array/Class</b>	<b>15x15 A</b>	<b>15x15 B</b>	<b>15x15 C</b>	<b>15x15 D</b>	<b>15x15 E</b>	<b>15x15 F</b>
Clad Material (Note 2)	ZR	ZR	ZR	ZR	ZR	ZR
Design Initial U (kg/assy.) (Note 3)	≤ 473	≤ 473	≤ 473	≤ 495	≤ 495	≤ 495
Initial Enrichment (MPC-24, 24E, and 24EF without soluble boron credit) (wt % <sup>235</sup> U) (Note 7)	≤ 4.1 (24) ≤ 4.5 (24E/24EF)	≤ 4.1 (24) ≤ 4.5 (24E/24EF)	≤ 4.1 (24) ≤ 4.5 (24E/24EF)	≤ 4.1 (24) ≤ 4.5 (24E/24EF)	≤ 4.1 (24) ≤ 4.5 (24E/24EF)	≤ 4.1 (24) ≤ 4.5 (24E/24EF)
Initial Enrichment (MPC-24, 24E, 24EF, 32 or 32F with soluble boron credit – see Note 5) (wt % <sup>235</sup> U)	≤ 5.0	≤ 5.0	≤ 5.0	≤ 5.0	≤ 5.0	≤ 5.0
No. of Fuel Rod Locations	204	204	204	208	208	208
Fuel Clad O.D. (in.)	≥ 0.418	≥ 0.420	≥ 0.417	≥ 0.430	≥ 0.428	≥ 0.428
Fuel Clad I.D. (in.)	≤ 0.3660	≤ 0.3736	≤ 0.3640	≤ 0.3800	≤ 0.3790	≤ 0.3820
Fuel Pellet Dia. (in.) (Note 8)	≤ 0.3580	≤ 0.3671	≤ 0.3570	≤ 0.3735	≤ 0.3707	≤ 0.3742
Fuel Rod Pitch (in.)	≤ 0.550	≤ 0.563	≤ 0.563	≤ 0.568	≤ 0.568	≤ 0.568
Active Fuel Length (in.)	≤ 150	≤ 150	≤ 150	≤ 150	≤ 150	≤ 150
No. of Guide and/or Instrument Tubes	21	21	21	17	17	17
Guide/Instrument Tube Thickness (in.)	≥ 0.0165	≥ 0.015	≥ 0.0165	≥ 0.0150	≥ 0.0140	≥ 0.0140

Table 2.1.3 (continued)  
PWR FUEL ASSEMBLY CHARACTERISTICS (Note 1)

<b>Fuel Assembly Array and Class</b>	<b>15x15 G</b>	<b>15x15H</b>	<b>16x16 A</b>	<b>17x17A</b>	<b>17x17 B</b>	<b>17x17 C</b>
Clad Material (Note 2)	SS	ZR	ZR	ZR	ZR	ZR
Design Initial U (kg/assy.) (Note 3)	≤ 420	≤ 495	≤ 448	≤ 433	≤ 474	≤ 480
Initial Enrichment (MPC-24, 24E, and 24EF without soluble boron credit) (wt % <sup>235</sup> U) (Note 7)	≤ 4.0 (24) ≤ 4.5 (24E/24EF)	≤ 3.8 (24) ≤ 4.2 (24E/24EF)	≤ 4.6 (24) ≤ 5.0 (24E/24EF)	≤ 4.0 (24) ≤ 4.4 (24E/24EF)	≤ 4.0 (24) ≤ 4.4 (24E/24EF)	≤ 4.0 (24) ≤ 4.4 (24E/24EF)
Initial Enrichment (MPC-24, 24E, 24EF, 32 or 32F with soluble boron credit – see Note 5) (wt % <sup>235</sup> U)	≤ 5.0	≤ 5.0	≤ 5.0	≤ 5.0	≤ 5.0	≤ 5.0
No. of Fuel Rod Locations	204	208	236	264	264	264
Fuel Clad O.D. (in.)	≥ 0.422	≥ 0.414	≥ 0.382	≥ 0.360	≥ 0.372	≥ 0.377
Fuel Clad I.D. (in.)	≤ 0.3890	≤ 0.3700	≤ 0.3320	≤ 0.3150	≤ 0.3310	≤ 0.3330
Fuel Pellet Dia. (in.) (Note 8)	≤ 0.3825	≤ 0.3622	≤ 0.3255	≤ 0.3088	≤ 0.3232	≤ 0.3252
Fuel Rod Pitch (in.)	≤ 0.563	≤ 0.568	≤ 0.506	≤ 0.496	≤ 0.496	≤ 0.502
Active Fuel length (in.)	≤ 144	≤ 150	≤ 150	≤ 150	≤ 150	≤ 150
No. of Guide and/or Instrument Tubes	21	17	5 (Note 4)	25	25	25
Guide/Instrument Tube Thickness (in.)	≥ 0.0145	≥ 0.0140	≥ 0.0400	≥ 0.016	≥ 0.014	≥ 0.020

HOLTEC INTERNATIONAL COPYRIGHTED MATERIAL



Table 2.1.3 (continued)  
PWR FUEL ASSEMBLY CHARACTERISTICS

Notes:

1. All dimensions are design nominal values. Maximum and minimum dimensions are specified to bound variations in design nominal values among fuel assemblies within a given array/class.
2. See Table 1.0.1 for the definition of "ZR."
3. Design initial uranium weight is the nominal uranium weight specified for each assembly by the fuel manufacturer or reactor user. For each PWR fuel assembly, the total uranium weight limit specified in this table may be increased up to 2.0 percent for comparison with users' fuel records to account for manufacturer's tolerances.
4. Each guide tube replaces four fuel rods.
5. Soluble boron concentration per Tables 2.1.14 and 2.1.16, as applicable.
6. This fuel assembly array/class includes only the Indian Point Unit 1 fuel assembly. This fuel assembly has two pitches in different sectors of the assembly. These pitches are 0.441 inches and 0.453 inches.
7. For those MPCs loaded with both intact fuel assemblies and damaged fuel assemblies or fuel debris, the maximum initial enrichment of the intact fuel assemblies, damaged fuel assemblies and fuel debris is 4.0 wt.%  $^{235}\text{U}$ .
8. Annular fuel pellets are allowed in the top and bottom 12" of the active fuel length.
9. This fuel assembly array/class includes only the Indian Point Unit 1 fuel assembly. This assembly class has been analyzed throughout this FSAR in all PWR MPCs, however it is only to be loaded into the MPC-32/32F.

Table 2.1.4  
BWR FUEL ASSEMBLY CHARACTERISTICS (Note 1)

Fuel Assembly Array and Class	6x6 A	6x6 B	6x6 C	7x7 A	7x7 B	8x8 A
Clad Material (Note 2)	ZR	ZR	ZR	ZR	ZR	ZR
Design Initial U (kg/assy.) (Note 3)	≤ 110	≤ 110	≤ 110	≤ 100	≤ 198	≤ 120
Maximum Planar-Average Initial Enrichment (wt.% <sup>235</sup> U) (Note 14)	≤ 2.7	≤ 2.7 for UO <sub>2</sub> rods. See Note 4 for MOX rods	≤ 2.7	≤ 2.7	≤ 4.2	≤ 2.7
Initial Maximum Rod Enrichment (wt.% <sup>235</sup> U)	≤ 4.0	≤ 4.0	≤ 4.0	≤ 5.5	≤ 5.0	≤ 4.0
No. of Fuel Rod Locations	35 or 36	35 or 36 (up to 9 MOX rods)	36	49	49	63 or 64
Fuel Clad O.D. (in.)	≥ 0.5550	≥ 0.5625	≥ 0.5630	≥ 0.4860	≥ 0.5630	≥ 0.4120
Fuel Clad I.D. (in.)	≤ 0.5105	≤ 0.4945	≤ 0.4990	≤ 0.4204	≤ 0.4990	≤ 0.3620
Fuel Pellet Dia. (in.)	≤ 0.4980	≤ 0.4820	≤ 0.4880	≤ 0.4110	≤ 0.4910	≤ 0.3580
Fuel Rod Pitch (in.)	≤ 0.710	≤ 0.710	≤ 0.740	≤ 0.631	≤ 0.738	≤ 0.523
Active Fuel Length (in.)	≤ 120	≤ 120	≤ 77.5	≤ 80	≤ 150	≤ 120
No. of Water Rods (Note 11)	1 or 0	1 or 0	0	0	0	1 or 0
Water Rod Thickness (in.)	> 0	> 0	N/A	N/A	N/A	≥ 0
Channel Thickness (in.)	≤ 0.060	≤ 0.060	≤ 0.060	≤ 0.060	≤ 0.120	≤ 0.100

Table 2.1.4 (continued)  
BWR FUEL ASSEMBLY CHARACTERISTICS (Note 1)

Fuel Assembly Array and Class	8x8 B	8x8 C	8x8 D	8x8 E	8x8F	9x9 A
Clad Material (Note 2)	ZR	ZR	ZR	ZR	ZR	ZR
Design Initial U (kg/assy.) (Note 3)	≤ 192	≤ 190	≤ 190	≤ 190	≤ 191	≤ 180
Maximum Planar-Average Initial Enrichment (wt.% <sup>235</sup> U) (Note 14)	≤ 4.2	≤ 4.2	≤ 4.2	≤ 4.2	≤ 4.0	≤ 4.2
Initial Maximum Rod Enrichment (wt.% <sup>235</sup> U)	≤ 5.0	≤ 5.0	≤ 5.0	≤ 5.0	≤ 5.0	≤ 5.0
No. of Fuel Rod Locations	63 or 64	62	60 or 61	59	64	74/66 (Note 5)
Fuel Clad O.D. (in.)	≥ 0.4840	≥ 0.4830	≥ 0.4830	≥ 0.4930	≥ 0.4576	≥ 0.4400
Fuel Clad I.D. (in.)	≤ 0.4295	≤ 0.4250	≤ 0.4230	≤ 0.4250	≤ 0.3996	≤ 0.3840
Fuel Pellet Dia. (in.)	≤ 0.4195	≤ 0.4160	≤ 0.4140	≤ 0.4160	≤ 0.3913	≤ 0.3760
Fuel Rod Pitch (in.)	≤ 0.642	≤ 0.641	≤ 0.640	≤ 0.640	≤ 0.609	≤ 0.566
Design Active Fuel Length (in.)	≤ 150	≤ 150	≤ 150	≤ 150	≤ 150	≤ 150
No. of Water Rods (Note 11)	1 or 0	2	1 - 4 (Note 7)	5	N/A (Note 12)	2
Water Rod Thickness (in.)	≥ 0.034	> 0.00	> 0.00	≥ 0.034	≥ 0.0315	> 0.00
Channel Thickness (in.)	≤ 0.120	≤ 0.120	≤ 0.120	≤ 0.100	≤ 0.055	≤ 0.120

Table 2.1.4 (continued)  
BWR FUEL ASSEMBLY CHARACTERISTICS (Note 1)

Fuel Assembly Array and Class	9x9 B	9x9 C	9x9 D	9x9 E (Note 13)	9x9 F (Note 13)	9x9 G
Clad Material (Note 2)	ZR	ZR	ZR	ZR	ZR	ZR
Design Initial U (kg/assy.) (Note 3)	≤ 180	≤ 182	≤ 182	≤ 183	≤ 183	≤ 164
Maximum Planar-Average Initial Enrichment (wt.% <sup>235</sup> U) (Note 14)	≤ 4.2	≤ 4.2	≤ 4.2	≤ 4.0	≤ 4.0	≤ 4.2
Initial Maximum Rod Enrichment (wt.% <sup>235</sup> U)	≤ 5.0	≤ 5.0	≤ 5.0	≤ 5.0	≤ 5.0	≤ 5.0
No. of Fuel Rod Locations	72	80	79	76	76	72
Fuel Clad O.D. (in.)	≥ 0.4330	≥ 0.4230	≥ 0.4240	≥ 0.4170	≥ 0.4430	≥ 0.4240
Fuel Clad I.D. (in.)	≤ 0.3810	≤ 0.3640	≤ 0.3640	≤ 0.3640	≤ 0.3860	≤ 0.3640
Fuel Pellet Dia. (in.)	≤ 0.3740	≤ 0.3565	≤ 0.3565	≤ 0.3530	≤ 0.3745	≤ 0.3565
Fuel Rod Pitch (in.)	≤ 0.572	≤ 0.572	≤ 0.572	≤ 0.572	≤ 0.572	≤ 0.572
Design Active Fuel Length (in.)	≤ 150	≤ 150	≤ 150	≤ 150	≤ 150	≤ 150
No. of Water Rods (Note 11)	1 (Note 6)	1	2	5	5	1 (Note 6)
Water Rod Thickness (in.)	> 0.00	≥ 0.020	≥ 0.0300	≥ 0.0120	≥ 0.0120	≥ 0.0320
Channel Thickness (in.)	≤ 0.120	≤ 0.100	≤ 0.100	≤ 0.120	≤ 0.120	≤ 0.120

Table 2.1.4 (continued)  
BWR FUEL ASSEMBLY CHARACTERISTICS (Note 1)

<b>Fuel Assembly Array and Class</b>	<b>10x10 A</b>	<b>10x10 B</b>	<b>10x10 C</b>	<b>10x10 D</b>	<b>10x10 E</b>
Clad Material (Note 2)	ZR	ZR	ZR	SS	SS
Design Initial U (kg/assy.) (Note 3)	≤ 188	≤ 188	≤ 179	≤ 125	≤ 125
Maximum Planar-Average Initial Enrichment (wt.% <sup>235</sup> U) (Note 14)	≤ 4.2	≤ 4.2	≤ 4.2	≤ 4.0	≤ 4.0
Initial Maximum Rod Enrichment (wt.% <sup>235</sup> U)	≤ 5.0	≤ 5.0	≤ 5.0	≤ 5.0	≤ 5.0
No. of Fuel Rod Locations	92/78 (Note 8)	91/83 (Note 9)	96	100	96
Fuel Clad O.D. (in.)	≥ 0.4040	≥ 0.3957	≥ 0.3780	≥ 0.3960	≥ 0.3940
Fuel Clad I.D. (in.)	≤ 0.3520	≤ 0.3480	≤ 0.3294	≤ 0.3560	≤ 0.3500
Fuel Pellet Dia. (in.)	≤ 0.3455	≤ 0.3420	≤ 0.3224	≤ 0.3500	≤ 0.3430
Fuel Rod Pitch (in.)	≤ 0.510	≤ 0.510	≤ 0.488	≤ 0.565	≤ 0.557
Design Active Fuel Length (in.)	≤ 150	≤ 150	≤ 150	≤ 83	≤ 83
No. of Water Rods (Note 11)	2	1 (Note 6)	5 (Note 10)	0	4
Water Rod Thickness (in.)	≥ 0.030	> 0.00	≥ 0.031	N/A	≥ 0.022
Channel Thickness (in.)	≤ 0.120	≤ 0.120	≤ 0.055	≤ 0.080	≤ 0.080

Table 2.1.4 (continued)  
BWR FUEL ASSEMBLY CHARACTERISTICS

NOTES:

1. All dimensions are design nominal values. Maximum and minimum dimensions are specified to bound variations in design nominal values among fuel assemblies within a given array/class.
2. See Table 1.0.1 for the definition of "ZR."
3. Design initial uranium weight is the nominal uranium weight specified for each assembly by the fuel manufacturer or reactor user. For each BWR fuel assembly, the total uranium weight limit specified in this table may be increased up to 1.5 percent for comparison with users' fuel records to account for manufacturer tolerances.
4.  $\leq 0.635$  wt. %  $^{235}\text{U}$  and  $\leq 1.578$  wt. % total fissile plutonium ( $^{239}\text{Pu}$  and  $^{241}\text{Pu}$ ), (wt. % of total fuel weight, i.e.,  $\text{UO}_2$  plus  $\text{PuO}_2$ )
5. This assembly class contains 74 total rods; 66 full length rods and 8 partial length rods.
6. Square, replacing nine fuel rods.
7. Variable.
8. This assembly contains 92 total fuel rods; 78 full length rods and 14 partial length rods.
9. This assembly class contains 91 total fuel rods; 83 full length rods and 8 partial length rods.
10. One diamond-shaped water rod replacing the four center fuel rods and four rectangular water rods dividing the assembly into four quadrants.
11. These rods may also be sealed at both ends and contain Zr material in lieu of water.
12. This assembly is known as "QUAD+." It has four rectangular water cross segments dividing the assembly into four quadrants.
13. For the SPC 9x9-5 fuel assembly, each fuel rod must meet either the 9x9E or the 9x9F set of limits or clad O.D., clad I.D., and pellet diameter.
14. For those MPCs loaded with both intact fuel assemblies and damaged fuel assemblies or fuel debris, the maximum planar average initial enrichment for the intact fuel assemblies is limited to 3.7 wt.%  $^{235}\text{U}$ , as applicable.

Table 2.1.5

## DESIGN BASIS FUEL ASSEMBLY FOR EACH DESIGN CRITERION

<b>Criterion</b>	<b>BWR</b>	<b>PWR</b>
Reactivity (Criticality)	GE12/14 10x10 with Partial Length Rods (Array/Class 10x10A)	B&W 15x15 (Array/Class 15x15F)
Shielding	GE 7x7	B&W 15x15
Fuel Assembly Effective Planar Thermal Conductivity	GE-11 9x9	<u>W</u> 17x17 OFA
Fuel Basket Effective Axial Thermal Conductivity	GE 7x7	<u>W</u> 14x14 OFA
MPC Density and Heat Capacity	Dresden 6x6	<u>W</u> 14x14 OFA
MPC Fuel Basket Axial Resistance to Thermosiphon Flow	GE-11 9x9	<u>W</u> 17x17 OFA

Tables 2.1.6 through 2.1.8

INTENTIONALLY DELETED



Table 2.1.9

## SUGGESTED PWR UPPER AND LOWER FUEL SPACER LENGTHS

Fuel Assembly Type	Assembly Length w/o NFH <sup>1</sup> (in.)	Location of Active Fuel from Bottom (in.)	Max. Active Fuel Length (in.)	Upper Fuel Spacer Length (in.)	Lower Fuel Spacer Length (in.)
CE 14x14	157	4.1	137	9.5	10.0
CE 16x16	176.8	4.7	150	0	0
BW 15x15	165.7	8.4	141.8	6.7	4.1
W 17x17 OFA	159.8	3.7	144	8.2	8.5
W 17x17 Std	159.8	3.7	144	8.2	8.5
W 17x17 VSH	160.1	3.7	144	7.9	8.5
W 15x15	159.8	3.7	144	8.2	8.5
W 14x14 Std	159.8	3.7	145.2	9.2	7.5
W 14x14 OFA	159.8	3.7	144	8.2	8.5
Ft. Calhoun	146	6.6	128	10.25	20.25
St. Lucie 2	158.2	5.2	136.7	10.25	8.05
B&W 15x15 SS	137.1	3.873	120.5	19.25	19.25
W 15x15 SS	137.1	3.7	122	19.25	19.25
W 14x14 SS	137.1	3.7	120	19.25	19.25
Indian Point 1	137.2	17.705	101.5	18.75	20.0

Note: Each user shall specify the fuel spacer length based on their fuel assembly length, presence of a DFC, and allowing an approximate two to 2-1/2 inch gap under the MPC lid. Fuel spacers shall be sized to ensure that the active fuel region of intact fuel assemblies remains within the neutron poison region of the MPC basket with water in the MPC.

<sup>1</sup> NFH is an abbreviation for non-fuel hardware, including control components. Fuel assemblies with control components may require shorter fuel spacers.

Table 2.1.10

## SUGGESTED BWR UPPER AND LOWER FUEL SPACER LENGTHS

<b>Fuel Assembly Type</b>	<b>Assembly Length (in.)</b>	<b>Location of Active Fuel from Bottom (in.)</b>	<b>Max. Active Fuel Length (in.)</b>	<b>Upper Fuel Spacer Length (in.)</b>	<b>Lower Fuel Spacer Length (in.)</b>
GE/2-3	171.2	7.3	150	4.8	0
GE/4-6	176.2	7.3	150	0	0
Dresden 1	134.4	11.2	110	18.0	28.0
Humboldt Bay	95.0	8.0	79	40.5	40.5
Dresden 1 Damaged Fuel or Fuel Debris	142.1 <sup>†</sup>	11.2	110	17.0	16.9
Humboldt Bay Damaged Fuel or Fuel Debris	105.5 <sup>†</sup>	8.0	79	35.25	35.25
LaCrosse	102.5	10.5	83	37.0	37.5

Note: Each user shall specify the fuel spacer length based on their fuel assembly length, presence of a DFC, and allowing an approximate two to 2-1/2 inch gap under the MPC lid. Fuel spacers shall be sized to ensure that the active fuel region of intact fuel assemblies remains within the neutron poison region of the MPC basket with water in the MPC.

<sup>†</sup> Fuel assembly length includes the damaged fuel container.

Table 2.1.11  
NORMALIZED DISTRIBUTION BASED ON BURNUP PROFILE

<b>PWR DISTRIBUTION<sup>1</sup></b>		
<b>Interval</b>	<b>Axial Distance From Bottom of Active Fuel (% of Active Fuel Length)</b>	<b>Normalized Distribution</b>
1	0% to 4-1/6%	0.5485
2	4-1/6% to 8-1/3%	0.8477
3	8-1/3% to 16-2/3%	1.0770
4	16-2/3% to 33-1/3%	1.1050
5	33-1/3% to 50%	1.0980
6	50% to 66-2/3%	1.0790
7	66-2/3% to 83-1/3%	1.0501
8	83-1/3% to 91-2/3%	0.9604
9	91-2/3% to 95-5/6%	0.7338
10	95-5/6% to 100%	0.4670
<b>BWR DISTRIBUTION<sup>2</sup></b>		
<b>Interval</b>	<b>Axial Distance From Bottom of Active Fuel (% of Active Fuel Length)</b>	<b>Normalized Distribution</b>
1	0% to 4-1/6%	0.2200
2	4-1/6% to 8-1/3%	0.7600
3	8-1/3% to 16-2/3%	1.0350
4	16-2/3% to 33-1/3%	1.1675
5	33-1/3% to 50%	1.1950
6	50% to 66-2/3%	1.1625
7	66-2/3% to 83-1/3%	1.0725
8	83-1/3% to 91-2/3%	0.8650
9	91-2/3% to 95-5/6%	0.6200
10	95-5/6% to 100%	0.2200

<sup>1</sup> Reference 2.1.7

<sup>2</sup> Reference 2.1.8

Table 2.1.12

## DESIGN CHARACTERISTICS FOR THORIA RODS IN D-1 THORIA ROD CANISTERS

<b>PARAMETER</b>	<b>MPC-68 or MPC-68F</b>
Cladding Type	Zircaloy
Composition	98.2 wt.% ThO <sub>2</sub> , 1.8 wt.% UO <sub>2</sub> with an enrichment of 93.5 wt. % <sup>235</sup> U
Number of Rods Per Thoria Canister	≤ 18
Decay Heat Per Thoria Canister	≤ 115 watts
Post-Irradiation Fuel Cooling Time and Average Burnup Per Thoria Canister	Cooling time ≥ 18 years and average burnup ≤ 16,000 MWD/MTIHM
Initial Heavy Metal Weight	≤ 27 kg/canister
Fuel Cladding O.D.	≥ 0.412 inches
Fuel Cladding I.D.	≤ 0.362 inches
Fuel Pellet O.D.	≤ 0.358 inches
Active Fuel Length	≤ 111 inches
Canister Weight	≤ 550 lbs., including Thoria Rods
Canister Material	Type 304 SS

Table 2.1.13  
MPC Fuel Loading Regions

<b>MPC MODEL</b>	<b>REGION 1 FUEL STORAGE LOCATIONS*</b>	<b>REGION 2 FUEL STORAGE LOCATIONS</b>
MPC-24, 24E and 24EF	9, 10, 15, and 16	All Other Locations
MPC-32/32F	7, 8, 12 through 15, 18 through 21, 25, and 26	All Other Locations
MPC-68/68F/68FF	11 through 14, 18 through 23, 27 through 32, 37 through 42, 46 through 51, 55 through 58	All Other Locations

\*Note: Refer to Figures 1.2.2 through 1.2.4

Table 2.1.14

## Soluble Boron Requirements for MPC-24/24E/24EF Fuel Wet Loading and Unloading Operations

MPC MODEL	FUEL ASSEMBLY MAXIMUM AVERAGE ENRICHMENT (wt % <sup>235</sup> U)	MINIMUM SOLUBLE BORON CONCENTRATION (ppmb)
MPC-24	All fuel assemblies with initial enrichment <sup>1</sup> less than the prescribed value for soluble boron credit	0
MPC-24	One or more fuel assemblies with an initial enrichment <sup>1</sup> greater than or equal to the prescribed value for no soluble boron credit and $\leq 5.0$ wt. %	$\geq 400$
MPC-24E/24EF	All fuel assemblies with initial enrichment <sup>1</sup> less than the prescribed value for soluble boron credit	0
MPC-24E/24EF	All fuel assemblies classified as intact fuel assemblies and one or more fuel assemblies with an initial enrichment <sup>1</sup> greater than or equal to the prescribed value for no soluble boron credit and $\leq 5.0$ wt. %	$\geq 300$
MPC-24E/24EF	One or more fuel assemblies classified as damaged fuel or fuel debris and one or more fuel assemblies with initial enrichment $> 4.0$ wt.% and $\leq 5.0$ wt.%	$\geq 600$

<sup>1</sup>Refer to Table 2.1.3 for these enrichments.

Table 2.1.15

MINIMUM BORAL <sup>10</sup>B LOADING IN NEUTRON ABSORBER PANELS

MPC MODEL	MINIMUM <sup>10</sup> B LOADING (g/cm <sup>2</sup> )	
	Boral Neutron Absorber Panels	METAMIC Neutron Absorber Panels
MPC-24	0.0267	0.0223
MPC-24E and MPC-24EF	0.0372	0.0310
MPC-32/32F	0.0372	0.0310
MPC-68 and MPC-68FF	0.0372	0.0310
MPC-68F	0.01	N/A (Note 1)

Notes:

1. All MPC-68F canisters are equipped with Boral neutron absorber panels.

Table 2.1.16

Soluble Boron Requirements for MPC-32 and MPC-32F Wet Loading and Unloading Operations

Fuel Assembly Array/Class (Note 2)	All Intact Fuel Assemblies		One or More Damaged Fuel Assemblies or Fuel Debris	
	Max. Initial Enrichment $\leq 4.1$ wt.% $^{235}\text{U}$ (ppmb)	Max. Initial Enrichment $5.0$ wt.% $^{235}\text{U}$ (ppmb)	Max. Initial Enrichment $\leq 4.1$ wt.% $^{235}\text{U}$ (ppmb)	Max. Initial Enrichment $5.0$ wt.% $^{235}\text{U}$ (ppmb)
14x14A/B/C/D/	1,300	1,900	1,500	2,300
15x15A/B/C/G	1,800	2,500	1,900	2,700
15x15D/E/F/H	1,900	2,600	2,100	2,900
16x16A	1,300	1,900	1,500	2,300
17x17A/B/C	1,900	2,600	2,100	2,900

## Notes:

- For maximum initial enrichments between 4.1 wt% and 5.0 wt%  $^{235}\text{U}$ , the minimum soluble boron concentration may be determined by linear interpolation between the minimum soluble boron concentrations at 4.1 wt% and 5.1 wt%  $^{235}\text{U}$ .
- The soluble boron requirements for array/class 14x14E are specified in Supplement 2.II.



Table 2.1.17

## LIMITS FOR MATERIAL TO BE STORED IN MPC-24

PARAMETER	VALUE
Fuel Type	Uranium oxide, PWR intact fuel assemblies meeting the limits in Table 2.1.3 for the applicable array/class
Cladding Type	ZR or Stainless Steel (SS) as specified in Table 2.1.3 for the applicable array/class
Maximum Initial Enrichment per Assembly	As specified in Table 2.1.3 for the applicable array/class
Post-irradiation Cooling Time and Average Burnup per Assembly	ZR clad: As specified in Section 2.1.9.1 SS clad: $\geq 8$ years and $\leq 40,000$ MWD/MTU
Decay Heat Per Fuel Storage Location	ZR clad: As specified in Section 2.1.9.1 SS clad: $\leq 710$ Watts
Non-Fuel Hardware Burnup and Cooling Time	As specified in Table 2.1.25
Fuel Assembly Length	$\leq 176.8$ in. (nominal design)
Fuel Assembly Width	$\leq 8.54$ in. (nominal design)
Fuel Assembly Weight	$\leq 1,680$ lbs (including non-fuel hardware)
Other Limitations	<ul style="list-style-type: none"> <li>▪ Quantity is limited to up to 24 PWR intact fuel assemblies.</li> <li>▪ Damaged fuel assemblies and fuel debris are not permitted for storage in MPC-24.</li> <li>▪ One NSA is permitted in MPC-24.</li> <li>▪ BPRAs, TPDs, WABAs, water displacement guide tube plugs, orifice rod assemblies, and/or vibration suppressor inserts may be stored with fuel assemblies in any fuel cell location.</li> <li>▪ CRAs, RCCAs, CEAs, NSAs and/or APSRs may be stored with fuel assemblies in fuel cell locations 9, 10, 15, and/or 16</li> <li>▪ Soluble boron requirements during wet loading and unloading are specified in Table 2.1.14.</li> </ul>

Table 2.1.18

## LIMITS FOR MATERIAL TO BE STORED IN MPC-68

PARAMETER	VALUE (Note 1)			
Fuel Type(s)	Uranium oxide, BWR intact fuel assemblies meeting the limits in Table 2.1.4 for the applicable array/class, with or without channels	Uranium oxide, BWR damaged fuel assemblies meeting the limits in Table 2.1.4 for the applicable array/class, with or without channels, placed in Damaged Fuel Containers (DFCs)	Mixed Oxide (MOX) BWR intact fuel assemblies meeting the limits in Table 2.1.4 for array/class 6x6B, with or without channels	Mixed Oxide (MOX) BWR damaged fuel assemblies meeting the limits in Table 2.1.4 for array/class 6x6B, with or without channels, placed in Damaged Fuel Containers (DFCs)
Cladding Type	ZR or Stainless Steel (SS) as specified in Table 2.1.4 for the applicable array/class	ZR or Stainless Steel (SS) as specified in Table 2.1.4 for the applicable array/class	ZR	ZR
Maximum Initial Planar-Average Enrichment per Assembly and Rod Enrichment	As specified in Table 2.1.4 for the applicable array/class	Planar Average: $\leq 2.7$ wt% $^{235}\text{U}$ for array/classes 6x6A, 6x6C, 7x7A, and 8x8A; $\leq 4.0$ wt% $^{235}\text{U}$ for all other array/classes Rod: As specified in Table 2.1.4	As specified in Table 2.1.4 for array/class 6x6B	As specified in Table 2.1.4 for array/class 6x6B

Table 2.1.18 (cont'd)

## LIMITS FOR MATERIAL TO BE STORED IN MPC-68

PARAMETER	VALUE (Note 1)			
Post-irradiation Cooling Time and Average Burnup per Assembly	ZR clad: As specified in Section 2.1.9.1; except as provided in Notes 2 and 3.  SS clad: Note 4	ZR clad: As specified in Section 2.1.9.1; except as provided in Notes 2 and 3.  SS clad: Note 4.	Cooling time $\geq$ 18 years and average burnup $\leq$ 30,000 MWD/MTIHM.	Cooling time $\geq$ 18 years and average burnup $\leq$ 30,000 MWD/MTIHM.
Decay Heat Per Fuel Storage Location	ZR clad: As specified in Section 2.1.9.1; except as provided in Notes 2 and 3.  SS clad: $\leq$ 95 Watts	ZR clad: As specified in Section 2.1.9.1; except as provided in Notes 2 and 3.  SS clad: $\leq$ 95 Watts	$\leq$ 115 Watts	$\leq$ 115 Watts
Fuel Assembly Length	$\leq$ 176.5 in. (nominal design)	Array/classes 6x6A, 6x6C, 7x7A, and 8x8A: $\leq$ 135.0 in. (nominal design)  All Other array/classes: $\leq$ 176.5 in. (nominal design)	$\leq$ 135.0 in. (nominal design)	$\leq$ 135.0 in. (nominal design)
Fuel Assembly Width	$\leq$ 5.85 in. (nominal design)	Array/classes 6x6A, 6x6C, 7x7A, and 8x8A: $\leq$ 4.7 in. (nominal design)  All Other array/classes: $\leq$ 5.85 in. (nominal design)	$\leq$ 4.70 in. (nominal design)	$\leq$ 4.70 in. (nominal design)

Table 2.1.18 (cont'd)

LIMITS FOR MATERIAL TO BE STORED IN MPC-68

PARAMETER	VALUE (Note 1)			
Fuel Assembly Weight	$\leq 700$ lbs. (including channels)	Array/classes 6x6A, 6x6C, 7x7A, and 8x8A: $\leq 550$ lbs. (including channels and DFC)  All Other array/classes: $\leq 700$ lbs. (including channels and DFC)	$\leq 400$ lbs, including channels	$\leq 550$ lbs, including channels and DFC
Other Limitations	<ul style="list-style-type: none"> <li>▪ Quantity is limited to up to one (1) Dresden Unit 1 thoria rod canister meeting the specifications listed in Table 2.1.12 plus any combination of array/class 6x6A, 6x6B, 6x6C, 7x7A, and/or 8x8A damaged fuel assemblies in DFCs and intact fuel assemblies up to a total of 68.</li> <li>▪ Up to 16 damaged fuel assemblies from plants other than Dresden Unit 1 or Humboldt Bay may be stored in DFCs in fuel cell locations 1, 2, 3, 8, 9, 16, 25, 34, 35, 44, 53, 60, 61, 66, 67, and/or 68, with the balance comprised of intact fuel assemblies up to a total of 68</li> <li>▪ SS-clad fuel assemblies with stainless steel channels must be stored in fuel cell locations 19 through 22, 28 through 31, 38 through 41, and/or 47 through 50.</li> <li>▪ Dresden Unit 1 fuel assemblies with one antimony-beryllium neutron source are permitted. The antimony-beryllium neutron source material shall be in a water rod location.</li> <li>▪ Fuel debris is not permitted for storage in MPC-68.</li> </ul>			

Notes:

1. A fuel assembly must meet the requirements of any one column and the other limitations to be authorized for storage.
2. Array/class 6x6A, 6x6C, 7x7A, and 8x8A fuel assemblies shall have a cooling time  $\geq 18$  years, an average burnup  $\leq 30,000$  MWD/MTU, and a maximum decay heat  $\leq 115$  Watts.
3. Array/class 8x8F fuel assemblies shall have a cooling time  $\geq 10$  years, an average burnup  $\leq 27,500$  MWD/MTU, and a maximum decay  $\leq 183.5$  Watts.
4. SS-clad fuel assemblies shall have a cooling time  $\geq 10$  years, and an average burnup  $\leq 22,500$  MWD/MTU.

Table 2.1.19

## LIMITS FOR MATERIAL TO BE STORED IN MPC-68F

PARAMETER	VALUE (Notes 1 and 2)			
Fuel Type(s)	Uranium oxide, BWR intact fuel assemblies meeting the limits in Table 2.1.4 for array/class 6x6A, 6x6C, 7x7A, or 8x8A, with or without Zircaloy channels	Uranium oxide, BWR damaged fuel assemblies or fuel debris meeting the limits in Table 2.1.4 for array/class 6x6A, 6x6C, 7x7A, or 8x8A, with or without Zircaloy channels, placed in Damaged Fuel Containers (DFCs)	Mixed Oxide (MOX) BWR intact fuel assemblies meeting the limits in Table 2.1.4 for array/class 6x6B, with or without Zircaloy channels	Mixed Oxide (MOX) BWR damaged fuel assemblies or fuel debris meeting the limits in Table 2.1.4 for array/class 6x6B, with or without Zircaloy channels, placed in Damaged Fuel Containers (DFCs)
Cladding Type	ZR	ZR	ZR	ZR
Maximum Initial Planar-Average Enrichment per Assembly and Rod Enrichment	As specified in Table 2.1.4 for the applicable array/class	As specified in Table 2.1.4 for the applicable array/class	As specified in Table 2.1.4 for array/class 6x6B	As specified in Table 2.1.4 for array/class 6x6B
Post-irradiation Cooling Time, Average Burnup, and Minimum Initial Enrichment per Assembly	Cooling time $\geq$ 18 years and average burnup $\leq$ 30,000 MWD/MTU.	Cooling time $\geq$ 18 years and average burnup $\leq$ 30,000 MWD/MTU.	Cooling time $\geq$ 18 years and average burnup $\leq$ 30,000 MWD/MTIHM.	Cooling time $\geq$ 18 years and average burnup $\leq$ 30,000 MWD/MTIHM.
Decay Heat Per Fuel Storage Location	$\leq$ 115 Watts	$\leq$ 115 Watts	$\leq$ 115 Watts	$\leq$ 115 Watts
Fuel Assembly Length	$\leq$ 135.0 in. (nominal design)	$\leq$ 135.0 in. (nominal design)	$\leq$ 135.0 in. (nominal design)	$\leq$ 135.0 in. (nominal design)
Fuel Assembly Width	$\leq$ 4.70 in. (nominal design)	$\leq$ 4.70 in. (nominal design)	$\leq$ 4.70 in. (nominal design)	$\leq$ 4.70 in. (nominal design)
Fuel Assembly Weight	$\leq$ 400 lbs, (including channels)	$\leq$ 550 lbs, (including channels and DFC)	$\leq$ 400 lbs, (including channels)	$\leq$ 550 lbs, (including channels and DFC)

HOLTEC INTERNATIONAL COPYRIGHTED MATERIAL

Table 2.1.19 (cont'd)

LIMITS FOR MATERIAL TO BE STORED IN MPC-68F

PARAMETER	VALUE
Other Limitations	<ul style="list-style-type: none"> <li>▪ Quantity is limited to up to four (4) DFCs containing Dresden Unit 1 or Humboldt Bay uranium oxide or MOX fuel debris. The remaining fuel storage locations may be filled with array/class 6x6A, 6x6B, 6x6C, 7x7A, and 8x8A fuel assemblies of the following type, as applicable:               <ul style="list-style-type: none"> <li>- uranium oxide BWR intact fuel assemblies</li> <li>- MOX BWR intact fuel assemblies</li> <li>- uranium oxide BWR damaged fuel assemblies in DFCs</li> <li>- MOX BWR damaged fuel assemblies in DFCs</li> <li>- up to one (1) Dresden Unit 1 thoria rod canister meeting the specifications listed in Table 2.1.12.</li> </ul> </li> <li>▪ Stainless steel channels are not permitted.</li> <li>▪ Dresden Unit 1 fuel assemblies with one antimony-beryllium neutron source are permitted. The antimony-beryllium neutron source material shall be in a water rod location.</li> </ul>

Notes:

1. A fuel assembly must meet the requirements of any one column and the other limitations to be authorized for storage.
2. Only fuel from the Dresden Unit 1 and Humboldt Bay plants are permitted for storage in the MPC-68F.

Table 2.1.20

## LIMITS FOR MATERIAL TO BE STORED IN MPC-24E

PARAMETER	VALUE (Note 1)	
Fuel Type	Uranium oxide PWR intact fuel assemblies meeting the limits in Table 2.1.3 for the applicable array/class	Uranium oxide PWR damaged fuel assemblies meeting the limits in Table 2.1.3 for the applicable array/class, placed in a Damaged Fuel Container (DFC)
Cladding Type	ZR or Stainless Steel (SS) assemblies as specified in Table 2.1.3 for the applicable array/class	ZR or Stainless Steel (SS) assemblies as specified in Table 2.1.3 for the applicable array/class
Maximum Initial Enrichment per Assembly	As specified in Table 2.1.3 for the applicable array/class	As specified in Table 2.1.3 for the applicable array/class
Post-irradiation Cooling Time, and Average Burnup per Assembly	ZR clad: As specified in Section 2.1.9.1  SS clad: $\geq 8$ yrs and $\leq 40,000$ MWD/MTU	ZR clad: As specified in Section 2.1.9.1  SS clad: $\geq 8$ yrs and $\leq 40,000$ MWD/MTU
Decay Heat Per Fuel Storage Location	ZR clad: As specified in Section 2.1.9.1  SS clad: $\leq 710$ Watts	ZR clad: As specified in Section 2.1.9.1  SS clad: $\leq 710$ Watts
Non-fuel hardware post-irradiation Cooling Time and Burnup	As specified in Table 2.1.25	As specified in Table 2.1.25
Fuel Assembly Length	$\leq 176.8$ in. (nominal design)	$\leq 176.8$ in. (nominal design)
Fuel Assembly Width	$\leq 8.54$ in. (nominal design)	$\leq 8.54$ in. (nominal design)
Fuel Assembly Weight	$\leq 1680$ lbs (including non-fuel hardware)	$\leq 1680$ lbs (including DFC and non-fuel hardware)

Table 2.1.20 (cont'd)

LIMITS FOR MATERIAL TO BE STORED IN MPC-24E

PARAMETER	VALUE
Other Limitations	<ul style="list-style-type: none"> <li>▪ Quantity is limited to up to 24 PWR intact fuel assemblies or up to four (4) damaged fuel assemblies in DFCs may be stored in fuel storage locations 3, 6, 19, and/or 22. The remaining fuel storage locations may be filled with intact fuel assemblies.</li> <li>▪ Fuel debris is not authorized for storage in the MPC-24E.</li> <li>▪ One NSA is permitted in MPC-24E.</li> <li>▪ BPRAs, TPDs, WABAs, water displacement guide tube plugs, orifice rod assemblies, and/or vibration suppressor inserts may be stored with fuel assemblies in any fuel cell location.</li> <li>▪ CRAs, RCCAs, CEAs, NSAs, and/or APSRs may be stored with fuel assemblies in fuel cell locations 9, 10, 15, and/or 16.</li> <li>▪ Soluble boron requirements during wet loading and unloading are specified in Table 2.1.14.</li> </ul>

Notes:

1. A fuel assembly must meet the requirements of any one column and the other limitations to be authorized for storage.



Table 2.1.21

## LIMITS FOR MATERIAL TO BE STORED IN MPC-32

PARAMETER	VALUE (Notes 1 and 2)	
Fuel Type	Uranium oxide, PWR intact fuel assemblies meeting the limits in Table 2.1.3 for the applicable fuel assembly array/class.	Uranium oxide, PWR damaged fuel assemblies meeting the limits in Table 2.1.3 for the applicable fuel assembly array/class.
Cladding Type	ZR or Stainless Steel (SS) assemblies as specified in Table 2.1.3 for the applicable array/class	ZR or Stainless Steel (SS) assemblies as specified in Table 2.1.3 for the applicable array/class
Maximum Initial Enrichment per Assembly	As specified in Table 2.1.3 for the applicable fuel assembly array/class	As specified in Table 2.1.3 for the applicable fuel assembly array/class
Post-irradiation Cooling Time and Average Burnup per Assembly	ZR clad: As specified in Section 2.1.9.1  SS clad: $\geq 9$ years and $\leq 30,000$ MWD/MTU or $\geq 20$ years and $\leq 40,000$ MWD/MTU	ZR clad: As specified in Section 2.1.9.1  SS clad: $\geq 9$ years and $\leq 30,000$ MWD/MTU or $\geq 20$ years and $\leq 40,000$ MWD/MTU
Decay Heat Per Fuel Storage Location	ZR-clad: As specified in Section 2.1.9.1  SS-clad: $\leq 500$ Watts	ZR-clad: As specified in Section 2.1.9.1  SS-clad: $\leq 500$ Watts
Non-fuel hardware post-irradiation cooling time and burnup	As specified in Table 2.1.25	As specified in Table 2.1.25
Fuel Assembly Length	$\leq 176.8$ in. (nominal design)	$\leq 176.8$ in. (nominal design)
Fuel Assembly Width	$\leq 8.54$ in. (nominal design)	$\leq 8.54$ in. (nominal design)
Fuel Assembly Weight	$\leq 1,680$ lbs (including non-fuel hardware)	$\leq 1,680$ lbs (including DFC and non-fuel hardware)

Table 2.1.21 (cont'd)

LIMITS FOR MATERIAL TO BE STORED IN MPC-32

PARAMETER	VALUE
Other Limits	<ul style="list-style-type: none"> <li>▪ Quantity is limited to up to 32 PWR intact fuel assemblies and/or up to eight (8) damaged fuel assemblies in DFCs in fuel cell locations 1, 4, 5, 10, 23, 28, 29, and/or 32, with the balance intact fuel assemblies up to a total of 32.</li> <li>▪ Fuel debris is not permitted for storage in MPC-32.</li> <li>▪ One NSA is permitted in MPC-32.</li> <li>▪ BPRAs, TPDs, WABAs, water displacement guide tube plugs, orifice rod assemblies, and/or vibration suppressor inserts may be stored with fuel assemblies in any fuel cell location.</li> <li>▪ CRAs, RCCAs, CEAs, NSAs, and/or APSRs may be stored with fuel assemblies in fuel cell locations 13, 14, 19, and/or 20.</li> <li>▪ Soluble boron requirements during wet loading and unloading are specified in Table 2.1.16.</li> </ul>

NOTES:

1. A fuel assembly must meet the requirements of any one column and the other limitations to be authorized for storage.
2. The requirements stated in this table, with the exception of fuel assembly length, width, and weight, do not apply to array/class 14x14E, Indian Point Unit 1 fuel. Supplement 2.II provides the limits for array/class 14x14E fuel assemblies to be stored in the MPC-32.

Table 2.1.22

## LIMITS FOR MATERIAL TO BE STORED IN MPC-68FF

PARAMETER	VALUE (Note 1)	
Fuel Type	Uranium oxide or MOX BWR intact fuel assemblies meeting the limits in Table 2.1.4 for the applicable array/class, with or without channels.	Uranium oxide or MOX BWR damaged fuel assemblies or fuel debris meeting the limits in Table 2.1.4 for the applicable array/class, with or without channels, in DFCs.
Cladding Type	ZR or Stainless Steel (SS) assemblies as specified in Table 2.1.4 for the applicable array/class	ZR or Stainless Steel (SS) assemblies as specified in Table 2.1.4 for the applicable array/class
Maximum Initial Planar Average Enrichment per Assembly and Rod Enrichment	As specified in Table 2.1.4 for the applicable fuel assembly array/class	Planar Average: $\leq 2.7 \text{ wt}\% \text{ }^{235}\text{U}$ for array/classes 6x6A, 6x6B, 6x6C, 7x7A, and 8x8A; $\leq 4.0 \text{ wt}\% \text{ }^{235}\text{U}$ for all other array/classes Rod: As specified in Table 2.1.4
Post-irradiation cooling time and average burnup per Assembly	ZR clad: As specified in Section 2.1.9.1; except as provided in Notes 2 and 3. SS clad: Note 4	ZR clad: As specified in Section 2.1.9.1; except as provided in Notes 2 and 3. SS clad: Note 4.
Decay Heat Per Fuel Storage Location	ZR clad: As specified in Section 2.1.9.1; except as provided in Notes 2 and 3. SS clad: $\leq 95$ Watts	ZR clad: As specified in Section 2.1.9.1; except as provided in Notes 2 and 3. SS clad: $\leq 95$ Watts
Fuel Assembly Length	Array/classes 6x6A, 6x6B, 6x6C, 7x7A, and 8x8A: $\leq 135.0$ in. (nominal design) All Other array/classes: $\leq 176.5$ in. (nominal design)	Array/classes 6x6A, 6x6B, 6x6C, 7x7A, and 8x8A: $\leq 135.0$ in. (nominal design) All Other array/classes: $\leq 176.5$ in. (nominal design)

Table 2.1.22 (cont'd)

LIMITS FOR MATERIAL TO BE STORED IN MPC-68FF

PARAMETER	VALUE (Note 1)	
Fuel Assembly Width	Array/classes 6x6A, 6x6B, 6x6C, 7x7A, and 8x8A: $\leq 4.7$ in. (nominal design)  All Other array/classes: $\leq 5.85$ in. (nominal design)	Array/classes 6x6A, 6x6B, 6x6C, 7x7A, and 8x8A: $\leq 4.7$ in. (nominal design)  All Other array/classes: $\leq 5.85$ in. (nominal design)
Fuel Assembly Weight	Array/classes 6x6A, 6x6B, 6x6C, 7x7A, and 8x8A: $\leq 550$ lbs. (including channels)  All Other array/classes: $\leq 700$ lbs. (including channels)	Array/classes 6x6A, 6x6B, 6x6C, 7x7A, and 8x8A: $\leq 550$ lbs. (including channels and DFC)  All Other array/classes: $\leq 700$ lbs. (including channels and DFC)
Other Limitations	<ul style="list-style-type: none"> <li>▪ Quantity is limited to up to one (1) Up to eight (8) Dresden Unit 1 or Humboldt Bay fuel assemblies classified as fuel debris in DFCs, and any combination of Dresden Unit 1 or Humboldt Bay damaged fuel assemblies in DFCs and intact fuel assemblies up to a total of 68.</li> <li>▪ Up to 16 damaged fuel assemblies and/or up to eight (8) fuel assemblies classified as fuel debris from plants other than Dresden Unit 1 or Humboldt Bay may be stored in DFCs in MPC-68FF. DFCs shall be located only in fuel cell locations 1, 2, 3, 8, 9, 16, 25, 34, 35, 44, 53, 60, 61, 66, 67, and/or 68, with the balance comprised of intact fuel assemblies meeting the above specifications, up to a total of 68.</li> <li>▪ SS-clad fuel assemblies with stainless steel channels must be stored in fuel cell locations 19 through 22, 28 through 31, 38 through 41, and/or 47 through 50.</li> <li>▪ Dresden Unit 1 fuel assemblies with one antimony-beryllium neutron source are permitted. The antimony-beryllium neutron source material shall be in a water rod location.</li> </ul>	

NOTES:

1. A fuel assembly must meet the requirements of any one column and the other limitations to be authorized for storage.
2. Array/class 6x6A, 6x6B, 6x6C, 7x7A, and 8x8A fuel assemblies shall have a cooling time  $\geq 18$  years, an average burnup  $\leq 30,000$  MWD/MTU, and a maximum decay heat  $\leq 115$  Watts.
3. Array/class 8x8F fuel assemblies shall have a cooling time  $\geq 10$  years, an average burnup  $\leq 27,500$  MWD/MTU, and a maximum decay  $\leq 183.5$  Watts.
4. SS-clad fuel assemblies shall have a cooling time  $\geq 10$  years, and an average burnup  $\leq 22,500$  MWD/MTU.

Table 2.1.23

## LIMITS FOR MATERIAL TO BE STORED IN MPC-24EF

PARAMETER	VALUE (Note 1)	
Fuel Type	Uranium oxide PWR intact fuel assemblies meeting the limits in Table 2.1.3 for the applicable array/class	Uranium oxide PWR damaged fuel assemblies and/or fuel debris meeting the limits in Table 2.1.3 for the applicable array/class, placed in a Damaged Fuel Container (DFC)
Cladding Type	ZR or Stainless Steel (SS) assemblies as specified in Table 2.1.3 for the applicable array/class	ZR or Stainless Steel (SS) assemblies as specified in Table 2.1.3 for the applicable array/class
Maximum Initial Enrichment per Assembly	As specified in Table 2.1.3 for the applicable array/class	As specified in Table 2.1.3 for the applicable array/class
Post-irradiation Cooling Time, and Average Burnup per Assembly	ZR clad: As specified in Section 2.1.9.1  SS clad: $\geq 8$ yrs and $\leq 40,000$ MWD/MTU	ZR clad: As specified in Section 2.1.9.1  SS clad: $\geq 8$ yrs and $\leq 40,000$ MWD/MTU
Decay Heat Per Fuel Storage Location	ZR clad: As specified in Section 2.1.9.1  SS clad: $\leq 710$ Watts	ZR clad: As specified in Section 2.1.9.1  SS clad: $\leq 710$ Watts
Non-fuel hardware post-irradiation Cooling Time and Burnup	As specified in Table 2.1.25	As specified in Table 2.1.25
Fuel Assembly Length	$\leq 176.8$ in. (nominal design)	$\leq 176.8$ in. (nominal design)
Fuel Assembly Width	$\leq 8.54$ in. (nominal design)	$\leq 8.54$ in. (nominal design)
Fuel Assembly Weight	$\leq 1680$ lbs (including non-fuel hardware)	$\leq 1680$ lbs (including DFC and non-fuel hardware)

Table 2.1.23 (cont'd)

LIMITS FOR MATERIAL TO BE STORED IN MPC-24EF

PARAMETER	VALUE
Other Limitations	<ul style="list-style-type: none"> <li>▪ Quantity per MPC: up to 24 PWR intact fuel assemblies or up to four (4) damaged fuel assemblies and/or fuel classified as fuel debris in DFCs may be stored in fuel storage locations 3, 6, 19, and/or 22. The remaining fuel storage locations may be filled with intact fuel assemblies.</li> <li>▪ One NSA is authorized for storage in the MPC-24EF.</li> <li>▪ BPRAs, TPDs, WABAs, water displacement guide tube plugs, orifice rod assemblies, and/or vibration suppressor inserts may be stored with fuel assemblies in any fuel cell location.</li> <li>▪ CRAs, RCCAs, CEAs, NSAs, and/or APSRs may be stored with fuel assemblies in fuel cell locations 9, 10, 15, and/or 16.</li> <li>▪ Soluble boron requirements during wet loading and unloading are specified in Table 2.1.14.</li> </ul>

Notes:

1. A fuel assembly must meet the requirements of any one column and the other limitations to be authorized for storage.

Table 2.1.24

## LIMITS FOR MATERIAL TO BE STORED IN MPC-32F

PARAMETER	VALUE (Notes 1 and 2)	
Fuel Type	Uranium oxide, PWR intact fuel assemblies meeting the limits in Table 2.1.3 for the applicable fuel assembly array/class	Uranium oxide, PWR damaged fuel assemblies and fuel debris in DFCs meeting the limits in Table 2.1.3 for the applicable fuel assembly array/class
Cladding Type	ZR or Stainless Steel (SS) as specified in Table 2.1.3 for the applicable fuel assembly array/class	ZR or Stainless Steel (SS) as specified in Table 2.1.3 for the applicable fuel assembly array/class
Maximum Initial Enrichment per Assembly	As specified in Table 2.1.3	As specified in Table 2.1.3
Post-irradiation Cooling Time, Average Burnup, and Minimum Initial Enrichment per Assembly	ZR clad: As specified in Section 2.1.9.1  SS clad: $\geq 9$ years and $\leq 30,000$ MWD/MTU or $\geq 20$ years and $\leq 40,000$ MWD/MTU	ZR clad: As specified in Section 2.1.9.1  SS clad: $\geq 9$ years and $\leq 30,000$ MWD/MTU or $\geq 20$ years and $\leq 40,000$ MWD/MTU
Decay Heat Per Fuel Storage Location	ZR clad: As specified in Section 2.1.9.1  SS clad: $\leq 500$ Watts	ZR clad: As specified in Section 2.1.9.1  SS clad: $\leq 500$ Watts
Non-fuel hardware post-irradiation Cooling Time and Burnup	As specified in Table 2.1.25	As specified in Table 2.1.25
Fuel Assembly Length	$\leq 176.8$ in. (nominal design)	$\leq 176.8$ in. (nominal design)
Fuel Assembly Width	$\leq 8.54$ in. (nominal design)	$\leq 8.54$ in. (nominal design)
Fuel Assembly Weight	$\leq 1,680$ lbs (including non-fuel hardware)	$\leq 1,680$ lbs (including DFC and non-fuel hardware)

Table 2.1.24 (cont'd)

LIMITS FOR MATERIAL TO BE STORED IN MPC-32F

PARAMETER	VALUE
<i>Other Limitations</i>	<ul style="list-style-type: none"> <li>▪ Quantity is limited to up to 32 PWR intact fuel assemblies and/or up to eight (8) damaged fuel assemblies in DFCs in fuel cell locations 1, 4, 5, 10, 23, 28, 29, and/or 32, with the balance intact fuel assemblies up to a total of 32.</li> <li>▪ One NSA is permitted for storage in MPC-32.</li> <li>▪ BPRAs, TPDs, WABAs, water displacement guide tube plugs, orifice rod assemblies, and/or vibration suppressor inserts may be stored with fuel assemblies in any fuel cell location.</li> <li>▪ CRAs, RCCAs, CEAs, NSAs, and/or APSRs may be stored with fuel assemblies in fuel cell locations 13, 14, 19, and/or 20.</li> <li>▪ Soluble boron requirements during wet loading and unloading are specified in Table 2.1.16.</li> </ul>

NOTES:

1. A fuel assembly must meet the requirements of any one column and the other limitations to be authorized for storage.
2. *The requirements stated in this table, with the exception of fuel assembly length, width, and weight, do not apply to array/class 14x14E, Indian Point Unit 1 fuel. Supplement 2.II provides the limits for array/class 14x14E fuel assemblies to be stored in the MPC-32F.*



Table 2.1.25

## NON-FUEL HARDWARE BURNUP AND COOLING TIME LIMITS (Notes 1, 2, and 3)

Post-irradiation Cooling Time (yrs)	Inserts (Note 4) Maximum Burnup (MWD/MTU)	NSA or Guide Tube Hardware (Note 5) Maximum Burnup (MWD/MTU)	Control Component (Note 6) Maximum Burnup (MWD/MTU)	APSR Maximum Burnup (MWD/MTU)
≥ 3	≤ 24,635	N/A (Note 7)	N/A	N/A
≥ 4	≤ 30,000	≤ 20,000	N/A	N/A
≥ 5	≤ 36,748	≤ 25,000	≤ 630,000	≤ 45,000
≥ 6	≤ 44,102	≤ 30,000	-	≤ 54,500
≥ 7	≤ 52,900	≤ 40,000	-	≤ 68,000
≥ 8	≤ 60,000	≤ 45,000	-	≤ 83,000
≥ 9	-	≤ 50,000	-	≤ 111,000
≥ 10	-	≤ 60,000	-	≤ 180,000
≥ 11	-	≤ 75,000	-	≤ 630,000
≥ 12	-	≤ 90,000	-	-
≥ 13	-	≤ 180,000	-	-
≥ 14	-	≤ 630,000	-	-

## NOTES:

- Burnups for non-fuel hardware are to be determined based on the burnup and uranium mass of the fuel assemblies in which the component was inserted during reactor operation.
- Linear interpolation between points is permitted, except that NSA or Guide Tube Hardware and APSR burnups > 180,000 MWD/MTU and ≤ 630,000 MWD/MTU must be cooled ≥ 14 years and ≥ 11 years, respectively.
- Applicable to uniform loading and regionalized loading.
- Includes Burnable Poison Rod Assemblies (BPRAs), Wet Annular Burnable Absorbers (WABAs), and vibration suppressor inserts.
- Includes Thimble Plug Devices (TPDs), water displacement guide tube plugs, and orifice rod assemblies.
- Includes Control Rod Assemblies (CRAs), Control Element Assemblies (CEAs), and Rod Cluster Control Assemblies (RCCAs).
- N/A means not authorized for loading at this cooling time.

Table 2.1.26

MAXIMUM ALLOWABLE DECAY HEAT PER FUEL STORAGE LOCATION  
(UNIFORM LOADING, ZR-CLAD)

MPC Model	Decay Heat per Fuel Assembly (kW)
Intact Fuel Assemblies	
MPC-24	$\leq 1.157$
MPC-24E/24EF	$\leq 1.173$
MPC-32/32F	$\leq 0.898$
MPC-68/68FF	$\leq 0.414$
Damaged Fuel Assemblies and Fuel Debris	
MPC-24	$\leq 1.099$
MPC-24E/24EF	$\leq 1.114$
MPC-32/32F	$\leq 0.718$
MPC-68/68FF	$\leq 0.393$

Table 2.1.27

## MPC FUEL STORAGE REGIONS AND MAXIMUM DECAY HEAT

<b>MPC Model</b>	<b>Number of Fuel Storage Locations in Inner and Outer Regions</b>	<b>Inner Region Maximum Decay Heat per Assembly (kW)</b>	<b>Outer Region Maximum Decay Heat per Assembly (kW)</b>
MPC-24	4 and 20	1.470	0.900
MPC-24E/24EF	4 and 20	1.540	0.900
MPC-32/32F	12 and 20	1.131	0.600
MPC-68/68FF	32 and 36	0.500	0.275

Note: These limits apply to intact fuel assemblies, damaged fuel assemblies and fuel debris.

Table 2.1.28

PWR FUEL ASSEMBLY COOLING TIME-DEPENDENT COEFFICIENTS  
(ZR-CLAD FUEL)

Cooling Time (years)	Array/Class 14x14A						
	A	B	C	D	E	F	G
≥ 3	20277.1	303.592	-68.329	-139.41	2993.67	-498.159	-615.411
≥ 4	35560.1	-6034.67	985.415	-132.734	3578.92	-723.721	-609.84
≥ 5	48917.9	-14499.5	2976.09	-150.707	4072.55	-892.691	-54.8362
≥ 6	59110.3	-22507	5255.61	-177.017	4517.03	-1024.01	613.36
≥ 7	67595.6	-30158.1	7746.6	-200.128	4898.71	-1123.21	716.004
≥ 8	74424.9	-36871.1	10169.4	-218.676	5203.64	-1190.24	741.163
≥ 9	81405.8	-44093.1	12910.8	-227.916	5405.34	-1223.27	250.224
≥ 10	86184.3	-49211.7	15063.4	-237.641	5607.96	-1266.21	134.435
≥ 11	92024.9	-55666.8	17779.6	-240.973	5732.25	-1282.12	-401.456
≥ 12	94775.8	-58559.7	19249.9	-246.369	5896.27	-1345.42	-295.435
≥ 13	100163	-64813.8	22045.1	-242.572	5861.86	-1261.66	-842.159
≥ 14	103971	-69171	24207	-242.651	5933.96	-1277.48	-1108.99
≥ 15	108919	-75171.1	27152.4	-243.154	6000.2	-1301.19	-1620.63
≥ 16	110622	-76715.2	28210.2	-240.235	6028.33	-1307.74	-1425.5
≥ 17	115582	-82929.7	31411.9	-235.234	5982.3	-1244.11	-1948.05
≥ 18	119195	-87323.5	33881.4	-233.28	6002.43	-1245.95	-2199.41
≥ 19	121882	-90270.6	35713.7	-231.873	6044.42	-1284.55	-2264.05
≥ 20	124649	-93573.5	37853.1	-230.22	6075.82	-1306.57	-2319.63

Table 2.1.28 (cont'd)

PWR FUEL ASSEMBLY COOLING TIME-DEPENDENT COEFFICIENTS  
(ZR-CLAD FUEL)

Cooling Time (years)	Array/Class 14x14B						
	A	B	C	D	E	F	G
≥ 3	18937.9	70.2997	-28.6224	-130.732	2572.36	-383.393	-858.17
≥ 4	32058.7	-4960.63	745.224	-125.978	3048.98	-551.656	-549.108
≥ 5	42626.3	-10804.1	1965.09	-139.722	3433.49	-676.643	321.88
≥ 6	51209.6	-16782.3	3490.45	-158.929	3751.01	-761.524	847.282
≥ 7	57829.9	-21982	5009.12	-180.026	4066.65	-846.272	1200.45
≥ 8	62758	-26055.3	6330.88	-196.804	4340.18	-928.336	1413.17
≥ 9	68161.4	-30827.6	7943.87	-204.454	4500.52	-966.347	1084.69
≥ 10	71996.8	-34224.3	9197.25	-210.433	4638.94	-1001.83	1016.38
≥ 11	75567.3	-37486.1	10466.9	-214.95	4759.55	-1040.85	848.169
≥ 12	79296.7	-40900.3	11799.6	-212.898	4794.13	-1040.51	576.242
≥ 13	82257.3	-43594	12935	-212.8	4845.81	-1056.01	410.807
≥ 14	83941.2	-44915.2	13641	-215.389	4953.19	-1121.71	552.724
≥ 15	87228.5	-48130	15056.9	-212.545	4951.12	-1112.5	260.194
≥ 16	90321.7	-50918.3	16285.5	-206.094	4923.36	-1106.35	-38.7487
≥ 17	92836.2	-53314.5	17481.7	-203.139	4924.61	-1109.32	-159.673
≥ 18	93872.8	-53721.4	17865.1	-202.573	4956.21	-1136.9	30.0594
≥ 19	96361.6	-56019.1	19075.9	-199.068	4954.59	-1156.07	-125.917
≥ 20	98647.5	-57795.1	19961.8	-191.502	4869.59	-1108.74	-217.603

Table 2.1.28 (cont'd)

PWR FUEL ASSEMBLY COOLING TIME-DEPENDENT COEFFICIENTS  
(ZR-CLAD FUEL)

Cooling Time (years)	Array/Class 14x14C						
	A	B	C	D	E	F	G
≥ 3	19176.9	192.012	-66.7595	-138.112	2666.73	-407.664	-1372.41
≥ 4	32040.3	-4731.4	651.014	-124.944	3012.63	-530.456	-890.059
≥ 5	43276.7	-11292.8	2009.76	-142.172	3313.91	-594.917	-200.195
≥ 6	51315.5	-16920.5	3414.76	-164.287	3610.77	-652.118	463.041
≥ 7	57594.7	-21897.6	4848.49	-189.606	3940.67	-729.367	781.46
≥ 8	63252.3	-26562.8	6273.01	-199.974	4088.41	-732.054	693.879
≥ 9	67657.5	-30350.9	7533.4	-211.77	4283.39	-772.916	588.456
≥ 10	71834.4	-34113.7	8857.32	-216.408	4383.45	-774.982	380.243
≥ 11	75464.1	-37382.1	10063	-218.813	4460.69	-776.665	160.668
≥ 12	77811.1	-39425.1	10934.3	-225.193	4604.68	-833.459	182.463
≥ 13	81438.3	-42785.4	12239.9	-220.943	4597.28	-803.32	-191.636
≥ 14	84222.1	-45291.6	13287.9	-218.366	4608.13	-791.655	-354.59
≥ 15	86700.1	-47582.6	14331.2	-218.206	4655.34	-807.366	-487.316
≥ 16	88104.7	-48601.1	14927.9	-219.498	4729.97	-849.446	-373.196
≥ 17	91103.3	-51332.5	16129	-212.138	4679.91	-822.896	-654.296
≥ 18	93850.4	-53915.8	17336.9	-207.666	4652.65	-799.697	-866.307
≥ 19	96192.9	-55955.8	18359.3	-203.462	4642.65	-800.315	-1007.75
≥ 20	97790.4	-57058.1	19027.7	-200.963	4635.88	-799.721	-951.122

Table 2.1.28 (cont'd)

PWR FUEL ASSEMBLY COOLING TIME-DEPENDENT COEFFICIENTS  
(ZR-CLAD FUEL)

Cooling Time (years)	Array/Class 15x15A/B/C						
	A	B	C	D	E	F	G
≥ 3	15789.2	119.829	-21.8071	-127.422	2152.53	-267.717	-580.768
≥ 4	26803.8	-3312.93	415.027	-116.279	2550.15	-386.33	-367.168
≥ 5	36403.6	-7831.93	1219.66	-126.065	2858.32	-471.785	326.863
≥ 6	44046.1	-12375.9	2213.52	-145.727	3153.45	-539.715	851.971
≥ 7	49753.5	-16172.6	3163.61	-166.946	3428.38	-603.598	1186.31
≥ 8	55095.4	-20182.5	4287.03	-183.047	3650.42	-652.92	1052.4
≥ 9	58974.4	-23071.6	5156.53	-191.718	3805.41	-687.18	1025
≥ 10	62591.8	-25800.8	5995.95	-195.105	3884.14	-690.659	868.556
≥ 11	65133.1	-27747.4	6689	-203.095	4036.91	-744.034	894.607
≥ 12	68448.4	-30456	7624.9	-202.201	4083.52	-753.391	577.914
≥ 13	71084.4	-32536.4	8381.78	-201.624	4117.93	-757.16	379.105
≥ 14	73459.5	-34352.3	9068.86	-197.988	4113.16	-747.015	266.536
≥ 15	75950.7	-36469.4	9920.52	-199.791	4184.91	-779.222	57.9429
≥ 16	76929.1	-36845.6	10171.3	-197.88	4206.24	-794.541	256.099
≥ 17	79730	-39134.8	11069.4	-190.865	4160.42	-773.448	-42.6853
≥ 18	81649.2	-40583	11736.1	-187.604	4163.36	-785.838	-113.614
≥ 19	83459	-41771.8	12265.9	-181.461	4107.51	-758.496	-193.442
≥ 20	86165.4	-44208.8	13361.2	-178.89	4107.62	-768.671	-479.778

Table 2.1.28 (cont'd)

PWR FUEL ASSEMBLY COOLING TIME-DEPENDENT COEFFICIENTS  
(ZR-CLAD FUEL)

Cooling Time (years)	Array/Class 15x15D/E/F/H						
	A	B	C	D	E	F	G
≥ 3	15192.5	50.5722	-12.3042	-126.906	2009.71	-235.879	-561.574
≥ 4	25782.5	-3096.5	369.096	-113.289	2357.75	-334.695	-254.964
≥ 5	35026.5	-7299.87	1091.93	-124.619	2664	-414.527	470.916
≥ 6	42234.9	-11438.4	1967.63	-145.948	2945.81	-474.981	1016.84
≥ 7	47818.4	-15047	2839.22	-167.273	3208.95	-531.296	1321.12
≥ 8	52730.7	-18387.2	3702.43	-175.057	3335.58	-543.232	1223.61
≥ 9	56254.6	-20999.9	4485.93	-190.489	3547.98	-600.64	1261.55
≥ 10	59874.6	-23706.5	5303.88	-193.807	3633.01	-611.892	1028.63
≥ 11	62811	-25848.4	5979.64	-194.997	3694.14	-618.968	862.738
≥ 12	65557.6	-27952.4	6686.74	-198.224	3767.28	-635.126	645.139
≥ 13	67379.4	-29239.2	7197.49	-200.164	3858.53	-677.958	652.601
≥ 14	69599.2	-30823.8	7768.51	-196.788	3868.2	-679.88	504.443
≥ 15	71806.7	-32425	8360.38	-191.935	3851.65	-669.917	321.146
≥ 16	73662.6	-33703.5	8870.78	-187.366	3831.59	-658.419	232.335
≥ 17	76219.8	-35898.1	9754.72	-189.111	3892.07	-694.244	-46.924
≥ 18	76594.4	-35518.2	9719.78	-185.11	3897.04	-712.82	236.047
≥ 19	78592.7	-36920.8	10316.5	-179.54	3865.84	-709.551	82.478
≥ 20	80770.5	-38599.9	11051.3	-175.106	3858.67	-723.211	-116.014



Table 2.1.28 (cont'd)

PWR FUEL ASSEMBLY COOLING TIME-DEPENDENT COEFFICIENTS  
(ZR-CLAD FUEL)

Cooling Time (years)	Array/Class 16x16A						
	A	B	C	D	E	F	G
≥ 3	17038.2	158.445	-37.6008	-136.707	2368.1	-321.58	-700.033
≥ 4	29166.3	-3919.95	508.439	-125.131	2782.53	-455.722	-344.199
≥ 5	40285	-9762.36	1629.72	-139.652	3111.83	-539.804	139.67
≥ 6	48335.7	-15002.6	2864.09	-164.702	3444.97	-614.756	851.706
≥ 7	55274.9	-20190	4258.03	-185.909	3728.11	-670.841	920.035
≥ 8	60646.6	-24402.4	5483.54	-199.014	3903.29	-682.26	944.913
≥ 9	64663.2	-27753.1	6588.21	-215.318	4145.34	-746.822	967.914
≥ 10	69306.9	-31739.1	7892.13	-218.898	4237.04	-746.815	589.277
≥ 11	72725.8	-34676.6	8942.26	-220.836	4312.93	-750.85	407.133
≥ 12	76573.8	-38238.7	10248.1	-224.934	4395.85	-757.914	23.7549
≥ 13	78569	-39794.3	10914.9	-224.584	4457	-776.876	69.428
≥ 14	81559.4	-42453.6	11969.6	-222.704	4485.28	-778.427	-203.031
≥ 15	84108.6	-44680.4	12897.8	-218.387	4460	-746.756	-329.078
≥ 16	86512.2	-46766.8	13822.8	-216.278	4487.79	-759.882	-479.729
≥ 17	87526.7	-47326.2	14221	-218.894	4567.68	-805.659	-273.692
≥ 18	90340.3	-49888.6	15349.8	-212.139	4506.29	-762.236	-513.316
≥ 19	93218.2	-52436.7	16482.4	-207.653	4504.12	-776.489	-837.1
≥ 20	95533.9	-54474.1	17484.2	-203.094	4476.21	-760.482	-955.662

Table 2.1.28 (cont'd)

PWR FUEL ASSEMBLY COOLING TIME-DEPENDENT COEFFICIENTS  
(ZR-CLAD FUEL)

Cooling Time (years)	Array/Class 17x17A						
	A	B	C	D	E	F	G
≥ 3	16784.4	3.90244	-10.476	-128.835	2256.98	-287.108	-263.081
≥ 4	28859	-3824.72	491.016	-120.108	2737.65	-432.361	-113.457
≥ 5	40315.9	-9724	1622.89	-140.459	3170.28	-547.749	425.136
≥ 6	49378.5	-15653.1	3029.25	-164.712	3532.55	-628.93	842.73
≥ 7	56759.5	-21320.4	4598.78	-190.58	3873.21	-698.143	975.46
≥ 8	63153.4	-26463.8	6102.47	-201.262	4021.84	-685.431	848.497
≥ 9	67874.9	-30519.2	7442.84	-218.184	4287.23	-754.597	723.305
≥ 10	72676.8	-34855.2	8928.27	-222.423	4382.07	-741.243	387.877
≥ 11	75623	-37457.1	9927.65	-232.962	4564.55	-792.051	388.402
≥ 12	80141.8	-41736.5	11509.8	-232.944	4624.72	-787.134	-164.727
≥ 13	83587.5	-45016.4	12800.9	-230.643	4623.2	-745.177	-428.635
≥ 14	86311.3	-47443.4	13815.2	-228.162	4638.89	-729.425	-561.758
≥ 15	87839.2	-48704.1	14500.3	-231.979	4747.67	-775.801	-441.959
≥ 16	91190.5	-51877.4	15813.2	-225.768	4692.45	-719.311	-756.537
≥ 17	94512	-55201.2	17306.1	-224.328	4740.86	-747.11	-1129.15
≥ 18	96959	-57459.9	18403.8	-220.038	4721.02	-726.928	-1272.47
≥ 19	99061.1	-59172.1	19253.1	-214.045	4663.37	-679.362	-1309.88
≥ 20	100305	-59997.5	19841.1	-216.112	4721.71	-705.463	-1148.45

Table 2.1.28 (cont'd)

PWR FUEL ASSEMBLY COOLING TIME-DEPENDENT COEFFICIENTS  
(ZR-CLAD FUEL)

Cooling Time (years)	Array/Class 17x17B/C						
	A	B	C	D	E	F	G
≥ 3	15526.8	18.0364	-9.36581	-128.415	2050.81	-243.915	-426.07
≥ 4	26595.4	-3345.47	409.264	-115.394	2429.48	-350.883	-243.477
≥ 5	36190.4	-7783.2	1186.37	-130.008	2769.53	-438.716	519.95
≥ 6	44159	-12517.5	2209.54	-150.234	3042.25	-489.858	924.151
≥ 7	50399.6	-16780.6	3277.26	-173.223	3336.58	-555.743	1129.66
≥ 8	55453.9	-20420	4259.68	-189.355	3531.65	-581.917	1105.62
≥ 9	59469.3	-23459.8	5176.62	-199.63	3709.99	-626.667	1028.74
≥ 10	63200.5	-26319.6	6047.8	-203.233	3783.02	-619.949	805.311
≥ 11	65636.3	-28258.3	6757.23	-214.247	3972.8	-688.56	843.457
≥ 12	68989.7	-30904.4	7626.53	-212.539	3995.62	-678.037	495.032
≥ 13	71616.6	-32962.2	8360.45	-210.386	4009.11	-666.542	317.009
≥ 14	73923.9	-34748	9037.75	-207.668	4020.13	-662.692	183.086
≥ 15	76131.8	-36422.3	9692.32	-203.428	4014.55	-655.981	47.5234
≥ 16	77376.5	-37224.7	10111.4	-207.581	4110.76	-703.37	161.128
≥ 17	80294.9	-39675.9	11065.9	-201.194	4079.24	-691.636	-173.782
≥ 18	82219.8	-41064.8	11672.1	-195.431	4043.83	-675.432	-286.059
≥ 19	84168.9	-42503.6	12309.4	-190.602	4008.19	-656.192	-372.411
≥ 20	86074.2	-43854.4	12935.9	-185.767	3985.57	-656.72	-475.953

Table 2.1.29

**BWR FUEL ASSEMBLY COOLING TIME-DEPENDENT COEFFICIENTS  
(ZR-CLAD FUEL)**

Cooling Time (years)	Array/Class 7x7B						
	A	B	C	D	E	F	G
≥ 3	26409.1	28347.5	-16858	-147.076	5636.32	-1606.75	1177.88
≥ 4	61967.8	-6618.31	-4131.96	-113.949	6122.77	-2042.85	-96.7439
≥ 5	91601.1	-49298.3	17826.5	-132.045	6823.14	-2418.49	-185.189
≥ 6	111369	-80890.1	35713.8	-150.262	7288.51	-2471.1	86.6363
≥ 7	126904	-108669	53338.1	-167.764	7650.57	-2340.78	150.403
≥ 8	139181	-132294	69852.5	-187.317	8098.66	-2336.13	97.5285
≥ 9	150334	-154490	86148.1	-193.899	8232.84	-2040.37	-123.029
≥ 10	159897	-173614	100819	-194.156	8254.99	-1708.32	-373.605
≥ 11	166931	-186860	111502	-193.776	8251.55	-1393.91	-543.677
≥ 12	173691	-201687	125166	-202.578	8626.84	-1642.3	-650.814
≥ 13	180312	-215406	137518	-201.041	8642.19	-1469.45	-810.024
≥ 14	185927	-227005	148721	-197.938	8607.6	-1225.95	-892.876
≥ 15	191151	-236120	156781	-191.625	8451.86	-846.27	-1019.4
≥ 16	195761	-244598	165372	-187.043	8359.19	-572.561	-1068.19
≥ 17	200791	-256573	179816	-197.26	8914.28	-1393.37	-1218.63
≥ 18	206068	-266136	188841	-187.191	8569.56	-730.898	-1363.79
≥ 19	210187	-273609	197794	-182.151	8488.23	-584.727	-1335.59
≥ 20	213731	-278120	203074	-175.864	8395.63	-457.304	-1364.38

Table 2.1.29 (cont'd)

**BWR FUEL ASSEMBLY COOLING TIME-DEPENDENT COEFFICIENTS  
(ZR-CLAD FUEL)**

Cooling Time (years)	Array/Class 8x8B						
	A	B	C	D	E	F	G
≥ 3	28219.6	28963.7	-17616.2	-147.68	5887.41	-1730.96	1048.21
≥ 4	66061.8	-10742.4	-1961.82	-123.066	6565.54	-2356.05	-298.005
≥ 5	95790.7	-53401.7	19836.7	-134.584	7145.41	-2637.09	-298.858
≥ 6	117477	-90055.9	41383.9	-154.758	7613.43	-2612.69	-64.9921
≥ 7	134090	-120643	60983	-168.675	7809	-2183.3	-40.8885
≥ 8	148186	-149181	81418.7	-185.726	8190.07	-2040.31	-260.773
≥ 9	159082	-172081	99175.2	-197.185	8450.86	-1792.04	-381.705
≥ 10	168816	-191389	113810	-195.613	8359.87	-1244.22	-613.594
≥ 11	177221	-210599	131099	-208.3	8810	-1466.49	-819.773
≥ 12	183929	-224384	143405	-207.497	8841.33	-1227.71	-929.708
≥ 13	191093	-240384	158327	-204.95	8760.17	-811.708	-1154.76
≥ 14	196787	-252211	169664	-204.574	8810.95	-610.928	-1208.97
≥ 15	203345	-267656	186057	-208.962	9078.41	-828.954	-1383.76
≥ 16	207973	-276838	196071	-204.592	9024.17	-640.808	-1436.43
≥ 17	213891	-290411	211145	-202.169	9024.19	-482.1	-1595.28
≥ 18	217483	-294066	214600	-194.243	8859.35	-244.684	-1529.61
≥ 19	220504	-297897	219704	-190.161	8794.97	-10.9863	-1433.86
≥ 20	227821	-318395	245322	-194.682	9060.96	-350.308	-1741.16

Table 2.1.29 (cont'd)

BWR FUEL ASSEMBLY COOLING TIME-DEPENDENT COEFFICIENTS  
(ZR-CLAD FUEL)

Cooling Time (years)	Array/Class 8x8C/D/E						
	A	B	C	D	E	F	G
≥ 3	28592.7	28691.5	-17773.6	-149.418	5969.45	-1746.07	1063.62
≥ 4	66720.8	-12115.7	-1154	-128.444	6787.16	-2529.99	-302.155
≥ 5	96929.1	-55827.5	21140.3	-136.228	7259.19	-2685.06	-334.328
≥ 6	118190	-92000.2	42602.5	-162.204	7907.46	-2853.42	-47.5465
≥ 7	135120	-123437	62827.1	-172.397	8059.72	-2385.81	-75.0053
≥ 8	149162	-152986	84543.1	-195.458	8559.11	-2306.54	-183.595
≥ 9	161041	-177511	103020	-200.087	8632.84	-1864.4	-433.081
≥ 10	171754	-201468	122929	-209.799	8952.06	-1802.86	-755.742
≥ 11	179364	-217723	137000	-215.803	9142.37	-1664.82	-847.268
≥ 12	186090	-232150	150255	-216.033	9218.36	-1441.92	-975.817
≥ 13	193571	-249160	165997	-213.204	9146.99	-1011.13	-1119.47
≥ 14	200034	-263671	180359	-210.559	9107.54	-694.626	-1312.55
≥ 15	205581	-275904	193585	-216.242	9446.57	-1040.65	-1428.13
≥ 16	212015	-290101	207594	-210.036	9212.93	-428.321	-1590.7
≥ 17	216775	-299399	218278	-204.611	9187.86	-398.353	-1657.6
≥ 18	220653	-306719	227133	-202.498	9186.34	-181.672	-1611.86
≥ 19	224859	-314004	235956	-193.902	8990.14	145.151	-1604.71
≥ 20	228541	-320787	245449	-200.727	9310.87	-230.252	-1570.18

Table 2.1.29 (cont'd)

**BWR FUEL ASSEMBLY COOLING TIME-DEPENDENT COEFFICIENTS  
(ZR-CLAD FUEL)**

Cooling Time (years)	Array/Class 9x9A						
	A	B	C	D	E	F	G
≥ 3	30538.7	28463.2	-18105.5	-150.039	6226.92	-1876.69	1034.06
≥ 4	71040.1	-16692.2	1164.15	-128.241	7105.27	-2728.58	-414.09
≥ 5	100888	-60277.7	24150.1	-142.541	7896.11	-3272.86	-232.197
≥ 6	124846	-102954	50350.8	-161.849	8350.16	-3163.44	-91.1396
≥ 7	143516	-140615	76456.5	-185.538	8833.04	-2949.38	-104.802
≥ 8	158218	-171718	99788.2	-196.315	9048.88	-2529.26	-259.929
≥ 9	172226	-204312	126620	-214.214	9511.56	-2459.19	-624.954
≥ 10	182700	-227938	146736	-215.793	9555.41	-1959.92	-830.943
≥ 11	190734	-246174	163557	-218.071	9649.43	-1647.5	-935.021
≥ 12	199997	-269577	186406	-223.975	9884.92	-1534.34	-1235.27
≥ 13	207414	-287446	204723	-228.808	10131.7	-1614.49	-1358.61
≥ 14	215263	-306131	223440	-220.919	9928.27	-988.276	-1638.05
≥ 15	221920	-321612	239503	-217.949	9839.02	-554.709	-1784.04
≥ 16	226532	-331778	252234	-216.189	9893.43	-442.149	-1754.72
≥ 17	232959	-348593	272609	-219.907	10126.3	-663.84	-1915.3
≥ 18	240810	-369085	296809	-219.729	10294.6	-859.302	-2218.87
≥ 19	244637	-375057	304456	-210.997	10077.8	-425.446	-2127.83
≥ 20	248112	-379262	309391	-204.191	9863.67	100.27	-2059.39

Table 2.1.29 (cont'd)

**BWR FUEL ASSEMBLY COOLING TIME-DEPENDENT COEFFICIENTS  
(ZR-CLAD FUEL)**

Cooling Time (years)	Array/Class 9x9B						
	A	B	C	D	E	F	G
≥ 3	30613.2	28985.3	-18371	-151.117	6321.55	-1881.28	988.92
≥ 4	71346.6	-15922.9	631.132	-128.876	7232.47	-2810.64	-471.737
≥ 5	102131	-60654.1	23762.7	-140.748	7881.6	-3156.38	-417.979
≥ 6	127187	-105842	51525.2	-162.228	8307.4	-2913.08	-342.13
≥ 7	146853	-145834	79146.5	-185.192	8718.74	-2529.57	-484.885
≥ 8	162013	-178244	103205	-197.825	8896.39	-1921.58	-584.013
≥ 9	176764	-212856	131577	-215.41	9328.18	-1737.12	-1041.11
≥ 10	186900	-235819	151238	-218.98	9388.08	-1179.87	-1202.83
≥ 11	196178	-257688	171031	-220.323	9408.47	-638.53	-1385.16
≥ 12	205366	-280266	192775	-223.715	9592.12	-472.261	-1661.6
≥ 13	215012	-306103	218866	-231.821	9853.37	-361.449	-1985.56
≥ 14	222368	-324558	238655	-228.062	9834.57	3.47358	-2178.84
≥ 15	226705	-332738	247316	-224.659	9696.59	632.172	-2090.75
≥ 16	233846	-349835	265676	-221.533	9649.93	913.747	-2243.34
≥ 17	243979	-379622	300077	-222.351	9792.17	1011.04	-2753.36
≥ 18	247774	-386203	308873	-220.306	9791.37	1164.58	-2612.25
≥ 19	254041	-401906	327901	-213.96	9645.47	1664.94	-2786.2
≥ 20	256003	-402034	330566	-215.242	9850.42	1359.46	-2550.06



Table 2.1.29 (cont'd)

**BWR FUEL ASSEMBLY COOLING TIME-DEPENDENT COEFFICIENTS  
(ZR-CLAD FUEL)**

Cooling Time (years)	Array/Class 9x9C/D						
	A	B	C	D	E	F	G
≥ 3	30051.6	29548.7	-18614.2	-148.276	6148.44	-1810.34	1006
≥ 4	70472.7	-14696.6	-233.567	-127.728	7008.69	-2634.22	-444.373
≥ 5	101298	-59638.9	23065.2	-138.523	7627.57	-2958.03	-377.965
≥ 6	125546	-102740	49217.4	-160.811	8096.34	-2798.88	-259.767
≥ 7	143887	-139261	74100.4	-184.302	8550.86	-2517.19	-275.151
≥ 8	159633	-172741	98641.4	-194.351	8636.89	-1838.81	-486.731
≥ 9	173517	-204709	124803	-212.604	9151.98	-1853.27	-887.137
≥ 10	182895	-225481	142362	-218.251	9262.59	-1408.25	-978.356
≥ 11	192530	-247839	162173	-217.381	9213.58	-818.676	-1222.12
≥ 12	201127	-268201	181030	-215.552	9147.44	-232.221	-1481.55
≥ 13	209538	-289761	203291	-225.092	9588.12	-574.227	-1749.35
≥ 14	216798	-306958	220468	-222.578	9518.22	-69.9307	-1919.71
≥ 15	223515	-323254	237933	-217.398	9366.52	475.506	-2012.93
≥ 16	228796	-334529	250541	-215.004	9369.33	662.325	-2122.75
≥ 17	237256	-356311	273419	-206.483	9029.55	1551.3	-2367.96
≥ 18	242778	-369493	290354	-215.557	9600.71	659.297	-2589.32
≥ 19	246704	-377971	302630	-210.768	9509.41	1025.34	-2476.06
≥ 20	249944	-382059	308281	-205.495	9362.63	1389.71	-2350.49

Table 2.1.29 (cont'd)

**BWR FUEL ASSEMBLY COOLING TIME-DEPENDENT COEFFICIENTS  
(ZR-CLAD FUEL)**

Cooling Time (years)	Array/Class 9x9E/F						
	A	B	C	D	E	F	G
≥ 3	30284.3	26949.5	-16926.4	-147.914	6017.02	-1854.81	1026.15
≥ 4	69727.4	-17117.2	1982.33	-127.983	6874.68	-2673.01	-359.962
≥ 5	98438.9	-58492	23382.2	-138.712	7513.55	-3038.23	-112.641
≥ 6	119765	-95024.1	45261	-159.669	8074.25	-3129.49	221.182
≥ 7	136740	-128219	67940.1	-182.439	8595.68	-3098.17	315.544
≥ 8	150745	-156607	88691.5	-193.941	8908.73	-2947.64	142.072
≥ 9	162915	-182667	109134	-198.37	8999.11	-2531	-93.4908
≥ 10	174000	-208668	131543	-210.777	9365.52	-2511.74	-445.876
≥ 11	181524	-224252	145280	-212.407	9489.67	-2387.49	-544.123
≥ 12	188946	-240952	160787	-210.65	9478.1	-2029.94	-652.339
≥ 13	193762	-250900	171363	-215.798	9742.31	-2179.24	-608.636
≥ 14	203288	-275191	196115	-218.113	9992.5	-2437.71	-1065.92
≥ 15	208108	-284395	205221	-213.956	9857.25	-1970.65	-1082.94
≥ 16	215093	-301828	224757	-209.736	9789.58	-1718.37	-1303.35
≥ 17	220056	-310906	234180	-201.494	9541.73	-1230.42	-1284.15
≥ 18	224545	-320969	247724	-206.807	9892.97	-1790.61	-1381.9
≥ 19	226901	-322168	250395	-204.073	9902.14	-1748.78	-1253.22
≥ 20	235561	-345414	276856	-198.306	9720.78	-1284.14	-1569.18

Table 2.1.29 (cont'd)

BWR FUEL ASSEMBLY COOLING TIME-DEPENDENT COEFFICIENTS  
(ZR-CLAD FUEL)

Cooling Time (years)	Array/Class 9x9G						
	A	B	C	D	E	F	G
≥ 3	35158.5	26918.5	-17976.7	-149.915	6787.19	-2154.29	836.894
≥ 4	77137.2	-19760.1	2371.28	-130.934	8015.43	-3512.38	-455.424
≥ 5	113405	-77931.2	35511.2	-150.637	8932.55	-4099.48	-629.806
≥ 6	139938	-128700	68698.3	-173.799	9451.22	-3847.83	-455.905
≥ 7	164267	-183309	109526	-193.952	9737.91	-3046.84	-737.992
≥ 8	182646	-227630	146275	-210.936	10092.3	-2489.3	-1066.96
≥ 9	199309	-270496	184230	-218.617	10124.3	-1453.81	-1381.41
≥ 10	213186	-308612	221699	-235.828	10703.2	-1483.31	-1821.73
≥ 11	225587	-342892	256242	-236.112	10658.5	-612.076	-2134.65
≥ 12	235725	-370471	285195	-234.378	10604.9	118.591	-2417.89
≥ 13	247043	-404028	323049	-245.79	11158.2	-281.813	-2869.82
≥ 14	253649	-421134	342682	-243.142	11082.3	400.019	-2903.88
≥ 15	262750	-448593	376340	-245.435	11241.2	581.355	-3125.07
≥ 16	270816	-470846	402249	-236.294	10845.4	1791.46	-3293.07
≥ 17	279840	-500272	441964	-241.324	11222.6	1455.84	-3528.25
≥ 18	284533	-511287	458538	-240.905	11367.2	1459.68	-3520.94
≥ 19	295787	-545885	501824	-235.685	11188.2	2082.21	-3954.2
≥ 20	300209	-556936	519174	-229.539	10956	2942.09	-3872.87

Table 2.1.29 (cont'd)

**BWR FUEL ASSEMBLY COOLING TIME-DEPENDENT COEFFICIENTS  
(ZR-CLAD FUEL)**

Cooling Time (years)	Array/Class 10x10A/B						
	A	B	C	D	E	F	G
≥ 3	29285.4	27562.2	-16985	-148.415	5960.56	-1810.79	1001.45
≥ 4	67844.9	-14383	395.619	-127.723	6754.56	-2547.96	-369.267
≥ 5	96660.5	-55383.8	21180.4	-137.17	7296.6	-2793.58	-192.85
≥ 6	118098	-91995	42958	-162.985	7931.44	-2940.84	60.9197
≥ 7	135115	-123721	63588.9	-171.747	8060.23	-2485.59	73.6219
≥ 8	148721	-151690	84143.9	-190.26	8515.81	-2444.25	-63.4649
≥ 9	160770	-177397	104069	-197.534	8673.6	-2101.25	-331.046
≥ 10	170331	-198419	121817	-213.692	9178.33	-2351.54	-472.844
≥ 11	179130	-217799	138652	-209.75	9095.43	-1842.88	-705.254
≥ 12	186070	-232389	151792	-208.946	9104.52	-1565.11	-822.73
≥ 13	192407	-246005	164928	-209.696	9234.7	-1541.54	-979.245
≥ 14	200493	-265596	183851	-207.639	9159.83	-1095.72	-1240.61
≥ 15	205594	-276161	195760	-213.491	9564.23	-1672.22	-1333.64
≥ 16	209386	-282942	204110	-209.322	9515.83	-1506.86	-1286.82
≥ 17	214972	-295149	217095	-202.445	9292.34	-893.6	-1364.97
≥ 18	219312	-302748	225826	-198.667	9272.27	-878.536	-1379.58
≥ 19	223481	-310663	235908	-194.825	9252.9	-785.066	-1379.62
≥ 20	227628	-319115	247597	-199.194	9509.02	-1135.23	-1386.19

Table 2.1.29 (cont'd)

**BWR FUEL ASSEMBLY COOLING TIME-DEPENDENT COEFFICIENTS  
(ZR-CLAD FUEL)**

Cooling Time (years)	Array/Class 10x10C						
	A	B	C	D	E	F	G
≥ 3	31425.3	27358.9	-17413.3	-152.096	6367.53	-1967.91	925.763
≥ 4	71804	-16964.1	1000.4	-129.299	7227.18	-2806.44	-416.92
≥ 5	102685	-62383.3	24971.2	-142.316	7961	-3290.98	-354.784
≥ 6	126962	-105802	51444.6	-164.283	8421.44	-3104.21	-186.615
≥ 7	146284	-145608	79275.5	-188.967	8927.23	-2859.08	-251.163
≥ 8	162748	-181259	105859	-199.122	9052.91	-2206.31	-554.124
≥ 9	176612	-214183	133261	-217.56	9492.17	-1999.28	-860.669
≥ 10	187756	-239944	155315	-219.56	9532.45	-1470.9	-1113.42
≥ 11	196580	-260941	174536	-222.457	9591.64	-944.473	-1225.79
≥ 12	208017	-291492	204805	-233.488	10058.3	-1217.01	-1749.84
≥ 13	214920	-307772	221158	-234.747	10137.1	-897.23	-1868.04
≥ 14	222562	-326471	240234	-228.569	9929.34	-183.47	-2016.12
≥ 15	228844	-342382	258347	-226.944	9936.76	117.061	-2106.05
≥ 16	233907	-353008	270390	-223.179	9910.72	360.39	-2105.23
≥ 17	244153	-383017	304819	-227.266	10103.2	380.393	-2633.23
≥ 18	249240	-395456	321452	-226.989	10284.1	169.947	-2623.67
≥ 19	254343	-406555	335240	-220.569	10070.5	764.689	-2640.2
≥ 20	260202	-421069	354249	-216.255	10069.9	854.497	-2732.77

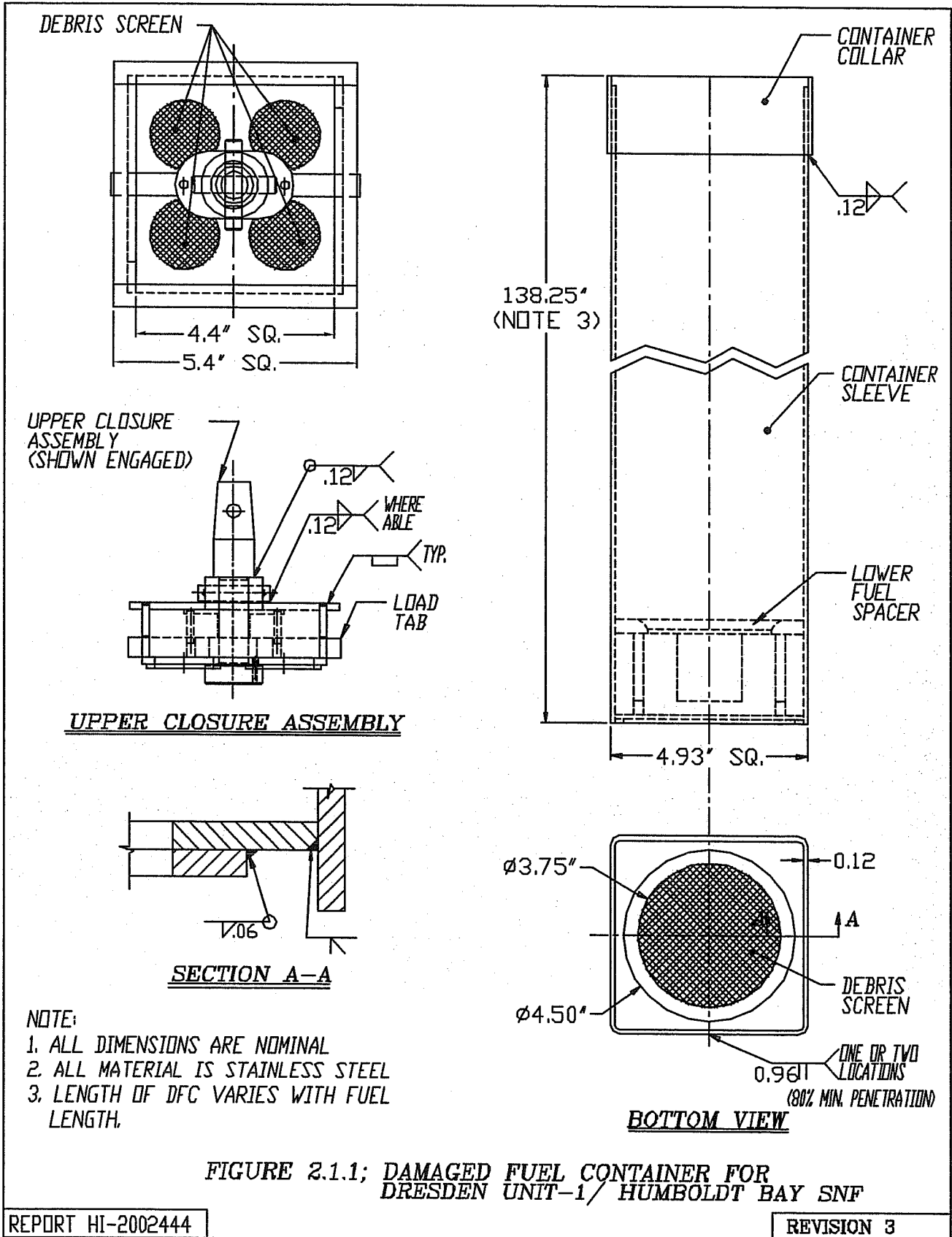

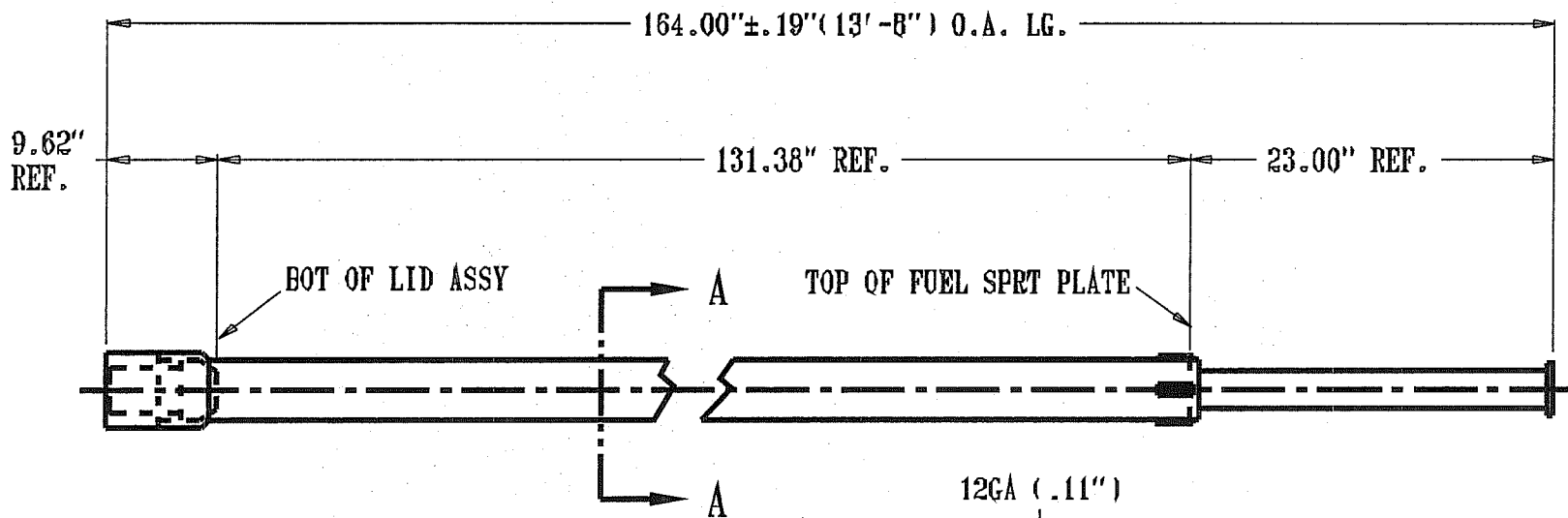

NOTES:

- 1. ALL DIMENSIONS ARE APPROXIMATE.

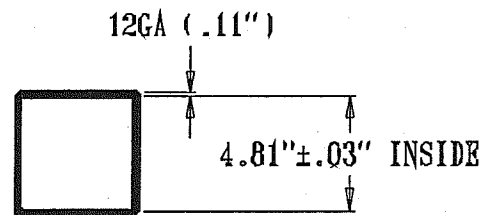

SECTION A-A

FIGURE 2.1.2; TN DAMAGED FUEL CANISTER FOR DRESDEN UNIT-1

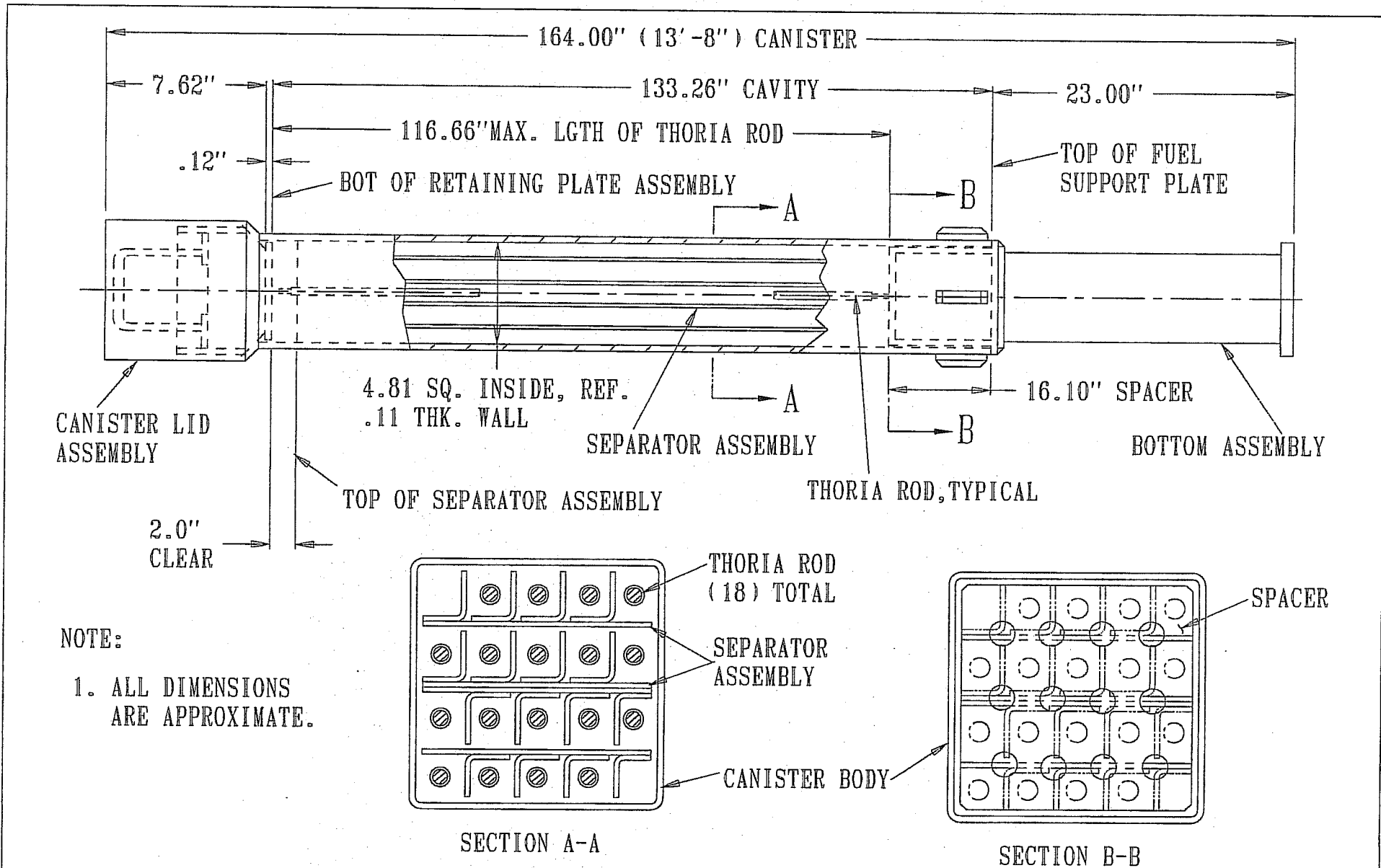

FIGURE 2.1.2A; TN THORIA ROD CANISTER FOR DRESDEN UNIT-1

REPORT HI-2002444

REVISION 1



NOTES:  
 1. ALL DIMENSIONS ARE APPROXIMATE.  
 2. ALL MATERIAL IS STAINLESS STEEL.

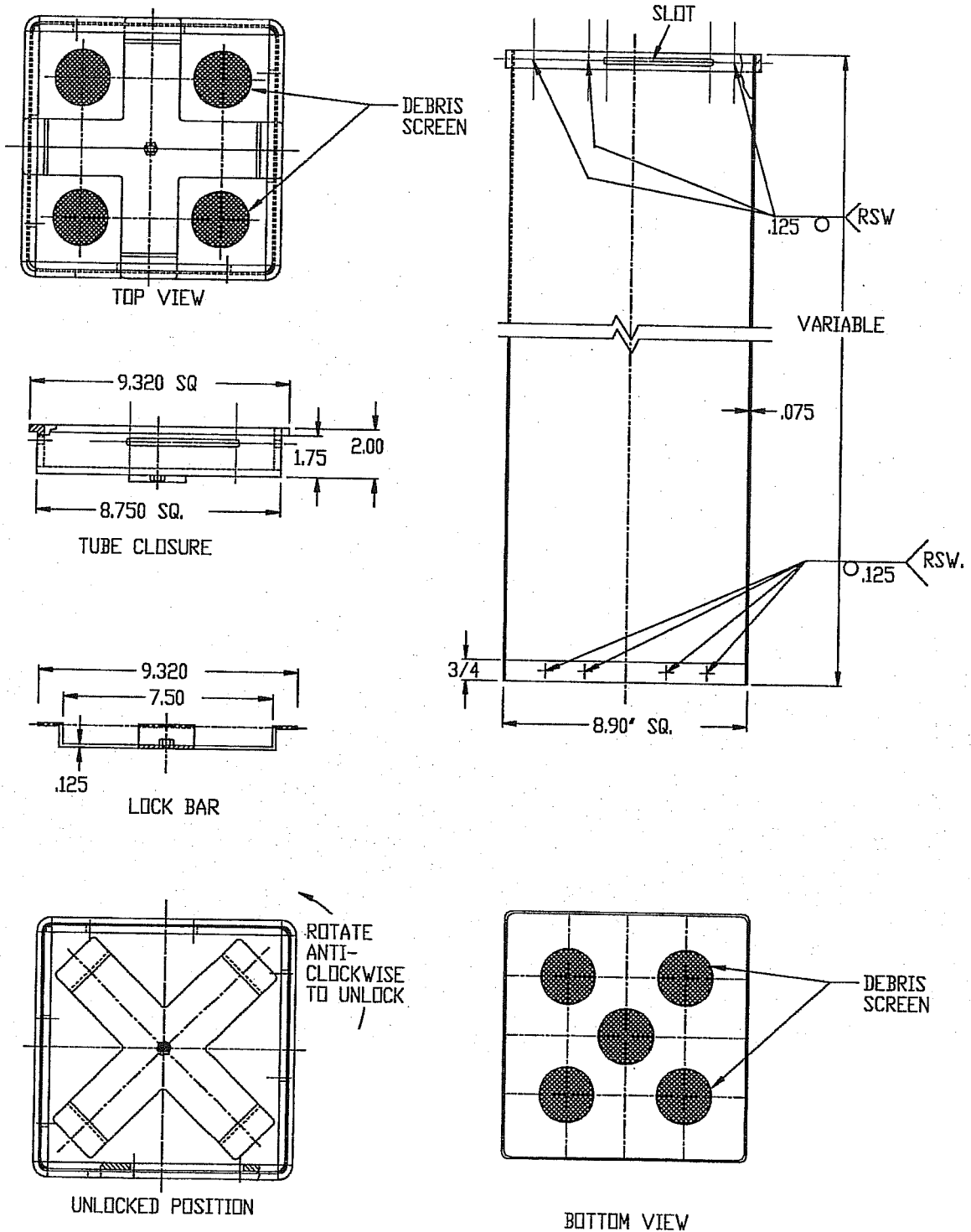
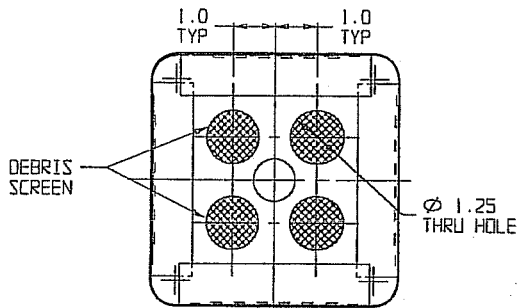
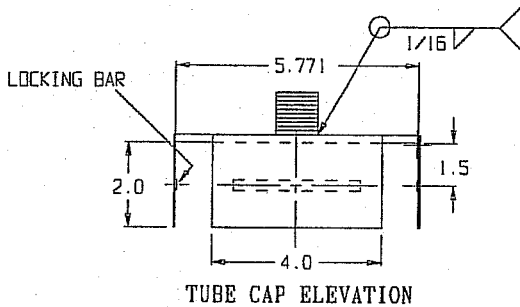

FIGURE 2.1.2B; HOLTEC DAMAGED FUEL CONTAINER FOR PWR SNF IN MPC-24E/24EF



TUBE CAP AND WRAPPER PLAN



TUBE CAP ELEVATION

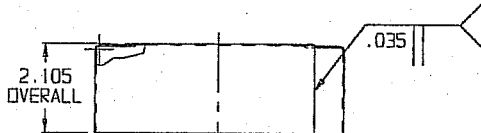

CAP WRAPPER ELEVATION

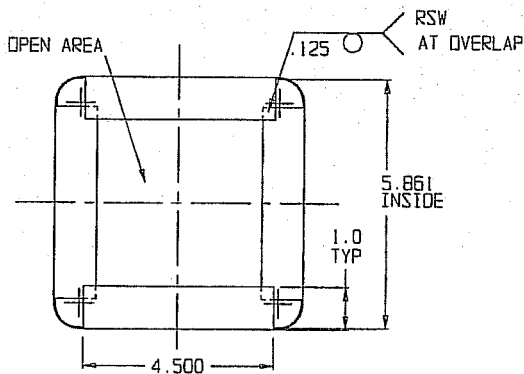

CAP WRAPPER PLAN

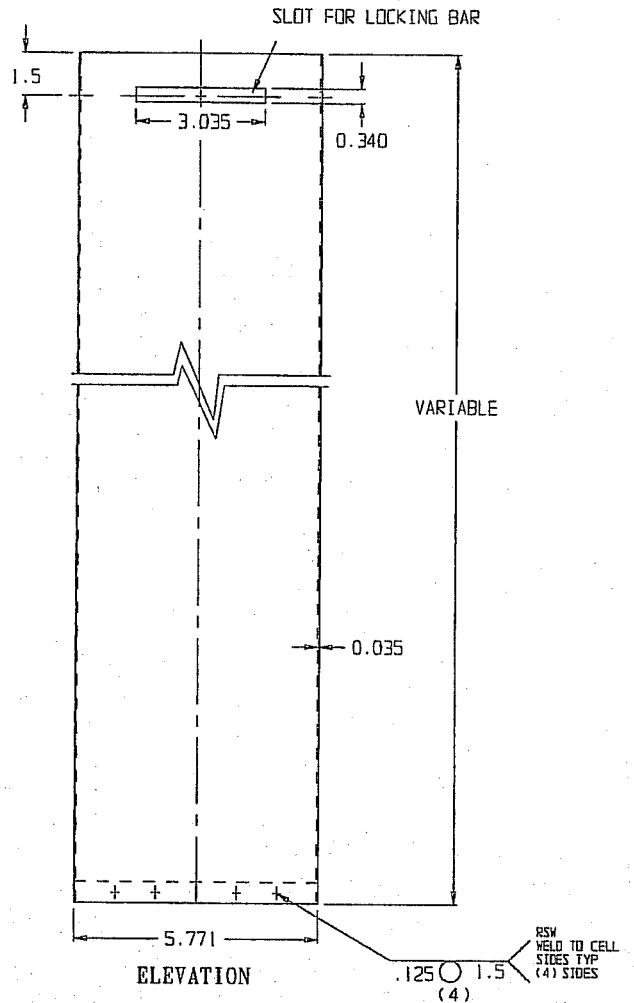

ELEVATION

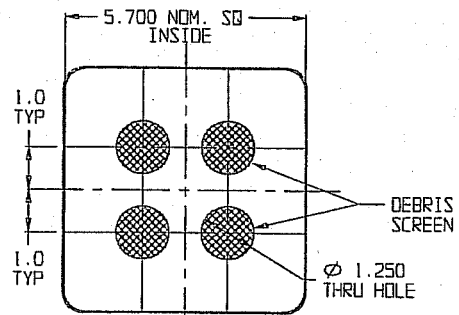

BOTTOM VIEW

FIGURE 2.1.2C; HOLTEC DAMAGED FUEL CONTAINER FOR BWR SNF IN MPC-68/68FF

- NOTES:  
 1. ALL DIMENSIONS ARE IN INCHES AND ARE APPROXIMATE.  
 2. ALL MATERIAL IS STAINLESS STEEL.

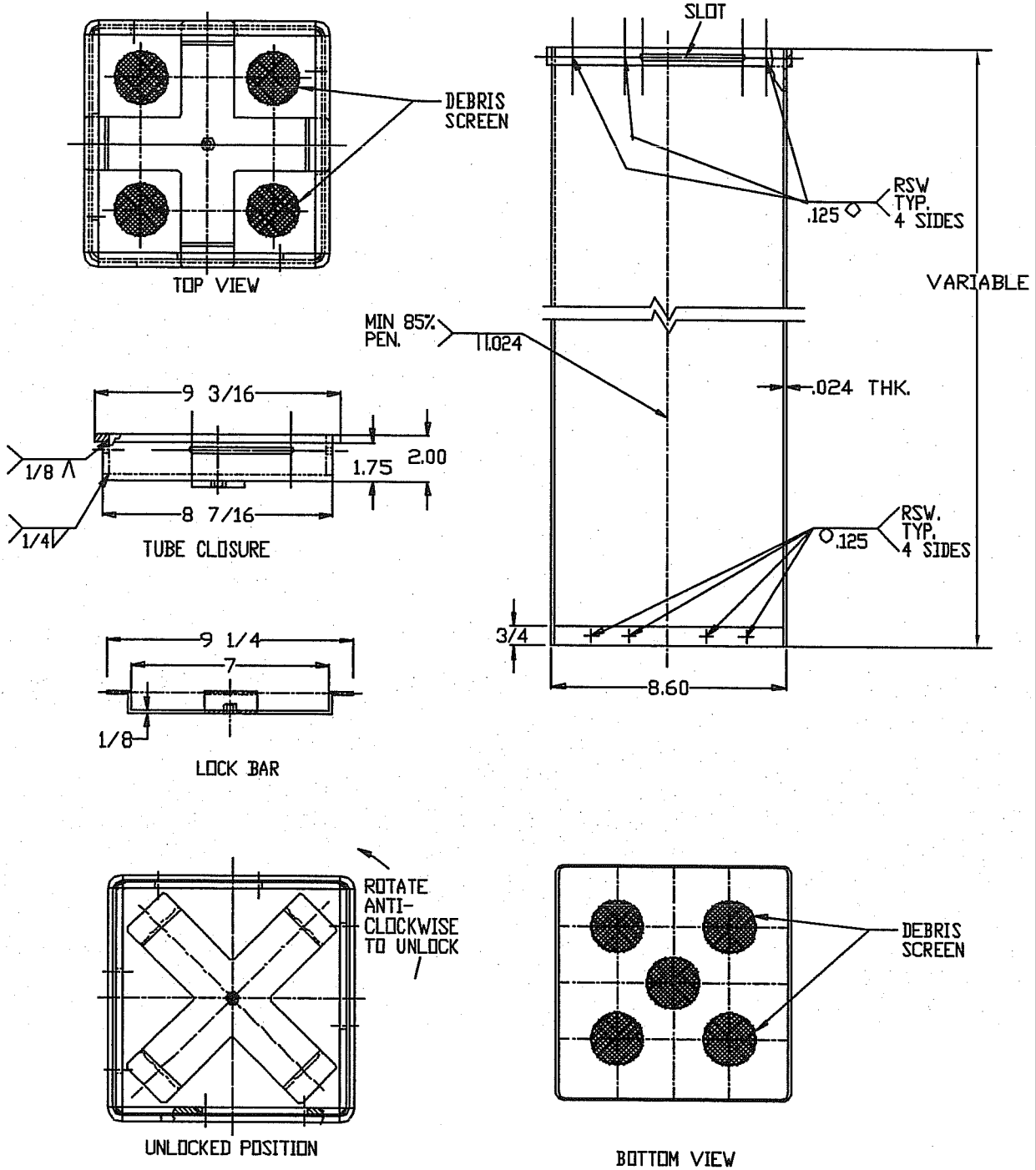

FIGURE 2.1.2D; HOLTEC DAMAGED FUEL CONTAINER FOR PWR SNF IN MPC-32/32F

REPORT HI-2002444

REVISION 3

### PWR Axial Burnup Distribution

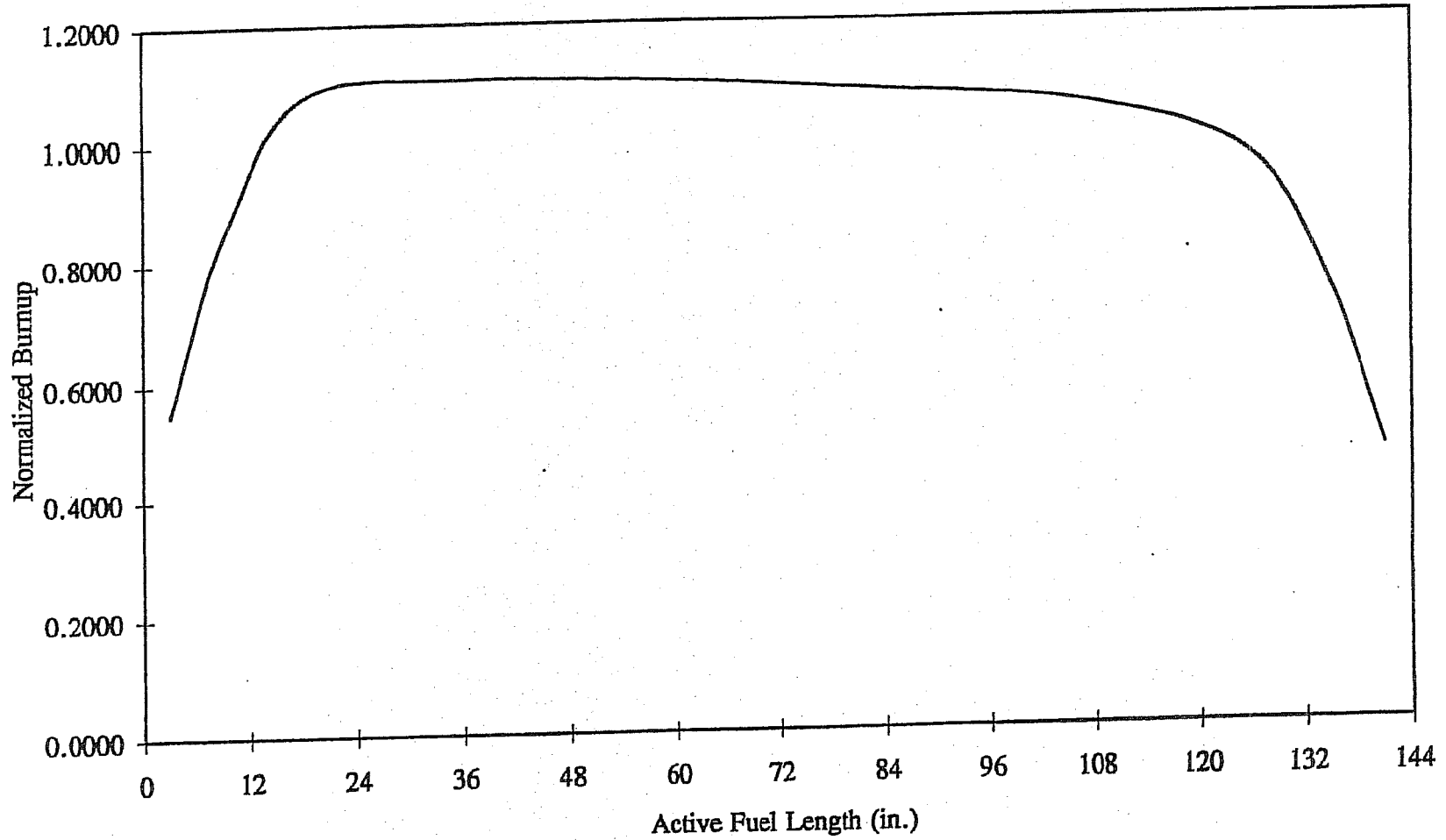

Figure 2.1.3; PWR Axial Burnup Profile with Normalized Distribution

### BWR Axial Burnup Distribution

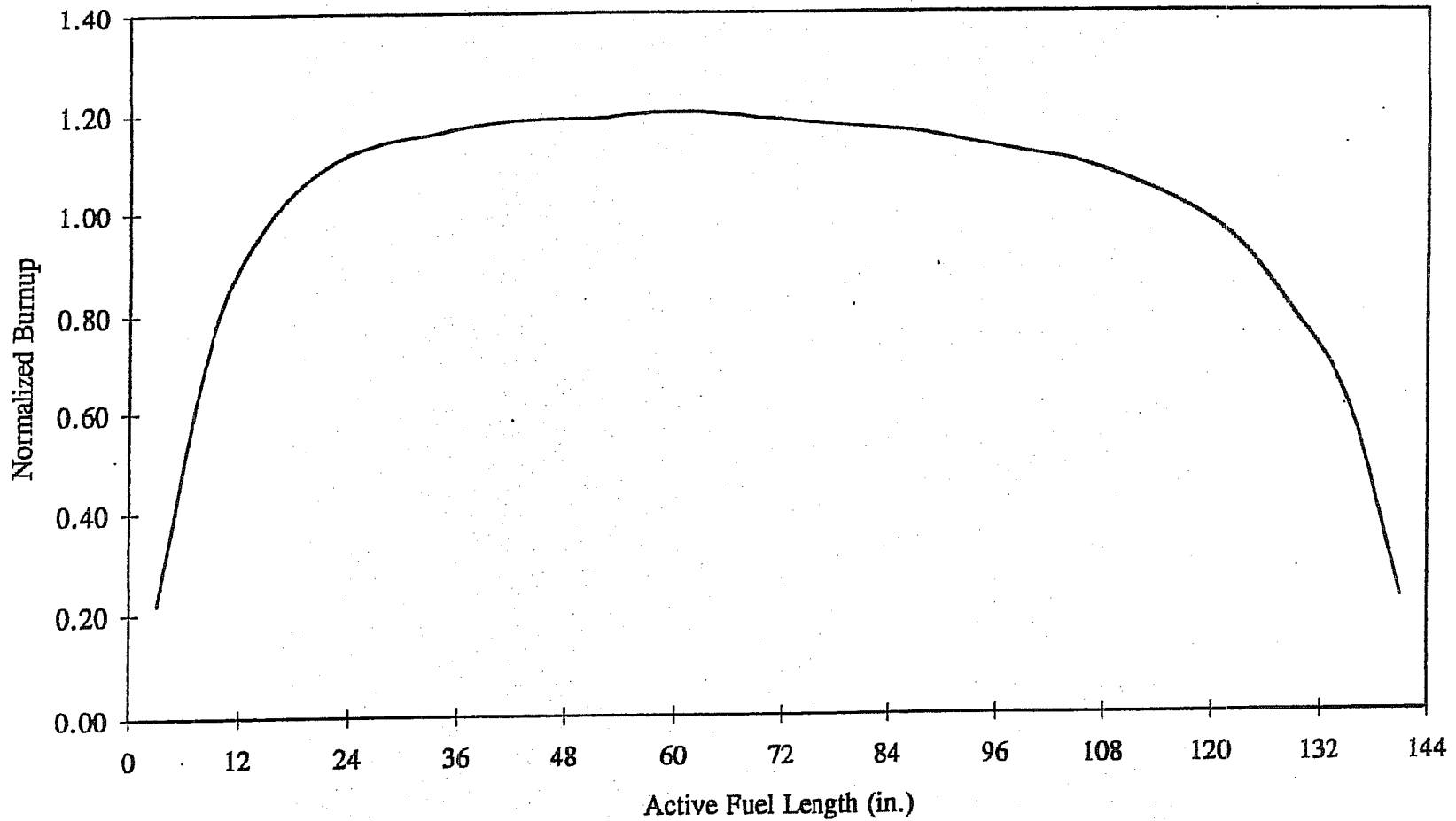

Figure 2.1.4; BWR Axial Burnup Profile with Normalized Distribution

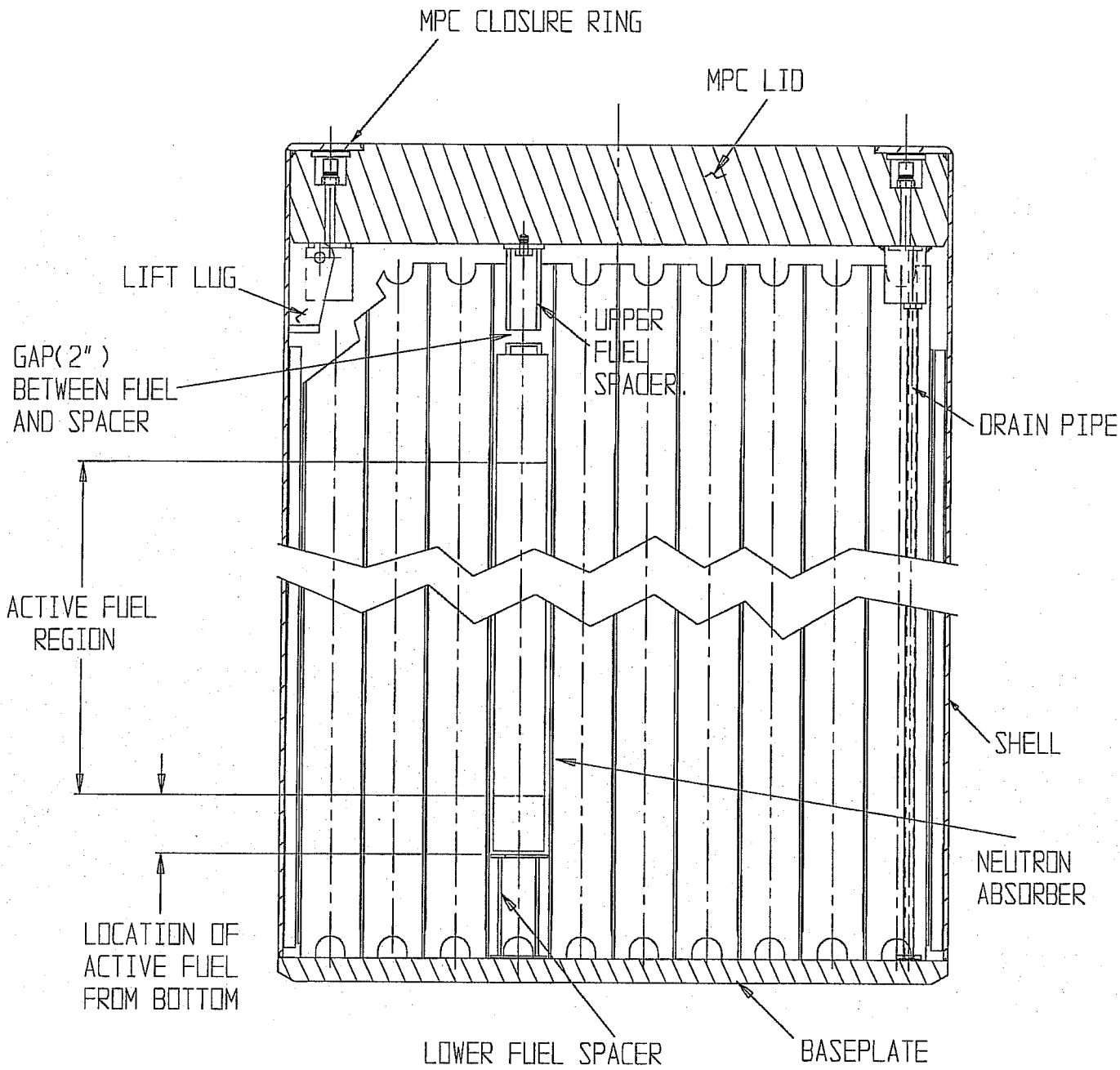

FIGURE 2.1.5; MPC WITH UPPER AND LOWER FUEL SPACERS

**FIGURE 2.1.6**

**INTENTIONALLY DELETED**

DELETED

FIGURE 2.1.7; DELETED



DELETED

FIGURE 2.1.8; DELETED

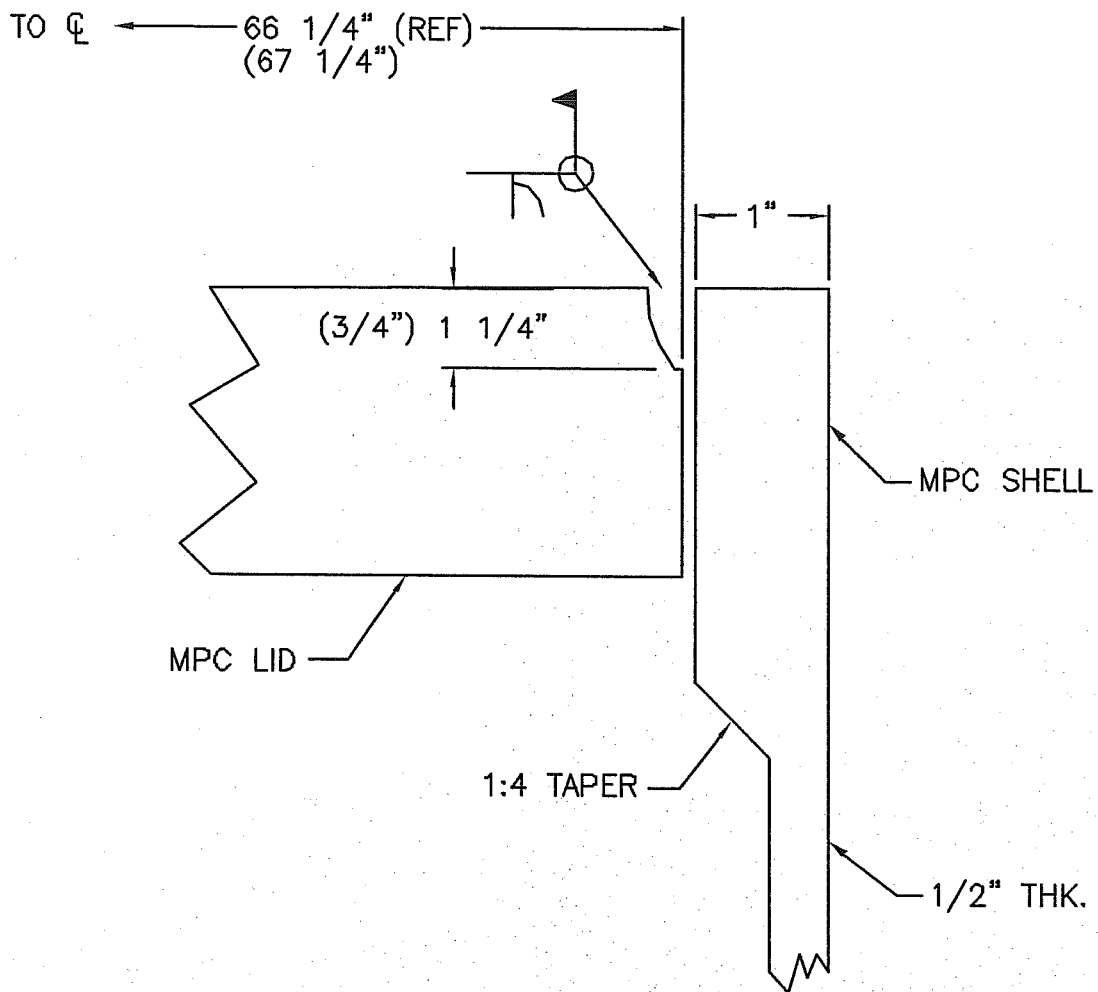

- NOTES: 1. Standard MPC dimensions in parentheses.  
 2. Standard MPC shell thickness is  $\frac{1}{2}''$  along its entire length.  
 3. Figure is not to scale.

Figure 2.1.9; Fuel Debris MPC ( "F" Model)

## 2.2 HI-STORM 100 DESIGN CRITERIA

The HI-STORM 100 System is engineered for unprotected outside storage for the duration of its design life. Accordingly, the cask system is designed to withstand normal, off-normal, and environmental phenomena and accident conditions of storage. Normal conditions include the conditions that are expected to occur regularly or frequently in the course of normal operation. Off-normal conditions include those infrequent events that could reasonably be expected to occur during the lifetime of the cask system. Environmental phenomena and accident conditions include events that are postulated because their consideration establishes a conservative design basis.

Normal condition loads act in combination with all other loads (off-normal or environmental phenomena/accident). Off-normal condition loads and environmental phenomena and accident condition loads are not applied in combination. However, loads that occur as a result of the same phenomena are applied simultaneously. For example, the tornado winds loads are applied in combination with the tornado missile loads.

In the following subsections, the design criteria are established for normal, off-normal, and accident conditions for storage. Loads that require consideration under each condition are identified and the design criteria discussed. Based on consideration of the applicable requirements of the system, the following loads are identified:

Normal (Long-Term Storage) Condition: Dead Weight, Handling, Pressure, Temperature, Snow

Off-Normal Condition: Pressure, Temperature, Leakage of One Seal, Partial Blockage of Air Inlets, Off-Normal Handling of HI-TRAC, Supplemental Cooling System Power Failure

Accident Condition: Handling Accident, Tip-Over, Fire, Partial Blockage of MPC Basket Vent Holes, Tornado, Flood, Earthquake, Fuel Rod Rupture, Confinement Boundary Leakage, Explosion, Lightning, Burial Under Debris, 100% Blockage of Air Inlets, Extreme Environmental Temperature Supplemental Cooling System Operational Failure

Short-Term Operations: This loading condition is defined to accord with ISG-11, Revision 3 guidance [2.0.8]. This includes those normal operational evolutions necessary to support fuel loading or unloading activities. These include, but are not limited to MPC cavity drying, helium backfill, MPC transfer, and on-site handling of a loaded HI-TRAC transfer cask.

Each of these conditions and the applicable loads are identified with applicable design criteria established. Design criteria are deemed to be satisfied if the specified allowable limits are not exceeded.

## 2.2.1 Normal Condition Design Criteria

### 2.2.1.1 Dead Weight

The HI-STORM 100 System must withstand the static loads due to the weights of each of its components, including the weight of the HI-TRAC with the loaded MPC atop the storage overpack.

### 2.2.1.2 Handling

The HI-STORM 100 System must withstand loads experienced during routine handling. Normal handling includes:

- i. vertical lifting and transfer to the ISFSI of the HI-STORM overpack with loaded MPC
- ii. lifting, upending/downending, and transfer to the ISFSI of the HI-TRAC with loaded MPC in the vertical or horizontal position
- iii. lifting of the loaded MPC into and out of the HI-TRAC, HI-STORM, or HI-STAR overpack

The loads shall be increased by 15% to include any dynamic effects from the lifting operations as directed by CMAA #70 [2.2.16].

Handling operations of the loaded HI-TRAC transfer cask or HI-STORM overpack are limited to working area ambient temperatures greater than or equal to 0°F. This limitation is specified to ensure that a sufficient safety margin exists before brittle fracture might occur during handling operations. Subsection 3.1.2.3 provides the demonstration of the adequacy of the HI-TRAC transfer cask and the HI-STORM overpack for use during handling operations at a minimum service temperature of 0° F.

Lifting attachments and devices shall meet the requirements of ANSI N14.6<sup>†</sup> [2.2.3].

### 2.2.1.3 Pressure

The MPC internal pressure is dependent on the initial volume of cover gas (helium), the volume of fill gas in the fuel rods, the fraction of fission gas released from the fuel matrix, the number of fuel rods assumed to have ruptured, and temperature.

The normal condition MPC internal design pressure bounds the cumulative effects of the maximum fill gas volume, normal environmental ambient temperatures, the maximum MPC heat load, and an assumed 1% of the fuel rods ruptured with 100% of the fill gas and 30% of the significant radioactive gases (e.g., H<sup>3</sup>, Kr, and Xe) released in accordance with NUREG-1536.

---

<sup>†</sup> Yield and ultimate strength values used in the stress compliance demonstration per ANSI N14.6 shall utilize confirmed material test data through either independent coupon testing or material suppliers= CMTR or COC, as appropriate. To ensure consistency between the design and fabrication of a lifting component, compliance with ANSI N14.6 in this FSAR implies that the guidelines of ASME Section III, Subsection NF for Class 3 structures are followed for material procurement and testing, fabrication, and for NDE during manufacturing.

Table 2.2.1 provides the design pressures for the HI-STORM 100 System.

For the storage of damaged fuel assemblies or fuel debris in a damaged fuel container, it is conservatively assumed that 100% of the fuel rods are ruptured with 100% of the rod fill gas and 30% of the significant radioactive gases (e.g., H<sup>3</sup>, Kr, and Xe) released for both normal and off-normal conditions. For PWR assemblies stored with non-fuel hardware, it is assumed that 100% of the gasses in the non-fuel hardware (e.g., BPRAs) is also released. This condition is bounded by the pressure calculation for design basis intact fuel with 100% of the fuel rods ruptured in all of the fuel assemblies. It is shown in Chapter 4 that the accident condition design pressure is not exceeded with 100% of the fuel rods ruptured in all of the design basis fuel assemblies. Therefore, rupture of 100% of the fuel rods in the damaged fuel assemblies or fuel debris will not cause the MPC internal pressure to exceed the accident design pressure.

The MPC internal design pressure under accident conditions is discussed in Subsection 2.2.3.

The HI-STORM overpack and MPC external pressure is a function of environmental conditions, which may produce a pressure loading. The normal and off-normal condition external design pressure is set at ambient standard pressure (1 atmosphere).

The HI-STORM overpack is not capable of retaining internal pressure due to its open design, and, therefore, no analysis is required or provided for the overpack internal pressure.

The HI-TRAC is not capable of retaining internal pressure due to its open design and, therefore, ambient and hydrostatic pressures are the only pressures experienced. Due to the thick steel walls of the HI-TRAC transfer cask, it is evident that the small hydrostatic pressure can be easily withstood; no analysis is required or provided for the HI-TRAC internal pressure. However, the HI-TRAC water jacket does experience internal pressure due to the heat-up of the water contained in the water jacket. Analysis is presented in Chapter 3 that demonstrates that the design pressure in Table 2.2.1 can be withstood by the water jacket and Chapter 4 demonstrates by analysis that the water jacket design pressure will not be exceeded. To provide an additional layer of safety, a pressure relief device set at the design pressure is provided, which ensures the pressure will not be exceeded.

#### 2.2.1.4 Environmental Temperatures

To evaluate the long-term effects of ambient temperatures on the HI-STORM 100 System, an upper bound value on the annual average ambient temperatures for the continental United States is used. The normal temperature specified in Table 2.2.2 is bounding for all reactor sites in the contiguous United States. The "normal" temperature set forth in Table 2.2.2 is intended to ensure that it is greater than the annual average of ambient temperatures at any location in the continental United States. In the northern region of the U.S., the design basis "normal" temperature used in this FSAR will be exceeded only for brief periods, whereas in the southern U.S., it may be straddled daily in summer months. Inasmuch as the sole effect of the "normal" temperature is on the computed fuel cladding temperature to establish long-term fuel integrity, it should not lie below the time averaged

yearly mean for the ISFSI site. Previously licensed cask systems have employed lower "normal" temperatures (viz. 75° F in Docket 72-1007) by utilizing national meteorological data.

Likewise, within the thermal analysis, a conservatively assumed soil temperature of the value specified in Table 2.2.2 is utilized to bound the annual average soil temperatures for the continental United States. The 1987 ASHRAE Handbook (HVAC Systems and Applications) reports average earth temperatures, from 0 to 10 feet below grade, throughout the continental United States. The highest reported annual average value for the continental United States is 77° F for Key West, Florida. Therefore, this value is specified in Table 2.2.2 as the bounding soil temperature.

Confirmation of the site-specific annual average ambient temperature and soil temperature is to be performed by the licensee, in accordance with 10CFR72.212. The annual average temperature is combined with insolation in accordance with 10CFR71.71 averaged over 24 hours to establish the normal condition temperatures in the HI-STORM 100 System.

#### 2.2.1.5 Design Temperatures

The ASME Boiler and Pressure Vessel Code (ASME Code) requires that the value of the vessel design temperature be established with appropriate consideration for the effect of heat generation internal or external to the vessel. The decay heat load from the spent nuclear fuel is the internal heat generation source for the HI-STORM 100 System. The ASME Code (Section III, Paragraph NCA-2142) requires the design temperature to be set at or above the maximum through thickness mean metal temperature of the pressure part under normal service (Level A) condition. Consistent with the terminology of NUREG-1536, we refer to this temperature as the "Design Temperature for Normal Conditions". Conservative calculations of the steady-state temperature field in the HI-STORM 100 System, under assumed environmental normal temperatures with the maximum decay heat load, result in HI-STORM component temperatures at or below the normal condition design temperatures for the HI-STORM 100 System defined in Table 2.2.3.

Maintaining fuel rod cladding integrity is also a design consideration. The fuel rod peak cladding temperature (PCT) limits for the long-term storage and short-term normal operating conditions meet the intent of the guidance in ISG-11, Revision 3 [2.0.8]. For moderate burnup fuel, the previously licensed PCT limit of 570°C (1058°F) may be used [2.0.9] (see also Section 4.5).

#### 2.2.1.6 Snow and Ice

The HI-STORM 100 System must be capable of withstanding pressure loads due to snow and ice. ASCE 7-88 (formerly ANSI A58.1) [2.2.2] provides empirical formulas and tables to compute the effective design pressure on the overpack due to the accumulation of snow for the contiguous U.S. and Alaska. Typical calculated values for heated structures such as the HI-STORM 100 System range from 50 to 70 pounds per square foot. For conservatism, the snow pressure loading is set at a level in Table 2.2.8 which bounds the ASCE 7-88 recommendation.

## 2.2.2 Off-Normal Conditions Design Criteria

As the HI-STORM 100 System is passive, loss of power and instrumentation failures are not defined as off-normal conditions. The off-normal condition design criteria are defined in the following subsections.

A discussion of the effects of each off-normal condition is provided in Section 11.1. Section 11.1 also provides the corrective action for each off-normal condition. The location of the detailed analysis for each event is referenced in Section 11.1.

### 2.2.2.1 Pressure

The HI-STORM 100 System must withstand loads due to off-normal pressure. The off-normal condition MPC internal design pressure bounds the cumulative effects of the maximum fill gas volume, off-normal environmental ambient temperatures, the maximum MPC heat load, and an assumed 10% of the fuel rods ruptured with 100% of the fill gas and 30% of the significant radioactive gases (e.g., H<sup>3</sup>, Kr, and Xe) released in accordance with NUREG-1536.

### 2.2.2.2 Environmental Temperatures

The HI-STORM 100 System must withstand off-normal environmental temperatures. The off-normal environmental temperatures are specified in Table 2.2.2. The lower bound temperature occurs with no solar loads and the upper bound temperature occurs with steady-state insolation. Each bounding temperature is assumed to persist for a duration sufficient to allow the system to reach steady-state temperatures.

Limits on the peaks in the time-varying ambient temperature at an ISFSI site is recognized in the FSAR in the specification of the off-normal temperatures. The lower bound off-normal temperature is defined as the minimum of the 72-hour average of the ambient temperature at an ISFSI site. Likewise, the upper bound off-normal temperature is defined by the maximum of 72-hour average of the ambient temperature. The lower and upper bound off-normal temperatures listed in Table 2.2.2 are intended to cover all ISFSI sites in the continent U.S. The 72-hour average of temperature used in the definition of the off-normal temperature recognizes the considerable thermal inertia of the HI-STORM 100 storage system which reduces the effect of undulations in instantaneous temperature on the internals of the multi-purpose canister.

### 2.2.2.3 Design Temperatures

In addition to the normal condition design temperatures, which apply to long-term storage and short-term normal operating conditions (e.g., MPC drying operations and onsite transport operations), we also define an "off-normal/accident condition temperature" pursuant to the provisions of NUREG-1536 and Regulatory Guide 3.61. This is, in effect, the temperature, which may exist during a transient event (examples of such instances are the overpack blocked air duct off-normal event and fire accident). The off-normal/accident design temperatures of Table 2.2.3 are set down to bound the maximax (maximum in time and space) value of the thru-thickness average temperature of the

structural or non-structural part, as applicable, during the transient event. These enveloping values, therefore, will bound the maximum temperature reached anywhere in the part, excluding skin effects during or immediately after, a transient event.

#### 2.2.2.4 Leakage of One Seal

The MPC enclosure vessel is designed to have no credible leakage under all normal, off-normal, and hypothetical accident conditions of storage.

The confinement boundary is defined by the MPC shell, baseplate, MPC lid, port cover plates, closure ring, and associated welds. Most confinement boundary welds are inspected by radiography or ultrasonic examination. Field welds are examined by the liquid penetrant method on the root (if more than one weld pass is required) and final weld passes. In addition to liquid penetrant examination, the MPC lid-to-shell weld is pressure tested, and volumetrically examined or multi-pass liquid penetrant examined. The vent and drain port cover plates are subject to liquid penetrant examination. These inspection and testing techniques are performed to verify the integrity of the confinement boundary.

#### 2.2.2.5 Partial Blockage of Air Inlets

The HI-STORM 100 System must withstand the partial blockage of the overpack air inlets. This event is conservatively defined as a complete blockage of two (2) of the four air inlets. Because the overpack air inlets and outlets are covered by fine mesh steel screens, located 90° apart, and inspected routinely (or alternatively, exit vent air temperature monitored), it is unlikely that all vents could become blocked by blowing debris, animals, etc. during normal and off-normal operations. Two of the air inlets are conservatively assumed to be completely blocked to demonstrate the inherent thermal stability of the HI-STORM 100 System.

#### 2.2.2.6 Off-Normal HI-TRAC Handling

During upending and/or downending of the HI-TRAC 100 or HI-TRAC 125 transfer cask, the total lifted weight is distributed among both the upper lifting trunnions and the lower pocket trunnions. Each of the four trunnions on the HI-TRAC therefore supports approximately one-quarter of the total weight. This even distribution of the load would continue during the entire rotation operation. The HI-TRAC 100D and 125D transfer cask designs do not include pocket trunnions. Therefore, the entire load is held by the lifting trunnions.

If the lifting device cables begin to “go slack” while upending or downending the HI-TRAC 100 or HI-TRAC 125, the eccentricity of the pocket trunnions would immediately cause the cask to pivot, restoring tension on the cables. Nevertheless, the pocket trunnions are conservatively analyzed to support one-half of the total weight, doubling the load per trunnion. This condition is analyzed to demonstrate that the pocket trunnions in the standard HI-TRAC design possess sufficient strength to support the increased load under this off-normal condition.



## 2.2.3 Environmental Phenomena and Accident Condition Design Criteria

Environmental phenomena and accident condition design criteria are defined in the following subsections.

The minimum acceptance criteria for the evaluation of the accident conditions are that the MPC confinement boundary maintains radioactive material confinement, the MPC fuel basket structure maintains the fuel contents subcritical, the stored SNF can be retrieved by normal means, and the system provides adequate shielding.

A discussion of the effects of each environmental phenomenon and accident condition is provided in Section 11.2. The consequences of each accident or environmental phenomenon are evaluated against the requirements of 10CFR72.106 and 10CFR20. Section 11.2 also provides the corrective action for each event. The location of the detailed analysis for each event is referenced in Section 11.2.

### 2.2.3.1 Handling Accident

The HI-STORM 100 System must withstand loads due to a handling accident. Even though the loaded HI-STORM 100 System will be lifted in accordance with approved, written procedures and may use lifting equipment which complies with ANSI N14.6-1993 [2.2.3], certain drop events are considered herein to demonstrate the defense-in-depth features of the design.

The loaded HI-STORM overpack will be lifted so that the bottom of the cask is at a height less than the vertical lift limit (see Table 2.2.8) above the ground. For conservatism, the postulated drop event assumes that the loaded HI-STORM 100 overpack falls freely from the vertical lift limit height before impacting a thick reinforced concrete pad. The deceleration of the cask must be maintained below 45 g's. Additionally, the overpack must continue to suitably shield the radiation emitted from the loaded MPC. The use of lifting devices designed in accordance with ANSI N14.6 having redundant drop protection features to lift the loaded overpack will eliminate the lift height limit. The lift height limit is dependent on the characteristics of the impacting surface, which are specified in Table 2.2.9. For site-specific conditions, which are not encompassed by Table 2.2.9, the licensee shall evaluate the site-specific conditions to ensure that the drop accident loads do not exceed 45 g's. The methodology used in this alternative analysis shall be commensurate with the analyses in Appendix 3.A and shall be reviewed by the Certificate Holder.

The loaded HI-TRAC will be lifted so that the lowest point on the transfer cask (i.e., the bottom edge of the cask/lid assemblage) is at a height less than the calculated horizontal lift height limit (see Table 2.2.8) above the ground, when lifted horizontally outside of the reactor facility. For conservatism, the postulated drop event assumes that the loaded HI-TRAC falls freely from the horizontal lift height limit before impact.

Analysis is provided that demonstrates that the HI-TRAC continues to suitably shield the radiation emitted from the loaded MPC, and that the HI-TRAC end plates (top lid and transfer lid for HI-TRAC 100 and HI-TRAC 125 and the top lid and pool lid for HI-TRAC 100D and 125D) remain

attached. Furthermore, the HI-TRAC inner shell is demonstrated by analysis to not deform sufficiently to hinder retrieval of the MPC. The horizontal lift height limit is dependent on the characteristics of the impacting surface, which are specified in Table 2.2.9. For site-specific conditions, which are not encompassed by Table 2.2.9, the licensee shall evaluate the site-specific conditions to ensure that the drop accident loads do not exceed 45 g's. The methodology used in this alternative analysis shall be commensurate with the methodology described in this FSAR and shall be reviewed by the Certificate Holder. The use of lifting devices designed in accordance with ANSI N14.6 having redundant drop protection features during horizontal lifting of the loaded HI-TRAC outside of the reactor facilities eliminate the need for a horizontal lift height limit.

The loaded HI-TRAC, when lifted in the vertical position outside of the Part 50 facility shall be lifted with devices designed in accordance with ANSI N14.6 and having redundant drop protection features unless a site-specific analysis has been performed to determine a lift height limit. For vertical lifts of HI-TRAC with suitably designed lift devices, a vertical drop is not a credible accident for the HI-TRAC transfer cask and no vertical lift height limit is required to be established. Likewise, while the loaded HI-TRAC is positioned atop the HI-STORM 100 overpack for transfer of the MPC into the overpack (outside the Part 50 facility), the lifting equipment will remain engaged with the lifting trunnions of the HI-TRAC transfer cask or suitable restraints will be provided to secure the HI-TRAC. This ensures that a tip-over or drop from atop the HI-STORM 100 overpack is not a credible accident for the HI-TRAC transfer cask. The design criteria and conditions of use for MPC transfer operations from the HI-TRAC transfer cask to the HI-STORM 100 overpack at a Cask Transfer Facility are specified in Subsection 2.3.3.1 of this FSAR.

The loaded MPC is lowered into the HI-STORM or HI-STAR overpack or raised from the overpack using the HI-TRAC transfer cask and a MPC lifting system designed in accordance with ANSI N14.6 and having redundant drop protection features. Therefore, the possibility of a loaded MPC falling freely from its highest elevation during the MPC transfer operations into the HI-STORM or HI-STAR overpacks is not credible.

The magnitude of loadings imparted to the HI-STORM 100 System due to drop events is heavily influenced by the compliance characteristics of the impacted surface. Two "pre-approved" concrete pad designs for storing the HI-STORM 100 System are presented in Table 2.2.9. Other ISFSI pad designs may be used provided the designs are reviewed by the Certificate Holder to ensure that impactive and impulsive loads under accident events such as cask drop and non-mechanistic tip-over are less than the design basis limits when analyzed using the methodologies established in this FSAR.

#### 2.2.3.2 Tip-Over

The free-standing HI-STORM 100 System is demonstrated by analysis to remain kinematically stable under the design basis environmental phenomena (tornado, earthquake, etc.). However, the HI-STORM 100 overpack and MPC shall also withstand impacts due to a hypothetical tip-over event. The structural integrity of a loaded HI-STORM 100 System after a tip-over onto a reinforced concrete pad is demonstrated by analysis. The cask tip-over is not postulated as an outcome of any environmental phenomenon or accident condition. The cask tip-over is a non-mechanistic event.

The ISFSI pad for deploying a free-standing HI-STORM overpack must possess sufficient structural stiffness to meet the strength limits set forth in the ACI Code selected by the ISFSI owner. At the same time, the pad must be sufficiently compliant such that the maximum deceleration under a tip-over event is below the limit set forth in Table 3.1.2 of this FSAR.

During original licensing for the HI-STORM 100 System, a single set of ISFSI pad and subgrade design parameters (now labeled Set A) was established. Experience has shown that achieving a maximum concrete compressive strength (at 28 days) of 4,200 psi can be difficult. Therefore, a second set of ISFSI pad and subgrade design parameters (labeled Set B) has been developed. The Set B ISFSI parameters include a thinner concrete pad and less stiff subgrade, which allow for a higher concrete compressive strength. Cask deceleration values for all design basis drop and tipover events with the HI-STORM 100, HI-STORM 100S, and HI-STORM 100S Version B overpacks have been verified to be less than or equal to the design limit of 45 g's for both sets of ISFSI pad parameters.

The original set and the new set (Set B) of acceptable ISFSI pad and subgrade design parameters are specified in Table 2.2.9. Users may design their ISFSI pads and subgrade in compliance with either parameter Set A or Set B. Alternatively, users may design their site-specific ISFSI pads and subgrade using any combination of design parameters resulting in a structurally competent pad that meets the provisions of ACI-318 and also limits the deceleration of the cask to less than or equal to 45 g's for the design basis drop and tip-over events for the HI-STORM 100, HI-STORM 100S, and HI-STORM 100S Version B overpacks. The structural analyses for site-specific ISFSI pad design shall be performed using methodologies consistent with those described in this FSAR, as applicable.

If the HI-STORM 100 System is deployed in an anchored configuration (HI-STORM 100A), then tip-over of the cask is structurally precluded along with the requirement of target compliance, which warrants setting specific limits on the concrete compressive strength and subgrade Young's Modulus. Rather, at the so-called high seismic sites (ZPAs greater than the limit set forth in the CoC for free standing casks), the ISFSI pad must be sufficiently rigid to hold the anchor studs and maintain the integrity of the fastening mechanism embedded in the pad during the postulated seismic event. The ISFSI pad must be designed to minimize a physical uplift during extreme environmental event (viz., tornado missile, DBE, etc.). The requirements on the ISFSI pad to render the cask anchoring function under long-term storage are provided in Section 2.0.4.

### 2.2.3.3 Fire

The possibility of a fire accident near an ISFSI site is considered to be extremely remote due to the absence of significant combustible materials. The only credible concern is related to a transport vehicle fuel tank fire engulfing the loaded HI-STORM 100 overpack or HI-TRAC transfer cask while it is being moved to the ISFSI.

The HI-STORM 100 System must withstand temperatures due to a fire event. The HI-STORM overpack and HI-TRAC transfer cask fire accidents for storage are conservatively postulated to be the result of the spillage and ignition of 50 gallons of combustible transporter fuel. The HI-STORM

overpack and HI-TRAC transfer cask surfaces are considered to receive an incident radiation and forced convection heat flux from the fire. Table 2.2.8 provides the fire durations for the HI-STORM overpack and HI-TRAC transfer cask based on the amount of flammable materials assumed. The temperature of fire is assumed to be 1475° F in accordance with 10CFR71.73.

The accident condition design temperatures for the HI-STORM 100 System, and the fuel rod cladding limits are specified in Table 2.2.3. The specified fuel cladding temperature limits are based on the temperature limits specified in ISG-11, Rev. 3 [2.0.9].

#### 2.2.3.4 Partial Blockage of MPC Basket Vent Holes

The HI-STORM 100 System is designed to withstand reduction of flow area due to partial blockage of the MPC basket vent holes. As the MPC basket vent holes are internal to the confinement barrier, the only events that could partially block the vents are fuel cladding failure and debris associated with this failure, or the collection of crud at the base of the stored SNF assembly. The HI-STORM 100 System maintains the SNF in an inert environment with fuel rod cladding temperatures below accepted values (Table 2.2.3). Therefore, there is no credible mechanism for gross fuel cladding degradation during storage in the HI-STORM 100. For the storage of damaged BWR fuel assemblies or fuel debris, the assemblies and fuel debris will be placed in damaged fuel containers prior to placement in the MPC. The damaged fuel container is equipped with mesh screens which ensure that the damaged fuel and fuel debris will not escape to block the MPC basket vent holes. In addition, each MPC will be loaded once for long-term storage and, therefore, buildup of crud in the MPC due to numerous loadings is precluded. Using crud quantities reported in an Empire State Electric Energy Research Corporation Report [2.2.6], a layer of crud of conservative depth is assumed to partially block the MPC basket vent holes. The crud depths for the different MPCs are listed in Table 2.2.8.

#### 2.2.3.5 Tornado

The HI-STORM 100 System must withstand pressures, wind loads, and missiles generated by a tornado. The prescribed design basis tornado and wind loads for the HI-STORM 100 System are consistent with NRC Regulatory Guide 1.76 [2.2.7], ANSI 57.9 [2.2.8], and ASCE 7-88 [2.2.2]. Table 2.2.4 provides the wind speeds and pressure drops which the HI-STORM 100 overpack must withstand while maintaining kinematic stability. The pressure drop is bounded by the accident condition MPC external design pressure.

The kinematic stability of the HI-STORM overpack, and continued integrity of the MPC confinement boundary, while within the storage overpack or HI-TRAC transfer cask, must be demonstrated under impact from tornado-generated missiles in conjunction with the wind loadings. Standard Review Plan (SRP) 3.5.1.4 of NUREG-0800 [2.2.9] stipulates that the postulated missiles include at least three objects: a massive high kinetic energy missile that deforms on impact (large missile); a rigid missile to test penetration resistance (penetrant missile); and a small rigid missile of a size sufficient to pass through any openings in the protective barriers (micro-missile). SRP 3.5.1.4 suggests an automobile for a large missile, a rigid solid steel cylinder for the penetrant missile, and a solid sphere for the small rigid missile, all impacting at 35% of the maximum horizontal wind speed of the design basis tornado. Table 2.2.5 provides the missile data used in the analysis, which is based

on the above SRP guidelines. The effects of a large tornado missile are considered to bound the effects of a light general aviation airplane crashing on an ISFSI facility.

During horizontal handling of the loaded HI-TRAC transfer cask outside the Part 50 facility, tornado missile protection shall be provided to prevent tornado missiles from impacting either end of the HI-TRAC. The tornado missile protection shall be designed such that the large tornado missile cannot impact the bottom or top of the loaded HI-TRAC, while in the horizontal position. Also, the missile protection for the top of the HI-TRAC shall be designed to preclude the penetrant missile and micro-missile from passing through the penetration in the HI-TRAC top lid, while in the horizontal position. With the tornado missile protection in place, the impacting of a large tornado missile on either end of the loaded HI-TRAC or the penetrant missile or micro-missile entering the penetration of the top lid is not credible. Therefore, no analyses of these impacts are provided.

#### 2.2.3.6 Flood

The HI-STORM 100 System must withstand pressure and water forces associated with a flood. Resultant loads on the HI-STORM 100 System consist of buoyancy effects, static pressure loads, and velocity pressure due to water velocity. The flood is assumed to deeply submerge the HI-STORM 100 System (see Table 2.2.8). The flood water depth is based on the hydrostatic pressure which is bounded by the MPC external pressure stated in Table 2.2.1.

It must be shown that the MPC does not collapse, buckle, or allow water in-leakage under the hydrostatic pressure from the flood.

The flood water is assumed to be nonstagnant. The maximum allowable flood water velocity is determined by calculating the equivalent pressure loading required to slide or tip over the HI-STORM 100 System. The design basis flood water velocity is stated in Table 2.2.8. Site-specific safety reviews by the licensee must confirm that flood parameters do not exceed the flood depth, slide, or tip-over forces.

If the flood water depth exceeds the elevation of the top of the HI-STORM overpack inlet vents, then the cooling air flow would be blocked. The flood water may also carry debris which may act to block the air inlets of the overpack. Blockage of the air inlets is addressed in Subsection 2.2.3.13.

Most reactor sites are hydrologically characterized as required by Paragraph 100.10(c) of 10CFR100 and further articulated in Reg. Guide 1.59, "Design Basis Floods for Nuclear Power Plants" and Reg. Guide 1.102, "Flood Protection for Nuclear Power Plants." It is assumed that a complete characterization of the ISFSI's hydrosphere including the effects of hurricanes, floods, seiches and tsunamis is available to enable a site-specific evaluation of the HI-STORM 100 System for kinematic stability. An evaluation for tsunamis<sup>†</sup> for certain coastal sites should also be performed to demonstrate that sliding or tip-over will not occur and that the maximum flood depth will not be exceeded.

---

<sup>†</sup> A tsunami is an ocean wave from seismic or volcanic activity or from submarine landslides. A tsunami may be the result of nearby or distant events. A tsunami loading may exist in combination with wave splash and spray, storm surge and tides.

Analysis for each site for such transient hydrological loadings must be made for that site. It is expected that the plant licensee will perform this evaluation under the provisions of 10CFR72.212.

#### 2.2.3.7 Seismic Design Loadings

The HI-STORM 100 System must withstand loads arising due to a seismic event and must be shown not to tip over during a seismic event. Subsection 3.4.7 contains calculations based on conservative static "incipient tipping" calculations which demonstrate static stability. The calculations in Section 3.4.7 result in the values reported in Table 2.2.8, which provide the maximum horizontal zero period acceleration (ZPA) versus vertical acceleration multiplier above which static incipient tipping would occur. This conservatively assumes the peak acceleration values of each of the two horizontal earthquake components and the vertical component occur simultaneously. The maximum horizontal ZPA provided in Table 2.2.8 is the vector sum of two horizontal earthquakes.

For anchored casks, the limit on zero period accelerations is set by the structural capacity of the sector lugs and anchoring studs. Table 2.2.8 provides the limits for HI-STORM 100A for the maximum vector sum of two horizontal earthquake peak ZPA's along with the coincident limit on the vertical ZPA.

#### 2.2.3.8 100% Fuel Rod Rupture

The HI-STORM 100 System must withstand loads due to 100% fuel rod rupture. For conservatism, 100 percent of the fuel rods are assumed to rupture with 100 percent of the fill gas and 30% of the significant radioactive gases (e.g., H<sup>3</sup>, Kr, and Xe) released in accordance with NUREG-1536. All of the fill gas contained in non-fuel hardware, such as Burnable Poison Rod Assemblies (BPRAs) is also assumed to be released in analyzing this event.

#### 2.2.3.9 Confinement Boundary Leakage

No credible scenario has been identified that would cause failure of the confinement system. Section 7.1 provides a discussion as to why leakage of any magnitude from the MPC is not credible, based on the materials and methods of fabrication and inspection.

#### 2.2.3.10 Explosion

The HI-STORM 100 System must withstand loads due to an explosion. The accident condition MPC external pressure and overpack pressure differential specified in Table 2.2.1 bounds all credible external explosion events. There are no credible internal explosive events since all materials are compatible with the various operating environments, as discussed in Section 3.4.1, or appropriate preventive measures are taken to preclude internal explosive events (see Section 1.2.1.3.1.1). The MPC is composed of stainless steel, neutron absorber material, and prior to CoC Amendment 2, possibly optional aluminum alloy 1100 heat conduction elements. For these materials, and considering the protective measures taken during loading and unloading operations there is no credible internal explosive event.

#### 2.2.3.11 Lightning

The HI-STORM 100 System must withstand loads due to lightning. The effect of lightning on the HI-STORM 100 System is evaluated in Chapter 11.

#### 2.2.3.12 Burial Under Debris

The HI-STORM 100 System must withstand burial under debris. Such debris may result from floods, wind storms, or mud slides. Mud slides, blowing debris from a tornado, or debris in flood water may result in duct blockage, which is addressed in Subsection 2.2.3.13. The thermal effects of burial under debris on the HI-STORM 100 System is evaluated in Chapter 11. Siting of the ISFSI pad shall ensure that the storage location is not located near shifting soil. Burial under debris is a highly unlikely accident, but is analyzed in this FSAR.

#### 2.2.3.13 100% Blockage of Air Inlets

For conservatism, this accident is defined as a complete blockage of all four bottom air inlets. Such a blockage may be postulated to occur during accident events such as a flood or tornado with blowing debris. The HI-STORM 100 System must withstand the temperature rise as a result of 100% blockage of the air inlets and outlets. The fuel cladding temperature must be shown to remain below the off-normal/accident temperature limit specified in Table 2.2.3.

#### 2.2.3.14 Extreme Environmental Temperature

The HI-STORM 100 System must withstand extreme environmental temperatures. The extreme accident level temperature is specified in Table 2.2.2. The extreme accident level temperature occurs with steady-state insolation. This temperature is assumed to persist for a duration sufficient to allow the system to reach steady-state temperatures. The HI-STORM overpack and MPC have a large thermal inertia. Therefore, this temperature is assumed to persist over three days (3-day average).

#### 2.2.3.15 Bounding Hydraulic, Wind, and Missile Loads for HI-STORM 100A

In the anchored configuration, the HI-STORM 100A System is clearly capable of withstanding much greater lateral loads than a free-standing overpack. Coastal sites in many areas of the world, particularly the land mass around the Pacific Ocean, may be subject to severe fluid inertial loads. Several publications [2.2.10, 2.2.11] explain and quantify the nature and source of such environmental hazards.

It is recognized that a lateral fluid load may also be accompanied by an impact force from a fluid borne missile (debris). Rather than setting specific limits for these loads on an individual basis, a limit on the static overturning base moment on the anchorage is set. This bounding overturning moment is given in Table 2.2.8 and is set at a level that ensures that structural safety margins on the sector lugs and on the anchor studs are essentially equal to the structural safety margins of the same components under the combined effect of the net horizontal and vertical seismic load limits in Table

2.2.8. The ISFSI owner bears the responsibility to establish that the lateral hydraulic, wind, and missile loads at his ISFSI site do not yield net overturning moments, when acting separately or together, that exceed the limit value in Table 2.2.8. If loadings are increased above those values for free-standing casks, their potential effect on the other portions of the cask system must be considered.

#### 2.2.4 Applicability of Governing Documents

The ASME Boiler and Pressure Vessel Code (ASME Code), 1995 Edition, with Addenda through 1997 [2.2.1], is the governing code for the structural design of the MPC, the metal structure of the HI-STORM 100 overpack, and the HI-TRAC transfer cask, except for Sections V and IX. The latest effective editions of ASME Section V and IX may be used, provided a written reconciliation of the later edition against the 1995 Edition, including addenda, is performed by the certificate holder. The MPC enclosure vessel and fuel basket are designed in accordance with Section III, Subsections NB Class 1 and NG Class 1, respectively. The metal structure of the overpack and the HI-TRAC transfer cask are designed in accordance with Section III, Subsection NF Class 3. The ASME Code is applied to each component consistent with the function of the component.

ACI 349 is the governing code for the plain concrete in the HI-STORM 100 overpack. ACI 318-95 is the applicable code utilized to determine the allowable compressive strength of the plain concrete credited during structural analysis. Appendix 1.D provides the sections of ACI 349 and ACI 318-95 applicable to the plain concrete.

Table 2.2.6 provides a summary of each structure, system and component (SSC) of the HI-STORM 100 System that is identified as important to safety, along with its function and governing Code. Some components perform multiple functions and in those cases, the most restrictive Code is applied. In accordance with NUREG/CR-6407, "Classification of Transportation Packaging and Dry Spent Fuel Storage System Components", and according to importance to safety, components of the HI-STORM 100 System are classified as A, B, C, or NITS (not important to safety) in Table 2.2.6. Section 13.1 provides the criteria used to classify each item. The classification of necessary auxiliary equipment is provided in Table 8.1.6.

Table 2.2.7 lists the applicable governing Code for material procurement, design, fabrication and inspection of the components of the HI-STORM 100 System. The ASME Code section listed in the design column is the section used to define allowable stresses for structural analyses.

Table 2.2.15 lists the alternatives to the ASME Code for the HI-STORM 100 System and the justification for those alternatives.

The MPC enclosure vessel and certain fuel basket designs utilized in the HI-STORM 100 System are identical to the MPC components described in the SARs for the HI-STAR 100 System for storage (Docket 72-1008) and transport (Docket 71-9261). To avoid unnecessary repetition of the large numbers of stress analyses, this document refers to those SARs, as applicable, if the MPC loadings for storage in the HI-STORM 100 System do not exceed those computed in the HI-STAR documents. Many of the loadings in the HI-STAR applications envelope the HI-STORM loadings on



the MPC, and, therefore, a complete re-analysis of the MPC is not provided in the FSAR. Certain individual MPC analyses may have been required to license a particular MPC fuel basket design for HI-STORM that was not previously licensed for HI-STAR. These unique analyses are summarized in the appropriate location in this FSAR.

Table 2.2.16 provides a summary comparison between the loading elements. Table 2.2.16 shows that most of the loadings remain unchanged and several are less than the HI-STAR loading conditions. In addition to the magnitude of the loadings experienced by the MPC, the application of the loading must also be considered. Therefore, it is evident from Table 2.2.16 that the MPC stress limits can be ascertained to be qualified a priori if the HI-STAR analyses and the thermal loadings under HI-STORM storage are not more severe compared to previously analyzed HI-STAR conditions. In the analysis of each of the normal, off-normal, and accident conditions, the effect on the MPC is evaluated and compared to the corresponding condition analyzed in the HI-STAR 100 System SARs [2.2.4 and 2.2.5]. If the HI-STORM loading is greater than the HI-STAR loading or the loading is applied differently, the analysis of its effect on the MPC is evaluated in Chapter 3.

#### 2.2.5 Service Limits

In the ASME Code, plant and system operating conditions are commonly referred to as normal, upset, emergency, and faulted. Consistent with the terminology in NRC documents, this FSAR utilizes the terms normal, off-normal, and accident conditions.

The ASME Code defines four service conditions in addition to the Design Limits for nuclear components. They are referred to as Level A, Level B, Level C, and Level D service limits, respectively. Their definitions are provided in Paragraph NCA-2142.4 of the ASME Code. The four levels are used in this FSAR as follows:

- a. Level A Service Limits: Level A Service Limits are used to establish allowables for normal condition load combinations.
- b. Level B Service Limits: Level B Service Limits are used to establish allowables for off-normal condition load combinations.
- c. Level C Service Limits: Level C Service Limits are not used.
- d. Level D Service Limits: Level D Service Limits are used to establish allowables for accident condition load combinations.

The ASME Code service limits are used in the structural analyses for definition of allowable stresses and allowable stress intensities. Allowable stresses and stress intensities for structural analyses are tabulated in Chapter 3. These service limits are matched with normal, off-normal, and accident condition loads combinations in the following subsections.

The MPC confinement boundary is required to meet Section III, Class 1, Subsection NB stress intensity limits. Table 2.2.10 lists the stress intensity limits for the Levels A, B, C, and D service

limits for Class 1 structures extracted from the ASME Code (1995 Edition). The limits for the MPC fuel basket, required to meet the stress intensity limits of Subsection NG of the ASME Code, are listed in Table 2.2.11. Table 2.2.12 lists allowable stress limits for the steel structure of the HI-STORM overpack and HI-TRAC which are analyzed to meet the stress limits of Subsection NF, Class 3. Only service levels A, B, and D requirements, normal, off-normal, and accident conditions, are applicable.

#### 2.2.6 Loads

Subsections 2.2.1, 2.2.2, and 2.2.3 describe the design criteria for normal, off-normal, and accident conditions, respectively. Table 2.2.13 identifies the notation for the individual loads that require consideration. The individual loads listed in Table 2.2.13 are defined from the design criteria. Each load is assigned a symbol for subsequent use in the load combinations.

The loadings listed in Table 2.2.13 fall into two broad categories; namely, (i) those that primarily affect kinematic stability, and (ii) those that produce significant stresses. The loadings in the former category are principally applicable to the overpack. Tornado wind ( $W'$ ), earthquake (E), and tornado-borne missile (M) are essentially loadings which can destabilize a cask. Analyses reported in Chapter 3 show that the HI-STORM 100 overpack structure will remain kinematically stable under these loadings. Additionally, for the missile impact case (M), analyses that demonstrate that the overpack structure remains unbreached by the postulated missiles are provided in Chapter 3.

Loadings in the second category produce global stresses that must be shown to comply with the stress intensity or stress limits, as applicable. The relevant loading combinations for the fuel basket, the MPC, the HI-TRAC and the HI-STORM overpack are different because of differences in their function. For example, the fuel basket does not experience a pressure loading because it is not a pressure vessel. The specific load combination for each component is specified in Subsection 2.2.7.

#### 2.2.7 Load Combinations

To demonstrate compliance with the design requirements for normal, off-normal, and accident conditions of storage, the individual loads, identified in Table 2.2.13, are combined into load combinations. In the formation of the load combinations, it is recognized that the number of combinations requiring detailed analyses is reduced by defining bounding loads. Analyses performed using bounding loads serve to satisfy the requirements for analysis of a multitude of separately identified loads in combination.

For example, the values established for internal and external pressures ( $P_i$  and  $P_o$ ) are defined such that they bound other surface-intensive loads, namely snow (S), tornado wind ( $W'$ ), flood (F), and explosion ( $E^*$ ). Thus, evaluation of pressure in a load combination established for a given storage condition enables many individual load effects to be included in a single load combination.

Table 2.2.14 identifies the combinations of the loads that are required to be considered in order to ensure compliance with the design criteria set forth in this chapter. Table 2.2.14 presents the load combinations in terms of the loads that must be considered together. A number of load combinations

are established for each ASME Service Level. Within each loading case, there may be more than one analysis that is required to demonstrate compliance. Since the breakdown into specific analyses is most applicable to the structural evaluation, the identification of individual analyses with the applicable loads for each load combination is found in Chapter 3. Table 3.1.3 through 3.1.5 define the particular evaluations of loadings that demonstrate compliance with the load combinations of Table 2.2.14.

For structural analysis purposes, Table 2.2.14 serves as an intermediate classification table between the definition of the loads (Table 2.2.13 and Section 2.2) and the detailed analysis combinations (Tables 3.1.3 through 3.1.5).

Finally, it should be noted that the load combinations identified in NUREG-1536 are considered as applicable to the HI-STORM 100 System. The majority of load combinations in NUREG-1536 are directed toward reinforced concrete structures. Those load combinations applicable to steel structures are directed toward frame structures. As stated in NUREG-1536, Page 3-35 of Table 3-1, "Table 3-1 does not apply to the analysis of confinement casks and other components designed in accordance with Section III of the ASME B&PV Code." Since the HI-STORM 100 System is a metal shell structure, with concrete primarily employed as shielding, the load combinations of NUREG-1536 are interpreted within the confines and intent of the ASME Code.

#### 2.2.8 Allowable Stresses

The stress intensity limits for the MPC confinement boundary for the design condition and the service conditions are provided in Table 2.2.10. The MPC confinement boundary stress intensity limits are obtained from ASME Code, Section III, Subsection NB. The stress intensity limits for the MPC fuel basket are presented in Table 2.2.11 (governed by Subsection NG of Section III). The steel structure of the overpack and the HI-TRAC meet the stress limits of Subsection NF of ASME Code, Section III for plate and shell components. Limits for the Level D condition are obtained from Appendix F of ASME Code, Section III for the steel structure of the overpack. The ASME Code is not applicable to the HI-TRAC transfer cask for accident conditions, service level D conditions. The HI-TRAC transfer cask has been shown by analysis to not deform sufficiently to apply a load to the MPC, have any shell rupture, or have the top lid, pool lid, or transfer lid (as applicable) detach.

The following definitions of terms apply to the tables on stress intensity limits; these definitions are the same as those used throughout the ASME Code:

- $S_m$ : Value of Design Stress Intensity listed in ASME Code Section II, Part D, Tables 2A, 2B and 4
- $S_y$ : Minimum yield strength at temperature
- $S_u$ : Minimum ultimate strength at temperature

Table 2.2.1

## DESIGN PRESSURES

<b>Pressure Location</b>	<b>Condition</b>	<b>Pressure (psig)</b>
MPC Internal Pressure	Normal	100
	Off-Normal	110
	Accident	200
MPC External Pressure	Normal	(0) Ambient
	Off-Normal	(0) Ambient
	Accident	60
Overpack External Pressure	Normal	(0) Ambient
	Off-Normal	(0) Ambient
	Accident	10 (differential pressure for 1 second maximum)* or 5 (differential pressure steady state)
HI-TRAC Water Jacket	Normal	60
	Off-normal	60
	Accident	N/A (Under accident conditions, the water jacket is assumed to have lost all water thru the pressure relief valves)

\* The overpack is also qualified to sustain without tip-over a lateral impulse load of 60 psi (differential pressure for 85 milliseconds maximum) [3.4.5].

Table 2.2.2

## ENVIRONMENTAL TEMPERATURES

Condition	Temperature (°F)	Comments
HI-STORM 100 Overpack		
Normal Ambient (Bounding Annual Average)	80	
Normal Soil Temperature (Bounding Annual Average)	77	
Off-Normal Ambient (3-Day Average)	-40 and 100	-40°F with no insolation  100°F with insolation
Extreme Accident Level Ambient (3-Day Average)	125	125°F with insolation starting at steady-state off-normal high environment temperature
HI-TRAC Transfer Cask		
Normal (Bounding Annual Average)	100	
Off-Normal (3-Day Average)	0 and 100	0° F with no insolation  100° F with insolation

## Note:

1. Handling operations with the loaded HI-STORM overpack and HI-TRAC transfer cask are limited to working area ambient temperatures greater than or equal to 0°F as specified in Subsection 2.2.1.2.

Table 2.2.3

## DESIGN TEMPERATURES

<b>HI-STORM 100 Component</b>	<b>Long Term, Normal Condition Design Temperature Limits (Long-Term Events) (° F)</b>	<b>Off-Normal and Accident Condition Temperature Limits (Short-Term Events)<sup>†</sup> (° F)</b>
MPC shell	500	775
MPC basket	725	950
MPC Neutron Absorber	800	950
MPC lid	550	775
MPC closure ring	400	775
MPC baseplate	400	775
MPC Heat Conduction Elements	725	950
HI-TRAC inner shell	400	600
HI-TRAC pool lid/transfer lid	350	700
HI-TRAC top lid	400	700
HI-TRAC top flange	400	700
HI-TRAC pool lid seals	350	N/A
HI-TRAC bottom lid bolts	350	700
HI-TRAC bottom flange	350	700
HI-TRAC top lid neutron shielding	300	350
HI-TRAC radial neutron shield	307	N/A
HI-TRAC radial lead gamma shield	350	600
Remainder of HI-TRAC	350	700
Fuel Cladding	752	752 or 1058 (Short Term Operations) <sup>††</sup>  1058 (Off-normal and Accident Conditions)
Overpack outer shell	350	600
Overpack concrete	300	350
Overpack inner shell	350	400
Overpack Lid Top and Bottom Plate	450	550

<sup>†</sup> For accident conditions that involve heating of the steel structures and no mechanical loading (such as the blocked air duct accident), the permissible metal temperature of the steel parts is defined by Table 1A of ASME Section II (Part D) for Section III, Class 3 materials as 700°F. For the ISFSI fire event, the maximum temperature limit for ASME Section 1 equipment is appropriate (850°F in Code Table 1A).

<sup>††</sup> Normal short term operations includes MPC drying and onsite transport per Reference [2.0.8]. The 1058°F temperature limit applies to MPCs containing all moderate burnup fuel as discussed in Reference [2.0.9]. The limit for MPCs containing one or more high burnup fuel assemblies is 752°F. See also Section 4.3.

Table 2.2.3 (continued)

DESIGN TEMPERATURES

<b>HI-STORM 100 Component</b>	<b>Long Term, Normal Condition Design Temperature Limits (Long-Term Events) (° F)</b>	<b>Off-Normal and Accident Condition Temperature Limits (Short-Term Events)<sup>†</sup> (° F)</b>
Remainder of overpack steel structure	350	400

Table 2.2.4

TORNADO CHARACTERISTICS

<b>Condition</b>	<b>Value</b>
Rotational wind speed (mph)	290
Translational speed (mph)	70
Maximum wind speed (mph)	360
Pressure drop (psi)	3.0



Table 2.2.5

TORNADO-GENERATED MISSILES

<b>Missile Description</b>	<b>Mass (kg)</b>	<b>Velocity (mph)</b>
Automobile	1800	126
Rigid solid steel cylinder (8 in. diameter)	125	126
Solid sphere (1 in. diameter)	0.22	126

TABLE 2.2.6

MATERIALS AND COMPONENTS OF THE HI-STORM 100 SYSTEM  
MPC <sup>(1,2)</sup>

Primary Function	Component <sup>(3)</sup>	Safety Class <sup>(4)</sup>	Codes/Standards (as applicable to component)	Material	Strength ( ksi)	Special Surface Finish/Coating	Contact Matl. ( if dissimilar)
Confinement	Shell	A	ASME Section III; Subsection NB	Alloy X <sup>(5)</sup>	See Appendix 1.A	NA	NA
Confinement	Baseplate	A	ASME Section III; Subsection NB	Alloy X	See Appendix 1.A	NA	NA
Confinement	Lid (One-piece design and top portion of optional two-piece design)	A	ASME Section III; Subsection NB	Alloy X	See Appendix 1.A	NA	NA
Confinement	Closure Ring	A	ASME Section III; Subsection NB	Alloy X	See Appendix 1.A	NA	NA
Confinement	Port Cover Plates	A	ASME Section III; Subsection NB	Alloy X	See Appendix 1.A	NA	NA
Criticality Control	Basket Cell Plates	A	ASME Section III; Subsection NG core support structures (NG-1121)	Alloy X	See Appendix 1.A	NA	NA
Criticality Control	Neutron Absorber	A	Non-code	NA	NA	NA	Aluminum/SS
Shielding	Drain and Vent Shield Block	C	Non-code	Alloy X	See Appendix 1.A	NA	NA
Shielding	Plugs for Drilled Holes	NITS	Non-code	SA 193B8 (or equivalent)	See Appendix 1.A	NA	NA

- Notes:
- 1) There are no known residuals on finished component surfaces
  - 2) All welding processes used in welding the components shall be qualified in accordance with the requirements of ASME Section IX. All welds shall be made using welders qualified in accordance with ASME Section IX. Weld material shall meet the requirements of ASME Section II and the applicable Subsection of ASME Section III.
  - 3) Component nomenclature taken from Bill of Materials in Chapter 1.
  - 4) A, B, and C denote important to safety classifications as described in the Holtec QA Program. NITS stands for Not Important to Safety.
  - 5) For details on Alloy X material, see Appendix 1.A.
  - 6) Must be Type 304, 304LN, 316, or 316 LN with tensile strength  $\geq 75$  ksi, yield strength  $\geq 30$  ksi and chemical properties per ASTM A554.

HOLTEC INTERNATIONAL COPYRIGHTED MATERIAL

TABLE 2.2.6

MATERIALS AND COMPONENTS OF THE HI-STORM 100 SYSTEM  
MPC<sup>(1,2)</sup>

Primary Function	Component <sup>(3)</sup>	Safety Class <sup>(4)</sup>	Codes/Standards (as applicable to component)	Material	Strength (ksi)	Special Surface Finish/Coating	Contact Matl. (if dissimilar)
Shielding	Bottom portion of optional two-piece MPC lid design	B	Non-code	Alloy X	See Appendix 1.A	NA	NA
Structural Integrity	Upper Fuel Spacer Column	B	ASME Section III; Subsection NG (only for stress analysis)	Alloy X	See Appendix 1.A	NA	NA
Structural Integrity	Sheathing	A	Non-code	Alloy X	See Appendix 1.A	Aluminum/SS	NA
Structural Integrity	Shims	NITS	Non-code (shims, welded directly to angle or parallel plate basket supports, are ASME Section II)	Alloy X	See Appendix 1.A	NA	NA
Structural Integrity	Basket Supports (Angled Plate or Parallel Plates with connecting end shim)	A	ASME Section III; Subsection NG internal structures (NG-1122)	Alloy X	See Appendix 1.A	NA	NA
Structural Form	Basket Supports (Flat Plates)	NITS	Non-Code	Alloy X	See Appendix 1.A	NA	NA
Structural Integrity	Lift Lug	C	NUREG-0612	Alloy X	See Appendix 1.A	NA	NA
Structural Integrity	Lift Lug Baseplate	C	Non-code	Alloy X	See Appendix 1.A	NA	NA

- Notes:
- 1) There are no known residuals on finished component surfaces
  - 2) All welding processes used in welding the components shall be qualified in accordance with the requirements of ASME Section IX. All welds shall be made using welders qualified in accordance with ASME Section IX. Weld material shall meet the requirements of ASME Section II and the applicable Subsection of ASME Section III.
  - 3) Component nomenclature taken from Bill of Materials in Chapter 1.
  - 4) A, B, and C denote important to safety classifications as described in the Holtec QA Program. NITS stands for Not Important to Safety.
  - 5) For details on Alloy X material, see Appendix 1.A.
  - 6) Must be Type 304, 304LN, 316, or 316 LN with tensile strength  $\geq 75$  ksi, yield strength  $\geq 30$  ksi and chemical properties per ASTM A554.

HOLTEC INTERNATIONAL COPYRIGHTED MATERIAL

TABLE 2.2.6

MATERIALS AND COMPONENTS OF THE HI-STORM 100 SYSTEM  
MPC<sup>(1,2)</sup>

Primary Function	Component <sup>(3)</sup>	Safety Class <sup>(4)</sup>	Codes/Standards (as applicable to component)	Material	Strength (ksi)	Special Surface Finish/Coating	Contact Matl. (if dissimilar)
Structural Integrity	Upper Fuel Spacer Bolt	NITS	Non-code	A193-B8 (or equiv.)	Per ASME Section II	NA	NA
Structural Integrity	Upper Fuel Spacer End Plate	B	Non-code	Alloy X	See Appendix 1.A	NA	NA
Structural Integrity	Lower Fuel Spacer Column	B	ASME Section III; Subsection NG (only for stress analysis)	Stainless Steel. See Note 6	See Appendix 1.A	NA	NA
Structural Integrity	Lower Fuel Spacer End Plate	B	Non-code	Alloy X	See Appendix 1.A	NA	NA
Structural Integrity	Vent Shield Block Spacer	C	Non-code	Alloy X	See Appendix 1.A	NA	NA
Operations	Vent and Drain Tube	C	Non-code	S/S	Per ASME Section II	Thread area surface hardened	NA
Operations	Vent & Drain Cap	C	Non-code	S/S	Per ASME Section II	NA	NA
Operations	Vent & Drain Cap Seal Washer	NITS	Non-code	Aluminum	NA	NA	Aluminum/SS
Operations	Vent & Drain Cap Seal Washer Bolt	NITS	Non-code	Aluminum	NA	NA	NA
Operations	Reducer	NITS	Non-code	Alloy X	See Appendix 1.A	NA	NA
Operations	Drain Line	NITS	Non-code	Alloy X	See Appendix 1.A	NA	NA

- Notes:
- 1) There are no known residuals on finished component surfaces
  - 2) All welding processes used in welding the components shall be qualified in accordance with the requirements of ASME Section IX. All welds shall be made using welders qualified in accordance with ASME Section IX. Weld material shall meet the requirements of ASME Section II and the applicable Subsection of ASME Section III.
  - 3) Component nomenclature taken from Bill of Materials in Chapter 1.
  - 4) A, B, and C denote important to safety classifications as described in the Holtec QA Program. NITS stands for Not Important to Safety.
  - 5) For details on Alloy X material, see Appendix 1.A.
  - 6) Must be Type 304, 304LN, 316, or 316 LN with tensile strength  $\geq 75$  ksi, yield strength  $\geq 30$  ksi and chemical properties per ASTM A554.

TABLE 2.2.6

MATERIALS AND COMPONENTS OF THE HI-STORM 100 SYSTEM  
MPC<sup>(1,2)</sup>

Primary Function	Component <sup>(3)</sup>	Safety Class <sup>(4)</sup>	Codes/Standards (as applicable to component)	Material	Strength (ksi)	Special Surface Finish/Coating	Contact Matl. (if dissimilar)
Operations	Damaged Fuel Container	C	ASME Section III; Subsection NG	S/S (Primarily 304 S/S)	See Appendix 1.A	NA	NA
Operations	Drain Line Guide Tube	NITS	Non-code	S/S	NA	NA	NA

- Notes:
- 1) There are no known residuals on finished component surfaces
  - 2) All welding processes used in welding the components shall be qualified in accordance with the requirements of ASME Section IX. All welds shall be made using welders qualified in accordance with ASME Section IX. Weld material shall meet the requirements of ASME Section II and the applicable Subsection of ASME Section III.
  - 3) Component nomenclature taken from Bill of Materials in Chapter 1.
  - 4) A, B, and C denote important to safety classifications as described in the Holtec QA Program. NITS stands for Not Important to Safety.
  - 5) For details on Alloy X material, see Appendix 1.A.
  - 6) Must be Type 304, 304LN, 316, or 316 LN with tensile strength  $\geq 75$  ksi, yield strength  $\geq 30$  ksi and chemical properties per ASTM A554.

TABLE 2.2.6

MATERIALS AND COMPONENTS OF THE HI-STORM 100 SYSTEM  
OVERPACK<sup>(1,2)</sup>

Primary Function	Component <sup>(3)</sup>	Safety Class <sup>(4)</sup>	Codes/Standards (as applicable to component)	Material	Strength (ksi)	Special Surface Finish/Coating	Contact Matl. (if dissimilar)
Shielding	Radial Shield	B	ACI 349, App. 1.D	Concrete	See Table 1.D.1	NA	NA
Shielding	Shield Block Ring (100)	B	See Note 6	SA516-70	See Table 3.3.2	See Note 5	NA
Shielding	Lid Shield Ring (100S and 100S Version B) and Shield Block Shell (100S)	B	ASME Section III; Subsection NF	SA516-70 or SA515-70 (SA515-70 not permitted for 100S Version B)	See Table 3.3.2	See Note 5	NA
Shielding	Shield Block Shell (100)	B	See Note 6	SA516-70 or SA515-70	See Table 3.3.2	See Note 5	NA
Shielding	Pedestal Shield	B	ACI 349, App. 1-D	Concrete	See Table 1.D.1	NA	NA
Shielding	Lid Shield	B	ACI 349, App. 1-D	Concrete	See Table 1.D.1	NA	NA
Shielding	Shield Shell (eliminated from design 6/01)	B	See Note 6	SA516-70	See Table 3.3.2	NA	NA
Shielding	Shield Block	B	ACI 349, App. 1-D	Concrete	See Table 1.D.1	NA	NA
Shielding	Gamma Shield Cross Plates & Tabs	C	Non-code	SA240-304	NA	NA	NA

- Notes:
- 1) There are no known residuals on finished component surfaces
  - 2) All welding processes used in welding the components shall be qualified in accordance with the requirements of ASME Section IX. All welds shall be made using welders qualified in accordance with ASME Section IX. Weld material shall meet the requirements of ASME Section II and the applicable Subsection of ASME Section III.
  - 3) Component nomenclature taken from Bills of Material and drawings in Chapter 1. All components are "as applicable" based in the overpack drawing/BOM unless otherwise noted.
  - 4) A, B, and C denote important to safety classifications as described in the Holtec QA Program. NITS stands for Not Important to Safety.
  - 5) All exposed steel surfaces (except threaded holes) to be painted with Thermaline 450 or equivalent to the extent practical.
  - 6) Welds will meet AWS D1.1 requirements for prequalified welds, except that welder qualification and weld procedures of ASME Code Section IX may be substituted.

HOLTEC INTERNATIONAL COPYRIGHTED MATERIAL

TABLE 2.2.6

MATERIALS AND COMPONENTS OF THE HI-STORM 100 SYSTEM  
OVERPACK<sup>(1,2)</sup>

Primary Function	Component <sup>(3)</sup>	Safety Class <sup>(4)</sup>	Codes/Standards (as applicable to component)	Material	Strength (ksi)	Special Surface Finish/Coating	Contact Matl. (if dissimilar)
Structural Integrity	Baseplate	B	ASME Section III; Subsection NF	SA516-70	See Table 3.3.3	See Note 5	NA
Structural Integrity	Outer Shell	B	ASME Section III; Subsection NF	SA516-70	See Table 3.3.2	See Note 5	NA
Structural Integrity	Inner Shell	B	ASME Section III; Subsection NF	SA516-70	See Table 3.3.2	See Note 5	NA
Concrete Form	Pedestal Shell	B	See Note 6	SA516-70	See Table 3.3.2	See Note 5	NA
Concrete Form	Pedestal Plate (100) Pedestal Baseplate (100S)	B	See Note 6	SA516-70 or SA515-70	See Table 3.3.2	See Table 3.3.2	NA
Structural Integrity	Lid Bottom Plate	B	ASME Section III; Subsection NF	SA516-70	See Table 3.3.2	See Note 5	NA
Structural Integrity	Lid Shell	B	ASME Section III; Subsection NF	SA516-70	See Table 3.3.2	See Note 5	NA
Structural Integrity	Inlet Vent Vertical & Horizontal Plates	B	ASME Section III; Subsection NF	SA516-70	See Table 3.3.2	See Note 5	NA
Thermal	Exit Vent Horizontal Plate (100)	B	See Note 6	SA516-70	See Table 3.3.2	See Note 5	NA
Thermal	Exit Vent Vertical/Side Plate	B	See Note 6	SA516-70 or SA515-70	See Table 3.3.2	See Note 5	NA

- Notes:
- 1) There are no known residuals on finished component surfaces
  - 2) All welding processes used in welding the components shall be qualified in accordance with the requirements of ASME Section IX. All welds shall be made using welders qualified in accordance with ASME Section IX. Weld material shall meet the requirements of ASME Section II and the applicable Subsection of ASME Section III.
  - 3) Component nomenclature taken from Bills of Material and drawings in Chapter 1. All components are "as applicable" based in the overpack drawing/BOM unless otherwise noted.
  - 4) A, B, and C denote important to safety classifications as described in the Holtec QA Program. NITS stands for Not Important to Safety.
  - 5) All exposed steel surfaces (except threaded holes) to be painted with Thermaline 450 or equivalent to the extent practical.
  - 6) Welds will meet AWS D1.1 requirements for prequalified welds, except that welder qualification and weld procedures of ASME Code Section IX may be substituted.

TABLE 2.2.6

MATERIALS AND COMPONENTS OF THE HI-STORM 100 SYSTEM  
OVERPACK <sup>(1,2)</sup>

Primary Function	Component <sup>(3)</sup>	Safety Class <sup>(4)</sup>	Codes/Standards (as applicable to component)	Material	Strength (ksi)	Special Surface Finish/Coating	Contact Matl. (if dissimilar)
Thermal	Heat Shield	B	N/A	C/S	N/A	See Note 5	N/A
Thermal	Heat Shield Ring	B	N/A	C/S	N/A	See Note 5	N/A
Structural Integrity	Top Plate, including shear ring	B	ASME Section III; Subsection NF	SA516-70	See Table 3.3.2	See Note 5	NA
Structural Integrity	Lid Top (Cover) Plate, including shear ring (100 and 100S)	B	ASME Section III; Subsection NF	SA516-70	See Table 3.3.2	See Note 5	NA
Structural Integrity	Radial Plate	B	ASME Section III; Subsection NF	SA516-70	See Table 3.3.2	See Note 5	NA
Structural Integrity	Lid Stud & Nut	B	ASME Section II	SA564-630 or SA 193-B7 (stud) SA 194-2H (nut)	See Table 3.3.4	Threads to have cadmium coating (or similar lubricant for corrosion protection)	NA
Structural Integrity	100S Lid Washer	B	Non-Code	SA240-304	Per ASME Section II	NA	NA
Structural Integrity	Bolt Anchor Block	B	ASME Section III; Subsection NF ANSI N14.6	SA350-LF3, SA350-LF2, or SA203E	See Table 3.3.3	See Note 5	NA

- Notes:
- 1) There are no known residuals on finished component surfaces
  - 2) All welding processes used in welding the components shall be qualified in accordance with the requirements of ASME Section IX. All welds shall be made using welders qualified in accordance with ASME Section IX. Weld material shall meet the requirements of ASME Section II and the applicable Subsection of ASME Section III.
  - 3) Component nomenclature taken from Bills of Material and drawings in Chapter 1. All components are "as applicable" based in the overpack drawing/BOM unless otherwise noted.
  - 4) A, B, and C denote important to safety classifications as described in the Holtec QA Program. NITS stands for Not Important to Safety.
  - 5) All exposed steel surfaces (except threaded holes) to be painted with Thermaline 450 or equivalent to the extent practical.
  - 6) Welds will meet AWS D1.1 requirements for prequalified welds, except that welder qualification and weld procedures of ASME Code Section IX may be substituted.



TABLE 2.2.6

MATERIALS AND COMPONENTS OF THE HI-STORM 100 SYSTEM  
OVERPACK <sup>(1,2)</sup>

Primary Function	Component <sup>(3)</sup>	Safety Class <sup>(4)</sup>	Codes/Standards (as applicable to component)	Material	Strength (ksi)	Special Surface Finish/Coating	Contact Matl. (if dissimilar)
Structural Integrity	Channel	B	ASME Section III; Subsection NF	SA516-70 (galvanized) or SA240-304	See Table 3.3.2 or Table 3.3.1	See Note 5	NA
Structural Integrity	Channel Mounts	B	ASME Section III; Subsection NF	A36 or equivalent	Per ASME Section II	See Note 5	NA
Shielding	Pedestal Platform	B	Non-Code	A36 or equivalent	NA	See Note 5	NA
Operations	Storage Marking Nameplate	NITS	Non-code	SA240-304	NA	NA	NA
Operations	Exit Vent Screen Sheet	NITS	Non-code	SA240-304	NA	NA	NA
Operations	Drain Pipe	NITS	Non-code	C/S or S/S	NA	See Note 5	NA
Operations	Exit & Inlet Screen Frame	NITS	Non-code	SA240-304	NA	NA	NA
Operations	Temperature Element & Associated Temperature Monitoring Equipment	C	Non-code	NA	NA	NA	NA
Operations	Screen	NITS	Non-code	Mesh Wire	NA	NA	NA
Operations	Paint	NITS	Non-code	Thermaline 450 or equivalent	NA	NA	NA

- Notes:
- 1) There are no known residuals on finished component surfaces
  - 2) All welding processes used in welding the components shall be qualified in accordance with the requirements of ASME Section IX. All welds shall be made using welders qualified in accordance with ASME Section IX. Weld material shall meet the requirements of ASME Section II and the applicable Subsection of ASME Section III.
  - 3) Component nomenclature taken from Bills of Material and drawings in Chapter 1. All components are "as applicable" based in the overpack drawing/BOM unless otherwise noted.
  - 4) A, B, and C denote important to safety classifications as described in the Holtec QA Program. NITS stands for Not Important to Safety.
  - 5) All exposed steel surfaces (except threaded holes) to be painted with Thermaline 450 or equivalent to the extent practical.
  - 6) Welds will meet AWS D1.1 requirements for prequalified welds, except that welder qualification and weld procedures of ASME Code Section IX may be substituted.

TABLE 2.2.6

MATERIALS AND COMPONENTS OF THE HI-STORM 100 SYSTEM  
OVERPACK <sup>(1,2)</sup>

Primary Function	Component <sup>(3)</sup>	Safety Class <sup>(4)</sup>	Codes/Standards (as applicable to component)	Material	Strength (ksi)	Special Surface Finish/Coating	Contact Matl. (if dissimilar)
Structural Integrity	100S Version B Base Bottom Plate	B	ASME III; Subsection NF	Carbon Steel	See Table 3.3.6	See Note 5	NA
Structural Integrity	100S Version B Base Spacer Block	B	Non-code	Carbon Steel	NA	See Note 5	NA
Shielding	100S Version B Base Shield Block	B	Non-code	Carbon Steel	NA	See Note 5	NA
Structural Integrity	100S Version B Base Top Plate	B	ASME III; Subsection NF	SA 516-70	See Table 3.3.2	See Note 5	NA
Structural Integrity	100S Version B Base MPC Support	B	Non-code	SA36	NA	See Note 5	NA
Shielding	100S Version B Lid Outer Ring	B	ASME III; Subsection NF	SA516-70 or SA36	See Table 3.3.2 or Table 3.3.6	See Note 5	NA
Operations	100S Version B Lid Vent Duct	NITS	Non-code	Carbon Steel	NA	See Note 5	NA
Structural Integrity	100S Version B Lid Inner Ring	B	ASME III; Subsection NF	Carbon Steel	See Table 3.3.6	See Note 5	NA
Operations	100S Version B Lid Stud Pipe	NITS	Non-code	Carbon Steel	NA	See Note 5	NA
Operations	100S Version B Lid Stud Spacer	NITS	Non-code	Carbon Steel	NA	See Note 5	NA

- Notes:
- 1) There are no known residuals on finished component surfaces
  - 2) All welding processes used in welding the components shall be qualified in accordance with the requirements of ASME Section IX. All welds shall be made using welders qualified in accordance with ASME Section IX. Weld material shall meet the requirements of ASME Section II and the applicable Subsection of ASME Section III.
  - 3) Component nomenclature taken from Bills of Material and drawings in Chapter 1. All components are "as applicable" based in the overpack drawing/BOM unless otherwise noted.
  - 4) A, B, and C denote important to safety classifications as described in the Holtec QA Program. NITS stands for Not Important to Safety.
  - 5) All exposed steel surfaces (except threaded holes) to be painted with Thermaline 450 or equivalent to the extent practical.
  - 6) Welds will meet AWS D1.1 requirements for prequalified welds, except that welder qualification and weld procedures of ASME Code Section IX may be substituted.

TABLE 2.2.6

MATERIALS AND COMPONENTS OF THE HI-STORM 100 SYSTEM  
OVERPACK <sup>(1,2)</sup>

Primary Function	Component <sup>(3)</sup>	Safety Class <sup>(4)</sup>	Codes/Standards (as applicable to component)	Material	Strength (ksi)	Special Surface Finish/Coating	Contact Matl. (if dissimilar)
Operations	100S Version B Lid Lift Block	B	ASME III; Subsection NF	SA36	See Table 3.3.2	See Note 5	NA
Shielding	100S Version B Lid Vent Shield	B	Non-code	Carbon Steel	NA	See Note 5	NA
Operations	100S Version B Lid Stud Washer	C	Non-code	Stainless Steel	NA	See Note 5	NA
Operations	100S Version B Lid Stud Cap	NITS	Non-code	PVC	NA	See Note 5	NA
Structural Integrity	100S Version B Radial Gusset	B	ASME III; Subsection NF	SA 516-70	NA	See Note 5	NA
Structural Integrity	100S Version B Lid Closure Bolt and Closure Bolt Handle	B (bolt) NITS (bolt Handle)	ASME Section II	SA 193-B7 (bolt) C/S (bolt handle)	See Table 3.3.4 (bolt) NA (bolt handle)	Threads to have cadmium coating (or similar lubricant for corrosion protection)	NA
Structural Integrity	100S Version B Lid Top (Cover) Plate	B	ASME Section III; Subsection NF	SA516-70 or SA36	See Table 3.3.2 or Table 3.3.6	See Note 5	NA
Structural Integrity	100S Version B Shear Ring	B	ASME Section III; Subsection NF	SA516-70	See Table 3.3.2	See Note 5	NA

- Notes:
- 1) There are no known residuals on finished component surfaces
  - 2) All welding processes used in welding the components shall be qualified in accordance with the requirements of ASME Section IX. All welds shall be made using welders qualified in accordance with ASME Section IX. Weld material shall meet the requirements of ASME Section II and the applicable Subsection of ASME Section III.
  - 3) Component nomenclature taken from Bills of Material and drawings in Chapter 1. All components are "as applicable" based in the overpack drawing/BOM unless otherwise noted.
  - 4) A, B, and C denote important to safety classifications as described in the Holtec QA Program. NITS stands for Not Important to Safety.
  - 5) All exposed steel surfaces (except threaded holes) to be painted with Thermaline 450 or equivalent to the extent practical.
  - 6) Welds will meet AWS D1.1 requirements for prequalified welds, except that welder qualification and weld procedures of ASME Code Section IX may be substituted.

TABLE 2.2.6

MATERIALS AND COMPONENTS OF THE HI-STORM 100 SYSTEM  
HI-TRAC TRANSFER CASK <sup>(1,2)</sup>

Primary Function	Component <sup>(3)</sup>	Safety Class <sup>(4)</sup>	Codes/Standards (as applicable to component)	Material	Strength (ksi)	Special Surface Finish/Coating	Contact Matl. (if dissimilar)
Shielding	Radial Lead Shield	B	Non-code	Lead	NA	NA	NA
Shielding	Pool Lid Lead Shield	B	Non-code	Lead	NA	NA	NA
Shielding	Top Lid Shielding	B	Non-code	Holtite	NA	NA	NA
Shielding	Plugs for Lifting Holes	NITS	Non-code	C/S or S/S	NA	NA	
Structural Integrity	Outer Shell	B	ASME Section III; Subsection NF	SA516-70	See Table 3.3.2	See Note 5	NA
Structural Integrity	Inner Shell	B	ASME Section III; Subsection NF	SA516-70	See Table 3.3.2	See Note 5	NA
Structural Integrity	Radial Ribs	B	ASME Section III; Subsection NF	SA516-70	See Table 3.3.2	See Note 5	NA
Structural Integrity	Water Jacket Enclosure Shell Panels (HI-TRAC 100 and 125)	B	ASME Section III; Subsection NF	SA516-70	See Table 3.3.2	See Note 5	NA
Structural Integrity	Water Jacket Enclosure Shell Panels (HI-TRAC 100D and 125D)	B	ASME Section III; Subsection NF	SA516-70 or SA515-70	See Table 3.3.2	See Note 5	NA
Structural Integrity	Water Jacket End Plate	B	ASME Section III; Subsection NF	SA516-70	See Table 3.3.2	See Note 5	NA
Structural Integrity	Top Flange	B	ASME Section III; Subsection NF	SA350-LF3	See Table 3.3.3	See Note 5	NA
Structural Integrity	Lower Water Jacket Shell	B	ASME Section III; Subsection NF	SA516-70	See Table 3.3.2	See Note 5	NA

- Notes:
- 1) There are no known residuals on finished component surfaces
  - 2) All welding processes used in welding the components shall be qualified in accordance with the requirements of ASME Section IX. All welds shall be made using welders qualified in accordance with ASME Section IX. Weld material shall meet the requirements of ASME Section II and the applicable Subsection of ASME Section III.
  - 3) Component nomenclature taken from Bill of Materials in Chapter 1.
  - 4) A, B, and C denote important to safety classifications as described in the Holtec QA Program. NITS stands for Not Important to Safety.
  - 5) All external surfaces to be painted with Carboline 890. Top surface of doors to be painted with Thermaline 450.

HOLTEC INTERNATIONAL COPYRIGHTED MATERIAL

TABLE 2.2.6

MATERIALS AND COMPONENTS OF THE HI-STORM 100 SYSTEM  
HI-TRAC TRANSFER CASK <sup>(1,2)</sup>

Primary Function	Component <sup>(3)</sup>	Safety Class <sup>(4)</sup>	Codes/Standards (as applicable to component)	Material	Strength (ksi)	Special Surface Finish/Coating	Contact Matl. (if dissimilar)
Structural Integrity	Pool Lid Outer Ring	B	ASME Section III; Subsection NF	SA516-70 or SA 203E or SA350-LF3	See Table 3.3.3	See Note 5	NA
Structural Integrity	Pool Lid Top Plate	B	ASME Section III; Subsection NF	SA516-70	See Table 3.3.2	See Note 5	NA
Structural Integrity	Top Lid Outer Ring	B	ASME Section III; Subsection NF	SA516-70	See Table 3.3.2	See Note 5	NA
Structural Integrity	Top Lid Inner Ring	B	ASME Section III; Subsection NF	SA516-70	See Table 3.3.2	See Note 5	NA
Structural Integrity	Top Lid Top Plate	B	ASME Section III; Subsection NF	SA516-70	See Table 3.3.2	See Note 5	NA
Structural Integrity	Top Lid Bottom Plate	B	ASME Section III; Subsection NF	SA516-70	See Table 3.3.2	See Note 5	NA
Structural Integrity	Fill Port Plugs	C	ASME Section III; Subsection NF	Carbon Steel	See Table 3.3.2	See Note 5	NA

- Notes:
- 1) There are no known residuals on finished component surfaces
  - 2) All welding processes used in welding the components shall be qualified in accordance with the requirements of ASME Section IX. All welds shall be made using welders qualified in accordance with ASME Section IX. Weld material shall meet the requirements of ASME Section II and the applicable Subsection of ASME Section III.
  - 3) Component nomenclature taken from Bill of Materials in Chapter 1.
  - 4) A, B, and C denote important to safety classifications as described in the Holtec QA Program. NITS stands for Not Important to Safety.
  - 5) All external surfaces to be painted with Carboline 890. Top surface of doors to be painted with Thermaline 450.

HOLTEC INTERNATIONAL COPYRIGHTED MATERIAL

TABLE 2.2.6

MATERIALS AND COMPONENTS OF THE HI-STORM 100 SYSTEM  
HI-TRAC TRANSFER CASK <sup>(1,2)</sup>

Primary Function	Component <sup>(3)</sup>	Safety Class <sup>(4)</sup>	Codes/Standards (as applicable to component)	Material	Strength (ksi)	Special Surface Finish/Coating	Contact Matl. (if dissimilar)
Structural Integrity	Pool Lid Bolt	B	ASME Section III; Subsection NF	SA193-B7	See Table 3.3.4	NA	NA
Structural Integrity	Lifting Trunnion Block	B	ASME Section III; Subsection NF	SA350-LF3	See Table 3.3.3	See Note 5	NA
Structural Integrity	Lifting Trunnion	A	ANSI N14.6	SB637 (N07718)	See Table 3.3.4	NA	NA
Structural Integrity	Pocket Trunnion (HI-TRAC 100 and HI-TRAC 125 only)	B	ASME Section III; Subsection NF ANSI N14.6	SA350-LF3	See Table 3.3.3	See Note 5	NA
Structural Integrity	Dowel Pins	B	ASME Section III; Subsection NF	SA564-630	See Table 3.3.4	NA	SA350-LF3
Structural Integrity	Water Jacket End Plate	B	ASME Section III; Subsection NF	SA516-70	See Table 3.3.2	See Note 5	NA
Structural Integrity	Pool Lid Bottom Plate	B	ASME Section III; Subsection NF	SA516-70	See Table 3.3.2	See Note 5	NA
Structural Integrity	Top Lid Lifting Block	C	ASME Section III; Subsection NF	SA516-70	See Table 3.3.2	See Note 5	NA
Structural Integrity	Bottom Flange Gussets (HI-TRAC 100D and 125D only)	B	ASME Section III; Subsection NF	SA516-70	See Table 3.3.2	See Note 5	NA
Operations	Top Lid Stud or bolt	B	ASME Section III; Subsection NF	SA193-B7	See Table 3.3.4	NA	NA

- Notes:
- 1) There are no known residuals on finished component surfaces
  - 2) All welding processes used in welding the components shall be qualified in accordance with the requirements of ASME Section IX. All welds shall be made using welders qualified in accordance with ASME Section IX. Weld material shall meet the requirements of ASME Section II and the applicable Subsection of ASME Section III.
  - 3) Component nomenclature taken from Bill of Materials in Chapter 1.
  - 4) A, B, and C denote important to safety classifications as described in the Holtec QA Program. NITS stands for Not Important to Safety.
  - 5) All external surfaces to be painted with Carboline 890. Top surface of doors to be painted with Thermaline 450.

HOLTEC INTERNATIONAL COPYRIGHTED MATERIAL

TABLE 2.2.6

MATERIALS AND COMPONENTS OF THE HI-STORM 100 SYSTEM  
HI-TRAC TRANSFER CASK <sup>(1,2)</sup>

Primary Function	Component <sup>(3)</sup>	Safety Class <sup>(4)</sup>	Codes/Standards ( as applicable to component)	Material	Strength ( ksi)	Special Surface Finish/Coating	Contact Matl. ( if dissimilar)
Operations	Top Lid Nut	B	ASME Section III; Subsection NF	SA194-2H	NA	NA	NA
Operations	Pool Lid Gasket	NITS	Non-code	Elastomer	NA	NA	NA
Operations	Lifting Trunnion End Cap (HI-TRAC 100 and HI-TRAC 125 only)	C	Non-code	SA516-70	See Table 3.3.2	See Note 5	NA
Operations	End Cap Bolts (HI-TRAC 100 and HI-TRAC 125 only)	NITS	Non-code	SA193-B7	See Table 3.3.4	NA	NA
Operations	Drain Pipes	NITS	Non-code	SA106	NA	NA	NA
Operations	Drain Bolt	NITS	Non-code	SA193-B7	See Table 3.3.4	NA	NA
Operations	Couplings, Valves and Vent Plug	NITS	Non-code	Commercial	NA	NA	NA

- Notes:
- 1) There are no known residuals on finished component surfaces
  - 2) All welding processes used in welding the components shall be qualified in accordance with the requirements of ASME Section IX. All welds shall be made using welders qualified in accordance with ASME Section IX. Weld material shall meet the requirements of ASME Section II and the applicable Subsection of ASME Section III.
  - 3) Component nomenclature taken from Bill of Materials in Chapter 1.
  - 4) A, B, and C denote important to safety classifications as described in the Holtec QA Program. NITS stands for Not Important to Safety.
  - 5) All external surfaces to be painted with Carboline 890. Top surface of doors to be painted with Thermaline 450.

HOLTEC INTERNATIONAL COPYRIGHTED MATERIAL

TABLE 2.2.6

MATERIALS AND COMPONENTS OF THE HI-STORM 100 SYSTEM  
 HI-TRAC TRANSFER LID (HI-TRAC 100 and HI-TRAC 125 ONLY)<sup>(1,2)</sup>

Primary Function	Component <sup>(3)</sup>	Safety Class <sup>(4)</sup>	Codes/Standards (as applicable to component)	Material	Strength (ksi)	Special Surface Finish/Coating	Contact Matl. (if dissimilar)
Shielding	Side Lead Shield	B	Non-code	Lead	NA	NA	NA
Shielding	Door Lead Shield	B	Non-code	Lead	NA	NA	
Shielding	Door Shielding	B	Non-code	Holtite	NA	NA	NA
Structural Integrity	Lid Top Plate	B	ASME Section III; Subsection NF	SA516-70	See Table 3.3.2	See Note 5	NA
Structural Integrity	Lid Bottom Plate	B	ASME Section III; Subsection NF	SA516-70	See Table 3.3.2	See Note 5	NA
Structural Integrity	Lid Intermediate Plate	B	ASME Section III; Subsection NF	SA516-70	See Table 3.3.2	See Note 5	NA
Structural Integrity	Lead Cover Plate	B	ASME Section III; Subsection NF	SA516-70	See Table 3.3.2	See Note 5	NA
Structural Integrity	Lead Cover Side Plate	B	ASME Section III; Subsection NF	SA516-70	See Table 3.3.2	See Note 5	NA
Structural Integrity	Door Top Plate	B	ASME Section III; Subsection NF	SA516-70	See Table 3.3.2	See Note 5	NA
Structural Integrity	Door Middle Plate	B	ASME Section III; Subsection NF	SA516-70	See Table 3.3.2	See Note 5	NA
Structural Integrity	Door Bottom Plate	B	ASME Section III; Subsection NF	SA516-70	See Table 3.3.2	See Note 5	NA
Structural Integrity	Door Wheel Housing	B	ASME Section III; Subsection NF	SA516-70 (SA350-LF3)	See Table 3.3.2 (Table 3.3.3)	See Note 5	NA
Structural Integrity	Door Interface Plate	B	ASME Section III; Subsection NF	SA516-70	See Table 3.3.2	See Note 5	NA

- Notes:
- 1) There are no known residuals on finished component surfaces
  - 2) All welding processes used in welding the components shall be qualified in accordance with the requirements of ASME Section IX. All welds shall be made using welders qualified in accordance with ASME Section IX. Weld material shall meet the requirements of ASME Section II and the applicable Subsection of ASME Section III.
  - 3) Component nomenclature taken from Bill of Materials in Chapter 1.
  - 4) A, B, and C denote important to safety classifications as described in the Holtec QA Program. NITS stands for Not Important to Safety.
  - 5) All external surfaces to be painted with Carboline 890. Top surface of doors to be painted with Thermaline 450.

HOLTEC INTERNATIONAL COPYRIGHTED MATERIAL



TABLE 2.2.6

MATERIALS AND COMPONENTS OF THE HI-STORM 100 SYSTEM  
 HI-TRAC TRANSFER LID (HI-TRAC 100 and HI-TRAC 125 ONLY)<sup>(1,2)</sup>

Primary Function	Component <sup>(3)</sup>	Safety Class <sup>(4)</sup>	Codes/Standards (as applicable to component)	Material	Strength (ksi)	Special Surface Finish/Coating	Contact Matl. (if dissimilar)
Structural Integrity	Door Side Plate	B	ASME Section III; Subsection NF	SA516-70	See Table 3.3.2	See Note 5	NA
Structural Integrity	Wheel Shaft	C	ASME Section III; Subsection NF	SA 193-B7	36 (yield)	See Note 5	NA
Structural Integrity	Lid Housing Stiffener	B	ASME Section III; Subsection NF	SA516-70	See Table 3.3.2	See Note 5	NA
Structural Integrity	Door Lock Bolt	B	ASME Section III; Subsection NB	SA193-B7	See Table 3.3.4	NA	NA
Structural Integrity	Door End Plate	B	ASME Section III; Subsection NF	SA516-70	See Table 3.3.2	See Note 5	NA
Structural Integrity	Lifting Lug and Pad	B	ASME Section III; Subsection NF	SA516-70	See Table 3.3.2	See Note 5	NA
Operations	Wheel Track	C	ASME Section III; Subsection NF	SA-36	36 (yield)	See Note 5	NA
Operations	Door Handle	NITS	Non-code	C/S or S/S	NA	See Note 5	NA
Operations	Door Wheels	NITS	Non-code	Forged Steel	NA	NA	NA
Operations	Door Stop Block	C	Non-code	SA516-70	See Table 3.3.2	See Note 5	NA
Operations	Door Stop Block Bolt	C	Non-code	SA193-B7	See Table 3.3.4	NA	NA

- Notes:
- 1) There are no known residuals on finished component surfaces
  - 2) All welding processes used in welding the components shall be qualified in accordance with the requirements of ASME Section IX. All welds shall be made using welders qualified in accordance with ASME Section IX. Weld material shall meet the requirements of ASME Section II and the applicable Subsection of ASME Section III.
  - 3) Component nomenclature taken from Bill of Materials in Chapter 1.
  - 4) A, B, and C denote important to safety classifications as described in the Holtec QA Program. NITS stands for Not Important to Safety.
  - 5) All external surfaces to be painted with Carboline 890. Top surface of doors to be painted with Thermaline 450.

---

HOLTEC INTERNATIONAL COPYRIGHTED MATERIAL

Table 2.2.7

## HI-STORM 100 ASME BOILER AND PRESSURE VESSEL CODE APPLICABILITY

HI-STORM 100 Component	Material Procurement	Design	Fabrication	Inspection
Overpack steel structure	Section II, Section III, Subsection NF, NF-2000	Section III, Subsection NF, NF-3200	Section III, Subsection NF, NF-4000	Section III, Subsection NF, NF-5350, NF-5360 and Section V
Anchor Studs for HI-STORM 100A	Section II, Section III, Subsection NF, NF-2000*	Section III, Subsection NF, NF-3300	NA	NA
MPC confinement boundary	Section II, Section III, Subsection NB, NB-2000	Section III, Subsection NB, NB-3200	Section III, Subsection NB, NB-4000	Section III, Subsection NB, NB-5000 and Section V
MPC fuel basket	Section II, Section III, Subsection NG, NG-2000; core support structures (NG-1121)	Section III, Subsection NG, NG-3300 and NG-3200; core support structures (NG-1121)	Section III, Subsection NG, NG-4000; core support structures (NG-1121)	Section III, Subsection NG, NG-5000 and Section V; core support structures (NG-1121)
HI-TRAC Trunnions	Section II, Section III, Subsection NF, NF-2000	ANSI 14.6	Section III, Subsection NF, NF-4000	See Chapter 9
MPC basket supports (Angled Plates)	Section II, Section III, Subsection NG, NG-2000; internal structures (NG-1122)	Section III, Subsection NG, NG-3300 and NG-3200; internal structures (NG-1122)	Section III, Subsection NG, NG-4000; internal structures (NG-1122)	Section III, Subsection NG, NG-5000 and Section V; internal structures (NG-1122)
HI-TRAC steel structure	Section II, Section III, Subsection NF, NF-2000	Section III, Subsection NF, NF-3300	Section III, Subsection NF, NF-4000	Section III, Subsection NF, NF-5360 and Section V
Damaged fuel container	Section II, Section III, Subsection NG, NG-2000	Section III, Subsection NG, NG-3300 and NG-3200	Section III, Subsection NG, NG-4000	Section III, Subsection NG, NG-5000 and Section V
Overpack concrete	ACI 349 as specified by Appendix I.D	ACI 349 and ACI 318-95 as specified by Appendix I.D	ACI 349 as specified by Appendix I.D	ACI 349 as specified by Appendix I.D

\* Except impact testing shall be determined based on service temperature and material type.

HOLTEC INTERNATIONAL COPYRIGHTED MATERIAL

Table 2.2.8

ADDITIONAL DESIGN INPUT DATA FOR NORMAL, OFF-NORMAL, AND  
ACCIDENT CONDITIONS

Item	Condition	Value
Snow Pressure Loading (lb./ft <sup>2</sup> )	Normal	100
Constriction of MPC Basket Vent Opening By Crud Settling (Depth of Crud, in.)	Accident	0.85 (MPC-68) 0.36 (MPC-24 and MPC-32)
Cask Environment During the Postulated Fire Event (Deg. F)	Accident	1475
HI-STORM Overpack Fire Duration (seconds)	Accident	217
HI-TRAC Transfer Cask Fire Duration (minutes)	Accident	4.8
Maximum submergence depth due to flood (ft)	Accident	125
Flood water velocity (ft/s)	Accident	15
Interaction Relation for Horizontal & Vertical acceleration for HI-STORM	Accident	$G_H + 0.53G_V = 0.53^{\dagger\dagger}$ (HI-STORM 100, 100S, and 100S Version B)  $G_H = 2.12; G_V = 1.5$ (HI-STORM 100A)
Net Overturning Moment at base of HI-STORM 100A (ft-lb)	Accident	$18.7 \times 10^6$
HI-STORM 100 Overpack Vertical Lift Height Limit (in.)	Accident	$11^{\dagger\dagger\dagger}$ (HI-STORM 100 and 100S), OR By Users (HI-STORM 100A)
HI-TRAC Transfer Cask Horizontal Lift Height Limit (in.)	Accident	$42^{\dagger\dagger\dagger}$

<sup>††</sup> See Subsection 3.4.7.1 for definition of  $G_H$  and  $G_V$ . The coefficient of friction may be increased above 0.53 based on testing described in Subsection 3.4.7.1

<sup>†††</sup> For ISFSI and subgrade design parameter Sets A and B. Users may also develop a site-specific lift height limit.

Table 2.2.9

EXAMPLES OF ACCEPTABLE ISFSI PAD DESIGN PARAMETERS

PARAMETER	PARAMETER SET "A" †	PARAMETER SET "B"
Concrete thickness, $t_p$ , (inches)	$\leq 36$	$\leq 28$
Concrete Compressive Strength (at 28 days), $f_c'$ , (psi)	$\leq 4,200$	$\leq 6,000$ psi
Reinforcement Top and Bottom (both directions)	Reinforcing bar shall be 60 ksi Yield Strength ASTM Material	Reinforcing bar shall be 60 ksi Yield Strength ASTM Material
Subgrade Effective Modulus of Elasticity <sup>††</sup> (measured prior to ISFSI pad installation), E, (psi)	$\leq 28,000$	$\leq 16,000$

NOTE: A static coefficient of friction of 0.53 between the ISFSI pad and the bottom of the overpack shall be used. If for a specific ISFSI a higher value of the coefficient of friction is used, it shall be verified by test. The test procedure shall follow the guidelines included in the Sliding Analysis in Subsection 3.4.7.1.

† The characteristics of this pad are identical to the pad considered by Lawrence Livermore Laboratory (see Appendix 3.A).

†† An acceptable method of defining the soil effective modulus of elasticity applicable to the drop and tipover analysis is provided in Table 13 of NUREG/CR-6608 with soil classification in accordance with ASTM-D2487 Standard Classification of Soils for Engineering Purposes (Unified Soil Classification System USCS) and density determination in accordance with ASTM-D1586 Standard Test Method for Penetration Test and Split/Barrel Sampling of Soils.

Table 2.2.10  
MPC CONFINEMENT BOUNDARY STRESS INTENSITY LIMITS  
FOR DIFFERENT LOADING CONDITIONS (ELASTIC ANALYSIS PER NB-3220)<sup>†</sup>

STRESS CATEGORY	DESIGN	LEVELS A & B	LEVEL D <sup>††</sup>
Primary Membrane, $P_m$	$S_m$	N/A <sup>†††</sup>	AMIN ( $2.4S_m, .7S_u$ )
Local Membrane, $P_L$	$1.5S_m$	N/A	150% of $P_m$ Limit
Membrane plus Primary Bending	$1.5S_m$	N/A	150% of $P_m$ Limit
Primary Membrane plus Primary Bending	$1.5S_m$	N/A	150% of $P_m$ Limit
Membrane plus Primary Bending plus Secondary	N/A	$3S_m$	N/A
Average Shear Stress <sup>†††</sup>	$0.6S_m$	$0.6S_m$	$0.42S_u$

<sup>†</sup> Stress combinations including F (peak stress) apply to fatigue evaluations only.

<sup>††</sup> Governed by Appendix F, Paragraph F-1331 of the ASME Code, Section III.

<sup>†††</sup> No Specific stress limit applicable.

<sup>††††</sup> Governed by NB-3227.2 or F-1331.1(d).

Table 2.2.11

MPC BASKET STRESS INTENSITY LIMITS  
FOR DIFFERENT LOADING CONDITIONS (ELASTIC ANALYSIS PER NG-3220)

<b>STRESS CATEGORY</b>	<b>DESIGN</b>	<b>LEVELS A &amp; B</b>	<b>LEVEL D<sup>†</sup></b>
Primary Membrane, $P_m$	$S_m$	$S_m$	AMIN ( $2.4S_m$ , $.7S_u$ ) <sup>††</sup>
Primary Membrane plus Primary Bending	$1.5S_m$	$1.5S_m$	150% of $P_m$ Limit
Primary Membrane plus Primary Bending plus Secondary	N/A <sup>†††</sup>	$3S_m$	N/A

<sup>†</sup> Governed by Appendix F, Paragraph F-1331 of the ASME Code, Section III.

<sup>††</sup> Governed by NB-3227.2 or F-1331.1(d).

<sup>†††</sup> No specific stress intensity limit applicable.

Table 2.2.12  
 STRESS LIMITS FOR DIFFERENT  
 LOADING CONDITIONS FOR THE STEEL STRUCTURE OF THE OVERPACK AND HI-TRAC  
 (ELASTIC ANALYSIS PER NF-3260)

STRESS CATEGORY	DESIGN + LEVEL A	SERVICE CONDITION	
		LEVEL B	LEVEL D <sup>†</sup>
Primary Membrane, $P_m$	S	1.33S	AMAX ( $1.2S_y$ , $1.5S_m$ ) but $< .7S_u$
Primary Membrane, $P_m$ , plus Primary Bending, $P_b$	1.5S	1.995S	150% of $P_m$
Shear Stress (Average)	0.6S	0.6S	$< 0.42S_u$

Definitions:

S = Allowable Stress Value for Table 1A, ASME Section II, Part D.

$S_m$  = Allowable Stress Intensity Value from Table 2A, ASME Section II, Part D

$S_u$  = Ultimate Strength

<sup>†</sup> Governed by Appendix F, Paragraph F-1332 of the ASME Code, Section III.

Table 2.2.13

NOTATION FOR DESIGN LOADINGS FOR NORMAL, OFF-NORMAL, AND ACCIDENT CONDITIONS

NORMAL CONDITION	
LOADING	NOTATION
Dead Weight	D
Handling Loads	H
Design Pressure (Internal)	$P_i$
Design Pressure (External) <sup>†</sup>	$P_o$
Snow	S
Operating Temperature	T
OFF-NORMAL CONDITION	
Loading	Notation
Off-Normal Pressure (Internal)	$P_i'$
Off-Normal Pressure (External) <sup>†</sup>	$P_o$
Off-Normal Temperature	$T'$
Off-Normal HI-TRAC Handling	$H'$



Table 2.2.13 (continued)

NOTATION FOR DESIGN LOADINGS FOR NORMAL, OFF-NORMAL, AND ACCIDENT CONDITIONS

ACCIDENT CONDITIONS	
LOADING	NOTATION
Handling Accident	H'
Earthquake	E
Fire	T*
Tornado Missile	M
Tornado Wind	W'
Flood	F
Explosion	E*
Accident Pressure (Internal)	P <sub>i</sub> *
Accident Pressure (External)	P <sub>o</sub> *

Table 2.2.14  
 APPLICABLE LOAD CASES AND COMBINATIONS FOR EACH CONDITION AND COMPONENT<sup>†, ††</sup>

CONDITION	LOADING CASE	MPC	OVERPACK	HI-TRAC
Design (ASME Code Pressure Compliance)	1	$P_i, P_o$	N/A	N/A
Normal (Level A)	1	$D, T, H, P_i$	$D, T, H$	$D, T^{†††}, H, P_{i \text{ (water jacket)}}$
	2	$D, T, H, P_o$	N/A	N/A
Off-Normal (Level B)	1	$D, T', H, P_i'$	$D, T', H$	$N/A^{†††}$ (H' pocket trunnion)
	2	$D, T', H, P_o$	N/A	N/A
Accident (Level D)	1	$D, T, P_i, H'$	$D, T, H'$	$D, T, H'$
	2	$D, T^*, P_i^*$	N/A	N/A
	3	$D, T, P_o^{††††}$	$D, T, P_o^{††††}$	$D, T, P_o^{††††}$
	4	N/A	$D, T, (E, M, F, W')^{††††}$	$D, T, (M, W')^{††††}$

<sup>†</sup> The loading notations are given in Table 2.2.13. Each symbol represents a loading type and may have different values for different components. The different loads are assumed to be additive and applied simultaneously.

<sup>††</sup> N/A stands for "Not Applicable."

<sup>†††</sup> T (normal condition) for the HI-TRAC is 100°F and  $P_{i \text{ (water jacket)}}$  is 60 psig and, therefore, there is no off-normal temperature or load combination because Load Case 1, Normal (Level A), is identical to Load Case 1, Off-Normal (Level B). Only the off-normal handling load on the pocket trunnion is analyzed separately.

<sup>††††</sup>  $P_o^*$  bounds the external pressure due to explosion.

<sup>†††††</sup> (E, M, F, W') means loads are considered separately in combination with D, T. E and F not applicable to HI-TRAC.

Table 2.2.15

LIST OF ASME CODE EXCEPTIONS FOR HI-STORM 100 SYSTEM

<b>Component</b>	<b>Reference ASME Code Section/Article</b>	<b>Code Requirement</b>	<b>Exception, Justification &amp; Compensatory Measures</b>
<p>MPC, MPC basket assembly, HI-STORM overpack steel structure, and HI-TRAC transfer cask steel structure.</p>	<p>Subsection NCA</p>	<p>General Requirements. Requires preparation of a Design Specification, Design Report, Overpressure Protection Report, Certification of Construction Report, Data Report, and other administrative controls for an ASME Code stamped vessel.</p>	<p>Because the MPC, overpack, and transfer cask are not ASME Code stamped vessels, none of the specifications, reports, certificates, or other general requirements specified by NCA are required. In lieu of a Design Specification and Design Report, the HI-STORM FSAR includes the design criteria, service conditions, and load combinations for the design and operation of the HI-STORM 100 System as well as the results of the stress analyses to demonstrate that applicable Code stress limits are met. Additionally, the fabricator is not required to have an ASME-certified QA program. All important-to-safety activities are governed by the NRC-approved Holtec QA program.</p> <p>Because the cask components are not certified to the Code, the terms "Certificate Holder" and "Inspector" are not germane to the manufacturing of NRC-certified cask components. To eliminate ambiguity, the responsibilities assigned to the Certificate Holder in the various articles of Subsections NB, NG, and NF of the Code, as applicable, shall be interpreted to apply to the NRC Certificate of Compliance (CoC) holder (and by extension, to the component fabricator) if the requirement must be fulfilled. The Code term "Inspector" means the QA/QC personnel of the CoC holder and its vendors assigned to oversee and inspect the manufacturing process.</p>

Table 2.2.15 (continued)

## LIST OF ASME CODE EXCEPTIONS FOR HI-STORM 100 SYSTEM

Component	Reference ASME Code Section/Article	Code Requirement	Exception, Justification & Compensatory Measures
MPC	NB-1100	Statement of requirements for Code stamping of components.	MPC enclosure vessel is designed and will be fabricated in accordance with ASME Code, Section III, Subsection NB to the maximum practical extent, but Code stamping is not required.
MPC basket supports and lift lugs	NB-1130	<p>NB-1132.2(d) requires that the first connecting weld of a nonpressure-retaining structural attachment to a component shall be considered part of the component unless the weld is more than <math>2t</math> from the pressure-retaining portion of the component, where <math>t</math> is the nominal thickness of the pressure-retaining material.</p> <p>NB-1132.2(e) requires that the first connecting weld of a welded nonstructural attachment to a component shall conform to NB-4430 if the connecting weld is within <math>2t</math> from the pressure-retaining portion of the component.</p>	The MPC basket supports (nonpressure-retaining structural attachment) and lift lugs (nonstructural attachments (relative to the function of lifting a loaded MPC) that are used exclusively for lifting an empty MPC) are welded to the inside of the pressure-retaining MPC shell, but are not designed in accordance with Subsection NB. The basket supports and associated attachment welds are designed to satisfy the stress limits of Subsection NG and the lift lugs and associated attachment welds are designed to satisfy the stress limits of Subsection NF, as a minimum. These attachments and their welds are shown by analysis to meet the respective stress limits for their service conditions. Likewise, non-structural items, such as shield plugs, spacers, etc. if used, can be attached to pressure-retaining parts in the same manner.

Table 2.2.15 (continued)

## LIST OF ASME CODE EXCEPTIONS FOR HI-STORM 100 SYSTEM

Component	Reference ASME Code Section/Article	Code Requirement	Exception, Justification & Compensatory Measures
MPC	NB-2000	Requires materials to be supplied by ASME-approved material supplier.	Materials will be supplied by Holtec approved suppliers with Certified Material Test Reports (CMTRs) in accordance with NB-2000 requirements.
MPC, MPC basket assembly, HI-STORM overpack, and HI-TRAC transfer cask	NB-3100 NG-3100 NF-3100	Provides requirements for determining design loading conditions, such as pressure, temperature, and mechanical loads.	These requirements are not applicable. The HI-STORM FSAR, serving as the Design Specification, establishes the service conditions and load combinations for the storage system.
MPC	NB-3350	NB-3352.3 requires, for Category C joints, that the minimum dimensions of the welds and throat thickness shall be as shown in Figure NB-4243-1.	<p>Due to MPC basket-to-shell interface requirements, the MPC shell-to-baseplate weld joint design (designated Category C) does not include a reinforcing fillet weld or a bevel in the MPC baseplate, which makes it different than any of the representative configurations depicted in Figure NB-4243-1. The transverse thickness of this weld is equal to the thickness of the adjoining shell (1/2 inch). The weld is designed as a full penetration weld that receives VT and RT or UT, as well as final surface PT examinations. Because the MPC shell design thickness is considerably larger than the minimum thickness required by the Code, a reinforcing fillet weld that would intrude into the MPC cavity space is not included. Not including this fillet weld provides for a higher quality radiographic examination of the full penetration weld.</p> <p>From the standpoint of stress analysis, the fillet weld serves to reduce the local bending stress (secondary stress) produced by the gross structural discontinuity defined by the flat plate/shell junction. In the MPC design, the shell and baseplate thicknesses are well beyond that required to meet their respective membrane stress intensity limits.</p>

Table 2.2.15 (continued)

## LIST OF ASME CODE EXCEPTIONS FOR HI-STORM 100 SYSTEM

Component	Reference ASME Code Section/Article	Code Requirement	Exception, Justification & Compensatory Measures
MPC, MPC basket assembly, HI-STORM overpack steel structure, and HI-TRAC transfer cask steel structure	NB-4120 NG-4120 NF-4120	NB-4121.2, NG-4121.2, and NF-4121.2 provide requirements for repetition of tensile or impact tests for material subjected to heat treatment during fabrication or installation.	<p>In-shop operations of short duration that apply heat to a component, such as plasma cutting of plate stock, welding, machining, coating, and pouring of lead are not, unless explicitly stated by the Code, defined as heat treatment operations.</p> <p>For the steel parts in the HI-STORM 100 System components, the duration for which a part exceeds the off-normal temperature limit defined in Chapter 2 of the FSAR shall be limited to 24 hours in a particular manufacturing process (such as the HI-TRAC lead pouring process).</p>
MPC, HI-STORM overpack steel structure, HI-TRAC transfer cask steel structure	NB-4220 NF-4220	Requires certain forming tolerances to be met for cylindrical, conical, or spherical shells of a vessel.	<p>The cylindricity measurements on the rolled shells are not specifically recorded in the shop travelers, as would be the case for a Code-stamped pressure vessel. Rather, the requirements on inter-component clearances (such as the MPC-to-transfer cask) are guaranteed through fixture-controlled manufacturing. The fabrication specification and shop procedures ensure that all dimensional design objectives, including inter-component annular clearances are satisfied. The dimensions required to be met in fabrication are chosen to meet the functional requirements of the dry storage components. Thus, although the post-forming Code cylindricity requirements are not evaluated for compliance directly, they are indirectly satisfied (actually exceeded) in the final manufactured components.</p>

Table 2.2.15 (continued)

## LIST OF ASME CODE EXCEPTIONS FOR HI-STORM 100 SYSTEM

Component	Reference ASME Code Section/Article	Code Requirement	Exception, Justification & Compensatory Measures
MPC Lid and Closure Ring Welds	NB-4243	Full penetration welds required for Category C Joints (flat head to main shell per NB-3352.3)	MPC lid and closure ring are not full penetration welds. They are welded independently to provide a redundant seal. Additionally, a weld efficiency factor of 0.45 has been applied to the analyses of these welds.
MPC Closure Ring, Vent and Drain Cover Plate Welds	NB-5230	Radiographic (RT) or ultrasonic (UT) examination required.	Root (if more than one weld pass is required) and final liquid penetrant examination to be performed in accordance with NB-5245. The closure ring provides independent redundant closure for vent and drain cover plates.
MPC Lid to Shell Weld	NB-5230	Radiographic (RT) or ultrasonic (UT) examination required.	Only UT or multi-layer liquid penetrant (PT) examination is permitted. If PT examination alone is used, at a minimum, it will include the root and final weld layers and each approx. 3/8" of weld depth.
MPC Enclosure Vessel and Lid	NB-6111	All completed pressure retaining systems shall be pressure tested.	<p>The MPC vessel is seal welded in the field following fuel assembly loading. The MPC vessel shall then be pressure tested as defined in Chapter 9. Accessibility for leakage inspections preclude a Code compliant pressure test. All MPC vessel welds (except closure ring and vent/drain cover plate) are inspected by volumetric examination, except the MPC lid-to-shell weld shall be verified by volumetric or multi-layer PT examination. If PT alone is used, at a minimum, it must include the root and final layers and each approximately 3/8 inch of weld depth. For either UT or PT, the maximum undetectable flaw size must be determined in accordance with ASME Section XI methods. The critical flaw size shall not cause the primary stress limits of NB-3000 to be exceeded.</p> <p>The inspection results, including relevant findings (indications) shall be made a permanent part of the user's records by video, photographic, or other means which provide an equivalent record of weld integrity. The video or</p>

Table 2.2.15 (continued)

## LIST OF ASME CODE EXCEPTIONS FOR HI-STORM 100 SYSTEM

Component	Reference ASME Code Section/Article	Code Requirement	Exception, Justification & Compensatory Measures
			photographic records should be taken during the final interpretation period described in ASME Section V, Article 6, T-676. The vent/drain cover plate and the closure ring welds are confirmed by liquid penetrant examination. The inspection of the weld must be performed by qualified personnel and shall meet the acceptance requirements of ASME Code Section III, NB-5350 for PT or NB-5332 for UT.
MPC Enclosure Vessel	NB-7000	Vessels are required to have overpressure protection.	No overpressure protection is provided. Function of MPC enclosure vessel is to contain radioactive contents under normal, off-normal, and accident conditions of storage. MPC vessel is designed to withstand maximum internal pressure considering 100% fuel rod failure and maximum accident temperatures.
MPC Enclosure Vessel	NB-8000	States requirements for nameplates, stamping and reports per NCA-8000.	The HI-STORM 100 System is to be marked and identified in accordance with 10CFR71 and 10CFR72 requirements. Code stamping is not required. QA data package to be in accordance with Holtec approved QA program.
MPC Basket Assembly	NG-2000	Requires materials to be supplied by ASME approved Material Supplier.	Materials will be supplied by Holtec approved supplier with CMTRs in accordance with NG-2000 requirements.



Table 2.2.15 (continued)

## LIST OF ASME CODE EXCEPTIONS FOR HI-STORM 100 SYSTEM

Component	Reference ASME Code Section/Article	Code Requirement	Exception, Justification & Compensatory Measures
MPC Basket Assembly	NG-4420	NG-4427(a) requires a fillet weld in any single continuous weld may be less than the specified fillet weld dimension by not more than 1/16 inch, provided that the total undersize portion of the weld does not exceed 10 percent of the length of the weld. Individual undersize weld portions shall not exceed 2 inches in length.	<p>Modify the Code requirement (intended for core support structures) with the following text prepared to accord with the geometry and stress analysis imperatives for the fuel basket: For the longitudinal MPC basket fillet welds, the following criteria apply: 1) The specified fillet weld throat dimension must be maintained over at least 92 percent of the total weld length. All regions of undersized weld must be less than 3 inches long and separated from each other by at least 9 inches. 2) Areas of undercuts and porosity beyond that allowed by the applicable ASME Code shall not exceed 1/2 inch in weld length. The total length of undercut and porosity over any 1-foot length shall not exceed 2 inches. 3) The total weld length in which items (1) and (2) apply shall not exceed a total of 10 percent of the overall weld length. The limited access of the MPC basket panel longitudinal fillet welds makes it difficult to perform effective repairs of these welds and creates the potential for causing additional damage to the basket assembly (e.g., to the neutron absorber and its sheathing) if repairs are attempted. The acceptance criteria provided in the foregoing have been established to comport with the objectives of the basket design and preserve the margins demonstrated in the supporting stress analysis.</p> <p>From the structural standpoint, the weld acceptance criteria are established to ensure that any departure from the ideal, continuous fillet weld seam would not alter the primary bending stresses on which the design of the fuel baskets is predicated. Stated differently, the permitted weld discontinuities are limited in size to ensure that they remain classifiable as local stress elevators ("peak stress", <math>F</math>, in the ASME Code for which specific stress intensity limits do not apply).</p>

Table 2.2.15 (continued)

## LIST OF ASME CODE EXCEPTIONS FOR HI-STORM 100 SYSTEM

Component	Reference ASME Code Section/Article	Code Requirement	Exception, Justification & Compensatory Measures
MPC Basket Assembly	NG-8000	States requirements for nameplates, stamping and reports per NCA-8000.	The HI-STORM 100 System is to be marked and identified in accordance with 10CFR71 and 10CFR72 requirements. No Code stamping is required. The MPC basket data package is to be in conformance with Holtec's QA program.
Overpack Steel Structure	NF-2000	Requires materials to be supplied by ASME approved Material Supplier.	Materials will be supplied by Holtec approved supplier with CMTRs in accordance with NF-2000 requirements.
HI-TRAC Steel Structure	NF-2000	Requires materials to be supplied by ASME approved Material Supplier.	Materials will be supplied by Holtec approved supplier with CMTRs in accordance with NF-2000 requirements.
Overpack Baseplate and Lid Top Plate	NF-4441	Requires special examinations or requirements for welds where a primary member thickness of 1" or greater is loaded to transmit loads in the through thickness direction.	The margins of safety in these welds under loads experienced during lifting operations or accident conditions are quite large. The overpack baseplate welds to the inner shell, pedestal shell, and radial plates are only loaded during lifting conditions and have large safety factors during lifting. Likewise, the top lid plate to lid shell weld has a large structural margin under the inertia loads imposed during a non-mechanistic tipover event.

Table 2.2.15 (continued)

## LIST OF ASME CODE EXCEPTIONS FOR HI-STORM 100 SYSTEM

Component	Reference ASME Code Section/Article	Code Requirement	Exception, Justification & Compensatory Measures
Overpack Steel Structure	NF-3256 NF-3266	Provides requirements for welded joints.	<p>Welds for which no structural credit is taken are identified as "Non-NF" welds in the design drawings by an "***". These non-structural welds are specified in accordance with the pre-qualified welds of AWS D1.1. These welds shall be made by welders and weld procedures qualified in accordance with AWS D1.1 or ASME Section IX.</p> <p>Welds for which structural credit is taken in the safety analyses shall meet the stress limits for NF-3256.2, but are not required to meet the joint configuration requirements specified in these Code articles. The geometry of the joint designs in the cask structures are based on the fabricability and accessibility of the joint, not generally contemplated by this Code section governing supports.</p>
HI-STORM Overpack and HI-TRAC Transfer Cask	NF-3320 NF-4720	NF-3324.6 and NF-4720 provide requirements for bolting	<p>These Code requirements are applicable to linear structures wherein bolted joints carry axial, shear, as well as rotational (torsional) loads. The overpack and transfer cask bolted connections in the structural load path are qualified by design based on the design loadings defined in the FSAR. Bolted joints in these components see no shear or torsional loads under normal storage conditions. Larger clearances between bolts and holes may be necessary to ensure shear interfaces located elsewhere in the structure engage prior to the bolts experiencing shear loadings (which occur only during side impact scenarios).</p> <p>Bolted joints that are subject to shear loads in accident conditions are qualified by appropriate stress analysis. Larger bolt-to-hole clearances help ensure more efficient operations in making these bolted connections, thereby minimizing time spent by operations personnel in a radiation area. Additionally, larger bolt-to-hole clearances allow interchangeability of the lids from one particular fabricated cask to another.</p>

Table 2.2.16

COMPARISON BETWEEN HI-STORM MPC LOADINGS WITH HI-STAR MPC LOADINGS<sup>†</sup>

Loading Condition	Difference Between MPC Loadings Under HI-STAR and HI-STORM Conditions
Dead Load	Unchanged
Design Internal Pressure (normal, off-normal, & accident)	Unchanged
Design External Pressure (normal, off-normal, & accident)	HI-STORM normal and off-normal external pressure is ambient which is less than the HI-STAR 40 psig. The accident external pressure is unchanged.
Thermal Gradient (normal, off-normal, & accident)	Determined by analysis in Chapters 3 and 4
Handling Load (normal)	Unchanged
Earthquake (accident)	Inertial loading increased less than 0.1g's (for free-standing overpack designs).
Handling Load (accident)	HI-STORM vertical and horizontal deceleration loadings are less than those in HI-STAR, but the HI-STORM cavity inner diameter is different and therefore the horizontal loading on the MPC is analyzed in Chapter 3.

<sup>†</sup> HI-STAR MPC loadings are those specified in the HI-STAR SAR under docket number 71-9261, which does not impose any off-normal condition loadings.

## 2.3 SAFETY PROTECTION SYSTEMS

### 2.3.1 General

The HI-STORM 100 System is engineered to provide for the safe long-term storage of spent nuclear fuel (SNF). The HI-STORM 100 will withstand all normal, off-normal, and postulated accident conditions without any uncontrolled release of radioactive material or excessive radiation exposure to workers or members of the public. Special considerations in the design have been made to ensure long-term integrity and confinement of the stored SNF throughout all cask operating conditions. The design considerations, which have been incorporated into the HI-STORM 100 System to ensure safe long-term fuel storage are:

1. The MPC confinement barrier is an enclosure vessel designed in accordance with the ASME Code, Subsection NB with confinement welds inspected by radiography (RT) or ultrasonic testing (UT). Where RT or UT is not possible, a redundant closure system is provided with field welds, which are pressure tested and/or inspected by the liquid penetrant method (see Section 9.1).
2. The MPC confinement barrier is surrounded by the HI-STORM overpack which provides for the physical protection of the MPC.
3. The HI-STORM 100 System is designed to meet the requirements of storage while maintaining the safety of the SNF.
4. The SNF once initially loaded in the MPC does not require opening of the canister for repackaging to transport the SNF.
5. The decay heat emitted by the SNF is rejected from the HI-STORM 100 System through passive means. No active cooling systems are employed.

It is recognized that a rugged design with large safety margins is essential, but that is not sufficient to ensure acceptable performance over the service life of any system. A carefully planned oversight and surveillance plan, which does not diminish system integrity but provides reliable information on the effect of passage of time on the performance of the system is essential. Such a surveillance and performance assay program will be developed to be compatible with the specific conditions of the licensee's facility where the HI-STORM 100 System is installed. The general requirements for the acceptance testing and maintenance programs are provided in Chapter 9. Surveillance requirements are specified in the Technical Specifications in Appendix A to the CoC. .

The structures, systems, and components of the HI-STORM 100 System designated as important to safety are identified in Table 2.2.6. Similar categorization of structures, systems, and components, which are part of the ISFSI, but not part of the HI-STORM 100 System, will

be the responsibility of the 10CFR72 licensee. For HI-STORM 100A, the ISFSI pad is designated ITS, Category C as discussed in Subsection 2.0.4.1.

## 2.3.2 Protection by Multiple Confinement Barriers and Systems

### 2.3.2.1 Confinement Barriers and Systems

The radioactivity which the HI-STORM 100 System must confine originates from the spent fuel assemblies and, to a lesser extent, the contaminated water in the fuel pool. This radioactivity is confined by multiple confinement barriers.

Radioactivity from the fuel pool water is minimized by preventing contact, removing the contaminated water, and decontamination.

An inflatable seal in the annular gap between the MPC and HI-TRAC, and the elastomer seal in the HI-TRAC pool lid prevent the fuel pool water from contacting the exterior of the MPC and interior of the HI-TRAC while submerged for fuel loading. The fuel pool water is drained from the interior of the MPC and the MPC internals are dried. The exterior of the HI-TRAC has a painted surface which is decontaminated to acceptable levels. Any residual radioactivity deposited by the fuel pool water is confined by the MPC confinement boundary along with the spent nuclear fuel.

The HI-STORM 100 System is designed with several confinement barriers for the radioactive fuel contents. Intact fuel assemblies have cladding which provides the first boundary preventing release of the fission products. Fuel assemblies classified as damaged fuel or fuel debris are placed in a damaged fuel container which restricts the release of fuel debris. The MPC is a seal welded enclosure which provides the confinement boundary. The MPC confinement boundary is defined by the MPC baseplate, shell, lid, closure ring, and port cover plates.

The MPC confinement boundary has been designed to withstand any postulated off-normal operations, internal change, or external natural phenomena. The MPC is designed to endure normal, off-normal, and accident conditions of storage with the maximum decay heat loads without loss of confinement. Designed in accordance with the ASME Code, Section III, Subsection NB, with certain NRC-approved alternatives, the MPC confinement boundary provides assurance that there will be no release of radioactive materials from the cask under all postulated loading conditions. Redundant closure of the MPC is provided by the MPC closure ring welds which provide a second barrier to the release of radioactive material from the MPC internal cavity. Therefore, no monitoring system for the confinement boundary is required.

Confinement is discussed further in Chapter 7. MPC field weld examinations, helium leakage testing and pressure testing are performed to verify the confinement function. Fabrication inspections and tests are also performed, as discussed in Chapter 9, to verify the confinement boundary.

### 2.3.2.2 Cask Cooling

To facilitate the passive heat removal capability of the HI-STORM 100, several thermal design criteria are established for normal and off-normal conditions. They are as follows:

- The heat rejection capacity of the HI-STORM 100 System is deliberately understated by conservatively determining the design basis fuel that maximizes thermal resistance (see Section 2.1.6). Additional margin is built into the calculated cask cooling rate by using the design basis fuel assembly that offers maximum resistance to MPC internal helium circulation.
- The MPC fuel basket is formed by a honeycomb structure of stainless steel plates with full-length edge-welded intersections, which allows the unimpaired conduction of heat.
- The MPC confinement boundary ensures that the helium atmosphere inside the MPC is maintained during normal, off-normal, and accident conditions of storage and transfer. The MPC confinement boundary maintains the helium confinement atmosphere below the design temperatures and pressures stated in Table 2.2.3 and Table 2.2.1, respectively.
- The MPC thermal design maintains the fuel rod cladding temperatures below the values stated in Chapter 4 such that fuel cladding is not degraded during the long term storage period.
- The HI-STORM is optimally designed with cooling vents and an MPC to overpack annulus which maximize air flow, while providing superior radiation shielding. The vents and annulus allow cooling air to circulate past the MPC removing the decay heat.

### 2.3.3 Protection by Equipment and Instrumentation Selection

#### 2.3.3.1 Equipment

Design criteria for the HI-STORM 100 System are described in Section 2.2. The HI-STORM 100 System may include use of ancillary or support equipment for ISFSI implementation. Ancillary equipment and structures utilized outside of the reactor facility's 10CFR Part 50 structures may be broken down into two broad categories, namely Important to Safety (ITS) ancillary equipment and Not Important to Safety (NITS) ancillary equipment. NUREG/CR-6407, "Classification of Transportation Packaging and Dry Spent Fuel Storage System Components According to Importance to Safety", provides guidance for the determination of a component's safety classification. Certain ancillary equipment (such as trailers, rail cars, skids, portable cranes, transporters, or air pads) are not required to be designated as ITS for most

ISFSI implementations, if the HI-STORM 100 is designed to withstand the failure of these components.

The listing and ITS designation of ancillary equipment in Table 8.1.6 follows NUREG/CR-6407. ITS ancillary equipment utilized in activities that occur outside the 10CFR Part 50 structure shall be engineered to meet all functional, strength, service life, and operational safety requirements to ensure that the design and operation of the ancillary equipment is consistent with the intent of this Safety Analysis Report. The design for these components shall consider the following information, as applicable:

1. Functions and boundaries of the ancillary equipment
2. The environmental conditions of the ISFSI site, including tornado-borne missile, tornado wind, seismic, fire, lightning, explosion, ambient humidity limits, flood, tsunami and any other environmental hazards unique to the site.
3. Material requirements including impact testing requirements
4. Applicable codes and standards
5. Acceptance testing requirements
6. Quality assurance requirements
7. Foundation type and permissible loading
8. Applicable loads and load combinations
9. Pre-service examination requirements
10. In-use inspection and maintenance requirements
11. Number and magnitude of repetitive loading significant to fatigue
12. Insulation and enclosure requirements (on electrical motors and machinery)
13. Applicable Reg. Guides and NUREGs.
14. Welding requirements
15. Painting, marking, and identification requirements
16. Design Report documentation requirements
17. Operational and Maintenance (O&M) Manual information requirements

All design documentation shall be subject to a review, evaluation, and safety assessment process in accordance with the provisions of the QA program described in Chapter 13.

Users may effectuate the inter-cask transfer of the MPC between the HI-TRAC transfer cask and either the HI-STORM 100 or the HI-STAR 100 overpack in a location of their choice, depending upon site-specific needs and capabilities. For those users choosing to perform the MPC inter-cask transfer using devices not integral to structures governed by the regulations of 10 CFR Part 50 (e.g., fuel handling or reactor building), a Cask Transfer Facility (CTF) is required. The CTF is a stand-alone facility located on-site, near the ISFSI that incorporates or is compatible with lifting devices designed to lift a loaded or unloaded HI-TRAC transfer cask, place it atop the overpack, and transfer the loaded MPC to or from the overpack. The detailed design criteria which must be followed for the design and operation of the CTF are set down in Paragraphs A through R below.



The inter-cask transfer operations consist of the following potential scenarios of MPC transfer:

- Transfer between a HI-TRAC transfer cask and a HI-STORM overpack
- Transfer between a HI-TRAC transfer cask and a HI-STAR 100 overpack

In both scenarios, the standard design HI-TRAC is mounted on top of the overpack (HI-STAR 100, HI-STORM 100, HI-STORM 100S) and the MPC transfer is carried out by opening the transfer lid doors located at the bottom of the HI-TRAC transfer cask and by moving the MPC vertically to the cylindrical cavity of the recipient cask. For the HI-TRAC 100D and 125D designs, the MPC transfer is carried out in a similar fashion, except that there is no transfer lid involved - the pool lid is removed while the transfer cask is mounted atop the HI-STORM overpack with the HI-STORM mating device located between the two casks (see Figure 1.2.18). However, the devices utilized to lift the HI-TRAC cask to place it on the overpack and to vertically transfer the MPC may be of stationary or mobile type.

The specific requirements for the CTF employing stationary and mobile lifting devices are somewhat different. The requirements provided in the following specification for the CTF apply to both types of lifting devices, unless explicitly differentiated in the text.

1. General Specifications:

- i. The cask handling functions which may be required of the Cask Transfer Facility include:
  - a. Upending and downending of a HI-STAR 100 overpack on a flatbed rail car or other transporter (see Figure 2.3.1 for an example).
  - b. Upending and downending of a HI-TRAC transfer cask on a heavy-haul transfer trailer or other transporter (see Figure 2.3.2 for an example)
  - c. Raising and placement of a HI-TRAC transfer cask on top of a HI-STORM 100 overpack for MPC transfer operations (see Figure 2.3.3 for an example of the cask arrangement with the standard design HI-TRAC transfer cask. The HI-TRAC 100D and 125D designs would include the mating device and no transfer lid).
  - d. Raising and placement of a HI-TRAC transfer cask on top of a HI-STAR 100 overpack for MPC transfer operations (see Figure 2.3.4 for an example of the cask arrangement with the standard

design HI-TRAC transfer cask. The HI-TRAC 100D and 125D designs would include the mating device and no transfer lid).

- e. MPC transfer between the HI-TRAC transfer cask and the HI-STORM overpack.
- f. MPC transfer between the HI-TRAC transfer cask and the HI-STAR 100 overpack.

ii. Other Functional Requirements:

The CTF should possess facilities and capabilities to support cask operations such as :

- a. Devices and areas to support installation and removal of the HI-STORM overpack lid.
- b. Devices and areas to support installation and removal of the HI-STORM 100 overpack vent shield block inserts.
- c. Devices and areas to support installation and removal of the HI-STAR 100 closure plate.
- d. Devices and areas to support installation and removal of the HI-STAR 100 transfer collar.
- e. Features to support positioning and alignment of the HI-STORM overpack and the HI-TRAC transfer cask.
- f. Features to support positioning and alignment of the HI-STAR 100 overpack and the HI-TRAC transfer cask.
- g. Areas to support jacking of a loaded HI-STORM overpack for insertion of a translocation device underneath.
- h. Devices and areas to support placement of an empty MPC in the HI-TRAC transfer cask or HI-STAR 100 overpack
- i. Devices and areas to support receipt inspection of the MPC, HI-TRAC transfer cask, HI-STORM overpack, and HI-STAR overpack.

- j. Devices and areas to support installation and removal of the HI-STORM mating device (HI-TRAC 100D and 125D only).
- iii. Definitions:

The components of the CTF covered by this specification consist of all structural members, lifting devices, and foundations which bear all or a significant portion of the dead load of the transfer cask or the multi-purpose canister during MPC transfer operations. The definitions of key terms not defined elsewhere in this FSAR and used in this specification are provided below. The following terms are used to define key components of the CTF.

- Connector Brackets: The mechanical part used in the load path which connects to the cask trunnions. A fabricated weldment, slings, and turnbuckles are typical examples of connector brackets.
- CTF structure: The CTF structure is the stationary, anchored portion of the CTF which provides the required structural function to support MPC transfer operations, including lateral stabilization of the HI-TRAC transfer cask and, if required, the overpack, to protect against seismic events. The MPC lifter, if used in the CTF design, is integrated into the CTF structure (see Lifter Mount).
- HI-TRAC lifter(s): The HI-TRAC lifter is the mechanical lifting device, typically consisting of jacks or hoists, that is utilized to lift a loaded or unloaded HI-TRAC to the required elevation in the CTF so that it can be mounted on the overpack.<sup>†</sup>
- Lifter Mount: A beam-like structure (part of the CTF structure) that supports the HI-TRAC and MPC lifter(s).
- Lift Platform: The lift platform is the intermediate structure that transfers the vertical load of the HI-TRAC transfer cask to the HI-TRAC lifters.

---

<sup>†</sup> The term overpack is used in this specification as a generic term for the HI-STAR 100 and the various HI-STORM overpacks.

- Mobile crane: A mobile crane is a device defined in ASME B30.5-1994, Mobile and Locomotive Cranes. A mobile crane may be used in lieu of the HI-TRAC lifter and/or an MPC lifter provided all requirements set forth in this subsection are satisfied.
- MPC lifter: The MPC lifter is a mechanical lifting device, typically consisting of jacks or hoists, that is utilized to vertically transfer the MPC between the HI-TRAC transfer cask and the overpack.
- Pier: The portion of the reinforced concrete foundation which projects above the concrete floor of the CTF.
- Single-Failure-Proof (SFP): A single-failure-proof handling device is one wherein all directly loaded tension and compression members are engineered to satisfy the enhanced safety criteria given in of NUREG-0612.
- Translocation Device: A low vertical profile device used to laterally position an overpack such that the bottom surface of the overpack is fully supported by the top surface of the device. Typical translocation devices are air pads and Hillman rollers.

iv. Important to Safety Designation:

All components and structures which comprise the CTF shall be given an ITS category designation in accordance with a written procedure which is consistent with NUREG/CR-6407 and the Holtec quality assurance program.

B. Environmental and Design Conditions

- i. Lowest Service Temperature (LST): The LST for the CTF is 0°F (consistent with the specification for the HI-TRAC transfer cask in Subsection 3.1.2.3).
- ii. Snow and Ice Load, S: The CTF structure shall be designed to withstand the dead weight of snow and ice for unheated structures as set forth in ASCE 7-88 [2.2.2] for the specific ISFSI site.

- iii. Tornado Missile, M, and Tornado Wind, W': The tornado wind and tornado-generated missile data applicable to the HI-STORM 100 System (Tables 2.2.4 and 2.2.5) will be used in the design of the CTF structure unless existing site design basis data or a probabilistic risk assessment (PRA) for the CTF site with due consideration of short operation durations indicates that a less severe tornado missile impact or wind loading on the CTF structure can be postulated. The PRA analysis can be performed in the manner of the EPRI Report NP-2005, "Tornado Missile Simulation and Design Methodology Computer Code Manual". USNRC Reg. Guide 1.117 and Section 2.2.3 of NUREG-800 may be used for guidance in establishing the appropriate tornado missile and wind loading for the CTF structure.

The following additional clarifications apply to the large tornado missile (4,000 lb. automobile) in Tables 2.2.4 and 2.2.5 in the CTF structure analysis:

- The missile has a platform area of 20 sq. ft. and impact force characteristics consistent with the HI-TRAC missile impact analysis.
- The large missile can strike the CTF structure in any orientation up to an elevation of 15 feet.

If the site tornado missile data developed by the ISFSI owner suggests that tornado missiles of greater kinetic energies than that postulated in this FSAR (Table 2.2.4 and 2.2.5) should be postulated for CTF during its use, then the integrity analysis of the CTF structure shall be carried out under the site-specific tornado missiles. This situation would also require the HI-TRAC transfer cask and the overpack to be re-evaluated under the provisions of 10CFR72.212 and 72.48.

The wind speed specified in this FSAR (Tables 2.2.4 and 2.2.5), likewise, shall be evaluated for their applicability to the site. Lower or higher site-specific wind velocity, compared to the design basis values cited in this FSAR shall be used if justified by appropriate analysis, which may include PRA.

Intermediate penetrant missile and small missiles postulated in this FSAR are not considered to be a credible threat to the functional integrity of the CTF structure and, therefore, need not be considered.

- iv. Flood: The CTF will be assumed to be flooded to the highest elevation for the CTF facility determined from the local meteorological data. The flood velocity shall be taken as the largest value defined for the ISFSI site.
- v. Lightning: Meteorological data for the region surrounding the ISFSI site shall be used to specify the applicable lightning input to the CTF structure for personnel safety evaluation purposes.
- vi. Water Waves (Tsunami, Y): Certain coastal CTF sites may be subject to sudden, short duration waves of water, denoted in the literature by various terms, such as tsunami. If the applicable meteorological data for the CTF site indicates the potential of such water-borne loadings on the CTF structure, then such a loading, with due consideration of the short duration of CTF operations, shall be defined for the CTF structure.
- vii. Design Basis Earthquake (DBE), E: The DBE event applicable to the CTF facility pursuant to 10CFR100, Appendix A, shall be specified. The DBE should be specified as a set of response spectra or acceleration time-histories for use in the CTF structural and impact consequence analyses.
- viii. Design Temperature: All material properties used in the stress analysis of the CTF structure shall utilize a reference design temperature of 150°F.

C. Heavy Load Handling:

- i. Apparent dead load, D\*: The dead load of all components being lifted shall be increased in the manner set forth in Subsection 3.4.3 to define the Apparent Dead Load, D\*.
- ii. NUREG-0612 Conformance:

The Connector Bracket, HI-TRAC lifter, and MPC lifter shall comply with the guidance provided in NUREG-0612 (1980) for single failure proof devices. Where the geometry of the lifting device is different from the configurations contemplated by NUREG-0612, the following exceptions apply:

- a. Mobile cranes at the CTF shall conform to the guidelines of Section 5.1.1 of NUREG-0612 with the exception that mobile

cranes shall meet the requirements of ANSI B30.5, "Mobile and Locomotive Cranes", in lieu of the requirements of ANSI B30.2, "Overhead and Gantry Cranes". The mobile crane used shall have a minimum safety factor of two over the allowable load table for the crane in accordance with Section 5.1.6(1)(a) of NUREG-0612, and shall be capable of stopping and holding the load during a DBE event.

- b. Section 5.1.6(2) of NUREG-0612 specifies that new cranes should be designed to meet the requirements of NUREG-0554. For mobile cranes, the guidance of Section 5.1.6(2) of NUREG-0612 does not apply.
- iii. Defense-in-Depth Measures:
  - a. The lift platform and the lifter mount shall be designed to ensure that the stresses produced under the apparent dead load,  $D^*$ , are less than the Level A (normal condition) stress limits for ASME Section III, Subsection NF, Class 3, linear structures.
  - b. The CTF structure shall be designed to ensure that the stresses produced in it under the apparent dead load,  $D^*$ , are less than the Level A (normal condition) stress limits for ASME Section III, Subsection NF, Class 3, linear structures.
  - c. Maximum deflection of the lift platform and the lifter mount under the apparent dead load shall comply with the limits set forth in CMAA-70.
  - d. When the HI-TRAC transfer cask is stacked on the overpack, HI-TRAC shall be either held by the lifting device or laterally restrained by the CTF structure. Furthermore, when the HI-TRAC transfer cask is placed atop the overpack, the overpack shall be laterally restrained from uncontrolled movement, if required by the analysis specified in Subsection 2.3.3.1.N.
  - e. The design of the lifting system shall ensure that the lift platform (or lift frame) is held horizontal at all times and that the symmetrically situated axial members are symmetrically loaded.
  - f. In order to minimize occupational radiation exposure to ISFSI personnel, design of the MPC lifting attachment (viz., sling)

should not require any human activity inside the HI-TRAC cylindrical space.

- g. The HI-TRAC lifter and MPC lifter shall possess design features to avoid side-sway of the payload during lifting operations.
- h. The lifter (HI-TRAC and MPC) design shall ensure that any electrical malfunction in the motor or the power supply will not lead to an uncontrolled lowering of the load.
- i. The kinematic stability of HI-TRAC or HI-STORM standing upright in an unrestrained configuration (if such a condition exists during the use of the CTF) shall be analytically evaluated and ensured under all postulated extreme environmental phenomena loadings for the CTF facility.

iv. Shielding Surety:

The design of the HI-TRAC and MPC lifters shall preclude the potential for the MPC to be removed, completely or partially, from the cylindrical space formed by the HI-TRAC and the underlying overpack.

v. Specific Requirements for Mobile Cranes:

A mobile crane, if used in the CTF in the role of the HI-TRAC lifter or MPC lifter is governed in part by ANSI/ASME N45.2.15 with technical requirements specified in ANSI B30.5 (1994).

When lifting the MPC from an overpack to the HI-TRAC transfer cask, limit switches or load limiters shall be set to ensure that the mobile crane is prevented from lifting loads in excess of 110% of the loaded MPC weight.

An analysis of the consequences of a potential MPC vertical drop which conforms to the guidelines of Appendix A to NUREG-0612 shall be performed. The analysis shall demonstrate that a postulated drop would not result in the MPC experiencing a deceleration in excess of its design basis deceleration specified in this FSAR.

vi. Lift Height Limitation: The HI-TRAC lift heights shall be governed by the Technical Specifications.



- vii. Control of Side Sway: Procedures shall provide provisions to ensure that the load is lifted essentially vertically with positive control of the load. Key cask lifting and transfer procedures, as determined by the user, should be reviewed by the Certificate Holder before their use.

D. Loads and Load Combinations for the CTF Structure

The applicable loadings for the CTF have been summarized in paragraph B in the preceding. A stress analysis of the CTF structure shall be performed to demonstrate compliance with the Subsection NF stress limits for Class 3 linear structures for the service condition germane to each load combination. Table 2.3.2 provides the load combinations (the symbols in Table 2.3.2 are defined in the preceding text and in Table 2.2.13).

E. Materials and Failure Modes

- i. Acceptable Materials and Material Properties: All materials used in the design of the CTF shall be ASTM approved or equal, consistent with the ITS category of the part. Reinforced concrete, if used, shall comply with the provisions of ACI 318 (89). The material property and allowable stress values for all steel structures shall be taken from the ASME and B&PV Code, Section II, wherever such data is available; otherwise, the data provided in the ASTM standards shall be used.
- ii. Brittle Fracture: All structural components in the CTF structure and the lift platform designated as primary load bearing shall have an NDTT equal to 0°F or lower (consistent with the ductile fracture requirements for ASME Section III, Subsection NF, Class 3 structures).
- iii. Fatigue: Fatigue failure modes of primary structural members in the CTF structure whose failure may result in uncontrolled lowering of the HI-TRAC transfer cask or the MPC (critical members) shall be evaluated. A minimum factor of safety of 2 on the number of permissible loading cycles on the critical members shall apply.
- iv. Buckling: For all critical members in the CTF structure (defined above), potential failure modes through buckling under axial compression shall be considered. The margin of safety against buckling shall comply with the provisions of ASME Section III, Subsection NF, for Class 3 linear structures.

F. CTF Pad

A reinforced concrete pad in conformance with the specification for the ISFSI pad set forth in this FSAR (see Table 2.2.9) may be used in the region of the CTF where the overpack and HI-TRAC are stacked for MPC transfer. Alternatively, the pad may be designed using the guidelines of ACI-318(89).

G. Miscellaneous Components

Hoist rings, turnbuckles, slings, and other appurtenances which are in the load path during heavy load handling at the CTF shall be single-failure-proof.

H. Structural Welds

All primary structural welds in the CTF structure shall comply with the specifications of ASME Section III for Class 3 NF linear structures.

I. Foundation

The design of the CTF structure foundation and piers, including load combinations, shall be in accordance with ACI-318(89).

J. Rail Access

The rail lines that enter the Cask Transfer Facility shall be set at grade level with no exposed rail ties or hardware other than the rail itself.

K. Vertical Cask Crawler/Translocation Device Access (If Required)

- i. The cask handling bay in the CTF shall allow access of a vertical cask crawler or translocation device carrying a transfer cask or overpack. The building floor shall be equipped with a smooth transition to the cask travel route such that the vertical cask crawler tracks do not have to negotiate sharp lips or slope transitions and the translocation devices have a smooth transition. Grading of exterior aprons shall be no more than necessary to allow water drainage.
- ii. If roll-up doors are used, the roll up doors shall have no raised threshold that could damage the vertical cask crawler tracks (if a crawler is used).
- iii. Exterior aprons shall be of a material that will not be damaged by the vertical cask crawler tracks, if a crawler is used.

L. Facility Floor

- i. The facility floor shall be sufficiently flat to allow optimum handling of casks with a translocation device.
- ii. Any floor penetrations, in areas where translocation device operations may occur, shall be equipped with flush inserts.
- iii. The rails, in areas where translocation device operations may occur shall be below the finish level of the floor. Flush inserts, if necessary, shall be sized for installation by hand.

M. Cask Connector Brackets

- i. Primary lifting attachments between the cask and the lifting platform are the cask connector brackets. The cask connector brackets may be lengthened or shortened to allow for differences in the vehicle deck height of the cask delivery vehicle and the various lifting operations. The connector brackets shall be designed to perform cask lifting, upending and downending functions. The brackets shall be designed in accordance with ANSI N14.6 [Reference 2.2.3] and load tested at 300% of the load applied to them during normal handling.
- ii. The connector brackets shall be equipped with a positive engagement to ensure that the cask lifting attachments do not become inadvertently disconnected during a seismic event and during normal cask handling operations.
- iii. The design of the connector brackets shall ensure that the HI-TRAC transfer cask is fully secured against slippage during MPC transfer operations.

N. Cask Restraint System

A time-history analysis of the stacked overpack/HI-TRAC transfer cask assemblage under the postulated ISFSI Level D events in Table 2.3.2 shall be performed to demonstrate that a minimum margin of safety of 1.1 against overturning or kinematic instability exists and that the CTF structure complies with the applicable stress limits (Table 2.3.2) and that the maximum permissible deceleration loading specified in the FSAR is not exceeded. If required to meet

the minimum margin of safety of 1.1, a cask restraining system shall be incorporated into the design of the Cask Transfer Facility to provide lateral restraint to the overpack (HI-STORM or HI-STAR 100).

O. Design Life

The Cask Transfer Facility shall be constructed to have a minimum design life of 40 years.

P. Testing Requirements

In addition to testing recommended in NUREG-0612 (1980), a structural adequacy test of the CTF structure at 125% of its operating load prior to its first use in a cask loading campaign shall be performed. This test should be performed in accordance with the guidance provided in the CMAA Specification 70 [2.2.16].

Q. Quality Assurance Requirements

All components of the CTF shall be manufactured in full compliance with the quality assurance requirements applicable to the ITS category of the component as set forth in the Holtec QA program.

R. Documentation Requirements

- i. O&M Manual: An Operations and Maintenance Manual shall be prepared which contains, at minimum, the following items of information:
  - Maintenance Drawings
  - Operating Procedures
- ii. Design Report: A QA-validated design report documenting full compliance with the provisions of this specification shall be prepared and archived for future reference in accordance with the provisions of the Holtec QA program.

2.3.3.2 Instrumentation

As a consequence of the passive nature of the HI-STORM 100 System, instrumentation which is important to safety is not necessary. No instrumentation is required or provided for HI-STORM 100 storage operations, other than normal security service instruments and TLDs.

---

HOLTEC INTERNATIONAL COPYRIGHTED MATERIAL

However, in lieu of performing the periodic inspection of the HI-STORM overpack vent screens, temperature elements may be installed in two of the overpack exit vents to continuously monitor the air temperature. If the temperature elements and associated temperature monitoring instrumentation are used, they shall be designated important to safety as specified in Table 2.2.6.

The temperature elements and associated temperature monitoring instrumentation provided to monitor the air outlet temperature shall be suitable for a temperature range of -40°F to 500°F. At a minimum, the temperature elements and associated temperature monitoring instrumentation shall be calibrated for the temperatures of 32°F (ice point), 212°F (boiling point), and 449°F (melting point of tin) with an accuracy of +/- 4°F.

#### 2.3.4 Nuclear Criticality Safety

The criticality safety criteria stipulates that the effective neutron multiplication factor,  $k_{eff}$ , including statistical uncertainties and biases, is less than 0.95 for all postulated arrangements of fuel within the cask under all credible conditions.

##### 2.3.4.1 Control Methods for Prevention of Criticality

The control methods and design features used to prevent criticality for all MPC configurations are the following:

- a. Incorporation of permanent neutron absorbing material in the MPC fuel basket walls.
- b. Favorable geometry provided by the MPC fuel basket

Additional control methods used to prevent criticality for the MPC-24, MPC-24E, and MPC-24EF (all with higher enriched fuel), and the MPC-32 and MPC-32F are the following:

- a. Loading of PWR fuel assemblies must be performed in water with a minimum boron content as specified in Table 2.1.14 or 2.1.16, as applicable.
- b. Prevention of fresh water entering the MPC internals.

Administrative controls and shall be used to ensure that fuel placed in the HI-STORM 100 System meets the requirements described in Chapters 2 and 6. All appropriate criticality analyses are presented in Chapter 6.

#### 2.3.4.2 Error Contingency Criteria

Provision for error contingency is built into the criticality analyses performed in Chapter 6. Because biases and uncertainties are explicitly evaluated in the analysis, it is not necessary to introduce additional contingency for error.

#### 2.3.4.3 Verification Analyses

In Chapter 6, critical experiments are selected which reflect the design configurations. These critical experiments are evaluated using the same calculation methods, and a suitable bias is incorporated in the reactivity calculation.

#### 2.3.5 Radiological Protection

##### 2.3.5.1 Access Control

As required by 10CFR72, uncontrolled access to the ISFSI is prevented through physical protection means. A peripheral fence with an appropriate locking and monitoring system is a standard approach to limit access. The details of the access control systems and procedures, including division of the site into radiation protection areas, will be developed by the licensee (user) of the ISFSI utilizing the HI-STORM 100 System.

##### 2.3.5.2 Shielding

The shielding design is governed by 10CFR72.104 and 10CFR72.106 which provide radiation dose limits for any real individual located at or beyond the nearest boundary of the controlled area. The individual must not receive doses in excess of the limits given in Table 2.3.1 for normal, off-normal, and accident conditions.

The objective of shielding is to assure that radiation dose rates at key locations are as low as practical in order to maintain occupational doses to operating personnel As Low As Reasonably Achievable (ALARA) and to meet the requirements of 10 CFR 72.104 and 10 CFR 106 for dose at the controlled area boundary. Three locations are of particular interest in the storage mode:

- immediate vicinity of the cask
- restricted area boundary
- controlled area (site) boundary

Dose rates in the immediate vicinity of the loaded overpack are important in consideration of occupational exposure. Conservative evaluations of dose rate have been performed and are described in Chapter 5 based on the contents of the BWR and PWR MPCs permitted for storage as described in Section 2.1.9. Actual dose rates in operation will be lower than those reported in Chapter 5 for the following reasons:

- The shielding evaluation model has a number of conservatisms, as discussed in Chapter 5.
- No single cask will likely contain design basis fuel in each fuel storage location and the full compliment of non-fuel hardware allowed by Section 2.1.9.
- No single cask will contain fuel and non-fuel hardware at the limiting burnups and cooling times allowed by Section 2.1.9.

Consistent with 10 CFR 72, there is no single dose rate limit established for the HI-STORM 100 System. Compliance with the regulatory limits on occupational and controlled area doses is performance-based, as demonstrated by dose monitoring performed by each cask. A design objective for the maximum average radial surface dose rate has been established as 135 mrem/hr. Areas adjacent to the inlet and exit vents which pass through the radial shield are limited to 135 mrem/hr. The average dose rate at the top of the overpack is limited to below 60 mrem/hr. Chapter 5 of this FSAR presents the analyses and evaluations to establish HI-STORM 100 compliance with these design objectives.

Because of the passive nature of the HI-STORM 100 System, human activity related to the system is infrequent and of short duration. Personnel exposures due to operational and maintenance activities are discussed in Chapter 10. Chapter 10 also provides information concerning temporary shielding which may be utilized to reduce the personnel dose during loading, unloading, transfer, and handling operations. The estimated occupational doses for personnel comply with the requirements of 10CFR20.

For the loading and unloading of the HI-STORM overpack with the MPC, several transfer cask designs are provided (i.e., HI-TRAC 125, HI-TRAC 100, HI-TRAC 100D and HI-TRAC 125D). The two 125 ton HI-TRAC provide better shielding than the HI-TRAC 100D and 125D due to the increased shielding thickness and corresponding greater weight. Provided the licensee is capable of utilizing the 125 ton HI-TRAC, ALARA considerations would normally dictate that the 125 ton HI-TRAC should be used. However, sites may not be capable of utilizing the 125 ton HI-TRAC due to crane capacity limitations, floor loading limitations, or other site-specific considerations. As with other dose reduction-based plant activities, individual users who cannot accommodate the 125 ton HI-TRAC should perform a cost-benefit analysis of the actions (e.g., plant modifications) that would be necessary to use the 125 ton HI-TRAC. The cost of the action(s) would be weighed against the value of the projected reduction in radiation exposure and a decision made based on each plant's particular ALARA implementation philosophy.

Dose rates at the restricted area and site boundaries shall be in accordance with applicable regulations. Licensees shall demonstrate compliance with 10CFR72.104 and 10CFR72.106 for the actual fuel being stored, the ISFSI storage array, and the controlled area boundary distances.

The analyses presented in Chapters 5, 10, and 11 demonstrate that the HI-STORM 100 System is capable of meeting the above radiation dose limits.

#### 2.3.5.3 Radiological Alarm System

There are no credible events that could result in release of radioactive materials or increases in direct radiation above the requirements of 10CFR72.106.

#### 2.3.6 Fire and Explosion Protection

There are no combustible or explosive materials associated with the HI-STORM 100 System. No such materials would be stored within an ISFSI. However, for conservatism we have analyzed a hypothetical fire accident as a bounding condition for HI-STORM 100. An evaluation of the HI-STORM 100 System in a fire accident is discussed in Chapter 11.

Small overpressures may result from accidents involving explosive materials which are stored or transported near the site. Explosion is an accident loading condition considered in Chapter 11.



Table 2.3.1

RADIOLOGICAL SITE BOUNDARY REQUIREMENTS

BOUNDARY OF CONTROLLED AREA (m) (minimum)	100
NORMAL AND OFF-NORMAL CONDITIONS:	
Whole Body (mrem/yr)	25
Thyroid (mrem/yr)	75
Any Other Critical Organ (mrem/yr)	25
DESIGN BASIS ACCIDENT:	
TEDE (rem)	5
DDE + CDE to any individual organ or tissue (other than lens of the eye) (rem)	50
Lens dose equivalent (rem)	15
Shallow dose equivalent to skin or any extremity (rem)	50

Table 2.3.2

Load Combinations<sup>†</sup> and Service Condition Definitions for the CTF Structure

Load Combination	Service Condition for Section III of the ASME Code for Definition of Allowable Stress	Comment
D*	Level A	All primary load bearing members must satisfy Level A stress limits.
D+S	Level A	
D+M <sup>††</sup> +W' D+F D+E or D+Y	Level D	Factor of safety against overturning shall be $\geq 1.1$

<sup>†</sup> The reinforced concrete portion of the CTF structure shall also meet factored combinations of the above loads set forth in ACI-318(89).

<sup>††</sup> This load may be reduced or eliminated based on a PRA for the CTF site.

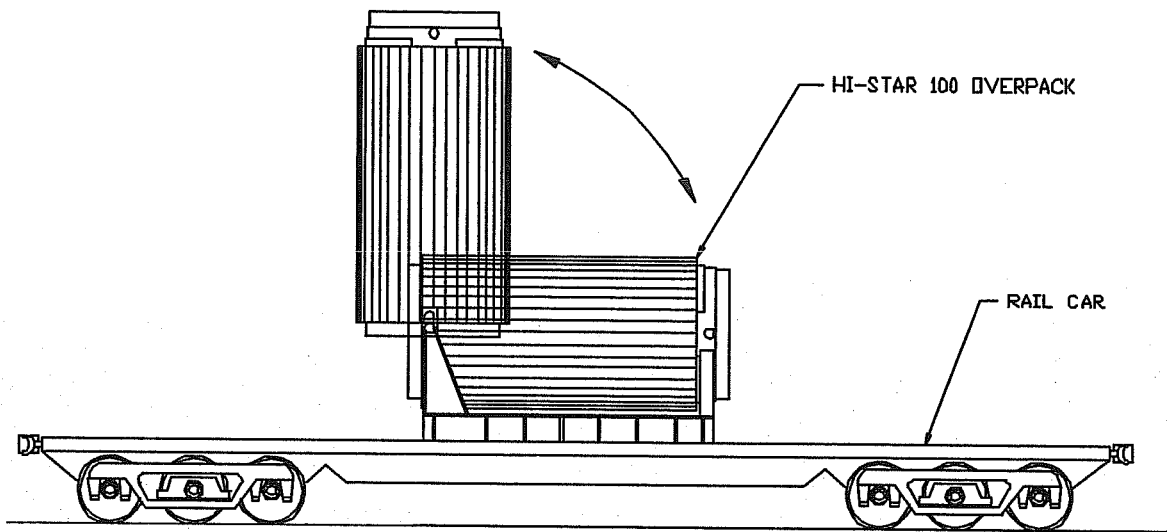

**FIGURE 2.3.1; HI-STAR 100 UPENDING AND DOWNENDING ON A RAIL CAR**

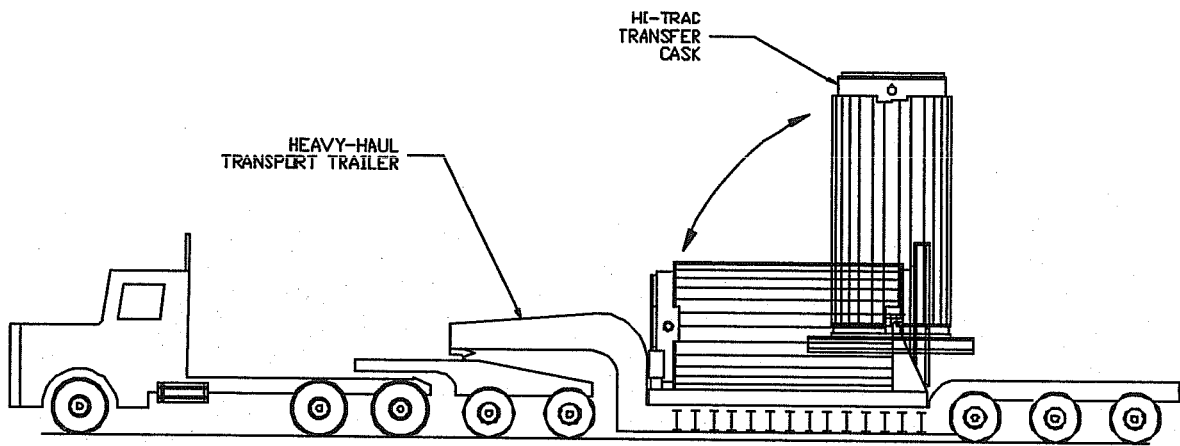

**FIGURE 2.3.2; HI-TRAC UPENDING AND DOWNENDING ON A HEAVY-HAUL TRANSPORT TRAILER**

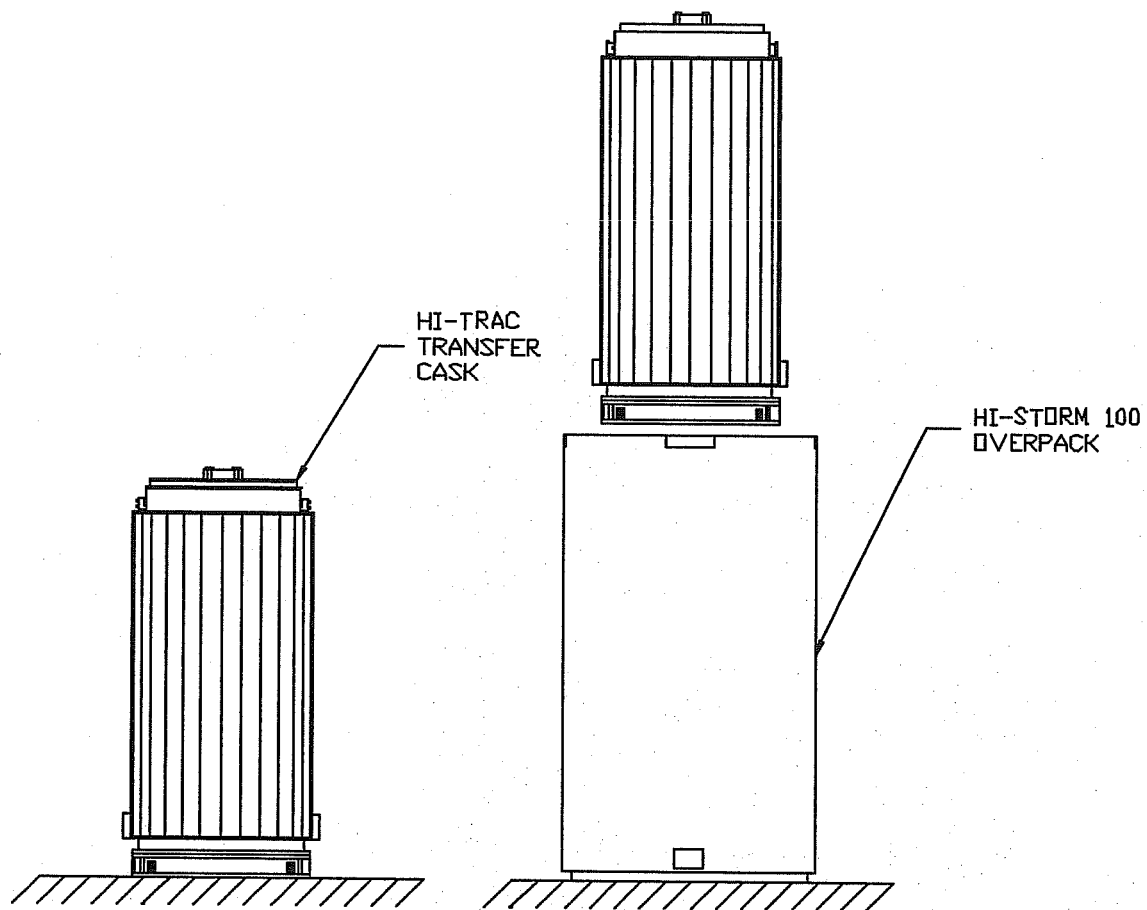

**FIGURE 2.3.3; HI-TRAC PLACEMENT ON HI-STORM 100 FOR MPC TRANSFER OPERATIONS**

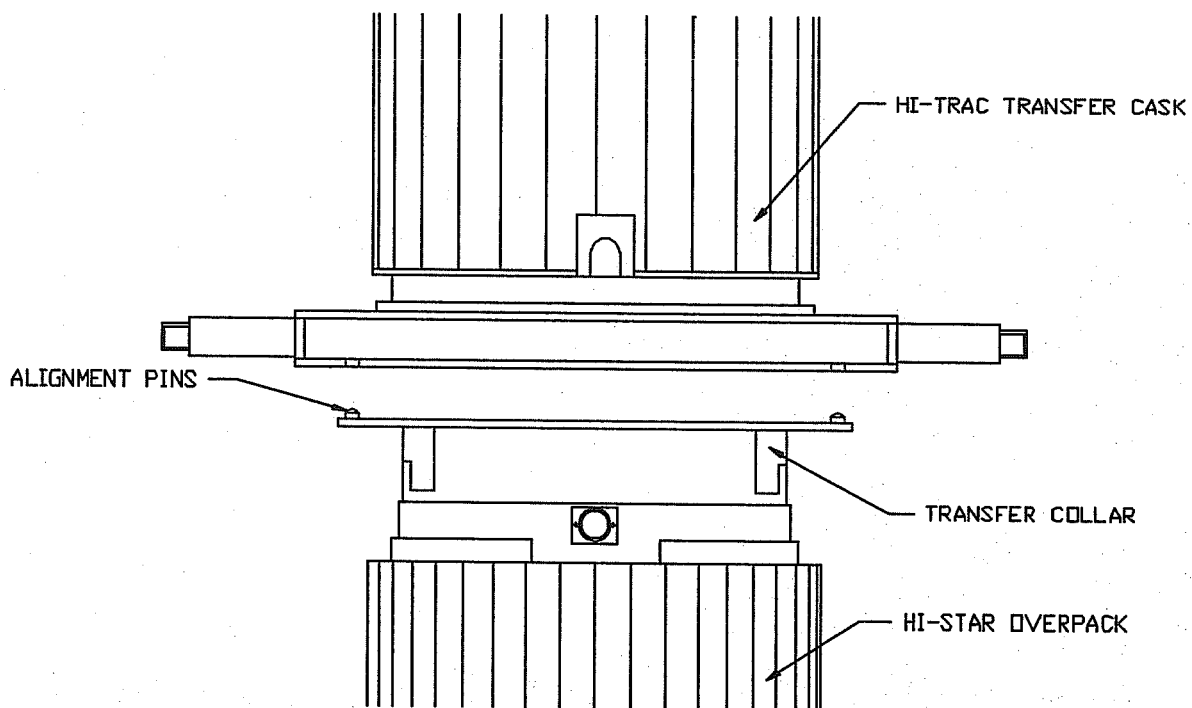

**FIGURE 2.3.4; HI-TRAC PLACEMENT ON HI-STAR 100 FOR MPC TRANSFER OPERATIONS**

## 2.4 DECOMMISSIONING CONSIDERATIONS

Efficient decommissioning of the ISFSI is a paramount objective of the HI-STORM 100 System. The HI-STORM 100 System is ideally configured to facilitate rapid, safe, and economical decommissioning of the storage site.

The MPC is being licensed for transport off-site in the HI-STAR 100 dual-purpose cask system (Reference Docket No. 71-9261). No further handling of the SNF stored in the MPC is required prior to transport to a licensed centralized storage facility or licensed repository.

The MPC, which holds the SNF assemblies is engineered to be suitable as a waste package for permanent internment in a deep Mined Geological Disposal System (MGDS). The materials of construction permitted for the MPC are known to be highly resistant to severe environmental conditions. No carbon steel, paint, or coatings are used or permitted in the MPC. Therefore, the SNF assemblies stored in the MPC should not need to be removed. However, to ensure a practical, feasible method to defuel the MPC, the top of the MPC is equipped with sufficient gamma shielding and markings locating the drain and vent locations to enable semiautomatic (or remotely actuated) boring of the MPC lid to provide access to the MPC vent and drain. The circumferential welds of the MPC lid closure ring can be removed by semiautomatic or remotely actuated means, providing access to the SNF.

Likewise, the overpack consists of steel and concrete rendering it suitable for permanent burial. Alternatively, the MPC can be removed from the overpack, and the latter reused for storage of other MPCs.

In either case, the overpack would be expected to have no interior or exterior radioactive surface contamination. Any neutron activation of the steel and concrete is expected to be extremely small, and the assembly would qualify as Class A waste in a stable form based on definitions and requirements in 10CFR61.55. As such, the material would be suitable for burial in a near-surface disposal site as Low Specific Activity (LSA) material.

If the MPC needs to be opened and separated from the SNF before the fuel is placed into the MGDS, the MPC interior metal surfaces will be decontaminated using existing mechanical or chemical methods. This will be facilitated by the MPC fuel basket and interior structures' smooth metal surfaces designed to minimize crud traps. After the surface contamination is removed, the MPC radioactivity will be diminished significantly, allowing near-surface burial or secondary applications at the licensee's facility.

It is also likely that both the overpack and MPC, or extensive portions of both, can be further decontaminated to allow recycle or reuse options. After decontamination, the only radiological hazard the HI-STORM 100 System may pose is slight activation of the HI-STORM 100 materials caused by irradiation over a 40-year storage period.

Due to the design of the HI-STORM 100 System, no residual contamination is expected to be left behind on the concrete ISFSI pad. The base pad, fence, and peripheral utility structures will require no decontamination or special handling after the last overpack is removed.

To evaluate the effects on the MPC and HI-STORM overpack caused by irradiation over a 40-year storage period, the following analysis is provided. Table 2.4.1 provides the conservatively determined quantities of the major nuclides after 40 years of irradiation. The calculation of the material activation is based on the following:

- Beyond design basis fuel assemblies (B&W 15x15, 4.8% enrichment, 70,000 MWD/MTU, and five-year cooling time) stored for 40 years. A constant source term for 40 years was used with no decrease in the neutron source term. This bounds the source term associated with the limiting PWR burnup of 68,200 MWD/MTU.
- Material quantities based on the drawings in Section 1.5.
- A constant flux equal to the initial loading condition is conservatively assumed for the full 40 years.
- Material activation is based on MCNP-4A calculations.

As can be seen from the material activation results presented in Table 2.4.1, the MPC and HI-STORM overpack activation is very low, even including the very conservative assumption of a constant flux for 40 years. The results for the concrete in the HI-STORM overpack can be conservatively applied to the ISFSI pad. This is extremely conservative because the overpack shields most of the flux from the fuel and, therefore, the ISFSI pad will experience a minimal flux.

In any case, the HI-STORM 100 System would not impose any additional decommissioning requirements on the licensee of the ISFSI facility per 10CFR72.30, since the HI-STORM 100 System could eventually be shipped from the site.



Table 2.4.1  
MPC ACTIVATION

Nuclide	Activity After 40-Year Storage (Ci/m <sup>3</sup> )
<sup>54</sup> Mn	2.20e-3
<sup>55</sup> Fe	3.53e-3
<sup>59</sup> Ni	2.91e-6
<sup>60</sup> Co	3.11e-4
<sup>63</sup> Ni	9.87e-5
Total	6.15e-3

HI-STORM OVERPACK ACTIVATION

Nuclide	Activity After 40-Year Storage (Ci/m <sup>3</sup> )
Overpack Steel	
<sup>54</sup> Mn	3.62e-4
<sup>55</sup> Fe	7.18e-3
Total	7.18e-3
Overpack Concrete	
<sup>39</sup> Ar	3.02e-6
<sup>41</sup> Ca	2.44e-7
<sup>54</sup> Mn	1.59e-7
<sup>55</sup> Fe	2.95e-5
Total	3.43e-5

## 2.5 REGULATORY COMPLIANCE

Chapter 2 provides the principal design criteria related to structures, systems, and components important to safety. These criteria include specifications regarding the fuel, as well as, external conditions that may exist in the operating environment during normal and off-normal operations, accident conditions, and natural phenomena events. The chapter has been written to provide sufficient information to allow verification of compliance with 10CFR72, NUREG-1536, and Regulatory Guide 3.61. A more detailed evaluation of the design criteria and an assessment of compliance with those criteria is provided in Chapters 3 through 13.

## 2.6 REFERENCES

- [2.0.1] American Concrete Institute, "Building Code Requirements for Structural Concrete", ACI 318-95, ACI, Detroit, Michigan.
- [2.0.2] American Concrete Institute, "Code Requirements for Nuclear Safety Related Concrete Structures", ACI 349-85, ACI, Detroit, Michigan<sup>†</sup>
- [2.0.3] Deleted.
- [2.0.4] NRC Regulatory Guide 7.10, "Establishing Quality Assurance Programs for Packaging Used in the Transport of Radioactive Material," USNRC, Washington, D.C. Rev. 1 (1986).
- [2.0.5] J.W. McConnell, A.L. Ayers, and M.J. Tyacke, "Classification of Transportation Packaging and Dry Spent Fuel Storage System Component According to Important to Safety," Idaho Engineering Laboratory, NUREG/CR-6407, INEL-95-0551, 1996.
- [2.0.6] NUREG-1567, Standard Review Plan for Spent Fuel Dry Storage Facilities, March 2000
- [2.0.7] ASME Code, Section III, Subsection NF and Appendix F, and Code Section II, Part D, Materials, 1995, with Addenda through 1997.
- [2.0.8] "Cladding Considerations for the Transportation and Storage of Spent Fuel," USNRC Interim Staff Guidance-11, Revision 3, November 17, 2003.
- [2.0.9] USNRC Memorandum from Christopher L. Brown to M. Wayne Hodges, "Scoping Calculations for Cladding Hoop Stresses in Low Burnup Fuel," dated January 29, 2004.
- [2.1.1] ORNL/TM-10902, "Physical Characteristics of GE BWR Fuel Assemblies", by R.S. Moore and K.J. Notz, Martin Marietta (1989).
- [2.1.2] U.S. DOE SRC/CNEAF/96-01, Spent Nuclear Fuel Discharges from U.S. Reactors 1994, Feb. 1996.
- [2.1.3] Deleted.
- [2.1.4] Deleted.

---

<sup>†</sup> The 1997 edition of ACI-349 is specified for ISFSI pad and embedment design for deployment of the anchored HI-STORM 100A and HI-STORM 100SA.

- [2.1.5] NUREG-1536, SRP for Dry Cask Storage Systems, USNRC, Washington, DC, January 1997.
- [2.1.6] DOE Multi-Purpose Canister Subsystem Design Procurement. Specification.
- [2.1.7] S.E. Turner, "Uncertainty Analysis - Axial Burnup Distribution Effects," presented in "Proceedings of a Workshop on the Use of Burnup Credit in Spent Fuel Transport Casks", SAND-89-0018, Sandia National Laboratory, Oct., 1989.
- [2.1.8] Commonwealth Edison Company, Letter No. NFS-BND-95-083, Chicago, Illinois.
- [2.2.1] ASME Boiler & Pressure Vessel Code, American Society of Mechanical Engineers, 1995 with Addenda through 1997.
- [2.2.2] ASCE 7-88 (formerly ANSI A58.1), "Minimum Design Loads for Buildings and Other Structures", American Society of Civil Engineers, New York, NY, 1990.
- [2.2.3] ANSI N14.6-1993, "Special Lifting Devices for Shipping Containers Weighing 10,000 Pounds (4500 Kg) or More", June 1993.
- [2.2.4] Holtec Report HI-2012610, "Final Safety Analysis Report for the HI-STAR 100 Cask System", NRC Docket No. 72-1008, latest revision , .
- [2.2.5] Holtec Report HI-951251, "Safety Analysis Report for the HI-STAR 100 Cask System", NRC Docket No. 71-9261, latest revision.
- [2.2.6] "Debris Collection System for Boiling Water Reactor Consolidation Equipment", EPRI Project 3100-02 and ESEERCO Project EP91-29, October 1995.
- [2.2.7] Design Basis Tornado for Nuclear Power Plants, Regulatory Guide 1.76, U.S. Nuclear Regulatory Commission, April 1974.
- [2.2.8] ANSI/ANS 57.9-1992, "Design Criteria for an Independent Spent Fuel Storage Installation (dry type)", American Nuclear Society, LaGrange Park, Illinois.
- [2.2.9] NUREG-0800, SRP 3.5.1.4, USNRC, Washington, DC.

- [2.2.10] United States Nuclear Regulatory Commission Regulatory Guide 1.59, "Design Basis Floods for Nuclear Power Plants", August 1973 and Rev. 1, April 1976.
- [2.2.11] "Estimate of Tsunami Effect at Diablo Canyon Nuclear Generating Station, California." B.W. Wilson, PG&E (September 1985, Revision 1).
- [2.2.12] Deleted.
- [2.2.13] Deleted.
- [2.2.14] Deleted.
- [2.2.15] Deleted.
- [2.2.16] Crane Manufacturer's Association of America (CMAA), Specification #70, 1988, Section 3.3.

## APPENDIX 2.A

### GENERAL DESIGN AND CONSTRUCTION REQUIREMENTS FOR THE ISFSI PAD FOR HI-STORM 100A

#### 2.A.1 General Comments

As stated in Section 2.0.4, an ISFSI slab that anchors a spent fuel storage cask should be classified as "important to safety." This classification of the slab follows from the provisions of 10CFR72, which require that the cask system retain its capacity to store spent nuclear fuel in a safe configuration subsequent to a seismic or other environmental event. Since the slab for anchored HI-STORM deployment is designated as ITS, the licensee is required to determine whether the reactor site parameters, including earthquake intensity and large missiles, are enveloped by the cask design bases. The intent of the regulatory criteria is to ensure that the slab meets all interface requirements of the cask design and the geotechnical characteristics of the ISFSI site.

This appendix provides general requirements for design and construction of the ISFSI concrete pad as an ITS structure, and also establishes the framework for ensuring that the ISFSI design bases are clearly articulated. The detailed design of the ISFSI pad for anchored HI-STORM deployment shall comply with the technical provisions set forth in this appendix.

#### 2.A.2 General Requirements for ISFSI Pad

1. Consistent with the provisions of NUREG-1567 [2.0.6], all concrete work shall comply with the requirements of ACI-349-97 [2.0.2].
2. All reinforcing steel shall be manufactured from high strength billet steel conforming to ASTM designation A615 Grade 60.
3. The ISFSI owner shall develop appropriate mixing, pouring, reinforcing steel placement, curing, testing, and documentation procedures to ensure that all provisions of ACI 349-97 [2.0.2] are met.
4. The placement, depth, and design and construction of the slab shall take into account the depth of the frost line at the ISFSI location. The casks transmit a very small amount of heat into the cask pad through conduction. The American Concrete Institute guidelines on reinforced concrete design of ground level slabs to minimize thermal and shrinkage induced cracking shall be followed.

5. General Requirements for Steel Embedment: The steel embedment, excluding the pre-tensioned anchorage studs, is required to follow the provisions stipulated in ACI 349-97 [2.0.2], Appendix B "Steel Embedment" and the associated Commentary on Appendix B, as applicable. Later editions of this Code may be used provided a written reconciliation is performed. An example of one acceptable embedment configuration is provided in Figure 2.A.1. Site-specific embedment designs may vary from this example, depending on the geotechnical characteristics of the site-specific foundation. The embedment designer shall consider any current, relevant test data in designing the pad embedment for HI-STORM 100A and HI-STORM 100SA.
6. The ISFSI owner shall ensure that pad design analyses, using interface loads provided in this report, demonstrate that all structural requirements of NUREG-1567 and ACI-349-97 are satisfied.
7. Unless the load handling device is designed in accordance with ANSI N14.6 and incorporates redundant drop protection features, the ISFSI owner shall ensure that a permissible cask carry height is computed for the site-specific pad/foundation configuration such that the design basis deceleration set forth in this FSAR are not exceeded in the event of a handling accident involving a vertical drop.
8. The ISFSI owner shall ensure that the pad/foundation configuration provides sufficient safety margins for overall kinematic stability of the cask/pad/foundation assemblage.
9. The ISFSI owner shall ensure that the site-specific seismic inputs, established at the top surface of the ISFSI pad, are bounded by the seismic inputs used as the design basis for the attachment components. If required, the ISFSI owner shall perform additional analyses to ensure that the site-specific seismic event or durations greater than the design basis event duration analyzed in this report, do not produce a system response leading to structural safety factors (defined as allowable stress (load) divided by calculated stress (load)) less than 1.0. Table 2.0.5 and Table 2.2.8 provide the limiting values of ZPAs in the three orthogonal directions that must not be exceeded at an ISFSI site (on the pad top surface) to comply with the general CoC for the HI-STORM 100A (and 100SA) System.
10. An ISFSI pad used to support anchored HI-STORM overpacks, unlike the case of free standing overpacks, may experience tensile (vertically upward) anchorage forces in addition to compression loads. The reinforcing steel (pattern and quantity) must be selected to meet the demands of the anchorage forces under seismic and other environmental conditions that involve destabilizing loadings (such as the large tornado missile defined in this FSAR).

### 2.A.3 Steel Embedment for Anchored Casks

Figure 2.A.1 shows a typical fastening arrangement for the HI-STORM 100A System. The details of the rebars in the pad (which are influenced by the geotechnical characteristics of the foundation and its connection to the underlying continuum) are not shown in Figure 2.A.1. Representative dimensions of the embedment and anchorage system are provided in Table 2.A.1.

The embedment detail illustrated in Figure 2.A.1 is designed to resist a load equal to the ASME Code, Section III Appendix F Level D load capacity of the cask anchor studs. The figure does not show the additional reinforcement required to ensure that tensile cracking of concrete is inhibited (see Figure B-4 in the Commentary ACI-349R-97) as this depends on the depth chosen for the ITS ISFSI pad concrete. The ACI Code contemplates ductile failure of the embedment steel and requires that the ultimate load capacity of the steel embedment be less than the limit pullout strength of the concrete surrounding the embedment that resists the load transferred from the cask anchor stud. If this criterion cannot be assured, then additional reinforcement must be added to inhibit concrete cracking (per Subsection B.4.4 of Appendix B of ACI-349-97).

The anchor stud receptacle described in Figure 2.A.1 is configured so that the cask anchor studs (which interface with the overpack baseplate as well as the pad embedment per Table 2.0.5 and are designed in accordance with ASME Section III, Subsection NF stress limits), sits flush with the ISFSI top surface while the cask is being positioned. Thus, a translocation device such as an "air pad" (that requires a flat surface) can be used to position the HI-STORM overpack at the designated location. Subsequent to positioning of the cask, the cask anchor stud is raised, the anchor stud nut installed, and the anchor stud preload applied. The transfer of load from the cask anchor stud to the embedment is through the bearing surface of the lower head of the cask anchor stud and the upper part of the anchor stud receptacle shown in the figure. The members of the anchoring system illustrated in Figure 2.A.1, as well as other geometries developed by the ISFSI designer, must meet the following criteria:

- i. The weakest structural link in the system shall be in the ductile member. In other words, the tension capacity of the anchor stud/anchor receptacle group (based on the material ultimate strengths) shall be less than the concrete pull-out strength (computed with due recognition of the rebars installed in the pad).
- ii. The maximum ratio of embedment plus cask anchor stud effective tensile stiffness to the effective compressive stiffness of the embedment plus concrete shall not exceed 0.25 in order to ensure the effectiveness of the pre-load.
- iii. The maximum axial stress in the cask anchor studs under normal and seismic conditions shall be governed by the provisions of ASME Section III Subsection NF (1995).



- iv. The load-bearing members of the HI-STORM 100A anchorage system shall be considered important-to-safety. This includes the following components shown in Figure 2.A.1: anchor stud and nut, top ring, upper collar, anchor receptacle, and anchor ring.

For sites with lower ZPA DBE events, compared to the limiting ZPAs set down in this FSAR, the size of the anchor studs and their number can be appropriately reduced. However, the above three criteria must be satisfied in all cases.

Table 2.A.1

Typical Embedment and Anchoring Data\*

Nominal diameter of the anchor stud, (inch)	2
Thickness of the embedment ring, (inch)	2
I.D. of the embedment ring, (inch)	130
Anchor receptacle:	
Upper Position O.D. and I.D. (inch)	O.D.: 2.5 / I.D.: 2.125 (min.)
Lower portion O.D. and I.D. (inch)	O.D.: 4.875 / I.D.: 3.625 (min.)
Depth of anchor receptacle collar, d, (inch)	2.5
Free fall height of the anchor stud, $h_e$ , (inch)	8
<b>Representative Materials of Construction are as follows:†</b>	
Anchor Studs:	Per Table 2.0.4
Anchor Receptacle:	Low carbon steel such as A-36, A-105
Top Ring, Upper Collar, Anchor Ring:	Low carbon steel such as A-36, SA-516-Gr. 70

\* Refer to Figure 2.A.1

† The ISFSI designer shall ensure that all permanently affixed embedment parts (such as the anchor receptacle) made from materials vulnerable to deleterious environmental effects (e.g. low carbon steel) are protected through the use of suitably engineered corrosion barrier. Alternatively, the selected material of construction must be innately capable of withstanding the long term environmental conditions at the ISFSI site.

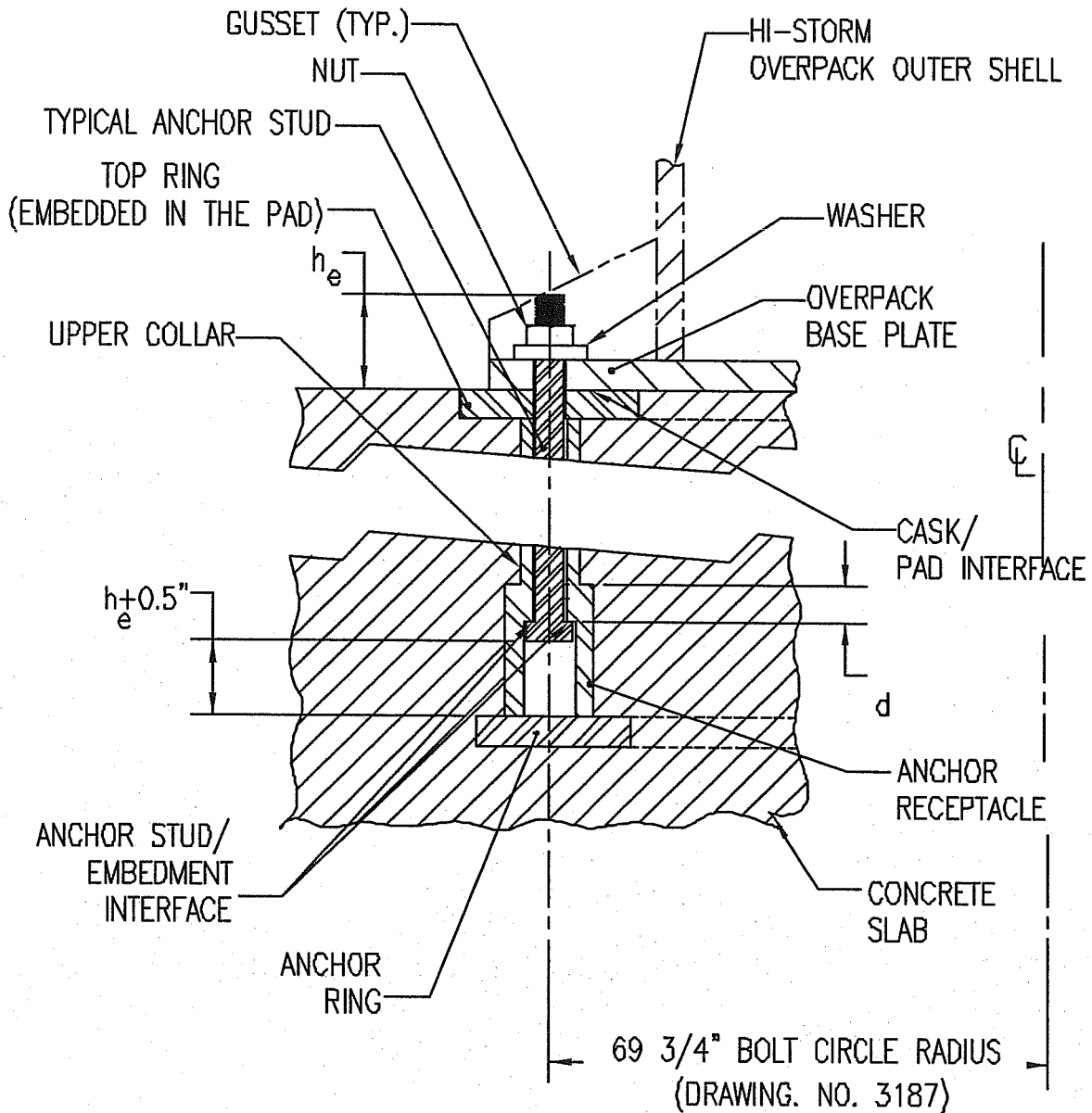

Figure 2.A.1;  
 Typical HI-STORM/ISFSI pad Fastening Detail

Note: Rebars in the ISFSI pad and sub-surface soil/rock continuum not shown.

## Appendix 2.B The Forced Helium Dehydration (FHD) System

### 2.B.1 System Overview

The Forced Helium Dehydration (FHD) system is used to remove the remaining moisture in the MPC cavity after all of the water that can practically be removed through the drain line using a hydraulic pump or an inert gas has been expelled in the water blowdown operation. The FHD system is required to be used for MPCs containing at least one high burnup fuel assembly. The FHD method of moisture removal is optional for all other MPCs.

Expelling the water from the MPC using a conventional pump or a water displacement method using inert gas would remove practically all of the contained water except for the small quantity remaining on the MPC baseplate below the bottom of the drain line and an even smaller adherent amount wetting the internal surfaces. A skid-mounted, closed loop dehydration system will be used to remove the residual water from the MPC such that the partial pressure of the trace quantity of water vapor in the MPC cavity gas is brought down to  $\leq 3$  torr. The FHD system, engineered for this purpose, shall utilize helium gas as the working substance.

The FHD system, schematically illustrated in Figure 2.B.1, can be viewed as an assemblage of four thermal modules, namely, (i) the condensing module, (ii) the demoisurizer module, (iii) the helium circulator module and (iv) the pre-heater module. The condensing module serves to cool the helium/vapor mixture exiting the MPC to a temperature well below its dew point such that water may be extracted from the helium stream. The condensing module is equipped with suitable instrumentation to provide a direct assessment of the extent of condensation that takes place in the module during the operation of the FHD system. The demoisurizer module, engineered to receive partially cooled helium exiting the condensing module, progressively chills the recirculating helium gas to a temperature that is well below the temperature corresponding to the partial pressure of water vapor at 3 torr.

The motive energy to circulate helium is provided by the helium circulator module, which is sized to provide the pressure rise necessary to circulate helium at the requisite rate. The last item, labeled the pre-heater module, serves to pre-heat the flowing helium to the desired temperature such that it is sufficiently warm to boil off any water present in the MPC cavity.

The pre-heater module, in essence, serves to add supplemental heat energy to the helium gas (in addition to the heat generated by the stored SNF in the MPC) so as to facilitate rapid conversion of water into vapor form. The heat input from the pre-heater module can be adjusted in the manner of a conventional electric heater so that the recirculating helium entering the MPC is sufficiently dry and hot to evaporate water, but not unduly hot to place unnecessary thermal burden on the condensing module.

The FHD system described in the foregoing performs its intended function by continuously removing water entrained in the MPC through successive cooling, moisture removal and reheating of the working substance in a closed loop. In a classical system of the FHD genre, the moisture removal operation occurs in two discrete phases. In the beginning of the FHD system's

operation (Phase 1), the helium exiting the MPC is laden with water vapor produced by boiling of the entrained bulk water. The condensing module serves as the principal device to condense out the water vapor from the helium stream in Phase 1. Phase 1 ends when all of the bulk water in the MPC cavity is vaporized. At this point, the operation of the FHD system moves on to steadily lowering the relative humidity and bulk temperature of the circulating helium gas (Phase 2). The demister module, equipped with the facility to chill flowing helium, plays the principal role in the dehydration process in Phase 2.

## 2.B.2 Design Criteria

The design criteria set forth below are intended to ensure that design and operation of the FHD system will drive the partial pressure of the residual vapor in the MPC cavity to  $\leq 3$  torr if the gas has met the specified temperature or dew point value and duration criteria. The FHD system shall be designed to ensure that during normal operation (i.e., excluding startup and shutdown ramps) the following criteria are met:

- i. The temperature of helium gas in the MPC shall be at least 15°F higher than the saturation temperature at coincident pressure.
- ii. The pressure in the MPC cavity space shall be less than or equal to 60.3 psig (75 psia).
- iii. The recirculation rate of helium shall be sufficiently high (minimum hourly throughput equal to ten times the nominal helium mass backfilled into the MPC for fuel storage operations) so as to produce a turbulent flow regime in the MPC cavity.
- iv. The partial pressure of the water vapor in the MPC cavity will not exceed 3 torr. The limit will be met if the gas temperature at the demister outlet is verified by measurement to remain  $\leq 21^\circ\text{F}$  for  $\geq 30$  minutes or if the dew point of the gas exiting the MPC is verified by measurement to remain  $\leq 22.9^\circ\text{F}$  for  $\geq 30$  minutes.

In addition to the above system design criteria, the individual modules shall be designed in accordance with the following criteria:

- i. The condensing module shall be designed to de-vaporize the recirculating helium gas to a dew point of 120°F or less.
- ii. The demister module shall be configured to be introduced into its helium conditioning function after the condensing module has been operated for the required length of time to assure that the bulk moisture vaporization in the MPC (defined as Phase 1 in Section 2.B.1) has been completed.
- iii. The helium circulator shall be sized to effect the minimum flow rate of circulation required by the system design criteria described above.

- iv. The pre-heater module shall be engineered to ensure that the temperature of the helium gas in the MPC meets the system design criteria described above.

### 2.B.3 Analysis Requirements

The design of the FHD system shall be subject to the confirmatory analyses listed below to ensure that the system will accomplish the performance objectives set forth in this FSAR.

- i. System thermal analysis in Phase 1: Characterize the rate of condensation in the condensing module and helium temperature variation under Phase 1 operation (i.e., the scenario where there is some unevaporated water in the MPC) using a classical thermal-hydraulic model wherein the incoming helium is assumed to fully mix with the moist helium inside the MPC.
- ii. System thermal analysis in Phase 2: Characterize the thermal performance of the closed loop system in Phase 2 (no unvaporized moisture in the MPC) to predict the rate of condensation and temperature of the helium gas exiting the condensing and the demohurizer modules. Establish that the system design is capable to ensure that partial pressure of water vapor in the MPC will reach  $\leq 3$  torr if the temperature of the helium gas exiting the demohurizer is predicted to be at a maximum of 21°F for 30 minutes.
- iii. Fuel Cladding Temperature Analysis: A steady-state thermal analysis of the MPC under the forced helium flow scenario shall be performed using the methodology described in HI-STORM 100 FSAR Subsections 4.4.1.1.1 through 4.4.1.1.4 with due recognition of the forced convection process during FHD system operation. This analysis shall demonstrate that the peak temperature of the fuel cladding under the most adverse condition of FHD system operation (design maximum heat load, no moisture, and maximum helium inlet temperature), is below the peak cladding temperature limit for normal conditions of storage for the applicable fuel type (PWR or BWR) and cooling time at the start of dry storage.

### 2.B.4 Acceptance Testing

The first FHD system designed and built for the MPC drying function required by HI-STORM's technical specifications shall be subject to confirmatory testing as follows:

- a. A representative quantity of water shall be placed in a manufactured MPC (or equivalent mock-up) and the closure lid and RVOAs installed and secured to create a hermetically sealed container.
- b. The MPC cavity drying test shall be conducted for the worst case scenario (no heat generation within the MPC available to vaporize water).

- c. The drain and vent line RVOAs on the MPC lid shall be connected to the terminals located in the pre-heater and condensing modules of the FHD system.
- d. The FHD system shall be operated through the moisture vaporization (Phase 1) and subsequent dehydration (Phase 2). The FHD system operation will be stopped after the temperature of helium exiting the demohstrizer module has been at or below 21°F for thirty minutes (nominal). Thereafter, a sample of the helium gas from the MPC will be extracted and tested to determine the partial pressure of the residual water vapor in it. The FHD system will be deemed to have passed the acceptance testing if the partial pressure in the extracted helium sample is less than or equal to 3 torr.

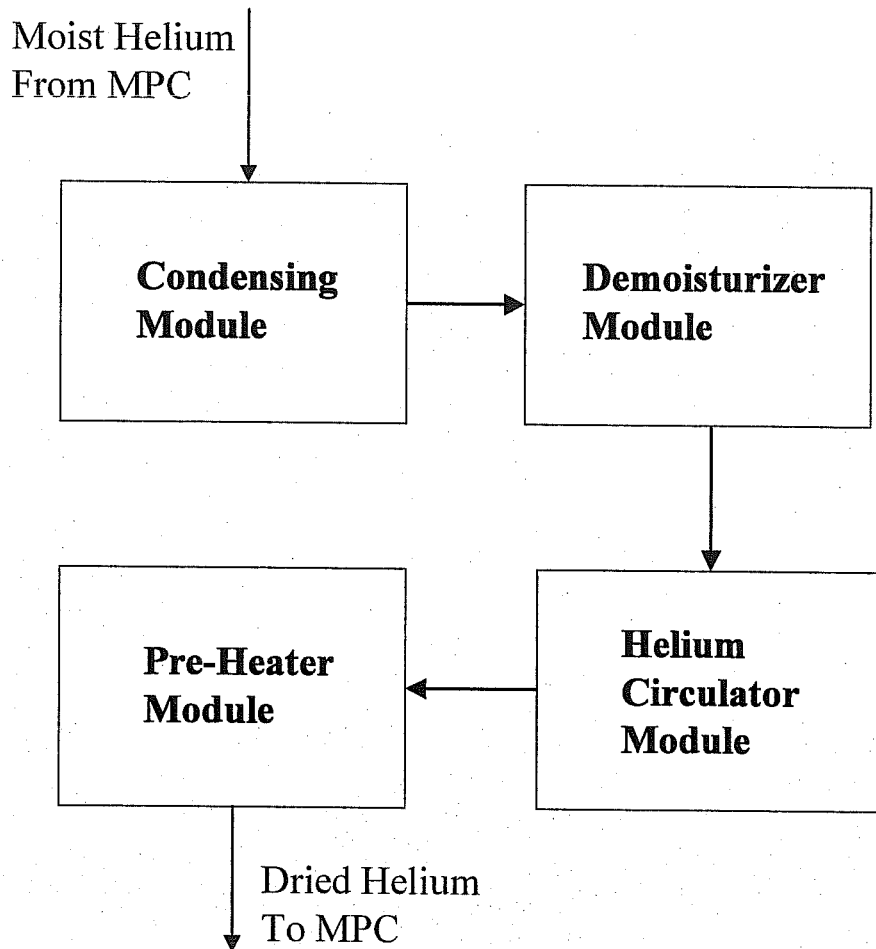

FIGURE 2.B.1: SCHEMATIC OF THE FORCED HELIUM DEHYDRATION SYSTEM



## Appendix 2.C

### The Supplemental Cooling System

#### 2.C.1 Purpose

The Supplemental Cooling System (SCS) will be utilized, as necessary, to maintain the peak fuel cladding temperature below the limit set forth in Chapter 2 of the FSAR during normal short-term operations (as defined in Section 2.2).

#### 2.C.2 General Description and Requirements

The SCS is a water circulation system for cooling the MPC inside the HI-TRAC transfer cask during on-site transport. The system consists of a skid-mounted coolant pump and an air-cooled heat exchanger. During normal SCS operation, heat is removed by water from the HI-TRAC annulus and rejected to the heat sink (ambient air) across the air cooler heat exchange surfaces. The SCS shall be designed to meet the following criteria:

- (i) The pump is sized to limit the coolant temperature rise (from annulus inlet to outlet) to a reasonably low value (20°F) and the air-cooled heat exchanger sized for the design basis heat load at an ambient air temperature of 100°F. The pump and air-cooler fan are powered by electric motors with a backup power supply for uninterrupted operation.
- (ii) The closed loop cooling circuit will utilize a contamination-free fluid medium in contact with the external surfaces of the MPC and inside surfaces of the HI -TRAC transfer cask to minimize corrosion. Figure 2.C.1 shows a typical P&ID for a SCS.
- (iii) The number of active components in the SCS will be minimized.
- (iv) All passive components such as tubular heat exchangers, manually operated valves and fittings shall be designed to applicable standards (TEMA, ANSI).

#### 2.C.3 Thermal/Hydraulic Design Criteria

- (i) The heat dissipation capacity of the SCS shall be equal to or greater than the minimum necessary to ensure that the peak cladding temperature is below the ISG-11, Rev. 3 limit of 400°C (752°F). All heat transfer surfaces in heat exchangers shall be assumed to be fouled to the maximum limits specified in a widely used heat exchange equipment standard such as the Standards of Tubular Exchanger Manufacturers Association.
- (ii) The coolant utilized to extract heat from the MPC shall be high purity water. Anti-freeze may be used to prevent water from freezing if warranted by operating conditions.

#### 2.C.4 Mechanical Requirements

- (i) All pressure boundaries (as defined in the ASME Boiler and Pressure Vessel Code, Section VIII Division 1) shall have pressure ratings that are greater than the maximum system operating pressure by at least 15 psi.
- (ii) All ASME Code components shall comply with Section VIII Division 1 of the ASME Boiler and Pressure Vessel Code.
- (iii) Prohibited Materials

The following materials will not be in contact with the system coolant in the SCS.

- Lead
  - Mercury
  - Sulfur
  - Saran
  - Silastic L8-53
  - Cadmium
  - Tin
  - Antimony
  - Bismuth
  - Mischmetal
  - Neoprene or similar gasket materials made of halogen containing elastomers
  - Phosphorus
  - Zinc
  - Copper and Copper Alloys
  - Rubber-bonded asbestos
  - Nylon
  - Magnesium oxide (e.g., insulation)
  - Materials that contain halogens in amounts exceeding 75 ppm
- (iv) All gasketed and packed joints shall have a minimum design pressure rating of the pump shut-off pressure plus 15 psi.
  - (v) The SCS skid shall be equipped with appropriate lifting lugs to permit its handling by the plant's lifting devices in full compliance with NUREG-0612 provisions.

#### 2.C.5 Regulatory Requirements

The SCS is classified as Important-to-Safety Category B.

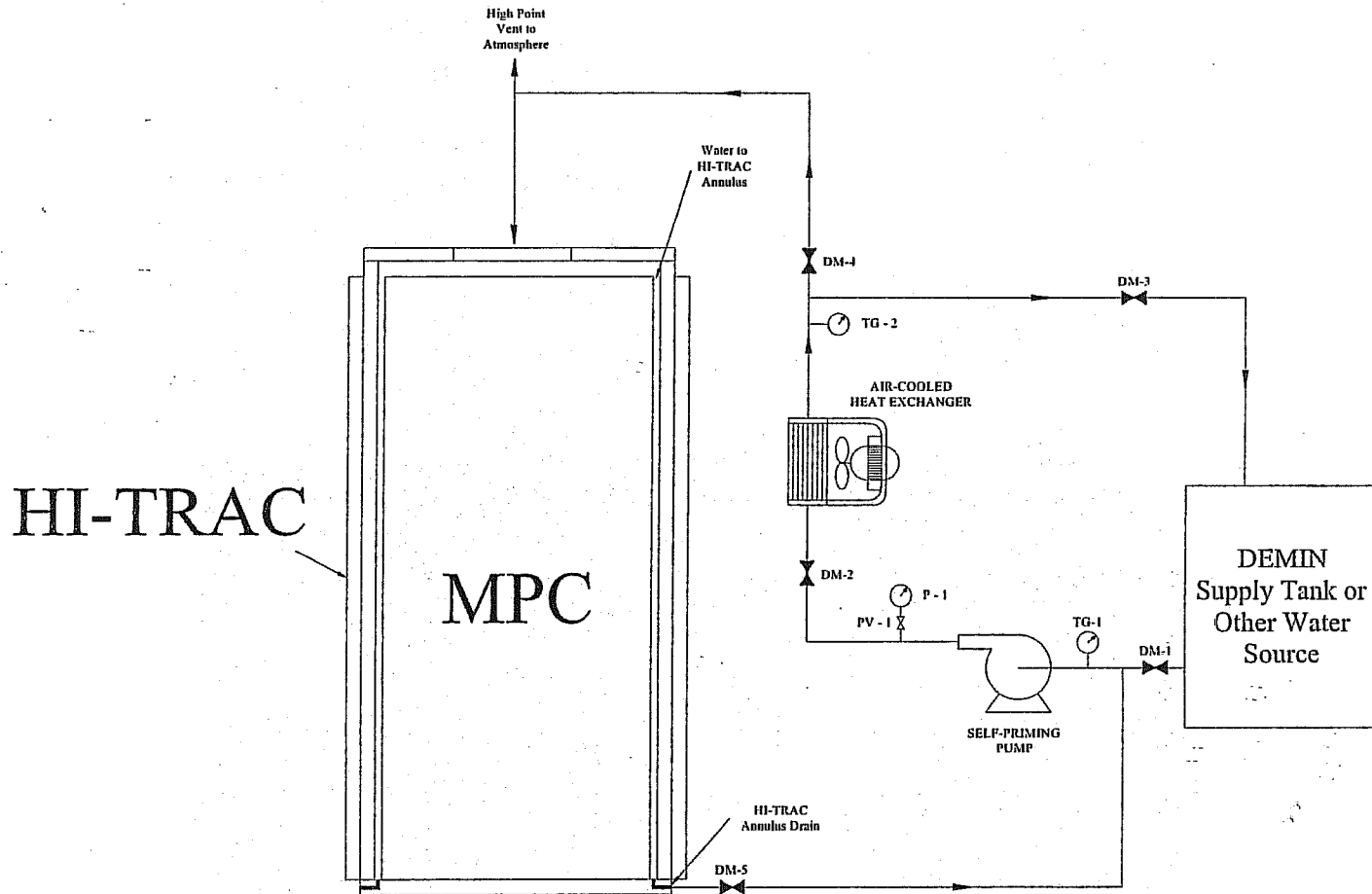

FIGURE 2.C.1: SUPPLEMENTAL COOLING SYSTEM EXAMPLE P&I DIAGRAM

**SUPPLEMENT 2.I**

**(This Section Reserved for Future Use)**

HOLTEC INTERNATIONAL COPYRIGHTED MATERIAL

HI-STORM FSAR  
REPORT HI-2002444

2.I-1

Rev. 6

## SUPPLEMENT 2.II

### PRINCIPAL DESIGN CRITERIA FOR THE HI-STORM 100 SYSTEM FOR IP1

#### 2.II.0 OVERVIEW OF THE PRINCIPAL DESIGN CRITERIA

##### General

A description of the HI-STORM 100 System as expanded for Indian Point Unit 1 (IP1) is provided in Supplement 1.II. The design criteria presented in Section 2.0 for all components are applicable to the HI-STORM 100 System at IP1 unless otherwise noted below. Drawings of the components shortened for IP1 (HI-STORM 100S Version B, MPC-32, and HI-TRAC 100D Version IP1) are provided in Section 1.5.

##### Thermal

The MPC-32 for IP1 is designed for a bounding uniformly distributed thermal source term. Regionalized fuel loading is not considered in the MPC-32 for IP1.

##### Shielding

The HI-TRAC 100D Version IP1 transfer cask provides shielding to maintain occupational exposures ALARA in accordance with 10CFR20, while also maintaining the maximum load on the plant's crane hook to below 75 tons.

#### 2.II.1 SPENT FUEL TO BE STORED

IP1 fuel is authorized for loading into the IP1 MPC-32 as outlined in this supplement. The requirements in this supplement supersede the requirements in Chapter 2 for the MPC-32 for array/class 14x14E. Requirements from Chapter 2 that are not superseded in this supplement remain in effect.

Table 2.1.3 in Chapter 2 provides the acceptable fuel characteristics for the IP1 fuel assemblies, array/class 14x14E, for storage in the HI-STORM 100 System.

##### 2.II.1.1 Intact SNF, Damaged SNF, and Fuel Debris Specifications

Fuel debris from Indian Point Unit 1 is not authorized for storage in the IP1 MPC-32 or IP1 MPC-32F. Section 2.II.1.4 specifies the acceptable limits for IP1 fuel assemblies to be stored in the IP1 MPC-32 or MPC-32F.

In order to simplify the fuel selection and fuel placement in an MPC-32 or MPC-32F at IP1, all IP1 fuel assemblies are required to be stored in a damaged fuel container (DFC). Figure 2.II.1 describes the Holtec designed damaged fuel container for IP1 fuel.

Since the MPC-32 and MPC-32F for IP1 have been shortened, fuel spacers will not be necessary inside the MPC.

#### 2.II.1.2 Radiological Parameters for Design Basis SNF

Indian Point Unit 1 used Antimony-Beryllium as a secondary source during reactor operations. These secondary source devices were installed in the fuel assemblies and replaced a single fuel rod. Supplement 5.II discusses the acceptability of storing these devices.

#### 2.II.1.3 Criticality Parameters for Design Basis SNF

The minimum  $^{10}\text{B}$  areal density in the neutron absorber panels for each MPC model is shown in Table 2.1.15 in Chapter 2.

The criticality analyses for the IP1 specific MPC-32 and MPC-32F were performed without credit for soluble boron in the MPC water during wet loading and unloading operations. Therefore the required soluble boron level in the IP1 MPC-32 or MPC-32F water is 0 ppmb.

#### 2.II.1.4 Summary of Authorized Contents

Table 2.II.1 specifies the limits for Indian Point Unit 1 fuel, array/class 14x14E, for storage in the IP1 MPC-32 and MPC-32F. The limits in these tables are derived from the safety analyses described in the following chapters and supplements of this FSAR. All IP1 fuel assemblies classified as intact or damaged must be stored in damaged fuel containers for storage in the IP1 MPC-32 and IP1 MPC-32F. Indian Point Unit 1 fuel debris is not permitted for storage in these MPCs.

### 2.II.2 HI-STORM 100 DESIGN CRITERIA

#### 2.II.2.1 Handling Accident

A loaded HI-STORM 100S Version B overpack containing Indian Point Unit 1 fuel will be lifted so that the bottom of the cask is at a height less than the vertical lift limit (see Table 2.II.2) above the ground. The use of lifting devices designed in accordance with ANSI N14.6 having redundant drop protection features to lift the loaded overpack will eliminate the lift height limit. The lift height limit is dependent on the characteristics of the impacting surface, which are specified in Table 2.2.9 in Chapter 2. For site-specific conditions, which are not encompassed by Table 2.2.9, the licensee shall evaluate the site-specific conditions to ensure that the drop accident loads do not exceed 45 g's. Even if the site specific conditions are encompassed by Table 2.2.9, the licensee may choose to determine a site specific drop height which ensures that the drop accident loads do not exceed 45 g's. The methodology used in this alternative analysis shall be commensurate with the analyses in Appendix 3.A and shall be reviewed by the Certificate Holder.

The loaded HI-TRAC 100D Version IP1, when lifted in the vertical position outside of the Part 50

facility shall be lifted with devices designed in accordance with ANSI N14.6 and having redundant drop protection features unless a site-specific analysis has been performed to determine a vertical lift height limit. Horizontal lifting of a loaded HI-TRAC 100D Version IP1 is not permitted.

### 2.II.3 SAFETY PROTECTION SYSTEMS

Same as in Section 2.3.

### 2.II.4 DECOMMISSIONING CONSIDERATIONS

Same as in Section 2.4.

### 2.II.5 REGULATORY COMPLIANCE

Same as in Section 2.5.

Table 2.II.1

LIMITS FOR MATERIAL TO BE STORED IN IP1 MPC-32 OR IP1 MPC-32F

PARAMETER	VALUE
Fuel Type	Uranium oxide, PWR intact and damaged fuel assemblies meeting the limits in Table 2.1.3 for the array/class 14x14E
Cladding Type	Stainless Steel (SS)
Maximum Initial Enrichment per Assembly	As specified in Table 2.1.3 for the array/class 14x14E
Post-irradiation Cooling Time and Average Burnup per Assembly	$\geq 30$ years and $\leq 30,000$ MWD/MTU
Decay Heat Per Fuel Storage Location	$\leq 250$ Watts
<i>Other Limits</i>	<ul style="list-style-type: none"> <li>▪ Quantity is limited to up to 32 PWR intact fuel assemblies and/or damaged fuel assemblies.</li> <li>▪ Both intact and damaged fuel assemblies must be stored in a damaged fuel container.</li> <li>▪ Fuel debris is not permitted for storage in IP1 MPC-32 or IP1 MPC-32F.</li> <li>▪ Each fuel assembly may contain a single Antimony-Beryllium secondary source that replaces a fuel rod.</li> </ul>



Table 2.II.2

ADDITIONAL DESIGN INPUT DATA FOR ACCIDENT CONDITIONS

Item	Condition	Value
Vertical Lift Height Limit for a HI-STORM 100S Version B Overpack Loaded With Indian Point Unit 1 Fuel (in.)	Accident	8 <sup>†</sup>
HI-TRAC 100D Version IP1 Transfer Cask Horizontal Lift Height Limit (in.)	Accident	Not permitted

<sup>†</sup> For ISFSI and subgrade design parameter Sets A and B specified in Table 2.2.9 of Chapter 2. Users may also develop a site-specific lift height limit.

- NOTES:  
 1. ALL DIMENSIONS ARE IN INCHES AND ARE APPROXIMATE.  
 2. ALL MATERIAL IS STAINLESS STEEL.

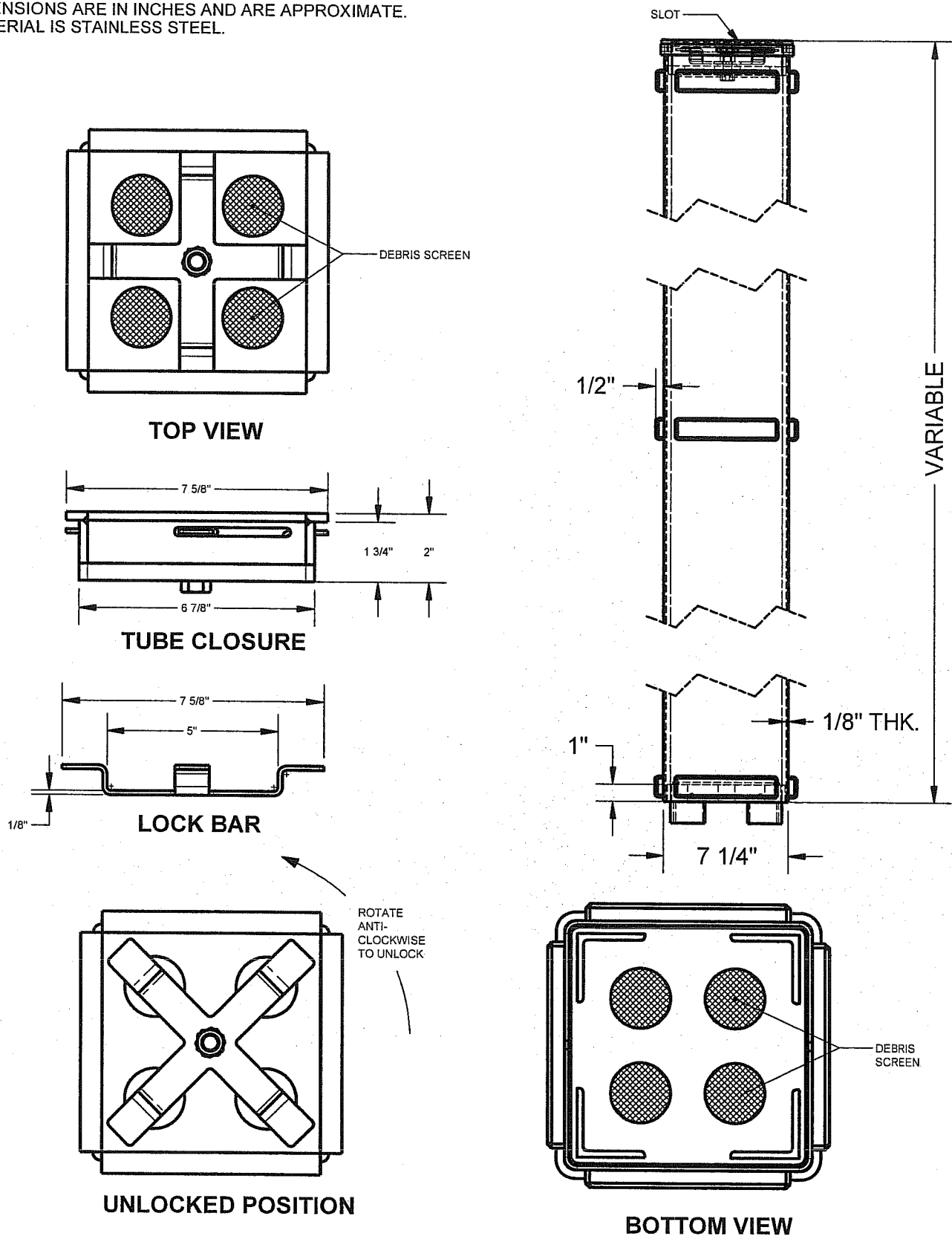

FIGURE 2.II.1; HOLTEC IP1 DAMAGED FUEL CONTAINER FOR PWR SNF IN MPC-32/32F

