

Methodology for Development of Emergency Action Levels

February 2008

ACKNOWLEDGEMENTS

Revision 5 of this Nuclear Energy Institute (NEI) report incorporates Frequently Asked Questions (FAQs) generated by users and developers during conversion from previous classification schemes to NEI 99-01, Rev. 4 and Security Emergency Action Levels (EALs) with the Hostile Action changes endorsed by the Nuclear Regulatory Commission (NRC) in Regulatory Issue Summary RIS 2006-12 on July 19, 2006. The EAL changes are based on numerous suggestions provided by utilities and input provided by the staff of the NRC. NEI acknowledges the valuable input and extensive technical support provided by the members of the EAL FAQ Task Force.

Revision 5 recognized implementation difficulties, interpretations and errors of Revision 4 and was developed through use of a FAQ format where stakeholders submitted concerns to the NEI Task Force and technical solutions were found to better transition the classification process.

NOTICE

This report was prepared as an account of work sponsored by the Nuclear Energy Institute (NEI). Neither NEI nor any of its employees, members, or consultants make any warranty, expressed or implied, or assume any legal liability or responsibility for the accuracy, completeness or usefulness of any information, apparatus, product or process disclosed in this report, or represent that its use would not infringe privately owned rights.

The opinions, conclusions, and recommendations set forth in this report are those of the authors and do not necessarily represent the views of NEI or its employees, members or consultants.

Because NEI is supported in part by federal funds, NEI's activities are subject to Title VI of the Civil Rights Act of 1964, which prohibits discrimination based on race, color, or national origin, and other federal laws and regulations, rules, and orders issued there under prohibiting discrimination. Written complaints of exclusion, denial of benefits or other discrimination of those bases under this program may be filed with the United States Nuclear Regulatory Commission, Washington, DC 20555 or any other appropriate federal regulatory agency or, among others, the Tennessee Valley Authority (TVA), Office of Equal Employment Opportunity, 400 West Summit Hill Drive, Knoxville, TN 37902.

FOREWORD

Revision 5 recognized implementation difficulties, interpretations, and errors of Revision 4 and was developed through use of a FAQ format where stakeholders submitted concerns to the NEI Task Force and technical solutions were found to better transition the classification process.

Revision 5 of this report incorporates the following:

- Frequently Asked Questions (FAQs) generated by users and developers during conversion from previous classification schemes to NEI 99-01, Revision 4;
- Security EALs with the Hostile Action changes endorsed by the NRC in RIS 2006-12 on July 19, 2006;
- Enhanced guidance related to Security EALs to ensure consistency with NEI 03-12;
- Clarification of several EALs to resolve any potential misunderstanding as to the intent of the EAL.

**EAL REVISION TASK FORCE
2006-2007**

Martin Hug
Walter Lee
Chris Boone
Brent Knepper
Kenneth Meade
Monica Ray
Rob Harrsch
Martin Vonk
Steve Tulley
David Stobaugh
Kelly Walker
John Kaminski
John Egdorf
David Young
Michael Davis
Scott McCain

Nuclear Energy Institute
Southern Nuclear Operating Company
Southern Nuclear Operating Company
Exelon Nuclear
First Energy Nuclear Operating Company
Nuclear Management Company
Nuclear Management Company
Nuclear Management Company
Nuclear Management Company
EP Consulting, LLC
Operations Support Services Inc
Constellation Energy
Dominion Energy
FPL Energy, LLC
FPL Energy, LLC
EP Technical Consultants

NRC REVIEW

Michael Norris
Don Johnson
Steve LaVie

U.S. Nuclear Regulatory Commission
U.S. Nuclear Regulatory Commission
U.S. Nuclear Regulatory Commission

TABLE OF CONTENTS

	<u>PAGE</u>
EXECUTIVE SUMMARY	iii
ACRONYMS & ABBREVIATIONS.....	iv
1.0 Methodology for Development of Emergency Action Levels	1
1.1 Background	1
2.0 Changes Incorporated With Revision 5	4
2.1 Section 3.0, Development of Basis for Generic Approach.....	4
2.2 Section 4.0, Human Factors Considerations	4
2.3 Section 5.0, Generic EAL Guidance	4
2.4 Section 5.0, Recognition Category A.....	4
2.5 Section 5.0, Recognition Category C.....	4
2.6 Section 5.0, Recognition Category D.....	4
2.7 Section 5.0, Recognition Category E.....	4
2.8 Section 5.0, Recognition Category F	5
2.9 Section 5.0, Recognition Category H.....	5
2.10 Section 5.0, Recognition Category S.....	5
3.0 Development of Basis for Generic Approach.....	6
3.1 Regulatory Context.....	6
3.2 Definitions Used to Develop EAL Methodology	8
3.3 Differences in Perspective	9
3.4 Recognition Categories	9
3.5 Design Differences	11
3.6 Required Characteristics	11
3.7 Emergency Classification Level Descriptions	12
3.8 Emergency Classification Level Thresholds	13
3.9 Emergency Action Levels	15
3.10 Treatment of Multiple Events and Classification Level Upgrading.....	16
3.11 Emergency Classification Level Downgrading.....	17
3.12 Classifying Transient Events	17
3.13 Operating Mode Applicability.....	17
3.14 BWR Operating Modes (Follow site specific Technical Specifications)	18
3.15 PWR Operating Modes (Follow site specific Technical Specifications)	18
4.0 Human Factors Considerations	19
4.1 Level of Integration of EALs with Plant Procedures.....	19
4.2 Method of Presentation	19
4.3 Symptom-Based, Event-Based, or Barrier-Based EALs.....	20

TABLE OF CONTENTS

	<u>PAGE</u>
5.0 Generic EAL Guidance	21
5.1 Generic Arrangement	21
5.2 Generic Bases	22
5.3 Site Specific Implementation	23
5.4 Definitions.....	24
5.5 Abnormal Rad Levels / Radiological Effluent EALs	27
5.6 Cold Shutdown / Refueling System Malfunction EALs	43
5.7 Permanently Defueled Station EALs	63
5.8 IFSFI EALs	77
5.9 Fission Product Barrier EALs	79
5.10 Hazards and Other Conditions Affecting Plant Safety EALs.....	104
5.11 System Malfunction EALs.....	128
Appendix A: Basis for Radiological Effluent EALs	151
Appendix D: Basis for Permanently Defueled Station EALs	160
Appendix E: Basis for ISFSI EALs.....	163

EXECUTIVE SUMMARY

Revision 5 to NEI 99-01 represents several years of use and implementation of the NEI 99-01 methodology. Initially, portions of Revision 4 were superseded by NRC Bulletin 2005-02 "Emergency Preparedness And Response Actions For Security-Based Events" to immediately implement changes to the security philosophy following the events of September 11, 2001. This process was accomplished using a NEI White Paper "Enhancements to Emergency Preparedness Programs For Hostile Action", May 2005 (Revised November 18, 2005) and endorsed by the NRC in RIS 2006-12 on July 19, 2006. The security changes are formalized with Revision 5.

In order to address development and implementation issues, a FAQ process was used to take input from the industry and the NRC. The NEI 99-01 EAL FAQ Task Force evaluated each concern presented and provided an industry perspective to each. The Task Force presented the recommendations to the NRC for consideration and approval. FAQs that were acceptable are incorporated with this change.

ACRONYMS & ABBREVIATIONS

AC	Alternating Current
APRM	Average Power Range Meter
ATWS	Anticipated Transient Without Scram
B&W	Babcock and Wilcox
BWR	Boiling Water Reactor
CCW	Component Cooling Water
CDE	Committed Dose Equivalent
CE	Combustion Engineering
CFR	Code of Federal Regulations
CTMT/CNMT	Containment
CSF	Critical Safety Function
CSFST	Critical Safety Function Status Tree
DC	Direct Current
DHR	Decay Heat Removal
DOT	Department of Transportation
EAL	Emergency Action Level
ECCS	Emergency Core Cooling System
ECL	Emergency Classification Level
EOF	Emergency Operations Facility
EOP	Emergency Operating Procedure
EPA	Environmental Protection Agency
EPG	Emergency Procedure Guideline
EPIP	Emergency Plan Implementing Procedure
EPRI	Electric Power Research Institute
ERG	Emergency Response Guideline
ESF	Engineered Safety Feature
ESW	Emergency Service Water
FAA	Federal Aviation Administration
FBI	Federal Bureau of Investigation
FEMA	Federal Emergency Management Agency
FSAR	Final Safety Analysis Report
GE	General Emergency
HPCI	High Pressure Coolant Injection
HPSI	High Pressure Safety Injection
IC	Initiating Condition
IPEEE	Individual Plant Examination of External Events (Generic Letter 88-20)
ISFSI	Independent Spent Fuel Storage Installation
Keff	Effective Neutron Multiplication Factor
LCO	Limiting Condition of Operation
LER	Licensee Event Report
LOCA	Loss of Coolant Accident
LPSI	Low Pressure Safety Injection
LWR	Light Water Reactor
MSIV	Main Steam Isolation Valve
MSL	Main Steam Line
mR	milliRoentgen
MW	Megawatt
NEI	Nuclear Energy Institute
NESP	National Environmental Studies Project
NPP	Nuclear Power Plant
NRC	Nuclear Regulatory Commission

ACRONYMS & ABBREVIATIONS (continued)

NSSS	Nuclear Steam Supply System
NORAD	North American Aerospace Defense Command
NOUE	Notification Of Unusual Event
NUMARC	Nuclear Management and Resources Council
OBE	Operating Basis Earthquake
OCA	Owner Controlled Area
ODCM/ODAM	Off-site Dose Calculation (Assessment) Manual
ORO	Off-site Response Organization
PA	Protected Area
PAG	Protective Action Guideline
POAH	Point of Adding Heat
PRA/PSA	Probabilistic Risk Assessment / Probabilistic Safety Assessment
PWR	Pressurized Water Reactor
PSIG	Pounds per Square Inch Gauge
R	Roentgen
RCC	Reactor Control Console
RCIC	Reactor Core Isolation Cooling
RCS	Reactor Coolant System
rem	Roentgen Equivalent Man
RETS	Radiological Effluent Technical Specifications
RPS	Reactor Protection System
RPV	Reactor Pressure Vessel
RVLIS	Reactor Vessel Level Indicating System
RWCU	Reactor Water Cleanup
SBGTS	Stand-By Gas Treatment System
SBO	Station Blackout
SG	Steam Generator
SI	Safety Injection
SPDS	Safety Parameter Display System
SRO	Senior Reactor Operator
SSE	Safe Shutdown Earthquake
TEDE	Total Effective Dose Equivalent
TOAF	Top of Active Fuel
TSC	Technical Support Center
WE	Westinghouse Electric
WOG	Westinghouse Owners Group

1.0 Methodology for Development of Emergency Action Levels

1.1 Background

The historical background for the development of NEI 99-01, "Methodology for Development of Emergency Action Levels" is contained in Revision 4.

Nuclear utilities must respond to a formal set of threshold conditions that require plant personnel to take specific actions with regard to notifying state and local governments and the public when certain off-normal indicators or events are recognized. Emergency classification levels are defined in 10 CFR 50. Levels of response and the conditions leading to those responses are defined in joint NRC/FEMA guidelines contained in Appendix 1 of NUREG-0654/ FEMA-REP-1, Rev. 1, "Criteria for Preparation and Evaluation of Radiological Emergency Response Plans and Preparedness in Support of Nuclear Power Plants," November 1980.

The EAL Task Force developed a systematic approach and supporting basis for EAL development. This methodology developed a set of generic EAL guidelines, together with the basis for each, such that they could be used and adapted by each utility on a consistent basis. The review of the industry's experiences with EALs, in conjunction with regulatory considerations, was applied directly to the development of this generic set of EAL guidelines. The generic guidelines were intended to clearly define conditions that represent increasing risk to the public and can give consistent classifications when applied at different sites.

The guidance presented here is not intended to be applied to plants as-is. It is intended to give the user the logic for developing site specific EALs (i.e., instrument readings, etc.) using site specific EAL presentation methods (formats). Basis information is provided to aid station personnel in preparation of their own site specific EALs, to provide necessary information for training, and for explanation to state and local officials. In addition, state and local requirements have not been reflected in the generic guidance and should be considered on a case-by-case basis with appropriate state and local emergency response organizations.

It is important that the NEI EALs be treated as an integrated package. Selecting only portions of this guidance for use in developing site specific EALs could lead to inconsistent or incomplete EALs unless explicitly allowed.

Although the basic concerns with barrier integrity and the major safety problems of nuclear power plants are similar across plant types, design differences will have a substantial effect on EALs. The major differences are found between a BWR and a PWR. In these cases, EAL guidelines unique to BWRs and PWRs must be specified. Even among PWRs, however, there are substantial differences in design and in types of containment used. There is enough commonality among plants that many ICs will be the same or very similar. However, others will have to match plant features and safety system designs that are unique to the plant type or even to the specific plant. The EAL Task Force believes that there is sufficient information provided in the basis of the EALs to allow the EALs to be implemented at plants from all NSSS LWR vendors. However, this generic guidance is not considered to be applicable to advanced LWR designs or site radioactive material storage facilities.

The original EAL Task Force identified eight characteristics that were to be incorporated into model EALs. Experience to date has shown these considerations to be VALID. These were:

- (1) Consistency (i.e., the EALs would lead to similar decisions under similar circumstances at different plants);
- (2) Human engineering and user friendliness;

- (3) Potential for classification upgrade only when there is an increasing threat to public health and safety;
- (4) Ease of upgrading and downgrading;
- (5) Thoroughness in addressing, and disposing of, the issues of completeness and accuracy raised regarding NUREG-0654, Appendix 1;
- (6) Technical completeness and appropriateness for each classification level;
- (7) A logical progression in classification for combinations of multiple events;
- (8) Objective, observable values.

Based on the information gathered and reviewed, the Task Force has developed generic EAL guidance. Because of the wide variety of presentation methods (formats) used at different utilities, the Task Force believes that specifying guidance as to what each IC and EAL should address, and including sufficient basis information for each EAL will best assure uniformity of approach. The information is presented by Recognition Category:

- A - Abnormal Rad Levels/Radiological Effluent
- C - Cold Shutdown / Refueling System Malfunction
- D - Permanently Defueled Station
- E - Independent Spent Fuel Storage Installations (ISFSI)
- F - Fission Product Barrier
- H - Hazards and Other Conditions Affecting Plant Safety
- S - System Malfunction

Each of the EAL guides in Recognition Categories A, C, D, E, H, and S is structured in the following way:

- Recognition Category - As described above.
- Emergency Classification Levels - NOUE, Alert, Site Area Emergency or General Emergency.
- Initiating Condition - Symptom- or Event-Based, Generic Identification and Title.
- Operating Mode Applicability - Power Operation, Hot Standby, Hot Shutdown, Cold Shutdown, Refueling, Defueled, All, or Not Applicable.
- Example Emergency Action Level(s) corresponding to the IC.
- Basis information for plant specific readings and factors that may relate to changing the generic IC or EAL to a different emergency classification level, such as for Loss of All AC Power.
- EAL developer information – Information used to aid licensees in the development of site specific EALs.

For Recognition Category F, the EAL information is presented in a matrix format. The presentation method was chosen to clearly show the synergism among the EALs and to support more accurate dynamic assessments. For category F, the EALs are arranged by safety function, or fission product barrier. Classifications are based on various combinations of function or barrier challenges.

The EAL Guidance has the primary threshold for NOUE as operation outside the safety envelope for the plant as defined by plant technical specifications, including LCOs and Action Statement Times. In addition, certain precursors of more serious events such as loss of offsite AC power and earthquakes are included in NOUE EALs. This provides a clear demarcation

between the lowest emergency classification level and "non-emergency" notifications specified by 10 CFR 50.72.

2.0 Changes Incorporated With Revision 5

This section summarizes the more significant changes made to the EAL methodology with Revision 5. This section is not intended to be a complete tabulation of changes. Minor editorial changes were made in the interest of clarity and/or consistent formatting. These changes are not tabulated herein.

2.1 Section 3.0, Development of Basis for Generic Approach

The significant portions of Section 3.0 were retained for developers changing from NUREG 0654 to NEI 99-01, Rev 5 EAL methodology. Developer notes were differentiated in the bases by brackets and italic font.

2.2 Section 4.0, Human Factors Considerations

Words that could be confused with similar sounding words were replaced in EALs, e.g., “rise and drop” replaced “increase and decrease.” Similarly, mathematical symbols were replaced with text, e.g., “greater than or equal to” replaced “ \geq ”. Information previously contained in the EAL Basis section that could reasonably alter how, or when, an EAL is declared have been incorporated into the example EALs.

2.3 Section 5.0, Generic EAL Guidance

The Security specific definitions have been added. Several definitions that are no longer used in this document have been removed. Sections of the basis have been designated as developer information and a paragraph explaining the use of this information was added. Additional information regarding site specific implementation was added in response to numerous questions received during utility implementation efforts. EAL guidance is now consistent with NEI 03-12.

2.4 Section 5.0, Recognition Category A

FAQs 2006-13 (AA2) and -25 (AA3) were implemented.

2.5 Section 5.0, Recognition Category C

FAQs 2006-01 and -08 (CA1), 2006-04 and -18 (CA3), 2006-06 and -07 (CA2), 2006-09 and -10 (CS1), 2006-12 (CU4), 2006-14 (CU1), 2006-15 (CU5), 2006-17 (CU3) and 2006-19 (CG1) were implemented. CU5 was deleted. CA1 and CA2 were combined due to the similarity between BWR and PWR EALs. CS1 and CS2 were combined due to the similarity between the two threshold values and ICs.

2.6 Section 5.0, Recognition Category D

No significant changes.

2.7 Section 5.0, Recognition Category E

Deleted E-HU2 in accordance with NRC Bulletin 2005-02 “Emergency Preparedness And Response Actions For Security-Based Events” and NEI White paper “Enhancements to Emergency Preparedness Programs For Hostile Action”, May 2005 (Revised November 18, 2005) as endorsed by the NRC in RIS 2006-12 on July 19, 2006.

2.8 Section 5.0, Recognition Category F

FAQ 2006-20 (BWR Containment Loss 3) was implemented. A logic table was added to aid in understanding the logic progression.

2.9 Section 5.0, Recognition Category H

FAQs 2006-22 (HU1), 2006-23 (HU3) and 2006-24 (HA3) were implemented. HA7 and HA8 were combined and renumbered as HA4 for consistency. HU4 was reworded to include a definition for SECURITY CONDITION. HU1.3 (vehicle crash) was deleted.

2.10 Section 5.0, Recognition Category S

FAQs 2006-02 (SU1), 2006-03 (SS1) and 2006-16 (SG1) were implemented. Deleted SS4.

Some of the Recognition Category S IC/EALs that addressed shutdown events were incorporated into the Recognition Category C via NEI 99-01 Rev. 4. The EALs affected include SU1, SU4, SU5, SU6, SU7, SU8, SA1, SA3, and SS5. EALs SU7, SA1, SA3, and SS5 have been deleted. In order to preserve consistency with Revision 3, the IC designations, e.g., AU1, SS1, etc., have not been revised. Because of this, there are gaps in the IC designation sequences. The initiating condition matrices for each recognition category were re-arranged slightly to align event progressions where possible. While the individual ICs are presented in sequence by IC designator, the IC entries in the initiating condition matrices may not be in sequence.

3.0 Development of Basis for Generic Approach

3.1 Regulatory Context

Title 10, Code of Federal Regulations, Part 50 provides the regulations that govern emergency preparedness at nuclear power plants. Nuclear power reactor licensees are required to have NRC-approved "emergency response plans" for dealing with "radiological emergencies." The requirements call for both onsite and offsite emergency response plans, with the offsite plans being those approved by FEMA and used by the State and local authorities. This document deals with the utilities' approved onsite plans and procedures for response to radiological emergencies at nuclear power plants, and the links they provide to the offsite plans.

Section 50.47 of Title 10 of the Code of Federal Regulations (10 CFR 50.47), entitled "Emergency Plans," states the requirement for such plans. Part (a)(1) of this regulation states that "no operating license will be issued unless a finding is made by NRC that there is reasonable assurance that adequate protective measures can and will be taken in the event of a radiological emergency."

The major portion of 10 CFR 50.47 lists "standards" that emergency response plans must meet. The standards constitute a detailed list of items to be addressed in the plans. Of particular importance to this project is the fourth standard, which addresses "Emergency Classification Level" and "Emergency Action Levels." These terms, however, are not defined in the regulation.

10 CFR 50.54, "Conditions of licenses," emphasizes that power reactor licensees must "follow, and maintain in effect, emergency plans which meet the standards in Part 50.47(b) and the requirements in Appendix E to this part." The remainder of this part deals primarily with required implementation dates.

10 CFR 50.54(q) allows licensees to make changes to emergency plans without prior Commission approval only if: (a) the changes do not decrease the effectiveness of the plans and (b) the plans, as changed, continue to meet 10 CFR 50.47(b) standards and 10 CFR 50 Appendix E requirements. The licensee must keep a record of any such changes. Proposed changes that decrease the effectiveness of the approved emergency plans may not be implemented without application to and approval by the Commission.

10 CFR 50.72 deals with immediate notification requirements for operating nuclear power reactors. The "immediate" notification section actually includes three types of reports: (1) immediately after notification of State or local agencies (for classifiable emergency events); (2) one-hour reports; and, (3) four-hour reports.

Although 10 CFR 50.72 contains significant detail, it does not define either "Emergency Classification Level" or "Emergency Action Level." But one-hour and four-hour reports are listed as "non-emergency events," namely, those which are "not reported as a declaration of an Emergency Class." Certain 10 CFR 50.72 events can also meet the Notification of Unusual Event emergency classification level if they are precursors of more serious events. These situations also warrant anticipatory notification of state and local officials (see Section 3.7, "Emergency Classification Level Descriptions").

By footnote, the reader is directed from 10 CFR 50.72 to 10 CFR 50 Appendix E, for information concerning "Emergency Classes."

10 CFR 50.73 describes the "Licensee event report system," which requires submittal of follow-up written reports within thirty days of required notification of NRC.

10 CFR 50 Appendix E, Section B, "Assessment Actions," mandates that emergency plans must contain "emergency action levels." EALs are to be described for: (1) determining the need for notification and participation of various agencies, and (2) determining when and what type of protective measures should be considered. Appendix E continues by stating that the EALs are to be based on: (1) in-plant conditions; (2) in-plant instrumentation; (3) onsite monitoring; and (4) offsite monitoring.

10 CFR 50 Appendix E, Section C, "Activation of Emergency Organization," also addresses "emergency classes" and "emergency action levels." This section states that EALs are to be based on: (1) onsite radiation monitoring information; (2) offsite radiation monitoring information; and, (3) readings from a number of plant sensors that indicate a potential emergency, such as containment pressure and the response of the Emergency Core Cooling System. This section also states that "emergency classes" shall include: (1) Notification of Unusual Events (NOUEs), (2) Alert, (3) Site Area Emergency, and (4) General Emergency.

These regulations are supplemented by various regulatory guidance documents. A significant document that has dealt specifically with EALs is NUREG-0654/FEMA-REP-1, "Criteria for Preparation and Evaluation of Radiological Emergency Response Plans and Preparedness in Support of Nuclear Power Plants," October 1980.

Recognition Category D (Permanently Defueled Station) is based on the assumption that the spent fuel was generated by an operating nuclear power station under a 10 CFR 50 license that has ceased operations and intends to store the spent fuel for some period of time. The emergency classification levels for Recognition Category D are those provided by NUREG 0654/FEMA Rep.1. The Unusual Event classifications are provided as an increased awareness for abnormal conditions. The Alert classifications are specific to the actual or potential effects on the spent fuel in storage.

In order for Permanently Defueled Stations to relax their existing emergency plan requirements these stations must verify that credible events cannot result in significant radiological releases beyond the site boundary. It is expected that this verification will confirm that the source term and motive force available in the permanently defueled condition is insufficient to warrant classifications of Site Area Emergency or General Emergency levels. Analyses for the credible design basis accidents are provided in the SAR.

Recognition Category E (ISFSI) is applicable to licensees using their 10 CFR 50 emergency plan to fulfill the requirements of 10 CFR 72.32. Recognition Category E is not applicable to stand alone ISFSIs, Monitored Retrieval Storage Facilities (MRS), or ISFSIs that may process and/or repackage spent fuel. The emergency classification levels for Recognition Category E are those provided by NUREG 0654/FEMA Rep.1 in accordance with 10 CFR 50.47. The classification of an ISFSI event under provisions of a 10 CFR 50.47 emergency plan should be consistent with the definitions of the emergency classification levels as used by that plan. A site specific analysis would make this determination, but in most cases it is expected that classification of an NOUE would be appropriate. It is expected that the initiating conditions germane to a 10 CFR 72.32 emergency plan (described in NUREG-1567) are subsumed within 10 CFR 50.47 emergency plan's classification scheme.

3.2 Definitions Used to Develop EAL Methodology

Based on the above review of regulations, review of common utility usage of terms, discussions among Task Force members, and existing published information, the following definitions apply to the generic EAL methodology:

EMERGENCY CLASSIFICATION LEVEL: One of a minimum set of names or titles established by the NRC for grouping off normal nuclear power plant conditions according to (1) their relative radiological seriousness, and (2) the time-sensitive on-site and off-site radiological emergency preparedness actions necessary to respond to such conditions. The existing radiological emergency classification levels, in ascending order of seriousness, are called:

- (Notification of) Unusual Event (UE)
- Alert
- Site Area Emergency (SAE)
- General Emergency (GE)

INITIATING CONDITION (IC): One of a predetermined subset of nuclear power plant conditions where either the potential exists for a radiological emergency, or such an emergency has occurred.

Discussion: In NUREG-0654, the NRC introduced, but does not define, the term "initiating condition." Since the term is commonly used in nuclear power plant emergency planning, the definition above has been developed and combines both regulatory intent and the greatest degree of common usage among utilities.

Defined in this manner, an IC is an emergency condition which sets it apart from the broad class of conditions that may or may not have the potential to escalate into a radiological emergency. It can be a continuous, measurable function that is outside technical specifications, such as elevated RCS temperature or falling reactor coolant level (a symptom). It also encompasses occurrences such as FIRE (an event) or reactor coolant pipe failure (an event or a barrier breach).

EMERGENCY ACTION LEVEL (EAL): A pre-determined, site specific, observable threshold for a plant IC that places the plant in a given emergency classification level. An EAL can be: an instrument reading; an equipment status indicator; a measurable parameter (on-site or off-site); a discrete, observable event; results of analyses; entry into specific emergency operating procedures; or another phenomenon which, if it occurs, indicates entry into a particular emergency classification level.

Discussion: The term "emergency action level" has been defined by example in the regulations, as noted in the above discussion concerning regulatory background. The term had not, however, been defined operationally in a manner to address all contingencies.

There are times when an EAL will be a threshold point on a measurable continuous function, such as a primary system coolant leak that has exceeded technical specifications for a specific plant.

At other times, the EAL and the IC will coincide, both identified by a discrete event that places the plant in a particular emergency classification level. For example, "Train Derailment On-site" is an example of an "NOUE" IC in NUREG-0654 that also can be an event based EAL.

3.3 Differences in Perspective

The purpose of this effort is to define a methodology for EAL development that will better assure a consistent emergency classification commensurate with the level of risk. The approach must be easily understood and applied by the individuals responsible for on-site and off-site emergency preparedness and response. In order to achieve consistent application, this recommended methodology must be accepted at all levels of application (e.g., licensed operators, health physics personnel, facility managers, off-site emergency agencies, NRC and FEMA response organizations, etc.).

Commercial nuclear facilities are faced with a range of public service and public acceptance pressures. It is of utmost importance that emergency regulations be based on as accurate an assessment of the risk as possible. There are evident risks to health and safety in understating the potential hazard from an event. However, there are risks and costs to alerting the public to an emergency that exceeds the true threat. This is true at all levels, but particularly if evacuation is recommended.

3.4 Recognition Categories

ICs and EALs can be grouped in one of several schemes. This generic classification scheme incorporates symptom-based, event-based, and barrier-based ICs and EALs.

The symptom based category for ICs and EALs refers to those indicators that are measurable over some continuous spectrum, such as core temperature, coolant levels, containment pressure, etc. When one or more of these indicators begin to show off-normal readings, reactor operators are trained to identify the probable causes and potential consequences of these "symptoms" and take corrective action. The level of seriousness these symptoms indicate depends on the degree to which they have exceeded technical specifications, the other symptoms or events that are occurring contemporaneously, and the capability of the licensed operators to gain control and bring the indicator back to safe levels.

Event based EALs and ICs refer to occurrences with potential safety significance, such as the failure of a high pressure safety injection pump, a safety valve failure, or a loss of electric power to some part of the plant. The range of seriousness of these "events" is dependent on the location, number of contemporaneous events, remaining plant safety margin, etc.

Barrier based EALs and ICs refer to the level of challenge to principal barriers used to assure containment of radioactive materials contained within a nuclear power plant. For radioactive materials that are contained within the reactor core, these barriers are: fuel cladding, reactor coolant system pressure boundary, and containment. The level of challenge to these barriers encompasses the extent of damage (loss or potential loss) and the number of barriers concurrently under challenge. In reality, barrier based EALs are a subset of symptom based EALs that deal with symptoms indicating fission product barrier challenges. These barrier based EALs are primarily derived from Emergency Operating Procedure (EOP) Critical Safety Function (CSF) Status Tree Monitoring (or their equivalent). Challenge to one or more barriers generally is initially identified through instrument readings and periodic sampling. Under present barrier-based EALs, deterioration of the reactor coolant system pressure boundary or the fuel clad barrier usually indicates an Alert condition, two barriers under challenge a Site Area Emergency, and loss of two barriers with the third barrier under challenge is a General Emergency. The fission product barrier table described in Section 5-F is a hybrid approach that recognizes that some events may represent a challenge to more than one barrier, and that the containment barrier is weighted less than the reactor coolant system pressure boundary and the fuel clad barriers.

Symptom based ICs and EALs are most easily identified when the plant is in a normal startup, operating or hot shutdown mode of operation, with all of the barriers in place and the plant's instrumentation and emergency safeguards features fully operational as required by technical specifications. It is under these circumstances that the operations staff has the most direct information of the plant's systems, displayed in the main control room. As the plant moves through the decay heat removal process toward cold shutdown and refueling, barriers to fission products are reduced (i.e., reactor coolant system pressure boundary may be open), and fewer of the safety systems required for power operation are required to be fully operational. Under these plant operating modes, the identification of an IC in the plant's operating and safety systems becomes more event based, as the instrumentation to detect symptoms of a developing problem may not be fully effective; and engineered safeguards systems, such as the Emergency Core Cooling System (ECCS), are partially disabled as permitted by the plant's Technical Specifications.

Barrier based ICs and EALs also are heavily dependent on the ability to monitor instruments that indicate the condition of plant operating and safety systems. Fuel cladding integrity and reactor coolant levels can be monitored through several indicators when the plant is in a normal operating mode, but this capability is much more limited when the plant is in a refueling mode, when many of these indicators are disconnected or off-scale. The need for this instrumentation is lessened, however, and alternate instrumentation is placed in service when the plant is shut down.

It is important to note that in some operating modes there may not be definitive and unambiguous indicators of containment integrity available to control room personnel. For this reason, barrier-based EALs should not place undue reliance on assessments of containment integrity in all operating modes. Generally, Technical Specifications relax maintaining containment integrity requirements in shutdown or refuel modes in order to provide flexibility in performance of specific tasks during shutdown conditions. Containment pressure and temperature indications may not increase if there is a pre-existing breach of containment integrity. At most plants, a large portion of the containment's exterior cannot be monitored for leakage by radiation monitors.

Several categories of emergencies have no instrumentation to indicate a developing problem, or the event may be identified before any other indications are recognized. A reactor coolant pipe could break; FIRE alarms could sound; radioactive materials could be released; and any number of other events could occur that would place the plant in an emergency condition with little warning. For emergencies related to the reactor system and safety systems, the ICs shift to an event based scheme as the plant mode moves toward cold shutdown and refueling modes. For non-radiological events, such as FIRE, external floods, wind loads, etc., as described in NUREG-0654 Appendix 1, event based ICs are the norm.

In many cases, a combination of symptom, event and barrier based ICs will be present as an emergency develops. In a LOCA, for example:

- Coolant level is dropping; (symptom)
- There is a leak of some magnitude in the system (pipe break, safety valve stuck open) that exceeds plant capabilities to make up the loss; (barrier breach or event)
- Core (coolant) temperature is rising; (symptom) and
- At some level, fuel failure begins with indicators such as high off-gas, high coolant activity samples, etc. (barrier breach or symptom)

3.5 Design Differences

Although the basic concerns with barrier integrity and the major safety problems of nuclear power plants are similar across plant types, design differences will have a substantial effect on EALs. The major differences are found between a BWR and a PWR. In these cases, EAL guidelines unique to BWRs and PWRs must be specified. Even among PWRs, however, there are substantial differences in design and in types of containment used.

There is enough commonality among plants that many ICs will be the same or very similar. However, others will have to match plant features and safety system designs that are unique to the plant type or even to the specific plant. The EAL Task Force believes that there is sufficient information provided in the basis of the EALs to allow the EALs to be implemented at plants from all NSSS LWR vendors. Licensees implementing design differences not addressed in this document will have to consider the applicable failure mechanisms involved when developing site specific EALs. (Example: Licensees implementing Digital Instrumentation & Control (I&C)).

This generic guidance is not considered applicable to advanced LWR designs or site radioactive material storage facilities.

3.6 Required Characteristics

Eight characteristics that should be incorporated into site specific EALs are identified below:

- (1) Consistency (i.e., the EALs would lead to similar decisions under similar circumstances at different plants);
- (2) Human engineering and user friendliness;
- (3) Potential for classification upgrade only when there is an increasing threat to public health and safety;
- (4) Ease of upgrading and downgrading;
- (5) Thoroughness in addressing, and disposing of, the issues of completeness and accuracy raised regarding NUREG-0654 Appendix 1;
- (6) Technical completeness for each classification level;
- (7) A logical progression in classification for multiple events; and
- (8) Objective, observable values.

EAL development methodology should pay careful attention to these eight characteristics to assure that all are addressed in the development of site specific EALs. The most pervasive and complex of the eight is the first "consistency." The common denominator that is most appropriate for measuring consistency among ICs and EALs is relative risk. The approach taken in the development of these EALs is based on risk assessment to set the boundaries of the emergency classification levels and assure that all EALs that trigger that emergency classification level are in the same range of relative risk. Precursor conditions of more serious emergencies also represent a potential risk to the public and must be appropriately classified.

3.7 Emergency Classification Level Descriptions

There are three considerations related to emergency classification levels. These are:

- (1) The potential impact on radiological safety, either as known now or as can be reasonably projected;
- (2) How far the plant is beyond its predefined design, safety, and operating envelopes; and
- (3) Whether or not conditions that threaten health are expected to be confined to within the site boundary.

The ICs deal explicitly with radiological safety impact by escalating from levels corresponding to releases within regulatory limits to releases beyond EPA Protective Action Guideline (PAG) plume exposure levels. In addition, the "Discussion" sections below include off-site dose consequence considerations that were not included in NUREG-0654 Appendix 1.

NOTIFICATION OF UNUSUAL EVENT (NOUE):

Events are in progress or have occurred which indicate a potential degradation of the level of safety of the plant or indicate a security threat to facility protection has been initiated. No releases of radioactive material requiring off-site response or monitoring are expected unless further degradation of safety systems occurs.

Discussion: Potential degradation of the level of safety of the plant is indicated primarily by exceeding plant technical specification Limiting Condition of Operation (LCO) allowable action statement time for achieving required mode change. Precursors of more serious events should also be included because precursors do represent a potential degradation in the level of safety of the plant. Minor releases of radioactive materials are included. In this emergency classification level, however, releases do not require monitoring or off-site response.

ALERT:

Events are in progress or have occurred which involve an actual or potential substantial degradation of the level of safety of the plant or a security event that involves probable life threatening risk to site personnel or damage to site equipment because of HOSTILE ACTION. Any releases are expected to be limited to small fractions of the EPA PAG exposure levels.

Discussion: Rather than discussing the distinguishing features of "potential degradation" and "potential substantial degradation," a comparative approach would be to determine whether increased monitoring of plant functions is warranted at the Alert level as a result of safety system degradation. This addresses the operations staff's need for help, independent of whether an actual decrease in plant safety is determined. This increased monitoring can then be used to better determine the actual plant safety state, whether escalation to a higher emergency classification level is warranted, or whether de-escalation or termination of the emergency classification level declaration is warranted. Dose consequences from these events are small fractions of the EPA PAG plume exposure levels.

SITE AREA EMERGENCY (SAE):

Events are in progress or have occurred which involve actual or likely major failures of plant functions needed for protection of the public or HOSTILE ACTION that results in intentional damage or malicious acts; 1) toward site personnel or equipment that could lead to the likely failure of or; 2) that prevent effective access to, equipment needed for the protection of the public. Any releases are not expected to result in exposure levels which exceed EPA PAG exposure levels beyond the site boundary.

Discussion: The discriminator (threshold) between Site Area Emergency and General Emergency is whether or not the EPA PAG plume exposure levels are expected to be exceeded outside the site boundary. This threshold, in addition to dynamic dose assessment considerations discussed in the EAL guidelines, clearly addresses NRC and off-site emergency response agency concerns as to timely declaration of a General Emergency.

GENERAL EMERGENCY (GE):

Events are in progress or have occurred which involve actual or IMMINENT substantial core degradation or melting with potential for loss of containment integrity or HOSTILE ACTION that results in an actual loss of physical control of the facility. Releases can be reasonably expected to exceed EPA PAG exposure levels off-site for more than the immediate site area.

Discussion: The bottom line for the General Emergency is whether evacuation or sheltering of the general public is indicated based on EPA PAGs, and therefore should be interpreted to include radionuclide release regardless of cause. In addition, it should address concerns as to uncertainties in systems or structures (e.g. containment) response, and also events such as waste gas tank releases and severe spent fuel pool events postulated to occur at high population density sites. To better assure timely notification, EALs in this category must primarily be expressed in terms of plant function status, with secondary reliance on dose projection. In terms of fission product barriers, loss of two barriers with loss or potential loss of the third barrier constitutes a General Emergency.

3.8 Emergency Classification Level Thresholds

The most common bases for establishing these boundaries are the technical specifications and setpoints for each plant that have been developed in the design basis calculations and the Final Safety Analysis Report (FSAR).

For those conditions that are easily measurable and instrumented, the boundary is likely to be the EAL (observable by plant staff, instrument reading, alarm setpoint, etc.) that indicates entry into a particular emergency classification level. For example, the main steam line radiation monitor may detect high radiation that triggers an alarm. That radiation level also may be the setpoint that closes the Main Steam Isolation Valves (MSIV) and initiates the reactor trip/scram. This same radiation level threshold, depending on plant specific parameters, also may be the appropriate EAL for a direct entry into an emergency classification level.

In addition to the continuously measurable indicators, such as coolant temperature, coolant levels, leak rates, containment pressure, etc., the FSAR provides indications of the consequences associated with design basis events. Examples would include steam pipe breaks, MSIV malfunctions, and other anticipated events that, upon occurrence, place the plant immediately into an emergency classification level.

Another approach for defining these boundaries is the use of a plant specific probabilistic safety assessment (PSA - also known as probabilistic risk analysis, PRA). PSAs have been completed

for all individual plants PSAs can be used as a good first approximation of the relevant ICs and risk associated with emergency conditions for existing plants. Each plant has an Individual Plant Evaluation (IPE) and an Individual Plant Evaluation for External Events (IPEEE). Generic insights from a PSA/ PRA, the IPE, IPEEE and related severe accident assessments which apply to EALs and emergency classification level determinations are:

1. Core damage frequency at many BWRs is dominated by sequences involving prolonged loss of all AC power. In addition, prolonged loss of all AC power events are extremely important at PWRs. This would indicate that should this occur, and AC power is not restored within 15 minutes, entry into the emergency classification level at no lower than a Site Area Emergency, when the plant was initially at power, would be appropriate. This implies that precursors to loss of all AC power events should appropriately be included in the EAL structure.
2. For severe core damage events, uncertainties exist in phenomena important to accident progressions leading to containment failure. Because of these uncertainties, predicting containment integrity may be difficult in these conditions. This is why maintaining containment integrity alone following sequences leading to severe core damage may be an insufficient basis for not escalating to a General Emergency.
3. PRAs show that leading contributors to latent fatalities were containment bypass, large LOCA with early containment failure, Station Blackout longer than 6 hours (e.g., LOCA consequences of Station Blackout), and reactor coolant pump seal failure. This indicates that generic EAL methodology must be sufficiently rigorous to address these sequences in a timely fashion.

Another critical element of the analysis to arrive at these threshold (boundary) conditions is the time that the plant might stay in that condition before moving to a higher emergency classification level. In particular, station blackout coping analyses performed in response to 10 CFR 50.63 and Regulatory Guide 1.155, "Station Blackout," may be used to determine whether a specific plant enters a Site Area Emergency or a General Emergency directly, and when escalation to General Emergency is indicated. The time dimension is critical to the EAL since the purpose of the emergency classification level for state and local officials is to notify them of the level of mobilization that may be necessary to handle the emergency. This is particularly true when a Site Area Emergency or General Emergency is IMMINENT. Establishing EALs for such conditions must take estimated evacuation time into consideration to minimize the potential for the plume to pass while evacuation is underway.

Regardless of whether or not containment integrity is challenged, it is possible for significant radioactive inventory within containment to result in EPA PAG plume exposure levels being exceeded even assuming containment is within technical specification allowable leakage rates. With or without containment challenge, however, a major release of radioactivity requiring off-site protection actions from core damage is not possible unless a major failure of fuel cladding allows radioactive material to be released from the core into the reactor coolant. NUREG-1228, "Source Estimations During Incident Response to Severe Nuclear Power Plant Accidents," indicates that such conditions do not exist when the amount of clad damage is less than 20%.

3.9 Emergency Action Levels

Planned evolutions involve preplanning to address the limitations imposed by the condition, the performance of required surveillance testing, and the implementation of specific controls prior to knowingly entering the condition in accordance with the specific requirements of the site's Technical Specifications. Activities which cause the site to operate beyond that allowed by the site's Technical Specifications, planned or unplanned, may result in an EAL threshold being met or exceeded. Planned evolutions to test, manipulate, repair, perform maintenance or modifications to systems and equipment that result in an EAL value being met or exceeded are not subject to classification and activation requirements as long as the evolution proceeds as planned and is within the operational limitations imposed by the specific operating license. However, these conditions may be subject to the reporting requirements of 10 CFR 50.72.

Classifications are based on evaluation of each Unit. All classifications are to be based upon valid indications, reports or conditions. Indications, reports or conditions are considered valid when they are verified by (1) an instrument channel check, or (2) indications on related or redundant indications, or (3) by direct observation by plant personnel, such that doubt related to the indication's operability, the condition's existence, or the report's accuracy is removed. Implicit in this definition is the need for timely assessment.

With the emergency classification levels defined, the thresholds that must be met for each EAL to be placed under the emergency classification level can be determined. There are two basic approaches to determining these EALs. EALs and emergency classification level boundaries coincide for those continuously measurable, instrumented ICs, such as radioactivity, core temperature, coolant levels, etc. For these ICs, the EAL will be the threshold reading that most closely corresponds to the emergency classification level description using the best available information.

For discrete (discontinuous) events, the approach will have to be somewhat different. Typically, in this category are internal and external hazards such as FIRE or earthquake. The purpose for including hazards in EALs is to assure that station personnel and off-site emergency response organizations are prepared to deal with consequential damage these hazards may cause. If, indeed, hazards have caused damage to safety functions or fission product barriers, this should be confirmed by symptoms or by observation of such failures. Therefore, it may be appropriate to enter an Alert status for events approaching or exceeding design basis limits such as Operating Basis Earthquake (OBE), design basis wind loads, FIRE within VITAL AREAS, etc. This would give the operating staff additional support and improved ability to determine the extent of plant damage. If damage to barriers or challenges to Critical Safety Functions (CSFs) have occurred or are identified, then the additional support can be used to escalate or terminate the emergency classification level based on what has been found. Of course, security events must reflect potential for increasing security threat levels.

Plant emergency operating procedures (EOPs) are designed to maintain and/or restore a set of CSFs which are listed in the order of priority for restoration efforts during accident conditions. While the actual nomenclature of the CSFs may vary among plants, generally the PWR CSF set includes:

- Subcriticality
- Core cooling
- Heat sink
- Pressure-temperature-stress (RCS integrity)
- Containment

- RCS inventory

There are diverse and redundant plant systems to support each CSF. By monitoring the CSFs instead of the individual system component status, the impact of multiple events is inherently addressed, e.g., the number of operable components available to maintain the critical safety function.

The EOPs contain detailed instructions regarding the monitoring of these functions and provides a scheme for classifying the significance of the challenge to the functions. In providing EALs based on these schemes, the emergency classification level can flow from the EOP assessment rather than being based on a separate EAL assessment. This is desirable as it reduces ambiguity and the time necessary to classify the event.

As an example, consider that the Westinghouse Owner's Group (WOG) Emergency Response Guidelines (ERGs) classify challenges as YELLOW, ORANGE, and RED paths. If the core exit thermocouples exceed 1200 degrees F or 700 degrees F with low reactor vessel water level, a RED path condition exists. The ERG considers a RED path as "... an extreme challenge to a plant function necessary for the protection of the public ..." This is almost identical to the present NRC NUREG-0654 description of a site area emergency, "... actual or likely failures of plant functions needed for the protection of the public ..." It reasonably follows that if any CSF enters a RED path, a Site Area Emergency exists. A general emergency could be considered to exist if core cooling CSF is in a RED path and the EOP function restoration procedures have not been successful in restoring core cooling.

Although the majority of the EALs provide very specific thresholds, the Emergency Director must remain alert to events or conditions that lead to the conclusion that exceeding the EAL is IMMINENT. If, in the judgment of the Emergency Director, an IMMINENT situation is at hand, the classification should be made as if the threshold has been exceeded. While this is particularly prudent at the higher emergency classification levels (as the early classification may provide for more effective implementation of protective measures), it is nonetheless applicable to all emergency classification levels.

3.10 Treatment of Multiple Events and Classification Level Upgrading

The above discussion deals primarily with simpler emergencies and events that may not escalate rapidly. However, usable EAL guidance must also consider rapidly evolving and complex events. Hence, emergency classification level upgrading and consideration of multiple events must be addressed.

When multiple simultaneous events occur, the emergency classification level is based on the highest EAL reached. For example, two Alerts remain in the Alert category. Or, an Alert and a Site Area Emergency is a Site Area Emergency. Further guidance is provided in RIS 2007-02, Clarification of NRC Guidance for Emergency Notifications During Quickly Changing Events.

Emergency classification level upgrading for multi-unit stations with shared safety-related systems and functions must also consider the effects of a loss of a common system on more than one unit (e.g. potential for radioactive release from more than one core at the same site). For example, many two-unit stations have their control panels for both units in close proximity within the same room. Thus, control room evacuation most likely would affect both units. There are a number of other systems and functions which may be shared at a given multi-unit station. This must be considered in the emergency classification level declaration and in the development of appropriate site specific ICs and EALs based on the generic EAL guidance.

Although the majority of the EALs provide very specific thresholds, the Emergency Director must remain alert to events or conditions that lead to the conclusion that exceeding the EAL is IMMEDIATE. If, in the judgment of the Emergency Director, an IMMEDIATE situation is at hand, the classification should be made as if the threshold has been exceeded. While this is particularly prudent at the higher emergency classification levels (as the early classification may provide for more effective implementation of protective measures), it is nonetheless applicable to all emergency classification levels.

3.11 Emergency Classification Level Downgrading

Another important aspect of usable EAL guidance is the consideration of what to do when the risk posed by an emergency is clearly decreasing. A combination approach involving recovery from General Emergency's and some Site Area Emergency's and termination from NOUEs, Alerts, and certain Site Area Emergency's causing no long term plant damage appears to be the best choice. Downgrading to lower emergency classification levels adds notifications but may have merit under certain circumstances.

3.12 Classifying Transient Events

For some events, the condition may be corrected before a declaration has been made. The key consideration in this situation is to determine whether or not further plant damage occurred while the corrective actions were being taken. In some situations, this can be readily determined, in other situations, further analyses (e.g., coolant radiochemistry sampling, may be necessary). Classify the event as indicated and terminate the emergency once assessment shows that there were no consequences from the event and other termination criteria are met.

Existing guidance for classifying transient events addresses the period of time of event recognition and classification (15 minutes). However, in cases when EAL declaration criteria may be met momentarily during the normal expected response of the plant, declaration requirements should not be considered to be met when the conditions are a part of the designed plant response, or result from appropriate Operator actions.

There may be cases in which a plant condition that exceeded an EAL was not recognized at the time of occurrence but is identified well after the condition has occurred (e.g., as a result of routine log or record review), and the condition no longer exists. In these cases, an emergency should not be declared.

Reporting requirements of 10 CFR 50.72 are applicable and the guidance of NUREG-1022, Event Reporting Guidelines 10 CFR 50.72 and 50.73, should be applied.

3.13 Operating Mode Applicability

The plant operating mode that existed at the time that the event occurred, prior to any protective system or operator action initiated in response to the condition, is compared to the mode applicability of the EALs. If an event occurs, and a lower or higher plant operating mode is reached before the emergency classification level can be declared, the emergency classification level shall be based on the mode that existed at the time the event occurred.

For events that occur in Cold Shutdown or Refueling, escalation is via EALs that have Cold Shutdown or Refueling for mode applicability, even if Hot Shutdown (or a higher mode) is entered during any subsequent heat-up. In particular, the fission product barrier EALs are applicable only to events that initiate in Hot Shutdown or higher.

MODE APPLICABILITY MATRIX

Mode	Recognition Category						
	A	C	D	E	F	H	S
Operating	X				X	X	X
Startup	X				X	X	X
Hot Standby	X				X	X	X
Hot Shutdown	X				X	X	X
Cold Shutdown	X	X				X	
Refueling	X	X				X	
Defueled	X	X				X	
None			X	X			

3.14 BWR Operating Modes (Follow site specific Technical Specifications)

Power Operations (1):	Mode Switch in Run
Startup (2):	Mode Switch in Startup/Hot Standby or Refuel (with all vessel head bolts fully tensioned)
Hot Shutdown (3):	Mode Switch in Shutdown, Average Reactor Coolant Temperature >200 °F
Cold Shutdown (4):	Mode Switch in Shutdown, Average Reactor Coolant Temperature ≤ 200 °F
Refueling (5):	Mode Switch in Shutdown or Refuel, and one or more vessel head bolts less than fully tensioned.
Defueled (None):	All reactor fuel removed from reactor pressure vessel. (Full core off load during refueling or extended outage).

3.15 PWR Operating Modes (Follow site specific Technical Specifications)

Power Operations (1):	Reactor Power > 5%, Keff ≥ 0.99
Startup (2):	Reactor Power ≤ 5%, Keff ≥ 0.99
Hot Standby (3):	RCS ≥ 350 °F, Keff < 0.99
Hot Shutdown (4):	200 °F < RCS < 350 °F, Keff < 0.99
Cold Shutdown (5):	RCS < 200 °F, Keff < 0.99
Refueling (6):	One or more vessel head closure bolts less than fully tensioned
Defueled (None):	All reactor fuel removed from reactor pressure vessel. (Full core off load during refueling or extended outage)

4.0 Human Factors Considerations

Some factors that should be considered in determining the method of presentation of EALs:

- Who is the audience (user) for this information? A senior utility executive would likely want information presented differently than a licensed operator. Off-site agencies and the NRC may have entirely different information needs.
- The conditions under which the information must be read, understood, and acted upon. Since the subject matter here is *emergency* actions, it is highly likely that the user of the EALs will be under high stress during the conditions where they are required to be used, particularly under conditions corresponding to Site Area Emergency and General Emergency.
- What is the user's perception as to the importance of the EALs compared to other actions and decisions that may be needed at the same time? To allow a licensed operator to discharge his responsibilities for dealing with the situation and also provide prompt notification to outside agencies, the classification and notification process must be rapid and concise.
- Is the EAL consistent with the user's knowledge of what constitutes an *emergency* situation?
- How much help does the user receive in deciding which EAL and emergency classification level is involved? An Emergency Director with a staffed TSC and EOF has many more resources immediately at his disposal than the licensed operator (typically, the Shift Supervisor) who has to make the initial decisions and take first actions.

Based on review of a number of plants' EALs and associated information, interviews with utility personnel, and a review of drill experience some recommendations follow:

4.1 Level of Integration of EALs with Plant Procedures

A rigorous integration of EALs and emergency classification level determinations into the plant procedure set, although having some benefits, is probably unnecessary. Such a rigorous integration could well make it more difficult to keep documentation up-to-date. However, keeping EALs totally separated from plant procedures and relying on licensed operator or other utility Emergency Director memory during infrequent, high stress periods is insufficient.

RECOMMENDATION: Use of visual cues in the plant procedures signaling that it is appropriate to consult the EALs is a method currently used by several utilities. This method can be effective when it is tied to appropriate training. Notes in the appropriate plant procedures to consult the EALs can also be used. It should be noted that this discussion is not restricted to only the emergency procedures; alarm recognition procedures, abnormal operating procedures, and normal operating procedures that apply to cold shutdown and refueling modes should also be included. In addition, EALs can be based on entry into particular procedures or existence of particular Critical Safety Function conditions.

4.2 Method of Presentation

A variety of presentation methods are presently in use, such as directly copying NUREG-0654 Appendix 1 language; adding plant specific indications to clarify NUREG-0654; using procedure language, including specific tag numbers for instrument readings and alarms; deliberately omitting instrument tag numbers; using flow charts, critical safety function status trees, checklists, and combinations of the above.

What is clear, however, is that the licensed operator (typically the Shift Supervisor) is the first user of this information, has the least amount of help in interpreting the EALs, and also has other significant responsibilities to fulfill while dealing with the EALs. Emergency Directors outside the control room to whom responsibilities are turned over have other resources and advisors available to them that a licensed operator may not have when first faced with an emergency situation. In addition, as an emergency situation evolves, the operating staff are the personnel who must first deal with information that is germane to changing the emergency classification level (up, down, or event termination).

RECOMMENDATION: The method of presentation should be one with which the operations staff are comfortable. As is the case for emergency procedures, bases for steps should be in separate (or separable) document suitable for training and for reference by emergency response personnel and off-site agencies. Each nuclear plant should already have presentation and human factors standards as part of its procedure writing guidance. EALs that are consistent with those procedure writing standards (in particular, emergency operating procedures which most closely correspond to the conditions under which EALs must be used) should be the norm for each utility.

Typically the presentation method often used in the industry is one in which the ICs, applicable operating modes, and example EALs are laid out on a large wall board and grouped by category, or sub-category. Usually two EAL boards are developed such that one board will have all applicable EALs for HOT operating modes and one board will have all applicable EALs for COLD operating modes. An EAL Basis Document is also developed. The EAL Basis Document will contain the same information and will also have relevant information included to support an understanding of the EAL and EAL methodology.

4.3 Symptom-Based, Event-Based, or Barrier-Based EALs

A review of the emergency classification level descriptions provided elsewhere in this document shows that NOUEs and Alerts deal primarily with sequences that are precursors to more serious emergencies or that may have taken a plant outside of its intended operating envelope, but currently poses no danger to the public. Observable indications in these classes can be events (e.g., natural phenomena), symptoms (e.g., high temperature, low water level), or barrier related (e.g., challenge to fission product barrier). As one escalates to Site Area Emergency and General Emergency, potential radiological impact to people (both on-site and off-site) increases. However, at this point the root cause event(s) leading to the emergency classification level escalation matter far less than the increased (potential for) radiological releases. Thus, EALs for these emergency classification levels should be primarily symptom and barrier based. It should be noted again, as stated in Section 3.4, that barrier monitoring is a subset of symptom monitoring, i.e., what readings (symptoms) indicate a challenge to a fission product barrier.

RECOMMENDATION: A combination approach that ranges from primarily event based EALs for NOUEs to primarily symptom or barrier based EALs for General Emergencies is recommended. This is to better assure that timely recognition and notification occurs, that events occurring during refueling and cold shutdown are appropriately addressed, and that multiple events can be effectively treated in the EALs.

5.0 Generic EAL Guidance

This section provides generic EAL guidance based on the information gathered and reviewed by the Task Force. Because of the wide variety of presentation methods used at different utilities, this document specifies guidance as to what each IC and EAL should address, and including sufficient basis information for each will best assure uniformity of approach. This approach is analogous to reactor vendors' owners groups developing generic emergency procedure guidelines that are converted by each utility into plant specific emergency operating procedures. Each utility is reminded, however, to review the "Human Factors Considerations" section of this document as part of implementation of the attached Generic EAL Guidance.

5.1 Generic Arrangement

The information is presented by Recognition Categories:

- A - Abnormal Rad Levels / Radiological Effluent
- C - Cold Shutdown / Refueling System Malfunction
- D - Permanently Defueled Station Malfunction
- E - Events Related to Independent Spent Fuel Storage Installations
- F - Fission Product Barrier Degradation
- H - Hazards and Other Conditions Affecting Plant Safety
- S - System Malfunction

The ICs for each of the above Recognition Categories A, C, D, E, H, and S are in the order of NOUE, Alert, Site Area Emergency, and General Emergency. For all Recognition Categories, an IC matrix versus emergency classification level is first shown. For Recognition Category F, the barrier-based EALs are presented in tables applicable for BWRs and for PWRs. The purpose of the IC matrices is to provide the reader with an overview of how the ICs are logically related under each emergency classification level.

Each of the EAL guides in Recognition Categories A, C, D, E, H, and S is structured in the following way:

- **Recognition Category** - As described above.
- **Emergency Classification Level** - NOUE, Alert, Site Area Emergency or General Emergency.
- **Initiating Condition** - Generic Identification and/or Title.

- **Operating Mode Applicability** - These modes are defined in each licensee's technical specifications. The mode classifications and terminology appropriate to the specific facility should be used.

Note that Permanently Defueled and ISFSI IC/EALs have no mode applicability.

NOTE: If an IC or EAL includes an explicit reference to a technical specification, and the technical specification is not applicable because of operating mode, then that particular IC or EAL is also not applicable. However, ensure adequate documentation is provided to justify not incorporating the IC/EAL. This documentation should provide sufficient detail to allow for an understanding of a licensee's Operating Modes and how/why the stated EAL is not applicable.

- **Example Emergency Action Level(s)** – these EALs are examples of conditions and indications that were considered to meet the criteria of the IC. These examples were not intended to be all encompassing, and some may not apply to a particular facility. Utilities should generally address each example EAL that applies to their site. If an example EAL does not apply because of its wording, e.g., specifies instrumentation not available at the site, the utility should identify other available means for entry into the IC. Ideally, the example EALs used will be unambiguous, expressed in site specific nomenclature, and be readily discernible from control room instrumentation.
- **Basis** – provides information that explains the IC and example EALs. The bases are also written to assist the personnel implementing the generic guidance into site specific procedures. Developer information in the bases provides information intended to assist with establishing site specific instrumentation values. Appendices A, D, and E provide detailed guidance on implementing their corresponding Recognition Categories.

For Recognition Category F, basis information is presented in a format consistent with Tables 3 and 4. The presentation method shown for Fission Product Barrier Function Table was chosen to clearly show the synergism among the EALs and to support more accurate dynamic assessments. Other acceptable methods of achieving these goals which are currently in use include flow charts, block diagrams, and checklist tables. Utilities selecting these alternatives need to ensure that all possible EAL combinations in the Fission Product Barrier Function Table are addressed in their presentation method.

5.2 Generic Bases

The generic guidance has the primary threshold for NOUEs as operation outside the safety envelope for the plant as defined by plant technical specifications, including LCOs and Action Statement Times. In addition, certain precursors of more serious events such as loss of off-site AC power and earthquakes are included in NOUE IC/EALs. This provides a clear demarcation between the lowest emergency classification level and "non-emergency" notifications specified by 10 CFR 50.72.

For a number of Alerts, IC/EALs are chosen based on hazards which may cause damage to plant safety functions (e.g., tornadoes, hurricanes, FIRE in VITAL AREAS) or require additional help directly (control room evacuation) and thus increased monitoring of the plant is warranted. The symptom-based and barrier-based IC/EALs are sufficiently anticipatory to address the results of multiple failures, regardless of whether there is or is not a common cause. Declaration of the Alert will already result in the staffing of the TSC for assistance and additional monitoring. Thus, direct escalation to the Site Area Emergency is unnecessary. Other Alerts, which have been specified, correspond to conditions that are consistent with the emergency classification level description.

The basis for declaring a Site Area Emergency and General Emergency is primarily the extent and severity of fission product barrier challenges, based on plant conditions as presently known or as can be reasonably projected.

With regard to the Hazards Recognition Category, the existence of a hazard that represents a potential degradation in the level of safety of the plant is the basis of NOUE classification. If the hazard results in VISIBLE DAMAGE to plant structures or equipment associated with safety systems, or if system performance is affected, the event may be escalated to an Alert. The reference to “duration” or to “damage” to safety systems is intended only to size the event. Consequential damage from such hazards, if observed, would be the basis for escalation to Site Area Emergency or General Emergency, by entry to System Malfunction or Fission Product Barrier IC/EALs.

Portions of the basis are specifically designated as information necessary for the development of the site specific thresholds of the EALs. These developer information sections are in *[brackets and italicized]*. The information contained in these portions consists of references, examples, instructions for calculations, etc. These portions of the basis and applicable appendices need not be included in the technical basis document supporting the EALs. In some cases, the information developed from the developer information may be appropriate to include in the technical basis document.

5.3 Site Specific Implementation

The guidance presented here is not intended to be applied to plants as-is. However, the benefits of aligning with the guidance as closely as possible may be realized in improved interface with the NRC and other utilities, and better positioning to adopt future enhancements such as FAQs. The guidance is intended to provide the logic for developing site specific IC/EALs using site specific IC/EAL presentation methods (formats). When plant design prevents use of ICs/EALs prescribed in the guidance document, other indications that address the subject condition should be implemented. RIS 2003-18 and its supplements 1 and 2 clarify the expectations for alignment with the guidance document and the associated regulatory review requirements.

The generic guidance includes ICs and example EALs. It is the intent of this guidance that both be included in the site specific implementation. Each serves a specific purpose. The IC is intended to be the fundamental criteria for the declaration, whereas, the EALs are intended to represent unambiguous examples of conditions that may meet the IC. There may be unforeseen events, or combinations of events, for which the EALs may not be exceeded, but in the judgment of the Emergency Director, the intent of the IC may be met. While the generic guidance does include Emergency Director judgment ICs, the additional detail in the individual ICs will facilitate classifications over the broad guidance of the ED judgment ICs.

For sites involving more than one reactor unit, consideration needs to be given to how events involving shared safety functions may affect more than one unit, and whether or not this may be a factor in escalating the event.

State and local requirements have not been reflected in the generic guidance and should be considered on a case-by-case basis with appropriate state and local emergency response organizations.

Utilities should prepare an EAL Basis Document including basis information with the IC/EALs. This information may assist the Emergency Director in making classifications, particularly those involving judgment or multiple events. The basis information may also be useful in training, for explaining event classifications to off-site officials, and would facilitate regulatory review and approval of the classification scheme.

5.4 Definitions

In the IC/EALs, selected words have been set in all capital letters. These words are defined terms having specific meanings as they relate to this procedure. Definitions of these terms are provided below.

AFFECTING SAFE SHUTDOWN: Event in progress has adversely affected functions that are necessary to bring the plant to and maintain it in the applicable HOT or COLD SHUTDOWN condition. Plant condition applicability is determined by Technical Specification LCOs in effect.

Example 1: Event causes damage that results in entry into an LCO that requires the plant to be placed in HOT SHUTDOWN. HOT SHUTDOWN is achievable, but COLD SHUTDOWN is not. This event is not "AFFECTING SAFE SHUTDOWN."

Example 2: Event causes damage that results in entry into an LCO that requires the plant to be placed in COLD SHUTDOWN. HOT SHUTDOWN is achievable, but COLD SHUTDOWN is not. This event is "AFFECTING SAFE SHUTDOWN."

BOMB: Refers to an explosive device suspected of having sufficient force to damage plant systems or structures.

CIVIL DISTURBANCE: A group of persons violently protesting station operations or activities at the site.

CONFINEMENT BOUNDARY: The barrier(s) between areas containing radioactive substances and the environment.

CONTAINMENT CLOSURE: The site specific procedurally defined actions taken to secure containment (primary or secondary for BWR) and its associated structures, systems, and components as a functional barrier to fission product release under existing plant conditions.

EXPLOSION: A rapid, violent, unconfined combustion, or catastrophic failure of pressurized/energized equipment that imparts energy of sufficient force to potentially damage permanent structures, systems, or components.

EXTORTION: An attempt to cause an action at the station by threat of force.

FAULTED: (PWRs) in a steam generator, the existence of secondary side leakage that results in an uncontrolled drop in steam generator pressure or the steam generator being completely depressurized.

FIRE: Combustion characterized by heat and light. Sources of smoke such as slipping drive belts or overheated electrical equipment do not constitute FIRES. Observation of flame is preferred but is NOT required if large quantities of smoke and heat are observed.

HOSTAGE: A person(s) held as leverage against the station to ensure that demands will be met by the station.

HOSTILE ACTION: An act toward a NPP or its personnel that includes the use of violent force to destroy equipment, take HOSTAGES, and/or intimidate the licensee to achieve an end. This includes attack by air, land, or water using guns, explosives, PROJECTILES, vehicles, or other devices used to deliver destructive force. Other acts that satisfy the overall intent may be included. HOSTILE ACTION should not be construed to include acts of civil disobedience or felonious acts that are not part of a concerted attack on the NPP. Non-terrorism-based EALs should be used to address such activities (i.e., this may include violent acts between individuals in the owner controlled area).

HOSTILE FORCE: One or more individuals who are engaged in a determined assault, overtly or by stealth and deception, equipped with suitable weapons capable of killing, maiming, or causing destruction.

IMMINENT: Mitigation actions have been ineffective, additional actions are not expected to be successful, and trended information indicates that the event or condition will occur. Where IMMINENT timeframes are specified, they shall apply.

INTRUSION: A person(s) present in a specified area without authorization. Discovery of a BOMB in a specified area is indication of INTRUSION into that area by a HOSTILE FORCE.

INDEPENDENT SPENT FUEL STORAGE INSTALLATION (ISFSI): A complex that is designed and constructed for the interim storage of spent nuclear fuel and other radioactive materials associated with spent fuel storage.

NORMAL PLANT OPERATIONS: Activities at the plant site associated with routine testing, maintenance, or equipment operations, in accordance with normal operating or administrative procedures. Entry into abnormal or emergency operating procedures, or deviation from normal security or radiological controls posture, is a departure from NORMAL PLANT OPERATIONS.

PROJECTILE: An object directed toward a NPP that could cause concern for its continued operability, reliability, or personnel safety.

PROTECTED AREA: Typically the site specific area which normally encompasses all controlled areas within the security PROTECTED AREA fence.

RUPTURED: (PWRs) in a steam generator, existence of primary-to-secondary leakage of a magnitude sufficient to require or cause a reactor trip and safety injection.

SABOTAGE: Deliberate damage, mis-alignment, or mis-operation of plant equipment with the intent to render the equipment inoperable. Equipment found tampered with or damaged due to malicious mischief may not meet the definition of SABOTAGE until this determination is made by security supervision.

SECURITY CONDITION: Any Security Event as listed in the approved security contingency plan that constitutes a threat/compromise to site security, threat/risk to site personnel, or a potential degradation to the level of safety of the plant. A SECURITY CONDITION does not involve a HOSTILE ACTION.

SIGNIFICANT TRANSIENT: An UNPLANNED event involving one or more of the following: (1) automatic turbine runback greater than 25% thermal reactor power, (2) electrical load rejection greater than 25% full electrical load, (3) Reactor Trip, (4) Safety Injection Activation, or (5) thermal power oscillations greater than 10%.

STRIKE ACTION: A work stoppage within the PROTECTED AREA by a body of workers to enforce compliance with demands made on (site specific). The STRIKE ACTION must threaten to interrupt NORMAL PLANT OPERATIONS.

UNISOLABLE: A breach or leak that cannot be promptly isolated.

UNPLANNED: A parameter change or an event that is not the result of an intended evolution and requires corrective or mitigative actions.

VALID: An indication, report, or condition, is considered to be VALID when it is verified by (1) an instrument channel check, (2) indications on related or redundant indicators, or (3) by direct observation by plant personnel, such that doubt related to the indicator's operability, the condition's existence, or the report's accuracy is removed. Implicit in this definition is the need for timely assessment.

VISIBLE DAMAGE: Damage to equipment or structure that is readily observable without measurements, testing, or analysis. Damage is sufficient to cause concern regarding the continued operability or reliability of the affected structure, system, or component. Example damage includes: deformation due to heat or impact, denting, penetration, rupture, cracking, and paint blistering. Surface blemishes (e.g., paint chipping, scratches) should not be included.

VITAL AREAS: Typically any site specific areas, normally within the PROTECTED AREA, that contains equipment, systems, components, or material, the failure, destruction, or release of which could directly or indirectly endanger the public health and safety by exposure to radiation.

5.5 ABNORMAL RAD LEVELS / RADIOLOGICAL EFFLUENT EALs

Table 5-A-1: Recognition Category “A” Initiating Condition Matrix

GENERAL EMERGENCY	SITE AREA EMERGENCY	ALERT	UNUSUAL EVENT
<p>AG1 Off-site dose resulting from an actual or IMMEDIATE release of gaseous radioactivity Greater Than 1000 mrem TEDE or 5000 mrem Thyroid CDE for the actual or projected duration of the release using actual meteorology. <i>Op. Modes: All</i></p>	<p>AS1 Off-site dose resulting from an actual or IMMEDIATE release of gaseous radioactivity Greater Than 100 mrem TEDE or 500 mrem Thyroid CDE for the actual or projected duration of the release. <i>Op. Modes: All</i></p>	<p>AA1 Any release of gaseous or liquid radioactivity to the environment Greater Than 200 times the Radiological Effluent Technical Specifications/ODCM for 15 minutes or longer. <i>Op. Modes: All</i></p>	<p>AU1 Any release of gaseous or liquid radioactivity to the environment Greater Than 2 times the Radiological Effluent Technical Specifications/ODCM for 60 minutes or longer. <i>Op. Modes: All</i></p>
		<p>AA3 Rise in radiation levels within the facility that impedes operation of systems required to maintain plant safety functions. <i>Op. Modes: All</i></p>	<p>AU2 UNPLANNED rise in plant radiation levels. <i>Op. Modes: All</i></p>
		<p>AA2 Damage to irradiated fuel or loss of water level that has resulted or will result in the uncovering of irradiated fuel outside the reactor vessel. <i>Op. Modes: All</i></p>	

ABNORMAL RAD LEVELS / RADIOLOGICAL EFFLUENT

AU1

Initiating Condition - NOTIFICATION OF UNUSUAL EVENT

Any release of gaseous or liquid radioactivity to the environment greater than 2 times the Radiological Effluent Technical Specifications/ODCM for 60 minutes or longer.

Operating Mode Applicability: All

Example Emergency Action Levels: (1 or 2 or 3 or 4 or 5)

Note: The Emergency Director should not wait until the applicable time has elapsed, but should declare the event as soon as it is determined that the release duration has exceeded, or will likely exceed, the applicable time. In the absence of data to the contrary, assume that the release duration has exceeded the applicable time if an ongoing release is detected and the release start time is unknown.

1. VALID reading on **ANY** of the following radiation monitors greater than the reading shown for 60 minutes or longer:

(site specific monitor list and threshold values)
2. VALID reading on any effluent monitor reading greater than 2 times the alarm setpoint established by a current radioactivity discharge permit for 60 minutes or longer.
3. Confirmed sample analyses for gaseous or liquid releases indicates concentrations or release rates greater than 2 times (site specific RETS values) for 60 minutes or longer.
4. VALID reading on perimeter radiation monitoring system reading greater than 0.10 mR/hr above normal* background for 60 minutes or longer. [for sites having telemetered perimeter monitors]
5. VALID indication on automatic real-time dose assessment capability indicating greater than (site specific value) for 60 minutes or longer. [for sites having such capability]

*Normal can be considered as the highest reading in the past twenty-four hours excluding the current peak value.

Basis:

[Refer to Appendix A for a detailed basis of the radiological effluent IC/EALs.]

The Emergency Director should not wait until the applicable time has elapsed, but should declare the event as soon as it is determined that the condition will likely exceed the applicable time.

This IC addresses a potential decrease in the level of safety of the plant as indicated by a radiological release that exceeds regulatory commitments for an extended period of time.

ABNORMAL RAD LEVELS / RADIOLOGICAL EFFLUENT

Nuclear power plants incorporate features intended to control the release of radioactive effluents to the environment. Further, there are administrative controls established to prevent unintentional releases, or control and monitor intentional releases. *[These controls are located in the Off-site Dose Calculation Manual (ODCM), and for plants that have not implemented Generic Letter 89-01, in the Radiological Effluent Technical Specifications (RETS).]* The occurrence of extended, uncontrolled radioactive releases to the environment is indicative of a degradation in these features and/or controls.

[Some sites may find it advantageous to address gaseous and liquid releases with separate EALs.]

The RETS multiples are specified in AU1 and AA1 only to distinguish between non-emergency conditions, and from each other. While these multiples obviously correspond to an off-site dose or dose rate, the emphasis in classifying these events is the degradation in the level of safety of the plant, not the magnitude of the associated dose or dose rate.

[Releases should not be prorated or averaged. For example, a release exceeding 4x ODCM for 30 minutes does not meet the threshold.]

This EAL includes any release for which a radioactivity discharge permit was not prepared, or a release that exceeds the conditions (e.g., minimum dilution flow, maximum discharge flow, alarm setpoints, etc.) on the applicable permit.

EAL #1

This EAL addresses radioactivity releases, that for whatever reason, cause effluent radiation monitor readings to exceed the threshold identified in the IC.

This EAL is intended for sites that have established effluent monitoring on non-routine release pathways for which a discharge permit would not normally be prepared.

[The ODCM establishes a methodology for determining effluent radiation monitor setpoints. The ODCM specifies default source terms and, for gaseous releases, prescribes the use of pre-determined annual average meteorology in the most limiting downwind sector for showing compliance with the regulatory commitments. This EAL should be determined using this methodology.]

EAL #2

This EAL addresses radioactivity releases, that for whatever reason, cause effluent radiation monitor readings to exceed the threshold identified in the IC established by the radioactivity discharge permit. This value may be associated with a planned batch release, or a continuous release path.

[In either case, the value is established by the ODCM to warn of a release that is not in compliance with the RETS. Indexing the EAL to the ODCM setpoints in this manner insures that the EAL will never be less than the setpoint established by a specific discharge permit.]

EAL #3

This EAL addresses uncontrolled releases that are detected by sample analyses, particularly on unmonitored pathways, e.g., spills of radioactive liquids into storm drains, heat exchanger leakage in river water systems, etc.

ABNORMAL RAD LEVELS / RADIOLOGICAL EFFLUENT

EALs #4 and #5

The 0.10 mR/hr value in EAL #4, and the site specific value for EAL #5, is based on a release rate not exceeding 500 mrem per year.

[As provided in the ODCM / RETS, prorated over 8766 hours, multiplied by two, and rounded. ($500 \div 8766 \times 2 = 0.114$).]

EAL #1 and #2 directly correlate with the IC since annual average meteorology is required to be used in showing compliance with the ODCM and is used in calculating the alarm setpoints. EALs #4 and #5 are a function of actual meteorology, which will likely be different from the limiting annual average value. Thus, there will likely be a numerical inconsistency.

The underlying basis of this EAL involves the degradation in the level of safety of the plant implied by the uncontrolled release. Exceeding EAL #4 or #5 is an indication of an uncontrolled release.

ABNORMAL RAD LEVELS / RADIOLOGICAL EFFLUENT

AU2

Initiating Condition - NOTIFICATION OF UNUSUAL EVENT

UNPLANNED rise in plant radiation levels.

Operating Mode Applicability: All

Example Emergency Action Levels: (1 or 2)

1. a. UNPLANNED water level drop in a reactor refueling pathway as indicated by (site specific level or indication).
AND
- b. VALID Area Radiation Monitor reading rise on (site specific list).
2. UNPLANNED VALID Area Radiation Monitor readings or survey results indicate a rise by a factor of 1000 over normal* levels.

*Normal can be considered as the highest reading in the past twenty-four hours excluding the current peak value.

Basis:

This IC addresses increased radiation levels as a result of water level decreases above irradiated fuel or events that have resulted, or may result, in UNPLANNED increases in radiation dose rates within plant buildings. These radiation increases represent a loss of control over radioactive material and represent a potential degradation in the level of safety of the plant.

EAL #1

[Site specific indications may include instrumentation such as water level and local area radiation monitors, and personnel (e.g., refueling crew) reports. If available, video cameras may allow remote observation. Depending on available level instrumentation, the declaration threshold may need to be based on indications of water makeup rate or decrease in water storage tank level.]

[In light of Reactor Cavity Seal failure incidents at two different PWRs and loss of water in the Spent Fuel Pit/Fuel Transfer Canal at a BWR, explicit coverage of these types of events via threshold #1 is appropriate given their potential for increased doses to plant staff.]

The refueling pathway is a site specific combination of cavities, tubes, canals and pools. While a radiation monitor could detect an increase in dose rate due to a drop in the water level, it might not be a reliable indication of whether or not the fuel is covered.

[For example, a refueling bridge ARM reading may increase due to planned evolutions such as head lift, or even a fuel assembly being raised in the manipulator mast. Also, a monitor could in fact be properly responding to a known event involving transfer or relocation of a source, stored in or near the fuel pool or responding to a planned evolution such as removal of the reactor head. Generally, increased radiation monitor indications will need to be combined with another indicator (or personnel report) of water loss.]

ABNORMAL RAD LEVELS / RADIOLOGICAL EFFLUENT

[Application of this EAL requires understanding of the actual radiological conditions present in the vicinity of the monitor. Information Notice No. 90-08, "KR-85 Hazards from Decayed Fuel" should be considered in establishing radiation monitor EALs.]

For refueling events where the water level drops below the RPV flange classification would be via CU2. This event escalates to an Alert per AA2 if irradiated fuel outside the reactor vessel is uncovered. For events involving irradiated fuel in the reactor vessel, escalation would be via the Fission Product Barrier Table for events in operating modes 1-4.

EAL #2

This EAL addresses increases in plant radiation levels that represent a loss of control of radioactive material resulting in a potential degradation in the level of safety of the plant.

This EAL excludes radiation level increases that result from planned activities such as use of radiographic sources and movement of radioactive waste materials. A specific list of ARMs is not required as it would restrict the applicability of the Threshold. The intent is to identify loss of control of radioactive material in any monitored area.

ABNORMAL RAD LEVELS / RADIOLOGICAL EFFLUENT

AA1

Initiating Condition - ALERT

Any release of gaseous or liquid radioactivity to the environment greater than 200 times the Radiological Effluent Technical Specifications/ODCM for 15 minutes or longer.

Operating Mode Applicability: All

Example Emergency Action Levels: (1 or 2 or 3 or 4 or 5)

Note: The Emergency Director should not wait until the applicable time has elapsed, but should declare the event as soon as it is determined that the release duration has exceeded, or will likely exceed, the applicable time. In the absence of data to the contrary, assume that the release duration has exceeded the applicable time if an ongoing release is detected and the release start time is unknown.

1. VALID reading on **ANY** of the following radiation monitors greater than the reading shown for 15 minutes or longer:

(site specific monitor list and threshold values)
2. VALID reading on any effluent monitor reading greater than 200 times the alarm setpoint established by a current radioactivity discharge permit for 15 minutes or longer.
3. Confirmed sample analyses for gaseous or liquid releases indicates concentrations or release rates greater than 200 times (site specific RETS values) for 15 minutes or longer.
4. VALID reading on perimeter radiation monitoring system reading greater than 10.0 mR/hr above normal* background for 15 minutes or longer. [for sites having telemetered perimeter monitors]
5. VALID indication on automatic real-time dose assessment capability indicating greater than (site specific value) for 15 minutes or longer. [for sites having such capability]

*Normal can be considered as the highest reading in the past twenty-four hours excluding the current peak value.

Basis:

[Refer to Appendix A for a detailed basis of the radiological effluent IC/EALs.]

The Emergency Director should not wait until the applicable time has elapsed, but should declare the event as soon as it is determined that the condition will likely exceed the applicable time.

This IC addresses an actual or substantial potential decrease in the level of safety of the plant as indicated by a radiological release that exceeds regulatory commitments for an extended period of time.

ABNORMAL RAD LEVELS / RADIOLOGICAL EFFLUENT

Nuclear power plants incorporate features intended to control the release of radioactive effluents to the environment. Further, there are administrative controls established to prevent unintentional releases, or control and monitor intentional releases. *[These controls are located in the Off-site Dose Calculation Manual (ODCM), and for plants that have not implemented Generic Letter 89-01, in the Radiological Effluent Technical Specifications (RETS).]* The occurrence of extended, uncontrolled radioactive releases to the environment is indicative of a degradation in these features and/or controls.

[Some sites may find it advantageous to address gaseous and liquid releases with separate EALs.]

The RETS multiples are specified in AU1 and AA1 only to distinguish between non-emergency conditions, and from each other. While these multiples obviously correspond to an off-site dose or dose rate, the emphasis in classifying these events is the degradation in the level of safety of the plant, not the magnitude of the associated dose or dose rate.

[To ensure a realistic near-linear escalation path, a value should be selected roughly half-way between the AU1 value and the value calculated for AS1 value. The value will be based on radiation monitor readings to exceed 200 times the Technical Specification limit and releases are not terminated within 15 minutes. The ODCM establishes a methodology for determining effluent radiation monitor setpoints. The ODCM specifies default source terms and, for gaseous releases, prescribes the use of pre-determined annual average meteorology in the most limiting downwind sector for showing compliance with the regulatory commitments. This EAL can be determined using this methodology if appropriate.]

[Releases should not be prorated or averaged. For example, a release exceeding 600x ODCM for 5 minutes does not meet the threshold.]

This EAL includes any release for which a radioactivity discharge permit was not prepared, or a release that exceeds the conditions (e.g., minimum dilution flow, maximum discharge flow, alarm setpoints, etc.) on the applicable permit.

EAL #1

This EAL is intended for sites that have established effluent monitoring on non-routine release pathways for which a discharge permit would not normally be prepared.

EAL #2

This EAL addresses radioactivity releases, that for whatever reason, cause effluent radiation monitor readings to exceed the threshold identified in the IC established by the radioactivity discharge permit. This value may be associated with a planned batch release, or a continuous release path.

[In either case, the value is established by the ODCM to warn of a release that is not in compliance with the RETS. Indexing the EAL to the ODCM setpoints in this manner insures that the EAL will never be less than the setpoint established by a specific discharge permit.]

EAL #3

This EAL addresses uncontrolled releases that are detected by sample analyses, particularly on unmonitored pathways, e.g., spills of radioactive liquids into storm drains, heat exchanger leakage in river water systems, etc.

ABNORMAL RAD LEVELS / RADIOLOGICAL EFFLUENT

EALs #4 and #5

The 10.0 mR/hr value in EAL #4 , and the site specific value for EAL #5, is based on a release rate not exceeding 500 mrem per year.

[As provided in the ODCM / RETS, prorated over 8766 hours, multiplied by 200, and rounded. ($500 \div 8766 \times 200 = 11.4$)].

EAL #1 and #2 directly correlate with the IC since annual average meteorology is required to be used in showing compliance with the ODCM and is used in calculating the alarm setpoints. EALs #4 and #5 are a function of actual meteorology, which will likely be different from the limiting annual average value. Thus, there will likely be a numerical inconsistency.

The underlying basis of this EAL involves the degradation in the level of safety of the plant implied by the uncontrolled release. Exceeding EAL #4 or #5 is an indication of an uncontrolled release.

ABNORMAL RAD LEVELS / RADIOLOGICAL EFFLUENT

AA2

Initiating Condition - ALERT

Damage to irradiated fuel or loss of water level that has resulted or will result in the uncovering of irradiated fuel outside the reactor vessel.

Operating Mode Applicability: All

Example Emergency Action Levels: (1 or 2)

1. A water level drop in the reactor refueling cavity, spent fuel pool or fuel transfer canal that will result in irradiated fuel becoming uncovered.
2. A VALID alarm or (site specific elevated reading) on **ANY** of the following due to damage to irradiated fuel or loss of water level.

(site specific radiation monitors)

Basis:

This IC addresses increases in radiation dose rates within plant buildings, and may be a precursor to a radioactivity release to the environment. These events represent a loss of control over radioactive material and represent an actual or substantial potential degradation in the level of safety of the plant.

[These events escalate from AU2 in that fuel activity has been released, or is anticipated due to fuel heatup. This IC applies to spent fuel requiring water coverage and is not intended to address spent fuel which is licensed for dry storage.]

EAL #1

[Site specific indications may include instrumentation such as water level and local area radiation monitors, and personnel (e.g., refueling crew) reports. If available, video cameras may allow remote observation. Depending on available level instrumentation, the declaration threshold may need to be based on indications of water makeup rate or decrease in water storage tank level.]

[In light of Reactor Cavity Seal failure incidents at two different PWRs and loss of water in the Spent Fuel Pit/Fuel Transfer Canal at a BWR, explicit coverage of these types of events via threshold #1 is appropriate given their potential for increased doses to plant staff.]

EAL #2

This EAL addresses radiation monitor indications of fuel uncovering and/or fuel damage.

Increased ventilation monitor readings may be indication of a radioactivity release from the fuel, confirming that damage has occurred. Increased background at the ventilation monitor due to water level decrease may mask increased ventilation exhaust airborne activity and needs to be considered.

ABNORMAL RAD LEVELS / RADIOLOGICAL EFFLUENT

While a radiation monitor could detect an increase in dose rate due to a drop in the water level, it might not be a reliable indication of whether or not the fuel is covered.

[For example, a refueling bridge ARM reading may increase due to planned evolutions such as head lift, or even a fuel assembly being raised in the manipulator mast. Also, a monitor could in fact be properly responding to a known event involving transfer or relocation of a source, stored in or near the fuel pool or responding to a planned evolution such as removal of the reactor head. Generally, increased radiation monitor indications will need to be combined with another indicator (or personnel report) of water loss.]

[Application of this EAL requires understanding of the actual radiological conditions present in the vicinity of the monitor. Information Notice No. 90-08, "KR-85 Hazards from Decayed Fuel" should be considered in establishing radiation monitor EALs.]

Escalation of this emergency classification level, if appropriate, would be based on AS1 or AG1.

ABNORMAL RAD LEVELS / RADIOLOGICAL EFFLUENT

AA3

Initiating Condition - ALERT

Rise in radiation levels within the facility that impedes operation of systems required to maintain plant safety functions.

Operating Mode Applicability: All

Example Emergency Action Levels: (1 or 2)

Dose rate greater than 15 mR/hr in **ANY** of the following areas requiring continuous occupancy to maintain plant safety functions:

(site specific area list)

Basis:

This IC addresses increased radiation levels that: impact continued operation in areas requiring continuous occupancy to maintain safe operation or to perform a safe shutdown.

The cause and/or magnitude of the increase in radiation levels is not a concern of this IC. The Emergency Director must consider the source or cause of the increased radiation levels and determine if any other IC may be involved.

[At multiple-unit sites, the EALs could result in declaration of an Alert at one unit due to a radioactivity release or radiation shine resulting from a major accident at the other unit. This is appropriate if the increase impairs operations at the operating unit.]

[This IC is not meant to apply to increases in the containment dome radiation monitors as these are events which are addressed in the fission product barrier table.]

[The value of 15mR/hr is derived from the GDC 19 value of 5 rem in 30 days with adjustment for expected occupancy times. Although Section III.D.3 of NUREG-0737, "Clarification of TMI Action Plan Requirements", provides that the 15 mR/hr value can be averaged over the 30 days, the value is used here without averaging, as a 30 day duration implies an event potentially more significant than an Alert.]

Areas requiring continuous occupancy include the control room and, as appropriate to the site, any other control stations that are staffed continuously, such as a radwaste control room, or a security alarm station. *[Typically these areas are the Control Room and the Central Alarm Station (CAS).]*

ABNORMAL RAD LEVELS / RADIOLOGICAL EFFLUENT

AS1

Initiating Condition -- SITE AREA EMERGENCY

Off-site dose resulting from an actual or IMMINENT release of gaseous radioactivity greater than 100 mrem TEDE or 500 mrem Thyroid CDE for the actual or projected duration of the release.

Operating Mode Applicability: All

Example Emergency Action Levels: (1 or 2 or 3 or 4)

Note: The Emergency Director should not wait until the applicable time has elapsed, but should declare the event as soon as it is determined that the condition will likely exceed the applicable time. If dose assessment results are available, declaration should be based on dose assessment instead of radiation monitor values. Do not delay declaration awaiting dose assessment results.

1. VALID reading on **ANY** of the following radiation monitors greater than the reading shown for 15 minutes or longer:

(site specific monitor list and threshold values)
2. Dose assessment using actual meteorology indicates doses greater than 100 mrem TEDE or 500 mrem thyroid CDE at or beyond the site boundary.
3. VALID perimeter radiation monitoring system reading greater than 100 mR/hr for 15 minutes or longer. [for sites having telemetered perimeter monitors]
4. Field survey results indicate closed window dose rates greater than 100 mR/hr expected to continue for 60 minutes or longer; or analyses of field survey samples indicate thyroid CDE greater than 500 mrem for one hour of inhalation, at or beyond the site boundary.

Basis:

[Refer to Appendix A for a detailed basis of the radiological effluent IC/EALs.]

This IC addresses radioactivity releases that result in doses at or beyond the site boundary that exceed 10% of the EPA Protective Action Guides (PAGs). Releases of this magnitude are associated with the failure of plant systems needed for the protection of the public.

[While these failures are addressed by other ICs, this IC provides appropriate diversity and addresses events which may not be able to be classified on the basis of plant status alone. It is important to note that for the more severe accidents the release may be unmonitored or there may be large uncertainties associated with the source term and/or meteorology.]

[The EPA PAGs are expressed in terms of the sum of the effective dose equivalent (EDE) and the committed effective dose equivalent (CEDE), or as the thyroid committed dose equivalent (CDE). For the purpose of these IC/EALs, the dose quantity total effective dose equivalent (TEDE), as defined in 10 CFR 20, is used in lieu of "...sum of EDE and CEDE..." The EPA PAG guidance provides for the use adult thyroid dose conversion factors. However, some states

ABNORMAL RAD LEVELS / RADIOLOGICAL EFFLUENT

have decided to calculate child thyroid CDE. Utility IC/EALs need to be consistent with those of the states involved in the facility's emergency planning zone.]

[The TEDE dose is set at 10% of the EPA PAG, while the 500 mrem thyroid CDE was established in consideration of the 1:5 ratio of the EPA PAG for TEDE and thyroid CDE.]

EAL #1

The site specific monitor list in EAL #1 should include effluent monitors on all potential release pathways.

[The monitor reading EALs should be determined using a dose assessment method that back calculates from the dose values specified in the IC. Since doses are generally not monitored in real-time, it is suggested that a release duration of one hour be assumed, and that the EALs be based on a site specific boundary (or beyond) dose of 100 mrem whole body or 500 mrem thyroid in one hour, whichever is more limiting (as was done for EALs #2 and #4). If individual site analyses indicate a longer or shorter duration for the period in which the substantial portion of the activity is released, the longer duration should be used.]

[The meteorology used should be the same as those used for determining AU1 and AA1 monitor reading EALs. The same source term (noble gases, particulates, and halogens) may also be used as long as it maintains a realistic and near linear escalation between the EALs for the four classifications. If proper escalations do not result from the use of the same source term, if the calculated values are unrealistically high, or if correlation between the values and dose assessment values does not exist, then consider using an accident source term for AS1 and AG1 calculations.]

Since dose assessment is based on actual meteorology, whereas the monitor reading EAL is not, the results from these assessments may indicate that the classification is not warranted, or may indicate that a higher classification is warranted. For this reason, emergency implementing procedures should call for the timely performance of dose assessments using actual meteorology and release information. If the results of these dose assessments are available when the classification is made (e.g., initiated at a lower classification level), the dose assessment results override the monitor reading EAL.

ABNORMAL RAD LEVELS / RADIOLOGICAL EFFLUENT

AG1

Initiating Condition -- GENERAL EMERGENCY

Off-site dose resulting from an actual or IMMINENT release of gaseous radioactivity greater than 1000 mrem TEDE or 5000 mrem Thyroid CDE for the actual or projected duration of the release using actual meteorology.

Operating Mode Applicability: All

Example Emergency Action Levels: (1 or 2 or 3 or 4)

Note: The Emergency Director should not wait until the applicable time has elapsed, but should declare the event as soon as it is determined that the condition will likely exceed the applicable time. If dose assessment results are available, declaration should be based on dose assessment instead of radiation monitor values. Do not delay declaration awaiting dose assessment results.

1. VALID reading on **ANY** of the following radiation monitors greater than the reading shown for 15 minutes or longer:

(site specific monitor list and threshold values)
2. Dose assessment using actual meteorology indicates doses greater than 1000 mrem TEDE or 5000 mrem thyroid CDE at or beyond the site boundary.
3. VALID perimeter radiation monitoring system reading greater than 1000 mR/hr for 15 minutes or longer. [for sites having telemetered perimeter monitors]
4. Field survey results indicate closed window dose rates greater than 1000 mR/hr expected to continue for 60 minutes or longer; or analyses of field survey samples indicate thyroid CDE greater than 5000 mrem for one hour of inhalation, at or beyond site boundary.

Basis:

[Refer to Appendix A for a detailed basis of the radiological effluent IC/EALs.]

This IC addresses radioactivity releases that result in doses at or beyond the site boundary that exceed the EPA Protective Action Guides (PAGs). Public protective actions will be necessary. Releases of this magnitude are associated with the failure of plant systems needed for the protection of the public and likely involve fuel damage.

[While these failures are addressed by other ICs, this IC provides appropriate diversity and addresses events which may not be able to be classified on the basis of plant status alone. It is important to note that for the more severe accidents the release may be unmonitored or there may be large uncertainties associated with the source term and/or meteorology.]

[The EPA PAGs are expressed in terms of the sum of the effective dose equivalent (EDE) and the committed effective dose equivalent (CEDE), or as the thyroid committed dose equivalent

ABNORMAL RAD LEVELS / RADIOLOGICAL EFFLUENT

(CDE). For the purpose of these IC/EALs, the dose quantity total effective dose equivalent (TEDE), as defined in 10 CFR 20, is used in lieu of "...sum of EDE and CEDE..." The EPA PAG guidance provides for the use adult thyroid dose conversion factors. However, some states have decided to calculate child thyroid CDE. Utility IC/EALs need to be consistent with those of the states involved in the facilities emergency planning zone.]

[The TEDE dose is set at the EPA PAG, while the 5000 mrem thyroid CDE was established in consideration of the 1:5 ratio of the EPA PAG for TEDE and thyroid CDE.]

EAL #1

The site specific monitor list in EAL #1 should include effluent monitors on all potential release pathways.

[The monitor reading EALs should be determined using a dose assessment method that back calculates from the dose values specified in the IC. Since doses are generally not monitored in real-time, it is suggested that a release duration of one hour be assumed, and that the EALs be based on a site specific boundary (or beyond) dose of 1000 mrem whole body or 5000 mrem thyroid in one hour, whichever is more limiting (as was done for EALs #2 and #4). If individual site analyses indicate a longer or shorter duration for the period in which the substantial portion of the activity is released, the longer duration should be used.]

[The meteorology used should be the same as those used for determining AU1 and AA1 monitor reading EALs. The same source term (noble gases, particulates, and halogens) may also be used as long as it maintains a realistic and near linear escalation between the EALs for the four classifications. If proper escalations do not result from the use of the same source term, if the calculated values are unrealistically high, or if correlation between the values and dose assessment values does not exist, then consider using an accident source term for AS1 and AG1 calculations.]

Since dose assessment is based on actual meteorology, whereas the monitor reading EAL is not, the results from these assessments may indicate that the classification is not warranted, or may indicate that a higher classification is warranted. For this reason, emergency implementing procedures should call for the timely performance of dose assessments using actual meteorology and release information. If the results of these dose assessments are available when the classification is made (e.g., initiated at a lower classification level), the dose assessment results override the monitor reading EAL.

5.6 COLD SHUTDOWN / REFUELING SYSTEM MALFUNCTION EALs

Table 5-C-1: Recognition Category “C” Initiating Condition Matrix

GENERAL EMERGENCY	SITE AREA EMERGENCY	ALERT	UNUSUAL EVENT
CG1 Loss of RCS/RPV inventory affecting fuel clad integrity with containment challenged. <i>Op. Modes: Cold Shutdown, Refueling</i>	CS1 Loss of RCS/RPV inventory affecting core decay heat removal capability. <i>Op. Modes: Cold Shutdown, Refueling</i>	CA1 Loss of RCS/RPV inventory. <i>Op. Modes: Cold Shutdown, Refueling</i>	CU1 RCS leakage. <i>Op. Modes: Cold Shutdown</i>
		CA3 Loss of all Off-site and all On-site AC power to emergency busses for 15 minutes or longer. <i>Op. Modes: Cold Shutdown, Refueling, Defueled</i>	CU2 UNPLANNED loss of RCS/RPV inventory. <i>Op. Modes: Refueling</i>
		CA4 Inability to maintain plant in cold shutdown. <i>Op. Modes: Cold Shutdown, Refueling</i>	CU3 AC power capability to emergency busses reduced to a single power source for 15 minutes or longer such that any additional single failure would result in station blackout. <i>Op. Modes: Cold Shutdown, Refueling</i>
			CU4 UNPLANNED loss of decay heat removal capability. <i>Op. Modes: Cold Shutdown, Refueling</i>
			CU6 Loss of all On-site or Off-site communications capabilities. <i>Op. Modes: Cold Shutdown, Refueling, Defueled</i>
			CU7 UNPLANNED loss of required DC power for 15 minutes or longer. <i>Op. Modes: Cold Shutdown, Refueling</i>
			CU8 Inadvertent criticality. <i>Op. Modes: Cold Shutdown, Refueling</i>

COLD SHUTDOWN / REFUELING SYSTEM MALFUNCTION

CU1

Initiating Condition -- NOTIFICATION OF UNUSUAL EVENT

RCS leakage.

Operating Mode Applicability: Cold Shutdown

Example Emergency Action Levels:

Note: The Emergency Director should not wait until the applicable time has elapsed, but should declare the event as soon as it is determined that the condition will likely exceed the applicable time.

1. RCS leakage results in the inability to maintain or restore RPV level greater than (site specific low level RPS actuation setpoint) for 15 minutes or longer. [*BWR*]
1. RCS leakage results in the inability to maintain or restore level within (site specific pressurizer or RCS/RPV level target band) for 15 minutes or longer. [*PWR*]

Basis:

This IC is considered to be a potential degradation of the level of safety of the plant. The inability to maintain or restore level is indicative of loss of RCS inventory.

Relief valve normal operation should be excluded from this IC. However, a relief valve that operates and fails to close per design should be considered applicable to this IC if the relief valve cannot be isolated.

Prolonged loss of RCS Inventory may result in escalation to the Alert emergency classification level via either CA1 or CA4.

[The difference between CU1 and CU2 deals with the RCS conditions that exist between cold shutdown and refueling modes. In the refueling mode the RCS is not intact and RPV level and inventory are monitored by different means. In cold shutdown the RCS will normally be intact and standard RCS inventory and level monitoring means are available.]

COLD SHUTDOWN / REFUELING SYSTEM MALFUNCTION

CU2

Initiating Condition -- NOTIFICATION OF UNUSUAL EVENT

UNPLANNED loss of RCS/RPV inventory.

Operating Mode Applicability: Refueling

Example Emergency Action Levels: (1 or 2)

Note: The Emergency Director should not wait until the applicable time has elapsed, but should declare the event as soon as it is determined that the condition will likely exceed the applicable time.

1. UNPLANNED RCS/RPV level drop as indicated by either of the following:
 - RCS/RPV water level drop below the RPV flange for 15 minutes or longer when the RCS/RPV level band is established above the RPV flange.
 - RCS/RPV water level drop below the RCS level band for 15 minutes or longer when the RCS/RPV level band is established below the RPV flange.
2. RCS/RPV level cannot be monitored with a loss of RCS/RPV inventory as indicated by an unexplained level rise in (site specific sump or tank).

Basis:

This IC is a precursor of more serious conditions and considered to be a potential degradation of the level of safety of the plant.

Refueling evolutions that decrease RCS water level below the RPV flange are carefully planned and procedurally controlled. An UNPLANNED event that results in water level decreasing below the RPV flange, or below the planned RCS water level for the given evolution (if the planned RCS water level is already below the RPV flange), warrants declaration of a NOUE due to the reduced RCS inventory that is available to keep the core covered.

The allowance of 15 minutes was chosen because it is reasonable to assume that level can be restored within this time frame using one or more of the redundant means of refill that should be available. If level cannot be restored in this time frame then it may indicate a more serious condition exists.

Continued loss of RCS Inventory will result in escalation to the Alert emergency classification level via either CA1 or CA4.

[The difference between CU1 and CU2 deals with the RCS conditions that exist between cold shutdown and refueling modes. In cold shutdown the RCS will normally be intact and standard RCS inventory and level monitoring means are available. In the refueling mode the RCS is not intact and RPV level and inventory are monitored by different means].

EAL #1

COLD SHUTDOWN / REFUELING SYSTEM MALFUNCTION

This EAL involves a decrease in RCS level below the top of the RPV flange that continues for 15 minutes due to an UNPLANNED event. This EAL is not applicable to decreases in flooded reactor cavity level, which is addressed by AU2 EAL1, until such time as the level decreases to the level of the vessel flange.

[For BWRs] if RPV level continues to decrease and reaches the Low-Low ECCS Actuation Setpoint then escalation to CA1 would be appropriate.

[For PWRs] If RPV level continues to decrease and reaches the Bottom ID of the RCS Loop then escalation to CA1 would be appropriate.

EAL #2

This EAL addresses conditions in the refueling mode when normal means of core temperature indication and RCS level indication may not be available. Redundant means of RPV level indication will normally be installed (including the ability to monitor level visually) to assure that the ability to monitor level will not be interrupted. However, if all level indication were to be lost during a loss of RCS inventory event, the operators would need to determine that RPV inventory loss was occurring by observing sump and tank level changes. Sump and tank level increases must be evaluated against other potential sources of leakage such as cooling water sources inside the containment to ensure they are indicative of RCS leakage.

Escalation to the Alert emergency classification level would be via either CA1 or CA4.

COLD SHUTDOWN / REFUELING SYSTEM MALFUNCTION

CU3

Initiating Condition -- NOTIFICATION OF UNUSUAL EVENT

AC power capability to emergency busses reduced to a single power source for 15 minutes or longer such that any additional single failure would result in station blackout.

Operating Mode Applicability: Cold Shutdown, Refueling

Example Emergency Action Level:

Note: The Emergency Director should not wait until the applicable time has elapsed, but should declare the event as soon as it is determined that the condition will likely exceed the applicable time.

1. a. AC power capability to (site specific emergency busses) reduced to a single power source for 15 minutes or longer.

AND

- b. Any additional single power source failure will result in station blackout.

Basis:

The condition indicated by this IC is the degradation of the off-site and on-site AC power systems such that any additional single failure would result in a station blackout. This condition could occur due to a loss of off-site power with a concurrent failure of all but one emergency generator to supply power to its emergency busses. The subsequent loss of this single power source would escalate the event to an Alert in accordance with CA3.

Fifteen minutes was selected as a threshold to exclude transient or momentary losses of power.

[At multi-unit stations, the EALs should allow credit for operation of installed design features, such as cross-ties or swing diesels, provided that abnormal or emergency operating procedures address their use. However, these stations must also consider the impact of this condition on other shared safety functions in developing the site specific EAL.]

[Plants that have a proceduralized capability to cross-tie AC power from an off-site power supply of a companion unit may take credit for the redundant power source in the associated EAL for this IC.]

COLD SHUTDOWN / REFUELING SYSTEM MALFUNCTION

CU4

Initiating Condition -- NOTIFICATION OF UNUSUAL EVENT

UNPLANNED loss of decay heat removal capability with irradiated fuel in the RPV.

Operating Mode Applicability: Cold Shutdown, Refueling

Example Emergency Action Levels: (1 or 2)

Note: The Emergency Director should not wait until the applicable time has elapsed, but should declare the event as soon as it is determined that the condition will likely exceed the applicable time.

1. UNPLANNED event results in RCS temperature exceeding the Technical Specification cold shutdown temperature limit.
2. Loss of all RCS temperature and RCS/RPV level indication for 15 minutes or longer.

Basis:

This IC is be a precursor of more serious conditions and, as a result, is considered to be a potential degradation of the level of safety of the plant. In cold shutdown the ability to remove decay heat relies primarily on forced cooling flow. Operation of the systems that provide this forced cooling may be jeopardized due to the unlikely loss of electrical power or RCS inventory. Since the RCS usually remains intact in the cold shutdown mode a large inventory of water is available to keep the core covered.

[Entry into cold shutdown conditions may be attained within hours of operating at power. Entry into the refueling mode procedurally may not occur for typically 100 hours (site specific) or longer after the reactor has been shutdown. Thus the heatup threat and therefore the threat to damaging the fuel clad may be lower for events that occur in the refueling mode with irradiated fuel in the RPV (note that the heatup threat could be lower for cold shutdown conditions if the entry into cold shutdown was following a refueling). In addition, the operators should be able to monitor RCS temperature and RPV level so that escalation to the alert level via CA4 or CA1 will occur if required.]

During refueling the level in the RPV will normally be maintained above the RPV flange. Refueling evolutions that decrease water level below the RPV flange are carefully planned and procedurally controlled. Loss of forced decay heat removal at reduced inventory may result in more rapid increases in RCS/RPV temperatures depending on the time since shutdown.

[Unlike the cold shutdown mode,] normal means of core temperature indication and RCS level indication may not be available in the refueling mode. Redundant means of RPV level indication are therefore procedurally installed to assure that the ability to monitor level will not be interrupted. However, if all level and temperature indication were to be lost in either the cold shutdown of refueling modes, EAL 2 would result in declaration of a NOUE if both temperature and level indication cannot be restored within 15 minutes from the loss of both means of indication. Escalation to Alert would be via CA1 based on an inventory loss or CA4 based on exceeding its temperature criteria.

COLD SHUTDOWN / REFUELING SYSTEM MALFUNCTION

CU6

Initiating Condition -- NOTIFICATION OF UNUSUAL EVENT

Loss of all On-site or Off-site communications capabilities.

Operating Mode Applicability: Cold Shutdown, Refueling, Defueled

Example Emergency Action Levels: (1 or 2)

1. Loss of all of the following on-site communication methods affecting the ability to perform routine operations:

(site specific list of communications methods)
2. Loss of all of the following off-site communication methods affecting the ability to perform offsite notifications:

(site specific list of communications methods)

Basis:

The purpose of this IC and its associated EALs is to recognize a loss of communications capability that either defeats the plant operations staff ability to perform routine tasks necessary for plant operations or the ability to communicate issues with off-site authorities. The loss of off-site communications ability is expected to be significantly more comprehensive than the condition addressed by 10 CFR 50.72.

The availability of one method of ordinary off-site communications is sufficient to inform federal, state, and local authorities of plant issues. This EAL is intended to be used only when extraordinary means (e.g., relaying of information from radio transmissions, individuals being sent to off-site locations, etc.) are being utilized to make communications possible.

[Site specific list for on-site communications loss must encompass the loss of all means of routine communications (e.g., commercial telephones, sound powered phone systems, page party system and radios / walkie talkies).

Site specific list for off-site communications loss must encompass the loss of all means of communications with off-site authorities. This should include the ENS, commercial telephone lines, telecopy transmissions, and dedicated phone systems.]

COLD SHUTDOWN / REFUELING SYSTEM MALFUNCTION

CU7

Initiating Condition -- NOTIFICATION OF UNUSUAL EVENT

Loss of required DC power for 15 minutes or longer.

Operating Mode Applicability: Cold Shutdown, Refueling

Example Emergency Action Level:

Note: The Emergency Director should not wait until the applicable time has elapsed, but should declare the event as soon as it is determined that the condition will likely exceed the applicable time.

1. Less than (site specific bus voltage indication) on required (site specific Vital DC busses) for 15 minutes or longer.

Basis:

The purpose of this IC and its associated EALs is to recognize a loss of DC power compromising the ability to monitor and control the removal of decay heat during Cold Shutdown or Refueling operations.

[This EAL is intended to be anticipatory in as much as the operating crew may not have necessary indication and control of equipment needed to respond to the loss.]

[Plants will routinely perform maintenance on a Train related basis during shutdown periods. The required busses are the minimum allowed by Technical Specifications for the mode of operation.] It is intended that the loss of the operating (operable) train is to be considered. If this loss results in the inability to maintain cold shutdown, the escalation to an Alert will be per CA4.

[(Site specific) bus voltage should be based on the minimum bus voltage necessary for the operation of safety related equipment. This voltage value should incorporate a margin of at least 15 minutes of operation before the onset of inability to operate those loads. This voltage is usually near the minimum voltage selected when battery sizing is performed. Typically the value for the entire battery set is approximately 105 VDC. For a 60 cell string of batteries the cell voltage is typically 1.75 Volts per cell. For a 58 string battery set the minimum voltage is typically 1.81 Volts per cell.]

Fifteen minutes was selected as a threshold to exclude transient or momentary power losses.

COLD SHUTDOWN / REFUELING SYSTEM MALFUNCTION

CU8

Initiating Condition -- NOTIFICATION OF UNUSUAL EVENT

Inadvertent criticality.

Operating Mode Applicability: Cold Shutdown, Refueling

Example Emergency Action Levels:

1. UNPLANNED sustained positive period observed on nuclear instrumentation. (BWR)
1. UNPLANNED sustained positive startup rate observed on nuclear instrumentation. (PWR)

Basis:

This IC addresses criticality events that occur in Cold Shutdown or Refueling modes [(NUREG 1449, *Shutdown and Low-Power Operation at Commercial Nuclear Power Plants in the United States*)] such as fuel mis-loading events and inadvertent dilution events. This IC indicates a potential degradation of the level of safety of the plant, warranting a NOUE classification.

[This condition can be identified using period monitors/startup rate monitor. The term "sustained" is used in order to allow exclusion of expected short term positive periods/startup rates from planned fuel bundle or control rod movements during core alteration for PWRs and BWRs. These short term positive periods/startup rates are the result of the increase in neutron population due to subcritical multiplication.]

Escalation would be by Emergency Director Judgment.

COLD SHUTDOWN / REFUELING SYSTEM MALFUNCTION

CA1

Initiating Condition - ALERT

Loss of RCS/RPV inventory.

Operating Mode Applicability: Cold Shutdown, Refueling

Example Emergency Action Levels: (1 or 2)

Note: The Emergency Director should not wait until the applicable time has elapsed, but should declare the event as soon as it is determined that the condition will likely exceed the applicable time.

1. Loss of RCS/RPV inventory as indicated by level less than (site specific level).
[Low-Low ECCS actuation setpoint / Level 2 (BWR)]
[Bottom ID of the RCS loop (PWR)]
2. RCS/RPV level cannot be monitored for 15 minutes or longer with a loss of RCS/RPV inventory as indicated by an unexplained level rise in (site specific sump or tank).

Basis:

These EALs serve as precursors to a loss of ability to adequately cool the fuel. The magnitude of this loss of water indicates that makeup systems have not been effective and may not be capable of preventing further RPV level decrease and potential core uncover. This condition will result in a minimum emergency classification level of an Alert.

EAL #1

[The BWR Low-Low ECCS Actuation Setpoint/Level 2 was chosen because it is a standard setpoint at which some available injection systems automatically start. The PWR Bottom ID of the RCS Loop Setpoint was chosen because at this level remote RCS level indication may be lost and loss of suction to decay heat removal systems has occurred. The Bottom ID of the RCS Loop Setpoint should be the level equal to the bottom of the RPV loop penetration (not the low point of the loop).]

The inability to restore and maintain level after reaching this setpoint would be indicative of a failure of the RCS barrier.

EAL #2

[In the cold shutdown mode, normal RCS level and RPV level instrumentation systems will usually be available. In the refueling mode, normal means of RPV level indication may not be available. Redundant means of RPV level indication will usually be installed (including the ability to monitor level visually) to assure that the ability to monitor level will not be interrupted. However, if all level indication were to be lost during a loss of RCS inventory event, the operators would need to determine that RPV inventory loss was occurring by observing sump and tank level changes. Sump and tank level increases must be evaluated against other

COLD SHUTDOWN / REFUELING SYSTEM MALFUNCTION

potential sources of leakage such as cooling water sources inside the containment to ensure they are indicative of RCS leakage.]

[The 15-minute duration for the loss of level indication was chosen because it is half of the CS1 Site Area Emergency EAL duration. Significant fuel damage is not expected to occur until the core has been uncovered for greater than 1 hour per the analysis referenced in the CG1 basis. Therefore this EAL meets the definition for an Alert.]

If RPV level continues to lower then escalation to Site Area Emergency will be via CS1.

COLD SHUTDOWN / REFUELING SYSTEM MALFUNCTION

CA3

Initiating Condition - ALERT

Loss of all Off-site and all On-Site AC power to emergency busses for 15 minutes or longer.

Operating Mode Applicability: Cold Shutdown, Refueling, Defueled

Example Emergency Action Level:

Note: The Emergency Director should not wait until the applicable time has elapsed, but should declare the event as soon as it is determined that the condition will likely exceed the applicable time.

1. Loss of all Off-Site and all On-Site AC Power to (site specific emergency busses) for 15 minutes or longer.

Basis:

Loss of all AC power compromises all plant safety systems requiring electric power including RHR, ECCS, Containment Heat Removal, Spent Fuel Heat Removal and the Ultimate Heat Sink.

The event can be classified as an Alert when in cold shutdown, refueling, or defueled mode because of the significantly reduced decay heat and lower temperature and pressure, increasing the time to restore one of the emergency busses, relative to that specified for the Site Area Emergency EAL.

Escalating to Site Area Emergency, if appropriate, is by Abnormal Rad Levels / Radiological Effluent ICs.

Fifteen minutes was selected as a threshold to exclude transient or momentary power losses.

[The companion IC is SS1].

COLD SHUTDOWN / REFUELING SYSTEM MALFUNCTION

CA4

Initiating Condition - ALERT

Inability to maintain plant in cold shutdown.

Operating Mode Applicability: Cold Shutdown, Refueling

Example Emergency Action Levels: (1 or 2)

1. An UNPLANNED event results in RCS temperature greater than (site specific Technical Specification cold shutdown temperature limit) for greater than the specified duration on table.

Table: RCS Reheat Duration Thresholds		
RCS	Containment Closure	Duration
Intact (but not RCS Reduced Inventory [PWR])	N/A	60 minutes*
Not intact or RCS Reduced Inventory (PWR)	Established	20 minutes*
	Not Established	0 minutes

* If an RCS heat removal system is in operation within this time frame and RCS temperature is being reduced, the EAL is not applicable.

2. An UNPLANNED event results in RCS pressure increase greater than 10 psi due to a loss of RCS cooling. (PWR-This EAL does not apply in Solid Plant conditions.)

Basis:

For EAL 1, the RCS Reheat Duration Threshold table addresses complete loss of functions required for core cooling for greater than 60 minutes during refueling and cold shutdown modes when RCS integrity is established. *[RCS integrity should be considered to be in place when the RCS pressure boundary is in its normal condition for the cold shutdown mode of operation (e.g., no freeze seals or nozzle dams). The status of CONTAINMENT CLOSURE in this condition is immaterial given that the RCS is providing a high pressure barrier to fission product release to the environment.]* The 60 minute time frame should allow sufficient time to restore cooling without there being a substantial degradation in plant safety.

The RCS Reheat Duration Threshold table also addresses the complete loss of functions required for core cooling for greater than 20 minutes during refueling and cold shutdown modes when CONTAINMENT CLOSURE is established but RCS integrity is not established or RCS inventory is reduced *[(e.g., mid-loop operation in PWRs)]. [As discussed above, RCS integrity should be assumed to be in place when the RCS pressure boundary is in its normal condition for the cold shutdown mode of operation (e.g., no freeze seals or nozzle dams).]* The allowed 20 minute time frame was included to allow operator action to restore the heat removal function, if possible. *[The allowed time frame is consistent with the guidance provided by Generic Letter 88-17, "Loss of Decay Heat Removal" (discussed later in this basis) and is believed to be*

COLD SHUTDOWN / REFUELING SYSTEM MALFUNCTION

conservative given that a low pressure Containment barrier to fission product release is established.]

Finally, complete loss of functions required for core cooling during refueling and cold shutdown modes when neither CONTAINMENT CLOSURE nor RCS integrity are established. *[RCS integrity is in place when the RCS pressure boundary is in its normal condition for the cold shutdown mode of operation (e.g., no freeze seals or nozzle dams). No delay time is allowed because the evaporated reactor coolant that may be released into the Containment during this heatup condition could also be directly released to the environment.]*

The note (*) indicates that this EAL is not applicable if actions are successful in restoring an RCS heat removal system to operation and RCS temperature is being reduced within the specified time frame.

In EAL 2, the 10 psi pressure increase addresses situations where, due to high decay heat loads, the time provided to restore temperature control, should be less than 60 minutes. The RCS pressure setpoint chosen should be 10 psi or the lowest pressure that the site can read on installed Control Board instrumentation that is equal to or greater than 10 psi.

Escalation to Site Area Emergency would be via CS1 should boiling result in significant RPV level loss leading to core uncover.

[For PWRs, this IC and its associated EALs are based on concerns raised by Generic Letter 88-17, "Loss of Decay Heat Removal." A number of phenomena such as pressurization, vortexing, steam generator U-tube draining, RCS level differences when operating at a mid-loop condition, decay heat removal system design, and level instrumentation problems can lead to conditions where decay heat removal is lost and core uncover can occur. NRC analyses show that there are sequences that can cause core uncover in 15 to 20 minutes and severe core damage within an hour after decay heat removal is lost.]

A loss of Technical Specification components alone is not intended to constitute an Alert. The same is true of a momentary UNPLANNED excursion above the Technical Specification cold shutdown temperature limit when the heat removal function is available.

The Emergency Director must remain alert to events or conditions that lead to the conclusion that exceeding the EAL is IMMINENT. If, in the judgment of the Emergency Director, an IMMINENT situation is at hand, the classification should be made as if the threshold has been exceeded.

COLD SHUTDOWN / REFUELING SYSTEM MALFUNCTION

CS1

Initiating Condition - SITE AREA EMERGENCY

Loss of RCS/RPV inventory affecting core decay heat removal capability.

Operating Mode Applicability: Cold Shutdown, Refueling

Example Emergency Action Levels: (1 or 2 or 3)

Note: The Emergency Director should not wait until the applicable time has elapsed, but should declare the event as soon as it is determined that the condition will likely exceed the applicable time.

1. With CONTAINMENT CLOSURE not established, RCS/RPV level less than (site specific level).

[6" below the bottom ID of the RCS loop (PWR)]

[6" below the low-low ECCS actuation setpoint (BWR)]

OR

2. With CONTAINMENT CLOSURE established, RCS/RPV level less than (site specific level for TOAF).

OR

3. RCS/RPV level cannot be monitored for 30 minutes or longer with a loss of RCS/RPV inventory as indicated by **ANY** of the following:

- (Site specific radiation monitor) reading greater than (site specific value).
- Erratic Source Range Monitor Indication.
- Unexplained level rise in (site specific sump or tank).

Basis:

Under the conditions specified by this IC, continued decrease in RCS/RPV level is indicative of a loss of inventory control. Inventory loss may be due to an RCS breach, pressure boundary leakage, or continued boiling in the RPV. Thus, declaration of a Site Area Emergency is warranted.

Escalation to a General Emergency is via CG1 or AG1.

EAL #1

[6" below the bottom ID of the RCS Loop should be the level equal to 6" below the bottom of the RPV loop penetration (not the low point of the loop). PWRs unable to measure this level should choose the first observable point below the bottom ID of the loop as the EAL value. If a water

COLD SHUTDOWN / REFUELING SYSTEM MALFUNCTION

level instrument is not available such that the PWR EAL value cannot be determined, then EAL 3 should be used to determine if the IC has been met.]

[Since BWRs have RCS penetrations below the EAL value, continued level decrease may be indicative of pressure boundary leakage.]

EAL #3

[In the cold shutdown mode, normal RCS level and RPV level instrumentation systems will usually be available. In the refueling mode, normal means of RPV level indication may not be available. Redundant means of RPV level indication will usually be installed (including the ability to monitor level visually) to assure that the ability to monitor level will not be interrupted. However, if all level indication were to be lost during a loss of RCS inventory event, the operators would need to determine that RPV inventory loss was occurring by observing sump and tank level changes. Sump and tank level increases must be evaluated against other potential sources of leakage such as cooling water sources inside the containment to ensure they are indicative of RCS leakage.]

The 30-minute duration allows sufficient time for actions to be performed to recover inventory control equipment.

As water level in the RPV lowers, the dose rate above the core will increase. The dose rate due to this core shine should result in site specific monitor indication and possible alarm.

[This EAL should conservatively estimate a site specific dose rate setpoint indicative of core uncover (i.e., level at TOAF). For BWRs that do not have installed radiation monitors capable of indicating core uncover, alternate site specific level indications of core uncover should be used.]

[Post-TMI studies indicated that the installed nuclear instrumentation will operate erratically when the core is uncovered and that this should be used as a tool for making such determinations.]

COLD SHUTDOWN / REFUELING SYSTEM MALFUNCTION

CG1

Initiating Condition - GENERAL EMERGENCY

Loss of RCS/RPV inventory affecting fuel clad integrity with containment challenged.

Operating Mode Applicability: Cold Shutdown, Refueling

Example Emergency Action Level: (1 or 2)

Note: The Emergency Director should not wait until the applicable time has elapsed, but should declare the event as soon as it is determined that the condition will likely exceed the applicable time.

1. a. RCS/RPV level less than (site specific level for TOAF) for 30 minutes or longer.
AND
 - b. **ANY** containment challenge indication (see Table):
2. a. RCS/RPV level cannot be monitored with core uncover indicated by **ANY** of the following for 30 minutes or longer.
 - (Site specific radiation monitor) reading greater than (site specific setpoint).
 - Erratic source range monitor indication
 - UNPLANNED level rise in (site specific sump or tank).
 - *[Other site specific indications]***AND**
 - b. **ANY** containment challenge indication (see Table):

Table: Containment Challenge Indications

<ul style="list-style-type: none">• CONTAINMENT CLOSURE not established.• (Site specific explosive mixture) inside containment.• UNPLANNED rise in containment pressure.• Secondary containment radiation monitor reading above (site specific value). <i>[BWR only]</i>

Basis:

This IC represents the inability to restore and maintain RPV level to above the top of active fuel with containment challenged. Fuel damage is probable if RPV level cannot be restored, as available decay heat will cause boiling, further reducing the RPV level. With the CONTAINMENT breached or challenged then the potential for unmonitored fission product release to the environment is high. This represents a direct path for radioactive inventory to be

COLD SHUTDOWN / REFUELING SYSTEM MALFUNCTION

released to the environment. This is consistent with the definition of a GE. The GE is declared on the occurrence of the loss or IMMEDIATE loss of function of all three barriers.

[These EALs are based on concerns raised by Generic Letter 88-17, Loss of Decay Heat Removal, SECY 91-283, Evaluation of Shutdown and Low Power Risk Issues, NUREG-1449, Shutdown and Low-Power Operation at Commercial Nuclear Power Plants in the United States, and, NUMARC 91-06, Guidelines for Industry Actions to Assess Shutdown Management.]

A number of variables can have a significant impact on heat removal capability challenging the fuel clad barrier. Examples include:

- [BWRs] initial vessel level, shutdown heat removal system design
- [PWRs] mid-loop, reduced level/flange level, head in place, cavity flooded, RCS venting strategy, decay heat removal system design, vortexing pre-disposition, steam generator U-tube draining

Analysis indicates that core damage may occur within an hour following continued core uncovering therefore, 30 minutes was conservatively chosen.

If CONTAINMENT CLOSURE is re-established prior to exceeding the 30 minute core uncovering time limit then escalation to GE would not occur.

[Site shutdown contingency plans typically provide for re-establishing CONTAINMENT CLOSURE following a loss of heat removal or RCS inventory functions.]

[In the early stages of a core uncovering event, it is unlikely that hydrogen buildup due to a core uncovering could result in an explosive mixture of dissolved gasses in Containment. However, Containment monitoring and/or sampling should be performed to verify this assumption and a General Emergency declared if it is determined that an explosive mixture exists.]

[For BWRs, the use of secondary containment radiation monitors should provide indication of increased release that may be indicative of a challenge to secondary containment. The site specific radiation monitor values should be based on the EOP "maximum safe values" because these values are easily recognizable and have an emergency basis.]

EAL #2

Sump and tank level increases must be evaluated against other potential sources of leakage such as cooling water sources inside the containment to ensure they are indicative of RCS leakage.

[In the cold shutdown mode, normal RCS level and RPV level instrumentation systems will usually be available. In the refueling mode, normal means of RPV level indication may not be available. Redundant means of RPV level indication will usually be installed (including the ability to monitor level visually) to assure that the ability to monitor level will not be interrupted. However, if all level indication were to be lost during a loss of RCS inventory event, the operators would need to determine that RPV inventory loss was occurring by observing sump and tank level changes. Sump and tank level increases must be evaluated against other potential sources of leakage such as cooling water sources inside the containment to ensure they are indicative of RCS leakage.]

COLD SHUTDOWN / REFUELING SYSTEM MALFUNCTION

As water level in the RPV lowers, the dose rate above the core will increase. The dose rate due to this core shine should result in site specific monitor indication and possible alarm.

[This EAL should conservatively estimate a site specific dose rate setpoint indicative of core uncover (ie., level at TOAF). For BWRs that do not have installed radiation monitors capable of indicating core uncover, alternate site specific level indications of core uncover should be used.]

[Post-TMI studies indicated that the installed nuclear instrumentation will operate erratically when the core is uncovered and that this should be used as a tool for making such determinations.]

5.7 PERMANENTLY DEFUELED STATION EALs

Table 5-D-1: Recognition Category “D” Initiating Condition Matrix

ALERT	UNUSUAL EVENT
D-AA1 Any release of gaseous or liquid radioactivity to the environment greater than 200 times the Radiological Effluent Technical Specification/ODCM for 15 minutes or longer. <i>Op. Modes: Not Applicable</i>	D-AU1 Any release of gaseous or liquid radioactivity to the environment greater than 2 times the Radiological Effluent Technical Specification/ODCM for 60 minutes or longer. <i>Op. Modes: Not Applicable</i>
D-AA2 UNPLANNED rise in plant radiation levels that impedes plant access required to maintain spent fuel integrity. <i>Op. Modes: Not Applicable</i>	D-AU2 UNPLANNED rise in plant radiation levels. <i>Op. Modes: Not Applicable</i>
D-HA1 HOSTILE ACTION within the fuel building or control room. <i>Op. Modes: Not Applicable</i>	D-SU1 UNPLANNED Spent Fuel Pool temperature rise. <i>Op. Modes: Not Applicable</i>
D-HA2 Other conditions exist which in the judgment of the Emergency Director warrant declaration of an Alert. <i>Op. Modes: Not Applicable</i>	D-HU1 Confirmed SECURITY CONDITION or threat which indicates a potential degradation in the level of safety of the plant. <i>Op. Modes: Not Applicable</i>
	D-HU2 Other conditions exist which in the judgment of the Emergency Director warrant declaration of an Unusual Event. <i>Op. Modes: Not Applicable</i>
	D-HU3 Natural or destructive phenomena inside the PROTECTED AREA affecting the ability to maintain spent fuel integrity. <i>Op. Modes: Not Applicable</i>

PERMANENTLY DEFUELED STATION SYSTEM MALFUNCTION

D-AU1

Initiating Condition - NOTIFICATION OF UNUSUAL EVENT

Any release of gaseous or liquid radioactivity to the environment greater than 2 times the Radiological Effluent Technical Specifications for 60 minutes or longer.

Operating Mode Applicability: Not Applicable

Example Emergency Action Levels: (1 or 2)

Note: The Emergency Director should not wait until the applicable time has elapsed, but should declare the event as soon as it is determined that the release duration has exceeded, or will likely exceed, the applicable time. In the absence of data to the contrary, assume that the release duration has exceeded the applicable time if an ongoing release is detected and the release start time is unknown.

1. VALID reading on **ANY** of the following radiation monitors greater than the reading shown for 60 minutes or longer.

(site specific monitor list and threshold values)

2. Confirmed sample analyses for gaseous or liquid releases indicate concentrations or release rates greater than (2 times site specific technical specification values) for 60 minutes or longer.

Basis:

[Refer to Appendix D for a detailed basis of the radiological effluent IC/EALs.]

[Defueled power plants incorporate features intended to control the release of radioactive effluents to the environment. Further, there are administrative controls established to prevent unintentional releases. These controls are located in the Radiological Effluent Technical Specifications (RETS). The occurrence of extended, uncontrolled radioactive releases to the environment is indicative of a degradation in these features and/or controls.]

The RETS multiples are specified in D-AU1 and D-AA1 only to distinguish between non-emergency conditions, and from each other. While these multiples obviously correspond to an off-site dose or dose rate, the emphasis in classifying these events is the degradation in the level of safety of the plant, not the magnitude of the associated dose or dose rate.

[Releases should not be prorated or averaged. For example, a release exceeding 4x ODCM for 30 minutes does not meet the threshold.]

EAL #1

[This value ensures compliance with 10CFR20.1301 dose limits to the public. This value also ensures the concentration of liquid effluents released is less than 2 times the value specified in 10CFR20, Appendix B.]

PERMANENTLY DEFUELED STATION SYSTEM MALFUNCTION

EAL #2

[The grab samples are used to determine gaseous release rates or liquid concentrations to confirm monitor readings or when the effluent monitors are not in service.]

PERMANENTLY DEFUELED STATION SYSTEM MALFUNCTION

D-AU2

Initiating Condition - NOTIFICATION OF UNUSUAL EVENT

UNPLANNED rise in plant radiation levels.

Operating Mode Applicability: Not Applicable

Example Emergency Action Level: (1 or 2)

1. a. UNPLANNED water level drop in the spent fuel pool as indicated by (site specific level or indication).

AND

- - b. VALID Area Radiation Monitor reading rise on (site specific list).
2. UNPLANNED Area Radiation Monitor readings or survey results indicate a rise by 25 mR/hr over normal* levels.

*Normal can be considered as the highest reading in the past twenty-four hours excluding the current peak value.

Basis:

This IC addresses increased radiation levels as a result of water level decreases above irradiated fuel or events that have resulted, or may result, in UNPLANNED increases in radiation dose rates within plant buildings. These radiation increases represent a loss of control over radioactive material and represent a potential degradation in the level of safety of the plant.

EAL #1

[Site specific indications may include instrumentation such as water level and local area radiation monitors, and personnel reports. If available, video cameras may allow remote observation. Depending on available level instrumentation, the declaration threshold may need to be based on indications of water makeup rate or decrease in water storage tank level.]

PERMANENTLY DEFUELED STATION SYSTEM MALFUNCTION

D-SU1

Initiating Condition - NOTIFICATION OF UNUSUAL EVENT

UNPLANNED spent fuel pool temperature rise.

Operating Mode Applicability: Not Applicable

Example Emergency Action Levels:

1. UNPLANNED Spent Fuel Pool temperature rise greater than (site specific ° F).

Basis:

Classification of a NOUE for the EAL value is warranted as a precursor to more serious events and a potential degradation in the level of safety of the plant. Since loss of level or continued pool boiling would result in increased radiation levels exceeding the criteria of D-AA2, continued system related loss of level type events are bounded by D-AA2.

[The site specific temperature should be chosen based on the initial temperature starting point for fuel damage calculations (typically 125 to 150° F) in the Safety Analysis Report (SAR).]

PERMANENTLY DEFUELED STATION SYSTEM MALFUNCTION

D-HU1

Initiating Condition - NOTIFICATION OF UNUSUAL EVENT

Confirmed SECURITY CONDITION or threat which indicates a potential degradation in the level of safety of the plant.

Operating Mode Applicability: Not Applicable

Example Emergency Action Levels: (1 or 2)

1. SECURITY CONDITION that does not involve a HOSTILE ACTION as reported by the (site specific security shift supervision).
2. A credible site specific security threat notification.

Basis:

Security events which do not represent a potential degradation in the level of safety of the plant are reported under 10 CFR 73.71 or in some cases under 10 CFR 50.72. Security events assessed as HOSTILE ACTIONS are classifiable under D-HA1.

A higher initial classification could be made based upon the nature and timing of the security threat and potential consequences. The licensee shall consider upgrading the emergency response status and emergency classification level in accordance with the site's Safeguards Contingency Plan and Emergency Plan.

EAL #1

Reference is made to site specific security shift supervision because these individuals are the designated personnel on-site qualified and trained to confirm that a security event is occurring or has occurred. Training on security event classification confirmation is closely controlled due to the strict secrecy controls placed on the plant Safeguards Contingency Plan.

This threshold is based on site specific security plans. Site specific Safeguards Contingency Plans are based on guidance provided by NEI 03-12.

EAL #2

This threshold is included to ensure that appropriate notifications for the security threat are made in a timely manner. This includes information of a credible threat. Only the plant to which the specific threat is made need declare the Notification of an Unusual Event.

The determination of "credible" is made through use of information found in the site specific Safeguards Contingency Plan.

PERMANENTLY DEFUELED STATION SYSTEM MALFUNCTION

D-HU2

Initiating Condition - NOTIFICATION OF UNUSUAL EVENT

Other conditions exist which in the judgment of the Emergency Director warrant declaration of an UNUSUAL EVENT.

Operating Mode Applicability: Not Applicable

Example Emergency Action Levels:

1. Other conditions exist which in the judgment of the Shift Supervisor / Emergency Director indicate that events are in progress or have occurred which indicate a potential degradation in the level of safety of the plant or indicate a security threat to facility protection has been initiated. No releases of radioactive material requiring off-site response or monitoring are expected unless further degradation of safety systems occurs.

Basis:

This EAL addresses unanticipated conditions not addressed explicitly elsewhere but that warrant declaration of an emergency because conditions exist which are believed by the Emergency Director to fall under the NOUE emergency classification level.

PERMANENTLY DEFUELED STATION SYSTEM MALFUNCTION

D-HU3

Initiating Condition - NOTIFICATION OF UNUSUAL EVENT

Natural or destructive phenomena inside the PROTECTED AREA affecting the ability to maintain spent fuel integrity.

Operating Mode Applicability: Not Applicable

Example Emergency Action Levels: (1 or 2 or 3 or 4 or 5 or 6 or 7 or 8)

1. Seismic event identified by **ANY** 2 of the following:
 - Seismic event confirmed by (site specific indication or method)
 - Earthquake felt in plant
 - National Earthquake Center
2. Tornado striking or high winds greater than (site specific mph) within the PROTECTED AREA that have the potential to affect equipment needed to maintain spent fuel integrity.
3. Internal flooding that has the potential to affect equipment needed to maintain spent fuel integrity in **ANY** of the following areas.

(site specific area list)
4. Vehicle crash within the PROTECTED AREA that has the potential to affect equipment needed to maintain spent fuel integrity.
5. FIRE not extinguished within 15 minutes of control room notification or verification of a control room FIRE alarm that has the potential to affect equipment needed to maintain spent fuel integrity in **ANY** of the following areas:

(site specific area list)
6. EXPLOSION within the PROTECTED AREA resulting in VISIBLE DAMAGE that has the potential to affect equipment needed to maintain spent fuel integrity.
7. Toxic, corrosive, asphyxiant, or flammable gas within the PROTECTED AREA that has the potential to affect the operation of equipment needed to maintain spent fuel integrity.
8. (Site specific occurrences affecting the PROTECTED AREA that have the potential to affect equipment needed to maintain spent fuel integrity).

Basis:

NOUE in this IC are categorized on the basis of the occurrence of an event of sufficient magnitude to be of concern to plant operators. Areas identified in the EALs define the location of the event based on the potential for damage to equipment contained therein.

PERMANENTLY DEFUELED STATION SYSTEM MALFUNCTION

Escalation of the emergency classification level, if appropriate, will be based on increasing radiation levels via D-AA2.

EAL #1

Damage may be caused to some portions of the site, but should not affect ability to operate spent fuel pool equipment.

As defined in the EPRI-sponsored Guidelines for Nuclear Plant Response to an Earthquake, dated October 1989, a "felt earthquake" is: An earthquake of sufficient intensity such that: (a) the vibratory ground motion is felt at the nuclear plant site and recognized as an earthquake based on a consensus of control room operators on duty at the time, and (b) for plants with operable seismic instrumentation, the seismic switches of the plant are activated.

[For most plants with seismic instrumentation, the seismic switches are set at an acceleration of about 0.01g. This EAL should be developed on site specific basis. The method of detection can be based on instrumentation, validated by a reliable source, or operator assessment.]

The National Earthquake Center can confirm if an earthquake has occurred in the area of the plant.

EAL #2

This EAL is based on a tornado striking (touching down) or high winds within the PROTECTED AREA may have potentially damaged plant structures containing functions or systems required to maintain spent fuel integrity.

[The high wind value should be based on site specific FSAR design basis as long as it is within the range of the instrumentation available for wind speed.]

EAL #3

This EAL addresses the effect of internal flooding caused by events such as component failures or equipment misalignment that has the potential to affect equipment needed to maintain spent fuel integrity.

[The site specific areas include those areas that contain systems required to maintain fuel integrity, which are not designed to be partially or fully submerged. The plant's IPEEE may provide insight into areas to be considered when developing this EAL.]

EAL #4

This EAL addresses vehicles crashes within the PROTECTED AREA that results in significant damage to plant structures containing functions and systems necessary to maintain spent fuel integrity.

EAL #5

This EAL addresses FIRES that have the potential to affect the ability to maintain spent fuel integrity.

The 15 minute time period begins with a credible notification that a FIRE is occurring, or indication of a fire detection system alarm/actuation. Verification of a fire detection system alarm/actuation includes actions that can be taken with the control room or other nearby site

PERMANENTLY DEFUELED STATION SYSTEM MALFUNCTION

specific location to ensure that it is not spurious. An alarm is assumed to be an indication of a FIRE unless it is disproved within the 15 minute period by personnel dispatched to the scene. In other words, a personnel report from the scene may be used to disprove a sensor alarm if received within 15 minutes of the alarm, but shall not be required to verify the alarm.]

The intent of this 15 minute duration is to size the FIRE and to discriminate against small FIRES that are readily extinguished (e.g., smoldering waste paper basket).

[The site specific list should be limited and applies to buildings and areas containing equipment important to maintaining spent fuel integrity. This excludes FIRES within administration buildings, waste-basket FIRES, and other small FIRES of no safety consequence.]

EAL #6

This EAL addresses only those EXPLOSIONS of sufficient force to damage equipment needed to maintain spent fuel integrity.

No attempt is made to assess the actual magnitude of the damage. The occurrence of the EXPLOSION with reports of damage is sufficient for declaration.

The Emergency Director also needs to consider any security aspects of the EXPLOSION.

EAL #7

This EAL addresses toxic, corrosive, asphyxiant or flammable gas in the PROTECTED AREA that has the potential to affect the ability to maintain spent fuel integrity due to the evacuation of personnel preventing operation or maintenance of spent fuel pool equipment.

EAL #8

This EAL addresses other site specific phenomena (such as hurricane, flood, or seiche) that have the potential to result loss of spent fuel integrity.

PERMANENTLY DEFUELED STATION SYSTEM MALFUNCTION

D-AA1

Initiating Condition - ALERT

Any release of gaseous or liquid radioactivity to the environment greater than 200 times the Radiological Effluent Technical Specifications/ODCM for 15 minutes or longer.

Operating Mode Applicability: Not Applicable

Example Emergency Action Levels: (1 or 2)

Note: The Emergency Director should not wait until the applicable time has elapsed, but should declare the event as soon as it is determined that the release duration has exceeded, or will likely exceed, the applicable time. In the absence of data to the contrary, assume that the release duration has exceeded the applicable time if an ongoing release is detected and the release start time is unknown.

1. UNPLANNED VALID reading on **ANY** of the following radiation monitors greater than the reading shown for 15 minutes or longer.
2. Confirmed sample analyses for gaseous or liquid releases indicate concentrations or release rates greater than 200 times (site specific technical specification values) for 15 minutes or longer.

Basis:

[Refer to Appendix D for a detailed basis of the radiological effluent IC/EALs.]

The RETS multiples are specified in D-AU1 and D-AA1 only to distinguish between non-emergency conditions, and from each other. While these multiples obviously correspond to an off-site dose or dose rate, the emphasis in classifying these events is the degradation in the level of safety of the plant, not the magnitude of the associated dose or dose rate.

[Releases should not be prorated or averaged. For example, a release exceeding 600x ODCM for 5 minutes does not meet the threshold.]

EAL #1

[This value ensures compliance with 10CFR20.1301 dose limits to the public. This limit also ensures the concentration of liquid effluents is less than 200 times the value specified in 10CFR20, Appendix B.]

EAL #2

[The grab samples are used to determine gaseous release rates or liquid concentrations to confirm monitor readings or when the effluent monitors are not in service.]

PERMANENTLY DEFUELED STATION SYSTEM MALFUNCTION

D-AA2

Initiating Condition - ALERT

UNPLANNED rise in plant radiation levels that impedes plant access required to maintain spent fuel integrity.

Operating Mode Applicability: Not Applicable

Example Emergency Action Levels: (1 or 2)

1. UNPLANNED dose rate greater than 15 mR/hr in **ANY** of the following areas requiring continuous occupancy to maintain control of radioactive material or operation of systems needed to maintain spent fuel integrity:

(site specific area list)

2. UNPLANNED Area Radiation Monitor readings or survey results indicate a rise by 100 mR/hr over normal* levels that impedes access to **ANY** of the following areas needed to maintain control of radioactive material or operation of systems needed to maintain spent fuel integrity.

(site specific area list)

*Normal can be considered as the highest reading in the past twenty-four hours excluding the current peak value.

Basis:

This IC addresses increased radiation levels that impede necessary access to defueled stations, or other areas containing equipment that must be operated manually or that requires local monitoring, in order to maintain systems needed to maintain spent fuel integrity. It is this impaired access that results in the actual or potential substantial degradation of the level of safety of the plant.

This IC is not intended to apply to anticipated temporary increases due to planned events.

As used here, 'impede' includes hindering or interfering, provided that the interference or delay is sufficient to significantly threaten necessary plant access.

EAL #1

[The value of 15mR/hr is derived from the GDC 19 value of 5 rem in 30 days with adjustment for expected occupancy times. Although Section III.D.3 of NUREG-0737, "Clarification of TMI Action Plan Requirements", provides that the 15 mR/hr value can be averaged over the 30 days, the value is used here without averaging, as a 30 day duration implies an event potentially more significant than an Alert.]

PERMANENTLY DEFUELED STATION SYSTEM MALFUNCTION

D-HA1

Initiating Condition - ALERT

HOSTILE ACTION within the fuel building or control room.

Operating Mode Applicability: Not Applicable

Example Emergency Action Levels:

1. A HOSTILE ACTION is occurring or has occurred within the Fuel Building or control room as reported by the (site security shift supervision).

Basis:

This condition represents an escalated threat to plant safety above that contained in the Unusual Event in that a HOSTILE FORCE has progressed into the Fuel Handling Building or control room.

This EAL addresses the contingency for a very rapid progression of events, such as that experienced on September 11, 2001. It is not premised solely on the potential for a radiological release. Rather the issue includes the need for rapid assistance due to the possibility for significant and indeterminate damage from additional air, land or water attack elements.

The fact that the site is under serious attack with minimal time available for further preparation or additional assistance to arrive requires a heightened state of readiness and implementation of protective measures that can be effective (such as on-site evacuation, dispersal or sheltering).

This EAL addresses the potential for a very rapid progression of events due to a HOSTILE ACTION. It is not intended to address incidents that are accidental events or acts of civil disobedience, such as small aircraft impact, hunters, or physical disputes between employees. Those events are adequately addressed by other EALs.

PERMANENTLY DEFUELED STATION SYSTEM MALFUNCTION

D-HA2

Initiating Condition - ALERT

Other conditions exist which in the judgment of the Emergency Director warrant declaration of an Alert.

Operating Mode Applicability: Not Applicable

Example Emergency Action Levels:

1. Other conditions exist which in the judgment of the Emergency Director indicate that events are in progress or have occurred which involve actual or potential substantial degradation of the level of safety of the plant or a security event that involves probable life threatening risk to site personnel or damage to site equipment because of HOSTILE ACTION. Any releases are expected to be limited to small fractions of the EPA Protective Action Guideline exposure levels.

Basis:

A condition exists which, in the judgment of the Emergency Director, presents an actual or potential substantial degradation in the level of safety of the plant. Emergency Director judgment is to be based on known conditions and the expected response to mitigating activities.

5.8 IFSFI EALs

Table 5-E-1: Recognition Category “E” Initiating Condition Matrix

ALERT

UNUSUAL EVENT

Note: Security related events for IFSFIs are to be covered under the H Series recognition category.

E-HU1 Damage to a loaded cask CONFINEMENT BOUNDARY.
Op. Modes: Not Applicable

Initiating Condition - NOTIFICATION OF UNUSUAL EVENT

Damage to a loaded cask CONFINEMENT BOUNDARY.

Operating Mode Applicability: Not applicable

Example Emergency Action Level:

1. Damage to a loaded cask CONFINEMENT BOUNDARY.

Basis:

A NOUE in this IC is categorized on the basis of the occurrence of an event of sufficient magnitude that a loaded cask CONFINEMENT BOUNDARY is damaged or violated. This includes classification based on a loaded fuel storage cask CONFINEMENT BOUNDARY loss leading to the degradation of the fuel during storage or posing an operational safety problem with respect to its removal from storage.

[The results of the ISFSI Safety Analysis Report (SAR) per NUREG 1536 or SAR referenced in the cask(s) Certificate of Compliance and the related NRC Safety Evaluation Report identify natural phenomena events and accident conditions that could potentially effect the CONFINEMENT BOUNDARY. This EAL addresses a dropped cask, a tipped over cask, EXPLOSION, PROJECTILE damage, FIRE damage or natural phenomena affecting a cask (e.g., seismic event, tornado, etc.).]

5.9 FISSION PRODUCT BARRIER EALs

Table 5-F-1: Recognition Category “F” Initiating Condition Matrix

See Table 5-F-2 for BWR Thresholds
See Table 5-F-3 for PWR Thresholds

GENERAL EMERGENCY	
FG1	Loss of ANY Two Barriers AND Loss or Potential Loss of the third barrier. <i>Op. Modes: Power Operation, Hot Standby, Startup, Hot Shutdown</i>
SITE AREA EMERGENCY	
FS1	Loss or Potential Loss of ANY two barriers. <i>Op. Modes: Power Operation, Hot Standby, Startup, Hot Shutdown</i>
ALERT	
FA1	ANY Loss or ANY Potential Loss of EITHER Fuel Clad OR RCS. <i>Op. Modes: Power Operation, Hot Standby, Startup, Hot Shutdown</i>
UNUSUAL EVENT	
FU1	ANY Loss or ANY Potential Loss of Containment. <i>Op. Modes: Power Operation, Hot Standby, Startup, Hot Shutdown</i>

Note: The logic flow diagram is for use by developers and is not required for site specific implementation.

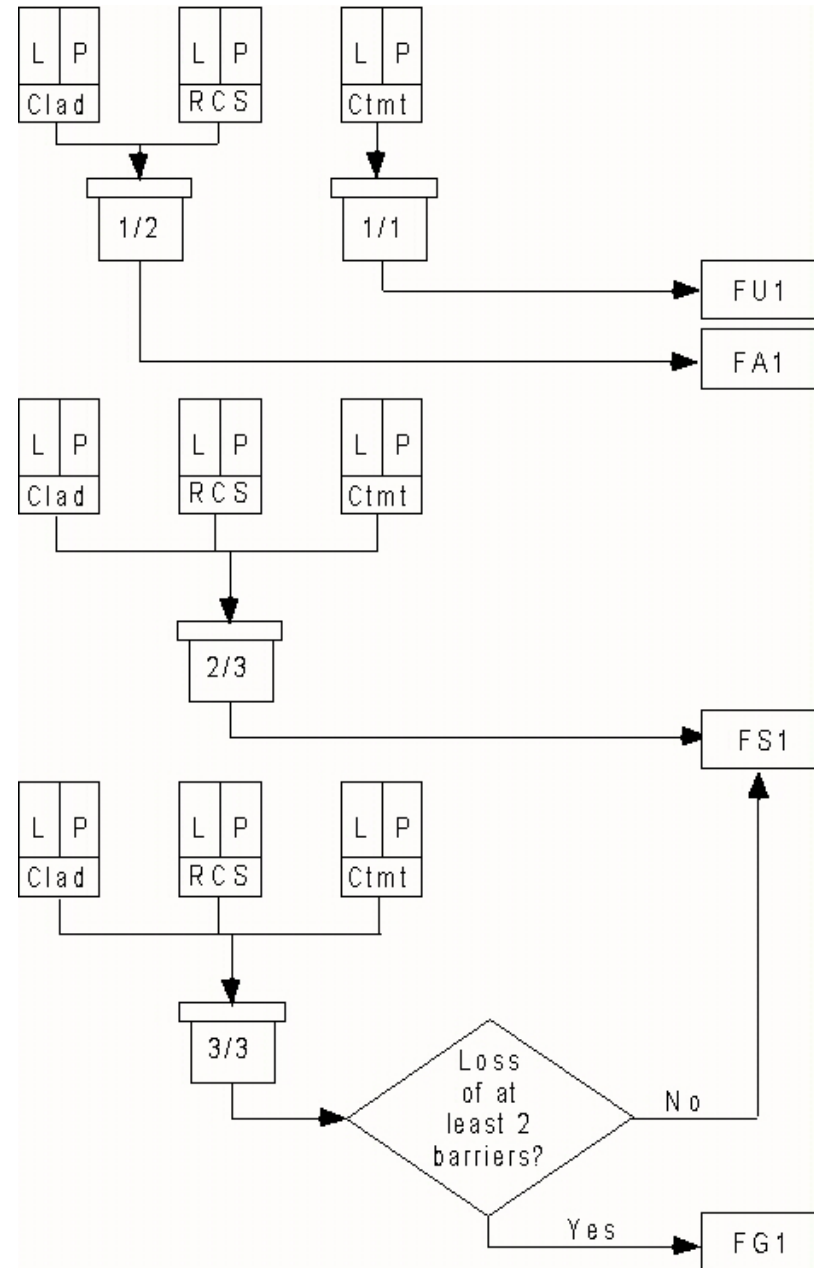

NOTES

The logic used for these initiating conditions reflects the following considerations:

- The Fuel Clad Barrier and the RCS Barrier are weighted more heavily than the Containment Barrier (See Sections 3.4 and 3.8). NOUE ICs associated with RCS and Fuel Clad Barriers are addressed under System Malfunction ICs.
- At the Site Area Emergency level, there must be some ability to dynamically assess how far present conditions are from the threshold for a General Emergency. For example, if Fuel Clad and RCS Barrier “Loss” EALs existed, that, in addition to off-site dose assessments, would require continual assessments of radioactive inventory and containment integrity. Alternatively, if both Fuel Clad and RCS Barrier “Potential Loss” EALs existed, the Emergency Director would have more assurance that there was no immediate need to escalate to a General Emergency.
- The ability to escalate to higher emergency classification levels as an event deteriorates must be maintained. For example, RCS leakage steadily increasing would represent an increasing risk to public health and safety.
- The Containment Barrier should not be declared lost or potentially lost based on exceeding Technical Specification action statement criteria, unless there is an event in progress requiring mitigation by the Containment barrier. When no event is in progress (Loss or Potential Loss of either Fuel Clad and/or RCS) the Containment Barrier status is addressed by Technical Specifications.

Table 5-F-2: BWR EAL Fission Product Barrier Table
Thresholds for LOSS or POTENTIAL LOSS of Barriers*

*Determine which combination of the three barriers are lost or have a potential loss and use the following key to classify the event. Also, multiple events could occur which result in the conclusion that exceeding the loss or potential loss thresholds is IMMIDENT. In this IMMIDENT loss situation use judgment and classify as if the thresholds are exceeded.

GENERAL EMERGENCY Loss of ANY two barriers AND Loss or Potential Loss of third barrier.	SITE AREA EMERGENCY Loss or Potential Loss of ANY two barriers.	ALERT ANY Loss or ANY Potential Loss of EITHER Fuel Clad or RCS.	UNUSUAL EVENT ANY Loss or ANY Potential Loss of Containment.
---	---	--	--

<u>Fuel Clad Barrier</u>		<u>RCS Barrier</u>		<u>Containment Barrier</u>	
LOSS	POTENTIAL LOSS	LOSS	POTENTIAL LOSS	LOSS	POTENTIAL LOSS
1. Primary Coolant Activity Level		1. Primary Containment Pressure		1. Primary Containment Conditions	
A. Primary coolant activity greater than (site specific value).	Not Applicable	A. Primary containment pressure greater than (site specific value) due to RCS leakage.	Not Applicable	A. Primary containment pressure rise followed by a rapid unexplained drop in primary containment pressure. OR B. Primary containment pressure response not consistent with LOCA conditions.	A. Primary containment pressure greater than (site specific value) and rising. OR B. Explosive mixture exists inside primary containment. OR C. RPV pressure and suppression pool temperature cannot be maintained below the HCTL.
2. Reactor Vessel Water Level		2. Reactor Vessel Water Level		2. Reactor Vessel Water Level	
A. RPV water level cannot be restored and maintained above (site specific RPV water level corresponding to the requirement for primary containment flooding).	A. RPV water level cannot be restored and maintained above (site specific RPV water level corresponding to the top of active fuel) or cannot be determined.	A. RPV water level cannot be restored and maintained above (site specific RPV water level corresponding to the top of active fuel) or cannot be determined.	Not Applicable	Not Applicable	A. Primary containment flooding required.

Table 5-F-2: BWR EAL Fission Product Barrier Table

Thresholds for LOSS or POTENTIAL LOSS of Barriers*

*Determine which combination of the three barriers are lost or have a potential loss and use the following key to classify the event. Also, multiple events could occur which result in the conclusion that exceeding the loss or potential loss thresholds is IMMIDENT. In this IMMIDENT loss situation use judgment and classify as if the thresholds are exceeded.

GENERAL EMERGENCY	SITE AREA EMERGENCY	ALERT	UNUSUAL EVENT
Loss of ANY two barriers AND Loss or Potential Loss of third barrier.	Loss or Potential Loss of ANY two barriers.	ANY Loss or ANY Potential Loss of EITHER Fuel Clad or RCS.	ANY Loss or ANY Potential Loss of Containment.

<u>Fuel Clad Barrier</u>		<u>RCS Barrier</u>		<u>Containment Barrier</u>	
LOSS	POTENTIAL LOSS	LOSS	POTENTIAL LOSS	LOSS	POTENTIAL LOSS
3. Not Applicable		3. RCS Leak Rate		3. Primary Containment Isolation Failure or Bypass	
Not Applicable	Not Applicable	A. (site specific Indication of an UNISOLABLE Main Steamline, HPCI, Feedwater, RWCU, or RCIC break) OR B. Emergency RPV Depressurization is required.	A. RCS leakage greater than 50 gpm inside the drywell. OR B. UNISOLABLE primary system leakage outside primary containment as indicated by exceeding EITHER of the following: a. Max Normal Operating Temperature. OR b. Max Normal Area Radiation.	A. Failure of all valves in any one line to close. AND Direct downstream pathway to the environment exists after primary containment isolation signal. OR B. Intentional primary containment venting per EOPs. OR C. UNISOLABLE primary system leakage outside primary containment as indicated by exceeding EITHER of the following: a. Max Safe Operating Temperature. OR b. Max Safe Area Radiation.	Not Applicable

Table 5-F-2: BWR EAL Fission Product Barrier Table

Thresholds for LOSS or POTENTIAL LOSS of Barriers*

*Determine which combination of the three barriers are lost or have a potential loss and use the following key to classify the event. Also, multiple events could occur which result in the conclusion that exceeding the loss or potential loss thresholds is IMMIDENT. In this IMMIDENT loss situation use judgment and classify as if the thresholds are exceeded.

GENERAL EMERGENCY Loss of ANY two barriers AND Loss or Potential Loss of third barrier.	SITE AREA EMERGENCY Loss or Potential Loss of ANY two barriers.	ALERT ANY Loss or ANY Potential Loss of EITHER Fuel Clad or RCS.	UNUSUAL EVENT ANY Loss or ANY Potential Loss of Containment.
---	---	--	--

<u>Fuel Clad Barrier</u>		<u>RCS Barrier</u>		<u>Containment Barrier</u>	
LOSS	POTENTIAL LOSS	LOSS	POTENTIAL LOSS	LOSS	POTENTIAL LOSS
4. Primary Containment Radiation Monitoring		4. Primary Containment Radiation Monitoring		4. Primary Containment Radiation Monitoring	
A. Primary containment radiation monitor reading greater than (site specific value).	Not Applicable	A. Primary containment radiation monitor reading greater than (site specific value).	Not Applicable	Not Applicable	A. Primary containment radiation monitor reading greater than (site specific value).
5. Other Site Specific Indications		5. Other Site Specific Indications		5. Other Site Specific Indications	
A. (site specific) as applicable.	A. (site specific) as applicable.	A. (site specific) as applicable.	A. (site specific) as applicable.	A. (site specific) as applicable.	A. (site specific) as applicable.
6. Emergency Director Judgment		6. Emergency Director Judgment		6. Emergency Director Judgment	
A. Any condition in the opinion of the Emergency Director that indicates Loss of the Fuel Clad Barrier.	A. Any condition in the opinion of the Emergency Director that indicates Potential Loss of the Fuel Clad Barrier.	A. Any condition in the opinion of the Emergency Director that indicates Loss of the RCS Barrier.	A. Any condition in the opinion of the Emergency Director that indicates Potential Loss of the RCS Barrier.	A. Any condition in the opinion of the Emergency Director that indicates Loss of the Containment Barrier.	A. Any condition in the opinion of the Emergency Director that indicates Potential Loss of the Containment Barrier.

Basis Information For BWR EAL Fission Product Barrier Table 5-F-2

FUEL CLAD BARRIER THRESHOLDS: (1 or 2 or 4 or 5 or 6)

The Fuel Clad barrier consists of the zircalloy or stainless steel fuel bundle tubes that contain the fuel pellets.

1. Primary Coolant Activity Level

The site specific value corresponds to 300 $\mu\text{Ci/gm}$ I-131 equivalent. Assessment by the EAL Task Force indicates that this amount of coolant activity is well above that expected for iodine spikes and corresponds to less than 5% fuel clad damage. This amount of radioactivity indicates significant clad damage and thus the Fuel Clad Barrier is considered lost.

[The value can be expressed either in mR/hr observed on the sample or as $\mu\text{Ci/gm}$ results from analysis.]

There is no Potential Loss threshold associated with this item.

2. Reactor Vessel Water Level

Loss Threshold A

This site specific value corresponds to the level used in EOPs to indicate challenge of core cooling. This is the minimum value to assure core cooling without further degradation of the clad.

[Depending on the plant this may be the Minimum Steam Cooling RPV Water Level or the jet pump suction without the requisite Core Spray cooling flow. BWROG EPGs/SAGs provide explicit direction when RPV water level cannot be determined. Since the loss of ability to determine if adequate core cooling is being provided presents a significant challenge to the fuel clad barrier, a potential loss of the fuel clad barrier is specified.]

Potential Loss Threshold A

This threshold is the same as the RCS barrier Loss threshold A and corresponds to the site specific water level at the top of the active fuel. Thus, this threshold indicates a Potential Loss of the Fuel Clad barrier and a Loss of RCS barrier that appropriately escalates the emergency classification level to a Site Area Emergency.

3. Not Applicable (included for numbering consistency between barrier tables)

4. Primary Containment Radiation Monitoring

The site specific reading is a value which indicates the release of reactor coolant, with elevated activity indicative of fuel damage, into the drywell.

[The reading should be calculated assuming the instantaneous release and dispersal of the reactor coolant noble gas and iodine inventory associated with a concentration of 300 $\mu\text{Ci/gm}$ dose equivalent I-131 or the calculated concentration equivalent to the clad damage used in threshold 1 into the drywell atmosphere.]

Basis Information For BWR EAL Fission Product Barrier Table 5-F-2

Reactor coolant concentrations of this magnitude are several times larger than the maximum concentrations (including iodine spiking) allowed within technical specifications and are therefore indicative of fuel damage.

This value is higher than that specified for RCS barrier Loss threshold #4. Thus, this threshold indicates a loss of both Fuel Clad barrier and RCS barrier that appropriately escalates the emergency classification level to a Site Area Emergency.

[Caution: it is important to recognize that in the event the radiation monitor is sensitive to shine from the reactor vessel or piping, spurious readings will be present and another indicator of fuel clad damage is necessary or compensated for in the threshold value.]

There is no Potential Loss threshold associated with this item.

5. Other Site Specific Indications

This subcategory addresses other site specific thresholds that may be included to indicate loss or potential loss of the Fuel Clad barrier.

6. Emergency Director Judgment

These thresholds address any other factors that are to be used by the Emergency Director in determining whether the Fuel Clad barrier is lost or potentially lost. In addition, the inability to monitor the barrier should also be incorporated in this threshold as a factor in Emergency Director judgment that the barrier may be considered lost or potentially lost.

Basis Information For BWR EAL Fission Product Barrier Table 5-F-2

RCS BARRIER THRESHOLDS: (1 or 2 or 3 or 4 or 5 or 6)

The RCS Barrier is the reactor coolant system pressure boundary and includes the reactor vessel and all reactor coolant system piping up to the isolation valves.

1. Primary Containment Conditions

The site specific primary containment pressure is based on the drywell high pressure set point which indicates a LOCA by automatically initiating the ECCS or equivalent makeup system.

There is no Potential Loss threshold associated with this item.

2. Reactor Vessel Water Level

The Loss threshold site specific RPV water level corresponds to the level that is used in EOPs to indicate challenge of core cooling.

This threshold is the same as Fuel Clad Barrier Potential Loss threshold #2.A and corresponds to a challenge to core cooling. Thus, this threshold indicates a Loss of RCS barrier and Potential Loss of Fuel Clad barrier that appropriately escalates the emergency classification level to a Site Area Emergency.

There is no Potential Loss threshold associated with this item.

3. RCS Leak Rate

Loss Threshold #A

An UNISOLABLE MSL break is a breach of the RCS barrier. Thus, this threshold is included for consistency with the Alert emergency classification level.

Other large high-energy line breaks such as HPCI, Feedwater, RWCU, or RCIC that are UNISOLABLE also represent a significant loss of the RCS barrier and should be considered as MSL breaks for purposes of classification.

Loss Threshold #B

Plant symptoms requiring Emergency RPV Depressurization per the site specific EOPs are indicative of a loss of the RCS barrier. If Emergency RPV depressurization is required, the plant operators are directed to open safety relief valves (SRVs) and keep them open. Even though the RCS is being vented into the suppression pool, a loss of the RCS should be considered to exist due to the diminished effectiveness of the RCS pressure barrier to a release of fission products beyond its boundary.

Potential Loss Threshold #A

This threshold is based on leakage is set at a level indicative of a small breach of the RCS but which is well within the makeup capability of normal and emergency high pressure systems. Core uncover is not a significant concern for a 50 gpm leak, however, break propagation leading to significantly larger loss of inventory is possible.

Basis Information For BWR EAL Fission Product Barrier Table 5-F-2

[Many BWRs may be unable to measure an RCS leak of this size because the leak would likely increase drywell pressure above the drywell isolation set point. The system normally used to monitor leakage is typically isolated as part of the drywell isolation and is therefore unavailable.]

If primary system leak rate information is unavailable, other indicators of RCS leakage should be used.

Potential Loss Threshold B

Potential loss of RCS based on primary system leakage outside the primary containment is determined from site specific temperature or area radiation Max Normal setpoints in the areas of the main steam line tunnel, main turbine generator, RCIC, HPCI, etc., which indicate a direct path from the RCS to areas outside primary containment.

The indicators reaching the threshold barriers and confirmed to be caused by RCS leakage warrant an Alert classification. An unisolable leak which is indicated by a high alarm setpoint escalates to a Site Area Emergency when combined with Containment Barrier Loss threshold 3.A (after a containment isolation) and a General Emergency when the Fuel Clad Barrier criteria is also exceeded.

4. Primary Containment Radiation Monitoring

The site specific reading is a value which indicates the release of reactor coolant to the primary containment.

[The reading should be calculated assuming the instantaneous release and dispersal of the reactor coolant noble gas and iodine inventory associated with normal operating concentrations (i.e., within T/S) into the drywell atmosphere.]

This reading will be less than that specified for Fuel Clad barrier Loss threshold #4. Thus, this threshold would be indicative of a RCS leak only. If the radiation monitor reading increased to that value specified by Fuel Clad Barrier threshold, fuel damage would also be indicated.

[However, if the site specific physical location of the primary containment radiation monitor is such that radiation from a cloud of released RCS gases could not be distinguished from radiation from adjacent piping and components containing elevated reactor coolant activity, this threshold should be omitted and other site specific indications of RCS leakage substituted.]

There is no Potential Loss threshold associated with this item.

5. Other Site Specific Indications

This subcategory addresses other site specific thresholds that may be included to indicate loss or potential loss of the RCS barrier.

6. Emergency Director Judgment

These thresholds address any other factors that are to be used by the Emergency Director in determining whether the RCS barrier is lost or potentially lost. In addition, the inability to monitor the barrier should also be incorporated in this threshold as a factor in Emergency Director judgment that the barrier may be considered lost or potentially lost.

Basis Information For BWR EAL Fission Product Barrier Table 5-F-2

CONTAINMENT BARRIER THRESHOLDS: (1 or 2 or 3 or 4 or 5 or 6)

The Primary Containment Barrier includes the drywell, the wetwell, their respective interconnecting paths, and other connections up to and including the outermost containment isolation valves. Containment Barrier thresholds are used primarily as discriminators for escalation from an Alert to a Site Area Emergency or a General Emergency.

1. Primary Containment Conditions

Loss Thresholds A and B

Rapid unexplained loss of pressure (i.e., not attributable to drywell spray or condensation effects) following an initial pressure increase from a high energy line break indicates a loss of containment integrity. Primary containment pressure should increase as a result of mass and energy release into containment from a LOCA. Thus, primary containment pressure not increasing under these conditions indicates a loss of containment integrity.

This indicator relies on operator recognition of an unexpected response for the condition and therefore does not have a specific value associated with it. The unexpected response is important because it is the indicator for a containment bypass condition.

Potential Loss Threshold A

The site specific pressure is based on the primary containment design pressure.

Potential Loss Threshold B

[BWRs specifically define the limits associated with explosive mixtures in terms of deflagration concentrations of hydrogen and oxygen. For Mk I/II containments the deflagration limits are "6% hydrogen and 5% oxygen in the drywell or suppression chamber". For Mk III containments, the limit is the "Hydrogen Deflagration Overpressure Limit". The term "explosive mixture" is synonymous with "deflagration limits" and is used as it is a more easily understood term.]

Potential Loss Threshold C

The Heat Capacity Temperature Limit (HCTL) is the highest suppression pool temperature from which Emergency RPV Depressurization will not raise:

- Suppression chamber temperature above the maximum temperature capability of the suppression chamber and equipment within the suppression chamber which may be required to operate when the RPV is pressurized,

OR

- Suppression chamber pressure above Primary Containment Pressure Limit A, while the rate of energy transfer from the RPV to the containment is greater than the capacity of the containment vent.

The HCTL is a function of RPV pressure and suppression pool water level. It is utilized to preclude failure of the containment and equipment in the containment necessary for the safe shutdown of the plant and therefore, the inability to maintain plant parameters below the limit constitutes a potential loss of containment.

Basis Information For BWR EAL Fission Product Barrier Table 5-F-2

2. Reactor Vessel Water Level

There is no Loss threshold associated with this item.

The potential loss requirement for Primary Containment Flooding indicates adequate core cooling cannot be established and maintained and that core melt is possible. Entry into Primary Containment Flooding procedures is a logical escalation in response to the inability to maintain adequate core cooling.

[Severe Accident Guidelines (SAGs) direct the operators to perform Containment Flooding when Reactor Vessel Level cannot be restored and maintained greater than a site specific value or RPV level cannot be determined with indication that core damage is occurring.]

The condition in this potential loss threshold represents a potential core melt sequence which, if not corrected, could lead to vessel failure and increased potential for containment failure. In conjunction with Reactor Vessel water level "Loss" thresholds in the Fuel Clad and RCS barrier columns, this threshold will result in the declaration of a General Emergency -- loss of two barriers and the potential loss of a third.

3. Primary Containment Isolation Failure or Bypass

These thresholds address incomplete containment isolation that allows direct release to the environment.

Loss Threshold A

The use of the modifier "direct" in defining the release path discriminates against release paths through interfacing liquid systems. The existence of an in-line charcoal filter does not make a release path indirect since the filter is not effective at removing fission product noble gases. Typical filters have an efficiency of 95-99% removal of iodine. Given the magnitude of the core inventory of iodine, significant releases could still occur. In addition, since the fission product release would be driven by boiling in the reactor vessel, the high humidity in the release stream can be expected to render the filters ineffective in a short period.

Loss Threshold B

Site specific EOPs may direct containment isolation valve logic(s) to be intentionally bypassed, regardless of radioactivity release rates. Under these conditions with a valid containment isolation signal, the containment should also be considered lost if containment venting is actually performed.

Intentional venting of primary containment for primary containment pressure or combustible gas control per EOPs to the secondary containment and/or the environment is considered a loss of containment. Containment venting for pressure when not in an accident situation should not be considered.

Loss Threshold C

In addition, the presence of area radiation or temperature Max Safe Operating setpoints indicating unisolable primary system leakage outside the primary containment are addressed after a containment isolation. The indicators should be confirmed to be caused by RCS leakage.

Basis Information For BWR EAL Fission Product Barrier Table 5-F-2

There is no Potential Loss threshold associated with this item.

4. Primary Containment Radiation Monitoring

The site specific reading is a value that indicates significant fuel damage well in excess of that required for loss of RCS and Fuel Clad.

[As stated in Section 3.8, a major release of radioactivity requiring off-site protective actions from core damage is not possible unless a major failure of fuel cladding allows radioactive material to be released from the core into the reactor coolant.]

Regardless of whether containment is challenged, this amount of activity in containment, if released, could have such severe consequences that it is prudent to treat this as a potential loss of containment, such that a General Emergency declaration is warranted.

[NUREG-1228, "Source Estimations During Incident Response to Severe Nuclear Power Plant Accidents," indicates that such conditions do not exist when the amount of clad damage is less than 20%. Unless there is a (site specific) analysis justifying a higher value, it is recommended that a radiation monitor reading corresponding to 20% fuel clad damage be specified here.]

There is no Loss threshold associated with this item.

5. Other Site Specific Indications

This subcategory addresses other site specific thresholds that may be included to indicate loss or potential loss of the Containment barrier.

6. Emergency Director Judgment

These thresholds address any other factors that are to be used by the Emergency Director in determining whether the Containment barrier is lost or potentially lost. In addition, the inability to monitor the barrier should also be incorporated in this threshold as a factor in Emergency Director judgment that the barrier may be considered lost or potentially lost.

The Containment barrier should not be declared lost or potentially lost based on exceeding Technical Specification action statement criteria, unless there is an event in progress requiring mitigation by the Containment barrier. When no event is in progress (Loss or Potential Loss of either Fuel Clad and/or RCS) the Containment barrier status is addressed by Technical Specifications.

Table 5-F-3: PWR EAL Fission Product Barrier Table

Thresholds for LOSS or POTENTIAL LOSS of Barriers*

*Determine which combination of the three barriers are lost or have a potential loss and use the following key to classify the event. Also, multiple events could occur which result in the conclusion that exceeding the loss or potential loss thresholds is IMMIDENT. In this IMMIDENT loss situation use judgment and classify as if the thresholds are exceeded.

GENERAL EMERGENCY	SITE AREA EMERGENCY	ALERT	UNUSUAL EVENT
Loss of ANY two barriers AND Loss or Potential Loss of third barrier.	Loss or Potential Loss of ANY two barriers.	ANY Loss or ANY Potential Loss of EITHER Fuel Clad or RCS.	ANY Loss or ANY Potential Loss of Containment.

Fuel Clad Barrier Thresholds		RCS Barrier Thresholds		Containment Barrier Thresholds	
LOSS	POTENTIAL LOSS	LOSS	POTENTIAL LOSS	LOSS	POTENTIAL LOSS
1. Critical Safety Function Status		1. Critical Safety Function Status		1. Critical Safety Function Status	
A. Core-Cooling Red Entry Conditions Met.	A. Core Cooling-Orange Entry Conditions Met. OR B. Heat Sink-Red Entry Conditions Met.	Not Applicable	A. RCS Integrity-Red Entry Conditions Met. OR B. Heat Sink-Red Entry Conditions Met.	Not Applicable	A. Containment-Red Entry Conditions Met.
2. Primary Coolant Activity Level		2. RCS Leak Rate		2. Containment Pressure	
A. Coolant activity greater than (site specific value).	Not Applicable	A. RCS leak rate greater than available makeup capacity as indicated by a loss of RCS subcooling.	A. RCS leak rate indicated greater than (site specific capacity of one charging pump in the normal charging mode) with Letdown isolated.	A. A containment pressure rise followed by a rapid unexplained drop in containment pressure. OR B. Containment pressure or sump level response not consistent with LOCA conditions.	A. Containment pressure greater than (site specific value) and rising. OR B. Explosive mixture exists inside containment. OR C. a. Pressure greater than containment depressurization actuation setpoint. AND b. Less than one full train of depressurization equipment operating.

Table 5-F-3: PWR EAL Fission Product Barrier Table
Thresholds for LOSS or POTENTIAL LOSS of Barriers*

*Determine which combination of the three barriers are lost or have a potential loss and use the following key to classify the event. Also, multiple events could occur which result in the conclusion that exceeding the loss or potential loss thresholds is IMMIDENT. In this IMMIDENT loss situation use judgment and classify as if the thresholds are exceeded.

GENERAL EMERGENCY	SITE AREA EMERGENCY	ALERT	UNUSUAL EVENT
Loss of ANY two barriers AND Loss or Potential Loss of third barrier.	Loss or Potential Loss of ANY two barriers.	ANY Loss or ANY Potential Loss of EITHER Fuel Clad or RCS.	ANY Loss or ANY Potential Loss of Containment.

Fuel Clad Barrier Thresholds		RCS Barrier Thresholds		Containment Barrier Thresholds	
LOSS	POTENTIAL LOSS	LOSS	POTENTIAL LOSS	LOSS	POTENTIAL LOSS
3. Core Exit Thermocouple Readings		3. Not Applicable		3. Core Exit Thermocouple Readings	
A. Core exit thermocouples reading greater than (site specific degree F).	A.. Core exit thermocouples reading greater than (site specific degree F).	Not Applicable	Not Applicable	Not Applicable	A. a. Core exit thermocouples in excess of (site specific) ° F. AND b. Restoration procedures not effective within 15 minutes. OR B. a Core exit thermocouples in excess of (site-specific) F. AND b. Reactor vessel level below (site specific level). AND c. Restoration procedures not effective within 15 minutes.

Table 5-F-3: PWR EAL Fission Product Barrier Table

Thresholds for LOSS or POTENTIAL LOSS of Barriers*

*Determine which combination of the three barriers are lost or have a potential loss and use the following key to classify the event. Also, multiple events could occur which result in the conclusion that exceeding the loss or potential loss thresholds is IMMIDENT. In this IMMIDENT loss situation use judgment and classify as if the thresholds are exceeded.

GENERAL EMERGENCY	SITE AREA EMERGENCY	ALERT	UNUSUAL EVENT
Loss of ANY two barriers AND Loss or Potential Loss of third barrier.	Loss or Potential Loss of ANY two barriers.	ANY Loss or ANY Potential Loss of EITHER Fuel Clad or RCS.	ANY Loss or ANY Potential Loss of Containment.

Fuel Clad Barrier Thresholds		RCS Barrier Thresholds		Containment Barrier Thresholds	
LOSS	POTENTIAL LOSS	LOSS	POTENTIAL LOSS	LOSS	POTENTIAL LOSS
4. Reactor Vessel Water Level		4. SG Tube Rupture		4. SG Secondary Side Release with P-to-S Leakage	
Not Applicable	A. RCS/RPV level less than (site specific level for TOAF).	A. RUPTURED SG results in an ECCS (SI) actuation.	Not Applicable	A. RUPTURED SG is also FAULTED outside of containment. OR B. a. Primary-to-Secondary leakrate greater than 10 gpm. AND b. UNISOLABLE steam release from affected SG to the environment.	Not Applicable
5. Not Applicable		5. Not Applicable		5. Containment Isolation Failure or Bypass	
Not Applicable	Not Applicable	Not Applicable	Not Applicable	A. a. Failure of all valves in any one line to close AND b. Direct downstream pathway to the environment exists after containment isolation signal.	Not Applicable

Table 5-F-3: PWR EAL Fission Product Barrier Table

Thresholds for LOSS or POTENTIAL LOSS of Barriers*

*Determine which combination of the three barriers are lost or have a potential loss and use the following key to classify the event. Also, multiple events could occur which result in the conclusion that exceeding the loss or potential loss thresholds is IMMEDIATE. In this IMMEDIATE loss situation use judgment and classify as if the thresholds are exceeded.

GENERAL EMERGENCY	SITE AREA EMERGENCY	ALERT	UNUSUAL EVENT
Loss of ANY two barriers AND Loss or Potential Loss of third barrier.	Loss or Potential Loss of ANY two barriers.	ANY Loss or ANY Potential Loss of EITHER Fuel Clad or RCS.	ANY Loss or ANY Potential Loss of Containment.

Fuel Clad Barrier Thresholds		RCS Barrier Thresholds		Containment Barrier Thresholds	
LOSS	POTENTIAL LOSS	LOSS	POTENTIAL LOSS	LOSS	POTENTIAL LOSS
6. Containment Radiation Monitoring		6. Containment Radiation Monitoring		6. Containment Radiation Monitoring	
A. Containment radiation monitor reading greater than (site specific value).	Not Applicable	A. Containment radiation monitor reading greater than (site specific value).	Not Applicable	Not Applicable	A. Containment radiation monitor reading greater than (site specific value).
7. Other Site Specific Indications		7. Other Site Specific Indications		7. Other Site Specific Indications	
A. (site specific) as applicable.	A. (site specific) as applicable.	A. (site specific) as applicable.	A. (site specific) as applicable.	A. (site specific) as applicable.	A. (site specific) as applicable.
8. Emergency Director Judgment		8. Emergency Director Judgment		8. Emergency Director Judgment	
A. Any condition in the opinion of the Emergency Director that indicates Loss of the Fuel Clad Barrier.	A. Any condition in the opinion of the Emergency Director that indicates Potential Loss of the Fuel Clad Barrier.	A. Any condition in the opinion of the Emergency Director that indicates Loss of the RCS Barrier.	A. Any condition in the opinion of the Emergency Director that indicates Potential Loss of the RCS Barrier.	A. Any condition in the opinion of the Emergency Director that indicates Loss of the Containment Barrier.	A. Any condition in the opinion of the Emergency Director that indicates Potential Loss of the Containment Barrier.

Basis Information For PWR EAL Fission Product Barrier Table 5-F-3

FUEL CLAD BARRIER THRESHOLDS: (1 or 2 or 3 or 4 or 6 or 7 or 8)

The Fuel Clad barrier consists of the zircalloy or stainless steel fuel bundle tubes that contain the fuel pellets.

1. Critical Safety Function Status

[These thresholds are for PWRs using Critical Safety Function Status Tree (CSFST) monitoring and functional restoration procedures. For more information, please refer to Section 3.9 of this document.]

Loss Threshold A

Core Cooling - RED indicates significant superheating and core uncovering and is considered to indicate loss of the Fuel Clad Barrier.

Potential Loss Threshold A

Core Cooling - ORANGE indicates subcooling has been lost and that some clad damage may occur.

Potential Loss Threshold B

Heat Sink - RED when heat sink is required indicates the ultimate heat sink function is under extreme challenge.

2. Primary Coolant Activity Level

The site specific value corresponds to 300 $\mu\text{Ci/gm}$ I-131 equivalent. Assessment by the EAL Task Force indicates that this amount of coolant activity is well above that expected for iodine spikes and corresponds to less than 5% fuel clad damage. This amount of radioactivity indicates significant clad damage and thus the Fuel Clad Barrier is considered lost.

[The value can be expressed either in mR/hr observed on the sample or as $\mu\text{Ci/gm}$ results from analysis.]

There is no Potential Loss threshold associated with this item.

3. Core Exit Thermocouple Readings

[Core Exit Thermocouple Readings are included in addition to the Critical Safety Functions to include conditions when the CSFs may not be in use (initiation after SI is blocked) or plants which do not have a CSF scheme.]

Loss Threshold A

The site specific reading should correspond to significant superheating of the coolant.

[This value typically corresponds to the temperature reading that indicates core cooling - RED in Fuel Clad Barrier loss threshold 1.A which is usually about 1200 degrees F.]

Basis Information For PWR EAL Fission Product Barrier Table 5-F-3

Potential Loss Threshold A

The site specific reading should correspond to loss of subcooling.

[This value typically corresponds to the temperature reading that indicates core cooling - ORANGE in Fuel Clad Barrier potential loss threshold 1.A which is usually about 700 to 900 degrees F.]

4. Reactor Vessel Water Level

There is no Loss threshold associated with this item.

The site specific value for the Potential Loss threshold corresponds to the top of the active fuel.

[For sites using CSFSTs, the Potential Loss threshold is defined by the Core Cooling - ORANGE path. The site specific value in this threshold should be consistent with the CSFST value.]

5. Not Applicable (included for numbering consistency between barrier tables)

6. Containment Radiation Monitoring

The site specific reading is a value which indicates the release of reactor coolant, with elevated activity indicative of fuel damage, into the containment.

[The reading should be calculated assuming the instantaneous release and dispersal of the reactor coolant noble gas and iodine inventory associated with a concentration of 300 $\mu\text{Ci/gm}$ dose equivalent I-131 into the containment atmosphere.]

Reactor coolant concentrations of this magnitude are several times larger than the maximum concentrations (including iodine spiking) allowed within technical specifications and are therefore indicative of fuel damage.

This value is higher than that specified for RCS barrier Loss threshold #6. Thus, this threshold indicates a loss of both the Fuel Clad barrier and RCS barrier that appropriately escalates the emergency classification level to a Site Area Emergency.

[Caution: *it is important to recognize that in the event the radiation monitor is sensitive to shine from the reactor vessel or piping, spurious readings will be present and another indicator of fuel clad damage is necessary or compensated for in the threshold value.*]

There is no Potential Loss threshold associated with this item.

7. Other Site Specific Indications

This subcategory addresses other site specific thresholds that may be included to indicate loss or potential loss of the Fuel Clad barrier.

**Basis Information For
PWR EAL Fission Product Barrier Table 5-F-3**

8. Emergency Director Judgment

These thresholds address any other factors that are to be used by the Emergency Director in determining whether the Fuel Clad barrier is lost or potentially lost. In addition, the inability to monitor the barrier should also be incorporated in this threshold as a factor in Emergency Director judgment that the barrier may be considered lost or potentially lost.

Basis Information For PWR EAL Fission Product Barrier Table 5-F-3

RCS BARRIER THRESHOLDS: (1 or 2 or 4 or 6 or 7 or 8)

The RCS Barrier includes the RCS primary side and its connections up to and including the pressurizer safety and relief valves, and other connections up to and including the primary isolation valves.

1. Critical Safety Function Status

[These thresholds are for PWRs using Critical Safety Function Status Tree (CSFST) monitoring and functional restoration procedures. For more information, refer to Section 3.9 of this report.]

Potential Loss Threshold A

RCS Integrity - RED indicates an extreme challenge to the safety function derived from appropriate instrument readings.

Potential Loss Threshold B

Heat Sink - RED when heat sink is required indicates the ultimate heat sink function is under extreme challenge.

There is no Loss threshold associated with this item.

2. RCS Leak Rate

Loss Threshold A

This threshold addresses conditions where leakage from the RCS is greater than available inventory control capacity such that a loss of subcooling has occurred. The loss of subcooling is the fundamental indication that the inventory control systems are inadequate in maintaining RCS pressure and inventory against the mass loss through the leak.

Potential Loss Threshold A

This threshold is based on the apparent inability to maintain normal liquid inventory within the Reactor Coolant System (RCS) by normal operation of the Chemical and Volume Control System which is considered to be the flow rate equivalent to one charging pump discharging to the charging header. Isolating letdown is a standard abnormal operating procedure action and may prevent unnecessary classifications when a non-RCS leakage path such as a CVCS leak exists. The intent of this condition is met if attempts to isolate Letdown are NOT successful. Additional charging pumps being required is indicative of a substantial RCS leak.

[For plants with low capacity charging pumps, a 50 gpm indicated leak rate value may be used to indicate the Potential Loss.]

3. Not Applicable (included for numbering consistency between barrier tables)

Basis Information For PWR EAL Fission Product Barrier Table 5-F-3

4. SG Tube Rupture

This threshold addresses the full spectrum of Steam Generator (SG) tube rupture events in conjunction with Containment barrier Loss thresholds. It addresses RUPTURED SG(s) for which the leakage is large enough to cause actuation of ECCS (SI). This is consistent to the RCS leak rate barrier Potential Loss threshold.

[For plants that have implemented Westinghouse Owners Group emergency response guides, this condition is described by "entry into E-3 required by EOPs".]

By itself, this threshold will result in the declaration of an Alert. However, if the SG is also FAULTED (i.e., two barriers failed), the declaration escalates to a Site Area Emergency per Containment barrier Loss thresholds.

There is no Potential Loss threshold associated with this item.

5. Not Applicable (included for numbering consistency between barrier tables)

6. Containment Radiation Monitoring

The site specific reading is a value which indicates the release of reactor coolant to the containment.

[The reading should be calculated assuming the instantaneous release and dispersal of the reactor coolant noble gas and iodine inventory associated with normal operating concentrations (i.e., within T/S) into the containment atmosphere.]

This reading will be less than that specified for Fuel Clad barrier threshold 6. Thus, this threshold would be indicative of a RCS leak only. If the radiation monitor reading increased to that specified by Fuel Clad barrier threshold, fuel damage would also be indicated.

[However, if the site specific physical location of the containment radiation monitor is such that radiation from a cloud of released RCS gases could not be distinguished from radiation from adjacent piping and components containing elevated reactor coolant activity, this threshold should be omitted and other site specific indications of RCS leakage substituted.]

There is no Potential Loss threshold associated with this item.

7. Other Site Specific Indications

This subcategory addresses other site specific thresholds that may be included to indicate loss or potential loss of the RCS barrier.

8. Emergency Director Judgment

These thresholds address any other factors that are to be used by the Emergency Director in determining whether the RCS barrier is lost or potentially lost. In addition, the inability to monitor the barrier should also be incorporated in this threshold as a factor in Emergency Director judgment that the barrier may be considered lost or potentially lost.

Basis Information For PWR EAL Fission Product Barrier Table 5-F-3

CONTAINMENT BARRIER THRESHOLDS: (1 or 2 or 3 or 4 or 5 or 6 or 7 or 8)

The Containment Barrier includes the containment building and connections up to and including the outermost containment isolation valves. This barrier also includes the main steam, feedwater, and blowdown line extensions outside the containment building up to and including the outermost secondary side isolation valve.

1. Critical Safety Function Status

[These thresholds are for PWRs using Critical Safety Function Status Tree (CSFST) monitoring and functional restoration procedures. For more information, refer to Section 3.9 of this report.]

RED path indicates an extreme challenge to the safety function derived from appropriate instrument readings and/or sampling results, and thus represents a potential loss of containment.

Conditions leading to a containment RED path result from RCS barrier and/or Fuel Clad Barrier Loss. Thus, this threshold is primarily a discriminator between Site Area Emergency and General Emergency representing a potential loss of the third barrier.

There is no Loss threshold associated with this item.

2. Containment Pressure

Loss Thresholds A and B

Rapid unexplained loss of pressure (i.e., not attributable to containment spray or condensation effects) following an initial pressure increase from a primary or secondary high energy line break indicates a loss of containment integrity. Containment pressure and sump levels should increase as a result of mass and energy release into containment from a LOCA. Thus, sump level or pressure not increasing indicates containment bypass and a loss of containment integrity.

This indicator relies on operator recognition of an unexpected response for the condition and therefore does not have a specific value associated with it. The unexpected response is important because it is the indicator for a containment bypass condition.

Potential Loss Threshold A

The site specific pressure is based on the containment design pressure.

Potential Loss Threshold B

Existence of an explosive mixture means a hydrogen and oxygen concentration of at least the lower deflagration limit curve exists. The indications of potential loss under this EAL corresponds to some of those leading to the RED path in potential loss threshold 1.A above and may be declared by those sites using CSFSTs.

Basis Information For PWR EAL Fission Product Barrier Table 5-F-3

Potential Loss Threshold C

This threshold represents a potential loss of containment in that the containment heat removal/depressurization system (e.g., containment sprays, ice condenser fans, etc., but not including containment venting strategies) are either lost or performing in a degraded manner, as indicated by containment pressure greater than the setpoint at which the equipment was supposed to have actuated.

3. Core Exit Thermocouple Readings

There is no Loss threshold associated with this item.

The conditions in these thresholds represent an IMMEDIATE core melt sequence which, if not corrected, could lead to vessel failure and an increased potential for containment failure. In conjunction with the Core Cooling and RCS Leakage criteria in the Fuel and RCS barrier columns, this threshold would result in the declaration of a General Emergency -- loss of two barriers and the potential loss of a third. If the function restoration procedures are ineffective, there is no "success" path.

The function restoration procedures are those emergency operating procedures that address the recovery of the core cooling critical safety functions. The procedure is considered effective if the temperature is decreasing or if the vessel water level is increasing.

[For units using the CSF status trees, a direct correlation to those status trees can be made if the effectiveness of the restoration procedures is also evaluated as stated below.]

[Severe accident analyses (e.g., NUREG-1150) have concluded that function restoration procedures can arrest core degradation within the reactor vessel in a significant fraction of the core damage scenarios, and that the likelihood of containment failure is very small in these events. Given this, it is appropriate to provide a reasonable period to allow function restoration procedures to arrest the core melt sequence.]

Whether or not the procedures will be effective should be apparent within 15 minutes. The Emergency Director should make the declaration as soon as it is determined that the procedures have been, or will be ineffective.

Potential Loss Threshold B

[The reactor vessel level chosen should be consistent with the emergency response guides applicable to the facility.]

4. SG Secondary Side Release With Primary to Secondary Leakage

The loss threshold recognizes that SG tube leakage can represent a bypass of the Containment barrier as well as a loss of the RCS barrier.

Users should realize that the two loss thresholds could be considered redundant. This was recognized during the development process. The inclusion of an threshold that uses Emergency Procedure commonly used terms like "RUPTURED and FAULTED" adds to the ease of the classification process and has been included based on this human factor concern.

Basis Information For PWR EAL Fission Product Barrier Table 5-F-3

This threshold results in a NOUE for smaller breaks that; (1) do not exceed the normal charging capacity threshold in RCS leak rate barrier Potential Loss threshold, or (2) do not result in ECCS actuation in RCS SG tube rupture barrier Loss threshold. For larger breaks, RCS barrier threshold criteria would result in an Alert. For SG tube ruptures which may involve multiple steam generators or unisolable secondary line breaks, this threshold would exist in conjunction with RCS barrier thresholds and would result in a Site Area Emergency. Escalation to General Emergency would be based on "Potential Loss" of the Fuel Clad Barrier.

Loss Threshold A

This threshold addresses the condition in which a RUPTURED steam generator is also FAULTED. This condition represents a bypass of the RCS and containment barriers and is a subset of the second threshold. In conjunction with RCS leak rate barrier loss threshold, this would always result in the declaration of a Site Area Emergency.

Loss Threshold B

This threshold addresses SG tube leaks that exceed 10 gpm in conjunction with an UNISOLABLE release path to the environment from the affected steam generator. The threshold for establishing the UNISOLABLE secondary side release is intended to be a prolonged release of radioactivity from the RUPTURED steam generator directly to the environment. This could be expected to occur when the main condenser is unavailable to accept the contaminated steam (i.e., SG tube rupture with concurrent loss of off-site power and the RUPTURED steam generator is required for plant cooldown or a stuck open relief valve). If the main condenser is available, there may be releases via air ejectors, gland seal exhausters, and other similar controlled, and often monitored, pathways. These pathways do not meet the intent of an UNISOLABLE release path to the environment. These minor releases are assessed using Abnormal Rad Levels / Radiological Effluent ICs.

[The leakage threshold for this threshold has been increased with Revision 3. In the earlier revision, the threshold was leakage greater than T/S allowable. Since the prior revision, many plants have implemented reduced steam generator T/S limits (e.g., 150 gpd) as a defense in depth associated with alternate steam generator plugging criteria. The 150 gpd threshold is deemed too low for use as an emergency threshold. A pressure boundary leakage of 10 gpm was used as the threshold in IC SU5, RCS Leakage, and is deemed appropriate for this threshold.]

5. Containment Isolation Failure or Bypass

This threshold addresses incomplete containment isolation that allows direct release to the environment.

The use of the modifier "direct" in defining the release path discriminates against release paths through interfacing liquid systems. The existence of an in-line charcoal filter does not make a release path indirect since the filter is not effective at removing fission product noble gases. Typical filters have an efficiency of 95-99% removal of iodine. Given the magnitude of the core inventory of iodine, significant releases could still occur. In addition, since the fission product release would be driven by boiling in the reactor vessel, the high humidity in the release stream can be expected to render the filters ineffective in a short period.

There is no Potential Loss threshold associated with this item.

Basis Information For PWR EAL Fission Product Barrier Table 5-F-3

6. Containment Radiation Monitoring

There is no Loss threshold associated with this item.

The site specific reading is a value which indicates significant fuel damage well in excess of the thresholds associated with both loss of Fuel Clad and loss of RCS barriers. As stated in Section 3.8, a major release of radioactivity requiring off-site protective actions from core damage is not possible unless a major failure of fuel cladding allows radioactive material to be released from the core into the reactor coolant.

Regardless of whether containment is challenged, this amount of activity in containment, if released, could have such severe consequences that it is prudent to treat this as a potential loss of containment, such that a General Emergency declaration is warranted.

[NUREG-1228, "Source Estimations During Incident Response to Severe Nuclear Power Plant Accidents," indicates that such conditions do not exist when the amount of clad damage is less than 20%. Unless there is a (site specific) analysis justifying a higher value, it is recommended that a radiation monitor reading corresponding to 20% fuel clad damage be specified here.]

7. Other Site Specific Indications

[This EAL should cover other (site-specific) indications that may unambiguously indicate loss or potential loss of the containment barrier, including indications from area or ventilation monitors in containment annulus or other contiguous buildings. If site emergency operating procedures provide for venting of the containment during an emergency as a means of preventing catastrophic failure, a Loss EAL should be included for the containment barrier. This EAL should be declared as soon as such venting is IMMINENT. Containment venting as part of recovery actions is classified in accordance with the radiological effluent ICs.]

8. Emergency Director Judgment

These thresholds address any other factors that are to be used by the Emergency Director in determining whether the Containment barrier is lost or potentially lost. In addition, the inability to monitor the barrier should also be incorporated in this threshold as a factor in Emergency Director judgment that the barrier may be considered lost or potentially lost.

The Containment barrier should not be declared lost or potentially lost based on exceeding Technical Specification action statement criteria, unless there is an event in progress requiring mitigation by the Containment barrier. When no event is in progress (Loss or Potential Loss of either Fuel Clad and/or RCS) the Containment barrier status is addressed by Technical Specifications.

5.10 HAZARDS AND OTHER CONDITIONS AFFECTING PLANT SAFETY EALs

Table 5-H-1: Recognition Category “H” Initiating Condition Matrix

GENERAL EMERGENCY	SITE AREA EMERGENCY	ALERT	UNUSUAL EVENT
<p>HG1 HOSTILE ACTION resulting in loss of physical control of the facility. <i>Op. Modes: All</i></p>	<p>HS2 Control room evacuation has been initiated and plant control cannot be established. <i>Op. Modes: All</i></p>	<p>HA1 Natural or destructive phenomena affecting VITAL AREAS. <i>Op. Modes: All</i></p> <p>HA2 FIRE or EXPLOSION affecting the operability of plant safety systems required to establish or maintain safe shutdown. <i>Op. Modes: All</i></p>	<p>HU1 Natural or destructive phenomena affecting the PROTECTED AREA. <i>Op. Modes: All</i></p> <p>HU2 FIRE within the PROTECTED AREA not extinguished in within 15 minutes of detection OR EXPLOSION within the PROTECTED AREA. <i>Op. Modes: All</i></p>
		<p>HA3 Access to a VITAL AREA is prohibited due to toxic, corrosive, asphyxiant or flammable gases which jeopardize operation of operable equipment required to maintain safe operations or safely shutdown the reactor. <i>Op. Modes: All</i></p>	<p>HU3 Release of toxic, corrosive, asphyxiant, or flammable gases deemed detrimental to NORMAL PLANT OPERATIONS. <i>Op. Modes: All</i></p>
		<p>HA5 Control room evacuation has been initiated. <i>Op. Modes: All</i></p>	
	<p>HS4 HOSTILE ACTION within the PROTECTED AREA. <i>Op. Modes: All</i></p>	<p>HA4 HOSTILE ACTION within the OWNER CONTROLLED AREA or airborne attack threat. <i>Op. Modes: All</i></p>	<p>HU4 Confirmed SECURITY CONDITION or threat which indicates a potential degradation in the level of safety of the plant. <i>Op. Modes: All</i></p>

Table 5-H-1: Recognition Category “H” Initiating Condition Matrix

GENERAL EMERGENCY	SITE AREA EMERGENCY	ALERT	UNUSUAL EVENT
HG2 Other conditions exist which in the judgment of the Emergency Director warrant declaration of a General Emergency. <i>Op. Modes: All</i>	HS3 Other conditions exist which in the judgment of the Emergency Director warrant declaration of a Site Area Emergency. <i>Op. Modes: All</i>	HA6 Other conditions exist which in the judgment of the Emergency Director warrant declaration of an Alert. <i>Op. Modes: All</i>	HU5 Other conditions exist which in the judgment of the Emergency Director warrant declaration of a NOUE. <i>Op. Modes: All</i>

HAZARDS AND OTHER CONDITIONS AFFECTING PLANT SAFETY

HU1

Initiating Condition - NOTIFICATION OF UNUSUAL EVENT

Natural or destructive phenomena affecting the PROTECTED AREA.

Operating Mode Applicability: All

Example Emergency Action Level: (1 or 2 or 3 or 4 or 5)

1. Seismic event identified by **ANY** 2 of the following:
 - Seismic event confirmed by (site specific indication or method)
 - Earthquake felt in plant
 - National Earthquake Center
2. Tornado striking within PROTECTED AREA boundary or high winds greater than (site specific mph).
3. Internal flooding that has the potential to affect safety related equipment required by Technical Specifications for the current operating mode in **ANY** of the following areas:
(site specific area list)
4. Turbine failure resulting in casing penetration or damage to turbine or generator seals.
5. (Site specific occurrences affecting the PROTECTED AREA).

Basis:

These EALs are categorized on the basis of the occurrence of an event of sufficient magnitude to be of concern to plant operators.

EAL #1

Damage may be caused to some portions of the site, but should not affect ability of safety functions to operate.

As defined in the EPRI-sponsored Guidelines for Nuclear Plant Response to an Earthquake, dated October 1989, a "felt earthquake" is: An earthquake of sufficient intensity such that: (a) the vibratory ground motion is felt at the nuclear plant site and recognized as an earthquake based on a consensus of control room operators on duty at the time, and (b) for plants with operable seismic instrumentation, the seismic switches of the plant are activated.

[For most plants with seismic instrumentation, the seismic switches are set at an acceleration of about 0.01g. This EAL should be developed on site specific basis. The method of detection can be based on instrumentation, validated by a reliable source, or operator assessment.]

The National Earthquake Center can confirm if an earthquake has occurred in the area of the plant.

HAZARDS AND OTHER CONDITIONS AFFECTING PLANT SAFETY

EAL #2

This EAL is based on a tornado striking (touching down) or high winds within the PROTECTED AREA.

[The high wind value should be based on site specific FSAR design basis as long as it is within the range of the instrumentation available for wind speed.]

Escalation of this emergency classification level, if appropriate, would be based on VISIBLE DAMAGE, or by other in plant conditions, via HA1.

EAL #3

This EAL addresses the effect of internal flooding caused by events such as component failures, equipment misalignment, or outage activity mishaps.

[The site specific areas include those areas that contain systems required for safe shutdown of the plant, which are not designed to be partially or fully submerged. The plant's IPEEE may provide insight into areas to be considered when developing this EAL.]

Escalation of this emergency classification level, if appropriate, would be based VISIBLE DAMAGE via HA1, or by other plant conditions.

EAL #4

This EAL addresses main turbine rotating component failures of sufficient magnitude to cause observable damage to the turbine casing or to the seals of the turbine generator. Generator seal damage observed after generator purge does not meet the intent of this EAL because it did not impact normal operation of the plant.

Of major concern is the potential for leakage of combustible fluids (lubricating oils) and gases (hydrogen cooling) to the plant environs. Actual FIRES and flammable gas build up are appropriately classified via HU2 and HU3.

This EAL is consistent with the definition of a NOUE while maintaining the anticipatory nature desired and recognizing the risk to non-safety related equipment.

Escalation of this emergency classification level, if appropriate, would be to HA1 based on damage done by PROJECTILES generated by the failure or by the radiological releases for a BWR, or in conjunction with a steam generator tube rupture, for a PWR. These latter events would be classified by the radiological ICs or Fission Product Barrier ICs.

EAL #5

This EAL addresses other site specific phenomena (such as hurricane, flood, or seiche) that can also be precursors of more serious events.

[Sites subject to severe weather as defined in the NUMARC station blackout initiatives should include an EAL based on activation of the severe weather mitigation procedures (e.g., precautionary shutdowns, diesel testing, staff call-outs, etc.).]

HAZARDS AND OTHER CONDITIONS AFFECTING PLANT SAFETY

HU2

Initiating Condition - NOTIFICATION OF UNUSUAL EVENT

FIRE within the PROTECTED AREA not extinguished within 15 minutes of detection or EXPLOSION within the PROTECTED AREA.

Operating Mode Applicability: All

Example Emergency Action Level: (1 or 2)

Note: The Emergency Director should not wait until the applicable time has elapsed, but should declare the event as soon as it is determined that the duration has exceeded, or will likely exceed, the applicable time.

1. FIRE not extinguished within 15 minutes of control room notification or verification of a control room FIRE alarm in **ANY** of the following areas:

(site specific area list)

2. EXPLOSION within the PROTECTED AREA.

Basis:

This EAL addresses the magnitude and extent of FIRES or EXPLOSIONS that may be potentially significant precursors of damage to safety systems. It addresses the FIRE / EXPLOSION, and not the degradation in performance of affected systems that may result.

As used here, detection is visual observation and report by plant personnel or sensor alarm indication.

EAL #1

The 15 minute time period begins with a credible notification that a FIRE is occurring, or indication of a fire detection system alarm/actuation. Verification of a fire detection system alarm/actuation includes actions that can be taken within the control room or other nearby site specific location to ensure that it is not spurious. An alarm is assumed to be an indication of a FIRE unless it is disproved within the 15 minute period by personnel dispatched to the scene. In other words, a personnel report from the scene may be used to disprove a sensor alarm if received within 15 minutes of the alarm, but shall not be required to verify the alarm.

The intent of this 15 minute duration is to size the FIRE and to discriminate against small FIRES that are readily extinguished (e.g., smoldering waste paper basket).

[The site specific list should be limited and applies to buildings and areas in actual contact with or immediately adjacent to VITAL AREAS or other significant buildings or areas. The intent of this IC is not to include buildings (i.e., warehouses) or areas that are not in actual contact with or immediately adjacent to VITAL AREAS. This excludes FIRES within administration buildings, waste-basket FIRES, and other small FIRES of no safety consequence. Immediately adjacent implies that the area immediately adjacent contains or may contain equipment or cabling that could impact equipment located in VITAL AREAS or the fire could damage equipment inside VITAL AREAS or that precludes access to VITAL AREAS.]

HAZARDS AND OTHER CONDITIONS AFFECTING PLANT SAFETY

EAL #2

This EAL addresses only those EXPLOSIONS of sufficient force to damage permanent structures or equipment within the PROTECTED AREA.

No attempt is made to assess the actual magnitude of the damage. The occurrence of the EXPLOSION is sufficient for declaration.

The Emergency director also needs to consider any security aspects of the EXPLOSION, if applicable.

Escalation of this emergency classification level, if appropriate, would be based on HA2.

HAZARDS AND OTHER CONDITIONS AFFECTING PLANT SAFETY

HU3

Initiating Condition - NOTIFICATION OF UNUSUAL EVENT

Release of toxic, corrosive, asphyxiant, or flammable gases deemed detrimental to NORMAL PLANT OPERATIONS.

Operating Mode Applicability: All

Example Emergency Action Levels: (1 or 2)

1. Toxic, corrosive, asphyxiant or flammable gases in amounts that have or could adversely affect NORMAL PLANT OPERATIONS.
2. Report by local, county or state officials for evacuation or sheltering of site personnel based on an off-site event.

Basis:

This EAL is based on the release of toxic, corrosive, asphyxiant or flammable gases of sufficient quantity to affect NORMAL PLANT OPERATIONS.

The fact that SCBA may be worn does not eliminate the need to declare the event.

This IC is not intended to require significant assessment or quantification. It assumes an uncontrolled process that has the potential to affect plant operations. This would preclude small or incidental releases, or releases that do not impact structures needed for plant operation.

An asphyxiant is a gas capable of reducing the level of oxygen in the body to dangerous levels. Most commonly, asphyxiants work by merely displacing air in an enclosed environment. This reduces the concentration of oxygen below the normal level of around 19%, which can lead to breathing difficulties, unconsciousness or even death.

Escalation of this emergency classification level, if appropriate, would be based on HA3.

HAZARDS AND OTHER CONDITIONS AFFECTING PLANT SAFETY

HU4

Initiating Condition - NOTIFICATION OF UNUSUAL EVENT

Confirmed SECURITY CONDITION or threat which indicates a potential degradation in the level of safety of the plant.

Operating Mode Applicability: All

Example Emergency Action Levels: (1 or 2 or 3)

1. A SECURITY CONDITION that does NOT involve a HOSTILE ACTION as reported by the (site specific security shift supervision).
2. A credible site specific security threat notification.
3. A validated notification from NRC providing information of an aircraft threat.

Basis:

Note: Timely and accurate communication between Security Shift Supervision and the Control Room is crucial for the implementation of effective Security EALs.

Security events which do not represent a potential degradation in the level of safety of the plant are reported under 10 CFR 73.71 or in some cases under 10 CFR 50.72. Security events assessed as HOSTILE ACTIONS are classifiable under HA4, HS4 and HG1.

A higher initial classification could be made based upon the nature and timing of the security threat and potential consequences. The licensee shall consider upgrading the emergency response status and emergency classification level in accordance with the site's Safeguards Contingency Plan and Emergency Plan.

EAL #1

Reference is made to site specific security shift supervision because these individuals are the designated personnel on-site qualified and trained to confirm that a security event is occurring or has occurred. Training on security event classification confirmation is closely controlled due to the strict secrecy controls placed on the plant Safeguards Contingency Plan.

This threshold is based on site specific security plans. Site specific Safeguards Contingency Plans are based on guidance provided by NEI 03-12.

EAL #2

This threshold is included to ensure that appropriate notifications for the security threat are made in a timely manner. This includes information of a credible threat. Only the plant to which the specific threat is made need declare the Notification of an Unusual Event.

The determination of "credible" is made through use of information found in the site specific Safeguards Contingency Plan.

HAZARDS AND OTHER CONDITIONS AFFECTING PLANT SAFETY

EAL #3

The intent of this EAL is to ensure that notifications for the aircraft threat are made in a timely manner and that OROs and plant personnel are at a state of heightened awareness regarding the credible threat. It is not the intent of this EAL to replace existing non-hostile related EALs involving aircraft.

This EAL is met when a plant receives information regarding an aircraft threat from NRC. Validation is performed by calling the NRC or by other approved methods of authentication. Only the plant to which the specific threat is made need declare the Unusual Event.

The NRC Headquarters Operations Officer (HOO) will communicate to the licensee if the threat involves an airliner (airliner is meant to be a large aircraft with the potential for causing significant damage to the plant). The status and size of the plane may be provided by NORAD through the NRC.

Escalation to Alert emergency classification level would be via HA4 would be appropriate if the threat involves an airliner within 30 minutes of the plant.

HAZARDS AND OTHER CONDITIONS AFFECTING PLANT SAFETY

HU5

Initiating Condition - NOTIFICATION OF UNUSUAL EVENT

Other conditions exist which in the judgment of the Emergency Director warrant declaration of a NOUE.

Operating Mode Applicability: All

Example Emergency Action Level:

1. Other conditions exist which in the judgment of the Emergency Director indicate that events are in progress or have occurred which indicate a potential degradation of the level of safety of the plant or indicate a security threat to facility protection has been initiated. No releases of radioactive material requiring off-site response or monitoring are expected unless further degradation of safety systems occurs.

Basis:

This EAL addresses unanticipated conditions not addressed explicitly elsewhere but that warrant declaration of an emergency because conditions exist which are believed by the Emergency Director to fall under the NOUE emergency classification level.

HAZARDS AND OTHER CONDITIONS AFFECTING PLANT SAFETY

HA1

Initiating Condition - ALERT

Natural or destructive phenomena affecting VITAL AREAS.

Operating Mode Applicability: All

Example Emergency Action Levels: (1 or 2 or 3 or 4 or 5 or 6)

1. a. Seismic event greater than Operating Basis Earthquake (OBE) as indicated by (site specific seismic instrumentation) reading (site specific OBE limit).

AND
- b. Earthquake confirmed by **ANY** of the following:
 - Earthquake felt in plant
 - National Earthquake Center
 - Control Room indication of degraded performance of systems required for the safe shutdown of the plant.
2. Tornado striking or high winds greater than (site specific mph) resulting in **VISIBLE DAMAGE** to **ANY** of the following structures containing safety systems or components **OR** control room indication of degraded performance of those safety systems:

(site specific structure list)
3. Internal flooding in **ANY** of the following areas resulting in an electrical shock hazard that precludes access to operate or monitor safety equipment **OR** control room indication of degraded performance of those safety systems:

(site specific area list)
4. Turbine failure-generated **PROJECTILES** resulting in **VISIBLE DAMAGE** to or penetration of **ANY** of the following structures containing safety systems or components **OR** control room indication of degraded performance of those safety systems:

(site specific structure list)
5. Vehicle crash resulting in **VISIBLE DAMAGE** to **ANY** of the following structures containing safety systems or components **OR** control room indication of degraded performance of those safety systems:

(site specific structure list)
6. (Site specific occurrences) resulting in **VISIBLE DAMAGE** to **ANY** of the following structures containing safety systems or components **OR** control room indication of degraded performance of those safety systems:

HAZARDS AND OTHER CONDITIONS AFFECTING PLANT SAFETY

(site specific structure list)

Basis:

These EALs escalate from HU1 in that the occurrence of the event has resulted in VISIBLE DAMAGE to plant structures or areas containing equipment necessary for a safe shutdown, or has caused damage to the safety systems in those structures evidenced by control room indications of degraded system response or performance. The occurrence of VISIBLE DAMAGE and/or degraded system response is intended to discriminate against lesser events. The initial report should not be interpreted as mandating a lengthy damage assessment prior to classification. No attempt is made in this EAL to assess the actual magnitude of the damage. The significance here is not that a particular system or structure was damaged, but rather, that the event was of sufficient magnitude to cause this degradation.

Escalation of this emergency classification level, if appropriate, would be based on System Malfunction ICs.

EALs #2 - #5

[These EALs should specify site specific structures or areas that contain safety system, or component and functions required for safe shutdown of the plant. Site specific Safe Shutdown Analysis should be consulted for equipment and plant areas required to establish or maintain safe shutdown.]

EAL #1

Seismic events of this magnitude can result in a VITAL AREA being subjected to forces beyond design limits, and thus damage may be assumed to have occurred to plant safety systems.

[This threshold should be based on site specific FSAR design basis. See EPRI-sponsored "Guidelines for Nuclear Plant Response to an Earthquake", dated October 1989, for information on seismic event categories.]

The National Earthquake Center can confirm if an earthquake has occurred in the area of the plant.

EAL #2

This EAL is based on a tornado striking (touching down) or high winds that have caused VISIBLE DAMAGE to structures containing functions or systems required for safe shutdown of the plant.

[The high wind value should be based on site specific FSAR design basis as long as it is within the range of the instrumentation available for wind speed.]

EAL #3

This EAL addresses the effect of internal flooding caused by events such as component failures, equipment misalignment, or outage activity mishaps. It is based on the degraded performance of systems, or has created industrial safety hazards (e.g., electrical shock) that preclude necessary access to operate or monitor safety equipment. The inability to access, operate or monitor safety equipment represents an actual or substantial potential degradation of the level of safety of the plant.

HAZARDS AND OTHER CONDITIONS AFFECTING PLANT SAFETY

Flooding as used in this EAL describes a condition where water is entering the room faster than installed equipment is capable of removal, resulting in a rise of water level within the room. Classification of this EAL should not be delayed while corrective actions are being taken to isolate the water source.

[The site specific areas include those areas that contain systems required for safe shutdown of the plant, which are not designed to be partially or fully submerged. The plant's IPEEE may provide insight into areas to be considered when developing this EAL.]

EAL #4

This EAL addresses the threat to safety related equipment imposed by PROJECTILES generated by main turbine rotating component failures. Therefore, this EAL is consistent with the definition of an ALERT in that the potential exists for actual or substantial potential degradation of the level of safety of the plant.

[The site specific list of areas should include all areas containing safety structure, system, or component, their controls, and their power supplies.]

EAL #5

This EAL addresses vehicle crashes within the PROTECTED AREA that results in VISIBLE DAMAGE to VITAL AREAS or indication of damage to safety structures, systems, or components containing functions and systems required for safe shutdown of the plant.

EAL #6

This EAL addresses other site specific phenomena that result in VISIBLE DAMAGE to VITAL AREAS or results in indication of damage to safety structures, systems, or components containing functions and systems required for safe shutdown of the plant (such as hurricane, flood, or seiche) that can also be precursors of more serious events.

[Sites subject to severe weather as defined in the NUMARC station blackout initiatives should include an EAL based on activation of the severe weather mitigation procedures (e.g., precautionary shutdowns, diesel testing, staff call-outs, etc.).]

HAZARDS AND OTHER CONDITIONS AFFECTING PLANT SAFETY

HA2

Initiating Condition - ALERT

FIRE or EXPLOSION affecting the operability of plant safety systems required to establish or maintain safe shutdown.

Operating Mode Applicability: All

Example Emergency Action Level:

1. FIRE or EXPLOSION resulting in VISIBLE DAMAGE to **ANY** of the following structures containing safety systems or components **OR** control room indication of degraded performance of those safety systems:

(site specific structure list)

Basis:

VISIBLE DAMAGE is used to identify the magnitude of the FIRE or EXPLOSION and to discriminate against minor FIRES and EXPLOSIONS.

The reference to structures containing safety systems or components is included to discriminate against FIRES or EXPLOSIONS in areas having a low probability of affecting safe operation. The significance here is not that a safety system was degraded but the fact that the FIRE or EXPLOSION was large enough to cause damage to these systems.

The use of VISIBLE DAMAGE should not be interpreted as mandating a lengthy damage assessment prior to classification. The declaration of an Alert and the activation of the Technical Support Center will provide the Emergency Director with the resources needed to perform detailed damage assessments.

The Emergency Director also needs to consider any security aspects of the EXPLOSION.

[This EAL should specify site specific structures or areas that contain safety system, or component and functions required for safe shutdown of the plant. Site specific Safe Shutdown Analysis should be consulted for equipment and plant areas required to establish or maintain safe shutdown.]

Escalation of this emergency classification level, if appropriate, will be based on System Malfunctions, Fission Product Barrier Degradation or Abnormal Rad Levels / Radiological Effluent ICs.

HAZARDS AND OTHER CONDITIONS AFFECTING PLANT SAFETY

HA3

Initiating Condition - ALERT

Access to a VITAL AREA is prohibited due to toxic, corrosive, asphyxiant or flammable gases which jeopardize operation of operable equipment required to maintain safe operations or safely shutdown the reactor.

Operating Mode Applicability: All

Example Emergency Action Levels:

Note: If the equipment in the stated area was already inoperable, or out of service, before the event occurred, then this EAL should not be declared as it will have no adverse impact on the ability of the plant to safely operate or safely shutdown beyond that already allowed by Technical Specifications at the time of the event.

1. Access to a VITAL AREA is prohibited due to toxic, corrosive, asphyxiant or flammable gases which jeopardize operation of systems required to maintain safe operations or safely shutdown the reactor.

Basis:

Gases in a VITAL AREA can affect the ability to safely operate or safely shutdown the reactor.

The fact that SCBA may be worn does not eliminate the need to declare the event.

Declaration should not be delayed for confirmation from atmospheric testing if the atmosphere poses an immediate threat to life and health or an immediate threat of severe exposure to gases. This could be based upon documented analysis, indication of personal ill effects from exposure, or operating experience with the hazards.

If the equipment in the stated area was already inoperable, or out of service, before the event occurred, then this EAL should not be declared as it will have no adverse impact on the ability of the plant to safely operate or safely shutdown beyond that already allowed by Technical Specifications at the time of the event.

An asphyxiant is a gas capable of reducing the level of oxygen in the body to dangerous levels. Most commonly, asphyxiants work by merely displacing air in an enclosed environment. This reduces the concentration of oxygen below the normal level of around 19%, which can lead to breathing difficulties, unconsciousness or even death.

An uncontrolled release of flammable gasses within a facility structure has the potential to affect safe operation of the plant by limiting either operator or equipment operations due to the potential for ignition and resulting equipment damage/personnel injury. Flammable gasses, such as hydrogen and acetylene, are routinely used to maintain plant systems (hydrogen) or to repair equipment/components (acetylene - used in welding). This EAL assumes concentrations of flammable gasses which can ignite/support combustion.

Escalation of this emergency classification level, if appropriate, will be based on System Malfunctions, Fission Product Barrier Degradation or Abnormal Rad Levels / Radioactive Effluent ICs.

HAZARDS AND OTHER CONDITIONS AFFECTING PLANT SAFETY

HA4

Initiating Condition - ALERT

HOSTILE ACTION within the OWNER CONTROLLED AREA or airborne attack threat.

Operating Mode Applicability: All

Example Emergency Action Level: (1 or 2)

1. A HOSTILE ACTION is occurring or has occurred within the OWNER CONTROLLED AREA as reported by the (site specific security shift supervision).
2. A validated notification from NRC of an airliner attack threat within 30 minutes of the site.

Basis:

Note: Timely and accurate communication between Security Shift Supervision and the Control Room is crucial for the implementation of effective Security EALs.

These EALs address the contingency for a very rapid progression of events, such as that experienced on September 11, 2001. They are not premised solely on the potential for a radiological release. Rather the issue includes the need for rapid assistance due to the possibility for significant and indeterminate damage from additional air, land or water attack elements.

The fact that the site is under serious attack or is an identified attack target with minimal time available for further preparation or additional assistance to arrive requires a heightened state of readiness and implementation of protective measures that can be effective (such as on-site evacuation, dispersal or sheltering).

EAL #1

This EAL addresses the potential for a very rapid progression of events due to a HOSTILE ACTION. It is not intended to address incidents that are accidental events or acts of civil disobedience, such as small aircraft impact, hunters, or physical disputes between employees within the OCA. Those events are adequately addressed by other EALs.

Note that this EAL is applicable for any HOSTILE ACTION occurring, or that has occurred, in the OWNER CONTROLLED AREA. This includes ISFSI's that may be outside the PROTECTED AREA but still within the OWNER CONTROLLED AREA.

[Although nuclear plant security officers are well trained and prepared to protect against HOSTILE ACTION, it is appropriate for OROs to be notified and encouraged to begin activation (if they do not normally) to be better prepared should it be necessary to consider further actions.]

[If not previously notified by the NRC that the airborne HOSTILE ACTION was intentional, then it would be expected, although not certain, that notification by an appropriate Federal agency would follow. In this case, appropriate federal agency is intended to be NORAD, FBI, FAA or NRC. However, the declaration should not be unduly delayed awaiting Federal notification.]

HAZARDS AND OTHER CONDITIONS AFFECTING PLANT SAFETY

EAL #2

This EAL addresses the immediacy of an expected threat arrival or impact on the site within a relatively short time.

The intent of this EAL is to ensure that notifications for the airliner attack threat are made in a timely manner and that OROs and plant personnel are at a state of heightened awareness regarding the credible threat. Airliner is meant to be a large aircraft with the potential for causing significant damage to the plant.

This EAL is met when a plant receives information regarding an airliner attack threat from NRC and the airliner is within 30 minutes of the plant. Only the plant to which the specific threat is made need declare the Alert.

The NRC Headquarters Operations Officer (HOO) will communicate to the licensee if the threat involves an airliner (airliner is meant to be a large aircraft with the potential for causing significant damage to the plant). The status and size of the plane may be provided by NORAD through the NRC.

HAZARDS AND OTHER CONDITIONS AFFECTING PLANT SAFETY

HA5

Initiating Condition - ALERT

Control room evacuation has been initiated.

Operating Mode Applicability: All

Example Emergency Action Level:

1. (Site-specific procedure) requires control room evacuation.

Basis:

With the control room evacuated, additional support, monitoring and direction through the Technical Support Center and/or other emergency response facilities may be necessary.

Inability to establish plant control from outside the control room will escalate this event to a Site Area Emergency.

HAZARDS AND OTHER CONDITIONS AFFECTING PLANT SAFETY

HA6

Initiating Condition - ALERT

Other conditions exist which in the judgment of the Emergency Director warrant declaration of an Alert.

Operating Mode Applicability: All

Example Emergency Action Level:

1. Other conditions exist which in the judgment of the Emergency Director indicate that events are in progress or have occurred which involve an actual or potential substantial degradation of the level of safety of the plant or a security event that involves probable life threatening risk to site personnel or damage to site equipment because of HOSTILE ACTION. Any releases are expected to be limited to small fractions of the EPA Protective Action Guideline exposure levels.

Basis:

This EAL addresses unanticipated conditions not addressed explicitly elsewhere but that warrant declaration of an emergency because conditions exist which are believed by the Emergency Director to fall under the Alert emergency classification level.

Initiating Condition - SITE AREA EMERGENCY

Control room evacuation has been initiated and plant control cannot be established.

Operating Mode Applicability: All

Example Emergency Action Level:

1. a. Control room evacuation has been initiated.
AND
- b. Control of the plant cannot be established within (site specific minutes).

Basis:

The intent of this IC is to capture those events where control of the plant cannot be reestablished in a timely manner. In this case, expeditious transfer of control of safety systems has not occurred (although fission product barrier damage may not yet be indicated).

The intent of the EAL is to establish control of important plant equipment and knowledge of important plant parameters in a timely manner. Primary emphasis should be placed on those components and instruments that supply protection for and information about safety functions. Typically, these safety functions are reactivity control (ability to shutdown the reactor and maintain it shutdown), reactor water level (ability to cool the core), and decay heat removal (ability to maintain a heat sink) for a BWR. The equivalent functions for a PWR are reactivity control, RCS inventory, and secondary heat removal.

The determination of whether or not control is established at the remote shutdown panel is based on Emergency Director (ED) judgment. The Emergency Director is expected to make a reasonable, informed judgment within the site specific time for transfer that the licensee has control of the plant from the remote shutdown panel.

[The site specific time for transfer is based on analysis or assessments as to how quickly control must be reestablished without core uncovering and/or core damage. This time should not exceed 15 minutes without additional justification.]

Escalation of this emergency classification level, if appropriate, would be by Fission Product Barrier Degradation or Abnormal Rad Levels/Radiological Effluent EALs.

HAZARDS AND OTHER CONDITIONS AFFECTING PLANT SAFETY

HS3

Initiating Condition - SITE AREA EMERGENCY

Other conditions exist which in the judgment of the Emergency Director warrant declaration of a Site Area Emergency.

Operating Mode Applicability: All

Example Emergency Action Level:

1. Other conditions exist which in the judgment of the Emergency Director indicate that events are in progress or have occurred which involve actual or likely major failures of plant functions needed for protection of the public or HOSTILE ACTION that results in intentional damage or malicious acts; (1) toward site personnel or equipment that could lead to the likely failure of or; (2) that prevent effective access to equipment needed for the protection of the public. Any releases are not expected to result in exposure levels which exceed EPA Protective Action Guideline exposure levels beyond the site boundary.

Basis:

This EAL addresses unanticipated conditions not addressed explicitly elsewhere but that warrant declaration of an emergency because conditions exist which are believed by the Emergency Director to fall under the emergency classification level description for Site Area Emergency.

HAZARDS AND OTHER CONDITIONS AFFECTING PLANT SAFETY

HS4

Initiating Condition - SITE AREA EMERGENCY

HOSTILE ACTION within the PROTECTED AREA.

Operating Mode Applicability: All

Example Emergency Action Level:

1. A HOSTILE ACTION is occurring or has occurred within the PROTECTED AREA as reported by the (site security shift supervision).

Basis:

This condition represents an escalated threat to plant safety above that contained in the Alert in that a HOSTILE FORCE has progressed from the OWNER CONTROLLED AREA to the PROTECTED AREA.

This EAL addresses the contingency for a very rapid progression of events, such as that experienced on September 11, 2001. It is not premised solely on the potential for a radiological release. Rather the issue includes the need for rapid assistance due to the possibility for significant and indeterminate damage from additional air, land or water attack elements.

The fact that the site is under serious attack with minimal time available for further preparation or additional assistance to arrive requires ORO readiness and preparation for the implementation of protective measures.

This EAL addresses the potential for a very rapid progression of events due to a HOSTILE ACTION. It is not intended to address incidents that are accidental events or acts of civil disobedience, such as small aircraft impact, hunters, or physical disputes between employees within the PROTECTED AREA. Those events are adequately addressed by other EALs.

[Although nuclear plant security officers are well trained and prepared to protect against HOSTILE ACTION, it is appropriate for OROs to be notified and encouraged to begin preparations for public protective actions (if they do not normally) to be better prepared should it be necessary to consider further actions.]

[If not previously notified by NRC that the airborne HOSTILE ACTION was intentional, then it would be expected, although not certain, that notification by an appropriate Federal agency would follow. In this case, appropriate federal agency is intended to be NORAD, FBI, FAA or NRC. However, the declaration should not be unduly delayed awaiting Federal notification.]

Escalation of this emergency classification level, if appropriate, would be based on actual plant status after impact or progression of attack.

HAZARDS AND OTHER CONDITIONS AFFECTING PLANT SAFETY

HG1

Initiating Condition - GENERAL EMERGENCY

HOSTILE ACTION resulting in loss of physical control of the facility.

Operating Mode Applicability: All

Example Emergency Action Level: (1 or 2)

1. A HOSTILE ACTION has occurred such that plant personnel are unable to operate equipment required to maintain safety functions.
2. A HOSTILE ACTION has caused failure of Spent Fuel Cooling Systems and IMMEDIATE fuel damage is likely for a freshly off-loaded reactor core in pool.

Basis:

EAL #1

This EAL encompasses conditions under which a HOSTILE ACTION has resulted in a loss of physical control of VITAL AREAS (containing vital equipment or controls of vital equipment) required to maintain safety functions and control of that equipment cannot be transferred to and operated from another location.

[Typically, these safety functions are reactivity control (ability to shut down the reactor and keep it shutdown) reactor water level (ability to cool the core), and decay heat removal (ability to maintain a heat sink) for a BWR. The equivalent functions for a PWR are reactivity control, RCS inventory, and secondary heat removal.]

[Loss of physical control of the control room or remote shutdown capability alone may not prevent the ability to maintain safety functions per se. Design of the remote shutdown capability and the location of the transfer switches should be taken into account. Primary emphasis should be placed on those components and instruments that supply protection for and information about safety functions.]

If control of the plant equipment necessary to maintain safety functions can be transferred to another location, then the threshold is not met.

EAL #2

This EAL addresses failure of spent fuel cooling systems as a result of HOSTILE ACTION if IMMEDIATE fuel damage is likely, such as when a freshly off-loaded reactor core is in the spent fuel pool.

[A freshly off-loaded reactor core is defined by site specific criteria.]

Initiating Condition - GENERAL EMERGENCY

Other conditions exist which in the judgment of the Emergency Director warrant declaration of a General Emergency.

Operating Mode Applicability: All

Example Emergency Action Level:

1. Other conditions exist which in the judgment of the Emergency Director indicate that events are in progress or have occurred which involve actual or IMMEDIATE substantial core degradation or melting with potential for loss of containment integrity or HOSTILE ACTION that results in an actual loss of physical control of the facility. Releases can be reasonably expected to exceed EPA Protective Action Guideline exposure levels off-site for more than the immediate site area.

Basis:

This EAL addresses unanticipated conditions not addressed explicitly elsewhere but that warrant declaration of an emergency because conditions exist which are believed by the Emergency Director to fall under the emergency classification level description for General Emergency.

5.11 SYSTEM MALFUNCTION EALS

Table 5-S-1: Recognition Category “S” Initiating Condition Matrix

GENERAL EMERGENCY	SITE AREA EMERGENCY	ALERT	UNUSUAL EVENT
<p>SG1 Prolonged loss of all Off-site and all On-site AC power to emergency busses.</p> <p><i>Op. Modes: Power Operation, Startup, Hot Standby, Hot Shutdown</i></p>	<p>SS1 Loss of all Off-site and all On-site AC power to emergency busses for 15 minutes or longer.</p> <p><i>Op. Modes: Power Operation, Startup, Hot Standby, Hot Shutdown</i></p>	<p>SA5 AC power capability to emergency busses reduced to a single power source for 15 Minutes or longer such that any additional single failure would result in station blackout.</p> <p><i>Op. Modes: Power Operation, Startup, Hot Standby, Hot Shutdown</i></p>	<p>SU1 Loss of all Off-site AC power to emergency busses for 15 minutes or longer.</p> <p><i>Op. Modes: Power Operation, Startup, Hot Standby, Hot Shutdown</i></p>
<p>SG2 Automatic Scram (Trip) and all manual actions fail to shutdown the reactor and indication of an extreme challenge to the ability to cool the core exists.</p> <p><i>Op. Modes: Power Operation, Startup</i></p>	<p>SS3 Loss of all vital DC power for 15 minutes or longer.</p> <p><i>Op. Modes: Power Operation, Startup, Hot Standby, Hot Shutdown</i></p>	<p>SA2 Automatic Scram (Trip) fails to shutdown the reactor and the manual actions taken from the reactor control console are successful in shutting down the reactor.</p> <p><i>Op. Modes: Power Operation, Startup</i></p>	<p>SU8 Inadvertent criticality.</p> <p><i>Op. Modes: Hot Standby, Hot Shutdown</i></p>
<p>SG2 Automatic Scram (Trip) and all manual actions fail to shutdown the reactor and indication of an extreme challenge to the ability to cool the core exists.</p> <p><i>Op. Modes: Power Operation, Startup</i></p>	<p>SS2 Automatic Scram (Trip) fails to shutdown the reactor and manual actions taken from the reactor control console are not successful in shutting down the reactor.</p> <p><i>Op. Modes: Power Operation, Startup</i></p>	<p>SA4 UNPLANNED loss of safety system annunciation or indication in control room with EITHER (1) a SIGNIFICANT TRANSIENT in progress, or (2) compensatory indicators are unavailable.</p> <p><i>Op. Modes: Power Operation, Startup, Hot Standby, Hot Shutdown</i></p>	<p>SU3 UNPLANNED loss of safety system annunciation or indication in the control room for 15 minutes or longer.</p> <p><i>Op. Modes: Power Operation, Startup, Hot Standby, Hot Shutdown</i></p>
<p>SG2 Automatic Scram (Trip) and all manual actions fail to shutdown the reactor and indication of an extreme challenge to the ability to cool the core exists.</p> <p><i>Op. Modes: Power Operation, Startup</i></p>	<p>SS6 Inability to monitor a SIGNIFICANT TRANSIENT in progress.</p> <p><i>Op. Modes: Power Operation, Startup, Hot Standby, Hot Shutdown</i></p>	<p>SA4 UNPLANNED loss of safety system annunciation or indication in control room with EITHER (1) a SIGNIFICANT TRANSIENT in progress, or (2) compensatory indicators are unavailable.</p> <p><i>Op. Modes: Power Operation, Startup, Hot Standby, Hot Shutdown</i></p>	<p>SU3 UNPLANNED loss of safety system annunciation or indication in the control room for 15 minutes or longer.</p> <p><i>Op. Modes: Power Operation, Startup, Hot Standby, Hot Shutdown</i></p>

Table 5-S-1: Recognition Category “S” Initiating Condition Matrix

GENERAL EMERGENCY

SITE AREA EMERGENCY

ALERT

UNUSUAL EVENT

- SU2** Inability to reach required shutdown within Technical Specification limits.
Op. Modes: Power Operation, Startup, Hot Standby, Hot Shutdown
- SU4** Fuel Clad degradation.
Op. Modes: Power Operation, Startup, Hot Standby, Hot Shutdown
- SU5** RCS leakage.
Op. Modes: Power Operation, Startup, Hot Standby, Hot Shutdown
- SU6** Loss of all On-site or Off-site communications capabilities.
Op. Modes: Power Operation, Startup, Hot Standby, Hot Shutdown

SYSTEM MALFUNCTIONS

SU1

Initiating Condition - NOTIFICATION OF UNUSUAL EVENT

Loss of all Off-site AC power to emergency busses for 15 minutes or longer.

Operating Mode Applicability: Power Operation, Startup, Hot Standby, Hot Shutdown

Example Emergency Action Level:

Note: The Emergency Director should not wait until the applicable time has elapsed, but should declare the event as soon as it is determined that the condition has exceeded, or will likely exceed, the applicable time.

1. Loss of all off-site AC power to (site specific emergency busses) for 15 minutes or longer.

Basis:

Prolonged loss of off-site AC power reduces required redundancy and potentially degrades the level of safety of the plant by rendering the plant more vulnerable to a complete loss of AC power to emergency busses.

Fifteen minutes was selected as a threshold to exclude transient or momentary losses of off-site power.

[At multi-unit stations, the EALs should allow credit for operation of installed design features, such as cross-ties or swing diesels, provided that abnormal or emergency operating procedures address their use. However, these stations must also consider the impact of this condition on other shared safety functions in developing the site specific EAL.]

[Plants that have a proceduralized capability to cross-tie AC power from an off-site power supply of a companion unit may take credit for the redundant power source in the associated EAL for this IC.]

SYSTEM MALFUNCTIONS

SU2

Initiating Condition - NOTIFICATION OF UNUSUAL EVENT

Inability to reach required shutdown within Technical Specification limits.

Operating Mode Applicability: Power Operation, Startup, Hot Standby, Hot Shutdown

Example Emergency Action Level:

1. Plant is not brought to required operating mode within Technical Specifications LCO Action Statement Time.

Basis:

Limiting Conditions of Operation (LCOs) require the plant to be brought to a required operating mode when the Technical Specification required configuration cannot be restored. Depending on the circumstances, this may or may not be an emergency or precursor to a more severe condition. In any case, the initiation of plant shutdown required by the site Technical Specifications requires a four hour report under 10 CFR 50.72 (b) Non-emergency events. The plant is within its safety envelope when being shut down within the allowable action statement time in the Technical Specifications. An immediate NOUE is required when the plant is not brought to the required operating mode within the allowable action statement time in the Technical Specifications. Declaration of a NOUE is based on the time at which the LCO-specified action statement time period elapses under the site Technical Specifications and is not related to how long a condition may have existed.

[Other required Technical Specification shutdowns that involve precursors to more serious events are addressed by other System Malfunction, Hazards, or Fission Product Barrier Degradation ICs.]

SYSTEM MALFUNCTIONS

SU3

Initiating Condition - NOTIFICATION OF UNUSUAL EVENT

UNPLANNED loss of safety system annunciation or indication in the control room for 15 minutes or longer.

Operating Mode Applicability: Power Operation, Startup, Hot Standby, Hot Shutdown

Example Emergency Action Level:

Note: The Emergency Director should not wait until the applicable time has elapsed, but should declare the event as soon as it is determined that the condition has exceeded, or will likely exceed, the applicable time.

1. UNPLANNED Loss of greater than approximately 75% of the following for 15 minutes or longer:
 - a. (Site specific control room safety system annunciation)

OR

 - b. (Site specific control room safety system indication)

Basis:

This IC and its associated EAL are intended to recognize the difficulty associated with monitoring changing plant conditions without the use of a major portion of the annunciation or indication equipment.

Recognition of the availability of computer based indication equipment is considered [e.g., *SPDS, plant computer, etc.*].

"Planned" loss of annunciators or indicators includes scheduled maintenance and testing activities.

Quantification is arbitrary, however, it is estimated that if approximately 75% of the safety system annunciators or indicators are lost, there is an increased risk that a degraded plant condition could go undetected. It is not intended that plant personnel perform a detailed count of the instrumentation lost but use the value as a judgment threshold for determining the severity of the plant conditions.

It is further recognized that most plant designs provide redundant safety system indication powered from separate uninterruptible power supplies. While failure of a large portion of annunciators is more likely than a failure of a large portion of indications, the concern is included in this EAL due to difficulty associated with assessment of plant conditions. The loss of specific, or several, safety system indicators should remain a function of that specific system or component operability status. This will be addressed by the specific Technical Specification. The initiation of a Technical Specification imposed plant shutdown related to the instrument loss will be reported via 10 CFR 50.72. If the shutdown is not in compliance with the Technical

SYSTEM MALFUNCTIONS

Specification action, the NOUE is based on SU2 "Inability to Reach Required Shutdown Within Technical Specification Limits."

[Site specific annunciators or indicators for this EAL must include those identified in the Abnormal Operating Procedures, in the Emergency Operating Procedures, and in other EALs (e.g., area, process, and/or effluent rad monitors, etc.).]

Fifteen minutes was selected as a threshold to exclude transient or momentary power losses.

[Due to the limited number of safety systems in operation during cold shutdown, refueling, and defueled modes, no IC is indicated during these modes of operation.]

This NOUE will be escalated to an Alert based on a concurrent loss of compensatory indications or if a SIGNIFICANT TRANSIENT is in progress during the loss of annunciation or indication.

SYSTEM MALFUNCTIONS

SU4

Initiating Condition - NOTIFICATION OF UNUSUAL EVENT

Fuel Clad degradation.

Operating Mode Applicability: Power Operation, Startup, Hot Standby, Hot Shutdown

Example Emergency Action Levels: (1 or 2)

1. (Site specific radiation monitor readings indicating fuel clad degradation greater than Technical Specification allowable limits.)
2. (Site specific coolant sample activity value indicating fuel clad degradation greater than Technical Specification allowable limits.)

Basis:

This EAL is included because it is a precursor of more serious conditions and, as result, is considered to be a potential degradation of the level of safety of the plant.

Escalation of this EAL to the Alert level is via the Fission Product Barriers.

EAL #1

This threshold addresses site-specific radiation monitor readings that provide indication of a degradation of fuel clad integrity.

[Such as BWR air ejector monitors, PWR failed fuel monitors, etc.]

EAL #2

This threshold addresses coolant samples exceeding coolant technical specifications for transient iodine spiking limits.

SYSTEM MALFUNCTIONS

SU5

Initiating Condition - NOTIFICATION OF UNUSUAL EVENT

RCS leakage.

Operating Mode Applicability: Power Operation, Startup, Hot Standby, Hot Shutdown

Example Emergency Action Levels: (1 or 2)

1. Unidentified or pressure boundary leakage greater than 10 gpm.
2. Identified leakage greater than 25 gpm.

Basis:

This IC is included as a NOUE because it may be a precursor of more serious conditions and, as result, is considered to be a potential degradation of the level of safety of the plant. The 10 gpm value for the unidentified or pressure boundary leakage was selected as it is observable with normal control room indications. Lesser values must generally be determined through time-consuming surveillance tests (e.g., mass balances).

Relief valve normal operation should be excluded from this IC. However, a relief valve that operates and fails to close per design should be considered applicable to this IC if the relief valve cannot be isolated.

The EAL for identified leakage is set at a higher value due to the lesser significance of identified leakage in comparison to unidentified or pressure boundary leakage. In either case, escalation of this IC to the Alert level is via Fission Product Barrier Degradation ICs.

SYSTEM MALFUNCTIONS

SU6

Initiating Condition - NOTIFICATION OF UNUSUAL EVENT

Loss of all On-site or Off-site communications capabilities.

Operating Mode Applicability: Power Operation, Startup, Hot Standby, Hot Shutdown

Example Emergency Action Levels: (1 or 2)

1. Loss of all of the following on-site communication methods affecting the ability to perform routine operations.

(site specific list of communications methods)
2. Loss of all of the following off-site communication methods affecting the ability to perform offsite notifications.

(site specific list of communications methods)

Basis:

The purpose of this IC and its associated EALs is to recognize a loss of communications capability that either defeats the plant operations staff ability to perform routine tasks necessary for plant operations or the ability to communicate issues with off-site authorities.

[The loss of off-site communications ability is expected to be significantly more comprehensive than the condition addressed by 10 CFR 50.72.]

The availability of one method of ordinary off-site communications is sufficient to inform federal, state, and local authorities of plant problems. This EAL is intended to be used only when extraordinary means (e.g., relaying of information from non-routine radio transmissions, individuals being sent to off-site locations, etc.) are being used to make communications possible.

[Site specific list for on-site communications loss must encompass the loss of all means of communications (e.g., commercial telephones, sound powered phone systems, page party system (Gaitronics) and radios / walkie talkies) routinely used for operations.]

[Site specific list for off-site communications loss must encompass the loss of all means of communications with off-site authorities. This should include the ENS, commercial telephone lines, telecopy transmissions, and dedicated phone systems that are routinely used for offsite emergency notifications.]

SYSTEM MALFUNCTIONS

SU8

Initiating Condition - NOTIFICATION OF UNUSUAL EVENT

Inadvertent criticality.

Operating Mode Applicability: Hot Standby, Hot Shutdown

Example Emergency Action Level:

1. UNPLANNED sustained positive period observed on nuclear instrumentation. [BWR]
1. UNPLANNED sustained positive startup rate observed on nuclear instrumentation. [PWR]

Basis:

This IC addresses inadvertent criticality events. This IC indicates a potential degradation of the level of safety of the plant, warranting a NOUE classification. This IC excludes inadvertent criticalities that occur during planned reactivity changes associated with reactor startups (e.g., criticality earlier than estimated).

[This condition can be identified using period monitors/startup rate monitor. The term "sustained" is used in order to allow exclusion of expected short term positive periods/startup rates from planned control rod movements for PWRs and BWRs (such as shutdown bank withdrawal for PWRs). These short term positive periods/startup rates are the result of the increase in neutron population due to subcritical multiplication.]

Escalation would be by the Fission Product Barrier Table, as appropriate to the operating mode at the time of the event.

SYSTEM MALFUNCTIONS

SA2

Initiating Condition - ALERT

Automatic Scram (Trip) fails to shutdown the reactor and the manual actions taken from the reactor control console are successful in shutting down the reactor.

Operating Mode Applicability: Power Operation, Startup

Example Emergency Action Level:

1. a. An automatic scram (trip) failed to shutdown the reactor.

AND

-
- b. Manual actions taken at the reactor control console successfully shutdown the reactor as indicated by (site specific indications of plant shutdown).

Basis:

[The reactor should be considered shutdown when it producing less heat than the maximum decay heat load for which the safety systems are designed (typically 3 to 5% power). For plants using CSFSTs, this EAL equates to the criteria used to determine a valid Subcriticality Red Path. For BWRs this EAL should be the APRM downscale trip setpoint.]

Manual scram (trip) actions taken at the reactor control console are any set of actions by the reactor operator(s) which causes or should cause control rods to be rapidly inserted into the core and shuts down the reactor.

[If the manual scram (trip) switches/pushbuttons on the control room console panels are considered an automatic input into the Reactor Protection System, a failure to scram (trip) without any other automatic input would make this threshold applicable.]

This condition indicates failure of the automatic protection system to scram (trip) the reactor. This condition is more than a potential degradation of a safety system in that a front line automatic protection system did not function in response to a plant transient. Thus the plant safety has been compromised because design limits of the fuel may have been exceeded. An Alert is indicated because conditions may exist that lead to potential loss of fuel clad or RCS and because of the failure of the Reactor Protection System to automatically shutdown the plant.

If manual actions taken at the reactor control console fail to shutdown the reactor, the event would escalate to a Site Area Emergency.

SYSTEM MALFUNCTIONS

SA4

Initiating Condition - ALERT

UNPLANNED Loss of safety system annunciation or indication in the control room with EITHER (1) a SIGNIFICANT TRANSIENT in progress, or (2) compensatory indicators unavailable.

Operating Mode Applicability: Power Operation, Startup, Hot Standby, Hot Shutdown

Example Emergency Action Level:

Note: The Emergency Director should not wait until the applicable time has elapsed, but should declare the event as soon as it is determined that the condition has exceeded, or will likely exceed, the applicable time.

1. a. UNPLANNED loss of greater than approximately 75% of the following for 15 minutes or longer:
 - (Site specific control room safety system annunciation)

OR

 - (Site specific control room safety system indication)
- b. **EITHER** of the following:
 - A SIGNIFICANT TRANSIENT is in progress.
 - Compensatory indications are unavailable.

Basis:

This IC is intended to recognize the difficulty associated with monitoring changing plant conditions without the use of a major portion of the annunciation or indication equipment during a SIGNIFICANT TRANSIENT.

[Recognition of the availability of computer based indication equipment is considered (e.g., SPDS, plant computer, etc.).]

"Planned" loss of annunciators or indicators includes scheduled maintenance and testing activities.

Quantification is arbitrary, however, it is estimated that if approximately 75% of the safety system annunciators or indicators are lost, there is an increased risk that a degraded plant condition could go undetected. It is not intended that plant personnel perform a detailed count of the instrumentation lost but use the value as a judgment threshold for determining the severity of the plant conditions. It is also not intended that the Shift Supervisor be tasked with making a judgment decision as to whether additional personnel are required to provide increased monitoring of system operation.

SYSTEM MALFUNCTIONS

It is further recognized that most plant designs provide redundant safety system indication powered from separate uninterruptible power supplies. While failure of a large portion of annunciators is more likely than a failure of a large portion of indications, the concern is included in this EAL due to difficulty associated with assessment of plant conditions. The loss of specific, or several, safety system indicators should remain a function of that specific system or component operability status. This will be addressed by the specific Technical Specification. The initiation of a Technical Specification imposed plant shutdown related to the instrument loss will be reported via 10 CFR 50.72. If the shutdown is not in compliance with the Technical Specification action, the NOUE is based on SU2 "Inability to Reach Required Shutdown Within Technical Specification Limits."

[Site-specific annunciators or indicators for this EAL must include those identified in the Abnormal Operating Procedures, in the Emergency Operating Procedures, and in other EALs (e.g., area, process, and/or effluent rad monitors, etc.).]

"Compensatory indications" in this context includes computer based information such as SPDS. *[This should include all computer systems available for this use depending on specific plant design and subsequent retrofits.]* If both a major portion of the annunciation system and all computer monitoring are unavailable, the Alert is required.

[Due to the limited number of safety systems in operation during cold shutdown, refueling and defueled modes, no IC is indicated during these modes of operation.]

Fifteen minutes was selected as a threshold to exclude transient or momentary power losses.

This Alert will be escalated to a Site Area Emergency if the operating crew cannot monitor the transient in progress due to a concurrent loss of compensatory indications with a SIGNIFICANT TRANSIENT in progress during the loss of annunciation or indication.

SYSTEM MALFUNCTIONS

SA5

Initiating Condition - ALERT

AC power capability to emergency busses reduced to a single power source for 15 minutes or longer such that any additional single failure would result in station blackout.

Operating Mode Applicability: Power Operation, Startup, Hot Standby, Hot Shutdown

Example Emergency Action Level:

Note: The Emergency Director should not wait until the applicable time has elapsed, but should declare the event as soon as it is determined that the condition has exceeded, or will likely exceed, the applicable time.

1. a. AC power capability to (site-specific emergency busses) reduced to a single power source for 15 minutes or longer.

AND

- b. Any additional single power source failure will result in station blackout.

Basis:

[This IC and the associated EALs are intended to provide an escalation from IC SU1, "Loss of All Off-site AC Power To Emergency Busses for Greater Than 15 Minutes."]

The condition indicated by this IC is the degradation of the off-site and on-site AC power systems such that any additional single failure would result in a station blackout. This condition could occur due to a loss of off-site power with a concurrent failure of all but one emergency generator to supply power to its emergency busses. Another related condition could be the loss of all off-site power and loss of on-site emergency generators with only one train of emergency busses being backfed from the unit main generator, or the loss of on-site emergency generators with only one train of emergency busses being backfed from off-site power. The subsequent loss of this single power source would escalate the event to a Site Area Emergency in accordance with SS1.

Fifteen minutes was selected as a threshold to exclude transient or momentary losses of power.

[At multi-unit stations, the EALs should allow credit for operation of installed design features, such as cross-ties or swing diesels, provided that abnormal or emergency operating procedures address their use. However, these stations must also consider the impact of this condition on other shared safety functions in developing the site specific EAL.]

[Plants that have a proceduralized capability to cross-tie AC power from an off-site power supply of a companion unit may take credit for the redundant power source in the associated EAL for this IC.]

SYSTEM MALFUNCTIONS

SS1

Initiating Condition - SITE AREA EMERGENCY

Loss of all Off-site and all On-Site AC power to emergency busses for 15 minutes or longer.

Operating Mode Applicability: Power Operation, Startup, Hot Standby, Hot Shutdown

Example Emergency Action Level:

Note: The Emergency Director should not wait until the applicable time has elapsed, but should declare the event as soon as it is determined that the condition has exceeded, or will likely exceed, the applicable time.

1. Loss of all Off-Site and all On-Site AC power to (site specific emergency busses) for 15 minutes or longer.

Basis:

Loss of all AC power to emergency busses compromises all plant safety systems requiring electric power including RHR, ECCS, Containment Heat Removal and the Ultimate Heat Sink. Prolonged loss of all AC power to emergency busses will lead to loss of Fuel Clad, RCS, and Containment, thus this event can escalate to a General Emergency.

Fifteen minutes was selected as a threshold to exclude transient or momentary losses of off-site power.

[At multi-unit stations, the EALs should allow credit for operation of installed design features, such as cross-ties or swing diesels, provided that abnormal or emergency operating procedures address their use. However, these stations must also consider the impact of this condition on other shared safety functions in developing the site specific EAL.]

[Plants that have a proceduralized capability to cross-tie AC power from an off-site power supply of a companion unit may take credit for the redundant power source in the associated EAL for this IC.]

Escalation to General Emergency is via Fission Product Barrier Degradation or IC SG1, "Prolonged Loss of All Off-site Power and Prolonged Loss of All On-site AC Power."

SYSTEM MALFUNCTIONS

SS2

Initiating Condition - SITE AREA EMERGENCY

Automatic Scram (Trip) fails to shutdown the reactor and manual actions taken from the reactor control console are not successful in shutting down the reactor.

Operating Mode Applicability: Power Operation, Startup

Example Emergency Action Level:

1. a. An automatic scram (trip) failed to shutdown the reactor.

AND
- b. Manual actions taken at the reactor control console do not shutdown the reactor as indicated by (site specific indications of reactor not shutdown).

Basis:

Under these conditions, the reactor is producing more heat than the maximum decay heat load for which the safety systems are designed and efforts to bring the reactor subcritical are unsuccessful. A Site Area Emergency is warranted because conditions exist that lead to IMMEDIATE loss or potential loss of both fuel clad and RCS.

[The reactor should be considered shutdown when it producing less heat than the maximum decay heat load for which the safety systems are designed (typically 3 to 5% power). For plants using CSFSTs, this EAL equates to the criteria used to determine a valid Subcriticality Red Path. For BWRs this EAL should be the APRM downscale trip setpoint.]

Manual scram (trip) actions taken at the reactor control console are any set of actions by the reactor operator(s) at which causes or should cause control rods to be rapidly inserted into the core and shuts down the reactor.

Manual scram (trip) actions are not considered successful if action away from the reactor control console is required to scram (trip) the reactor. This EAL is still applicable even if actions taken away from the reactor control console are successful in shutting the reactor down because the design limits of the fuel may have been exceeded or because of the gross failure of the Reactor Protection System to shutdown the plant.

[Although this IC may be viewed as redundant to the Fission Product Barrier Degradation IC, its inclusion is necessary to better assure timely recognition and emergency response.]

Escalation of this event to a General Emergency would be due to a prolonged condition leading to an extreme challenge to either core-cooling or heat removal.

SYSTEM MALFUNCTIONS

SS3

Initiating Condition - SITE AREA EMERGENCY

Loss of all vital DC power for 15 minutes or longer.

Operating Mode Applicability: Power Operation, Startup, Hot Standby, Hot Shutdown

Example Emergency Action Level:

Note: The Emergency Director should not wait until the applicable time has elapsed, but should declare the event as soon as it is determined that the condition has exceeded, or will likely exceed, the applicable time.

1. Less than (site specific bus voltage indication) on all (site specific Vital DC busses) for 15 minutes or longer.

Basis:

Loss of all DC power compromises ability to monitor and control plant safety functions. Prolonged loss of all DC power will cause core uncovering and loss of containment integrity when there is significant decay heat and sensible heat in the reactor system.

[Site specific bus voltage should be based on the minimum bus voltage necessary for the operation of safety related equipment. This voltage value should incorporate a margin of at least 15 minutes of operation before the onset of inability to operate those loads. This voltage is usually near the minimum voltage selected when battery sizing is performed. Typically the value for the entire battery set is approximately 105 VDC. For a 60 cell string of batteries the cell voltage is typically 1.75 Volts per cell. For a 58 string battery set the minimum voltage is typically 1.81 Volts per cell.]

Fifteen minutes was selected as a threshold to exclude transient or momentary power losses.

Escalation to a General Emergency would occur by Abnormal Rad Levels/Radiological Effluent, Fission Product Barrier Degradation.

SYSTEM MALFUNCTIONS

SS6

Initiating Condition - SITE AREA EMERGENCY

Inability to monitor a SIGNIFICANT TRANSIENT in progress.

Operating Mode Applicability: Power Operation, Startup, Hot Standby, Hot Shutdown

Example Emergency Action Level:

Note: The Emergency Director should not wait until the applicable time has elapsed, but should declare the event as soon as it is determined that the condition has exceeded, or will likely exceed, the applicable time.

1. a. Loss of greater than approximately 75% of the following for 15 minutes or longer:
 - (Site specific control room safety system annunciation)

OR

 - (Site specific control room safety system indication)

AND
- b. A SIGNIFICANT TRANSIENT is in progress.

AND
- c. Compensatory indications are unavailable.

Basis:

This IC is intended to recognize the threat to plant safety associated with the complete loss of capability of the control room staff to monitor plant response to a SIGNIFICANT TRANSIENT.

"Planned" and "UNPLANNED" actions are not differentiated since the loss of instrumentation of this magnitude is of such significance during a transient that the cause of the loss is not an ameliorating factor.

Quantification is arbitrary, however, it is estimated that if approximately 75% of the safety system annunciators or indicators are lost, there is an increased risk that a degraded plant condition could go undetected. It is not intended that plant personnel perform a detailed count of the instrumentation lost but use the value as a judgment threshold for determining the severity of the plant conditions. It is also not intended that the Shift Supervisor be tasked with making a judgment decision as to whether additional personnel are required to provide increased monitoring of system operation.

It is further recognized that most plant designs provide redundant safety system indication powered from separate uninterruptible power supplies. While failure of a large portion of annunciators is more likely than a failure of a large portion of indications, the concern is included in this EAL due to difficulty associated with assessment of plant conditions. The loss of specific,

SYSTEM MALFUNCTIONS

or several, safety system indicators should remain a function of that specific system or component operability status. This will be addressed by the specific Technical Specification. The initiation of a Technical Specification imposed plant shutdown related to the instrument loss will be reported via 10 CFR 50.72. If the shutdown is not in compliance with the Technical Specification action, the NOUE is based on SU2 "Inability to Reach Required Shutdown Within Technical Specification Limits."

A Site Area Emergency is considered to exist if the control room staff cannot monitor safety functions needed for protection of the public while a significant transient is in progress.

[Site specific annunciators for this EAL should be limited to include those identified in the Abnormal Operating Procedures, in the Emergency Operating Procedures, and in other EALs (.g., area, process, and/or effluent rad monitors, etc.)]

Site specific indications needed to monitor safety functions necessary for protection of the public must include control room indications, computer generated indications and dedicated annunciation capability.

[The specific indications should be those used to determine such functions as the ability to shut down the reactor, maintain the core cooled, to maintain the reactor coolant system intact, maintain the spent fuel cooled, and to maintain containment intact.]

"Compensatory indications" in this context includes computer based information such as SPDS. This should include all computer systems available for this use depending on specific plant design and subsequent retrofits.

Fifteen minutes was selected as a threshold to exclude transient or momentary power losses.

[Due to the limited number of safety systems in operation during cold shutdown, refueling and defueled modes, no IC is indicated during these modes of operation.]

SYSTEM MALFUNCTIONS

SG1

Initiating Condition - GENERAL EMERGENCY

Prolonged loss of all Off-site and all On-Site AC power to emergency busses.

Operating Mode Applicability: Power Operation, Startup, Hot Standby, Hot Shutdown

Example Emergency Action Level:

1. a. Loss of all off-site and all on-site AC power to (site specific emergency busses).
AND
- b. **EITHER** of the following:
 - Restoration of at least one emergency bus in less than (site specific hours) is not likely.
 - (Site specific indication of continuing degradation of core cooling based on Fission Product Barrier monitoring.)

Basis:

Loss of all AC power to emergency busses compromises all plant safety systems requiring electric power including RHR, ECCS, Containment Heat Removal and the Ultimate Heat Sink. Prolonged loss of all AC power to emergency busses will lead to loss of fuel clad, RCS, and containment, thus warranting declaration of a General Emergency.

[The (site-specific hours) to restore AC power can be based on a site blackout coping analysis performed in conformance with 10 CFR 50.63 and Regulatory Guide 1.155, "Station Blackout," as available. Appropriate allowance for off-site emergency response including evacuation of surrounding areas should be considered. Although this IC may be viewed as redundant to the Fission Product Barrier Degradation IC, its inclusion is necessary to better assure timely recognition and emergency response.]

This IC is specified to assure that in the unlikely event of a prolonged station blackout, timely recognition of the seriousness of the event occurs and that declaration of a General Emergency occurs as early as is appropriate, based on a reasonable assessment of the event trajectory.

The likelihood of restoring at least one emergency bus should be based on a realistic appraisal of the situation since a delay in an upgrade decision based on only a chance of mitigating the event could result in a loss of valuable time in preparing and implementing public protective actions.

In addition, under these conditions, fission product barrier monitoring capability may be degraded.

SYSTEM MALFUNCTIONS

[Although it may be difficult to predict when power can be restored, it is necessary to give the Emergency Director a reasonable idea of how quickly (s)he may need to declare a General Emergency based on two major considerations:

- 1. Are there any present indications that core cooling is already degraded to the point that loss or potential loss of Fission Product Barriers is IMMINENT?*
- 2. If there are no present indications of such core cooling degradation, how likely is it that power can be restored in time to assure that a loss of two barriers with a potential loss of the third barrier can be prevented?*

Thus, indication of continuing core cooling degradation must be based on Fission Product Barrier monitoring with particular emphasis on Emergency Director judgment as it relates to IMMINENT loss or potential loss of fission product barriers and degraded ability to monitor fission product barriers.]

SYSTEM MALFUNCTIONS

SG2

Initiating Condition - GENERAL EMERGENCY

Automatic Scram (Trip) and all manual actions fail to shutdown the reactor and indication of an extreme challenge to the ability to cool the core exists.

Operating Mode Applicability: Power Operation, Startup

Example Emergency Action Level:

1. a. An automatic scram (trip) failed to shutdown the reactor.
AND
- b. All manual actions do not shutdown the reactor as indicated by (site specific indications of reactor not shutdown).
AND
- c. **EITHER** of the following exist or have occurred due to continued power generation:
 - (Site specific indication that core cooling is extremely challenged.)
 - (Site specific indication that heat removal is extremely challenged.)

Basis:

Under these conditions, the reactor is producing more heat than the maximum decay heat load for which the safety systems are designed and efforts to bring the reactor subcritical are unsuccessful.

[The reactor should be considered shutdown when it producing less heat than the maximum decay heat load for which the safety systems are designed (typically 3 to 5% power). For plants using CSFSTs, this EAL equates to the criteria used to determine a valid Subcriticality Red Path. For BWRs this EAL should be the APRM downscale trip setpoint.]

[For PWRs, the extreme challenge to the ability to cool the core is intended to mean that the core exit temperatures are at or approaching 1200 degrees F or that the reactor vessel water level is below the top of active fuel. For plants using CSFSTs, this EAL equates to a Core Cooling RED condition combined with a Subcriticality RED condition.]

[For BWRs, the extreme challenge to the ability to cool the core is intended to mean that the reactor vessel water level cannot be restored and maintained above Minimum Steam Cooling RPV Water Level as described in the EOP bases.]

[Another consideration is the inability to initially remove heat during the early stages of this sequence. For PWRs, if emergency feedwater flow is insufficient to remove the amount of heat required by design from at least one steam generator, an extreme challenge should be

SYSTEM MALFUNCTIONS

considered to exist. For plants using CSFSTs, this EAL equates to a Heat Sink RED condition combined with a Subcriticality RED condition.]

[For BWRs, considerations include inability to remove heat via the main condenser, or via the suppression pool or torus (e.g., due to high pool water temperature).]

In the event either of these challenges exists at a time that the reactor has not been brought below the power associated with the safety system design a core melt sequence exists. In this situation, core degradation can occur rapidly. For this reason, the General Emergency declaration is intended to be anticipatory of the fission product barrier table declaration to permit maximum off-site intervention time.

Appendix A: Basis for Radiological Effluent EALs

Introduction

This appendix supplements the basis information provided in Section 5 for initiating conditions AU1, AA1, AS1, and AG1. Since the publication of revision 2 of this methodology, there have been numerous questions raised as utilities worked to implement the IC and EALs. Additional feedback was provided by the staff of the Nuclear Regulatory Commission. It became apparent that the brief basis provided for each IC was not sufficient. When revision 3 of this document was in preparation, it was decided to incorporate this appendix to provide the needed additional guidance and clarification. The NUMARC/NESP-007 effluent IC/EALs represent a departure from previous EAL practice and understanding these differences and their technical bases will facilitate site specific implementation of the NUMARC/NESP-007 classification methodology.

This appendix will be structured into seven major sections. They are:

1. Purpose of the effluent ICs/EALs and their relationship to other ICs/EALs
2. Explanation of the ICs
3. Explanation of the example EALs and their relationship to the ICs
4. Interface between the ICs/EALs and the Off-site Dose Calculation Manual (ODCM)
5. Monitor setpoints versus EALs.
6. The impact of meteorology
7. The impact of source term

A.1 Purpose of the Effluent ICs/EALs

ICs AU1, AA1, AS1, and AG1 provide classification thresholds for UNPLANNED and/or uncontrolled releases of radioactivity to the environment. In as much as the purpose of emergency planning at nuclear power plants is to minimize the consequences of radioactivity releases to the environment, these ICs would appear to be controlling. However, classification of emergencies on the basis of radioactivity releases is not optimum, particularly those classifications based on radiation monitor indications. Such classifications can be deficient for several reasons, including:

- In significant emergency events, a radioactivity release is seldom the initiating event, but rather, is the consequence of some other condition. Relying on an indication of a release may not be sufficiently anticipatory.
- The relationship between an effluent monitor indication caused by a release and the off-site conditions that result is a function of several parameters (e.g., meteorology, source term) which can change in value by orders of magnitude between normal and emergency conditions and from event to event. The appropriateness of these classifications is dependent on how well the parameter values assumed in pre-establishing the classification thresholds match those that are present at the time of the incident.

Section 3.3 of NUMARC/NESP-007 emphasizes the need for accurate assessment and classification of events, recognizing that over-classification, as well as under-classification, is to be avoided. Primary emphasis is intended to be placed on plant conditions in classifying emergency events. Effluent ICs were included, however, to provide a basis for classifying events that cannot be readily classified on the basis of plant condition alone. Plant condition ICs are included to address the precursors to radioactivity release in order to ensure anticipatory action. The effluent ICs do not stand alone, nor do the plant condition ICs. The inclusion of both categories more fully addresses the potential event spectrum and compensates for potential deficiencies in either. This is a case in which the whole is greater than the sum of the parts.

From the discussion that follows, it should become clear how the various aspects of the NUMARC/NESP-007/NEI 99-01 effluent ICs/EALs work together to provide for reasonably accurate and timely emergency classifications. While some aspects of the radiological effluent EALs may appear to be potentially unconservative, one also needs to consider IC/EALs in other recognition categories that compensate for this condition. During site specific implementation of these ICs/EALs, changes to some of these aspects might appear advantageous. While site specific changes are anticipated, caution must be used to ensure that these changes do not impact the overall effectiveness of the ICs / EALs.

A.2 Initiating Conditions

There are four radiological effluent ICs provided in NUMARC/NESP-007. The IC and the fundamental basis for the ultimate classification for the four classifications are:

GE (AG1)	Off-site Dose Resulting from an Actual or IMMEDIATE Release of Gaseous Radioactivity Exceeds 1000 mrem TEDE or 5000 mem Thyroid CDE for the Actual or Projected Duration of the Release Using Actual Meteorology.
SAE (AS1)	Off-site Dose Resulting from an Actual or IMMEDIATE Release of Gaseous Radioactivity Exceeds 100 mrem TEDE or 500 mrem Thyroid CDE for the Actual or Projected Duration of the Release.
Alert (AA1)	Any Release of Gaseous or Liquid Radioactivity to the Environment that Exceeds 200 Times Radiological Technical Specifications for 15 Minutes or Longer.
NOUE (AU1)	Any Release of Gaseous or Liquid Radioactivity to the Environment that Exceeds Two Times Radiological Technical Specifications for 60 Minutes or Longer.

The fundamental basis of AU1 and AA1 ICs differs from that for AS1 and AG1 ICs. It is important to understand the differences.

- The Radiological Effluent Technical Specifications (RETS) (similar controls are included in the ODCMs of those facilities that implemented Generic Letter 89-01) are associated with particular off-site doses and dose rate limits. For showing compliance with these limits, facility Off-site Dose Calculation Manuals (ODCM) establish methodologies for establishing effluent monitor alarm setpoints, based on defined source term and meteorology assumptions.
- AU1 and AA1 are **NOT** based on these particular values of off-site dose or dose rate but, rather, on the loss of plant control implied by a radiological release that exceeds a specified multiple of the ODCM release limits for a specified period of time.

- The ODCM multiples are specified only to distinguish AU1 and AA1 from non-emergency conditions and from each other. While these multiples obviously correspond to an off-site dose, the classification emphasis is on a release that does not comply with a license commitment for an extended period of time.
- While some of the example EALs for AU1 and AA1 use indications of off-site dose rates as **symptoms** that the ODCM may be exceeded, the IC, and the classification, are **NOT** concerned with the particular value of off-site dose. While there may be quantitative inconsistencies involved with this protocol, the qualitative basis of the EAL, i.e., loss of plant control, is not affected.
- The basis of the AS1 and AG1 ICs **IS** a particular value of off-site dose for the event duration. AG1 is set to the value of the EPA PAG. AS1 is a fraction (10%) of the EPA PAG. As such, these ICs are consistent with the fundamental definitions of a Site Area and General Emergency.

A.3 Example Emergency Action Levels

For each of the classifications, NUMARC/NESP-007 provides some example emergency action levels and bases. Ideally, the example EALs would correspond numerically with the thresholds expressed in the respective IC. Two cases are applicable to the effluent EALs:

1. The EAL corresponds numerically to the threshold in the respective IC. For example, a field survey result of 1000 mrem/hr for a projected condition of one hour corresponds directly to AG1.
2. The EAL corresponds numerically to the threshold in the respective IC under certain assumed conditions. For example, an effluent monitor reading that equates to 100 mrem for the projected duration of the release corresponds numerically to AS1 *if* the actual meteorology, source term, and release duration matches that used in establishing the monitor thresholds.

There are four typical example EALs:

- Effluent Monitor Readings: These EALs are pre-calculated values that correspond to the condition identified in the IC for a given set of assumptions.
- Field Survey Results: These example EALs are included to provide a means to address classifications based on results from field surveys.
- Perimeter Monitor Indications: For sites having them, perimeter monitors can provide a direct indication of the off-site consequences of a release.
- Dose Assessment Results: These example EALs are included to provide a means to address classifications based on dose assessments.

A.3.1 Effluent Monitor Readings

As noted above, these EALs are pre-calculated values that correspond to the condition identified in the IC for a given set of assumptions. The degree of correlation is dependent on how well the assumed parameters (e.g., meteorology, source term, etc.) represent the actual parameters at the time of the emergency.

AS1 and AG1

Classifications should be made under these EALs if VALID (e.g., channel check, comparison to redundant/diverse indication, etc.) effluent radiation monitor readings exceed the pre-calculated thresholds. In a change from previous versions of this methodology, confirmation by dose

assessments is no longer required as a prerequisite to the classification. Nonetheless, dose assessments are important components of the overall accident assessment activities when significant radioactivity releases have occurred or are projected. Dose assessment results, when they become available, may serve to confirm the validity of the effluent radiation monitor EAL, may indicate that an escalation to a higher classification is necessary, or may indicate that the classification wasn't warranted. AS1 and AG1 both provide that, if dose assessment results are available, the classification should be based on the basis of the dose assessment result rather than the effluent radiation monitor EAL.

AU1 and AA1

ODCMs provide a methodology for determining default and batch-specific effluent monitor alarm setpoints pursuant to Standard Technical Specification (STS) 3.3.3.9. These setpoints are intended to show that releases are within STS 3.11.2.1. The applicable limits are 500 mrem/year whole body or 3000 mrem/year skin from noble gases. (Inhalation dose rate limits are not addressed here since the specified surveillance involves collection and analysis of composite samples. This after-the-fact assessment could not be made in a timely manner conducive to accident classification.) These setpoints are calculated using default source terms or batch-specific sample isotopic results and annual average χ/Q . Since the meteorology data is pre-defined, there is a direct correlation between the monitor setpoints and the ODCM limits. Although the actual χ/Q may be different, NUREG-1022, Event Reporting Guidelines 10 CFR 50.72 and 50.73, provided "*..Annual average meteorological data should be used for determining off-site airborne concentrations of radioactivity to maintain consistency with the technical specifications (TS) for reportability thresholds.*" The ODCM methodology is based on long term continuous releases. However, its use here in a short term release situation is appropriate. Remember that the AU1 and AA1 ICs are based on a loss of plant control indicated by the failure to comply with a multiple of the ODCM release limits for an extended period and that the ODCM provides the methodology for showing compliance with the ODCM.

To obtain the thresholds, multiply the ODCM setpoint for each monitor by 2 (AU1) or 200 (AA1). It would be preferable to reference "*2 x ODCM Setpoint*" or "*200 x ODCM Setpoint*" as the threshold. In this manner, the EAL would always change in step with changes in the ODCM setpoint (e.g., for a batch or special release. In actual practice, there may be a "warning" and a "high" alarm setpoint. The setpoint that is closest in value to the ODCM limit should be used. Facility ODCMs may lower the actual setpoint to provide an administrative "safety margin". Also, if there is more than one unit or release stack on the site, the ODCM limits may be apportioned. Two possible approaches to obtain the thresholds are:

- The "2x" and "200x" multiples could be increased to address the reduced setpoints. For example, if the stack monitor was set to 50% of the ODCM limit, the threshold could be set to "4x" and "400x" the setpoint on that monitor.
- The reduced setpoints could be ignored and the "2x" and "200x" multiples used as specified. While numerically conservative, using a single set of multipliers would probably be desirable from a human engineering standpoint.

In a change from previous versions of this methodology, confirmation by dose assessments is no longer required as a prerequisite to the classification. While assessments with real meteorology may have provided a basis for escalating to AS1 (or AG1), the assessments could not confirm the AU1 or AA1 classifications since compliance with the ODCM is demonstrated using *annual average* meteorology – not actual meteorology.

Nonetheless, dose assessments are important components of the overall accident assessment activities when significant radioactivity releases have occurred or are projected. Dose

assessment results, when they become available, may indicate that an escalation to a higher classification is necessary. AS1 and AG1 both provide that, if dose assessment results are available, the classification should be based on the basis of the dose assessment result rather than the effluent radiation monitor EAL.

In typical practice, the radiological effluent monitor alarms would have been set, on the basis of ODCM requirements, to indicate a release that could exceed the ODCM limits. Alarm response procedures call for an assessment of the alarm to determine whether or not ODCM limits have been exceeded. Utilities typically have methods for rapidly assessing an abnormal release in order to determine whether or not the situation is reportable under 10 CFR 50.72. Since a radioactivity release of a magnitude comparable to the ODCM limits will not create a need for off-site protective measures, it would be reasonable to use these abnormal release assessment methods to initiate dose assessment techniques using actual meteorology and projected source term and release duration.

A.3.2 Perimeter Monitor, Field Survey Results, Dose Projection Results

AS1 and AG1

The perimeter monitor and field survey results are included to provide a means for classification based on actual measurements. There is a 1:1 correlation (with consideration of release duration) between these EALs and the IC since all are dependent on actual meteorology.

Dose projection result EALs are included to provide a basis for classification based on results from assessments triggered at lower emergency classifications. If the dose assessment results are available at the time that the classification is made, the results should be used in conjunction with this EAL for classifying the event rather than the effluent radiation monitor EAL.

Although the IC references TEDE and thyroid CDE as criteria, field survey results and perimeter monitor indications will generally not be reported in these dose quantities, but rather in terms of a dose rate. For this reason, the field survey EALs are based on a β - γ dose rate and a thyroid CDE value, both assuming one hour of exposure (or inhalation). If individual site analyses indicate a longer or shorter duration for the period in which the substantial portion of the activity is released, the longer duration should be used for the field survey and/or perimeter monitor EALs.

AU1 and AA1

As discussed previously, the threshold in these ICs is based on exceeding a multiple of the ODCM for an extended period. The applicable ODCM limit is the instantaneous dose rate provided in Standard Technical Specification (STS) 3.11.2.1. While these three EALs are also expressed in dose rate, they are dependent on *actual* meteorology. However, compliance with the ODCM is demonstrated using *annual average* meteorology. Due to this, the only time that there would be a 1:1 correlation between the IC and these EALs is when the value of the actual meteorology matched the annual average - an unlikely situation. For this reason, these EALs can only be indirect indicators that the ODCM may be exceeded. The three example EALs are consistent with the fundamental basis of AU1 and AA1, that of a uncontrolled radioactivity release that indicates a loss of plant control. A dose rate, at or beyond the site boundary, greater than 0.1 mR/hr for 60 minutes or 10.0 mR/hr for 15 minutes is consistent with this fundamental basis, regardless of the lack of numerical correlation to the ODCM. The time periods chosen for the NOUE AU1 (60 minutes) and Alert AA1 (15 minutes) are indicative of the relative risks based on the loss of ability to terminate a release.

The numeric values shown in AU1 and AA1 are based on a release rate not exceeding 500 mrem per year, converted to a rate of: $500 \div 8766 = 0.057$ mR/hr. If we take a multiple of 2, as specified in the NOUE threshold, this equates to a dose rate of about 0.11 mR/hr, which rounds to the 0.1 mR/hr specified in AU1. Similarly for the AA1 EALs, we obtain 10 mR/hr.

In AU1 and AA1, reference is made to *automatic real-time dose assessment capability*. In AS1 and AG1, the reference is to *dose assessment*. This distinction was made since it is unlikely that a dose assessment using manual methods would be initiated without some prior indication, e.g., a effluent monitor EAL.

A.4 Interface Between ODCM and ICs/EALs

For AU1 and AA1, a strong link was established with the facility's ODCM. It was the intent of the NUMARC/NESP EAL Task Force to have the AU1 and AA1 EALs indexed to the ODCM alarm setpoints. This was done for several reasons:

- To allow the EALs to use the monitor setpoints already in place in the facility ODCM, thus eliminating the need for a second set of values as the EALs. The EAL could reference "2x ODCM Setpoint" or "200x ODCM Setpoint" for the monitors addressed in the ODCM. Extensive calculations would only be necessary for monitors not addressed in the ODCM.
- To take advantage of the alarm setpoint calculational methodology already documented in the facility ODCM.
- To ensure that the operators had an alarm to indicate the abnormal condition. If the monitor threshold was less than the default ODCM setpoint, the operators could be in the position of having exceeded an EAL and not knowing it.
- To simplify the IC/EAL by eliminating the need to address planned and UNPLANNED releases, continuous or batch releases, monitored or unmonitored releases. Any release that complies with the radiological effluent technical specifications (RETS) (or ODCM controls for utilities that have implemented GL 89-01) would not exceed a monitor threshold.
- To eliminate the possibility of a planned release (e.g., containment / primary containment purge) resulting in effluent radiation monitor readings that exceed a classification threshold that was based on a different calculation method. ODCMs typically require specific alarm setpoints for such releases. If the release can be authorized under the provisions of the ODCM/RETS, an emergency classification is not warranted. If the monitor threshold is indexed to the ODCM setpoint (e.g., "...2 x ODCM setpoint...") the monitor EAL will always change in step with the ODCM setpoint.
- Although the ODCM addresses long term routine releases, its use here for short term releases is appropriate. The IC is specified in terms of a release that exceeds ODCM for an extended period of time. Compliance to the ODCM is shown using the ODCM methodology.

A.5 Setpoints versus Monitor EALs

Effluent monitors typically have provision for two separate alarm setpoints associated with the level of measured radioactivity. (There may be other alarms for parameters such as low sample flow.) These setpoints are typically established by the facility ODCM. As such, at most sites the values of the monitor thresholds will not be implemented as actual alarm setpoints, but would be tabulated in the classification procedure. If the monitor thresholds are calculated as suggested herein they will be higher than the ODCM alarm setpoints by at least a factor of two (i.e., AU1). This alarm alerts the operator to compare the monitor indication to the thresholds. The NUMARC/NESP-007 effluent EALs do NOT require alarm setpoints based on the monitor EALs. However, if spare alarm channels are available (e.g., high range channels), the monitor threshold could be used as the alarm setpoint.

A.6 The Impact of Meteorology

The existence of uncertainty between actual event meteorology and the meteorology assumed in establishing the EALs was identified above. It is important to note that uncertainty is present regardless of the meteorology data set assumed. The magnitude of the potential difference and, hence, the degree of conservatism will depend on the data set selected. Data sets that are intended to ensure low probability of under-conservative assessments have a high probability of being over-conservative. For nuclear power plants, there are different sets of meteorological data used for different purposes. The two primary sets are:

- For accident analyses purposes, sector χ/Q values are set at that value that is exceeded only 0.5% of the hours wind blows into the sector. The highest of the 16 sector values is the maximum sector χ/Q value. The site χ/Q value is set at that value that is exceeded only 5% of the hours for all sectors. The higher of the sector or site χ/Q values is used in accident analyses.
- For routine release situations, annual average χ/Q values are calculated for specified receptor locations and at standard distances in each of the 16 radial sectors. In setting ODCM alarm set points, the annual average χ/Q value for the most restrictive receptor at or beyond the site boundary is used. The sector annual average χ/Q value is normalized for the percentage of time that the wind blows into that sector. In an actual event, the wind direction may be into the affected sector for the entire release duration. Many sites experience typical sector χ/Q s that are 10-20 times higher than the calculated annual average for the sector.

In developing the effluent EALs, the NUMARC EAL Task Force elected to use annual average meteorology for establishing effluent monitor thresholds. This decision was based on the following considerations.

- Use of the accident χ/Q s, may be too conservative. For some sites, the difference between the accident χ/Q and the annual average χ/Q can be a factor of 100-1000. With this difference in magnitude, the calculated monitor EALs for AS1 or AG1 might actually be less than the ODCM alarm setpoints, resulting in unwarranted classifications for releases that might be in compliance with ODCM limits.
- The ODCM is based in part on annual average χ/Q (non-normalized). ODCMs already provide alarm setpoints based on annual average χ/Q that could be used for AU1 and AA1.
- Use of a χ/Q more restrictive than the χ/Q used to establish ODCM alarm setpoints could create a situation in which the EAL value would be less than the ODCM setpoint. In this case, the operators would have no alarm indication to alert them of the emergency condition.
- Use of one χ/Q value for AU1 and AA1 and another for AS1 and AG1 might result in monitor EALs that would not progress from low to high classifications. Instead, the AS1 and AA1 EALs might overlap.

Plant specific consideration must be made to determine if annual average meteorology is adequately conservative for site specific use. If not one of the two more conservative techniques described above should be selected. It is incumbent upon the licensee to ensure that the selection is properly implemented to provide consistent classification escalation.

The impact of the differences between the assumed annual average meteorology and the actual meteorology depends on the particular EAL.

- For the AU1 and AA1 effluent monitor EALs, there is no impact since the IC and the EALs are based on annual average meteorology by definition.
- For the field survey, perimeter monitor, and dose assessment results EALs in AS1 and AG1, there is no impact since the IC and these EALs are based on actual meteorology.
- For the AS1 and AG1 effluent monitor EALs, there may be differences since the IC is based on actual meteorology and the monitor EALs are calculated on the basis of annual average meteorology or, on a site specific basis, one of the more conservative derivatives of annual average meteorology. This is considered as acceptable in that dose assessments using actual meteorology will be initiated for significant radioactivity releases. Needed escalations can be based on the results of these assessments. As discussed previously, this delay was deemed to be acceptable since in significant release situations, the plant condition EALs should provide the anticipatory classifications necessary for the implementation of off-site protective measures.
- For the field survey, perimeter monitor, and dose assessment results EALs in AU1 and AA1, there is an impact. These three EALs are dependent on actual meteorology. However, the threshold values for all of the AU1 and AA1 EALs are based on the assumption of annual average meteorology. If the actual and annual average meteorology were equal, the IC and all of the EALs would correlate. Since it is likely that the actual meteorology will exceed the annual average meteorology, there will be numerical inconsistencies between these EALs and the IC. The three example EALs are consistent with the fundamental basis of AU1 and AA1, that of a uncontrolled radioactivity release that indicates a loss of plant control. A dose rate, at or beyond the site boundary, greater than 0.1 mR/hr for 60 minutes or 10.0 mR/hr for 15 minutes is consistent with this fundamental basis, regardless of the lack of numerical correlation to the ODCM.

A.7 The Impact of Source Term

The ODCM methodology should be used for establishing the monitor thresholds for these ICs. The ODCM provides a default source term based on expected releases. In many cases, the ODCM source term is derived from expected and/or design releases tabulated in the FSAR.

For AS1 and AG1, the bases suggests the use of the same source terms used for establishing monitor thresholds for AU1 and AA1, or an accident source term if deemed appropriate. This guidance is provided to promote proper escalations, use realistic values, and correlation between rad monitor values and dose assessment results. Other source terms may be appropriate to achieve these goals. In any case, efforts should be made to obtain and use best estimate (For Example: NUREG 1465), as opposed to conservative, source terms for all four ICs.

Even if the same source term is used for all four ICs, the analyst must consider the impact of overly conservative iodine to noble gas ratios. The AU1 and AA1 IC thresholds are based on external noble gas exposure. The AS1 and AG1 ICs are based on either TEDE or thyroid CDE. TEDE includes a contribution from inhalation exposure (i.e., CEDE) while the thyroid CDE is due solely to inhalation exposure. The inhalation exposure is sensitive to the iodine concentration in the source term. Since AU1 and AA1 are based on noble gases, and AS1 and AG1 are dependent on noble gases and iodine, an over conservative iodine to noble gas ratio could result in AS1 and AG1 monitor thresholds that either overlap or are too close to the AA1 monitor thresholds.

As with meteorology, assessment of source terms has uncertainty. This uncertainty is compensated for by the anticipatory classifications provided by ICs in other recognition categories.

Appendix D: Basis for Permanently Defueled Station EALs

Introduction

Recognition Category D was written to provide a stand alone set of IC/EALs for Permanently Defueled Stations. IC/EALs from Recognition Category A, C, F, S, and H were reviewed and where applicable have been included to address all Permanently Defueled station events.

A Permanently Defueled station is basically a spent fuel storage facility. This appendix is based on the assumption that the spent fuel was generated by an operating nuclear power station under a 10 CFR50 license that has ceased operations and intends to store the spent fuel for some period of time. The spent fuel is stored in a pool of water that serves as both the cooling medium for decay heat and shielding from direct radiation. The primary functions of this pool configuration become the emphasis of emergency classification methodology.

When in the permanently defueled condition, the licensee receives approval for exemption from specific emergency planning requirements. These exemptions must be approved by the NRC. The source term and relative risks associated with pool storage are the basis for maintaining only an on-site emergency plan. Calculations are provided in the licensing process that quantify radioactive releases associated with plausible accidents as documented in the stations Safety Analysis Report (SAR).

D.1 Purpose of the Permanently Defueled ICs/EALs

The emergency classification levels used are those provided by NUREG-0654/FEMA-REP-1. The NOUE emergency classification levels provide an increased awareness for abnormal conditions. The Alert emergency classification levels are specific to the actual or potential effects on the spent fuel in storage. The source term and motive force available in the permanently defueled condition is insufficient to warrant Site Area Emergency or General Emergency classification levels. Analyses for the credible design basis accidents are provided in the SAR.

Section 3.3 of NUMARC/NESP-007 emphasizes the need for accurate assessment and classification of events, recognizing that over-classification, as well as under-classification, is to be avoided. Primary emphasis is intended to be placed on observable conditions in classifying emergency events. In the permanently defueled condition, these conditions are primarily associated with the spent fuel, the spent fuel pool systems used to provide cooling, and shielding. Effluent IC/EALs were included, however, to provide a basis for classifying events that cannot be readily classified based on observable condition alone.

D.2 Initiating Conditions

There are two radiological effluent IC/EALs provided. The IC/EALs and the fundamental basis for classifications are:

Alert (D-AA1)	Any release of gaseous or liquid radioactivity to the environment greater than 200 times the Radiological Effluent Technical Specification for 15 minutes or longer.
NOUE (D-AU1)	Any release of gaseous or liquid radioactivity to the environment greater than 2 times the Radiological Effluent Technical Specification for 60 minutes or longer.

D-AU1 and D-AA1 are **NOT** based on these particular values of off-site dose or dose rate but, rather, on the loss of plant control implied by a radiological release that exceeds a specified multiple of the ODCM release limits for a specified period of time.

IC/EALs D-AU1 and D-AA1 provide classification thresholds for releases of radioactivity to the environment. Calculations supporting the release rates specified in the EAL values should be provided which quantify expected doses at the Restricted Area Boundary. The major isotope of concern in the permanently defueled condition is Kr-85.

Alert (D-AA2) UNPLANNED rise in plant radiation levels that impedes plant access required to maintain spent fuel integrity.

NOUE (D-AU2) UNPLANNED rise in plant radiation levels.

IC/EALs D-AU2 and D-AA2 provide classification thresholds for UNPLANNED increases of radiation levels. These IC/EALs are concerned with increases in radiation levels within the facility that may affect operations. The Alert IC/EAL is specific to areas that will result in exposure to plant personnel. An increase of 100 mR/hr must also be accompanied by some impeded operations. The 100 mR/hr is arbitrary and may be set at a reasonable value for a specific application with justification for that value provided. The value of 15 mR/hr is derived from the GDC 19 value of 5 Rem in 30 days with adjustment for expected occupancy times. Although Section III.D.3 of NUREG-0737, "*Clarification of TMI Action Plan Requirements*", provides that the 15 mR/hr value can be averaged over the 30 days, the value is used in this threshold without averaging, as a 30 day duration implies an event potentially more significant than an Alert. The NOUE uses a moderate increase in monitored radiation level that is not the result of a planned evolution and the source of the increase is not immediately recognized and controlled. The value selected (25 mR/hr) is arbitrary and may be set at a reasonable value for a specific application with justification for that value provided. This IC/EAL is included to raise awareness of an abnormal condition.

One system malfunction is provided that is directly related to the permanently defueled condition methodology. The Spent Fuel pool inventory and temperature are the primary parameters that indicate the potential for fuel damage.

NOUE (D-SU1) UNPLANNED Spent Fuel Pool temperature rise.

The Site Specific value for decreasing level should be based on either the Technical Specification value for Spent Fuel Pool level or a calculated level that will result in prohibitive radiation levels in the Fuel Building. Justification for the level used in the EAL value should allow for time to correct the level decrease prior to classification.

The site-specific temperature should be chosen based on the starting point for fuel damage calculations in the SAR. Typically, this temperature is 125° to 150° F. Spent Fuel Pool temperature is normally maintained well below this point thus allowing time to correct the cooling system malfunction prior to classification.

It is assumed that the level and temperature thresholds described above result from an UNPLANNED evolution. The NOUE is thus used to heighten awareness of control problems associated with spent fuel pool inventory or temperature control. Both of these conditions would have a long lead-time before fuel damage could occur due to decay heat.

Alert (D-HA1) HOSTILE ACTION within the fuel building or control room.

Appendix D:

Basis for Permanently Defueled Station EALs

NOUE (D-HU1) Confirmed SECURITY CONDITION or threat which indicates a potential degradation in the level of safety of the plant.

A confirmed INTRUSION report is satisfied if physical evidence indicates the presence of a HOSTILE FORCE within the Fuel Handling Building or control room. An Alert classification is warranted to account for the potential fuel damage that may be inflicted by a HOSTILE FORCE.

The NOUE is based on site specific Site Security Plans. Security events that do not represent a potential degradation in the level of safety of the plant are reported under 10 CFR 73.71 or in some cases under 10 CFR 50.72.

Reference is made to site specific security shift supervision because these individuals are the designated personnel on-site qualified and trained to confirm that a security event is occurring or has occurred. Training on security event classification confirmation is closely controlled due to the strict secrecy controls placed on the plant Security Plan.

Alert (D-HA2) Other conditions exist which in the judgment of the Emergency Director warrant declaration of an ALERT.

NOUE (D-HU2) Other conditions exist which in the judgment of the Emergency Director warrant declaration of an UNUSUAL EVENT.

The Emergency Director has the discretion to classify events based on the classification level definitions. This discretion should be used when conditions or events are observed and no specific IC/EAL is apparent. A discretionary Alert will provide the onshift crew with additional personnel to address the abnormal condition. The NOUE will heighten awareness of the abnormal condition.

NOUE (D-HU3) Natural or destructive phenomena inside the PROTECTED AREA affecting the ability to maintain spent fuel integrity.

Natural or Destructive phenomena are classified at the NOUE level because of the unknown factors of the effects when they occur. Escalation to an Alert is through the observable effects of the Natural or Destructive phenomena via D- AA2.

Appendix E: Basis for ISFSI EALs

Introduction

An Independent Spent Fuel Storage Installation (ISFSI) is a complex that is designed and constructed for the interim storage of spent nuclear fuel and other radioactive materials associated with spent fuel storage. An ISFSI which is located on the site of another facility may share common utilities/services and be physically connected with the other facility yet still be considered independent provided, that such sharing of utilities and services or physical connections does not: (1) Increase the probability or consequences of an accident or malfunction of components, structures, or systems that are important to safety; or (2) reduce the margin of safety as defined in the basis for any technical specification of either facility.

A Dry Cask Storage System (DCSS) may be used to store spent nuclear fuel under either a site-specific or general license to operate an ISFSI. At present, any holder of an active reactor operating license under 10 CFR Part 50, has the authority to construct and operate an ISFSI under the provisions of the general license. Requirements for construction and pre-operational activities of such an ISFSI are discussed in Subparts K and L of 10 CFR Part 72. The requirements for pursuing a site-specific ISFSI license are discussed in Subparts B and C of 10 CFR Part 72.

E.1 Purpose of the ISFSI IC/EALs

The analysis of potential on-site and off-site consequences of accidental releases associated with the operation of an ISFSI is contained in NUREG-1140, A Regulatory Analysis on Emergency Preparedness for Fuel Cycle and Other Radioactive Material Licensees. NUREG-1140 concluded that the postulated worst-case accident involving an ISFSI has insignificant consequences to the public health and safety. This evaluation shows that the maximum off-site dose to a member of the public off-site due to an accidental release of radioactive materials would not exceed 1 rem effective dose equivalent or an intake of 2 milligrams of soluble uranium (due to chemical toxicity).

The Final Rule governing Emergency Planning Licensing Requirements for Independent Spent Fuel Storage Facilities was posted in the Federal Register on June 22, 1995 (Federal Register Volume 60, Number 120 June 22, 1995, Pages 32430-32442). The rule indicated that a significant amount of the radioactive material contained within a cask must escape its packaging and enter the atmosphere for there to be a significant environmental impact resulting from an accident involving the dry storage of spent nuclear fuel. There are two primary factors that protect the public health and safety from this unlikely dry storage radioactive material release event.

The first deals with regulatory requirements imposed on the design for the cask. Regulatory requirements have sufficient safety margins so that (during normal storage cask handling operations, off-normal events, adverse environmental conditions, and severe natural phenomena) the casks cannot release a significant part of its inventory to the atmosphere.

The second factor deals with the cask general design criteria. The cask criteria requires that 1) design provides confinement safety functions during the unlikely but credible design basis events, 2) the fuel clad must be protected against degradation that leads to gross rupture, and 3) the fuel must be retrievable. These general design criteria place an upper bound on the energy a cask can absorb before the fuel is damaged. No credible dynamic events were identified that could impart such significant amounts of energy to a storage cask after that cask is placed at the ISFSI. The second factor also considers the lack of dispersal mechanisms and

the age of the spent fuel. There is no significant dispersal mechanism for the radioactive material contained within a storage cask. Spent fuel required to be stored in an ISFSI must be cooled for at least 1 year. Based on the design limitations of most cask systems, the majority of spent fuel is cooled greater than 5 years. At this age, spent fuel has a heat generation rate that is too low to cause significant particulate dispersal in the unlikely event of a cask CONFINEMENT BOUNDARY failure. Consequently, formal off-site planning is not required because the postulated worst-case accident involving an ISFSI has insignificant consequences to the public health and safety.

10 CFR 72.32 provides two means for satisfying its requirements. 10 CFR 72.32 (a) requires that the application for an ISFSI be accompanied by an Emergency Plan. 10 CFR 72.32 (c) allows that the emergency plan required by 10 CFR 50.47 for a nuclear power reactor licensed for operation by the Commission shall be deemed to satisfy the requirements for an ISFSI located on the site or located within the exclusion area as defined in 10 CFR 100. 10 CFR 72.32 (a) requires that an ISFSI Emergency Plan include a classification system for classifying accidents as "alerts". In contrast to the 10 CFR 72.32 requirements, regulations governing 10 CFR 50.47 emergency plans specify four emergency classes: (1) notification of unusual events, (2) alert, (3) site area emergency, and (4) general emergency, and require a determination of the adequacy of on-site and off-site emergency plans. 10 CFR 72.212(b)(6) requires that a general licensee review its reactor emergency plan to determine if its effectiveness is decreased and make necessary changes.

The expectations for off-site response to an alert classified under a 10 CFR 72.32 emergency plan are generally consistent with those for a notification of unusual event in a 10 CFR 50.47 emergency plan, i.e., to provide assistance if requested. Even with regard to activation of a licensee's emergency response organization (ERO), the ERO for a 10 CFR 72.32 emergency plan is not that prescribed under a 10 CFR 50.47 emergency plan, e.g., no Emergency Technical Support. Consequently, the "alerts" contemplated by 10 CFR 72.32, have been classified as NOUEs herein. To do otherwise could lead to an inappropriate response posture on the part of off-site response organizations.

NUREG-1567, Standard Review Plan for Spent Fuel Dry Storage Facilities, descriptions of initiating events appear below:

- FIRE on-site that might affect radioactive material of systems important to safety
- Severe natural phenomena projected to occur that might affect radioactive material or systems important to safety (e.g., flood, tsunami, hurricane, tidal surge, hurricane force winds)
- Severe natural phenomena or other incidents have occurred that may have affected radioactive material or systems important to safety, but initial assessment is not complete (e.g., beyond design basis earthquake, flood, tsunami, hurricane, tidal surge, hurricane force winds, tornado PROJECTILES, EXPLOSION, release of flammable gas)
- Elevated radiation levels or airborne contamination levels within the facility indicate severe loss of control (factor of 100 over normal levels)
- Ongoing security compromise (greater than 15 minutes)
- Accidental release of radioactivity within building confinement barrier (pool or waste management facility)

- Discovery of condition that creates a criticality hazard
- Other conditions that warrant precautionary activation of the licensee's emergency response organization

Note that 10 CFR 72.32 also discusses emergency planning license application requirements for Monitored Retrievable Storage Facilities (MRS) and for ISFSIs that may process and/or repackage spent fuel. 10 CFR 72.32 (b) requires that an Emergency Plan for an MRS or one of these more complex ISFSIs include a classification system for classifying accidents as "alerts" or "site area emergencies." NUREG-1567 provides a list of events that may initiate a site area emergency at one of these facilities. However, these facilities are beyond the scope of this discussion.

NUREG-1536, Standard Review Plan for Dry Cask Storage Systems, provides guidance for performing safety reviews of applications for approval of spent fuel DCSS. The principal purposes of the DCSS Standard Review Plan (SRP) are to ensure the quality and consistency of staff reviews and to establish a well-defined basis from which to evaluate proposed changes in the scope of reviews.

Accidents and events associated with natural phenomena may share common regulatory and design limits. By contrast, anticipated occurrences (off-normal conditions) are distinguished, in part, from accidents or natural phenomena by the appropriate regulatory guidance and design criteria. For example, the radiation dose from an off-normal event must not exceed the limits specified in 10 CFR Part 20 and 10 CFR 72.104(a), whereas the radiation dose from an accident or natural phenomenon must not exceed the specifications of 10 CFR 72.106(b). Accident conditions may also have different allowable structural criteria.

According to NUREG 1536, the following accidents should be evaluated in the SAR. Because of the NRC's defense-in-depth approach, each should be evaluated regardless of whether it is highly unlikely or highly improbable. These do not constitute the only accidents that should be addressed if the SAR is to serve as a reference for accidents for the site-specific application. Others that may be derived from a hazard analysis could include accidents resulting from operational error, instrument failure, lightning, and other occurrences. Accident situations that are not credible because of design features or other reasons should be identified and justified in the SAR.

- Section 2.0-V.2.b(3) - Accident Conditions
 - (a) Cask Drop
 - (b) Cask Tip Over
 - (c) Fire
 - (d) Fuel Rod Rupture
 - (e) Leakage of the CONFINEMENT BOUNDARY
 - (f) Explosive Overpressure
 - (g) Air Flow Blockage
- Section 2.0-V.2.b(4) - Natural Phenomena Events

- (a) Flood
- (b) Tornado
- (c) Earthquake
- (d) Burial under Debris
- (e) Lightning
- (f) Other natural phenomena events (including seiche, tsunامي, and hurricane)

The emergency classifications used are those provided by NUREG-0654/FEMA-REP-1. NOUE classifications provide an increased awareness for abnormal conditions. The source term and motive force available at a simple ISFSI is insufficient to warrant classifications above the NOUE level using the 10 CFR 50 emergency classification scheme.

Section 3.3 of NUMARC/NESP-007 emphasizes the need for accurate assessment and classification of events. It is intended that primary emphasis be placed on observable conditions in classifying emergency events. For an ISFSI, these conditions are primarily associated with the CONFINEMENT BOUNDARY of a loaded fuel storage cask.

E.2 Initiating Conditions

NOUE (E-HU1) Damage to a loaded cask CONFINEMENT BOUNDARY.

The Emergency Director has the discretion to classify events based on the classification level definitions. This discretion should be used when conditions or events are observed and no specific IC/EAL is apparent. The NOUE will heighten awareness of the abnormal condition. Natural phenomena events and accident conditions are classified at the NOUE level in the event that a loaded cask CONFINEMENT BOUNDARY is damaged or violated.