

**UNITED STATES NUCLEAR REGULATORY COMMISSION
PRESSURIZED WATER REACTOR GENERIC FUNDAMENTALS EXAMINATION
DECEMBER 2007--FORM A**

Please Print

Name: _____

Docket No.: _____

Facility: _____

Start Time: _____ Stop Time: _____

INSTRUCTIONS TO APPLICANT

Answer all the test items using the answer sheet provided, ensuring a single answer is marked for each test item. Each test item has equal point value. A score of at least 80% is required to pass this portion of the NRC operator licensing written examination. All examination papers will be collected 3.0 hours after the examination starts. This examination applies to a typical pressurized water reactor (PWR) nuclear power plant.

SECTION	QUESTIONS	% OF TOTAL	SCORE
COMPONENTS	1 - 22		
REACTOR THEORY	23 - 36		
THERMODYNAMICS	37 - 50		
TOTALS	50		

All work performed on this examination is my own. I have neither given nor received aid.

Applicant's Signature

**RULES AND GUIDELINES FOR THE NRC
GENERIC FUNDAMENTALS EXAMINATION**

During the administration of this examination the following rules apply:

NOTE: The generic term "control rod" refers to the length of neutron absorber material that can be positioned by the operator to change core reactivity.

1. Print your name in the blank provided on the cover sheet of the examination.
2. Fill in your individual docket number.
3. Fill in the name of your facility.
4. Fill in your start and stop times at the appropriate time.
5. Two aids are provided for your use during the examination:
 - (1) An equations and conversions sheet contained within the examination copy, and
 - (2) Steam tables and Mollier Diagram provided by your proctor.
6. Place your answers on the answer sheet provided. Credit will only be given for answers properly marked on this sheet. Follow the instructions for filling out the answer sheet.
7. Scrap paper will be provided for calculations.
8. Cheating on the examination will result in the automatic forfeiture of this examination. Cheating could also result in severe penalties.
9. Restroom trips are limited. Only **ONE** examinee may leave the room at a time. In order to avoid the appearance or possibility of cheating, avoid all contact with anyone outside of the examination room.
10. After you have completed the examination, sign the statement on the cover sheet indicating that the work is your own and you have neither given nor received any assistance in completing the examination. Either pencil or pen may be used.
11. Turn in your examination materials, answer sheet on top, followed by the examination copy and the examination aids - steam table booklets, handouts, and scrap paper used during the examination.
12. After turning in your examination materials, leave the examination area, as defined by the proctor. If after leaving you are found in the examination area while the examination is in progress, your examination may be forfeited.

GENERIC FUNDAMENTALS EXAMINATION
EQUATIONS AND CONVERSIONS HANDOUT SHEET

EQUATIONS

$$\dot{Q} = \dot{m}c_p\Delta T$$

$$\dot{Q} = \dot{m}\Delta h$$

$$\dot{Q} = UA\Delta T$$

$$\dot{Q} \propto \dot{m}_{\text{Nat Circ}}^3$$

$$\Delta T \propto \dot{m}_{\text{Nat Circ}}^2$$

$$K_{\text{eff}} = 1/(1 - \rho)$$

$$\rho = (K_{\text{eff}} - 1)/K_{\text{eff}}$$

$$\text{SUR} = 26.06/\tau$$

$$\tau = \frac{\bar{\beta}_{\text{eff}} - \rho}{\lambda_{\text{eff}} \rho}$$

$$\rho = \frac{\ell^*}{\tau} + \frac{\bar{\beta}_{\text{eff}}}{1 + \lambda_{\text{eff}} \tau}$$

$$\ell^* = 1 \times 10^{-4} \text{ sec}$$

$$\lambda_{\text{eff}} = 0.1 \text{ sec}^{-1} \text{ (for small positive } \rho)$$

$$\text{DRW} \propto \phi_{\text{tip}}^2 / \phi_{\text{avg}}^2$$

$$P = P_o 10^{\text{SUR}(t)}$$

$$P = P_o e^{(t/\tau)}$$

$$A = A_o e^{-\lambda t}$$

$$\text{CR}_{\text{S/D}} = S/(1 - K_{\text{eff}})$$

$$\text{CR}_1(1 - K_{\text{eff}1}) = \text{CR}_2(1 - K_{\text{eff}2})$$

$$1/M = \text{CR}_1/\text{CR}_x$$

$$A = \pi r^2$$

$$F = PA$$

$$\dot{m} = \rho A \bar{v}$$

$$\dot{W}_{\text{Pump}} = \dot{m} \Delta P v$$

$$E = IR$$

$$\text{Thermal Efficiency} = \text{Net Work Out/Energy In}$$

$$\frac{g(z_2 - z_1)}{g_c} + \frac{(\bar{v}_2^2 - \bar{v}_1^2)}{2g_c} + v(P_2 - P_1) + (u_2 - u_1) + (q - w) = 0$$

$$g_c = 32.2 \text{ lbm-ft/lbf-sec}^2$$

CONVERSIONS

$$1 \text{ Mw} = 3.41 \times 10^6 \text{ Btu/hr}$$

$$1 \text{ hp} = 2.54 \times 10^3 \text{ Btu/hr}$$

$$1 \text{ Btu} = 778 \text{ ft-lbf}$$

$$^\circ\text{C} = (5/9)(^\circ\text{F} - 32)$$

$$^\circ\text{F} = (9/5)(^\circ\text{C}) + 32$$

$$1 \text{ Curie} = 3.7 \times 10^{10} \text{ dps}$$

$$1 \text{ kg} = 2.21 \text{ lbm}$$

$$1 \text{ gal}_{\text{water}} = 8.35 \text{ lbm}$$

$$1 \text{ ft}^3_{\text{water}} = 7.48 \text{ gal}$$

**USNRC GENERIC FUNDAMENTALS EXAMINATION
DECEMBER 2007 PWR--FORM A**

QUESTION: 1

Refer to the drawing of a cooling water system in which both centrifugal pumps A and B are operating (see figure below).

An operator stops pump B, but the pump B check valve fails to close. In comparison to normal operation with only pump A running, operation with the failed pump B check valve will result in pump A flow rate being _____ than normal; and heat exchanger flow rate being _____ than normal.

- A. higher; lower
- B. higher; higher
- C. lower; lower
- D. lower; higher

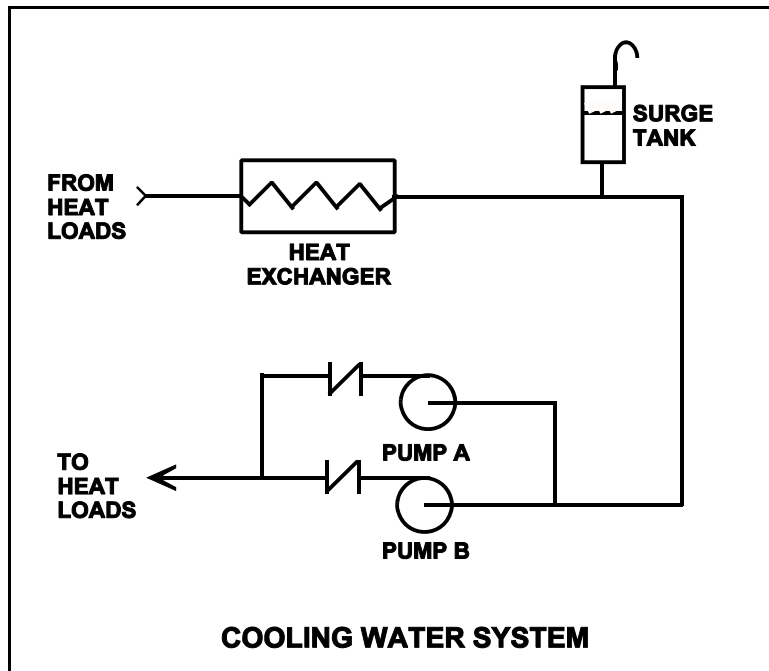

**USNRC GENERIC FUNDAMENTALS EXAMINATION
DECEMBER 2007 PWR--FORM A**

QUESTION: 2

A surveillance test procedure is being performed on a typical Limatorque[®] motor-operated valve (MOV) used in an emergency core cooling system (ECCS) application. The declutch lever has been operated and released and the valve is being manually/locally opened by a technician. The MOV breaker is closed as required by the surveillance test procedure. During operation of the valve handwheel an ECCS actuation signal is received that normally energizes the valve motor and closes the valve.

How will the valve be affected by the actuation signal?

- A. The handwheel will disengage and the valve will automatically close.
- B. The handwheel will disengage and the valve will remain in the current position.
- C. The handwheel will remain engaged and the valve will automatically close.
- D. The handwheel will remain engaged and the technician can continue to open the valve.

**USNRC GENERIC FUNDAMENTALS EXAMINATION
DECEMBER 2007 PWR--FORM A**

QUESTION: 3

Refer to the drawing of a pressurizer differential pressure (D/P) level detection system (see figure below).

A nuclear reactor is shutdown with the reactor coolant system being maintained at 100 psia. The level detector has just been calibrated. Suddenly a rupture in the condensing pot of the level detector results in a rapid drop of the condensing pot pressure to atmospheric pressure.

Given the following current conditions:

- The condensing pot is at atmospheric pressure.
- Pressurizer pressure is 98 psia and slowly decreasing.
- Bulk reference leg temperature is 120°F.
- Actual pressurizer level has not changed significantly.

Which one of the following describes the current pressurizer level indication from the detector?

- A. Offscale low because the bulk of the water in the reference leg has flashed to steam.
- B. Offscale high because the bulk of the water in the reference leg has flashed to steam.
- C. Offscale low because the static pressure on the reference leg is much less than the static pressure in the pressurizer.
- D. Offscale high because the static pressure on the reference leg is much less than the static pressure in the pressurizer.

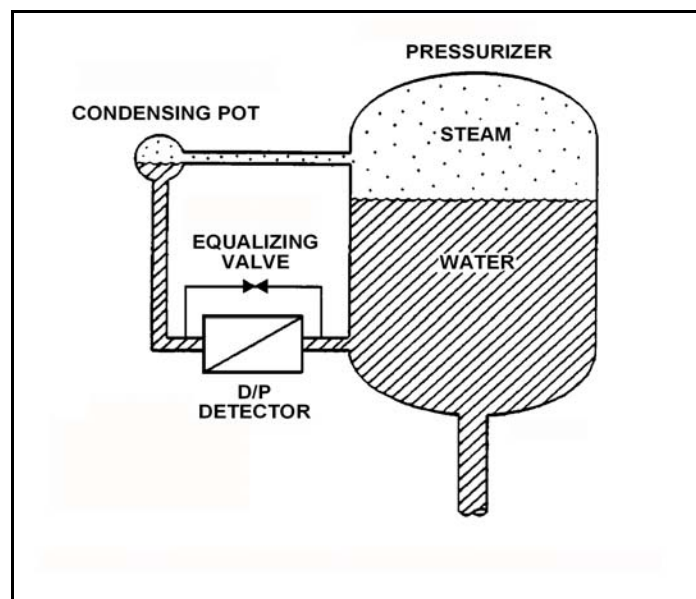

**USNRC GENERIC FUNDAMENTALS EXAMINATION
DECEMBER 2007 PWR--FORM A**

QUESTION: 4

A centrifugal pump is taking suction from the bottom of a vented cylindrical storage tank that contains 100,000 gallons of water at 60°F. A pressure gauge at the inlet to the pump indicates 40 psig. Over the next several days storage tank temperature increases to 90°F with no change in tank water level and no change in head loss in the pump suction line.

Which one of the following is the current pressure at the inlet to the pump?

- A. 39.8 psig
- B. 37.4 psig
- C. 34.6 psig
- D. 31.2 psig

**USNRC GENERIC FUNDAMENTALS EXAMINATION
DECEMBER 2007 PWR--FORM A**

QUESTION: 5

Refer to the simplified drawing of a control rod position detector (see figure below).

Coils of wire connected to an ac power supply are being used to monitor the position of a control rod in a nuclear reactor. The coils are mounted in a column outside the reactor vessel head such that the steel control rod drive shaft passes upward through the coils as the control rod is withdrawn. Currently, the top of a control rod drive shaft is located between coils A and B as shown. The control rod is to be withdrawn until the top of the control rod drive shaft is located just below coil C.

Compared to the initial coil output currents, after the control rod is withdrawn the output current of coil A will be _____; and the output current of coil B will be _____.

- A. higher; higher
- B. higher; lower
- C. the same; higher
- D. the same; lower

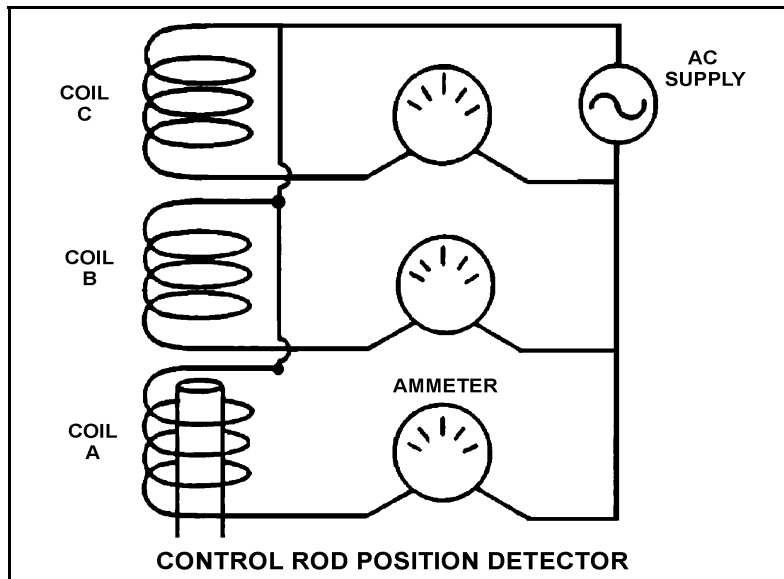

**USNRC GENERIC FUNDAMENTALS EXAMINATION
DECEMBER 2007 PWR--FORM A**

QUESTION: 6

Which one of the following describes a characteristic of a self-reading pocket dosimeter (SRPD)?

- A. The output of an SRPD is a dose rate in mR/hr.
- B. SRPDs are primarily sensitive to beta radiation.
- C. SRPD readings must be considered inaccurate when they are dropped.
- D. SRPDs hold their charge indefinitely when removed from a radiation field.

QUESTION: 7

An emergency diesel generator (D/G) is operating as the only power source connected to an emergency bus. The governor of the D/G is directly sensing D/G _____ and will directly adjust D/G _____ flow to maintain a relatively constant D/G frequency.

- A. speed; fuel
- B. speed; air
- C. load; fuel
- D. load; air

**USNRC GENERIC FUNDAMENTALS EXAMINATION
DECEMBER 2007 PWR--FORM A**

QUESTION: 8

Refer to the drawing of four bistable symbols (see figure below).

A temperature controller uses a bistable that turns on to actuate a warning light when the controlled temperature reaches a low setpoint. The warning light extinguishes immediately after the temperature increases above the low setpoint.

Which one of the following bistable symbols indicates the characteristics of the bistable?

- A. 1.
- B. 2.
- C. 3.
- D. 4.

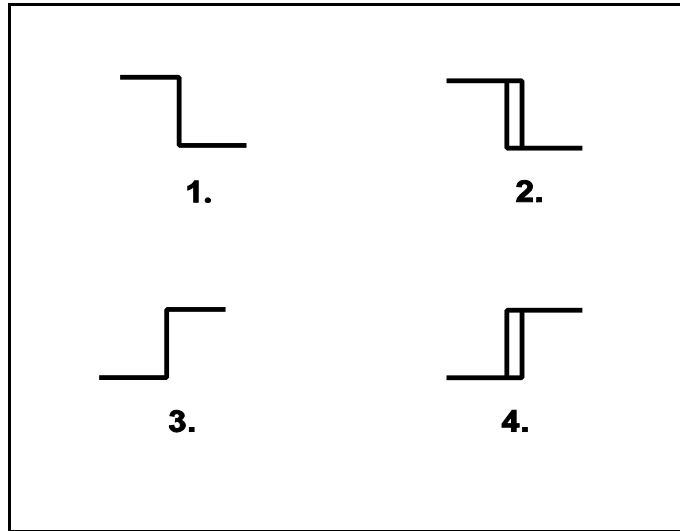

**USNRC GENERIC FUNDAMENTALS EXAMINATION
DECEMBER 2007 PWR--FORM A**

QUESTION: 9

Refer to the valve controller logic diagram (see figure below).

Which one of the following combinations of inputs will result in the valve receiving an open signal?

	INPUTS			
	1.	2.	3.	4.
A.	On	Off	On	On
B.	Off	On	Off	Off
C.	On	Off	Off	On
D.	Off	On	On	Off

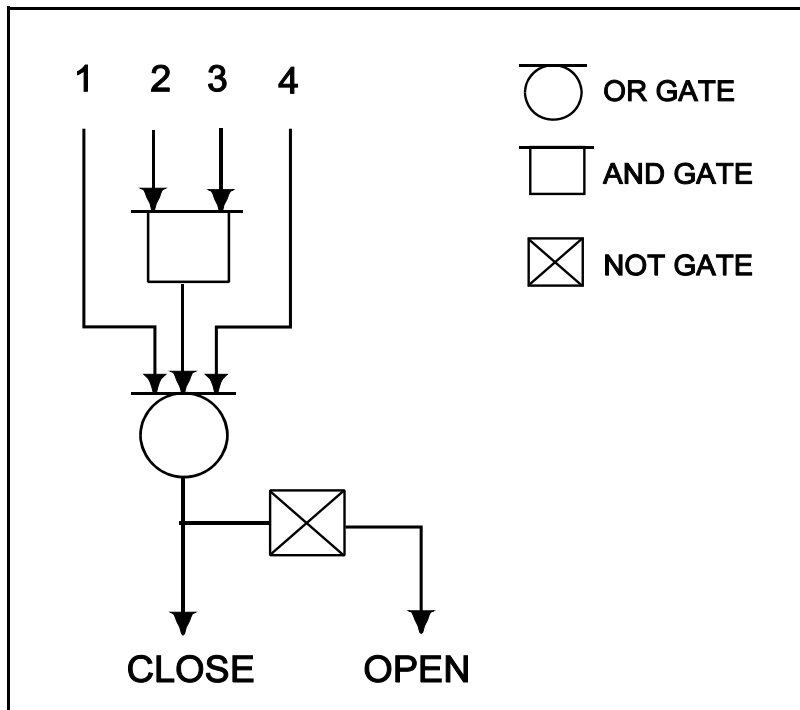

**USNRC GENERIC FUNDAMENTALS EXAMINATION
DECEMBER 2007 PWR--FORM A**

QUESTION: 10

Which one of the following is an effective method for ensuring that a centrifugal pump remains primed and does not become gas bound during operation and after shutdown?

- A. Install an orifice plate in the discharge piping of the pump.
- B. Install a pump recirculation line from the pump discharge piping to the pump supply piping.
- C. Install the pump below the level of the suction supply.
- D. Install a check valve in the discharge piping of the pump.

**USNRC GENERIC FUNDAMENTALS EXAMINATION
DECEMBER 2007 PWR--FORM A**

QUESTION: 11

Refer to the drawing of an elevated centrifugal pump taking suction from the bottom of an open storage tank containing water at 66°F (see figure below). Assume standard atmospheric pressure.

The pump requires 4.0 ft-lbf/lbm of net positive suction head (NPSH). Assume that pump suction fluid velocity head loss is negligible.

If tank water level is allowed to decrease continuously, at what approximate water level will the pump begin to cavitate?

- A. 34 feet
- B. 29 feet
- C. 21 feet
- D. 16 feet

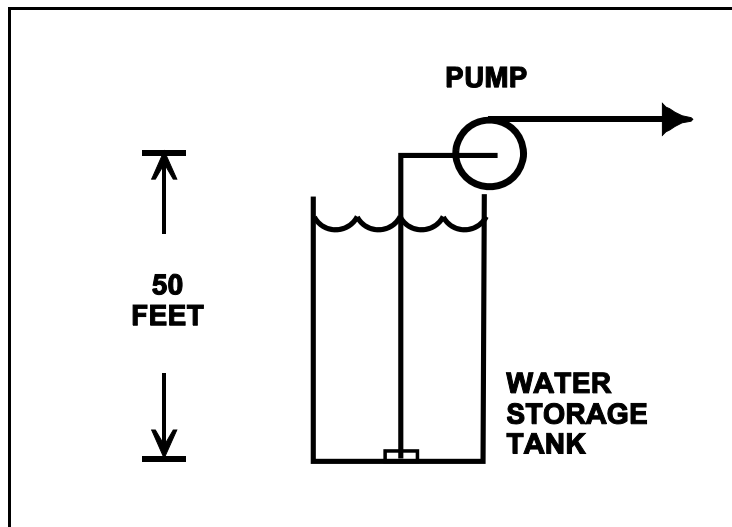

**USNRC GENERIC FUNDAMENTALS EXAMINATION
DECEMBER 2007 PWR--FORM A**

QUESTION: 12

A motor-driven centrifugal pump is operating in a closed-loop cooling water system and is unable to achieve its rated volumetric flow rate due to cavitation. Which one of the following will enable the pump to achieve a higher volumetric flow rate before cavitation occurs?

- A. Operate the system at a higher pressure.
- B. Operate the system at a higher temperature.
- C. Remove the existing pump motor and install a motor with a higher horsepower rating.
- D. Remove the existing pump and install a same-capacity pump with a higher minimum required net positive suction head rating.

QUESTION: 13

Which one of the following conditions will result in the greatest increase in volumetric flow rate in a water system with one positive displacement pump operating at 400 rpm and a discharge pressure of 100 psig?

- A. Increasing pump speed to 700 rpm.
- B. Decreasing pump discharge pressure to 40 psig.
- C. Starting a second identical positive displacement pump in series with the first pump.
- D. Starting a second identical positive displacement pump in parallel with the first pump.

**USNRC GENERIC FUNDAMENTALS EXAMINATION
DECEMBER 2007 PWR--FORM A**

QUESTION: 14

A main generator is connected to an infinite power grid. Which one of the following pairs of main generator output parameters places the generator in the closest proximity to slipping a pole.

- A. 800 MW; 200 MVAR (in)
- B. 800 MW; 600 MVAR (in)
- C. 400 MW; 200 MVAR (out)
- D. 400 MW; 600 MVAR (out)

QUESTION: 15

Which one of the following is the primary reason for limiting the number of motor starts in a given time period?

- A. Minimizes pitting of contacts in the motor breaker.
- B. Prevents excessive torsional stresses on motor shaft.
- C. Prevents overheating of motor windings.
- D. Minimizes axial stresses on motor bearings.

**USNRC GENERIC FUNDAMENTALS EXAMINATION
DECEMBER 2007 PWR--FORM A**

QUESTION: 16

Steam has been admitted to a main condenser for 25 minutes with no cooling water. Initiating full cooling water flow rate at this time will...

- A. reduce the stress on the condenser shell by rapidly cooling the shell.
- B. reduce the stress on the condenser tubes by rapidly cooling the tubes.
- C. induce large thermal stresses on the condenser shell.
- D. induce large thermal stresses on the junctions between the condenser tubes and the tubesheet.

**USNRC GENERIC FUNDAMENTALS EXAMINATION
DECEMBER 2007 PWR--FORM A**

QUESTION: 17

Refer to the drawing of an operating lube oil heat exchanger (see figure below).

The heat exchanger was operating with the following initial parameters:

Cooling water inlet temperature (T_{cw-in}) = 71 °F
Cooling water outlet temperature (T_{cw-out}) = 91 °F
Oil inlet temperature (T_{oil-in}) = 175 °F
Oil outlet temperature ($T_{oil-out}$) = 125 °F

The heat exchanger was vented, resulting in the following current parameters:

Cooling water inlet temperature (T_{cw-in}) = 71 °F
Cooling water outlet temperature (T_{cw-out}) = 95 °F
Oil inlet temperature (T_{oil-in}) = 175 °F
Oil outlet temperature ($T_{oil-out}$) = ?

Assume that the mass flow rates and specific heats of both fluids were unchanged.

Which one of the following is the current lube oil outlet temperature ($T_{oil-out}$)?

- A. 115 °F
- B. 120 °F
- C. 130 °F
- D. 135 °F

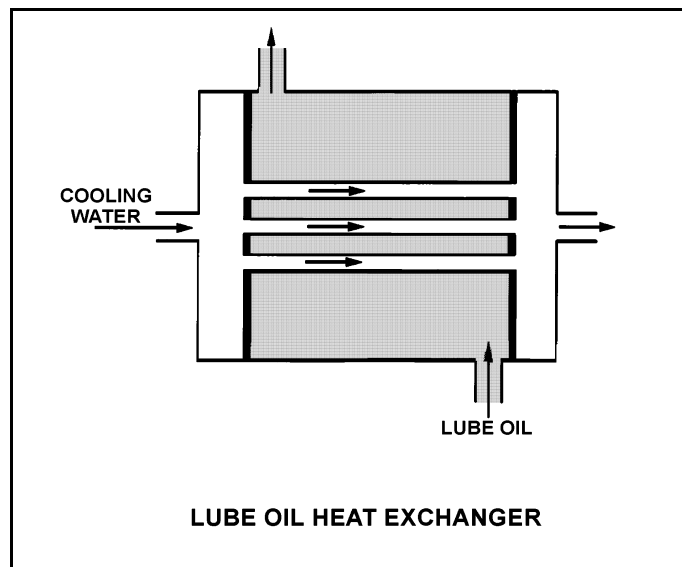

**USNRC GENERIC FUNDAMENTALS EXAMINATION
DECEMBER 2007 PWR--FORM A**

QUESTION: 18

Two indications of channeling through an operating demineralizer are a _____-than-normal demineralizer differential pressure and a _____-than-normal demineralization factor

- A. higher; lower
- B. higher; higher
- C. lower; lower
- D. lower; higher

QUESTION: 19

A PWR nuclear power plant has two identical mixed resin reactor coolant ion exchangers, A and B, which operated in parallel service continuously for two weeks of power operation immediately after a refueling outage. Then, ion exchanger A was removed from service while ion exchanger B remained in service. After 10 months of continuous operation at full power, it is necessary to place ion exchanger A in service and remove ion exchanger B from service.

Which one of the following describes why the effluent from ion exchanger A initially will be drained to a collection facility prior to fully placing the ion exchanger in service?

- A. To avoid an undesired increase in reactor coolant pH.
- B. To avoid an undesired decrease in reactor coolant pH.
- C. To avoid an undesired increase in reactor coolant boron concentration.
- D. To avoid an undesired decrease in reactor coolant boron concentration.

**USNRC GENERIC FUNDAMENTALS EXAMINATION
DECEMBER 2007 PWR--FORM A**

QUESTION: 20

Which one of the following results from a loss of control power to a breaker supplying a motor?

- A. Motor ammeter indication will be zero regardless of actual breaker position.
- B. Breaker position will remotely indicate closed regardless of actual position.
- C. Breaker will trip open due to the actuation of its protective trip device.
- D. Charging motor will not recharge the closing spring after the breaker closes.

**USNRC GENERIC FUNDAMENTALS EXAMINATION
DECEMBER 2007 PWR--FORM A**

QUESTION: 21

Refer to the drawing of a valve control circuit (see figure below).

Note: Limit switch (LS) contacts are shown open regardless of valve position, but relay contacts are shown open/closed according to the standard convention for control circuit drawings.

Which one of the following conditions will actuate the alarm?

- A. The valve is partially closed with the control switch in the CLOSE position.
- B. The valve is fully open with the control switch in the CLOSE position.
- C. The valve is partially closed with the control switch in the OPEN position.
- D. The valve is fully open with the control switch in the OPEN position.

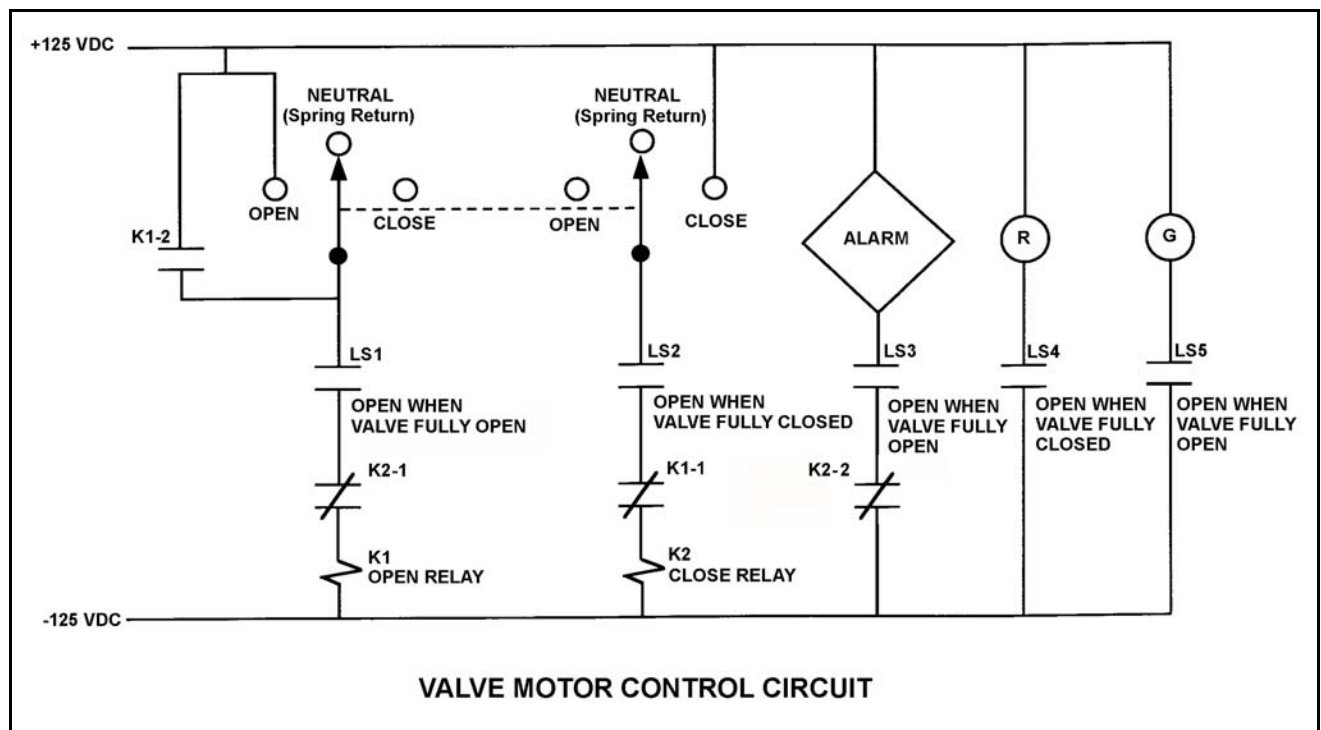

**USNRC GENERIC FUNDAMENTALS EXAMINATION
DECEMBER 2007 PWR--FORM A**

QUESTION: 22

While remotely investigating the condition of a typical normally-open motor control center (MCC) feeder breaker, an operator observes the following indications:

Green breaker position indicating light is lit.
Red breaker position indicating light is out.
MCC voltmeter indicates zero volts.
MCC ammeter indicates zero amperes.

Based on these indications, the operator can accurately report that the breaker is open and racked to _____ position.

- A. the OUT
- B. the IN
- C. the TEST
- D. an unknown

QUESTION: 23

In a comparison between a delayed neutron and a prompt neutron born from the same fission event, the delayed neutron is more likely to... (Assume that each neutron remains in the reactor core.)

- A. cause fission of a U-238 nucleus.
- B. cause fission of a U-235 nucleus.
- C. travel to an adjacent fuel assembly.
- D. experience resonance absorption in the core.

**USNRC GENERIC FUNDAMENTALS EXAMINATION
DECEMBER 2007 PWR--FORM A**

QUESTION: 24

Which one of the following conditions describes a nuclear reactor that is exactly critical?

- A. $K_{\text{eff}} = 0$; $\Delta K/K = 0$
- B. $K_{\text{eff}} = 0$; $\Delta K/K = 1$
- C. $K_{\text{eff}} = 1$; $\Delta K/K = 0$
- D. $K_{\text{eff}} = 1$; $\Delta K/K = 1$

QUESTION: 25

The following data is given for the fuel in an operating nuclear reactor core:

<u>Nuclide</u>	<u>Delayed Neutron Fraction</u>	<u>Fraction of Total Fuel Composition</u>	<u>Fraction of Total Fission Rate</u>
U-235	0.0065	0.023	0.63
U-238	0.0148	0.965	0.07
Pu-239	0.0021	0.012	0.30

What is the core delayed neutron fraction for this reactor?

- A. 0.0052
- B. 0.0058
- C. 0.0072
- D. 0.0078

**USNRC GENERIC FUNDAMENTALS EXAMINATION
DECEMBER 2007 PWR--FORM A**

QUESTION: 26

Which one of the following is an effect of fuel pellet expansion during the normal operation of a nuclear power plant?

- A. Decreased fuel rod clad strain.
- B. Decreased decay heat generation rate.
- C. Decreased neutron resonance absorption rate.
- D. Decreased core effective delayed neutron fraction.

QUESTION: 27

Differential boron reactivity worth will become _____ negative as moderator temperature increases because, at higher moderator temperatures, a 1 ppm increase in reactor coolant system boron concentration will add _____ boron atoms to the core.

- A. less; more
- B. less; fewer
- C. more; more
- D. more; fewer

**USNRC GENERIC FUNDAMENTALS EXAMINATION
DECEMBER 2007 PWR--FORM A**

QUESTION: 28

A nuclear reactor is critical at the point of adding heat (POAH) during a reactor startup near the end of a fuel cycle. Control rods are manually withdrawn for 5 seconds and then stopped.

Assuming only ambient heat removal from the reactor coolant system (RCS), when plant parameters stabilize reactor power will be _____ the POAH, and RCS average temperature will be _____.

- A. at; higher
- B. at; the same
- C. greater than; higher
- D. greater than; the same

QUESTION: 29

A nuclear reactor is operating at 85% power with the controlling group of control rods inserted 10%. Which one of the following will cause the differential rod worth of the controlling group to become more negative? (Assume reactor power and control rod position remain constant for each case.)

- A. RCS boron concentration is increased by 5 ppm.
- B. Core Xe-135 builds up in the lower half of the core.
- C. RCS average temperature drifts from 580°F to 575°F.
- D. Fuel temperature increases as fission product gasses accumulate in a fuel rod.

**USNRC GENERIC FUNDAMENTALS EXAMINATION
DECEMBER 2007 PWR--FORM A**

QUESTION: 30

A fission product poison can be differentiated from all other fission products in that a fission product poison...

- A. will be produced in direct proportion to the fission rate in the core.
- B. will remain radioactive for thousands of years after the final reactor criticality.
- C. will depress the power production in some core locations and cause peaking in others.
- D. will migrate out of the fuel pellets and into the reactor coolant via pinhole defects in the clad.

QUESTION: 31

A nuclear reactor has been shut down for seven days to perform maintenance. A reactor startup is performed and power level is increased to 50% over a 5-hour period.

When power reaches 50%, the magnitude of core xenon negative reactivity will be...

- A. increasing toward a peak.
- B. increasing toward equilibrium.
- C. decreasing toward equilibrium.
- D. decreasing toward a valley.

**USNRC GENERIC FUNDAMENTALS EXAMINATION
DECEMBER 2007 PWR--FORM A**

QUESTION: 32

A nuclear reactor is operating near the end of its fuel cycle. Reactor power and reactor coolant system (RCS) temperature are being allowed to "coast down."

Why is RCS boron dilution no longer used for reactivity control?

- A. The reactivity worth of the boron has increased so much that reactivity changes from RCS boron dilution cannot be safely controlled by the operator.
- B. The reactivity worth of the boron has decreased so much that a very large amount of water must be added to the RCS to make a small positive reactivity addition to the core.
- C. RCS boron concentration has become so high that a very large amount of boron must be added to produce a small increase in boron concentration.
- D. RCS boron concentration has become so low that a very large amount of water must be added to the RCS to produce a small decrease in boron concentration.

**USNRC GENERIC FUNDAMENTALS EXAMINATION
DECEMBER 2007 PWR--FORM A**

QUESTION: 33

Refer to the drawing of a $1/M$ plot with curves A and B (see figure below). Assume that each axis has linear units.

Curve A would result if each fuel assembly loaded during the early stages of the refueling caused a relatively _____ fractional change in source range count rate compared to the later stages of the refueling; curve B would result if each fuel assembly contained equal _____.

- A. small; fuel enrichment
- B. small; reactivity
- C. large; fuel enrichment
- D. large; reactivity

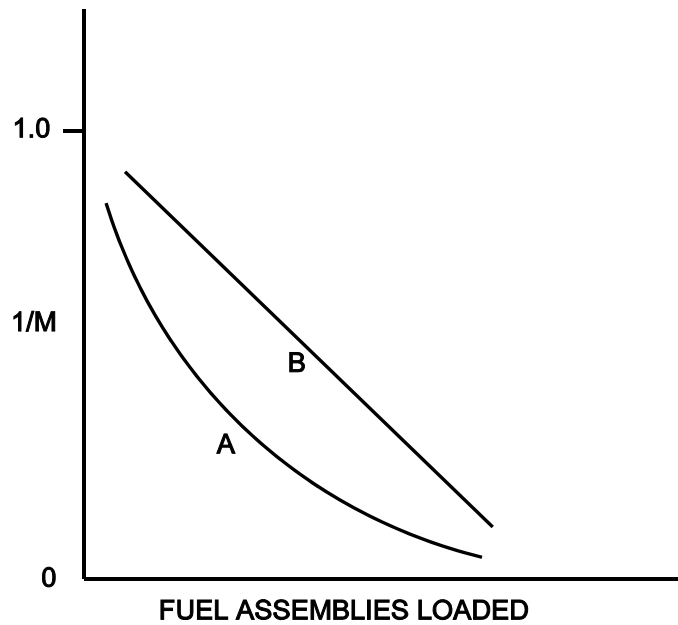

**USNRC GENERIC FUNDAMENTALS EXAMINATION
DECEMBER 2007 PWR--FORM A**

QUESTION: 34

A nuclear reactor is critical below the point of adding heat (POAH). The operator adds enough reactivity to attain a startup rate of 0.5 decades per minute. Which one of the following will decrease first when the reactor reaches the POAH?

- A. Pressurizer level
- B. Reactor coolant temperature
- C. Reactor power
- D. Startup rate

QUESTION: 35

A refueling outage has just been completed in which one-third of the core was replaced with new fuel assemblies. A reactor startup has been performed to mark the beginning of the sixth fuel cycle and reactor power is being increased to 100%.

Which one of the following pairs of reactor fuels will be providing the greatest contribution to core heat production when the reactor reaches 100% power?

- A. U-235 and U-238
- B. U-235 and Pu-239
- C. U-235 and Pu-241
- D. U-238 and Pu-239

**USNRC GENERIC FUNDAMENTALS EXAMINATION
DECEMBER 2007 PWR--FORM A**

QUESTION: 36

A nuclear reactor was shut down one week ago following several months of operation at 100% power. Reactor coolant is being maintained at 500°F and all reactor coolant pumps are operating.

The principle source of heat input to the reactor coolant is from...

- A. reactor coolant pumps.
- B. subcritical thermal fission of U-235 and Pu-239.
- C. subcritical fast fission of U-238.
- D. fission product decay.

**USNRC GENERIC FUNDAMENTALS EXAMINATION
DECEMBER 2007 PWR--FORM A**

QUESTION: 37

Refer to the drawing of four differential pressure (D/P) level detectors (see figure below).

The tanks are identical and are being maintained at 17 psia and 70% water level (calibration conditions). They are located in a building that is currently at atmospheric pressure.

If the building ventilation system creates a vacuum in the building, which level detectors will provide the lowest level indications?

- A. 1 and 3
- B. 1 and 4
- C. 2 and 3
- D. 2 and 4

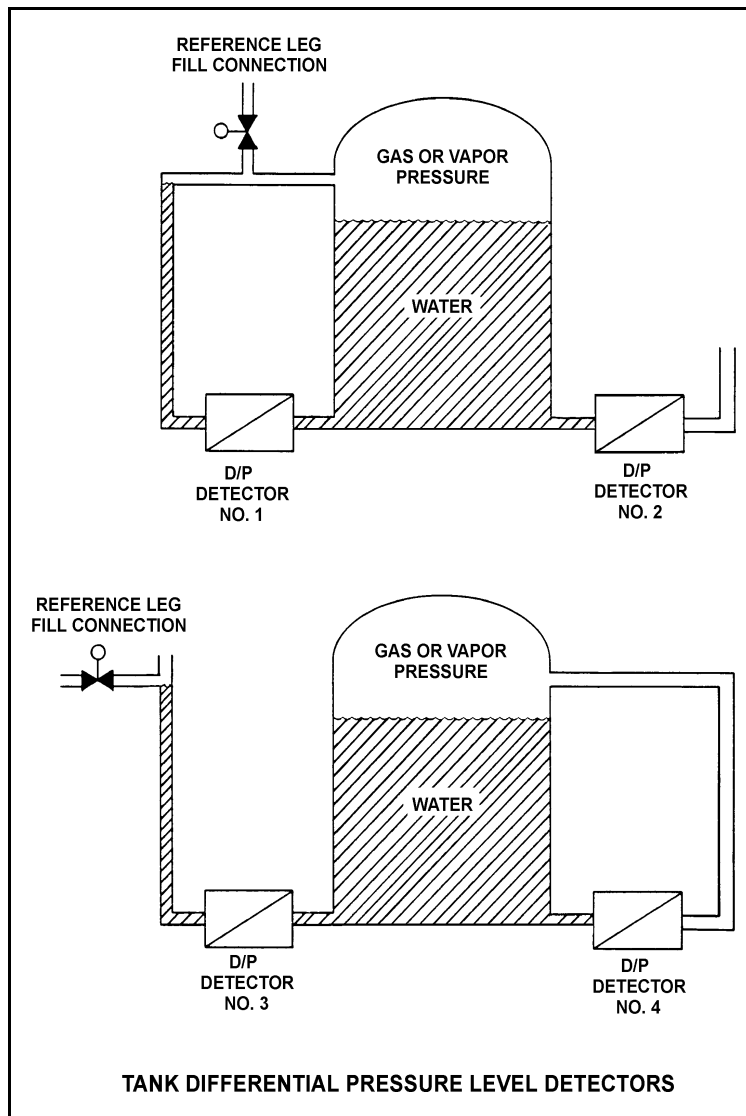

**USNRC GENERIC FUNDAMENTALS EXAMINATION
DECEMBER 2007 PWR--FORM A**

QUESTION: 38

Consider a pressurizer containing a saturated water/steam mixture at 636°F with a quality of 50%. If an outsurge removes 10% of the liquid volume from the pressurizer, the temperature of the mixture will _____ and the quality of the mixture will _____. (Assume the mixture remains saturated.)

- A. decrease; decrease
- B. decrease; increase
- C. remain the same; decrease
- D. remain the same; increase

QUESTION: 39

An ideal auxiliary steam turbine exhausts to the atmosphere. The steam turbine is supplied with saturated steam at 900 psia. Which one of the following is the maximum specific work (Btu/lbm) that can be extracted from the steam by the steam turbine?

- A. 283 Btu/lbm
- B. 670 Btu/lbm
- C. 913 Btu/lbm
- D. 1,196 Btu/lbm

**USNRC GENERIC FUNDAMENTALS EXAMINATION
DECEMBER 2007 PWR--FORM A**

QUESTION: 40

A pressurizer safety valve is leaking by, allowing the 100% quality steam in the pressurizer to flow to the pressurizer relief tank (PRT). The reactor has been shut down, and a plant cooldown and depressurization are in progress. PRT pressure is being maintained constant at 20 psig.

Which one of the following describes how safety valve tailpipe temperature will be affected as pressurizer pressure slowly decreases from 1,500 psia to 500 psia? (Assume there is no ambient heat loss from the tailpipe.)

- A. Increases, because the entropy of the pressurizer steam will be increasing.
- B. Increases, because the enthalpy of the pressurizer steam will be increasing.
- C. Decreases, because the mass flow rate of the leaking steam will be decreasing.
- D. Decreases, because the temperature of the pressurizer steam will be decreasing.

QUESTION: 41

Consider the thermal efficiency of a nuclear power plant operating at rated power.

If the pressure at which saturated steam is produced in the steam generators is increased, thermal efficiency will _____; and if the temperature of the feedwater entering the steam generators is increased, thermal efficiency will _____.

- A. increase; increase
- B. increase; decrease
- C. decrease; increase
- D. decrease; decrease

**USNRC GENERIC FUNDAMENTALS EXAMINATION
DECEMBER 2007 PWR--FORM A**

QUESTION: 42

Reactor coolant system (RCS) hot leg temperature is 520°F and RCS pressure is decreasing due to a small leak. Which one of the following pressure ranges includes the pressure at which two-phase flow will first occur in the hot leg?

- A. 950 to 901 psig
- B. 900 to 851 psig
- C. 850 to 801 psig
- D. 800 to 751 psig

QUESTION: 43

A four-loop PWR nuclear power plant uses four identical single-speed reactor coolant pumps (RCPs) to supply reactor coolant flow through the reactor vessel. The plant is currently shut down with one RCP in operation.

Which one of the following describes the stable reactor coolant flow rate through the reactor vessel following the start of a second RCP?

- A. Less than twice the original flow rate.
- B. Exactly twice the original flow rate.
- C. More than twice the original flow rate.
- D. Cannot be determined without additional information.

**USNRC GENERIC FUNDAMENTALS EXAMINATION
DECEMBER 2007 PWR--FORM A**

QUESTION: 44

A nuclear reactor is operating at 80% power with a core ΔT of 48°F when a station blackout occurs. Natural circulation is established and core ΔT stabilizes at 40°F. If mass flow rate is 3%, which one of the following is the current decay heat level?

- A. 1%
- B. 2%
- C. 3%
- D. 4%

QUESTION: 45

Increasing coolant flow rate through a nuclear reactor core improves heat transfer from the fuel because it _____ the laminar film thickness and _____ the temperature of the coolant adjacent to the fuel.

- A. increases; raises
- B. increases; lowers
- C. decreases; raises
- D. decreases; lowers

**USNRC GENERIC FUNDAMENTALS EXAMINATION
DECEMBER 2007 PWR--FORM A**

QUESTION: 46

Refer to the drawing of a section of pipe that contains flowing water (see figure below).

Given:

Pressure at P_1 is 24 psig.

Pressure at P_2 is 16 psig.

Pressure change due to change in velocity is 2 psig.

Pressure change due to change in elevation is 10 psig.

The pressure decrease due to friction head loss between P_1 and P_2 is _____; and the direction of flow is from _____.

- A. 2 psig; left to right
- B. 2 psig; right to left
- C. 4 psig; left to right
- D. 4 psig; right to left

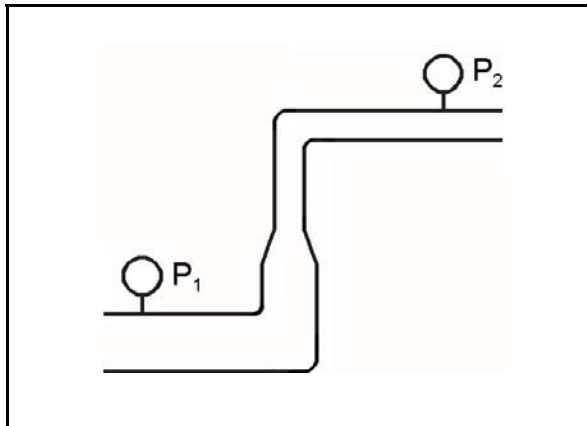

**USNRC GENERIC FUNDAMENTALS EXAMINATION
DECEMBER 2007 PWR--FORM A**

QUESTION: 47

Adequate core bypass flow is needed to...

- A. cool the excore nuclear instrument detectors.
- B. provide reactor coolant pump minimum flow requirements.
- C. prevent stratification of reactor coolant inside the reactor vessel.
- D. equalize the temperatures between the reactor vessel and the upper vessel head.

QUESTION: 48

A nuclear power plant is experiencing natural circulation core cooling following a loss of coolant accident. Which one of the following, when it first occurs, marks the beginning of reflux core cooling? (Assume the steam generators contain U-tubes.)

- A. Reactor core steam production results in two-phase coolant entering the hot leg and being delivered to the steam generators.
- B. Hot leg steam quality is so high that the steam generators cannot fully condense it and two-phase coolant is returned to the reactor vessel via the cold leg.
- C. Hot leg condensation is unable to pass completely through the steam generators to enter the cold legs.
- D. The steam generators are no longer able to condense any of the steam contained in the hot leg.

**USNRC GENERIC FUNDAMENTALS EXAMINATION
DECEMBER 2007 PWR--FORM A**

QUESTION: 49

The linear power density thermal limit is designed to prevent melting of the _____ during normal reactor plant operation; the limit is dependent on the axial and radial peaking factors, of which the _____ peaking factor is normally the most limiting.

- A. fuel clad; axial
- B. fuel clad; radial
- C. fuel pellets; axial
- D. fuel pellets; radial

QUESTION: 50

Two identical nuclear reactors are currently shut down for refueling. Reactor A has an average lifetime power capacity of 60% and has been operating for 15 years. Reactor B has an average lifetime power capacity of 75% and has been operating for 12 years.

Which reactor, if any, will have the lowest reactor vessel nil ductility transition temperature?

- A. Reactor A due to the lower average lifetime power capacity.
- B. Reactor B due to the higher average lifetime power capacity.
- C. Both reactors will have approximately the same nil ductility transition temperature because each core has produced approximately the same number of fissions.
- D. Both reactors will have approximately the same nil ductility transition temperature because fast neutron irradiation in a shut down core is not significant.

*****FINAL ANSWER KEY *****

**DECEMBER 2007 NRC GENERIC FUNDAMENTALS EXAMINATION
PRESSURIZED WATER REACTOR - ANSWER KEY**

<u>FORM A</u>	<u>FORM B</u>	<u>ANS.</u>	<u>FORM A</u>	<u>FORM B</u>	<u>ANS.</u>
1	15	A	26	40	A or C
2	16	A	27	41	B
3	17	D	28	42	A or C
4	18	A	29	43	B
5	19	D	30	44	C
6	20	C	31	45	B
7	21	A	32	46	D
8	22	A	33	47	D
9	23	B	34	48	D
10	24	C	35	49	B
11	25	C	36	50	A
12	26	A	37	1	B
13	27	D	38	2	B
14	28	B	39	3	A
15	29	C	40	4	B
16	30	D	41	5	A
17	31	A	42	6	D
18	32	C	43	7	A
19	33	C	44	8	B
20	34	D	45	9	D
21	35	C	46	10	D
22	36	D	47	11	D
23	37	B	48	12	C
24	38	C	49	13	D
25	39	B	50	14	C