

ENCLOSURE 3

(WCAP-13301)

9207170083 920717
PDR ADOCK 05000390
A PDR

WCAP-13301

WESTINGHOUSE PROPRIETARY CLASS 3

EVALUATION OF PRESSURIZED THERMAL SHOCK
FOR WATTS BAR UNIT 2

J. M. Chicots
P. L. Strauch

April 1992

Work Performed Under Shop Order WQTP-108

Prepared by Westinghouse Electric Corporation
for Tennessee Valley Authority

Approved by: T. A. Meyer
T. A. Meyer, Manager

Structural Reliability & Plant Life Optimization

WESTINGHOUSE ELECTRIC CORPORATION
Nuclear and Advanced Technology Division
P.O. Box 355
Pittsburgh, Pennsylvania 15230-0355

© 1992 Westinghouse Electric Corporation
All Rights Reserved

TABLE OF CONTENTS

	<u>Page</u>
Table of Contents	i
List of Tables	ii
List of Figures	ii
1. Introduction	1
2. Pressurized Thermal Shock	2
3. Method for Calculation of RT_{PTS}	3
4. Verification of Plant-Specific Material Properties	5
5. Neutron Fluence Values	7
6. Determination of RT_{PTS} Values for All Beltline Region Materials	8
7. Conclusions	10
8. References	11

LIST OF TABLES

<u>Table</u>	<u>Title</u>	<u>Page</u>
1.	Watts Bar Unit 2 Reactor Vessel Beltline Region Material Properties	7
2.	Neutron Exposure Projections at Key Locations on the Watts Bar Unit 2 Pressure Vessel Clad/Base Metal Interface for 32 and 48 EFPY	7
3.	RT _{pTS} Values for Watts Bar Unit 2 for 32 EFPY	9
4.	RT _{pTS} Values for Watts Bar Unit 2 for 48 EFPY	9

LIST OF FIGURES

<u>Figure</u>	<u>Title</u>	<u>Page</u>
1.	Identification and Location of Beltline Region Material for the Watts Bar Unit 2 Reactor Vessel	6
2.	RT _{pTS} versus Fluence Curves for Watts Bar Unit 2 Limiting Material - Circumferential Seam Weld	10

1. INTRODUCTION

A limiting condition on reactor vessel integrity known as pressurized thermal shock (PTS) may occur during a severe system transient such as a loss-of-coolant-accident (LOCA) or a steam line break. Such transients may challenge the integrity of a reactor vessel under the following conditions:

- severe overcooling of the inside surface of the vessel wall followed by high repressurization;
- significant degradation of vessel material toughness caused by radiation embrittlement; and
- the presence of a critical-size defect in the vessel wall.

Fracture mechanics analysis can be used to evaluate reactor vessel integrity under severe transient conditions.

In 1985 the Nuclear Regulatory Commission (NRC) issued a formal ruling on pressurized thermal shock. It established screening criteria on pressurized water reactor (PWR) vessel embrittlement as measured by the nil-ductility reference temperature, termed RT_{PTS} ^[1]. RT_{PTS} screening values were set for beltline axial welds, forgings and plates and for beltline circumferential weld seams for end-of-license life. The screening criteria were determined using conservative fracture mechanics analysis techniques. All PWR vessels in the United States have been required to evaluate vessel embrittlement in accordance with these criteria through end-of-license life. The Nuclear Regulatory Commission has amended its regulations for light water nuclear power plants to change the procedure for calculating radiation embrittlement. The revised PTS Rule was published in the Federal Register, May 15, 1991 with an effective date of June 14, 1991^[2]. This amendment makes the procedure for calculating RT_{PTS} values consistent with the methods given in Regulatory Guide 1.99, Revision 2^[3].

The purpose of this report is to determine the RT_{PTS} values for the Watts Bar Unit 2 reactor vessel and address the revised Pressurized Thermal Shock (PTS) Rule. Section 2 discusses the Rule and its requirements. Section 3 provides the methodology for calculating RT_{PTS} . Section 4 provides the reactor vessel beltline region material properties for the Watts Bar Unit 2 reactor vessel. The neutron fluence values used in this analysis are presented in Section 5. The results of the RT_{PTS} calculations are presented in Section 6. The conclusions and references for the PTS evaluation follow in Sections 7 and 8, respectively.

2. PRESSURIZED THERMAL SHOCK

The PTS Rule requires that the PTS submittal be updated whenever there are changes in core loadings, surveillance measurements or other information that indicates a significant change in projected values.

The Rule outlines regulations to address the potential for PTS events on pressurized water reactor (PWR) vessels in nuclear power plants that are operated with a license from the United States Nuclear Regulatory Commission (USNRC). PTS events have been shown from operating experience to be transients that result in a rapid and severe cooldown in the primary system coincident with a high or increasing primary system pressure. The PTS concern arises if one of these transients acts on the beltline region of a reactor vessel where a reduced fracture resistance exists because of neutron irradiation. Such an event may produce the propagation of flaws postulated to exist near the inner wall surface, thereby potentially affecting the integrity of the vessel.

The Rule establishes the following requirements for all domestic, operating PWRs:

- * All plants must submit projected values of RT_{PTS} for reactor vessel beltline materials by giving values for time of submittal, the expiration date of the operating license, and the projected expiration date if a change in the operating license or renewal has been requested. This assessment must be submitted within six months after the effective date of this Rule if the value of RT_{PTS} for any material is projected to

exceed the screening criteria. Otherwise, it must be submitted with the next update of the pressure-temperature limits, or the next reactor vessel surveillance capsule report, or within 5 years from the effective date of this Rule change, whichever comes first. These values must be calculated based on the methodology specified in this rule. The submittal must include the following:

- 1) the bases for the projection (including any assumptions regarding core loading patterns),
- 2) copper and nickel content and fluence values used in the calculations for each beltline material. (If these values differ from those previously submitted to the NRC, justification must be provided.)

- * The RT_{PTS} (measure of fracture resistance) Screening Criteria for the reactor vessel beltline region is

270°F for plates, forgings, axial welds
300°F for circumferential weld materials

- * The following equations must be used to calculate the RT_{PTS} values for each weld, plate or forging in the reactor vessel beltline.

$$\text{Equation 1: } RT_{PTS} = I + M + \Delta RT_{PTS}$$

$$\text{Equation 2: } \Delta RT_{PTS} = (CF)f^{(0.28-0.10 \log f)}$$

- * All values of RT_{PTS} must be verified to be bounding values for the specific reactor vessel. In doing this each plant should consider plant-specific information that could affect the level of embrittlement.
- * Plant-specific PTS safety analyses are required before a plant is within 3 years of reaching the Screening Criteria, including analyses of alternatives to minimize the PTS concern.
- * NRC approval for operation beyond the Screening Criteria is required.

3. METHOD FOR CALCULATION OF RT_{PTS}

In the PTS Rule, the NRC Staff has selected a conservative and uniform method for determining plant-specific values of RT_{PTS} at a given time.

For the purpose of comparison with the Screening Criteria, the value of RT_{PTS} for the reactor vessel must be calculated for each weld and plate or forging in the beltline region as given below.

$$RT_{PTS} = I + M + \Delta RT_{PTS}, \text{ where } \Delta RT_{PTS} = (CF)f^{(0.28-0.10 \log f)}$$

I = Initial reference temperature (RT_{NDT}) of the unirradiated material

M = Margin to be added to cover uncertainties in the values of initial RT_{NDT} , copper and nickel contents, fluence and calculational procedures. M = 66°F for welds and 48°F for base metal if generic values of I are used.

M = 56°F for welds and 34°F for base metal if measured values of I are used.

f = Neutron fluence, n/cm^2 ($E > 1\text{MeV}$ at the clad/base metal interface), divided by 10^{19}

CF = Chemistry factor from tables^[2] for welds and for base metal (plates and forgings). If plant-specific surveillance data has been deemed credible per Reg. Guide 1.99, Rev. 2, it may be considered in the calculation of the chemistry factor.

4. VERIFICATION OF PLANT-SPECIFIC MATERIAL PROPERTIES

Before performing the pressurized thermal shock evaluation, a review of the latest plant-specific material properties was performed.

The beltline region is defined by the PTS Rule^[2] to be "the region of the reactor vessel (shell material including welds, heat affected zones and plates or forgings) that directly surrounds the effective height of the active core and adjacent regions of the reactor vessel that are predicted to experience sufficient neutron irradiation damage to be considered in the selection of the most limiting material with regard to radiation damage." Figure 1 identifies and indicates the location of all beltline region materials for the Watts Bar Unit 2 reactor vessel.

Material property values were derived from vessel fabrication material certifications. Fast neutron irradiation-induced changes in the tension, fracture and impact properties of reactor vessel materials are largely dependent on chemical composition, particularly in the copper concentration. The variability in irradiation-induced property changes, which exists in general, is compounded by the variability of copper concentration with the weldments.

A summary of the pertinent chemical and mechanical properties of the beltline region plate and weld materials of the Watts Bar Unit 2 reactor vessel are given in Table 1. All of the initial RT_{NDT} values (I-RTNDT) are also presented in Table 1.

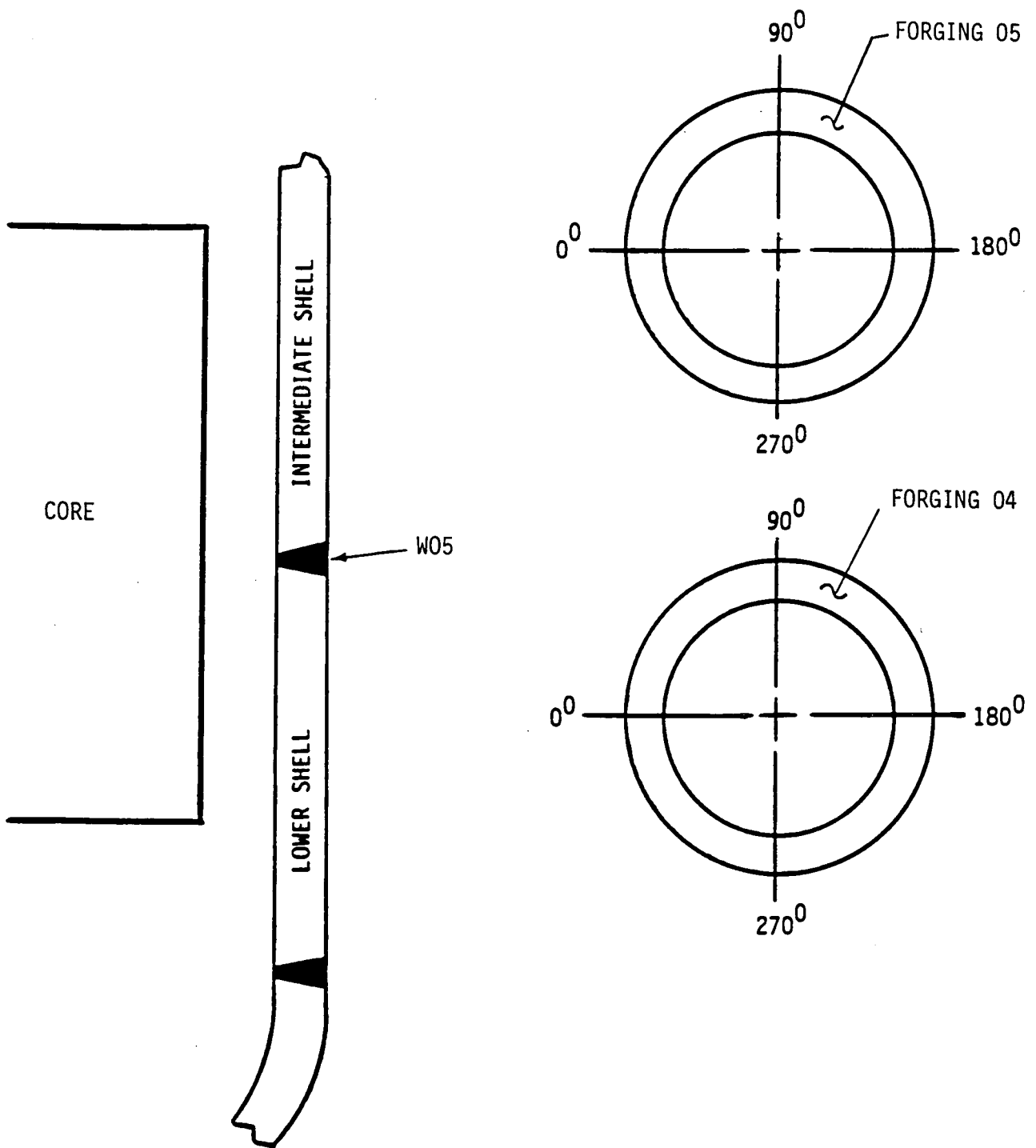

Figure 1. Identification and Location of Beltline Region Material for the Watts Bar Unit 2 Reactor Vessel

TABLE 1
WATTS BAR UNIT 2 REACTOR VESSEL
BELTLINE REGION MATERIAL PROPERTIES

Material Description	CU (%)	NI (%)	I-RTNDT (°F)
Intermediate Shell Forging 05, ASTM A508 CL 2, Heat No. 527828	0.05	0.78	14
Lower Shell Forging 04, ASTM A508 CL2, Heat No. 528658	0.05	0.81	5
Circumferential Weld, W05 Heat No. 895075	0.05	0.70	-50

5. NEUTRON FLUENCE VALUES

The calculated fast neutron fluence ($E > 1$ MeV) at the inner surface of the Watts Bar Unit 2 reactor vessel is shown in Table 2. These values were projected based upon design basis fluence values.

TABLE 2
NEUTRON EXPOSURE PROJECTIONS* AT KEY LOCATIONS ON THE WATTS BAR UNIT 2
PRESSURE VESSEL CLAD/BASE METAL INTERFACE FOR 32 AND 48 EFPY

EFPY	0°	15°	25°	35°	45°
32	1.89	2.81	3.18	2.59	2.97
48	2.84	4.22	4.77	3.89	4.46

*Fluence x 10^{19} n/cm² ($E > 1.0$ MeV)

6. DETERMINATION OF RT_{PTS} VALUES FOR ALL BELTLINE REGION MATERIALS

Using the prescribed PTS Rule methodology, RT_{PTS} values were generated for all beltline region materials of the Watts Bar Unit 2 reactor vessel as a function of 32 EFPY and 48 EFPY fluence values.

The PTS Rule requires that each plant assess the RT_{PTS} values based on plant specific surveillance capsule data under certain conditions. These conditions are:

- Plant specific surveillance data has been deemed credible as defined in Regulatory Guide 1.99, Revision 2, and
- RT_{PTS} values change significantly. (Changes to RT_{PTS} values are considered significant if the value determined with RT_{PTS} equations (1) and (2), or that using capsule data, or both, exceed the screening criteria prior to the expiration of the operating license, including any renewed term, if applicable, for the plant.)

The use of surveillance capsule data does not apply for Watts Bar Unit 2 since surveillance capsule data is not available at this time.

Tables 3 and 4 provide a summary of the RT_{PTS} values for all beltline region materials for 32 EFPY and 48 EFPY, respectively, using the PTS Rule.

TABLE 3
RT_{PTS} VALUES FOR WATTS BAR UNIT 2 FOR 32 EFY

Material	$\Delta RT_{NDT}(\text{°F}) +$ (CF x FF*)		Initial RT_{NDT} (°F)	Margin (°F)	= RT_{PTS} (°F)
Intermediate Shell	31	1.30	14	34	88
Lower Shell	31	1.30	5	34	79
Circumferential Weld Seam	68	1.30	-50	56	95

* Fluence factor based upon peak inner surface neutron fluence of 3.18×10^{19} n/cm².

TABLE 4
RT_{PTS} VALUES FOR WATTS BAR UNIT 2 FOR 48 EFY

Material	$\Delta RT_{NDT}(\text{°F}) +$ (CF x FF*)		Initial RT_{NDT} (°F)	Margin (°F)	= RT_{PTS} (°F)
Intermediate Shell	31	1.39	14	34	91
Lower Shell	31	1.39	5	34	82
Circumferential Weld Seam	68	1.39	-50	56	101

* Fluence factor based upon peak inner surface neutron fluence of 4.77×10^{19} n/cm².

7. CONCLUSIONS

As shown in Tables 3 and 4, all the RT_{PTS} values remain below the NRC screening values for PTS using the projected fluence values for both 32 EFPY and 48 EFPY. A plot of the RT_{PTS} values versus the fluence are shown in Figure 2 for the most limiting material, the circumferential seam weld, in the Watts Bar Unit 2 reactor vessel beltline region.

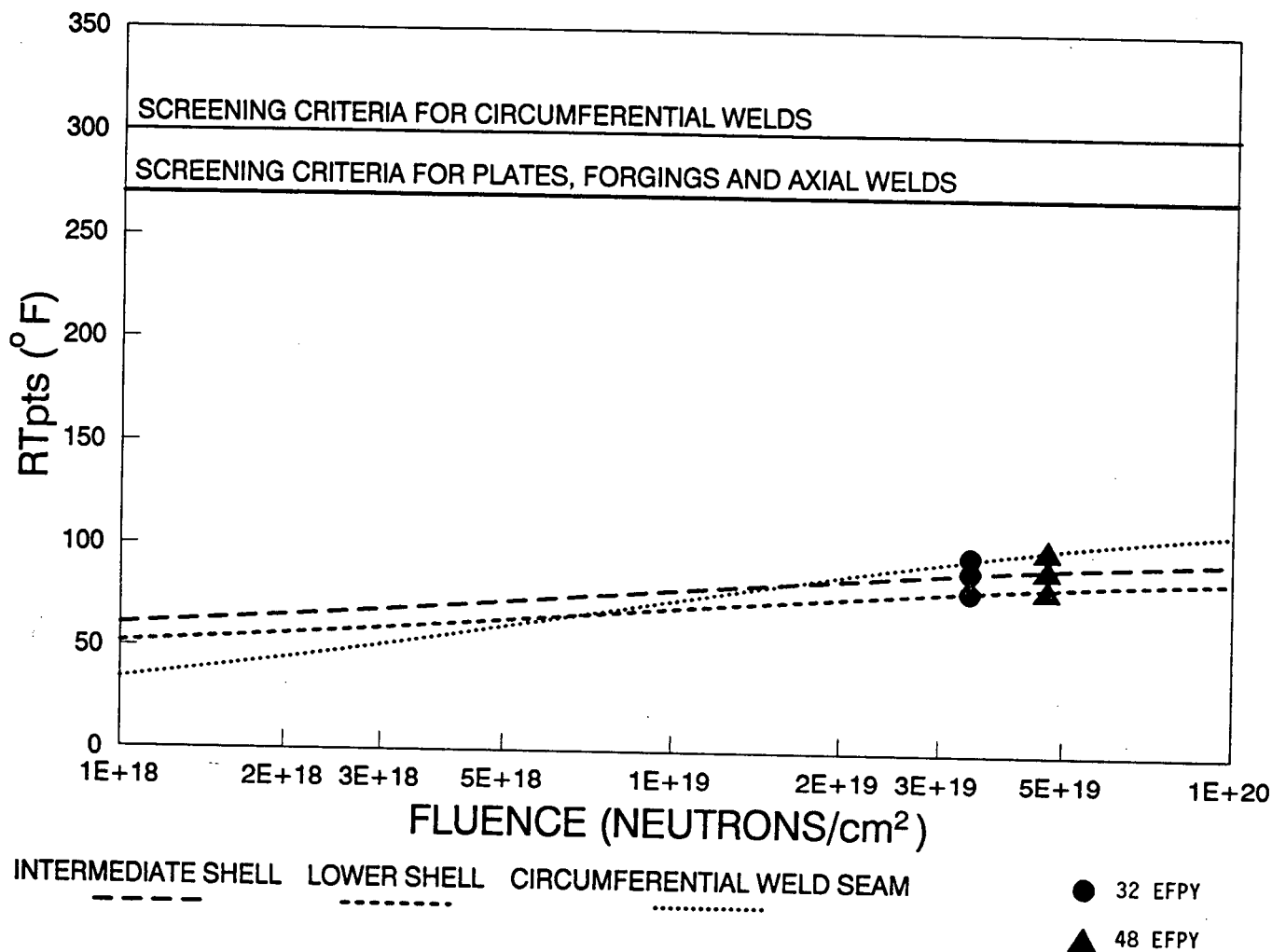

Figure 2. RT_{PTS} versus Fluence Curves for Watts Bar Unit 2
Limiting Material - Circumferential Seam Weld.

8. REFERENCES

- [1] 10CFR Part 50.61, "Analysis of Potential Pressurized Thermal Shock Events," July 23, 1985.
- [2] 10CFR Part 50.61, "Fracture Toughness Requirements for Protection Against Pressurized Thermal Shock Events," May 15, 1991. (PTS Rule)
- [3] Regulatory Guide 1.99, Revision 2, "Radiation Embrittlement of Reactor Vessel Materials," U.S. Nuclear Regulatory Commission, May 1988.
- [4] Watts Bar Final Safety Analysis Report, Section 5.2.
- [5] WCAP-9455, "TVA Watts Bar Unit No. 2, Reactor Vessel Radiation Surveillance Program," March 1979. (Westinghouse Class 3)