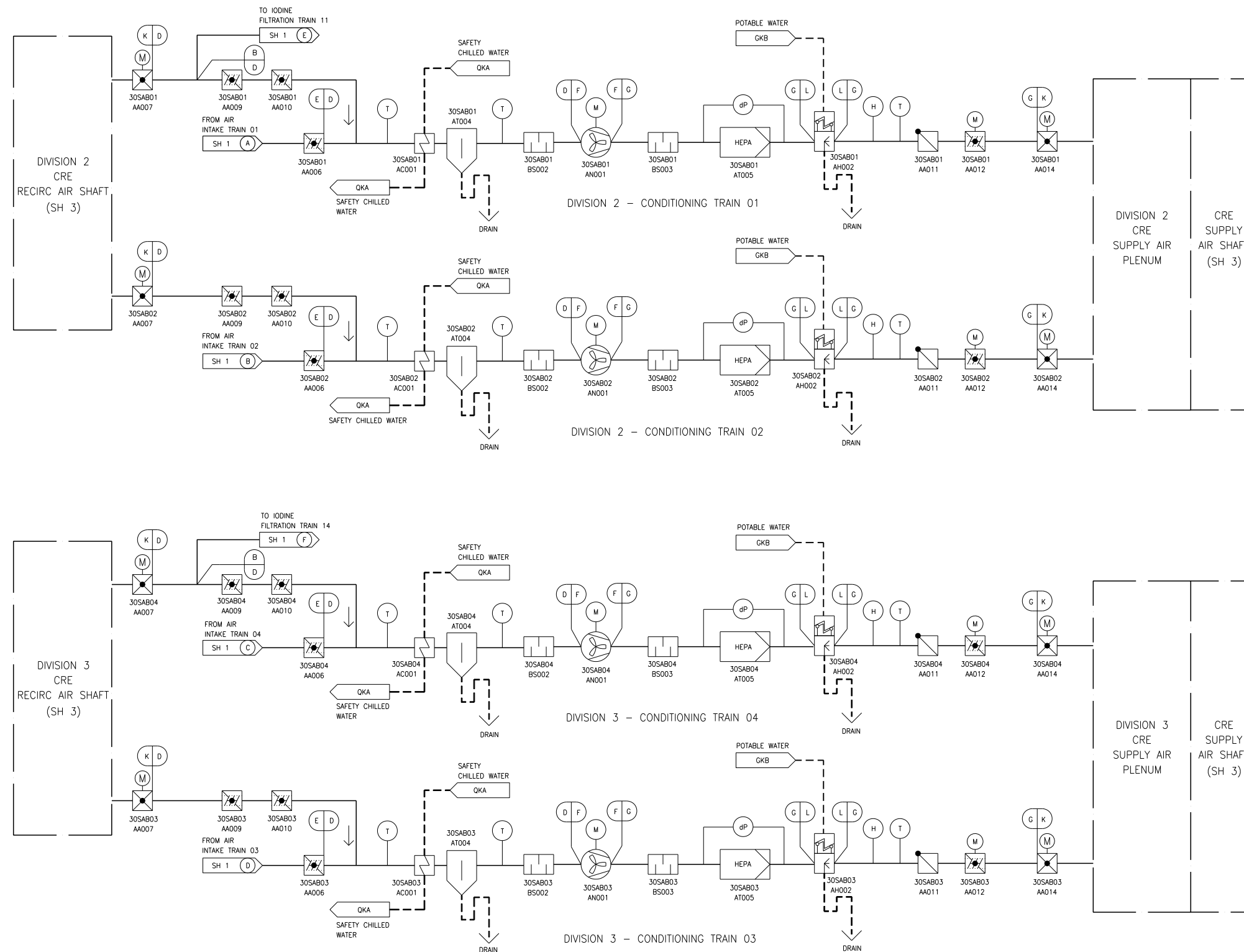

Figure 9.4.1-1—Control Room Air Intake and Iodine Filtration Train Subsystems



GKB - POTABLE AND SANITARY WATER DISTRIBUTION SYSTEM  
 KTE - NUCLEAR ISLAND DRAIN AND VENT SYSTEM  
 QKA - SAFETY CHILLED WATER SYSTEM  
 SAB - MAIN CONTROL ROOM AIR CONDITIONING SYSTEM

L	C	I
K	C	I
G	C	I
F	C	I
E	C	I
D	C	I
B	C	I
DESIGN AREA	SSC QUALITY GROUP	SSC SEISMIC CLASS

SAB02T2

Figure 9.4.1-2—Control Room Recirculation Air Handling Subsystem

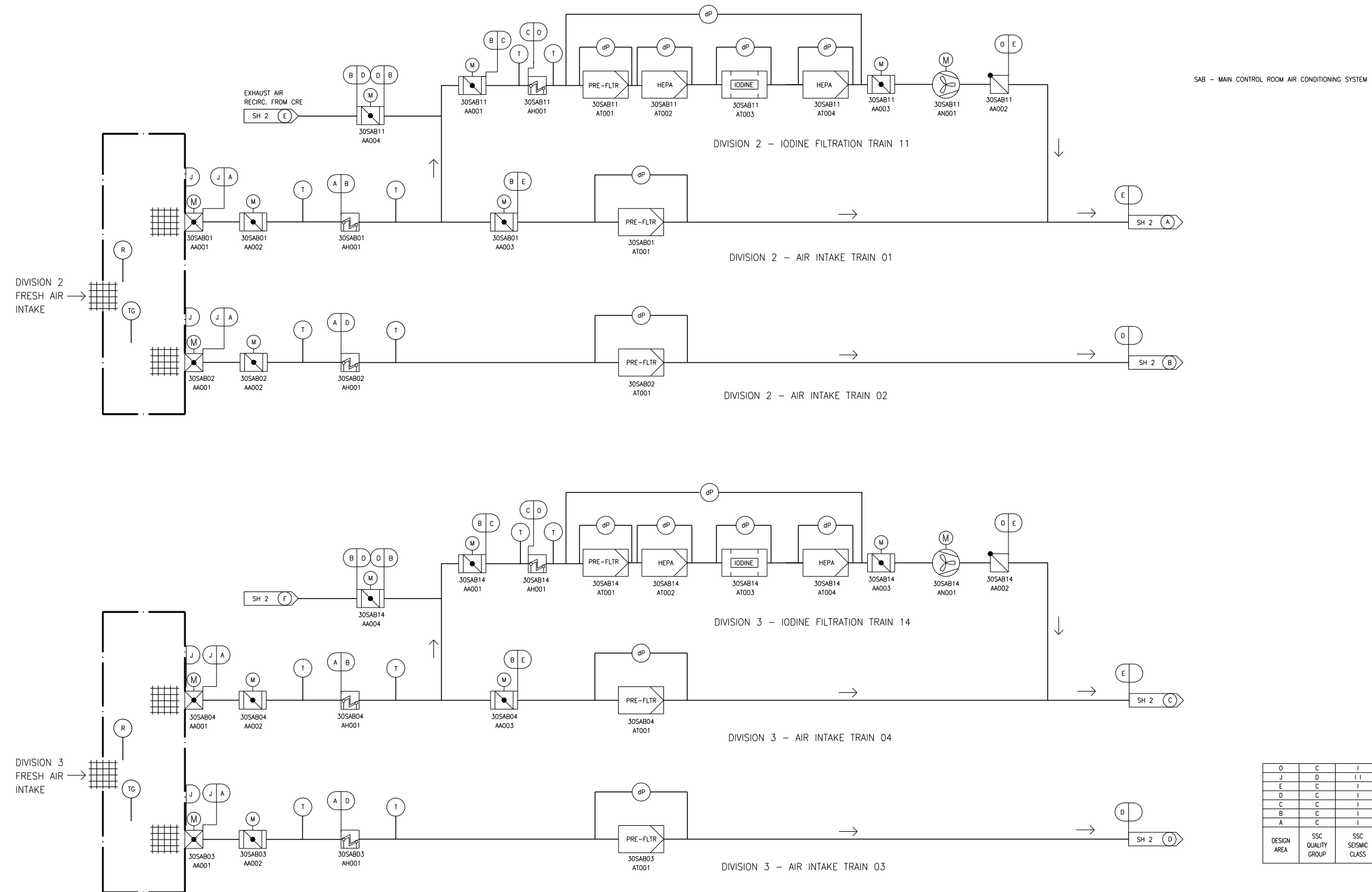

O	C	I
J	D	I I
E	C	I
D	C	I
C	C	I
B	C	I
A	C	I
DESIGN AREA	SSC QUALITY GROUP	SSC SEISMIC CLASS

SAB01T2

Figure 9.4.1-3—Control Room Envelope Air Supply and Recirculation Subsystem

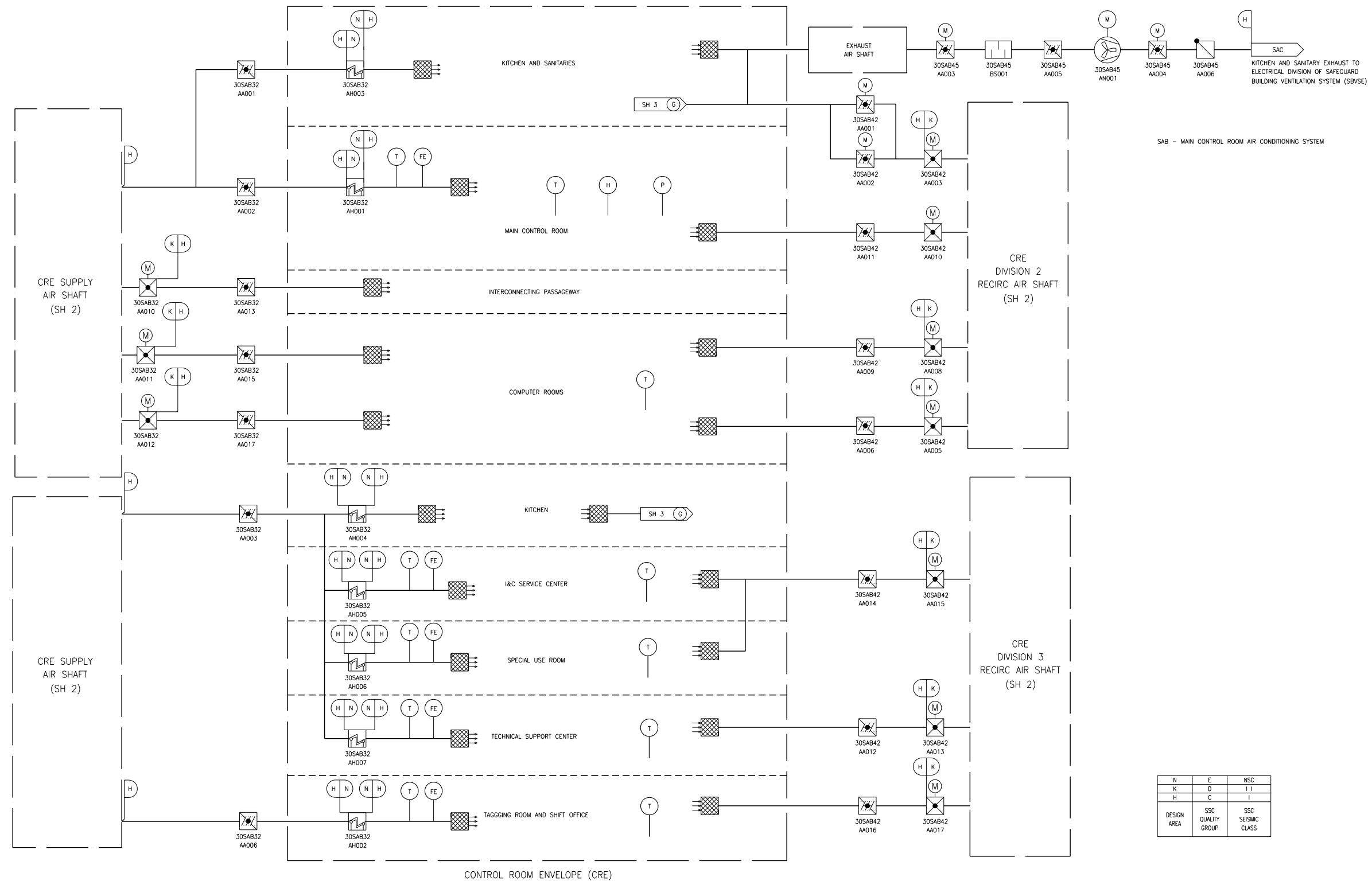

SAB03T2