



UNITED STATES  
NUCLEAR REGULATORY COMMISSION  
WASHINGTON, D. C. 20555

SEP 18 1990

Docket No. 72-9(50-267)

MEMORANDUM FOR: Charles J. Haughney, Chief  
Fuel Cycle Safety Branch  
Division of Industrial and  
Medical Nuclear Safety, NMSS

THRU: John P. Roberts, Section Leader *JPR*  
Irradiated Fuel Section  
Fuel Cycle Safety Branch  
Division of Industrial and  
Medical Nuclear Safety, NMSS

FROM: Steve R. Ruffin, Project Manager  
Irradiated Fuel Section  
Fuel Cycle Safety Branch  
Division of Industrial and  
Medical Nuclear Safety, NMSS

SUBJECT: MEETING WITH PUBLIC SERVICE COMPANY OF COLORADO

DATE/TIME: September 5, 1990; 9:30 a.m.

LOCATION: Room 7B-9, One White Flint North Building, Rockville, Md.

ATTENDEES: See Enclosure 1

PURPOSE: Fort St. Vrain Part 72 License application,  
defueling, and shipping status update

DISCUSSION:

Mr. H. L. Brey, Public Service Company of Colorado (PSC), met with the Fuel Cycle Safety Branch of NMSS to discuss its application for a materials license, under the provisions of 10 CFR Part 72, to possess spent fuel and other radioactive materials associated with spent fuel in an independent spent fuel storage installation (ISFSI). Mr. Brey briefed the staff on the historical and current status of the Fort St. Vrain defueling and shipping perplexity. He also indicated that PSC would like to meet periodically to keep the staff abreast of the current Fort St. Vrain defueling and shipping status (see Enclosure 2) and to remain abreast of the NRC review status of the Fort ISFSI license application. The ISFSI will be located on the Fort St. Vrain site in Weld

9009200166 900918  
PIR ADOCK 05000267  
Y PDC

00134

*[Handwritten signature]*  
NF07

SEP 18 1990

Charles J. Haughney

- 2 -

County, Colorado (see Enclosure 3). The ISFSI will utilize a design based on the FW Energy Applications, Inc., modular vault dry store (MVDS) design and modified to accept high-temperature gas reactor (HTGR) fuel (see Enclosure 4) on the Fort St. Vrain site. The proposed ISFSI capacity may be as much as 1482 HTGR spent fuel blocks.

Original Signed By

Steve R. Ruffin, Project Manager  
Irradiated Fuel Section  
Fuel Cycle Safety Branch  
Division of Industrial and  
Medical Nuclear Safety, NMSS

Enclosures:  
As stated

*See Reports*

Distribution:	Docket File 72-9 (50-267) PDR & LPDR		
NRC File Center	IMSB R/F	IMIF R/F	JRoberts
SRuffin	FSturz	PERickson, NRR	SWeiss, NRR
AHodgdon	FBrown	JDoman	EHylton, NRR
JBBaird, RIV	DLGarrison, RIV		TCJohnson

(SR/MTG FORT ST. VRAIN)

OFC :IMIF	:IMIF	:IMIF
NAME :SRuffin:jc	:FBrown	:JRoberts
DATE :9/17/90	:9/17/90	:9/18/90

OFFICIAL RECORD COPY

SEP 18 1990

Charles J. Haughney

- 3 -

Enclosure 1

ATTENDANCE

<u>NAME</u>	<u>ORGANIZATION</u>
Steve Ruffin	NRC/NMSS
John P. Roberts	NRC/NMSS
Jim Doman	NRC/NMSS
Fritz Sturz	NRC/NMSS
H. L. Brey	PSC

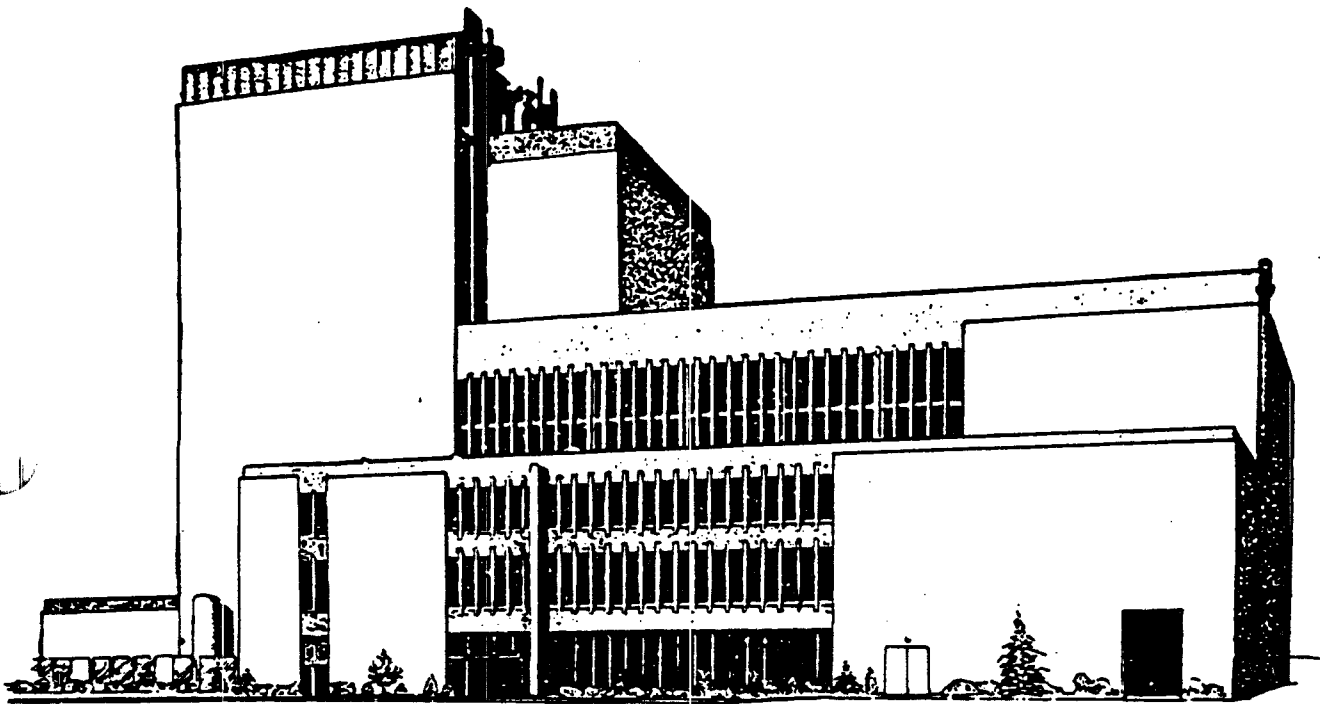

**Fort St. Vrain**

AGENDA FOR NRC MEETING ON THE ISFSI

AUGUST 28, 1990 8:30 AM

FORT ST VRAIN VISITOR CENTER

- I. INTRODUCTION (15 MIN) (MIKE NIEHOFF)
- o STATUS OF DEFUELING/SHIPPING FUEL TO DOE-IDAHO
  - o PSC'S COMMITMENT TO THE ISFSI PROJECT

- II. DISCUSSION OF THE MVDS (60 MIN) (MIKE LEHR)
- o GENERAL OVERVIEW OF THE FORT ST VRAIN PLANT
  - o ISFSI SITE LOCATION
  - o GENERAL OVERVIEW OF THE MVDS DESIGN
  - o REVIEW ISFSI SCHEDULE

----- BREAK -----

- III. TOUR OF FSV REACTOR BUILDING AND ISFSI TRANSPORT ROADWAY  
(2 HRS) (G. REDMOND)

----- LUNCH -----

- IV. TOUR OF ISFSI SITE (60 MIN) (M. LEHR)

- V. QUESTIONS AND DISCUSSION

**FORT ST. VRAIN**

**DEFUELING & FUEL STORAGE OVERVIEW**

**AUGUST 28, 1990**

**BACKGROUND**

- \* **FSV FUEL**
  - **1482 FUEL ELEMENTS**
  - **37 REGIONS**
  - **6 SEGMENTS**
  
- \* **DOE CONTRACT**
  - **ORIGINAL AGREEMENT FOR FSV INCLUDED DRY STORAGE OF THE FIRST 8 SEGMENTS OF FUEL AT DOE IDAHO**
  - **3 SEGMENTS CURRENTLY IN DRY STORE AT IDAHO**
  - **SEGMENTS 4 THROUGH 9 ARE CURRENTLY ON SITE AT FSV**
  - **ONE SEGMENT NOT COVERED BY EXISTING AGREEMENT**

**\* DEFUELING STATUS**

- **SEPTEMBER 1989, GOVERNOR ANDRUS, STATE OF IDAHO PROHIBITED DOE RECEIPT OF FSV SPENT FUEL**
- **DEFUELING STARTED DECEMBER 1989**
- **ONE-THIRD OF CORE OFF LOADED TO FUEL STORAGE WELLS AND TWO SHIPPING CASKS**
- **DEFUELING SUSPENDED FEBRUARY 15, 1990**

**\* CURRENT DOE STATUS**

- **DOE HAS INFORMALLY COMMITTED TO TAKE ALL FSV SPENT FUEL SEGMENTS**
- **SOLUTIONS HAVE BEEN PROMULGATED TO RESOLVE GOVERNOR ANDRUS' CONCERNS**

**\* DOE PROVIDED TENTATIVE TARGET DATES**

- **1 SHIPMENT PER WEEK BEGINNING AUGUST 1990**
- **UP TO 7 SHIPMENTS PER WEEK BEGINNING FEBRUARY 1991**
- **TARGET SHIPPING DATES, IF MET, WILL ALLOW FOR COMPLETION OF DEFUELING BY DECEMBER, 1991**

- \* **PSC COMMITMENT TO THE INDEPENDENT SPENT FUEL STORAGE INSTALLATION (ISFSI)**
  - **TOTAL RELIANCE UPON DOE DEEMED NOT PRUDENT**
  - **FOSTER-WHEELER SELECTED TO DESIGN AND CONSTRUCT THE ISFSI**
  - **NRC PART 72 LICENSE APPLICATION SUBMITTED JUNE 22, 1990**
  - **ANTICIPATE NRC TO ISSUE ENVIRONMENTAL ASSESSMENT BY FEBRUARY 1, 1991**
  - **FACILITY CONSTRUCTION TO BEGIN IN FEBRUARY 1991**
  - **ANTICIPATE NRC TO ISSUE PART 72 LICENSE BY JULY 1, 1991**
  - **CONSTRUCTION TO BE COMPLETE BY NOVEMBER 1991**
  - **DEFUELING TO THE ISFSI TO BE COMPLETE BY MID-1992**



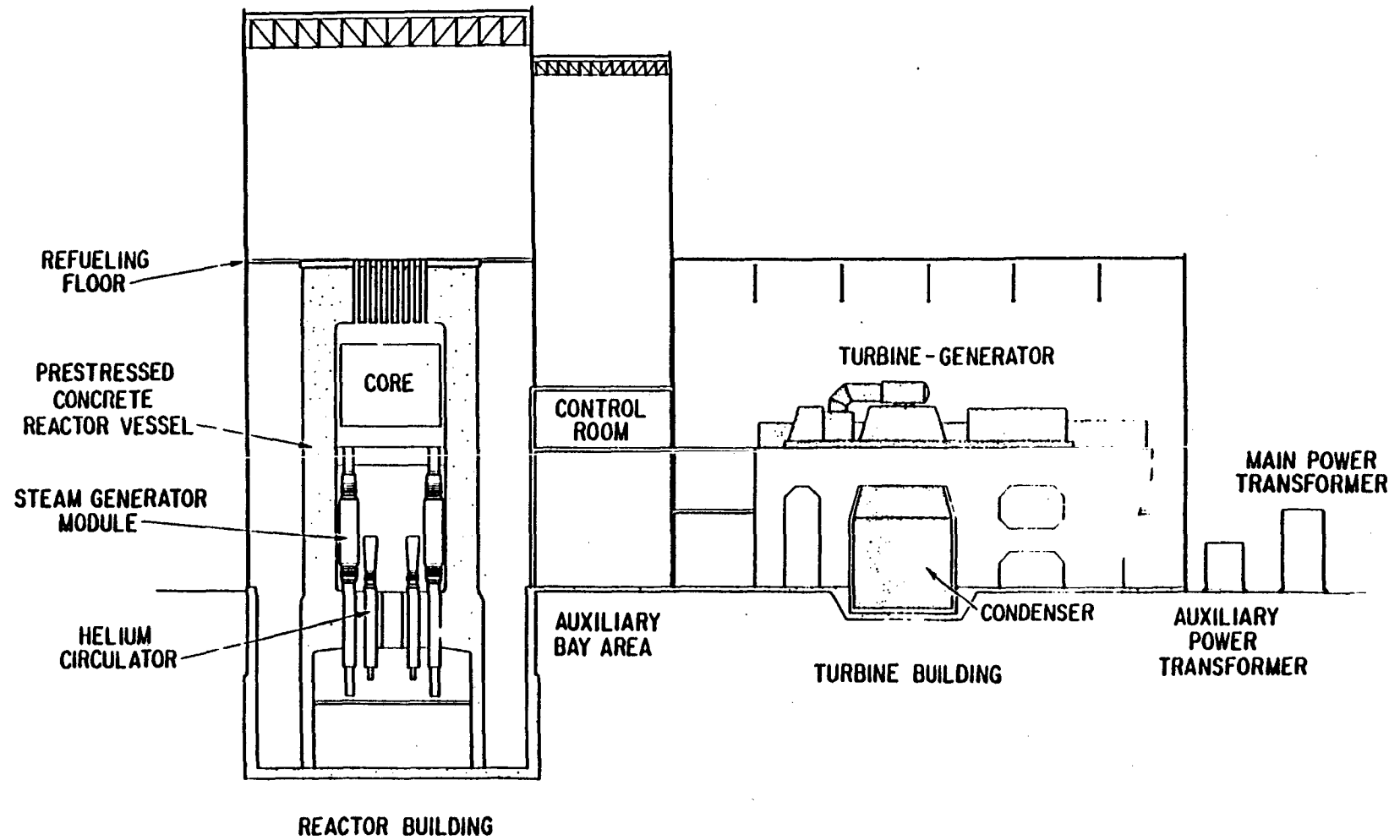

# Reactor Building Cross Section

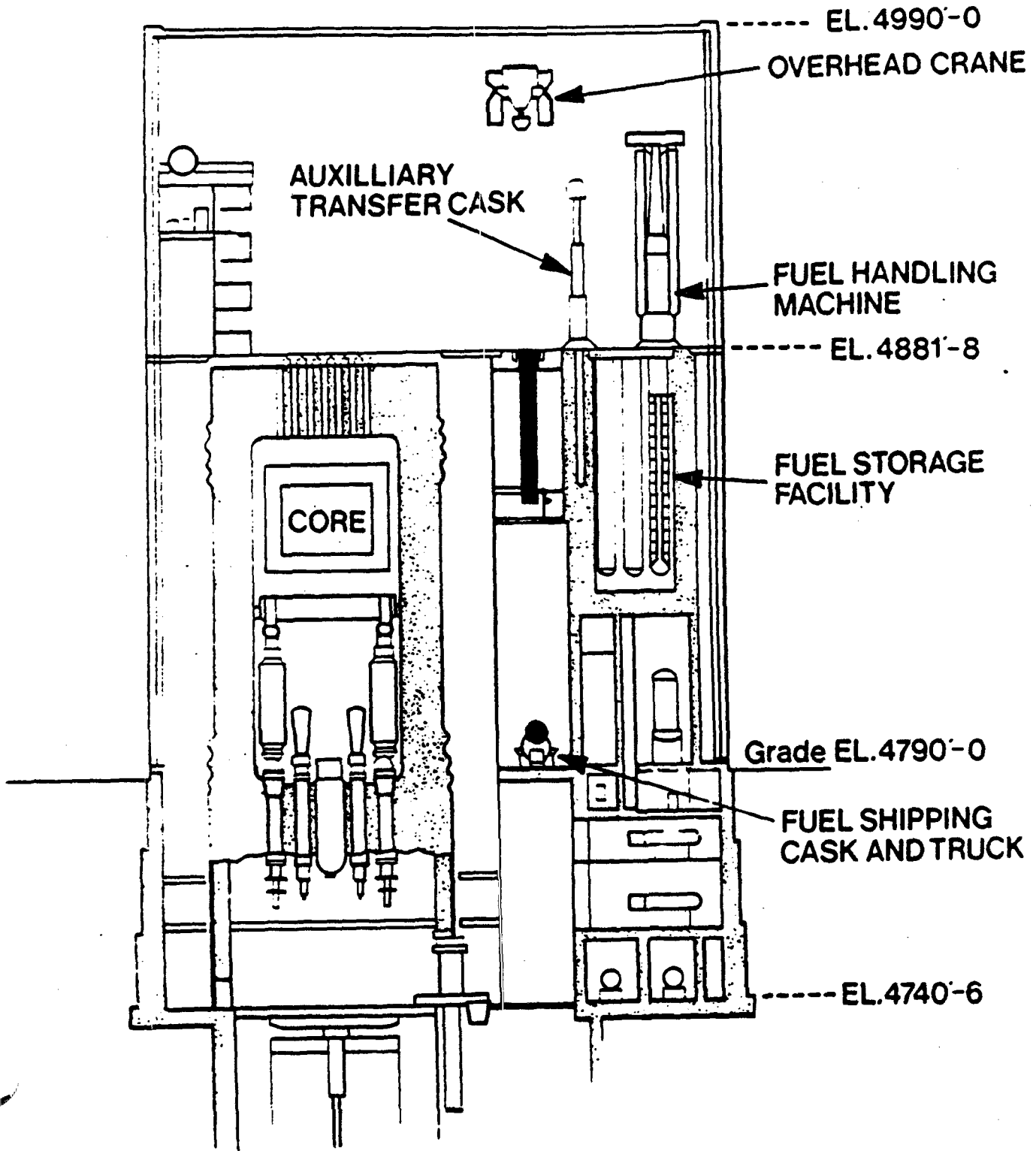

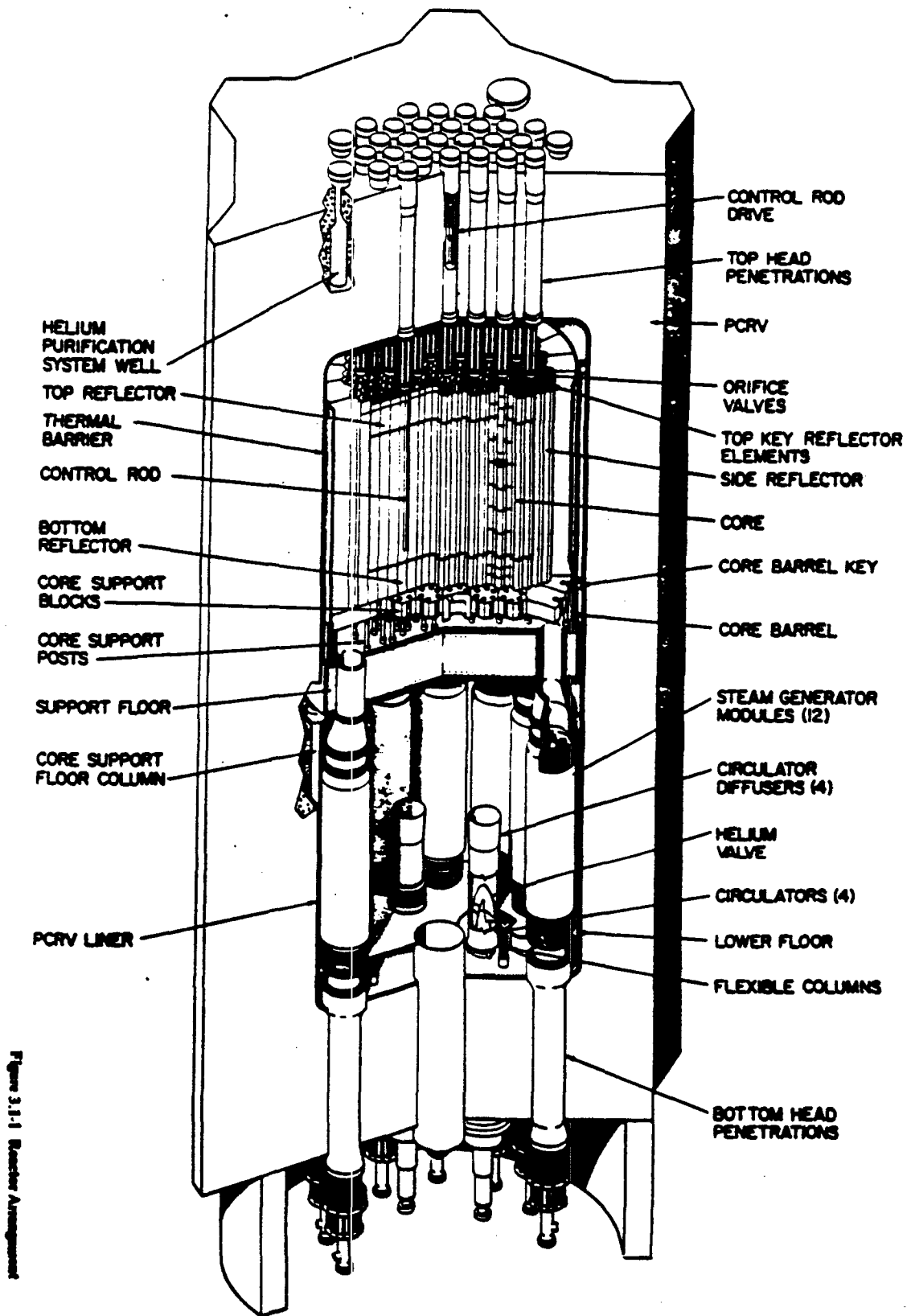
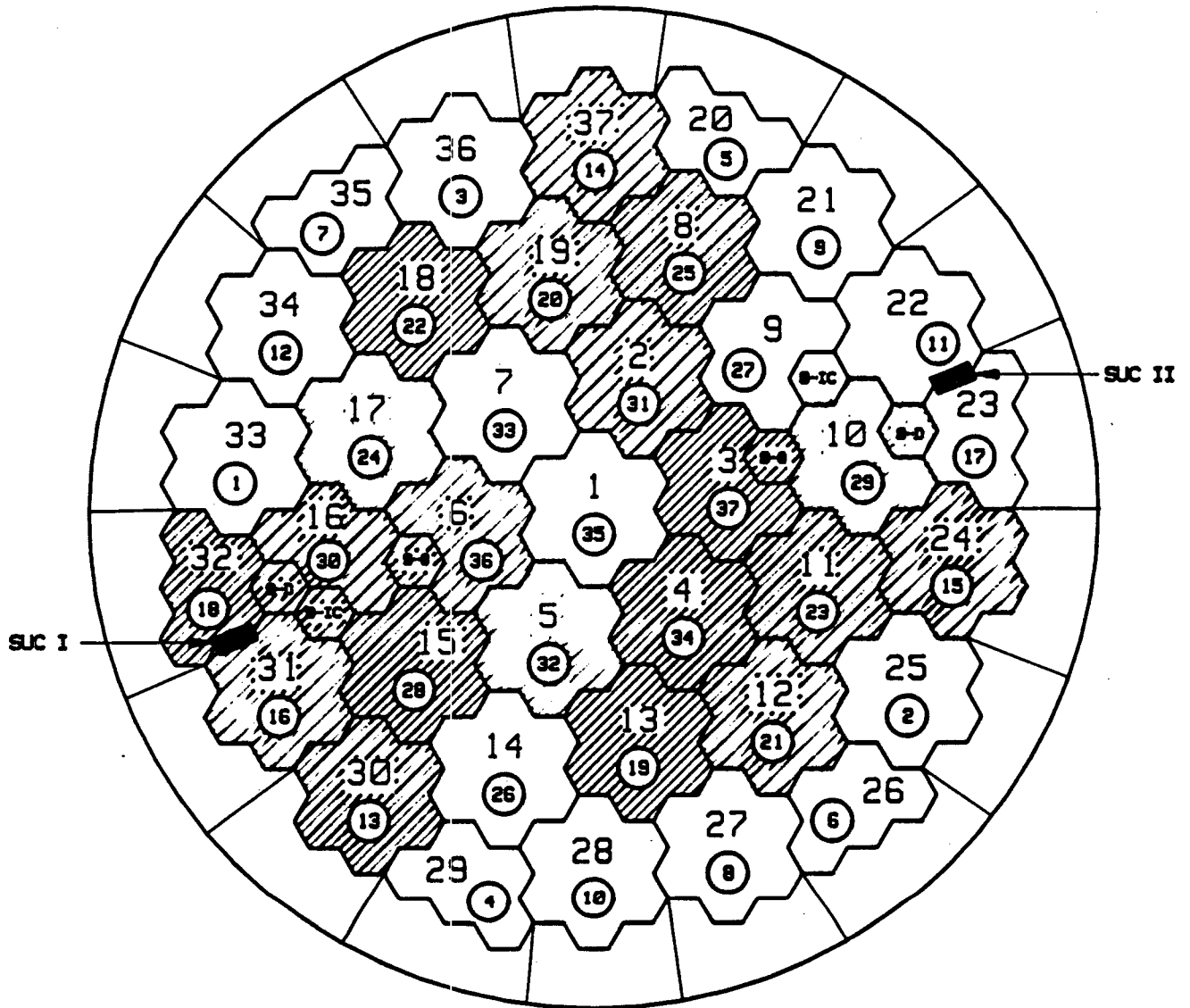

Figure 3.1.1 Reactor Arrangement

# DEFUELING SEQUENCE STRATEGY (SEQUENCE NO. 8)



**LEGEND**

REGION NUMBER 30

SEQUENCE NUMBER 37

SOURCE ELEMENT S-

INITIAL CORE IC

DEFUELING -D

SEGMENT -8 OR -9

**SPIRAL DEFUEL  
(FROM OUTSIDE TO CENTER)**

- |           |        |
|-----------|--------|
| SEGMENT 4 | BLUE   |
| SEGMENT 5 | TEAL   |
| SEGMENT 6 | PURPLE |
| SEGMENT 7 | YELLOW |
| SEGMENT 8 | GREEN  |
| SEGMENT 9 | RED    |

**FIGURE WITHHELD UNDER 10 CFR 2.390**

**FIGURE WITHHELD UNDER 10 CFR 2.390**

**FIGURE WITHHELD UNDER 10 CFR 2.390**

**FIGURE WITHHELD UNDER 10 CFR 2.390**



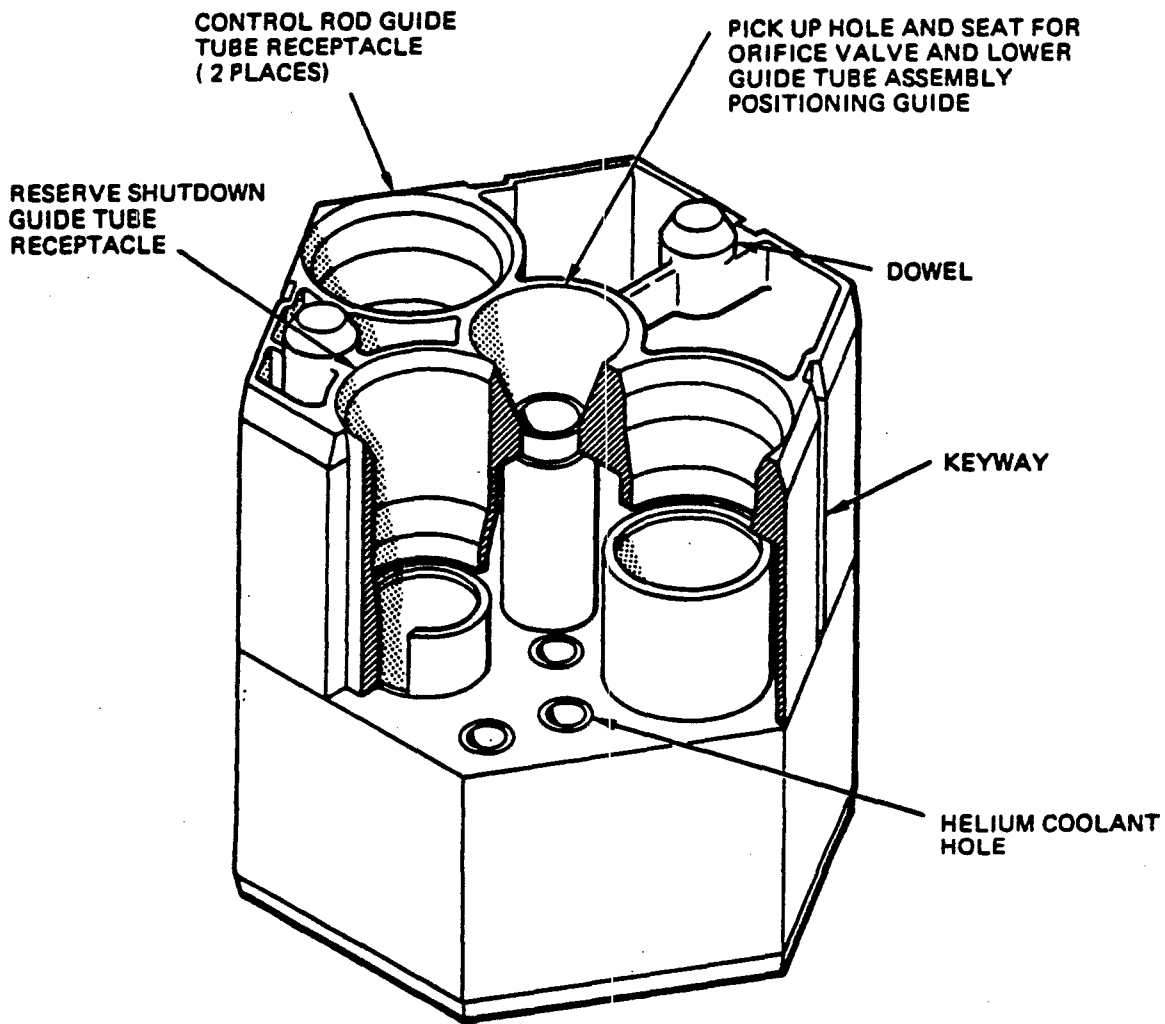
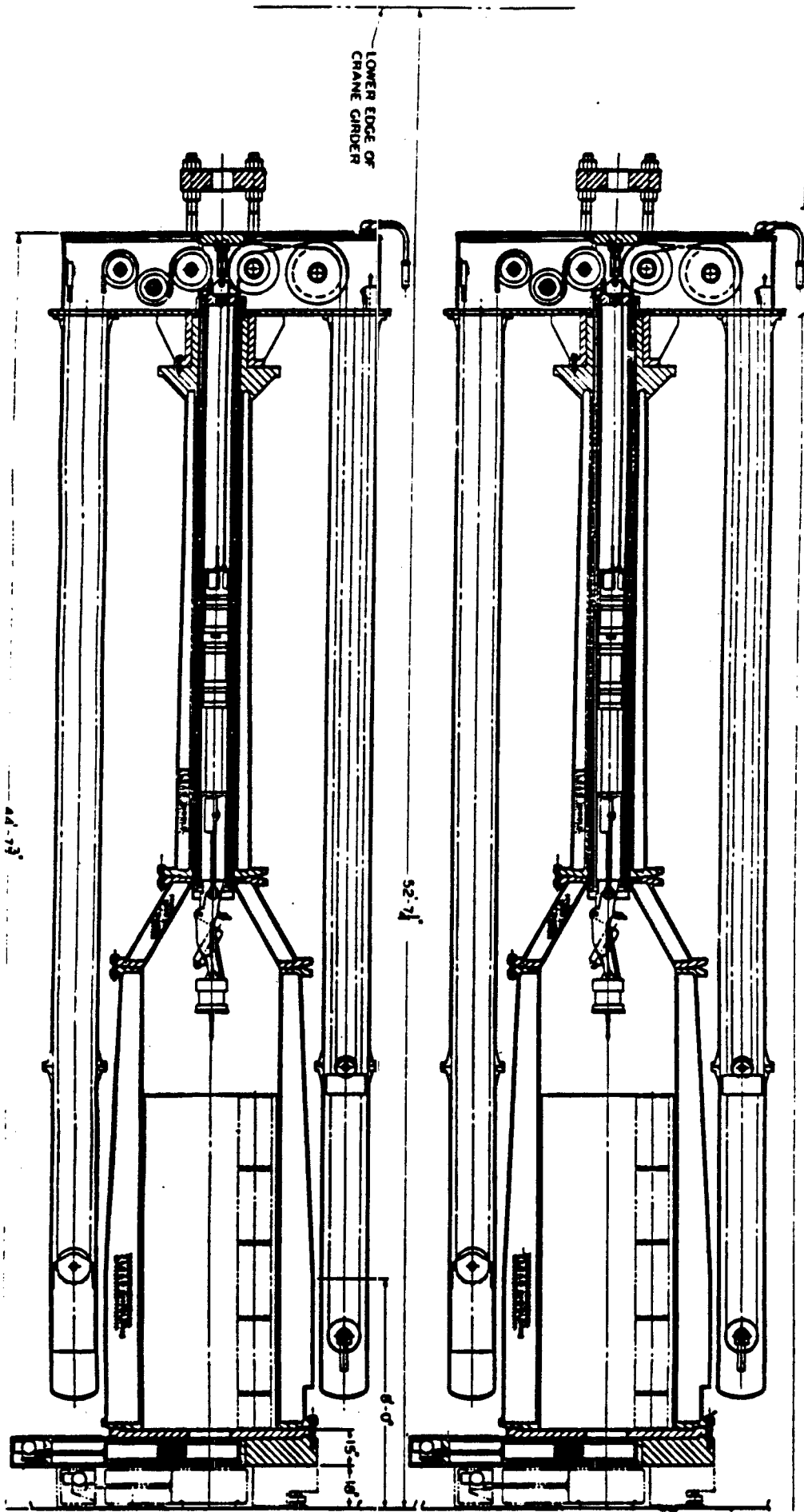
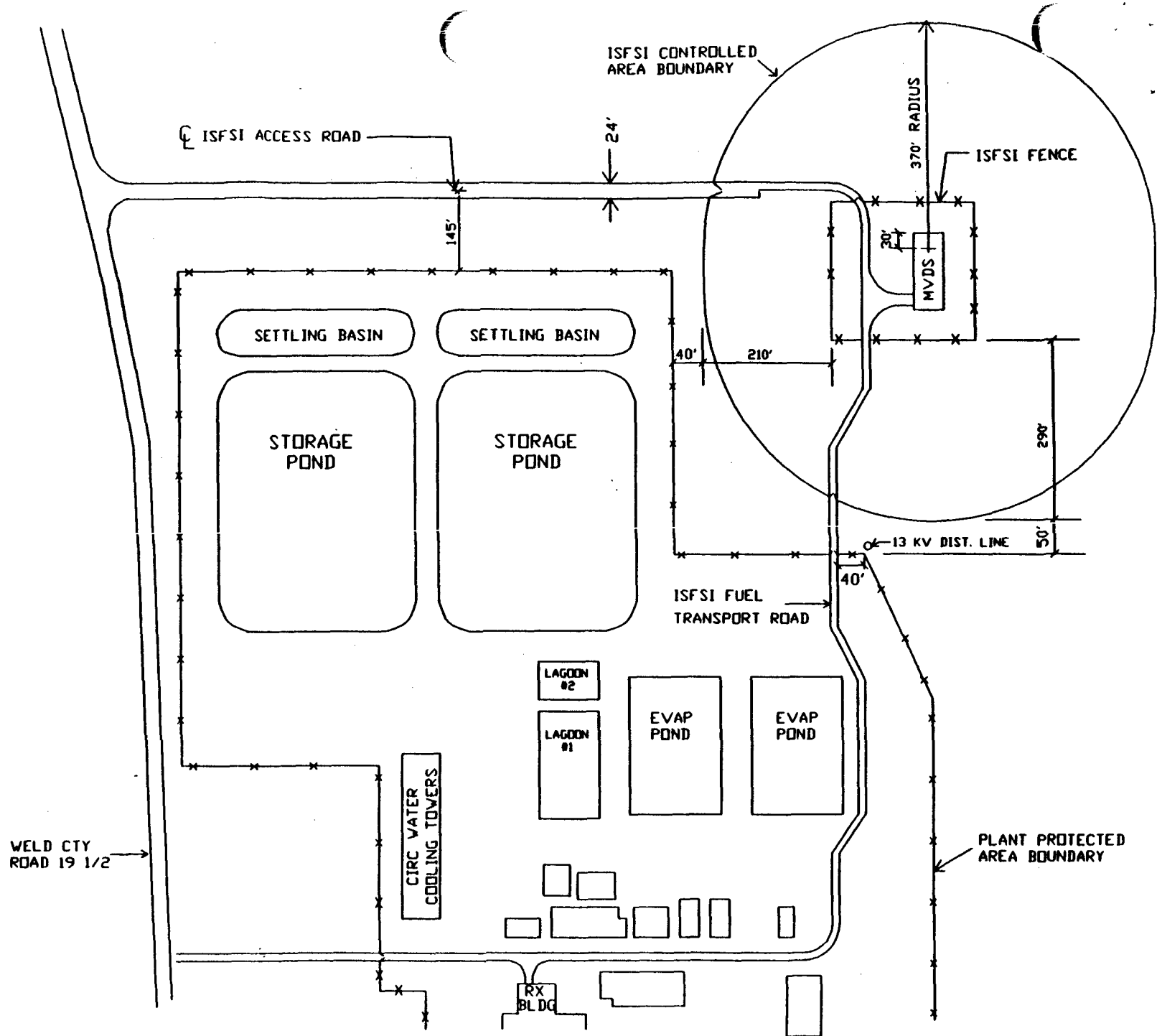
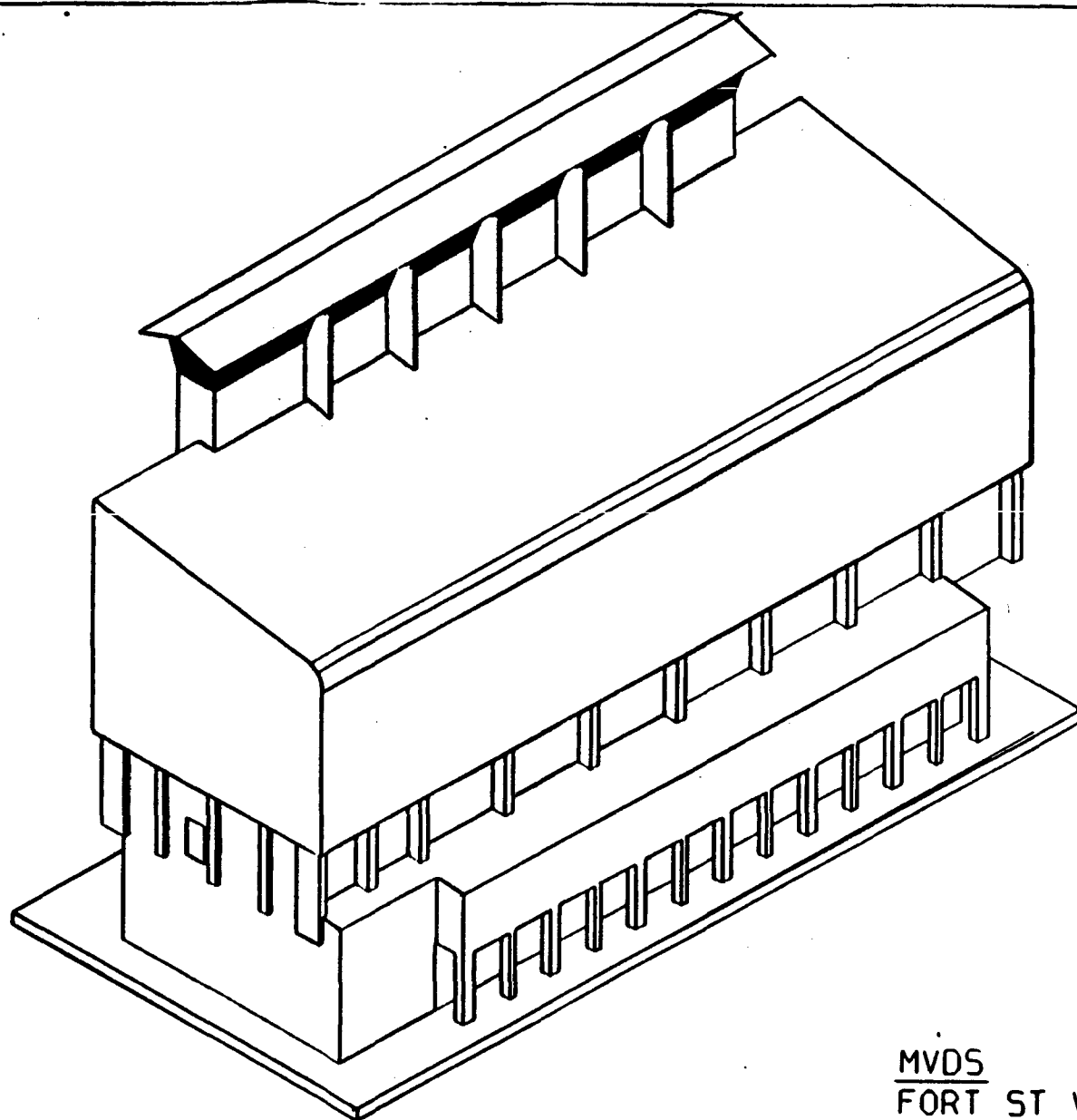

Figure 3.4-6 Keyed Top Reflector Control Rod Element





ISFSI SITE LOCATION PLAN



MVDS  
FORT ST VRAIN

# Fort St. Vrain Shipping Cask

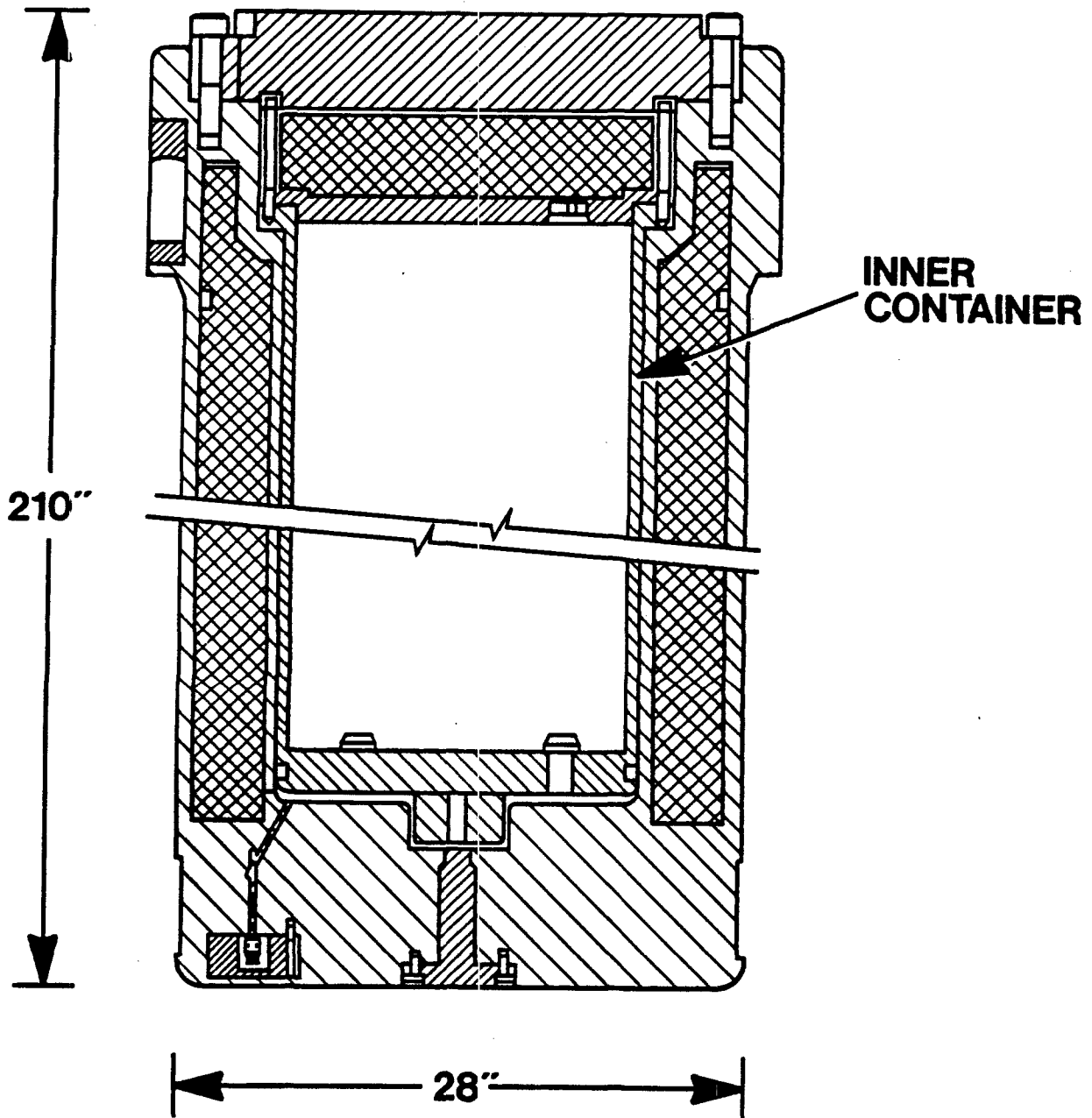

# FSV Shipping Cask (top) WITH STORAGE CONTAINER

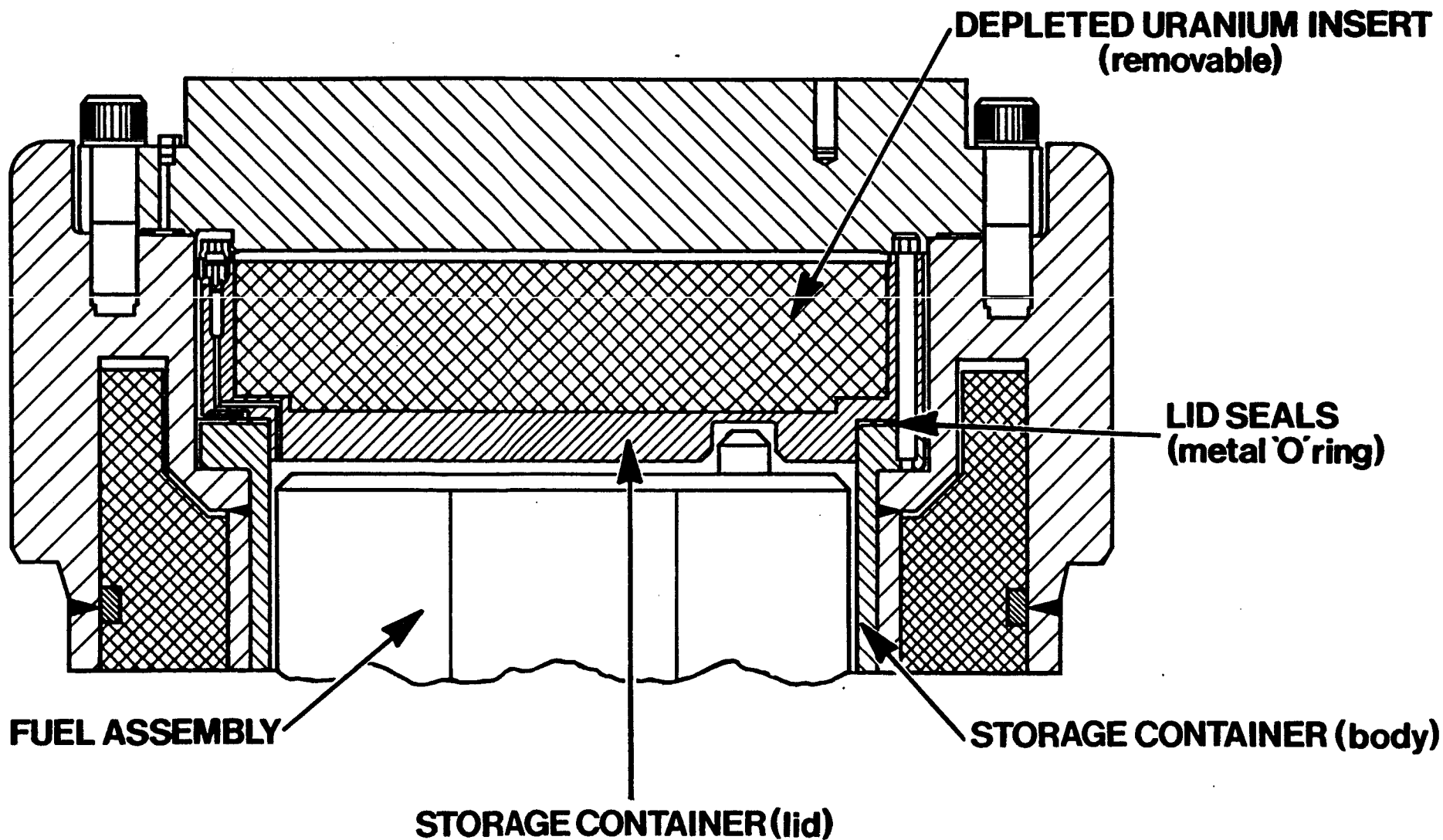

**KEY**

- 1 Cooling Air Inlet
- 2 Civil Structure of the Storage Module
- 3 Storage Container
- 4 Chargeface Structure
- 5 Shield Plugs
- 6 Cask load/unload Position
- 7 Facility Crane
- 8 Weather Enclosure
- 9 Cooling Air Outlet Stack
- 10 Cooling Air Outlet

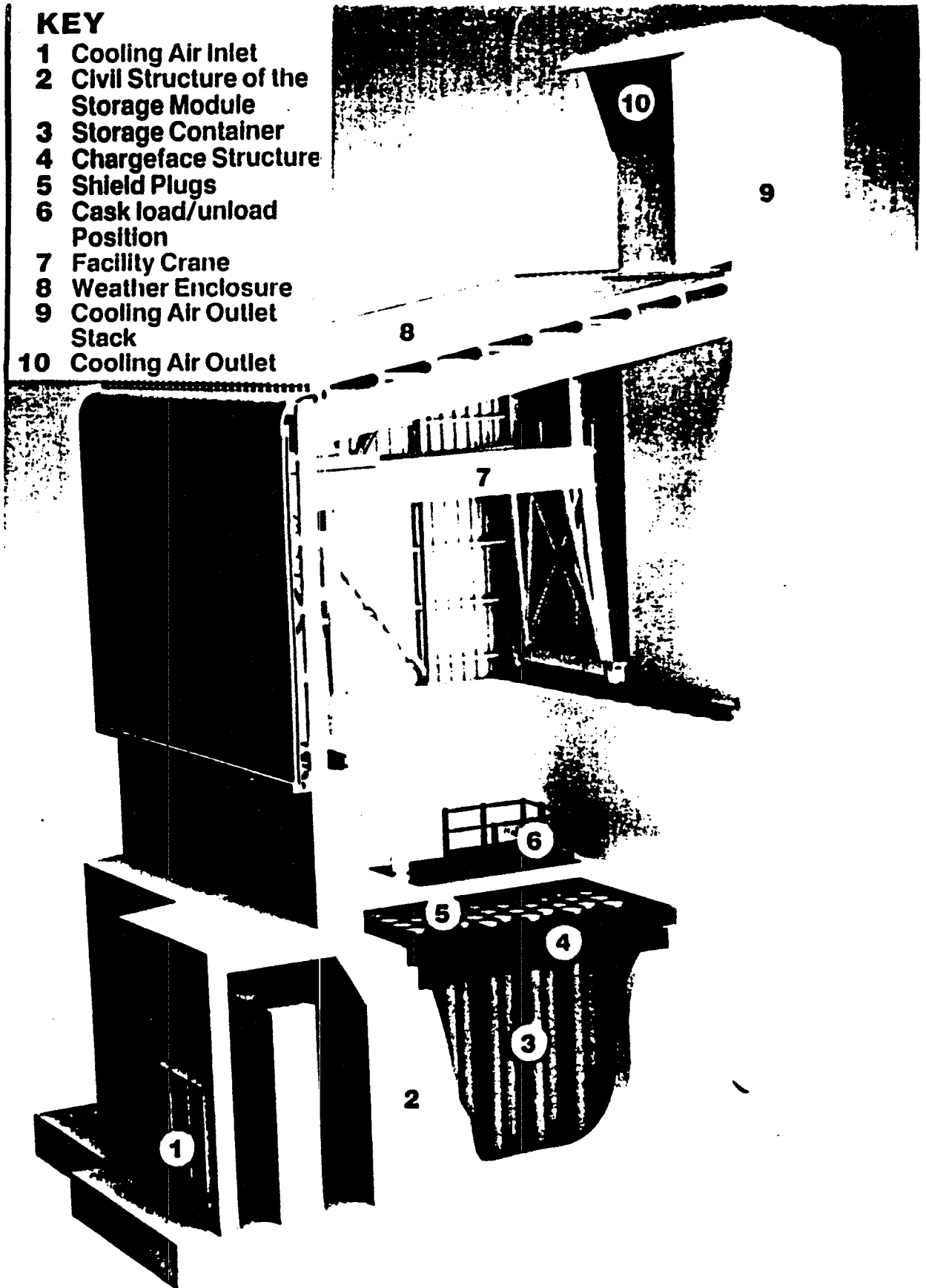

Photograph illustrating a single MVDS Vault Module. This model is representative of the six vault MVDS to be constructed by the Public Service company of Colorado at Fort St Vrain.

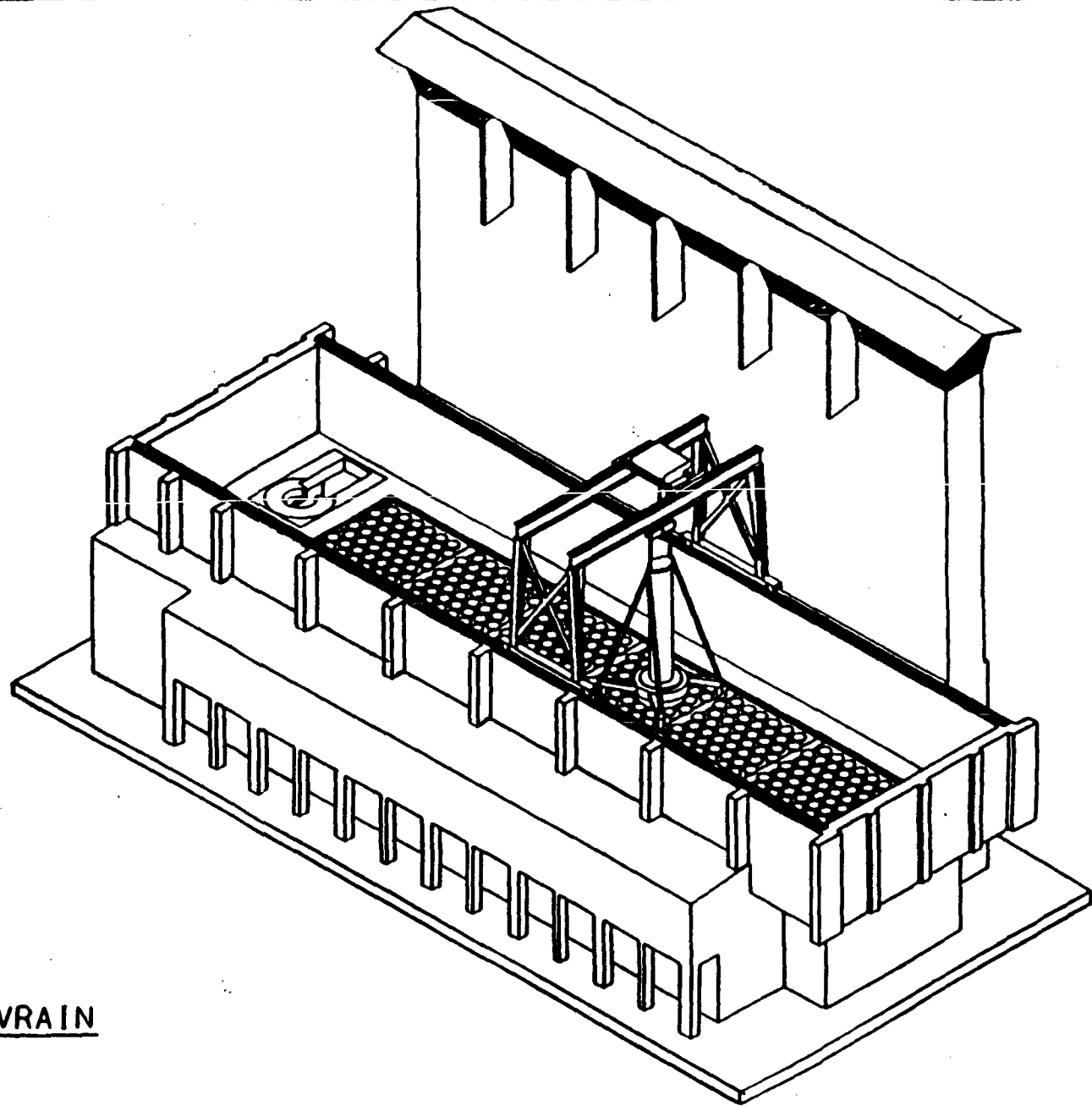

MVDS  
FORT ST VRAIN



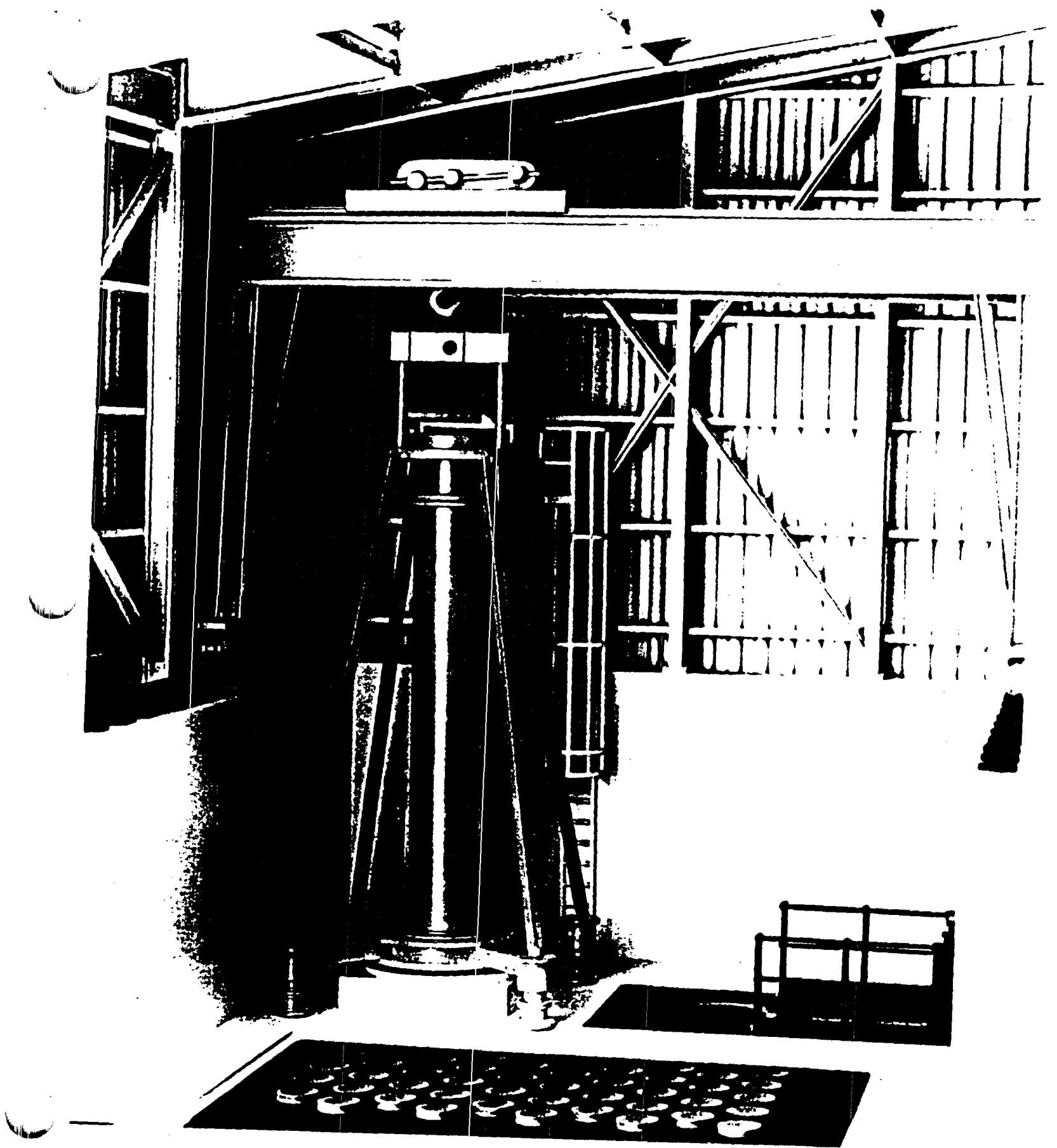

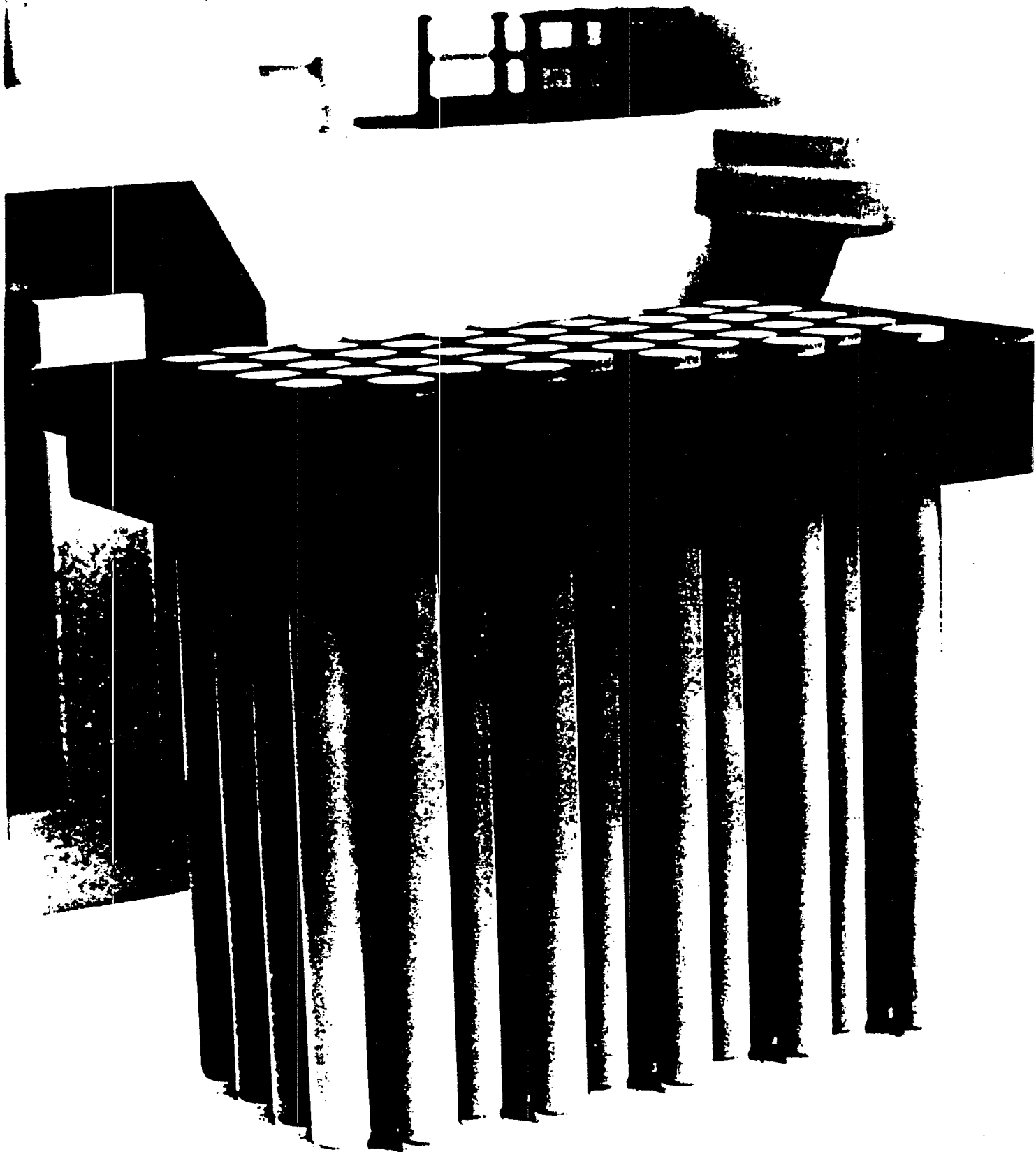

# FSV Storage Vault

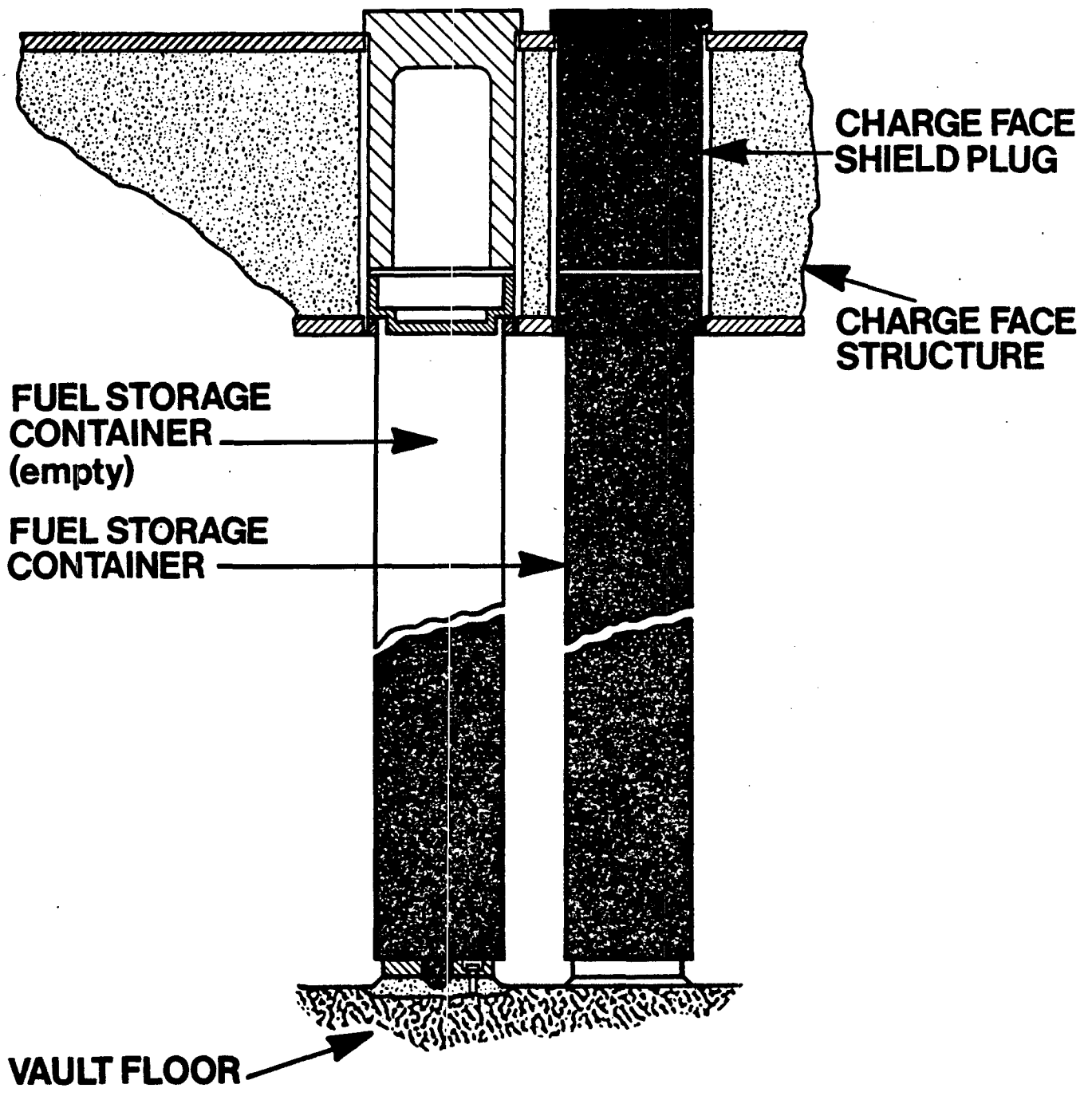

# FSV Storage Vault

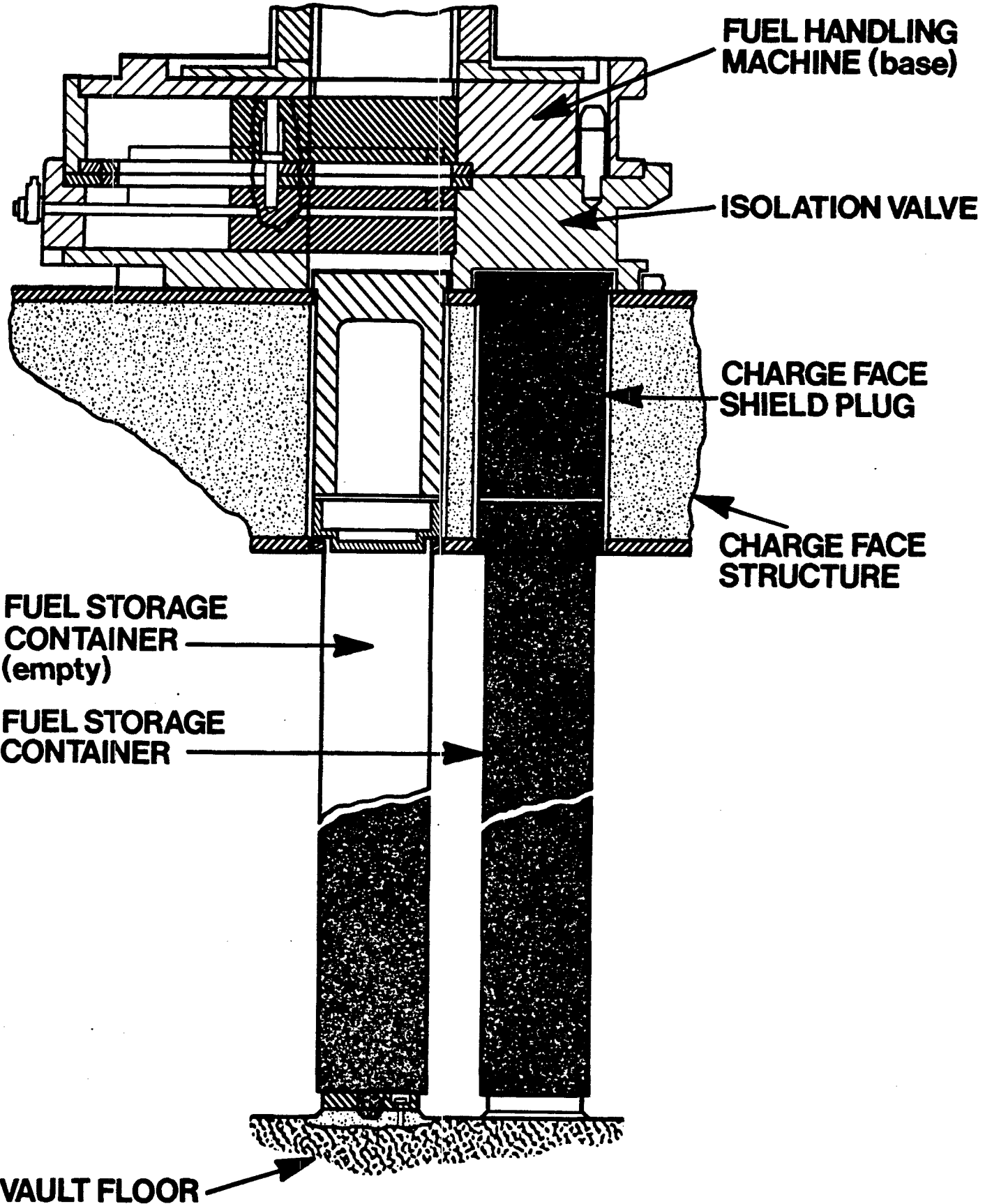

# Modular Vault Dry Store

## GENERAL ARRANGEMENT

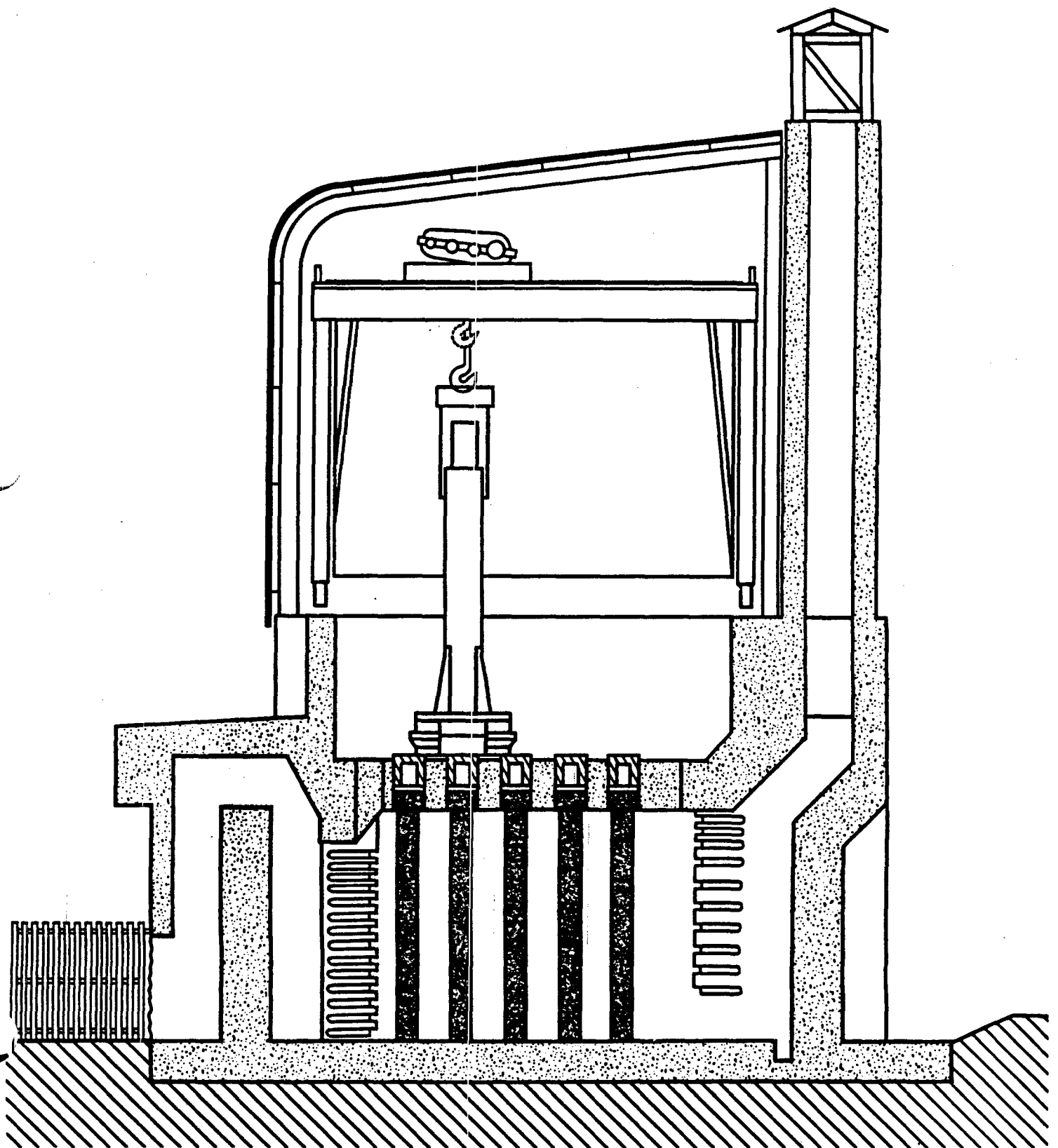



1990

1991

1992

J | F | M | A | M | J | J | A | S | O | N | D | J | F | M | A | M | J | J | A | S | O | N | D | J | F | M | A | M | J

LICENSE APP PREP

RELEASE FOR CONSTRUCTION

NRC REVIEW OF ENV RPT

NRC REVIEW OF SAR AND LICENSE APPLICATION

READY TO LOAD

PROT AREA WORK

CONCRETE WORK

STEEL WORK

INSTALL EQUIPMENT

INSTALL SECURITY SY

TRAINING

AS BUILT DOCUMENTS

DEMONSTRATION TESTING

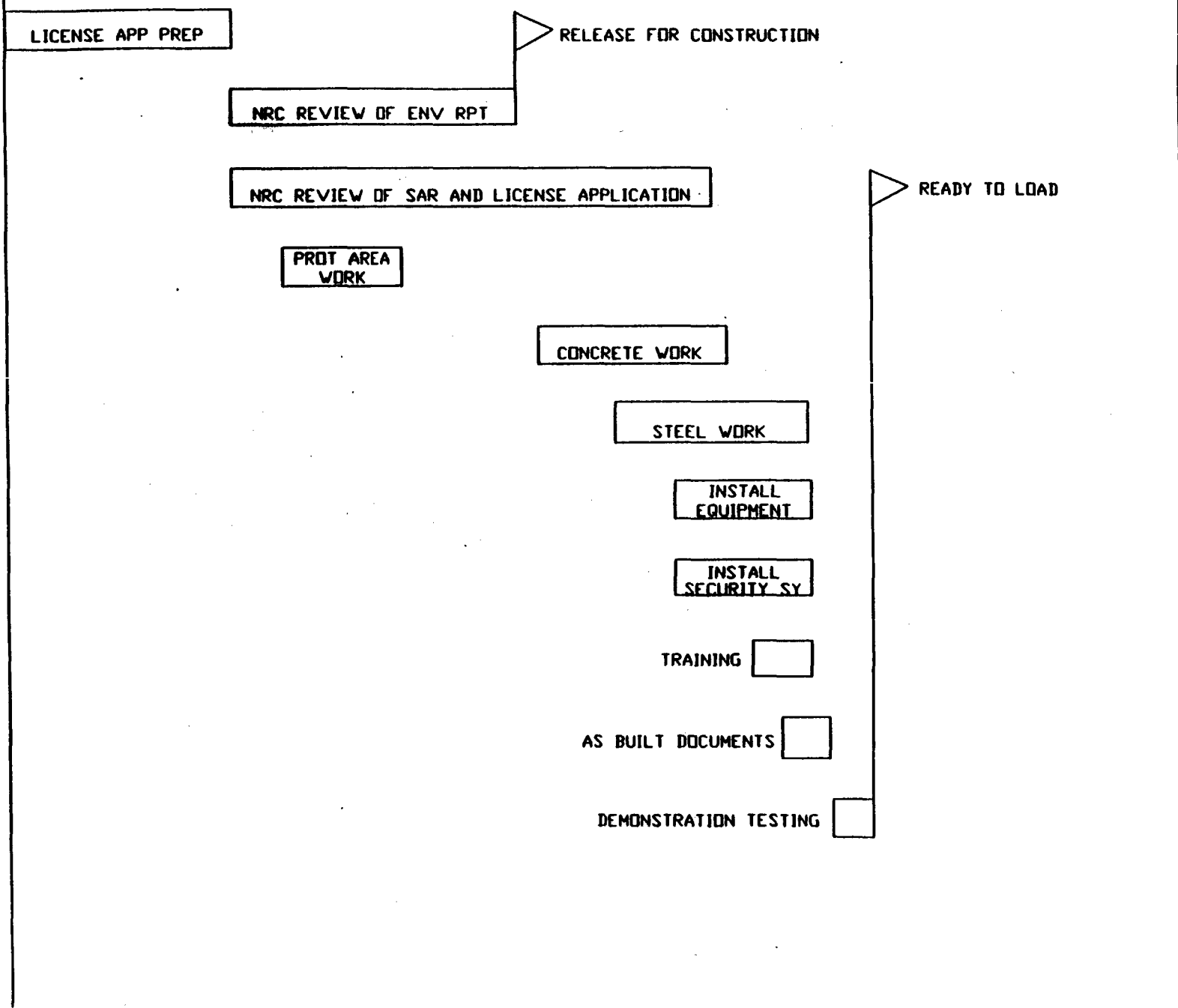

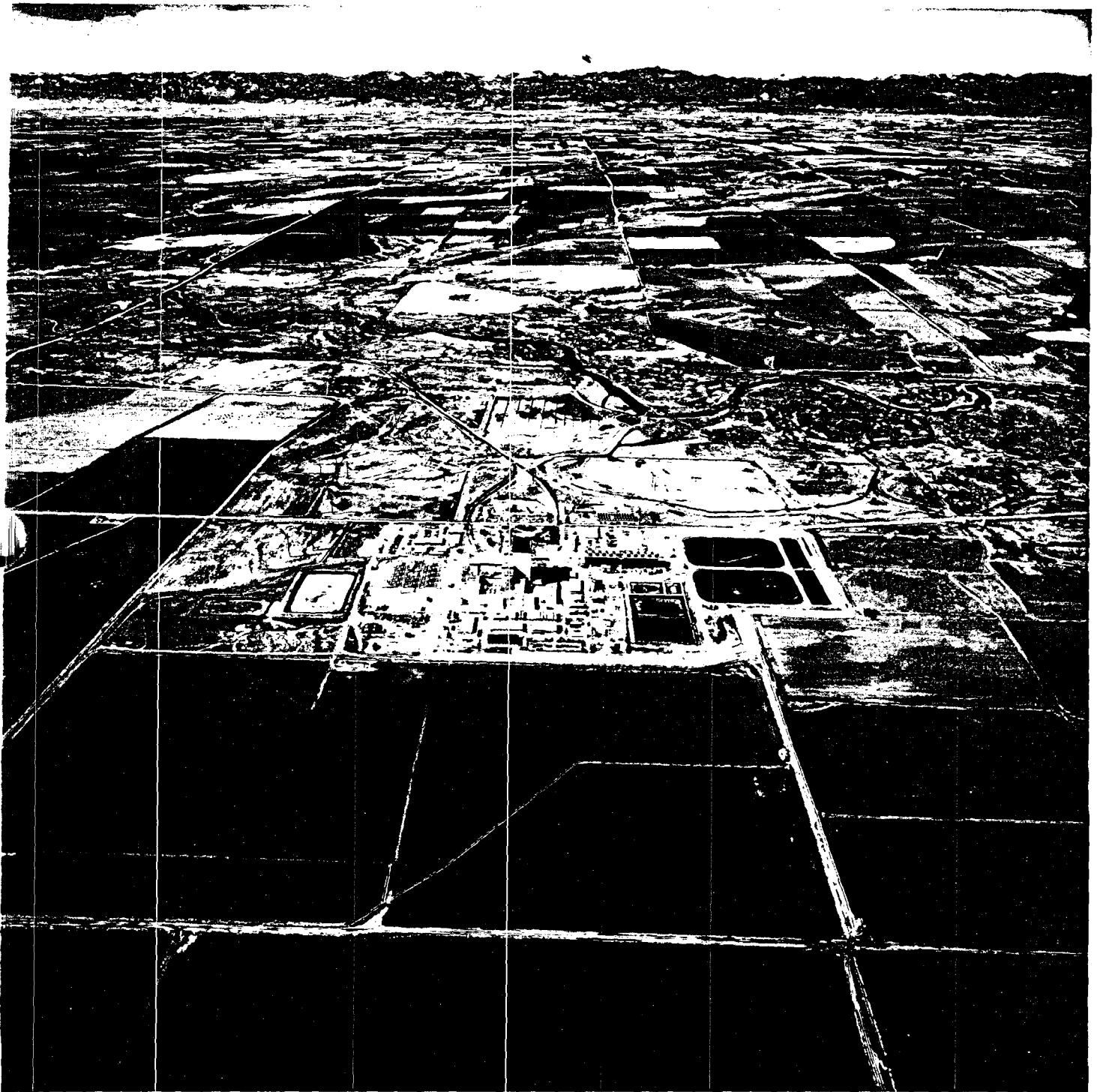



**KEY**

- 1 Cooling Air Inlet
- 2 Civil Structure of the Storage Module
- 3 Storage Container
- 4 Chargeface Structure
- 5 Shield Plugs
- 6 Cask load/unload Position
- 7 Facility Crane
- 8 Weather Enclosure
- 9 Cooling Air Outlet Stack
- 10 Cooling Air Outlet

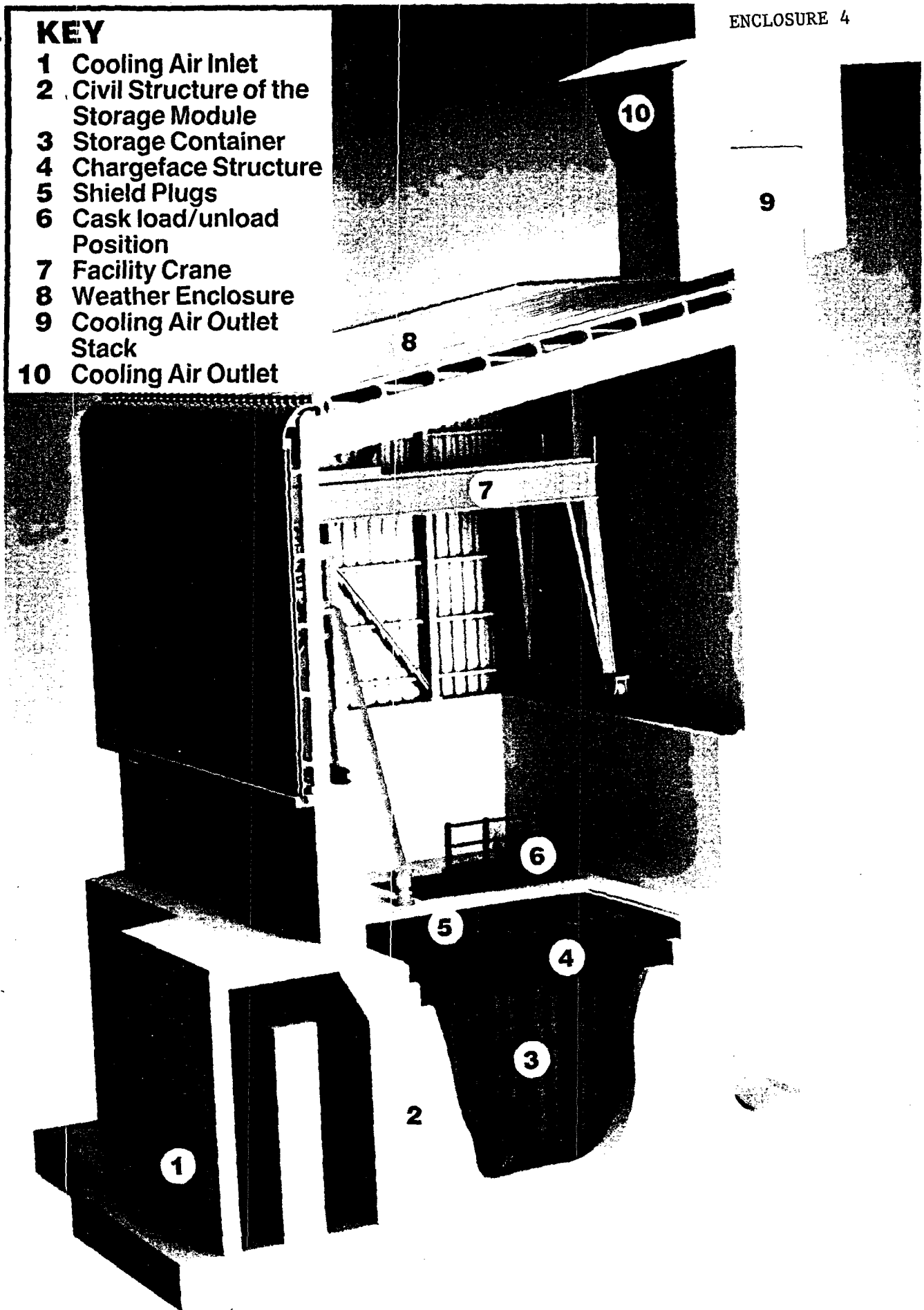

Photograph illustrating a single MVDS Vault Module. This model is representative of the six vault MVDS to be constructed by the Public



7  
6  
5  
4  
3  
2  
1



2 of 11

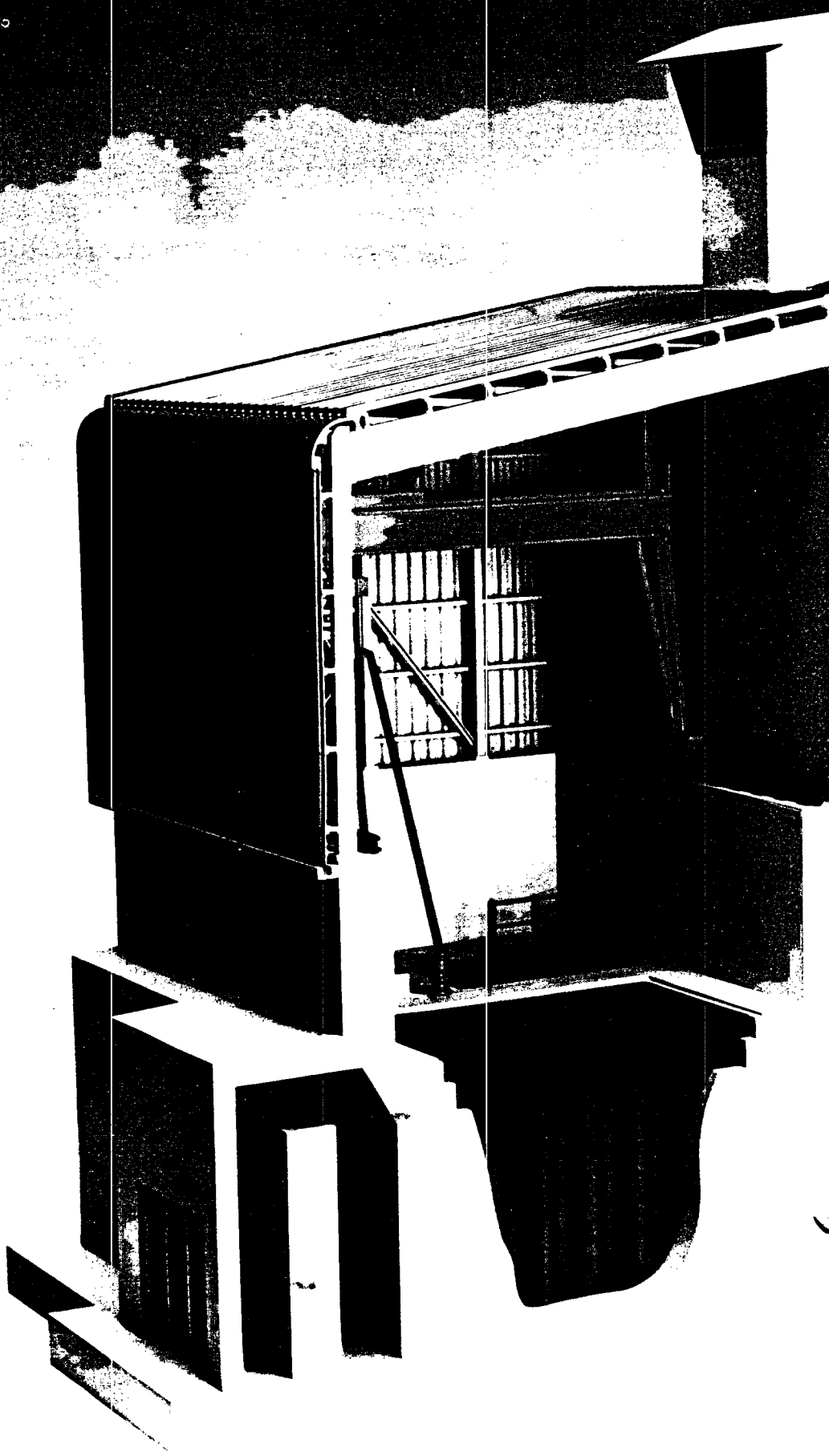



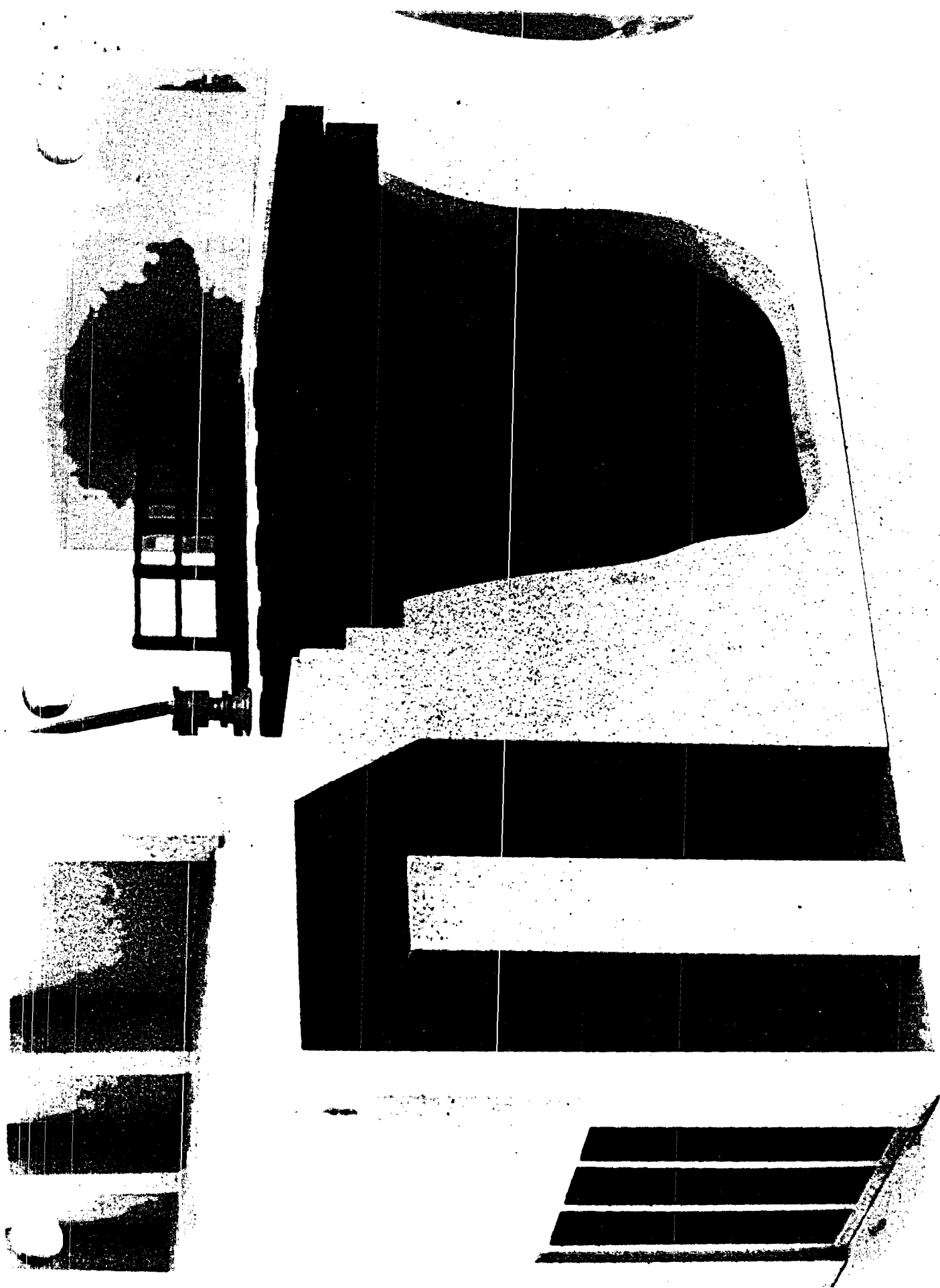

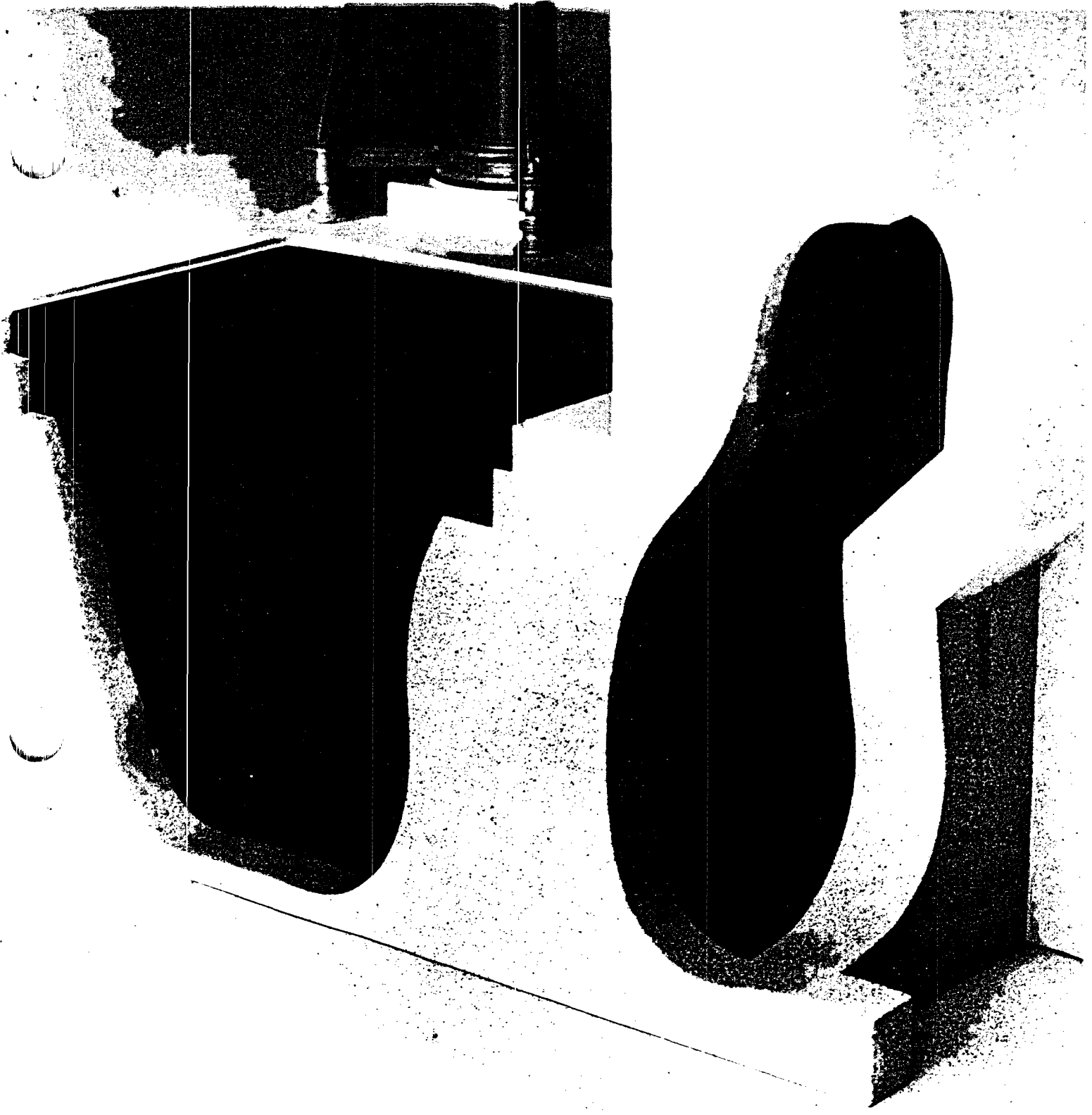

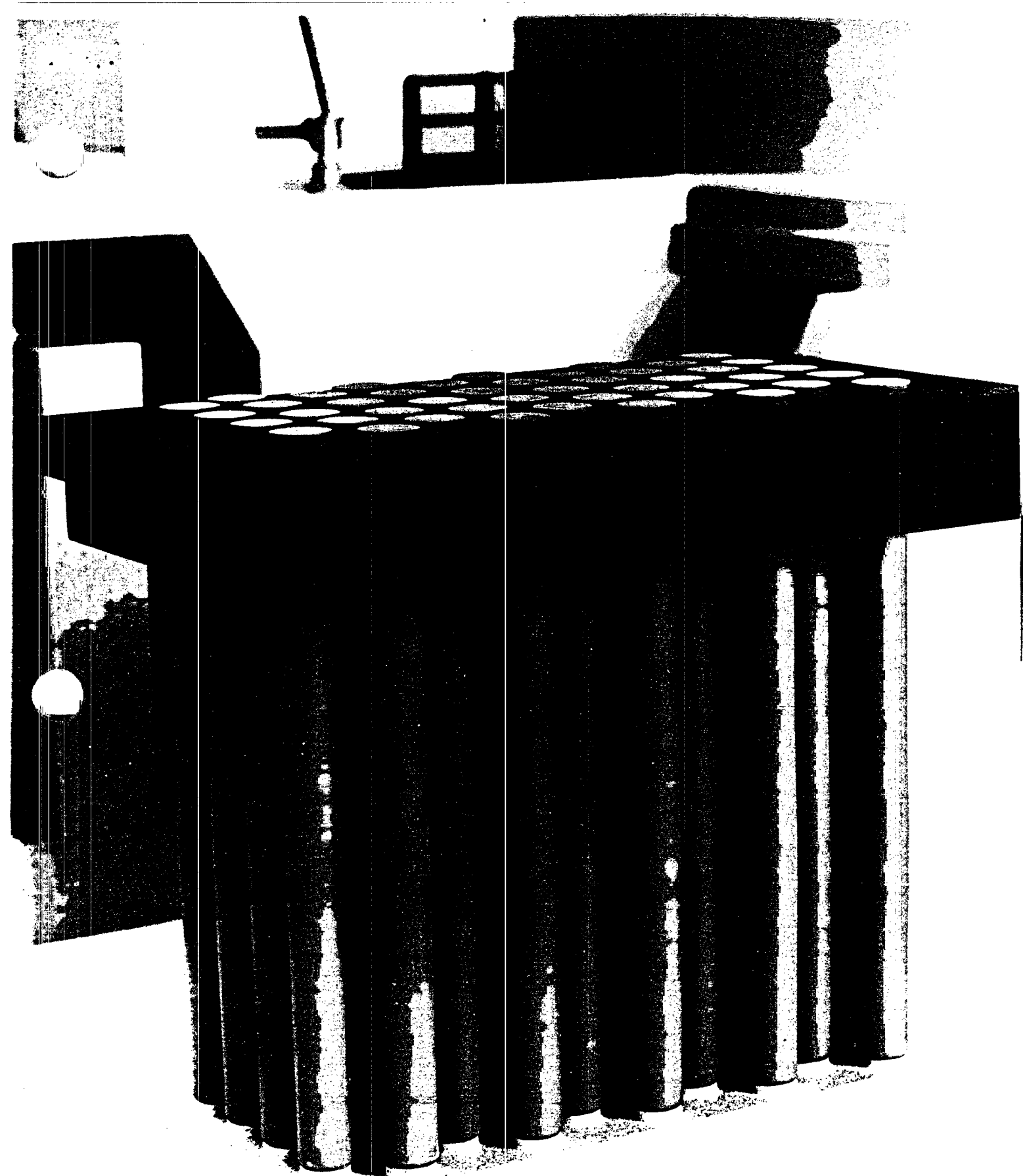

7811



