



Entergy Nuclear Operations, Inc.
Pilgrim Nuclear Power Station
600 Rocky Hill Road
Plymouth, MA 02360

September 13, 2007

Stephen J. Bethay
Director, Nuclear Assessment

U.S. Nuclear Regulatory Commission
ATTN: Document Control Desk
Washington, DC 20555-0001

SUBJECT: Entergy Nuclear Operations, Inc.
Pilgrim Nuclear Power Station
Docket No. 50-293, License No. DPR-35

Response to NRC Request for Additional Information Related to Third Ten-Year Pilgrim Relief Request, PRR-42, Examinations of Component Welds with Less Than Essentially 100% Examination Coverage

- REFERENCES
1. Entergy (BEC) Letter No. 2.95.091, ASME Section XI, Third Interval Inservice Inspection Plan, Pilgrim Nuclear Power Station, dated September 1, 1995
 2. Entergy Letter No. 2.06.054, Third Ten-Year ISI Interval Pilgrim Relief Request, PRR-42, Examinations of Component Welds with Less Than Essentially 100% Examination Coverage, dated June 28, 2006
 3. Entergy Letter No. 2.07.051, Third Ten-Year ISI Interval Pilgrim Relief Request, PRR-42, Examinations of Component Welds with Less Than Essentially 100% Examination Coverage, dated May 16, 2007
 4. ASME Section XI, Code Case N-460, "Alternative Examination Coverage for Class 1 and Class 2 Welds, Section XI, Division 1"

LETTER NO. 2.07.076

Dear Sir or Madam:

By Reference 1, Entergy submitted Pilgrim's Third Ten-Year Inservice Inspection Plan for the interval of July 1, 1995 to June 30, 2005, in accordance with the 1989 ASME Code, Section XI requirements pursuant to 10 CFR 50.55a.

During the Third Ten-Year Interval, Pilgrim completed the required in-service examinations in accordance with the plan; with the exceptions of certain components that could not fully meet the volumetric examination requirements stipulated in the 1989 ASME Code, Section XI, including the clarifications provided in the ASME Code Case N-460 (Ref. 4). Entergy has determined that conformance with the code requirement of essentially 100% coverage of weld volume or area examined was impractical due to various constraints and limitations. Accordingly, pursuant to 10 CFR 50.55a (g)(5)(iii), Entergy submits the attached Pilgrim Relief Request No, PRR-42 (Attachment 1), and Response to NRC Request for Additional Information, PRR-42 Rev. 1 (Attachment 2) for NRC review and approval.

A047
NRR

In March 2007, the NRC requested additional information to complete their review of PRR-42. Subsequently, NRC Staff and Entergy held a conference call to discuss the scope of the NRC request and Entergy informed the Staff that they would respond to the NRC request by September 15, 2007 (References 2 and 3).

PRR-42 proposes alternatives where the requirement of "essentially 100%" volumetric examination was not feasible due to construction limitations, obstructions, accessibility, and examination techniques. The alternatives and justifications are explained in the attached relief request which provides a list of components that requires relief from the "essentially 100%" volumetric examination requirements pursuant to 10 CFR 50.55a. The alternatives and justifications provide acceptable level of quality and safety and will not adversely impact the health and safety of the public.

There are no commitments contained in this letter.

A similar ISI Relief Request No. B-5 for Vermont Yankee Nuclear Power Station was approved by the NRC Letter dated September 19, 2005 (TAC. No. MC 0959).

If you have any questions on this transmittal, please contact me at 508-830-7800.

Sincerely,

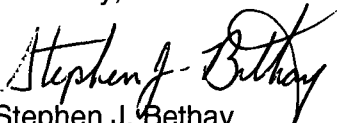

Stephen J. Bethay

SJB/wgl

Attachments: 1. Pilgrim Relief Request, PRR-42 and Program Data Sheets for Examinations with less than "Essentially 100% coverage (248 pages)
2. Response to NRC Request for Additional Information, PRR-42 Rev. 1 (52 pages)

cc: Mr. James Kim, Project Manager
Office of Nuclear Reactor Regulation
Mail Stop: 0-8C-2
U.S. Nuclear Regulatory Commission
1 White Flint North
11555 Rockville Pike
Rockville, MD 20852

U.S. Nuclear Regulatory Commission
Region 1
475 Allendale Road
King of Prussia, PA 19406

Senior Resident Inspector
Pilgrim Nuclear Power Station

PILGRIM RELIEF REQUEST PRR-42

Attachment 1 to Entergy Letter 2.07.076

**Entergy Nuclear Northeast
Pilgrim Nuclear Power Station
3rd 10-Year ISI Interval Closeout**

**Proposed Alternative
In Accordance with 10 CFR 50.55a(g)(5)(iii)**
(Inservice Inspection Impracticality - Alternative Provides Acceptable Level
of Quality and Safety)

1. ASME Code Component(s) Affected

Code Classes: 1, 2

References: Subarticle IWB-2500, Subarticle IWC-2500, GL 88-10, NUREG 0313,
ASME Code Case N-460

Examination Categories: B-A, B-D, B-F, B-H, B-J, B-O, C-C, C-F-1 and C-F-2

Item Numbers: B1.12, B1.21, B1.30, B3.90, B5.10, B5.130, B8.10, B9.11, B9.21,
B14.10, C3.20, C5.11, C5.51

Description: Volumetric and Surface Examination Coverage

Component Numbers: Various, see Table 3

2. Applicable Code Edition and Addenda

1989 Edition with no addenda

3. Applicable Code Requirements

Subarticle IWB-2500 states in part "Components shall be examined and tested as specified in Table IWB-2500-1". Table IWB-2500-1 requires a volumetric examination or a surface and volumetric examination be performed on the component based on Category and Item Number. The applicable examination area or volume and method required are as shown below from Table IWB-2500-1:

TABLE 1

Examination Category	Item Number	Examination Requirements /Figure Number	Examination Method
B-A	B1.12	IWB-2500-2	Volumetric
B-A	B1.21	IWB-2500-3	Volumetric
B-A	B1.30	IWB-2500-4	Volumetric
B-D	B3.90	IWB-2500-7	Volumetric
B-F	B5.10	IWB-2500-8	Volumetric and Surface
B-F	B5.130	IWB-2500-8	Volumetric and Surface
B-H	B8.10	IWB-2500-13	Surface
B-J	B9.11	IWB-2500-8	Volumetric and Surface
B-J	B9.21	IWB-2500-8	Surface
B-O	B14.10	IWB-2500-18	Volumetric or Surface

PILGRIM RELIEF REQUEST PRR-42

Subarticle IWC-2500 states in part, "Components shall be examined and pressure tested as specified in Table IWC-2500-1." Table IWC-2500-1 requires a surface examination or a surface and volumetric examination to be performed on the component based on Category and Item Number. The applicable examination area or volume and method required are as shown below from Table IWC-2500-1:

TABLE 2

Examination Category	Item Number	Examination Requirements / Figure Number	Examination Method
C-C	C3.20	IWC-2500-5	Surface
C-F-1	C5.11	IWC-2500-7	Surface & Volumetric
C-F-2	C5.51	IWC-2500-7	Surface & Volumetric

The Code requires that the entire volume or area be examined.

4. Impracticality of Compliance

Entire volume or area required is defined by ASME Section XI Code Case N-460 titled "Alternative Examination Coverage for Class 1 and Class 2 Welds, Section XI, Division 1". Code Case N-460 states in part, "...when the entire examination volume or area cannot be examined... a reduction in examination coverage... may be accepted provided the reduction in coverage for that weld is less than 10%".

The NRC through Information Notice 98-42 titled "Implementation of 10 CFR 50.55a(g) Inservice Inspection Requirements" termed the reduction in coverage of less than 10% to be "essentially 100 percent". Information Notice 98-42 states in part, "The NRC has adopted and further refined the definition of 'essentially 100 percent' to mean 'greater than 90 percent'... has been applied to all examinations of welds or other areas required by ASME Section XI."

Pilgrim's piping systems and associated components were designed and fabricated before the examination requirements of ASME Section XI were formalized and published. Since this plant was not specifically designed to meet the requirements of ASME Section XI, literal compliance is not feasible or practical within the limits of the current plant design.

Physical obstructions imposed by design, geometry and materials of construction are typical of vessel appurtenances, biological shield wall, insulation support rings, structural and component support members, adjacent component weldments in close proximity, unique component configurations (valves and pumps), and dissimilar metal weldments.

Therefore, examination of the entire volume or area for some of the components which are listed in Table 3 cannot be achieved. The specifics of the limitations and restrictions are also provided in Table 3. The Attachment 2 to this relief request provides the actual data sheets of examinations with less than essentially 100% coverage.

Accordingly, pursuant to 10 CFR 50.55a(g)(5)(iii), Entergy has determined that conformance with the code requirement of essentially 100% coverage of weld volume or area examined was impractical due to various constraints and limitations as stated above. Entergy requests NRC approval of the proposed alternative as stated below.

PILGRIM RELIEF REQUEST PRR-42

5. Burden Caused by Compliance

To increase the percentage coverage of the volume or area examined, the Reactor Pressure Vessel (RPV), Class 1 piping nozzles, portion of the Class 1 piping system, the CRD Housing, and a number of the Class 2 piping system support lugs would have to be re-designed, re-fabricated, or removed. These activities would also require extensive engineering and design effort, as well as the shutdown of the plant for modification installation. These activities are impractical for the plant to undertake.

6. Proposed Alternative and Basis for Use

- A). The components listed in Table 3 have already been examined by the available methods to the maximum extent practical. No additional volumetric or surface examinations will be performed on the components for the 3rd Inservice Inspection Interval.
- B). A visual inspection (VT-2) is performed by VT-2 qualified operators on the subject components during the system pressure tests (with no leakage detected) as required by code category B-P (each refueling outage) and category C-H (each period).

Basis for Use

As a minimum, all components received the required examination(s) to the extent practical with regard to the limited or lack of access available. The examinations conducted confirmed satisfactory results evidencing no unacceptable flaws present, even though "essentially 100%" coverage was not attained. PNPS has concluded that if any active degradation mechanisms were to exist in the subject welds, those degradations would have been identified in the examinations performed.

For surface examinations PNPS calculated the coverage percentage based on the area that was examined within the required coverage area divided by the required surface area to be inspected. For volumetric (ultrasonic) examinations there are many ways to calculate coverage. PNPS elected to use the following method. The required examination volume was calculated. The examination was performed in accordance with an approved ultrasonic procedure that met the governing Code requirements. The approved procedure requires a number of angles and a number of beam directions for each angle. For each angle/beam direction combination the volume interrogated by that beam was calculated (within the required coverage volume). Then that value was divided by the required examination volume to determine percentage coverage for each angle/beam-direction combination. Then those required angle/beam-direction coverage percentages were averaged to determine an overall composite coverage. For example, prior to invoking Appendix VIII, ASME Section V, Article 4 required 0°, 45°, and 60° search units for examining vessel welds from the OD of the vessel. The 45° and 60° search units are each required to be scanned in four orthogonal directions. Therefore, a total of nine angle/beam- directions are required and a coverage percentage is calculated for each of those nine angle/beam-direction combinations. Then those nine values are averaged to determine the overall composite coverage. (Note: Since Appendix VIII was invoked for vessel welds, the required number of angle/beam-direction combinations now depends on the qualified procedure, and thus the calculation would be different.)

For the most part, PNPS did not select alternative welds when coverage was limited on the scheduled weld. A sample plan implies a certain amount of random choice in the

PILGRIM RELIEF REQUEST PRR-42

selection of welds for examination — unless there are more conservative ways to select the sample, such as selecting high stress points or welds where industry experience indicates that damage mechanisms are more likely. This is why for Category C-F-2, terminal end welds are singled out; they are more typically high stressed. The reason for interferences is usually independent of the flaw mechanism. However, there may be cases where this is not true. For example, valve-to-pipe welds and pump-to-pipe weld geometries may inhibit coverage. But, these welds may actually have higher stresses because of their configurations. In these cases, if alternative welds were selected, the sample of higher stressed welds in the population would be diluted. If alternative welds are chosen, the selection randomness decreases. Flaw mechanisms associated with test limitations may be missed and it may be better to accept the limited coverage than to select alternative welds.

There is Code precedent for allowing limited coverage due to inaccessibility. ASME Section XI exempts certain Class 1 and Class 2 welds from examination based on the criteria that they are inaccessible. Paragraphs IWB-1220(c) and IWC-1230 exempt welds that are inaccessible due to control rod drive penetrations or because they are encased in concrete. The Code recognizes that examination of these welds is not possible, and therefore, a Relief Request would not be necessary. The same logic applies to portions of welds that are inaccessible and where examination of those portions of welds is not possible.

To summarize, PNPS has examined all components in the 3rd Interval ISI Program and associated augmented programs to the maximum extent possible given the inspection limitations discussed above. The portion of the PNPS ISI Program surface and volumetric inspection sample that could not be examined (expressed in inches of weld metal) due to limitations/interferences during the 3rd ten year interval is approximately 4% when compared to the total weld length that could have been examined if no limitations had been present.

When the PNPS ISI Program is viewed in total, the overall degree of coverage obtained is still greater than 90%, i.e. essentially 100%. For this and the other reasons detailed in this request, Entergy believes that the limited coverage obtained on the components listed in Table 3 is not significant and will provide an adequate level of quality and safety for examination of the affected welds, and will not adversely impact the health and safety of the public.

7. Duration of Proposed Alternative

Relief is requested for the third ten-year interval of the Inservice Inspection Program for Pilgrim, which began July 1, 1995 and concluded June 30, 2005.

8. Attachment

Pilgrim 3rd Interval ISI program datasheets for examinations with less than “Essentially 100%” coverage are attached (Table 3).

PILGRIM RELIEF REQUEST PRR-42

TABLE 3

COMPONENTS WITH LESS THAN "ESSENTIALLY 100%" COVERAGE						
CODE CATEGORY	CODE ITEM	COMPONENT ID	DESCRIPTION	COMBINED NDE COVERAGE		LIMITATION (CAUSE OF REDUCED COVERAGE)
				MT/PT	UT	
B-A	B1.21	RPV-BH-C1	HEAD CIRCUMF. WELD	---	75	VESSEL SKIRT CONFIGURATION AND THERMOCOUPLES
B-A	B1.12	RPV-L-1-338A	LOWER INTERMEDIATE SHELL VERTICAL WELD	---	89	JET PUMP RISER SUPPORT INTERFERENCE
B-A	B1.12	RPV-L-1-338C	LOWER INTERMEDIATE SHELL VERTICAL WELD	---	25	JET PUMP RISER SUPPORT, SURV. SPECIMEN HOLDER & SUPPORT BRACKETS, SHROUD REPAIR TIE ROD INTERFERENCE
B-A	B1.12	RPV-L-2-338A	LOWER SHELL VERTICAL WELD	---	73	BAFFLE PLATE AND BAFFLE GUSSET INTERFERENCE
B-A	B1.12	RPV-L-2-338B	LOWER SHELL VERTICAL WELD	---	78	BAFFLE PLATE GUSSET INTERFERENCE
B-A	B1.12	RPV-L-2-338C	LOWER SHELL VERTICAL WELD	---	25	BAFFLE PLATE, GUSSET, SHROUD REPAIR TIE ROD INTERFERENCE, N2K NOZZLE
B-A	B1.12	RPV-L-2-339A	UPPER INTERMEDIATE SHELL VERTICAL WELD	---	81	FW AND CS SPARGER INTERFERENCE
B-A	B1.12	RPV-L-2-339B	UPPER INTERMEDIATE SHELL VERTICAL WELD	---	75	FW AND CS SPARGER INTERFERENCE AND ID TAPER
B-A	B1.12	RPV-L-2-339C	UPPER INTERMEDIATE SHELL VERTICAL WELD	---	83	FW AND CS SPARGER INTERFERENCE
B-A	B1.30	RPV-SF-0-120	SHELL TO FLANGE	---	81	N3 NOZZLES, NOZZLE PLUGS, GUIDE RODS @ 0 & 180 deg, FLANGE CONFIGURATION

PILGRIM RELIEF REQUEST PRR-42

COMPONENTS WITH LESS THAN "ESSENTIALLY 100%" COVERAGE						
CODE CATEGORY	CODE ITEM	COMPONENT ID	DESCRIPTION	COMBINED NDE COVERAGE		LIMITATION (CAUSE OF REDUCED COVERAGE)
				MT/PT	UT	
B-A	B1.30	RPV-SF-120-240	SHELL TO FLANGE	---	81	N3 NOZZLES, NOZZLE PLUGS, GUIDE RODS @ 0 & 180 deg, FLANGE CONFIGURATION
B-A	B1.30	RPV-SF-240-360	SHELL TO FLANGE	---	81	N3 NOZZLES, NOZZLE PLUGS, GUIDE RODS @ 0 & 180 deg, FLANGE CONFIG.
B-D	B3.90	RPV-N7A-NV	NOZZLE TO VESSEL	---	56.7	NOZZLE CONFIGURATION
B-D	B3.90	RPV-N7B-NV	NOZZLE TO VESSEL	---	56.7	NOZZLE CONFIGURATION
B-D	B3.90	RPV-N8-NV	NOZZLE TO VESSEL	---	70.6	NOZZLE CONFIGURATION
B-F	R1.20 (B5.130)	14-A-10A	VALVE TO PIPE	---	37.1	PIPE TO VALVE WELD PROFILE
B-F	R1.20 (B5.130)	14-B-10A	VALVE TO PIPE	---	22.1	PIPE TO VALVE WELD PROFILE
B-F	R1.20 (B5.10)	2R-N1B-1	NOZZLE TO SAFE END	---	75	REDUCED COVERAGE ON CIRC. SCANS DUE TO SURFACE CONTOUR AND MIN. WALL ISSUES
B-F	R1.20 (B5.10)	2R-N2E-1	SAFE END TO NOZZLE	---	81.2	REDUCED COVERAGE ON CIRC. SCANS DUE TO SURFACE CONTOUR AND MIN. WALL ISSUES
B-F	R1.20 (B5.10)	2R-N2G-1	SAFE END TO NOZZLE	---	75.3	REDUCED COVERAGE ON CIRC. SCANS DUE TO SURFACE CONTOUR AND MIN. WALL ISSUES
B-F	R1.20 (B5.10)	2R-N2J-1	SAFE END TO NOZZLE	---	75	REDUCED COVERAGE ON CIRC. SCANS DUE TO SURFACE CONTOUR AND MIN. WALL ISSUES
B-F	R1.11 (B5.10)	6-N4A-1	SAFE END TO NOZZLE	---	87.5	REDUCED COVERAGE DUE TO WELDED THERMOCOUPLE PADS
B-F	R1.11 (B5.10)	6-N4B-1	SAFE END TO NOZZLE	---	87.5	REDUCED COVERAGE DUE TO WELDED THERMOCOUPLE PADS
B-F	R1.11 (B5.10)	6-N4C-1	SAFE END TO NOZZLE	---	88.6	REDUCED COVERAGE DUE TO WELDED THERMOCOUPLE PADS

PILGRIM RELIEF REQUEST PRR-42

COMPONENTS WITH LESS THAN "ESSENTIALLY 100%" COVERAGE						
CODE CATEGORY	CODE ITEM	COMPONENT ID	DESCRIPTION	COMBINED NDE COVERAGE		LIMITATION (CAUSE OF REDUCED COVERAGE)
				MT/PT	UT	
B-F	R1.11 (B5.10)	6-N4D-1	SAFE END TO NOZZLE	---	88.6	REDUCED COVERAGE DUE TO WELDED THERMOCOUPLE PADS
B-H	B8.10	RPV-SBW-0	RPV STABILIZER WELD	37	---	ONLY UPPER SURFACE ACCESSIBLE
B-J	R1.20 (B9.11)	10-IA-14	PIPE TO FLUED HEAD	---	50	PIPE TO PENETRATION FLUED HEAD CONFIGURATION
B-J	R1.20 (B9.11)	10-IA-15	PIPE TO VALVE	---	50	PIPE TO VALVE WELD PROFILE
B-J	R1.11 (B9.11)	10R-IA-6	PIPE TO VALVE	---	50	PIPE TO VALVE WELD PROFILE
B-J	R1.11 (B9.11)	10R-IA-7	VALVE TO PIPE	---	50	PIPE TO VALVE WELD PROFILE
B-J	R1.20 (B9.11)	12-O-24	PENETRATION TO PIPE	---	56.6	PENETRATION FLUED HEAD TO PIPE CONFIGURATION
B-J	R1.20 (B9.11)	14-A-19	PIPE TO VALVE	---	50	PIPE TO VALVE WELD PROFILE
B-J	R1.20 (B9.11)	14-B-17	PIPE TO PENETRATION	---	58.7	PIPE TO PENETRATION FLUED HEAD CONFIGURATION
B-J	R1.20 (B9.11)	14-B-20	PIPE TO PIPE	---	59.4	WALL OBSTRUCTION
B-J	R1.11 (B9.21)	1-SD-10R	PIPE TO VALVE	---	87.5	PIPE TO VALVE WELD PROFILE
B-J	R1.20 (B9.11)	2R-HB-1	HEADER TO BEND	---	75	REDUCER TO PIPE CONFIGURATION
B-J	R1.20 (B9.11)	2R-HB-4	HEADER TO BEND	---	75	REDUCER TO PIPE CONFIGURATION
B-O	B14.10	RPV-CRD-HSG-1	CRD HOUSING WELD	70	---	LIMITED EXAM DUE TO ADJACENT DRIVES; DRIVES CHOSEN TO MAXIMIZE COVERAGE; SHOOTOUT STEEL REMOVED FOR EXAM.
B-O	B14.10	RPV-CRD-HSG-2	CRD HOUSING WELD	50	---	LIMITED EXAM DUE TO ADJACENT DRIVES; DRIVES CHOSEN TO MAXIMIZE COVERAGE; SHOOTOUT STEEL REMOVED FOR EXAM.
B-O	B14.10	RPV-CRD-HSG-3	CRD HOUSING WELD	50	---	LIMITED EXAM DUE TO ADJACENT DRIVES; DRIVES CHOSEN TO

PILGRIM RELIEF REQUEST PRR-42

COMPONENTS WITH LESS THAN "ESSENTIALLY 100%" COVERAGE						
CODE CATEGORY	CODE ITEM	COMPONENT ID	DESCRIPTION	COMBINED NDE COVERAGE		LIMITATION (CAUSE OF REDUCED COVERAGE)
				MT/PT	UT	
						MAXIMIZE COVERAGE; SHOOTOUT STEEL REMOVED FOR EXAM.
B-O	B14.10	RPV-CRD-HSG-4	CRD HOUSING WELD	65	---	LIMITED EXAM DUE TO ADJACENT DRIVES; DRIVES CHOSEN TO MAXIMIZE COVERAGE; SHOOTOUT STEEL REMOVED FOR EXAM.
C-C	C3.20	EB-23-13HL1(4)	SUPPORT LUGS	87.5	---	HANGER CLAMP AGAINST 1 SIDE OF LUG
C-C	C3.20	EB-23-59HL1(4)	SUPPORT LUGS	83.3	---	HANGER CLAMP AGAINST 1 SIDE OF LUG
C-C	C3.20	HL-10-200HL1(4)	SUPPORT LUGS	90	---	HANGER CLAMP AGAINST 1 SIDE OF LUG
C-F-1	C5.11	GB-14-F34	PIPE TO VALVE	---	29.8	PIPE-TO VALVE WELD PROFILE
C-F-2	C5.51	GB-10-9-2E	WELDOLET	85	63.8	PIPE CLAMP OBSTRUCTION
C-F-2	C5.51	HE-26-F238	VALVE TO PIPE	---	68.8	ONE-SIDED EXAM DUE TO VALVE

**Pilgrim 3rd Interval ISI Program Data Sheets for
Examinations with less than
“Essentially 100% coverage
(240 pages)**

**(Third Ten-Year ISI Interval:
July 1, 1995 to June 30, 2005)**

APRIL 2006

Pages 1 of 240



GE ENERGY, NUCLEAR

EXAMINATION SUMMARY SHEET

Report No.:
PIL-R15-05-002

Site: Pilgrim Nuclear Power Station Component ID: RPV-BH-C1
 Outage: RF-015 HEAD CIRCUMF WELD
 System: RPV ASME Cat.: B-A ASME Item: B1.21 Aug Req: N/A

Exams Performed	Data Sheet	Cal Sheet	Procedure	Calibration Block	Examination Personnel	Cert Level	Date
60° Long.	UT-086	N/A	TP04-018 (GE-UT-300)	PIL-5E	Scott Erickson	II	4/28/2005
60° Long.	UT-087	N/A	TP04-018 (GE-UT-300)	CAL-IIW2-033	Scott Erickson	II	4/28/2005
60° Long.	UT-088	N/A	TP04-018 (GE-UT-300)	CAL-IIW2-017	Steve Snyder	II	4/28/2005
60° Long.	UT-089	N/A	TP04-018 (GE-UT-300)	PIL-5B	Steve Snyder	II	4/28/2005
45° Shear	UT-090	N/A	TP04-018 (GE-UT-300)	PIL-5B	Steve Snyder	II	4/28/2005
45° Shear	UT-091	N/A	TP04-018 (GE-UT-300)	PIL-5B	Steve Snyder	II	4/28/2005

Examination Results:

Ultrasonic examination results were acceptable to the requirements of ASME B&PV Code Section XI, 1989 Edition no Addenda, and Section XI, 1995 Edition with the 1996 Addenda as modified by the PDI program description and the Federal Register, Part II, Nuclear Regulatory Commission, 10 CFR Part 50 for Category B-A Reactor Pressure Vessel (RPV) Assembly Welds.

Manual transverse and parallel scans were performed in accordance with procedure GE-UT-300 V8 using 60° RL search units.

Scanning was restricted from one side of the weld due to the vessel skirt configuration and thermocouples.

Manual UT exams recorded (3) three indications, that were acceptable to the requirements of Section XI.

Coverage = 75%

Examination results were compared to data report 95-E-528,534,531 from 1995 outage with No Change

These examinations were performed under Work Order: N/A Change

This Summary and the following data sheets have been reviewed and accepted by the following personnel:

Prepared By: [Signature] Level: III Date: 4-30-05 Utility Review: [Signature] Date: 5-4-05
 ANII Review: [Signature] Date: 5/4/05

RWP: 0081
Dose: 110 mr.

Page 1 of 12



GE ENERGY, NUCLEAR

Ultrasonic Calibration and Examination Record RPV Components

Site/Unit: Pilgrim Nuclear Power Station / 1

Data Report Number: PIL-R15-05-002 Linearity Sheet: L-002

Outage: RF-015

Data Sheet Number: UT-008

Procedure: TP04-018 (GE-UT-300)

Rev.: R0 (Y0)

DRR: N/A

Calibration Block: PIL-5B

CS **Flt:** 4.35"
 Material Size Thickness
 Initial Cal: 1254 Exam Start 1330
 Cal Check: N/A Exam End 1540
 Cal Check: N/A Ultragel II 01225
 Final Cal: 1631 Couplant: Batch
242027 68° F 68° F
 Thermometer Initial Cal Temp. Final Cal Temp.

DAC Construction

Reflector	Hole Depth	Gain @ 1X	Max Amp	"W" Dim.	Sweep	Screen Div.
N/A	N/A	1X	N/A	N/A	N/A	N/A
N/A	N/A	1X	N/A	N/A	N/A	N/A
N/A	N/A	1X	N/A	N/A	N/A	N/A
ID	4.1"	1X	80%	7.2"	4.1"	7.2
N/A	N/A	1X	N/A	N/A	N/A	N/A

DAC 1X= 63.0 dB

Sweep 0-10 6" Depth

Note N/A dB difference between 3/8 and 5/8 Vee

Search Unit Data

Sigma 22BC-03006 211.1"x.62" VRect.
 Manufacturer: Serial Number: Size / Shape:
0.65" 60° 60°
 Incident Point: Nominal Angle: Measured Angle:
3.0 MHz SDCS Long
 Frequency: Model: Mode:

Search Unit Cable

RG-174 12' 0
 Cable Type: Length: Connectors:

Instrument Settings

Panametrics / Epoch 4 031526704
 Manufacturer/Model: Serial Number:
9.59 us 0.236 in./usec. 0.0 - 3.0 MHz
 Delay/Zero: Velocity: Narrowband Filter:
Auto **Fullwave** 12.0 in. **Sa / Mod**
 Rep Rate: Rectification: Range: Pulsar:
400 Ohms 0 3.03 MHz **Dual**
 Damping: Reject: Frequency: Mode:
Off **Off** **Off** **Off**
 DAC: TVG: CSC: DGS:

Exam Data for Weld: RPV-BH-C1

HEAD CIRCUMF WELD

Configuration:

00 72° F
 Exam Surface: Component Temperature

Weld Examination Area:	Exam Access	Scan dB	Recordable Indications	Exam Angle
<u>Plate</u>	<u>I</u>	<u>69.0</u>	<u>NFI</u>	<u>60°</u>
<u>Plate CW/CCW</u>	<u>E</u>	<u>69.0</u>	<u>NFI</u>	<u>60°</u>

Calibration Verification

Field Simulator Block S/N: N/A

Reflector	<u>N/A</u>	<u>N/A</u>	<u>N/A</u>
Amplitude	<u>N/A</u>	<u>N/A</u>	<u>N/A</u>
Gain (dB)	<u>N/A</u>	<u>N/A</u>	<u>N/A</u>
Sweep (SD)	<u>N/A</u>	<u>N/A</u>	<u>N/A</u>

Acceptable Linearity performed: 4/15/2005

Comments: Cal/Exam Date is the date of examination. See coverage sheet for limitations.

Calibration for full volume examination. Exams performed to maintain a 10 - 20% FSH clad roll.

Exam performed from meridinal weld RPV-BH-M1 to RPV-BH-M3 and from RPV-BH-M7 to RPV-BH-M1.

Single sided exam due to component configuration.

Exam limited from meridinal weld # M8 measuring "L" from 31.5" to 36.5" and a "W" of 5 - 6" due to a thermocoupler.

SRE Scott Erickson II 4/28/2005
 Initials: Examiner Level Cal/Exam Date:
N/A N/A
 Initials: Examiner Level Date:
BMD III 4-30-05
 GE Reviewed By: Level: Date:

[Signature] 5-4-05
 Utility Reviewed By: Date:
[Signature] 5/4/05
 ANII Reviewed By: Date:



GE ENERGY, NUCLEAR

Ultrasonic Calibration and Examination Record
RPV Components

Site/Unit: Pilgrim Nuclear Power Station / 1
Outage: RF-015

Data Report Number: PIL-R15-05-002 Linearity Sheet: L-002
Data Sheet Number: UT-087

Procedure: TP04-018 (GE-UT-300)

Rev.: R2 (V2)

DRR: N/A

Calibration Block: CAL-IIW2-033

<u>CS</u>	<u>N/A</u>	<u>4.0"</u>
Material	Size	Thickness
Initial Cal: <u>1258</u>		Exam Star: <u>1330</u>
Cal Check: <u>N/A</u>		Exam End: <u>1540</u>
Cal Check: <u>N/A</u>	<u>Ultracal II</u>	<u>01225</u>
Final Cal: <u>1624</u>	Couplant:	Batch:
<u>242027</u>	<u>68° F</u>	<u>68° F</u>
Thermometer	Initial Cal Temp.	Final Cal Temp:

Search Unit Data

<u>Sigma</u>	<u>22BC-03006</u>	<u>2(1.1"x.62")/Rect.</u>
Manufacturer:	Serial Number:	Size / Shape:
<u>0.65°</u>	<u>60°</u>	<u>60°</u>
Incident Point:	Nominal Angle:	Measured Angle:
<u>3.0 Mhz</u>	<u>SDC3</u>	<u>Long</u>
Frequency:	Model:	Mode:

Search Unit Cable

<u>RG-174</u>	<u>12'</u>	<u>0</u>
Cable Type:	Length:	Connectors:

Instrument Settings

<u>Panometrics / Epoch 4</u>	<u>031526704</u>		
Manufacturer/Model:	Serial Number:		
<u>9.59 us</u>	<u>0.238 in./us/c.</u>	<u>0.8 - 3.0 Mhz</u>	
Delay/Zero:	Velocity:	Narrowband Filter:	
<u>Auto</u>	<u>Fullwave</u>	<u>4.0 in.</u>	<u>So / Med</u>
Rep Rate:	Rectification:	Range:	Pulse:
<u>400 Ohms</u>	<u>0</u>	<u>3.09 Mhz</u>	<u>Dual</u>
Damping:	Reject:	Frequency:	Mode:
<u>Off</u>	<u>Off</u>	<u>Off</u>	<u>Off</u>
DAC:	TVG:	CSC:	DGS:

DAC Construction

Reflector	Hole Depth	Gain @ 1X	Max Amp	"W" Dim.	Sweep	Screen Div.
1/4	0.8"	1X	80%	1.15"	582"	3.0
N/A	N/A	1X	N/A	N/A	N/A	N/A
N/A	N/A	1X	N/A	N/A	N/A	N/A
N/A	N/A	1X	N/A	N/A	N/A	N/A
N/A	N/A	1X	N/A	N/A	N/A	N/A

DAC 1X= 60.8 dB
Sweep 0-10 2.0" Depth
Note N/A dB difference between 3/8 and 5/8 Vee

Exam Data for Weld: RPV-BH-C1
HEAD CIRCUMF WELD
Configuration:

<u>OR</u>	<u>12° F</u>			
Exam Surface:	Component Temperature			
Weld Examination Area:	Exam Access	Scan dB	Recordable Indications	Exam Angle
<u>Plate</u>	<u>I</u>	<u>74.8</u>	<u>NFI</u>	<u>60°</u>
<u>Plate CW/CCW</u>	<u>P</u>	<u>74.8</u>	<u>NFI</u>	<u>60°</u>

Calibration Verification

Field Simulator Block S/N: N/A

Reflector	Amplitude	Gain (dB)	Sweep (SD)
<u>N/A</u>	<u>N/A</u>	<u>N/A</u>	<u>N/A</u>
<u>N/A</u>	<u>N/A</u>	<u>N/A</u>	<u>N/A</u>
<u>N/A</u>	<u>N/A</u>	<u>N/A</u>	<u>N/A</u>

Acceptable Linearity performed : 4/15/2005

Comments: Cal/Exam Date is the date of examination. See coverage sheet for limitations.
Calibration for near surface examination. Exams performed a minimum of 14 dB above reference.
Exam performed from meridinal weld RPV-BH-M1 to RPV-BH-M3 and from RPV-BH-M7 thru RPV-BH-M1.
Single sided exam due to component configuration.

SE Scott Erickson II 4/28/2005
Initials: Examiner Level Cal/Exam Date:

N/A N/A
Initials: Examiner Level
BMO III 4-30-05
GE Reviewed By: Level: Date:

W.L. IV 5-4-05
Utility Reviewed By: Date:

Carl Hoffman 5/4/05
ANII Reviewed By: Date:



GE ENERGY, NUCLEAR

Ultrasonic Calibration and Examination Record RPV Components

Site/Unit: Pilgrim Nuclear Power Station / 1

Data Report Number: PIL-R15-05-002 Linearity Sheet: L-004

Outage: RF-015

Data Sheet Number: UT-088

Procedure: TP04-018 (GE-UT-300)

Rev.: R0 (V8)

DRR: N/A

Calibration Block: CAL-IIW2-01Z

CS	N/A	4.0"
Material	Size	Thickness
Initial Cal: <u>1305</u>		Exam Start: <u>1330</u>
Cal Check: <u>N/A</u>		Exam End: <u>1540</u>
Cal Check: <u>N/A</u>	<u>Ultracel II</u>	<u>01225</u>
Final Cal: <u>1643</u>	Couplant:	Batch
<u>242027</u>	<u>68° F</u>	<u>68° F</u>
Thermometer	Initial Cal Temp.	Final Cal Temp:

Search Unit Data

Sigma 22BC-03003 2(1.1"x.62")/Rect.
 Manufacturer: Serial Number: Size / Shape:
0.65" 60° 60°
 Incident Point: Nominal Angle: Measured Angle:
3.0 MHz SDC-3 Long
 Frequency: Model: Mode:

Search Unit Cable

RG-174 12' 2
 Cable Type: Length: Connectors:

Instrument Settings

Panometrics / Epoch 4 031574111
 Manufacturer/Model: Serial Number:
9.33 us 0.233 in./usec. 0.8 - 3.0 MHz
 Delay/Zero: Velocity: Narrowband Filter:
Auto Fullwave 4.0 in. So / Med
 Rep Rate: Rectification: Range: Pulsar:
400 Ohms 0 3.03 MHz Dual
 Damping: Reject: Frequency: Mode:
Off Off Off Off
 DAC: TVG: CSC: DGS:

DAC Construction

Reflector	Hole Depth	Gain @ 1X	Max. Amp	"W" Dim.	Sweep	Screen Div.
1/4	0.6"	1X	80%	1.6"	.61"	3.0
N/A	N/A	1X	N/A	N/A	N/A	N/A
N/A	N/A	1X	N/A	N/A	N/A	N/A
N/A	N/A	1X	N/A	N/A	N/A	N/A
N/A	N/A	1X	N/A	N/A	N/A	N/A

DAC 1X= 58.0 dB
 Sweep 0-10 4.0" Depth
 Note N/A dB difference between 3/8 and 5/8 Vee

Exam Data for Weld: RPV-BH-C1

HEAD CIRCUMF WELD

Configuration:

QQ 72° F
 Exam Surface: Component Temperature

Weld Examination Area:	Exam Access	Scan dB	Recordable Indications	Exam Angle
<u>Plate</u>	<u>I</u>	<u>72.0</u>	<u>NRI</u>	<u>60°</u>
<u>Plate CW/CCW</u>	<u>P</u>	<u>72.0</u>	<u>NRI</u>	<u>60°</u>

Calibration Verification

Field Simulator Block S/N: N/A

Reflector	<u>N/A</u>	<u>N/A</u>	<u>N/A</u>
Amplitude	<u>N/A</u>	<u>N/A</u>	<u>N/A</u>
Gain (dB)	<u>N/A</u>	<u>N/A</u>	<u>N/A</u>
Sweep (SD)	<u>N/A</u>	<u>N/A</u>	<u>N/A</u>

Acceptable Linearity performed: 4/15/2005

Comments: Cal/Exam Date is the date of examination. See coverage sheet for limitations.
 Calibration for near surface examination. Exams performed to maintain a 14 dB above reference.
 Exam performed from meridional weld RPV-BH-M3 thru RPV-BH-M7.
 Single sided exam due to component configuration.

ES Steve Snyder II 4/28/2005
 Initials: Examiner Level Cal/Exam Date:
N/A N/A
 Initials: Examiner Level
BMM III 4-30-05
 GE Reviewed By: Level: Date:

HT LVI III 5-4-05
 Utility Reviewed By: Date:
Carl Johnson 4/4/05
 ANII Reviewed By: Date:



GE ENERGY, NUCLEAR

Ultrasonic Calibration and Examination Record RPV Components

Site/Unit: Pilgrim Nuclear Power Station / 1
Outage: RF-015

Data Report Number: PIL-R15-05-002 Linearity Sheet: L-004
Data Sheet Number: UT-089

Procedure: TP04-018 (GE-UT-300)

Rev.: R0 (V8) DRR: N/A

Calibration Block: PIL-5B

CS Flt: 4.35"
Material Size Thickness

Initial Cal: 1307 Exam Start 1330
Cal Check: N/A Exam End 1540

Cal Check: N/A Ultragel II 01225
Final Cal: 1642 Couplant: Batch

242027 68° F 68° F
Thermometer Initial Cal Temp. Final Cal Temp.

DAC Construction

Reflector	Hole Depth	Gain @ 1X	Max Amp	"W" Dim.	Sweep	Screen Div.
N/A	N/A	1X	N/A	N/A	N/A	N/A
N/A	N/A	1X	N/A	N/A	N/A	N/A
N/A	N/A	1X	N/A	N/A	N/A	N/A
ID	<u>4.1"</u>	1X	<u>80%</u>	<u>7.5"</u>	<u>4.35"</u>	<u>7.3</u>
N/A	N/A	1X	N/A	N/A	N/A	N/A

DAC 1X= 60.5 dB
Sweep 0-10 6" Depth
Note N/A dB difference between 3/8 and 5/8 Vee

Exam Data for Weld: RPV-BH-C1
HEAD CIRCUMF WELD
Configuration:

OD 72° F
Exam Surface: Component Temperature

Weld Examination Area:	Exam Access	Scan dB	Recordable Indications	Exam Angle
<u>Plate</u>	<u>I</u>	<u>68.0</u>	<u>Yes</u>	<u>60°</u>
<u>Plate CW/CCW</u>	<u>P</u>	<u>68.0</u>	<u>NRI</u>	<u>60°</u>

Search Unit Data

Sigma 22BC-03003 2(1.1"x.62"V)Rect.
Manufacturer: Serial Number: Size / Shape:

0.65" 60° 60°
Incident Point: Nominal Angle: Measured Angle:

3.0 MHz SDC-3 Long
Frequency: Model: Mode:

Search Unit Cable

RG-174 12' 0
Cable Type: Length: Connectors:

Instrument Settings

Panemetrics / Epoch 4 031574111
Manufacturer/Model: Serial Number:

9.33 us 0.233 in./usec. 0.8 - 3.0 MHz
Delay/Zero: Velocity: Narrowband Filter:

Auto Fullwave 12.0 in. So. / Mod
Rep Rate: Rectification: Range: Pulsar:

400 Ohms 0 3.03 MHz Dual
Damping: Reject: Frequency: Mode:

Off: Off: Off: Off:
DAC: TVG: CSC: DGS:

Calibration Verification

Field Simulator Block S/N: N/A

Reflector	Amplitude	Gain (dB)	Sweep (SD)
<u>N/A</u>	<u>N/A</u>	<u>N/A</u>	<u>N/A</u>
<u>N/A</u>	<u>N/A</u>	<u>N/A</u>	<u>N/A</u>
<u>N/A</u>	<u>N/A</u>	<u>N/A</u>	<u>N/A</u>

Acceptable Linearity performed: 4/15/2005

Comments: Cal/Exam Date is the date of examination. See coverage sheet for limitations.
Calibration for full volume examination. Exams performed to maintain a 10 - 20% FSH clad roll.
Exam performed from meridional weld RPV-BH-M3 thru RPV-BH-M7
Single sided exam due to component configuration.
Exam limited at two places for an "L" of 5" and a "W" of 5 to 6" from weld centerline of M5 weld cw from 55" to 60" and M3 weld from 9" to 14".

SS Steve Snyder I 4/28/2005
Initials: Examiner Level Cal/Exam Date:

UT L1 III 5-4-05
Utility Reviewed By: Date:

N/A N/A
Initials: Examiner Level

Ant Harmon 5/4/05
ANIL Reviewed By: Date:

B/M III 4-30-05
GE Reviewed By: Level: Date:



GE ENERGY, NUCLEAR

Ultrasonic Calibration and Examination Record RPV Components

Site/Unit: Pilgrim Nuclear Power Station / 1
Outage: RF-015

Data Report Number: PIL-R15-05-002 Linearity Sheet: L-002
Data Sheet Number: UT-020

Procedure: TP04-018 (GE-UT-300)

Rev.: R0.0V8

DRR: N/A

Calibration Block: PIL-5B

<u>CS</u> Material	<u>Flat</u> Size	<u>4.35"</u> Thickness
Initial Cal: <u>1303</u>	Exam Star: <u>1330</u>	
Cal Check: <u>N/A</u>	Exam End: <u>1540</u>	
Cal Check: <u>N/A</u>	<u>Ultracel II</u> Couplant:	<u>01225</u> Batch
Final Cal: <u>1646</u>	<u>242027</u> Thermometer	<u>68° F</u> Initial Cal Temp.
		<u>68° F</u> Final Cal Temp.

Search Unit Data

KBA 010HX1 0.5"x1.0"/Recl
Manufacturer: Serial Number: Size / Shape:

0.65" 45° 45°
Incident Point: Nominal Angle: Measured Angle:

1.0 MHz 113-891-600 Shear
Frequency: Model: Mode:

Search Unit Cable

RG-174 12' 0
Cable Type: Length: Connectors:

Instrument Settings

Panametrix / Epoch 4 031526704
Manufacturer/Model: Serial Number:

13.91 us 0.1278 in./usec. 0.8 - 3.0 MHz
Delay/Zero: Velocity: Narrowband Filter:

Auto Fullwave 10.0 in. So / Med
Rep Rate: Rectification: Range: Pulsar:

400 Ohms 0 1.0 MHz P/E
Damping: Reject: Frequency: Mode:

Off Off Off Off
DAC: TVG: CSC: DGS:

DAC Construction

Reflector	Hole Depth	Gain @ 1X	Max Amp	"W" Dim.	Sweep	Screen Div.
1/4	1.1"	1X	80%	1.1"	1.1"	1.5
1/2	2.2"	1X	55%	2.2"	2.2"	3.0
3/4	3.3"	1X	34%	3.3"	3.3"	4.5
N/A	N/A	1X	N/A	N/A	N/A	N/A
N/A	N/A	1X	N/A	N/A	N/A	N/A

DAC 1X= 18.9 dB
Sweep 0-10 Z" Depth
Note N/A dB difference between 3/8 and 5/8 Vee

Exam Data for Weld: RPV-BH-C1
HEAD CIRCUMF WELD
Configuration:

00 72° F
Exam Surface: Component Temperature

Weld Examination Area:	Exam Access	Scan dB	Recordable Indications	Exam Angle
<u>Plate</u>	<u>UPST</u>	<u>32.0</u>	<u>NFI</u>	<u>45°</u>

Calibration Verification

Field Simulator Block S/N: N/A

Reflector	Amplitude	Gain (dB)	Sweep (SD)
<u>N/A</u>	<u>N/A</u>	<u>N/A</u>	<u>N/A</u>
<u>N/A</u>	<u>N/A</u>	<u>N/A</u>	<u>N/A</u>
<u>N/A</u>	<u>N/A</u>	<u>N/A</u>	<u>N/A</u>

Acceptable Linearity performed : 4/15/2005

Comments: Cal/Exam Date is the date of examination. See coverage sheet for limitations.
Calibration for indication verification. Exams performed a minimum of 14 dB above reference.

SS Steve Snyder II 4/28/2005
Initials: Examiner Level Cal/Exam Date:

[Signature] IT Lvl. III 5-11-05
Utility Reviewed By: Date:

N/A N/A
Initials: Examiner Level
B/M III 4-30-05
GE Reviewed By: Level: Date:

[Signature] 5/4/05
ANII Reviewed By: Date:



GE ENERGY, NUCLEAR

Ultrasonic Calibration and Examination Record RPV Components

Site/Unit: Pilgrim Nuclear Power Station / 1

Data Report Number: PIL-R15-05-002 Linearity Sheet: L-002

Outage: RF-015

Data Sheet Number: UT-091

Procedure: TP04-018 (GE-UT-300)

Rev.: R0 (V2)

DRR: N/A

Calibration Block: PIL-5B

<u>CS</u>	<u>Flt</u>	<u>4.35"</u>
Material	Size	Thickness
Initial Cal: <u>1301</u>		Exam Start: <u>1330</u>
Cal Check: <u>N/A</u>		Exam End: <u>1540</u>
Cal Check: <u>N/A</u>	<u>Ultras II</u>	<u>01225</u>
Final Cal: <u>1644</u>	Couplant:	Batch
<u>242027</u>	<u>68° F</u>	<u>68° F</u>
Thermometer	Initial Cal Temp.	Final Cal Temp:

Search Unit Data

<u>KBA</u>	<u>E02110</u>	<u>0.5"x1.0"/Rect</u>
Manufacturer:	Serial Number:	Size / Shape:
<u>0.65"</u>	<u>45°</u>	<u>45°</u>
Incident Point:	Nominal Angle:	Measured Angle:
<u>2.25 MHz</u>	<u>113-292-600</u>	<u>Shear</u>
Frequency:	Model:	Mode:

Search Unit Cable

<u>RG-174</u>	<u>12'</u>	<u>0</u>
Cable Type:	Length:	Connectors:

Instrument Settings

<u>Panametrics / Epoch 4</u>	<u>031526704</u>		
Manufacturer/Model:	Serial Number:		
<u>11.94 us</u>	<u>0.126 in./usec</u>	<u>0.8 - 3.0 MHz</u>	
Delay/Zero:	Velocity:	Narrowband Filter:	
<u>Auto</u>	<u>Fullwave</u>	<u>10.0 in.</u>	<u>Sq. / Med</u>
Rep Rate:	Rectification:	Range:	Pulser:
<u>400 Ohms</u>	<u>0</u>	<u>2.0 MHz</u>	<u>P/E</u>
Damping:	Reject:	Frequency:	Mode:
<u>Off</u>	<u>Off</u>	<u>Off</u>	<u>Off</u>
DAC:	TVG:	CSC:	DGS:

DAC Construction

Reflector	Hole Depth	Gain @ 1X	Max Amp	"W" Dim.	Sweep	Screen Div.
1/4	1.1"	1X	80%	1.1"	1.1"	1.5
1/2	2.2"	1X	50%	2.2"	2.2"	3.0
3/4	3.3"	1X	30%	3.3"	3.3"	4.5
N/A	N/A	1X	N/A	N/A	N/A	N/A
N/A	N/A	1X	N/A	N/A	N/A	N/A

DAC 1X= 16.9 dB

Sweep 0-10 Z Depth

Note N/A dB difference between 3/8 and 5/8 Vee

Exam Data for Weld: RPV-BH-C1

HEAD CIRCUMF WELD

Configuration:

<u>OD</u>	<u>72° F</u>
Exam Surface:	Component Temperature

Weld Examination Area:	Exam Access	Scan dB	Recordable Indications	Exam Angle
<u>Plate</u>	<u>UPST</u>	<u>30.9</u>	<u>Yes</u>	<u>45°</u>

Calibration Verification

Field Simulator Block S/N: N/A

Reflector	<u>N/A</u>	<u>N/A</u>	<u>N/A</u>
Amplitude	<u>N/A</u>	<u>N/A</u>	<u>N/A</u>
Gain (dB)	<u>N/A</u>	<u>N/A</u>	<u>N/A</u>
Sweep (SD)	<u>N/A</u>	<u>N/A</u>	<u>N/A</u>

Acceptable Linearity performed: 4/15/2005

Comments: Cal/Exam Date is the date of examination. See coverage sheet for limitations.

Calibration for indication verification. Exams performed a minimum of 14 dB above reference.

For recordable indication see RPV exam data sheet.

SS Steve Snyder II 4/28/2005
 Initials: Examiner Level Cal/Exam Date:

N/A N/A
 Initials: Examiner Level
BLM TLC 4-30-05
 GE Reviewed By: Level: Date:

UT L. III 5-4-05
 Utility Reviewed By: Date:
Chris Johnson 5/4/05
 ANII Reviewed By: Date:

Pilgrim Weld RPV-BH-C1

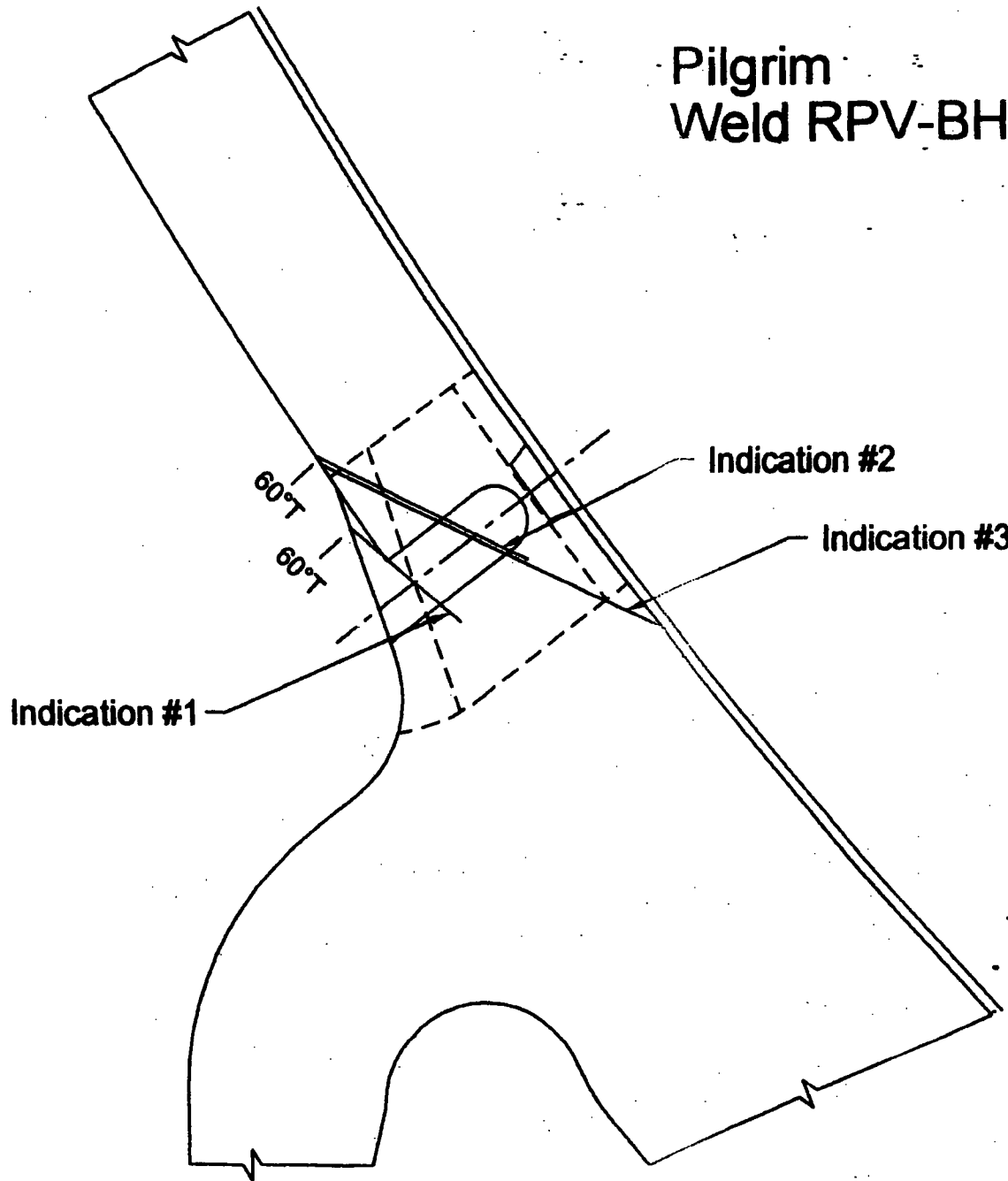

Pilgrim RF015, 2005

Handwritten signature
WT 2.1 III 5-2-05

Pilgrim - RFO15
 Weld RPV-BH-C1 Bottom Head Circumference
 Spring 2005

Weld Length = 593.8 Exam Volume = 24.5		CODE CROSS-SECTIONAL AREA		TOTAL CODE COVERAGE		
		Required Exam Area Sq. In.	Area Scanned Manual	Percent of Area Manual	Weld Length Manual	Percent Manual
60° NS T-Scan	A	5.3	3.9	15.9%	578.8	7.8%
60° S6 T-Scan	A	16.2	16.1	65.7%	578.8	32.0%
60° S4 T-Scan	A	3.0	3.0	12.2%	578.8	3.0%
60° NS P-Scan	A	5.3	3.2	13.1%	578.8	6.4%
60° S6 P-Scan	A	16.2	9.9	40.4%	578.8	19.7%
60° S4 P-Scan	A	3.0	2.0	8.2%	578.8	4.0%
60° NS T-Scan	B	5.3	3.9	15.9%	15	0.2%
60° S6 T-Scan	B	16.2	14.4	58.8%	15	0.7%
60° S4 T-Scan	B	3.0	2.5	10.2%	15	0.1%
60° NS P-Scan	B	5.3	3.2	13.1%	15	0.2%
60° S6 P-Scan	B	16.2	9.9	40.4%	15	0.5%
60° S4 P-Scan	B	3.0	2.0	8.2%	15	0.1%

% Total Composite Coverage = 75%

Comments: A - T-Scan and P-Scan restricted due to proximity of vessel skirt.
 B - T-Scan and P-Scan restricted due to proximity of vessel skirt and thermocouples.

Note - Rounding methods may affect calculated values.

13K 0761 III 5-4-05

Page 10/240

Pilgrim Weld RPV-BH-C1

60° NS Exam Volume = 5.3 Sq. In.
60° FV Exam Volume = 16.2 Sq. In.
60° Inner 15% Exam Volume = 3.0 Sq. In.

60° NS T-Scan achieved = 3.9 Sq. In.
60° FV T-Scan achieved = 14.4 Sq. In.
60° Inner 15% T-Scan achieved = 2.5 Sq. In.

60° P-Scan achieved = 3.2 Sq. In.
60° FV P-Scan achieved = 9.9 Sq. In.
60° Inner 15% P-Scan achieved = 2.0 Sq. In.

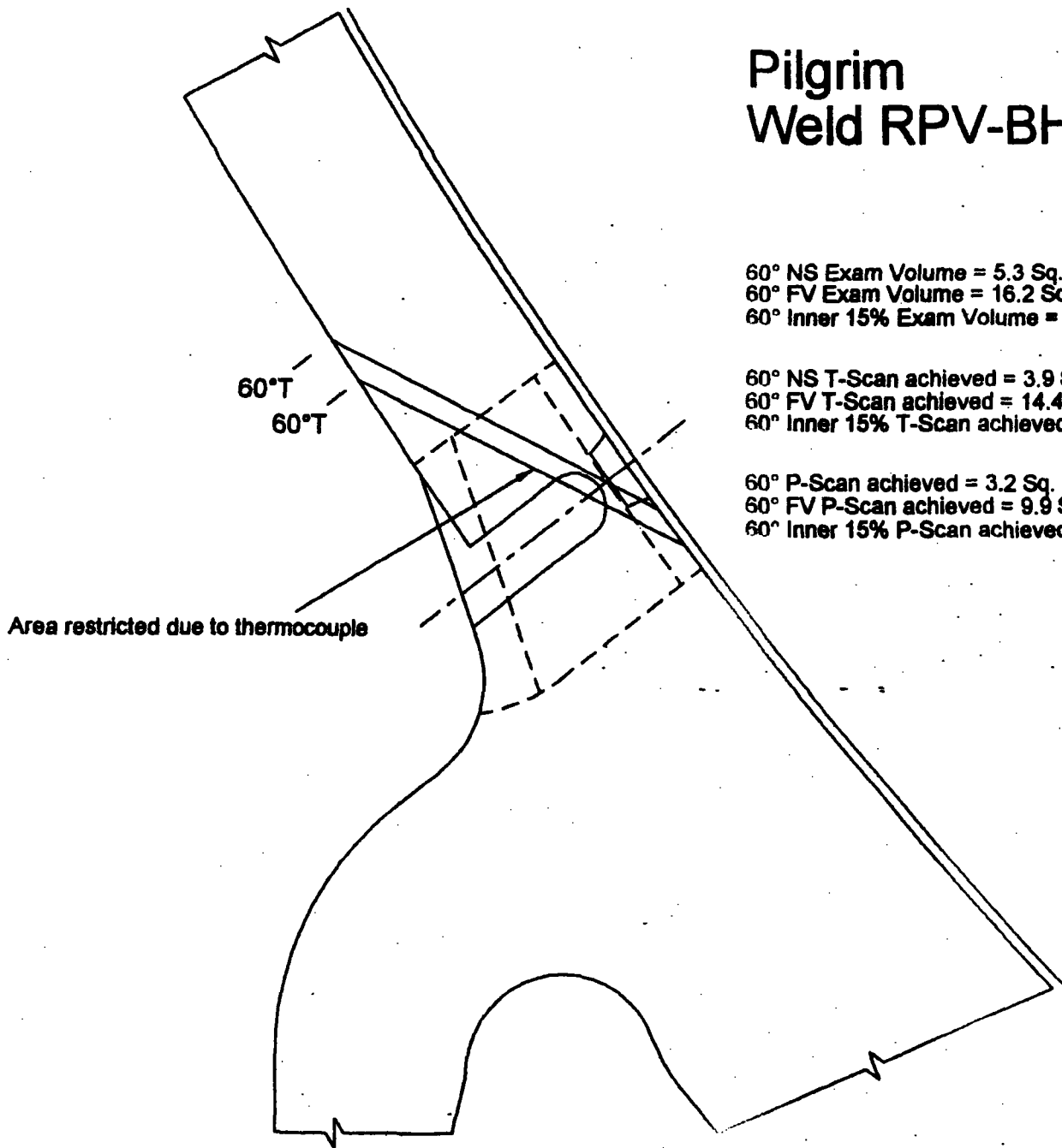

Pilgrim RF015, 2005

Handwritten signature
UT Lvl. III
5-4-05

Page 11 of 12

Page 11/240

Pilgrim Weld RPV-BH-C1

60° NS Exam Volume = 5.3 Sq. In.
60° FV Exam Volume = 16.2 Sq. In.
60° Inner 15% Exam Volume = 3.0 Sq. In.

60° NS T-Scan achieved = 3.9 Sq. In.
60° FV T-Scan achieved = 16.1 Sq. In.
60° Inner 15% T-Scan achieved = 3.0 Sq. In.

60° P-Scan achieved = 3.2 Sq. In.
60° FV P-Scan achieved = 9.9 Sq. In.
60° Inner 15% P-Scan achieved = 2.0 Sq. In.

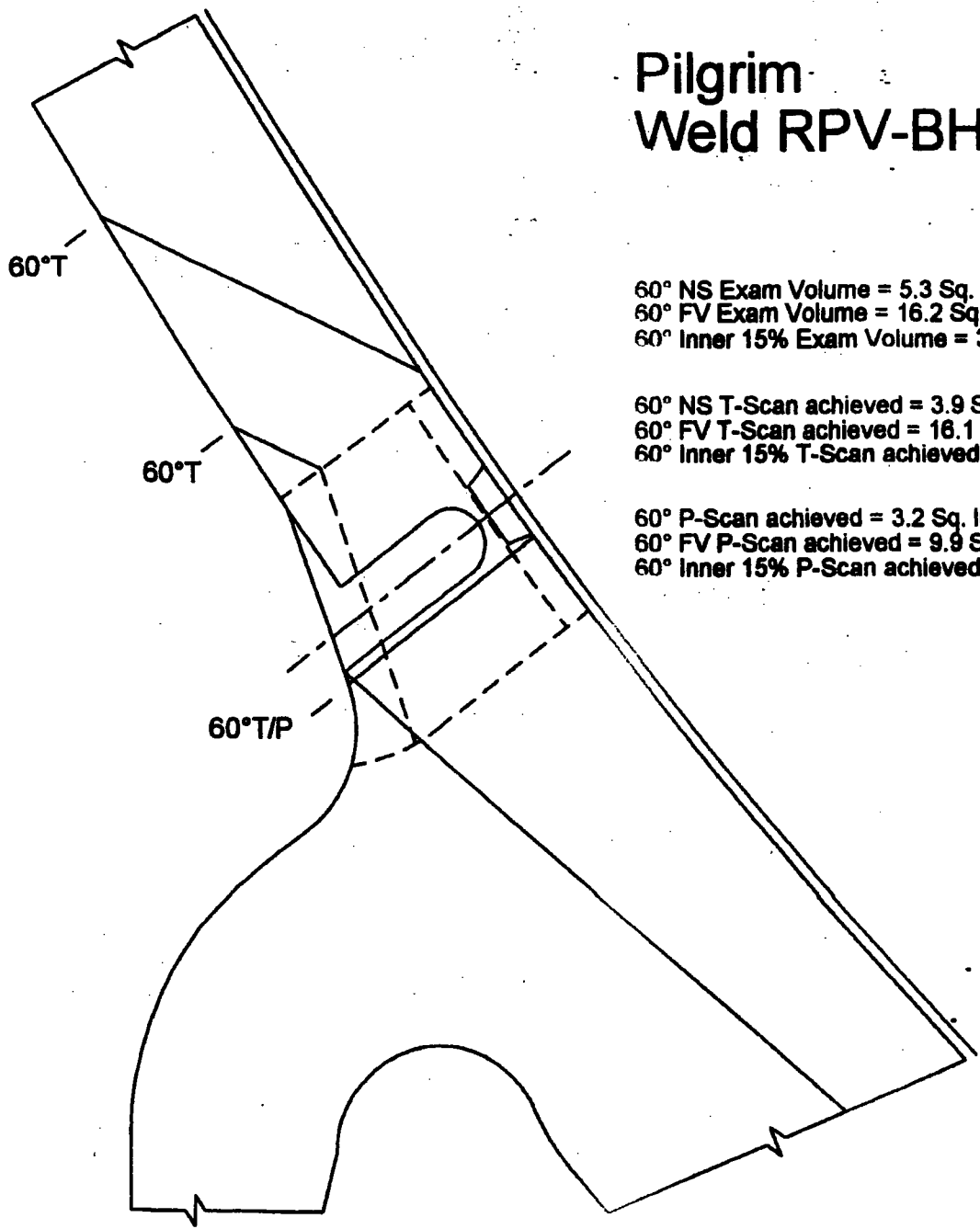

Pilgrim RF015, 2005

Handwritten signature
5-4-05



EXAMINATION RESULTS

3.1 Examination Results

No recordable indications were detected during the RFO15 examinations, reference Table 1 below. The examination results from RFO14 are also provided in Table 2. The data records for each examination are located in Appendix F (tab 9). The actual RPV ultrasonic data which was recorded with the EDAS data acquisition system was archived onto 8mm data tapes. The EDAS data tapes are also provided as attachments to this report.

Table 1. Examination Results from RFO15

Weld No.	Weld Configuration Description	Examination Results	Examination Coverage
RPV-L-2-338A	Ring 1 Vertical Weld at 78°	No Recordable Indications	73%
RPV-L-2-338C	Ring 1 Vertical Weld at 318°	No Recordable Indications	25%
RPV-L-1-338A	Ring 2 Vertical Weld at 60°	No Recordable Indications	89%
RPV-L-1-338C	Ring 2 Vertical Weld at 300°	No Recordable Indications	25%

Table 2. Examination Results from RFO14

Weld No.	Weld Configuration Description	Examination Results	Examination Coverage
RPV-L-2-338B	Ring 1 Vertical Weld at 198°	No Recordable Indications	78%
RPV-L-1-338A	Ring 2 Vertical Weld at 60°	No Recordable Indications	Partial Exam
RPV-L-1-338B	Ring 2 Vertical Weld at 180°	No Recordable Indications	100%
RPV-L-2-339A	Ring 3 Vertical Weld at 356°	No Recordable Indications	81%
RPV-L-2-339B	Ring 3 Vertical Weld at 116°	No Recordable Indications	75%
RPV-L-2-339C	Ring 3 Vertical Weld at 236°	No Recordable Indications	83%
RPV-L-1-339A	Ring 4 Vertical Weld at 60°	No Recordable Indications	97%
RPV-L-1-339B	Ring 4 Vertical Weld at 180°	1 Acceptable Indication	100%
RPV-L-1-339C	Ring 4 Vertical Weld at 300°	1 Acceptable Indication	98%
RPV-C-4-339	Upper Shell-to-Flange Weld	1 Acceptable Indication	81%

3.2 Examination Limitations

The scanning accessibility of the full length and/or width of some areas from the inside surface of the RPV was limited due to physical obstructions. A description of the examination limitations is provided below in Tables 3 and 4. The actual scan areas (scan axis and increment axis) are recorded on the ISwT Examination Records (data records).



Table 3. Examination Limitations from RFO15

Weld No.	Weld Configuration Description	Examination Limitation
RPV-L-2-338A RPV-L-2-338C	Ring 1 Vertical Weld at 78-deg Ring 1 Vertical Weld at 318-deg	Proximity of Baffle Plate & Baffle Gusset Proximity of Baffle Plate, Baffle Gusset, Core Shroud Tie Rod, & N2K Nozzle
RPV-L-1-338A RPV-L-1-338C	Ring 2 Vertical Weld at 60-deg Ring 2 Vertical Weld at 300-deg	Proximity of Jet Pump Riser Support Proximity of Jet Pump Riser Support, Surveillance Specimen Holder & Support Brackets, and Shroud Tie Rod

Table 4. Examination Limitations from RFO14

Weld No.	Weld Configuration Description	Examination Limitation
RPV-L-2-338B RPV-L-1-338A RPV-L-1-338B RPV-L-2-339A RPV-L-2-339B RPV-L-2-339C RPV-L-1-339A RPV-L-1-339B RPV-L-1-339C RPV-C-4-339	Ring 1 Vertical Weld at 198-deg Ring 2 Vertical Weld at 60-deg Ring 2 Vertical Weld at 180-deg Ring 3 Vertical Weld at 356-deg Ring 3 Vertical Weld at 116-deg Ring 3 Vertical Weld at 236-deg Ring 4 Vertical Weld at 60-deg Ring 4 Vertical Weld at 180-deg Ring 4 Vertical Weld at 300-deg Upper Shell-to-Flange Weld	Proximity of Baffle Plate Gusset Partial Examination None Proximity of FW and CS Spargers Proximity of FW and CS Spargers & ID Taper Proximity of FW and CS Spargers Proximity of N3A Nozzle & Nozzle Plug None Proximity of N3D Nozzle & Nozzle Plug Proximity of N3 Nozzles, Nozzle Plugs, Guide Rods @ 0 & 180, and Flange Configuration

3.3 Explanation of Field Data Records

In addition to the examinations being automatically recorded as described in the previous section of this report, results of the NDE activities and calibrations performed by ISwT personnel were recorded on standard ISwT forms. The field data records for each weld or area were assembled into a data package preceded by a Summary Sheet. The examination areas and Summary Sheet numbers correspond to those listed in the Summary Table and were completed while on site. Therefore, a general explanation of the individual field data forms is provided to further clarify the information contained on the summary sheet.

Page 15/240

G-1

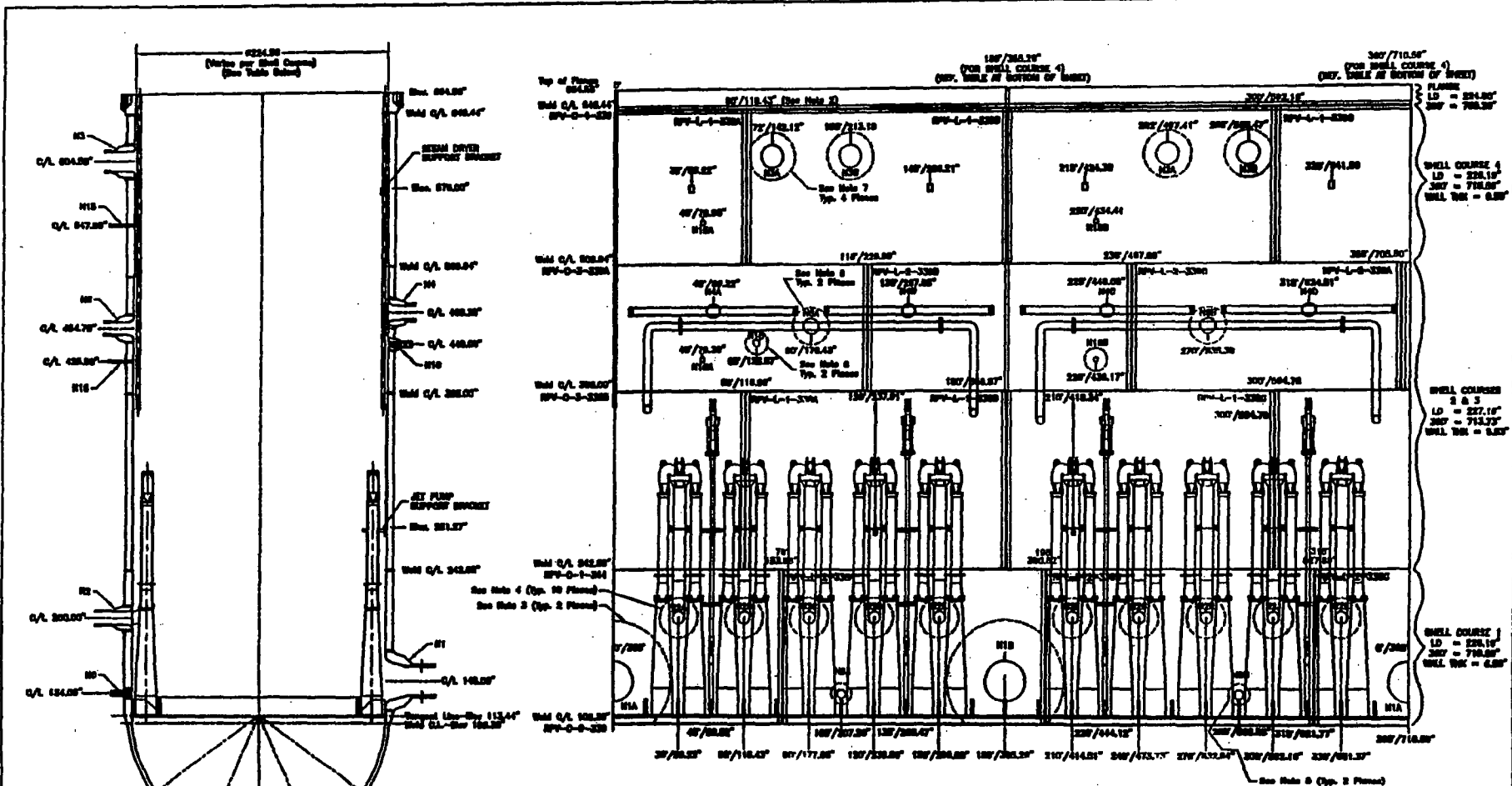

- Notes:
1. Rollout as viewed from the vessel centerline.
 2. Circumferential locations (traces) are based on the ID of the Shell Course on which the feature (i.e., vertical weld, nozzle, etc.) is located.
 3. Thickness of shell wall base metal is 7.00" in the region (102.00" diameter from N1 nozzle centerline), per Construction Engineering Dep. No. 232-345-B, Rev. E.
 4. Thickness of shell wall base metal is 7.00" in the region (114.00" diameter from N2 nozzle centerline), per Construction Engineering Dep. No. 232-345-B, Rev. E.
 5. Thickness of shell wall base metal is 7.00" in the region (114.00" diameter from N3 nozzle centerline), per Construction Engineering Dep. No. 232-345-B, Rev. E.
 6. Thickness of shell wall base metal is 8.00" in the region (133.12" diameter from N2 nozzle centerline), per Construction Engineering Dep. No. 232-345-B, Rev. E.
 7. Thickness of shell wall base metal is 7.00" in the region (142.16" diameter from N3 nozzle centerline), per Construction Engineering Dep. No. 232-345-B, Rev. E.

VESSEL INSIDE DIAMETER VARIES ACCORDING TO SHELL COURSE AS FOLLOWS:					
LOCATION	VESSEL ID	1 DEGREE =	50 DEGREES =	CRD. WELD NAME	LOCATION OF ID TRANSITION
FLANGE	224.50"	1.9931"	708.30"	RPV-C-1-330	AT WELD CENTERLINE
SHELL COURSE 4	228.18"	1.9730"	710.50"	RPV-C-3-330A	ABOVE WELD CENTERLINE
SHELL COURSE 3	227.18"	1.9828"	713.73"	RPV-C-3-330B	NO TRANSITION (SAME DIA)
SHELL COURSE 2	227.18"	1.9828"	713.73"	RPV-C-1-344	BELOW WELD CENTERLINE
SHELL COURSE 1	228.18"	1.9730"	710.50"	RPV-C-2-330	NO TRANSITION
LOWER HEAD	R=113.44"	N/A	N/A		

Pilgrim Station
 ID Vessel Rollout
 November 2002
 RPVID

ISWT EXAMINATION SUMMARY RECORD

Project No.: 02-0285

PILGRIM NUCLEAR POWER STATION

Summary Sheet No.: 000400

SITE: PILGRIM STATION
SYSTEM: REACTOR PRESSURE VESSEL
LINE/SUBASSEMBLY: RING 2 VERTICAL WELD @ 60-DEGREES
IDENTIFICATION: RPV-L-1-338A

NDE Method	Proc/Rev/Chg/ICN	NDE Examination	Calibration Sheet No.	Data Sheet No.	N O		Resolution Record	CNF Number	Remarks
					R	T			
AUT	ISWT-PDI-AUT1/0/0/1,2	AUT55T	80031,80032	exam 22-24	X	-	N/A	N/A	Examination no's 22 - 24 were performed during RFO14. AUTO for thickness measurement only.
AUT	ISWT-PDI-AUT1/0/0/1,2	AUTSLIC40T	80033,80034	exam 22-24	X	-	N/A	N/A	
AUT	ISWT-PDI-AUT1/0/0/1,2	AUTO	80035	exam 22-24	X	-	N/A	N/A	
AUT	ISWT-PDI-AUT1/0/0/1,2	AUT55T	0800301,0800302	exam 19-21	X	-	N/A	N/A	
AUT	ISWT-PDI-AUT1/0/0/1,2	AUTSLIC40T	0800303,0800304	exam 19-21	X	-	N/A	N/A	
AUT	ISWT-PDI-AUT1/0/0/1,2	AUTO	0800305	exam 19-21	X	-	N/A	N/A	
AUT	ISWT-PDI-AUT1/0/0/1,2	AUT55	0800301,0800302	exam 25-26	X	-	N/A	N/A	
AUT	ISWT-PDI-AUT1/0/0/1,2	AUTSLIC40	0800303,0800304	exam 25-26	X	-	N/A	N/A	
AUT	ISWT-PDI-AUT1/0/0/1,2	AUTO	0800305	exam 25-26	X	-	N/A	N/A	

- NOTES:
1. Weld RPV-L-1-338A was examined from the inside surface using AIRIS-21 and EDAS-II examination equipment.
 2. No recordable indications were detected during this examination.
 3. Examinations 22 - 24 performed during RFO14.
 4. Examinations 25 and 26 were divided into 2 segments, 25a & 25b; and 26a & 26b.
 5. The examination was limited due to the proximity of the jet pump riser brace, 89% examination coverage was achieved.

****UT CALIBRATION BLOCK(S)****
 D-70187-2/D70389-1

Prepared by: Steven J. Todd
 Steven J. Todd Project Engineer

Date: 4/30/05

Page 1 of 1

Page 16/240



IHI SOUTHWEST TECHNOLOGIES AUTOMATED ULTRASONIC EXAMINATION RECORD

Site/Plant: Pilgrim Nuclear Station	Weld Identification: RPV-L-1-338A	Pro/Rev/Chg/ICN: ISWT-PDI-AUT1/0/0/1,2	Examination No.: ID-19
Project No.: 02-0285	Weld Description: Ring 2 Vert @ 60°	Device Configuration: D-PNPS-102	
Mod.Conf.: A-07B	Scan Path Drawing: SPLONGSH2&3DS	Exam Date: 24 Apr. 04	Surface Temperature °F
Data Acquisition Operator (s) / SNT Level: David Kleinjan / II Alan Schaefer / N/A		Examination Time	
		Start: 1741	End: 1746
		Start: -85	End: 85

Data Acquisition

Scan Controller Parameters		Increment Axis/Arm	Planned	Actual	Scan Axis/Device	Planned	Actual	Positional Parameters	
Controller:	ID Device	Lower Limit	11266	11282	Lower Limit	23188	23188	Beam Direction:	Dn/Up
Scan:	Y Axis	Upper Limit	12526	12503	Upper Limit	27880	24464	Transducer Size:	1.00
Increment:	X Axis	Increment Interval	90		DCI	4		Code % of Overlap:	10
Mode:	Automatic Scan	Conversion Counts	100		Conversion Counts	100		Number of Scans:	15
Scan Motion:	Bi-directional	Conversion Units In.	1.00		Conversion Units In.	1.00		Device Position:	D (0)
Correction:	Default	EDAS Radius In.	113.60						

Module Parameters: A-07B Cal 03						Calibration Records:	Examination Notes:
Channel	Status	Angle	Direction	Scan Offset	Step Offset	PNS-03	
Channel 1	On	55	(-)	- 1.40(in)	- 1.21(in)	0800301	Check for limitations due to the proximity of the jet pump diffuser and the baffle plate.
Channel 2	On	55	(+)	+ 1.40(in)	- 1.21(in)	0800302	
Channel 3	On	SLIC-40	(-)	- 1.97(in)	+ 1.69(in)	0800303	
Channel 4	On	SLIC-40	(+)	+ 1.97(in)	+ 1.69(in)	0800304	Examination Remarks: Entergy/Pilgrim Procedure TP04-020
Channel 5	On	0T	(+)	+ 0.00(in)	+ 1.69(in)	0800305	
Channel 6	Off	N/A	N/A	N/A	N/A	N/A	
Channel 7	Off	N/A	N/A	N/A	N/A	N/A	
Channel 8	Off	N/A	N/A	N/A	N/A	N/A	

Data Analysis

Scan No.(s)	Increment & Scan Positions Actual				Recordable Indications			Attachment: <input type="checkbox"/> Yes <input checked="" type="checkbox"/> No	Analyst Remarks
	Increment Position		Scan Position		Yes	No	N/A		
	Start	Stop	Start	Stop					
1 - 15	11282	12503	23188	24464	Channel 1 <input type="checkbox"/>	<input checked="" type="checkbox"/>	<input type="checkbox"/>	Further Evaluation Required: <input type="checkbox"/> Yes <input checked="" type="checkbox"/> No Archive Tape/CD No.: 1A & 1B Analysis Tape/CD No.: A & B	
				Channel 2 <input type="checkbox"/>	<input checked="" type="checkbox"/>	<input type="checkbox"/>			
				Channel 3 <input type="checkbox"/>	<input checked="" type="checkbox"/>	<input type="checkbox"/>			
				Channel 4 <input type="checkbox"/>	<input checked="" type="checkbox"/>	<input type="checkbox"/>			
				Channel 5 <input type="checkbox"/>	<input type="checkbox"/>	<input checked="" type="checkbox"/>			
				Channel 6 <input type="checkbox"/>	<input type="checkbox"/>	<input checked="" type="checkbox"/>			
				Channel 7 <input type="checkbox"/>	<input type="checkbox"/>	<input checked="" type="checkbox"/>			
				Channel 8 <input type="checkbox"/>	<input type="checkbox"/>	<input checked="" type="checkbox"/>			

Analyst / SNT Level / Date: Joel G. Godwin / III / 24 Apr. 05 *Joel G. Godwin*

Page 17/240



IHI SOUTHWEST TECHNOLOGIES AUTOMATED ULTRASONIC EXAMINATION RECORD

Site/Plant : Pilgrim Nuclear Station	Weld Identification: RPV-L-1-338A	Pro/Rev/Chg/ICN: ISWT-PDI-AUT1/0/0/1,2	Examination No.: ID-20
Project No.: 02-0285	Weld Description: Ring 2 Vert @ 60°	Device Configuration: D-PNPS-102	
Mod.Conf.: A-07A	Scan Path Drawing: SPLONGSH2&3DS	Exam Date	Examination Time
Data Acquisition Operator (s) / SNT Level: David Kleinjan / II Alan Schaefer / N/A		24 Apr. 04	Start End
			Start End
		1646	1656 85 85

Data Acquisition

Scan Controller Parameters		Increment Axis/Arm	Planned	Actual	Scan Axis/Device	Planned	Actual	Positional Parameters	
Controller:	ID Device	Lower Limit	11266	11266	Lower Limit	23188	24360	Beam Direction:	Up/Dn
Scan:	Y Axis	Upper Limit	12526	12538	Upper Limit	27880	26960	Transducer Size:	1.00
Increment:	X Axis	Increment Interval	90		DCI	4		Code % of Overlap:	10
Mode:	Automatic Scan	Conversion Counts	100		Conversion Counts	100		Number of Scans:	15
Scan Motion:	Bi-directional	Conversion Units In.	1.00		Conversion Units In.	1.00		Device Position:	D (180)
Correction:	Default	EDAS Radius In.	113.60						

Module Parameters:						Cal 03	Calibration Records:	Examination Notes:
Channel	Status	Angle	Direction	Scan Offset	Step Offset			
Channel 1	On	55	(+)	+ 1.40(in)	+ 1.21(in)		PNS-03	Check for limitations due to the proximity of the jet pump diffuser and the baffle plate.
Channel 2	On	55	(-)	- 1.40(in)	+ 1.21(in)		0800301	
Channel 3	On	SLIC-40	(+)	+ 1.97(in)	- 1.69(in)		0800302	
Channel 4	On	SLIC-40	(-)	- 1.97(in)	- 1.69(in)		0800303	
Channel 5	On	0T	(+)	+ 0.00(in)	- 1.69(in)		0800304	Examination Remarks: Entergy/Pilgrim Procedure TP04-020
Channel 6	Off	N/A	N/A	N/A	N/A		0800305	
Channel 7	Off	N/A	N/A	N/A	N/A		N/A	Upper scan axis limited due to jet pump riser brace. Lower scan axis limited due to welded lug.
Channel 8	Off	N/A	N/A	N/A	N/A		N/A	

Data Analysis

Scan No.(s)	Increment & Scan Positions Actual				Recordable Indications			Attachment: <input type="checkbox"/> Yes <input checked="" type="checkbox"/> No	Analyst Remarks
	Increment Position		Scan Position		Yes	No	N/A		
1 - 15	Start	Stop	Start	Stop	Channel 1	<input type="checkbox"/>	<input checked="" type="checkbox"/>	<input type="checkbox"/>	Further Evaluation Required: <input type="checkbox"/> Yes <input checked="" type="checkbox"/> No Archive Tape/CD No.: 1A & 1B Analysis Tape/CD No.: A & B
	11266	12538	24360	26960	Channel 2	<input type="checkbox"/>	<input checked="" type="checkbox"/>	<input type="checkbox"/>	
					Channel 3	<input type="checkbox"/>	<input checked="" type="checkbox"/>	<input type="checkbox"/>	
					Channel 4	<input type="checkbox"/>	<input checked="" type="checkbox"/>	<input type="checkbox"/>	
					Channel 5	<input type="checkbox"/>	<input type="checkbox"/>	<input checked="" type="checkbox"/>	
					Channel 6	<input type="checkbox"/>	<input type="checkbox"/>	<input checked="" type="checkbox"/>	
					Channel 7	<input type="checkbox"/>	<input type="checkbox"/>	<input checked="" type="checkbox"/>	
					Channel 8	<input type="checkbox"/>	<input type="checkbox"/>	<input checked="" type="checkbox"/>	

Analyst / SNT Level / Date:

Joel G. Godwin / III / 24 Apr. 05

Paul A. Jordan

Page 18/140



IHI SOUTHWEST TECHNOLOGIES AUTOMATED ULTRASONIC EXAMINATION RECORD

Site/Plant : Pilgrim Nuclear Station	Weld Identification: RPV-L-1-338A	Pro/Rev/Chg/ICN: ISwT-PDI-AUT1/0/0/1,2	Examination No.: ID-21
Project No.: 02-0285	Weld Description: Ring 2 Vert @ 60°	Device Configuration: D-PNPS-102	
Mod.Conf.: A-07B	Scan Path Drawing: SPLONGSH2&3DS	Exam Date	Examination Time
Data Acquisition Operator (s) / SNT Level: David Kleinjan / II Alan Schaefer / N/A		24 Apr. 04	Start End
			Start End
			85 85

Data Acquisition

Scan Controller Parameters		Increment Axis/Arm	Planned	Actual	Scan Axis/Device	Planned	Actual	Positional Parameters	
Controller:	ID Device	Lower Limit	11266	11266	Lower Limit	27877	27877	Beam Direction:	Dn/Up
Scan:	Y Axis	Upper Limit	12526	12526	Upper Limit	32101	32101	Transducer Size:	1.00
Increment:	X Axis	Increment Interval	90		DCI	4		Code % of Overlap:	10
Mode:	Automatic Scan	Conversion Counts	100		Conversion Counts	100		Number of Scans:	15
Scan Motion:	Bi-directional	Conversion Units In.	1.00		Conversion Units In.	1.00		Device Position:	D (0)
Correction:	Default	EDAS Radius In.	113.60						

Module Parameters: A-07B Cal 03						Calibration Records:	Examination Notes:
Channel	Status	Angle	Direction	Scan Offset	Step Offset		
Channel 1	On	55	(-)	- 1.40(in)	- 1.21(in)	PNS-03	Check for limitations due to the proximity of the jet pump diffuser and the baffle plate.
Channel 2	On	55	(+)	+ 1.40(in)	- 1.21(in)	0800301	
Channel 3	On	SLIC-40	(-)	- 1.97(in)	+ 1.69(in)	0800302	
Channel 4	On	SLIC-40	(+)	+ 1.97(in)	+ 1.69(in)	0800303	
Channel 5	On	0T	(+)	+ 0.00(in)	+ 1.69(in)	0800304	Examination Remarks: Entergy/Pilgrim Procedure TP04-020 Limited exam due to jet pump riser brace.
Channel 6	Off	N/A	N/A	N/A	N/A	0800305	
Channel 7	Off	N/A	N/A	N/A	N/A	N/A	
Channel 8	Off	N/A	N/A	N/A	N/A	N/A	

Data Analysis

Scan No.(s)	Increment & Scan Positions Actual				Recordable Indications			Analyst Remarks	
	Increment Position		Scan Position		Yes	No	N/A	Attachment:	
1 - 15	Start	Stop	Start	Stop	Channel 1	<input type="checkbox"/>	<input checked="" type="checkbox"/>	<input type="checkbox"/>	Further Evaluation Required: <input type="checkbox"/> Yes <input checked="" type="checkbox"/> No
	11260	12526	27877	32101	Channel 2	<input type="checkbox"/>	<input checked="" type="checkbox"/>	<input type="checkbox"/>	
					Channel 3	<input type="checkbox"/>	<input checked="" type="checkbox"/>	<input type="checkbox"/>	Archive Tape/CD No.: 1A & 1B
					Channel 4	<input type="checkbox"/>	<input checked="" type="checkbox"/>	<input type="checkbox"/>	
					Channel 5	<input type="checkbox"/>	<input type="checkbox"/>	<input checked="" type="checkbox"/>	Analysis Tape/CD No.: A & B
					Channel 6	<input type="checkbox"/>	<input type="checkbox"/>	<input checked="" type="checkbox"/>	
					Channel 7	<input type="checkbox"/>	<input type="checkbox"/>	<input checked="" type="checkbox"/>	
					Channel 8	<input type="checkbox"/>	<input type="checkbox"/>	<input checked="" type="checkbox"/>	

Analyst / SNT Level / Date: Joel G. Godwin / III / 24 Apr. 05 *Joel G. Godwin*

Page 19/240



IHI SOUTHWEST TECHNOLOGIES AUTOMATED ULTRASONIC EXAMINATION RECORD

Site/Plant : Pilgrim Nuclear Station	Weld Identification: RPV-L-1-338A	Pro/Rev/Chg/ICN: ISWT-PDI-AUT1/0/0/1,2	Examination No.: ID-25a
Project No.: 02-0285	Weld Description: Ring 2 Vert @ 60°	Device Configuration: D-PNPS-101	
Mod.Conf.: A-07-1D	Scan Path Drawing: SPLONGSH2&3DS	Exam Date: 25 Apr. 05	Surface Temperature °F
Data Acquisition Operator (s) / SNT Level: Richard Riddles / II		Examination Time	Start End
		0112 0130	85 85

Data Acquisition

Scan Controller Parameters		Increment Axis/Device		Planned	Actual	Scan Axis/Arm	Planned	Actual	Positional Parameters	
Controller:	ID Device	Lower Limit	24138	24138	24138	Lower Limit	11146	11146	Beam Direction:	Cow/Cw
Scan:	X Axis	Upper Limit	27918	26298	26298	Upper Limit	12646	12646	Transducer Size:	1.00
Increment:	Y Axis	Increment Interval	90			DCI	4		Code % of Overlap:	10
Mode:	Automatic Scan	Conversion Counts	100			Conversion Counts	100		Number of Scans:	43
Scan Motion:	Bi-directional	Conversion Units In.	1.00			Conversion Units In.	1.00		Device Position:	A (0)
Correction:	Default	EDAS Radius In.	113.60							

Module Parameters:						Calibration Records:		Examination Notes:	
A-07-1D		Cal 33				PNS-33		Check for limitations due to the proximity of the jet pump diffuser and the baffle plate.	
Status	Angle	Direction	Scan Offset	Step Offset					
Channel 1	On	55	(-)	+ 7.00(in)	+ 0.00(in)	0803301			
Channel 2	On	55	(+)	- 7.00(in)	+ 0.00(in)	0803302			
Channel 3	On	SLIC-40	(-)	+ 4.40(in)	+ 1.00(in)	0803303			
Channel 4	On	SLIC-40	(+)	- 4.40(in)	- 1.00(in)	0803304			
Channel 5	On	0T	(+)	+ 4.40(in)	- 1.00(in)	0803305		Examination Remarks:	
Channel 6	Off	N/A	N/A	N/A	N/A	N/A		Entergy/Pilgrim Procedure TP04-020	
Channel 7	Off	N/A	N/A	N/A	N/A	N/A		Limited exam due to jet pump riser brace.	
Channel 8	Off	N/A	N/A	N/A	N/A	N/A			

Data Analysis

Increment & Scan Positions Actual					Recordable Indications			Analyst Remarks	
Scan No.(s)	Increment Position		Scan Position		Yes	No	N/A	Attachment:	
	Start	Stop	Start	Stop				<input type="checkbox"/> Yes <input checked="" type="checkbox"/> No	
1 - 25	24138	26298	11146	12646	Channel 1 <input type="checkbox"/>	<input checked="" type="checkbox"/>	<input type="checkbox"/>	Further Evaluation Required:	
					Channel 2 <input type="checkbox"/>	<input checked="" type="checkbox"/>	<input type="checkbox"/>	<input type="checkbox"/> Yes <input checked="" type="checkbox"/> No	
					Channel 3 <input type="checkbox"/>	<input checked="" type="checkbox"/>	<input type="checkbox"/>	Archive Tape/CD No.:	
					Channel 4 <input type="checkbox"/>	<input checked="" type="checkbox"/>	<input type="checkbox"/>	1A & 1B	
					Channel 5 <input type="checkbox"/>	<input type="checkbox"/>	<input checked="" type="checkbox"/>	Analysis Tape/CD No.:	
					Channel 6 <input type="checkbox"/>	<input type="checkbox"/>	<input checked="" type="checkbox"/>	A & B	
					Channel 7 <input type="checkbox"/>	<input type="checkbox"/>	<input checked="" type="checkbox"/>		
					Channel 8 <input type="checkbox"/>	<input type="checkbox"/>	<input checked="" type="checkbox"/>		

Analyst / SNT Level / Date: Joel G. Godwin / III / 25 Apr. 05 *Joel G. Godwin*

Rgr 20/140



IHI SOUTHWEST TECHNOLOGIES AUTOMATED ULTRASONIC EXAMINATION RECORD

Site/Plant: Pilgrim Nuclear Station	Weld Identification: RPV-L-1-338A	Pro/Rev/Chg/ICN: ISwT-PDI-AUT1/0/0/1,2	Examination No.: ID-25b
Project No.: 02-0285	Weld Description: Ring 2 Vert @ 60°	Device Configuration: D-PNPS-101	
Mod.Conf.: A-07-1C	Scan Path Drawing: SPLONGSH2&3DS	Exam Date: 25 Apr. 05	Surface Temperature °F
Data Acquisition Operator (s) / SNT Level: Richard Riddles / II		Examination Time	Start End
		0319 0324	85 85

Data Acquisition

Scan Controller Parameters		Increment Axis/Device		Planned	Actual	Scan Axis/Arm		Planned	Actual	Positional Parameters	
Controller:	ID Device	Lower Limit	24138	26298	Lower Limit	11146	11146	Beam Direction:	Cw/Ccw		
Scan:	X Axis	Upper Limit	27918	27542	Upper Limit	12646	12646	Transducer Size:	1.00		
Increment:	Y Axis	Increment Interval	90		DCI	4		Code % of Overlap:	10		
Mode:	Automatic Scan	Conversion Counts	100		Conversion Counts	100		Number of Scans:	43		
Scan Motion:	Bi-directional	Conversion Units In.	1.00		Conversion Units In.	1.00		Device Position:	A (180)		
Correction:	Default	EDAS Radius In.	113.60								

Module Parameters: A-07-1C Cal 33						Calibration Records:	Examination Notes:
Channel	Status	Angle	Direction	Scan Offset	Step Offset		
Channel 1	On	55	(+)	- 7.00(in)	+ 0.00(in)	PNS-33	Check for limitations due to the proximity of the jet pump diffuser and the baffle plate.
Channel 2	On	55	(-)	+ 7.00(in)	+ 0.00(in)	0803301	
Channel 3	On	SLIC-40	(+)	- 4.40(in)	- 1.00(in)	0803302	
Channel 4	On	SLIC-40	(-)	+ 4.40(in)	+ 1.00(in)	0803303	
Channel 5	On	0T	(+)	- 4.40(in)	+ 1.00(in)	0803304	Examination Remarks: Energy/Pilgrim Procedure TP04-020 Limited exam due to jet pump riser brace.
Channel 6	Off	N/A	N/A	N/A	N/A	N/A	
Channel 7	Off	N/A	N/A	N/A	N/A	N/A	
Channel 8	Off	N/A	N/A	N/A	N/A	N/A	

Data Analysis

Scan No.(s)	Increment & Scan Positions Actual				Recordable Indications			Attachment: <input type="checkbox"/> Yes <input checked="" type="checkbox"/> No	Further Evaluation Required: <input type="checkbox"/> Yes <input checked="" type="checkbox"/> No	Analyst Remarks
	Start	Stop	Start	Stop	Yes	No	N/A			
25 - 39	26298	27542	11146	12646	Channel 1 <input type="checkbox"/>	<input checked="" type="checkbox"/>	<input type="checkbox"/>	Archive Tape/CD No.: IA & IB Analysis Tape/CD No.: A & B		
				Channel 2 <input type="checkbox"/>	<input checked="" type="checkbox"/>	<input type="checkbox"/>				
				Channel 3 <input type="checkbox"/>	<input checked="" type="checkbox"/>	<input type="checkbox"/>				
				Channel 4 <input type="checkbox"/>	<input checked="" type="checkbox"/>	<input type="checkbox"/>				
				Channel 5 <input type="checkbox"/>	<input type="checkbox"/>	<input checked="" type="checkbox"/>				
				Channel 6 <input type="checkbox"/>	<input type="checkbox"/>	<input checked="" type="checkbox"/>				
				Channel 7 <input type="checkbox"/>	<input type="checkbox"/>	<input checked="" type="checkbox"/>				
				Channel 8 <input type="checkbox"/>	<input type="checkbox"/>	<input checked="" type="checkbox"/>				

Analyst / SNT Level / Date:

Joel G. Godwin / III / 25 Apr. 05

Joel G. Godwin

Page 21/240



IHI SOUTHWEST TECHNOLOGIES AUTOMATED ULTRASONIC EXAMINATION RECORD

Site/Plant : Pilgrim Nuclear Station	Weld Identification: RPV-L-1-338A	Pro/Rev/Chg/ICN: ISWT-PDI-AUT1/0/0/1,2	Examination No.: ID-26a
Project No.: 02-0285	Weld Description: Ring 2 Vert @ 60°	Device Configuration: D-PNPS-101	
Mod.Conf.: A-07-1D	Scan Path Drawing: SPLONGSH2&3DS	Exam Date: 25 Apr. 05	Surface Temperature °F
Data Acquisition Operator (s) / SNT Level: Richard Riddies / II		Examination Time	
		Start: 0153	End: 0210
		Start: 85	End: 85

Data Acquisition

Scan Controller Parameters		Increment Axis/Device		Planned	Actual	Scan Axis/Arm	Planned	Actual	Positional Parameters	
Controller:	ID Device	Lower Limit	27877	30307	Lower Limit	11146	11146	Beam Direction:	Ccw/Cw	
Scan:	X Axis	Upper Limit	33997	33997	Upper Limit	12646	12646	Transducer Size:	1.00	
Increment:	Y Axis	Increment Interval	90		DCI	4		Code % of Overlap:	10	
Mode:	Automatic Scan	Conversion Counts	100		Conversion Counts	100		Number of Scans:	69	
Scan Motion:	Bi-directional	Conversion Units In.	1.00		Conversion Units In.	1.00		Device Position:	A (0)	
Correction:	Default	EDAS Radius In.	113.60							

Module Parameters: A-07-1D Cal 33						Calibration Records:	Examination Notes:
Status	Angle	Direction	Scan Offset	Step Offset			
Channel 1	On	55	(-)	+ 7.00(in)	+ 0.00(in)	PNS-33	Check for limitations due to the proximity of the jet pump diffuser and the baffle plate.
Channel 2	On	55	(+)	- 7.00(in)	+ 0.00(in)	0803301	
Channel 3	On	SLIC-40	(-)	+ 4.40(in)	+ 1.00(in)	0803302	
Channel 4	On	SLIC-40	(+)	- 4.40(in)	- 1.00(in)	0803303	
Channel 5	On	OT	(+)	+ 4.40(in)	- 1.00(in)	0803304	Examination Remarks: Entergy/Pilgrim Procedure TP04-020 Limited exam due to jet pump riser brace.
Channel 6	Off	N/A	N/A	N/A	N/A	0803305	
Channel 7	Off	N/A	N/A	N/A	N/A	N/A	
Channel 8	Off	N/A	N/A	N/A	N/A	N/A	

Data Analysis

Scan No.(s)	Increment & Scan Positions Actual				Recordable Indications			Attachment: <input type="checkbox"/> Yes <input checked="" type="checkbox"/> No	Analyst Remarks
	Increment Position		Scan Position		Yes	No	N/A		
28 - 69	Start: 30307	Stop: 33997	Start: 11146	Stop: 12646	Channel 1 <input type="checkbox"/>	Channel 2 <input checked="" type="checkbox"/>	Channel 3 <input type="checkbox"/>	Further Evaluation Required: <input type="checkbox"/> Yes <input checked="" type="checkbox"/> No Archive Tape/CD No.: IA & IB Analysis Tape/CD No.: A & B	
				Channel 4 <input type="checkbox"/>	Channel 5 <input type="checkbox"/>	Channel 6 <input checked="" type="checkbox"/>			
				Channel 7 <input type="checkbox"/>	Channel 8 <input checked="" type="checkbox"/>				

Analyst / SNT Level / Date: Joel G. Godwin / III / 25 Apr. 05 *Joel G. Godwin*

00092 22/240



IHI SOUTHWEST TECHNOLOGIES AUTOMATED ULTRASONIC EXAMINATION RECORD

Site/Plant: Pilgrim Nuclear Station	Weld Identification: RPV-L-1-338A	Pro/Rev/Chg/ICN: ISwT-PDI-AUT1/0/0/1,2	Examination No.: ID-26b
Project No.: 02-0285	Weld Description: Ring 2 Vert @ 60°	Device Configuration: D-PNPS-101	
Mod.Conf.: A-07-1D	Scan Path Drawing: SPLONGSH2&3DS	Exam Date: 25 Apr. 05	Surface Temperature °F
Data Acquisition Operator (s) / SNT Level: Richard Riddles / II		Examination Time	
		Start: 0216	End: 0237
		Start: 85	End: 85

Data Acquisition

Scan Controller Parameters		Increment Axis/Device		Planned	Actual	Scan Axis/Arm		Planned	Actual	Positional Parameters	
Controller:	ID Device	Lower Limit	33907	33907	33907	Lower Limit	11146	11146	11146	Beam Direction:	CCW/CW
Scan:	X Axis	Upper Limit	40027	40027	40027	Upper Limit	12646	12646	12646	Transducer Size:	1.00
Increment:	Y Axis	Increment Interval	90			DCI	4			Code % of Overlap:	10
Mode:	Automatic Scan	Conversion Counts	100			Conversion Counts	100			Number of Scans:	69
Scan Motion:	Bi-directional	Conversion Units In.	1.00			Conversion Units In.	1.00			Device Position:	A (0)
Correction:	Default	EDAS Radius In.	113.60								

Module Parameters:						Calibration Records:		Examination Notes:	
A-07-1D		Cal 33				PNS-33		Check for limitations due to the proximity of the jet pump diffuser and the baffle plate.	
Status	Angle	Direction	Scan Offset	Step Offset					
Channel 1	On	55	(-)	+ 7.00(in)	+ 0.00(in)	0803301			
Channel 2	On	55	(+)	- 7.00(in)	+ 0.00(in)	0803302			
Channel 3	On	SLIC-40	(-)	+ 4.40(in)	+ 1.00(in)	0803303			
Channel 4	On	SLIC-40	(+)	- 4.40(in)	- 1.00(in)	0803304		Examination Remarks:	
Channel 5	On	0T	(+)	+ 4.40(in)	- 1.00(in)	0803305		Entergy/Pilgrim Procedure TP04-020	
Channel 6	Off	N/A	N/A	N/A	N/A	N/A			
Channel 7	Off	N/A	N/A	N/A	N/A	N/A			
Channel 8	Off	N/A	N/A	N/A	N/A	N/A			

Data Analysis

Increment & Scan Positions Actual					Recordable Indications			Analyst Remarks	
Scan No.(s)	Increment Position		Scan Position		Yes	No	N/A	Attachment:	
	Start	Stop	Start	Stop				<input type="checkbox"/> Yes	<input checked="" type="checkbox"/> No
1 - 69	33907	40027	11146	12646	Channel 1	<input type="checkbox"/>	<input checked="" type="checkbox"/>	<input type="checkbox"/>	Further Evaluation
					Channel 2	<input type="checkbox"/>	<input checked="" type="checkbox"/>	<input type="checkbox"/>	Required:
					Channel 3	<input type="checkbox"/>	<input checked="" type="checkbox"/>	<input type="checkbox"/>	<input type="checkbox"/> Yes <input checked="" type="checkbox"/> No
					Channel 4	<input type="checkbox"/>	<input checked="" type="checkbox"/>	<input type="checkbox"/>	Archive Tape/CD No.:
					Channel 5	<input type="checkbox"/>	<input type="checkbox"/>	<input checked="" type="checkbox"/>	1A & 1B
					Channel 6	<input type="checkbox"/>	<input type="checkbox"/>	<input checked="" type="checkbox"/>	Analysis Tape/CD No.:
					Channel 7	<input type="checkbox"/>	<input type="checkbox"/>	<input checked="" type="checkbox"/>	A & B
					Channel 8	<input type="checkbox"/>	<input type="checkbox"/>	<input checked="" type="checkbox"/>	

Analyst / SNT Level / Date: Joel G. Godwin / III / 25 Apr. 05 *Paul A. Soderum*

Page 23/140

ISwT EXAMINATION SUMMARY RECORD

Project No.: 02-0285

PILGRIM NUCLEAR POWER STATION

Summary Sheet No.: 000600

SITE: PILGRIM STATION
SYSTEM: REACTOR PRESSURE VESSEL
LINE/SUBASSEMBLY: RING 2 VERTICAL WELD @ 300-DEGREES
IDENTIFICATION: RPV-L-1-338C

NDE Method	Proc/Rev/Chg/ICN	NDE Examination	Calibration Sheet No.	Data Sheet No.	N O		Resolution Record	CNF Number	Remarks
					I	H			
AUT	ISwT-PDI-AUT1/0/0/1,2	AUT45	0803401	exam 37-38	X	-	N/A	N/A	Examination no's 35-38.
AUT	ISwT-PDI-AUT1/0/0/1,2	AUT55	0803402	exam 37-38	X	-	N/A	N/A	AUTO for thickness measurement only.
AUT	ISwT-PDI-AUT1/0/0/1,2	AUTSLIC40	0803403,0803404	exam 37-38	X	-	N/A	N/A	
AUT	ISwT-PDI-AUT1/0/0/1,2	AUTSLIC40	0803403,0803404	exam 37-38	X	-	N/A	N/A	
AUT	ISwT-PDI-AUT1/0/0/1,2	AUT55T	0802301,0802302	exam 35-36	X	-	N/A	N/A	
AUT	ISwT-PDI-AUT1/0/0/1,2	AUTSLIC40T	0802303,0800304	exam 35-36	X	-	N/A	N/A	
AUT	ISwT-PDI-AUT1/0/0/1,2	AUTO	0802305	exam 35-36	X	-	N/A	N/A	

- NOTES:
1. Weld RPV-L-1-338C was examined from the inside surface using AIRIS-21 and EDAS-II examination equipment.
 2. No recordable indications were detected during this examination.
 3. The examination was limited due to the proximity of the jet pump riser brace, specimen holder, and core shroud repair tie rod, 25% Examination coverage was achieved.

****UT CALIBRATION BLOCK(s)****
 D-70187-2/D70389-1

Prepared by: Steven J. Todd
 Steven J. Todd - Project Engineer

Date: 4/30/05

Page 1 of 1

Summary Sheet No.: 000600

ASST. Chief Admin. Files

Page 24/140



IHI SOUTHWEST TECHNOLOGIES AUTOMATED ULTRASONIC EXAMINATION RECORD

Site/Plant : Pilgrim Nuclear Station	Weld Identification: RPV-L-1-338C	Pro/Rev/Chg/ICN: ISWT-PDI-AUT1/0/0/1,2	Examination No.: ID-35a
Project No.: 02-0285	Weld Description: Ring 2 Vert @ 300°	Device Configuration: D-PNPS-101	
Mod.Conf.: A-07-1B	Scan Path Drawing: SPLONGSH2SS	Exam Date: 25 Apr. 05	Examination Time: Start 0811, End 0835
Data Acquisition Operator (s) / SNT Level: D. Kleinjan / II Alan Scheafer / N/A			Surface Temperature °F: Start 83, End 83

Scan Controller Parameters		Increment Axis/Device		Planned	Actual	Scan Axis/Arm	Planned	Actual	Positional Parameters	
Controller:	ID Device	Lower Limit	58938	58938	58958	Lower Limit	23538	23538	Beam Direction:	Dn/Up
Scan:	Y Axis	Upper Limit	60018	60018	60018	Upper Limit	40550	24878	Transducer Size:	1.00
Increment:	X Axis	Increment Interval	90			DCI	4		Code % of Overlap:	10
Mode:	Automatic Scan	Conversion Counts	100			Conversion Counts	100		Number of Scans:	13
Scan Motion:	Bi-directional	Conversion Units In.	1.00			Conversion Units In.	1.00		Device Position:	A (-90)
Correction:	Default	EDAS Radius In.	113.60							

Module Parameters: A-07-1B Cal 23						Calibration Records:	Examination Notes:
Channel	Status	Angle	Direction	Scan Offset	Step Offset		
Channel 1	On	55	(-)	+ 7.00(in)	+ 0.00(in)	PNS-23	Check for limitations due to the proximity of the jet pump, the jet pump riser bracket, the N2 nozzle, and the surveillance capsule holder.
Channel 2	On	55	(+)	- 7.00(in)	+ 0.00(in)	0802301	
Channel 3	On	SLIC-40	(-)	+ 4.40(in)	- 1.00(in)	0802302	
Channel 4	On	SLIC-40	(+)	- 4.40(in)	+ 1.00(in)	0802303	
Channel 5	On	0T	(+)	+ 4.40(in)	+ 1.00(in)	0802304	Examination Remarks:
Channel 6	Off	N/A	N/A	N/A	N/A	0802305	Entergy/Pilgrim Procedure TP04-020
Channel 7	Off	N/A	N/A	N/A	N/A	N/A	Exam continued on exam ID-35b.
Channel 8	Off	N/A	N/A	N/A	N/A	N/A	

Increment & Scan Positions Actual					Recordable Indications			Analyst Remarks	
Scan No.(s)	Increment Position		Scan Position		Yes	No	N/A	Attachment: <input type="checkbox"/> Yes <input checked="" type="checkbox"/> No	Further Evaluation Required: <input type="checkbox"/> Yes <input checked="" type="checkbox"/> No
	Start	Stop	Start	Stop					
1 - 13	58938	60018	23538	24878	Channel 1 <input type="checkbox"/>	Channel 2 <input checked="" type="checkbox"/>	Channel 3 <input type="checkbox"/>	Archive Tape/CD No.: 1A & 1B	
					Channel 4 <input type="checkbox"/>	Channel 5 <input type="checkbox"/>	Channel 6 <input checked="" type="checkbox"/>	Analysis Tape/CD No.: A & B	
					Channel 7 <input type="checkbox"/>	Channel 8 <input type="checkbox"/>			

Analyst / SNT Level / Date: Joel G. Godwin / III / 25 Apr. 05 *Paul S. Jordan*

Page 25/240



IHI SOUTHWEST TECHNOLOGIES AUTOMATED ULTRASONIC EXAMINATION RECORD

Site/Plant : Pilgrim Nuclear Station	Weld Identification: RPV-L-1-338C	Pro/Rev/Chg/ICN: ISWT-PDI-AUT1/0/0/1,2	Examination No.: ID-35b
Project No.: 02-0285	Weld Description: Ring 2 Vert @ 300°	Device Configuration: D-PNPS-101	
Mod.Conf.: A-07-1B	Scan Path Drawing: SPLONGSH2SS	Exam Date: 25 Apr. 05	Surface Temperature °F:
Data Acquisition Operator (s) / SNT Level: D. Kleinjan / II Alan Scheafer / N/A			Start: 83 End: 83
			Start: 0845 End: 0903

Scan Controller Parameters		Increment Axis/Device		Planned	Actual	Scan Axis/Arm	Planned	Actual	Positional Parameters	
Controller:	ID Device	Lower Limit	58938	58938	58943	Lower Limit	23538	24642	Beam Direction:	Dn/Up
Scan:	Y Axis	Upper Limit	60018	60038	60038	Upper Limit	40550	25342	Transducer Size:	1.00
Increment:	X Axis	Increment Interval	90			DCI	4		Code % of Overlap:	10
Mode:	Automatic Scan	Conversion Counts	100			Conversion Counts	100		Number of Scans:	13
Scan Motion:	Bi-directional	Conversion Units In.	1.00			Conversion Units In.	1.00		Device Position:	A (-90)
Correction:	Default	EDAS Radius In.	113.60							

Module Parameters: A-07-1B Cal 23						Calibration Records:	Examination Notes:
Channel	Status	Angle	Direction	Scan Offset	Step Offset		
Channel 1	On	55	(-)	+ 7.00(in)	+ 0.00(in)	PNS-23	Check for limitations due to the proximity of the jet pump, the jet pump riser bracket, the N2 nozzle, and the surveillance capsule holder.
Channel 2	On	55	(+)	- 7.00(in)	+ 0.00(in)	0802301	
Channel 3	On	SLIC-40	(-)	+ 4.40(in)	- 1.00(in)	0802302	
Channel 4	On	SLIC-40	(+)	- 4.40(in)	+ 1.00(in)	0802303	Examination Remarks: Entergy/Pilgrim Procedure TP04-020 Exam continued on exam ID-35c.
Channel 5	On	0T	(+)	+ 4.40(in)	+ 1.00(in)	0802304	
Channel 6	Off	N/A	N/A	N/A	N/A	N/A	
Channel 7	Off	N/A	N/A	N/A	N/A	N/A	
Channel 8	Off	N/A	N/A	N/A	N/A	N/A	

Increment & Scan Positions Actual					Recordable Indications			Analyst Remarks	
Scan No.(s)	Increment Position		Scan Position		Yes	No	N/A	Attachment: <input type="checkbox"/> Yes <input checked="" type="checkbox"/> No	
	Start	Stop	Start	Stop					
1 - 13	58943	60038	24642	25342	Channel 1 <input type="checkbox"/>	<input checked="" type="checkbox"/>	<input type="checkbox"/>	Further Evaluation Required: <input type="checkbox"/> Yes <input checked="" type="checkbox"/> No Archive Tape/CD No.: 1A & 1B Analysis Tape/CD No.: A & B	
					Channel 2 <input type="checkbox"/>	<input checked="" type="checkbox"/>	<input type="checkbox"/>		
					Channel 3 <input type="checkbox"/>	<input checked="" type="checkbox"/>	<input type="checkbox"/>		
					Channel 4 <input type="checkbox"/>	<input checked="" type="checkbox"/>	<input type="checkbox"/>		
					Channel 5 <input type="checkbox"/>	<input type="checkbox"/>	<input checked="" type="checkbox"/>		
					Channel 6 <input type="checkbox"/>	<input type="checkbox"/>	<input checked="" type="checkbox"/>		
					Channel 7 <input type="checkbox"/>	<input type="checkbox"/>	<input checked="" type="checkbox"/>		
					Channel 8 <input type="checkbox"/>	<input type="checkbox"/>	<input checked="" type="checkbox"/>		

Analyst / SNT Level / Date: Joel G. Godwin / III / 25 Apr. 05 *Joel G. Godwin*

Page 26/140



IHI SOUTHWEST TECHNOLOGIES AUTOMATED ULTRASONIC EXAMINATION RECORD

Site/Plant : Pilgrim Nuclear Station	Weld Identification: RPV-L-1-338C	Pro/Rev/Chg/ICN: ISwT-PDI-AUT1/0/0/1,2	Examination No.: ID-35c
Project No.: 02-0285	Weld Description: Ring 2 Vert @ 300°	Device Configuration: D-PNPS-101	
Mod.Conf.: A-07-1B	Scan Path Drawing: SPLONGSHZSS	Exam Date: 25 Apr. 05	Surface Temperature °F:
Data Acquisition Operator (s) / SNT Level: D. Kleinjan / II Alan Scheafer / N/A		Examination Time:	
		Start: 0938	End: 0940
		Start: 80	End: 80

Data Acquisition

Scan Controller Parameters		Increment Axis/Device		Planned	Actual	Scan Axis/Arm	Planned	Actual	Positional Parameters	
Controller:	ID Device	Lower Limit	58938	59935	59935	Lower Limit	23538	30942	Beam Direction:	Dn/Up
Scan:	Y Axis	Upper Limit	60018	59245	59245	Upper Limit	40550	31526	Transducer Size:	1.00
Increment:	X Axis	Increment Interval	90			DCI	4		Code % of Overlap:	10
Mode:	Automatic Scan	Conversion Counts	100			Conversion Counts	100		Number of Scans:	13
Scan Motion:	Bi-directional	Conversion Units In.	1.00			Conversion Units In.	1.00		Device Position:	A (-90)
Correction:	Default	EDAS Radius In.	113.60							

Module Parameters:						Cal 23		Calibration Records:		Examination Notes:	
Status	Angle	Direction	Scan Offset	Step Offset							
Channel 1	On	55	(-)	+ 7.00(in)	+ 0.00(in)			PNS-23	Check for limitations due to the proximity of the jet pump, the jet pump riser bracket, the N2 nozzle, and the surveillance capsule holder.		
Channel 2	On	55	(+)	- 7.00(in)	+ 0.00(in)			0802301			
Channel 3	On	SLIC-40	(-)	+ 4.40(in)	- 1.00(in)			0802302			
Channel 4	On	SLIC-40	(+)	- 4.40(in)	+ 1.00(in)			0802303			
Channel 5	On	0T	(+)	+ 4.40(in)	+ 1.00(in)			0802304	Examination Remarks:		
Channel 6	Off	N/A	N/A	N/A	N/A			0802305	Entergy/Pilgrim Procedure TP04-020		
Channel 7	Off	N/A	N/A	N/A	N/A			N/A	No exam from 25320 to 30942 due to specimen holder and riser support brackets.		
Channel 8	Off	N/A	N/A	N/A	N/A			N/A			

Data Analysis

Increment & Scan Positions Actual					Recordable Indications			Analyst Remarks			
Scan No.(s)	Increment Position		Scan Position		Yes	No	N/A	Attachment: <input type="checkbox"/> Yes <input checked="" type="checkbox"/> No Further Evaluation Required: <input type="checkbox"/> Yes <input checked="" type="checkbox"/> No Archive Tape/CD No.: 1A & 1B Analysis Tape/CD No.: A & B			
	Start	Stop	Start	Stop							
1 - 5	58933	59245	30942	31526	<input type="checkbox"/>	<input checked="" type="checkbox"/>	<input type="checkbox"/>				
					<input type="checkbox"/>	<input checked="" type="checkbox"/>	<input type="checkbox"/>				
					<input type="checkbox"/>	<input checked="" type="checkbox"/>	<input type="checkbox"/>				
					<input type="checkbox"/>	<input type="checkbox"/>	<input checked="" type="checkbox"/>				
					<input type="checkbox"/>	<input type="checkbox"/>	<input checked="" type="checkbox"/>				
					<input type="checkbox"/>	<input type="checkbox"/>	<input checked="" type="checkbox"/>				
					<input type="checkbox"/>	<input type="checkbox"/>	<input checked="" type="checkbox"/>				

Analyst / SNT Level / Date: Joel G. Godwin / III / 25 Apr. 05 *Joel G. Godwin*

Page 27/240



IHI SOUTHWEST TECHNOLOGIES AUTOMATED ULTRASONIC EXAMINATION RECORD

Site/Plant : Pilgrim Nuclear Station	Weld Identification: RPV-L-1-338C	Pro/Rev/Chg/ICN: ISwT-PDI-AUT1/0/0/1,2	Examination No.: ID-36
Project No.: 02-0285	Weld Description: Ring 2 Vert @ 300°	Device Configuration: D-PNPS-101	
Mod.Conf.: A-07-1A	Scan Path Drawing: SPLONGSH2SS	Exam Date: 25 Apr. 05	Examination Time: Start: N/A, End: N/A
Data Acquisition Operator (s) / SNT Level: Alan Schaefer / N/A			Surface Temperature °F: Start: N/A, End: N/A

Data Acquisition

Scan Controller Parameters		Increment Axis/Arm	Planned	Actual	Scan Axis/Device	Planned	Actual	Positional Parameters	
Controller:	ID Device	Lower Limit	58938	N/A	Lower Limit	23538	N/A	Beam Direction:	Up/Dn
Scan:	Y Axis	Upper Limit	60018	N/A	Upper Limit	40550	N/A	Transducer Size:	1.00
Increment:	X Axis	Increment Interval	90		DCI	4		Code % of Overlap:	10
Mode:	Automatic Scan	Conversion Counts	100		Conversion Counts	100		Number of Scans:	13
Scan Motion:	Bi-directional	Conversion Units In.	1.00		Conversion Units In.	1.00		Device Position:	A (90)
Correction:	Default	EDAS Radius In.	113.60						

Module Parameters: A-07-1A Cal 23						Calibration Records:	Examination Notes:
Channel	Status	Angle	Direction	Scan Offset	Step Offset		
Channel 1	On	55	(+)	- 7.00(in)	+ 0.00(in)	PNS-23	Check for limitations due to the proximity of the jet pump, the jet pump riser bracket, the N2 nozzle, and the surveillance capsule holder.
Channel 2	On	55	(-)	+ 7.00(in)	+ 0.00(in)	0802301	
Channel 3	On	SLIC-40	(+)	- 4.40(in)	+ 1.00(in)	0802302	
Channel 4	On	SLIC-40	(-)	+ 4.40(in)	- 1.00(in)	0802303	
Channel 5	On	0T	(+)	- 4.40(in)	- 1.00(in)	0802304	
Channel 6	On	0T	(+)	+ 4.40(in)	+ 1.00(in)	0802305	Examination Remarks: Entergy/Pilgrim Procedure TP04-020 NO EXAMINATION DUE TO SHROUD TIE ROD REPAIR MECHANISM
Channel 7	Off	N/A	N/A	N/A	N/A	0802306	
Channel 8	Off	N/A	N/A	N/A	N/A	N/A	

Data Analysis

Scan No.(s)	Increment & Scan Positions Actual				Recordable Indications			Attachment: <input type="checkbox"/> Yes <input checked="" type="checkbox"/> No	Further Evaluation Required: <input type="checkbox"/> Yes <input checked="" type="checkbox"/> No	Analyst Remarks
	Increment Position		Scan Position		Yes	No	N/A			
	Start	Stop	Start	Stop						
N/A	N/A	N/A	N/A	N/A	N/A	Channel 1	<input type="checkbox"/>	<input type="checkbox"/>	<input checked="" type="checkbox"/>	
						Channel 2	<input type="checkbox"/>	<input type="checkbox"/>	<input checked="" type="checkbox"/>	
						Channel 3	<input type="checkbox"/>	<input type="checkbox"/>	<input checked="" type="checkbox"/>	
						Channel 4	<input type="checkbox"/>	<input type="checkbox"/>	<input checked="" type="checkbox"/>	
						Channel 5	<input type="checkbox"/>	<input type="checkbox"/>	<input checked="" type="checkbox"/>	
						Channel 6	<input type="checkbox"/>	<input type="checkbox"/>	<input checked="" type="checkbox"/>	
						Channel 7	<input type="checkbox"/>	<input type="checkbox"/>	<input checked="" type="checkbox"/>	
						Channel 8	<input type="checkbox"/>	<input type="checkbox"/>	<input checked="" type="checkbox"/>	

Analyst / SNT Level / Date: Joel G. Godwin / III / 25 Apr. 05 *Joel G. Godwin*

Page 28/240



IHI SOUTHWEST TECHNOLOGIES AUTOMATED ULTRASONIC EXAMINATION RECORD

Site/Plant : Pilgrim Nuclear Station	Weld Identification: RPV-L-1-338C	Pro/Rev/Chg/ICN: ISwT-PDI-AUT1/0/0/1,2	Examination No.: ID-37a
Project No.: 02-0285	Weld Description: Ring 2 Vert @ 300°	Device Configuration: D-PNPS-102	
Mod.Conf.: A-08C	Scan Path Drawing: SPLONGSH2SS	Exam Date: 25 Apr. 05	Surface Temperature °F:
Data Acquisition Operator (s) / SNT Level: D. Kleinjan / II Alan Schaefer / N/A		Examination Time:	
		Start: 1340	End: 1414
		Start: 88	End: 88

Data Acquisition

Scan Controller Parameters		Increment Axis/Arm	Planned	Actual	Scan Axis/Device	Planned	Actual	Positional Parameters	
Controller:	ID Device	Lower Limit	24069	24068	Lower Limit	58396	58396	Beam Direction:	Cw
Scan:	X Axis	Upper Limit	40089	25766	Upper Limit	60020	60020	Transducer Size:	1.00
Increment:	Y Axis	Increment Interval	90		DCI	4.		Code % of Overlap:	10
Mode:	Automatic Scan	Conversion Counts	100		Conversion Counts	100		Number of Scans:	179
Scan Motion:	Bi-directional	Conversion Units In.	1.00		Conversion Units In.	1.00		Device Position:	D (-90)
Correction:	Default	EDAS Radius In.	113.60						

Module Parameters:						Calibration Records:		Examination Notes:	
Status	Angle	Direction	Scan Offset	Step Offset					
Channel 1	On	45	(+)	+ 1.40(in)	- 1.21(in)	PNS-34		Check for limitations due to the proximity of the jet pump, the jet	
Channel 2	On	55	(+)	- 1.40(in)	- 1.21(in)	0803401		pump riser bracket, the N2 nozzle, and the surveillance capsule	
Channel 3	On	SLIC-40	(+)	+ 1.97(in)	+ 1.69(in)	0803402		holder.	
Channel 4	On	SLIC-40	(+)	- 1.97(in)	+ 1.69(in)	0803403			
Channel 5	On	SLIC-40	(-)	+ 0.00(in)	+ 1.69(in)	0803404		Examination Remarks:	
Channel 6	Off	N/A	N/A	N/A	N/A	0803405		Entergy/Pilgrim Procedure TP04-020	
Channel 7	Off	N/A	N/A	N/A	N/A	N/A		Exam limited due to surveillance capsule holder.	
Channel 8	Off	N/A	N/A	N/A	N/A	N/A		Continued on exam ID-37b.	

Data Analysis

Increment & Scan Positions Actual					Recordable Indications			Analyst Remarks	
Scan No.(s)	Increment Position		Scan Position		Yes	No	N/A		
	Start	Stop	Start	Stop					
1 - 17	24068	25548	58396	60020	Channel 1 <input type="checkbox"/>	<input checked="" type="checkbox"/>	<input type="checkbox"/>	Attachment:	
18 - 20	25638	25766	58396	59430	Channel 2 <input type="checkbox"/>	<input checked="" type="checkbox"/>	<input type="checkbox"/>	<input type="checkbox"/> Yes <input checked="" type="checkbox"/> No	
					Channel 3 <input type="checkbox"/>	<input checked="" type="checkbox"/>	<input type="checkbox"/>	Further Evaluation	
					Channel 4 <input type="checkbox"/>	<input checked="" type="checkbox"/>	<input type="checkbox"/>	Required:	
					Channel 5 <input type="checkbox"/>	<input checked="" type="checkbox"/>	<input type="checkbox"/>	<input type="checkbox"/> Yes <input checked="" type="checkbox"/> No	
					Channel 6 <input type="checkbox"/>	<input type="checkbox"/>	<input checked="" type="checkbox"/>	Archive Tape/CD No.:	
					Channel 7 <input type="checkbox"/>	<input type="checkbox"/>	<input checked="" type="checkbox"/>	2A & 2B	
					Channel 8 <input type="checkbox"/>	<input type="checkbox"/>	<input checked="" type="checkbox"/>	Analysis Tape/CD No.:	
								A & B	

Analyst / SNT Level / Date: Joel G. Godwin / III / 25 Apr. 05 *Joel G. Godwin*

Page 29/140



IHI SOUTHWEST TECHNOLOGIES AUTOMATED ULTRASONIC EXAMINATION RECORD

Site/Plant : Pilgrim Nuclear Station	Weld Identification: RPV-L-1-338C	Pro/Rev/Chg/ICN: ISWT-PDI-AUT1/0/0/1,2	Examination No.: ID-37b
Project No.: 02-0285	Weld Description: Ring 2 Vert @ 300°	Device Configuration: D-PNPS-102	
Mod.Conf.: A-08C	Scan Path Drawing: SPLONGSH2SS	Exam Date: 25 Apr. 05	Surface Temperature °F
Data Acquisition Operator (s) / SNT Level: D. Kleinjan / II Alan Schaefer / N/A		Examination Time	Start End
		1431 1619	88 88

Data Acquisition

Scan Controller Parameters		Increment Axis/Arm	Planned	Actual	Scan Axis/Device	Planned	Actual	Positional Parameters	
Controller:	ID Device	Lower Limit	24069	31163	Lower Limit	58396	58396	Beam Direction:	Cw
Scan:	X Axis	Upper Limit	40089	40082	Upper Limit	60020	60020	Transducer Size:	1.00
Increment:	Y Axis	Increment Interval	90		DCI	4.		Code % of Overlap:	10
Mode:	Automatic Scan	Conversion Counts	100		Conversion Counts	100		Number of Scans:	179
Scan Motion:	Bi-directional	Conversion Units In.	1.00		Conversion Units In.	1.00		Device Position:	D (-90)
Correction:	Default	EDAS Radius In.	113.60						

Module Parameters:						Calibration Records:	Examination Notes:
	A-08C	Cal 34					
Channel	Status	Angle	Direction	Scan Offset	Step Offset		
Channel 1	On	45	(+)	+ 1.40(in)	- 1.21(in)	PNS-34	Check for limitations due to the proximity of the jet pump, the jet pump riser bracket, the N2 nozzle, and the surveillance capsule holder.
Channel 2	On	55	(+)	- 1.40(in)	- 1.21(in)	0803401	
Channel 3	On	SLIC-40	(+)	+ 1.97(in)	+ 1.69(in)	0803402	
Channel 4	On	SLIC-40	(+)	- 1.97(in)	+ 1.69(in)	0803403	
Channel 5	On	SLIC-40	(-)	+ 0.00(in)	+ 1.69(in)	0803404	
Channel 6	Off	N/A	N/A	N/A	N/A	0803405	Examination Remarks: Energy/Pilgrim Procedure TP04-020 Exam limited due to surveillance capsule holder and holder support bracket.
Channel 7	Off	N/A	N/A	N/A	N/A	N/A	
Channel 8	Off	N/A	N/A	N/A	N/A	N/A	

Data Entry

Scan No.(s)	Increment & Scan Positions Actual				Recordable Indications			Attachment:	Analyst Remarks
	Increment Position		Scan Position		Yes	No	N/A		
	Start	Stop	Start	Stop	Channel 1	<input type="checkbox"/>	<input checked="" type="checkbox"/>	<input type="checkbox"/>	<input type="checkbox"/> Yes <input checked="" type="checkbox"/> No Further Evaluation Required: <input type="checkbox"/> Yes <input checked="" type="checkbox"/> No Archive Tape/CD No.: 2A & 2B Analysis Tape/CD No.: A & B
80 - 106	31163	33546	58396	59200	Channel 2	<input type="checkbox"/>	<input checked="" type="checkbox"/>	<input type="checkbox"/>	
107 - 120	33636	34729	58396	58912	Channel 3	<input type="checkbox"/>	<input checked="" type="checkbox"/>	<input type="checkbox"/>	
121 - 171	34819	39329	58396	59200	Channel 4	<input type="checkbox"/>	<input checked="" type="checkbox"/>	<input type="checkbox"/>	
172 - 179	39419	40082	58396	60020	Channel 5	<input type="checkbox"/>	<input checked="" type="checkbox"/>	<input type="checkbox"/>	
					Channel 6	<input type="checkbox"/>	<input type="checkbox"/>	<input checked="" type="checkbox"/>	
					Channel 7	<input type="checkbox"/>	<input type="checkbox"/>	<input checked="" type="checkbox"/>	
					Channel 8	<input type="checkbox"/>	<input type="checkbox"/>	<input checked="" type="checkbox"/>	

Analyst / SNT Level / Date: Joel G. Godwin / III / 25 Apr. 05 *Jul A. Jordan*

Page 30/40



IHI SOUTHWEST TECHNOLOGIES AUTOMATED ULTRASONIC EXAMINATION RECORD

Site/Plant : Pilgrim Nuclear Station	Weld Identification: RPV-L-1-338C	Pro/Rev/Chg/ICN: ISwT-PDI-AUT1/0/0/1,2	Examination No.: ID-38
Project No.: 02-0285	Weld Description: Ring 2 Vert @ 300°	Device Configuration: D-PNPS-102	
Mod.Conf.: A-08D	Scan Path Drawing: SPLONGSH2SS	Exam Date: 25 Apr. 05	Surface Temperature °F
Data Acquisition Operator (s) / SNT Level: David Kleinjan / II		Examination Time	Start End
		N/A N/A	N/A N/A

Scan Controller Parameters		Increment Axis/Arm	Planned	Actual	Scan Axis/Device	Planned	Actual	Positional Parameters	
Controller: ID Device		Lower Limit	24069	N/A	Lower Limit	58936	N/A	Beam Direction:	Ccw
Scan: X Axis		Upper Limit	40089	N/A	Upper Limit	60560	N/A	Transducer Size:	1.00
Increment: Y Axis		Increment Interval	90		DCI	4		Code % of Overlap:	10
Mode: Automatic Scan		Conversion Counts	100		Conversion Counts	100		Number of Scans:	179
Scan Motion: Bi-directional		Conversion Units In.	1.00		Conversion Units In.	1.00		Device Position:	D (90)
Correction: Default		EDAS Radius In.	113.60						

Module Parameters:						Calibration Records:	Examination Notes:
A-08D		Cal 34				PNS-34	Check for limitations due to the proximity of the jet pump, the jet pump riser bracket, the N2 nozzle, and the surveillance capsule holder.
Status	Angle	Direction	Scan Offset	Step Offset	0803401		
Channel 1	On	45	(-)	- 1.40(in)	+ 1.21(in)	0803402	Examination Remarks: Entergy/Pilgrim Procedure TP04-020
Channel 2	On	55	(-)	+ 1.40(in)	+ 1.21(in)	0803403	
Channel 3	On	SLIC-40	(-)	- 1.97(in)	- 1.69(in)	0803404	
Channel 4	On	SLIC-40	(-)	+ 1.97(in)	- 1.69(in)	0803405	
Channel 5	On	SLIC-40	(+)	+ 0.00(in)	- 1.69(in)	N/A	
Channel 6	Off	N/A	N/A	N/A	N/A	N/A	NO EXAMINATION DUE TO SHROUD TIE ROD REPAIR MECHANISM
Channel 7	Off	N/A	N/A	N/A	N/A	N/A	
Channel 8	Off	N/A	N/A	N/A	N/A	N/A	

Scan No.(s)	Increment & Scan Positions Actual				Recordable Indications			Attachment: <input type="checkbox"/> Yes <input checked="" type="checkbox"/> No	Analyst Remarks
	Increment Position		Scan Position		Yes	No	N/A		
	Start	Stop	Start	Stop	Channel 1	<input type="checkbox"/>	<input type="checkbox"/>	<input checked="" type="checkbox"/>	Further Evaluation Required: <input type="checkbox"/> Yes <input checked="" type="checkbox"/> No Archive Tape/CD No.: N/A Analysis Tape/CD No.: N/A
N/A	N/A	N/A	N/A	N/A	Channel 2	<input type="checkbox"/>	<input type="checkbox"/>	<input checked="" type="checkbox"/>	
					Channel 3	<input type="checkbox"/>	<input type="checkbox"/>	<input checked="" type="checkbox"/>	
					Channel 4	<input type="checkbox"/>	<input type="checkbox"/>	<input checked="" type="checkbox"/>	
					Channel 5	<input type="checkbox"/>	<input type="checkbox"/>	<input checked="" type="checkbox"/>	
					Channel 6	<input type="checkbox"/>	<input type="checkbox"/>	<input checked="" type="checkbox"/>	
					Channel 7	<input type="checkbox"/>	<input type="checkbox"/>	<input checked="" type="checkbox"/>	
					Channel 8	<input type="checkbox"/>	<input type="checkbox"/>	<input checked="" type="checkbox"/>	

Analyst / SNT Level / Date: Joel G. Godwin / III / 25 Apr. 05 *Joel G. Godwin*

Page 31/34



IHI SOUTHWEST TECHNOLOGIES AUTOMATED ULTRASONIC EXAMINATION RECORD

Site/Plant : Pilgrim Nuclear Station	Weld Identification: RPV-L-1-338C	Pro/Rev/Chg/ICN: ISwT-PDI-AUT 1/0/0/1,2	Examination No.: ID-38bDS
Project No.: 02-0285	Weld Description: Ring 2 Vert @ 300°	Device Configuration: D-PNPS-101	
Mod.Conf.: A-07-1D	Scan Path Drawing: SPLONGSH2&3DS	Exam Date: 25 Apr. 05	Examination Time: Start 0629, End 0637
Data Acquisition Operator (s) / SNT Level: Richard Riddles / II			Surface Temperature °F: Start 85, End 85

Data Acquisition

Scan Controller Parameters		Increment Axis/Device		Planned	Actual	Scan Axis/Arm	Planned	Actual	Positional Parameters	
Controller:	ID Device	Lower Limit	33907	39397	39397	Lower Limit	58728	58728	Beam Direction:	CCW/CW
Scan:	X Axis	Upper Limit	40027	40098	40098	Upper Limit	60228	60228	Transducer Size:	1.00
Increment:	Y Axis	Increment Interval	90			DCI	4		Code % of Overlap:	10
Mode:	Automatic Scan	Conversion Counts	100			Conversion Counts	100		Number of Scans:	69
Scan Motion:	Bi-directional	Conversion Units In.	1.00			Conversion Units In.	1.00		Device Position:	A (0)
Correction:	Default	EDAS Radius In.	113.60							

Module Parameters:						Calibration Records:	Examination Notes:
Status	A-07-1D	Cal 33	Direction	Scan Offset	Step Offset		
Channel 1	On	55	(-)	+ 7.00(in)	+ 0.00(in)	PNS-33	Check for limitations due to the proximity of the jet pump diffuser and the baffle plate.
Channel 2	On	55	(+)	- 7.00(in)	+ 0.00(in)	0803301	
Channel 3	On	SLIC-40	(-)	+ 4.40(in)	+ 1.00(in)	0803302	
Channel 4	On	SLIC-40	(+)	- 4.40(in)	- 1.00(in)	0803303	
Channel 5	On	0T	(+)	+ 4.40(in)	- 1.00(in)	0803304	Examination Remarks: Entergy/Pilgrim Procedure TP04-020 Limited exam due to specimen bracket.
Channel 6	Off	N/A	N/A	N/A	N/A	0803305	
Channel 7	Off	N/A	N/A	N/A	N/A	N/A	
Channel 8	Off	N/A	N/A	N/A	N/A	N/A	

Data Analysis

Scan No.(s)	Increment & Scan Positions Actual				Recordable Indications			Attachment:	Analyst Remarks
	Increment Position		Scan Position		Yes	No	N/A		
62-70	Start	Stop	Start	Stop	Channel 1	<input type="checkbox"/>	<input checked="" type="checkbox"/>	<input type="checkbox"/>	Required: <input type="checkbox"/> Yes <input checked="" type="checkbox"/> No Archive Tape/CD No.: 1A & 1B Analysis Tape/CD No.: A & B
	39397	40098	60228	60228	Channel 2	<input type="checkbox"/>	<input checked="" type="checkbox"/>	<input type="checkbox"/>	
					Channel 3	<input type="checkbox"/>	<input checked="" type="checkbox"/>	<input type="checkbox"/>	
					Channel 4	<input type="checkbox"/>	<input checked="" type="checkbox"/>	<input type="checkbox"/>	
					Channel 5	<input type="checkbox"/>	<input type="checkbox"/>	<input checked="" type="checkbox"/>	
					Channel 6	<input type="checkbox"/>	<input type="checkbox"/>	<input checked="" type="checkbox"/>	
					Channel 7	<input type="checkbox"/>	<input type="checkbox"/>	<input checked="" type="checkbox"/>	
					Channel 8	<input type="checkbox"/>	<input type="checkbox"/>	<input checked="" type="checkbox"/>	

Analyst / SNT Level / Date: Joel G. Godwin / III / 25 Apr. 05 *Joel A. Godwin*

Page 32/140

ISWT EXAMINATION SUMMARY RECORD

Project No.: 02-0285

PILGRIM STATION

Summary Sheet No.: 000100

SITE: PILGRIM STATION
SYSTEM: REACTOR PRESSURE VESSEL
LINE/SUBASSEMBLY: RING 1 VERTICAL WELD @ 78-DEGREES
IDENTIFICATION: RPV-L-2-338A

NDE Method	Proc/Rev/Chg/ICN	NDE Examination	Calibration Sheet No.	Data Sheet No.	N O		Resolution Record	CNF Number	Remarks
					I	H			
AUT	ISWT-PDI-AUT1/0/0/1,2	AUTO	0803305	exam 7-8	X	-	N/A	N/A	Examination no's 1-8.
AUT	ISWT-PDI-AUT1/0/0/1,2	AUT55	0803301,0803302	exam 7-8	X	-	N/A	N/A	AUTO for thickness measurement only.
AUT	ISWT-PDI-AUT1/0/0/1,2	AUTSLIC40	0803303,0803304	exam 7-8	X	-	N/A	N/A	
AUT	ISWT-PDI-AUT1/0/0/1,2	AUT55T	0800301,0800302	exam 1-6	X	-	N/A	N/A	
AUT	ISWT-PDI-AUT1/0/0/1,2	AUTSLIC40T	0800303,0800304	exam 1-6	X	-	N/A	N/A	
AUT	ISWT-PDI-AUT1/0/0/1,2	AUTO	0800305	exam 1-6	X	-	N/A	N/A	

- NOTES:
1. Weld RPV-L-2-338A was examined from the inside surface using AIRIS-21 and EDAS-II examination equipment.
 2. No recordable indications were detected during this examination.
 3. The examination was limited due to proximity of baffle plate and baffle plate gusset, 73% examination coverage was achieved.

****UT CALIBRATION BLOCK(S)****
 D-70187-2/D70389-1

Page 33/140

Prepared by: Steven J. Todd
 Steven J. Todd - Project Engineer

Date: 4/30/05

AWES Calibration File



IHI SOUTHWEST TECHNOLOGIES AUTOMATED ULTRASONIC EXAMINATION RECORD

Site/Plant: Pilgrim Nuclear Station	Weld Identification: RPV-L-2-338A	Pro/Rev/Chg/ICN: ISWT-PDI-AUT1/0/0/1,2	Examination No.: ID-1
Project No.: 02-0285	Weld Description: Ring 1 Vert @ 78°	Device Configuration: D-PNPS-102	
Mod.Conf.: A-07B	Scan Path Drawing: SPLONGSH1&4DS	Exam Date: 24 Apr. 04	Examination Time: Start: N/A, End: N/A
Data Acquisition Operator (s) / SNT Level: David Kleinjan / II Alan Schaefer / N/A			Surface Temperature °F: Start: N/A, End: N/A

Data Acquisition

Scan Controller Parameters		Increment Axis/Arm	Planned	Actual	Scan Axis/Device	Planned	Actual	Positional Parameters	
Controller:	ID Device	Lower Limit	14766	N/A	Lower Limit	9838	N/A	Beam Direction:	Dn/Up
Scan:	Y Axis	Upper Limit	16026	N/A	Upper Limit	12466	N/A	Transducer Size:	1.00
Increment:	X Axis	Increment Interval	90		DCI	4		Code % of Overlap:	10
Mode:	Automatic Scan	Conversion Counts	100		Conversion Counts	100		Number of Scans:	15
Scan Motion:	Bi-directional	Conversion Units In.	1.00		Conversion Units In.	1.00		Device Position:	D (0)
Correction:	Default	EDAS Radius In.	113.10						

Module Parameters: A-07B Cal 03						Calibration Records:	Examination Notes:
Status	Angle	Direction	Scan Offset	Step Offset		PNS-03	Check for limitations due to the proximity of the jet pump diffuser and the baffle plate.
Channel 1	On	55	(-)	- 1.40(in)	- 1.21(in)	0800301	
Channel 2	On	55	(+)	+ 1.40(in)	- 1.21(in)	0800302	
Channel 3	On	SLIC-40	(-)	- 1.97(in)	+ 1.69(in)	0800303	
Channel 4	On	SLIC-40	(+)	+ 1.97(in)	+ 1.69(in)	0800304	Examination Remarks:
Channel 5	On	0T	(+)	+ 0.00(in)	+ 1.69(in)	0800305	Entergy/Pilgrim Procedure TP04-020
Channel 6	Off	N/A	N/A	N/A	N/A	N/A	
Channel 7	Off	N/A	N/A	N/A	N/A	N/A	NO EXAM DUE TO VESSEL TO BAFFLE PLATE GUSSET
Channel 8	Off	N/A	N/A	N/A	N/A	N/A	

Data Analysis

Increment & Scan Positions Actual					Recordable Indications			Analyst Remarks	
Scan No.(s)	Increment Position		Scan Position		Yes	No	N/A	Attachment:	
	Start	Stop	Start	Stop				<input type="checkbox"/> Yes <input checked="" type="checkbox"/> No	
N/A	N/A	N/A	N/A	N/A	Channel 1	<input type="checkbox"/>	<input type="checkbox"/>	<input checked="" type="checkbox"/>	
					Channel 2	<input type="checkbox"/>	<input type="checkbox"/>	<input checked="" type="checkbox"/>	Further Evaluation
					Channel 3	<input type="checkbox"/>	<input type="checkbox"/>	<input checked="" type="checkbox"/>	Required:
					Channel 4	<input type="checkbox"/>	<input type="checkbox"/>	<input checked="" type="checkbox"/>	<input type="checkbox"/> Yes <input checked="" type="checkbox"/> No
					Channel 5	<input type="checkbox"/>	<input type="checkbox"/>	<input checked="" type="checkbox"/>	Archive Tape/CD No.:
					Channel 6	<input type="checkbox"/>	<input type="checkbox"/>	<input checked="" type="checkbox"/>	N/A
					Channel 7	<input type="checkbox"/>	<input type="checkbox"/>	<input checked="" type="checkbox"/>	Analysis Tape/CD No.:
					Channel 8	<input type="checkbox"/>	<input type="checkbox"/>	<input checked="" type="checkbox"/>	N/A

Analyst / SNT Level / Date: Joel G. Godwin / III / 24 Apr. 05 *Joel G. Godwin*

Page 34/240



IHI SOUTHWEST TECHNOLOGIES AUTOMATED ULTRASONIC EXAMINATION RECORD

Site/Plant : Pilgrim Nuclear Station	Weld Identification: RPV-L-2-338A	Pro/Rev/Chg/ICN: ISwT-PDI-AUT1/0/0/1,2	Examination No.: ID-2
Project No.: 02-0285	Weld Description: Ring 1 Vert @ 78°	Device Configuration: D-PNPS-102	
Mod.Conf.: A-07B	Scan Path Drawing: SPLONGSH1&4DS	Exam Date: 24 Apr. 04	Examination Time: Start 1453, End 1501
Data Acquisition Operator (s) / SNT Level: David Kleinjan / II Alan Schaefer / N/A			Surface Temperature °F: Start 85, End 85

Scan Controller Parameters		Increment Axis/Arm	Planned	Actual	Scan Axis/Device	Planned	Actual	Positional Parameters	
Controller:	ID Device	Lower Limit	14766	14673	Lower Limit	12413	13781	Beam Direction:	Dn/Up
Scan:	Y Axis	Upper Limit	16026	15948	Upper Limit	15041	15041	Transducer Size:	1.00
Increment:	X Axis	Increment Interval	90		DCI	4		Code % of Overlap:	10
Mode:	Automatic Scan	Conversion Counts	100		Conversion Counts	100		Number of Scans:	15
Scan Motion:	Bi-directional	Conversion Units In.	1.00		Conversion Units In.	1.00		Device Position:	D (0)
Correction:	Default	EDAS Radius In.	113.10						

Module Parameters:						Calibration Records:	Examination Notes:
Status	Angle	Direction	Scan Offset	Step Offset			
Channel 1	On	55	(-)	- 1.40(in)	- 1.21(in)	PNS-03	Check for limitations due to the proximity of the jet pump diffuser and the baffle plate.
Channel 2	On	55	(+)	+ 1.40(in)	- 1.21(in)	0800301	
Channel 3	On	SLIC-40	(-)	- 1.97(in)	+ 1.69(in)	0800302	
Channel 4	On	SLIC-40	(+)	+ 1.97(in)	+ 1.69(in)	0800303	
Channel 5	On	0T	(+)	+ 0.00(in)	+ 1.69(in)	0800304	Examination Remarks:
Channel 6	Off	N/A	N/A	N/A	N/A	0800305	Entergy/Pilgrim Procedure TP04-020
Channel 7	Off	N/A	N/A	N/A	N/A	N/A	Limited examination due to vessel to baffle plate gusset.
Channel 8	Off	N/A	N/A	N/A	N/A	N/A	

Scan No.(s)	Increment & Scan Positions Actual				Recordable Indications			Analyst Remarks	
	Increment Position		Scan Position		Yes	No	N/A	Attachment: <input type="checkbox"/> Yes <input checked="" type="checkbox"/> No	
	Start	Stop	Start	Stop					
1 - 15	14673	15948	13781	15041	Channel 1 <input type="checkbox"/>	Channel 2 <input checked="" type="checkbox"/>	Channel 3 <input type="checkbox"/>	Further Evaluation Required: <input type="checkbox"/> Yes <input checked="" type="checkbox"/> No Archive Tape/CD No.: IA & IB Analysis Tape/CD No.: A & B	
				Channel 4 <input type="checkbox"/>	Channel 5 <input type="checkbox"/>	Channel 6 <input checked="" type="checkbox"/>	Channel 7 <input type="checkbox"/>		
				Channel 8 <input type="checkbox"/>					

Analyst / SNT Level / Date: Joel G. Godwin / III / 24 Apr. 05 *Joel A. Godwin*

Page 35/140



IHI SOUTHWEST TECHNOLOGIES AUTOMATED ULTRASONIC EXAMINATION RECORD

Site/Plant: Pilgrim Nuclear Station	Weld Identification: RPV-L-2-338A	Pro/Rev/Chg/ICN: ISwT-PDI-AUT1/0/0/1,2	Examination No.: ID-3
Project No.: 02-0285	Weld Description: Ring 1 Vert @ 78°	Device Configuration: D-PNPS-102	
Mod.Conf.: A-07B	Scan Path Drawing: SPLONGSH1&4DS	Exam Date: 24 Apr. 04	Surface Temperature °F
Data Acquisition Operator (s) / SNT Level: David Kleinjan / II Alan Schaefer / N/A			

Scan Controller Parameters		Increment Axis/Arm	Planned	Actual	Scan Axis/Device	Planned	Actual	Positional Parameters	
Controller:	ID Device	Lower Limit	14766	14746	Lower Limit	14988	14988	Beam Direction:	Dn/Up
Scan:	Y Axis	Upper Limit	16026	16021	Upper Limit	17616	17616	Transducer Size:	1.00
Increment:	X Axis	Increment Interval	90		DCI	4		Code % of Overlap:	10
Mode:	Automatic Scan	Conversion Counts	100		Conversion Counts	100		Number of Scans:	15
Scan Motion:	Bi-directional	Conversion Units In.	1.00		Conversion Units In.	1.00		Device Position:	D (0)
Correction:	Default	EDAS Radius In.	113.10						

Module Parameters: A-07B Cal 03						Calibration Records:	Examination Notes:
Status	Angle	Direction	Scan Offset	Step Offset		PNS-03	
Channel 1	On	55	(-)	- 1.40(in)	- 1.21(in)	0800301	Check for limitations due to the proximity of the jet pump diffuser and the baffle plate.
Channel 2	On	55	(+)	+ 1.40(in)	- 1.21(in)	0800302	
Channel 3	On	SLIC-40	(-)	- 1.97(in)	+ 1.69(in)	0800303	
Channel 4	On	SLIC-40	(+)	+ 1.97(in)	+ 1.69(in)	0800304	Examination Remarks: Entergy/Pilgrim Procedure TP04-020
Channel 5	On	0T	(+)	+ 0.00(in)	+ 1.69(in)	0800305	
Channel 6	Off	N/A	N/A	N/A	N/A	N/A	
Channel 7	Off	N/A	N/A	N/A	N/A	N/A	
Channel 8	Off	N/A	N/A	N/A	N/A	N/A	

Scan No.(s)	Increment & Scan Positions Actual				Recordable Indications			Attachment: <input type="checkbox"/> Yes <input checked="" type="checkbox"/> No Further Evaluation Required: <input type="checkbox"/> Yes <input checked="" type="checkbox"/> No Archive Tape/CD No.: 1A & 1B Analysis Tape/CD No.: A & B	Analyst Remarks
	Increment Position		Scan Position		Yes	No	N/A		
	Start	Stop	Start	Stop					
1 - 15	14747	16021	14988	17616	Channel 1 <input type="checkbox"/>	<input checked="" type="checkbox"/>	<input type="checkbox"/>		
					Channel 2 <input type="checkbox"/>	<input checked="" type="checkbox"/>	<input type="checkbox"/>		
					Channel 3 <input type="checkbox"/>	<input checked="" type="checkbox"/>	<input type="checkbox"/>		
					Channel 4 <input type="checkbox"/>	<input checked="" type="checkbox"/>	<input type="checkbox"/>		
					Channel 5 <input type="checkbox"/>	<input type="checkbox"/>	<input checked="" type="checkbox"/>		
					Channel 6 <input type="checkbox"/>	<input type="checkbox"/>	<input checked="" type="checkbox"/>		
					Channel 7 <input type="checkbox"/>	<input type="checkbox"/>	<input checked="" type="checkbox"/>		
					Channel 8 <input type="checkbox"/>	<input type="checkbox"/>	<input checked="" type="checkbox"/>		

Analyst / SNT Level / Date: Joel G. Godwin / III / 24 Apr. 05 *Joel G. Godwin*

Page 36/40



IH SOUTHWEST TECHNOLOGIES AUTOMATED ULTRASONIC EXAMINATION RECORD

Site/Plant : Pilgrim Nuclear Station	Weld Identification: RPV-L-2-338A	Pro/Rev/Chg/ICN: ISWT-PDI-AUT1/0/0/1,2	Examination No.: ID-4
Project No.: 02-0285	Weld Description: Ring 1 Vert @ 78°	Device Configuration: D-PNPS-102	
Mod.Conf.: A-07A	Scan Path Drawing: SPLONGSH1&4DS	Exam Date	Examination Time
Data Acquisition Operator (s) / SNT Level: Alan Schaefer / N/A		24 Apr. 04	Start End
		1528	1536
		Start	End
		85	85

Data Acquisition

Scan Controller Parameters		Increment Axis/Arm	Planned	Actual	Scan Axis/Device	Planned	Actual	Positional Parameters	
Controller:	ID Device	Lower Limit	14766	14749	Lower Limit	17563	17563	Beam Direction:	Up/Dn
Scan:	Y Axis	Upper Limit	16026	16021	Upper Limit	20191	20191	Transducer Size:	1.00
Increment:	X Axis	Increment Interval	90		DCI	4		Code % of Overlap:	10
Mode:	Automatic Scan	Conversion Counts	100		Conversion Counts	100		Number of Scans:	15
Scan Motion:	Bi-directional	Conversion Units In.	1.00		Conversion Units In.	1.00		Device Position:	D (180)
Correction:	Default	EDAS Radius In.	113.10						

Module Parameters: A-07A Cal 03						Calibration Records:	Examination Notes:
Status	Angle	Direction	Scan Offset	Step Offset		PNS-03	Check for limitations due to the proximity of the jet pump diffuser and the baffle plate.
Channel 1	On	55	(+)	+ 1.40(in)	+ 1.21(in)	0800301	
Channel 2	On	55	(-)	- 1.40(in)	+ 1.21(in)	0800302	
Channel 3	On	SLIC-40	(+)	+ 1.97(in)	- 1.69(in)	0800303	
Channel 4	On	SLIC-40	(-)	- 1.97(in)	- 1.69(in)	0800304	Examination Remarks: Entergy/Pilgrim Procedure TP04-020
Channel 5	On	0T	(+)	+ 0.00(in)	- 1.69(in)	0800305	
Channel 6	Off	N/A	N/A	N/A	N/A	N/A	
Channel 7	Off	N/A	N/A	N/A	N/A	N/A	
Channel 8	Off	N/A	N/A	N/A	N/A	N/A	

Data Analysis

Scan No.(s)	Increment & Scan Positions Actual				Recordable Indications			Attachment: <input type="checkbox"/> Yes <input checked="" type="checkbox"/> No	Analyst Remarks
	Increment Position		Scan Position		Yes	No	N/A		
1 - 15	Start	Stop	Start	Stop	Channel 1	<input type="checkbox"/>	<input checked="" type="checkbox"/>	<input type="checkbox"/>	Further Evaluation Required: <input type="checkbox"/> Yes <input checked="" type="checkbox"/> No Archive Tape/CD No.: 1A & 1B Analysis Tape/CD No.: A & B
	14749	16021	17563	20191	Channel 2	<input type="checkbox"/>	<input checked="" type="checkbox"/>	<input type="checkbox"/>	
					Channel 3	<input type="checkbox"/>	<input checked="" type="checkbox"/>	<input type="checkbox"/>	
					Channel 4	<input type="checkbox"/>	<input checked="" type="checkbox"/>	<input type="checkbox"/>	
					Channel 5	<input type="checkbox"/>	<input type="checkbox"/>	<input checked="" type="checkbox"/>	
					Channel 6	<input type="checkbox"/>	<input type="checkbox"/>	<input checked="" type="checkbox"/>	
					Channel 7	<input type="checkbox"/>	<input type="checkbox"/>	<input checked="" type="checkbox"/>	
					Channel 8	<input type="checkbox"/>	<input type="checkbox"/>	<input checked="" type="checkbox"/>	

Analyst / SNT Level / Date:

Joel G. Godwin / III / 24 Apr. 05

Joel A. Godwin

Page 37/140



IHI SOUTHWEST TECHNOLOGIES AUTOMATED ULTRASONIC EXAMINATION RECORD

Site/Plant : Pilgrim Nuclear Station	Weld Identification: RPV-L-2-338A	Pro/Rev/Chg/ICN: ISWT-PDI-AUT1/0/0/1,2	Examination No.: ID-5
Project No.: 02-0285	Weld Description: Ring 1 Vert @ 78°	Device Configuration: D-PNPS-102	
Mod.Conf.: A-07A	Scan Path Drawing: SPLONGSH1&4DS	Exam Date: 24 Apr. 04	Examination Time: Start 1547, End 1552
Data Acquisition Operator (s) / SNT Level: Alan Schaefer / N/A			Surface Temperature °F: Start 85, End 85

Scan Controller Parameters		Increment Axis/Arm		Planned	Actual	Scan Axis/Device		Planned	Actual	Positional Parameters	
Controller:	ID Device	Lower Limit	14766	14766	14748	Lower Limit	20138	20138	20138	Beam Direction:	Up/Dn
Scan:	Y Axis	Upper Limit	16026	16013	16013	Upper Limit	22766	22766	22766	Transducer Size:	1.00
Increment:	X Axis	Increment Interval	90			DCI	4			Code % of Overlap:	10
Mode:	Automatic Scan	Conversion Counts	100			Conversion Counts	100			Number of Scans:	15
Scan Motion:	Bi-directional	Conversion Units In.	1.00			Conversion Units In.	1.00			Device Position:	D (180)
Correction:	Default	EDAS Radius In.	113.10								

Module Parameters:						Calibration Records:		Examination Notes:	
Status	A-07A Angle	Cal 03 Direction	Scan Offset	Step Offset					
Channel 1	On	55 (+)	+ 1.40(in)	+ 1.21(in)	0800301			Check for limitations due to the proximity of the jet pump diffuser and the baffle plate.	
Channel 2	On	55 (-)	- 1.40(in)	+ 1.21(in)	0800302				
Channel 3	On	SLIC-40 (+)	+ 1.97(in)	- 1.69(in)	0800303				
Channel 4	On	SLIC-40 (-)	- 1.97(in)	- 1.69(in)	0800304			Examination Remarks:	
Channel 5	On	0T (+)	+ 0.00(in)	- 1.69(in)	0800305			Entergy/Pilgrim Procedure TP04-020	
Channel 6	Off	N/A	N/A	N/A	N/A				
Channel 7	Off	N/A	N/A	N/A	N/A				
Channel 8	Off	N/A	N/A	N/A	N/A				

Scan No.(s)	Increment & Scan Positions Actual				Recordable Indications			Attachment:		Analyst Remarks
	Start	Stop	Start	Stop	Yes	No	N/A	<input type="checkbox"/> Yes <input checked="" type="checkbox"/> No		
1 - 15	14748	16012	20138	22766	Channel 1 <input type="checkbox"/> Yes <input checked="" type="checkbox"/> No <input type="checkbox"/> N/A			<input type="checkbox"/> Yes <input checked="" type="checkbox"/> No		
					Channel 2 <input type="checkbox"/> Yes <input checked="" type="checkbox"/> No <input type="checkbox"/> N/A			Further Evaluation Required:		
					Channel 3 <input type="checkbox"/> Yes <input checked="" type="checkbox"/> No <input type="checkbox"/> N/A			<input type="checkbox"/> Yes <input checked="" type="checkbox"/> No		
					Channel 4 <input type="checkbox"/> Yes <input checked="" type="checkbox"/> No <input type="checkbox"/> N/A			Archive Tape/CD No.:		
					Channel 5 <input type="checkbox"/> Yes <input type="checkbox"/> No <input checked="" type="checkbox"/> N/A			1A & 1B		
					Channel 6 <input type="checkbox"/> Yes <input type="checkbox"/> No <input checked="" type="checkbox"/> N/A			Analysis Tape/CD No.:		
					Channel 7 <input type="checkbox"/> Yes <input type="checkbox"/> No <input checked="" type="checkbox"/> N/A			A & B		
					Channel 8 <input type="checkbox"/> Yes <input type="checkbox"/> No <input checked="" type="checkbox"/> N/A					

Analyst / SNT Level / Date:

Joel G. Godwin / III / 24 Apr. 05

Joel G. Godwin

Page 38/140



IHI SOUTHWEST TECHNOLOGIES AUTOMATED ULTRASONIC EXAMINATION RECORD

Site/Plant : Pilgrim Nuclear Station	Weld Identification: RPV-L-2-338A	Pro/Rev/Chg/ICN: ISwT-PDI-AUT1/0/0/1,2	Examination No.: ID-6
Project No.: 02-0285	Weld Description: Ring 1 Vert @ 78°	Device Configuration: D-PNPS-102	Surface Temperature °F
Mod.Conf.: A-07A	Scan Path Drawing: SPLONGSH1&4DS	Exam Date	Examination Time
Data Acquisition Operator (s) / SNT Level: Alan Schaefer / N/A		24 Apr. 04	Start End
			Start End
			85 85

Data Acquisition

Scan Controller Parameters		Increment Axis/Arm	Planned	Actual	Scan Axis/Device	Planned	Actual	Positional Parameters	
Controller:	ID Device	Lower Limit	14766	14750	Lower Limit	22713	22713	Beam Direction:	Up/Dn
Scan:	Y Axis	Upper Limit	16026	16033	Upper Limit	25341	25341	Transducer Size:	1.00
Increment:	X Axis	Increment Interval	90		DCI	4		Code % of Overlap:	10
Mode:	Automatic Scan	Conversion Counts	100		Conversion Counts	100		Number of Scans:	15
Scan Motion:	Bi-directional	Conversion Units In.	1.00		Conversion Units In.	1.00		Device Position:	D (180)
Correction:	Default	EDAS Radius In.	113.10						

Module Parameters: A-07A Cal 03						Calibration Records:	Examination Notes:
Status	Angle	Direction	Scan Offset	Step Offset		PNS-03	
Channel 1	On	55	(+)	+ 1.40(in)	+ 1.21(in)	0800301	Check for limitations due to the proximity of the jet pump diffuser and the baffle plate.
Channel 2	On	55	(-)	- 1.40(in)	+ 1.21(in)	0800302	
Channel 3	On	SLIC-40	(+)	+ 1.97(in)	- 1.69(in)	0800303	
Channel 4	On	SLIC-40	(-)	- 1.97(in)	- 1.69(in)	0800304	Examination Remarks: Entergy/Pilgrim Procedure TP04-020
Channel 5	On	0T	(+)	+ 0.00(in)	- 1.69(in)	0800305	
Channel 6	Off	N/A	N/A	N/A	N/A	N/A	
Channel 7	Off	N/A	N/A	N/A	N/A	N/A	
Channel 8	Off	N/A	N/A	N/A	N/A	N/A	

Data Analysis

Increment & Scan Positions Actual					Recordable Indications			Analyst Remarks	
Scan No.(s)	Increment Position		Scan Position		Yes	No	N/A	Attachment:	
	Start	Stop	Start	Stop				<input type="checkbox"/> Yes <input checked="" type="checkbox"/> No	
1 - 15	14750	16034	22713	25341	Channel 1 <input type="checkbox"/>	<input checked="" type="checkbox"/>	<input type="checkbox"/>	Further Evaluation Required: <input type="checkbox"/> Yes <input checked="" type="checkbox"/> No Archive Tape/CD No.: 1A & 1B Analysis Tape/CD No.: A & B	
					Channel 2 <input type="checkbox"/>	<input checked="" type="checkbox"/>	<input type="checkbox"/>		
					Channel 3 <input type="checkbox"/>	<input checked="" type="checkbox"/>	<input type="checkbox"/>		
					Channel 4 <input type="checkbox"/>	<input checked="" type="checkbox"/>	<input type="checkbox"/>		
					Channel 5 <input type="checkbox"/>	<input type="checkbox"/>	<input checked="" type="checkbox"/>		
					Channel 6 <input type="checkbox"/>	<input type="checkbox"/>	<input checked="" type="checkbox"/>		
					Channel 7 <input type="checkbox"/>	<input type="checkbox"/>	<input checked="" type="checkbox"/>		
					Channel 8 <input type="checkbox"/>	<input type="checkbox"/>	<input checked="" type="checkbox"/>		

Analyst / SNT Level / Date: Joel G. Godwin / III / 24 Apr. 05 *Joel G. Godwin*

Boop 39/240



IH SOUTHWEST TECHNOLOGIES AUTOMATED ULTRASONIC EXAMINATION RECORD

Site/Plant : Pilgrim Nuclear Station	Weld Identification: RPV-L-2-338A	Pro/Rev/Chg/ICN: ISWT-PDI-AUT1/0/0/1,2	Examination No.: ID-7
Project No.: 02-0285	Weld Description: Ring 1 Vert @ 78°	Device Configuration: D-PNPS-101	
Mod.Conf.: A-07-1D	Scan Path Drawing: SPLONGSH1&4DS	Exam Date: 24 Apr. 05	Surface Temperature °F
Data Acquisition Operator(s) / SNT Level: Richard Riddles / II		Examination Time	Start End
		2228 2240	80 80

Data Acquisition

Scan Controller Parameters		Increment Axis/Device		Planned	Actual	Scan Axis/Arm	Planned	Actual	Positional Parameters	
Controller:	ID Device	Lower Limit	10488	14718	14718	Lower Limit	14646	14646	Beam Direction:	Ccw/Cw
Scan:	X Axis	Upper Limit	17508	17508	17508	Upper Limit	16146	16146	Transducer Size:	1.00
Increment:	Y Axis	Increment Interval	90			DCI	4		Code % of Overlap:	10
Mode:	Automatic Scan	Conversion Counts	100			Conversion Counts	100		Number of Scans:	79
Scan Motion:	Bi-directional	Conversion Units In.	1.00			Conversion Units In.	1.00		Device Position:	A (0)
Correction:	Default	EDAS Radius In.	113.10							

Module Parameters: A-07-1D Cal 33						Calibration Records:	Examination Notes:
Status	Angle	Direction	Scan Offset	Step Offset			
Channel 1	On	55	(-)	+ 7.00(in)	+ 0.00(in)	PNS-33	Check for limitations due to the proximity of the jet pump diffuser and the baffle plate.
Channel 2	On	55	(+)	- 7.00(in)	+ 0.00(in)	0803301	
Channel 3	On	SLIC-40	(-)	+ 4.40(in)	+ 1.00(in)	0803302	
Channel 4	On	SLIC-40	(+)	- 4.40(in)	- 1.00(in)	0803303	
Channel 5	On	0T	(+)	+ 4.40(in)	- 1.00(in)	0803304	Examination Remarks:
Channel 6	Off	N/A	N/A	N/A	N/A	0803305	Entergy/Pilgrim Procedure TP04-020
Channel 7	Off	N/A	N/A	N/A	N/A	N/A	Limited exam due to vessel baffle plate gusset.
Channel 8	Off	N/A	N/A	N/A	N/A	N/A	

Data Analysis

Increment & Scan Positions Actual				Recordable Indications			Analyst Remarks	
Scan No.(s)	Increment Position		Scan Position		Yes	No	N/A	Attachment: <input type="checkbox"/> Yes <input checked="" type="checkbox"/> No
	Start	Stop	Start	Stop				
48 - 80	14707	17508	14646	16146	Channel 1 <input type="checkbox"/>	Channel 2 <input checked="" type="checkbox"/>	Channel 3 <input type="checkbox"/>	Further Evaluation Required: <input type="checkbox"/> Yes <input checked="" type="checkbox"/> No Archive Tape/CD No.: 1A & IB Analysis Tape/CD No.: A & B
					Channel 4 <input type="checkbox"/>	Channel 5 <input type="checkbox"/>	Channel 6 <input checked="" type="checkbox"/>	
					Channel 7 <input type="checkbox"/>	Channel 8 <input type="checkbox"/>	Channel 8 <input checked="" type="checkbox"/>	

Analyst / SNT Level / Date: Joel G. Godwin / III / 25 Apr. 05 *Joel G. Godwin*

Page 40/140



IHI SOUTHWEST TECHNOLOGIES AUTOMATED ULTRASONIC EXAMINATION RECORD

Site/Plant : Pilgrim Nuclear Station	Weld Identification: RPV-L-2-338A	Pro/Rev/Chg/ICN: ISWT-PDI-AUT1/0/0/1,2	Examination No.: ID-8
Project No.: 02-0285	Weld Description: Ring 1 Vert @ 78°	Device Configuration: D-PNPS-101	
Mod.Conf.: A-07-1D	Scan Path Drawing: SPLONGSHI&4DS	Exam Date: 24 Apr. 05	Surface Temperature °F
Data Acquisition Operator (s) / SNT Level: Richard Riddles / II		Examination Time	
		Start: 2345	End: 0011
		Start: 80	End: 80

Data Acquisition

Scan Controller Parameters		Increment Axis/Device		Planned	Actual	Scan Axis/Arm		Planned	Actual	Positional Parameters	
Controller:	ID Device	Lower Limit	17418	17418	17418	Lower Limit	14646	14646	14646	Beam Direction:	CCW/CW
Scan:	X Axis	Upper Limit	24438	24438	24438	Upper Limit	16146	16146	16146	Transducer Size:	1.00
Increment:	Y Axis	Increment Interval	90			DCI	4			Code % of Overlap:	10
Mode:	Automatic Scan	Conversion Counts	100			Conversion Counts	100			Number of Scans:	79
Scan Motion:	Bi-directional	Conversion Units In.	1.00			Conversion Units In.	1.00			Device Position:	A (0)
Correction:	Default	EDAS Radius In.	113.10								

Module Parameters:						Calibration Records:		Examination Notes:	
A-07-1D		Cal 33				PNS-33		Check for limitations due to the proximity of the jet pump diffuser and the baffle plate.	
Status	Angle	Direction	Scan Offset	Step Offset					
Channel 1	On	55	(-)	+ 7.00(in)	+ 0.00(in)	0803301			
Channel 2	On	55	(+)	- 7.00(in)	+ 0.00(in)	0803302			
Channel 3	On	SLIC-40	(-)	+ 4.40(in)	+ 1.00(in)	0803303			
Channel 4	On	SLIC-40	(+)	- 4.40(in)	- 1.00(in)	0803304	Examination Remarks: Energy/Pilgrim Procedure TP04-020		
Channel 5	On	0T	(+)	+ 4.40(in)	- 1.00(in)	0803305			
Channel 6	Off	N/A	N/A	N/A	N/A	N/A			
Channel 7	Off	N/A	N/A	N/A	N/A	N/A			
Channel 8	Off	N/A	N/A	N/A	N/A	N/A			

Increment & Scan Positions Actual					Recordable Indications			Attachment:		Analyst Remarks
Scan No.(s)	Increment Position		Scan Position		Yes	No	N/A	<input type="checkbox"/> Yes <input checked="" type="checkbox"/> No		
	Start	Stop	Start	Stop				Further Evaluation Required:		
1 - 79	17418	24438	14646	16146	<input type="checkbox"/>	<input checked="" type="checkbox"/>	<input type="checkbox"/>	<input type="checkbox"/> Yes <input checked="" type="checkbox"/> No		
					<input type="checkbox"/>	<input checked="" type="checkbox"/>	<input type="checkbox"/>	<input type="checkbox"/> Yes <input checked="" type="checkbox"/> No		
					<input type="checkbox"/>	<input type="checkbox"/>	<input checked="" type="checkbox"/>	Archive Tape/CD No.:		
					<input type="checkbox"/>	<input type="checkbox"/>	<input checked="" type="checkbox"/>	1A & 1B		
					<input type="checkbox"/>	<input type="checkbox"/>	<input checked="" type="checkbox"/>	Analysis Tape/CD No.:		
					<input type="checkbox"/>	<input type="checkbox"/>	<input checked="" type="checkbox"/>	A & B		

Analyst / SNT Level / Date: Joel G. Godwin / III / 25 Apr. 05 *Paul A. Godwin*

Page 41/44

ISWT EXAMINATION SUMMARY RECORD

Project No.: 02-0285

PILGRIM STATION

Summary Sheet No.: 000300

SITE: PILGRIM STATION
SYSTEM: REACTOR PRESSURE VESSEL
LINE/SUBASSEMBLY: RING 1 VERTICAL WELD @ 318-DEGREES
IDENTIFICATION: RPV-L-2-338C

NDE Method	Proc/Rev/Chg/ICN	NDE Examination	Calibration Sheet No.	Data Sheet No.	N O R T I H	Resolution Record	CNF Number	Remarks
AUT	ISWT-PDI-AUT1/0/0/1,2	AUT45	0803401	exam 18	X -	N/A	N/A	Examination no's 17 - 18.
AUT	ISWT-PDI-AUT1/0/0/1,2	AUT55	0803402	exam 18	X -	N/A	N/A	AUTO for thickness measurement only.
AUT	ISWT-PDI-AUT1/0/0/1,2	AUTSLIC40	0803403,0803404	exam 18	X -	N/A	N/A	
AUT	ISWT-PDI-AUT1/0/0/1,2	AUTSLIC40	0803405	exam 18	X -	N/A	N/A	
AUT	ISWT-PDI-AUT1/0/0/1,2	AUT55T	0802305,0802302	exam 17	X -	N/A	N/A	
AUT	ISWT-PDI-AUT1/0/0/1,2	AUTSLIC40T	0802303,0802304	exam 17	X -	N/A	N/A	
AUT	ISWT-PDI-AUT1/0/0/1,2	AUTO	0802305	exam 17	X -	N/A	N/A	

- NOTES:
1. Weld RPV-L-2-338C was examined from the inside surface using AIRIS-21 and EDAS-II examination equipment.
 2. No recordable indications were detected during this examination.
 3. The examination was limited due to proximity of baffle plate, baffle plate gusset, jet pump diffusers, core shroud tie rod, and the N2K nozzle, 25% examination coverage was achieved.
 4. Examination 18 was divided into 3 segments 18a, 18b, and 18c.

****UT CALIBRATION BLOCK(S)****
 D-70187-2/D70389-1

Prepared by: Steven J. Todd
 Steven J. Todd - Project Engineer

Date: 4/30/05

Boqr 42/140



IHI SOUTHWEST TECHNOLOGIES AUTOMATED ULTRASONIC EXAMINATION RECORD

Site/Plant : Pilgrim Nuclear Station	Weld Identification: RPV-L-2-338C	Pro/Rev/Chg/ICN: ISwT-PDI-AUT1/0/0/1,2	Examination No.: ID-17a
Project No.: 02-0285	Weld Description: Ring 1 Vert @ 318°	Device Configuration: D-PNPS-101	
Mod.Conf.: A-07-1A	Scan Path Drawing: SPLONGSH1&4SS	Exam Date: 26 Apr. 05	Surface Temperature °F
Data Acquisition Operator (s) / SNT Level: Richard Riddles / II		Examination Time	Start End
		0255 0309	48 88

Data Acquisition

Scan Controller Parameters		Increment Axis/Device	Planned	Actual	Scan Axis/Arm	Planned	Actual	Positional Parameters	
Controller:	ID Device	Lower Limit	62139	62139	Lower Limit	9888	14050	Beam Direction:	Up/Dn
Scan:	Y Axis	Upper Limit	63399	62693	Upper Limit	25040	15550	Transducer Size:	1.00
Increment:	X Axis	Increment Interval	90		DCI	4		Code % of Overlap:	10
Mode:	Automatic Scan	Conversion Counts	100		Conversion Counts	100		Number of Scans:	15
Scan Motion:	Bi-directional	Conversion Units In.	1.00		Conversion Units In.	1.00		Device Position:	A (90)
Correction:	Default	EDAS Radius In.	113.10						

Module Parameters:						Cal 23	Calibration Records:	Examination Notes:
Status	A-07-1A Angle	Direction	Scan Offset	Step Offset				
Channel 1	On 55	(+)	- 7.00(in)	+ 0.00(in)		PNS-23	Check for limitations due to the proximity of the jet pump diffusers, the tie rod, the N2 nozzle, and the baffle plate.	
Channel 2	On 55	(-)	+ 7.00(in)	+ 0.00(in)		0802301		
Channel 3	On SLIC-40	(+)	- 4.40(in)	+ 1.00(in)		0802302		
Channel 4	On SLIC-40	(-)	+ 4.40(in)	- 1.00(in)		0802303		
Channel 5	On 0T	(+)	- 4.40(in)	- 1.00(in)		0802304	Examination Remarks:	
Channel 6	Off N/A	N/A	N/A	N/A		0802305	Energy/Pilgrim Procedure TP04-020	
Channel 7	Off N/A	N/A	N/A	N/A		N/A	Limited exam due to the proximity of the baffle plate.	
Channel 8	Off N/A	N/A	N/A	N/A		N/A		

Data Analysis

Scan No.(s)	Increment & Scan Positions Actual				Recordable Indications			Analyst Remarks	
	Increment Position		Scan Position		Yes	No	N/A	Attachment:	
1 - 8	Start	Stop	Start	Stop	Channel 1	<input type="checkbox"/>	<input checked="" type="checkbox"/>	<input type="checkbox"/>	<input type="checkbox"/> Yes <input checked="" type="checkbox"/> No
	62139	62693	14050	15550	Channel 2	<input type="checkbox"/>	<input checked="" type="checkbox"/>	<input type="checkbox"/>	Further Evaluation
					Channel 3	<input type="checkbox"/>	<input checked="" type="checkbox"/>	<input type="checkbox"/>	Required:
					Channel 4	<input type="checkbox"/>	<input checked="" type="checkbox"/>	<input type="checkbox"/>	<input type="checkbox"/> Yes <input checked="" type="checkbox"/> No
					Channel 5	<input type="checkbox"/>	<input type="checkbox"/>	<input checked="" type="checkbox"/>	Archive Tape/CD No.:
					Channel 6	<input type="checkbox"/>	<input type="checkbox"/>	<input checked="" type="checkbox"/>	2A & 2B
					Channel 7	<input type="checkbox"/>	<input type="checkbox"/>	<input checked="" type="checkbox"/>	Analysis Tape/CD No.:
					Channel 8	<input type="checkbox"/>	<input type="checkbox"/>	<input checked="" type="checkbox"/>	A & B

Analyst / SNT Level / Date: Joel G. Godwin / III / 26 Apr. 05 *Joel A. Godwin*

809 43/240



IH SOUTHWEST TECHNOLOGIES AUTOMATED ULTRASONIC EXAMINATION RECORD

Site/Plant : Pilgrim Nuclear Station	Weld Identification: RPV-L-2-338C	Pro/Rev/Chg/ICN: ISwT-PDI-AUT1/0/0/1,2	Examination No.: ID-18a
Project No.: 02-0285	Weld Description: Ring 1 Vert @ 318°	Device Configuration: D-PNPS-102	
Mod.Conf.: A-08D	Scan Path Drawing: SPLONGSH1&4SS	Exam Date	Examination Time
Data Acquisition Operator (s) / SNT Level: D. Kleinjan / II		25 Apr. 05	Surface Temperature °F
		Start	End
		1719	1810
		Start	End
		88	88

Data Acquisition

Scan Controller Parameters		Increment Axis/Arm	Planned	Actual	Scan Axis/Device	Planned	Actual	Positional Parameters	
Controller:	ID Device	Lower Limit	10419	13898	Lower Limit	62178	62178	Beam Direction:	Ccw
Scan:	X Axis	Upper Limit	24549	15657	Upper Limit	63986	63986	Transducer Size:	1.00
Increment:	Y Axis	Increment Interval	90		DCI	4		Code % of Overlap:	10
Mode:	Automatic Scan	Conversion Counts	100		Conversion Counts	100		Number of Scans:	158
Scan Motion:	Bi-directional	Conversion Units In.	1.00		Conversion Units In.	1.00		Device Position:	D (90)
Correction:	Default	EDAS Radius In.	113.10						

Module Parameters:						Calibration Records:		Examination Notes:	
	A-08D	Cal 34							
Channel	Status	Angle	Direction	Scan Offset	Step Offset				
Channel 1	On	45	(-)	- 1.40(in)	+ 1.21(in)	PNS-34		Check for limitations due to the proximity of the jet pump diffusers, the tie rod, the N2 nozzle, and the baffle plate.	
Channel 2	On	55	(-)	+ 1.40(in)	+ 1.21(in)	0803401			
Channel 3	On	SLIC-40	(-)	- 1.97(in)	- 1.69(in)	0803402			
Channel 4	On	SLIC-40	(-)	+ 1.97(in)	- 1.69(in)	0803403			
Channel 5	On	SLIC-40	(+)	+ 0.00(in)	- 1.69(in)	0803404		Examination Remarks:	
Channel 6	Off	N/A	N/A	N/A	N/A	0803405		Entergy/Pilgrim Procedure TP04-020	
Channel 7	Off	N/A	N/A	N/A	N/A	N/A		Limited exam due to the jet pump diffusers.	
Channel 8	Off	N/A	N/A	N/A	N/A	N/A			

Data Analysis

Scan No.(s)	Increment & Scan Positions Actual				Recordable Indications			Analyst Remarks	
	Increment Position		Scan Position		Yes	No	N/A		
	Start	Stop	Start	Stop	Channel 1	<input type="checkbox"/>	<input checked="" type="checkbox"/>	<input type="checkbox"/>	Attachment:
41 - 59	13898	15657	62178	63986	Channel 2	<input type="checkbox"/>	<input checked="" type="checkbox"/>	<input type="checkbox"/>	<input type="checkbox"/> Yes <input checked="" type="checkbox"/> No
					Channel 3	<input type="checkbox"/>	<input checked="" type="checkbox"/>	<input type="checkbox"/>	Further Evaluation
					Channel 4	<input type="checkbox"/>	<input checked="" type="checkbox"/>	<input type="checkbox"/>	Required:
					Channel 5	<input type="checkbox"/>	<input checked="" type="checkbox"/>	<input type="checkbox"/>	<input type="checkbox"/> Yes <input checked="" type="checkbox"/> No
					Channel 6	<input type="checkbox"/>	<input type="checkbox"/>	<input checked="" type="checkbox"/>	Archive Tape/CD No.:
					Channel 7	<input type="checkbox"/>	<input type="checkbox"/>	<input checked="" type="checkbox"/>	2A & 2B
					Channel 8	<input type="checkbox"/>	<input type="checkbox"/>	<input checked="" type="checkbox"/>	Analysis Tape/CD No.:
									A & B

Analyst / SNT Level / Date: Joel G. Godwin / III / 26 Apr. 05 *Joel G. Godwin*

Page 44/440



IHI SOUTHWEST TECHNOLOGIES AUTOMATED ULTRASONIC EXAMINATION RECORD

Site/Plant: Pilgrim Nuclear Station	Weld Identification: RPV-L-2-338C	Pro/Rev/Chg/ICN: ISwT-PDI-AUT1/0/0/1,2	Examination No.: ID-18b
Project No.: 02-0285	Weld Description: Ring 1 Vert @ 318°	Device Configuration: D-PNPS-102	
Mod.Conf.: A-08D	Scan Path Drawing: SPLONGSHI&4SS	Exam Date: 25 Apr. 05	Surface Temperature °F
Data Acquisition Operator (s) / SNT Level: D. Kleinjan / II		Examination Time	
		Start: 1819	End: 1855
		Start: 88	End: 88

Data Acquisition

Scan Controller Parameters		Increment Axis/Arm	Planned	Actual	Scan Axis/Device	Planned	Actual	Positional Parameters	
Controller:	ID Device	Lower Limit	10419	15728	Lower Limit	62178	62178	Beam Direction:	Ccw
Scan:	X Axis	Upper Limit	24549	19382	Upper Limit	63986	63986	Transducer Size:	1.00
Increment:	Y Axis	Increment Interval	90		DCI	4		Code % of Overlap:	10
Mode:	Automatic Scan	Conversion Counts	100		Conversion Counts	100		Number of Scans:	158
Scan Motion:	Bi-directional	Conversion Units In.	1.00		Conversion Units In.	1.00		Device Position:	D (90)
Correction:	Default	EDAS Radius In.	113.10						

Module Parameters:						Calibration Records:	Examination Notes:
Status	Angle	Direction	Scan Offset	Step Offset			
Channel 1	On	45	(-)	- 1.40(in)	+ 1.21(in)	PNS-34	Check for limitations due to the proximity of the jet pump diffusers, the tie rod, the N2 nozzle, and the baffle plate.
Channel 2	On	55	(-)	+ 1.40(in)	+ 1.21(in)	0803401	
Channel 3	On	SLIC-40	(-)	- 1.97(in)	- 1.69(in)	0803402	
Channel 4	On	SLIC-40	(-)	+ 1.97(in)	- 1.69(in)	0803403	
Channel 5	On	SLIC-40	(+)	+ 0.00(in)	- 1.69(in)	0803404	
Channel 6	Off	N/A	N/A	N/A	N/A	N/A	Examination Remarks: Entergy/Pilgrim Procedure TP04-020 Limited exam due to the N2K nozzle.
Channel 7	Off	N/A	N/A	N/A	N/A	N/A	
Channel 8	Off	N/A	N/A	N/A	N/A	N/A	

Data Analysis

Scan No.(s)	Increment & Scan Positions Actual				Recordable Indications			Attachment:	Analyst Remarks
	Start	Stop	Start	Stop	Yes	No	N/A		
60 - 100	15728	19382	62178	63986	Channel 1	<input type="checkbox"/>	<input checked="" type="checkbox"/>	<input type="checkbox"/>	Further Evaluation Required: <input type="checkbox"/> Yes <input checked="" type="checkbox"/> No Archive Tap/CD No.: 2A & 2B Analysis Tap/CD No.: A & B
					Channel 2	<input type="checkbox"/>	<input checked="" type="checkbox"/>	<input type="checkbox"/>	
					Channel 3	<input type="checkbox"/>	<input checked="" type="checkbox"/>	<input type="checkbox"/>	
					Channel 4	<input type="checkbox"/>	<input checked="" type="checkbox"/>	<input type="checkbox"/>	
					Channel 5	<input type="checkbox"/>	<input checked="" type="checkbox"/>	<input type="checkbox"/>	
					Channel 6	<input type="checkbox"/>	<input type="checkbox"/>	<input checked="" type="checkbox"/>	
					Channel 7	<input type="checkbox"/>	<input type="checkbox"/>	<input checked="" type="checkbox"/>	
					Channel 8	<input type="checkbox"/>	<input type="checkbox"/>	<input checked="" type="checkbox"/>	

Analyst / SNT Level / Date:

Joel G. Godwin / III / 26 Apr. 05

Joel G. Godwin

Page 45/40



IHI SOUTHWEST TECHNOLOGIES AUTOMATED ULTRASONIC EXAMINATION RECORD

Site/Plant : Pilgrim Nuclear Station	Weld Identification: RPV-L-2-338C	Pro/Rev/Chg/ICN: ISwT-PDI-AUT1/0/0/1,2	Examination No.: ID-18c
Project No.: 02-0285	Weld Description: Ring 1 Vert @ 318°	Device Configuration: D-PNPS-102	
Mod.Conf.: A-08D	Scan Path Drawing: SPLONGSH1&4SS	Exam Date: 25 Apr. 05	Surface Temperature °F:
Data Acquisition Operator (s) / SNT Level: Richard Riddles / II		Examination Time:	
		Start: 2051	End: 2145
		Start: 88	End: 88

Data Acquisition

Scan Controller Parameters		Increment Axis/Arm	Planned	Actual	Scan Axis/Device	Planned	Actual	Positional Parameters	
Controller:	ID Device	Lower Limit	10419	22029	Lower Limit	62178	62178	Beam Direction:	Ccw
Scan:	X Axis	Upper Limit	24549	23019	Upper Limit	63986	63986	Transducer Size:	1.00
Increment:	Y Axis	Increment Interval	90		DCI	4		Code % of Overlap:	10
Mode:	Automatic Scan	Conversion Counts	100		Conversion Counts	100		Number of Scans:	158
Scan Motion:	Bi-directional	Conversion Units In.	1.00		Conversion Units In.	1.00		Device Position:	D (90)
Correction:	Default	EDAS Radius In.	113.10						

Module Parameters:		A-08D	Cal 34			Calibration Records:	Examination Notes:
Status	Angle	Direction	Scan Offset	Step Offset			
Channel 1	On	45	(-)	- 1.40(in)	+ 1.21(in)	PNS-34	Check for limitations due to the proximity of the jet pump diffusers, the tie rod, the N2 nozzle, and the baffle plate.
Channel 2	On	55	(-)	+ 1.40(in)	+ 1.21(in)	0803401	
Channel 3	On	SLIC-40	(-)	- 1.97(in)	- 1.69(in)	0803402	
Channel 4	On	SLIC-40	(-)	+ 1.97(in)	- 1.69(in)	0803403	
Channel 5	On	SLIC-40	(+)	+ 0.00(in)	- 1.69(in)	0803404	Examination Remarks: Energy/Pilgrim Procedure TP04-020 Limited exam due to the N2K nozzle.
Channel 6	Off	N/A	N/A	N/A	N/A	0803405	
Channel 7	Off	N/A	N/A	N/A	N/A	N/A	
Channel 8	Off	N/A	N/A	N/A	N/A	N/A	

Data Analysis

Scan No.(s)	Increment & Scan Positions Actual				Recordable Indications			Attachment:	Analyst Remarks
	Start	Stop	Start	Stop	Yes	No	N/A		
130 - 141	21924	23019	62178	63986	Channel 1	<input type="checkbox"/>	<input checked="" type="checkbox"/>	<input type="checkbox"/>	Further Evaluation Required: <input type="checkbox"/> Yes <input checked="" type="checkbox"/> No Archive Tape/CD No.: 2A & 2B Analysis Tape/CD No.: A & B
				Channel 2	<input type="checkbox"/>	<input checked="" type="checkbox"/>	<input type="checkbox"/>		
				Channel 3	<input type="checkbox"/>	<input checked="" type="checkbox"/>	<input type="checkbox"/>		
				Channel 4	<input type="checkbox"/>	<input checked="" type="checkbox"/>	<input type="checkbox"/>		
				Channel 5	<input type="checkbox"/>	<input checked="" type="checkbox"/>	<input type="checkbox"/>		
				Channel 6	<input type="checkbox"/>	<input type="checkbox"/>	<input checked="" type="checkbox"/>		
				Channel 7	<input type="checkbox"/>	<input type="checkbox"/>	<input checked="" type="checkbox"/>		
				Channel 8	<input type="checkbox"/>	<input type="checkbox"/>	<input checked="" type="checkbox"/>		

Analyst / SNT Level / Date:

Joel G. Godwin / III / 26 Apr. 05

Paul S. Jordan

Page 46/140



IHI SOUTHWEST TECHNOLOGIES AUTOMATED ULTRASONIC EXAMINATION RECORD

Site/Plant: Pilgrim Station	Weld Identification: RPV-L-2-338B	Pro/Rev/Chg/ICN: ISWT-PDI-AUT1/0/0/1,2	Examination No.: ID-9
Project No.: 02-0285	Weld Description: Ring 1 Vert @ 198°	Device Configuration: D-PNPS-102	
Mod.Conf.: A-07B	Scan Path Drawing: SPLONGSH1&4DS	Exam Date: 1-May-03	Surface Temperature 9F
Data Acquisition Operator (s) / SNT Level: Harper Jacoby / N/A			Start: 87, End: 87

Scan Controller Parameters		Increment Axis/Arm	Planned	Actual	Scan Axis/Device	Planned	Actual	Positional Parameters	
Controller:	ID Device	Lower Limit	38452		Lower Limit	9838		Beam Direction:	Dn/Up
Scan:	Y Axis	Upper Limit	39712		Upper Limit	12466		Transducer Size:	1.00
Increment:	X Axis	Increment Interval	90		DCI	4		Cdr. % of Overlap:	10
Mode:	Automatic Scan	Conversion Counts	100		Conversion Counts	100		Number of Scans:	15
Scan Motion:	Bi-directional	Conversion Units In.	1.00		Conversion Units In.	1.00		Device Position:	D (0)
Correction:	Default	EDAS Radius In.	113.10						

Module Parameters: A-07B Cal 03						Calibration Records:	Examination Notes:
Channel	Status	Angle	Direction	Scan Offset	Step Offset		
Channel 1	On	55	(-)	- 1.40(in)	- 1.21(in)	PNS-03	Check for limitations due to the proximity of the jet pump diffuser, the N1 nozzle, and the baffle plate.
Channel 2	On	55	(+)	+ 1.40(in)	- 1.21(in)	80031	
Channel 3	On	SLIC-40	(-)	- 1.97(in)	+ 1.69(in)	80032	Examination Remarks: No exam due to proximity of baffel plate gusset.
Channel 4	On	SLIC-40	(+)	+ 1.97(in)	+ 1.69(in)	80033	
Channel 5	On	0T	(+)	+ 0.00(in)	+ 1.69(in)	80034	
Channel 6	Off	N/A	N/A	N/A	N/A	80035	
Channel 7	Off	N/A	N/A	N/A	N/A	N/A	
Channel 8	Off	N/A	N/A	N/A	N/A	N/A	
						N/A	
						N/A	

Scan No.(s)	Increment & Scan Positions Actual				Recordable Indications			Analyst Remarks	
	Increment Position		Scan Position		Yes	No	N/A	Attachment: <input type="checkbox"/> Yes <input type="checkbox"/> No	
	Start	Stop	Start	Stop					
					Channel 1	<input type="checkbox"/>	<input type="checkbox"/>	<input type="checkbox"/>	Further Evaluation Required: <input type="checkbox"/> Yes <input type="checkbox"/> No Archive Tape/CD No.: Analysis Tape/CD No.:
					Channel 2	<input type="checkbox"/>	<input type="checkbox"/>	<input type="checkbox"/>	
					Channel 3	<input type="checkbox"/>	<input type="checkbox"/>	<input type="checkbox"/>	
					Channel 4	<input type="checkbox"/>	<input type="checkbox"/>	<input type="checkbox"/>	
					Channel 5	<input type="checkbox"/>	<input type="checkbox"/>	<input type="checkbox"/>	
					Channel 6	<input type="checkbox"/>	<input type="checkbox"/>	<input type="checkbox"/>	
					Channel 7	<input type="checkbox"/>	<input type="checkbox"/>	<input type="checkbox"/>	
					Channel 8	<input type="checkbox"/>	<input type="checkbox"/>	<input type="checkbox"/>	

Analyst / SNT Level / Date:
Hector Diaz III 1-May-03

Page 47/140



IHI SOUTHWEST TECHNOLOGIES AUTOMATED ULTRASONIC EXAMINATION RECORD

Site/Plant : Pilgrim Station	Weld Identification: RPV-L-2-338B	Pro/Rev/Chg/ICN: ISWT-PDI-AUT1/0/0/1,2	Examination No.: ID-10
Project No.: 02-0285	Weld Description: Ring 1 Vert @ 198°	Device Configuration: D-PNPS-102	
Mod.Conf.: A-07B	Scan Path Drawing: SPLONGSH1&4DS	Exam Date	Examination Time
Data Acquisition Operator (s) / SNT Level: Harper Jacoby / N/A		1-May-03	Surface Temperature °F
		Start	End
		1235	1250
		Start	End
		87	87

Scan Controller Parameters			Increment Axis/Arm			Scan Axis/Device			Positional Parameters	
Controller:	ID Device		Planned		Actual	Planned		Actual	Beam Direction:	Dn/Up
Scan:	Y Axis		Lower Limit	38452	38451	Lower Limit	12413	13700	Transducer Size:	1.00
Increment:	X Axis		Upper Limit	39712	39712	Upper Limit	15041	15041	Code % of Overlap:	10
Mode:	Automatic Scan		Increment Interval	90		DCI	4		Number of Scans:	15
Scan Motion:	Bi-directional		Conversion Counts	100		Conversion Counts	100		Device Position:	D (0)
Correction:	Default		Conversion Units In.	1.00		Conversion Units In.	1.00			
			EDAS Radius In.	113.10						

Module Parameters:						Calibration Records:		Examination Notes:	
Status	Angle	Direction	Scan Offset	Step Offset					
Channel 1	On	55	(-)	- 1.40(in)	- 1.21(in)	PNS-03		Check for limitations due to the proximity of the jet pump diffuser, the NI nozzle, and the baffle plate.	
Channel 2	On	55	(+)	+ 1.40(in)	- 1.21(in)	80031			
Channel 3	On	SLIC-40	(-)	- 1.97(in)	+ 1.69(in)	80032			
Channel 4	On	SLIC-40	(+)	+ 1.97(in)	+ 1.69(in)	80033			
Channel 5	On	0T	(+)	+ 0.00(in)	+ 1.69(in)	80034		Examination Remarks:	
Channel 6	Off	N/A	N/A	N/A	N/A	80035		Limited exam due to proximity of baffle plate gusset.	
Channel 7	Off	N/A	N/A	N/A	N/A	N/A			
Channel 8	Off	N/A	N/A	N/A	N/A	N/A			

Scan No.(s)	Increment & Scan Positions Actual				Recordable Indications			Analyst Remarks	
	Increment Position		Scan Position		Yes	No	N/A	Attachment:	
1 - 5	Start	Stop	Start	Stop	Channel 1	<input type="checkbox"/>	<input checked="" type="checkbox"/>	<input type="checkbox"/>	<input type="checkbox"/> Yes <input checked="" type="checkbox"/> No
	38471	39552	13621	15041	Channel 2	<input type="checkbox"/>	<input checked="" type="checkbox"/>	<input type="checkbox"/>	Further Evaluation
6 - 15	Start	Stop	Start	Stop	Channel 3	<input type="checkbox"/>	<input checked="" type="checkbox"/>	<input type="checkbox"/>	Required:
	38909	39728	13700	15041	Channel 4	<input type="checkbox"/>	<input checked="" type="checkbox"/>	<input type="checkbox"/>	<input type="checkbox"/> Yes <input checked="" type="checkbox"/> No
					Channel 5	<input type="checkbox"/>	<input checked="" type="checkbox"/>	<input type="checkbox"/>	Archive Tape/CD No.:
					Channel 6	<input type="checkbox"/>	<input type="checkbox"/>	<input checked="" type="checkbox"/>	5A
					Channel 7	<input type="checkbox"/>	<input type="checkbox"/>	<input checked="" type="checkbox"/>	Analysis Tape/CD No.:
					Channel 8	<input type="checkbox"/>	<input type="checkbox"/>	<input checked="" type="checkbox"/>	1A

Analyst / SNT Level / Date:
Hector Diaz *Hector Diaz* III 1-May-03

Page 48/140



IHI SOUTHWEST TECHNOLOGIES AUTOMATED ULTRASONIC EXAMINATION RECORD

Site/Plant: Pilgrim Station	Weld Identification: RPV-L-2-338B	Pro/Rev/Chg/ICN: ISwT-PDI-AUT1/0/0/1,2	Examination No.: ID-11
Project No.: 02-0285	Weld Description: Ring 1 Vert @ 198°	Device Configuration: D-PNPS-102	
Mod.Conf.: A-07B	Scan Path Drawing: SPLONGSH1&4DS	Exam Date: 1-May-03	Examination Time: Start 1256, End 1314
Data Acquisition Operator (s) / SNT Level: Harper Jacoby / N/A			Surface Temperature: Start 87, End 87

Scan Controller Parameters		Increment Axis/Arm	Planned	Actual	Scan Axis/Device	Planned	Actual	Positional Parameters	
Controller:	ID Device	Lower Limit	38452	38452	Lower Limit	14988	14988	Beam Direction:	Dn/Up
Scan:	Y Axis	Upper Limit	39712	39712	Upper Limit	17616	17616	Transducer Size:	1.00
Increment:	X Axis	Increment Interval	90		DCI	4		Code % of Overlap:	10
Mode:	Automatic Scan	Conversion Counts	100		Conversion Counts	100		Number of Scans:	15
Scan Motion:	Bi-directional	Conversion Units In.	1.00		Conversion Units In.	1.00		Device Position:	D (0)
Correction:	Default	EDAS Radius In.	113.10						

Module Parameters: A-07B Cal 03						Calibration Records:	Examination Notes:
Status	Angle	Direction	Scan Offset	Step Offset		PNS-03	
Channel 1	On	55	(-)	- 1.40(in)	- 1.21(in)	80031	Check for limitations due to the proximity of the jet pump diffuser, the N1 nozzle, and the baffle plate.
Channel 2	On	55	(+)	+ 1.40(in)	- 1.21(in)	80032	
Channel 3	On	SLIC-40	(-)	- 1.97(in)	+ 1.69(in)	80033	Examination Remarks:
Channel 4	On	SLIC-40	(+)	+ 1.97(in)	+ 1.69(in)	80034	
Channel 5	On	0T	(+)	+ 0.00(in)	+ 1.69(in)	80035	
Channel 6	Off	N/A	N/A	N/A	N/A	N/A	
Channel 7	Off	N/A	N/A	N/A	N/A	N/A	
Channel 8	Off	N/A	N/A	N/A	N/A	N/A	

Scan No.(s)	Increment & Scan Positions Actual				Recordable Indications			Analyst Remarks	
	Start	Stop	Start	Stop	Yes	No	N/A	Attachment:	
1 - 15	38451	39712	14988	17616	Channel 1 <input type="checkbox"/>	<input checked="" type="checkbox"/>	<input type="checkbox"/>	<input type="checkbox"/> Yes <input checked="" type="checkbox"/> No	
					Channel 2 <input type="checkbox"/>	<input checked="" type="checkbox"/>	<input type="checkbox"/>	Further Evaluation Required:	
					Channel 3 <input type="checkbox"/>	<input checked="" type="checkbox"/>	<input type="checkbox"/>	<input type="checkbox"/> Yes <input checked="" type="checkbox"/> No	
					Channel 4 <input type="checkbox"/>	<input checked="" type="checkbox"/>	<input type="checkbox"/>	Archive Tape/CD No.:	
					Channel 5 <input type="checkbox"/>	<input checked="" type="checkbox"/>	<input type="checkbox"/>	5A	
					Channel 6 <input type="checkbox"/>	<input type="checkbox"/>	<input checked="" type="checkbox"/>	Analysis Tape/CD No.:	
					Channel 7 <input type="checkbox"/>	<input type="checkbox"/>	<input checked="" type="checkbox"/>	1A	
					Channel 8 <input type="checkbox"/>	<input type="checkbox"/>	<input checked="" type="checkbox"/>		

Analyst / SNT Level / Date:
Hector Diaz

Hector Diaz

III

1-May-03

Page 49/140



IHI SOUTHWEST TECHNOLOGIES AUTOMATED ULTRASONIC EXAMINATION RECORD

Site/Plant: Pilgrim Station	Weld Identification: RPV-L-2-338B	Pro/Rev/Chg/ICN: ISwT-PDI-AUT1/0/0/1,2	Examination No.: ID-12
Project No.: 02-0285	Weld Description: Ring 1 Vert @ 198°	Device Configuration: D-PNPS-102	
Mod.Conf.: A-07A	Scan Path Drawing: SPLONGSH1&4DS	Exam Date: 1-May-03	Surface Temperature °F:
Data Acquisition Operator (s) / SNT Level: Harper Jacoby / N/A		Examination Time:	
		Start: 1358	End: 1406
		Start: 87	End: 87

Scan Controller Parameters		Increment Axis/Arm	Planned	Actual	Scan Axis/Device	Planned	Actual	Positional Parameters	
Controller:	ID Device	Lower Limit	38452	38452	Lower Limit	17563	17563	Beam Direction:	Up/Dn
Scan:	Y Axis	Upper Limit	39712	39712	Upper Limit	20191	20191	Transducer Size:	1.00
Increment:	X Axis	Increment Interval	90		DCI	4		Code % of Overlap:	10
Mode:	Automatic Scan	Conversion Counts	100		Conversion Counts	100		Number of Scans:	15
Scan Motion:	Bi-directional	Conversion Units In.	1.00		Conversion Units In.	1.00		Device Position:	D (180)
Correction:	Default	EDAS Radius In.	113.10						

Module Parameters: A-07A Cal 03						Calibration Records:	Examination Notes:
	Status	Angle	Direction	Scan Offset	Step Offset		
Channel 1	On	55	(+)	+ 1.40(in)	+ 1.21(in)	PNS-03	Check for limitations due to the proximity of the jet pump diffuser, the N1 nozzle, and the baffle plate.
Channel 2	On	55	(-)	- 1.40(in)	+ 1.21(in)	80031	
Channel 3	On	SLIC-40	(+)	+ 1.97(in)	- 1.69(in)	80032	
Channel 4	On	SLIC-40	(-)	- 1.97(in)	- 1.69(in)	80033	
Channel 5	On	0T	(+)	+ 0.00(in)	- 1.69(in)	80034	
Channel 6	Off	N/A	N/A	N/A	N/A	80035	Examination Remarks:
Channel 7	Off	N/A	N/A	N/A	N/A	N/A	
Channel 8	Off	N/A	N/A	N/A	N/A	N/A	

Scan No.(s)	Increment & Scan Positions Actual				Recordable Indications			Attachment: <input type="checkbox"/> Yes <input checked="" type="checkbox"/> No	Further Evaluation Required: <input type="checkbox"/> Yes <input checked="" type="checkbox"/> No	Analyst Remarks
	Start	Stop	Start	Stop	Yes	No	N/A			
1 - 15	38451	29796	17563	20191	Channel 1	<input type="checkbox"/>	<input checked="" type="checkbox"/>	<input type="checkbox"/>	Archive Tape/CD No.: SA Analysis Tape/CD No.: IA	
					Channel 2	<input type="checkbox"/>	<input checked="" type="checkbox"/>	<input type="checkbox"/>		
					Channel 3	<input type="checkbox"/>	<input checked="" type="checkbox"/>	<input type="checkbox"/>		
					Channel 4	<input type="checkbox"/>	<input checked="" type="checkbox"/>	<input type="checkbox"/>		
					Channel 5	<input type="checkbox"/>	<input checked="" type="checkbox"/>	<input type="checkbox"/>		
					Channel 6	<input type="checkbox"/>	<input type="checkbox"/>	<input checked="" type="checkbox"/>		
					Channel 7	<input type="checkbox"/>	<input type="checkbox"/>	<input checked="" type="checkbox"/>		
					Channel 8	<input type="checkbox"/>	<input type="checkbox"/>	<input checked="" type="checkbox"/>		

Analyst / SNT Level / Date:
Hector Diaz *Hector Diaz* III 1-May-03

80035/140



IHI SOUTHWEST TECHNOLOGIES AUTOMATED ULTRASONIC EXAMINATION RECORD

Site/Plant: Pilgrim Station	Weld Identification: RPV-L-2-338B	Pro/Rev/Chg/ICN: ISWT-PDI-AUT1/0/0/1,2	Examination No.: ID-13
Project No.: 02-0285	Weld Description: Ring 1 Vert @ 198°	Device Configuration: D-PNPS-102	
Mod.Conf.: A-07A	Scan Path Drawing: SPLONGSH1&4DS	Exam Date	Examination Time
Data Acquisition Operator (s) / SNT Level: Harper Jacoby / N/A		1-May-03	Surface Temperature °F
		Start	End
		1414	1425
		Start	End
		87	87

Scan Controller Parameters		Increment Axis/Arm	Planned	Actual	Scan Axis/Device	Planned	Actual	Positional Parameters	
Controller:	ID Device	Lower Limit	38452	38452	Lower Limit	20138	20138	Beam Direction:	Up/Dn
Scan:	Y Axis	Upper Limit	39712	39712	Upper Limit	22766	22766	Transducer Size:	1.00
Increment:	X Axis	Increment Interval	90		DCI	4		Code % of Overlap:	10
Mode:	Automatic Scan	Conversion Counts	100		Conversion Counts	100		Number of Scans:	15
Scan Motion:	Bi-directional	Conversion Units In.	1.00		Conversion Units In.	1.00		Device Position:	D (180)
Correction:	Default	EDAS Radius In.	113.10						

Module Parameters: A-07A Cal 03						Calibration Records:	Examination Notes:
Status	Angle	Direction	Scan Offset	Step Offset		PNS-03	Check for limitations due to the proximity of the jet pump diffuser, the NI nozzle, and the baffle plate.
Channel 1	On	55	(+)	+ 1.40(in)	+ 1.21(in)	80031	
Channel 2	On	55	(-)	- 1.40(in)	+ 1.21(in)	80032	
Channel 3	On	SLIC-40	(+)	+ 1.97(in)	- 1.69(in)	80033	
Channel 4	On	SLIC-40	(-)	- 1.97(in)	- 1.69(in)	80034	
Channel 5	On	0T	(+)	+ 0.00(in)	- 1.69(in)	80035	
Channel 6	Off	N/A	N/A	N/A	N/A	N/A	
Channel 7	Off	N/A	N/A	N/A	N/A	N/A	
Channel 8	Off	N/A	N/A	N/A	N/A	N/A	

Scan No.(s)	Increment & Scan Positions Actual				Recordable Indications			Analyst Remarks	
	Increment Position		Scan Position		Yes	No	N/A	Attachment:	
	Start	Stop	Start	Stop	Channel 1	<input type="checkbox"/>	<input checked="" type="checkbox"/>	<input type="checkbox"/>	<input type="checkbox"/> Yes <input checked="" type="checkbox"/> No
1 - 15	38451	39714	20138	22766	Channel 2	<input type="checkbox"/>	<input checked="" type="checkbox"/>	<input type="checkbox"/>	Further Evaluation
					Channel 3	<input type="checkbox"/>	<input checked="" type="checkbox"/>	<input type="checkbox"/>	Required:
					Channel 4	<input type="checkbox"/>	<input checked="" type="checkbox"/>	<input type="checkbox"/>	<input type="checkbox"/> Yes <input checked="" type="checkbox"/> No
					Channel 5	<input type="checkbox"/>	<input checked="" type="checkbox"/>	<input type="checkbox"/>	Archive Tape/CD No.:
					Channel 6	<input type="checkbox"/>	<input type="checkbox"/>	<input checked="" type="checkbox"/>	5A
					Channel 7	<input type="checkbox"/>	<input type="checkbox"/>	<input checked="" type="checkbox"/>	Analysis Tape/CD No.:
					Channel 8	<input type="checkbox"/>	<input type="checkbox"/>	<input checked="" type="checkbox"/>	1A

Analyst / SNT Level / Date:
Hector Diaz *Hector Diaz* III I-May-03

Page 51/140



IHI SOUTHWEST TECHNOLOGIES AUTOMATED ULTRASONIC EXAMINATION RECORD

Site/Plant : Pilgrim Station	Weld Identification: RPV-L-2-338B	Pro/Rev/Chg/ICN: ISWT-PDI-AUT1/0/0/1,2	Examination No.: ID-14
Project No.: 02-0285	Weld Description: Ring 1 Vert @ 198°	Device Configuration: D-PNPS-102	
Mod.Conf.: A-07A	Scan Path Drawing: SPLONGSHI&4DS	Exam Date	Examination Time
Data Acquisition Operator (s) / SNT Level: Harper Jacoby / N/A		1-May-03	Surface Temperature °F
		Start	End
		1433	1443
		Start	End
		87	87

Scan Controller Parameters		Increment Axis/Arm	Planned	Actual	Scan Axis/Device	Planned	Actual	Positional Parameters	
Controller:	ID Device	Lower Limit	38452	38452	Lower Limit	22713	22241	Beam Direction:	Up/Dn
Scan:	Y Axis	Upper Limit	39712	39712	Upper Limit	25341	25341	Transducer Size:	1.00
Increment:	X Axis	Increment Interval	90		DCI	4		Code % of Overlap:	10
Mode:	Automatic Scan	Conversion Counts	100		Conversion Counts	100		Number of Scans:	15
Scan Motion:	Bi-directional	Conversion Units In.	1.00		Conversion Units In.	1.00		Device Position:	D (180)
Correction:	Default	EDAS Radius In.	113.10						

Module Parameters:						Calibration Records:		Examination Notes:	
Status	Angle	Direction	Scan Offset	Step Offset					
Channel 1	On	55	(+)	+ 1.40(in)	+ 1.21(in)	PNS-03	Check for limitations due to the proximity of the jet pump diffuser, the N1 nozzle, and the baffle plate.		
Channel 2	On	55	(-)	- 1.40(in)	+ 1.21(in)	80031			
Channel 3	On	SLIC-40	(+)	+ 1.97(in)	- 1.69(in)	80032	Examination Remarks:		
Channel 4	On	SLIC-40	(-)	- 1.97(in)	- 1.69(in)	80033			
Channel 5	On	0T	(+)	+ 0.00(in)	- 1.69(in)	80034			
Channel 6	Off	N/A	N/A	N/A	N/A	80035			
Channel 7	Off	N/A	N/A	N/A	N/A	N/A			
Channel 8	Off	N/A	N/A	N/A	N/A	N/A			

Increment & Scan Positions Actual					Recordable Indications			Analyst Remarks	
Scan No.(s)	Increment Position		Scan Position		Yes	No	N/A	Attachment: <input type="checkbox"/> Yes <input checked="" type="checkbox"/> No	
	Start	Stop	Start	Stop					
1 - 15	38451	39694	22713	25341	Channel 1 <input type="checkbox"/>	<input checked="" type="checkbox"/>	<input type="checkbox"/>	Further Evaluation Required: <input type="checkbox"/> Yes <input checked="" type="checkbox"/> No Archive Tape/CD No.: 5A Analysis Tape/CD No.: 1A	
					Channel 2 <input type="checkbox"/>	<input checked="" type="checkbox"/>	<input type="checkbox"/>		
					Channel 3 <input type="checkbox"/>	<input checked="" type="checkbox"/>	<input type="checkbox"/>		
					Channel 4 <input type="checkbox"/>	<input checked="" type="checkbox"/>	<input type="checkbox"/>		
					Channel 5 <input type="checkbox"/>	<input checked="" type="checkbox"/>	<input type="checkbox"/>		
					Channel 6 <input type="checkbox"/>	<input type="checkbox"/>	<input checked="" type="checkbox"/>		
					Channel 7 <input type="checkbox"/>	<input type="checkbox"/>	<input checked="" type="checkbox"/>		
					Channel 8 <input type="checkbox"/>	<input type="checkbox"/>	<input checked="" type="checkbox"/>		

Analyst / SNT Level / Date:
Hector Diaz *Hector Diaz* III 1-May-03

Page 52/140



IHI SOUTHWEST TECHNOLOGIES AUTOMATED ULTRASONIC EXAMINATION RECORD

Site/Plant : Pilgrim Station	Weld Identification: RPV-L-2-338B	Pro/Rev/Chg/ICN: ISwT-PDI-AUT,1/0/0/1,2	Examination No.: ID-15
Project No.: 02-0285	Weld Description: Ring 1 Vert @ 198°	Device Configuration: D-PNPS-101	
Mod.Conf.: A-07-1D	Scan Path Drawing: SPLONGSH1&4DS	Exam Date	Examination Time
Data Acquisition Operator (s) / SNT Level: R.A. Riddles / II		1-May-03	Surface Temperature °F
		Start	End
		0543	0600
		Start	End
		87	87

Scan Controller Parameters		Increment Axis/Device		Scan Axis/Arm		Positional Parameters	
		Planned	Actual	Planned	Actual		
Controller:	ID Device	Lower Limit	10488	Lower Limit	38332	Beam Direction:	Ccw/Cw
Scan:	X Axis	Upper Limit	17508	Upper Limit	39832	Transducer Size:	1.00
Increment:	Y Axis	Increment Interval	90	DCI	4	Code % of Overlap:	10
Mode:	Automatic Scan	Conversion Counts	100	Conversion Counts	100	Number of Scans:	79
Scan Motion:	Bi-directional	Conversion Units In.	1.00	Conversion Units In.	1.00	Device Position:	A (0)
Correction:	Default	EDAS Radius In.	113.10				

Module Parameters:						Calibration Records:		Examination Notes:	
A-07-1D		Cal 33							
Status	Angle	Direction	Scan Offset	Step Offset					
Channel 1	On	55	(-)	+ 7.00(in)	+ 0.00(in)	PNS-33	Check for limitations due to the proximity of the jet pump diffuser, the NI nozzle, and the baffle plate.		
Channel 2	On	55	(+)	- 7.00(in)	+ 0.00(in)	80331			
Channel 3	On	SLIC-40	(-)	+ 4.40(in)	+ 1.00(in)	80332	Examination Remarks: Limited exam due to proximity of baffle plate gusset.		
Channel 4	On	SLIC-40	(+)	- 4.40(in)	- 1.00(in)	80333			
Channel 5	On	0T	(+)	+ 4.40(in)	- 1.00(in)	80334			
Channel 6	On	0T	(+)	- 4.40(in)	+ 1.00(in)	80335			
Channel 7	Off	N/A	N/A	N/A	N/A	N/A			
Channel 8	Off	N/A	N/A	N/A	N/A	N/A			

Scan No.(s)	Increment & Scan Positions Actual				Recordable Indications			Analyst Remarks	
	Increment Position		Scan Position		Yes	No	N/A		
	Start	Stop	Start	Stop	Channel 1	<input type="checkbox"/>	<input checked="" type="checkbox"/>	<input type="checkbox"/>	Attachment:
36 - 79	13631	17569	38332	39832	Channel 2	<input type="checkbox"/>	<input checked="" type="checkbox"/>	<input type="checkbox"/>	<input type="checkbox"/> Yes <input checked="" type="checkbox"/> No
					Channel 3	<input type="checkbox"/>	<input checked="" type="checkbox"/>	<input type="checkbox"/>	Further Evaluation
					Channel 4	<input type="checkbox"/>	<input checked="" type="checkbox"/>	<input type="checkbox"/>	Required:
					Channel 5	<input type="checkbox"/>	<input checked="" type="checkbox"/>	<input type="checkbox"/>	<input type="checkbox"/> Yes <input checked="" type="checkbox"/> No
					Channel 6	<input type="checkbox"/>	<input type="checkbox"/>	<input checked="" type="checkbox"/>	Archive Tape/CD No.:
					Channel 7	<input type="checkbox"/>	<input type="checkbox"/>	<input checked="" type="checkbox"/>	5A
					Channel 8	<input type="checkbox"/>	<input type="checkbox"/>	<input checked="" type="checkbox"/>	Analysis Tape/CD No.:
									1A

Analyst / SNT Level / Date:
Hector Diaz *Hector Diaz* III 1-May-03

Page 53/140



IH SOUTHWEST TECHNOLOGIES AUTOMATED ULTRASONIC EXAMINATION RECORD

Site/Plant : Pilgrim Station	Weld Identification: RPV-L-2-338B	Pro/Rev/Chg/ICN: ISWT-PDI-AUT1/0/0/1,2	Examination No.: ID-16
Project No.: 02-0285	Weld Description: Ring 1 Vert @ 198°	Device Configuration: D-PNPS-101	
Mod.Conf.: A-07-1C	Scan Path Drawing: SPLONGSH1&4DS	Exam Date: 1-May-03	Examination Time: Start 0603, End 0648
Data Acquisition Operator (s) / SNT Level: R.A. Riddles / II			Surface Temperature: Start 87, End 87

Scan Controller Parameters		Increment Axis/Arm	Planned	Actual	Scan Axis/Device	Planned	Actual	Positional Parameters	
Controller:	ID Device	Lower Limit	17418	17431	Lower Limit	38332	38332	Beam Direction:	Cw/Ccw
Scan:	X Axis	Upper Limit	24438	24432	Upper Limit	39832	39832	Transducer Size:	1.00
Increment:	Y Axis	Increment Interval	90		DCI	4		Code % of Overlap:	10
Mode:	Automatic Scan	Conversion Counts	100		Conversion Counts	100		Number of Scans:	79
Scan Motion:	Bi-directional	Conversion Units In.	1.00		Conversion Units In.	1.00		Device Position:	A (180)
Correction:	Default	EDAS Radius In.	113.10						

Module Parameters: A-07-1C Cal 33						Calibration Records:	Examination Notes:
Channel	Status	Angle	Direction	Scan Offset	Step Offset		
Channel 1	On	55	(+)	- 7.00(in)	+ 0.00(in)	PNPS-33	Check for limitations due to the proximity of the jet pump diffuser, the N1 nozzle, and the baffle plate.
Channel 2	On	55	(-)	+ 7.00(in)	+ 0.00(in)	80331	
Channel 3	On	SLIC-40	(+)	- 4.40(in)	- 1.00(in)	80332	
Channel 4	On	SLIC-40	(-)	+ 4.40(in)	+ 1.00(in)	80333	
Channel 5	On	0T	(+)	- 4.40(in)	+ 1.00(in)	80334	Examination Remarks: Limited exam due to proximity of the N2F nozzle.
Channel 6	On	0T	(+)	+ 4.40(in)	- 1.00(in)	80335	
Channel 7	Off	N/A	N/A	N/A	N/A	80336	
Channel 8	Off	N/A	N/A	N/A	N/A	N/A	

Increment & Scan Positions Actual					Recordable Indications			Analyst Remarks	
Scan No.(s)	Increment Position		Scan Position		Yes	No	N/A	Attachment: <input type="checkbox"/> Yes <input checked="" type="checkbox"/> No	Further Evaluation Required: <input type="checkbox"/> Yes <input checked="" type="checkbox"/> No
	Start	Stop	Start	Stop	Channel 1	Channel 2	Channel 3		
1 - 20	17431	19155	38332	39832	<input type="checkbox"/>	<input checked="" type="checkbox"/>	<input type="checkbox"/>	Channel 6 inactive.	
21 - 34	19237	20410	38332	39050	<input type="checkbox"/>	<input checked="" type="checkbox"/>	<input type="checkbox"/>		
35 - 43	20499	21175	38332	39090	<input type="checkbox"/>	<input checked="" type="checkbox"/>	<input type="checkbox"/>		
44 - 50	21284	21804	38332	38950	<input type="checkbox"/>	<input checked="" type="checkbox"/>	<input type="checkbox"/>		
51 - 73	21897	23886	38332	39560	<input type="checkbox"/>	<input type="checkbox"/>	<input checked="" type="checkbox"/>		
74 - 79	23978	24427	38332	39832	<input type="checkbox"/>	<input type="checkbox"/>	<input checked="" type="checkbox"/>		
					<input type="checkbox"/>	<input type="checkbox"/>	<input checked="" type="checkbox"/>		
					<input type="checkbox"/>	<input type="checkbox"/>	<input checked="" type="checkbox"/>		

Analyst / SNT Level / Date: Hector Diaz III 1-May-03

Page 54/140

ISWT EXAMINATION SUMMARY RECORD

Project No.: 02-0285

PILGRIM NUCLEAR POWER STATION

Summary Sheet No.: 000700

SITE: PILGRIM STATION
SYSTEM: REACTOR PRESSURE VESSEL
LINE/SUBASSEMBLY: RING 3 VERTICAL WELD @ 356-DEGREES
IDENTIFICATION: RPV-L-2-339A

NDE Method	Proc/Rev/Chg/ICN	NDE Examination	Calibration Sheet No.	Data Sheet No.	N O		Resolution Record	CNF Number	Remarks
					R	T			
AUT	ISWT-PDI-AUT1/0/0/1,2	AUTO	80335,80336	exam 43-46	X	-	N/A	N/A	Examination no's 39-46.
AUT	ISWT-PDI-AUT1/0/0/1,2	AUT55	80331,80332	exam 43-46	X	-	N/A	N/A	AUTO for thickness measurement only.
AUT	ISWT-PDI-AUT1/0/0/1,2	AUTSLIC40	80333,80334	exam 43-46	X	-	N/A	N/A	
AUT	ISWT-PDI-AUT1/0/0/1,2	AUT55T	80031,80032	exam 39-42	X	-	N/A	N/A	
AUT	ISWT-PDI-AUT1/0/0/1,2	AUTSLIC40T	80033,80034	exam 39-42	X	-	N/A	N/A	
AUT	ISWT-PDI-AUT1/0/0/1,2	AUTO	80035	exam 39-42	X	-	N/A	N/A	

- NOTES:
1. Weld RPV-L-2-339A was examined from the inside surface using AIRIS-21 and EDAS-II examination equipment.
 2. No recordable indications were detected during this examination.
 3. The examination was limited due to proximity of feedwater and core spray spargers, 81% examination coverage was achieved.

****UT CALIBRATION BLOCK(S)****
 D-70187-2/D70380-1

Prepared by: Steven J. Todd
 Steven J. Todd - Project Engineer

Date: 04-May-03

Page 1 of 1

Page 55/140



IHI SOUTHWEST TECHNOLOGIES AUTOMATED ULTRASONIC EXAMINATION RECORD

Site/Plant : Pilgrim Station	Weld Identification: RPV-L-2-339A	Pro/Rev/Chg/ICN: ISWT-PDI-AUT1/0/0/1,2	Examination No.: ID-39
Project No.: 02-0285	Weld Description: Ring 3 Vert @ 356°	Device Configuration: D-PNPS-102	
Mod.Conf.: A-07B	Scan Path Drawing: SPLONGSH2&3DS	Exam Date: 28-Apr-03	Surface Temperature °F
Data Acquisition Operator (s) / SNT Level: Harper Jacoby / N/A		Examination Time	Start End
		1154 1206	96 96

Scan Controller Parameters				Increment Axis/Arm			Scan Axis/Device			Positional Parameters	
Controller:	ID Device	Lower Limit	Planned	Actual	Lower Limit	Planned	Actual	Beam Direction:	Dn/Up		
Scan:	Y Axis	Upper Limit	71210	71210	Upper Limit	42814	42814	Transducer Size:	1.00		
Increment:	X Axis	Increment Interval	90		DCI	4		Code % of Overlap:	10		
Mode:	Automatic Scan	Conversion Counts	100		Conversion Counts	100		Number of Scans:	15		
Scan Motion:	Bi-directional	Conversion Units In.	1.00		Conversion Units In.	1.00		Device Position:	D (0)		
Correction:	Default	EDAS Radius In.	113.60								

Module Parameters: A-07B Cal 03						Calibration Records:		Examination Notes:	
Channel	Status	Angle	Direction	Scan Offset	Step Offset	PNS-03		Check for limitations due to the proximity of the feedwater and core spray spargers and the guide rod.	
Channel 1	On	55	(-)	- 1.40(in)	- 1.21(in)	80031			
Channel 2	On	55	(+)	+ 1.40(in)	- 1.21(in)	80032			
Channel 3	On	SLIC-40	(-)	- 1.97(in)	+ 1.69(in)	80033			
Channel 4	On	SLIC-40	(+)	+ 1.97(in)	+ 1.69(in)	80034			
Channel 5	On	0T	(+)	+ 0.00(in)	+ 1.69(in)	80035			
Channel 6	Off	N/A	N/A	N/A	N/A	N/A			
Channel 7	Off	N/A	N/A	N/A	N/A	N/A			
Channel 8	Off	N/A	N/A	N/A	N/A	N/A			

Scan No.(s)	Increment & Scan Positions Actual				Recordable Indications			Analyst Remarks	
	Increment Position		Scan Position		Yes	No	N/A	Attachment: <input type="checkbox"/> Yes <input checked="" type="checkbox"/> No	
	Start	Stop	Start	Stop	Channel 1	Channel 2	Channel 3		
1 - 15	69950	71210	38750	42806	<input type="checkbox"/>	<input checked="" type="checkbox"/>	<input type="checkbox"/>	Further Evaluation Required: <input type="checkbox"/> Yes <input checked="" type="checkbox"/> No	
					Channel 4	Channel 5	Channel 6	Archive Tape/CD No.: 3A	
					Channel 7	Channel 8		Analysis Tape/CD No.: 1A	

Analyst / SNT Level / Date: **Hector Diaz** *Hector Diaz* III 29-Apr-03

Page 56/140



IHI SOUTHWEST TECHNOLOGIES AUTOMATED ULTRASONIC EXAMINATION RECORD

Site/Plant: Pilgrim Station	Weld Identification: RPV-L-2-339A	Pro/Rev/Chg/ICN: ISWT-PDI-AUT1/0/0/1,2	Examination No.: ID-40
Project No.: 02-0285	Weld Description: Ring 3 Vert @ 356°	Device Configuration: D-PNPS-102	
Mod.Conf.: A-07A	Scan Path Drawing: SPLONGSH2&3DS	Exam Date: 28-Apr-03	Surface Temperature °F
Data Acquisition Operator (s) / SNT Level: Harper Jacoby / N/A		Examination Time	Start End
		1129 1144	96 96

Scan Controller Parameters		Increment Axis/Arm	Planned	Actual	Scan Axis/Device	Planned	Actual	Positional Parameters	
Controller:	ID Device	Lower Limit	69950	69950	Lower Limit	42763	42763	Beam Direction:	Up/Dn
Scan:	Y Axis	Upper Limit	71210	71210	Upper Limit	46827	46827	Transducer Size:	1.00
Increment:	X Axis	Increment Interval	90		DCI	4		Code % of Overlap:	10
Mode:	Automatic Scan	Conversion Counts	100		Conversion Counts	100		Number of Scans:	15
Scan Motion:	Bi-directional	Conversion Units In.	1.00		Conversion Units In.	1.00		Device Position:	D (180)
Correction:	Default	EDAS Radius In.	113.60						

Module Parameters:						Calibration Records:		Examination Notes:	
	Status	Angle	Direction	Scan Offset	Step Offset				
Channel 1	On	55	(+)	+ 1.40(in)	+ 1.21(in)	PNS-03	80031	Check for limitations due to the proximity of the feedwater and core spray spargers and the guide rod.	
Channel 2	On	55	(-)	- 1.40(in)	+ 1.21(in)	80032			
Channel 3	On	SLIC-40	(+)	+ 1.97(in)	- 1.69(in)	80033			
Channel 4	On	SLIC-40	(-)	- 1.97(in)	- 1.69(in)	80034		Examination Remarks:	
Channel 5	On	0T	(+)	+ 0.00(in)	- 1.69(in)	80035		Limited exam due to proximity of core spray sparger.	
Channel 6	Off	N/A	N/A	N/A	N/A	N/A			
Channel 7	Off	N/A	N/A	N/A	N/A	N/A			
Channel 8	Off	N/A	N/A	N/A	N/A	N/A			

Increment & Scan Positions Actual					Recordable Indications			Analyst Remarks	
Scan No.(s)	Increment Position		Scan Position		Yes	No	N/A		
	Start	Stop	Start	Stop					
1 - 7	69950	70339	42763	46115	Channel 1 <input type="checkbox"/>	<input checked="" type="checkbox"/>	<input type="checkbox"/>	Attachment: <input type="checkbox"/> Yes <input checked="" type="checkbox"/> No	
6 - 15	70351	71210	42763	46827	Channel 2 <input type="checkbox"/>	<input checked="" type="checkbox"/>	<input type="checkbox"/>	Further Evaluation Required: <input type="checkbox"/> Yes <input checked="" type="checkbox"/> No	
					Channel 3 <input type="checkbox"/>	<input checked="" type="checkbox"/>	<input type="checkbox"/>	Archive Tape/CD No.: 3A	
					Channel 4 <input type="checkbox"/>	<input checked="" type="checkbox"/>	<input type="checkbox"/>	Analysis Tape/CD No.: 1A	
					Channel 5 <input type="checkbox"/>	<input checked="" type="checkbox"/>	<input type="checkbox"/>		
					Channel 6 <input type="checkbox"/>	<input type="checkbox"/>	<input checked="" type="checkbox"/>		
					Channel 7 <input type="checkbox"/>	<input type="checkbox"/>	<input checked="" type="checkbox"/>		
					Channel 8 <input type="checkbox"/>	<input type="checkbox"/>	<input checked="" type="checkbox"/>		

Analyst / SNT Level / Date: **Hector Diaz** *Hector Diaz* 29-Apr-03

Boqr 57/240



IHI SOUTHWEST TECHNOLOGIES AUTOMATED ULTRASONIC EXAMINATION RECORD

Site/Plant : Pilgrim Station	Weld Identification: RPV-L-2-339A	Pro/Rev/Chg/ICN: ISwT-PDI-AUT1/0/0/1,2	Examination No.: ID-41
Project No.: 02-0285	Weld Description: Ring 3 Vert @ 356°	Device Configuration: D-PNPS-102	
Mod.Conf.: A-07B	Scan Path Drawing: SPLONGSH2&3DS	Exam Date: 28-Apr-03	Examination Time: Start 0936, End 0956
Data Acquisition Operator (s) / SNT Level: Harper Jacoby / N/A			Surface Temperature °F: Start 96, End 96

Scan Controller Parameters		Increment Axis/Arm	Planned	Actual	Scan Axis/Device	Planned	Actual	Positional Parameters	
Controller:	ID Device	Lower Limit	69950	69950	Lower Limit	46776	46760	Beam Direction:	Dn/Up
Scan:	Y Axis	Upper Limit	71210	71210	Upper Limit	52096	50400	Transducer Size:	1.00
Increment:	X Axis	Increment Interval	90		DCI	4		Code % of Overlap:	10
Mode:	Automatic Scan	Conversion Counts	100		Conversion Counts	100		Number of Scans:	15
Scan Motion:	Bi-directional	Conversion Units In.	1.00		Conversion Units In.	1.00		Device Position:	D (0)
Correction:	Default	EDAS Radius In.	113.60						

Module Parameters: A-07B Cal 03						Calibration Records:	Examination Notes:
Channel	Status	Angle	Direction	Scan Offset	Step Offset		
Channel 1	On	55	(-)	- 1.40(in)	- 1.21(in)	PNS-03	Check for limitations due to the proximity of the feedwater and core spray spargers and the guide rod.
Channel 2	On	55	(+)	+ 1.40(in)	- 1.21(in)	80031	
Channel 3	On	SLIC-40	(-)	- 1.97(in)	+ 1.69(in)	80032	
Channel 4	On	SLIC-40	(+)	+ 1.97(in)	+ 1.69(in)	80033	
Channel 5	On	0T	(+)	+ 0.00(in)	+ 1.69(in)	80034	Examination Remarks: Limited exam due to proximity of core spray sparger.
Channel 6	Off	N/A	N/A	N/A	N/A	80035	
Channel 7	Off	N/A	N/A	N/A	N/A	N/A	
Channel 8	Off	N/A	N/A	N/A	N/A	N/A	

Scan No.(s)	Increment & Scan Positions Actual				Recordable Indications			Analyst Remarks	
	Increment Position		Scan Position		Yes	No	N/A	Attachment: <input type="checkbox"/> Yes <input checked="" type="checkbox"/> No	Further Evaluation Required: <input type="checkbox"/> Yes <input checked="" type="checkbox"/> No
	Start	Stop	Start	Stop					
1 - 15	69950	71210	46760	50400	Channel 1 <input type="checkbox"/>	Channel 2 <input checked="" type="checkbox"/>	Channel 3 <input type="checkbox"/>	Channel 4 <input type="checkbox"/>	Channel 5 <input type="checkbox"/>
					Channel 6 <input type="checkbox"/>	Channel 7 <input type="checkbox"/>	Channel 8 <input checked="" type="checkbox"/>		

Analyst / SNT Level / Date:
Hector Diaz *Hector Diaz* III 29-Apr-03

Page 58/140



IHI SOUTHWEST TECHNOLOGIES AUTOMATED ULTRASONIC EXAMINATION RECORD

Site/Plant: Pilgrim Station	Weld Identification: RPV-L-2-339A	Pro/Rev/Chg/ICN: ISwT-PDI-AUT/1/0/0/1,2	Examination No.: JD-42
Project No.: 02-0285	Weld Description: Ring 3 Vert @ 356°	Device Configuration: D-PNPS-102	
Mod.Conf.: A-07A	Scan Path Drawing: SPLONGSH2&3DS	Exam Date: 28-Apr-03	Surface Temperature °F:
Data Acquisition Operator (s) / SNT Level: Harper Jacoby	/ N/A	Examination Time:	
		Start: 1004	End: 1010
		Start: 96	End: 96

Scan Controller Parameters				Increment Axis/Arm	Planned	Actual	Scan Axis/Device	Planned	Actual	Positional Parameters	
Controller:	ID Device	Lower Limit	69950	69950	Lower Limit	46776	50300	Beam Direction:	Up/Dn		
Scan:	Y Axis	Upper Limit	71210	71210	Upper Limit	51744	51744	Transducer Size:	1.00		
Increment:	X Axis	Increment Interval	90		DCI	4		Code % of Overlap:	10		
Mode:	Automatic Scan	Conversion Counts	100		Conversion Counts	100		Number of Scans:	15		
Scan Motion:	Bi-directional	Conversion Units In.	1.00		Conversion Units In.	1.00		Device Position:	D (180)		
Correction:	Default	EDAS Radius In.	113.60								

Module Parameters:						Calibration Records:	Examination Notes:
Status	Angle	Direction	Scan Offset	Step Offset			
Channel 1	On	55	(+)	+ 1.40(in)	+ 1.21(in)	PNS-03	Check for limitations due to the proximity of the feedwater and core spray spargers and the guide rod.
Channel 2	On	55	(-)	- 1.40(in)	+ 1.21(in)	80031	
Channel 3	On	SLIC-40	(+)	+ 1.97(in)	- 1.69(in)	80032	
Channel 4	On	SLIC-40	(-)	- 1.97(in)	- 1.69(in)	80033	
Channel 5	On	0T	(+)	+ 0.00(in)	- 1.69(in)	80034	Examination Remarks: Limited exam due to proximity of core spray sparger.
Channel 6	Off	N/A	N/A	N/A	N/A	80035	
Channel 7	Off	N/A	N/A	N/A	N/A	N/A	
Channel 8	Off	N/A	N/A	N/A	N/A	N/A	

Increment & Scan Positions Actual					Recordable Indications			Analyst Remarks	
Scan No.(s)	Increment Position		Scan Position		Yes	No	N/A	Attachment:	Further Evaluation
	Start	Stop	Start	Stop					
1 - 15	69950	71210	50300	51700	Channel 1 <input type="checkbox"/>	<input checked="" type="checkbox"/>	<input type="checkbox"/>	<input type="checkbox"/> Yes <input checked="" type="checkbox"/> No	
					Channel 2 <input type="checkbox"/>	<input checked="" type="checkbox"/>	<input type="checkbox"/>	Required:	
					Channel 3 <input type="checkbox"/>	<input checked="" type="checkbox"/>	<input type="checkbox"/>	<input type="checkbox"/> Yes <input checked="" type="checkbox"/> No	
					Channel 4 <input type="checkbox"/>	<input checked="" type="checkbox"/>	<input type="checkbox"/>	Archive Tape/CD No.:	
					Channel 5 <input type="checkbox"/>	<input checked="" type="checkbox"/>	<input type="checkbox"/>	3A	
					Channel 6 <input type="checkbox"/>	<input type="checkbox"/>	<input checked="" type="checkbox"/>	Analysis Tape/CD No.:	
					Channel 7 <input type="checkbox"/>	<input type="checkbox"/>	<input checked="" type="checkbox"/>	1A	
					Channel 8 <input type="checkbox"/>	<input type="checkbox"/>	<input checked="" type="checkbox"/>		

Analyst / SNT Level / Date:
Hector Diaz *Hector Diaz* III 29-Apr-03

Page 59/140



IHI SOUTHWEST TECHNOLOGIES AUTOMATED ULTRASONIC EXAMINATION RECORD

Site/Plant: Pilgrim Station	Weld Identification: RPV-L-2-339A	Pro/Rev/Chg/ICN: ISwT-PDI-AUT1/0/0/1,2	Examination No.: ID-43
Project No.: 02-0285	Weld Description: Ring 3 Vert @ 356°	Device Configuration: D-PNPS-101	
Mod.Conf.: A-07-1D	Scan Path Drawing: SPLONGSH2&3DS	Exam Date: 29-Apr-03	Surface Temperature °F
Data Acquisition Operator (s) / SNT Level: R.A. Riddles / II		Start: 0150	End: 0202
		Start: 87	End: 78

Scan Controller Parameters		Increment Axis/Arm	Planned	Actual	Scan Axis/Device	Planned	Actual	Positional Parameters	
Controller:	ID Device	Lower Limit	39650	39638	Lower Limit	69830	69830	Beam Direction:	Ccw/Cw
Scan:	X Axis	Upper Limit	43340	43330	Upper Limit	71330	71330	Transducer Size:	1.00
Increment:	Y Axis	Increment Interval	90		DCI	4		Code % of Overlap:	10
Mode:	Automatic Scan	Conversion Counts	100		Conversion Counts	100		Number of Scans:	42
Scan Motion:	Bi-directional	Conversion Units In.	1.00		Conversion Units In.	1.00		Device Position:	A (0)
Correction:	Default	EDAS Radius In.	113.60						

Module Parameters: A-07-1D Cal 33						Calibration Records:	Examination Notes:
Channel	Status	Angle	Direction	Scan Offset	Step Offset		
Channel 1	On	55	(-)	+ 7.00(in)	+ 0.00(in)	PNS-33	Check for limitations due to the proximity of the feedwater and core spray spargers and the guide rail.
Channel 2	On	55	(+)	- 7.00(in)	+ 0.00(in)	80331	
Channel 3	On	SLIC-40	(-)	+ 4.40(in)	+ 1.00(in)	80332	
Channel 4	On	SLIC-40	(+)	- 4.40(in)	- 1.00(in)	80333	
Channel 5	On	0T	(+)	+ 4.40(in)	- 1.00(in)	80334	
Channel 6	On	0T	(+)	- 4.40(in)	+ 1.00(in)	80335	
Channel 7	Off	N/A	N/A	N/A	N/A	80336	
Channel 8	Off	N/A	N/A	N/A	N/A	N/A	

Scan No.(s)	Increment & Scan Positions Actual				Recordable Indications			Analyst Remarks	
	Increment Position		Scan Position		Yes	No	N/A	Attachment: <input type="checkbox"/> Yes <input checked="" type="checkbox"/> No	
	Start	Stop	Start	Stop					
1 - 42	39646	43340	69830	71330	Channel 1 <input type="checkbox"/>	Channel 2 <input checked="" type="checkbox"/>	Channel 3 <input type="checkbox"/>	Channel 6 inactive.	
					Channel 4 <input type="checkbox"/>	Channel 5 <input checked="" type="checkbox"/>	Channel 6 <input type="checkbox"/>	Further Evaluation Required:	
					Channel 7 <input type="checkbox"/>	Channel 8 <input checked="" type="checkbox"/>		<input type="checkbox"/> Yes <input checked="" type="checkbox"/> No	
								Archive Tape/CD No.:	
								4A	
								Analysis Tape/CD No.:	
								1A	

Analyst / SNT Level / Date:
Hector Diaz *Hector Diaz* III 29-Apr-03

Page 60/140



IHI SOUTHWEST TECHNOLOGIES AUTOMATED ULTRASONIC EXAMINATION RECORD

Site/Plant: Pilgrim Station	Weld Identification: RPV-L-2-339A	Pro/Rev/Chg/ICN: ISwT-PDI-AUT1/0/0/1,2	Examination No.: ID-44
Project No.: 02-0285	Weld Description: Ring 3 Vert @ 356°	Device Configuration: D-PNPS-101	
Mod.Conf.: A-07-1C	Scan Path Drawing: SPLONGSH2&3DS	Exam Date: 29-Apr-03	Surface Temperature °F
Data Acquisition Operator (s) / SNT Level: R.A. Riddles / II		Examination Time	Start End
		0213 222	87 78

Scan Controller Parameters		Increment Axis/Arm	Planned	Actual	Scan Axis/Device	Planned	Actual	Positional Parameters	
Controller:	ID Device	Lower Limit	43213	43215	Lower Limit	69830	69830	Beam Direction:	Cw/Ccw
Scan:	X Axis	Upper Limit	46903	45114	Upper Limit	71330	71330	Transducer Size:	1.00
Increment:	Y Axis	Increment Interval	90		DCI	4		Code % of Overlap:	10
Mode:	Automatic Scan	Conversion Counts	100		Conversion Counts	100		Number of Scans:	42
Scan Motion:	Bi-directional	Conversion Units In.	1.00		Conversion Units In.	1.00		Device Position:	A (180)
Correction:	Default	EDAS Radius In.	113.60						

Module Parameters: A-07-1C Cal 33						Calibration Records:	Examination Notes:
Channel	Status	Angle	Direction	Scan Offset	Step Offset		
Channel 1	On	55	(+)	- 7.00(in)	+ 0.00(in)	PNS-33 80331	Check for limitations due to the proximity of the feedwater and core spray spargers and the guide rod.
Channel 2	On	55	(-)	+ 7.00(in)	+ 0.00(in)	80332	
Channel 3	On	SLIC-40	(+)	- 4.40(in)	- 1.00(in)	80333	Examination Remarks: Limited exam due to proximity of core spray sparger.
Channel 4	On	SLIC-40	(-)	+ 4.40(in)	+ 1.00(in)	80334	
Channel 5	On	0T	(+)	- 4.40(in)	+ 1.00(in)	80335	
Channel 6	On	0T	(+)	+ 4.40(in)	- 1.00(in)	80336	
Channel 7	Off	N/A	N/A	N/A	N/A	N/A	
Channel 8	Off	N/A	N/A	N/A	N/A	N/A	

Scan No.(s)	Increment & Scan Positions Actual				Recordable Indications			Analyst Remarks	
	Increment Position		Scan Position		Yes	No	N/A	Attachment: <input type="checkbox"/> Yes <input checked="" type="checkbox"/> No	
	Start	Stop	Start	Stop					
1 - 22	43213	45108	69830	71330	Channel 1 <input type="checkbox"/>	Channel 2 <input checked="" type="checkbox"/>	Channel 3 <input type="checkbox"/>	Channel 6 inactive.	
					Channel 4 <input type="checkbox"/>	Channel 5 <input checked="" type="checkbox"/>	Channel 6 <input type="checkbox"/>	Further Evaluation Required: <input type="checkbox"/> Yes <input checked="" type="checkbox"/> No	
					Channel 7 <input type="checkbox"/>	Channel 8 <input checked="" type="checkbox"/>		Archive Tape/CD No.: 4A	
								Analysis Tape/CD No.: 1A	

Analyst / SNT Level / Date:
Hector Diaz *Hector Diaz* III 29-Apr-03

Page 61/740



IHI SOUTHWEST TECHNOLOGIES AUTOMATED ULTRASONIC EXAMINATION RECORD

Site/Plant : Pilgrim Station	Weld Identification: RPV-L-2-339A	Pro/Rev/Chg/ICN: ISwT-PDI-AUT1/0/0/1,2	Examination No.: ID-45
Project No.: 02-0285	Weld Description: Ring 3 Vert @ 356°	Device Configuration: D-PNPS-101	
Mod.Conf.: A-07-1D	Scan Path Drawing: SPLONGSH2&3DS	Exam Date: 29-Apr-03	Surface Temperature °F:
Data Acquisition Operator (s) / SNT Level: R.A. Riddles / II		Examination Time:	
		Start: 0213	End: 0222
		Start: 87	End: 78

Scan Controller Parameters		Increment Axis/Arm	Planned	Actual	Scan Axis/Device	Planned	Actual	Positional Parameters	
Controller:	ID Device	Lower Limit	46776	47745	Lower Limit	69830	69830	Beam Direction:	Ccw/Cw
Scan:	X Axis	Upper Limit	51186	50620	Upper Limit	71330	71330	Transducer Size:	1.00
Increment:	Y Axis	Increment Interval	90		DCI	4		Code % of Overlap:	10
Mode:	Automatic Scan	Conversion Counts	100		Conversion Counts	100		Number of Scans:	50
Scan Motion:	Bi-directional	Conversion Units In.	1.00		Conversion Units In.	1.00		Device Position:	A (0)
Correction:	Default	EDAS Radius In.	113.60						

Module Parameters: A-07-1D Cal 33						Calibration Records:	Examination Notes:
Channel	Status	Angle	Direction	Scan Offset	Step Offset		
Channel 1	On	55	(-)	+ 7.00(in)	+ 0.00(in)	PNS-33	Check for limitations due to the proximity of the feedwater and core spray spargers and the guide rod.
Channel 2	On	55	(+)	- 7.00(in)	+ 0.00(in)	80331	
Channel 3	On	SLIC-40	(-)	+ 4.40(in)	+ 1.00(in)	80332	
Channel 4	On	SLIC-40	(+)	- 4.40(in)	- 1.00(in)	80333	
Channel 5	On	0T	(+)	+ 4.40(in)	- 1.00(in)	80334	Examination Remarks: Limited exam due to proximity of core spray sparger.
Channel 6	On	0T	(+)	- 4.40(in)	+ 1.00(in)	80335	
Channel 7	Off	N/A	N/A	N/A	N/A	80336	
Channel 8	Off	N/A	N/A	N/A	N/A	N/A	

Increment & Scan Positions Actual					Recordable Indications			Analyst Remarks	
Scan No.(s)	Increment Position		Scan Position		Yes	No	N/A	Attachment: <input type="checkbox"/> Yes <input checked="" type="checkbox"/> No	Further Evaluation Required: <input type="checkbox"/> Yes <input checked="" type="checkbox"/> No
	Start	Stop	Start	Stop					
12 - 44	47738	50620	69830	71330	Channel 1 <input type="checkbox"/>	Channel 2 <input checked="" type="checkbox"/>	Channel 3 <input type="checkbox"/>	Channel 6 inactive.	Archive Tape/CD No.: 4A
					Channel 4 <input type="checkbox"/>	Channel 5 <input checked="" type="checkbox"/>	Channel 6 <input type="checkbox"/>		
					Channel 7 <input type="checkbox"/>	Channel 8 <input checked="" type="checkbox"/>			

Analyst / SNT Level / Date:
Hector Diaz *Hector Diaz* III 29-Apr-03

Page 62/140



IHI SOUTHWEST TECHNOLOGIES AUTOMATED ULTRASONIC EXAMINATION RECORD

Site/Plant : Pilgrim Station	Weld Identification: RPV-L-2-339A	Pro/Rev/Chg/ICN: ISWT-PDI-AUF1/0/0/1,2	Examination No.: ID-46
Project No.: 02-0285	Weld Description: Ring 3 Vert @ 356°	Device Configuration: D-PNPS-101	Surface Temperature °F
Mod.Conf.: A-07-1C	Scan Path Drawing: SPLONGSH2&3DS	Exam Date: 29-Apr-03	Start: 87
Data Acquisition Operator (s) / SNT Level: R.A. Riddles	/ II	Examination Time	End: 78
		Start: 0116	End: 0121

Scan Controller Parameters				Increment Axis/Device			Scan Axis/Arms			Positional Parameters	
				Planned	Actual	Planned	Actual				
Controller:	ID Device	Lower Limit	46776	50533	Lower Limit	69830	69830	Beam Direction:	Ccw/Cw		
Scan:	X Axis	Upper Limit	51276	51296	Upper Limit	71330	71330	Transducer Size:	1.00		
Increment:	Y Axis	Increment Interval	90			DCI	4			Code % of Overlap:	10
Mode:	Manual Scan	Conversion Counts	100			Conversion Counts	100			Number of Scans:	51
Scan Motion:	Bi-directional	Conversion Units In.	1.00			Conversion Units In.	1.00			Device Position:	A (180)
Correction:	Default	EDAS Radius In.	113.60								

Module Parameters: A-07-1C Cal 33						Calibration Records:	Examination Notes:
Channel	Status	Angle	Direction	Scan Offset	Step Offset	PNS-33	
Channel 1	On	55	(+)	- 7.00(in)	+ 0.00(in)	80331	Check for limitations due to the proximity of the feedwater and core spray spargers and the guide rod.
Channel 2	On	55	(-)	+ 7.00(in)	+ 0.00(in)	80332	
Channel 3	On	SLIC-40	(+)	- 4.40(in)	- 1.00(in)	80333	Examination Remarks: Limited exam due to proximity of core spray sparger.
Channel 4	On	SLIC-40	(-)	+ 4.40(in)	+ 1.00(in)	80334	
Channel 5	On	0T	(+)	- 4.40(in)	+ 1.00(in)	80335	
Channel 6	On	0T	(+)	+ 4.40(in)	- 1.00(in)	80336	
Channel 7	Off	N/A	N/A	N/A	N/A	N/A	
Channel 8	Off	N/A	N/A	N/A	N/A	N/A	

Increment & Scan Positions Actual					Recordable Indications			Analyst Remarks	
Scan No.(s)	Increment Position		Scan Position		Yes	No	N/A	Attachment: <input type="checkbox"/> Yes <input checked="" type="checkbox"/> No	
	Start	Stop	Start	Stop					
43 - 51	50617	51281	69830	71330	Channel 1 <input type="checkbox"/>	Channel 2 <input checked="" type="checkbox"/>	Channel 3 <input type="checkbox"/>	Channel 6 inactive.	
					Channel 4 <input type="checkbox"/>	Channel 5 <input checked="" type="checkbox"/>	Channel 6 <input checked="" type="checkbox"/>	Further Evaluation Required: <input type="checkbox"/> Yes <input checked="" type="checkbox"/> No	
					Channel 7 <input type="checkbox"/>	Channel 8 <input type="checkbox"/>		Archive Tape/CD No.: 4A	
								Analysis Tape/CD No.: 1A	

Analyst / SNT Level / Date:
Hector Diaz

Hector Diaz

III

29-Apr-03

Page 63/140

ISWT EXAMINATION SUMMARY RECORD

Project No.: 02-0285

PILGRIM NUCLEAR POWER STATION

Summary Sheet No.: 000800

SITE: PILGRIM STATION
SYSTEM: REACTOR PRESSURE VESSEL
LINE/SUBASSEMBLY: RING 3 VERTICAL WELD @ 116-DEGREES
IDENTIFICATION: RPV-L-2-339B

NDE Method	Proc/Rev/Chg/ICN	NDE Examination	Calibration Sheet No.	Data Sheet No.	N O R T I H	Resolution Record	CNF Number	Remarks
AUT	ISWT-PDI-AUT1/0/0/1,2	AUTO	80335,80336	exam 51-54	X -	N/A	N/A	Examination no's 47-54.
AUT	ISWT-PDI-AUT1/0/0/1,2	AUT55	80331,80332	exam 51-54	X -	N/A	N/A	AUTO for thickness measurement only.
AUT	ISWT-PDI-AUT1/0/0/1,2	AUTSLIC40	80333,80334	exam 51-54	X -	N/A	N/A	
AUT	ISWT-PDI-AUT1/0/0/1,2	AUT55T	80031,80032	exam 47-50	X -	N/A	N/A	
AUT	ISWT-PDI-AUT1/0/0/1,2	AUTSLIC40T	80033,80034	exam 47-50	X -	N/A	N/A	
AUT	ISWT-PDI-AUT1/0/0/1,2	AUTO	80035	exam 47-50	X -	N/A	N/A	

- NOTES:**
1. Weld RPV-L-2-339B was examined from the inside surface using AIRIS-21 and EDAS-II examination equipment.
 2. No recordable indications were detected during this examination.
 3. The examination was limited due to proximity of feedwater and core spray spargers and ID taper at circ weld C-3-339A, 75% examination coverage was achieved. ID taper configuration in this area was greater (more severe) than experienced for welds RPV-L-2-339A and RPV-L-2-339C, resulting in slightly less examination coverage on this weld.

****UT CALIBRATION BLOCK(S)****
 D-70187-2/D70300.1

Prepared by: Steven J. Todd
 Steven J. Todd - Project Engineer

Date: 2 July 2003

Page 1 of 1

Summary Sheet No.: 000800

Page 65/140



IHI SOUTHWEST TECHNOLOGIES AUTOMATED ULTRASONIC EXAMINATION RECORD

Site/Plant : Pilgrim Station	Weld Identification: RPV-L-2-339B	Pro/Rev/Chg/ICN: ISWT-PDI-AUT/1/0/0/1,2	Examination No.: ID-47
Project No.: 02-0285	Weld Description: Ring 3 Vert @ 116°	Device Configuration: D-PNPS-102	
Mod.Conf.: A-07B	Scan Path Drawing: SPLONGSH2&3DS	Exam Date: 28-Apr-03	Surface Temperature °F
Data Acquisition Operator (s) / SNT Level: R.A. Riddles / II		Examination Time	
		Start: 2006	End: 2019
		Start: 87	End: 87

Scan Controller Parameters		Increment Axis/Arm	Planned	Actual	Scan Axis/Device	Planned	Actual	Positional Parameters	
Controller:	ID Device	Lower Limit	22368	22348	Lower Limit	38750	38750	Beam Direction:	Dn/Up
Scan:	Y Axis	Upper Limit	23628	23615	Upper Limit	42814	42402	Transducer Size:	1.00
Increment:	X Axis	Increment Interval	90		DCI	4		Gate % of Overlap:	10
Mode:	Automatic Scan	Conversion Counts	100		Conversion Counts	100		Number of Scans:	15
Scan Motion:	Bi-directional	Conversion Units In.	1.00		Conversion Units In.	1.00		Device Position:	D (0)
Correction:	Default	EDAS Radius In.	113.60						

Module Parameters: A-07B Cal 03						Calibration Records:	Examination Notes:
Status	Angle	Direction	Scan Offset	Step Offset		PNS-03	Check for limitations due to the proximity of the feedwater and core spray spargers. Examination Remarks: Limited exam due to proximity of core spray sparge.
Channel 1	On	55 (-)	- 1.40(in)	- 1.21(in)		80031	
Channel 2	On	55 (+)	+ 1.40(in)	- 1.21(in)		80032	
Channel 3	On	SLIC-40 (-)	- 1.97(in)	+ 1.69(in)		80033	
Channel 4	On	SLIC-40 (+)	+ 1.97(in)	+ 1.69(in)		80034	
Channel 5	On	0T (+)	+ 0.00(in)	+ 1.69(in)		80035	
Channel 6	Off	N/A	N/A	N/A		N/A	
Channel 7	Off	N/A	N/A	N/A		N/A	
Channel 8	Off	N/A	N/A	N/A		N/A	

Scan No.(s)	Increment & Scan Positions Actual				Recordable Indications			Analyst Remarks	
	Increment Position		Scan Position		Yes	No	N/A	Attachment:	
	Start	Stop	Start	Stop					
1 - 11	22376	23144	38750	42402	<input type="checkbox"/>	<input checked="" type="checkbox"/>	<input type="checkbox"/>	<input type="checkbox"/> Yes <input checked="" type="checkbox"/> No	
12	23317	-	39434	42402	<input type="checkbox"/>	<input checked="" type="checkbox"/>	<input type="checkbox"/>		
13 - 15	23481	33628	39674	42402	<input type="checkbox"/>	<input checked="" type="checkbox"/>	<input type="checkbox"/>	Archive Tape/CD No.: 4AA	
					<input type="checkbox"/>	<input checked="" type="checkbox"/>	<input type="checkbox"/>		
					<input type="checkbox"/>	<input type="checkbox"/>	<input checked="" type="checkbox"/>		
					<input type="checkbox"/>	<input type="checkbox"/>	<input checked="" type="checkbox"/>		
					<input type="checkbox"/>	<input type="checkbox"/>	<input checked="" type="checkbox"/>		

Analyst / SNT Level / Date:
Hector Diaz *Hector Diaz* III 29-Apr-03

Page 66/140



IHI SOUTHWEST TECHNOLOGIES AUTOMATED ULTRASONIC EXAMINATION RECORD

Site/Plant: Pilgrim Station	Weld Identification: RPV-L-2-339B	Pro/Rev/Chg/ICN: ISwT-PDI-AUT1/0/0/1,2	Examination No.: ID-48
Project No.: 02-0285	Weld Description: Ring 3 Vert @ 116°	Device Configuration: D-PNPS-102	
Mod.Conf.: A-07A	Scan Path Drawing: SPLONGSH2&3DS	Exam Date: 28-Apr-03	Surface Temperature °F:
Data Acquisition Operator (s) / SNT Level: R.A. Riddles / II		Examination Time:	Start: 87, End: 87
		Start: 2028, End: 2036	

Scan Controller Parameters		Increment Axis/Arm	Planned	Actual	Scan Axis/Device	Planned	Actual	Positional Parameters	
Controller:	ID Device	Lower Limit	22368	22348	Lower Limit	42763	42400	Beam Direction:	Up/Dn
Scan:	Y Axis	Upper Limit	23628	23628	Upper Limit	46827	44800	Transducer Size:	1.00
Increment:	X Axis	Increment Interval	90		DCI	4		Code % of Overlap:	10
Mode:	Automatic Scan	Conversion Counts	100		Conversion Counts	100		Number of Scans:	15
Scan Motion:	Bi-directional	Conversion Units In.	1.00		Conversion Units In.	1.00		Device Position:	D (180)
Correction:	Default	EDAS Radius In.	113.60						

Module Parameters:						Calibration Records:	Examination Notes:
A-07A		Cal 03				PNS-03	Check for limitations due to the proximity of the feedwater and core spray spargers.
Status	Angle	Direction	Scan Offset	Step Offset		80031	
Channel 1	On	55	(+)	+ 1.40(in)	+ 1.21(in)	80032	
Channel 2	On	55	(-)	- 1.40(in)	+ 1.21(in)	80033	
Channel 3	On	SLIC-40	(+)	+ 1.97(in)	- 1.69(in)	80034	
Channel 4	On	SLIC-40	(-)	- 1.97(in)	- 1.69(in)	80035	
Channel 5	On	0T	(+)	+ 0.00(in)	- 1.69(in)	N/A	
Channel 6	Off	N/A	N/A	N/A	N/A	N/A	
Channel 7	Off	N/A	N/A	N/A	N/A	N/A	
Channel 8	Off	N/A	N/A	N/A	N/A	N/A	

Increment & Scan Positions Actual					Recordable Indications			Analyst Remarks	
Scan No.(s)	Increment Position		Scan Position		Yes	No	N/A	Attachment: <input type="checkbox"/> Yes <input checked="" type="checkbox"/> No	Further Evaluation Required: <input type="checkbox"/> Yes <input checked="" type="checkbox"/> No
	Start	Stop	Start	Stop					
1 - 15	22368	23628	42390	44815	<input type="checkbox"/>	<input checked="" type="checkbox"/>	<input type="checkbox"/>	Archive Tape/CD No.: 4AA Analysis Tape/CD No.: 1A	
					<input type="checkbox"/>	<input checked="" type="checkbox"/>	<input type="checkbox"/>		
					<input type="checkbox"/>	<input checked="" type="checkbox"/>	<input type="checkbox"/>		
					<input type="checkbox"/>	<input checked="" type="checkbox"/>	<input type="checkbox"/>		
					<input type="checkbox"/>	<input checked="" type="checkbox"/>	<input type="checkbox"/>		
					<input type="checkbox"/>	<input type="checkbox"/>	<input checked="" type="checkbox"/>		
					<input type="checkbox"/>	<input type="checkbox"/>	<input checked="" type="checkbox"/>		
					<input type="checkbox"/>	<input type="checkbox"/>	<input checked="" type="checkbox"/>		

Analyst / SNT Level / Date:
Hector Diaz *Hector Diaz* III 29-Apr-03

Page 67/140



IHI SOUTHWEST TECHNOLOGIES AUTOMATED ULTRASONIC EXAMINATION RECORD

Site/Plant: Pilgrim Station	Weld Identification: RPV-L-2-339B	Pro/Rev/Chg/ICN: ISwT-PDI-AUT1/0/0/1,2	Examination No.: ID-49
Project No.: 02-0285	Weld Description: Ring 3 Vert @ 116°	Device Configuration: D-PNPS-102	
Mod.Conf.: A-07B	Scan Path Drawing: SPLONGSH2&3DS	Exam Date: 28-Apr-03	Surface Temperature °F
Data Acquisition Operator (s) / SNT Level: Steven J. Todd / III		Examination Time	Start End
		1810 1919	96 96

Scan Controller Parameters		Increment Axis/Arm	Planned	Actual	Scan Axis/Device	Planned	Actual	Positional Parameters	
Controller:	ID Device	Lower Limit	22368	22368	Lower Limit	46776	47550	Beam Direction:	Dn/Up
Scan:	Y Axis	Upper Limit	23628	23628	Upper Limit	52096	48350	Transducer Size:	1.00
Increment:	X Axis	Increment Interval	90		DCI	4		Code % of Overlap:	10
Mode:	Automatic Scan	Conversion Counts	100		Conversion Counts	100		Number of Scans:	15
Scan Motion:	Bi-directional	Conversion Units In.	1.00		Conversion Units In.	1.00		Device Position:	D (0)
Correction:	Default	EDAS Radius In.	113.60						

Module Parameters: A-07B Cal 03						Calibration Records:	Examination Notes:
Channel	Status	Angle	Direction	Scan Offset	Step Offset		
Channel 1	On	55	(-)	- 1.40(in)	- 1.21(in)	PNS-03	Check for limitations due to the proximity of the feedwater and core spray spargers.
Channel 2	On	55	(+)	+ 1.40(in)	- 1.21(in)	80031	
Channel 3	On	SLIC-40	(-)	- 1.97(in)	+ 1.69(in)	80032	
Channel 4	On	SLIC-40	(+)	+ 1.97(in)	+ 1.69(in)	80033	
Channel 5	On	0T	(+)	+ 0.00(in)	+ 1.69(in)	80034	Examination Remarks: Limited exnm due to proximity of core spray, feedwater spargers and ID taper on weld RPV-C-3-339A.
Channel 6	Off	N/A	N/A	N/A	N/A	80035	
Channel 7	Off	N/A	N/A	N/A	N/A	N/A	
Channel 8	Off	N/A	N/A	N/A	N/A	N/A	

Scan No.(s)	Increment & Scan Positions Actual				Recordable Indications			Analyst Remarks	
	Increment Position		Scan Position		Yes	No	N/A	Attachment: <input type="checkbox"/> Yes <input checked="" type="checkbox"/> No	
	Start	Stop	Start	Stop	Channel 1	Channel 2	Channel 3		
1 - 15	22343	23549	47550	48350	<input type="checkbox"/>	<input checked="" type="checkbox"/>	<input type="checkbox"/>	Further Evaluation Required: <input type="checkbox"/> Yes <input checked="" type="checkbox"/> No Archive Tape/CD No.: 4AA Analysis Tape/CD No.: 1A	
					<input type="checkbox"/>	<input checked="" type="checkbox"/>	<input type="checkbox"/>		
					<input type="checkbox"/>	<input checked="" type="checkbox"/>	<input type="checkbox"/>		
					<input type="checkbox"/>	<input checked="" type="checkbox"/>	<input type="checkbox"/>		
					<input type="checkbox"/>	<input checked="" type="checkbox"/>	<input type="checkbox"/>		
					<input type="checkbox"/>	<input type="checkbox"/>	<input checked="" type="checkbox"/>		
					<input type="checkbox"/>	<input type="checkbox"/>	<input checked="" type="checkbox"/>		
					<input type="checkbox"/>	<input type="checkbox"/>	<input checked="" type="checkbox"/>		

Analyst / SNT Level / Date: Hector Diaz	III	29-Apr-03
--	-----	-----------

Page 68/140



IHI SOUTHWEST TECHNOLOGIES AUTOMATED ULTRASONIC EXAMINATION RECORD

Site/Plant : Pilgrim Station	Weld Identification: RPV-L-2-339B	Pro/Rev/Chg/ICN: ISWT-PDI-AUT1/0/0/1,2	Examination No.: ID-50
Project No.: 02-0285	Weld Description: Ring 3 Vert @ 116°	Device Configuration: D-PNPS-102	
Mod.Conf.: A-07A	Scan Path Drawing: SPLONGSH2&3DS	Exam Date: 28-Apr-03	Surface Temperature °F
Data Acquisition Operator (s) / SNT Level: R.A. Riddles / II		Examination Time	Start End Start End
		1730 1810	96 96

Scan Controller Parameters	Increment Axis/Arm	Planned	Actual	Scan Axis/Device	Planned	Actual	Positional Parameters
Controller: ID Device	Lower Limit	22368	22345	Lower Limit	46776	50300	Beam Direction: Up/Dn
Scan: Y Axis	Upper Limit	23628	23591	Upper Limit	52096	52092	Transducer Size: 1.00
Increment: X Axis	Increment Interval	90		DCI	4		Code % of Overlap: 10
Mode: Automatic Scan	Conversion Counts	100		Conversion Counts	100		Number of Scans: 15
Scan Motion: Bi-directional	Conversion Units In.	1.00		Conversion Units In.	1.00		Device Position: D (180)
Correction: Default	EDAS Radius In.	113.60					

Module Parameters: A-07A Cal 03						Calibration Records:	Examination Notes:
Status	Angle	Direction	Scan Offset	Step Offset		PNS-03	Check for limitations due to the proximity of the feedwater and core spray spargers.
Channel 1	On	55	(+)	+ 1.40(in)	+ 1.21(in)	80031	
Channel 2	On	55	(-)	- 1.40(in)	+ 1.21(in)	80032	
Channel 3	On	SLIC-40	(+)	+ 1.97(in)	- 1.69(in)	80033	
Channel 4	On	SLIC-40	(-)	- 1.97(in)	- 1.69(in)	80034	
Channel 5	On	0T	(+)	+ 0.00(in)	- 1.69(in)	80035	
Channel 6	Off	N/A	N/A	N/A	N/A	N/A	
Channel 7	Off	N/A	N/A	N/A	N/A	N/A	
Channel 8	Off	N/A	N/A	N/A	N/A	N/A	

Scan No.(s)	Increment & Scan Positions Actual				Recordable Indications			Analyst Remarks	
	Start	Stop	Start	Stop	Yes	No	N/A	Attachment:	
1 - 15	22368	23628	50300	52096	Channel 1 <input type="checkbox"/>	Channel 2 <input checked="" type="checkbox"/>	Channel 3 <input type="checkbox"/>	<input type="checkbox"/> Yes <input checked="" type="checkbox"/> No	
					Channel 4 <input type="checkbox"/>	Channel 5 <input checked="" type="checkbox"/>	Channel 6 <input type="checkbox"/>	Further Evaluation	
					Channel 7 <input type="checkbox"/>	Channel 8 <input checked="" type="checkbox"/>		Required:	
								<input type="checkbox"/> Yes <input checked="" type="checkbox"/> No	
								Archive Tape/CD No.:	
								4AA	
								Analysis Tape/CD No.:	
								1A	

Analyst / SNT Level / Date:
Hector Diaz *Hector Diaz* III 29-Apr-03

Page 69/70



IHI SOUTHWEST TECHNOLOGIES AUTOMATED ULTRASONIC EXAMINATION RECORD

Site/Plant : Pilgrim Station	Weld Identification: RPV-L-2-339B	Pro/Rev/Chg/ICN: ISWT-PDI-AUT1/0/0/1,2	Examination No.: ID-51
Project No.: 02-0285	Weld Description: Ring 3 Vert @ 116°	Device Configuration: D-PNPS-101	
Mod.Conf.: A-07-1D	Scan Path Drawing: SPLONGSH2&3DS	Exam Date: 27-Apr-03	Surface Temperature °C
Data Acquisition Operator (s) / SNT Level: R.A. Riddles	/ II	Examination Time	Start End Start End
		2027 2102	96 96

Scan Controller Parameters		Increment Axis/Arm	Planned	Actual	Scan Axis/Device	Planned	Actual	Positional Parameters	
Controller:	ID Device	Lower Limit	39650	39637	Lower Limit	22248	22248	Beam Direction:	Ccw/Cw
Scan:	X Axis	Upper Limit	43340	40783	Upper Limit	23748	23748	Transducer Size:	1.00
Increment:	Y Axis	Increment Interval	90		DCI	4		Code % of Overlap:	10
Mode:	Automatic Scan	Conversion Counts	100		Conversion Counts	100		Number of Scans:	42
Scan Motion:	Bi-directional	Conversion Units In.	1.00		Conversion Units In.	1.00		Device Position:	A (0)
Correction:	Default	EDAS Radius In.	113.60						

Module Parameters:						Cal 33	Calibration Records:	Examination Notes:
Channel	Status	Angle	Direction	Scan Offset	Step Offset			
Channel 1	On	55	(-)	+ 7.00(in)	+ 0.00(in)	PNS-33	Check for limitations due to the proximity of the feedwater and core spray spargers.	
Channel 2	On	55	(+)	- 7.00(in)	+ 0.00(in)	R0331		
Channel 3	On	SLIC-40	(-)	+ 4.40(in)	+ 1.00(in)	R0332		
Channel 4	On	SLIC-40	(+)	- 4.40(in)	- 1.00(in)	R0333		
Channel 5	On	0T	(+)	+ 4.40(in)	- 1.00(in)	R0334		
Channel 6	On	0T	(+)	- 4.40(in)	+ 1.00(in)	R0335		
Channel 7	Off	N/A	N/A	N/A	N/A	R0336		
Channel 8	Off	N/A	N/A	N/A	N/A	N/A		

Increment & Scan Positions Actual					Recordable Indications			Analyst Remarks	
Scan No.(s)	Increment Position		Scan Position		Yes	No	N/A	Attachment: <input type="checkbox"/> Yes <input checked="" type="checkbox"/> No	Channel 6 inactive.
	Start	Stop	Start	Stop					
1 - 14	39666	40807	22248	23748	Channel 1 <input type="checkbox"/>	<input checked="" type="checkbox"/>	<input type="checkbox"/>	Further Evaluation Required: <input type="checkbox"/> Yes <input checked="" type="checkbox"/> No Archive Tape/CD No.: 3A Analysis Tape/CD No.: 1A	
					Channel 2 <input type="checkbox"/>	<input checked="" type="checkbox"/>	<input type="checkbox"/>		
					Channel 3 <input type="checkbox"/>	<input checked="" type="checkbox"/>	<input type="checkbox"/>		
					Channel 4 <input type="checkbox"/>	<input checked="" type="checkbox"/>	<input type="checkbox"/>		
					Channel 5 <input type="checkbox"/>	<input checked="" type="checkbox"/>	<input type="checkbox"/>		
					Channel 6 <input type="checkbox"/>	<input type="checkbox"/>	<input checked="" type="checkbox"/>		
					Channel 7 <input type="checkbox"/>	<input type="checkbox"/>	<input checked="" type="checkbox"/>		
					Channel 8 <input type="checkbox"/>	<input type="checkbox"/>	<input checked="" type="checkbox"/>		

Analyst / SNT Level / Date:
Hector Diaz *Hector Diaz* III 29-Apr-03

Page 70/240



IHI SOUTHWEST TECHNOLOGIES AUTOMATED ULTRASONIC EXAMINATION RECORD

Site/Plant: Pilgrim Station	Weld Identification: RPV-L-2-339B	Pro/Rev/Chg/ICN: ISWT-PDI-AUT1/0/0/1,2	Examination No.: ID-52
Project No.: 02-0285	Weld Description: Ring 3 Vert @ 116°	Device Configuration: D-PNPS-101	
Mod.Conf.: A-07-1C	Scan Path Drawing: SPLONGSH2&3DS	Exam Date: 27-Apr-03	Surface Temperature °F:
Data Acquisition Operator (s) / SNT Level: R.A. Riddles / II		Examination Time:	Start / End
		Start: 2118	End: 2251
		Start: 96	End: 96

Scan Controller Parameters				Increment Axis/Arm			Scan Axis/Device			Positional Parameters	
Controller:	ID Device	Lower Limit	Planned: 43213	Actual: 40820	Lower Limit	Planned: 22248	Actual: 22248	Beam Direction:	Cw/Ccw		
Scan:	X Axis	Upper Limit	Planned: 46903	Actual: 45017	Upper Limit	Planned: 23748	Actual: 23748	Transducer Size:		1.00	
Increment:	Y Axis	Increment Interval	90			DCI	4		Code % of Overlap:		10
Mode:	Automatic Scan	Conversion Counts	100			Conversion Counts	100		Number of Scans:		42
Scan Motion:	Bi-directional	Conversion Units In.	1.00			Conversion Units In.	1.00		Device Position:		A (180)
Correction:	Default	EDAS Radius In.	113.60								

Module Parameters: A-07-1C Cal 33						Calibration Records:		Examination Notes:	
Channel	Status	Angle	Direction	Scan Offset	Step Offset	FNS-33		Check for limitations due to the proximity of the feedwater and core spray spargers.	
Channel 1	On	55	(+)	- 7.00(in)	+ 0.00(in)	80331			
Channel 2	On	55	(-)	+ 7.00(in)	+ 0.00(in)	80332			
Channel 3	On	SLIC-40	(+)	- 4.40(in)	- 1.00(in)	80333			
Channel 4	On	SLIC-40	(-)	+ 4.40(in)	+ 1.00(in)	80334		Examination Remarks:	
Channel 5	On	0T	(+)	- 4.40(in)	+ 1.00(in)	80335		Limited exam due to proximity of the Core Spray Sparger.	
Channel 6	On	0T	(+)	+ 4.40(in)	- 1.00(in)	80336			
Channel 7	Off	N/A	N/A	N/A	N/A	N/A			
Channel 8	Off	N/A	N/A	N/A	N/A	N/A			

Increment & Scan Positions Actual					Recordable Indications			Analyst Remarks	
Scan No.(s)	Increment Position		Scan Position		Yes	No	N/A	Attachment:	
	Start	Stop	Start	Stop				<input type="checkbox"/> Yes <input checked="" type="checkbox"/> No	
1 - 50	40795	45017	22248	23748	Channel 1 <input type="checkbox"/>	<input checked="" type="checkbox"/>	<input type="checkbox"/>	Channel 6 inactive.	
					Channel 2 <input type="checkbox"/>	<input checked="" type="checkbox"/>	<input type="checkbox"/>	Further Evaluation	
					Channel 3 <input type="checkbox"/>	<input checked="" type="checkbox"/>	<input type="checkbox"/>	Required:	
					Channel 4 <input type="checkbox"/>	<input checked="" type="checkbox"/>	<input type="checkbox"/>	<input type="checkbox"/> Yes <input checked="" type="checkbox"/> No	
					Channel 5 <input type="checkbox"/>	<input checked="" type="checkbox"/>	<input type="checkbox"/>	Archive Tape/CD No.:	
					Channel 6 <input type="checkbox"/>	<input type="checkbox"/>	<input checked="" type="checkbox"/>	3A	
					Channel 7 <input type="checkbox"/>	<input type="checkbox"/>	<input checked="" type="checkbox"/>	Analysis Tape/CD No.:	
					Channel 8 <input type="checkbox"/>	<input type="checkbox"/>	<input checked="" type="checkbox"/>	1A	

Analyst / SNT Level / Date: Hector Diaz / III / 29-Apr-03

Page 7/1/240



IHI SOUTHWEST TECHNOLOGIES AUTOMATED ULTRASONIC EXAMINATION RECORD

Site/Plant : Pilgrim Station	Weld Identification: RPV-L-2-339B	Pro/Rev/Chg/ICN: ISwT-PDI-AUT1/0/0/1,2	Examination No.: ID-53
Project No.: 02-0285	Weld Description: Ring 3 Vert @ 116°	Device Configuration: D-PNPS-101	
Mod.Conf.: A-07-1D	Scan Path Drawing: SPLONGSH2&3DS	Exam Date: 27-Apr-03	Surface Temperature °F
Data Acquisition Operator (s) / SNT Level: Harper Jacoby / N/A		Start: 1844	End: 1905
		Start: 96	End: 96

Scan Controller Parameters		Increment Axis/Device		Planned	Actual	Scan Axis/Arm		Planned	Actual	Positional Parameters	
Controller:	ID Device	Lower Limit	46776	47465	Lower Limit	22248	22248	Beam Direction:	Ccw/Cw	Transducer Size: 1.00	
Scan:	X Axis	Upper Limit	51186	50037	Upper Limit	23748	23748	Code % of Overlap:	10	Number of Scans: 50	
Increment:	Y Axis	Increment Interval	90		DCI	4		Device Position:	A (0)		
Mode:	Automatic Scan	Conversion Counts	100		Conversion Counts	100					
Scan Motion:	Bi-directional	Conversion Units In.	1.00		Conversion Units In.	1.00					
Correction:	Default	EDAS Radius In.	113.60								

Module Parameters: A-07-1D Cal 33						Calibration Records:	Examination Notes:
Channel	Status	Angle	Direction	Scan Offset	Step Offset	FNS-33	Check for limitations due to the proximity of the feedwater and core spray spargers. Examination Remarks: Limited exam due to proximity of the Core Spray Sparger.
Channel 1	On	55	(-)	+ 7.00(in)	+ 0.00(in)	80331	
Channel 2	On	55	(+)	- 7.00(in)	+ 0.00(in)	80332	
Channel 3	On	SLIC-40	(-)	+ 4.40(in)	+ 1.00(in)	80333	
Channel 4	On	SLIC-40	(+)	- 4.40(in)	- 1.00(in)	80334	
Channel 5	On	0T	(+)	+ 4.40(in)	- 1.00(in)	80335	
Channel 6	On	0T	(+)	- 4.40(in)	+ 1.00(in)	80336	
Channel 7	Off	N/A	N/A	N/A	N/A	N/A	
Channel 8	Off	N/A	N/A	N/A	N/A	N/A	

Scan No.(s)	Increment & Scan Positions Actual				Recordable Indications			Analyst Remarks	
	Increment Position		Scan Position		Yes	No	N/A	Attachment: <input type="checkbox"/> Yes <input checked="" type="checkbox"/> No	Further Evaluation Required: <input type="checkbox"/> Yes <input checked="" type="checkbox"/> No
	Start	Stop	Start	Stop	Channel 1	Channel 2	Channel 3		
9-37	47468	50016	22248	23725	<input type="checkbox"/>	<input checked="" type="checkbox"/>	<input type="checkbox"/>	Archive Tape/CD No.: 3A	
					Channel 4	Channel 5	Channel 6	Analysis Tape/CD No.: 1A	
					Channel 7	Channel 8			

Analyst / SNT Level / Date:
Hector Diaz *Hector Diaz* III 29-Apr-03

Page 72/140



IHI SOUTHWEST TECHNOLOGIES AUTOMATED ULTRASONIC EXAMINATION RECORD

Site/Plant: Pilgrim Station	Weld Identification: RPV-L-2-339B	Pro/Rev/Chg/ICN: ISwT-PDI-AUT1/0/0/1,2	Examination No.: ID-54
Project No.: 02-0285	Weld Description: Ring 3 Vert @ 116°	Device Configuration: D-PNPS-101	
Mod.Conf.: A-07-1C	Scan Path Drawing: SPLONGSH2&3DS	Exam Date: 27-Apr-03	Surface Temperature °F
Data Acquisition Operator (s) / SNT Level: Harper Jacoby / N/A		Examination Time	Start End
		1820 1825	96 96

Scan Controller Parameters				Increment Axis/Device			Scan Axis/Arm			Positional Parameters	
				Planned	Actual	Planned		Actual			
Controller:	ID Device			Lower Limit	46776	49824	Lower Limit	22248	22248	Beam Direction:	Cw/Ccv
Scan:	X Axis			Upper Limit	51186	51194	Upper Limit	23748	23748	Transducer Size:	1.00
Increment:	Y Axis			Increment Interval	90		DCI	4		Code % of Overlap:	10
Mode:	Automatic Scan			Conversion Counts	100		Conversion Counts	100		Number of Scans:	50
Scan Motion:	Bi-directional			Conversion Units In.	1.00		Conversion Units In.	1.00		Device Position:	A (180)
Correction:	Default			EDAS Radius In.	113.60						

Module Parameters: A-07-1C Cal 33						Calibration Records:		Examination Notes:	
	Status	Angle	Direction	Scan Offset	Step Offset	PNS-33			
Channel 1	On	55	(+)	- 7.00(in)	+ 0.00(in)	80331		Check for limitations due to the proximity of the feedwater and core spray spargers.	
Channel 2	On	55	(-)	+ 7.00(in)	+ 0.00(in)	80332			
Channel 3	On	SLIC-40	(+)	- 4.40(in)	- 1.00(in)	80333			
Channel 4	On	SLIC-40	(-)	+ 4.40(in)	+ 1.00(in)	80334		Examination Remarks:	
Channel 5	On	0T	(+)	- 4.40(in)	+ 1.00(in)	80335		Limited exam due to proximity of the Core Spray Sparger.	
Channel 6	On	0T	(+)	+ 4.40(in)	- 1.00(in)	80336			
Channel 7	Off	N/A	N/A	N/A	N/A	N/A			
Channel 8	Off	N/A	N/A	N/A	N/A	N/A			

Increment & Scan Positions Actual					Recordable Indications			Analyst Remarks	
Scan No.(s)	Increment Position		Scan Position		Yes	No	N/A	Attachment: <input type="checkbox"/> Yes <input checked="" type="checkbox"/> No	
	Start	Stop	Start	Stop					
35 - 50	49828	51186	22248	23748	Channel 1 <input type="checkbox"/>	<input checked="" type="checkbox"/>	<input type="checkbox"/>	Further Evaluation Required:	
					Channel 2 <input type="checkbox"/>	<input checked="" type="checkbox"/>	<input type="checkbox"/>	<input type="checkbox"/> Yes <input checked="" type="checkbox"/> No	
					Channel 3 <input type="checkbox"/>	<input checked="" type="checkbox"/>	<input type="checkbox"/>	Archive Tape/CD No.: 3A	
					Channel 4 <input type="checkbox"/>	<input checked="" type="checkbox"/>	<input type="checkbox"/>	Analysis Tape/CD No.: IA	
					Channel 5 <input type="checkbox"/>	<input checked="" type="checkbox"/>	<input type="checkbox"/>		
					Channel 6 <input type="checkbox"/>	<input checked="" type="checkbox"/>	<input type="checkbox"/>		
					Channel 7 <input type="checkbox"/>	<input type="checkbox"/>	<input checked="" type="checkbox"/>		
					Channel 8 <input type="checkbox"/>	<input type="checkbox"/>	<input checked="" type="checkbox"/>		

Analyst / SNT Level / Date: **Hector Diaz** *Hector Diaz* III 29-Apr-03

Page 73/140

Page 74/240

ISwT EXAMINATION SUMMARY RECORD

Project No.: 02-0285

PILGRIM NUCLEAR POWER STATION

Summary Sheet No.: 000900

SITE: PILGRIM STATION
SYSTEM: REACTOR PRESSURE VESSEL
LINE/SUBASSEMBLY: RING 3 VERTICAL WELD @ 236-DEGREES
IDENTIFICATION: RPV-L-2-339C

NDE Method	Proc/Rev/Chg/ICN	NDE Examination	Calibration Sheet No.	Data Sheet No.	N O		Resolution Record	CNF Number	Remarks
					I	H			
AUT	ISwT-PDI-AUT1/0/0/1,2	AUTO	80335,80336	exam 59-62	X	-	N/A	N/A	Examination no's 55-62.
AUT	ISwT-PDI-AUT1/0/0/1,2	AUT55	80331,80332	exam 59-62	X	-	N/A	N/A	AUTO for thickness measurement only.
AUT	ISwT-PDI-AUT1/0/0/1,2	AUTSLIC40	80333,80334	exam 59-62	X	-	N/A	N/A	
AUT	ISwT-PDI-AUT1/0/0/1,2	AUT55T	80031,80032	exam 55-58	X	-	N/A	N/A	
AUT	ISwT-PDI-AUT1/0/0/1,2	AUTSLIC40T	80033,80034	exam 55-58	X	-	N/A	N/A	
AUT	ISwT-PDI-AUT1/0/0/1,2	AUTO	80035	exam 55-58	X	-	N/A	N/A	

- NOTES:
1. Weld RPV-L-2-339C was examined from the inside surface using AIRIS-21 and EDAS-II examination equipment.
 2. No recordable indications were detected during this examination.
 3. The examination was limited due to proximity of feedwater and core spray spargers, 83% examination coverage was achieved.

****UT CALIBRATION BLOCK(s)****
 D-70187-2/D70389-1

Boop 7/5/14

Prepared by: Steven J. Todd
 Steven J. Todd - Project Engineer

Date: 04-May-03

Page 1 of 1



IHI SOUTHWEST TECHNOLOGIES AUTOMATED ULTRASONIC EXAMINATION RECORD

Site/Plant: Pilgrim Station	Weld Identification: RPV-L-2-339C	Pro/Rev/Chg/ICN: ISwT-PDI-AUT1/0/0/1,2	Examination No.: ID-55
Project No.: 02-0285	Weld Description: Ring 3 Vert @ 236°	Device Configuration: D-PNPS-102	Surface Temperature °F:
Mod.Conf.: A-07B	Scan Path Drawing: SPLONGSH2&3DS	Exam Date: 28-Apr-03	Start: 96
Data Acquisition Operator (s) / SNT Level: Harper Jacoby	/ N/A	Examination Time: Start: 1425 End: 1432	End: 96

Scan Controller Parameters		Increment Axis/Arm	Planned	Actual	Scan Axis/Device	Planned	Actual	Positional Parameters	
Controller:	ID Device	Lower Limit	46159	46160	Lower Limit	38750	38750	Beam Direction:	Dn/Up
Scan:	Y Axis	Upper Limit	47419	47380	Upper Limit	42814	40862	Transducer Size:	1.00
Increment:	X Axis	Increment Interval	90		DCI	4		Code % of Overlap:	10
Mode:	Automatic Scan	Conversion Counts	100		Conversion Counts	100		Number of Scans:	15
Scan Motion:	Bi-directional	Conversion Units In.	1.00		Conversion Units In.	1.00		Device Position:	D (0)
Correction:	Default	EDAS Radius In.	113.60						

Module Parameters: A-07B Cal 03						Calibration Records:	Examination Notes:
Status	Angle	Direction	Scan Offset	Step Offset		PNS-03	Check for limitations due to the proximity of the feedwater and core spray spargers.
Channel 1	On	55 (-)	- 1.40(in)	- 1.21(in)		80031	
Channel 2	On	55 (+)	+ 1.40(in)	- 1.21(in)		80032	
Channel 3	On	SLIC-40 (-)	- 1.97(in)	+ 1.69(in)		80033	
Channel 4	On	SLIC-40 (+)	+ 1.97(in)	+ 1.69(in)		80034	
Channel 5	On	0T (+)	+ 0.00(in)	+ 1.69(in)		80035	
Channel 6	Off	N/A	N/A	N/A		N/A	
Channel 7	Off	N/A	N/A	N/A		N/A	
Channel 8	Off	N/A	N/A	N/A		N/A	

Scan No.(s)	Increment & Scan Positions Actual				Recordable Indications			Analyst Remarks	
	Increment Position		Scan Position		Yes	No	N/A	Attachment:	
1 - 15	Start: 46146	Stop: 47392	Start: 38750	Stop: 40862	Channel 1 <input type="checkbox"/>	Channel 2 <input checked="" type="checkbox"/>	Channel 3 <input type="checkbox"/>	<input type="checkbox"/> Yes <input checked="" type="checkbox"/> No	
					Channel 4 <input type="checkbox"/>	Channel 5 <input checked="" type="checkbox"/>	Channel 6 <input type="checkbox"/>	Further Evaluation Required: <input type="checkbox"/> Yes <input checked="" type="checkbox"/> No	
					Channel 7 <input type="checkbox"/>	Channel 8 <input checked="" type="checkbox"/>		Archive Tape/CD No.: 3A	
								Analysis Tape/CD No.: 1A	

Analyst / SNT Level / Date:
Hector Diaz

Hector Diaz

III

29-Apr-03

Page 76/80



IH SOUTHWEST TECHNOLOGIES AUTOMATED ULTRASONIC EXAMINATION RECORD

Site/Plant : Pilgrim Station	Weld Identification: RPV-L-2-339C	Pro/Rev/Chg/ICN: ISwT-PDI-AUT1/0/0/1,2	Examination No.: ID-56
Project No.: 02-0285	Weld Description: Ring 3 Vert @ 236°	Device Configuration: D-PNPS-102	
Mod.Conf.: A-07A	Scan Path Drawing: SPLONGSH2&3DS	Exam Date: 28-Apr-03	Surface Temperature °F:
Data Acquisition Operator (s) / SNT Level: Harper Jacoby / N/A		Examination Time:	Start End
		Start End	Start End
		1324 1420	96 96

Scan Controller Parameters		Increment Axis/Arm	Planned	Actual	Scan Axis/Device	Planned	Actual	Positional Parameters	
Controller:	ID Device	Lower Limit	46159	46160	Lower Limit	42763	40763	Beam Direction:	Up/Dn
Scan:	Y Axis	Upper Limit	47419	47420	Upper Limit	46827	44795	Transducer Size:	1.00
Increment:	X Axis	Increment Interval	90		DCI	4		Code % of Overlap:	10
Mode:	Automatic Scan	Conversion Counts	100		Conversion Counts	100		Number of Scans:	15
Scan Motion:	Bi-directional	Conversion Units In.	1.00		Conversion Units In.	1.00		Device Position:	D (180)
Correction:	Default	EDAS Radius In.	113.60						

Module Parameters:						Calibration Records:	Examination Notes:
A-07A		Cal 03				PNS-03	Check for limitations due to the proximity of the feedwater and core spray spargers.
Status	Angle	Direction	Scan Offset	Step Offset	80031		
Channel 1	On	55	(+)	+ 1.40(in)	+ 1.21(in)	80032	
Channel 2	On	55	(-)	- 1.40(in)	+ 1.21(in)	80033	
Channel 3	On	SLIC-40	(+)	+ 1.97(in)	- 1.69(in)	80034	
Channel 4	On	SLIC-40	(-)	- 1.97(in)	- 1.69(in)	80035	
Channel 5	On	0T	(+)	+ 0.00(in)	- 1.69(in)		
Channel 6	Off	N/A	N/A	N/A	N/A		
Channel 7	Off	N/A	N/A	N/A	N/A		
Channel 8	Off	N/A	N/A	N/A	N/A		

Scan No.(s)	Increment & Scan Positions Actual				Recordable Indications			Attachment:	Analyst Remarks
	Increment Position		Scan Position		Yes	No	N/A		
1 - 15	Start	Stop	Start	Stop	Channel 1	<input type="checkbox"/>	<input checked="" type="checkbox"/>	<input type="checkbox"/>	<input type="checkbox"/> Yes <input checked="" type="checkbox"/> No Further Evaluation Required: <input type="checkbox"/> Yes <input checked="" type="checkbox"/> No Archive Tape/CD No.: 3A Analysis Tape/CD No.: 1A
	46159	47318	40763	44840	Channel 2	<input type="checkbox"/>	<input checked="" type="checkbox"/>	<input type="checkbox"/>	
					Channel 3	<input type="checkbox"/>	<input checked="" type="checkbox"/>	<input type="checkbox"/>	
					Channel 4	<input type="checkbox"/>	<input checked="" type="checkbox"/>	<input type="checkbox"/>	
					Channel 5	<input type="checkbox"/>	<input checked="" type="checkbox"/>	<input type="checkbox"/>	
					Channel 6	<input type="checkbox"/>	<input type="checkbox"/>	<input checked="" type="checkbox"/>	
					Channel 7	<input type="checkbox"/>	<input type="checkbox"/>	<input checked="" type="checkbox"/>	
					Channel 8	<input type="checkbox"/>	<input type="checkbox"/>	<input checked="" type="checkbox"/>	

Analyst / SNT Level / Date:
Hector Diaz *Hector Diaz* III 29-Apr-03

Page 77/170



IHI SOUTHWEST TECHNOLOGIES AUTOMATED ULTRASONIC EXAMINATION RECORD

Site/Plant: Pilgrim Station	Weld Identification: RPV-L-2-339C	Pro/Rev/Chg/ICN: ISWT-PDI-AUT1/0/0/1,2	Examination No.: ID-57
Project No.: 02-0285	Weld Description: Ring 3 Vert @ 236°	Device Configuration: D-PNPS-102	
Mod.Conf.: A-07B	Scan Path Drawing: SPLONGSH2&3DS	Exam Date: 28-Apr-03	Surface Temperature °F:
Data Acquisition Operator (s) / SNT Level: Harper Jacoby / N/A		Examination Time:	
		Start: 1552	End: 1611
		Start: 96	End: 96

Scan Controller Parameters		Increment Axis/Arm	Planned	Actual	Scan Axis/Device	Planned	Actual	Positional Parameters	
Controller:	ID Device	Lower Limit	46159	46146	Lower Limit	46776	47550	Beam Direction:	Dn/Up
Scan:	Y Axis	Upper Limit	47419	47420	Upper Limit	52096	50402	Transducer Size:	1.00
Increment:	X Axis	Increment Interval	90		DCI	4		Code % of Overlap:	10
Mode:	Automatic Scan	Conversion Counts	100		Conversion Counts	100		Number of Scans:	15
Scan Motion:	Bi-directional	Conversion Units In.	1.00		Conversion Units In.	1.00		Device Position:	D (0)
Correction:	Default	EDAS Radius In.	113.60						

Module Parameters:						Calibration Records:	Examination Notes:
Status	Angle	Direction	Scan Offset	Step Offset			
Channel 1	On	55	(-)	- 1.40(in)	- 1.21(in)	PNS-03	Check for limitations due to the proximity of the feedwater and core spray spargers.
Channel 2	On	55	(+)	+ 1.40(in)	- 1.21(in)	80031	
Channel 3	On	SLIC-40	(-)	- 1.97(in)	+ 1.69(in)	80032	
Channel 4	On	SLIC-40	(+)	+ 1.97(in)	+ 1.69(in)	80033	
Channel 5	On	0T	(+)	+ 0.00(in)	+ 1.69(in)	80034	Examination Remarks: Limited exam due to proximity of core spray sparger.
Channel 6	Off	N/A	N/A	N/A	N/A	80035	
Channel 7	Off	N/A	N/A	N/A	N/A	N/A	
Channel 8	Off	N/A	N/A	N/A	N/A	N/A	

Scan No.(s)	Increment & Scan Positions Actual				Recordable Indications			Analyst Remarks	
	Increment Position		Scan Position		Yes	No	N/A	Attachment:	
	Start	Stop	Start	Stop	Channel 1	<input type="checkbox"/>	<input checked="" type="checkbox"/>	<input type="checkbox"/>	<input type="checkbox"/> Yes <input checked="" type="checkbox"/> No
1 - 15	46159	47414	47550	50402	Channel 2	<input type="checkbox"/>	<input checked="" type="checkbox"/>	<input type="checkbox"/>	Further Evaluation Required: <input type="checkbox"/> Yes <input checked="" type="checkbox"/> No Archive Tape/CD No.: 3A Analysis Tape/CD No.: 1A
					Channel 3	<input type="checkbox"/>	<input checked="" type="checkbox"/>	<input type="checkbox"/>	
					Channel 4	<input type="checkbox"/>	<input checked="" type="checkbox"/>	<input type="checkbox"/>	
					Channel 5	<input type="checkbox"/>	<input checked="" type="checkbox"/>	<input type="checkbox"/>	
					Channel 6	<input type="checkbox"/>	<input type="checkbox"/>	<input checked="" type="checkbox"/>	
					Channel 7	<input type="checkbox"/>	<input type="checkbox"/>	<input checked="" type="checkbox"/>	
					Channel 8	<input type="checkbox"/>	<input type="checkbox"/>	<input checked="" type="checkbox"/>	

Analyst / SNT Level / Date:
Hector Diaz

Hector Diaz

III

29-Apr-03

Page 78/140



IHI SOUTHWEST TECHNOLOGIES AUTOMATED ULTRASONIC EXAMINATION RECORD

Site/Plant: Pilgrim Station	Weld Identification: RPV-L-2-339C	Pro/Rev/Chg/ICN: ISwT-PDI-AUT1/0/0/1,2	Examination No.: ID-58
Project No.: 02-0285	Weld Description: Ring 3 Vert @ 236°	Device Configuration: D-PNPS-101	
Mod.Conf.: A-07A	Scan Path Drawing: SPLONGSH3TOPDS	Exam Date: 28-Apr-03	Surface Temperature °F:
Data Acquisition Operator (s) / SNT Level: Harper Jacoby / N/A		Examination Time:	
		Start: 1617	End: 1621
		Start: 96	End: 96

Scan Controller Parameters		Increment Axis/Arm	Planned	Actual	Scan Axis/Device	Planned	Actual	Positional Parameters	
Controller:	ID Device	Lower Limit	46159	46160	Lower Limit	46776	50300	Beam Direction:	Up/Dn
Scan:	Y Axis	Upper Limit	47419	47460	Upper Limit	51744	51744	Transducer Size:	1.00
Increment:	X Axis	Increment Interval	90		DCI	4		Code % of Overlap:	10
Mode:	Automatic Scan	Conversion Counts	100		Conversion Counts	100		Number of Scans:	15
Scan Motion:	Bi-directional	Conversion Units In.	1.00		Conversion Units In.	1.00		Device Position:	D (180)
Correction:	Default	EDAS Radius In.	113.60						

Module Parameters:						Calibration Records:	Examination Notes:
Status	Angle	Direction	Scan Offset	Step Offset			
Channel 1	On	55	(+)	+ 1.40(in)	+ 1.21(in)	PNS-03	Check for limitations due to the proximity of the feedwater and core spray spargers.
Channel 2	On	55	(-)	- 1.40(in)	+ 1.21(in)	80031	
Channel 3	On	SLIC-40	(+)	+ 1.97(in)	- 1.69(in)	80032	
Channel 4	On	SLIC-40	(-)	- 1.97(in)	- 1.69(in)	80033	
Channel 5	On	0T	(+)	+ 0.00(in)	- 1.69(in)	80034	
Channel 6	Off	N/A	N/A	N/A	N/A	80035	Examination Remarks:
Channel 7	Off	N/A	N/A	N/A	N/A	N/A	
Channel 8	Off	N/A	N/A	N/A	N/A	N/A	

Increment & Scan Positions Actual					Recordable Indications			Analyst Remarks	
Scan No.(s)	Increment Position		Scan Position		Yes	No	N/A	Attachment: <input type="checkbox"/> Yes <input checked="" type="checkbox"/> No	Further Evaluation Required: <input type="checkbox"/> Yes <input checked="" type="checkbox"/> No
	Start	Stop	Start	Stop					
1 - 15	46159	47451	50300	51700	Channel 1 <input type="checkbox"/>	Channel 2 <input checked="" type="checkbox"/>	Channel 3 <input type="checkbox"/>	Archive Tape/CD No.: 3A Analysis Tape/CD No.: 1A	
					Channel 4 <input type="checkbox"/>	Channel 5 <input checked="" type="checkbox"/>	Channel 6 <input checked="" type="checkbox"/>		
					Channel 7 <input type="checkbox"/>	Channel 8 <input type="checkbox"/>	Channel 8 <input checked="" type="checkbox"/>		

Analyst / SNT Level / Date:
Hector Diaz

Hector Diaz

III

29-Apr-03

Page 79/240



IHI SOUTHWEST TECHNOLOGIES AUTOMATED ULTRASONIC EXAMINATION RECORD

Site/Plant: Pilgrim Station	Weld Identification: RPV-L-2-339C	Pro/Rev/Chg/ICN: ISwT-PDI-AUT1/0/0/1,2	Examination No.: ID-59 #
Project No.: 02-0285	Weld Description: Ring 3 Vert @ 236°	Device Configuration: D-PNPS-101	
Mod.Conf.: A-07-1D	Scan Path Drawing: SPLONGSH2&3DS	Exam Date: 29-Apr-03	Surface Temperature °F
Data Acquisition Operator (s) / SNT Level: R.A. Riddles / II		Examination Time	Start End
		Start End	Start End
		0430 0457	99 99

Scan Controller Parameters		Increment Axis/Device	Planned	Actual	Scan Axis/Arm	Planned	Actual	Positional Parameters	
Controller:	ID Device	Lower Limit	39650	39657	Lower Limit	46039	36050	Beam Direction:	Ccw/Cw
Scan:	X Axis	Upper Limit	43340	42890	Upper Limit	47539	47529	Transducer Size:	1.00
Increment:	Y Axis	Increment Interval	90		DCI	4		Code % of Overlap:	10
Mode:	Automatic Scan	Conversion Counts	100		Conversion Counts	100		Number of Scans:	42
Scan Motion:	Bi-directional	Conversion Units In.	1.00		Conversion Units In.	1.00		Device Position:	A (0)
Correction:	Default	EDAS Radius In.	113.60						

Module Parameters: A-07-1D Cal 33						Calibration Records:	Examination Notes:
Channel	Status	Angle	Direction	Scan Offset	Step Offset		
Channel 1	On	55	(-)	+ 7.00(in)	+ 0.00(in)	PNS-33	Check for limitations due to the proximity of the feedwater and core spray spargers.
Channel 2	On	55	(+)	- 7.00(in)	+ 0.00(in)	80331	
Channel 3	On	SLIC-40	(-)	+ 4.40(in)	+ 1.00(in)	80332	
Channel 4	On	SLIC-40	(+)	- 4.40(in)	- 1.00(in)	80333	
Channel 5	On	0T	(+)	+ 4.40(in)	- 1.00(in)	80334	Examination Remarks: Limited exam due to proximity of the core spray sparger.
Channel 6	On	0T	(+)	- 4.40(in)	+ 1.00(in)	80335	
Channel 7	Off	N/A	N/A	N/A	N/A	80336	
Channel 8	Off	N/A	N/A	N/A	N/A	N/A	

Increment & Scan Positions Actual				Recordable Indications			Analyst Remarks	
Scan No.(s)	Increment Position		Scan Position		Yes	No	N/A	Attachment: <input type="checkbox"/> Yes <input checked="" type="checkbox"/> No
	Start	Stop	Start	Stop				
1 - 37	39650	42867	46050	47630	Channel 1 <input type="checkbox"/>	<input checked="" type="checkbox"/>	<input type="checkbox"/>	Further Evaluation Required: <input type="checkbox"/> Yes <input checked="" type="checkbox"/> No Archive Tape/CD No.: 4A Analysis Tape/CD No.: 1A
					Channel 2 <input type="checkbox"/>	<input checked="" type="checkbox"/>	<input type="checkbox"/>	
					Channel 3 <input type="checkbox"/>	<input checked="" type="checkbox"/>	<input type="checkbox"/>	
					Channel 4 <input type="checkbox"/>	<input checked="" type="checkbox"/>	<input type="checkbox"/>	
					Channel 5 <input type="checkbox"/>	<input checked="" type="checkbox"/>	<input type="checkbox"/>	
					Channel 6 <input type="checkbox"/>	<input checked="" type="checkbox"/>	<input type="checkbox"/>	
					Channel 7 <input type="checkbox"/>	<input type="checkbox"/>	<input checked="" type="checkbox"/>	
					Channel 8 <input type="checkbox"/>	<input type="checkbox"/>	<input checked="" type="checkbox"/>	

Analyst / SNT Level / Date:
Hector Diaz *Hector Diaz* III 29-Apr-03

Page 80/140



IHI SOUTHWEST TECHNOLOGIES AUTOMATED ULTRASONIC EXAMINATION RECORD

Site/Plant: Pilgrim Station	Weld Identification: RPV-L-2-339C	Pro/Rev/Chg/ICN: ISWT-PDI-AUT1/0/0/1,2	Examination No.: ID-60	
Project No.: 02-0285	Weld Description: Ring 3 Vert @ 236°	Device Configuration: D-PNPS-101		
Mod.Conf.: A-07-1C	Scan Path Drawing: SPLONGSH2&3DS	Exam Date: 29-Apr-03	Examination Time	
Data Acquisition Operator (s) / SNT Level: R.A. Riddles / II		Start: 0512	End: 0522	Surface Temperature °F
		Start: 99	End: 99	

Scan Controller Parameters		Increment Axis/Device	Planned	Actual	Scan Axis/Arm	Planned	Actual	Positional Parameters	
Controller:	ID Device	Lower Limit	43213	42943	Lower Limit	46039	46030	Beam Direction:	Cw/Ccw
Scan:	X Axis	Upper Limit	46903	45020	Upper Limit	47539	47515	Transducer Size:	1.00
Increment:	Y Axis	Increment Interval	90		DCI	4		Code % of Overlap:	10
Mode:	Automatic Scan	Conversion Counts	100		Conversion Counts	100		Number of Scans:	42
Scan Motion:	Bi-directional	Conversion Units In.	1.00		Conversion Units In.	1.00		Device Position:	A (180)
Correction:	Default	EDAS Radius In.	113.60						

Module Parameters: A-07-1C Cal 33						Calibration Records:	Examination Notes:
Status	Angle	Direction	Scan Offset	Step Offset			
Channel 1	On	55	(+)	- 7.00(in)	+ 0.00(in)	PNS-33	Check for limitations due to the proximity of the feedwater and core spray spargers.
Channel 2	On	55	(-)	+ 7.00(in)	+ 0.00(in)	80331	
Channel 3	On	SLIC-40	(+)	- 4.40(in)	- 1.00(in)	80332	
Channel 4	On	SLIC-40	(-)	+ 4.40(in)	+ 1.00(in)	80333	
Channel 5	On	0T	(+)	- 4.40(in)	+ 1.00(in)	80334	Examination Remarks: Limited exam due to proximity of the core spray sparger.
Channel 6	On	0T	(+)	+ 4.40(in)	- 1.00(in)	80335	
Channel 7	Off	N/A	N/A	N/A	N/A	80336	
Channel 8	Off	N/A	N/A	N/A	N/A	N/A	

Scan No.(s)	Increment & Scan Positions Actual				Recordable Indications			Analyst Remarks	
	Increment Position		Scan Position		Yes	No	N/A	Attachment:	
1 - 24	Start: 42943	Stop: 45015	Start: 46039	Stop: 47539	Channel 1 <input type="checkbox"/>	Channel 2 <input checked="" type="checkbox"/>	Channel 3 <input type="checkbox"/>	<input type="checkbox"/> Yes <input checked="" type="checkbox"/> No	Channel 6 inactive.
					Channel 4 <input type="checkbox"/>	Channel 5 <input checked="" type="checkbox"/>	Channel 6 <input type="checkbox"/>	Further Evaluation Required: <input type="checkbox"/> Yes <input checked="" type="checkbox"/> No	
					Channel 7 <input type="checkbox"/>	Channel 8 <input checked="" type="checkbox"/>		Archive Tape/CD No.: 4A	
								Analysis Tape/CD No.: 1A	

Analyst / SNT Level / Date:
 Hector Diaz *Hector Diaz* III 29-Apr-03

Page 81/140



IHI SOUTHWEST TECHNOLOGIES AUTOMATED ULTRASONIC EXAMINATION RECORD

Site/Plant : Pilgrim Station	Weld Identification: RPV-L-2-339C	Pro/Rew/Chg/ICN: ISWT-PDI-AUT1/0/0/1,2	Examination No.: ID-61
Project No.: 02-0285	Weld Description: Ring 3 Vert @ 236°	Device Configuration: D-PNPS-101	
Mod.Conf.: A-07-1D	Scan Path Drawing: SPLONGSH2&3DS	Exam Date: 29-Apr-03	Surface Temperature °F
Data Acquisition Operator (s) / SNT Level:		Examination Time	Start End
		2046 2109	82 82

Scan Controller Parameters	Increment Axis/Arm	Planned	Actual	Scan Axis/Device	Planned	Actual	Positional Parameters
Controller: ID Device	Lower Limit	46776	47496	Lower Limit	46039	46063	Beam Direction: Ccw/Cw
Scan: X Axis	Upper Limit	51186	51186	Upper Limit	47539	47523	Transducer Size: 1.00
Increment: Y Axis	Increment Interval	90		DCI	4		Code % of Overlap: 10
Mode: Automatic Scan	Conversion Counts	100		Conversion Counts	100		Number of Scans: 50
Scan Motion: Bi-directional	Conversion Units In.	1.00		Conversion Units In.	1.00		Device Position: A (0)
Correction: Default	EDAS Radius In.	113.60					

Module Parameters:	A-07-1D	Cal 33				Calibration Records:	Examination Notes:
	Status	Angle	Direction	Scan Offset	Step Offset	PNS-33	
Channel 1	On	55	(-)	+ 7.00(in)	+ 0.00(in)	80331	Check for limitations due to the proximity of the feedwater and core spray spargers.
Channel 2	On	55	(+)	- 7.00(in)	+ 0.00(in)	80332	
Channel 3	On	SLIC-40	(-)	+ 4.40(in)	+ 1.00(in)	80333	
Channel 4	On	SLIC-40	(+)	- 4.40(in)	- 1.00(in)	80334	
Channel 5	On	OT	(+)	+ 4.40(in)	- 1.00(in)	80335	
Channel 6	On	OT	(+)	- 4.40(in)	+ 1.00(in)	80336	
Channel 7	Off	N/A	N/A	N/A	N/A	N/A	Examination Remarks: Limited exam due to the proximity of the core spray sparger.
Channel 8	Off	N/A	N/A	N/A	N/A	N/A	

Scan No.(s)	Increment & Scan Positions Actual				Recordable Indications			Attachment:	Analyst Remarks
	Increment Position		Scan Position		Yes	No	N/A		
9 - 50	Start	Stop	Start	Stop	Channel 1	<input type="checkbox"/>	<input checked="" type="checkbox"/>	<input type="checkbox"/>	Channel 6 inactive.
	47476	51154	46039	47539	Channel 2	<input type="checkbox"/>	<input checked="" type="checkbox"/>	<input type="checkbox"/>	
				Channel 3	<input type="checkbox"/>	<input checked="" type="checkbox"/>	<input type="checkbox"/>		
				Channel 4	<input type="checkbox"/>	<input checked="" type="checkbox"/>	<input type="checkbox"/>		
				Channel 5	<input type="checkbox"/>	<input checked="" type="checkbox"/>	<input type="checkbox"/>		
				Channel 6	<input type="checkbox"/>	<input type="checkbox"/>	<input checked="" type="checkbox"/>		
				Channel 7	<input type="checkbox"/>	<input type="checkbox"/>	<input checked="" type="checkbox"/>		
				Channel 8	<input type="checkbox"/>	<input type="checkbox"/>	<input checked="" type="checkbox"/>		

Analyst / SNT Level / Date: **Hector Diaz** *Hector Diaz* III 30-Apr-03

log 8/14/0



IHI SOUTHWEST TECHNOLOGIES AUTOMATED ULTRASONIC EXAMINATION RECORD

Site/Plant: Pilgrim Station	Weld Identification: RPV-L-2-339C	Pro/Rev/Chg/ICN: ISWT-PDI-AUT1/0/0/1,2	Examination No.: ID-62
Project No.: 02-0285	Weld Description: Ring 3 Vert @ 236°	Device Configuration: D-PNPS-101	
Mod.Conf.: A-07-1C	Scan Path Drawing: SPLONGSH2&3DS	Exam Date: 29-Apr-03	Surface Temperature °F
Data Acquisition Operator (s) / SNT Level: R.A. Riddles / II		Examination Time	Start / End
		Start: 0608	End: 0615
		Start: 99	End: 99

Scan Controller Parameters		Increment Axis/Device		Planned		Actual		Scan Axis/Arm		Planned		Actual		Positional Parameters	
Controller:	ID Device	Lower Limit	46776	49783	Lower Limit	46039	46039	Lower Limit	46039	46039	Beam Direction:	Ccw/Cw			
Scan:	X Axis	Upper Limit	51186	51289	Upper Limit	47539	47539	Upper Limit	47539	47539	Transducer Size:	1.00			
Increment:	Y Axis	Increment Interval	90		DCI	4		DCI	4		Code % of Overlap:	10			
Mode:	Manual Scan	Conversion Counts	100		Conversion Counts	100		Conversion Counts	100		Number of Scans:	50			
Scan Motion:	Bi-directional	Conversion Units In.	1.00		Conversion Units In.	1.00		Conversion Units In.	1.00		Device Position:	A (180)			
Correction:	Default	EDAS Radius In.	113.60		EDAS Radius In.	113.60		EDAS Radius In.	113.60						

Module Parameters: A-07-1C Cal 33						Calibration Records:		Examination Notes:	
Channel	Status	Angle	Direction	Scan Offset	Step Offset	PNS-33		Check for limitations due to the proximity of the feedwater and core spray spargers.	
Channel 1	On	55	(+)	- 7.00(in)	+ 0.00(in)	80331			
Channel 2	On	55	(-)	+ 7.00(in)	+ 0.00(in)	80332			
Channel 3	On	SLIC-40	(+)	- 4.40(in)	- 1.00(in)	80333			
Channel 4	On	SLIC-40	(-)	+ 4.40(in)	+ 1.00(in)	80334		Examination Remarks:	
Channel 5	On	OT	(+)	- 4.40(in)	+ 1.00(in)	80335		Limited exam due to proximity of the core spray sparger.	
Channel 6	On	OT	(+)	+ 4.40(in)	- 1.00(in)	80336			
Channel 7	Off	N/A	N/A	N/A	N/A	N/A			
Channel 8	Off	N/A	N/A	N/A	N/A	N/A			

Increment & Scan Positions Actual					Recordable Indications			Analyst Remarks	
Scan No.(s)	Increment Position		Scan Position		Yes	No	N/A	Attachment:	
	Start	Stop	Start	Stop				<input type="checkbox"/> Yes <input checked="" type="checkbox"/> No	Channel 6 inactive.
34 - 52	49718	51287	46039	47539	Channel 1 <input type="checkbox"/>	<input checked="" type="checkbox"/>	<input type="checkbox"/>	<input type="checkbox"/> Yes <input checked="" type="checkbox"/> No	
					Channel 2 <input type="checkbox"/>	<input checked="" type="checkbox"/>	<input type="checkbox"/>	Further Evaluation Required:	
					Channel 3 <input type="checkbox"/>	<input checked="" type="checkbox"/>	<input type="checkbox"/>	<input type="checkbox"/> Yes <input checked="" type="checkbox"/> No	
					Channel 4 <input type="checkbox"/>	<input checked="" type="checkbox"/>	<input type="checkbox"/>	Archive Tape/CD No.:	
					Channel 5 <input type="checkbox"/>	<input checked="" type="checkbox"/>	<input type="checkbox"/>	4A	
					Channel 6 <input type="checkbox"/>	<input type="checkbox"/>	<input checked="" type="checkbox"/>	Analysis Tape/CD No.:	
					Channel 7 <input type="checkbox"/>	<input type="checkbox"/>	<input checked="" type="checkbox"/>	1A	
					Channel 8 <input type="checkbox"/>	<input type="checkbox"/>	<input checked="" type="checkbox"/>		

Analyst / SNT Level / Date: Hector Diaz *Hector Diaz* III 29-Apr-03

Page 83/140

ISWT EXAMINATION SUMMARY RECORD

Project No.: 02-0285

PILGRIM NUCLEAR POWER STATION

Summary Sheet No.: 001300

SITE:	PILGRIM STATION
SYSTEM:	REACTOR PRESSURE VESSEL
LINE/SUBASSEMBLY:	UPPER SHELL-TO-FLANGE
IDENTIFICATION:	RPV-C-4-339

*PNPS ISI Program
Designation
is RPV-SF-
RAB*

NDE Method	Proc/Rev/Chg/ICN	NDE Examination	Calibration Sheet No.	Date Sheet No.	N R I	O T H	Resolution Record	CNF Number	Remarks
AUT	ISWT-PDI-AUT1/0/0/1,2	AUTO	80335,80336	exam 83	X	-	N/A	N/A	Examination no's 83 - 84.
AUT	ISWT-PDI-AUT1/0/0/1,2	AUT45	80041	exam 83	X	-	N/A	N/A	AUTO for thickness measurement only.
AUT	ISWT-PDI-AUT1/0/0/1,2	AUT55	80042	exam 83	X	-	N/A	N/A	Indication detected with AUTSLIC40 was
AUT	ISWT-PDI-AUT1/0/0/1,2	AUTSLIC40	80043,80044	exam 83	-	X	020001	285001	sized with AUTSLIC35 and found to be allowable
AUT	ISWT-PDI-AUT1/0/0/1,2	AUT55T	80331,80332	exam 84	X	-	N/A	N/A	In accordance with the 1989 Edition of ASME
AUT	ISWT-PDI-AUT1/0/0/1,2	AUTSLIC40T	80333,80334	exam 84	X	-	N/A	N/A	Section XI Code.
AUT	ISWT-PDI-AUT1/0/0/1,2	AUTO	80335,80336	exam 84	X	-	N/A	N/A	
AUT	ISWT-PDI-AUT2/0/0/1,2,3	AUTSLIC35	808033	exam 83A-RLA	-	X	020001	285001	

- NOTES:
1. Weld RPV-C-4-339 was examined from the inside surface using AIRIS-21 and EDAS-II examination equipment.
 2. The examination was limited due to proximity of the main steam nozzles, nozzle plugs, guide rods at 0 and 180-degrees, and the configuration of the vessel flange. 81% examination coverage was achieved.
 3. One (1) acceptable flaw indication was recorded and sized.
 4. Detection examination patches included #83A - 83F (6 patches) and 84A - 84AB (53 patches).
 5. Sizing examination patches included #83A-RLA (1 patch).

****UT CALIBRATION BLOCK(s)****
D-70187-2/D70389-1

Prepared by: *Steven J. Todd*
Steven J. Todd Project Engineer

Date: 3 July 2003

Page 1 of 1

Page 84/140

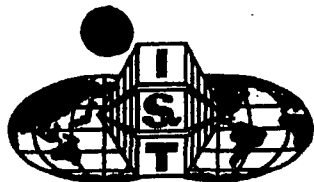

PILGRIM NUCLEAR POWER STATION COVERAGE REPORT RFO 14

Weld No.	Exam Type	Exam No.	X		Y		Sq. Inches Scanned / Exam	Total Sq. Inches Scanned	Sq. Inches Required	Percent	Total Coverage	Remarks							
			Start	Stop	Start	Stop													
RPV-L-1-339A Ring 4 Vert @ 60°	Transverse	63	112.12	124.65	499.44	524.36	312.2	1849	1620	100%	97%	Limitations due to the proximity of N3A nozzle.							
		64	112.12	124.65	524.36	548.78	306.0												
		65	112.12	124.73	548.87	573.20	306.8												
		66	112.12	124.73	573.20	597.62	307.9												
		67	112.12	124.73	597.62	622.04	307.9												
		68	112.12	124.73	622.04	646.46	307.9												
	Parallel	69	110.93	125.93	508.44	578.66	1053.3	1933	2068	93%									
		70-1	110.93	125.93	578.66	592.96	214.5												
			70-2	110.93	120.00	592.96	618.95						235.7						
			70-3	110.93	125.93	618.95	647.60						429.8						
RPV-L-1-339B Ring 4 Vert @ 180°	Transverse	71A	348.99	361.59	499.44	524.36	314.0	1852	1620	100%	100%								
		71B	348.99	361.59	524.36	548.78	307.7												
		71C	348.99	361.59	548.78	573.20	307.7												
		72A	348.99	361.59	573.20	597.62	307.7												
		72B	348.99	361.59	597.62	622.04	307.7												
		72C	348.99	361.59	622.04	646.46	307.7												
	Parallel	73	347.79	362.79	508.29	578.82	1058.0	2098	2068	100%									
		74	347.74	362.79	578.82	647.94	1040.3												
		RPV-L-1-339C Ring 4 Vert @ 300°	Transverse	75	585.86	598.46	499.44						524.36	314.0	1852	1620	100%	98%	Limitations due to the proximity of N3D nozzle.
				76	585.86	598.46	524.36						548.78	307.7					
77	585.86			598.46	548.78	573.20	307.7												
78	585.86			598.46	573.20	597.62	307.7												
79	585.86			598.46	597.62	622.04	307.7												
80	585.86			598.46	622.04	646.46	307.7												
Parallel	81	584.66	599.66	508.31	578.41	1051.5	1985	2068	96%										
	82-1	584.66	599.66	578.41	592.12	205.7													
	82-2	589.42	599.66	592.12	614.96	233.9													
	82-3	584.66	599.66	614.96	647.91	494.2													

Page 85/240

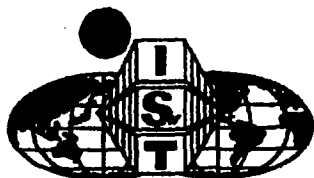

PILGRAIM NUCLEAR POWER STATION COVERAGE REPORT RFO 14

Weld No.	Exam Type	Exam No.	X		Y		Sq. Inches Scanned / Exam	Total Sq. Inches Scanned	Sq. Inches Required	Percent	Total Coverage	Remarks
			Start	Stop	Start	Stop						
RPV-L-2-339A Ring 3 Vert @ 356°	Transverse	39	699.50	712.10	387.50	428.06	511.1	1211	1481	82%	81%	Limitations due to the proximity of the feedwater and core spray spargers.
		40-1	699.50	703.39	428.06	461.15	128.7					
		40-2	703.39	712.10	461.15	468.27	62.0					
		41	699.50	712.10	476.60	504.00	345.2					
	Parallel	42	699.50	712.10	504.00	517.00	163.8					
		43	698.30	713.30	396.50	433.30	552.0					
		44	698.30	713.30	433.30	451.08	266.7					
		45	698.30	713.30	477.38	506.20	432.3					
46	698.30	713.30	506.20	512.81	99.1	1350	1701	79%				
RPV-L-2-339B Ring 3 Vert @ 116°	Transverse	47-1	223.76	231.41	387.50	424.02	279.4	1045	1481	71%	75%	Limitations due to the proximity of the feedwater and core spray spargers and ID taper at circ weld C-3-339A.
		47-2	231.41	234.81	394.34	424.02	100.9					
		47-3	234.81	236.28	396.74	424.02	40.1					
		48	223.68	236.28	424.02	448.15	304.0					
		49	223.68	235.49	475.50	483.50	94.5					
	50	223.68	236.28	503.00	520.96	226.3						
	Parallel	51	222.48	237.48	396.66	408.07	171.2					
		52	222.48	237.48	408.07	450.17	631.5					
53		222.48	237.48	474.68	500.16	382.2						
54	222.48	237.48	500.16	511.86	175.5	1360	1701	80%				
RPV-L-2-339C Ring 3 Vert @ 236°	Transverse	55	461.59	473.92	387.50	408.62	260.4	1244	1481	84%	83%	Limitations due to the proximity of the feedwater and core spray spargers.
		56	461.59	473.18	408.62	448.40	461.1					
		57	461.59	474.19	475.50	504.02	359.4					
		58	461.59	474.19	504.02	517.00	163.5					
	Parallel	59	460.50	476.30	396.50	428.67	508.3					
		60	460.39	475.39	429.43	450.15	310.8					
		61	460.39	475.39	474.76	511.54	551.7					
		62	460.39	475.39	511.54	512.87	19.9					

Page 86/140

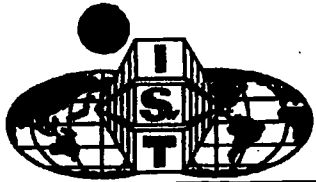

**PILGRIM NUCLEAR POWER STATION
COVERAGE REPORT
RFO 14**

Weld No.	Exam Type	Exam No.	X		Y		Sq. Inches Scanned / Exam	Total Sq. Inches Scanned	Sq. Inches Required	Percent	Total Coverage	Remarks
			Start	Stop	Start	Stop						
RPV-L-1-338A Ring 2 Vert @ 60°	Transverse	19					0.0				28%	Partial exam.
		20					0.0					
		21					0.0					
		22	112.66	125.26	319.93	349.81	376.5					
		23	112.66	125.26	349.81	379.16	369.8					
		24	112.66	125.26	379.16	408.51	369.8	1116	2026	55%		
	Parallel	25					0.0					
		26					0.0	0	2347	0%		
RPV-L-1-338C Ring 2 Vert @ 180°	Transverse	27	350.57	362.02	231.88	261.76	342.1				100%	
		28	350.57	362.73	261.76	291.11	356.9					
		29	350.57	363.10	291.11	320.46	367.8					
		30	350.57	363.17	320.46	349.91	371.1					
		31	350.57	363.17	349.91	379.16	368.6					
		32	350.57	363.17	379.16	408.51	369.8	2176	2026	100%		
	Parallel	33	349.37	364.37	241.33	321.48	1202.3					
		34	349.37	364.37	321.48	400.68	1188.0	2390	2347	100%		

Page 87/240

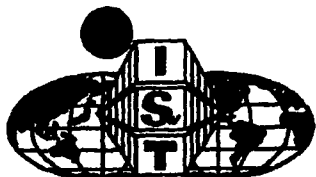

**PILGRAIM NUCLEAR POWER STATION
COVERAGE REPORT
RFO 14**

Weld No.	Exam Type	Exam No.	X		Y		Sq. Inches Scanned / Exam	Total Sq. Inches Scanned	Sq. Inches Required	Percent	Total Coverage	Remarks
			Start	Stop	Start	Stop						
RPV-L-2-338B Ring 1 Vert @ 198°	Transverse	9					0.0				78% Limitations due to the proximity of the baffal plate gusset.	
		10-1	384.71	395.52	136.21	150.41	153.5					
		10-2	395.52	397.28	137.00	150.41	23.6					
		11	384.51	397.12	150.41	176.16	324.7					
		12	384.51	397.12	176.16	201.91	324.7					
		13	384.51	397.12	201.91	227.66	324.7					
		14	384.51	396.94	227.66	253.41	320.1	1471	1620	91%		
	Parallel	15	383.32	398.32	136.31	175.69	590.7					
		16-1	383.32	398.32	175.69	191.55	237.9					
		16-2	383.32	390.50	191.55	204.10	90.1					
		16-3	383.32	390.90	204.10	211.75	58.0					
		16-4	383.32	389.50	211.75	218.04	38.9					
		16-5	383.32	395.60	218.04	238.86	255.7					
	16-6	383.32	398.32	238.86	244.27	81.1	1352	2068	65%			

Page 88/240

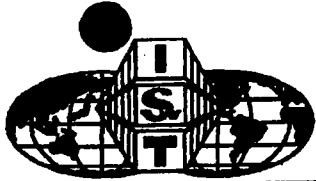

PILGRIM NUCLEAR POWER STATION COVERAGE REPORT RFO 14

Weld No.	Exam Type	Exam No.	X		Y		Sq. Inches Scanned / Exam	Total Sq. Inches Scanned	Sq. Inches Required	Percent	Total Coverage	Remarks
			Start	Stop	Start	Stop						
RPV-C-4-339 Flange	Transverse	84A	1.00	14.40	640.14	652.74	168.8			81%	Limitations due to the N3 nozzles, Plugs, the flange configuration, and the guide rods:	
		84B	14.40	27.80	640.14	652.74	168.8					
		84C	27.80	40.80	640.14	652.74	163.8					
		84D	40.80	54.60	640.14	652.74	173.9					
		84E	54.60	68.00	640.14	652.74	168.8					
		84F	68.00	81.40	640.14	652.74	168.8					
		84G	81.40	94.80	640.14	652.74	168.8					
		84H	94.80	108.20	640.14	652.74	168.8					
		84I	108.20	121.60	640.14	652.74	168.8					
		84J					0.0					
		84K					0.0					
		84L					0.0					
		84M	160.90	175.20	640.14	652.74	180.2					
		84N	174.20	188.60	640.14	652.74	181.4					
		84O	188.60	202.00	640.14	652.74	168.8					
		84P	202.00	215.40	640.14	652.74	168.8					
		84Q					0.0					
		84R	227.80	242.20	640.14	652.74	181.4					
		84S	242.20	255.60	640.14	652.74	168.8					
		84T	255.60	269.00	640.14	652.74	168.8					
84U	269.00	282.40	640.14	652.74	168.8							
84V	282.40	295.80	640.14	652.74	168.8							
84W	295.80	309.20	640.14	652.74	168.8							
84X	309.20	322.60	640.14	652.74	168.8							

Boyle 8/9/14

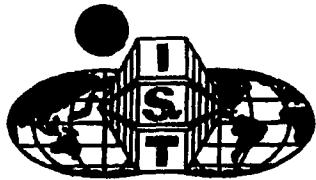

**PILGRIM NUCLEAR POWER STATION
COVERAGE REPORT
RFO 14**

Weld No.	Exam Type	Exam No.	X		Y		Sq. Inches Scanned / Exam	Total Sq. Inches Scanned	Sq. Inches Required	Percent	Total Coverage	Remarks
			Start	Stop	Start	Stop						
RPV-C-4-339 Flange	Transverse	84Y	322.60	336.00	640.14	652.74	168.8	[REDACTED]	[REDACTED]	[REDACTED]	[REDACTED]	Limitations due to the N3 nozzles, Plugs, the flange configuration, and the guide rods.
		84Z	336.00	349.40	640.14	652.74	168.8					
		84AA	348.40	362.80	640.14	652.74	181.4					
		84BB	362.80	376.00	640.14	652.74	166.3					
		84CC	376.00	389.60	640.14	652.74	171.4					
		84DD	389.60	403.00	640.14	652.74	168.8					
		84EE	403.00	416.40	640.14	652.74	168.8					
		84FF	416.40	429.50	640.14	652.74	165.1					
		84GG	429.50	442.92	640.14	652.74	169.1					
		84HH	442.92	456.60	640.14	652.74	172.4					
		84II	456.60	470.00	640.14	652.74	168.8					
		84JJ	470.00	483.20	640.14	652.74	166.3					
		84KK	483.20	496.20	640.14	652.74	163.8					
		84LL					0.0					
		84MM					0.0					
		84NN					0.0					
		84OO	536.00	550.40	640.14	652.74	181.4					
		84PP	550.40	563.80	640.14	652.74	168.8					
		84QQ					0.0					
		84RR					0.0					
		84SS	589.60	603.55	640.14	652.74	175.8					
84TT	603.55	617.00	640.14	652.74	169.5							
84UU	617.00	630.00	640.14	652.74	163.8							
84VV	630.00	644.20	640.14	652.74	178.9							

Boqr 9/14/40

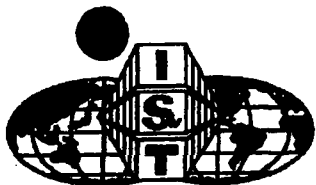

PILGRIM NUCLEAR POWER STATION COVERAGE REPORT RFO 14

Weld No.	Exam Type	Exam No.	X		Y		Sq. Inches Scanned / Exam	Total Sq. Inches Scanned	Sq. Inches Required	Percent	Total Coverage	Remarks
			Start	Stop	Start	Stop						
RPV-C-4-339 Flange	Transverse	84WW	644.20	657.60	640.14	652.74	168.8					Limitations due to the N3 nozzles, Plugs, the flange configuration, and the guide rods.
		84XX	657.60	670.80	640.14	652.74	166.3					
		84YY	670.80	684.40	640.14	652.74	171.4					
		84ZZ	684.40	697.80	640.14	652.74	168.8					
		84AB	697.80	705.29	640.14	652.74	94.4					
	Parallel	83A	0.00	123.23	633.42	652.38	2336.4					
		83B	161.10	194.31	633.42	652.38	629.7					
		83C	232.20	355.77	633.42	652.38	2342.9					
		83D	356.49	478.80	633.42	652.38	2319.0					
		83E	516.43	549.90	633.42	652.38	634.6					
		83F-1	586.80	701.36	633.42	652.38	2172.1					
		83F-2	701.36	705.29	633.42	650.94	68.9					

X is the dimension in the circumferential direction measure in inches from vessel 0°.

Y is the dimension in elevation measured in inches from vessel 0°.

For the Transverse examinations, X is the increment axis, and the Y is the scan axis.

For the Parallel examinations, X is in the scan axis, and Y is the increment axis.

Page 9/140

Page 92/110

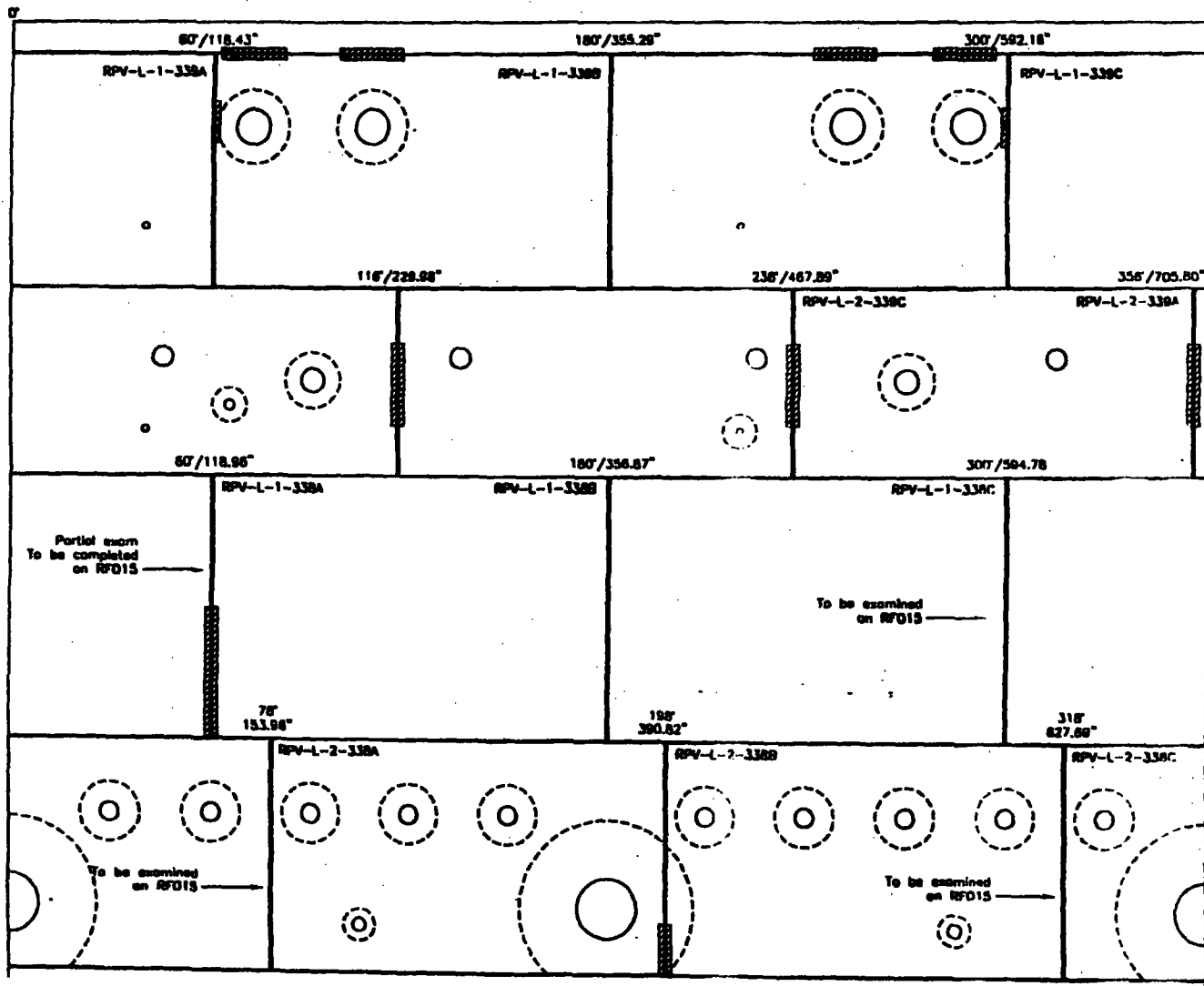

Pilgrim RPV
OD Vessel Rollout (Limitations)
May 2003
Limit RPV.dwg



GE ENERGY, NUCLEAR

EXAMINATION SUMMARY SHEET

Report No.: PIL-R15-05-028

Site: Pilgrim Nuclear Power Station Component ID: RPV-N7A-NV
 Outage: RF-015 NOZZLE TO VESSEL
 System RPV ASME Cat.: B-D ASME Item B3.90 Aug Req N/A

Exams Performed	Data Sheet	Cal Sheet	Procedure	Calibration Block	Examination Personnel	Cert Level	Date
45° Shear	UT-029	N/A	TP04-029 (GE-UT-311)	PIL-5B	J. Kent Montgomery	II	4/22/2005
60° Shear	UT-028	N/A	TP04-029 (GE-UT-311)	PIL-5B	J. Kent Montgomery	II	4/22/2005
60° Long.	UT-003	N/A	TP04-018 (GE-UT-300)	PIL-5B	Brad Dummer	III	4/22/2005
60° Long.	UT-004	N/A	TP04-018 (GE-UT-300)	CAL-IIW2-017	Brad Dummer	III	4/22/2005

Examination Results:

Ultrasonic examination results were acceptable to the requirements of ASME B&PV Code Section XI, 1989 Edition no Addenda, and Section XI, 1995 Edition with the 1996 Addenda as modified by the PDI program description and the Federal Register, Part II, Nuclear Regulatory Commission, 10 CFR Part 50 for Category B-D Reactor Pressure Vessel (RPV) Assembly Welds.

Manual scans from the outside surface were performed in accordance with procedure TP04-018 Rev. 0 (GE-UT-300 V8) and TP04-029 Rev. 0 (GE-UT-311 V10).

No indications were recorded.

Scanning was restricted due to nozzle configuration.

Manual coverage = 56.7%

Examination results were compared to data report 95-E-437,439,441 from 1995 outage with No Change
 These examinations were performed under Work Order: N/A Change

This Summary and the following data sheets have been reviewed and accepted by the following personnel:

Prepared By: [Signature] Level: III Date: 4-24-05 Utility Review: [Signature] Date: 4/27/05
 ANII Review: [Signature] Date: 4/27/05

RWP: 0065
Dose: 1 mr.

Page 1 of 8



GE ENERGY, NUCLEAR

Ultrasonic Calibration and Examination Record
RPV Components

Site/Unit: Pilgrim Nuclear Power Station / 1

Data Report Number: PIL-R15-05-026 Linearity Sheet: L-006

Outage: RF-015

Data Sheet Number: UT-003

Procedure: TP04-018 (GE-UT-300)

Rev.: R0 (V8)

DAR: N/A

Calibration Block: PIL-5B

Search Unit Data

CS Fla: 4.35"

Material Size Thickness

Initial Cal: 0945 Exam Start 1400

Cal Check: N/A Exam End 1440

Cal Check: N/A Ultragel II 01225

Final Cal: 1445 Couplant: Batch

241890 68° F 68° F

Thermometer Initial Cal Temp. Final Cal Temp:

Sigma 22BC-02005 2(1.1"x.62")/Rect.

Manufacturer: Serial Number: Size / Shape:

0.65" 60° 58°

Incident Point: Nominal Angle: Measured Angle:

3.0 MHz SDC-3 Long

Frequency: Model: Mode:

Search Unit Cable

RG-174 12' 0

Cable Type: Length: Connectors:

Instrument Settings

Panametrics / Epoch 4 091540506

Manufacturer/Model: Serial Number:

9.615 us 0.234 in./usec. 0.8 - 3.0 MHz

Delay/Zero: Velocity: Narrowband Filter:

Auto Fullwave 20.0 in. Se./Med

Rep Rate: Rectification: Range: Pulsar:

400 Ohms 0 3.03 MHz Dual

Damping: Reject: Frequency: Mode:

Off Off Off Off

DAC: TVG: CSC: DGS:

DAC Construction

Reflector	Hole Depth	Gain @ 1X	Max Amp	"W" Dim.	Sweep	Screen Div.
N/A	N/A	1X	N/A	N/A	N/A	N/A
N/A	N/A	1X	N/A	N/A	N/A	N/A
N/A	N/A	1X	N/A	N/A	N/A	N/A
ID	<u>4.1"</u>	1X	<u>80%</u>	<u>7.8"</u>	<u>8.2"</u>	<u>4.1</u>
N/A	N/A	1X	N/A	N/A	N/A	N/A

DAC 1X= 62 dB

Sweep 0-10 10.0" Depth

Note N/A dB difference between 3/8 and 5/8 Vee

Exam Data for Weld: RPV-N7A-NV

NOZZLE TO VESSEL

Configuration:

OD 72° F

Exam Surface: Component Temperature

Weld Examination Area:	Exam Access	Scan dB	Recordable Indications	Exam Angle
<u>T/P</u>	<u>OD</u>	<u>68</u>	<u>NRI</u>	<u>60°</u>

Calibration Verification

Field Simulator Block S/N: N/A

Reflector	<u>N/A</u>	<u>N/A</u>	<u>N/A</u>
Amplitude	<u>N/A</u>	<u>N/A</u>	<u>N/A</u>
Gain (dB)	<u>N/A</u>	<u>N/A</u>	<u>N/A</u>
Sweep (SD)	<u>N/A</u>	<u>N/A</u>	<u>N/A</u>

Acceptable Linearity performed: 4/15/2005

Comments: Cal/Exam Date is the date of examination. See coverage sheet for limitations.

Exams performed to maintain a 10% - 20% FSH clad roll.

* Initial cal date: 4/22/05

* Final date: 4/23/05

Numerous spot indications seen but not recordable per procedure.

BD Brad Dummer III 4/22/2005

Initials: Examiner Level Cal/Exam Date:

N/A N/A

Initials: Examiners Level

W. Kelly JH 4-24-05

GE Reviewed By: Level: Date:

Scott L-III 4/27/05

Utility Reviewed By: Date:

Chris Ham 4/27/05

ANII Reviewed By: Date:



GE ENERGY, NUCLEAR

Ultrasonic Calibration and Examination Record
RPV Components

Site/Unit: Pilgrim Nuclear Power Station / 1

Data Report Number: PIL-R15-05-026 Linearity Sheet: L-008

Outage: RF-015

Data Sheet Number: UT-004

Procedure: TP04-018 (GE-UT-300)

Rev.: R0 (V8)

DRR: N/A

Calibration Block: CAL-IIW2-017

Material: CS, Size: N/A, Thickness: 4.0"
Initial Cal: 0945', Exam Star: 1400'
Cal Check: N/A, Exam End: 1440'
Cal Check: N/A, Ultracel II, 01225
Final Cal: 1445', Couplant: Ultracel II, Batch: 01225
Thermometer: 241890, Initial Cal Temp: 68° F, Final Cal Temp: 68° F

Search Unit Data

Sigma: 22BC-0200t, 2(1.1"x.62")/Recl.
Manufacturer: Serial Number: Size / Shape:
0.65", 60°, 59°
Incident Point: Nominal Angle: Measured Angle:
3.0 MHz, SDC-3, Long.
Frequency: Model: Mode:

Search Unit Cable

RG-174, 12', 0
Cable Type: Length: Connectors:

Instrument Settings

Panametrics / Epoch 4, 031540506
Manufacturer/Model: Serial Number:
9.615 MHz, 0.234 in./usec., 0.5 - 3.0 MHz
Delay/Zero: Velocity: Narrowband Filter:
Auto, Fullwave, 4.0 in., Sa./Med
Rep Rate: Rectification: Range: Pulsar:
400 Ohms, 0, 3.03 MHz, Dual
Damping: Reject: Frequency: Mode:
Off, Off, Off, Off
DAC: TVG: CSC: DGS:

DAC Construction

Table with 7 columns: Reflector, Hole Depth, Gain @ 1X, Max Amp, "W" Dim., Sweep, Screen Div.
Rows: 1/4, 0.8", 1X, 80%, 1.0", .58", 2.8; N/A, N/A, 1X, N/A, N/A, N/A, N/A; N/A, N/A, 1X, N/A, N/A, N/A, N/A; N/A, N/A, 1X, N/A, N/A, N/A, N/A; N/A, N/A, 1X, N/A, N/A, N/A, N/A

DAC 1X= 58 dB
Sweep 0-10 2.0" Depth
Note N/A dB difference between 3/8 and 5/8 Vee

Exam Data for Weld: RPV-N7A-NV
NOZZLE TO VESSEL

Configuration:

Exam Surface: OD, Component Temperature: 72° F

Table with 5 columns: Weld Examination Area, Exam Access, Scan dB, Recordable Indications, Exam Angle
Row: I/P, OD, 72, NRI, 60°

Calibration Verification

Field Simulator Block S/N: N/A

Table with 4 columns: Reflector, Amplitude, Gain (dB), Sweep (SD)
Rows: N/A, N/A, N/A, N/A; N/A, N/A, N/A, N/A; N/A, N/A, N/A, N/A; N/A, N/A, N/A, N/A

Acceptable Linearity performed: 4/15/2005

Comments: Cal/Exam Date is the date of examination. See coverage sheet for limitations.

Calibration for near surface examination.

* Initial cal date: 4/22/05

* Final date: 4/23/05

Numerous spot indications seen but not recordable per procedure.

Examiner: Bred Dummer, Level: III, Cal/Exam Date: 4/22/2005

Examiner: N/A, Level: N/A
Examiner: [Signature], Level: III, Date: 4-24-05
GE Reviewed By: [Signature], Level: [Signature], Date: [Signature]

Utility Reviewed By: [Signature], Date: 4/27/05
ANII Reviewed By: [Signature], Date: 4/28/05

Page 95/240



GE ENERGY, NUCLEAR

Ultrasonic Calibration and Examination Record Inner Radius Examinations

Site/Unit: Pilgrim Nuclear Power Station / 1

Data Report Number: PIL-R15-05-026 Linearity Sheet: L-004

Outage: RF-015

Data Sheet Number: UT-028

Procedure: TP04-029 (GE-UT-311)

Rev: R0 (V10) DRR: N/A

Calibration Data for Block: PIL-5B

<u>CS</u> Material	<u>Flat</u> Size	<u>4.35"</u> Thickness	
Initial Cal: <u>1030</u>		Exam Start: <u>14:00</u>	
Cal Check: <u>N/A</u>		Exam End: <u>14:45</u>	
Cal Check: <u>N/A</u>	<u>Uttracel II</u>	<u>01225</u>	
Final Cal: <u>1405</u>	Couplant:	Batch	
<u>241880</u>	<u>68° F</u>	<u>68° F</u>	
Thermometer	Initial Cal Temp.	Final Cal Temp.	

DAC Construction

Side	Depth	Gain @ 1X	Max Amp	"W" Dim.	Sweep	Screen Div.
ID	<u>4.1"</u>	1X	<u>80%</u>	<u>7.8"</u>	<u>9.16"</u>	<u>4.6</u>
N/A	<u>N/A</u>	1X	<u>N/A</u>	<u>N/A</u>	<u>N/A</u>	<u>N/A</u>

DAC @ 1X 41 dB

Sweep 0-10 20 Metal Path

Acceptable Linearity performed: 4/15/2005

Search Unit Data

<u>KBA</u> Manufacturer:	<u>010HXM</u> Serial No.:	<u>0.5"x1.0"/Rect.</u> Size/Shape:
<u>0.75 in.</u>	<u>60°</u>	<u>61°</u>
Incident Point:	Nominal Angle:	Measured Angle:
<u>2.25 MHz</u>	<u>113-892-600</u>	<u>Shear</u>
Frequency:	Model:	Mode:

Search Unit Cable

<u>RG-174</u>	<u>12'</u>	<u>0</u>
Cable Type:	Length:	Connectors:

Instrument Settings

<u>Panametrics / Epoch 4</u>	<u>031574111</u>		
Manufacturer/Model:	Serial No.:		
<u>14.27 us</u>	<u>0.128 in/ussec</u>	<u>0.0 - 3.0 MHz</u>	
Zero:	Velocity:	Narrowband Filter:	
<u>Auto</u>	<u>Fullwave</u>	<u>20.0 in.</u>	<u>Sa / Med</u>
Rep Rate:	Rectification:	Range:	Pulsar/Energy
<u>400 Ohms</u>	<u>0</u>	<u>2.0 MHz</u>	<u>P/E</u>
Damping:	Reject:	Frequency:	Mode:
<u>Off</u>	<u>Off</u>	<u>Off</u>	<u>Off</u>
DAC:	TVG:	CSC:	DGS:

Exam Data for Component: RPV-N7A-NV

NOZZLE TO VESSEL

Configuration:

<u>00</u> Exam Surface:	<u>70° F</u> Component Temp.			
Examination Area	Exam Angle	Rotation Angle	Wedge S/N	Scan Recordable dB Indications
<u>0-5"</u>	<u>60°</u>	<u>15° - 85°</u>	<u>N/A</u>	<u>55 NRI</u>

Calibration Verification

Field Simulator Block S/N: N/A

Reflector	<u>N/A</u>	<u>N/A</u>	<u>N/A</u>
Amplitude	<u>N/A</u>	<u>N/A</u>	<u>N/A</u>
Gain (dB)	<u>N/A</u>	<u>N/A</u>	<u>N/A</u>
Sweep (SD)	<u>N/A</u>	<u>N/A</u>	<u>N/A</u>

Comments: Cal/Exam Date is the date of initial calibration. See coverage sheet for limitations.

Exams performed to maintain a 5% FSH ID roll.
Scanned CW and CCW.
Calibration sweep is 20 metal path, examination range setting is 10.
Calibration for nozzle to vessel weld.
* Initial Cal: 4/22/2005
* Final Cal: 4/23/2005

JKM Kent Montgomery

Initials: Examiner:

Level

II 4/22/2005

Cal/Exam Date:

Scott D. L-114 4/27/05

Utility Reviewed By:

Date:

B/M

GE Reviewed By:

III

Level:

4-24-05

Date:

Chris 4/24/05

ANII Reviewed By:

Date:



GE ENERGY, NUCLEAR

Ultrasonic Calibration and Examination Record Inner Radius Examinations

Site/Unit: Pilgrim Nuclear Power Station / 1
Outage: RF-015
Procedure: TP04-029 (GE-UT-311)

Data Report Number: PIL-R15-05-026 Linearity Sheet: L-004
Data Sheet Number: UT-029

Rev: R0 (V10) DRR: N/A

Calibration Data for Block: PIL-5B

CS	Fla	4.35"
Material:	" Size	Thickness
Initial Cal: <u>1020°</u>		Exam Start <u>14:00</u>
Cal Check: <u>N/A</u>		Exam End <u>14:45</u>
Cal Check: <u>N/A</u>	<u>Ultrace II</u>	<u>01225</u>
Final Cal: <u>1400°</u>	Couplant:	Batch
<u>241690</u>	<u>68° F</u>	<u>68° F</u>
Thermometer	Initial Cal Temp.	Final Cal Temp:

DAC Construction

Side	Depth	Gain ⊕ 1X	Max Amp	"W" Dim.	Sweep	Screen Div.
ID	<u>4.1"</u>	1X	<u>80%</u>	<u>4.1"</u>	<u>6.19"</u>	<u>3.1</u>
N/A	N/A	1X	N/A	N/A	N/A	N/A

DAC @ 1X 35.5 dB

Sweep 0-10 20" Metal Path

Acceptable Linearity performed : 4/15/2005

Search Unit Data

<u>KBA</u>	<u>010HXC</u>	<u>0.5"x1.0"/Rect</u>
Manufacturer:	Serial No.:	Size/Shape:
<u>0.7 in.</u>	<u>45°</u>	<u>44°</u>
Incident Point:	Nominal Angle:	Measured Angle:
<u>2.25 MHz</u>	<u>113-892-600</u>	<u>Shear</u>
Frequency:	Model:	Mode:

Search Unit Cable

<u>RG-174</u>	<u>12'</u>	<u>0</u>
Cable Type:	Length:	Connectors:

Instrument Settings

<u>Panametrics / Epoch 4</u>	<u>031574111</u>		
Manufacturer/Model:	Serial No.:		
<u>12.35 us</u>	<u>0.128 in / ussec</u>	<u>0.8 - 3.0 MHz</u>	
Zero:	Velocity:	Narrowband Filter:	
<u>Auto</u>	<u>Fullwave</u>	<u>20.0 in.</u>	<u>Sq. / Mod</u>
Rep Rate:	Rectification:	Range:	Pulse/Energy
<u>400 Ohms</u>	<u>0</u>	<u>2.0 MHz</u>	<u>P/E</u>
Damping:	Reject:	Frequency:	Mode:
<u>Off:</u>	<u>Off:</u>	<u>Off:</u>	<u>Off:</u>
DAC:	TVG:	CSC:	DGS:

Exam Data for Component: RPV-N7A-NV

NOZZLE TO VESSEL

Configuration:

<u>OD</u>	<u>70° F</u>				
Exam Surface:	Component Temp.				
Examination Area	Exam Angle	Rotation Angle	Wedge S/N	Scan dB	Recordable Indications
<u>0-8"</u>	<u>45°</u>	<u>15° - 85°</u>	<u>N/A</u>	<u>49.5</u>	<u>NRI</u>

Calibration Verification

Field Simulator Block S/N: N/A

Reflector	<u>N/A</u>	<u>N/A</u>	<u>N/A</u>
Amplitude	<u>N/A</u>	<u>N/A</u>	<u>N/A</u>
Gain (dB)	<u>N/A</u>	<u>N/A</u>	<u>N/A</u>
Sweep (SD)	<u>N/A</u>	<u>N/A</u>	<u>N/A</u>

Comments: Cal/Exam Date is the date of initial calibration. See coverage sheet for limitations.

Exams performed to maintain a 5% FSH ID roll.
Scanned CW and CCW.
Calibration sweep is 20 metal path, examination range setting is 10.
Calibration for nozzle to vessel weld.
* Initial Cal: 4/22/2005
* Final Cal: 4/23/2005

JWM J. Kent Montgomery II 4/22/2005
Initials: Examiner: Level Cal/Exam Date:

Scott L III 4/27/05
Utility Reviewed By: Date:

RPM 11 4-24-05
GE Reviewed By: Level: Date:

Chris 4/28/05
ANII Reviewed By: Date:

MANUAL DETECTION NOZZLE INNER RADIUS AND BORE INSPECTION REQUIREMENTS							
PLANT		Pilgrim					
PREPARED BY		S.C. MORTENSON			DATE 01/10/05		
NOZZLE EXAM ZONE	SCAN SURFACE	SCAN ANG.	BEAM ANGLE	ROTATION ANGLE	WEDGE RADIUS	MAX MF	FREQ
RECIRC OUTLET							
N/V Weld (M)	PLATE	0 - 3.0"	45.0°	± 70° - 85°	FLAT	10.7"	1 MHz
N/V Weld/Zone 1 (M)	ODBR	50° - 90°	43.0°	83.0°	6.6"	15.9"	1 MHz
Zone 1 (M)	ODBR	35° - 90°	32.9°	82.2°	6.6"	12.9"	1 MHz
Zone 2a (M)	ODBR	35° - 90°	41.2°	48.9°	6.6"	13.4"	1 MHz
RECIRC INLET							
N/V Weld (M)	PLATE	0 - 6.0"	60.0°	± 35° - 65°	FLAT	15.6"	1 MHz
Zone 1 (M)	PLATE	0 - 6.0"	70.0°	± 30°	FLAT	28.0"	1 MHz
Zone 2a (M)	ODBR	55° - 90°	64.8°	20.3°	6.1"	12.2"	1 MHz
TOP HEAD VENT							
N/V (M)	PLATE	0 - 5.0"	60.0°	32° - 56°	FLAT	6.8"	2.25 MHz
ZONE 1-2A (M)	PLATE	0 - 7.0"	70.0°	±25°	FLAT	9.7"	2.25 MHz
ZONE 2A (M)	PLATE	0 - 8.0"	80.0°	±25°	FLAT	12.9"	2.25 MHz
TOP HEAD SPARE							
N/V (M)	PLATE	0 - 8.0"	45.0°	15° - 85°	FLAT	4.6"	2.25 MHz
N/V (M)	PLATE	0 - 5.0"	60.0°	15° - 85°	FLAT	6.8"	2.25 MHz
ZONE 1 (M)	PLATE	0 - 4.0"	80.0°	±56°	FLAT	6.8"	2.25 MHz
ZONE 1-2A (M)	PLATE	0 - 7.0"	70.0°	±30°	FLAT	9.7"	2.25 MHz
ZONE 2A (M)	PLATE	0 - 9.0"	80.0°	±25°	FLAT	17.9"	2.25 MHz

W-071
W-070
W-069

W-072

NOTES:	*	DESIGN / (FIXTURE) ROTATION FOR 3.0" PKG OFFSET
	#	DESIGN / (FIXTURE) ROTATION FOR 1.45" PKG OFFSET
	**	WEDGE / (FIXTURE) ROTATION ANGLE FOR 2.5" OFFSET
	***	DESIGN / (FIXTURE) ROTATION FOR 1.5" PKG OFFSET
	(M)	MANUAL

Questions on this NIR requirements sheet shall be directed to S.C. Mortenson @ 704 948-0253

Scott Mortenson 4/27/05 1/9/2005

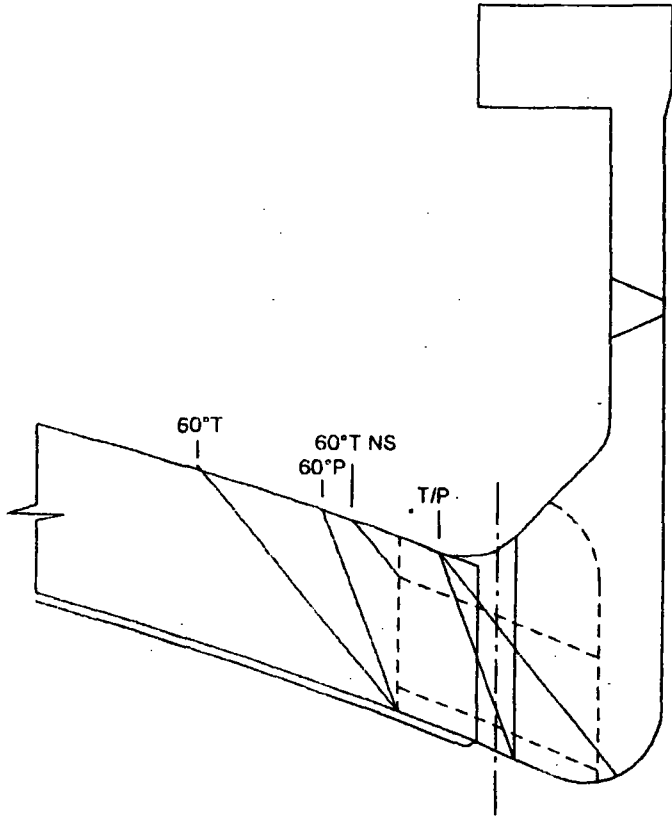

Nozzle Top Side

60° NS Exam Volume = 10.2 Sq. In.
 60° FV Exam Volume = 14.7 Sq. In.
 Inner 15%T Exam Volume = 3.1 Sq. In.

60° NS T-Scan achieved = 1.7 Sq. In.
 60° FV T-Scan achieved = 11.3 Sq. In.
 60° Inner 15% T-Scan achieved = 3.1 Sq. In.

Scan Plan Coverage T and P scans

60° NS P-Scan achieved = 1.3 Sq. In.
 60° FV P-Scan achieved = 5.9 Sq. In.
 60° Inner 15% P-Scan achieved = 3.1 Sq. In.

Pilgrim Weld RPV-N7A-NV Top Head Spray

Nozzle Bottom Side

60° NS Exam Volume = 9.1 Sq. In.
 60° FV Exam Volume = 14.9 Sq. In.
 Inner 15%T Exam Volume = 2.9 Sq. In.

60° NS T-Scan achieved = 2.8 Sq. In.
 60° FV T-Scan achieved = 14.5 Sq. In.
 60° Inner 15% T-Scan achieved = 2.9 Sq. In.

60° NS P-Scan achieved = 2.2 Sq. In.
 60° FV P-Scan achieved = 11.8 Sq. In.
 60° Inner 15% P-Scan achieved = 2.9 Sq. In.

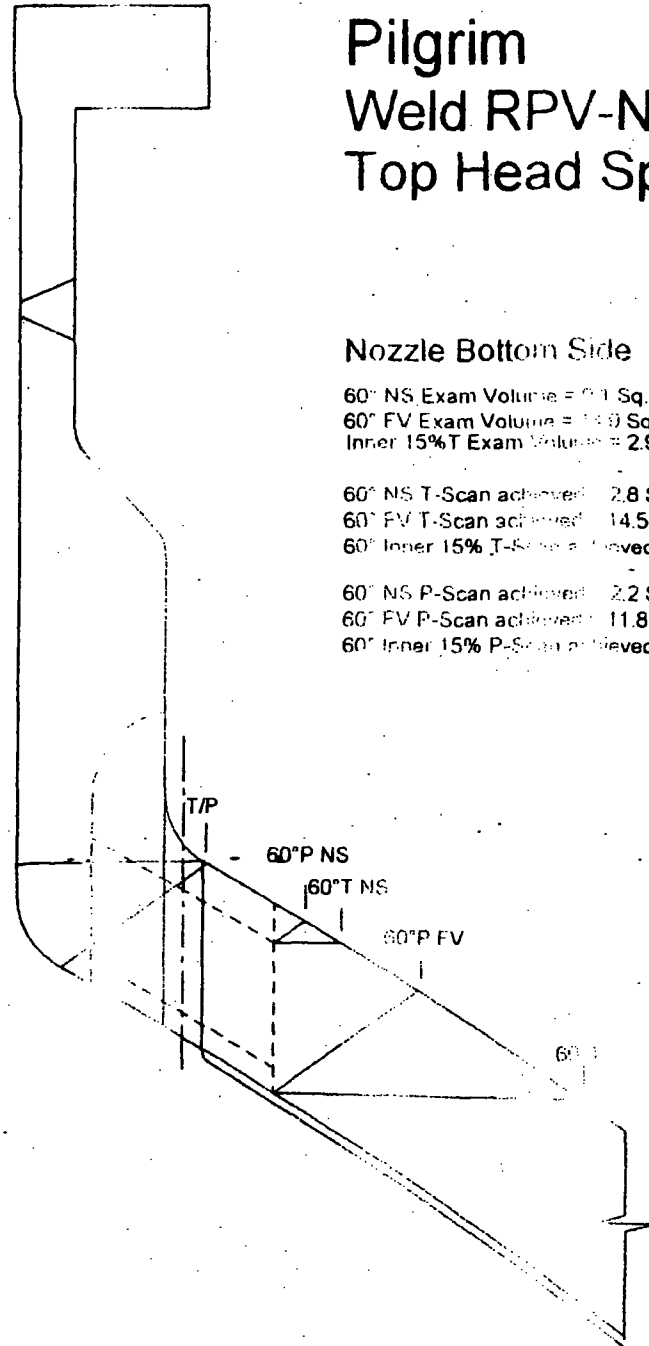



GE ENERGY, NUCLEAR

EXAMINATION SUMMARY SHEET

Report No.: PIL-R15-05-028

Site: Pilgrim Nuclear Power Station Component ID: RPV-N7B-NV
 Outage: RF-015 NOZZLE TO VESSEL
 System RPV ASME Cat.: B-D ASME Item B3.90 Aug Req N/A

Exams Performed	Data Sheet	Cal Sheet	Procedure	Calibration Block	Examination Personnel	Cert Level	Date
45° Shear	UT-033	N/A	TP04-029 (GE-UT-311)	PIL-5E	J. Kent Montgomery	I	4/22/2005
60° Shear	UT-034	N/A	TP04-029 (GE-UT-311)	PIL-5B	J. Kent Montgomery	II	4/22/2005
60° Long.	UT-005	N/A	TP04-018 (GE-UT-300)	PIL-5B	Brad Dummer	III	4/21/2005
60° Long.	UT-006	N/A	TP04-018 (GE-UT-300)	CAL-IIW2-017	Brad Dummer	III	4/22/2005

Examination Results:

Ultrasonic examination results were acceptable to the requirements of ASME B&PV Code Section XI, 1989 Edition no Addenda, and Section XI, 1995 Edition with the 1996 Addenda as modified by the PDI program description and the Federal Register, Part II, Nuclear Regulatory Commission, 10 CFR Part 50 for Category B-D Reactor Pressure Vessel (RPV) Assembly Welds.

Manual scans from the outside surface were performed in accordance with procedures TP04-018 Rev. 0 (GE-UT-300 V8) and TP04-029 Rev. 0 (GE-UT-311 V10).

No indications were recorded.

Scanning was restricted due to nozzle configuration.

Manual coverage = 58.7%.

Examination results were compared to data report 95-E-375,377,379 from 1995 outage with No Change
 These examinations were performed under Work Order: N/A Change

This Summary and the following data sheets have been reviewed and accepted by the following personnel:

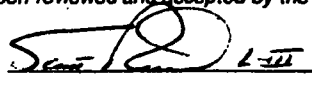
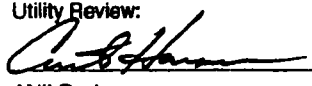
 III 4-24-05  4/28/05
 Prepared By: Level: Date: Utility Review: Date:
 4/28/05
 ANII Review: Date:

RWP: 0065
Dose: 1 mr.

Page 1 of 8



GE ENERGY, NUCLEAR

Ultrasonic Calibration and Examination Record RPV Components

Site/Unit: Pilgrim Nuclear Power Station / 1
Outage: RF-015
Procedure: TP04-018 (GE-UT-300)

Data Report Number: PIL-R15-05-028 Linearity Sheet: L-006
Data Sheet Number: UT-006

Rev.: R0 (V8) DRR: N/A

Calibration Block: CAL-IIW2-017

CS	N/A	4.0"
Material	Size	Thickness
Initial Cal: <u>0945</u>		Exam Start <u>1446</u>
Cal Check: <u>N/A</u>		Exam End <u>1535</u>
Cal Check: <u>N/A</u>	<u>Ultracal II</u>	<u>01225</u>
Final Cal: <u>1445</u>	Couplant:	Batch
<u>241690</u>	<u>68° F</u>	<u>68° F</u>
Thermometer	Initial Cal Temp.	Final Cal Temp:

Search Unit Data

Sigma 22BC-02005 2(1.1"x.62")/Rect.
Manufacturer: Serial Number: Size / Shape:
0.65" 60° 58°
Incident Point: Nominal Angle: Measured Angle:
3.0 MHz SDC-3 Long
Frequency: Model: Mode:

Search Unit Cable

RG-174 12' 0
Cable Type: Length: Connectors:

Instrument Settings

Panometrics / Epoch 4 031540506
Manufacturer/Model: Serial Number:
9.615 us 0.234 in./usec. 0.8 - 3.0 MHz
Delay/Zero: Velocity: Narrowband Filter:
Auto Fullwave 4.0 in. Sa / Med
Rep Rate: Rectification: Range: Puser:
400 Ohms 0 3.03 MHz Dual
Damping: Reject: Frequency: Mode:
Off Off Off Off
DAC: TVG: CSC: DGS:

DAC Construction

Reflector	Hole Depth	Gain @ 1X	Max Amp	"W" Dim.	Sweep	Screen Div.
1/4	0.8"	1X	80%	1.0"	.58"	2.8
N/A	N/A	1X	N/A	N/A	N/A	N/A
N/A	N/A	1X	N/A	N/A	N/A	N/A
N/A	N/A	1X	N/A	N/A	N/A	N/A
N/A	N/A	1X	N/A	N/A	N/A	N/A

DAC 1X= 58 dB
Sweep 0-10 2.0" Depth
Note N/A dB difference between 3/8 and 5/8 Vee

Exam Data for Weld: RPV-N7B-NV
NOZZLE TO VESSEL
Configuration:

00 72° F
Exam Surface: Component Temperature

Weld Examination Area:	Exam Access	Scan dB	Recordable Indications	Exam Angle
<u>Plate</u>	<u>I</u>	<u>72</u>	<u>NRI</u>	<u>60°</u>
<u>Plate CW/GCW</u>	<u>P</u>	<u>72</u>	<u>NRI</u>	<u>60°</u>

Calibration Verification

Field Simulator Block S/N: N/A

Reflector	<u>N/A</u>	<u>N/A</u>	<u>N/A</u>
Amplitude	<u>N/A</u>	<u>N/A</u>	<u>N/A</u>
Gain (dB)	<u>N/A</u>	<u>N/A</u>	<u>N/A</u>
Sweep (SD)	<u>N/A</u>	<u>N/A</u>	<u>N/A</u>

Acceptable Linearity performed: 4/15/2005

Comments: Cal/Exam Date is the date of examination. See coverage sheet for limitations.
Calibration for near surface examination. Exams performed a minimum of 14 dB above reference.
* Initial cal date: 4/22/05
* Final cal date: 4/23/05
Numerous spot indications seen but not recordable per procedure.

BD Brad Dummer III 4/22/2005
Initials: Examiner Level Cal/Exam Date:
N/A N/A
Initials: Examiner Level
N/A II 4-25-05
GE Reviewed By: Level: Date:

Scott L. Witt 4/28/05
Utility Reviewed By: Date:
Chris Hansen 4/28/05
ANII Reviewed By: Date:



GE ENERGY, NUCLEAR

Ultrasonic Calibration and Examination Record RPV Components

Site/Unit: Pilgrim Nuclear Power Station / 1
Outage: RF-015
Procedure: TP04-018 (GE-UT-300)

Data Report Number: PIL-R15-05-028 Linearity Sheet: L-008
Data Sheet Number: UT-005
Rev.: R0 (V8) DRR: N/A

Calibration Block: PIL-5B

CS Flat 4.35"
Material Size Thickness
Initial Cal: 0945° Exam Stan: 1445
Cal Check: N/A Exam End: 1535
Cal Check: N/A Ultracal II 01225
Final Cal: 1445° Couplant: Batch
241890 68° F 68° F
Thermometer Initial Cal Temp. Final Cal Temp.

DAC Construction

Reflector	Hole Depth	Gain @ 1X	Max Amp	"W" Dim.	Sweep	Screen Div.
N/A	N/A	1X	N/A	N/A	N/A	N/A
N/A	N/A	1X	N/A	N/A	N/A	N/A
N/A	N/A	1X	N/A	N/A	N/A	N/A
ID	4.1"	1X	80%	7.8"	9.2"	4.1
N/A	N/A	1X	N/A	N/A	N/A	N/A

DAC 1X= 62 dB
Sweep 0-10 10.0" Depth
Note N/A dB difference between 3/8 and 5/8 Vee

Exam Data for Weld: RPV-N7B-NV
NOZZLE TO VESSEL
Configuration:

OD 72° F
Exam Surface: Component Temperature

Weld Examination Area:	Exam Access	Scan dB	Recordable Indications	Exam Angle
<u>Plate</u>	<u>I</u>	<u>68°</u>	<u>NRI</u>	<u>60°</u>
<u>Plate CW/CCW</u>	<u>P</u>	<u>68°</u>	<u>NRI</u>	<u>60°</u>

Search Unit Data

Sigma 22BC-02004 2(1.1"x.62")/Rect.
Manufacturer: Serial Number: Size / Shape:
0.65" 60° 59°
Incident Point: Nominal Angle: Measured Angle:
3.0 MHz SDC-3 Long
Frequency: Model: Mode:

Search Unit Cable

RG-174 12' 0
Cable Type: Length: Connectors:

Instrument Settings

Panametrics / Epoch 4 031540506
Manufacturer/Model: Serial Number:
9.615 us 0.234 in./usec. 0.8 - 3.0 MHz
Delay/Zero: Velocity: Narrowband Filter:
Auto Fullwave 20.0 in. Sg. / Med
Rep Rate: Rectification: Range: Pulsar:
400 Ohms 0 3.03 MHz Dual
Damping: Reject: Frequency: Mode:
Off Off Off Off
DAC: TVG: CSC: DGS:

Calibration Verification

Field Simulator Block S/N: N/A

Reflector	<u>N/A</u>	<u>N/A</u>	<u>N/A</u>
Amplitude	<u>N/A</u>	<u>N/A</u>	<u>N/A</u>
Gain (dB)	<u>N/A</u>	<u>N/A</u>	<u>N/A</u>
Sweep (SD)	<u>N/A</u>	<u>N/A</u>	<u>N/A</u>

Acceptable Linearity performed : 4/15/2005

Comments: Cal/Exam Date is the date of examination. See coverage sheet for limitations.
Calibration for full volume examination. Exams performed to maintain a 10% - 20% FSH clad roll.
* Initial cal date: 4/22/05
* Final cal date: 4/23/05
Numerous spot indications seen but not recordable per procedure.

BD Brad Dummer III 4/22/2005
Initials: Examiner Level Cal/Exam Date:
N/A N/A
Initials: Examiner Level
[Signature] II 4-24-05
GE Reviewed By: Level: Date:

[Signature] L-008 4/28/05
Utility Reviewed By: Date:
[Signature] 4/28/05
ANII Reviewed By: Date:



GE ENERGY, NUCLEAR

Ultrasonic Calibration and Examination Record Inner Radius Examinations

Site/Unit: Pilgrim Nuclear Power Station / 1

Data Report Number: PIL-R15-05-029 Linearity Sheet: L-004

Outage: RF-015

Data Sheet Number: UT-034

Procedure: TP04-029 (GE-UT-311)

Rev: R0 (V10) DRR: N/A

Calibration Data for Block: PIL-5B

<u>CS</u> Material	<u>Flat</u> Size	<u>4.35"</u> Thickness
Initial Cal: <u>1030</u>	Exam Start	<u>15:35</u>
Cal Check: <u>N/A</u>	Exam End	<u>16:25</u>
Cal Check: <u>N/A</u>	<u>Ultragel II</u> Couplant:	<u>01225</u> Batch
Final Cal: <u>1405</u>	<u>241890</u> Thermometer	<u>68° F</u> Initial Cal Temp.
		<u>68° F</u> Final Cal Temp.

DAC Construction

Side	Depth	Gain @ 1X	Max Amp	"W" Dim.	Sweep	Screen Div.
ID	<u>4.1"</u>	<u>1X</u>	<u>80%</u>	<u>7.8"</u>	<u>9.18"</u>	<u>4.6</u>
<u>N/A</u>	<u>N/A</u>	<u>1X</u>	<u>N/A</u>	<u>N/A</u>	<u>N/A</u>	<u>N/A</u>

DAC @ 1X 41 dB

Sweep 0-10 20" Metal Path

Acceptable Linearity performed: 4/15/2005

Search Unit Data

<u>KBA</u> Manufacturer:	<u>010HXM</u> Serial No.:	<u>0.5"x1.0"/Rect.</u> Size/Shape:
<u>0.75 in.</u> Incident Point:	<u>60°</u> Nominal Angle:	<u>61°</u> Measured Angle:
<u>2.25 MHz</u> Frequency:	<u>113-892-600</u> Model:	<u>Shear</u> Mode:

Search Unit Cable

<u>RG-174</u> Cable Type:	<u>12'</u> Length:	<u>0</u> Connectors:
------------------------------	-----------------------	-------------------------

Instrument Settings

<u>Panametrics / Epoch 4</u> Manufacturer/Model:	<u>031574111</u> Serial No.:		
<u>14.27 us</u> Zero:	<u>0.128 in/uscc</u> Velocity:	<u>0.8 - 3.0 MHz</u> Narrowband Filter:	
<u>Auto</u> Rep Rate:	<u>Fullwave</u> Rectification:	<u>20.0 in.</u> Range:	<u>Sc / Mod</u> Pulsar/Energy
<u>400 Ohms</u> Damping:	<u>0</u> Reject:	<u>2.0 MHz</u> Frequency:	<u>P/E</u> Mode:
<u>Off:</u> DAC:	<u>Off:</u> TVG:	<u>Off:</u> CSC:	<u>Off:</u> DGS:

Exam Data for Component: RPV-N7B-NV

NOZZLE TO VESSEL

Configuration:

<u>QR</u> Exam Surface:	<u>70° F</u> Component Temp.				
Examination Area	Exam Angle	Rotation Angle	Wedge S/N	Scan dB	Recordable Indications
<u>0-5"</u>	<u>60°</u>	<u>15° - 85°</u>	<u>N/A</u>	<u>55</u>	<u>NRI</u>

Calibration Verification

Field Simulator Block S/N: N/A

Reflector	<u>N/A</u>	<u>N/A</u>	<u>N/A</u>
Amplitude	<u>N/A</u>	<u>N/A</u>	<u>N/A</u>
Gain (dB)	<u>N/A</u>	<u>N/A</u>	<u>N/A</u>
Sweep (SD)	<u>N/A</u>	<u>N/A</u>	<u>N/A</u>

Comments: Cal/Exam Date is the date of initial calibration. See coverage sheet for limitations.

Exams performed to maintain a 5% FSH ID roll.
Scanned CW and CCW.
Calibration sweep is 20 metal path, examination range setting is 10.
Calibration for nozzle to vessel weld.
* Initial Cal: 4/22/2005
* Final Cal: 4/23/2005

<u>JKM</u> Initials: Examiner:	<u>II</u> Level:	<u>4/22/2005</u> Cal/Exam Date:	<u>[Signature]</u> Utility Reviewed By:	<u>4/28/05</u> Date:
<u>[Signature]</u> GE Reviewed By:	<u>III</u> Level:	<u>4-24-05</u> Date:	<u>[Signature]</u> ANII Reviewed By:	<u>4/28/05</u> Date:



GE ENERGY, NUCLEAR

Ultrasonic Calibration and Examination Record Inner Radius Examinations

Site/Unit: Pilgrim Nuclear Power Station / 1
Outage: RF-015
Procedure: TP04-029 (GE-UT-311)

Data Report Number: PIL-R15-05-029 Linearity Sheet: L-004
Data Sheet Number: UT-033

Rev: R0 (V10) DRR: N/A

Calibration Data for Block: PIL-5B

<u>CS</u> Material	<u>F1el</u> Size	<u>4.35'</u> Thickness			
Initial Cal: <u>1020°</u>		Exam Start: <u>15:35</u>			
Cal Check: <u>N/A</u>		Exam End: <u>16:25</u>			
Cal Check: <u>N/A</u>	<u>Ultrasel II</u> Couplant:	<u>01225</u> Batch			
Final Cal: <u>1400°</u>	<u>241890</u> Thermometer	<u>68° F</u> Initial Cal Temp.	<u>68° F</u> Final Cal Temp.		

DAC Construction

Side	Depth	Gain @ 1X	Max Amp	"W" Dim.	Sweep	Screen Div.
ID	<u>4.1"</u>	1X	<u>80%</u>	<u>4.1"</u>	<u>6.18"</u>	<u>3.1</u>
<u>N/A</u>	<u>N/A</u>	1X	<u>N/A</u>	<u>N/A</u>	<u>N/A</u>	<u>N/A</u>

DAC @ 1X 35.5 dB

Sweep 0-10 20° Metal Path

Acceptable Linearity performed: 4/15/2005

Search Unit Data

<u>KBA</u> Manufacturer:	<u>010HXC</u> Serial No.:	<u>0.5"x1.0"/Rec1</u> Size/Shape:
<u>0.7 in.</u>	<u>45°</u>	<u>44°</u>
Incident Point:	Nominal Angle:	Measured Angle:
<u>2.25 MHz</u> Frequency:	<u>113-892-600</u> Model:	<u>Shear</u> Mode:

Search Unit Cable

<u>RG-174</u> Cable Type:	<u>12'</u> Length:	<u>0</u> Connectors:
------------------------------	-----------------------	-------------------------

Instrument Settings

<u>Panametrics / Epoch 4</u> Manufacturer/Model:	<u>031574111</u> Serial No.:		
<u>12.35 us</u> Zero:	<u>0.128 in / ussec</u> Velocity:	<u>0.8 - 3.0 MHz</u> Narrowband Filter:	
<u>Auto</u> Rep Rate:	<u>Fullwave</u> Rectification:	<u>20.0 in.</u> Range:	<u>Sa. / Med</u> Pulsar/Energy
<u>400 Ohms</u> Damping:	<u>0</u> Reject:	<u>2.0 MHz</u> Frequency:	<u>P/E</u> Mode:
<u>Off</u> DAC:	<u>Off</u> TVG:	<u>Off</u> CSC:	<u>Off</u> DGS:

Exam Data for Component: RPV-N7B-NV

NOZZLE TO VESSEL

Configuration:

<u>QR</u> Exam Surface:	<u>70° E</u> Component Temp.				
Examination Area	Exam Angle	Rotation Angle	Wedge S/N	Scan dB	Recordable Indications
<u>0-8"</u>	<u>45°</u>	<u>15° - 85°</u>	<u>N/A</u>	<u>49.5</u>	<u>NRI</u>

Calibration Verification

Field Simulator Block S/N: N/A

Reflector	Amplitude	Gain (dB)	Sweep (SD)
<u>N/A</u>	<u>N/A</u>	<u>N/A</u>	<u>N/A</u>
<u>N/A</u>	<u>N/A</u>	<u>N/A</u>	<u>N/A</u>
<u>N/A</u>	<u>N/A</u>	<u>N/A</u>	<u>N/A</u>

Comments: Cal/Exam Date is the date of initial calibration. See coverage sheet for limitations.

Exams performed to maintain a 5% FSH ID roll.
Scanned CW and CCW.
Calibration sweep is 20 metal path, examination range setting is 10.
Calibration for nozzle to vessel weld.
* Initial Cal: 4/22/2005
* Final Cal: 4/23/2005

J. Kent Montgomery
Initials: Examiner:

II
Level

4/22/2005
Cal/Exam Date:

[Signature]
Utility Reviewed By:

4/22/05
Date:

[Signature]
GE Reviewed By:

III
Level

4-24-05
Date:

[Signature]
ANII Reviewed By:

4/24/05
Date:

Page 10 4/240

MANUAL DETECTION NOZZLE INNER RADIUS AND BORE INSPECTION REQUIREMENTS							
PLANT		Pilgrim					
PREPARED BY		S.C. MORTENSON			DATE 01/10/05		
NOZZLE EXAM ZONE	SCAN SURFACE	SCAN AREA	BEAM ANGLE	ROTATION ANGLE	WEDGE RADIUS	MAX MP	FREQ
RECIRC OUTLET							
N/V Weld (M)	PLATE	0 - 8.0"	45.0°	± 70° - 85°	FLAT	10.2"	1 MHz
N/V Weld/Zone 1 (M)	ODBR	50° - 90°	43.0°	83.0°	6.6"	15.9"	1 MHz
Zone 1 (M)	ODBR	35° - 90°	32.9°	82.2°	6.6"	12.9"	1 MHz
Zone 2a (M)	ODBR	35° - 90°	41.2°	48.9°	6.6"	13.4"	1 MHz
RECIRC INLET							
N/V Weld (M)	PLATE	0 - 6.0"	60.0°	± 35° - 65°	FLAT	15.6"	1 MHz
Zone 1 (M)	PLATE	0 - 8.0"	70.0°	± 30°	FLAT	28.0"	1 MHz
Zone 2a (M)	ODBR	55° - 90°	64.8°	20.3°	6.1"	12.2"	1 MHz
TOP HEAD VENT							
N/V (M)	PLATE	0 - 5.0"	60.0°	32° - 56°	FLAT	6.8"	2.25 MHz
ZONE 1-2A (M)	PLATE	0 - 7.0"	70.0°	± 25°	FLAT	9.7"	2.25 MHz
ZONE 2A (M)	PLATE	0 - 8.0"	80.0°	± 25°	FLAT	12.9"	2.25 MHz
TOP HEAD SPARE							
N/V (M)	PLATE	0 - 8.0"	45.0°	15° - 85°	FLAT	4.6"	2.25 MHz
N/V (M)	PLATE	0 - 5.0"	60.0°	15° - 85°	FLAT	6.8"	2.25 MHz
ZONE 1 (M)	PLATE	0 - 8.0"	60.0°	± 35°	FLAT	6.6"	2.25 MHz
ZONE 1-2A (M)	PLATE	0 - 7.0"	70.0°	± 30°	FLAT	10.6"	2.25 MHz
ZONE 2A (M)	PLATE	0 - 9.0"	80.0°	± 25°	FLAT	17.9"	2.25 MHz

W-071
W-070
W-069

W-072

NOTES:
 * DESIGN / (FIXTURE) ROTATION FOR 3.0" PKG OFFSET
 # DESIGN / (FIXTURE) ROTATION FOR 1.45" PKG OFFSET
 ** WEDGE / (FIXTURE) ROTATION ANGLE FOR 2.5" OFFSET
 *** DESIGN / (FIXTURE) ROTATION FOR 1.5" PKG OFFSET
 (M) MANUAL

Questions on this NIR requirements sheet shall be directed to S.C. Mortenson @ 704 948-0253

Pilgrim - RFO15
 Weld RPV-N7B-NV Top Head Spray
 Spring 2005

Weld Length = 360. Exam Volume = 28.		CODE CROSS-SECTIONAL AREA		TOTAL CODE COVERAGE		
		Required Exam Area Sq. In.	Area Scanned Manual	Percent of Area Manual	Weld Length Manual	Percent Manual
60° NS T-Scan	A	10.2	1.7	5.1%	180	1.5%
60° S6 T-Scan	A	14.7	11.3	45.4%	180	10.1%
60° S4 / IRS Scan	A	3.1	3.1	11.1%	180	2.8%
60° NS P-Scan	A	10.2	1.3	4.6%	180	1.2%
60° S6 P-Scan	A	25.6	5.9	21.1%	180	5.3%
60° IRS P-Scan	A	3.1	3.1	11.1%	180	2.8%
60° NS T-Scan	B	9.1	2.8	10.0%	180	2.5%
60° S6 T-Scan	B	14.9	14.5	51.8%	180	12.9%
60° S4 / IRS Scan	B	2.9	2.9	10.4%	180	2.6%
60° NS P-Scan	B	10.2	2.2	7.9%	180	2.0%
60° S6 P-Scan	B	25.6	11.8	42.1%	180	10.5%
60° IRS P-Scan	B	3.1	2.9	10.4%	180	2.6%

% Total Composite Coverage = 56.7%

Comments: A - Examined from the top side of the nozzle 180°. Scanning limited due to nozzle configuration.
 B - Examined from the bottom side of the nozzle 180°. Scanning limited due to nozzle configuration.

Note - Rounding methods may affect calculated values.

Scott L. ... 4/28/05

Page 106/240

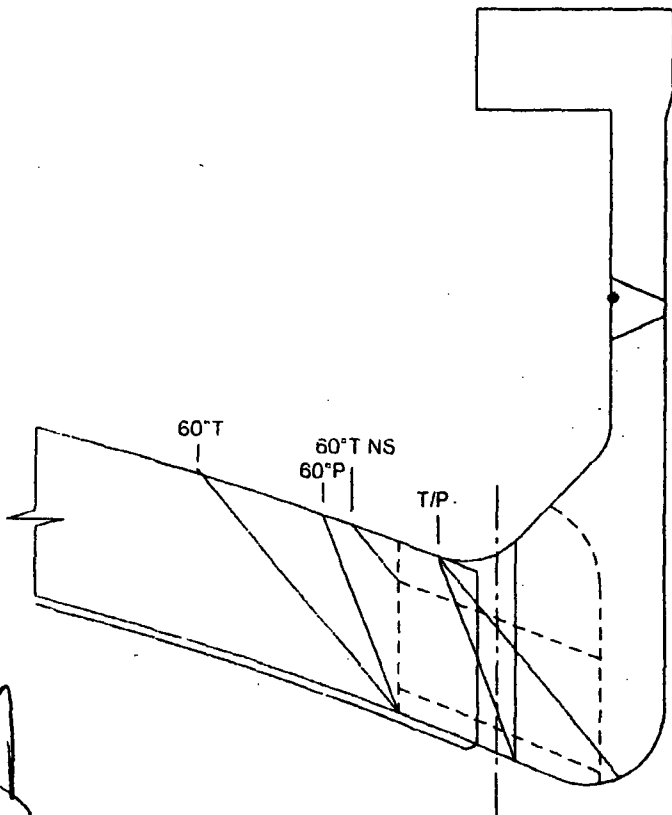

Nozzle Top Side

60° NS Exam Volume = 10.2 Sq. In.
 60° FV Exam Volume = 14.7 Sq. In.
 Inner 15% T Exam Volume = 3.1 Sq. In.

60° NS T-Scan achieved = 1.7 Sq. In.
 60° FV T-Scan achieved = 11.3 Sq. In.
 60° Inner 15% T-Scan achieved = 3.1 Sq. In.

Scan Plan Coverage T and P scans

60° NS P-Scan achieved = 1.3 Sq. In.
 60° FV P-Scan achieved = 5.9 Sq. In.
 60° Inner 15% P-Scan achieved = 3.1 Sq. In.

Pilgrim

Weld RPV-N7B-NV

Top Head Spray

Nozzle Bottom Side

60° NS Exam Volume = 9.1 Sq. In.
 60° FV Exam Volume = 11.0 Sq. In.
 Inner 15% T Exam Volume = 2.9 Sq. In.

60° NS T-Scan achieved = 2.8 Sq. In.
 60° FV T-Scan achieved = 14.5 Sq. In.
 60° Inner 15% T-Scan achieved = 2.9 Sq. In.

60° NS P-Scan achieved = 2.2 Sq. In.
 60° FV P-Scan achieved = 11.8 Sq. In.
 60° Inner 15% P-Scan achieved = 2.9 Sq. In.

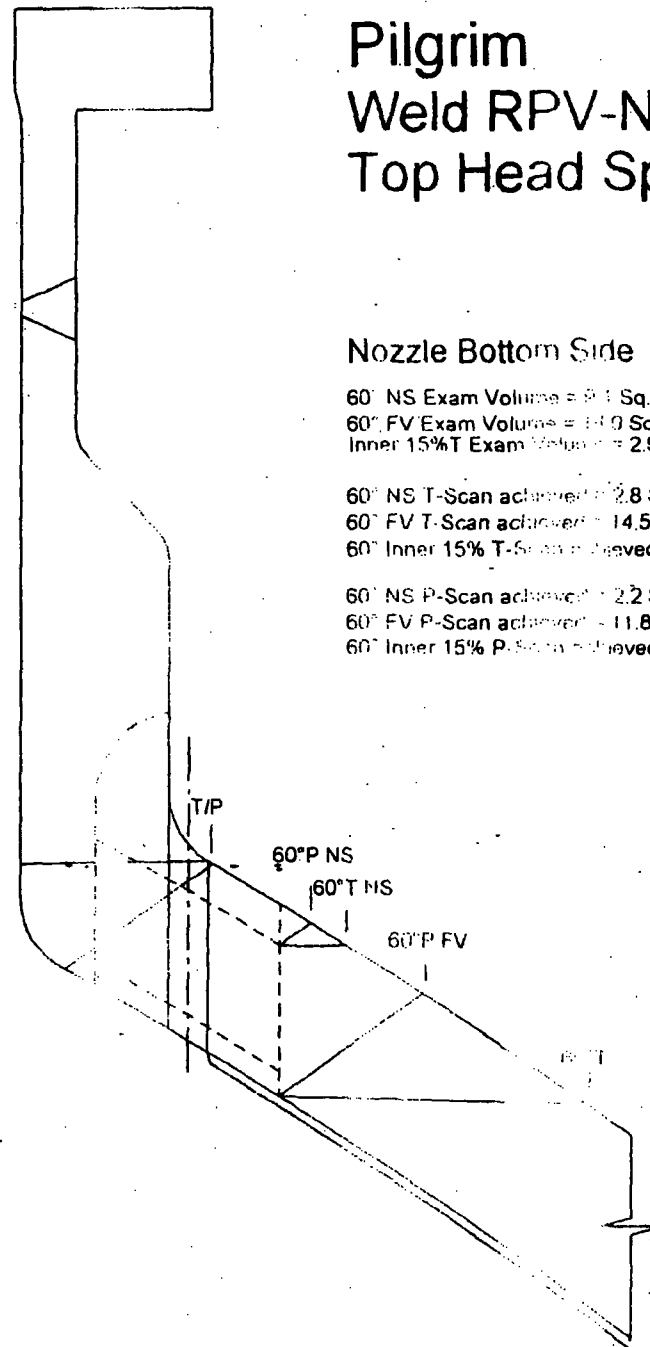

Scan Plan



GE ENERGY, NUCLEAR

EXAMINATION SUMMARY SHEET

Report No.: PIL-R15-05-030

Site: Pilgrim Nuclear Power Station Component ID: RPV-N8-NV
 Outage: RF-015 NOZZLE TO VESSEL
 System RPV ASME Cat.: B-D ASME Item B3.90 Aug Req N/A

Exams Performed	Data Sheet	Cal Sheet	Procedure	Calibration Block	Examination Personnel	Cert Level	Date
60° Shear	UT-025	N/A	TP04-029 (GE-UT-311)	PIL-5B	J. Kent Montgomery	II	4/22/2005
60° Long.	UT-008	N/A	TP04-018 (GE-UT-300)	CAL-IIW2-017	Brad Dummer	III	4/22/2005
60° Long.	UT-007	N/A	TP04-018 (GE-UT-300)	PIL-5B	Brad Dummer	III	4/22/2005

Examination Results:

Ultrasonic examination results were acceptable to the requirements of ASME B&PV Code Section XI, 1989 Edition no Addenda, and Section XI, 1995 Edition with the 1996 Addenda as modified by the PDI program description and the Federal Register, Part II, Nuclear Regulatory Commission, 10 CFR Part 50 for Category B-D Reactor Pressure Vessel (RPV) Assembly Welds.

Manual scans from outside surface were performed in accordance with procedures TP04-018 Rev. 0 (GE-UT-300 V8) and TP04-029 Rev. 0 (GE-UT-311 V10).

Scan was restricted due to nozzle configuration.

No indications were recorded.

Manual coverage = 70.6%

Examination results were compared to data report 95-E-263,265,267 from 1995 outage with No Change

These examinations were performed under Work Order: N/A Change

This Summary and the following data sheets have been reviewed and accepted by the following personnel:

Prepared By: [Signature] Level: III Date: 4-24-05 Utility Review: [Signature] Date: 4/28/05
 ANII Review: [Signature] Date: 4/28/05

RWP: 0065
Dose: 1 mr.

Page 1 of 7

Page 107/240



GE ENERGY, NUCLEAR

Ultrasonic Calibration and Examination Record RPV Components

Site/Unit: Pilgrim Nuclear Power Station / 1
Outage: RF-015

Data Report Number: PIL-R15-05-030 Linearity Sheet: L-006
Data Sheet Number: UT-008

Procedure: TP04-018 (GE-UT-300)

Rev.: R0 (V8)

DRR: N/A

Calibration Block: CAL-IIW2-017

<u>CS</u>	<u>N/A</u>	<u>4.0"</u>
Material	Size	Thickness
Initial Cal: <u>0945*</u>		Exam Star: <u>1540</u>
Cal Check: <u>N/A</u>		Exam End: <u>1605</u>
Cal Check: <u>N/A</u>	<u>Ultrage II</u>	<u>01225</u>
Final Cal: <u>1445*</u>	Couplant:	Batch
<u>241890</u>	<u>68° F</u>	<u>68° F</u>
Thermometer	Initial Cal Temp.	Final Cal Temp:

Search Unit Data

<u>Sigma</u>	<u>22BC-02005</u>	<u>2(1.1"x.62")/Rect.</u>
Manufacturer:	Serial Number:	Size / Shape:
<u>0.65°</u>	<u>60°</u>	<u>52°</u>
Incident Point:	Nominal Angle:	Measured Angle:
<u>3.0 MHz</u>	<u>SDC-3</u>	<u>Long</u>
Frequency:	Model:	Mode:

Search Unit Cable

<u>RG-174</u>	<u>12'</u>	<u>0</u>
Cable Type:	Length:	Connectors:

Instrument Settings

<u>Panametrics / Epoch 4</u>	<u>031540506</u>		
Manufacturer/Model:	Serial Number:		
<u>9.615 in</u>	<u>0.234 in./usec.</u>	<u>0.8 - 3.0 MHz</u>	
Delay/Zero:	Velocity:	Narrowband Filter:	
<u>Auto</u>	<u>Fullwave</u>	<u>4.0 in.</u>	<u>So / Mod</u>
Rep Rate:	Rectification:	Range:	Pulser:
<u>400 Ohms</u>	<u>0</u>	<u>3.03 MHz</u>	<u>Dual</u>
Damping:	Reject:	Frequency:	Mode:
<u>Off</u>	<u>Off</u>	<u>Off</u>	<u>Off</u>
DAC:	TVG:	CSC:	DGS:

DAC Construction

Reflector	Hole Depth	Gain @ 1X	Max Amp	"W" Dim.	Sweep	Screen Div.
1/4	0.6"	1X	80%	1.0"	58"	2.8
N/A	N/A	1X	N/A	N/A	N/A	N/A
N/A	N/A	1X	N/A	N/A	N/A	N/A
N/A	N/A	1X	N/A	N/A	N/A	N/A
N/A	N/A	1X	N/A	N/A	N/A	N/A

DAC 1X= 58 dB
Sweep 0-10 2.0" Depth
Note N/A dB difference between 3/8 and 5/8 Vee

Exam Data for Weld: RPV-N8-NV

NOZZLE TO VESSEL

Configuration:

<u>OD</u>	<u>72° F</u>
Exam Surface:	Component Temperature

Weld Examination Area:	Exam Access	Scan dB	Recordable Indications	Exam Angle
<u>Plate</u>	<u>I</u>	<u>72</u>	<u>NRI</u>	<u>60°</u>
<u>Plate CW/CCW</u>	<u>E</u>	<u>72</u>	<u>NRI</u>	<u>60°</u>

Calibration Verification

Field Simulator Block S/N: N/A

Reflector	Amplitude	Gain (dB)	Sweep (SD)
<u>N/A</u>	<u>N/A</u>	<u>N/A</u>	<u>N/A</u>
<u>N/A</u>	<u>N/A</u>	<u>N/A</u>	<u>N/A</u>
<u>N/A</u>	<u>N/A</u>	<u>N/A</u>	<u>N/A</u>

Acceptable Linearity performed : 4/15/2005

Comments: Cal/Exam Date is the date of examination. See coverage sheet for limitations.
Calibration for near surface examination. Exams performed a minimum of 14 dB above reference.
* Initial cal date: 4/22/05
* Final cal date: 4/23/05
Numerous spot indications seen but not recordable per procedure.

<u>BD</u>	<u>Brad Dummer</u>	<u>III</u>	<u>4/22/2005</u>
Initials:	Examiner	Level	Cal/Exam Date:
<u>N/A</u>	<u>N/A</u>	<u>N/A</u>	
Initials:	Examiner	Level	
<u>[Signature]</u>	<u>II</u>	<u>4-24-05</u>	
GE Reviewed By:	Level:	Date:	

<u>[Signature]</u>	<u>4/24/05</u>
Utility Reviewed By:	Date:
<u>[Signature]</u>	<u>4/24/05</u>
ANII Reviewed By:	Date:



GE ENERGY, NUCLEAR

Ultrasonic Calibration and Examination Record RPV Components

Site/Unit: Pilgrim Nuclear Power Station / 1
Outage: RF-015

Data Report Number: PIL-R15-05-030 Linearity Sheet: L-006
Data Sheet Number: UT-007

Procedure: TP04-018 (GE-UT-300)

Rev.: R0 (V0)

DRR: N/A

Calibration Block: PIL-5B

<u>CS</u>	<u>Flat</u>	<u>4.35"</u>
Material	Size	Thickness
Initial Cal: <u>0945*</u>		Exam Stan <u>1540</u>
Cal Check: <u>N/A</u>		Exam End <u>1605</u>
Cal Check: <u>N/A</u>	<u>Ultracel II</u>	<u>01225</u>
Final Cal: <u>1445*</u>	Couplant:	Batch
<u>241890</u>	<u>68° F</u>	<u>68° F</u>
Thermometer	Initial Cal Temp.	Final Cal Temp:

DAC Construction

Reflector	Hole Depth	Gain @ 1X	Max Amp	"W" Dim.	Sweep	Screen Div.
N/A	N/A	1X	N/A	N/A	N/A	N/A
N/A	N/A	1X	N/A	N/A	N/A	N/A
N/A	N/A	1X	N/A	N/A	N/A	N/A
ID	<u>4.1"</u>	1X	<u>80%</u>	<u>7.8"</u>	<u>9.2"</u>	<u>4.1</u>
N/A	N/A	1X	N/A	N/A	N/A	N/A

DAC 1X= 62 dB

Sweep 0-10 10.0" Depth

Note N/A dB difference between 3/8 and 5/8 Vee

Exam Data for Weld: RPV-N8-NV

NOZZLE TO VESSEL

Configuration:

<u>OD</u>	<u>72° F</u>
Exam Surface:	Component Temperature

Weld Examination Area:	Exam Access	Scan dB	Recordable Indications	Exam Angle
<u>Plate</u>	<u>I</u>	<u>68</u>	<u>NRI</u>	<u>60°</u>
<u>Plate CW/CCW</u>	<u>P</u>	<u>68</u>	<u>NRI</u>	<u>90°</u>

Search Unit Data

<u>Sigma</u>	<u>22BC-02005</u>	<u>2(1.1"x.62")/Rect.</u>
Manufacturer:	Serial Number:	Size / Shape:
<u>0.65"</u>	<u>60°</u>	<u>59°</u>
Incident Point:	Nominal Angle:	Measured Angle:
<u>3.0 MHz</u>	<u>SDC-3</u>	<u>Long</u>
Frequency:	Model:	Mode:

Search Unit Cable

<u>RG-174</u>	<u>12'</u>	<u>0</u>
Cable Type:	Length:	Connectors:

Instrument Settings

<u>Panametrics / Epoch 4</u>	<u>031540506</u>		
Manufacturer/Model:	Serial Number:		
<u>9.615 us</u>	<u>0.234 in./usec.</u>	<u>0.8 - 3.0 MHz</u>	
Delay/Zero:	Velocity:	Narrowband Filter:	
<u>Auto</u>	<u>Fullwave</u>	<u>20.0 in.</u>	<u>So. / Mod</u>
Rep Rate:	Rectification:	Range:	Pulser:
<u>400 Ohms</u>	<u>0</u>	<u>3.03 MHz</u>	<u>Dual</u>
Damping:	Reject:	Frequency:	Mode:
<u>Off</u>	<u>Off</u>	<u>Off</u>	<u>Off</u>
DAC:	TVG:	CSC:	DGS:

Calibration Verification

Field Simulator Block S/N: N/A

Reflector	<u>N/A</u>	<u>N/A</u>	<u>N/A</u>
Amplitude	<u>N/A</u>	<u>N/A</u>	<u>N/A</u>
Gain (dB)	<u>N/A</u>	<u>N/A</u>	<u>N/A</u>
Sweep (SD)	<u>N/A</u>	<u>N/A</u>	<u>N/A</u>

Acceptable Linearity performed : 4/15/2005

Comments: Cal/Exam Date is the date of examination. See coverage sheet for limitations.

Calibration for full volume examination. Exams performed to maintain a 10% - 20% FSH clad roll.

* Initial cal date: 4/22/05

* Final cal date: 4/23/05

Numerous spot indications seen but not recordable per procedure.

BD Brad Dummer III 4/22/2005

Initials: Examiner Level Cal/Exam Date:

N/A N/A

Initials: Examiner Level 4-24-05

GE Reviewed By: [Signature] Level: III Date:

[Signature] 4/28/05

Utility Reviewed By: Date:

[Signature] 4/30/05

ANII Reviewed By: Date:



GE ENERGY, NUCLEAR

Ultrasonic Calibration and Examination Record Inner Radius Examinations

Site/Unit: Pilgrim Nuclear Power Station / 1
Outage: RF-015

Data Report Number: PIL-R15-05-030 Linearity Sheet: L-004
Data Sheet Number: UT-025

Procedure: TP04-029 (GE-UT-311)

Rev: R0 (V10) DRR: N/A

Calibration Data for Block: PIL-5B

<u>CS</u> Material	<u>Flat</u> Size	<u>4.35"</u> Thickness		
Initial Cal: <u>1030°</u>		Exam Start: <u>14:40</u>		
Cal Check: <u>N/A</u>		Exam End: <u>15:30</u>		
Cal Check: <u>N/A</u>	<u>Ultragel II</u>	<u>01225</u>		
Final Cal: <u>1405°</u>	Couplant:	Batch		
<u>241890</u> Thermometer	<u>68° F</u> Initial Cal Temp.	<u>68° F</u> Final Cal Temp:		

DAC Construction

Side	Depth	Gain @ 1X	Max Amp	"W" Dim.	Sweep	Screen Div.
ID	<u>4.1"</u>	<u>1X</u>	<u>80%</u>	<u>7.8"</u>	<u>9.18"</u>	<u>4.6</u>
<u>N/A</u>	<u>N/A</u>	<u>1X</u>	<u>N/A</u>	<u>N/A</u>	<u>N/A</u>	<u>N/A</u>

DAC @ 1X 41 dB

Sweep 0-10 20 Metal Path

Acceptable Linearity performed: 4/15/2005

Search Unit Data

<u>KBA</u> Manufacturer:	<u>010HXM</u> Serial No.:	<u>0.5"x1.0"/Rect.</u> Size/Shape:
<u>0.75 in.</u>	<u>60°</u>	<u>61°</u>
Incident Point:	Nominal Angle:	Measured Angle:
<u>2.25 MHz</u>	<u>113-892-600</u>	<u>Shear</u>
Frequency:	Model:	Mode:

Search Unit Cable

<u>BG-174</u> Cable Type:	<u>12'</u> Length:	<u>0</u> Connectors:
------------------------------	-----------------------	-------------------------

Instrument Settings

<u>Panametrics / Epoch 4</u> Manufacturer/Model:	<u>031574111</u> Serial No.:		
<u>14.27 us</u> Zero:	<u>0.126 in /usec</u> Velocity:	<u>0.8 - 3.0 MHz</u> Narrowband Filter:	
<u>Auto</u> Rep. Rate:	<u>Fulwave</u> Rectification:	<u>20.0 in.</u> Range:	<u>Sa / Mod</u> Pulsar/Energy
<u>400 Ohms</u> Damping:	<u>0</u> Reject:	<u>2.0 MHz</u> Frequency:	<u>P/E</u> Mode:
<u>Off</u> DAC:	<u>Off</u> TVG:	<u>Off</u> CSC:	<u>Off</u> DGS:

Exam Data for Component: RPV-N8-NV

NOZZLE TO VESSEL

Configuration:

<u>OD</u> Exam Surface:	<u>70° F</u> Component Temp.				
Examination Area	Exam Angle	Rotation Angle	Wedge S/N	Scan dB	Recordable Indications
<u>0-5"</u>	<u>60°</u>	<u>32°-56°</u>	<u>N/A</u>	<u>55</u>	<u>NRI</u>

Calibration Verification

Field Simulator Block S/N: N/A

Reflector	Amplitude	Gain (dB)	Sweep (SD)
<u>N/A</u>	<u>N/A</u>	<u>N/A</u>	<u>N/A</u>
<u>N/A</u>	<u>N/A</u>	<u>N/A</u>	<u>N/A</u>
<u>N/A</u>	<u>N/A</u>	<u>N/A</u>	<u>N/A</u>

Comments: Cal/Exam Date is the date of initial calibration. See coverage sheet for limitations.

Exams performed to maintain a 5% FSH ID roll.
Scanned CW and CCW.
Calibration sweep is 20 metal path, examination range setting is 10.
Calibration for nozzle to vessel weld.
* Initial Cal: 4/22/2005
* Final Cal: 4/23/2005

JKM J. Kent Montgomery
Initials: Examiner:

II Level
4/22/2005 Cal/Exam Date:

Sam T. D. L. III Utility Reviewed By:
4/22/05 Date:

B/M/D
GE Reviewed By:

III Level
4-24-05 Date:

Carl Hanan ANII Reviewed By:
4/21/05 Date:

Page 110/240

MANUAL DETECTION NOZZLE INNER RADIUS AND BORE INSPECTION REQUIREMENTS							
PLANT		Pilgrim					
PREPARED BY		S.C. MORTENSON			DATE 01/10/05		
NOZZLE EXAM ZONE	SCAN SURFACE	SCAN AREA	BEAM ANGLE	ROTATION ANGLE	WEDGE RADIUS	MAX MP	FREQ
RECIRC OUTLET							
N/V Weld (M)	PLATE	0 - 3.0	45.0°	± 70° - 80°	FLAT	10.2"	1 MHz
N/V Weld/Zone 1 (M)	ODBR	50° - 90°	43.0°	83.0°	6.6"	15.9"	1 MHz
Zone 1 (M)	ODBR	35° - 90°	32.9°	82.2°	6.6"	12.9"	1 MHz
Zone 2a (M)	ODBR	35° - 90°	41.2°	48.9°	6.6"	13.4"	1 MHz
RECIRC INLET							
N/V Weld (M)	PLATE	0 - 6.0"	60.0°	± 35° - 65°	FLAT	15.6"	1 MHz
Zone 1 (M)	PLATE	0 - 8.0"	70.0°	± 30°	FLAT	28.0"	1 MHz
Zone 2a (M)	ODBR	55° - 90°	64.8°	20.3°	6.1"	12.2"	1 MHz
TOP HEAD VENT							
N/V (M)	PLATE	0 - 5.0"	60.0°	32° - 56°	FLAT	6.8"	2.25 MHz
ZONE 1-2A (M)	PLATE	0 - 7.0"	70.0°	±25°	FLAT	9.7"	2.25 MHz
ZONE 2A (M)	PLATE	0 - 8.0"	80.0°	±25°	FLAT	12.9"	2.25 MHz
TOP HEAD SPARE							
N/V (M)	PLATE	0 - 8.0"	45.0°	15° - 85°	FLAT	4.6"	2.25 MHz
N/V (M)	PLATE	0 - 5.0"	60.0°	15° - 85°	FLAT	6.8"	2.25 MHz
ZONE 1 (M)	PLATE	0 - 4.0"	60.0°	±58°	FLAT	6.8"	2.25 MHz
ZONE 1-2A (M)	PLATE	0 - 7.0"	70.0°	±30°	FLAT	10.6"	2.25 MHz
ZONE 2A (M)	PLATE	0 - 9.0"	80.0°	±25°	FLAT	17.9"	2.25 MHz

W-071
W-070
W-069

W-072

NOTES:
 * DESIGN / (FIXTURE) ROTATION FOR 3.0" PKG OFFSET
 # DESIGN / (FIXTURE) ROTATION FOR 1.45" PKG OFFSET
 ** WEDGE / (FIXTURE) ROTATION ANGLE FOR 2.5" OFFSET
 *** DESIGN / (FIXTURE) ROTATION FOR 1.5" PKG OFFSET
 (M) MANUAL

Questions on this NIR requirements sheet shall be directed to S.C. Mortenson @ 704 948-0253

Page 1 *[Signature]* 4/28/05

1/9/2005

Page 5 of 7

Page 111/240

Pilgrim Weld RPV-N8-NV Top Head Vent

60° NS Exam Volume = 8.2 Sq. In.
60° FV Exam Volume = 13.8 Sq. In.
60° Inner 15% Exam Volume = 3.3 Sq. In.

60° NS T-Scan achieved = 3.5 Sq. In.
60° FV T-Scan achieved = 13.4 Sq. In.
60° Inner 15% T-Scan achieved = 3.3 Sq. In.

60° NS P-Scan achieved = 2.9 Sq. In.
60° FV P-Scan achieved = 9.3 Sq. In.
60° Inner 15% P-Scan achieved = 3.3 Sq. In.

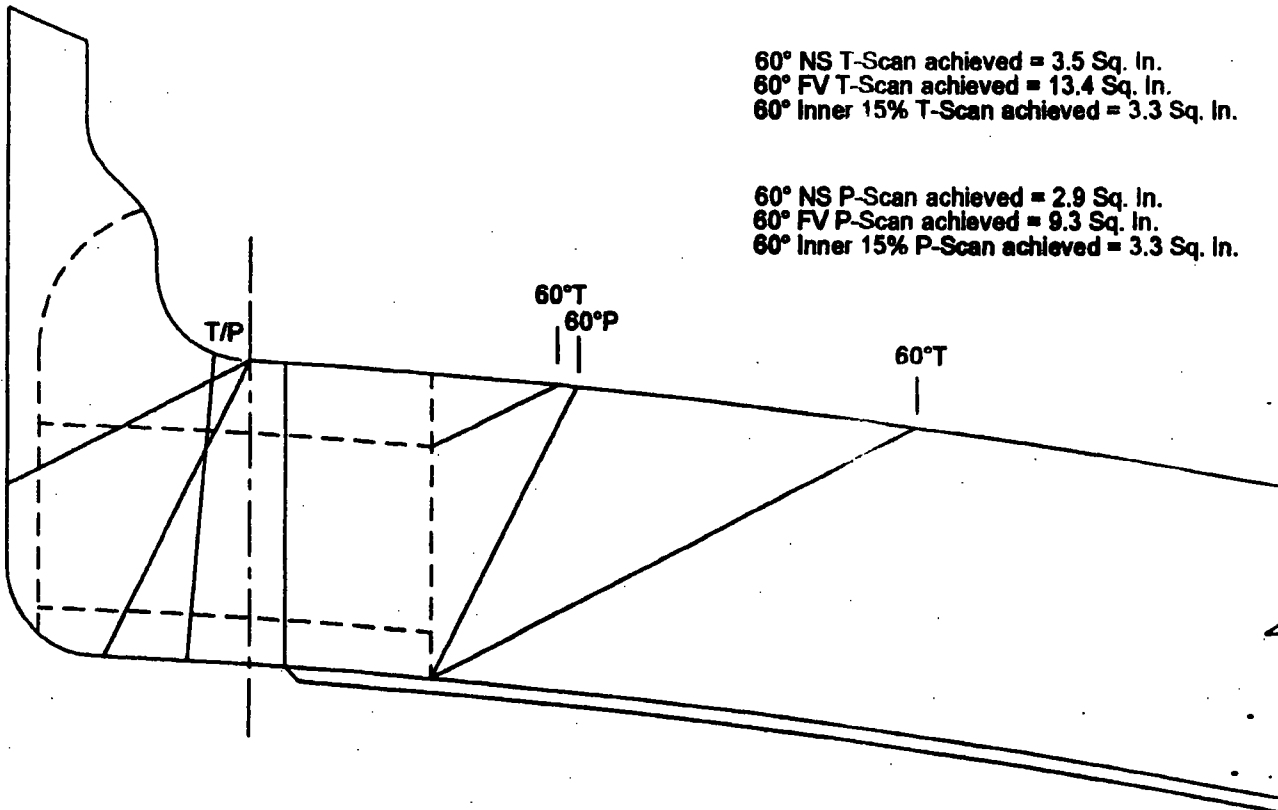

Pilgrim RF015, 2005

Page 7 of 7
Scan 113/240
4/22/05

Page 113/240

Site: Pilgrim Nuclear Power Station **Component ID:** 14-A-10A
Outage: RF-015 **VALVE TO PIPE**
System: CS **ASME Cat.:** B-F **ASME Item:** B5.10 **Aug Req:** IGSCC D

Exams Performed	Data Sheet	Cal Sheet	Procedure	Calibration Block	Examination Personnel	Cert Level	Date
45° Shear	UT-075	N/A	ENR-NDE-9.10	PIL-115	Randy Linden	III	4/28/2005
45° RL	UT-076	N/A	ENR-NDE-9.10	PIL-115	Randy Linden	III	4/28/2005
60° Long.	UT-077	N/A	ENR-NDE-9.10	PIL-115	Randy Linden	III	4/28/2005

Examination Results:

During the manual ultrasonic examination of the above referenced dissimilar metal weld, no indications associated with IGSCC were recorded utilizing a 45° shear wave, 45° and 60° refracted longitudinal wave search units.

The outside surface weld crown did not meet procedure requirements for 360° due to the valve configuration.

22.9% procedural coverage obtained.
 37.1% code coverage obtained.

Previous manual reports and drawings were reviewed prior to this summary.

Examination results were compared to data report 99-E-440 from 1999 outage with No Change
 These examinations were performed under Work Order: 03116643 Change

This Summary and the following data sheets have been reviewed and accepted by the following personnel:

Prepared By: <u><i>RW Halz</i></u>	Level: <u>III</u>	Date: <u>5-2-05</u>	Utility Review: <u><i>[Signature]</i></u>	Date: <u>5-2-05</u>	RWP: 0080 Dose: 133 mr.
ANII Review: <u><i>[Signature]</i></u>					Page <u>1</u> of <u>8</u>

Sego 114/240



GE ENERGY, NUCLEAR

Wall Thickness Profile Sheet

Site: Pikarim Nuclear Power Station Unit: 1

Report No.:

Project: RF-015

APR-002

System: CS

Component ID Number: 14-A-10A

Position	0°	90°	180°	270°
1	N/A	N/A	N/A	N/A
2	N/A	N/A	N/A	N/A
3	0.683	N/A	N/A	N/A
4	0.585	N/A	N/A	N/A
5	0.586	N/A	N/A	N/A

Crown Height: 0.1

Crown Width: 0.8"

Nominal Diameter: 10.0"

Weld Length: 34.0"

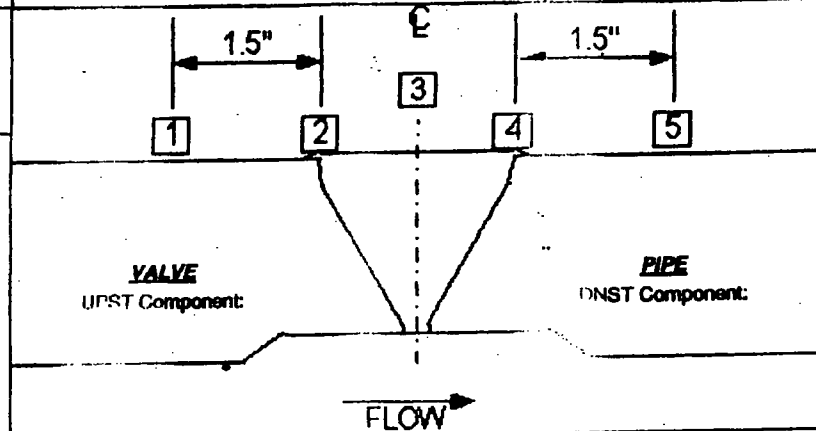

14-A-10A



Valve

Exam Volume

Pipe

Thickness obtained from previous data

Page 115/240

Randy Linden

III 4/28/2005

Initials: Examiner:

Level: Date:

[Signature]

III 5-2-05

Level: Date:

GE Reviewed By:

[Signature]

Utility Review:

III 5-2-05

Date:

[Signature]

ANII Review:

[Signature]

Date:



GE ENERGY, NUCLEAR

Wall Thickness Profile Sheet

Site: Pikarin Nuclear Power Station Unit: 1

Report No.:

Project: RF-018

APR-002

System: CS

Component ID Number: 14-A-10A

Position	0°	90°	180°	270°
1	N/A	N/A	N/A	N/A
2	N/A	N/A	N/A	N/A
3	0.683	N/A	N/A	N/A
4	0.585	N/A	N/A	N/A
5	0.585	N/A	N/A	N/A

Crown Height: 0.1

Crown Width: 0.8"

Nominal Diameter: 10.0"

Weld Length: 24.0"

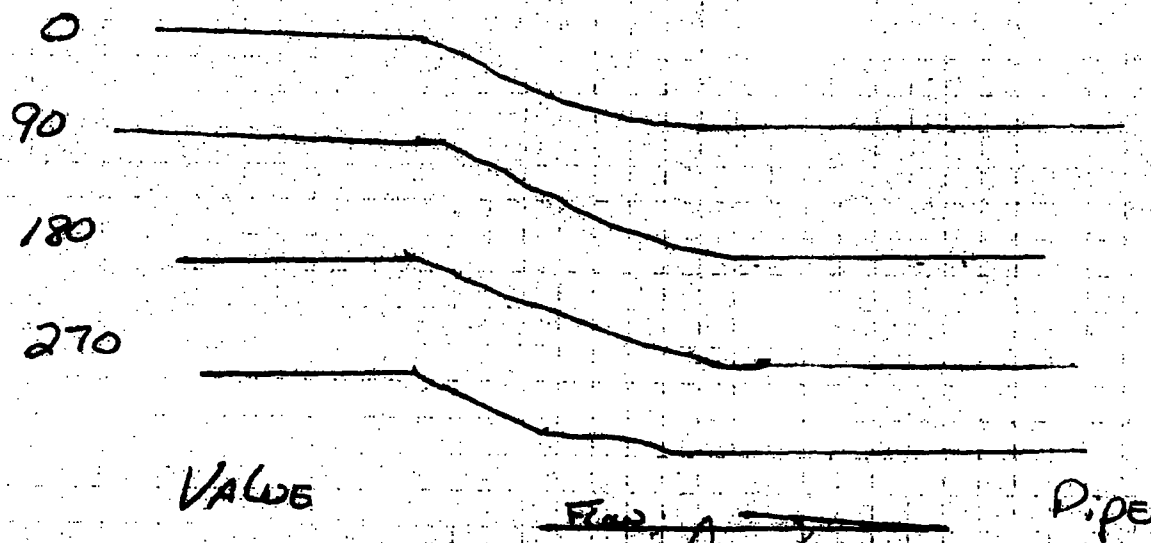
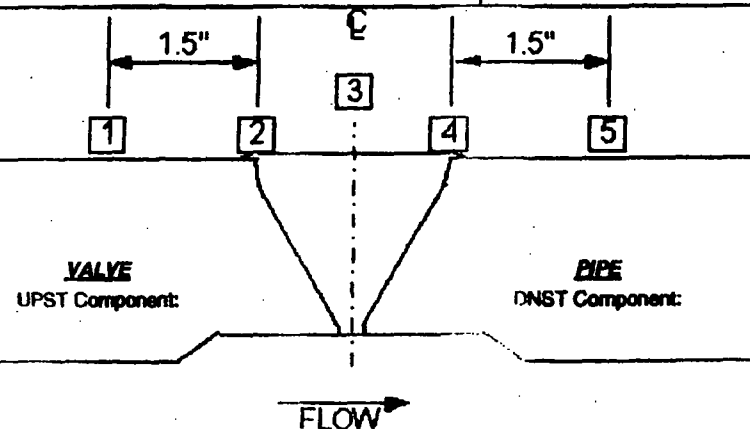

Page 116/240

RL Randy Linden III 1/28/2005
 Initials: Examiner: Level: Date:

[Signature] III 5-2-05
 GE Reviewed By: Level: Date:

[Signature] 4/14/05 5-2-05
 Utility Review: Date:

[Signature] 5/4/05
 ANII Review: Date:

Site/Unit: Pilgrim Nuclear Power Station / 1
Outage: RF-015

Report Number: APR-002
Data Sheet Number: UT-078
Linearity Sheet: L-003

Calibration Data for Block: PIL-115

Procedure: ENN-NDE-9.10

Ver / Rev: 0 DRP: N/A

CS	10"	0.594"	Calibration	Cal Time
Material	Size	Thick	Initial Cal:	<u>0740</u>
Ultracal II	01225		Cal Check:	<u>0817</u>
Couplant:	Couplant batch		Cal Check:	<u>1010</u>
241890	68° F		Final Cal:	<u>1103</u>
Thermometer S/N	Cal Temp.			

Search Unit Data

KBA **010CJP** **0.50"/Round**
Manufacturer: Serial Number Size/Shape:

0.55 in. **45°** **45°**
Incident Point: Nominal Angle: Measured Angle:

2.25 MHz **Comp-G** **Shear** **1**
Frequency: Style: Mode: Elements:

Search Unit Cable

BG-174 **6'** **0**
Cable Type: Length: Connectors:

Instrument Settings

Parametrics / Epoch 4 **031573611**
Manufacturer/Model: Serial Number:

6.285 us **0.128 in./uscc** **0.8 - 3.0 MHz**
Zero: Velocity: Narrowband Filter:

Auto **Fullwave** **1.5 in** **Sa / Max**
Rep Rate: Rectification: Range: Pulsar/Energy:

400 Ohms **Off** **2.0 MHz** **P/E**
Damping: Reject: Frequency: Mode:

DAC Construction

Scan Direction: **Ax**
Cal Reflector: **ID Notch**
Signal Amplitude: **80%**
Signal Sweep: **5.0 Div**
Signal dB: **9.0 dB**
Sweep 0-10 = **1.5 in Metal Path**

Calibration Verification

Field Simulator Block S/N: **CAL-1W2-017**

Reflector	0.60"	N/A
Amplitude	40%	N/A
Gain (dB)	9 dB	N/A
Sweep (SD)	5.6	N/A

Acceptable Linearity performed: **4/15/2005**

Exam Comments / Limitations:

Scanned downstream side only.
Did not scan on weld due to configuration.
Maintained a 5% to 20% ID roll during examination.

Exam Data for Weld: **14-A-10A**

VALVE TO PIPE

Configuration:

QD **88° F** **241890**
Exam Surface: Exam Temp. Exam Thermometer

Axial Circ	UPST DNST	Scan dB	Recordable Indications	Exam Angle
Axial	DNST	23	NBI	45°
Circ	DNST	23	NBI	45°

Exam Start: **0806** Exam End: **0940**

(R)

Randy Linden

III

Initials: Examiner:

Level:

[Signature]
GE Reviewed By:

TVI

5-2-05

Level: Date:

N/A

N/A

Initials: Examiner 2:

Level:

[Signature]
Utility Review:

5-2-05

Date:

Initial Cal/Exam Date: **4/28/2005**

[Signature]
ANII Review:

5/6/05

Date:

Page 4 of 8

**Ultrasonic Calibration and Examination Record
Manual Piping and Components**

Site/Unit: Pilgrim Nuclear Power Station / 1
Outage: RF-015

Report Number: APR-002
Data Sheet Number: UT-078
Linearity Sheet: L-008

Calibration Data for Block: PIL-115

Procedure: ENN-NDE-9.10

Ver / Rev: 0 DRR: N/A

<u>CS</u>	<u>10"</u>	<u>0.594"</u>	Calibration:	Cal Time
Material:	Size	Thick	Initial Cal:	<u>0730</u>
<u>Ultracal II</u>	<u>01225</u>		Cal Check:	<u>0905</u>
Couplant:	Couplant batch		Cal Check:	<u>0955</u>
<u>241890</u>	<u>68° F</u>		Final Cal:	<u>1102</u>
Thermometer S/N	Cal Temp.			

Search Unit Data

RTD 03-177 20x100 mm Rect.
Manufacturer: Serial Number Size/Shape:
0.32 in. 45° 44°
Incident Point: Nominal Angle: Measured Angle:
2.0 MHz TTL2-Aust RL 2
Frequency: Style: Mode: Elements:

Search Unit Cable

RQ-174 5' 0
Cable Type: Length: Connectors:

Instrument Settings

Panametrics / Epoch 4 091573011
Manufacturer/Model: Serial Number:
7.535 MHz 0.236 in./sec. 0.0 - 3.0
Zero: Velocity: Narrowband Filter:
Auto Fullwave 2.0 in Sa / Max
Rep Rate: Rectification: Range: Pulsar/Energy:
400 Ohms Off 2.0 MHz Dual
Damping: Reject: Frequency: Mode:

DAC Construction

Scan Direction: Ax
Cal Reflector: ID Notch
Signal Amplitude: 80%
Signal Sweep: 5.9 Div
Signal dB: 37.9 dB
Sweep 0-10 = 1.5 in Metal Path

Calibration Verification

Field Simulator Block S/N: CAL-11W2-017

Reflector	<u>0.60"</u>	<u>N/A</u>
Amplitude	<u>80%</u>	<u>N/A</u>
Gain (dB)	<u>30.3</u>	<u>N/A</u>
Sweep (SD)	<u>5.6</u>	<u>N/A</u>

Acceptable Linearity performed: 4/15/2005

Exam Data for Weld: 14-A-10A

VALVE TO PIPE

Configuration:

02 68° F 241890
Exam Surface: Exam Temp. Exam Thermometer

Exam Comments / Limitations:

Scanned downstream side only.
Did not scan on weld due to configuration.
Maintained a 20% ID roll during examination.

Axial Circ	UPST DNST	Scan dB	Recordable Indications	Exam Angle
<u>Axial</u>	<u>DNST</u>	<u>43.9</u>	<u>NFI</u>	<u>45°</u>
<u>Circ</u>	<u>DNST</u>	<u>43.9</u>	<u>NFI</u>	<u>45°</u>

Exam Start: 0908 Exam End: 0940

R Randy Linden III
Initials: Examiner: Level:
N/A N/A
Initials: Examiner 2: Level:
Initial Cal/Exam Date: 4/29/2005

[Signature] JIF 5-2-05
GE Reviewed By: Level: Date:
[Signature] UT LUT 19 5-2-05
Utility Review: Date:
[Signature] 5/2/05
ANII Review: Date: 5/2/05



GE ENERGY.NUCLEAR

**Ultrasonic Calibration and Examination Record
Manual Piping and Components**

Site/Unit: Pilgrim Nuclear Power Station / 1
Outage: RE-015

Report Number: APR-002
Data Sheet Number: UT-077
Linearity Sheet: L-008

Calibration Data for Block: PIL-115

Procedure: ENN-NDE-9.10

Ver / Rev: 0 DRR: N/A

CS	10"	0.594"	Calibrator:	Cal Time
Material	Size	Thick	Initial Cal:	<u>0800</u>
<u>Ultrason II</u>	<u>01223</u>		Cal Check:	<u>0830</u>
Couplant:	Couplant batch		Cal Check:	<u>N/A</u>
<u>241890</u>	<u>68°F</u>		Final Cal:	<u>1100</u>
Thermometer S/N	Cal Temp.			

Search Unit Data

RTP 03-179 2(7x10) mm/Rect.
 Manufacturer: Serial Number Size/Shape:
0.32 in. 60° 60°
 Incident Point: Nominal Angle: Measured Angle:
2.0 MHz TRL2-Aust Long 2
 Frequency: Style: Mode: Elements:

Search Unit Cable

RG-174 6' 0
 Cable Type: Length: Connectors:

Instrument Settings

Panametrics / Epoch 4 031573611
 Manufacturer/Model: Serial Number:
6.155 MHz 0.222 in./Amec. 0.0 - 3.0
 Zero: Velocity: Narrowband Filter:
Aide Fulthance 2.0 in Sq. / Max
 Rep Rate: Rectification: Range: Pulsar/Energy:
400 Ohms Off 2.0 MHz Dual
 Damping: Reject: Frequency: Mode:

DAC Construction

Scan Direction Ax
 Cal Reflector ID Notch
 Signal Amplitude 80%
 Signal Sweep: 5.9 Dly
 Signal dB: 47.2 dB
 Sweep 0-10 = 2.0 in Metal Path

Calibration Verification

Field Simulator Block S/N: CAL-9W2-017

Reflector	<u>0.60"</u>	<u>N/A</u>
Amplitude	<u>80%</u>	<u>N/A</u>
Gain (dB)	<u>42.4</u>	<u>N/A</u>
Sweep (SD)	<u>6.0</u>	<u>N/A</u>

Acceptable Linearity performed: 4/15/2005

Exam Comments / Limitations:

Scanned downstream side only .
Did not scan on weld due to configuration.
Maintained a 20 -30% ID roll during examination.

Exam Data for Weld: 14-A-10A

VALVE TO PIPE

Configuration:

00 85°F 241890
 Exam Surface: Exam Temp. Exam Thermometer

Axial Circ	UPST DNST	Scan dB	Recordable Indications	Exam Angle
<u>Axial</u>	<u>DNST</u>	<u>47.2</u>	<u>NBI</u>	<u>60°</u>
<u>Circ</u>	<u>DNST</u>	<u>47.2</u>	<u>NBI</u>	<u>60°</u>

Exam Start: 0906 Exam End: 0940

(Signature)

Randy Linden

Initials: Examiner:

III
Level:

N/A

Initials: Examiner 2:

N/A
Level:

Initial Cal/Exam Date: 4/28/2005

(Signature)

GE Reviewed By:

III 5-2-05
Level: Date:

(Signature) UT LV. III 5-2-05
Utility Review: Date:

(Signature) 5/2/05
ANII Review: Date:

Page 6 of 8

Page 119/240



GE ENERGY, NUCLEAR

EXAMINATION SUMMARY SHEET

Report No.: APR-005

Site: Pilgrim Nuclear Power Station Component ID: 14-B-10A
 Outage: RF-015 VALVE TO PIPE
 System CS ASME Cat.: B-F ASME Item B5.10 Aug Req IGSCC D

Exams Performed	Data Sheet	Cal Sheet	Procedure	Calibration Block	Examination Personnel	Cert Level	Date
45° Shear	UT-072	N/A	ENN-NDE-9.10	PIL-115	Randy Linden	III	4/28/2005
45° RL	UT-073	N/A	ENN-NDE-9.10	PIL-115	Randy Linden	III	4/28/2005
60° Long.	UT-074	N/A	ENN-NDE-9.10	PIL-115	Randy Linden	III	4/28/2005

Examination Results:

During the manual ultrasonic examination of the above referenced dissimilar metal weld, no indications associated with IGSCC were recorded utilizing a 45° shear wave, 45° and 60° refracted longitudinal wave search units.

The outside surface weld crown did not meet procedure requirements for 360° due to the valve configuration and shrinkage at the weld toe.

10.1% procedural coverage obtained.
22.1% code coverage obtained.

Previous manual reports and drawings were reviewed prior to this summary.

Examination results were compared to data report 99-E-441 from 1999 outage with No Change
 These examinations were performed under Work Order: 03118643 Change

This Summary and the following data sheets have been reviewed and accepted by the following personnel:

Prepared By: [Signature] Level: III Date: 5-2-05
 Utility Review: [Signature] Date: 5-2-05
 ANII Review: [Signature] Date: 5/3/05

RWP: 0080
Dose: 133 mr.

Page 1 of 6

Page 120/240



GE ENERGY, NUCLEAR

Wall Thickness Profile Sheet

Site: Plaquemine Nuclear Power Station Unit: 1
Project: RF-218

Report No.: APR-008

System: CS

Component ID Number: 14-B-10A

Position	0°	90°	180°	270°
1	N/A	N/A	N/A	N/A
2	N/A	N/A	N/A	N/A
3	0.728	N/A	N/A	N/A
4	0.545	N/A	N/A	N/A
5	0.557	N/A	N/A	N/A

Crown Height: 0.1
 Crown Width: 1.0"
 Nominal Diameter: 10.0"
 Weld Length: 34.0"

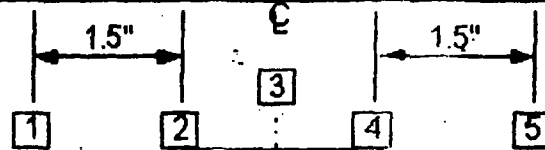

VALVE
INST Component

PIPE
INST Component

FLOW →

14-B-10A

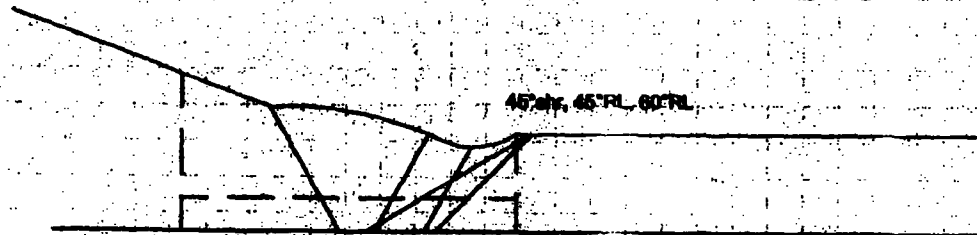

Valve

Exam Volume

Pipe

Thickness obtained from previous data

Max For Randy Linden
Initials: Examiner:

Level: III Date: 4/28/2005

GE Reviewed By: [Signature] Level: III Date: 5-3-05

Utility Review: [Signature] Date: 5-2-05

ANII Review: [Signature] Date: 5/3/05

Page 121/240



GE ENERGY, NUCLEAR

Wall Thickness Profile Sheet

Site: *Edwards Nuclear Power Station* Unit: *1*

Report No.:

Project: *RF-018*

APR-005

System: *GS*

Component ID Number: *14-B-10A*

Position	0°	90°	180°	270°
1	N/A	N/A	N/A	N/A
2	N/A	N/A	N/A	N/A
3	0.728	N/A	N/A	N/A
4	0.545	N/A	N/A	N/A
5	0.557	N/A	N/A </td <td>N/A</td>	N/A

Crown Height: *0.1*

Crown Width: *1.0"*

Nominal Diameter: *10.0"*

Weld Length: *24.0"*

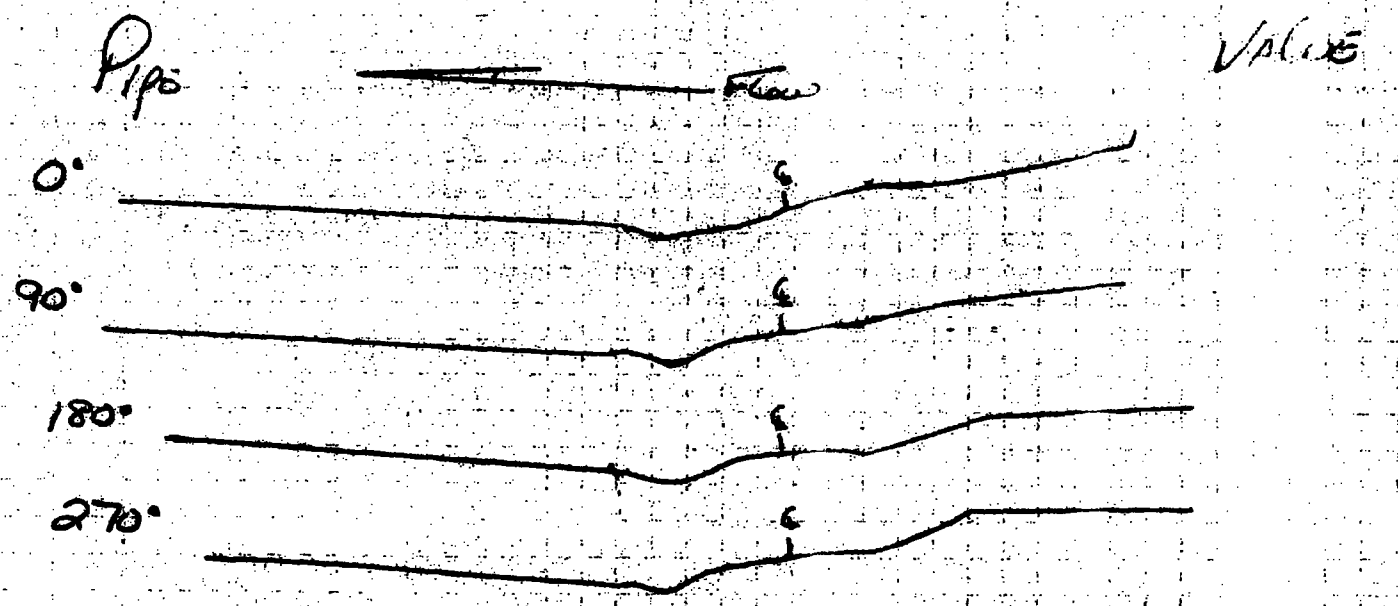
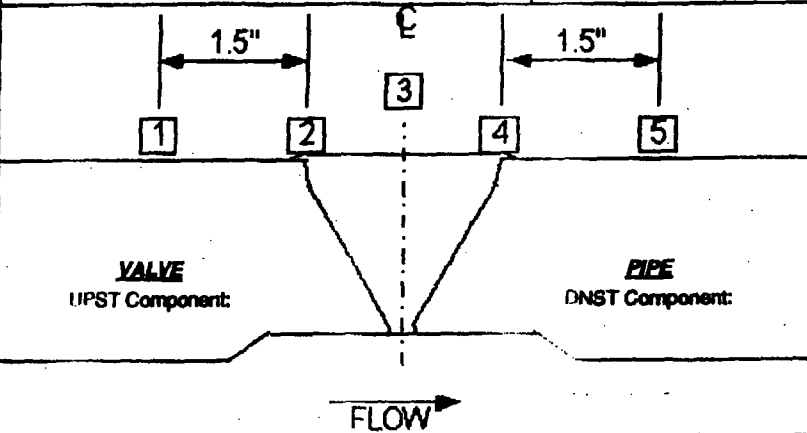

Page 122/140

BL **Bandy Linden** III *4/28/2005*
 Initials: Examiner: Level: Date:

McK... III *5-2-05*
 GE Reviewed By: Level: Date:

[Signature] *4/7/05*
 Utility Review: Date:

[Signature] *5/2/05*
 ANII Review: Date:

Site/Unit: Pilgrim Nuclear Power Station / 1
Outage: RE-015

Report Number: APR-005
Data Sheet Number: UT-072
Linearity Sheet: L-002

Calibration Data for Block: PIL-115

Procedure: ENN-NDE-9.10

Ver / Rev: 0 DRR: N/A

<u>CS</u>	<u>10"</u>	<u>0.584"</u>	Calibration:	Cal Time:
Material	Size	Thick	Initial Cal:	<u>0740</u>
<u>Ultracal II</u>	<u>01225</u>		Cal Check:	<u>0917</u>
Couplant:	Couplant batch		Cal Check:	<u>1010</u>
<u>241890</u>	<u>68° F</u>		Final Cal:	<u>1109</u>
Thermometer S/N	Cal Temp.			

Search Unit Data

KBA 010CJP 0.50" Round
Manufacturer: Serial Number Size/Shape:
0.55 in. 45° 45°
Incident Point: Nominal Angle: Measured Angle:
2.25 MHz Comp-G Shear 1
Frequency: Style: Mode: Elements:

Search Unit Cable

RG-174 8' 0
Cable Type: Length: Connectors:

Instrument Settings

Panometrics / Epoch 4 091573811
Manufacturer/Model: Serial Number:
6.295 us 0.128 in./ussec. 0.8 - 3.0 MHz
Zero: Velocity: Narrowband Filter:
Auto Fulthru 1.5 in Sa / Max
Rep Rate: Rectification: Range: Pulsar/Energy:
400 Ohms Off 2.0 MHz P/E
Damping: Reject: Frequency: Mode:

DAC Construction

Scan Direction Ax
Cal Reflector ID Notch
Signal Amplitude 80%
Signal Sweep: 5.9 Div
Signal dB: 9.0 dB
Sweep 0-10 = 1.3 in Metal Path

Calibration Verification

Field Simulator Block S/N: CAL-HW2-017

Reflector	<u>0.60"</u>	<u>N/A</u>
Amplitude	<u>80%</u>	<u>N/A</u>
Gain (dB)	<u>9 dB</u>	<u>N/A</u>
Sweep (SD)	<u>5.8</u>	<u>N/A</u>

Acceptable Linearity performed : 4/15/2005

Exam Data for Weld: 14-B-10A

VALVE TO PIPE

Configuration:

00 85° F 241890
Exam Surface: Exam Temp. Exam Thermometer

Exam Comments / Limitations:

Scanned downstream side only.
Did not scan on weld due to configuration.
Lift-off signals seen due to weld shrinkage.
Maintained a 5% to 20% ID roll during examination.

Axial Circ	UPST DNST	Scan dB	Recordable Indications	Exam Angle
<u>Axial</u>	<u>DNST</u>	<u>23</u>	<u>NRI</u>	<u>45°</u>
<u>Circ</u>	<u>DNST</u>	<u>23</u>	<u>NRI</u>	<u>45°</u>

Exam Start: 0945 Exam End: 1025

RL Randy Linden III
Initials: Examiner: Level:
N/A N/A
Initials: Examiner 2: Level:
Initial Cal/Exam Date: 4/28/2005

W. Kaly III 5-2-05
GE Reviewed By: Level: Date:
UT Lvl. 1g 5-02-05
Utility Reviewer: Date:
Chris Hanson 5/2/05
ANII Review: Date: 5/2/05 Page 4 of 6



GE ENERGY NUCLEAR

Ultrasonic Calibration and Examination Record
Manual Piping and Components

Site/Unit: Pilgrim Nuclear Power Station / 1
Outage: RF-01B

Report Number: APR-005
Data Sheet Number: UT-073
Linearity Sheet: L-003

Calibration Data for Block: PIL-115

Procedure: ENN-NDE-9.10

Ver / Rev: 0 DRR: N/A

GS	10"	0.584"	Calibration:	Cal Time
Material	Size	Thick	Initial Cal:	<u>0750</u>
<u>Ultrason II</u>	<u>01225</u>		Cal Check:	<u>0805</u>
Couplant:	Couplant batch		Cal Check:	<u>0855</u>
<u>241880</u>	<u>68° F</u>		Final Cal:	<u>1102</u>
Thermometer S/N	Cal Temp.			

Search Unit Data

RTD 08-17Z 27x101 mm/Inch.
 Manufacturer: Serial Number Size/Shape:
0.32 in. 45° 44°
 Incident Point: Nominal Angle: Measured Angle:
2.0 MHz TBL2-Aval RL 2
 Frequency: Style: Mode: Elements:

Search Unit Cable

RG-174 6' 0
 Cable Type: Length: Connectors:

Instrument Settings

Panametrics / Epoch 4 031573611
 Manufacturer/Model: Serial Number:
7.535 MHz 0.236 in./mm 0.0 - 3.0
 Zero: Velocity: Narrowband Filter:
Auto Fullwave 2.0 in So / Max
 Rep Rate: Rectification: Range: Puser/Energy:
400 Ohms Off 2.0 MHz Dual
 Damping: Reject: Frequency: Mode:

DAC Construction

Scan Direction As
 Cal Reflector ID Notch
 Signal Amplitude 80%
 Signal Sweep: 5.9 Dtz
 Signal dB: 37.9 dB
 Sweep 0-10 = 1.5 in Metal Path

Calibration Verification

Field Simulator Block S/N: CAL-NW2-01Z

Reflector	<u>0.60"</u>	<u>N/A</u>
Amplitude	<u>80%</u>	<u>N/A</u>
Gain (dB)	<u>30.3</u>	<u>N/A</u>
Sweep (SD)	<u>5.9</u>	<u>N/A</u>

Acceptable Linearity performed: 4/15/2005

Exam Comments / Limitations:

Scanned downstream side only.
Did not scan on weld due to configuration.
Lift-off signals seen due to weld shrinkage.
Maintained a 20% ID roll during examination.

Exam Data for Weld: 14-B-10A

VALVE TO PIPE

Configuration:

OD 88° F 241880
 Exam Surface: Exam Temp. Exam Thermometer

Axial	UPST	Scan dB	Recordable	Exam
Circ	DNST		Indications	Angle
<u>Axial</u>	<u>DNST</u>	<u>43.9</u>	<u>NRI</u>	<u>45°</u>
<u>Circ</u>	<u>DNST</u>	<u>43.9</u>	<u>NRI</u>	<u>45°</u>

Exam Start: 0945 Exam End: 1025

RL

Randy Linden

III

Initials: Examiner:

Level:

N/A

N/A

Initials: Examiner 2:

Level:

Initial Cal/Exam Date: 4/28/2005

[Signature]

III

5-2-05

GE Reviewed By:

Level: Date:

[Signature] UT L.L. 5-2-05

Utility Reviewer

Date:

[Signature] 5/2/05

ANII Review:

Date:



GE ENERGY NUCLEAR

Ultrasonic Calibration and Examination Record Manual Piping and Components

Site/Unit: Pilgrim Nuclear Power Station / 1
Outage: RE-018

Report Number: APR-008
Data Sheet Number: UT-074
Linearity Sheet: L-008

Calibration Data for Block: PIL-115

Procedure: ENN-NDE-9.10

Ver / Rev: 0 DRR: N/A

CS	10"	0.594"	Calibration	Cal Time
Material	Size	Thick	Initial Cal:	0800
<u>Ultrason II</u>	<u>01228</u>		Cal Check:	0830
Couplant:	Couplant batch		Cal Check:	N/A
<u>241880</u>	<u>88° F</u>		Final Cal:	1100
Thermometer S/N	Cal Temp.			

Search Unit Data

RTD 08-179 207x10 mm Rect.
 Manufacturer: Serial Number Size/Shape:
0.32 in. 60° 60°
 Incident Point: Nominal Angle: Measured Angle:
2.0 MHz TRL-2-AWS Long 2
 Frequency: Style: Mode: Elements:

Search Unit Cable

RG-174 8' 0
 Cable Type: Length: Connectors:

Instrument Settings

Panemetrics / Epoch 4 031573811
 Manufacturer/Model: Serial Number:
8.155 MHz 0.222 in./sec. 0.8 - 3.0
 Zero: Velocity: Narrowband Filter:
Auto Fullwave 2.0 in Sa / Max
 Rep Rate: Rectification: Range: Pulsar/Energy:
400 Ohms Off 2.0 MHz Dual
 Damping: Reject: Frequency: Mode:

DAC Construction

Scan Direction: As
 Cal Reflector: ID Notch
 Signal Amplitude: 80%
 Signal Sweep: 5.9 Div
 Signal dB: 47.2 dB
 Sweep 0-10 = 2.0 in Metal Path

Calibration Verification

Field Simulator Block S/N: CAL-1W2-017

Reflector	<u>0.60"</u>	<u>N/A</u>
Amplitude	<u>80%</u>	<u>N/A</u>
Gain (dB)	<u>42.4</u>	<u>N/A</u>
Sweep (SD)	<u>8.0</u>	<u>N/A</u>

Acceptable Linearity performed: 4/15/2005

Exam Comments / Limitations:

Scanned downstream side only.
 Did not scan on weld due to configuration.
 *Weld shrinkage caused stiff signals, causing geometric reflectors.
 Maintained a 20 -30% ID roll during examination.

Exam Data for Weld: 14-B-10A

VALVE TO PIPE

Configuration:

OD 88° F 241880
 Exam Surface: Exam Temp. Exam Thermometer

Axial Circ	UPST DNST	Scan dB	Recordable Indications	Exam Angle
<u>Axial</u>	<u>DNST</u>	<u>47.2</u>	<u>NFI</u>	<u>60°</u>
<u>Circ</u>	<u>DNST</u>	<u>47.2</u>	<u>NFI</u>	<u>60°</u>

Exam Start: 0845 Exam End: 1028

R

Randy Linden

Initials: Examiner:

Level:

N/A

N/A

Initials: Examiner 2:

Level:

Initial Cal/Exam Date: 4/28/2005

[Signature] II 5-2-05
 GE Reviewed By: Level: Date:

[Signature] MT Lvl. II 5-2-05
 Utility Reviewer: Date:

[Signature] 5/3/05
 ANII Review: Date:

Page 6 of 6



GE ENERGY, NUCLEAR

EXAMINATION SUMMARY SHEET

Report No.: APR-007

Site: **Pilgrim Nuclear Power Station** Component ID: **2R-N1B-1**
 Outage: **RF-015** **NOZZLE TO SAFE END**
 System **RPV** ASME Cat.: **B-F** ASME Item **B5.10** Aug Req **IGSCC D**

Exams Performed	Data Sheet	Cal Sheet	Procedure	Calibration Block	Examination Personnel	Cert Level	Date
45° / RL	N/A	APC-001	TP04-016 (GE-UT-209) R1 (V17)	PIL-79	Richard Jasken	II	4/21/2005
45° / RL	N/A	APC-002	TP04-016 (GE-UT-209) R1 (V17)	PIL-79	Richard Jasken	II	4/21/2005
45° / S	N/A	APC-003	TP04-016 (GE-UT-209) R1 (V17)	PIL-79	Richard Jasken	II	4/21/2005
60° / RL	N/A	APC-004	TP04-016 (GE-UT-209) R1 (V17)	CAL-DPTH-083	Richard Jasken	II	4/21/2005
60° / RL	N/A	APC-006	TP04-016 (GE-UT-209) R1 (V17)	CAL-DPTH-083	Richard Jasken	II	4/21/2005
N/A	APD-001	N/A	TP04-016 (GE-UT-209) R1 (V17)	N/A	Richard Jasken	II	4/21/2005

Examination Results:

During the automated ultrasonic examination of the above referenced dissimilar metal weld, no indications associated with IGSCC or any reportable indications were recorded with the "SMART 2000" system utilizing a 45° shear wave and 45° & 60° refracted longitudinal wave search units.

The 45° shear wave examinations were performed from both the upstream and downstream sides of the weld. Root geometry, beam redirect and non-relevant indications were recorded.

The 45° RL wave examinations were performed from both the upstream and downstream sides of the weld. Root geometry, acoustic interface and non-relevant indications were recorded.

The 60° RL wave examinations were performed from both the upstream and downstream sides of the weld. Non-relevant indications were recorded.

Transducer lift off was observed at the carbon steel nozzle to butter interface due to the surface contour. Reference the data sheet for the parameters. Due to this lift off, the upstream circumferential scans are considered a best effort examination. 73% coverage was obtained per the procedure and 75% coverage of the code required examination volume.

Previous automated reports and drawings were reviewed prior to this summary.

Examination results were compared to data report 95-E-0643 from 1995 outage with No Change
 These examinations were performed under Work Order: 03116627 Change

This Summary and the following data sheets have been reviewed and accepted by the following personnel:

Prepared By: [Signature] Level: III Date: 4/23/05
 Utility Review: [Signature] Date: 4/26/05
 ANII Review: [Signature] Date: 4/29/05

RWP: 0082
Dose: 2200 mr.

Page 1 of 12

Page 126/240



GE ENERGY, NUCLEAR

Wall Thickness Profile Sheet

Site: Pilarim Nuclear Power Station Unit: 1

Report No.:

Project: RF-015

APR-007

System: RPV

Component ID Number: 2R-N1B-1

Position	0°	90°	180°	270°
1	1.90"	N/A	N/A	N/A
2	1.95"	N/A	N/A	N/A
3	2.05"	N/A	N/A	N/A
4	1.95"	N/A	N/A </td <td>N/A</td>	N/A
5	1.90"	N/A	N/A	N/A

Crown Height:

Crown Width: 1.95"

Nominal Diameter: 28.0"

Weld Length: 92.0"

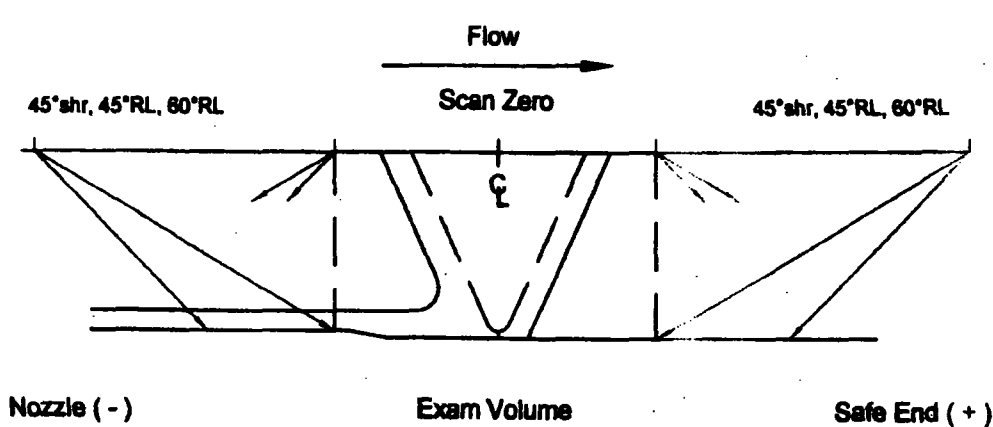
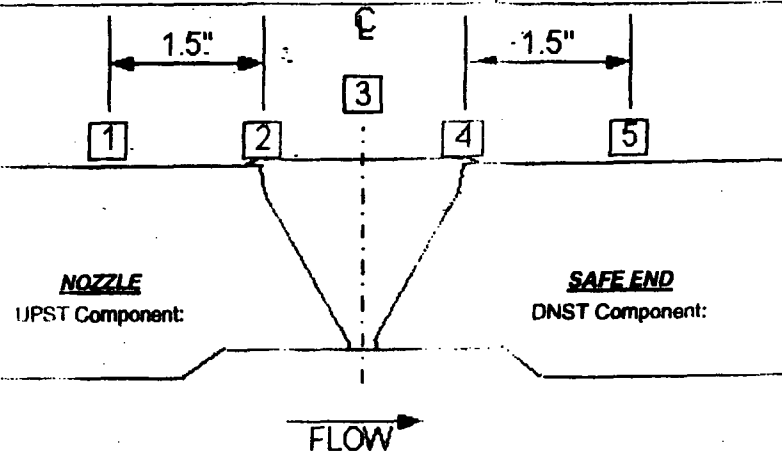

Thickness obtained from previous data
 Weld preps obtained from drawings; M1A80 and M1A73 sheet 2
 Scale - 1:2
 * - Concavity found at CS/Inc Interface. See page 3 of this report.

Page 127/240

CAR

Charles Barrett II 4/20/2005

Initials: Examiner: Level: Date:

GE Reviewed By: [Signature] Level: Date: 4-23-05

Utility Review: [Signature] Date: 4/26/05

ANII Review: [Signature] Date: 4/29/05



GE ENERGY, NUCLEAR

Indication / Coverage Plot Sheet

Site: Pilarim Nuclear Power Station Unit: 1

Report Number.:

Project: RF-015

APR-007

System: RPV

Component ID Number: 2R-N1B-1

Configuration: NOZZLE

SAFE END

NOZZLE

0°

CS / INC

SAFE END

90°

CS / INC

180°

CS / INC

270°

CS / INC

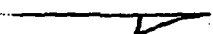
FLOW 

CS

Charles Barrett

II 4/20/2005

Initials: Examiner:

Level: Date:

M. K...

4/23/05

GE Reviewed By:

Level: Date:

Scott D...

4/20/05

Utility Reviewed By:

Date:

Carl...

4/20/05

ANII Reviewed By:

Date:

Page 128/140



N1B Nozzle to Safe End

45°RL LKUP Typical Geometry

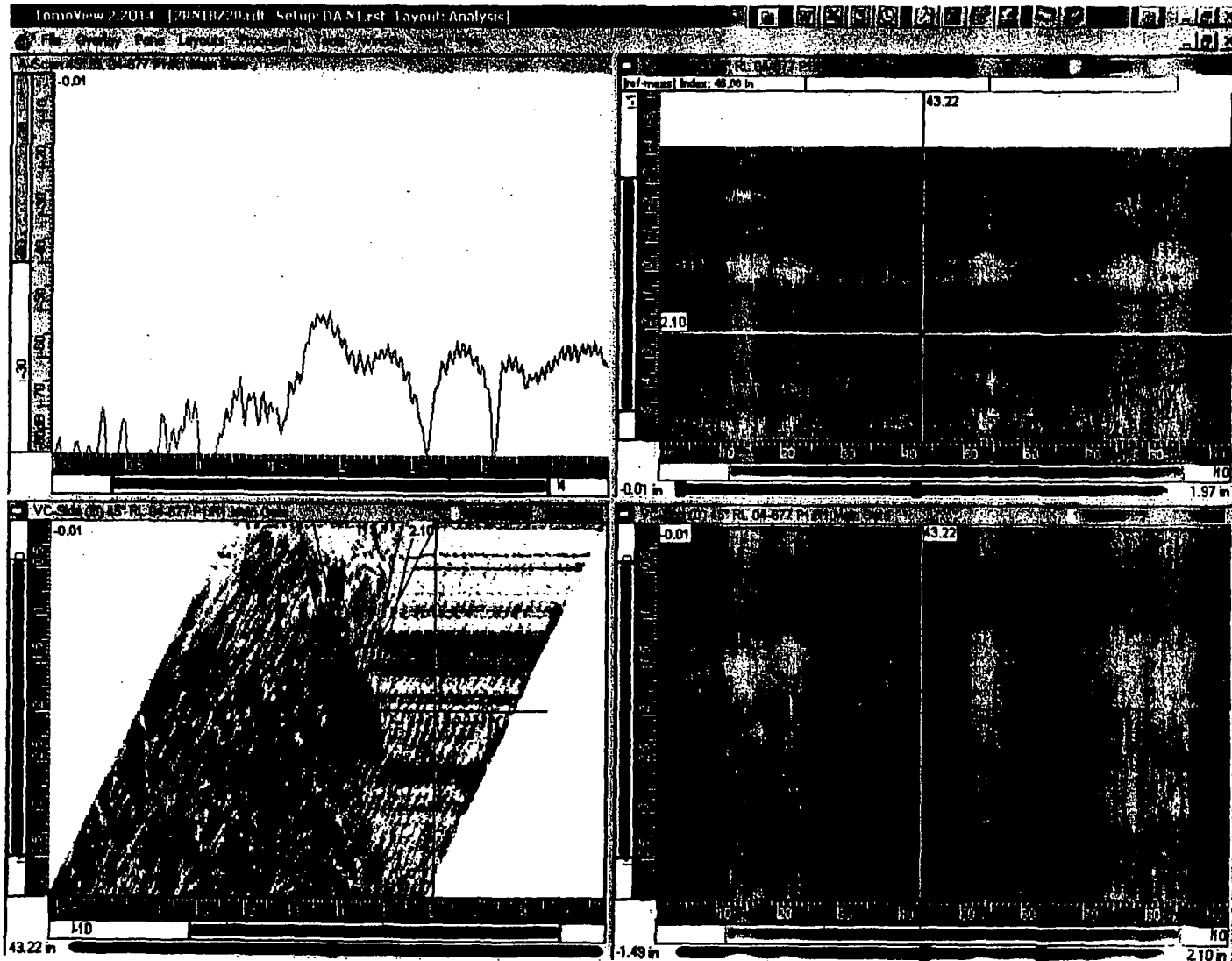

Page 129/240



N1B Nozzle to Safe End

45°Shear LKUP Typical Root Geometry

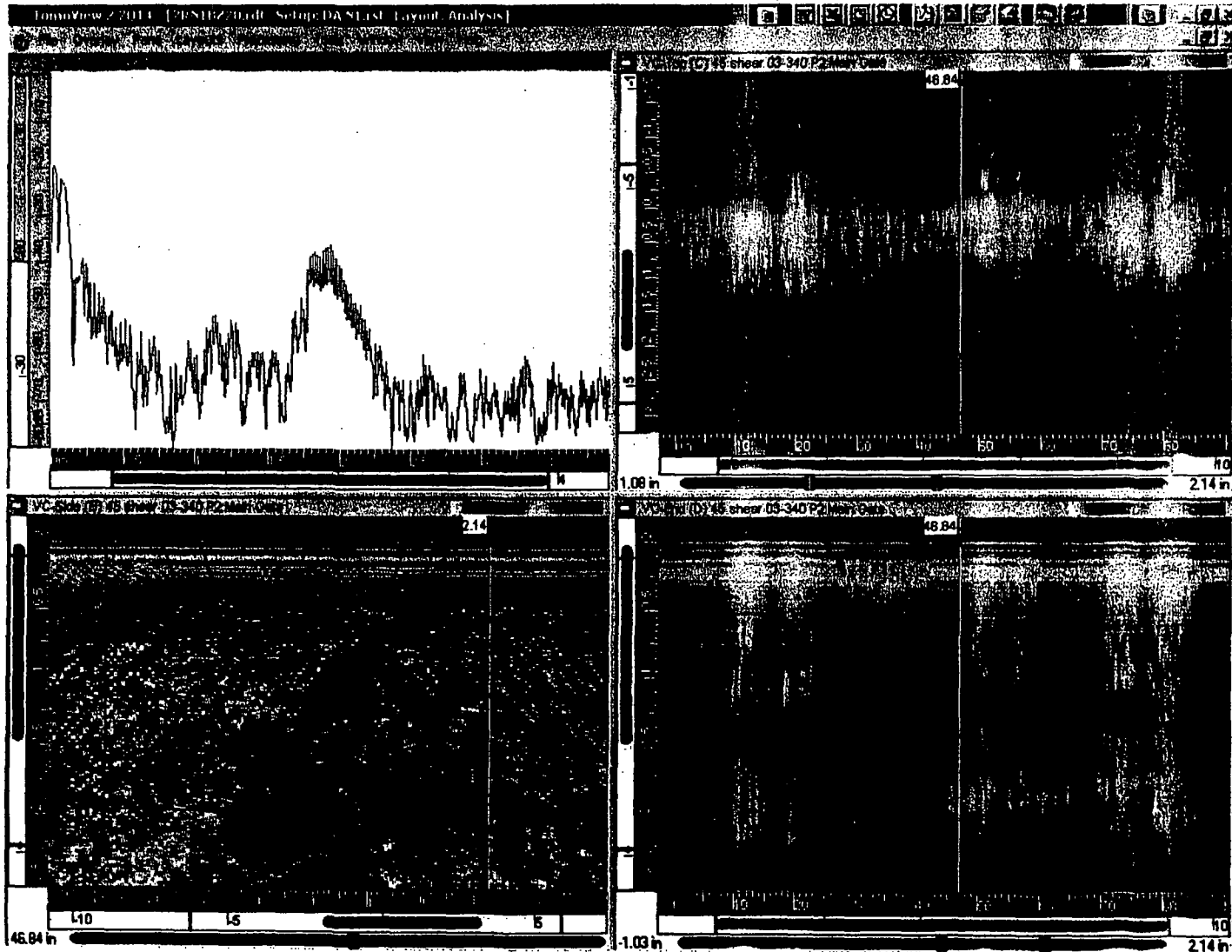

Page 130/140



GE Nuclear Energy

Ultrasonic Data / Scan Parameter Sheet
(Automated with Micro TomoScan)

Site: Pilgrim Nuclear Power Station
Unit: 1
Project No.: RF-015

Procedure: TP04-016 (GE-VT-209)
Version / Revision: R1 (V17)
DRR: NA

System: RPV
Weld No.: 2R-N1B-1
Configuration: NOZZLE TO SAFE END

Report No.: APR-007
Data Sheet No.: APD-001
Calibration Sheet No.

Scanner Information

Weld Reference, (GE-ADM-1005): Lo: Top Dead Center Wo: Weld Centerline Motor Steps: Cir: 1710 Tra: 2500
Examination Surface: OD Exam Surface Temperature: 84 °F Thermometer S/N: 241887 Exam Start: 4/21/2005 5:50:00 AM
Exam End: 4/22/2005 9:09:00 AM
Nominal Pipe Size 28" Nominal Thickness: 1.90" Weld Width: 1.93" Weld Length: 92"
Scanner: NOVA Track Diameter: 32" Arm Length: 18" Track Location: 8" DOWNSTREAM OF SE TAPER
X Positive Scan Direction: DOWNSTREAM Y Positive Scan Direction: CW
Resolution: ≤ 0.038" Index Ax / Circ: ≤ 0.19" ≤ 0.05" Axial Scan Speed: ≤ 2.0 in./Sec. Circ Scan Speed: ≤ 1.0 in./Sec.
Scanner Zero Positions: CIR: TOP DEAD CENTER TRA: WELD CENTERLINE ROT Zero: LKDN

Scan Parameters and Results

Scan:	Skew:	File ID:	Disk:	X-Start:	X-Stop:	Y-Start:	Y-Stop:	Gain:	Results:	Comments:
Z11	0	2RN1B1Z11	D-01	-5.6"	2.3"	0.0"	93.0"	Log	C,D,H,K	Bi-directional
Z20	180	2RN1B1Z20	D-02	-2.3"	5.7"	0.0"	93.0"	Log	C,D,H,K	Bi-directional
Z30	0	2RN1B1Z30	D-01	0.0"	93.0"	-3.7"	0.0"	Log	C	Uni-directional
Z31	0	2RN1B1Z31	D-02	0.0"	93.0"	0.0"	3.7"	Log	C	Uni-directional
Z40	180	2RN1B1Z40	D-03	0.0"	93.0"	-3.7"	0.0"	Log	C	Bi-directional
Z41	180	2RN1B1Z41	D-04	0.0"	93.0"	0.0"	3.7"	Log	C	Bi-directional

EXAMINATION RESULTS LEGEND

A - NO RECORDABLE INDICATIONS B - NON-GEOMETRIC INDICATIONS C - NON-RELEVANT INDICATIONS D - ACOUSTIC INTERFACE
 E - INSIDE SURFACE F - OUTSIDE SURFACE G - WELD DISCONTINUITY H - ROOT GEOMETRY
 I - COUNTERBORE J - SHEAR COMPONENT K - BEAM RE-DIRECT

Comments:

Axial scans were limited from a 'L' of 26" to 41.25" with a 'W' of -1.7" to -0.9" and a 'L' of 49" - 86" with a 'W' of -1.5" to 0".
Upstream circ scans were limited from a 'L' of 11" to 39" and 49.6" to 84".

Richard Jaska II 4/21/2005
Examiner: Level: Date:

GE Review: Level: Date: 4/23/05

Utility Review: Level: Date: 4/24/05

ANII Review: Level: Date: 4/26/05

Page 1 3/1/200



GE Energy, Nuclear

ULTRASONIC CALIBRATION DATA SHEET (Automated with Micro TomoScan)

Site Pilgrim Nuclear Power Unit 1 Project RF-015 Report Number APR-007 Calibration Sheet No. APC-001 Weld 2R-N1B-1

Procedure No. TP04-016 (GE-UT-209) Version R1 (V17) DRR N/A

Instrument Zetec / u Tomo 18121-09 2.2014 2.2014 Manufacturer / Model System Serial No. Acquisition Software Analysis Software Pulser/Receiver Main Board R/D Tech EQTX 100 R/D Tech EQTX 101 Digitizer: R/D Tech EQTX 098 Manufacturer / Model Manufacturer / Model Search Unit RTD 04-430 2(15x25) mm 1.0 Mhz 45 / RL 1.39 45 0.75 Manufacturer Serial No. Element Size Freq. (MHz) Angle / Mode FD,FS/SA,RA Measured Angle Incident to Wedge Front Cable RG-58/RG-58/RG-174 250' / 25' / 3' 2 No. of Intermediate Connectors Calibration Standard PIL-79 SS 2.1 2.1 Serial No. Material Nominal Thickness Measured Thickness Thermometer 241576 75 F Couplant Demin Water N/A Serial No. Temp (F) Type Batch No.

Table with 3 columns for Calibration data: Orientation (Circ), Type (ID Notch), Depth (2.10 in), Amplitude / dB (80%, -43.9 dB, -20.7 dB), Sweep (2.95 in), Gain (dB) (34, Log, +25 Log), Screen (Half Path, 25 dB Booster, Active).

Channel Name 45 RL 04-430 P1/R1 General Timebase Start 0.0 in. Range 5.5 in. Units Half Path

Digitizer Synchro Pulse A Scan Sample Size 8 Bit Averaging 1 Acquisition Rate 326 Hz Digitizing Frequency 6.25 MHz Max Recurrence 2000 Hz

Pulser / Receiver Configuration Conventional Pitch Catch Pulser P1 Receiver R1 Voltage 300 V Scale Type LOG Width (Ns) 500 ns Rectification Unsigned Smoothing 1 Mhz

Probe Wave Type Longitudinal Scan offset 0 in. Velocity 0.2272 in./sec. Index offset 0.00 in. Wedge Delay 12.229 usec. Angle 45 Skew 0/180

Field Simulator CS Rompage S/N CAL-RHOM-085 Reflector Far SDH Max Amplitude/dB -11.30 dB Sweep 1.06 Gain (dB) + Log

Table for Calibration Verification with columns: Time, Date, Block(s), Operator. Rows include Initial, Verified, and Final entries.

N1 - 45 RL - Circ scan

Richard Jasken II 4/21/2005 Operator Level Date Analyst [Signature] 4-23-05 Level Date

Utility Review [Signature] Level Date ANIII Review [Signature] Date

Page 132/240



GE Energy, Nuclear

ULTRASONIC CALIBRATION DATA SHEET (Automated with Micro TomoScan)

Site Pilgrim Nuclear Power Unit 1 Weld 2R-N1B-1

Project RF-015

Report Number APR-007 Calibration Sheet No. APC-002

Procedure No. TP04-016 (GE-UT-209)

Version R1 (V17) DRF N/A

Instrument Zetec / u Tomo 18121-09 2.2Q14 2.2Q14
Pulsar/Receiver R/D Tech EQTX 100 R/D Tech EQTX 101 R/D Tech EQTX 098
Search Unit RTD 03-677 2(20X34) mm 1.0 MHz 45° / RL 2.23° 45° 0.95°
Cable RG-58/RG-58/RG-174 250' / 25' / 3' 2
Calibration Standard PIL-79 SS 2.1" 2.1"
Thermometer 241576 75 °F Demin Water N/A

Table with 3 columns for Calibration parameters: Orientation, Type, Depth, Amplitude / dB, Sweep, Gain (dB), Screen.

Channel Name 45° RL 03-677 P1/R1
General Timebase Start 0.0 in. Range 5.5 in. Units Half Path
Digitizer Synchro Pulse A Scan Sample Size 8 Bit Averaging 1 Acquisition Rate 326 Hz Digitizing Frequency 6.25 MHz Max Recurrence 2000 Hz
Pulsar / Receiver Configuration Conventional Pitch Catch Pulsar P1 Receiver R1 Voltage 300 V Scale Type LOG Width (Ns) 500 ns Rectification Unstained Smoothing 1 MHz

Field Simulator CS Rompage S/N CAL-RHOM-095
Reflector Far SDH
Max Amplitude/dB -15.4 dB
Sweep 1.06"
Gain (dB) + Log

Probe Wave Type Longitudinal Scan offset 0 in. Velocity 0.2272 in./sec. Index offset 0.00 in. Wedge Delay 12.017 usec. Angle 45° Skew 0/180

Table for Calibration Verification with columns: Time, Date, Block(s), Operator. Rows: Initial, Verified, Verified, Verified, Final.

N1 - 45° RL - Ax scan

Richard Jasken II 4/21/2005 Operator Level Date Analyst 4-23-05 Level Date

Utility Review Level Date ANIII Review Level Date

Page 133/240



GE Energy, Nuclear

ULTRASONIC CALIBRATION DATA SHEET (Automated with Micro TomoScan)

Site Pilgrim Nuclear Power Unit 1 Project RF-015 Report Number APR-007 Calibration Sheet No. APC-003 Weld 2R-N1B-1

Procedure No. TP04-016 (GE-UT-209) Version R1 (V17) DRP N/A

Instrument Zetec / u Tomo 18121-08 2.2Q14 2.2Q14 Manufacturer / Model System Serial No. Acquisition Software Analysis Software Pulser/Receiver R/D Tech EQTX 100 R/D Tech EQTX 101 Digitizer: R/D Tech EQTX 098 Main Board: Manufacturer / Model Piggy Board: Manufacturer / Model Search Unit RTD 03-340 EII(24x17) mm 1.5 MHz 45°/S N/A 45° 0.52° Manufacturer Serial No. Element Size Freq. (MHz) Angle / Mode FD,FS/SA,RA Measured Incident to Wedge Front Cable RG-58/RG-58/RG-174 250' / 25' / 13' 2 No. of Intermediate Connectors Calibration Standard PIL-79 SS 2.1" 2.1" Serial No. Material Nominal Thickness Measured Thickness Thermometer 241576 75 °F Couplant Demin Water N/A Serial No. Temp (°F) Type Batch No.

Calibration Orientation Circ Type ID Notch Depth 2.10 in. Amplitude / dB -8.2 dB Sweep 2.97 in. Gain (dB) Log Screen Half Path 25 dB Booster Inactive

Channel Name 45° Shear 03-340 P2 General Timebase Start 0.0 in. Range 5.5 in. Units Half Path

Digitizer Synchro Pulse A Scan Sample Size 8 Bit Averaging 1 Acquisition Rate 326 Hz Digitizing Frequency 12.5 MHz Max Recurrence 2000 Hz

Pulser / Receiver Configuration Conventional Pulse Echo Pulser P2 Receiver N/A Voltage 300 V Scale Type LOG Width (Ns) 333 ns Rectification Unaligned Smoothing 2 MHz

Probe Wave Type Transverse Scan offset 0 in. Velocity 0.1240 in./sec. Index offset -2.50 in. Wedge Delay 11.951 usec. Angle 45° Skew 0/180

Field Simulator CS Rompas S/N CAL-RHOM-095 Reflector Far SDH Max Amplitude/dB -27.9 dB Sweep 1.03" Gain (dB) Log

Calibration Verification table with columns: Time, Date, Block(s), Operator. Rows: Initial (1250, 4/11/2005, PIL 79, RJ/MW), Verified (0555, 4/21/2005, CAL-RHOM-095, RSG), Verified (1410, 4/21/2005, CAL-RHOM-095, RJ), Verified (1332, 4/21/2005, CAL-RHOM-095, RSG), Final (0905, 4/22/2005, CAL-RHOM-095, RSG)

N1 - 45° Shear Ax scan index offset -2.50" Circ scan offset -2.50"

Richard Jasken II 4/21/2005 Operator Level Date Analyst [Signature] III 4-23-05 Level Date

[Signature] III 4/26/05 Utility Review Level Date [Signature] III 4/28/05 ANIII Review Level Date



GE Energy, Nuclear

ULTRASONIC CALIBRATION DATA SHEET (Automated with Micro TomoScan)

Site Pilgrim Nuclear Power Unit 1 Weld 2R-N1B-1

Project RF-015

Report Number APR-007 Calibration Sheet No. APC-004

Procedure No. TP04-016 (GE-UT-209)

Version R1 (V17) DRR N/A

Instrument Zetec / u Tomo 18121-09 2.2014 2.2014
Manufacturer / Model System Serial No. Acquisition Software Analysis Software
Pulsar/Receiver R/D Tech EQTX 100 Pulsar/Receiver R/D Tech EQTX 101 Digitizer: R/D Tech EQTX 098
Main Board: Manufacturer / Model Piggy Board: Manufacturer / Model Manufacturer / Model
Search Unit RTD 04-345 2(20x34) mm 1.0 MHz 60° / RL 1.38" 60° 1.0"
Manufacturer Serial No. Element Size Freq. (MHz) Angle / Mode FD,FS/SA,RA Measured Incident to
Cable RG-58/RG-58/RG-174 250' / 25' / 3' 2 No. of Intermediate Connectors Angle Wedge Front
Calibration Standard CAL-DPTH-063 SS 1.4" 1.4"
Serial No. Material Nominal Thickness Measured Thickness
Thermometer 241576 75 °F Couplant Demin Water N/A
Serial No. Temp (°F) Type Batch No.

Table with 3 columns for Calibration data: Orientation (Circ), Type (SDH), Depth (1.40 in), Amplitude / dB (80.8%, -30.7 dB, -6.6 dB), Sweep (2.78 in), Gain (dB) (21.0, Log, +25 Log), Screen (Half Path, 25 dB Booster, Active)

Channel Name 60° RL 04-345 P3 / R3
General
Timebase Start 0.0 in Range 8.0 in
Units Half Path

Digitizer
Synchro Pulse [X] A Scan Sample Size 8 Bit
Averaging 1 Acquisition Rate 326 Hz
Digitizing Frequency 6.25 MHz Max Recurrence 2000 Hz

Pulsar / Receiver
Configuration Conventional Pitch Catch
Pulsar P3 Receiver R3
Voltage 300 V Scale Type LOG
Width (Ns) 500 ns Rectification Unfiltered
Smoothing 1 MHz

Probe
Wave Type Longitudinal Scan offset 0 in
Velocity 0.2272 in/sec Index offset -5.00 in
Wedge Delay 13.593 usec Angle 60°
Skew 0/180

Field Simulator CS Rompas S/N CAL-RHOM-095
Reflector Far SDH
Max Amplitude/dB -11.9 dB
Sweep 1.56"
Gain (dB) + Log

Table for Calibration Verification with columns: Time, Date, Block(s), Operator. Rows include Initial, Verified, and Final entries.

N1 - 60° RL - Ax Scan

Richard Jasken II 4/21/2005
Operator Level Date
Analyst [Signature] III 4-23-05
Level Date

Utility Review [Signature] III 4/26/05
Level Date
ANIII Review [Signature] 4/26/05
Date

Page 135/240



GE Energy, Nuclear

ULTRASONIC CALIBRATION DATA SHEET (Automated with Micro TomoScan)

Site Pilgrim Nuclear Power Unit 1 Project RF-015 Report Number APR-007 Calibration Sheet No. APC-006 Weld 2R-N1B-1

Procedure No. TP04-016 (GE-UT-209) Version R1 (V17) DRR N/A

Instrument Zetes / uTomo 18121-09 2.2Q14 2.2Q14 Manufacturer / Model System Serial No. Acquisition Software Analysis Software Pulser/Receiver R/D Tech EQTX 100 R/D Tech EQTX 101 Digitizer: R/D Tech EQTX 098 Main Board: Manufacturer / Model Piggy Board: Manufacturer / Model Search Unit RTD 04-431 2(15x25) mm 1.0 MHz 60° / RL 0.89" 60° 0.75" Manufacturer Serial No. Element Size Freq. (MHz) Angle / Mode FD,FS/SA,RA Measured Incident to Cable RG-58/RG-58/RG-174 250' / 25' / 3' 2 No. of Intermediate Connectors Calibration Standard CAL-DPTH-063 SS 0.9" 0.9" Serial No. Material Nominal Thickness Measured Thickness Thermometer 241576 75 °F Couplant Demin Water N/A Serial No. Temp (°F) Type Batch No.

Table with 3 columns for Calibration parameters: Orientation (Circ), Type (SDH), Depth (0.90 in), Amplitude / dB (80.4%), Sweep (1.87 in), Gain (dB) (45.5), Screen (Half Path).

Channel Name 60° RL 04-431 P3 / R3 General Timebase Start 0.0 in. Range 8.0 in. Units Half Path

Digitizer Synchro Pulse A Scan Sample Size 8 Bit Averaging 1 Acquisition Rate 326 Hz Digitizing Frequency 6.25 MHz Max Recurrence 2000 Hz

Pulser / Receiver Configuration Conventional Pitch Catch Pulser P3 Receiver R3 Voltage 300 V Scale Type LOG Width (Ns) 500 ns Rectification Unsigned Smoothing 1 MHz

Probe Wave Type Longitudinal Scan offset -5 in. Velocity 0.2272 in./sec. Index offset 0.00 in. Wedge Delay 12.955 usec. Angle 60° Skew 0/180

Field Simulator CS Rompac S/N CAL-RHOM-095 Reflector Far SDH Max Amplitude/dB -33.6 dB Sweep 1.53° Gain (dB) + Log

Table for Calibration Verification with columns: Time, Date, Block(s), Operator. Rows include Initial, Verified, and Final dates and operators.

N1 - 60° RL - Circ Scan

Richard Jaskan Operator Level II Date 4/21/2005 Analyst Level III Date 4-23-05

Utility Review Level II Date 4/26/05 ANIII Review Level III Date 4/29/05

Page 136/240



GE Energy Nuclear

Micro-Tomo (Smart 2000) - Auto Piping Weld Examination Checklist

**Pilgrim Unit 1, 2005
2R-NIB-1**

2R1B1Z10 LKDN	Load appropriate setup	Offsets entered into TV correctly	Transducers Skewed IAW Procedure	Files named IAW Scanplan	360° contact achieved	360° Circ coverage achieved	Full Volume Ax Coverage Achieved	Scan saved to computer HD Verified readable	Data transferred to DA Verified received by DA	Data Reviewed	Analysis Complete	Package Complete	<u>NOTES:</u>
45° Shear	<input checked="" type="checkbox"/>	<input checked="" type="checkbox"/>	<input checked="" type="checkbox"/>	<input checked="" type="checkbox"/>	<input type="checkbox"/>	<input type="checkbox"/>	<input type="checkbox"/>	RJ	MJK	MJK	MJK	MJK	Lift off due to OD contour
45° RL	<input checked="" type="checkbox"/>	<input checked="" type="checkbox"/>	<input checked="" type="checkbox"/>	<input checked="" type="checkbox"/>	<input type="checkbox"/>	<input type="checkbox"/>							
60° RL	<input checked="" type="checkbox"/>	<input checked="" type="checkbox"/>	<input checked="" type="checkbox"/>	<input checked="" type="checkbox"/>	<input type="checkbox"/>	<input type="checkbox"/>							
2R1B1Z20 LKUP	Load appropriate setup	Offsets entered into TV correctly	Transducers Skewed IAW Procedure	Files named IAW Scanplan	360° contact achieved	360° Circ coverage achieved	Full Volume Ax Coverage Achieved	Scan saved to computer HD Verified readable	Data transferred to DA Verified received by DA	Data Reviewed	Analysis Complete	Package Complete	<u>NOTES:</u>
45° Shear	<input checked="" type="checkbox"/>	<input checked="" type="checkbox"/>	<input checked="" type="checkbox"/>	<input checked="" type="checkbox"/>	<input type="checkbox"/>	<input type="checkbox"/>	<input type="checkbox"/>	RJ	MJK	MJK	MJK	MJK	Lift off due to OD contour
45° RL	<input checked="" type="checkbox"/>	<input checked="" type="checkbox"/>	<input checked="" type="checkbox"/>	<input checked="" type="checkbox"/>	<input type="checkbox"/>	<input type="checkbox"/>							
60° RL	<input checked="" type="checkbox"/>	<input checked="" type="checkbox"/>	<input checked="" type="checkbox"/>	<input checked="" type="checkbox"/>	<input type="checkbox"/>	<input type="checkbox"/>							
2R1B1Z30 LKCW	Load appropriate setup	Offsets entered into TV correctly	Transducers Skewed IAW Procedure	Files named IAW Scanplan	360° contact achieved	360° Circ coverage achieved	Full Volume Ax Coverage Achieved	Scan saved to computer HD Verified readable	Data transferred to DA Verified received by DA	Data Reviewed	Analysis Complete	Package Complete	<u>NOTES:</u>
45° Shear	<input checked="" type="checkbox"/>	<input checked="" type="checkbox"/>	<input checked="" type="checkbox"/>	<input checked="" type="checkbox"/>	<input type="checkbox"/>	<input type="checkbox"/>	<input type="checkbox"/>	MW	MJK	MJK	MJK	MJK	Lift off due to OD contour on upstream side
45° RL	<input checked="" type="checkbox"/>	<input checked="" type="checkbox"/>	<input checked="" type="checkbox"/>	<input checked="" type="checkbox"/>	<input type="checkbox"/>	<input type="checkbox"/>							
60° RL	<input checked="" type="checkbox"/>	<input checked="" type="checkbox"/>	<input checked="" type="checkbox"/>	<input checked="" type="checkbox"/>	<input type="checkbox"/>	<input type="checkbox"/>							
2R1B1Z40 LKCCW	Load appropriate setup	Offsets entered into TV correctly	Transducers Skewed IAW Procedure	Files named IAW Scanplan	360° contact achieved	360° Circ coverage achieved	Full Volume Ax Coverage Achieved	Scan saved to computer HD Verified readable	Data transferred to DA Verified received by DA	Data Reviewed	Analysis Complete	Package Complete	<u>NOTES:</u>
45° Shear	<input checked="" type="checkbox"/>	<input checked="" type="checkbox"/>	<input checked="" type="checkbox"/>	<input checked="" type="checkbox"/>	<input type="checkbox"/>	<input type="checkbox"/>	<input type="checkbox"/>	MW	MJK	MJK	MJK	MJK	Lift off due to OD contour on upstream side
45° RL	<input checked="" type="checkbox"/>	<input checked="" type="checkbox"/>	<input checked="" type="checkbox"/>	<input checked="" type="checkbox"/>	<input type="checkbox"/>	<input type="checkbox"/>							
60° RL	<input checked="" type="checkbox"/>	<input checked="" type="checkbox"/>	<input checked="" type="checkbox"/>	<input checked="" type="checkbox"/>	<input type="checkbox"/>	<input type="checkbox"/>							

Notes: Circ scans separated to upstream and downstream sides of weld centerline.

Page 137/240

Sam DeWitt
Date 12 of 12



GE ENERGY, NUCLEAR

EXAMINATION SUMMARY SHEET

Report No.: APR-009

Site: Pilgrim Nuclear Power Station Component ID: 2R-N2E-1
 Outage: RF-015 SAFE END TO NOZZLE
 System RPV ASME Cat.: B-F ASME Item B5.10 Aug Req IGSCC D

Exams Performed	Data Sheet	Cal Sheet	Procedure	Calibration Block	Examination Personnel	Cert Level	Date
45° / S	N/A	APC-071	TP04-016 (GE-UT-209) R1 (V17)	PIL-7E	Robert Scott Getz	II	4/22/2005
45° / RL	N/A	APC-072	TP04-016 (GE-UT-209) R1 (V17)	PIL-7B	Robert Scott Getz	II	4/22/2005
45° / RL	N/A	APC-073	TP04-016 (GE-UT-209) R1 (V17)	PIL-7B	Robert Scott Getz	II	4/22/2005
60° / RL	N/A	APC-074	TP04-016 (GE-UT-209) R1 (V17)	CAL-DPTH-063	Robert Scott Getz	II	4/22/2005
60° / RL	N/A	APC-075	TP04-016 (GE-UT-209) R1 (V17)	CAL-DPTH-063	Robert Scott Getz	II	4/22/2005
N/A	APD-005	N/A	TP04-016 (GE-UT-209) R1 (V17)	N/A	Robert Scott Getz	II	4/22/2005

Examination Results:

During the automated ultrasonic examination of the above referenced dissimilar metal weld, no indications associated with IGSCC or any reportable indications were recorded with the "SMART 2000" system utilizing a 45° shear wave, 45° and 60° refracted longitudinal wave search units.

The 45° shear wave examinations were performed from both the upstream and downstream sides of the weld. Root geometry, beam redirect and non-relevant indications were recorded.

The 45° RL wave examinations were performed from both the upstream and downstream sides of the weld. Root geometry, acoustic interface, inside surface geometry and non-relevant indications were recorded.

The 60° RL wave examinations were performed from both the upstream and downstream sides of the weld. Acoustic interface and non-relevant indications were recorded.

The outside surface weld crown did not meet procedure requirements from 11° to 23°. 79.1% coverage was obtained per the procedure and 81.2% coverage of the code required examination volume.

Previous automated electronic data and automated reports and drawings were reviewed prior to this summary.

Examination results were compared to data report 95-E-403 from 1995 outage with No Change
 These examinations were performed under Work Order: 031166227 Change

This Summary and the following data sheets have been reviewed and accepted by the following personnel:

Prepared By: [Signature] Level: III Date: 4-25-05 Utility Review: [Signature] Date: 4/28/05
 ANII Review: [Signature] Date: 4/28/05

RWP: 0082
Dose: 1850 mr.

Page 1 of 13



GE ENERGY, NUCLEAR

Wall Thickness Profile Sheet

Site: Pilgrim Nuclear Power Station Unit: 1

Report No.: APR-009

Project: RF-015

System: RPV

Component ID Number: 2R-N2E-1

Position	0°	90°	180°	270°
1	1.09"	N/A	N/A	N/A
2	1.20"	N/A	N/A	N/A
3	1.21"	N/A	N/A </td <td>N/A</td>	N/A
4	1.08"	N/A	N/A	N/A
5	1.09"	N/A	N/A	N/A

Crown Height: FLUSH

Crown Width: 1.15"

Nominal Diameter: 12.0"

Weld Length: 42.0"

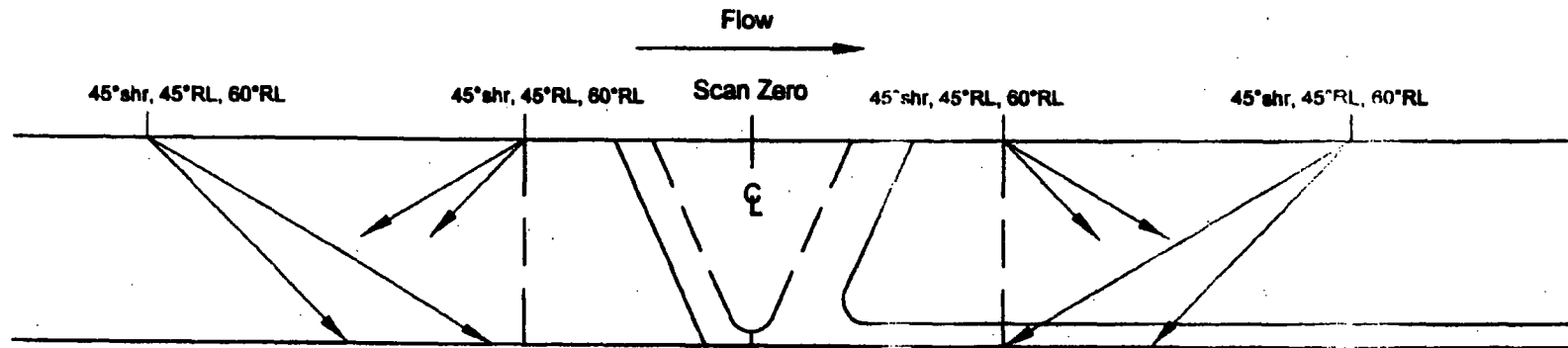
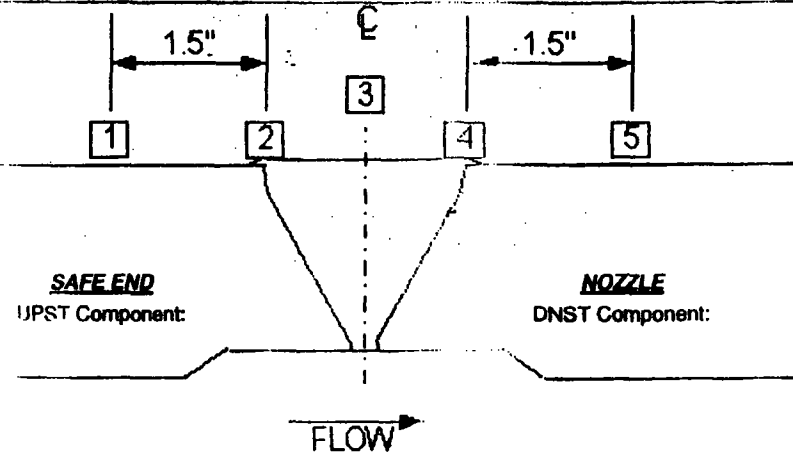

Safe End (-)

Procedural Exam Volume

Nozzle (+)

Thickness obtained from previous data

Weld preps obtained from drawings; 137C8066 and M1A73 sheet 2

Bottom of nozzle bore to Inc/CS interface = 4.1"

Bottom of SE taper to Inc/CS interface = 7.5"

Req 139/240

CB Charles Barrett II 4/25/2005
 Initials: Examiner: Level: Date:

[Signature] 4/25/05
 GE Reviewed By: Level: Date:

[Signature] 4/25/05
 Utility Review: Date:

[Signature] 4/25/05
 ANII Review: Date:



GE ENERGY, NUCLEAR

Wall Thickness Profile Sheet

Site: Pilarim Nuclear Power Station Unit: 1

Report No.: APR-009

Project: RF-015

APR-009

System: RPV

Component ID Number: 2R-N2E-1

Position	0°	90°	180°	270°
1	1.09"	N/A	N/A	N/A
2	1.20"	N/A	N/A	N/A
3	1.21"	N/A </td <td>N/A</td> <td>N/A</td>	N/A	N/A
4	1.08"	N/A	N/A	N/A
5	1.09"	N/A	N/A	N/A

Crown Height: FLUSH

Crown Width: 1.15"

Nominal Diameter: 12.0"

Weld Length: 42.0"

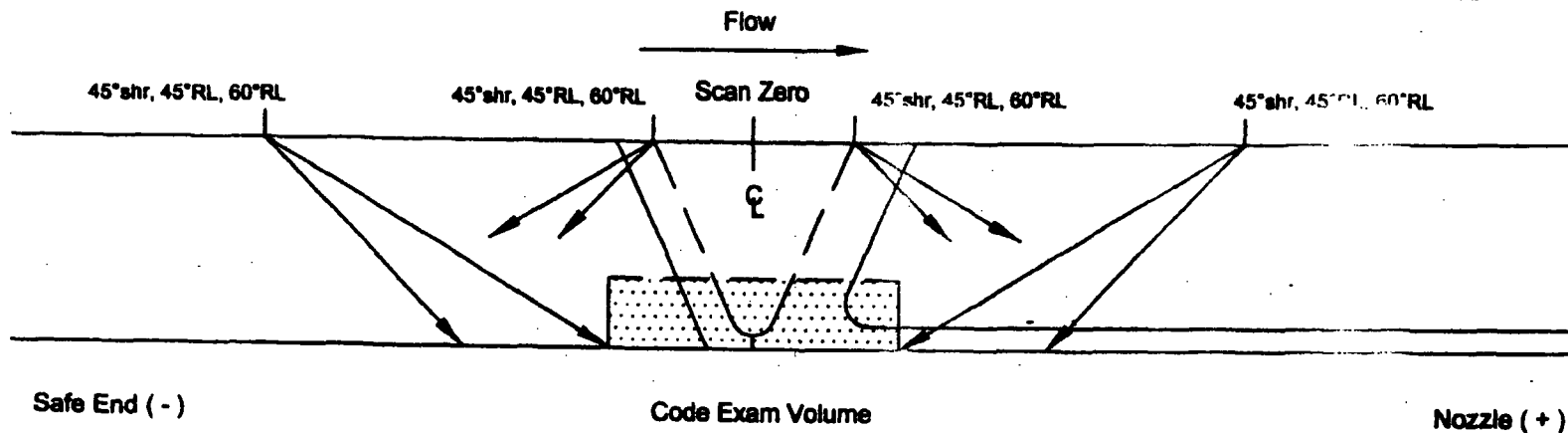
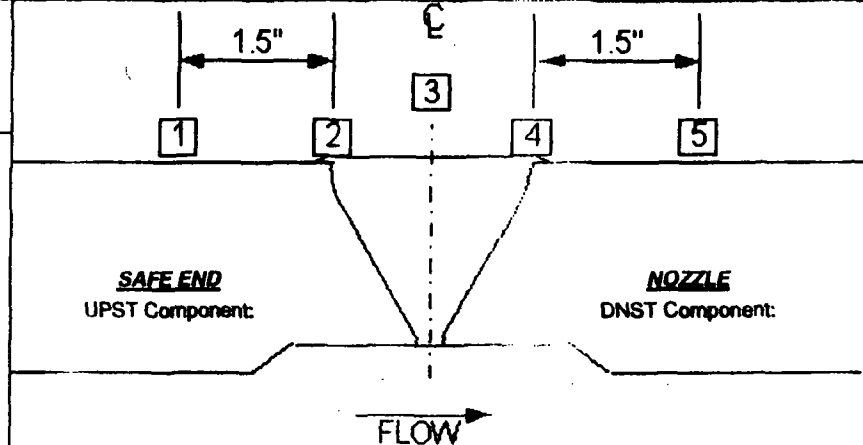

Thickness obtained from previous data
 Weld preps obtained from drawings; 137C8066 and M1A73 sheet 2
 Bottom of nozzle bore to Inc/CS interface = 4.1"
 Bottom of SE taper to Inc/CS interface = 7.5"

Page 140/24-0

CB

Charles Barrett II 4/25/2005
Initials: Examiner: Level: Date:

M. J. ... 4/25/05
GE Reviewed By: Level: Date:

Scott ... 4/25/05
Utility Review: Date:

... 4/25/05
ANII Review: Date:



GE ENERGY, NUCLEAR

Indication / Coverage Plot Sheet

Site: Pillar Nuclear Power Station Unit: 1

Report Number.:

Project: RF-016

APR-009

System: RPV

Component ID Number: 2R-N2E-1

Configuration: SAFE END

NOZZLE

0°

INC/CS



90°

INC/CS



180°

INC/CS



270°

INC/CS



Page 14/240

CAB Charles Barrett II 4/25/2005
Initials: Examiner: Level: Date:

[Signature] TL 4.25.05
GE Reviewed By: Level: Date:

[Signature] L-III 4/26/05
Utility Reviewed By: Date:

[Signature] 4/26/05
ANII Reviewed By: Date:



N2E Safe End to Nozzle

45°RL LKDN Root Geometry

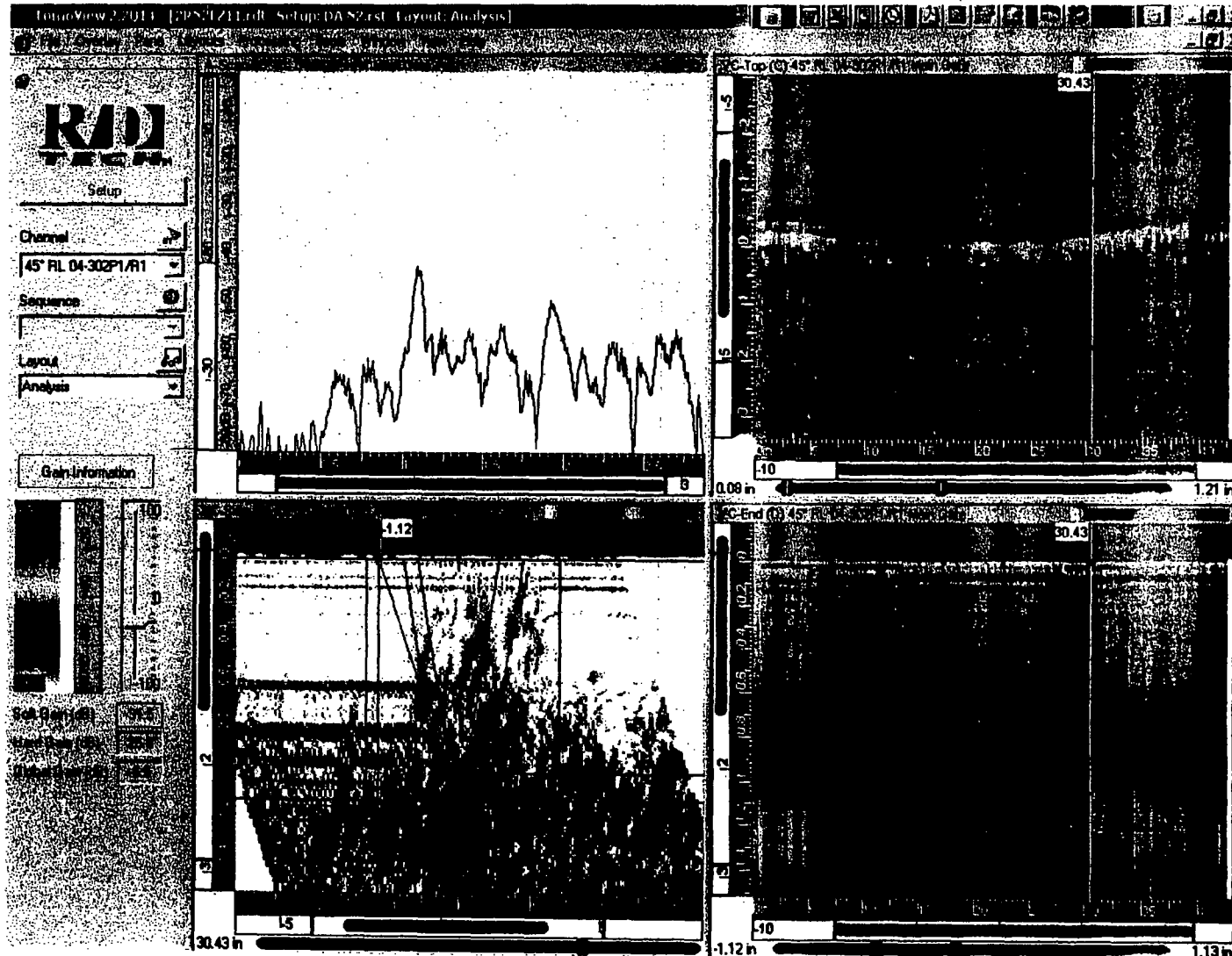

Page 142/240



N2E Safe End to Nozzle

45°RL LKDN Acoustic Interface

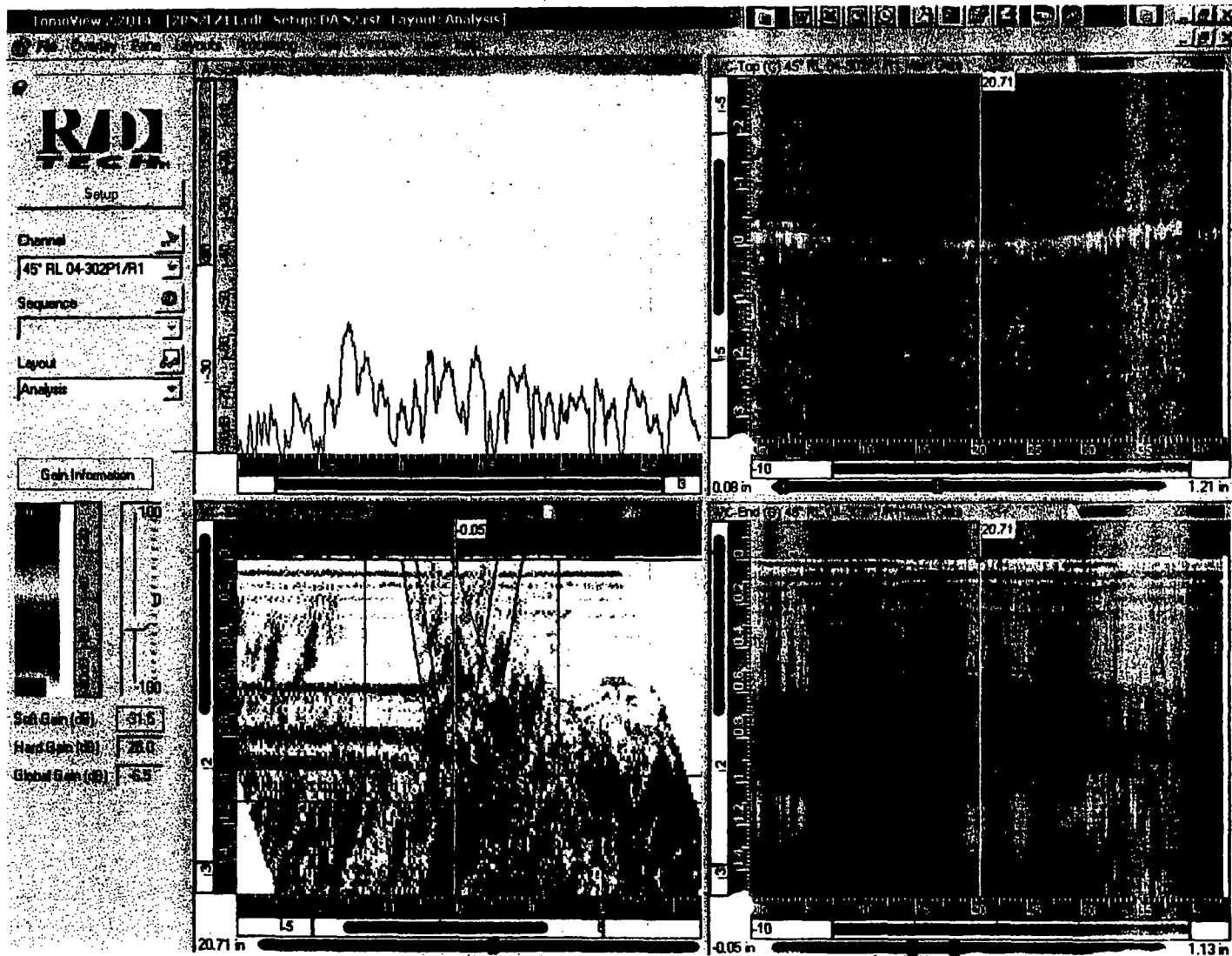

Boqz 143/240



GE Nuclear Energy

Ultrasonic Data / Scan Parameter Sheet
(Automated with Micro TomoScan)

Site: <u>Pilaris Nuclear Power Station</u>	Procedure: <u>TP04-016 (GE-UT-209)</u>	System: <u>RPV</u>	Report No.: <u>APR-009</u>
Unit: <u>1</u>	Version / Revision: <u>R1 (V17)</u>	Weld No.: <u>2R-N2E-1</u>	Data Sheet No.: <u>APD-005</u>
Project No.: <u>RF-015</u>	DRR: <u>N/A</u>	Configuration: <u>SAFE END TO NOZZLE</u>	Calibration Sheet No.

Scanner Information

Weld Reference, (GE-ADM-1005): Lo: IDC Wo: Weld Centerline Motor Steps: Cir: 2098 Tra: 2500
 Examination Surface: OD Exam Surface Temperature: 92 °F Thermometer S/N: 241878 Exam Start: 4/22/2005 3:25:00 PM
 Exam End: 4/23/2005 7:20:00 AM
 Nominal Pipe Size 12" Nominal Thickness: 1.1" Weld Width: 1.12" Weld Length: 42"
 Scanner: NOVA Track Diameter: 16" Arm Length: 18" Track Location: 14" FROM INTERFACE UPSTREAM
 X Positive Scan Direction: CW Y Positive Scan Direction: DOWNSTREAM
 Resolution: ≤ 0.036" Index Ax / Circ: ≤ 0.16" ≤ 0.05" Axial Scan Speed: ≤ 1.98 in./Sec. Circ Scan Speed: ≤ 0.98 in./Sec.
 Scanner Zero Positions: CIR: TOP DEAD CENTER TRA: WELD CENTERLINE ROT Zero: LOOKING DOWNSTREAM

Scan Parameters and Results

Scan:	Skew:	File ID:	Disk:	X-Start:	X-Stop:	Y-Start:	Y-Stop:	Gain:	Results:	Comments:
Z11	0	2RN2EZ11	D-09	-4.0"	2.1"	0.0"	43.0"	Log	C.D.H	Uni-directional
Z20	180	2RN2EZ20	D-09	-2.0"	4.1"	0.0"	43.0"	Log	K.C	Bi-directional
Z30	0	2RN2EZ30	D-09	0.0"	43.0"	-2.7"	2.9"	Log	C	Uni-directional
Z40	180	2RNZEZ40	D-09	0.0"	43.0"	-2.7"	2.9"	Log	C.E	Uni-directional

EXAMINATION RESULTS LEGEND

A - NO RECORDABLE INDICATIONS B - NON-GEOMETRIC INDICATIONS C - NON-RELEVANT INDICATIONS D - ACOUSTIC INTERFACE
 E - INSIDE SURFACE F - OUTSIDE SURFACE G - WELD DISCONTINUITY H - ROOT GEOMETRY
 I - COUNTERBORE J - SHEAR COMPONENT K - BEAM RE-DIRECT

Comments:

High weld crown from a 'L' of 11"- 23" does not meet procedure requirements.
 Load A01 files for Z11 and Z20 scans.

Robert Scott Getz II 4/22/2005 *[Signature]* 4.25 45 *[Signature]* 4/28/05 *[Signature]* 4/28/05
 Examiner: Level: Date: GE Review: Level: Date: Utility Review: Date: ANII Review: Date:

Page 144/240



GE Energy, Nuclear

ULTRASONIC CALIBRATION DATA SHEET (Automated with Micro TomoScan)

Site Pilgrim Nuclear Power Unit 1

Project RF-015

Report Number APR-009

Calibration Sheet No. APC-071

Weld 2R-N2E-1

Procedure No. TP04-016 (GE-UT-209)

Version R1 (V17) DRF N/A

Instrument Zetec / u Tomo 18121-08 2.2014 2.2014
 Manufacturer / Model System Serial No. Acquisition Software Analysis Software

Pulsar/Receiver R/D Tech EQTX 100 Pulsar/Receiver R/D Tech EQTX 101 Digitizer: R/D Tech EQTX 098
 Main Board: Manufacturer / Model Piggy Board: Manufacturer / Model Manufacturer / Model

Search Unit RTD 03-341 Ell(24x17)mm 1.5 MHz 45° / S N/A 45° 0.52°
 Manufacturer Serial No. Element Size Freq. (MHz) Angle / Mode FD,FS/SA,RA Measured Incident to Wedge Front

Cable RG-58/RG-59/RG-174 250' / 25' / 3' 2
 Type Length No. of Intermediate Connectors

Calibration Standard PIL-78 SS 1.3" 1.3"
 Serial No. Material Nominal Thickness Measured Thickness

Thermometer 241878 75 °F Demin Water N/A
 Serial No. Temp (°F) Couplant Type Batch No.

Calibration

Orientation Circ Circ
 Type ID Notch ID Notch
 Depth 1.30 in. 1.30 in.
 Amplitude / dB 85.4% -9.4 dB
 Sweep 1.91 in. 1.91 in.
 Gain (dB) 1.0 Log
 Screen Half Path 25 dB Booster Inactive

Channel Name 03-341 45° Shear P2

General

Timebase Start 0.0 in. Range 4.0 in.
 Units Half Path

Digitizer

Synchro Pulse A Scan Sample Size 8 Bit
 Averaging 1 Acquisition Rate 301 Hz
 Digitizing Frequency 12.5 MHz Max Recurrence 2000 Hz

Pulsar / Receiver

Configuration Conventional Pulse Echo
 Pulsar P2 Receiver N/A
 Voltage 300 V Scale Type LOG
 Width (Ns) 333 ns Rectification Unsigned
 Smoothing 2 MHz

Field Simulator CS Romoss S/N CAL-RHOM-095

Reflector Far SDH
 Max Amplitude/dB -19.5 dB
 Sweep 1.01"
 Gain (dB) Log

Probe

Wave Type Transverse Scan offset 0.00 in.
 Velocity 0.1240 in./sec. Index offset 0.00 in.
 Wedge Delay 11.778 usec. Angle 45°
 Skew 0/180

Calibration Verification

	Time	Date	Block(s)	Operator
Initial	0847	4/11/2005	PIL 78	RJ
Verified	1528	4/22/2005	CAL-RHOM-095	SG
Verified	2224	4/22/2005	CAL-RHOM-095	MW
Verified	1030	4/23/2005	CAL-RHOM-095	RJ
Final	0120	4/24/2005	CAL-RHOM-095	PK

N2 - 45° Shear - Ax/Circ Scan
 Ax scan offset: 0 Index offset: -2.60
 Circ scan offset: -2.60 Index offset: 0
 Calibration verification at 1703, 4/23/04, Block CAL-RHOM-095

Robert Scott Getz II 4/22/2005
 Operator Level Date
 Analyst [Signature] III 4-25-05
 Level Date

[Signature] III 4/28/05
 Utility Review Level Date
[Signature] III 4/28/05
 ANIII Review Date



GE Energy, Nuclear

ULTRASONIC CALIBRATION DATA SHEET (Automated with Micro TomoScan)

Site Pilgrim Nuclear Power Unit 1 Project RF-015 Report Number APR-009 Calibration Sheet No. APC-072 Weld 2R-N2E-1

Procedure No. TP04-016 (GE-UT-209) Version R1 (V17) DRF N/A

Instrument Zetec / uTomo 18121-09 2.2014 2.2014 Manufacturer / Model System Serial No. Acquisition Software Analysis Software Pulser/Receiver Main Board: R/D Tech EQTX 100 R/D Tech EQTX 101 Digitizer: R/D Tech EQTX 098 Manufacturer / Model Manufacturer / Model Search Unit RTD 04-302 2(10x18) mm 2.0 MHz 45° / RL 1.0° 45° 0.55" Manufacturer Serial No. Element Size Freq. (MHz) Angle / Mode FD,FS/SA,RA Measured Angle Incident to Wedge Front Cable RG-58/RG-58/RG-174 250' / 25' / 3' Length 2 No. of Intermediate Connectors Calibration Standard PIL-78 SSING 1.3" 1.3" Serial No. Material Nominal Thickness Measured Thickness Thermometer 241878 75 °F Couplant Demin Water N/A Serial No. Temp (°F) Type Batch No.

Table with 3 columns for Calibration data: Orientation (Circ), Type (ID Notch), Depth (1.30 in), Amplitude / dB (82.4%, -32.0 dB, -7.2 dB), Sweep (1.85 in), Gain (dB) (23.0, Log, +25 Log), Screen (Half Path, 25 dB Booster, Active)

Channel Name 45° RL 04-302 P1/R1 General Timebase Start 0.0 in Range 4.0 in Units Half Path

Digitizer Synchro Pulse A Scan Sample Size 8 Bit Averaging 1 Acquisition Rate 301 Hz Digitizing Frequency 12.5 MHz Max Recurrence 2000 Hz

Pulser / Receiver Configuration Conventional Pitch Catch Pulser P1 Receiver R1 Voltage 300 V Scale Type LOG Width (Ns) 250 ns Rectification Unsigned Smoothing 2 MHz

Probe Wave Type Longitudinal Scan offset 0.00 in Velocity 0.2272 in./sec. Index offset 0.00 in Wedge Delay 9.675 usec. Angle 45° Skew 0/180

Field Simulator CS Rompas S/N CAL-RHOM-095 Reflector Far SDH Max Amplitude/dB -5.3 dB Sweep 1.04" Gain (dB) Log

Table for Calibration Verification with columns: Time, Date, Block(s), Operator. Rows: Initial (0900, 4/11/2005, PIL 78, RJ), Verified (1528, 4/22/2005, CAL-RHOM-095, SG), Verified, Verified, Final (2223, 4/22/2005, CAL-RHOM-095, MW)

N2 - 45° RL - Ax Scan

Robert Scott Getz II 4/22/2005 Operator Level Date Analyst [Signature] 4.25.05 Level Date

Utility Review [Signature] Level Date ANIII Review [Signature] Date



GE Energy, Nuclear

ULTRASONIC CALIBRATION DATA SHEET (Automated with Micro TomoScan)

Site Pilgrim Nuclear Power Unit 1 Project RF-015 Report Number APR-009 Calibration Sheet No. APC-073 Weld 2R-N2E-1

Procedure No. TP04-016 (GE-UT-209) Version: R1 (V17) DRR N/A

Instrument Zetec / uTomo 18121-09 2.2014 2.2014 Manufacturer / Model System Serial No. Acquisition Software Analysis Software
Pulsar/Receiver Main Board: R/D Tech EQTX 100 R/D Tech EQTX 101 Digitizer: R/D Tech EQTX 098
Search Unit RTD 04-310 2(10x18) mm 1.0 MHz 45°/RL 0.84° 45° 0.55°
Cable RG-58/RG-58/RG-174 250' / 25' / 3' 250' / 25' / 3' 250' / 25' / 3'
Calibration Standard PNL-78 SS/NG 1.3" 1.3"
Thermometer 241878 75 °F 241878 75 °F

Table with 3 columns for Calibration parameters: Orientation, Type, Depth, Amplitude / dB, Sweep, Gain (dB), Screen. Values include Circ, ID Notch, 1.30 in., 83.9%, 1.85 in., 37, Half Path.

Channel Name 45° RL 04-310 P1/R1
General
Timebase Start 0.0 in. Range 4.0 in.
Units Half Path

Digitizer
Synchro Pulse [X] A Scan Sample Size 8 Bit
Averaging 1 Acquisition Rate 301 Hz
Digitizing Frequency 6.25 MHz Max Recurrence 2000 Hz

Pulsar / Receiver
Configuration Conventional Pitch Catch
Pulsar P1 Receiver R1
Voltage 300 V Scale Type LOG
Width (Ns) 500 ns Rectification Unsigned Smoothing 1 MHz

Probe
Wave Type Longitudinal Scan offset 0.00 in.
Velocity 0.2272 in./sec. Index offset 0.00 in.
Wedge Delay 12.318 usec. Angle 45° Skew 0/180

Field Simulator CS Romoss S/N CAL-RHOM-095
Reflector Far SDH
Max Amplitude/dB -17.3 dB
Sweep 1.0"
Gain (dB) + Log

Table for Calibration Verification with columns: Time, Date, Block(s), Operator. Rows include Initial, Verified, and Final entries.

N2 - 45° RL - Circ Scan

Robert Scott Getz II 4/22/2005 Operator Level Date
Analyst [Signature] III 4-25-05 Level Date

[Signature] III 7/25/05 Utility Review Level Date
[Signature] III 4/25/05 ANIII Review Level Date

Page 147/240



GE Energy, Nuclear

ULTRASONIC CALIBRATION DATA SHEET (Automated with Micro TomoScan)

Site Pilgrim Nuclear Power Unit 1 Project RF-015 Report Number APR-009 Calibration Sheet No. APC-074 Weld 2R-N2E-1

Procedure No. TP04-016 (GE-UT-209) Version R1 (V17) DRF N/A

Instrument Zetes / uTomo 18121-02 2.2Q14 2.2Q14 Manufacturer / Model System Serial No. Acquisition Software Analysis Software
Pulser/Receiver Main Board: R/D Tech EQTX 100 R/D Tech EQTX 101 Digitizer: R/D Tech EQTX 098
Search Unit RTD 04-305 2(10x18)mm 2.0 MHz 60°/RL 0.77" 61° 0.52" Manufacturer Serial No. Element Size Freq. (MHz) Angle / Mode FD,FS/SA,RA Measured Angle Incident to Wedge Front
Cable RG-58/RG-58/RG-174 250' / 25' / 3' Length 2 No. of Intermediate Connectors
Calibration Standard CAL-DPTH-063 SS 0.8" 0.8" Serial No. Material Nominal Thickness Measured Thickness
Thermometer 241878 75 °F Couplant Demin Water N/A Serial No. Temp (°F) Type Batch No.

Table with 3 columns for Calibration parameters: Orientation (Circ), Type (SDH), Depth (0.80 in), Amplitude / dB (81.5%, -33.9 dB, -9.4 dB), Sweep (1.65 in), Gain (dB) (24, Log, +25 Log), Screen (Half Path, 25 dB Booster, Active)

Channel Name 60° RL 04-305 P3 / R3
General
Timebase Start 0.0 in Range 5.5 in Units Half Path
Digitizer
Synchro Pulse [x] A Scan Sample Size 8 BR
Averaging 1 Acquisition Rate 301 Hz
Digitizing Frequency 12.5 MHz Max Recurrence 2000 Hz
Pulser / Receiver

Field Simulator CS Rompas S/N CAL-RHOM-095
Reflector Far SDH
Max Amplitude/dB -7.2 dB
Sweep 1.55"
Gain (dB) + Log

Configuration Conventional Pitch Catch
Pulser P3 Receiver R3
Voltage 300 V Scale Type LOG
Width (Ns) 250 ns Rectification Unsigned Smoothing 2 MHz
Probe

Table for Calibration Verification with columns: Time, Date, Block(s), Operator. Rows include Initial, Verified, Verified, Verified, Final.

Wave Type Longitudinal Scan offset 0.00 in
Velocity 0.2272 in/sec Index offset -5.20 in
Wedge Delay 10.637 usec Angle 60° Skew 0/180
N2 - 60° RL - Ax Scan

Robert Scott Getz II 4/22/2005
Operator Level Date
Analyst Level Date

Utility Review Level Date
ANIII Review Level Date



GE Energy, Nuclear

ULTRASONIC CALIBRATION DATA SHEET (Automated with Micro TomoScan)

Site Pilgrim Nuclear Power Unit 1

Project RF-015

Report Number APR-009

Calibration Sheet No. APC-075

Weld 2R-N2E-1

Procedure No. TP04-016 (GE-UT-209)

Version R1 (V17) DRR N/A

Instrument Zetec / uTomo 18121-08 2.2Q14 2.2Q14
 Manufacturer / Model System Serial No. Acquisition Software Analysis Software

Pulsar/Receiver R/D Tech EQTX 100 Pulsar/Receiver R/D Tech EQTX 101 Digitizer: R/D Tech EQTX 098
 Main Board: Manufacturer / Model Piggy Board: Manufacturer / Model Manufacturer / Model

Search Unit RTD 00-349 2(10x18)mm 1.0 MHz 60° / RL 0.50" 60" 0.50"
 Manufacturer Serial No. Element Size Freq. (MHz) Angle / Mode FD,FS/SA,RA Measured Incident to Wedge Front Angle

Cable RG-58/RG-58/RG-174 250' / 25' / 3' 2
 Type Length No. of Intermediate Connectors

Calibration Standard CAL-DPTH-063 SS 0.6" 0.6"
 Serial No. Material Nominal Thickness Measured Thickness

Thermometer 241878 75 °F Demin Water N/A
 Serial No. Temp (°F) Couplant Type Batch No.

Calibration			
Orientation	<u>Circ</u>	<u>Circ</u>	<u>Circ</u>
Type	<u>SDH</u>	<u>SDH</u>	<u>SDH</u>
Depth	<u>0.60 in.</u>	<u>0.60 in.</u>	<u>0.60 in.</u>
Amplitude / dB	<u>84.3%</u>	<u>-42.0 dB</u>	<u>-18.8 dB</u>
Sweep	<u>1.18 in.</u>	<u>1.18 in.</u>	<u>1.18 in.</u>
Gain (dB)	<u>32</u>	<u>Log</u>	<u>+25 Log</u>
Screen	<u>Half Path</u>	25 dB Booster	<u>Active</u>

Channel Name 60° RL 00-349 P3 / R3

General

Timebase Start 0.0 in. Range 5.5 in.
 Units Half Path

Digitizer

Synchro Pulse A Scan Sample Size 8 Bit
 Averaging 1 Acquisition Rate 301 Hz
 Digitizing Frequency 6.25 MHz Max Recurrence 2000 Hz

Field Simulator CS Rompage S/N CAL-RHOM-095

Reflector Near SDH N/A

Max Amplitude/dB -18.8 dB N/A

Sweep 0.78" N/A

Gain (dB) + Log N/A

Pulsar / Receiver

Configuration Conventional Pitch Catch

Pulsar P3 Receiver R3
 Voltage 300 V Scale Type LOG
 Width (Ns) 500 ns Rectification Unrelated
 Smoothing 1 MHz

Calibration Verification

	Time	Date	Block(s)	Operator
Initial	<u>0733</u>	<u>4/23/2005</u>	<u>CAL-DPTH-063</u>	<u>RJ</u>
Verified	<u>1025</u>	<u>4/23/2005</u>	<u>CAL-RHOM-095</u>	<u>RJ</u>
Verified	<u>1705</u>	<u>4/23/2005</u>	<u>CAL-RHOM-095</u>	<u>SG</u>
Verified				
Final	<u>0120</u>	<u>4/24/2005</u>	<u>CAL-RHOM-095</u>	<u>PK</u>

Probe

Wave Type Longitudinal Scan offset -5.20 in.
 Velocity 0.2372 in./sec. Index offset 0.00 in.
 Wedge Delay 9.597 usec. Angle 60°
 Skew 0/180

N2 - 60° RL - Circ Scan

Robert Scott Getz II 4/22/2005
 Operator Level Date
[Signature] TLL 4-25-05
 Analyst Level Date

[Signature] TLL 4/26/05
 Utility Review Level Date
[Signature] TLL 4/26/05
 ANIII Review Level Date

Page 149/240



GE ENERGY, NUCLEAR

EXAMINATION SUMMARY SHEET

Report No.:
APR-011

Site: **Pilgrim Nuclear Power Station** Component ID: **2R-N2G-1**
 Outage: **RF-015** **SAFE END TO NOZZLE**
 System **RPV** ASME Cat.: **B-F** ASME Item **B5.10** Aug Req **N/A**

Exams Performed	Data Sheet	Cal Sheet	Procedure	Calibration Block	Examination Personnel	Cert Level	Date
45° / S	N/A	APC-059	TP04-016 (GE-UT-209) R1 (V17)	PIL-78	Kyle Davidson	I-L	4/25/2005
45° / RL	N/A	APC-060	TP04-016 (GE-UT-209) R1 (V17)	PIL-78	Kyle Davidson	I-L	4/25/2005
45° / RL	N/A	APC-061	TP04-016 (GE-UT-209) R1 (V17)	PIL-78	Kyle Davidson	I-L	4/25/2005
60° / RL	N/A	APC-062	TP04-016 (GE-UT-209) R1 (V17)	CAL-DPTH-063	Kyle Davidson	I-L	4/25/2005
60° / RL	N/A	APC-063	TP04-016 (GE-UT-209) R1 (V17)	CAL-DPTH-063	Kyle Davidson	I-L	4/25/2005
N/A	APD-006	N/A	TP04-016 (GE-UT-209) R1 (V17)	N/A	Kyle Davidson	I-L	4/25/2005

Examination Results:

During the automated ultrasonic examination of the above referenced dissimilar metal weld, no indications associated with IGSCC were recorded with the "SMART 2000" system utilizing a 45° shear wave, 45° and 60° refracted longitudinal wave search units.

The 45° shear wave examinations were performed from both the upstream and downstream sides of the weld. Root geometry, inside surface geometry, beam redirect and non-relevant indications were recorded.

The 45° RL wave examinations were performed from both the upstream and downstream sides of the weld. Root geometry, acoustic interface, welding discontinuity, inside surface geometry and non-relevant indications were recorded.

The 60° RL wave examinations were performed from both the upstream and downstream sides of the weld. Acoustic interface, inside surface geometry, welding discontinuity, and non-relevant indications were recorded.

A welding discontinuity was detected and sized to IWB 3514-1. It was found to be acceptable. The indication had the following parameters:

Length: 8.83"-12.43"

Through wall: none

This indication was recorded but not reported in the previous automated data.

The outside surface weld crown did not meet procedure requirements from 0° to 4°, 23° to 28°, 31° to 34° and 38° to 42° circumferentially. 71.8% procedural coverage obtained. 75.3% code coverage obtained.

Previous automated electronic data and automated reports and drawings were reviewed prior to this summary.

Examination results were compared to data report 97-E-357 from 1997 outage with No Change

These examinations were performed under Work Order: 03118627 Change

This Summary and the following data sheets have been reviewed and accepted by the following personnel:

Prepared By: [Signature] Level: UT Date: 4-27-05
 Utility Review: [Signature] Date: 4-28-05
 ANII Review: [Signature] Date: 4/29/05

RWP: 0082
Dose: 1250 mr.

Page 1 of 14



GE ENERGY, NUCLEAR

Wall Thickness Profile Sheet

Site: Pilgrim Nuclear Power Station Unit: 1
Project: RF-016

Report No.:
APR-011

System: RPV

Component ID Number: 2R-N2G-1

Position	0°	90°	180°	270°
1	1.18"	N/A	N/A	N/A
2	1.17"	N/A	N/A	N/A
3	1.20"	N/A	N/A	N/A
4	1.14"	N/A	N/A	N/A
5	1.16"	N/A	N/A	N/A

Crown Height: FLUSH
Crown Width: 1.4"
Nominal Diameter: 12.0"
Weld Length: 42.25"

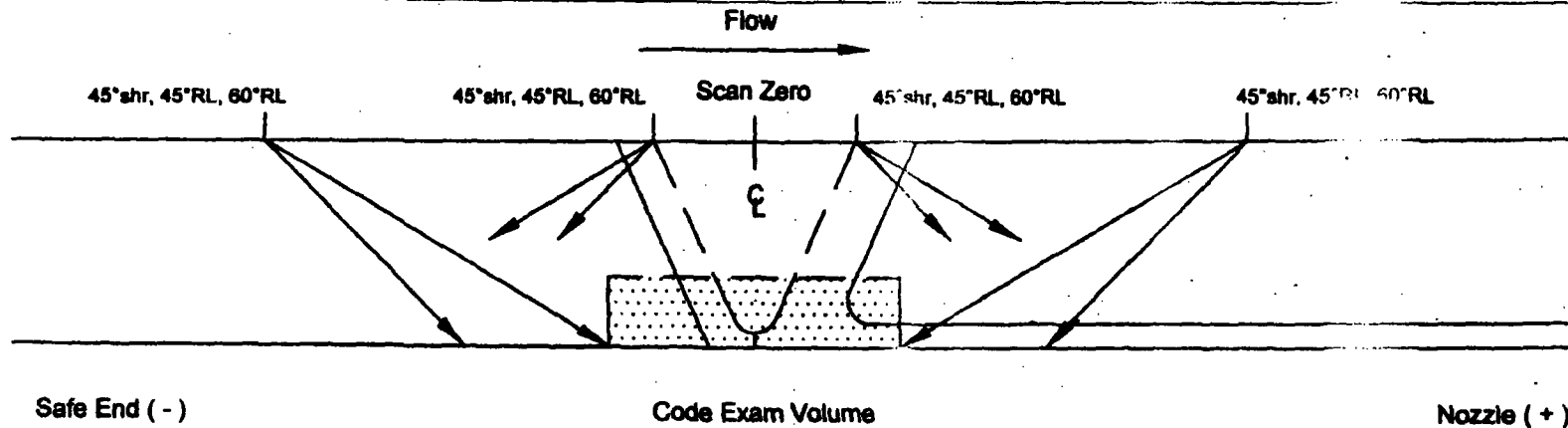
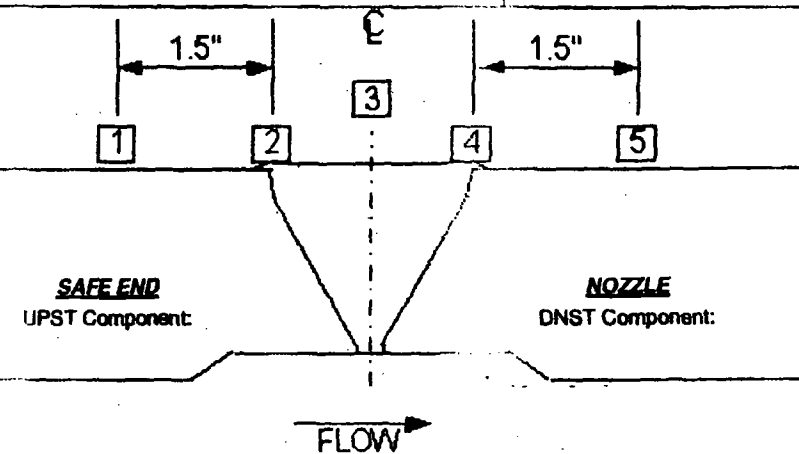

Weld preps obtained from drawings; 137C8066 and M1A73 sheet 2
Bottom of nozzle bore to Inc/CS interface = 4.0"
Bottom of SE taper to Inc/CS interface = 8.0"

Req 152/240

Charles Barrett II 4/25/2005
Initials: Examiner: Level: Date:

[Signature] III 4-27-05
GE Reviewed By: Level: Date:

[Signature] UT Lvl. III 4-28-05
Utility Review: Date:

[Signature] 4/29/05
ANII Review: Date:



GE ENERGY, NUCLEAR

Indication / Coverage Plot Sheet

Site: Pillarim Nuclear Power Station Unit: 1

Report Number.: APR-011

Project: RE-015

APR-011

System: RPV

Component ID Number: 2R-N2G-1

Configuration: SAFE END

NOZZLE

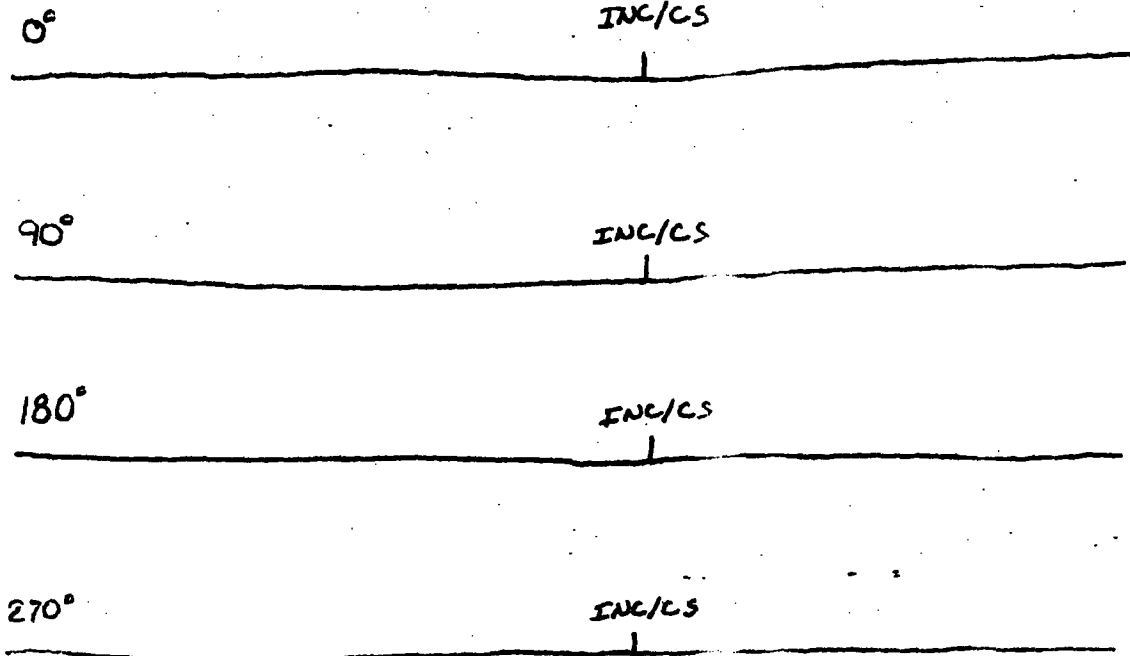

Page 153/240



Charles Barrett

II 4/25/2005

Initials: Examiner:

Level: Date:

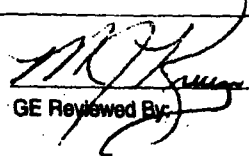

4-27-05

GE Reviewed By:

Level: Date:



4-28-05

Utility Reviewed By:

Date:

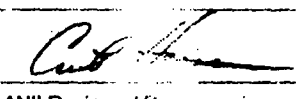

ANII Reviewed By:

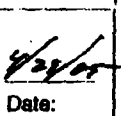

Date:



N2G Safe End to Nozzle

45°RL LKUP Welding Discontinuity

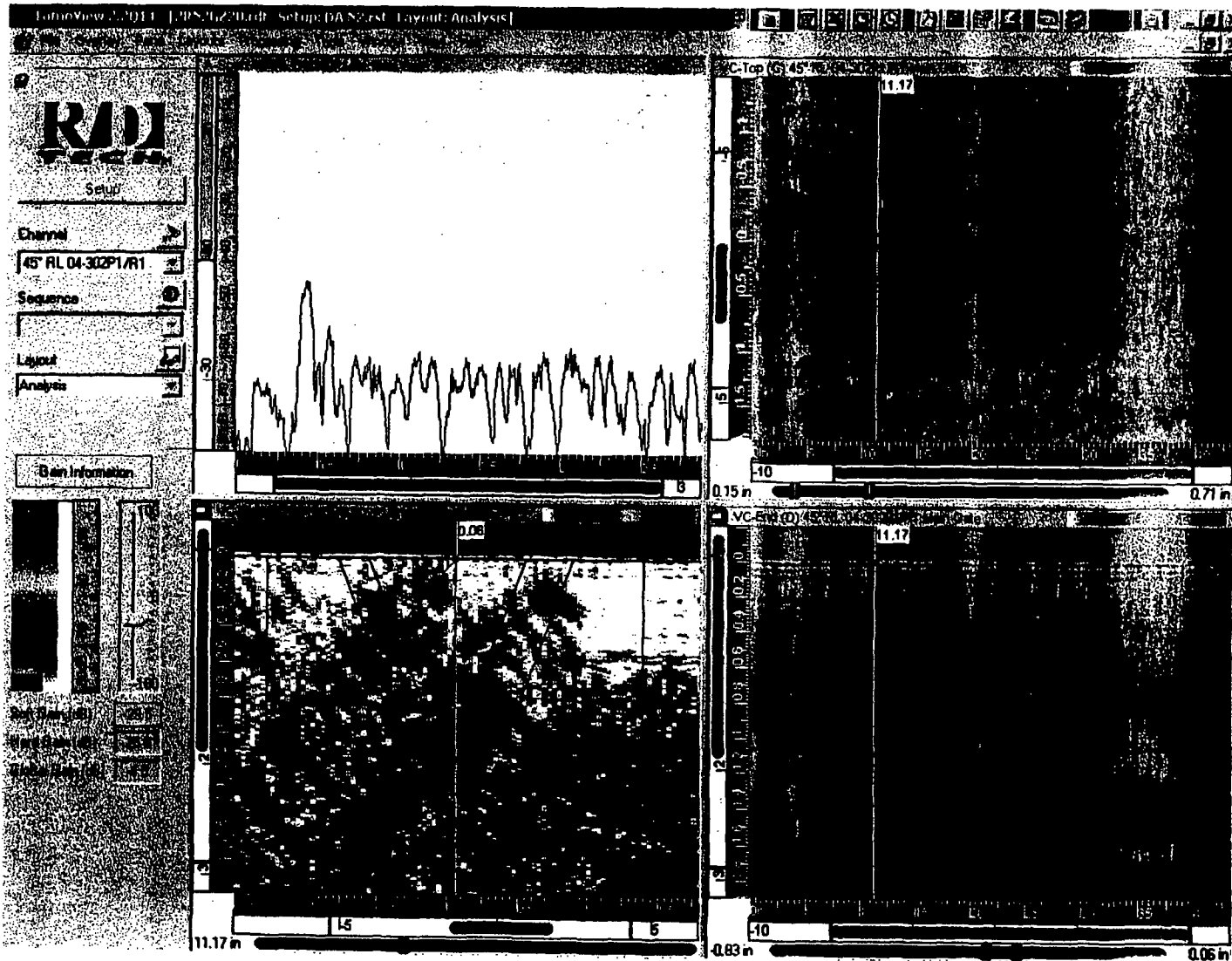

8092 154/240



N2G Safe End to Nozzle

60°RL LKUP Welding Discontinuity

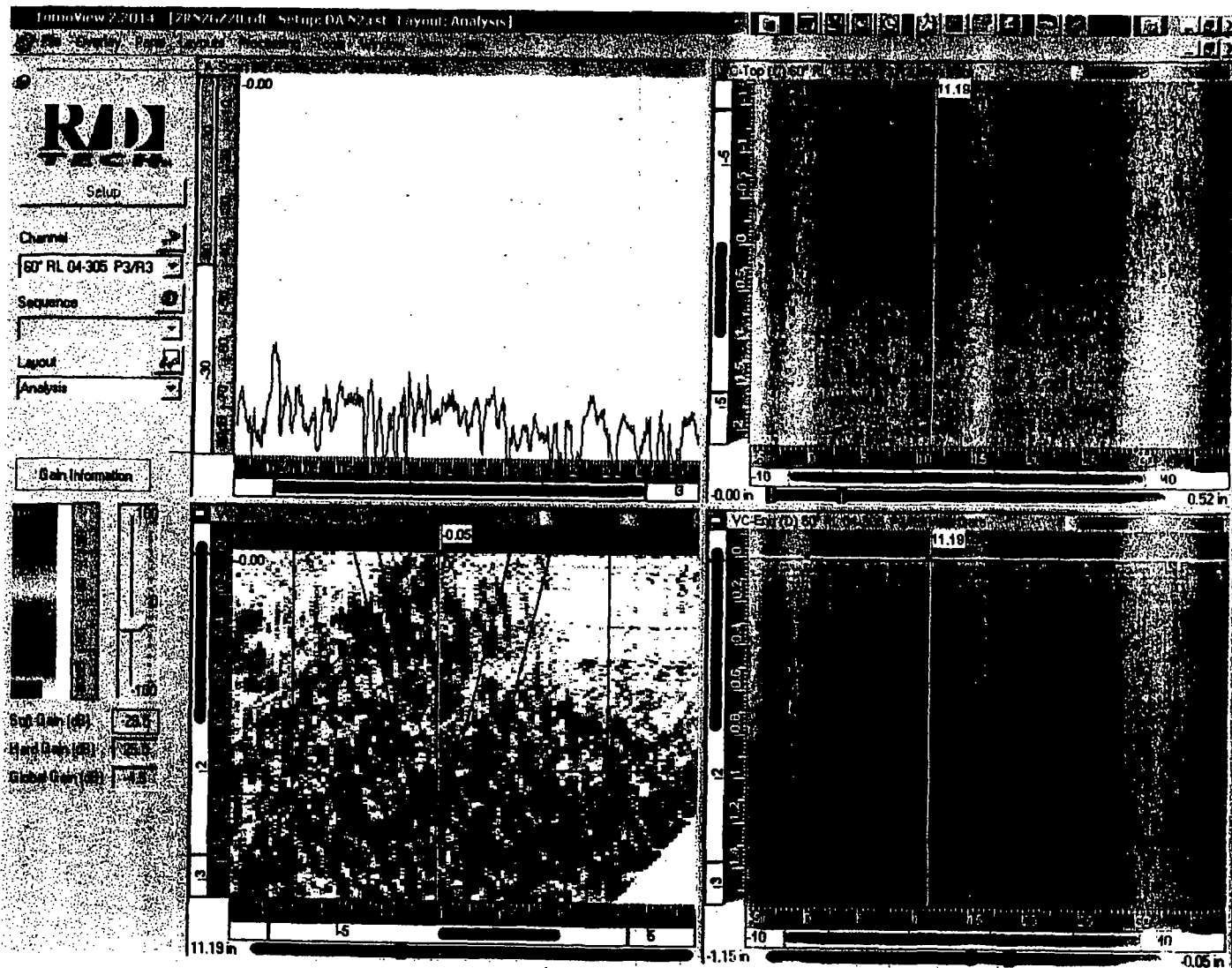

Page 155/240



N2G Safe End to Nozzle

45°RL LKUP Root Geometry

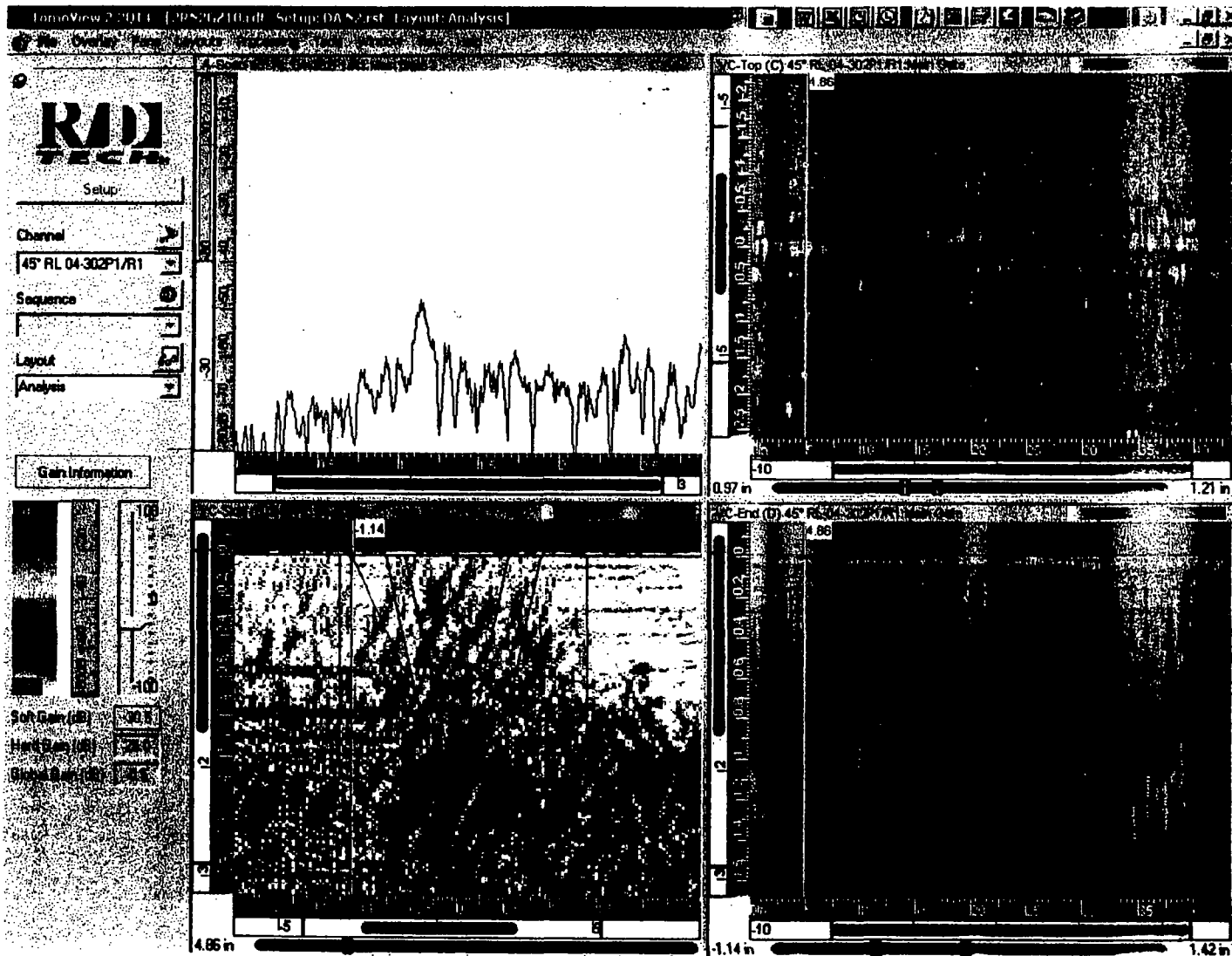

Page 156/240



GE Nuclear Energy

Ultrasonic Data / Scan Parameter Sheet
(Automated with Micro TomoScan)

Site: <u>Pillar Nuclear Power Station</u>	Procedure: <u>TP04-016 (GE-UT-209)</u>	System: <u>RPV</u>	Report No.: <u>APR-011</u>
Unit: <u>1</u>	Version / Revision: <u>R1(V17)</u>	Weld No.: <u>2R-N2G-1</u>	Data Sheet No.: <u>APD-006</u>
Project No.: <u>RF-015</u>	DRR: <u>N/A</u>	Configuration: <u>SAFE END TO NOZZLE</u>	Calibration Sheet No.

Scanner Information

Weld Reference, (GE-ADM-1005): Lo: TDC Wo: Weld Centerline Motor Steps: Cir: 2092 Tra: 2500
 Examination Surface: OD Exam Surface Temperature: 72 °F Thermometer S/N: 241878 Exam Start: 4/25/2005 4:20:00 AM
 Exam End: 4/25/2005 10:16:00 PM
 Nominal Pipe Size 12" Nominal Thickness: 1.07" Weld Width: 1.12" Weld Length: 42"
 Scanner: NOVA Track Diameter: 16" Arm Length: 16" Track Location: 7.5" UPST OF SE TAPER
 X Positive Scan Direction: DOWNSTREAM Y Positive Scan Direction: CW
 Resolution: ≤ 0.036" Index Ax / Circ: ≤ 0.18" ≤ 0.048" Axial Scan Speed: ≤ 1.94 in./Sec. Circ Scan Speed: ≤ 0.88 in./Sec.
 Scanner Zero Positions: CIR: TOP DEAD CENTER TRA: WELD CENTERLINE ROT Zero: LOOKING DOWNSTREAM

Scan Parameters and Results

Scan:	Skew:	File ID:	Disk:	X-Start:	X-Stop:	Y-Start:	Y-Stop:	Gain:	Results:	Comments:
Z10	0	2RN2GZ10	D-10	-4.1"	2.2"	0.0"	43.0"	Log	C,D,E,H	Uni-directional
Z20	180	2RN2GZ20	D-10	-2.4"	4.1"	0.0"	43.0"	Log	C,D,G,E	Uni-directional
Z30	0	2RN2GZ30	D-10	0.0"	43.0"	-2.7"	2.9"	Log	C	Uni-directional
Z40	180	2RN2GZ40	D-10	0.0"	43.0"	-0.8"	2.9"	Log	C	Uni-directional - Downstream side
Z42	180	2RN2GZ42	D-10	0.0"	43.0"	-2.7"	-1.1"	Log	C	Upstream side

EXAMINATION RESULTS LEGEND

A - NO RECORDABLE INDICATIONS B - NON-GEOMETRIC INDICATIONS C - NON-RELEVANT INDICATIONS D - ACOUSTIC INTERFACE
 E - INSIDE SURFACE F - OUTSIDE SURFACE G - WELD DISCONTINUITY H - ROOT GEOMETRY
 I - COUNTERBORE J - SHEAR COMPONENT K - BEAM RE-DIRECT

Comments:

High weld crown from a 'L' of 0"- 4", 23"- 28", 31"- 34" and 38"- 42". These areas do not meet the requirements of the procedure.

Page 157/240

Kyle Davidson	HL	4/25/2005	<i>[Signature]</i>	III	4-27-05	<i>[Signature]</i>	UT LVI.711	4-28-05	<i>[Signature]</i>	4/29/05
Examiner:	Level:	Date:	GE Review:	Level:	Date:	Utility Review:		Date:	ANII Review:	Date:



GE Energy, Nuclear

ULTRASONIC CALIBRATION DATA SHEET (Automated with Micro TomoScan)

Site Pilgrim Nuclear Power Unit 1 Project RF-015 Report Number APR-011 Calibration Sheet No. APC-059 Weld 2R-N2G-1

Procedure No. TP04-016 (GE-UT-209) Version R1 (V17) DRF N/A

Instrument Zetes / uTomo 18121-08 2.2Q14 2.2Q14 Manufacturer / Model System Serial No. Acquisition Software Analysis Software Pulsar/Receiver Main Board BVD Tech EQTX 100 BVD Tech EQTX 101 Digitizer: BVD Tech EQTX 099 Manufacturer / Model Search Unit RTD 03-341 EIK(24x17)mm 1.5 MHz 45°/S N/A 45° 0.52° Manufacturer Serial No. Element Size Freq. (MHz) Angle / Mode FD,FS/SA,RA Measured Incident to Cable RG-58/RG-58/RG-174 250' / 25' / 3' Length No. of Intermediate Connectors Calibration Standard PIL-78 SS 1.3" 1.3" Serial No. Material Nominal Thickness Measured Thickness Thermometer 241878 75 °F Couplant Demin Water N/A Serial No. Temp (°F) Type Batch No.

Calibration Orientation Circ Circ Type ID Notch ID Notch Depth 1.30 in. 1.30 in. Amplitude / dB 85.4% -9.4 dB Sweep 1.91 in. 1.91 in. Gain (dB) 1.0 Log Screen Half Path 25 dB Booster Inactive

Channel Name 03-341 45° Shear P2 General Timebase Start 0.0 in. Range 4.0 in. Units Half Path

Digitizer Synchro Pulse A Scan Sample Size 8 Bit Averaging 1 Acquisition Rate 301 Hz Digitizing Frequency 12.5 MHz Max Recurrence 2000 Hz

Pulsar / Receiver Configuration Conventional Pulse Echo Pulsar P2 Receiver N/A Voltage 300 V Scale Type LOG Width (Ns) 333 ns Rectification Unstated Smoothing 2 MHz

Field Simulator CS Rompas S/N CAL-RHOM-095 Reflector Far SDH Max Amplitude/dB -19.5 dB Sweep 1.01" Gain (dB) Log

Probe Wave Type Transverse Scan offset -2.60 in. Velocity 0.1240 in./sec. Index offset 0.00 in. Wedge Delay 11.778 usec. Angle 45° Skew 0/180

Calibration Verification table with columns: Time, Date, Block(s), Operator. Rows include Initial, Verified, and Final entries.

N2 - 45° Shear - Ax/Circ Scan Ax: Scan offset - 0.0" Index offset -2.6" Circ: Scan offset - 2.6" Index offset 0.0"

Operator Kyle Davidson I-L 4/25/2005 Analyst [Signature] JIL 4-27-05 Utility Review [Signature] JIL 4-28-05 ANIII Review [Signature] JIL 4-28-05 Page 9 of 14

Page 158/240



GE Energy, Nuclear

ULTRASONIC CALIBRATION DATA SHEET (Automated with Micro TomoScan)

Site Pilgrim Nuclear Power Unit 1 Project RF-015 Report Number APR-011 Calibration Sheet No. APC-060 Weld 2R-N2G-1

Procedure No. TP04-016 (GE-UT-209) Version R1 (V17) DRR N/A

Instrument Zetec / uTomo 18181-09 2.2Q14 2.2Q14 Manufacturer / Model System Serial No. Acquisition Software Analysis Software Pulsar/Receiver R/D Tech EQTX 100 R/D Tech EQTX 101 Digitizer: R/D Tech EQTX 098 Main Board: Manufacturer / Model Piggy Board: Manufacturer / Model Search Unit: RTD 04-302 2(10x18) mm 2.0 MHz 45° / RL 1.00" 45° 0.55" Manufacturer Serial No. Element Size Freq. (MHz) Angle / Mode FD_FS/SA,RA Measured Angle Incident to Wedge Front Cable RG-58/RG-58/RG-174 250' / 25' / 3' 2 No. of Intermediate Connectors Calibration Standard P1L-78 SS/INC 1.2" 1.2" Serial No. Material Nominal Thickness Measured Thickness Thermometer 241878 75 °F Couplant Demin Water N/A Serial No. Temp (°F) Type Batch No.

Table with 3 columns for Calibration. Headers: Orientation, Type, Depth, Amplitude / dB, Sweep, Gain (dB), Screen. Values: Circ, ID Notch, 1.30 in., 82.4%, 1.85 in., 23.0, Half Path.

Channel Name 45° RL 04-302 P1/R1 General Timebase Start 0.0 in. Range 4.0 in. Units Half Path

Digitizer Synchro Pulse A Scan Sample Size 8 Bit Averaging 1 Acquisition Rate 301 Hz Digitizing Frequency 12.5 MHz Max Recurrence 2000 Hz

Pulsar / Receiver Configuration Conventional Pitch Catch Pulsar P1 Receiver R1 Voltage 300 V Scale Type LOG Width (Ns) 250 ns Rectification Unsigned Smoothing 2 MHz

Field Simulator CS Rompas S/N CAL-RHOM-095 Reflector Far SDH Max Amplitude/dB -5.3 dB Sweep 1.04" Gain (dB) Log

Probe Wave Type Longitudinal Scan offset 0.00 in. Velocity 0.2272 in./sec. Index offset 0.00 in. Wedge Delay 9.675 usec. Angle 45° Skew 0/180

Table for Calibration Verification with columns: Time, Date, Block(s), Operator. Rows: Initial (0900, 4/11/2005, P1L 78, RJ), Verified (1840, 4/25/2005, CAL-RHOM-095, KD), Verified, Verified, Final (2216, 4/25/2005, CAL-RHOM-095, KD)

N2 - 45° RL - Ax Scan

Kyle Davidson I-L 4/25/2005 Operator Level Date Analyst Level Date 4/27/05

Utility Review Level Date 4/28/05 ANIII Review Level Date 4/29/05

Page 159/240



GE Energy, Nuclear

ULTRASONIC CALIBRATION DATA SHEET (Automated with Micro TomoScan)

Site Pilgrim Nuclear Power Unit 1 Weld 2R-N2G-1

Project RF-015

Report Number APR-011 Calibration Sheet No. APC-061

Procedure No. TP04-016 (GE-U7-209)

Version R1 (V17) DRF N/A

Instrument Zetec / uTomo 18121-09 2.2Q14 2.2Q14
Pulser/Receiver R/D Tech EQTX 100 R/D Tech EQTX 101 R/D Tech EQTX 098
Search Unit RTD 04-310 2(10x18) mm 1.0 MHz 45°/RL 0.84" 45° 0.55"
Cable RG-58/RG-58/RG-174 250' / 25' / 3' 2
Calibration Standard PIL-78 SS/1NG 1.3" 1.3"
Thermometer 241878 75 °F Demin Water N/A

Table with 4 columns: Orientation, Type, Depth, Amplitude / dB, Sweep, Gain (dB), Screen. Values include Circ, ID Notch, 1.30 in., 83.9%, 1.85 in., 37, Half Path.

Channel Name 45° RL 04-310 P1/R1
General
Timebase Start 0.0 in. Range 4.0 in.
Units Half Path

Digitizer
Synchro Pulse [X] A Scan Sample Size 8 Bit
Averaging 1 Acquisition Rate 301 Hz
Digitizing Frequency 6.25 MHz Max Recurrence 2000 Hz

Pulser / Receiver
Configuration Conventional Pitch Catch
Pulser P1 Receiver R1
Voltage 300 V Scale Type LOG
Width (Ns) 500 ns Rectification Unsigned
Smoothing 1 MHz

Probe
Wave Type Longitudinal Scan offset 0.00 in.
Velocity 0.2272 in./sec. Index offset 0.00 in.
Wedge Delay 11.170 usec. Angle 45°
Skew 0/180

Field Simulator CS Rompage S/N CAL-RHOM-095
Reflector Far SDH
Max Amplitude/dB -17.3 dB
Sweep 1.0°
Gain (dB) + Log

Table: Calibration Verification. Columns: Time, Date, Block(s), Operator. Rows: Initial, Verified, Verified, Verified, Final.

N2 - 45° RL - Circ Scan

Kyle Davidson I-L 4/25/2005
Operator Level Date
Analyst III 4-27-05 Level Date

Utility Review III 4-28-05 Level Date
ANIII Review Date

Page 160/240



GE Energy, Nuclear

ULTRASONIC CALIBRATION DATA SHEET (Automated with Micro TomoScan)

Site Pilgrim Nuclear Power Unit 1

Project RF-015

Report Number APR-011

Calibration Sheet No. APC-062

Weld 2R-N2G-1

Procedure No. TP04-016 (GE-UT-209)

Version: R1 (V17) DRR

N/A

Instrument Zetec / uTomo
Manufacturer / Model

18121-02

System Serial No.

2.2Q14

Acquisition Software

2.2Q14

Analysis Software

Pulsar/Receiver R/D Tech EQTX 100
Main Board: Manufacturer / Model

Pulsar/Receiver R/D Tech EQTX 101
Piggy Board: Manufacturer / Model

Digitizer: R/D Tech EQTX 088
Manufacturer / Model

Search Unit RTD 04-305
Manufacturer Serial No.

2(10x10)mm
Element Size

2.0 MHz 60°/RL
Freq. (MHz) Angle / Mode

0.77"
FD,FS/SA,RA

61° 0.52"
Measured Incident to
Angle Wedge Front

Cable RG-58/RG-58/RG-174
Type

250' / 25' / 3'
Length

2
No. of Intermediate Connectors

Calibration Standard CAL-DPTH-063
Serial No.

SS

Material

0.8"

Nominal Thickness

0.8"

Measured Thickness

Thermometer 241878
Serial No.

73 °F

Temp (°F)

Couplant

Demin Water

Type

N/A

Batch No.

Calibration

Orientation	<u>Circ</u>	<u>Circ</u>	<u>Circ</u>
Type	<u>SDH</u>	<u>SDH</u>	<u>SDH</u>
Depth	<u>0.80 in.</u>	<u>0.80 in.</u>	<u>0.80 in.</u>
Amplitude / dB	<u>81.5%</u>	<u>-33.9 dB</u>	<u>-9.4 dB</u>
Sweep	<u>1.65 in.</u>	<u>1.65 in.</u>	<u>1.65 in.</u>
Gain (dB)	<u>24</u>	<u>Log</u>	<u>+25 Log</u>
Screen	<u>Half Path</u>	25 dB Booster	<u>Active</u>

Channel Name 60° RL 04-305 P3 / R3

General

Timebase Start 0.0 in. Range 5.5 in.
Units Half Path

Digitizer

Synchro. Pulse A Scan Sample Size 8 Bit
Averaging 1 Acquisition Rate 301 Hz
Digitizing Frequency 12.5 MHz Max Recurrence 2000 Hz

Pulsar / Receiver

Configuration Conventional Pitch Catch
Pulsar P3 Receiver R3
Voltage 300 V Scale Type LOG
Width (Ns) 250 ns Rectification Unsigned
Smoothing 2 MHz

Probe

Wave Type Longitudinal Scan offset 0.00 in.
Velocity 0.2272 in./sec. Index offset -5.20 in.
Wedge Delay 10.637 usec. Angle 60°
Skew 0/180

N2 - 60° RL - Ax Scan

Field Simulator CS Rompage S/N CAL-RHOM-095

Reflector Far SDH

Max Amplitude/dB -7.2 dB

Sweep 1.55"

Gain (dB) + Log

Calibration Verification

	Time	Date	Block(s)	Operator
Initial	<u>0820</u>	<u>4/11/2005</u>	<u>CAL-DPTH-063</u>	<u>RJ</u>
Verified	<u>1844</u>	<u>4/25/2005</u>	<u>CAL-RHOM-095</u>	<u>KD</u>
Verified				
Verified				
Final	<u>2212</u>	<u>4/25/2005</u>	<u>CAL-RHOM-095</u>	<u>KD</u>

Kyle Davidson I-L 4/25/2005

Operator Level Date

[Signature] III 4-27-05

Analyst Level Date

[Signature] UT III 4-28-05

Utility Review Level Date

[Signature] 4/29/05

ANIII Review Level Date



GE Energy, Nuclear

ULTRASONIC CALIBRATION DATA SHEET (Automated with Micro TomoScan)

Site Pilgrim Nuclear Power Unit 1 Project RF-015 Report Number APR-011 Calibration Sheet No. APC-063 Weld 2R-N2G-1

Procedure No. TP04-016 (GE-UT-209) Version: R1 (V17) DRF: N/A

Instrument Zetec / uTomo 18121-02 2.2Q14 2.2Q14 Manufacturer / Model System Serial No. Acquisition Software Analysis Software Pulsar/Receiver Main Board R/D Tech EQTX 100 R/D Tech EQTX 101 Digitizer: R/D Tech EQTX 099 Manufacturer / Model Pulsar/Receiver Piggy Board: Manufacturer / Model Search Unit RTD 00-349 2(10x18)mm 1.0 MHz 60° / RL 0.58" 60° 0.50" Manufacturer Serial No. Element Size Freq. (MHz) Angle / Mode FD,FS/SA,RA Measured Angle Incident to Wedge Front Cable RG-58/RG-58/RG-174 250' / 25' / 3' Length No. of Intermediate Connectors 2 Calibration Standard CAL-DPTH-063 SS 0.6" 0.6" Serial No. Material Nominal Thickness Measured Thickness Thermometer 241878 75 °F Couplant Demin Water N/A Serial No. Temp. / °F Type Batch No.

Calibration Orientation Circ Circ Circ Type SDH SDH SDH Depth 0.60 in. 0.60 in. 0.60 in. Amplitude / dB 84.3% -42.0 dB -18.8 dB Sweep 1.18 in. 1.18 in. 1.18 in. Gain (dB) 32 Log +25 Log Screen Half Path 25 dB Booster Active Field Simulator CS Romoss S/N CAL-RHOM-095 Reflector Near SDH N/A Max Amplitude/dB -18.8 dB N/A Sweep 0.78" N/A Gain (dB) + Log N/A

Channel Name 60° RL 00-349 P3 / R3 General Timebase Start 0.0 in. Range 5.5 in. Units Half Path Digitizer Synchro Pulse A Scan Sample Size 8 B/s Averaging 1 Acquisition Rate 301 Hz Digitizing Frequency 6.25 Mhz Max Recurrence 2000 Hz Pulsar / Receiver Configuration Conventional Pitch Catch Pulsar P3 Receiver R3 Voltage 300 V Scale Type LOG Width (Ns) 500 ns Rectification Unsigned Smoothing 1 MHz Probe Wave Type Longitudinal Scan offset -5.20 in. Velocity 0.2272 in./sec. Index offset 0.00 in. Wedge Delay 10.240 usec. Angle 60° Skew 0/180

Calibration Verification table with columns: Time, Date, Block(s), Operator. Rows: Initial (0733, 4/23/2005, CAL-DPTH-063, RJ), Verified (0300, 4/25/2005, CAL-RHOM-095, KD), Verified (0738, 4/25/2005, CAL-RHOM-095, SG), Verified, Final (1844, 4/25/2005, CAL-RHOM-095, KD)

Kyle Davidson I-L 4/25/2005 Operator Level Date Utility Review Analyst Level Date ANIII Review Page 13 of 14

Page 162/240



GE Energy Nuclear

Micro-Tomo (Smart 2000) - Auto Piping Weld Examination Checklist

**Pilgrim Unit 1, 2005
2R-N2G**

2RN2GZ10 LKDN	Load appropriate setup	Offsets entered into TV correctly	Transducers Skewed IAW Procedure	Files named IAW Scanplan	360° contact achieved	360° Circ coverage achieved	Full Volume Ax Coverage Achieved	Scan saved to computer HD Verified readable	Data transferred to DA Verified received by DA	Data Reviewed	Analysis Complete	Package Complete	NOTES:
45° Shear	<input checked="" type="checkbox"/>	<input checked="" type="checkbox"/>	<input checked="" type="checkbox"/>	<input checked="" type="checkbox"/>	<input checked="" type="checkbox"/>	<input type="checkbox"/>	<input checked="" type="checkbox"/>	KD	MW	MJK	MJK	MJK	
45° RL	<input checked="" type="checkbox"/>	<input checked="" type="checkbox"/>	<input checked="" type="checkbox"/>	<input checked="" type="checkbox"/>	<input type="checkbox"/>	<input checked="" type="checkbox"/>	MJK			MJK	MJK		
60° RL	<input checked="" type="checkbox"/>	<input checked="" type="checkbox"/>	<input checked="" type="checkbox"/>	<input checked="" type="checkbox"/>	<input type="checkbox"/>	<input checked="" type="checkbox"/>	MJK			MJK	MJK		
2RN2GZ20 LKUP	Load appropriate setup	Offsets entered into TV correctly	Transducers Skewed IAW Procedure	Files named IAW Scanplan	360° contact achieved	360° Circ coverage achieved	Full Volume Ax Coverage Achieved	Scan saved to computer HD Verified readable	Data transferred to DA Verified received by DA	Data Reviewed	Analysis Complete	Package Complete	NOTES:
45° Shear	<input checked="" type="checkbox"/>	<input checked="" type="checkbox"/>	<input checked="" type="checkbox"/>	<input checked="" type="checkbox"/>	<input checked="" type="checkbox"/>	<input type="checkbox"/>	<input checked="" type="checkbox"/>	KD	KD	MJK	MJK	MJK	
45° RL	<input checked="" type="checkbox"/>	<input checked="" type="checkbox"/>	<input checked="" type="checkbox"/>	<input checked="" type="checkbox"/>	<input type="checkbox"/>	<input checked="" type="checkbox"/>	MJK			MJK	MJK		
60° RL	<input checked="" type="checkbox"/>	<input checked="" type="checkbox"/>	<input checked="" type="checkbox"/>	<input checked="" type="checkbox"/>	<input type="checkbox"/>	<input checked="" type="checkbox"/>	MJK			MJK	MJK		
2RN2GZ30 LKCW	Load appropriate setup	Offsets entered into TV correctly	Transducers Skewed IAW Procedure	Files named IAW Scanplan	360° contact achieved	360° Circ coverage achieved	Full Volume Ax Coverage Achieved	Scan saved to computer HD Verified readable	Data transferred to DA Verified received by DA	Data Reviewed	Analysis Complete	Package Complete	NOTES:
45° Shear	<input checked="" type="checkbox"/>	<input checked="" type="checkbox"/>	<input checked="" type="checkbox"/>	<input checked="" type="checkbox"/>	<input checked="" type="checkbox"/>	<input checked="" type="checkbox"/>	<input type="checkbox"/>	SG	SG	MJK	MJK	MJK	
45° RL	<input checked="" type="checkbox"/>	<input checked="" type="checkbox"/>	<input checked="" type="checkbox"/>	<input checked="" type="checkbox"/>	<input checked="" type="checkbox"/>	<input checked="" type="checkbox"/>	<input type="checkbox"/>			MJK	MJK	MJK	
60° RL	<input checked="" type="checkbox"/>	<input checked="" type="checkbox"/>	<input checked="" type="checkbox"/>	<input checked="" type="checkbox"/>	<input checked="" type="checkbox"/>	<input checked="" type="checkbox"/>	<input type="checkbox"/>			MJK	MJK	MJK	
2RN2GZ40 LKCCW	Load appropriate setup	Offsets entered into TV correctly	Transducers Skewed IAW Procedure	Files named IAW Scanplan	360° contact achieved	360° Circ coverage achieved	Full Volume Ax Coverage Achieved	Scan saved to computer HD Verified readable	Data transferred to DA Verified received by DA	Data Reviewed	Analysis Complete	Package Complete	NOTES:
45° Shear	<input checked="" type="checkbox"/>	<input checked="" type="checkbox"/>	<input checked="" type="checkbox"/>	<input checked="" type="checkbox"/>	<input checked="" type="checkbox"/>	<input checked="" type="checkbox"/>	<input type="checkbox"/>	SG	SG	MJK	MJK	MJK	
45° RL	<input checked="" type="checkbox"/>	<input checked="" type="checkbox"/>	<input checked="" type="checkbox"/>	<input checked="" type="checkbox"/>	<input checked="" type="checkbox"/>	<input checked="" type="checkbox"/>	<input type="checkbox"/>			MJK	MJK	MJK	
60° RL	<input checked="" type="checkbox"/>	<input checked="" type="checkbox"/>	<input checked="" type="checkbox"/>	<input checked="" type="checkbox"/>	<input checked="" type="checkbox"/>	<input checked="" type="checkbox"/>	<input type="checkbox"/>			MJK	MJK	MJK	

Notes: Weld profile does not meet procedural requirements from 0"-4", 23"-28", 31"-34" and 38"-42"

Page 163/240

[Signature] UT L-1 III 4-28-05



GE ENERGY, NUCLEAR

EXAMINATION SUMMARY SHEET

Report No.: APR-012

Site: Pilgrim Nuclear Power Station Component ID: 2R-N2J-1
 Outage: RF-015 SAFE END TO NOZZLE
 System RPV ASME Cat.: B-F ASME Item B5.10 Aug Req N/A

Exams Performed	Data Sheet	Cal Sheet	Procedure	Calibration Block	Examination Personnel	Cert Level	Date
45° / RL	N/A	APC-066	TP04-016 (GE-UT-209) R1 (V17)	PIL-76	Kyle Davidson	I-L	4/25/2005
45° / RL	N/A	APC-067	TP04-016 (GE-UT-209) R1 (V17)	PIL-78	Richard Jasken	II	4/27/2005
60° / RL	N/A	APC-068	TP04-016 (GE-UT-209) R1 (V17)	CAL-DPTH-063	Kyle Davidson	I-L	4/25/2005
60° / RL	N/A	APC-069	TP04-016 (GE-UT-209) R1 (V17)	CAL-DPTH-063	Richard Jasken	II	4/27/2005
45° / S	N/A	APC-065	TP04-016 (GE-UT-209) R1 (V17)	PIL-78	Richard Jasken	II	4/27/2005
N/A	APD-008	N/A	TP04-016 (GE-UT-209) R1 (V17)	N/A	Richard Jasken	II	2/27/2005

Examination Results:

During the automated ultrasonic examination of the above referenced dissimilar metal weld, no indications associated with IGSCC or any reportable indications were recorded with the "SMART 2000" system utilizing a 45° shear wave and 45° & 60° refracted longitudinal wave search units.

The 45° shear wave examinations were performed from both the upstream and downstream sides of the weld. Root geometry, beam redirect and non-relevant indications were recorded.

The 45° RL wave examinations were performed from both the upstream and downstream sides of the weld. Root geometry, acoustic interface, inside surface geometry and non-relevant indications were recorded.

The 60° RL wave examinations were performed from both the upstream and downstream sides of the weld. Inside surface geometry and non-relevant indications were recorded.

The outside surface weld crown did not meet procedure requirements from 13° to 30° on the upstream side of weld centerline and from 0° to 42.0° on the downstream side of the weld centerline to a 'W' of 1.10".

65.7% procedural coverage was obtained.
75% code coverage was obtained.

Previous automated reports and drawings were reviewed prior to this summary.

Examination results were compared to data report 95-E-434 from 1995 outage with No Change

These examinations were performed under Work Order: 03118627 Change

This Summary and the following data sheets have been reviewed and accepted by the following personnel:

Prepared By: [Signature] Level: III Date: 4-28-05
 Utility Review: [Signature] Date: 4-29-05
 ANII Review: [Signature] Date: 4/29/05

RWP: 0082
Dose: 1500 mr.

Page 1 of 13

Page 164/240



GE ENERGY, NUCLEAR

Wall Thickness Profile Sheet

Site: Pilarin Nuclear Power Station Unit: 1

Report No.:

Project: RF-015

APR-012

System: RPV

Component ID Number: 2R-N2-L1

Position	0°	90°	180°	270°
1	1.11"	N/A	N/A	N/A
2	1.11"	N/A	N/A	N/A
3	1.13"	N/A	N/A <td N/A	
4	1.10"	N/A	N/A	N/A
5	1.14"	N/A	N/A	N/A

Crown Height: 0.1"
 Crown Width: 1.8"
 Nominal Diameter: 12.0"
 Weld Length: 42.0"

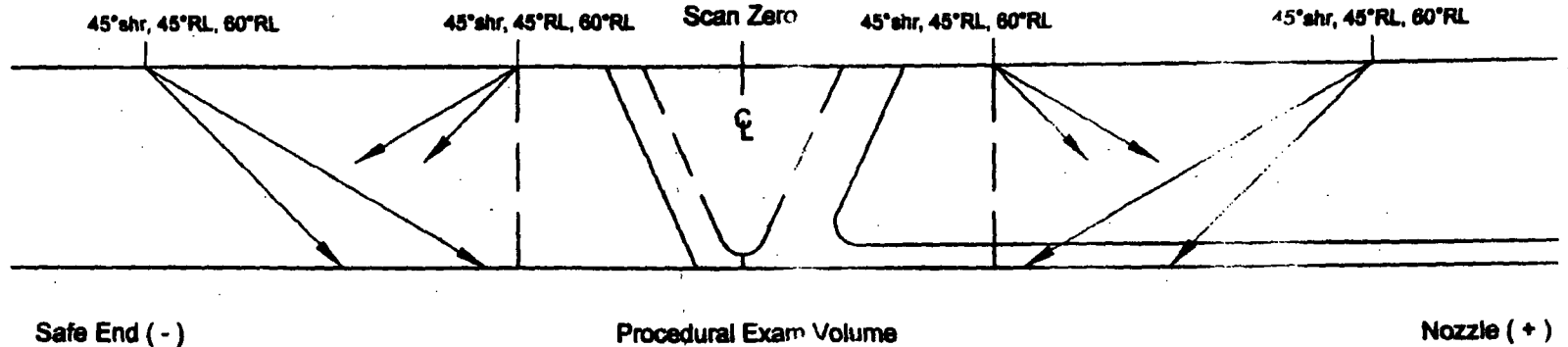
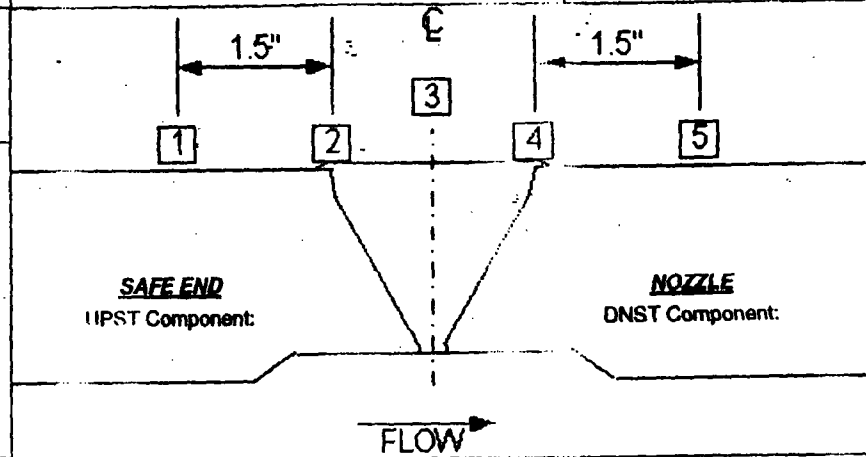

Weld preps obtained from drawings; 137C8066 and M1A73 sheet 2
 Bottom of nozzle bore to Inc/CS interface = 4.1"
 Bottom of SE taper to Inc/CS interface = 7.5"

Page 165/240

Michael Krueger III 4/27/2005
 Initials: Examiner: Level: Date:

[Signature] 4-29-05
 GE Reviewed By: Level: Date:

[Signature] UT LVI-III 4-29-05
 Utility Review: Date:

[Signature] 4/29/05
 ANII Review: Date:



GE ENERGY, NUCLEAR

Wall Thickness Profile Sheet

Site: Pilarim Nuclear Power Station Unit: 1

Report No.:

Project: RF-015

APR-012

System: RPV

Component ID Number: 2R-N2-L1

Position	0°	90°	180°	270°
1	1.11"	N/A	N/A	N/A
2	1.11"	N/A	N/A	N/A
3	1.13"	N/A	N/A	N/A
4	1.10"	N/A	N/A	N/A
5	1.14"	N/A	N/A	N/A

Crown Height: 0.1"

Crown Width: 1.8"

Nominal Diameter: 12.0"

Weld Length: 42.0"

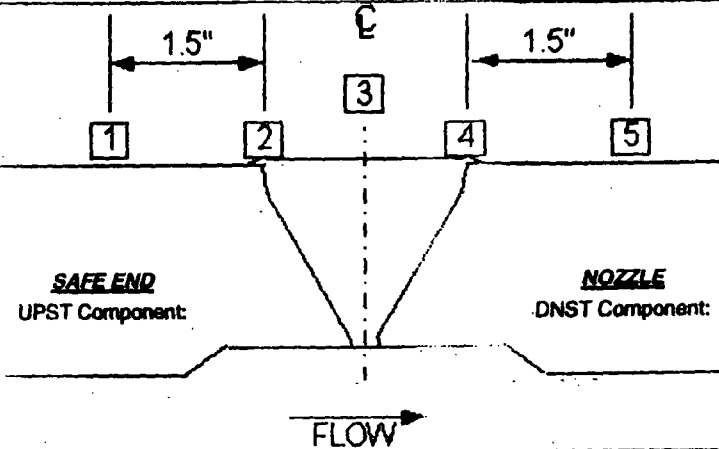

Flow →

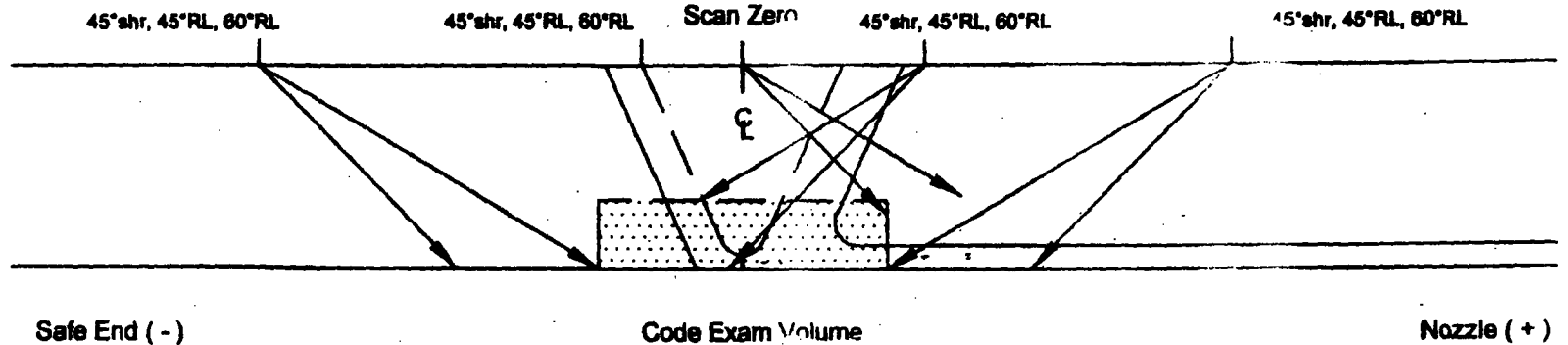

The scans above show the limited areas. The entire volume was scanned.
 Weld preps obtained from drawings; 137C8066 and M1A73 sheet 2
 Bottom of nozzle bore to Inc/CS interface = 4.1"
 Bottom of SE taper to Inc/CS interface = 7.5"

Page 166/240

Michael Krueger III 4/27/2005
 Initials: Examiner: Level: Date:

Michael Krueger III 4-29-05
 GE Reviewed By: Level: Date:

Michael Krueger AT LVL. III 4-29-05
 Utility Review: Date:

Chris 4/29/05
 ANII Review: Date:



GE ENERGY, NUCLEAR

Indication / Coverage Plot Sheet

Site: Pilgrim Nuclear Power Station Unit: 1

Report Number.:

Project: BE-015

APR-012

System: RPY

Component ID Number: 2B-N2L-1

Configuration: SAFE END

NOZZLE

0° TDC

ENC/CS

90°

ENC/CS

180°

ENC/CS

270°

ENC/CS

Boor 167/240

MK Michael Krueger III 4/27/2005
Initials: Examiner: Level: Date:

[Signature] III 4-29-05
GE Reviewed By: Level: Date:

[Signature] III 4-29-05
Utility Reviewed By: Level: Date:

[Signature] 4/29/05
ANII Reviewed By: Level: Date:



N2J Safe End to Nozzle

45°RL LKDN Root Geometry

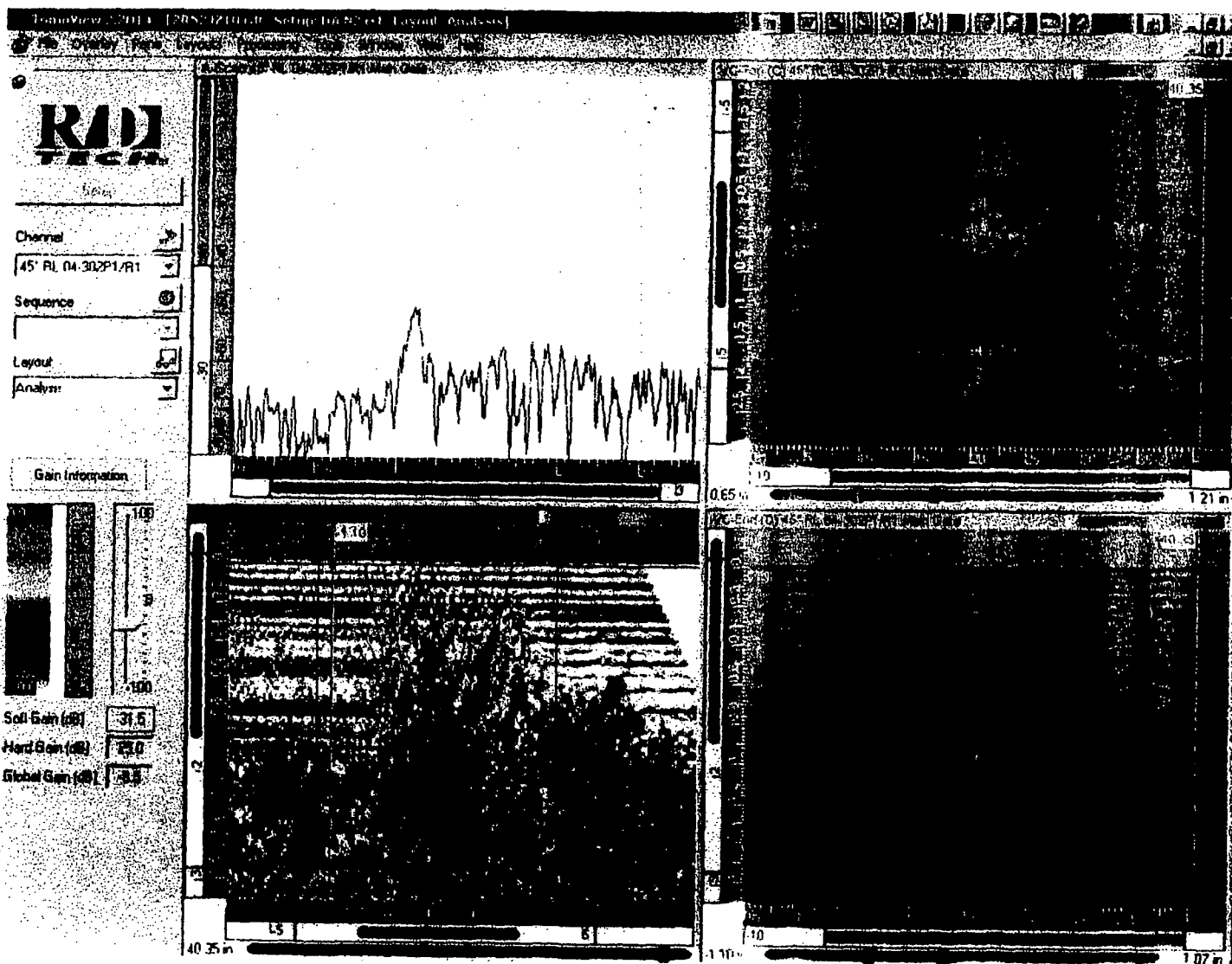

Page 168/240



N2J Safe End to Nozzle

45°RL LKDN Acoustic Interface

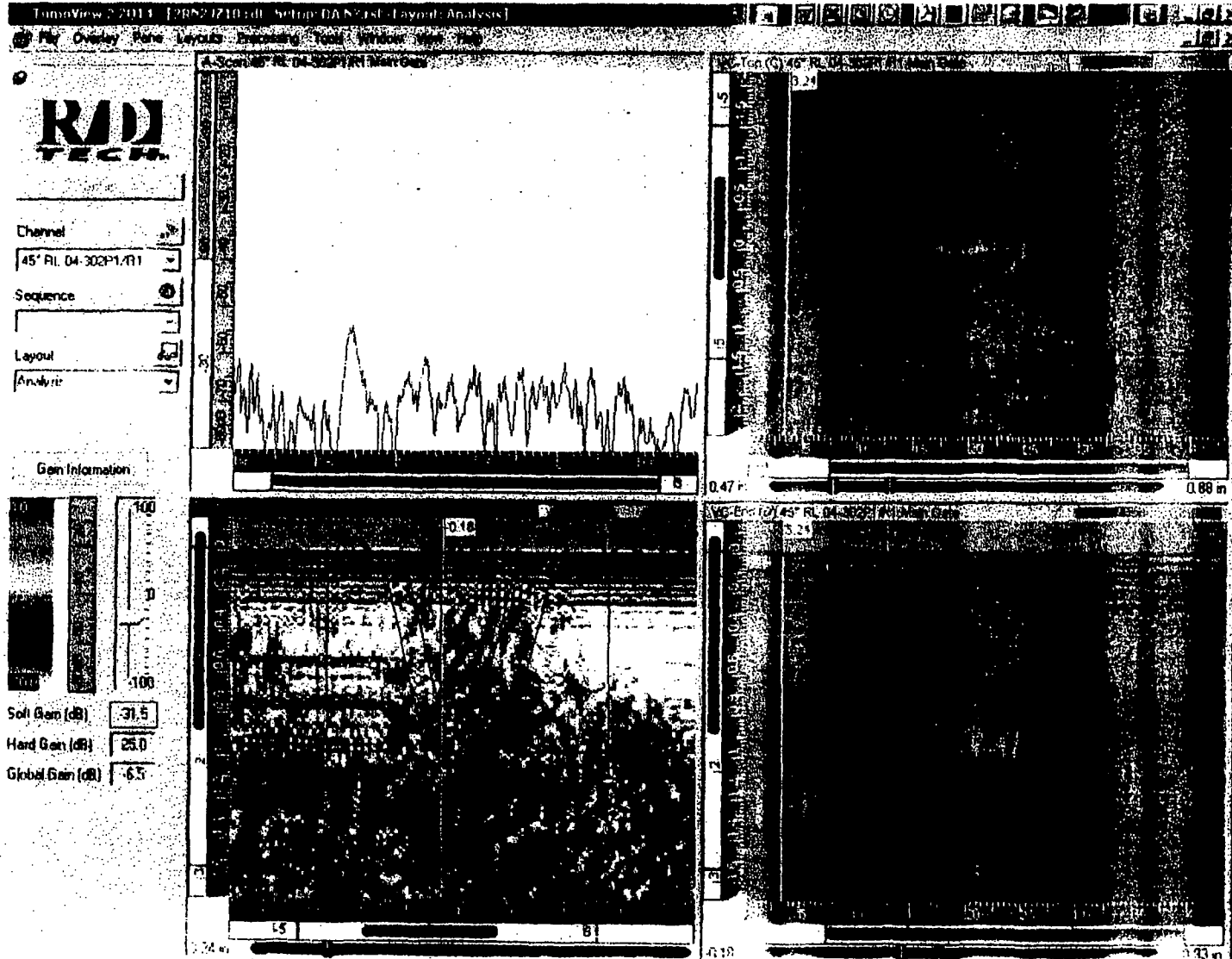

Log# 169/240

Handwritten signature/initials



GE Nuclear Energy

Ultrasonic Data / Scan Parameter Sheet
(Automated with Micro TomoScan)

Site: <u>Pilgrim Nuclear Power Station</u>	Procedure: <u>TP04-016 (GE-UT-209)</u>	System: <u>RPV</u>	Report No.: <u>APR-012</u>
Unit: <u>1</u>	Version / Revision: <u>R1 (V17)</u>	Weld No.: <u>2R-N2-J-1</u>	Data Sheet No.: <u>APD-008</u>
Project No.: <u>RF-015</u>	DRR: <u>N/A</u>	Configuration: <u>SAFE END TO NOZZLE</u>	Calibration Sheet No.

Scanner Information

Weld Reference, (GE-ADM-1005): Lo: TDC Wo: Weld Centerline Motor Steps: Cir: 2076 Tra: 2500

Examination Surface: OD Exam Surface Temperature: 81 °F Thermometer S/N: 241878 Exam Start: 4/25/2005 11:30:00 PM

Exam End: 4/27/2005 11:07:00 AM

Nominal Pipe Size 12" Nominal Thickness: 1.10" Weld Width: 1.8" Weld Length: 42"

Scanner: NOVA Track Diameter: 18" Arm Length: 18" Track Location: 15.5" UPST FROM CS/INC INTERFACE

X Positive Scan Direction: DOWNSTREAM Y Positive Scan Direction: CW

Resolution: ≤ 0.036" Index Ax / Circ: ≤ 0.18" ≤ 0.049" Axial Scan Speed: ≤ 2.0 in./Sec. Circ Scan Speed: ≤ 1.0 in./Sec.

Scanner Zero Positions: CIR: TOP DEAD CENTER TRA: WELD CENTERLINE ROT Zero: LOOKING DOWNSTREAM

Scan Parameters and Results

Scan:	Skew:	File ID:	Disk:	X-Start:	X-Stop:	Y-Start:	Y-Stop:	Gain:	Results:	Comments:
Z10	0	2RN2JZ10	D-13	-4.1"	2.4"	0.0"	43.0"	Loa	G.D.H.E	Uni-directional
Z20	180	2RN2JZ20	D-13	-2.4"	4.2"	0.0"	43.0"	Loa	G.E	Uni-directional
Z30	0	2RN2JZ30	D-13	0.0"	43.0"	-2.7"	2.9"	Loa	G.E	Uni-directional
Z40	180	2RN2JZ40	D-13	0.0"	43.0"	-2.7"	2.9"	Loa	G.E	Uni-directional

EXAMINATION RESULTS LEGEND

A - NO RECORDABLE INDICATIONS	B - NON-GEOMETRIC INDICATIONS	C - NON-RELEVANT INDICATIONS	D - ACOUSTIC INTERFACE
E - INSIDE SURFACE	F - OUTSIDE SURFACE	G - WELD DISCONTINUITY	H - ROOT GEOMETRY
I - COUNTERBORE	J - SHEAR COMPONENT	K - BEAM RE-DIRECT	

Comments:

* Inside surface geometry outside the exam volume.
 LKDN limited from a 'L' of 13" to 30" on the upstream side of the weld centerline due to the OD contour.
 LKUP limited from a 'L' of 0" to 42.0" on the downstream side of the weld centerline due to the OD contour.

Page 170/240

Richard Jasken	II	4/27/2005	<i>[Signature]</i>	4/28-05	<i>[Signature]</i>	4/29-05	<i>[Signature]</i>	4/29-05
Examiner:	Level:	Date:	GE Review:	Level:	Date:	Utility Review:	Date:	ANII Review: <i>[Signature]</i> Date: <i>[Signature]</i>



GE Energy, Nuclear

ULTRASONIC CALIBRATION DATA SHEET (Automated with Micro TomoScan)

Site Pilgrim Nuclear Power Unit 1 Project RF-015 Report Number APR-012 Calibration Sheet No. APC-065 Weld 2R-N2J-1

Procedure No. TP04-016 (GE-UT-209) Version R1 (V17) DRR N/A

Instrument Zetec / uTomo 18121-09 2.2Q14 2.2Q14 Manufacturer / Model System Serial No. Acquisition Software Analysis Software. Pulsar/Receiver R/D Tech EQTX 100 R/D Tech EQTX 101 Digitizer: R/D Tech EQTX 088 Main Board: Manufacturer / Model Piggy Board: Manufacturer / Model Search Unit RTD 03-341 EIK(24x17) mm 1.5 MHz 45° / S N/A 45° 0.52° Manufacturer Serial No. Element Size Freq. (MHz) Angle / Mode FD,FS/SA,RA Measured Incident to Cable RG-58/RG-58/RG-174 250' / 25' / 3' Length 2 No. of Intermediate Connectors Calibration Standard P1L-78 SS 1.3" 1.3" Serial No. Material Nominal Thickness Measured Thickness Thermometer 241878 75 °F Couplant Demin Water N/A Serial No. Temp (°F) Type Batch No.

Calibration Orientation Circ Circ Type ID Notch ID Notch Depth 1.30 in. 1.30 in. Amplitude / dB 85.4% -9.4 dB Sweep 1.91 in. 1.91 in. Gain (dB) 1.0 Log Screen Half Path 25 dB Booster Inactive Field Simulator CS Rompas S/N CAL-RHOM-095 Reflector Far SDH Max Amplitude/dB -19.5 dB Sweep 1.01" Gain (dB) Log

Channel Name 03-341 45° Shear P2 General Timebase Start 0.0 in. Range 4.0 in. Units Half Path Digitizer Synchro Pulse A Scan Sample Size 8 Bit Averaging 1 Acquisition Rate 301 Hz Digitizing Frequency 12.5 MHz Max Recurrence 2000 Hz Pulsar / Receiver Configuration Conventional Pulse Echo Pulsar P2 Receiver N/A Voltage 300 V Scale Type LOG Width (Ns) 333 ns Rectification Unsigned Smoothing 2 MHz Probe Wave Type Transverse Scan offset Velocity 0.1240 in./sec. Index offset Wedge Delay 11.778 usec. Angle 45° Skew 0/180

Calibration Verification table with columns: Time, Date, Block(s), Operator. Rows: Initial (0847, 4/11/2005, P1L 78, RJ), Verified (2214, 4/25/2005, CAL-RHOM-095, KD), Verified (0142, 4/26/2005, CAL-RHOM-095, KD), Verified, Final (1106, 4/27/2005, CAL-RHOM-095, RJ)

N2 - 45° Shear - Ax/Circ Scan Ax scan offset 0.0" Index Offset -2.6" Circ scan offset -2.60" Index Offset -2.7"

Richard Jasken II 4/27/2005 Operator Level Date Analyst Level Date Utility Review Level Date ANIII Review Level Date Page 8 of 13

Page 171/240



GE Energy, Nuclear

ULTRASONIC CALIBRATION DATA SHEET (Automated with Micro TomoScan)

Site Pilgrim Nuclear Power Unit 1

Project RF-015

Report Number APR-012

Calibration Sheet No. APC-066

Weld 2R-N2-J-1

Procedure No. TP04-016 (GE-UT-209)

Version R1 (V17) DRF N/A

Instrument	<u>Zetec / u Tomo</u> Manufacturer / Model	<u>18121-08</u> System Serial No.	<u>2.2Q14</u> Acquisition Software	<u>2.2Q14</u> Analysis Software
Pulsar/Receiver Main Board:	<u>R/D Tech EQTX 100</u> Manufacturer / Model	Pulsar/Receiver Piggy Board: <u>R/D Tech EQTX 101</u> Manufacturer / Model.	Digitizer:	<u>R/D Tech EQTX 098</u> Manufacturer / Model
Search Unit	<u>RTD</u> Manufacturer	<u>04-302</u> Serial No.	<u>2(10x18)mm</u> Element Size	<u>2.0 MHz</u> Freq. (MHz)
			<u>45° / RL</u> Angle / Mode	<u>1.00"</u> FD,FS/SA,RA
Cable	<u>RG-58/RG-58/RG-174</u> Type	<u>250' / 25' / 3'</u> Length	<u>2</u> No. of Intermediate Connectors	<u>45°</u> Measured Angle
				<u>0.55"</u> Incident to Wedge Front
Calibration Standard	<u>PIL-78</u> Serial No.	<u>SS/NC</u> Material	<u>1.3"</u> Nominal Thickness	<u>1.3"</u> Measured Thickness
Thermometer	<u>241978</u> Serial No.	<u>75 °F</u> Temp (°F)	<u>Demin Water</u> Type	<u>N/A</u> Batch No.

Calibration			
Orientation	<u>Circ</u>	<u>Circ</u>	<u>Circ</u>
Type	<u>ID Notch</u>	<u>ID Notch</u>	<u>ID Notch</u>
Depth	<u>1.30 in.</u>	<u>1.30 in.</u>	<u>1.30 in.</u>
Amplitude / dB	<u>82.4%</u>	<u>-32.0 dB</u>	<u>-7.2 dB</u>
Sweep	<u>1.85 in.</u>	<u>1.85 in.</u>	<u>1.85 in.</u>
Gain (dB)	<u>23.0</u>	<u>Log</u>	<u>+25 Log</u>
Screen	<u>Half Path</u>	<u>25 dB Booster</u>	<u>Active</u>

Channel Name 45° RL 04-302 P1/R1

General

Timebase Start 0.0 in. Range 4.0 in.

Units Half Path

Digitizer

Synchro Pulse A Scan Sample Size 8 Bit

Averaging 1 Acquisition Rate 301 Hz

Digitizing Frequency 12.5 MHz Max Recurrence 2000 Hz

Pulsar / Receiver

Configuration Conventional Pitch Catch

Pulsar P1 Receiver R1

Voltage 300 V Scale Type LOG

Width (Ns) 250 ns Rectification Unsigned

Smoothing 2 MHz

Probe

Wave Type Longitudinal Scan offset 0.00 in.

Velocity 0.2272 in./sec. Index offset 0.00 in.

Wedge Delay 9.675 usec. Angle 45°

Skew 0/180

Field Simulator CS Rompage S/N CAL-RHOM-095

Reflector Far SDH

Max Amplitude/dB -5.3 dB

Sweep 1.04"

Gain (dB) Log

Calibration Verification				
	Time	Date	Block(s)	Operator
Initial	<u>0900</u>	<u>4/11/2005</u>	<u>PIL 78</u>	<u>RJ</u>
Verified	<u>2216</u>	<u>4/25/2005</u>	<u>CAL-RHOM-095</u>	<u>KD</u>
Verified				
Verified				
Final	<u>0140</u>	<u>4/26/2005</u>	<u>CAL-RHOM-095</u>	<u>KD</u>

N2 - 45° RL - Ax Scan

Kyle Davidson I-L 4/26/2005
Operator Level Date

[Signature] III 4-28-05
Analyst Level Date

[Signature] UT III 4-29-05
Utility Review Level Date

[Signature] [Signature]
ANIII Review Date

Page 172/240



GE Energy, Nuclear

ULTRASONIC CALIBRATION DATA SHEET (Automated with Micro TomoScan)

Site Pilgrim Nuclear Power Unit 1 Project RF-015 Report Number APR-012 Calibration Sheet No. APC-067 Weld 2R-N2J-1

Procedure No. TP04-016 (GE-UT-209) Version R1 (V17) DRR N/A

Instrument Zetec / u Tomo 18121-09 2.2Q14 2.2Q14 Manufacturer / Model System Serial No. Acquisition Software Analysis Software Pulsar/Receiver R/D Tech EQTX 100 R/D Tech EQTX 101 Digitizer: R/D Tech EQTX 098 Main Board: Manufacturer / Model Piggy Board: Manufacturer / Model Search Unit RTD 04-310 2(10x18) mm 1.0 MHz 45° / RL 0.84" 45" 0.55" Manufacturer Serial No. Element Size Freq. (MHz) Angle / Mode FD,FS/SA,RA Measured Incident to Wedge Front Cable RG-58/RG-58/RG-174 250' / 25' / 3' 2 No. of Intermediate Connectors Calibration Standard PIL-78 SS/NC 1.3" 1.3" Serial No. Material Nominal Thickness Measured Thickness Thermometer 241878 75 °F Couplant Demin Water N/A Serial No. Temp (°F) Type Batch No.

Table with 3 columns for Calibration parameters: Orientation (Circ), Type (ID Notch), Depth (1.30 in), Amplitude / dB (83.9%), Sweep (1.85 in), Gain (dB) (37), Screen (Half Path).

Channel Name 45° RL 04-310 P1/R1 General Timebase Start 0.0 in. Range 4.0 in. Units Half Path

Digitizer Synchro Pulse [x] A Scan Sample Size 8 Bit Averaging 1 Acquisition Rate 301 Hz Digitizing Frequency 6.25 MHz Max Recurrence 2000 Hz

Pulsar / Receiver Configuration Conventional Pitch Catch Pulsar P1 Receiver R1 Voltage 300 V Scale Type LOG Width (Ns) 500 ns Rectification Unsigned Smoothing 1 MHz

Field Simulator CS Rompas S/N CAL-RHOM-095 Reflector Far SDH Max Amplitude/dB -17.3 dB Sweep 1.0" Gain (dB) + Log

Probe Wave Type Longitudinal Scan offset 0.00 in. Velocity 0.2272 in./sec. Index offset -2.70 in. Wedge Delay 11.170 usec. Angle 45° Skew 0/180

Table for Calibration Verification with columns: Time, Date, Block(s), Operator. Rows include Initial, Verified, and Final entries.

N2 - 45° RL - Circ Scan

Operator Richard Jasken II 4/27/2005 Analyst [Signature] III 4-28-05 Utility Review [Signature] III 4-29-05 ANIII Review [Signature] III 4-29-05 Page 10 of 13

Page 173/240



GE Energy, Nuclear

ULTRASONIC CALIBRATION DATA SHEET (Automated with Micro TomoScan)

Site Pilgrim Nuclear Power Unit 1 Project RF-015 Report Number APR-012 Calibration Sheet No. APC-068 Weld 2R-N2J-1

Procedure No. TP04-016 (GE-UT-209) Version R1 (V17) DRF N/A

Instrument Zetec / uTomo 18121-09 2.2Q14 2.2Q14 Manufacturer / Model System Serial No. Acquisition Software Analysis Software Pulser/Receiver R/D Tech EQTX 100 R/D Tech EQTX 101 Digitizer: R/D Tech EQTX 098 Main Board: Manufacturer / Model Piggy Board: Manufacturer / Model Search Unit RTD 04-305 2(10x18)mm 2.0 MHz 60°/RL 0.77" 61" 0.52" Manufacturer Serial No. Element Size Freq. (MHz) Angle / Mode FD,FS/SA,RA Measured Incident to Cable RG-58/RG-58/RG-174 250' / 25' / 3' Length 2 No. of Intermediate Connectors Calibration Standard CAL-DPTH-063 SS 0.8" 0.8" Serial No. Material Nominal Thickness Measured Thickness Thermometer 241878 75 °F Couplant Demin Water N/A Serial No. Type Batch No.

Calibration table with columns for Orientation, Type, Depth, Amplitude, Sweep, Gain, and Screen. Values include Circ, SDH, 0.80 in, 81.5%, 1.65 in, 24, Half Path, 25 dB Booster, and Active.

Channel Name 60° RL 04-305 P3 / R3 General Timebase Start 0.0 in Range 5.5 in Units Half Path

Digitizer Synchro Pulse A Scan Sample Size 8 Bit Averaging 1 Acquisition Rate 301 Hz Digitizing Frequency 12.5 MHz Max Recurrence 2000 Hz

Pulser / Receiver Configuration Conventional Pitch Catch Pulser P3 Receiver R3 Voltage 300 V Scale Type LOG Width (Ns) 250 ns Rectification Unstated Smoothing 2 MHz

Probe Wave Type Longitudinal Scan offset 0.00 in Velocity 0.2272 in/sec Index offset -5.20 in Wedge Delay 10.640 usec Angle 60° Skew 0/180

Field Simulator CS Rompas S/N CAL-RHOM-095 Reflector Far SDH Max Amplitude/dB -7.2 dB Sweep 1.55° Gain (dB) + Log

Calibration Verification table with columns for Time, Date, Block(s), and Operator. Rows include Initial, Verified, and Final entries.

N2 - 60° RL - Ax Scan

Operator Kyle Davidson I-L 4/26/2005 Analyst [Signature] Level Date 4-28-05

Utility Review [Signature] Level Date ANIII Review [Signature] Date

Page 174/240



GE Energy, Nuclear

ULTRASONIC CALIBRATION DATA SHEET (Automated with Micro TomoScan)

Site Pilgrim Nuclear Power Unit 1

Project RF-015

Report Number APR-012

Calibration Sheet No. APC-069

Weld 2R-N2J-1

Procedure No. TP04-016 (GE-UT-209)

Version R1 (V17) DRP N/A

Instrument Zetec / uTomo 18121-09 2.2Q14 2.2Q14
Manufacturer / Model System Serial No. Acquisition Software Analysis Software
Pulsar/Receiver R/D Tech EQTX 100 Pulsar/Receiver R/D Tech EQTX 101 Digitizer: R/D Tech EQTX 098
Main Board: Manufacturer / Model Piggy Board: Manufacturer / Model
Search Unit RTD 00-349 2(10x18) mm 1.0 MHz 60° / RL 0.59" 60" 0.50"
Manufacturer Serial No. Element Size Freq. (MHz) Angle / Mode FD,FS/SA,RA Measured Incident to
Cable RG-58/RG-58/RG-174 250' / 25' / 3' 2 No. of Intermediate Connectors
Type Length
Calibration Standard CAL-DPTH-063 SS 0.6" 0.6"
Serial No. Material Nominal Thickness Measured Thickness
Thermometer 241878 75 °F Couplant Demin Water N/A
Serial No. Temp (°F) Type Batch No.

Calibration

Orientation Circ Circ Circ
Type SDH SDH SDH
Depth 0.60 in. 0.60 in. 0.60 in.
Amplitude / dB 84.3% -42.0 dB -18.8 dB
Sweep 1.18 in. 1.18 in. 1.18 in.
Gain (dB) 32 Log +25 Log
Screen Half Path 25 dB Booster Active

Channel Name 60° RL 00-349 P3 / B3

General

Timebase Start 0.0 in. Range 5.5 in.
Units Half Path

Digitizer

Synchro Pulse [X] A Scan Sample Size 8 Bit
Averaging 1 Acquisition Rate 301 Hz
Digitizing Frequency 6.25 MHz Max Recurrence 2000 Hz

Pulsar / Receiver

Configuration Conventional Pitch Catch
Pulsar P3 Receiver B3
Voltage 300 V Scale Type LOG
Width (Ns) 500 ns Rectification Unsigned
Smoothing 1 MHz

Probe

Wave Type Longitudinal Scan offset -5.20 in.
Velocity 0.2272 in./sec. Index offset -2.70 in.
Wedge Delay 10.240 msec. Angle 60°
Skew 0/180

N2 - 60° RL - Circ Scan

Field Simulator CS Rompas S/N CAL-RHOM-095

Reflector Near SDH N/A
Max Amplitude/dB -18.8 dB N/A
Sweep 0.78" N/A
Gain (dB) + Log N/A

Calibration Verification

Table with columns: Time, Date, Block(s), Operator. Rows: Initial (0739, 4/23/2005, CAL-DPTH-063, RJ), Verified (0155, 4/26/2005, CAL-RHOM-095, KD), Verified, Verified, Final (1107, 4/27/2005, CAL-RHOM-095, RJ).

Richard Jasken II 4/27/2005
Operator Level Date
Analyst [Signature] III 4-28-05
Level Date

Utility Review [Signature] Level Date 4-29-05
ANIII Review [Signature] Date 4/29/05

Page 175/240



GE Energy, Nuclear

Micro-Tomo (Smart 2000) - Auto Piping Weld Examination Checklist

**Pilgrim Unit 1, 2005
2R-N2J**

2R2JZ10 LKDN	Load appropriate setup	Offsets entered into TV correctly	Transducers Skewed IAW Procedure	Files named IAW Scanplan	360° contact achieved	360° Circ coverage achieved	Full Volume Ax Coverage Achieved	Scan saved to computer HD Verified readable	Data transferred to DA Verified received by DA	Data Reviewed	Analysis Complete	Package Complete	<u>NOTES:</u>
45° Shear	<input checked="" type="checkbox"/>	<input checked="" type="checkbox"/>	<input checked="" type="checkbox"/>	<input checked="" type="checkbox"/>	<input type="checkbox"/>	<input type="checkbox"/>	<input type="checkbox"/>	MW	MW	MJK	MJK	MJK	
45° RL	<input checked="" type="checkbox"/>	<input checked="" type="checkbox"/>	<input checked="" type="checkbox"/>	<input checked="" type="checkbox"/>	<input type="checkbox"/>	<input type="checkbox"/>	MJK			MJK	MJK		
60° RL	<input checked="" type="checkbox"/>	<input checked="" type="checkbox"/>	<input checked="" type="checkbox"/>	<input checked="" type="checkbox"/>	<input type="checkbox"/>	<input type="checkbox"/>	MJK			MJK	MJK		
2R2JZ20 LKUP	Load appropriate setup	Offsets entered into TV correctly	Transducers Skewed IAW Procedure	Files named IAW Scanplan	360° contact achieved	360° Circ coverage achieved	Full Volume Ax Coverage Achieved	Scan saved to computer HD Verified readable	Data transferred to DA Verified received by DA	Data Reviewed	Analysis Complete	Package Complete	<u>NOTES:</u>
45° Shear	<input checked="" type="checkbox"/>	<input checked="" type="checkbox"/>	<input checked="" type="checkbox"/>	<input checked="" type="checkbox"/>	<input type="checkbox"/>	<input type="checkbox"/>	<input type="checkbox"/>	MW	MW	MJK	MJK	MJK	
45° RL	<input checked="" type="checkbox"/>	<input checked="" type="checkbox"/>	<input checked="" type="checkbox"/>	<input checked="" type="checkbox"/>	<input type="checkbox"/>	<input type="checkbox"/>	MJK			MJK	MJK		
60° RL	<input checked="" type="checkbox"/>	<input checked="" type="checkbox"/>	<input checked="" type="checkbox"/>	<input checked="" type="checkbox"/>	<input type="checkbox"/>	<input type="checkbox"/>	MJK			MJK	MJK		
2R2JZ30 LKCW	Load appropriate setup	Offsets entered into TV correctly	Transducers Skewed IAW Procedure	Files named IAW Scanplan	360° contact achieved	360° Circ coverage achieved	Full Volume Ax Coverage Achieved	Scan saved to computer HD Verified readable	Data transferred to DA Verified received by DA	Data Reviewed	Analysis Complete	Package Complete	<u>NOTES:</u>
45° Shear	<input checked="" type="checkbox"/>	<input checked="" type="checkbox"/>	<input checked="" type="checkbox"/>	<input checked="" type="checkbox"/>	<input type="checkbox"/>	<input type="checkbox"/>	<input type="checkbox"/>	SG	SG	MJK	MJK	MJK	
45° RL	<input checked="" type="checkbox"/>	<input checked="" type="checkbox"/>	<input checked="" type="checkbox"/>	<input checked="" type="checkbox"/>	<input type="checkbox"/>	<input type="checkbox"/>	MJK			MJK	MJK		
60° RL	<input checked="" type="checkbox"/>	<input checked="" type="checkbox"/>	<input checked="" type="checkbox"/>	<input checked="" type="checkbox"/>	<input type="checkbox"/>	<input type="checkbox"/>	MJK			MJK	MJK		
2R2JZ40 LKCCW	Load appropriate setup	Offsets entered into TV correctly	Transducers Skewed IAW Procedure	Files named IAW Scanplan	360° contact achieved	360° Circ coverage achieved	Full Volume Ax Coverage Achieved	Scan saved to computer HD Verified readable	Data transferred to DA Verified received by DA	Data Reviewed	Analysis Complete	Package Complete	<u>NOTES:</u>
45° Shear	<input checked="" type="checkbox"/>	<input checked="" type="checkbox"/>	<input checked="" type="checkbox"/>	<input checked="" type="checkbox"/>	<input type="checkbox"/>	<input type="checkbox"/>	<input type="checkbox"/>	SG	SG	MJK	MJK	MJK	
45° RL	<input checked="" type="checkbox"/>	<input checked="" type="checkbox"/>	<input checked="" type="checkbox"/>	<input checked="" type="checkbox"/>	<input type="checkbox"/>	<input type="checkbox"/>	MJK			MJK	MJK		
60° RL	<input checked="" type="checkbox"/>	<input checked="" type="checkbox"/>	<input checked="" type="checkbox"/>	<input checked="" type="checkbox"/>	<input type="checkbox"/>	<input type="checkbox"/>	MJK			MJK	MJK		

Notes: Transducer liftoff due to the outside surface contour. See the data sheet for parameters

Page 176/240

MJK 11/11/05 4-29-05

UT CALIBRATION DATA SHEET

C.D.S. NO. 99-C-547
 U.T.V. NO. 0027A
 L.D.S. NO. 99-L-351

PROCEDURE NO. QAI 50.71 REV. 4 DATE 5/22/99
 CALIBRATION PERSONNEL: NAME Paul Visher LEVEL II NAME John Thayer LEVEL II
 INSTRUMENT DATA: MAKE STANLEY MODEL 5000 126 SERIAL NO. 126-5496
 ARCH UNIT DATA: MANUFACTURER KBA TYPE M3WQL GAMMA
 SERIAL NO. 002447 SIZE .50" FREQUENCY 225 MHz
 BEAM ANGLE 45° BEAM MODE SWEEP WEDGE TYPE LUCITE
 TABLE DATA: LENGTH 6' TYPE 26-17A
 IMPLANT DATA: TYPE ULTRABEL II BATCH NO. 98275
 CALIBRATION STANDARD DATA: SERIAL NO. PA-17A THICKNESS 1.0" DIAMETER 12"
 MATERIAL CS SA-106 GR. B
 CALIBRATION REFLECTOR(S) DATA: TYPE Notch SIZE .100" x .125" x 1.0"
 ORIENTATION (TO PIPE AXIS) Circle
 OR DUAL ELEMENT TRANSDUCERS: SPLIT ORIENTATION (TO HOLE CENTERLINE) FOR
 MAXIMUM RESPONSE
 PARALLEL AMPLITUDE N/A TRANSVERSE AMPLITUDE N/A

C CURVE-SCREEN REPRESENTATION

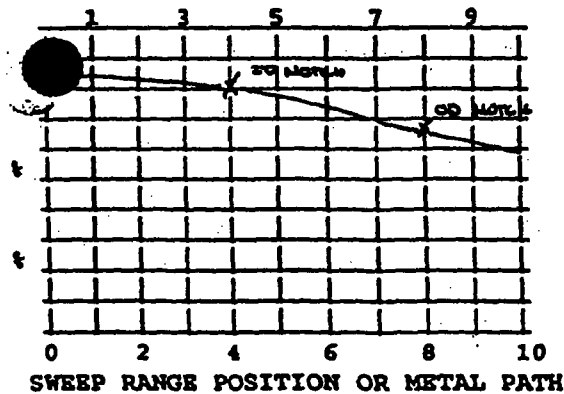

CALIBRATION TIME - RECORDS					
00	01	02	03	04	05
ORIG. CAL.	CAL.	LAST	LAST	VERIFY	
DATE	CAL.	CHECK - E.D.S.	E.D.S.	25°F LIMIT	
TIME	TIME	#	LINE #	YES/NO	
5/22/99	1100	1535	99-E-548 (4)	292	YES

I.D. OF WELD/COMPONENT

G-NAA-1
G-NAB-1
G-NAC-1
G-NAD-1

TD @ 27° @ 40° @ 32.0dB
 OD @ 63° @ 80° @ 32.0dB

REFERENCE GAIN 32.0dB
 SCANNING GAIN 46.0dB

REVIEWED BY: Chad Thayer L.O. III DATE 5/25/99
 DATA REVIEWER

ASME SECTION XI EXAMINATION: X YES - ANII SIGNATURE REQUIRED
 _____ NO - ANII SIGNATURE NOT REQUIRED

ACCEPTED BY: B Perkins DATE 5/26/99
 BECO LEVEL III OR DESIGNEE

REVIEWED BY: [Signature] DATE 5-26-99
 ANII

BOSTON EDISON COMPANY
ULTRASONIC EXAMINATION DATA SHEET

Exam proc. 5011 Rev. 4

EXAMINATION PERSONNEL:

Name [Signature] Level II

M. R. No. 19702057

EDS No. 99-E-548

Name [Signature] Level II

Couplant ULTRACON II 98325

CDS No. 99-C-547

Scanning Gain 45.0dB

L.D.S. 99-L-351

UTV No. 0027A

Beam Angle 45°

(W) DIMENSION (L) DIMENSION

DATE 5/26/99

WELD COMP#	CONFIG	IND #	SCAN NO. DIRECTION & SURFACE	MAX. AMP.	LO WO	W _m SP _m	L ₁ SP _{L1}	L _m	L ₂ SP _{L2}	TIME OF EXAM START	STOP	COMP. TEMP.	REMARKS
6-N4A-1	SE-NOZ	N/A	I/+/-							1337	1342	78°F	NRI
6-N4A-1	SE-NOZ	N/A	I/-/+			N				1342	1347	78°F	NRI
6-N4B-1	SE-NOZ	N/A	I/+/-				A			1245	1250	78°F	NRI
6-N4B-1	SE-NOZ	N/A	I/-/+							1250	1255	75°F	NRI
	N	A			N			A			N	A	

Components meet ASME Section XI Acceptance Criteria: Yes

ASME Section XI Examination:

YES NO → FURTHER EVALUATION REQUIRED

YES-ANII Signature Required
 NO-ANII Signature Not Required

REMARKS: A) LIMITED EXAMINATION BETWEEN 26.875" TO 27.625" AND 31.875" TO 32.625" DUE TO THERMO COUPLER PINS ON WELDS

Evaluated By: [Signature] Level III Date 5/25/99

Accepted By: [Signature] Level III Date 5/26/99
BeCo Level III or Designee

ANII Review By: [Signature] Date 5-26-99

log 178/240

BOSTON EDISON COMPANY
ULTRASONIC EXAMINATION DATA SHEET

EXAMINATION PERSONNEL:

Name *R. Allen* Level *II*
Name *Samir Nasir* Level *IV*

M. R. No. 19702067
Couplant *Ultrasonic II 98325*
Scanning Gain 450dB

Exam proc. 50-71 Rev. 4

EDS No. 99-E-548
CDS No. 99-C-547
L.D.S. 99-L-351
UTV No. 0021A
DATE 5/22/99

Beam Angle 45°

(W) DIMENSION (L) DIMENSION

WELD COMP#	CONFIG	IND #	SCAN NO. DIRECTION & SURFACE	MAX. AMP.	LO WO	W _m SP _m	L ₁ SP _{L1}	L _m	L ₂ SP _{L2}	TIME OF EXAM		COMP. TEMP.	REMARKS
										START	STOP		
G-N4C-1	6E-N02	N/A	I/+/-							1310	1315	78°F	N) U21
G-N4C-1	6E-N02	N/A	I/-/+							1315	1320	78°F	N) U21
G-N4D-1	6E-N02	N/A	I/+/-							1402	1407	78°F	U21
G-N4D-1	6F-N02	N/A	I/-/+							1407	1412	78°F	U21

Components meet ASME Section XI Acceptance Criteria:

ASME Section XI Examination:

YES NO → FURTHER EVALUATION REQUIRED

YES-ANII Signature Required
 NO-ANII Signature Not Required

REMARKS: LIMITED EXAMINATION BETWEEN 26.75° TO 29.75° AND
31.75° TO 33.75° DUE TO TYPICAL COUPLANT PATCH ON WELD.

Evaluated By: *D. Thomas* Level *III* Date 5/26/99

Accepted By: *B. P. ...* Level *III* Date 5/26/99
BeCo Level III or Designee

ANII Review By: *V. ...* Date 5-26-99

Box 179/240

UT CALIBRATION DATA SHEET

C.D.S. NO 99-C-549
 U.T.V. No 0021A
 L.D.S. NO 99-L-351

PROCEDURE NO. QCI 5071 REV. 4 DATE 5/22/99
 EXAMINATION PERSONNEL: NAME R. Walden LEVEL II NAME John Miller LEVEL II
 INSTRUMENT DATA: MAKE SONOTEST MODEL 6mm 126 SERIAL NO. 126-5496
 ARCH UNIT DATA: MANUFACTURER Y2A TYPE M509C GAMMA
 SERIAL NO. 0021A SIZE .60" FREQUENCY 2.25 MHz
 BEAM ANGLE 60° BEAM MODE SEAL WEDGE TYPE Luxite
 REFLECTOR DATA: LENGTH 12' TYPE PL-17A
 REFLECTOR DATA: TYPE ULTRASOUND BATCH NO. 58325
 REFLECTOR STANDARD DATA: SERIAL NO. PL-17A THICKNESS 1.00 DIAMETER 12"
 MATERIAL C6 SA-106 GR. B
 REFLECTOR REFLECTOR(S) DATA: TYPE None SIZE 100° d x 175° w x 10° l
 ORIENTATION (TO PIPE AXIS) Circ
 REFLECTOR DUAL ELEMENT TRANSDUCERS: SPLIT ORIENTATION (TO HOLE CENTERLINE) FOR
 MAXIMUM RESPONSE
 PARALLEL AMPLITUDE N/A TRANSVERSE AMPLITUDE N/A

C CURVE-SCREEN REPRESENTATION

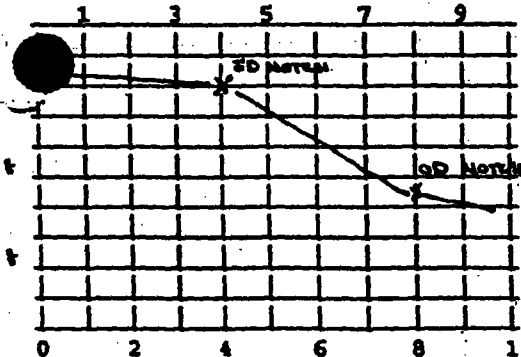

CALIBRATION TIME - RECORDS

00	01	02	03	04	05
ORIG.	CAL.	LAST	LAST	VERIFY	
DATE	CAL.	CHECK-	E.D.S.	E.D.S.	25°F LIMIT
TIME	TIME	#	LINE #	YES/NO	
<u>5/22/99</u>	<u>1055</u>	<u>1838</u>	<u>99-E-350(4)</u>	<u>pg 2</u>	<u>YES</u>

I.D. OF WELD/COMPONENT

6-NAA-1
6-NAB-1
6-NAC-1
6-NAD-1
Dover

SWEEP RANGE POSITION OR METAL PATH

FD @ 70° @ 40° @ 512 dB
SD @ 41° @ 20° @ 512 dB
REFERENCE GAIN 61.2 dB
SCANNING GAIN 60.0 dB

REVIEWED BY: [Signature] DATE 5/25/99
 DATA REVIEWER

ASME SECTION XI EXAMINATION; YES - ANII SIGNATURE REQUIRED
 NO - ANII SIGNATURE NOT REQUIRED

ACCEPTED BY: [Signature] DATE 5/26/99
 BECO LEVEL III OR DESIGNEE

REVIEWED BY: [Signature] DATE 5/26/99
 ANII

BOSTON EDISON COMPANY
ULTRASONIC EXAMINATION DATA SHEET

EXAMINATION PERSONNEL:

Name [Signature] Level II

Name [Signature] Level IV

Beam Angle 60°

M. R. No. 19702067
Couplant Ultrasol II 98375
Scanning Gain 600

Exam proc. So. 11 Rev. 4

EDS No. 99-E-550
CDS No. 99-C-549
L.D.S. 99-L-351
UTV No. 6027A
DATE 5/26/99

(W) DIMENSION (L) DIMENSION

WELD COMP#	CONFIG	IND #	SCAN NO. DIRECTION & SURFACE	MAX. AMP.	LO WO	W _m SP _m	L ₁ SP _{L1}	L _m	L ₂ SP _{L2}	TIME OF EXAM START	STOP	COMP. TEMP.	REMARKS
G-N4A-1	SE-NOZ	N/A	I/+/-							1347	1353	78°F	N21
G-N4A-1	SE-NOZ	N/A	I/-/+			N				1353	1359	78°F	N21
G-N4B-1	SE-NOZ	N/A	I/+/-				A			1255	1301	78°F	N
G-N4B-1	SE-NOZ	N/A	I/-/+							1301	1307	78°F	N
	N	A				N	A				N	A	

Components meet ASME Section XI Acceptance Criteria: Yes

ASME Section XI Examination:

YES NO FURTHER EVALUATION REQUIRED

X YES-ANII Signature Required
NO-ANII Signature Not Required

REMARKS: A) LIMITED EXAMINATION BETWEEN 26.875" TO 29.625" AND 31.875" TO 34.625" DUE TO THERMO COUPLE PASS ON WELD.

Evaluated By: [Signature] Level III Date 5/26/99

Accepted By: [Signature] Level III Date 5/26/99
BeCo Level III or Designee

ANII Review By: [Signature] Date 5-16-99

Page 24
18/240

BOSTON EDISON COMPANY
ULTRASONIC EXAMINATION DATA SHEET

EXAMINATION PERSONNEL:

Name A. Walden Level II
Name F. Mininasa Level II
Beam Angle 60°

M. R. No. 19702057
Couplant ULTRAC-11 98375
Scanning Gain 60.0

Exam proc. 6071 Rev. 4
EDS No. 99-E-550
CDS No. 99-C-549
L.D.S. 99-L-351
UTV No. 00274
DATE 5/26/99

(W) DIMENSION (L) DIMENSION

WELD COMP#	CONFIG	IND #	SCAN NO. DIRECTION & SURFACE	MAX. AMP.	LO WO	W _n SP _n	L ₁ SP _{L1}	L _n	L ₂ SP _{L2}	TIME OF EXAM START	STOP	COMP. TEMP.	REMARKS
G-NAL-1	5E-NOZ	N/A	I/+/-							1320	1326	78°F	N NBI
G-NAL-1	5E-NOZ	N/A	I/-/+				N			1326	1332	78°F	N NBI
G-NAD-1	6E-NOZ	N/A	I/+/-				A			1412	1418	78°F	NBI
G-NAD-1	6E-NOZ	N/A	I/-/+							1418	1424	78°F	NBI
		N	A			N	A				N	A	

Components meet ASME Section XI Yes Acceptance Criteria:

ASME Section XI Examination:

YES NO → FURTHER EVALUATION REQUIRED

X YES-ANII Signature Required
NO-ANII Signature Not Required

REMARKS: A) Limited Examination Between 24.75" to 25.75" AND 26.75" to 28.75" DIA. To Insure Coube Fit on Weld

Evaluated By: P. Hesse Level III Date 5/26/99

Accepted By: B. Pauli Level III Date 5/26/99
BeCo Level III or Designee

ANII Review By: V. G. F. C. Date 5-26-99

Page 183/240

BOSTON EDISON COMPANY
RECORD OF MAGNETIC PARTICLE EXAMINATION

DATA SHEET #
97-M-119

ITEM ID/PIECE # RPV-SBW-0	SYSTEM <u>54</u> LOCATION <u>DAYWELL</u>	MR # 19600309	ISO/DWG NUMBER ISI-1-54-1
------------------------------	---	------------------	------------------------------

A. MATERIAL	TYPE <u>C.S.</u>
-------------	------------------

CROSS SECTION THICKNESS	MAX	MIN	GEOMETRY	PIPE	PLATE <u>X</u>	ROD	OTHER
-------------------------	-----	-----	----------	------	----------------	-----	-------

FABRICATION PROCESS	CAST	WORKED	<u>WELDED</u>	OTHER
---------------------	------	--------	---------------	-------

SURFACE	MACHINED GROUND	<u>AS FABRICATED</u>	OTHER	INSPECTION HOLD PT <u>FINAL ISI</u>
---------	-----------------	----------------------	-------	--

SURFACE IS SUITABLE FOR SCHEDULED X MT N/A AUT EXAMINATION: YES/NO

SKETCH OR OTHER DETAIL ATTACHED	YES <u>NO</u>	WEIGHT	<u>X</u> 10 LB. <u>40</u> LB
---------------------------------	---------------	--------	------------------------------

B. PROCEDURE # VALIDATION # POLE SPACING	<u>QCI 50.20</u> <u>N/A</u> <u>6" MAX</u>	EQUIPMENT IDENTIFICATION <u>X</u> AC <u>HWAC</u> <u>SIN 5156</u>
--	---	--

C. EVALUATION

LOCATION	SIZE (INCHES)	DESCRIPTION	ACTION (ACCEPT, REWORK, REJECT AND COMMENT AS NECESSARY.)
1		<u>NRI - ACCEPT</u>	<u>EXAMINED 12" OF TOP SURFACE</u>
2			
3			
4			
5			
6			
7			

D. CRITERIA	<u>ASME SECT. XI 1989</u>
-------------	---------------------------

COMPONENTS ~~MEET~~/DO NOT MEET ASME SECTION XI ACCEPTANCE CRITERIA, FURTHER EVALUATION REQUIRED: YES X NO

E. ATTEST	<u>D. M. Wood</u> <u>II</u> <u>3/5/97</u> RESPONSIBLE CERTIFIED PERSONNEL LEVEL DATE
	<u>B. Perkins</u> <u>3/5/97</u> <u>III</u> <u>3/6/97</u> REVIEWED BY: <u>M. J. ...</u> DATE ANIY DATE



Calibration Data Sheet

CDS No: 05-C-450
 LDS No: 05-L-422-151
 Page: 1 of 1

Plant/Unit: DILLON STATION
 System: RHR A
 Component: 10-1A-15 / 10-1A-14
 Line No.: 1B-DCA-10
 Procedure: END-NDE 9.23 Rev.: 0
 Thermometer SN: 230
 Cal. Blk Temp.: 64 Comp Temp.: 75
 Cal. Block No.: D16 23A
 Carbon Steel Stainless Steel
 Size: 18 Sch.: 755
 Cal Direction Axial Circ Both
 Scan Area ⊥ to weld
 Scan Area || to weld

Work Order: 03116631
 DWG No.: ISI-I-1-10

Cal Checks	Time
Initial Cal.:	<u>1104 / 1105</u>
Date:	<u>4/29/05</u>
Inter. Cal.:	
Date:	
Inter. Cal.:	
Date:	
Final Cal.:	<u>1752 / 1753</u>
Date:	<u>4/29/05</u>

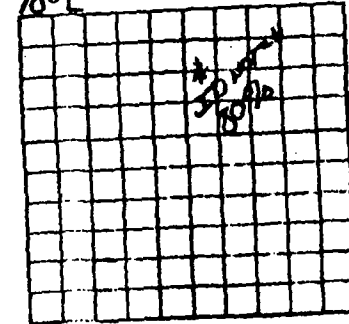
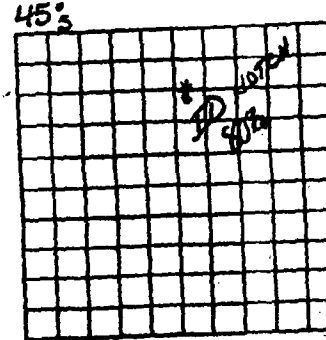

Search Unit # 1
 Manufacturer: KBA
 Model: Comp 6
 Serial No.: 0075C4
 Size: .375 Shape: Round
 Freq.: 15 # Elm: 1
 Angle: 45 Mode: SILEN
 Measured Angle: 45°

Search Unit # 2
 Manufacturer: RTD
 Model: TRL2
 Serial No.: 00-727
 Size: 2(5x14) Shape: SP
 Freq.: 2 # Elm: 2
 Angle: 70 Mode: LOWE
 Measured Angle: 70

Wedge Style: MSWQC
Search Unit Cable
 Type: RG-174
 Length: 6.0' # Con.: 0

Wedge Style: INTEGRAL
Search Unit Cable
 Type: RG-174
 Length: 6.0' # Con.: 0

Instrument Settings
 Manufacturer: STAVELEY
 Model: SONIC 136
 Serial No.: 136P1200404157
 Linearity Due: 5/2/05
 Delay: .283 Range: 2.0
 Mtl. Vel.: .123 Pulsar: 334
 Damping: 500 Reject: OFF
 Rep Rate: 4K Freq.: 2.25
 Filter: 2 Mode: P/E

Instrument Settings
 Manufacturer: STAVELEY
 Model: SONIC 136
 Serial No.: 136P1200404157
 Linearity Due: 5/2/05
 Delay: .943 Range: 4.0
 Mtl. Vel.: .250 Pulsar: 250
 Damping: 500 Reject: OFF
 Rep Rate: 4K Freq.: 2.25
 Filter: 2 Mode: DUAL

Couplant

Type: ULTRAGEL II
 Batch: 01225

Examination Area / Weld	Access	Recordable Indications			Exam Sens.
		Yes	No	Geom.	
<u>10-1A-14</u>	<u>SINGLE SIDE</u>	<u>N/A</u>	<u>X</u>	<u>NO</u>	<u>57.6</u> <u>72.8</u>
<u>10-1A-15</u>	<u>SINGLE SIDE</u>	<u>N/A</u>	<u>X</u>	<u>NO</u>	<u>57.6</u> <u>72.8</u>

Remarks:
 Further Evaluation Required: Yes No

Examiner: [Signature] Level: II Date: 4/30/05
 Examiner: [Signature] Level: Date:
 Reviewer: [Signature] Level: III Date: 4/30/05
 ANII: [Signature] Date: 5/1/05

Reference Sensitivity
 Axial: 29.6 Circ: 29.6

Reference Sensitivity
 Axial: 70.8 Circ: N/A

Page 184/240



Examination Data Sheet

EDS No: 05-E-451-151
 CDS No: 05-C-450-151
 LDS No: 05-L-422-151
 Page: 1 of 2

Plant/Unit: <u>PILGRIM STATION</u>	System: <u>RHR-A</u>	Component: <u>10-1A-14</u>	Procedure: <u>END-NDE-9.23</u>
Work Order: <u>03116631</u>	DWG No.: <u>ISI-I-10</u> ^{10-1 mm s/dw}	<input type="checkbox"/> Carbon Steel <input checked="" type="checkbox"/> Stainless Steel	Revision: <u>0</u>
Examination Area / Weld No.: <u>10-1A-14</u>	Line No.: <u>18"-DCA-10</u>	Size: <u>18"</u> Schedule: <u>1755</u>	Start Time/Date: <u>1345</u> ^{4/29/05} Finish Time/Date: <u>1415</u> ^{4/29/05}
			Lo Location: <u>TDC</u> Wo Location: <u>E</u>

Ind. #	Angle	% of DAC	Indication Length			Max Location		OD SU Loc.	Scan Direct.	Remarks:
			L1	L Max	L2	W	MP			
<u>NFI</u>										

Further Evaluation Required: Yes No Limitations: SINGLE SIDE EXAM 50% COVERAGE

Remarks

Examiner: <u>[Signature]</u> Level: <u>II</u> Date: <u>4/30/05</u>	Examiner: <u>N/A</u> Level: <u> </u> Date: <u> </u>
Reviewer: <u>[Signature]</u> Level: <u>III</u> Date: <u>4/30/05</u>	ANI: <u>[Signature]</u> Date: <u>5/7/05</u>

Page 185/240



Sketch Sheet

Data Sheet No: 05-E-451-151

Page: 2 of 2

Plant/Unit: <u>PILGRIM STATION</u>	System: <u>RHR A</u>	Component: <u>10-1A-14</u>	Procedure: <u>END-NDE-9.25</u> Revision: <u>0</u>
Examination Area / Weld No.: <u>10-1A-14</u>	DWG No.: <u>10-1 ^{WPS} ₅₇₅₀₅</u> <u>ISI-I-1-10</u>	Line No.: <u>18" OCA-10</u>	Work Order: <u>03116631</u>

PIPE

FLUED HEAD
X51A

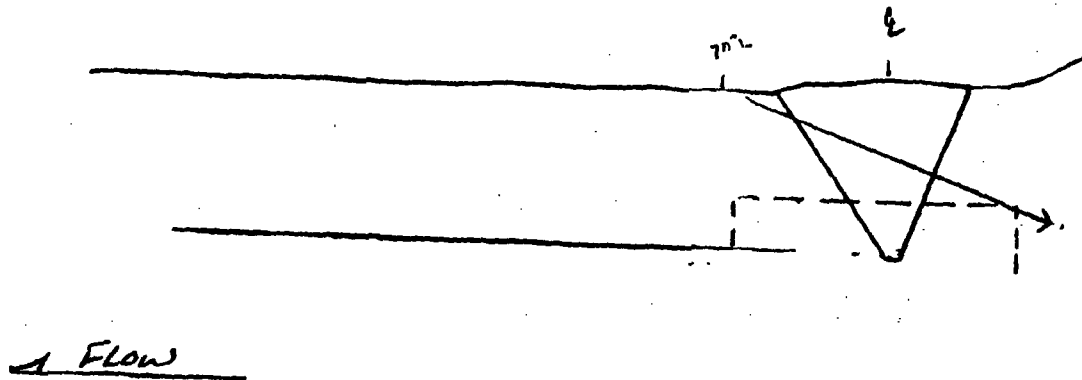

Examiner: [Signature] Level: II Date: 4/30/05

Examiner: N/A Level: Date:

Reviewer: [Signature] Level: III Date: 4/30/05

ANII: [Signature] Date: 5/10/05

Page 186/240



Examination Data Sheet

EDS No: 05-E-452-151
 CDS No: 05-C-450-151
 LDS No: 05-L-422-151
 Page 52 of 7
 5/1/05

Plant/Unit: <u>PILGRIM STATION</u>			System: <u>RHR - A</u>				Component: <u>10-1A-15</u>			Procedure: <u>END-NDE 923</u>				
Work Order: <u>03116631</u>			DWG No.: <u>10-1 gms</u> <u>ISI-I-1-10 5/1/05</u>				<input type="checkbox"/> Carbon Steel <input checked="" type="checkbox"/> Stainless Steel			Revision: <u>0</u>				
Examination Area / Weld No.: <u>10-1A-15</u>			Line No.: <u>18"-DCA-10</u>				Size: <u>18"</u> Schedule: <u>.755</u>			Start Time/Date: <u>1416 4/20/05</u> Finish Time/Date: <u>1441 4/29/05</u>				
Ind. #	Angle	% of DAC	Indication Length			Max Location		OD SU Loc.	Scan Direct.	Remarks:				
			L1	L Max	L2	W	MP							
<u>NDA</u>														
Further Evaluation Required: <input type="checkbox"/> Yes <input checked="" type="checkbox"/> No								Limitations: <u>SINGLE SIDE EXAM 50% COVERAGE</u>						
Remarks														
Examiner: <u>[Signature]</u>				Level: <u>II</u>				Date: <u>4/30/05</u>				Examiner: <u>NA</u>	Level: _____	Date: _____
Reviewer: <u>[Signature]</u>				Level: <u>III</u>				Date: <u>4/20/05</u>				ANII: <u>[Signature]</u>	Date: <u>5/1/05</u>	

Page 187/240



Sketch Sheet

Data Sheet No: 05-6-452-131

Page: 2 of 2

Plant/Unit: <u>PILGRIM STATION</u>	System: <u>RHR-A</u>	Component: <u>10-1A-15</u>	Procedure: <u>END-NDE-9.23</u> Revision: <u>0</u>
Examination Area / Weld No.: <u>10-1A-15</u>	DWG No.: <u>ISI-I-1-10</u> ^{10-1 WAS status}	Line No.: <u>18" DCA-1D</u>	Work Order: <u>03116631</u>

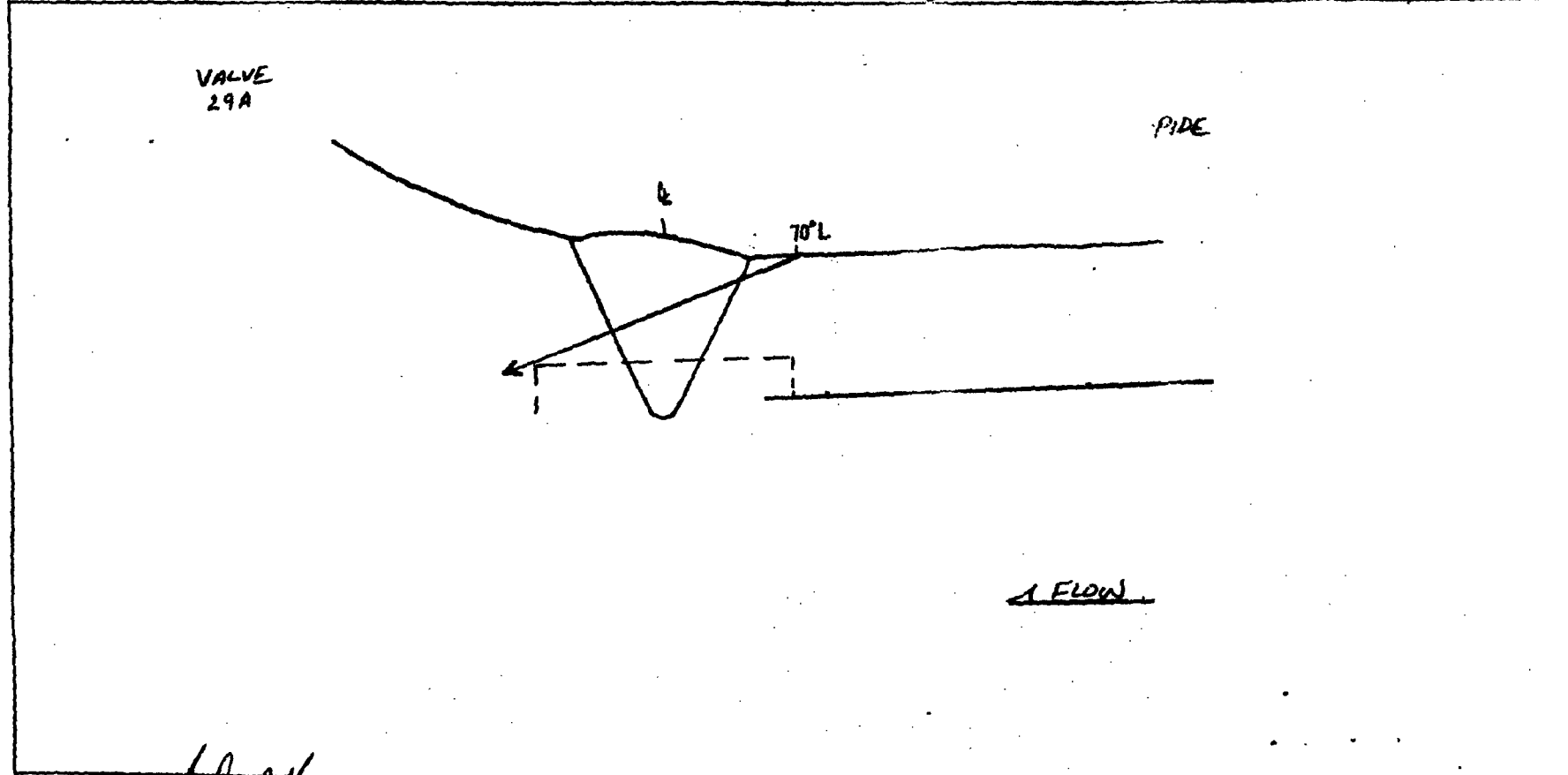

Examiner: <u>[Signature]</u> Level: <u>II</u> Date: <u>4/30/05</u>	Examiner: <u>N/A</u> Level: <u> </u> Date: <u> </u>
Reviewer: <u>[Signature]</u> Level: <u>III</u> Date: <u>4/30/05</u>	ANII: <u>[Signature]</u> Date: <u>[Signature]</u>

Page 188 1240



Calibration Data Sheet

Figure 5

Plan/Unit Pilgrim 1
Company Scientech

Comp/System 10A-1A-6

Procedure No. 50.87

Rev/Chng. No. 1

Cal. Block No. 7-1-64

Cal. Block Temp 19 Therm S/N

Size 1 1/2" Sch. 0.755 "T"

Ferritic Austenitic

Each Major CRT Div. = .3"/.5"

Cal. Direction: Axial Circ. Both

Scan Area: 1 to Weld

11 to Weld

CDS 03-C-126135

LDS 03-L-123 8P 4/22/03

Page 1 of 1

Cal. Checks	Time
Initial Calib.	1335
Initial Calib. Date	4/21/03
Intermediate	
Intermediate	
Final Calib.	1432
Final Calib. Date	4/21/03

Couplant

Type: Ultragel II

Batch: 00325

80%

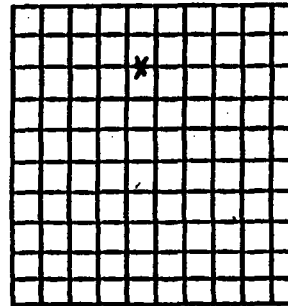

Search Unit #1

Manufacture: KBA
Serial No.: 00W8K0
Size: 0.50" Shape: round
Freq: 1.5 MHz Style:
Exam Angle: 45° Mode: Shear
Measured Angle: 45°
Wedge Style: MSWQC

80%

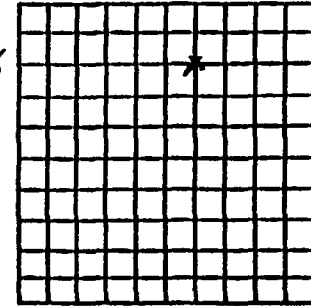

Search Unit #2

Manufacture: Megasonics
Serial No.: J111
Size: 2(25x50) Shape: rect
Freq: 2 MHz Style: GGP
Exam Angle: 60° Mode: Long
Measured Angle: 60°
Wedge Style: integral

Search Unit Cable

Type: RG-174
Length: 6' No. 0

Search Unit Cable

Type: RG-174
Length: 6' No. 0

Instrument Settings

Make/Model: Stavely/Sonic 136
Serial No.: 850K
Delay: .459 Range:
M'l Cal/Vol: .125 Pulser: 331us
Damping: 500Ω Reject: OFF
Rep. Rate: 4 KHz Freq: 2.25
Filter: 1 Mode: P-E
Reference Sensitivity (Sens.)
Axial: 32.4 Circ: 37.4
SCAN SENS: 36.4

Instrument Settings

Make/Model: Stavely/Sonic 136
Serial No.: 850K
Delay: .630 Range: 3.0"
M'l Cal/Vol: .235 Pulser: 250
Damping: 500Ω Reject: OFF
Rep. Rate: 4 KHz Freq: 2.25
Filter: 1 Mode: Real
Reference Sensitivity (Sens.)
Axial: 69dB Circ: 1/1A
SCAN SENS: 69dB

Examination Area/Weld	Access	Recordable Indications			Exam Sens.
		Yes	No	Geom	
10A-1A-6	UPST		X		38.4
10A-1A-6	UPST	X		X	69
	N				
	A				

Remarks/Reason for Incomplete Scan(s)
① Single sided exam due to component configuration (Pipe to Valve)
② Maintained 5-20% ID roll

Examiners: [Signature] Level II Date 4/21/03

Reviewers: [Signature] Level Date
Further Evaluation Required? Yes No

EAO
Reviewers: B. Perkins 4/23/03

Entropy III

Page 189/240

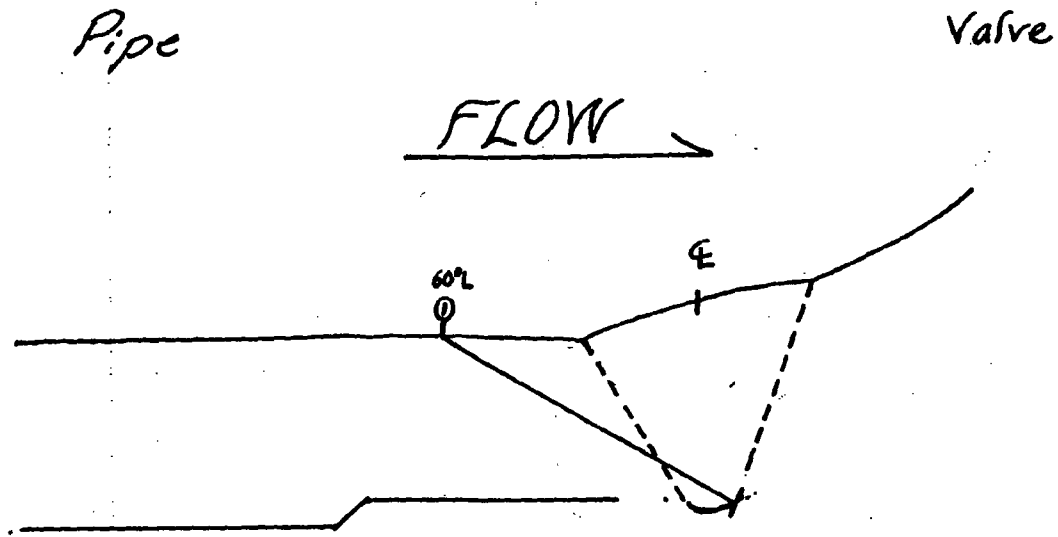

✓ reviewed original
radiographs and
root convexity present.
Supports plots.

13 Pustais III
4/22/03

Examiner *Paul T. Hayes*
Paul T. Hayes

Level II

Date 4/21/03

Page 11/240



Calibration Data Sheet

Figure 5

Plan/Unit Pilgrim 1
Company Scientech

Comp/System 10R-1A-7/RHR
Procedure No. 50.87
Rev/Chng. No. 2
Cal. Block No. P11-64
Cal. Block Temp 60° Therm S/N 12252
Size 1.8" Sch. 0.735 "T"

Ferritic Austenitic

Each Major CRT Div. = 3"/.3"

Cal. Direction: Axial Circ. Both

Scan Area: 1 to Weld
11 to Weld

CDS 03-C-137

LDS 03-L-123

Page 1 of 1

Cal. Checks	Time
Initial Calib.	<u>0817</u>
Initial Calib. Date	<u>4/22/03</u>
Intermediate	
Intermediate	
Final Calib.	<u>1155</u>
Final Calib. Date	<u>4/22/03</u>

Compliant

Type: Ultrage II

Batch: 00325

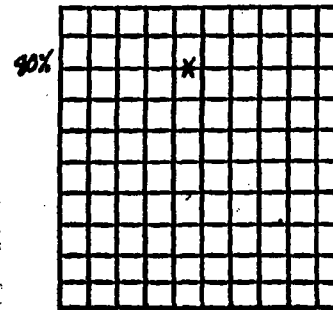

Search Unit #1

Manufacture: KBA
Serial No.: 00W80
Size: 0.50" Shape: Round
Freq: 1.5 MHz Style:
Exam Angle: 45° Mode: Shear
Measured Angle: 45°
Wedge Style: MSWQC

Search Unit Cable

Type: RG-174
Length: 6' No. 0

Instrument Settings

Make/Model: Staveland/Sonic 136
Serial No.: 850K
Delay: .458 Range: 3.0"
M'U Cal/Vel: .125 Pulser: 334us
Damping: 500Ω Reject: OFF
Rep. Rate: 4KHz Freq: 2.25
Filter: 1 Mode: P-E
Reference Sensitivity (Sens.)
Axial: 32.4 Circ: 32.4
SCAN SENS: 38.4

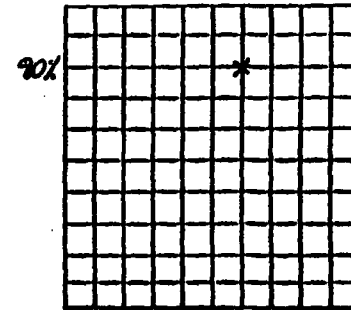

Search Unit #2

Manufacture: Megasonics
Serial No.: J1111
Size: 2(25X.50) Shape: rect
Freq: 2 MHz Style: CGD
Exam Angle: 60° Mode: Long
Measured Angle: 60°
Wedge Style: Integral

Search Unit Cable

Type: RG-174
Length: 6' No. 0

Instrument Settings

Make/Model: Staveland/Sonic 136
Serial No.: 850K
Delay: .430 Range: 3.0"
M'U Cal/Vel: .235 Pulser: 250
Damping: 500Ω Reject: OFF
Rep. Rate: 4KHz Freq: 2.25
Filter: 1 Mode: Dual
Reference Sensitivity (Sens.)
Axial: 70dB Circ: N/A
SCAN SENS: 70dB

Examination Area/Weld	Access	Recordable Indications			Exam Sens.
		Yes	No	Geom	
<u>10R-1A-7</u>	<u>DWST</u>	<u>X</u>		<u>X</u>	<u>38.4</u>
<u>10R-1A-7</u>	<u>DWST</u>	<u>X</u>		<u>X</u>	<u>70dB</u>

Remarks/Reason for Incomplete Scan(s)
① Single Sided exam due to component configuration (Valve to Pipe)
② Maintained 5-20% ID wall

Examiners: [Signature] Level II Date 4/22/03

Level _____ Date _____

Reviewers: B Perkins Further Evaluation Required? Yes No
Entropy III 4/23/03

Page 192/240

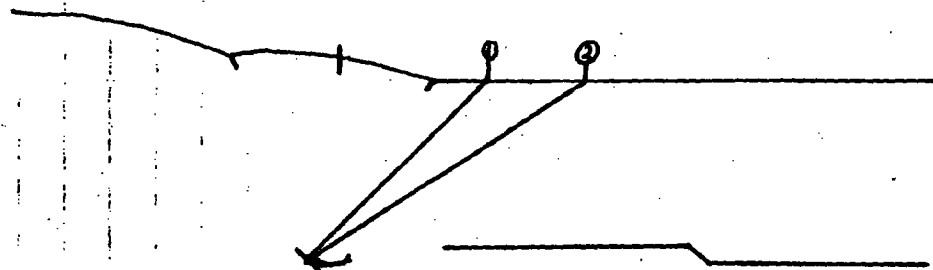

*also reviewed original
Radiographs of these
welds. Convex root pass
supports plots.

Examiner: ~~Paul T. Hayes~~ Level: II Date: 4/23/03
Paul T. Hayes

B. Puckner
NDE III
4/23/03

Boq 194/248

PRO



Calibration Data Sheet

Figure 5

Plant/Unit PNPS

Company ENERGY

Comp/System RWCU

Procedure No. II 50.87

Rev/Clng. No. 0

Cal. Block No. PIL-8A

Cal. Block Temp. 14 TSW Therm S/N

Size 6" Sch. "T"

Ferritic Austenitic

Each Major CRT Div. = .2"/.25"

Cal. Direction: Axial Circ. Both

Scan Area: I to Weld

II to Weld

L.D.S. No. 01-L-199

C. Data Sheet # 01-C-316

Page 1 of 1

Cal. Checks	Time
Initial Calib.	<u>1035/1146</u>
Initial Calib. Date	<u>5-4-01</u>
Intermediate	<u>N/A</u>
Intermediate	<u>N/A</u>
Final Calib.	<u>1800/1804</u>
Final Calib. Date	<u>5-4-01</u>

Couplant

Type: ULTRAGEL II

Batch: 00325

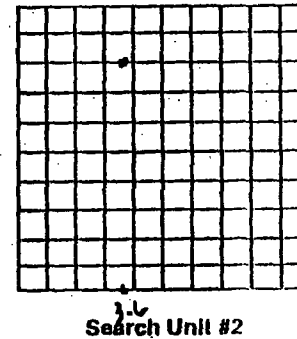
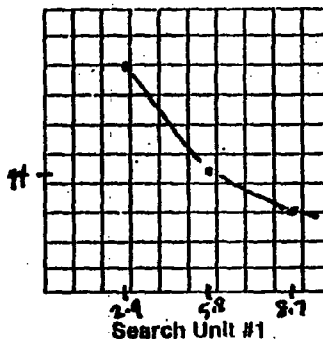

Manufacture: KGA

Serial No.: 008V60

Size: 375" Shape: Round

Freq: 2.25 MHz Style: Comp G

Exam Angle: 45° Mode: Shear

Measured Angle: 46°

Wedge Style: Non-Integral

Manufacture: KGA

Serial No.: 008V58

Size: 375" Shape: Round

Freq: 2.25 MHz Style: Comp G

Exam Angle: 70° Mode: Shear

Measured Angle: 67°

Wedge Style: Non-Integral

Examination Area/Weld	Access	Recordable Indications			Exam Sens.
		Yes	No	Geom	
<u>12-0-24 (45°)</u>	<u>DS</u>	<u>N/A</u>	<u>✓</u>	<u>N/A</u>	<u>49.0dB</u> <u>49.0dB</u>
<u>12-0-24 (70°)</u>	<u>DS</u>	<u>N/A</u>	<u>✓</u>	<u>N/A</u>	<u>53.2dB</u>
<u>N/A</u>	<u>N/A</u>				

Remarks/Reason for Incomplete Scan(s)
SINGLE SIDE SCAN DUE TO FLANGED HEAD TO PIPE CONFIGURATION.
56.64% COVERAGE
BP

Examiners: Dennis P. Thiel Level II Date 5-4-01

N/A Level N/A Date N/A

Reviewers: BP Further Evaluation Required? Yes No

NDT III

Search Unit Cable
Type: RG-174 U
Length: 6' No. 0

Search Unit Cable
Type: RG-174 U
Length: 6' No. 0

Instrument Settings

Make/Model: STAVELY/Sonic 136

Serial No.: 1009L

Delay: 0.329" Range: 2.0"

M'll Cal/Vol: 0.127% Pulsar: 222nS

Damping: 500n Reject: OFF

Rep. Rate: 4 kHz Freq: 2.25 MHz

Filter: 1 Mode: P-E

Reference Sensitivity (Sens.)
Axial: 37.0dB Circ: 37.0dB

SDH Sensitivity: 43.0dB/49.0dB

Instrument Settings

Make/Model: STAVELY/Sonic 136

Serial No.: 1009L

Delay: 0.469" Range: 2.5"

M'll Cal/Vol: 0.127% Pulsar: 222nS

Damping: 500n Reject: OFF

Rep. Rate: 4 kHz Freq: 2.25 MHz

Filter: 1 Mode: P-E

Reference Sensitivity (Sens.)
Axial: 53.2dB Circ: N/A

SDH Sensitivity: 53.2dB

Page 195/240

Instruction No. 50.87
Rev. 0
Page 24 of 27



Ultrasonic Examination Indication Report Sheet

Calibration Data Sheet Number: Φ1-C-316 EDS: Φ1-E-317 Lo Location: HEAD CENTER Start Time: 1520 Examiner: TC-1A-Level DENNIS P. STRICKLAND

Item Identification: 12-0-24 TEMP: 80°F Wo Location: WELD E Finish Time: 1600 Examiner: TC-1A-Level N/A

Component Information: Diameter (nom): 6" Thickness: .432" Procedure No. 50.87 Rev. 0 Date: 5-04-01 Weld Crown Width: .55"

Ind #	Angle Used	% of DAC	Indication Length			Max		OD S.U. Loc.	Scan Direction I II	Remarks
			L1	Max	L2	W	MP			
N/A	45°	—	—	—	N/A	—	—	—	LII	NO RECORDABLE INDICATIONS
N/A	70°	—	—	—	N/A	—	—	—	I	NO RECORDABLE INDICATIONS
N/A										

Additional Remarks: AMW V.17/20 DATE 5-5-01 COMPONENT MEETS / DOES NOT MEET ASME SECT. XI 1989

Reviewer(s): B. Peckin 5-5-01 Further Evaluation Required Yes — No X

Large 196/240

NOT III

Figure 6

WELD 12-0-24

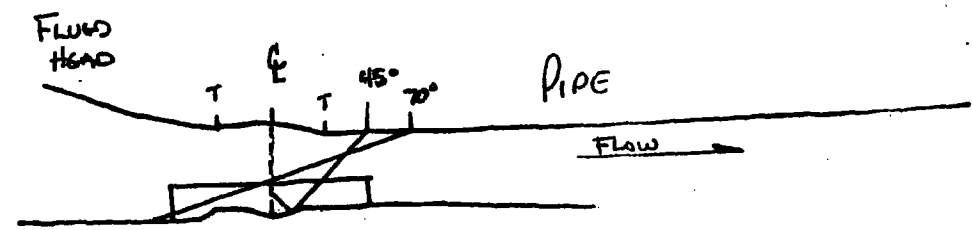

Dennis P. Strickland II 5-4-01
DENNIS P. STRICKLAND

TOTAL AREA = .1659"

SCANNED FROM:	59"	%: 05 54-01
(AX) DS	.12254"	76.56% 76.56%
(AX) US	.0859"	50.00%
(CIRC) CW	.0859"	50.00%
(CIRC) CCW	.0859"	50.00%
		<u>226.56%</u>
226.56% ÷ 4 (SCAN DIRECTIONS) =		56.64%
TOTAL COVERAGE =		56.64%

Page 197/240

Entergy

Calibration Data Sheet

CDS No: 05-C-437-151
LDS No: 05-L-422-151
Page: 1 of 1

Plant/Unit: PILGRIM
System: LORE SPRAY
Component: 14-A-19
Line No.: 10-DC-14
Procedure: ENHANC-923 Rev.: 0
Thermometer S/N: 230
Cal. Blk Temp.: 64° Comp Temp.: 67°
Cal. Block No.: PIL 8A
 Carbon Steel Stainless Steel
Size: 10.0" Sch.: .593 THK

Work Order: 03116643
DWG No.: ISI I 14-1

Cal Checks	Time
Initial Cal.:	<u>850 / 910</u>
Date:	<u>4-29-05</u>
Inter. Cal.:	
Date:	
Inter. Cal.:	
Date:	
Final Cal.:	<u>1645</u>
Date:	<u>4-29-05</u>

Cal Direction Axial Circ Both
Scan Area \perp to weld
Scan Area \parallel to weld

Couplant
Type: ULTRAGEL II
Batch: 01225

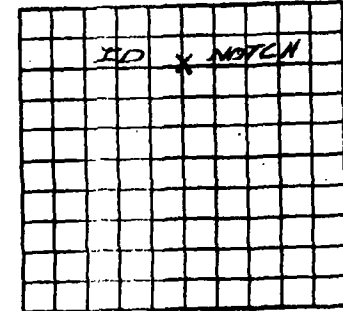
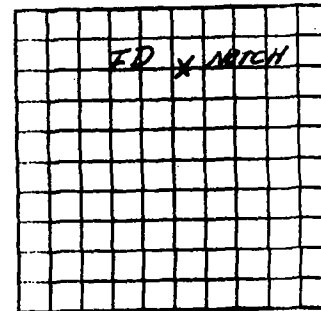

Search Unit # 1
Manufacturer: KRA
Model: COMP 6
Serial No.: 0075C4
Size: .575 Shape: RAND
Freq.: 1.5 # Elm: 1
Angle: 45° Mode: SHEAR
Measured Angle: 45°
Wedge Style: MSWGL

Search Unit # 2
Manufacturer: KRA-RTD
Model: COMP 6 TRLA
Serial No.: 00-728
Size: (2) 8xH Shape: SG
Freq.: 2.0 # Elm: 2
Angle: 70° Mode: LONG.
Measured Angle: 70°
Wedge Style: WHEEL

Search Unit Cable
Type: R6-174
Length: 6' # Con.: 0

Search Unit Cable
Type: (2) R6-174
Length: 6' # Con.: 0

Instrument Settings
Manufacturer: STAVLEY
Model: Sonic 136
Serial No.: 06P12004041457
Linearity Due: 6-2-05
Delay: .283 Range: 2.00
Mtl. Vel.: .123 Pulsar: 354
Damping: 500 Reject: OFF
Rep Rate: 4K Freq.: 2.25
Filter: 2 Mode: PE

Instrument Settings
Manufacturer: STAVLEY
Model: Sonic 136
Serial No.: 136P12004041457
Linearity Due: 5-2-05
Delay: .943 Range: 4.0
Mtl. Vel.: .230 Pulsar: 250
Damping: 500 Reject: DEF
Rep Rate: 4K Freq.: 2.25
Filter: 2 Mode: DUAL

Examination Area / Weld	Access	Recordable Indications			Exam Sens.
		Yes	No	Geom.	
<u>14-A-19</u>	<u>SINGLE</u>		<input checked="" type="checkbox"/>		<u>39.0</u>

Remarks
Further Evaluation Required: Yes No

Examiner: D. T. Conroy on board Level: II Date: 4-29-05
Examiner: N/A Level: N/A Date: N/A
Reviewer: W. J. ... Level: III Date: 4/30/05
ANII: Carl ... Date: 4/30

Reference Sensitivity
Axial: 33.0 Circ: 33.0

Reference Sensitivity
Axial: 68.6 Circ: N/A

Page 108/240



Examination Data Sheet

EDS No: 05-E-458-151
 CDS No: 05-C-457-151
 LDS No: 05-L-422-151
 Page: _____ of _____

Plant/Unit: <i>PILGRIM</i>		System: <i>CORE SPRAY</i>		Component: <i>VALVE TO PIPE</i> <i>14-A-19</i>		Procedure: <i>ENI-NDE-923</i>					
Work Order: <i>03116643</i>		DWG No.: <i>ISI I 14-1</i>		<input type="checkbox"/> Carbon Steel <input checked="" type="checkbox"/> Stainless Steel		Start Time/Date: <i>1510 4-29-05</i> Finish Time/Date: <i>1540 4-29-05</i>					
Examination Area / Weld No.: <i>14-A-19</i>		Line No.: <i>10-DC-14</i>		Size: <i>10"</i> Schedule: <i>.593 THK.</i>		Lo Location: <i>T.D.C.</i> Wo Location: <i>WELD 9</i>					
Ind. #	Angle	% of DAC	Indication Length			Max Location		OD SU Loc.	Scan Direct.	Remarks:	
			L1	L Max	L2	W	MP				
										<i>NO RECORDABLE INDICATIONS</i>	
Further Evaluation Required: <input type="checkbox"/> Yes <input checked="" type="checkbox"/> No				Limitations: <i>VALVE</i>							
Remarks											
Examiner: <i>DJ-1</i> Level: <i>II</i> Date: <i>4-29-05</i>				Examiner: <i>M/A</i> Level: <i>7/2</i> Date: <i>4/29</i>							
Reviewer: <i>W. H. Johnson</i> Level: <i>III</i> Date: <i>4/30/05</i>				ANII: <i>Carl Johnson</i> Date: <i>5/1/05</i>							

Page 197/240



Sketch Sheet

Data Sheet No: 05-E-458-151

Page: 2 of 2

Plant/Unit: <u>PILGRIM</u>	System: <u>CORE SPRAY</u>	Component: <u>14-A-19</u>	Procedure: <u>ENN-NDE - 9.23</u> Revision: <u>0</u>
Examination Area / Weld No.: <u>14-A-19</u>	DWG No.: <u>ISI I 14-1</u>	Line No.: <u>10-DL-14</u>	Work Order: <u>03116643</u> <u>ISI I 14-1 DWG NO.</u>

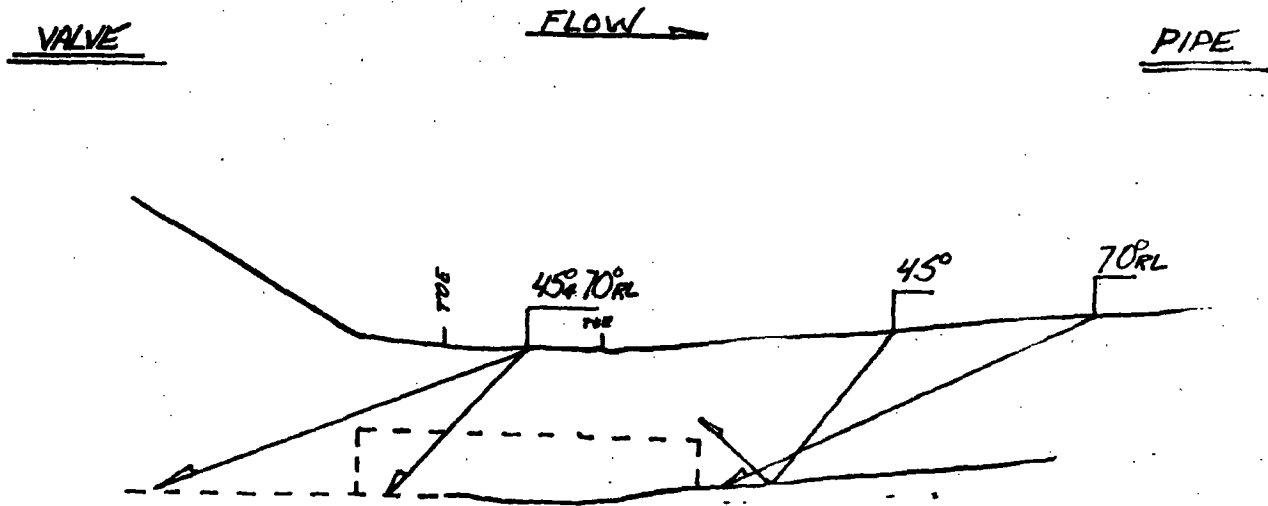

50% CRV. DUE TO SINGLE SIDE EXAM
AS PER ENN-NDE - 9.23 REV. 0 PAR. 1.8

Examiner: [Signature] Level: II Date: 4-29-05

Examiner: [Signature] Level: II Date: 4/29

Reviewer: [Signature] Level: III Date: 4/30/05

ANII: [Signature] Date: 5/4/05

Page 200/240



Calibration Data Sheet

Figure 5

Plan/Unit PNPS
 Company ENERGY
 Comp/System CORG SPRAY
 Procedure No. ITI 50.87
 Rev/Chng. No. 0
 Cal. Block No. PIL-8A
 Cal. Block Temp. 62.1766 Therm S/N
 Size 10" Sch. .513" T
 Ferritic Austenitic
 Each Major CRT Div. = .25"
 Cal. Direction: Axial Circ. Dolt
 Scan Area:

CDS 01-C-193
 LDS 01-L-141

Cal. Checks	Time
Initial Calib.	<u>0830/1015</u>
Initial Calib. Date	<u>4-26-01</u>
Intermediate	<u>N/A</u>
Intermediate	<u>N/A</u>
Final Calib.	<u>1553/1554</u>
Final Calib. Date	<u>4-26-01</u>

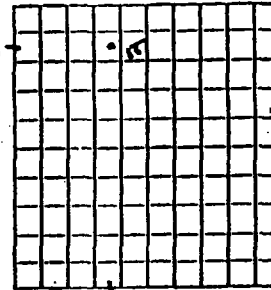

Search Unit #1

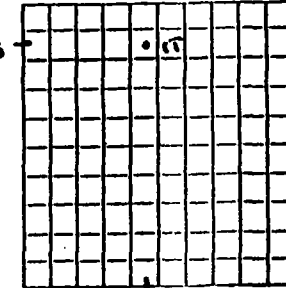

Search Unit #2

Manufacturer: KBA
 Serial No.: 00804R
 Size: .375" Shape: ROUND
 Freq: 1.5 MHz Style: LONG G
 Exam Angle: 45° Mode: SEMI
 Measured Angle: 48°
 Wedge Style: NON-INTEGRAL

Manufacturer: MEGASONIC
 Serial No.: J1121
 Size: (2.25" x 2.20") Shape: RECT.
 Freq: 2 MHz Style: CGD
 Exam Angle: 60° Mode: LONG
 Measured Angle: 58.9°
 Wedge Style: INTEGRAL

Search Unit Cable
 Type: RG-174V
 Length: 6' No. 0

Search Unit Cable
 Type: RG-174V
 Length: 6' No. 0

Instrument Settings
 Make/Model: SMARLEY/Sonic 136
 Serial No.: 1009L
 Delay: 0.323" Range: 2.5"
 M'II Cal/Vol: 0.25% Pulsar: 334uS
 Damping: 500u Reject: OFF
 Rep. Rate: 4 KHz Freq: 2.25 MHz
 Filter: 2 Mode: P/E
 Reference Sensitivity (Sens.)
 Axial: 35.2dB Circ: 35.2dB
 SCAN SENS.: 47.2dB/47.2dB

Instrument Settings
 Make/Model: SMARLEY/Sonic 136
 Serial No.: 1009L
 Delay: 0.614" Range: 2.5"
 M'II Cal/Vol: 0.232% Pulsar: 250uS
 Damping: 500u Reject: OFF
 Rep. Rate: 4 KHz Freq: 2.25 MHz
 Filter: 2 Mode: DUP
 Reference Sensitivity (Sens.)
 Axial: 61.0dB Circ: N/A
 SCAN SENS.: 67dB

Examination Area/Weld	Access	Recordable Indications			Exam Sens.
		Yes	No	Geom	
<u>14-B-17</u>	<u>US</u>	<u>N/A</u>	<u>✓</u>	<u>N/A</u>	<u>47.2</u> <u>67.0</u>
<u>14-B-20</u>	<u>US</u>	<u>N/A</u>	<u>✓</u>	<u>N/A</u>	<u>47.2</u> <u>67.0</u>
	<u>N</u>				
	<u>A</u>				

Remarks/Reason for Incomplete Scan(s)
SEE ATTACHED COVERAGE PLOTS

Examiners: [Signature] Level II Date 4/26/01
[Signature] Level III Date 4/26/01
 Reviewers: [Signature] Further Evaluation Required? Yes No

Page 201/240

Instruction No. 50.71
Rev. 5
Attachment A
Page 23 of 26



Ultrasonic Examination Indication Report Sheet

EDS No: <u>01-E-194</u>	CDS No: <u>01-C-193</u>	Lo Location: <u>TOP DECK GRD</u>	Start Time: <u>1250</u>	Examiner: TC-1A-Level <u>II</u> <u>Dennis P. Strickland</u>
Item Identification: <u>14-B-20</u>	TEMP: <u>80°F</u>	Wo Location: <u>Weld 4</u>	Finish Time: <u>1330</u>	Examiner: TC-1A-Level <u>Dale Murchio, III</u>
Component Information: Diameter(nom): <u>10"</u> Thickness: <u>.593"</u>		Procedure No.: <u>177 50.87</u>	Rev.: <u>0</u>	Date: <u>4-26-01</u> Weld Crown Width: <u>.8"</u>

Ind #	Angle Used	% of DAC	Indication Length			Max		OD S.U. Loc.	Scan Direction I II	Remarks
			L1	Max	L2	W	MP			
N/A	45°	—	—	—	N/A	—	—	—	I II	NO RECORDABLE INDICATIONS
N/A	60° RL	—	—	—	N/A	—	—	—	I	NO RECORDABLE INDICATIONS
N/A										

Page 202/240

ANII: [Signature] Date 4-28-01
 Reviewer(s) [Signature] Date 4/27/01 Reviewer(s) [Signature] Date 4/28/01
 Component Meets, Does Not Meet
 ASME Section XI 1989
 Further Evaluation Required Yes No

Figure 6



Ultrasonic Examination Indication Report Sheet

Page 2 of 4

EDS No: <u>Q1-E-194</u>	CDS No: <u>Q1-C-193</u>	Lo Location: <u>For Dean Case</u>	Start Time: <u>1450</u>	Examiner: TC-1A-Level II <u>Dennis P. Strickland</u>
Item Identification: <u>14-B-17</u>	TEMP: <u>80°F</u>	Wo Location: <u>Weld E</u>	Finish Time: <u>1530</u>	Examiner: TC-1A-Level <u>Dale M. ...</u>
Component Information: Diameter(nom): <u>10"</u> Thickness: <u>.593"</u>		Procedure No.: <u>171 50.87</u>	Rev.: <u>0</u>	Date: <u>4-26-01</u> Weld Crown Width: <u>.6"</u>

Ind #	Angle Used	% of DAC	Indication Length			Max		OD S.U. Loc.	Scan Direction I II	Remarks
			L1	Max	L2	W	MP			
N/A	45°				N/A				I II	NO RECORDABLE INDICATIONS
N/A	60° RL				N/A				I	NO RECORDABLE INDICATIONS
N/A										

ANII: [Signature] Date 4-28-01
 Reviewer(s) [Signature] Date 4/27/01 Reviewer(s) B. P. ... Date 4/26/01
 Component Meets, Does Not Meet
 ASME Section XI 1989
 Further Evaluation Required Yes No

Figure 6

Page 203/240

Instruction No. 50.87
Rev. 0
Page 25 of 27

CDS Ø1-C-193
 LDS Ø1-L-141

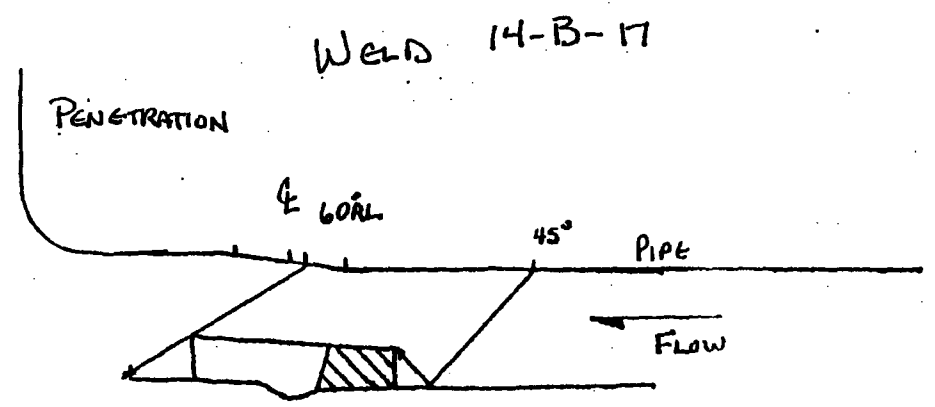

Dennis P. Strickland Date: 4-26-01
 DENNIS P. STRICKLAND

Total Area = .23 sq"

SCANNING Form :	Sq":	% :
(Ax) DS SIDE	.08 "	34.82 %
(Ax) US SIDE	.29 "	100.00 %
(Circ) CW SCANS	.145 sq"	50.00 %
(Circ) CCW SCANS	.145 sq"	50.00 %
		<u>234.82 %</u>

(Scan Directions) $\frac{234.82\%}{4} = 58.7\%$ TOTAL COVERAGE

Page 204/240

PAGE 4 4
 CDS 01-C-193
 LDS 01-L-141

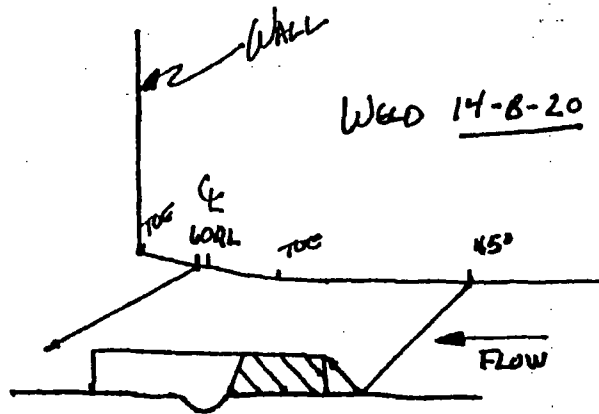

TOTAL AREA = .26 sq"

SCANNED FROM :	Sq" :	% :
(AX) DS SIDE	.09859"	37.69%
(AX) US SIDE	.269"	100.00%
(Circ) CW SCANS	.1359"	50.00%
(Circ) CCW SCANS	.1359"	50.00%
		<u>237.69%</u>
$\frac{237.69\%}{4 \text{ (SCAN DIRECTIONS)}} = 59.42\%$		TOTAL COVERAGE

Dennis P. Strickland JR 4-26-01
 DENNIS P. STRICKLAND

Bag 005/240



Calibration Data Sheet

Figure 5

Plan/Unit PNPS
 Company ENERGY
 Comp/System MAIN STEAM
 Procedure No. ITI 50.71
 Rev/Chng. No. 5
 Cal. Block No PIL-117
 Cal. Block Temp. 66°F Therm S/N
 Size 3" Sch. .438" T
 Ferritic Austenitic
 Each Major CRT Div. = .25"
 Cal. Direction: Axial Circ. Both
 Scan Area: 1 to Weld
11 to Weld

CDS 01-C-252
 LDS 01-L-199

Cal. Checks	Time
Initial Calib.	0824/0837
Initial Calib. Date	05-01-01
Intermediate	N
Intermediate	A
Final Calib.	1507/1536
Final Calib. Date	05-01-01

Couplant

Type: ULTRAGEL II
 Batch: 00325

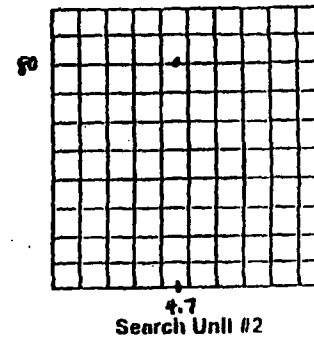
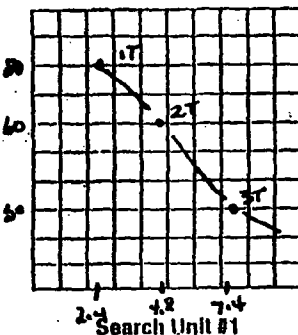

Manufacture: KBA
 Serial No.: 006N3L
 Size: .25" Shape: ROUND
 Freq: 5.0MHz Style: Comp G
 Exam Angle: 45° Mode: SITING
 Measured Angle: 45°
 Wedge Style: NON-INTEGRAL

Manufacture: KBA
 Serial No.: 006YWK
 Size: .25" Shape: ROUND
 Freq: 5.0MHz Style: Comp G
 Exam Angle: 70° Mode: SITING
 Measured Angle: 70°
 Wedge Style: NON-INTEGRAL

Search Unit Cable
 Type: RG-174U
 Length: 6' No. 0

Search Unit Cable
 Type: RG-174U
 Length: 6' No. 0

Instrument Settings
 Make/Model: STAVELY/SONIX 136
 Serial No: 1009L
 Delay: 0.236" Range: 2.5"
 M'I Cal/Vol: 0.130% Pulsar: POAS
 Damping: 500.0 Reject: OFF
 Rep. Rate: 4KHz Freq: 5.0MHz
 Filter: 2 Mode: P-E
 Reference Sensitivity (Sens.)
 Axial: 40.0dB Circ: 40.0dB
 SCAN SENS: 52.0dB/52.0dB

Instrument Settings
 Make/Model: STAVELY/SONIX 136
 Serial No: 1009L
 Delay: 0.399" Range: 2.5"
 M'I Cal/Vol: 0.131% Pulsar: 100AS
 Damping: 500.0 Reject: OFF
 Rep. Rate: 4KHz Freq: 5.0MHz
 Filter: 2 Mode: P-E
 Reference Sensitivity (Sens.)
 Axial: 68.0dB Circ: N/A
 SCAN SENS: 68.0dB

Examination Area/Weld	Access	Recordable Indications			Exam Sens.
		Yes	No	Geom	
1-SD-10R	US	N/A	✓	N/N	52.0dB 68.0dB
		N			
			A		

Remarks/Reason for Incomplete Scan(s)
SINGLE SIDED EXAM DUE TO PIPE TO VALVE CONFIGURATION.

Examiners: Dennis P. [Signature] Level II Date 05-01-01
[Signature] Level III Date 5/1/01
 Reviewers: B. [Signature] Further Evaluation Required? Yes No
MDT III

Page 206/240



Ultrasonic Examination Indication Report Sheet

CDS No: <i>PI-C-252</i>	EDS No: <i>PI-E-253</i>	Lo Location: <i>Top Deck Center</i>	Start Time: <i>1000</i>	Examiner: TC-IA-Level <i>Dennis P. Spickard II</i>
Item Identification: <i>1-5D-10R</i>	TEMP. <i>72°F</i>	Wa Location: <i>Weld</i>	Finish Time: <i>1100</i>	Examiner: TC-IA-Level <i>[Signature]</i>
Component Information: Diameter(nom): <i>3"</i> Thickness: <i>.438"</i>		Procedure No. <i>ITI 50.71</i>	Rev. <i>5</i>	Date: <i>05-01-01</i> Weld Crown Width: <i>1.1"</i>

Ind #	Angle Used	% of DAC	Indication Length			Max		OD S.U. Loc.	Scan Direction J. II	Remarks
			L 1	Max	L 2	W	MP			
<i>N/A</i>	<i>45°</i>				<i>N/A</i>				<i>↓ II</i>	<i>No RECORDABLE INDICATIONS</i>
<i>N/A</i>	<i>70°</i>				<i>N/A</i>				<i>↓</i>	<i>No RECORDABLE INDICATIONS</i>
<i>N/A</i>										

ANI: *[Signature]* Date *5-3-01*

Reviewer(s) *N/A* Date *N/A* Reviewer(s) *[Signature]* Date *5/6/01*

Component Meets, Does Not Meet
 ASME Section XI 1989
 Further Evaluation Required Yes No

Page 207/240

Figure 6

Instruction No. 50.71
Rev. 5
Attachment A
Page 24 of 26

VMS 2 of 2
 EDS: 01-E-253

WELD 1-SD-10R

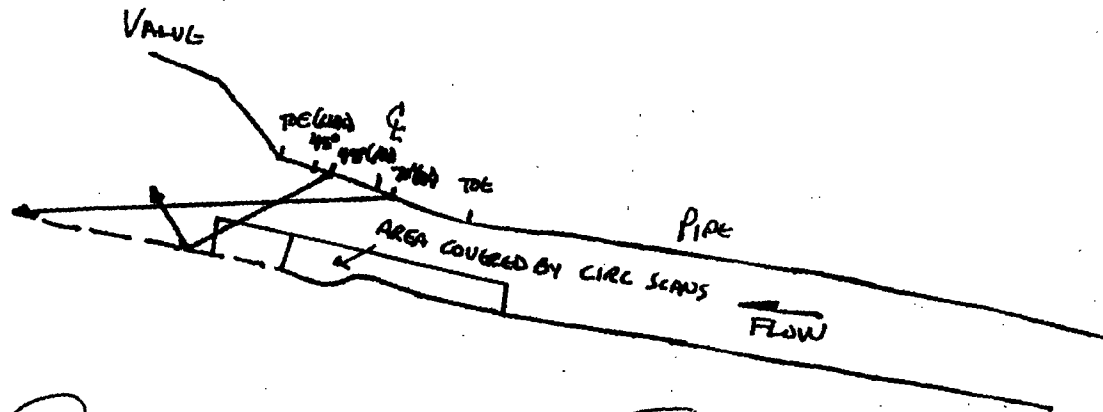

Dennis P. Hill II 5-01-01

TOTAL AREA .28 sq"		
SCAN FROM:	59"	0%
(Ax) DS SCAN	.28 sq"	100%
(Ax) US SCAN	.28 sq"	100%
(Circ) CCW SCANS	.245 sq"	75%
(Circ) CW SCANS	.245 sq"	75%
		<u>350%</u>

$350\% \div 4 \text{ (SCAN DIRECTIONS)} = 87.5\% \text{ TOTAL COVERAGE}$

Page 2 of 2



Calibration Data Sheet

Figure 5

Plant/Unit PNP 3
Company ENTERGY

LDS NO: 01-L-140
C. Data Sheet # 01-C-155
Page 1 of 2

Comp/System 2R-HB-1
Procedure No. TTI-5087
Rev/Chng. No. 0
Cal. Block No. P11-63
Cal. Block Temp. 72 Therm S/N
Size 12" Sch. 850" T

Ferritic Austenitic
Each Major CRT Div. = 45° 205/60° 288°
Cal. Direction: Axial Circ: Bolt
Scan Area  to Weld

Cal. Checks	Time
Initial Calib.	<u>1220</u>
Initial Calib. Date	<u>04/22/01</u>
Intermediate	<u>N</u>
Intermediate	<u>A</u>
Final Calib.	<u>1830</u>
Final Calib. Date	<u>04/22/01</u>

Couplant
Type: ULTRAGEL
Batch: 98325

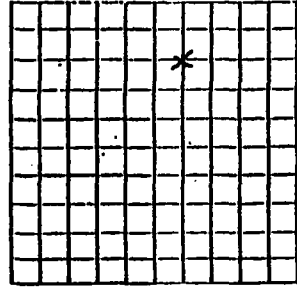

Search Unit #1
Manufacture: KBA
Serial No.: 0080LR
Size: 3.75 Shape: Round
Freq: 1.5MHz Style: M5600-Comp
Exam Angle: 45° Mode: SHEAR
Measured Angle: 44°
Wedge Style: NON-INTEGRAL

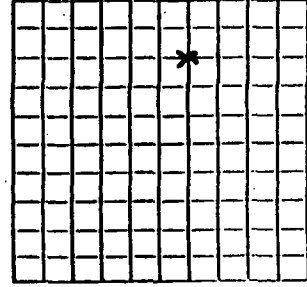

Search Unit #2
Manufacture: KBA
Serial No.: M15116
Size: .50" Shape: Round
Freq: 1.5" Style: M5600S
Exam Angle: 60° Mode: SHEAR
Measured Angle: 58°
Wedge Style: NON-INTEGRAL

Examination Area/Weld	Access	Recordable Indications			Exam Sens.
		Yes	No	Geom	
<u>2R-HB-1 45°</u>	<u>D/S</u>	<u>N/A</u>	<u>N/A</u>	<u>N/A</u>	<u>53.0</u>
<u>2R-HB-1 60°</u>	<u>D/S</u>	<u>N/A</u>	<u>N/A</u>	<u>N/A</u>	<u>62.6</u>

Remarks/Reason for Incomplete Scan(s)
ONE SIDED EXAM DUE TO REDUCER, D/S SIDE ONLY. TOTAL COVERAGE ACHIEVED IS 75%. SEE ATTACHED PLOT.

Examiners: [Signature] Level II Date 04/22/01
[Signature] Level II Date 4-22-01

Reviewers: [Signature] Further Evaluation Required? Yes No

Search Unit Cable
Type: BG-174
Length: 12' No. 1

Search Unit Cable
Type: BG-174
Length: 6' No. 1

Instrument Settings
Make/Model: STAVLEY/SUNC 136
Serial No: 1008L
Delay: 293 Range: 2.05
M'll Cal/Vel: 121 Pulsar: 334
Damping: 5000 Reject: OFF
Rep. Rate: 4K Freq: 2.25
Filter: 1 Mode: PIE
Reference Sensitivity (Sens.)
Axial: 41.0 Circ: 41.0
SDH Sensitivity: N/A

Instrument Settings
Make/Model: STAVLEY/SUNC 136
Serial No: 1008L
Delay: 274 Range: 2.88"
M'll Cal/Vel: 121 Pulsar: 334
Damping: 5000 Reject: OFF
Rep. Rate: 4K Freq: 2.25
Filter: 1 Mode: PE
Reference Sensitivity (Sens.)
Axial: 56.6 Circ: 56.6
SDH Sensitivity: N/A

Page 209/240



Ultrasonic Examination Indication Report Sheet

EDS No: Ø1-E-156	CDS No: Ø1-C-155	Lo Location: TDC	Start Time: 1500	Examiner: TC-1A-Level AMY E. KRAUSER / Amy E. Krauser
Item Identification: 2R-HB-1	TEMP: 82°	Wo Location: CENTERLINE	Finish Time: 1545	Examiner: TC-1A-Level SHANE CHARBONNET
Component Information: HEADER TO BEND (Ø2" x 12")		Procedure No.: ITI 50.87	Rev.: 0	Date: 4/22/01
Diameter (nom): 12"	Thickness: .8"			Weld Crown Width: .75"

Ind #	Angle Used	% of DAC	Indication Length			Max		OD S.U. Loc.	Scan Direction	Remarks
			L1	Max	L2	W'	MP			
1	60°	100%	0	1.0"	360°	.9"	1.58	D/S	L	ID GEOMETRY SEEN 360° - INTERMITTENT AT VARIOUS LOWER AMPLITUDES
N/A	45°								L/II	NO RECORDABLE INDICATIONS
N/A	60° RL								L	NO RECORDABLE INDICATIONS
				N						
					A					

ANII: Date 4-25-01

Reviewer(s) Date 4/24/01 Reviewer(s) B.P. Date 4/24/01

Component Meets, Does Not Meet
 ASME Section XI 1989
 Further Evaluation Required Yes No

Figure 6

Page 211/240

COMPONENT
2R-HB-1

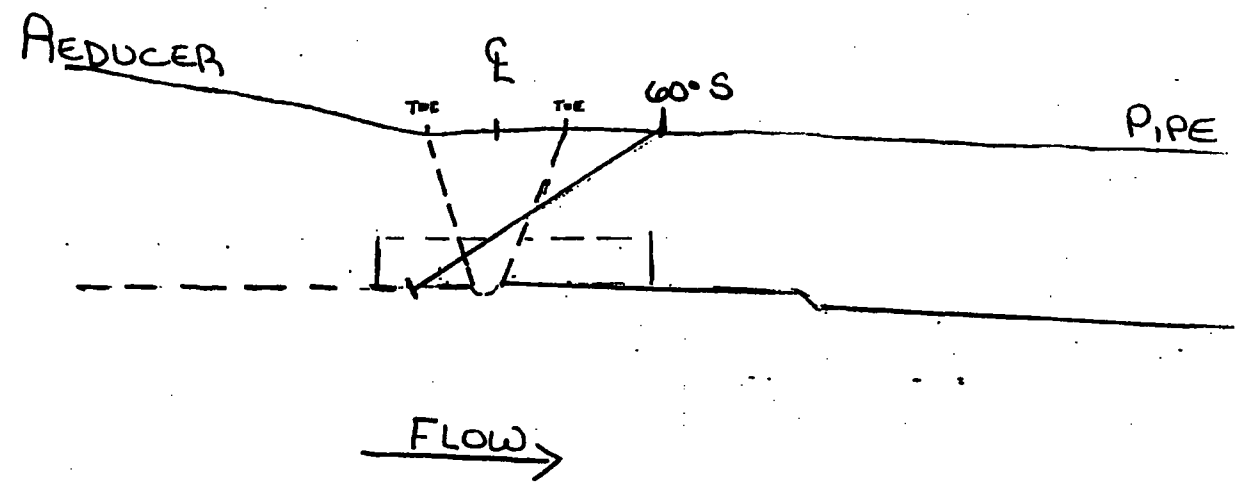

Req. 212/240

Amy E Krauser LVII
04/22/01
[Signature] LVII
4-22-01

EDS# 01 156
P9 373

COMPONENT
2R-HB-1

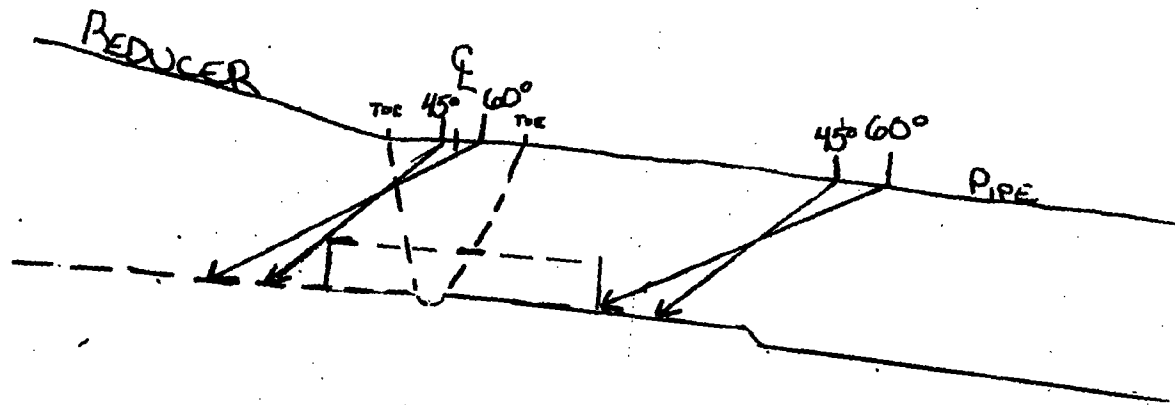

FLOW →

COVERAGE
SCAN 1 - AXIAL UPSTREAM = 0%
SCAN 2 AXIAL DOWNSTREAM = 100%
SCAN 3 CIRC CLOCKWISE = 100%
SCAN 4 CIRC COUNTERCLOCKWISE = 100%

Amy C Krauser W II
04/22/01

[Signature] W II
4-22-01

Page 2/3/240



Calibration Data Sheet

Figure 5

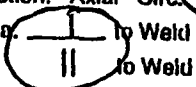
Plant/Unit PWP3
 Company ENERGY
 Comp/System 2R-HB-4
 Procedure No. TTI-5087
 Rev/Chng. No. 0
 Cal. Block No. P11-63
 Cal. Block Temp. 72 Therm S/N
 Size 12" Sch. 850 "T"
 Ferritic Austenitic
 Each Major CRT Div. = 45° 205 60° 288
 Cal. Direction: Axial Circ. Bolt
 Scan Area:  to Weld

LDS No: 01-L-140
 C. Data Sheet # 01-C-157
 Page 1 of 2

Cal. Checks	Time
Initial Calib.	1220
Initial Calib. Date	04/22/01
Intermediate	N/A
Intermediate	A
Final Calib.	1830
Final Calib. Date	04/22/01

Couplant
 Type: ULTRAGE1
 Batch: 98325

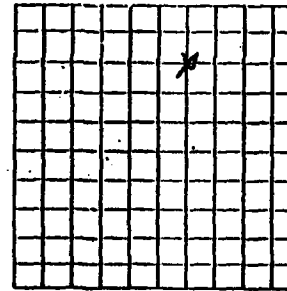

ID
 Search Unit #1

Manufacture: KBA
 Serial No.: 0080LR
 Size: .375 Shape: ROUND
 Freq: 1.5MHz Style: Misc Comp
 Exam Angle: 35° Mode: SHEAR
 Measured Angle: 44°
 Wedge Style: NON-INTEGRAL

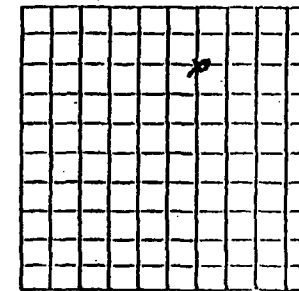

ID
 Search Unit #2

Manufacture: KBA
 Serial No.: M15116
 Size: .50" Shape: ROUND
 Freq: 1.5" Style: MISC
 Exam Angle: 60° Mode: SHEAR
 Measured Angle: 58°
 Wedge Style: NON-INTEGRAL

Search Unit Cable
 Type: BG-174
 Length: 12' No. 1

Search Unit Cable
 Type: BG-174
 Length: 6' No. 1

Instrument Settings
 Make/Model: STANLEY/Sonic 136
 Serial No: 1008L
 Delay: .293 Range: 2.05
 M'll Cal/Vel: .121 Pulsor: 334
 Damping: 500 Reject: OFF
 Rep. Rate: 4K Freq: 2.25
 Filter: 1 Mode: PIE
 Reference Sensitivity (Sens.)
 Axial: 41.0 Circ: 41.0
 SDH Sensitivity: N/A

Instrument Settings
 Make/Model: STANLEY/Sonic 136
 Serial No: 1008L
 Delay: .274 Range: 2.88"
 M'll Cal/Vel: .121 Pulsor: 334
 Damping: 500 Reject: OFF
 Rep. Rate: 4K Freq: 2.25
 Filter: 1 Mode: PE
 Reference Sensitivity (Sens.)
 Axial: 56.6 Circ: 56.6
 SDH Sensitivity: N/A

Examination Area/Weld	Access	Recordable Indications			Exam Sens.
		Yes	No	Geom	
2R-HB-4 45°	D/S	N/A	X	N/A	530
2R-HB-4 60°	D/S	N/A	X	N/A	626

Remarks/Reason for Incomplete Scan(s)
ONE SIDED EXAM DUE TO REDUCER. SCANNED D/S ONLY. TOTAL COVERAGE ACHIEVED IS 75%. SEE ATTACHED PLOT

Examiners: Tommy E. Kramer Level II Date 04/22/01
Jim H.A. Level II Date 4-22-01
 Reviewers: B. Parker Further Evaluation Required? Yes No
NOT III

Page 214/240

Calibration Data Sheet



Plant/Unit PNPS
 Company ENTERGY
 Comp/System 2B-HB-4
 Procedure No. ITI 50.87
 Rev/Chng. No. 0
 Cal. Block No. PL-63
 Cal. Block Temp. 72 MB99 (Therm) S/N
 Size 12" Sch. .850 "T"
 Ferritic Austenitic
 Each Major CRT Div. = .269
 Cal. Direction: Axial Circ. Both
 Scan Area  to Weld

LOS No: 01-L-140
 C. Data Sheet # 01-C-157
 Page 2 of 2

Cal. Checks	Time
Initial Calib.	<u>1225</u>
Initial Calib. Date	<u>04/22/01</u>
Intermediate	<u>N/A</u>
Intermediate	<u>N/A</u>
Final Calib.	<u>1830</u>
Final Calib. Date	<u>04/22/01</u>

Couplant
 Type: ULTRAGEL
 Batch: 98325

Examination Area/Weld	Access	Recordable Indications			Exam Sens.
		Yes	No	Geom	
<u>2B-HB-4</u>	<u>D/S</u>	<u>N/A</u>	<u>X</u>	<u>N/A</u>	<u>71.2</u>

Remarks/Reason for Incomplete Scan(s)
SCANNED AT REFERENCE SENSITIVITY, MAINTAINING 20% ID ROLL

Examiners: Amy E. Krause Level II Date 04/22/01
[Signature] Level II Date 4-22-01
 Reviewers: B. P. [Signature] Further Evaluation Required? Yes No
NOT III

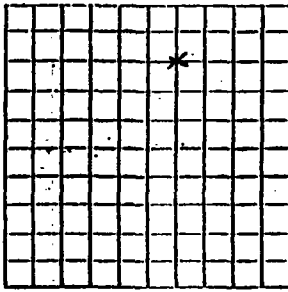

Search Unit #1

Manufacture: SIGMA
 Serial No.: 22AF9001
 Size: 2(14x8) Shape: RECT.
 Freq: 2MHz Style: SDA
 Exam Angle: 60° Mode: LONG
 Measured Angle: 59°
 Wedge Style: INTEGRAL

Search Unit Cable
 Type: BOX/IMO
 Length: 6' No. 2

Instrument Settings
 Make/Model: STAVELAND/SONIC
 Serial No.: 1008L
 Delay: 848 Range: 2.69°
 M'll Cal/Vol: 233 Pulsar: 250
 Damping: 500 Reject: OFF
 Rep. Rate: 4K Freq: 225
 Filter: 2 Mode: PE
 Reference Sensitivity (Sens.)
 Axial: 71.2 Circ: 71.2
 SDH Sensitivity: N/A

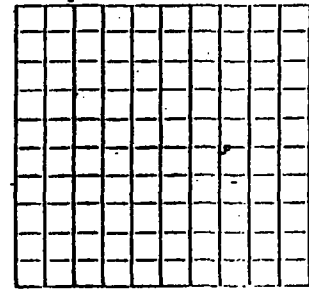

Search Unit #2

Manufacture: _____
 Serial No.: _____
 Size: _____ Shape: _____
 Freq: _____ Style: _____
 Exam Angle: _____ Mode: _____
 Measured Angle: _____
 Wedge Style: _____

Search Unit Cable
 Type: _____
 Length: _____ No. _____

Instrument Settings
 Make/Model: _____
 Serial No.: _____
 Delay: _____ Range: _____
 M'll Cal/Vol: _____ Pulsar: _____
 Damping: _____ Reject: _____
 Rep. Rate: _____ Freq: _____
 Filter: _____ Mode: _____
 Reference Sensitivity (Sens.)
 Axial: _____ Circ: _____
 SDH Sensitivity: _____

Page 215/240



Ultrasonic Examination Indication Report Sheet

EDS No: <u>01-E-158</u>	CDS No: <u>01-C-157</u>	Lo Location: <u>TDC</u>	Start Time: <u>1420</u>	Examiner: TC-1A-Level <u>AMUE WADYAR</u>
Item Identification: <u>2R-HB-4</u>	TEMP: <u>82°</u>	Wo Location: <u>CENTERLINE</u>	Finish Time: <u>1450</u>	Examiner: TC-1A-Level <u>SHANE CARBONET</u>
Component Information: <u>HEADER-BOND (90°/12°)</u>		Procedure No.: <u>ITI-50.87</u>	Rev.: <u>0</u>	Date: <u>4/22/01</u>
Diameter(nom): <u>12"</u>	Thickness: <u>0.8</u>			Weld Crown Width: <u>.75</u>

Ind #	Angle Used	% of DAC	Indication Length			Max		OD S.U. Loc.	Scan Direction I II	Remarks
			L1	Max	L2	W	MP			
<u>N/A</u>	<u>45°</u>							<u>I/II</u>	<u>NO RECORDABLE INDICATIONS</u>	
<u>N/A</u>	<u>60°</u>							<u>I</u>	<u>NO RECORDABLE INDICATIONS</u>	
<u>N/A</u>	<u>60° RL</u>							<u>I</u>	<u>NO RECORDABLE INDICATIONS</u>	

ANII: [Signature] Date 4-25-01
 Reviewer(s) [Signature] Date 4/24/01 Reviewer(s) [Signature] Date 4/29/01

Component Meets, Does Not Meet
 ASME Section XI 1989
 Further Evaluation Required Yes No

Page 216/240

Figure 6

COMPONENT
2R-HB-4

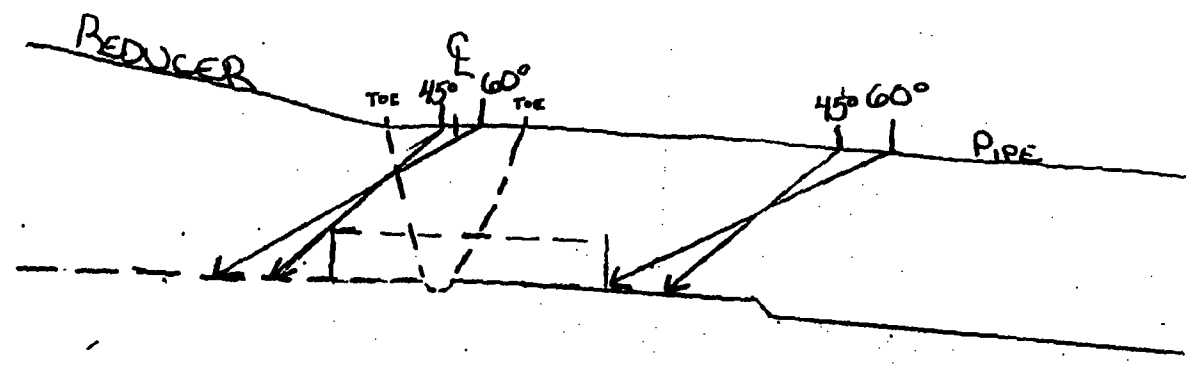

FLOW →

COVERAGE

- SCAN 1 AXIAL UPSTREAM = 0%
- SCAN 2 AXIAL DOWNSTREAM = 100%
- SCAN 3 CIRC CLOCKWISE = 100%
- SCAN 4 CIRC COUNTERCLOCKWISE = 100%

Log 217240

Amy Elkaner LVII
04/22/01

[Signature] LVII
4-22-01

ME01



Entergy

ENN
NUCLEAR
MANAGEMENT
MANUAL

QUALITY RELATED
NON-ADMINISTRATIVE PROCEDURE

INFORMATIONAL USE

ENN-NDE-9.41 Revision 0

Page 15 of 20

ATTACHMENT 9.4

LIQUID PENETRANT EXAMINATION REPORT

Page 1 of 1

<input type="checkbox"/> IP2	<input type="checkbox"/> IP3	<input type="checkbox"/> JAF	<input checked="" type="checkbox"/> PNPS	<input type="checkbox"/> VY	Report No: <u>05-P-432-151</u>
WORK AUTHORIZATION <u>03116627</u>	ISO/DWG <u>N/A</u>	COMPONENT/WELD/ITEM # <u>CRDM</u>		Procedure No: <u>ENN-NDE-9.41</u> REV. <u>0</u>	
MAT'L TYPE <input type="checkbox"/> CS <input checked="" type="checkbox"/> SS	TEMPERATURE EXAM SURF. <u>80°F</u>	TEMP. INST. # <u>208</u> DUE DATE <u>8-9-05</u>	SURFACE CONDITION <input checked="" type="checkbox"/> WELDED <input type="checkbox"/> GROUND <input type="checkbox"/> FORGED <input type="checkbox"/> COATED <input type="checkbox"/> MATE LOGGED <input type="checkbox"/> BRUSHED <input type="checkbox"/> MACHINED <input type="checkbox"/> SAND-BLASTED <input type="checkbox"/>		
TECHNIQUE <input checked="" type="checkbox"/> SOLVENT REMOVABLE <input type="checkbox"/> WATER WASHABLE					
METHOD <input checked="" type="checkbox"/> VISIBLE <input type="checkbox"/> FLUORESCENT		BLACK LIGHT MODEL <u>N/A</u> SN <u>N/A</u>	BLACK LIGHT METER: <u>N/A</u> CAL DUE DATE: <u>N/A</u>		
CLEANER Manufacturer: <u>SHERWIN</u> Type: <u>DOUBL CHEK DR-60</u> BATCH # <u>524641</u>		PENETRANT Manufacturer: <u>SHERWIN</u> Type: <u>DOUBL CHEK DP-40</u> BATCH # <u>B/N 517-E1</u>	DEVELOPER Manufacturer: <u>SHERWIN</u> Type: <u>DOUBL CHEK-D-100</u> BATCH # <u>A1988/ CB 8766</u>		
EXAMINATION RESULTS					
PART IDENTIFICATION	ACC	REJ	IND. CODE	REMARKS*	
<u>CRDM WELD - Loc 30-51</u>	<input checked="" type="checkbox"/>		<u>4</u>	<u>LIMITED TO 50% WELD AREA DUE TO ACCESSABILITY</u>	
<u>CRDM WELD - Loc 14-51</u>	<input checked="" type="checkbox"/>		<u>4</u>	<u>LIMITED TO 70% WELD AREA DUE TO ACCESSABILITY</u>	
ACCEPTANCE CRITERIA: <u>ASME SEC. XI</u> <u>LD 4-11.05</u>					
% COMPLETE: <u>SEE REMARKS</u>			LIMITATIONS: <u>SEE REMARKS</u>		
INDICATION CODE: 1: ROUNDED 2: LINEAR 3: NO INDICATIONS 4: NO RELEVANT INDICATIONS. 5: OTHER					
SKETCHES OR COMMENTS SKETCH-Indicate size, location, orientation, and distribution of indications. Provide dimensions on all sketches. Use additional sheets if required.					
EXAMINED BY/LEVEL/DATE <u>Douglas L Bockay 4-19-05</u>			EXAMINED BY/LEVEL/DATE <u>N/A</u>		
Company FINAL REVIEW LEVEL/DATE <u>CS Tahar Shum 111 4/26/05</u>			ANII REVIEW/DATE <u>Carl Hansen 5/8/05</u>		

* QA Category and ASME XI Class

Page 218 / 240

BOSTON EDISON COMPANY
 RECORD OF MAGNETIC PARTICLE EXAMINATION

DATA SHEET # *Pg 1 of 2*
 97-M-334

ITEM ID/PIECE # EB-23-13HL1 (4)	SYSTEM <u>d3</u> LOCATION <u>Torus</u>	MR # <u>19600295</u>	ISO/DWG NUMBER <u>ISI-I-23-2</u>	REV. <u>E4</u>
---	---	-------------------------	-------------------------------------	----------------

A. MATERIAL	TYPE <u>CS</u>
-------------	----------------

CROSS SECTION THICKNESS	MAX <u>VARIOUS</u>	MIN	GEOMETRY	PIPE	PLATE	ROD	OTHER <u>X LUG'S</u>
-------------------------	--------------------	-----	----------	------	-------	-----	----------------------

FABRICATION PROCESS	CAST	WORKED	<u>WELDED</u>	OTHER
---------------------	------	--------	---------------	-------

SURFACE	MACHINED	GROUND <u>AS FABRICATED</u>	OTHER	INSPECTION HOLD PT <u>FINAL MT</u>
---------	----------	-----------------------------	-------	---------------------------------------

SURFACE IS SUITABLE FOR SCHEDULED X MT $\frac{1}{2}$ UT EXAMINATION YES NO

SKETCH OR OTHER DETAIL ATTACHED <u>YES</u> NO	WEIGHT <u>X</u> 10 LB. <u>40</u> LB
---	-------------------------------------

B. PROCEDURE # VALIDATION # POLE SPACING	<u>QCI 50.20</u> <u>N.A</u> <u>4" TO 6"</u>	EQUIPMENT IDENTIFICATION <u>X</u> AC <u>HWAC</u> <u>5156</u>
--	---	--

C. EVALUATION

LOCATION	SIZE (INCHES)	DESCRIPTION	ACTION (ACCEPT, REWORK, REJECT AND COMMENT AS NECESSARY.)
1		<u>NO RECORDABLE INDICATIONS</u>	<u>ACCEPT AS LIMITED EXAMINATION</u>
2			<u>DUE TO HANGER CLAMP SEE</u>
3			<u>SKETCH</u>
4			
5			<u>CODE COVERAGE 87.5%</u>
6			
7			

D. CRITERIA	<u>ASME SECT XI 1989</u>
-------------	--------------------------

COMPONENTS MEET DO NOT MEET ASME SECTION XI ACCEPTANCE CRITERIA, FURTHER EVALUATION REQUIRED YES X NO

E. ATTEST	<u>C. Ellis</u> I R. <u>II</u> <u>3/18/97</u> RESPONSIBLE CERTIFIED PERSONNEL LEVEL DATE
	<u>B. Perkins</u> <u>3/19/97</u> <u>III</u> <u>3/19/97</u> RECO LEVEL DATE ANIA DATE

SKETCH SHEET

ITEM ID# EB-23-13HL1 (4)

MR# 19600295

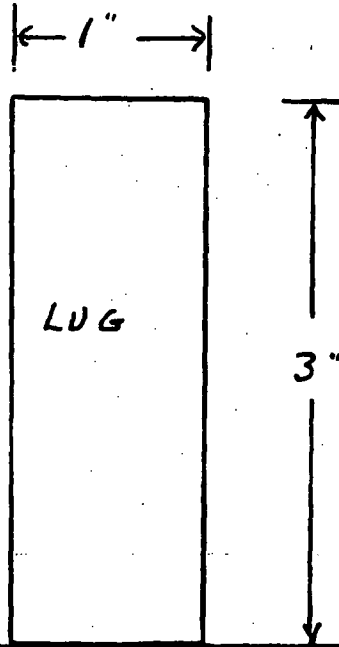

TYPICAL
1 of 4

HANGER CLAMP TYPICAL

LIMITED EXAM DUE TO HANGER CLAMP,
CODE COVERAGE 87.5%

CEP/AL A II 3-18-97

RECORD OF MAGNETIC PARTICLE EXAMINATION			DATA SHEET # <u>01-M-272</u>
ITEM ID/PIECE #	SYSTEM <u>(23) HPCI</u>	MR#	ISO/DWG NUMBER
<u>EB-23-59HL1 (4)</u>	LOCATION <u>HPCI Room</u> <u>ELV. 10'</u>	<u>10000542</u>	<u>151-1-23-2</u>
A. MATERIAL	TYPE <u>CARBON STEEL</u>		
CROSS SECTION THICKNESS	MAX <u>N/A</u>	MIN <u>N/A</u>	PIPE PLATE ROD OTHER GEOMETRY <u>N/A N/A N/A LUG TO PIPE WELDS</u>
FABRICATION PROCESS	CAST WORKED <u>WELDED</u> OTHER _____		
SURFACE	MACHINED GROUND AS OTHER <u>FABRICATED</u>	INSPECTION HOLD PT <u>1.5.1.</u>	
SURFACE IS SUITABLE FOR SCHEDULE <input checked="" type="checkbox"/> MT <input checked="" type="checkbox"/> UT EXAMINATION <input checked="" type="checkbox"/> YES <input type="checkbox"/> NO			
SKETCH OR OTHER DETAIL ATTACHED YES/NO <input type="checkbox"/> WEIGHT <input checked="" type="checkbox"/> 10 LB <input type="checkbox"/> 40 LB			
B. PROCEDURE # VALIDATION # POLE SPACING	<u>IT 50.20</u> <u>N/A</u> <u>6"</u>	EQUIPMENT IDENTIFICATION AC <input checked="" type="checkbox"/> HWAC <input type="checkbox"/> S/N <u>69</u>	
C. EVALUATION <u>N.R.I. OBTAINED 83.3% COVERAGE DUE TO LUG TO CLAMP CONFIGURATION.</u>			
LOCATION	SIZE (INCHES)	DESCRIPTION	ACTION (ACCEPT, REWORK, REJECT AND COMMENT AS NECESSARY)
1.			
2.			
3.			
4.		<u>N</u>	<u>A</u>
5.			
6.			
7.			
D. CRITERIA	COMPONENTS MEET/DO NOT MEET ASME SECTION XI CRITERIA FURTHER EVALUATION REQUIRED <input type="checkbox"/> YES <input checked="" type="checkbox"/> NO <u>ASME SECT. XI 1989</u>		
E. ATTEST	<u>[Signature]</u> RESPONSIBLE CERTIFIED PERSONNEL <u>[Signature]</u> NDT LEVEL III	<u>5/3/01</u> DATE	<u>5/3/01</u> DATE <u>[Signature]</u> LEVEL <u>[Signature]</u> ANII <u>5/4/01</u> DATE

B. Perkins 5/3/01
 ENERGY III DATE

BOSTON EDISON COMPANY
RECORD OF MAGNETIC PARTICLE EXAMINATION

DATA SHEET # *Page 1 of 2*
97-M-302

ITEM ID/PIECE # HL-10-200HL(4)	SYSTEM <u>10</u> LOCATION <u>R/R A quad</u>	MR # 19600301	ISO/DWG NUMBER ISI-I-10-4A-SH-1	Rev. E4
-----------------------------------	--	------------------	------------------------------------	------------

A. MATERIAL	TYPE <u>CS</u>
-------------	-------------------

CROSS SECTION THICKNESS	MAX <u>VARIOUS</u>	MIN	GEOMETRY	PIPE	PLATE	ROD	OTHER <u>X LUG'S</u>
-------------------------	-----------------------	-----	----------	------	-------	-----	-------------------------

FABRICATION PROCESS	CAST	WORKED	<u>WELDED</u>	OTHER
---------------------	------	--------	---------------	-------

SURFACE	MACHINED <u>GROUND</u>	AS FABRICATED	OTHER	INSPECTION HOLD PT <u>FINAL MT</u>
---------	------------------------	---------------	-------	---------------------------------------

SURFACE IS SUITABLE FOR SCHEDULED X MT ^{N/A} UT EXAMINATION. YES/NO

SKETCH OR OTHER DETAIL ATTACHED	<u>YES</u> /NO	WEIGHT	<u>X</u> 10 LB. <u>40</u> LB
---------------------------------	----------------	--------	------------------------------

B. PROCEDURE # VALIDATION # POLE SPACING	<u>QCI 50.20</u> <u>N-A</u> <u>4"-6"</u>	EQUIPMENT IDENTIFICATION <u>X</u> AC <u>HWAC</u> <u>5156</u>
--	--	--

C. EVALUATION	
---------------	--

NO.	LOCATION	SIZE (INCHES)	DESCRIPTION	ACTION (ACCEPT, REWORK, REJECT AND COMMENT AS NECESSARY.)
1			NO RECORDABLE INDICATIONS	LIMITED EXAMINATION: ACCEPT
2				(LIMITED ON UPSTREAM SIDE OF LUG'S BY HANGER CLAMP SEE SKETCH.)
3				
4				
5				CODE COVERAGE 90%
6				
7				

D. CRITERIA	<u>ASME Sect. II 1989</u>
-------------	---------------------------

COMPONENTS MEET / DO NOT MEET ASME SECTION XI ACCEPTANCE CRITERIA, FURTHER EVALUATION REQUIRED: YES X NO

E. ATTEST	<u>C. Pells</u> RESPONSIBLE CERTIFIED PERSONNEL GE REVIEWED BY: <u>M. Jones</u> LV III 3/14/97	<u>II</u> LEVEL	<u>3/14/97</u> DATE
	<u>B. Puckett</u> BECO LEVEL III	<u>3/14/97</u> DATE	<u>V. M. Hill</u> ANIL DATE <u>3/14/97</u>

SKETCH SHEET

ITEM ID # HL-10-200HL (4)

FOR DATA SHEET # 97-M-302
page 2 of 2

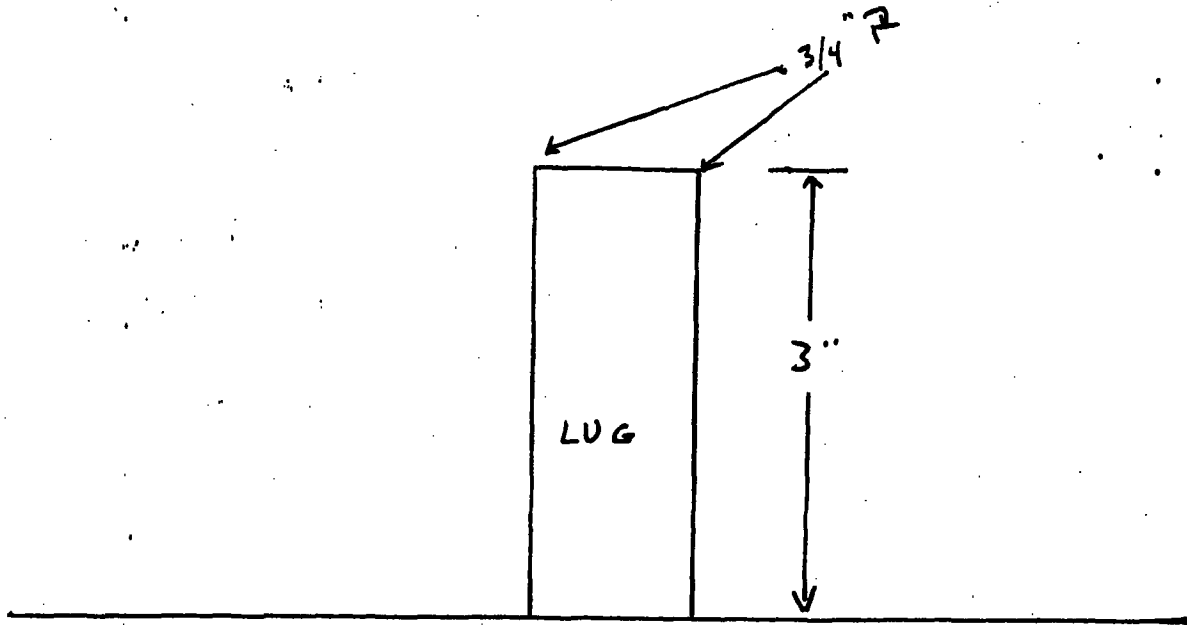

HANGER CLAMP

TYPICAL 1 of 4

CODE COVERAGE 90%



Calibration Data Sheet

CDS No: 05-C-377-151
 LDS No: 05-L-377-151 *7/15/05*
 Page: 4 of 4

Plant/Unit: PILGRIM / 1
 System: CORE SPRAY
 Component: GB-14-F34
 Line No.: 6" - GB-14
 Procedure: ENW-MDE-9.10 Rev.: 0
 Thermometer S/N: 232
 Cal. Blk Temp.: 63°F Comp Temp.: 64°F
 Cal. Block No.: PIL-96
 Carbon Steel Stainless Steel
 Size: 6" Sch.: .432"

Work Order: 03116642
 DWG No.: ISI I 14-2B

Cal Checks	Time
Initial Cal.:	<u>0945</u>
Date:	<u>4-25-05</u>
Inter. Cal.:	
Date:	
Inter. Cal.:	
Date:	
Final Cal.:	<u>1603</u>
Date:	<u>4-25-05</u>

Cal Direction Axial Circ Both
 Scan Area \perp to weld
 Scan Area \parallel to weld

Couplant
 Type: ULTRAGEL II
 Batch: 01225

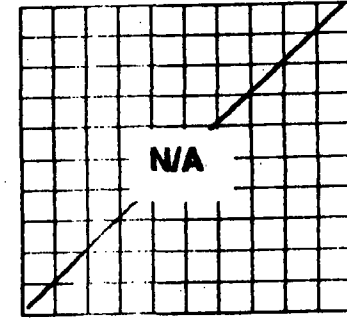
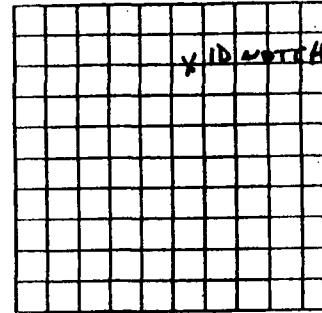

Search Unit # 1
 Manufacturer: RTD
 Model: TRLA
 Serial No.: 98-1082
 Size: 2(7x10) Shape: RECT
 Freq.: 2 MHz # Elm: 2
 Angle: 70° Mode: LONG
 Measured Angle: 71°
 Wedge Style: INTEGRAL

Search Unit # 2
 Manufacturer: _____
 Model: _____
 Serial No.: _____
 Size: _____ Shape: _____
 Freq.: _____ # Elm: _____
 Angle: _____ Mode: _____
 Measured Angle: _____
 Wedge Style: _____

Search Unit Cable
 Type: RG 174
 Length: 6' # Con.: 0

Search Unit Cable
 Type: _____
 Length: _____ # Con.: _____

Instrument Settings
 Manufacturer: STANLEY
 Model: SONIC 136
 Serial No.: 136-875K
 Linearity Due: 5-2-05
 Delay: .815 Range: 2.00
 Mtl. Vel.: .230 Pulser: 250
 Damping: 500 Reject: OFF
 Rep Rate: 4K Freq.: 2.25
 Filter: 2 Mode: DUAL

Instrument Settings
 Manufact: N/A
 Model: _____
 Serial No.: _____
 Linearity Due: _____
 Delay: _____ Range: _____
 Mtl. Vel.: _____ Pulser: _____
 Damping: _____ Reject: _____
 Rep Rate: _____ Freq.: _____
 Filter: _____ Mode: _____

Examination Area / Weld	Access	Recordable Indications			Exam Sens.
		Yes	No	Geom.	
<u>GB-14-F34</u>	<u>SINGLE</u>	<u>N/A</u>	<u>✓</u>	<u>N/A</u>	<u>66.2*</u>

Remarks
 * SCANNED BELOW REFERENCE DUE TO HIGH NOISE LEVELS.

Further Evaluation Required: Yes No

Examiner: [Signature] Level: III Date: 4-25-05
 Examiner: N/A Level: N/A Date: N/A
 Reviewer: [Signature] Level: III Date: 4/27/05
 ANII: [Signature] Date: 4/25

Reference Sensitivity
 Axial: 72.2 Circ: N/A

Reference Sensitivity
 Axial: _____ Circ: _____

ATE/LLC 809



Examination Data Sheet

EDS No: ⁴⁹³ ~~OS-E-380-151~~
 CDS No: ~~OS-C-379-151~~ 492-151
 LDS No: ~~OS-L-378-151~~ 491-151 ^{7/2/05}
 Page: 1 of 4

Plant/Unit: PILGRIM / 1		System: CORE SPRAY		Component: GB-14-F34		Procedure: EWN-NDE-9.10					
Work Order: 08116642		DWG No.: ISI I 14-2B		<input checked="" type="checkbox"/> Carbon Steel <input checked="" type="checkbox"/> Stainless Steel		Start Time/Date: 1345 / 4-25-05					
Examination Area / Weld No.: GB-14-F34		Line No.: 6"-GB-14		Size: 6" Schedule: .280"		Lo Location: N/A Wo Location: N/A					
Ind. #	Angle	% of DAC	Indication Length			Max Location		OD SU Loc.	Scan Direct.	Remarks:	
			L1	L Max	L2	W	MP				
N.R.I.											
Further Evaluation Required: <input type="checkbox"/> Yes <input checked="" type="checkbox"/> No						Limitations: ONE SIDED EXAM - 29.75% C.R.V.					
Remarks N/A											
Examiner: <u>[Signature]</u>			Level: III			Date: 4-25-05			Examiner: N/A		
Reviewer: <u>[Signature]</u>			Level: III			Date: 4/27/05			ANII: <u>[Signature]</u>		

log 08/24/05



Sketch Sheet

Data Sheet No: ⁴⁷³ ~~05-E-350-151~~ ⁷²²⁸ ~~57165~~
 Page: 2 of 4

Plant/Unit: <u>PILGRIM / 1</u>	System: <u>CORE SPRAY</u>	Component: <u>GB-14-F34</u>	Procedure: <u>ENW-NDE-9.6</u>
Examination Area / Weld No.: <u>GB-14-F34</u>	DWG No.: <u>ISI I 14-2B</u>	Line No.: <u>6"-GB-14</u>	Revision: <u>0</u>
			Work Order: <u>03116642</u>

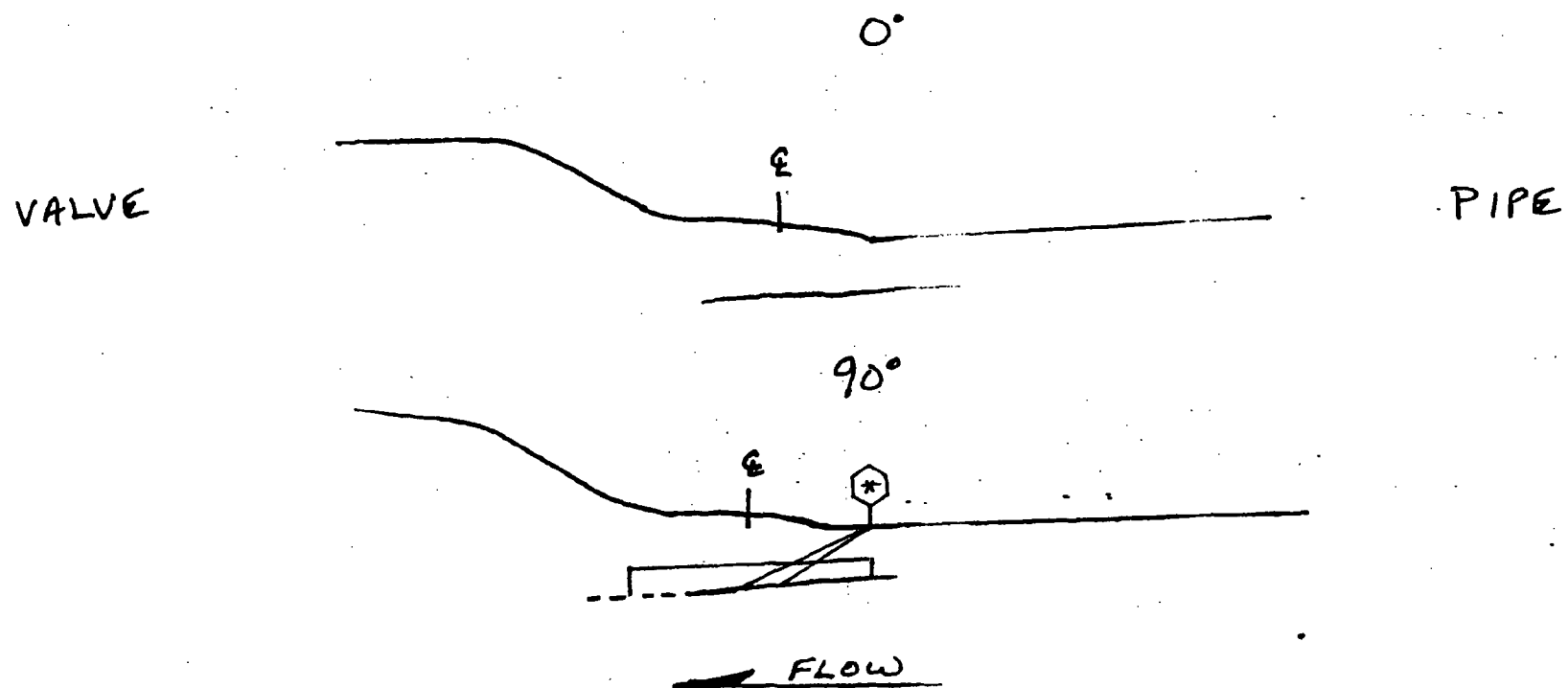

⬡ FORWARD POINT OF 60° & 70° SHEAR EXAMS.

Boor 22/05/05

Examiner: <u>[Signature]</u> Level: <u>III</u> Date: <u>4-25-05</u>	Examiner: <u>N/A</u> Level: <u>N/A</u> Date: <u>N/A</u>
Reviewer: <u>[Signature]</u> Level: <u>III</u> Date: <u>4/27/05</u>	ANII: <u>[Signature]</u> Date: <u>5/2/05</u>



Sketch Sheet

Data Sheet No: ⁴⁹³ 05-E-384-151 ^{may 15/05}
Page: 3 of 4

Plant/Unit: <u>PILGRIM / 1</u>	System: <u>CORE SPRAY</u>	Component: <u>GB-14-F34</u>	Procedure: <u>EAN-NDE-900</u>
Examination Area / Weld No.: <u>GB-14-F34</u>	DWG No.: <u>ISI I 14-2B</u>	Line No.: <u>6" - GB-14</u>	Revision: <u>Ø</u>
			Work Order: <u>03116642</u>

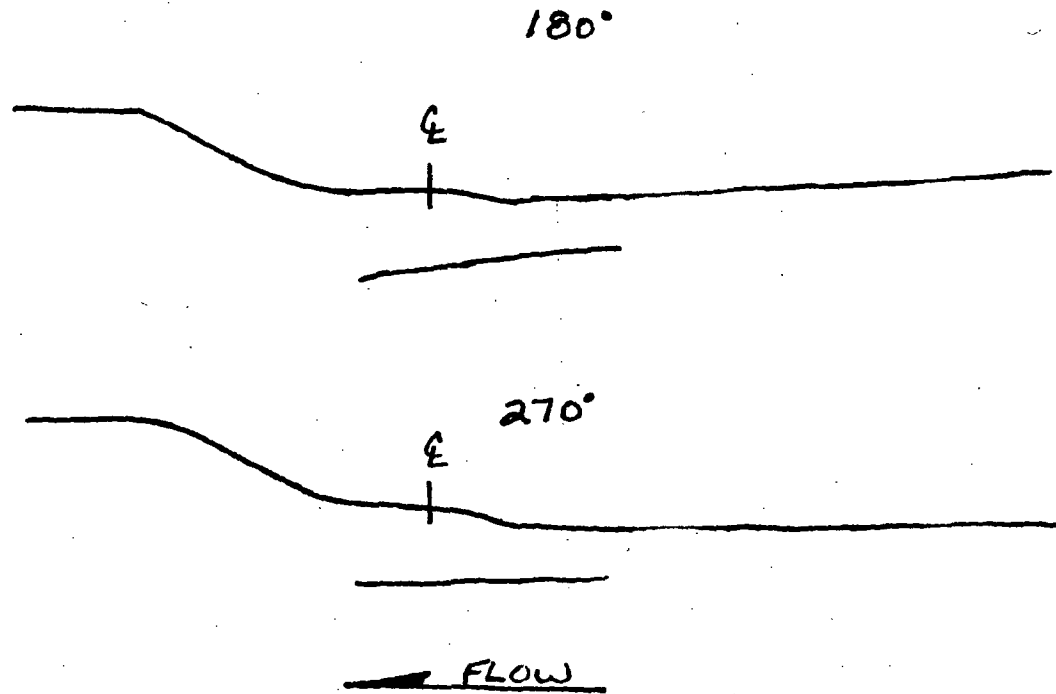

Examiner: <u>[Signature]</u> Level: <u>III</u> Date: <u>4-25-05</u>	Examiner: <u>N/A</u> Level: <u>N/A</u> Date: <u>N/A</u>
Reviewer: <u>[Signature]</u> Level: <u>III</u> Date: <u>4/22/05</u>	ANII: <u>[Signature]</u> Date: <u>5/2/05</u>

Page 27/240



Sketch Sheet

Data Sheet No: ⁴⁹³05-E-~~380~~-151 ^{2nd} 5/7/05
 Page: 4 of 4

Plant/Unit: PILGRIM / 1	System: CORE SPRAY	Component: GB-14-F34	Procedure: ENN-NDE-9.10 Revision: ϕ
Examination Area / Weld No.: GB-14-F34	DWG No.: ISI I 14-2B	Line No.: 6" - GB-14	Work Order: 03116642

GB-14-F34 PREP DID NOT MEET PARA. 5.3.4.9 OF ENN-NDE-9.10. DUE TO SURFACE GAPS EXCEEDING $1/32"$ NO COVERAGE WAS CLAIMED ON WELD IN AX OR. CIRC DIRECTIONS. 60° SHEAR WAS SCANNED IN CIRC DIRECTION TO ENHANCE 45° SCAN DUE TO WIDE WELD CROWN. 60° & 70° RL'S WERE SCANNED FROM PIPE SIDE BUT WELD CROWN REINFORCEMENT PRECLUDED SUFFICIENT FORWARD MOVEMENT FOR SOUND TO REACH THE WELD CENTERLINE.

CODE REQUIRED VOLUME:

AXIAL SCANS - 40%
 CIRC SCANS - 19.5%
 CRV - 29.75%

^{Box} (1.12 1.40) ^{W/O} 4-23-05
 TOTAL EXAM AREA - .154 in²
 AXIAL AREA SCANNED - .0735 in²
 CIRC AREA SCANNED - .013 in²

Examiner: <u>[Signature]</u> Level: <u>III</u> Date: <u>4-25-05</u>	Examiner: <u>N/A</u> Level: <u>N/A</u> Date: <u>N/A</u>
Reviewer: <u>[Signature]</u> Level: <u>III</u> Date: <u>5/23/05</u>	ANII: <u>[Signature]</u> Date: <u>5/7/05</u>

Boq. 228/240

RECORD OF MAGNETIC PARTICLE EXAMINATION			DATA SHEET # <u>03-17-064</u>
ITEM ID/PIECE #	SYSTEM	MR#	ISO/DWG NUMBER
<u>GB-10-9-2E</u>	<u>KIK</u> LOCATION <u>TORUS ROOM</u>	<u>0115999</u>	<u>ISI-I-10-4B 0H.1</u>
A. MATERIAL		TYPE <u>C.S.</u>	
CROSS SECTION THICKNESS	MAX <u>.375"</u>	MIN <u>N/A</u>	PIPE PLATE ROD OTHER GEOMETRY <u>✓</u>
FABRICATION PROCESS		CAST WORKED <u>(WELDED)</u> OTHER _____	
SURFACE		<u>MACHINED GROUND</u> AS OTHER FABRICATED	INSPECTION HOLD PT <u>I.S.I.</u>
SURFACE IS SUITABLE FOR SCHEDULE <input checked="" type="checkbox"/> MT <input checked="" type="checkbox"/> UT EXAMINATION <input checked="" type="checkbox"/> YES <input type="checkbox"/> NO			
SKETCH OR OTHER DETAIL ATTACHED <input checked="" type="checkbox"/> YES <input type="checkbox"/> NO WEIGHT <input checked="" type="checkbox"/> 10 LB <input type="checkbox"/> 40 LB			
B. PROCEDURE #		<u>50.20</u>	
VALIDATION #		<u>N/A</u>	
POLE SPACING		<u>6"</u>	
		EQUIPMENT IDENTIFICATION AC <input checked="" type="checkbox"/> HWAC <input type="checkbox"/>	
		SN <u>70</u>	
C. EVALUATION			
LOCATION	SIZE (INCHES)	DESCRIPTION	ACTION (ACCEPT, REWORK, REJECT AND COMMENT AS NECESSARY)
1.			<u>NRI-ACCEPT</u>
2.			<u>85% coverage obtained.</u>
3.			<u>BP</u>
4.			
5.		<u>ISI GLOOP NOTED.</u>	
6.		<u>BP 4/1/03</u>	
7.			
D. CRITERIA			
COMPONENTS <u>DO NOT MEET</u> ASME SECTION XI CRITERIA FURTHER EVALUATION REQUIRED <input type="checkbox"/> YES <input checked="" type="checkbox"/> NO			
<u>ASME XI 1989</u>			
E. ATTEST		<u>IL</u>	<u>3/27/03</u>
RESPONSIBLE CERTIFIED PERSONNEL		LEVEL	DATE
<u>BP</u>		<u>II</u>	<u>4/11/03</u>
NOT LEVEL III		AMII	DATE

D.S. No. 03-M-064
Pg 2 of 2

DATA SHEET # 03-M-064
COMPONENT # GB 10-9-2E
PAGE 2 OF 2

Page 239/240

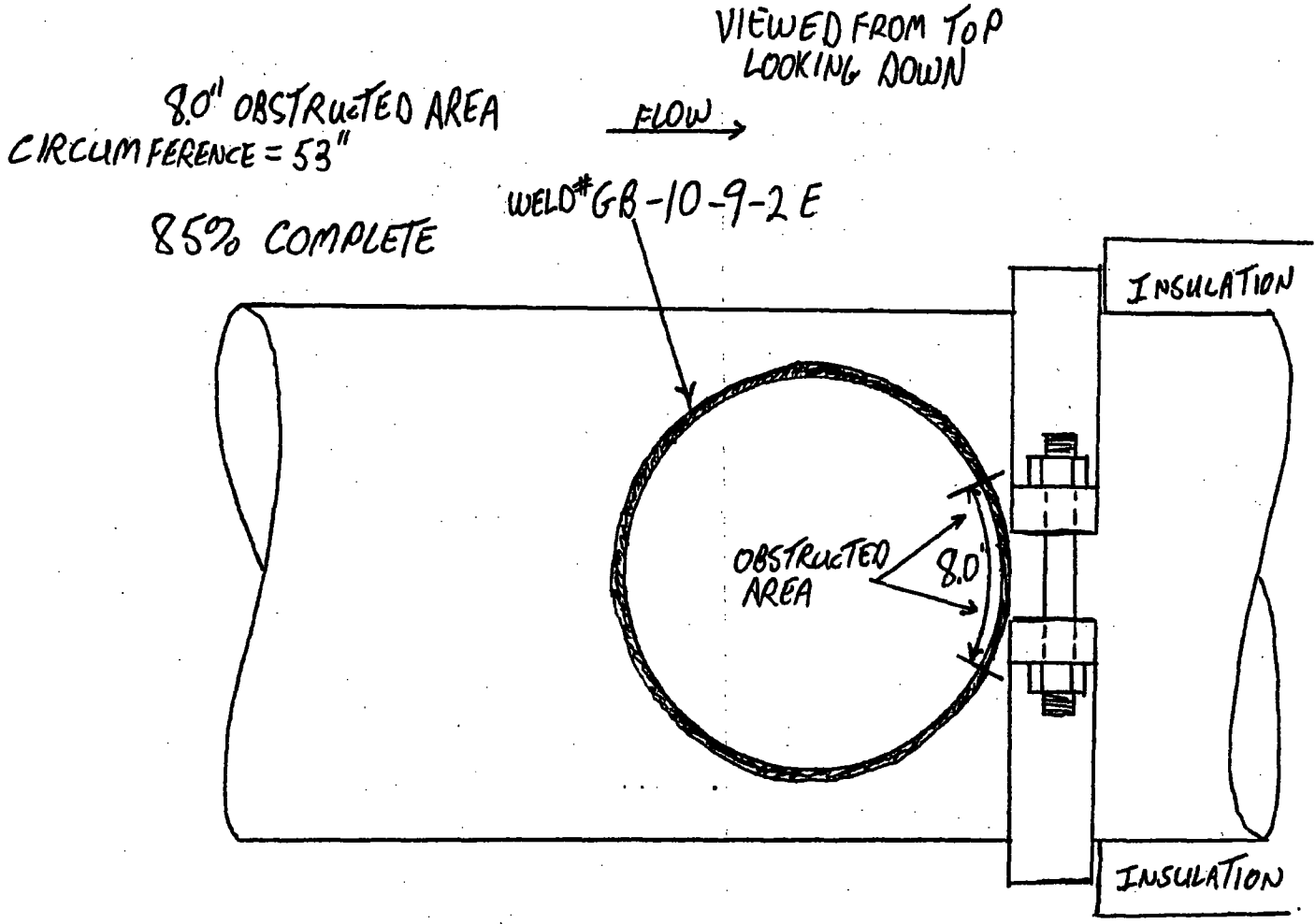

EXAMINER Shawn R. Brown LEVEL II DATE 3-27-03



Calibration Data Sheet

Figure 5

Plant/Unit PILGRIM / U1
 Company ENERGY
 Comp/System RHK
 Procedure No. 5071
 Rev/Chng. No. 610
 Cal. Block No. PIL-47A
 Cal. Block Temp. 67° 11297 Therm S/N
 Size 1R Sch. 0375 T
 Ferritic Austenitic
 Each Major CRT Div. = 0.2 / 0.25
 Cal. Direction: Axial Circ. Both
 Scan Area: || to Weld
|| to Weld

LDS NO. 03-L-016
 Data Sheet # 03-C-072
 Page 1 of 1

Cal. Checks	Time
Initial Calib.	<u>1745</u> <u>1740</u>
Initial Calib. Date	<u>3-27-03</u>
Intermediate	<u>N</u>
Intermediate	<u>A</u>
Final Calib.	<u>2049</u> <u>2050</u>
Final Calib. Date	<u>3-27-03</u>

Couplant

Type: ULTRAFEL II
 Batch: 00325

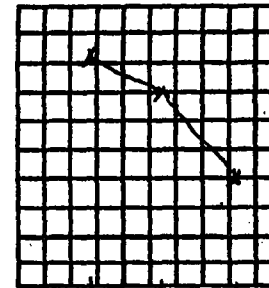

Search Unit #1

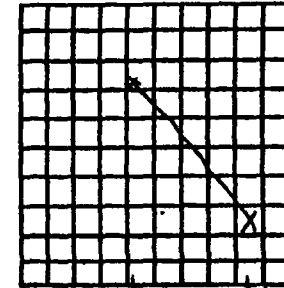

Search Unit #2

Manufacture: KBA
 Serial No.: DDWPLY
 Size: 0.25" Shape: ROUND
 Freq: 5.0 Style: COMP 6
 Exam Angle: 45 Mode: SHEAR
 Measured Angle: 40
 Wedge Style: ST

Manufacture: KBA
 Serial No.: DDWPLY
 Size: 0.25" Shape: ROUND
 Freq: 5.0 Style: COMP 6
 Exam Angle: 70 Mode: SHEAR
 Measured Angle: 71
 Wedge Style: ST

Search Unit Cable
 Type: RG-174/U
 Length: 6' No. 0

Search Unit Cable
 Type: RG-174/U
 Length: 6' No. 0

Instrument Settings
 Make/Model: STAVLEY/SONIC-136
 Serial No.: 8011300
 Delay: 0.167 Range: 2.0
 M'tl Cal/Wet: 0125 Pulsar: LOOPS
 Damping: 500.0 Reject: OFF
 Rep. Rate: 4K Freq: 5.0
 Filter: 1 Mode: P/E
 Reference Sensitivity (Sens.)
 Axial: 34.6 Circ: 34.6
 SCAN SENS: 58.0

Instrument Settings
 Make/Model: STAVLEY/SONIC-136
 Serial No.: 8011300
 Delay: 0.371 Range: 2.5
 M'tl Cal/Wet: 0126 Pulsar: LOOPS
 Damping: 500.0 Reject: OFF
 Rep. Rate: 4K Freq: 5.0
 Filter: 1 Mode: P/E
 Reference Sensitivity (Sens.)
 Axial: 60.0 Circ: NA
 SCAN SENS: 67.0

Examination Area/Weld	Access	Recordable Indications			Exam Sens.
		Yes	No	Geom	
<u>GB-10-9-2E</u>	<u>WIDE SIDE</u>	<u>NA</u>	<u>X</u>	<u>NA</u>	<u>67</u>
	<u>N</u>				
	<u>A</u>				

Remarks/Reason for Incomplete Scan(s) SEE ATTACHED DRAWING FOR INCOMPLETE AREAS

EXAM IS 63.75% COMPLETE

Examiners: William P. Brown Level III Date 3-27-03
NA Level NA Date NA

Reviewers: B.P. Perkins Further Evaluation Required? Yes No
Entropy III 4-2-03

Page 23/240

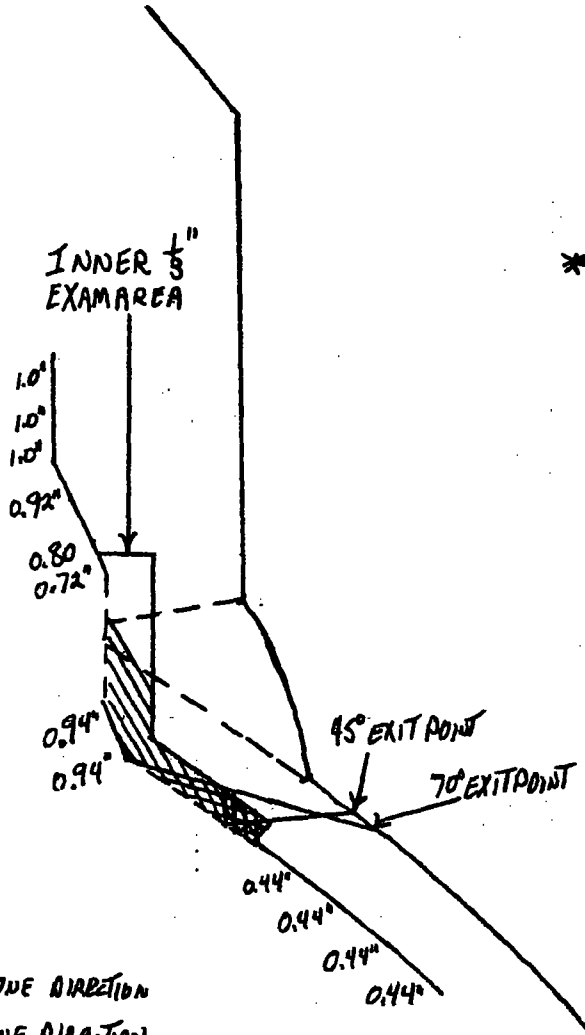

* GEOMETRY IS worse on this side as compare to profile side.
 B Perkins
 4-2-03

$19.292 - 3.185 = 16.107$
 $19.292 - 10.803 = 8.489$

$16.107 \div 19.292 = 83.5\%$ ONE DIRECTION
 $8.489 \div 19.292 = 44\%$ ONE DIRECTION
 $127.5\% \div 2 = 63.75\%$ TOTAL COVERAGE

CIRCUMFERENCE = 53"
 INNER $\frac{1}{8}$ = 0.364 SQ IN.
 TOTAL CU IN = 19.292 5.096
 14" NO SCAN TOTAL CU IN = 4.356 ^{2.03} 3.2703
 MISSED SCAN AREA
 $70^\circ = 3.185$ CU IN MISSED ONE DIRECTION
 $70^\circ = 10.803$ CU IN MISSED ONE DIRECTION

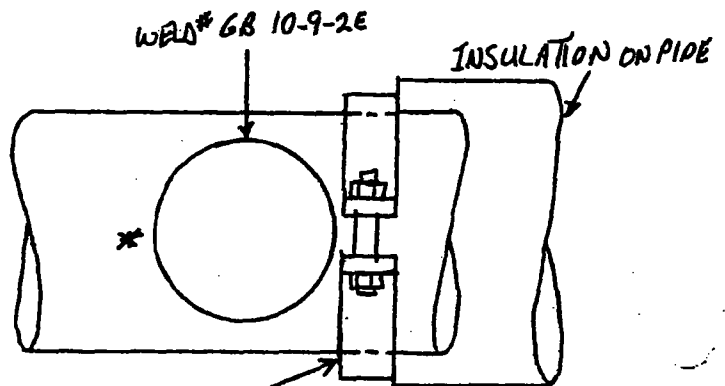

14" NO SCAN DUE TO PIPE CLAMP OBSTRUCTION

EXAMINER Edward R. Dawn LEVEL III DATE 3-28-03



Calibration Data Sheet

CDS No: 05-c-338-151
 LDS No: 05-L-333-151
 Page: 1 of 1

Plant/Unit: PILGRIM / 1
 System: RCIC
 Component: HE-26-F238
 Line No.: 6"-HE-26
 Procedure: ENN-NDE-9.04 Rev.: 1
 Thermometer SN: 229
 Cal. Blk Temp.: 68°F Comp Temp.: 73°F
 Cal. Block No.: PIL-39A
 Carbon Steel Stainless Steel
 Size: 6" Sch.: .280"

Work Order: 03116633
 DWG No.: ZSE I 13-5

Cal Checks	Time
Initial Cal.:	<u>1620/1625</u>
Date:	<u>3-28-05</u>
Inter. Cal.:	
Date:	
Inter. Cal.:	<u>N/A</u>
Date:	
Final Cal.:	<u>1910/1913</u>
Date:	<u>2-28-05</u>

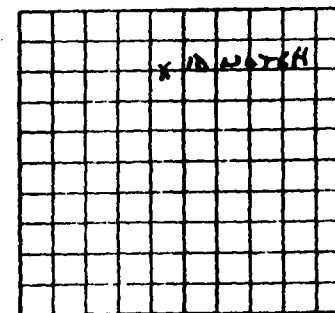
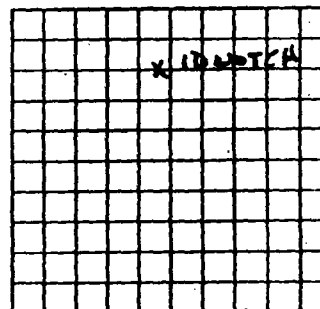

Cal Direction Axial Circ Both
 Scan Area \perp to weld
 Scan Area \parallel to weld

Couplant
 Type: ULTRAGEL II
 Batch: 01225

Search Unit # 1
 Manufacturer: KBA
 Model: COMP-G
 Serial No.: 0114 PT
 Size: .25" Shape: ROUND
 Freq.: 5 MHz # Elm: 1
 Angle: 70° Mode: SHEAR
 Measured Angle: 69
 Wedge Style: MSWQC

Search Unit # 2
 Manufacturer: KBA
 Model: COMP-G
 Serial No.: 0114 PW
 Size: .25" Shape: ROUND
 Freq.: 5 MHz # Elm: 1
 Angle: 45° Mode: SHEAR
 Measured Angle: 45
 Wedge Style: MSWQC

Search Unit Cable
 Type: RG 174
 Length: 6' # Con.: Ø

Search Unit Cable
 Type: RG 174
 Length: 6' # Con.: Ø

Instrument Settings
 Manufacturer: KRAUTKRAMER
 Model: USN 52L
 Serial No.: 00HFX2
 Linearity Due: 4-4-05
 Delay: 5.653 Range: 1.500
 Mtl. Vel.: 1370 Pulsar: SINGLE
 Damping: 1000 Reject: OFF
 Rep Rate: HIGH Freq.: 2-8

Instrument Settings
 Manufacturer: KRAUTKRAMER
 Model: USN 52L
 Serial No.: 00HFX2
 Linearity Due: 4-4-05
 Delay: 2.836 Range: 1.000
 Mtl. Vel.: 1262 Pulsar: SINGLE
 Damping: 1000 Reject: OFF
 Rep Rate: HIGH Freq.: 2-8

Reference Sensitivity
 Axial: 51.0 Circ: N/A

Reference Sensitivity
 Axial: N/A Circ: 18.0

Examination Area / Weld	Access	Recordable Indications			Exam Sens.
		Yes	No	Geom.	
<u>HE-26-F238</u>	<u>BOTH</u> <u>SINGLE</u>	<u>N/A</u>	<u>✓</u>	<u>N/A</u>	<u>450/300</u>

Remarks
LAMINATION SCAN - N.R.I.

Further Evaluation Required: Yes No

Examiner: [Signature] Level: III Date: 3-28-05
 Examiner: N/A Level: N/A Date: N/A
 Reviewer: [Signature] Level: III Date: 4-4-05/4/15
 ANII: [Signature] Date: 4/15/05

8096 234/240



Examination Data Sheet

EDS No: 05-E-339-151
 CDS No: 05-C-338-151
 LDS No: 05-L-333-151
 Page: 1 of 2

Plant/Unit: <u>PILGRIM / 1</u>			System: <u>RCIC</u>				Component: <u>HE-26-F238</u>			Procedure: <u>ENH-NDE-9.04</u> Revision: <u>1</u>		
Work Order: <u>03116633</u>			DWG No.: <u>ISI I 13-5</u>				<input checked="" type="checkbox"/> Carbon Steel <input type="checkbox"/> Stainless Steel			Start Time/Date: <u>1735</u> Finish Time/Date: <u>1815</u>		
Examination Area / Weld No.: <u>HE-26-F238</u>			Line No.: <u>6"-HE-26</u>				Size: <u>6"</u> Schedule: <u>.280"</u>			Lo Location: <u>N/A</u> Wo Location: <u>N/A</u>		
Ind. #	Angle	% of DAC	Indication Length			Max Location		OD SU Loc.	Scan Direct.	Remarks:		
			L1	L Max	L2	W	MP					
<u>NRI</u>												
Further Evaluation Required: <input type="checkbox"/> Yes <input checked="" type="checkbox"/> No								Limitations: <u>ONE SIDED EXAM</u>				
Remarks: <u>NO RECORDABLE IND FOR LAMINATION SCAN</u>												
Examiner: <u>[Signature]</u> Level: <u>III</u> Date: <u>3-28-05</u>				Examiner: <u>N/A</u> Level: <u>N/A</u> Date: <u>N/A</u>								
Reviewer: <u>[Signature]</u> Level: <u>III</u> Date: <u>4-4-05</u>				ANII: <u>[Signature]</u> Date: <u>4/2/05</u>								
Reviewer: <u>Nichol Stone</u> Level: <u>III</u> Date: <u>4/4/05</u>												

Page 235/240



Sketch Sheet

Data Sheet No: 05-E-339-151

Page: 2 of 2

Plant/Unit: <u>PILGRIM / 1</u>	System: <u>RCIC</u>	Component: <u>HE-26-F238</u>	Procedure: <u>ENW-NDE-9.04</u>
Examination Area / Weld No.: <u>HE-26-F238</u>	DWG No.: <u>ISI I 13-5</u>	Line No.: <u>6" HE-26</u>	Revision: <u>1</u>
			Work Order: <u>03116633</u>

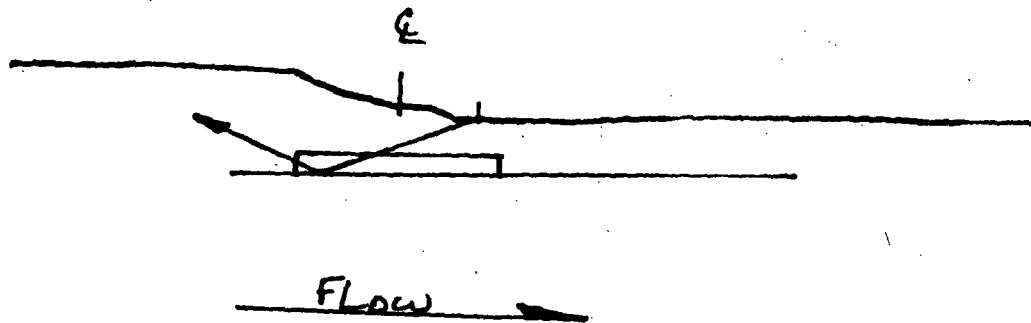

AXIAL SCAN - 87.5%

CIRC SCAN - 50%

TOTAL CODE REQUIRED VOLUME - 68.75%

Examiner: [Signature] Level: III Date: 3-28-05

Reviewer: [Signature] Level: III Date: 4-4-05

Examiner: N/A Level: N/A Date: N/A

ANII: [Signature] Date: 4/2/05

REVISIONS: [Signature] III 4/4/05

Page 236/244

This page intentionally left blank

Page 237/240

This page intentionally left blank

Page 238/240

This page intentionally left blank

Page 239/240

This page intentionally left blank

Page 240/240

RESPONSES FOR PRR-42 RAI (PRR-42 Rev. 1)

Attachment 2 to Entergy Letter No. 2.07.076

Response to NRC Request for Additional Information

RESPONSES FOR PRR-42 RAI (PRR-42 Rev. 1)

2.2.1 *The licensee requested relief for several RPV longitudinal shell welds. It was noted that no relief for circumferential shell welds (with exception of RPV-BH-C1) was included, and it is assumed that PNPS has submitted an alternative in accordance with "BWR [boiling-water reactor] Vessel and Internals Project, BWR Reactor Pressure Vessel Shell Weld Inspection Recommendations (BWRVIP-05)" to exclude examination of the RPV circumferential shell welds. Please list the date of the NRC SER which authorizes the use of BWRVIP-05, or include a copy of the SER when responding to this RAI.*

2.2.1 RESPONSE:

NRC approval of Pilgrim Relief Request (PRR)-28, Rev. 1 provides for the use of BWRVIP-05 to exclude circumferential shell welds [Reference: NRC SER, "Pilgrim Nuclear Power Station-Pilgrim relief Request No. 28, relief From ASME Code , Section XI, Examinations of Reactor Pressure Vessel Circumferential Shell Welds (TAC No. MB6074), dated April 11, 2003].

RESPONSES FOR PRR-42 RAI (PRR-42 Rev. 1)

2.2.2 *The coverage sketches included in ultrasonic reports for bottom head-to-shell circumferential Weld RPV-BH-C1 are unclear. Please re-submit cross-sectional sketches, or full written descriptions, describing ASME Code-required volumes and areas of completed coverage for each of the techniques (near surface, inner 15%, and full volume) used on this weld. Summarize the scanning directions and techniques, list the materials for the base metal and weld, and clarify whether the methods used have been qualified in accordance with performance demonstration requirements per ASME Section XI, Appendix VIII.*

2.2.2 RESPONSE:

Total ultrasonic examination coverage of weld RPV-BH-C1 is impractical due to obstructions or limiting component configuration that adversely affect the scan paths for required ultrasonic beam projections required to achieve complete examination coverage.

Weld RPV-BH-C1 is the Reactor Pressure Vessel bottom head to shell weld. Both the base and weld material are carbon steel.

This weld was ultrasonically examined manually utilizing General Electric Energy Nuclear Procedure GE-UT-300 Version 8. This procedure is qualified by EPRI PDI to ASME Section XI, Appendix VIII, Supplements 4 & 6 for ultrasonic examination of reactor pressure vessel welds with dual or single side access. Report No. PIL-R15-05-002 is attached as Reference A.

Scanning was performed from one side of the weld due to the configuration of the reactor vessel support skirt assembly configuration. Scans were performed in both the Transverse (scanning transverse or perpendicular to the weld) and Parallel (scanning parallel to the weld in two directions 180 degrees to each other) directions. In the attached UT report, the Transverse scans are referred to as "T-Scans" and the Parallel scans as "P-Scans."

Limitations in weld coverage were identified due to both the Reactor Pressure Vessel (RPV) support skirt configuration (proximity to the weld) and three thermocouple pads each about 5" in length. The limitation caused by the support skirt exists for the entire weld length. The thermocouple limitation locations are identified on Report No. PIL-R15-05-002, Data Sheet Numbers UT-086 and UT-089 in the "Comments" section. Modified coverage sketches from Report No. PIL-R15-05-002, identified as Attachment A Sketch 1 and Sketch 2, are also attached and indicate the weld examination volume required by ASME Section XI, Appendix VIII Supplements 4 & 6. These sketches also indicate the limited coverage areas for both the T and P scans. The Table on page 10 of 12 of Report No. PIL-R15-05-002, summarize the limitation percentages. Total composite coverage for this weld is 75%.

RESPONSES FOR PRR-42 RAI (PRR-42 Rev. 1)

2.2.3 Similarly, the examination reports for the remaining RPV longitudinal shell and shell-to-flange welds do not adequately describe completed examination coverages. Please submit cross-sectional sketches, or full written descriptions, describing ASME Code-required volumes and areas of completed coverage for each of the techniques (near surface, inner 15%, and full volume) used on the following welds:

Weld ID	Weld Type
<i>RPV-L-1-338A</i>	<i>Lower Intermediate Shell Vertical Weld</i>
<i>RPV-L-1-338C</i>	<i>Lower Intermediate Shell Vertical Weld</i>
<i>RPV-L-2-338A</i>	<i>Lower Shell Vertical Weld</i>
<i>RPV-L-2-338B</i>	<i>Lower Shell Vertical Weld</i>
<i>RPV-L-2-338C</i>	<i>Lower Shell Vertical Weld</i>
<i>RPV-L-2-339A</i>	<i>Upper Intermediate Shell Vertical Weld</i>
<i>RPV-L-2-339B</i>	<i>Upper Intermediate Shell Vertical Weld</i>
<i>RPV-L-2-339C</i>	<i>Upper Intermediate Shell Vertical Weld</i>
<i>RPV-BH-C1</i>	<i>Bottom Head-to-Shell Circumferential Weld</i>
<i>RPV-SF-0-120</i>	<i>Shell to Flange Weld (0 to 120 degrees)</i>
<i>RPV-SF-120-240</i>	<i>Shell to Flange Weld (120 to 240 degrees)</i>
<i>RPV-SF-240-360</i>	<i>Shell to Flange Weld (240 to 360 degrees)</i>

In addition, summarize the scanning directions and techniques, list the materials for the base metal and welds, and clarify whether the methods used have been qualified in accordance with performance demonstration requirements per ASME Section XI, Appendix VIII.

2.2.3 RESPONSE:

Total ultrasonic examination coverage of welds RPV-L-1-338A, RPV-L-1-338C, RPV-L-2-338A, RPV-L-2-338B, RPV-L-2-338C, RPV-L-2-339A, RPV-L-2-339B, RPV-L-2-339C and RPV-C-4-339 is impractical due to obstructions or limiting configuration that adversely affect positioning of the automated scanning tool and thus the scan paths for required ultrasonic beam projections required to achieve complete examination coverage.

These welds are carbon steel RPV shell course vertical welds and RPV shell to flange weld. These welds are all carbon steel component parts welded with carbon steel weld metal. Ultrasonic scanning was performed using the equipment described in Attachment B. The physical dimensions and mode of operation of this tooling are important relative to understanding the limitations described in the table below. All of the limitations associated with these welds are directly associated with issues of the scanner access to the required locations to allow complete ultrasonic coverage. Ultrasonic coverage is based on scanner encoder inputs and calculated from automated data parameters.

These ultrasonic examinations were conducted in accordance with IHI Procedures ISwT-PDI-AUT1, Rev.0 and ISwT-PDI-AUT2, Rev.0. These procedures are qualified by the Performance Demonstration Initiative (PDI) and satisfy the examination requirements of ASME Section XI, Appendix VIII, Supplements 4 and 6. Scanning was performed both in the transverse and parallel directions relative to the welds unless limited by access or configuration.

RESPONSES FOR PRR-42 RAI (PRR-42 Rev. 1)

Attachment B describes the ultrasonic techniques that were utilized for these examinations as well as a sketch of the various projected beam angles and the Code required examination volume.

Attachment C is a roll out sketch of the RPV identifying the location of the various obstructions relative to specific welds. For each of the welds identified in the table below, a number is assigned in () after each identified limitation in the "Description of Obstruction / Limitation" column. The corresponding number appears on Attachment C for that location.

Weld Number	Weld Description	Description of Obstruction / Limitation
RPV-L-1-338A	Intermediate Shell Weld @ 60°	Jet Pump riser brace welded to the RPV wall is directly in the scan path for the transducer array. (1)
RPV-L-1-338C	Intermediate Shell Weld @ 300°	Jet Pump riser brace (2) and RPV Surveillance Specimen Holder and Support Brackets (3) welded to the RPV walls are directly in the scan path for the transducer array. Shroud Tie Bar @ 315° prevents maneuvering of the scanner tooling to fully access the weld. (4)
RPV-L-2-338A	Lower Shell Vertical Weld @ 75°	The Shroud Support and associated gusset plates would not allow the scanner tooling to completely position the transducer array to the bottom of the weld, i.e. where the RPV vertical weld intersects with the shroud support plate. (5)
RPV-L-2-338B	Lower Shell Vertical Weld @ 195°	The Shroud Support and associated gusset plates would not allow the scanner tooling to completely position the transducer array to the bottom of the weld, i.e. where the RPV vertical weld intersects with the shroud support plate. (6)
RPV-L-2-338C	Lower Shell Vertical Weld @ 315°	The Shroud Support and associated gusset plates would not allow the scanner tooling to completely position the transducer array to the bottom of the weld, i.e. where the RPV vertical weld intersects with the shroud support plate. (7) Shroud Tie Bar @ 315° prevents maneuvering of the scanner tooling to fully access the weld. (8) N2K Nozzle radius prevents even contact of the scanner tooling thus scanning in area of the N2K Nozzle inner radius is not possible. (9)
RPV-L-2-339A	Upper Shell Vertical Weld @ 355°	Feedwater (10) and Core Spray Spargers (11) prevent maneuvering of the scanner tooling to fully access the weld.
RPV-L-2-339B	Upper Shell Vertical Weld @ 115°	Feedwater (12) and Core Spray Spargers (13) prevent maneuvering of the scanner tooling to fully access the weld. Angle of ID taper due to RPV shell course plate thickness change (14)
RPV-L-2-339C	Upper Shell Vertical Weld @ 235°	Feedwater (15) and Core Spray Spargers (16) prevent maneuvering of the scanner tooling to fully access the weld.

RESPONSES FOR PRR-42 RAI (PRR-42 Rev. 1)

Weld Number	Weld Description	Description of Obstruction / Limitation
RPV-C-4-339 (previously identified as RPV-SF-0-120, RPV-SF-120- 240 and RPV- SF-240-360)	Shell to Flange Weld from 0° to 360°	The proximity of the Main Steam Nozzles (17), Main Steam Nozzle Plugs (and necessary support tooling) (18), Dryer/Separator Guide Rods at 0° and 180° (19) and configuration of the Shell to Flange weld (see Attachment C).

RESPONSES FOR PRR-42 RAI (PRR-42 Rev. 1)

2.3.1 *The coverage sketches included in ultrasonic reports for nozzle-to-shell Welds RPV-N7A-NV, RPV-N7B-NV, and RPV-N8-NV are unclear. Please re-submit cross-sectional sketches, or full written descriptions, describing ASME Code-required volumes and areas of completed coverage for each of the techniques (near surface, inner 15%, and full volume) used on this weld. Summarize the scanning directions and techniques, list the materials for the base metal and weld, and clarify whether the methods used have been qualified in accordance with performance demonstration requirements per ASME Section XI, Appendix VIII.*

2.3.1 RESPONSE:

Total ultrasonic examination coverage of welds RPV-N7A-NV, RPV-N7B-NV and RPV-N8-NV is impractical due to obstructions or limiting component configuration that adversely affects the scan paths for required ultrasonic beam projections required to achieve complete coverage.

Welds RPV-N7A-NV, RPV-N7B-NV and RPV-N8-NV are Reactor Pressure Vessel nozzle to vessel top head welds. Welds RPV-N7A-NV and RPV-N7B-NV are identical in configuration being of the same size, material and configuration. Both are situated tangential to the circumference of the top head surface and are addressed together. Weld RPV-N8-NV differs in that its location is at the apex or top of the RPV head and is addressed separately.

Both base and weld material are carbon steel for all three nozzle to vessel welds.

These welds were ultrasonically examined manually utilizing General Electric Energy Nuclear Procedures GE-UT-300 Version 8 and GE-UT-311 Version 10. These procedures are qualified by EPRI PDI to ASME Section XI, Appendix VIII, Supplements 4, 5 & 6 for ultrasonic examination of reactor pressure vessel welds with dual or single side access and nozzle inner radius bore and selected nozzle to vessel regions. Refer to Report Nos. PIL-R15-05-026, 028 & 030 for reference.

Scanning was performed from the vessel [head] side of the weld due to the configuration of the nozzle assembly configuration. Scans were performed in both the Transverse (scanning transverse or perpendicular to the weld) and Parallel (scanning parallel to the weld in two directions 180 degrees to each other) directions. In the respective UT reports, PIL-R15-05-026, 028 and 030, the Transverse scans are referred to as "T-Scans" and the Parallel scans as "P-Scans."

Welds RPV-N7A-NV & RPV-N7B-NV

Limitations in weld coverage were identified due to the nozzle configuration (proximity to the weld). This limitation exists at varying degrees for the entire weld length. The limitation locations are identified for the top and bottom side of the nozzle to contrast the configuration differences at these two extreme locations. Report Nos. PIL-R15-05-026 and 028 indicate identical coverage and will be discussed together. Modified coverage sketches from Report No. PIL-R15-05-026, identified as Sketch 3 is included in Attachment A and indicates the weld examination volume required by ASME Section XI, Appendix VIII Supplements 4, 5 & 6. These sketches also indicate the limited coverage areas for both the T and P scans. The Table on page 7 of 8 of Report Nos. PIL-R15-05-026 & 028, summarize the limitation percentages. Note that there were no limitations associated with the inner radius and inner 15% volume coverage (these areas received 100 % coverage by either or both of the Supplement 4 and 5 scanning techniques).

Weld RPV-N8-NV

Nozzle to vessel weld RPV-N8-NV is similar to the configuration described above differing only in the fact that the configuration limitation is uniform around the entire circumference due to its location on the RPV Head.

RESPONSES FOR PRR-42 RAI (PRR-42 Rev. 1)

A modified coverage sketch from Report No. PIL-R15-05-030, identified as Sketch 4 in Attachment A is also attached and indicates the weld examination volume required by ASME Section XI, Appendix VIII Supplements 4, 5 & 6. This sketch also indicates the limited coverage areas for both the T and P scans. The Table on page 6 of 7 of Report No. PIL-R15-05-30, summarizes the limitation percentages. Note that there were no limitations associated with the inner radius and inner 15% volume coverage (these areas received 100 % coverage by either or both of the Supplement 4 and 5 scanning techniques).

RESPONSES FOR PRR-42 RAI (PRR-42 Rev. 1)

2.4.1 Table 3 of relief request PRR-42 contains a listing of multiple limited examinations for Class 1 dissimilar metal piping and nozzle-to-safe end welds that have occurred during the third 10-year interval. The table lists ASME Code Examination Category B-F for each piping and nozzle-to-safe end weld, which would normally indicate that a conventional ISI program has been implemented. Typically, if a risk-informed inservice inspection (RI-ISI) program is being implemented, a new Examination Category R-A is used, which lists welds, or elements, according to expected forms of degradation. However, ASME Item Numbers for both a conventional and RI-ISI program are listed, e.g., R1.11 (B5.10). Item Number R1.11 refers to welds susceptible to thermal fatigue and B5.10 is the conventional designation for RPV nozzle-to-safe end butt welds in piping greater than 4-inch NPS. In addition, Item Number R1.20 (B5.130) is also referenced, but no such Item Number exists within the framework of ASME Code RI-ISI methods (Code Cases N-577 and N-578). Confirm that all Class 1 dissimilar metal welds are part of a RI-ISI program at PNPS, and clarify the designation of Item Number R1.20.

State the total number of Category B-F (new Category R-A) Class 1 dissimilar metal welds that exist at PNPS, the examination sample population of these that are included in the RI-ISI program, and clarify the extent of limited volumetric coverages that resulted during each weld examination. In addition, describe whether PNPS considered performing additional examinations on welds not in the initial RI-ISI examination population to supplement the limited volumetric coverages.

2.4.1 RESPONSE:

Pilgrim received NRC approval on May 2, 2001 to implement a risk-informed inspection program for Class 1 category B-F and B-J piping welds based on the methodology detailed in EPRI Topical Report TR-112657 revision B-A and Code Case N-578 as an alternative to the requirements of the 1989 edition ASME XI code.

The risk-informed methodology used at Pilgrim includes all category B-F and B-J welds in the determination of the final risk-informed inspection sample of 71 Class 1 welds. There are a total of 29 Class 1 dissimilar metal welds at Pilgrim Station with 7 of the DM welds included in the Class 1 risk-informed inspection sample. In accordance with the EPRI risk-informed methodology, augmented programs are relied upon for the inspection of welds not wholly subsumed by the risk-informed process, including IGSCC-susceptible welds. All carbon steel and IGSCC category A austenitic stainless steel welds are subsumed into Pilgrim's risk-informed inspection process while all IGSCC category B, C, D, E and G welds are examined in accordance with the augmented inspection schedules and methods outlined in BWRVIP-75A.

Inspection coverage obtained for six of the seven dissimilar metal welds included in the PNPS risk-informed inspection sample exceeded 90% combined coverage. Reduced coverage for one of the seven welds, Core Spray weld no. 14-A-10A (see PRR-42 Table 3), was caused by a severe valve-to-pipe weld profile (seen in the adjacent photo) that could not be modified to increase inspection coverage without reducing design margin for the configuration. Since this weld is a dissimilar metal weld made with Inconel 182 weld metal, all other similar welds are currently inspected in accordance with BWRVIP-75A Category D weld inspection schedules and methods. As a result, there are no other similarly constructed welds that are not already being inspected that could be added to the risk-informed inspection sample to account for the reduced coverage obtained on 14-A-10A. Additional clarification of the extent of limited volumetric coverages resulting from each weld examination is discussed in LO-WPOLO-2007-00027 CA-7.

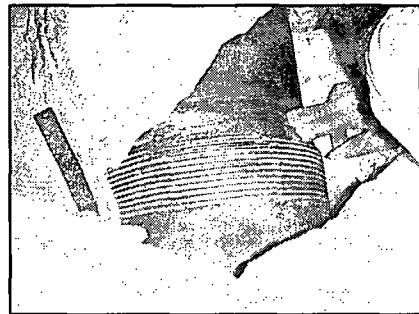

RESPONSES FOR PRR-42 RAI (PRR-42 Rev. 1)

Section XI code item numbers such as B5.10 were included in PRR-42 Table 3 in addition to the new risk-informed item numbers for the sake of completeness as risk-informed inspections were not implemented until the second period of the Pilgrim third ten year inspection interval. Inspections performed during the first period of the Pilgrim third ten year inspection interval were completed in accordance with the 1989 ASME XI code.

In 2001, as part of the risk-informed inservice inspection program application, Class 1 circumferential piping welds were assigned alternate examination category and code item numbers that were consistent with ASME Section XI Code Case N-578-1. The numbering system established in Code Case N-578-1 is similar to the one used in Code Case N-578. However, the Code Case N-578-1 numbering system is more complete and more accurately reflects the technical criteria established in EPRI Topical Report No. TR-112657. For these reasons, the numbering system established in Code Case N-578-1 was used instead of the one shown in Code Case N-578, and is carried forward into the fourth interval. Item number R1.20 as shown in Table 3 of PRR-42 is not listed in Code Case N-578 but was included in Code Case N-578-1 as a means to categorize elements that are not subject to a damage mechanism. Inclusion of item number R1.20 in Table 3 has no substantive impact on relief request PRR-42.

RESPONSES FOR PRR-42 RAI (PRR-42 Rev. 1)

2.4.2 *The coverage sketches included in ultrasonic reports for Examination Category B-F dissimilar metal piping and nozzle-to-safe end welds are unclear. For those welds under a conventional ISI program, please re-submit cross-sectional sketches, or full written descriptions, describing ASME Code-required volumes and areas of completed coverage for each of the techniques used on these welds. Summarize the scanning directions and techniques, list the materials for the base metal and weld, and clarify whether the methods used have been qualified in accordance with performance demonstration requirements per ASME Section XI, Appendix VIII.*

2.4.2 RESPONSE:

Total ultrasonic examination coverage of welds 14-A-10A, 14-B-10A, 2R-N1B-1, 2R-N2E-1, 2R-N2G-1, 2R-N2J-1, 6-N4A-1, 6-N4B-1, 6-N4C-1 and 6-N4D-1 is impractical due to obstructions or limiting component configuration that adversely affects the scan paths for required ultrasonic beam projections required to achieve complete coverage.

Welds 14-A-10A and 14-B-10A

Welds 14-A-10A and 14-B-10A are Core Spray System pipe to valve welds. These welds are essentially constructed identically, differing only in the degree of weld surface preparation/contour.

The valves are stainless steel, welded to carbon steel pipe which had an Inconel 182 welded overlay end preparation on the carbon steel pipe prior to welding. The weld was made utilizing Inconel 182 weld metal.

These welds were ultrasonically examined manually utilizing Entergy Nuclear Procedure ENN-NDE-9.10, Revision 0. This procedure is the equivalent of EPRI PDI generic procedure PDI-UT-10 which meets the requirements of ASME Section XI, Appendix VIII, Supplement 10 for ultrasonic examination of dissimilar metal welds. Report Nos. APR-002 and 005 are attached for reference.

Manual scanning was performed from the pipe side of the weld only. Scanning was performed in both the transverse (scanning transverse or perpendicular to the weld) and parallel (scanning parallel to the weld in both the clockwise and counter clockwise directions). Page 2 of Report Nos. APR-002 and 005 contain a sketch that depicts the procedure required examination volume (full thickness) and the ASME Code required volume (inner 1/3 thickness extending for 1/4" beyond the toe of the weld). In addition, this sketch depicts the scanning direction and coverage for the 45° shear wave, 45° refracted longitudinal wave and 60° refracted longitudinal wave beams.

Examination coverage is extremely limited on these welds due to the pipe to valve configuration. Qualified examination coverage could only be claimed for the carbon steel base material and weld heat affected zone on the pipe side. Weld 14-B-10A exhibited significantly less coverage due to excessive grinding at the toe of the weld on the pipe side, creating areas of transducer "lift-off." Further conditioning was evaluated but could not be accomplished due to minimum wall considerations. These conditions resulted in examination coverage for these welds as follows: 14-A-10A (22.9% procedural coverage and 37.1% code coverage) and 14-B-10A (10.1% procedural coverage and 22.1% code coverage).

Weld 2R-N1B-1

Weld 2R-N1B-1 is a Reactor Recirculation System RPV outlet safe-end to nozzle weld.

RESPONSES FOR PRR-42 RAI (PRR-42 Rev. 1)

The safe-end is 316 stainless steel with an Inconel 182 weld overlay end preparation, welded to the carbon steel RPV inlet nozzle which also has an Inconel 182 welded overlay end preparation. The weld was made utilizing Inconel 82 (root pass) and 182 weld metal.

This weld was ultrasonically examined utilizing General Electric Energy Nuclear Procedure GE-UT-209 Version 17. This procedure is qualified by EPRI PDI to ASME Section XI, Appendix VIII, Supplement 10 for automated ultrasonic examination of dissimilar metal welds with single sided access. Report No. APR-007 is attached for reference.

Automated scanning was performed from both sides of the weld in both the Transverse (scanning transverse or perpendicular to the weld) and Parallel (scanning parallel to the weld in both the clockwise and counter clockwise directions). Page 2 of Report No. APR-007 contains a sketch that depicts the procedure required examination volume (full thickness) which incorporates the ASME Code required volume (inner 1/3 thickness extending for 1/4" beyond the toe of the weld). In addition, this sketch depicts the scanning direction and coverage for the 45° shear wave, 45° refracted longitudinal wave and 60° refracted longitudinal wave beams.

The weld examination coverage percentage stated on page 1 of the report was calculated by the UT data analyst utilizing his discretion as to where the ultrasonic transducers were "lifting off" the component surface due surface contour irregularities rendering the data acquired in those areas to be unusable. The data analyst performed coverage calculations using transducer positioning information in the analysis software. These calculations resulted in the following UT examination coverage percentages: 2R-N1B-1 73% procedure coverage & 75% code required coverage.

Welds 2R-N2E-1, 2R-N2G-1 and 2R-N2J-1

Welds 2R-N2E-1, 2R-N2G-1, 2R-N2J-1 are Reactor Recirculation System RPV inlet safe-end to nozzle welds. These welds are essentially constructed identically, differing only in the degree of weld surface preparation/contour.

The safe-end is 316 stainless steel with an Inconel 182 weld overlay end preparation, welded to the carbon steel RPV inlet nozzle which also has an Inconel 182 welded overlay end preparation. The welds were made utilizing Inconel 82 (root pass) and 182 weld metal.

These welds were ultrasonically examined utilizing General Electric Energy Nuclear Procedure GE-UT-209 Version 17. This procedure is qualified by EPRI PDI to ASME Section XI, Appendix VIII, Supplement 10 for automated ultrasonic examination of dissimilar metal welds with single sided access. Report Nos. APR-009, 011 and 012 are attached for reference.

Automated scanning was performed from both sides of the welds in both the Transverse (scanning transverse or perpendicular to the weld) and Parallel (scanning parallel to the weld in both the clockwise and counter clockwise directions). Pages 2 and 3 of Report Nos. APR-009, 011 and 012 contain sketches of both the procedure required examination volume (page 2 [full thickness]) and the ASME Code required volume (page 3 [inner 1/3 thickness extending for 1/4" beyond the toe of the weld]). In addition, these sketches show the scanning direction and coverage for the 45° shear wave, 45° refracted longitudinal wave and 60° refracted longitudinal wave beams.

The weld examination coverage percentages stated on page 1 of the reports was calculated by the UT data analyst utilizing his discretion as to where the ultrasonic transducers were "lifting off" the component surface due surface contour irregularities rendering the data acquired in those areas to be unusable. The data analyst performed coverage calculations using transducer positioning information in the analysis software. These calculations resulted in the following UT examination coverage percentages: 2R-N2E-1 79.1% procedure coverage & 81.2% code required coverage, 2R-N2G-1, 71.8% procedure coverage & 75.3% code required coverage, 2R-N2J-1, 65.7% procedure coverage & 75% code required coverage.

RESPONSES FOR PRR-42 RAI (PRR-42 Rev. 1)

Welds 6-N4A-1, 6-N4B-1, 6-N4C-1 and 6-N4D-1

Welds 6-N4A-1, 6-N4B-1, 6-N4C-1 and 6-N4D-1 are Reactor Feedwater System RPV inlet safe-end to nozzle welds. These welds are essentially constructed identically.

The safe-end is carbon steel as is the RPV nozzle. These welds were made using carbon steel weld metal, thus they do not meet the criteria of a Category B-F dissimilar metal weld. The B-F category was assigned to these welds early in the third interval to ensure that all of the welds immediately off of the RPV were examined (Category B-F required 100% of the population be examined). These welds have since been re-categorized as Category R-A and examined under the Risk Informed Program.

These welds were ultrasonically examined manually utilizing Boston Edison Company (BECO) procedure QCI 50.71, Revision 4. This procedure was not qualified by EPRI PDI to ASME Section XI, Appendix VIII, although the UT examiners that performed the examinations did have ferritic weld examination PDI qualifications. Report Nos. 99-C-547 and 99-C-549 are attached for reference. Scanning was performed from both sides of the welds in both the transverse (scanning transverse or perpendicular to the weld) and Parallel (scanning parallel to the weld in both the clockwise and counter clockwise directions) utilizing both 45° and 60° shear wave techniques.

Since no cross sectional sketches were made of these welds at the time of examination, an assumption was made in calculating the limited examination coverage. This assumption concluded that for areas not identified as being limited, total coverage was achieved. Therefore, the total lengths of limited examination areas were divided by the total weld lengths to determine the percentage of limited examination coverage for each weld resulting in the percentages identified in Table 3.

2.4.3 *In light of recent industry experience with cracking in these weldments, confirm that all Category B-F piping dissimilar metal welds containing Alloy 600, 82, and 182 are being volumetrically examined at PNPS with techniques that have been qualified through ASME Section XI, Appendix VIII, Supplement 10.*

2.4.3 RESPONSE:

There are 21 dissimilar metal welds at Pilgrim that are constructed with Inconel weld material. These welds are classified in accordance with BWRVIP-75A and Generic Letter 88-01 guidance based on their metallurgy, construction history and environmental conditions. One weld is classified as Category A, 17 welds are Category D and 3 are Category E weld overlays as discussed below. Currently, 20 of these 21 DM welds have been volumetrically examined using Appendix VIII/Performance Demonstration Initiative (PDI) methods. The one weld that has not yet been examined using PDI procedures is the Category E jet pump instrumentation nozzle safe end weld (weld no. RPV-N9A-1) that was repaired by weld overlay in 1984. This overlay weld was last examined with pre-PDI UT procedures in 1999 and is currently scheduled for re-examination with PDI procedures in April 2009.

RESPONSES FOR PRR-42 RAI (PRR-42 Rev. 1)

2.5.1 *In addition to the information requested in item 2.1 above, discuss whether any other surface or visual examinations are possible for the remaining unexamined portions of integral attachment Weld RPV-SBW-0. State why 37% coverage is adequate to ensure that degradation, should it occur, will be detected.*

2.5.1 RESPONSE:

Pilgrim has four code category B-H reactor pressure vessel (RPV) stabilizer assemblies, each with one integral attachment to the RPV outside surface. The 1989 ASME XI code used during the PNPS 3rd inspection interval did not require examinations of code category B-H and B-K-1 integral attachments during the 3rd and 4th intervals. An augmented 10% sample of these welds at PNPS was subsequently mandated by the NRC during the 3rd interval. One RPV stabilizer assembly integral attachment weld was selected as part of this augmented inspection sample. Each rectangular integral attachment (dimensions 12 in. wide x 4.375 in. high) is welded on the top and bottom sides only and has a total of 24 inches of weld length.

Only the upper horizontal surface of the attachment weld (12 in. length) is accessible due to the welded attachment being at essentially the same elevation as the upper surface of the reactor bioshield. In addition, the close proximity of the RPV stabilizer assembly itself and the bioshield wall prohibits examination of the bottom side of the attachment. As a result, only 12 inches of a total 24 inches of weld length can be examined on each integral attachment.

In response to the reduced coverage obtained at the selected integral attachment, Pilgrim subsequently inspected during the third interval the upper 12 inch long sides of all four RPV stabilizer assembly integral attachments using surface examination techniques. This ultimately obtained 48 inches of total combined weld coverage. This yields a combined coverage of 200% when compared to the required coverage for one attachment (24 in.). This result, while not obtaining greater than 90% coverage of any one integral attachment, exceeds the required inches of weld length by a factor of two and provides adequate assurance that degradation would be detected if present. Degradation is considered unlikely as no known degradation mechanism has been identified for these welds due to their carbon steel construction and service conditions.

RESPONSES FOR PRR-42 RAI (PRR-42 Rev. 1)

2.6.1 *Table 3 of relief request PRR-42 contains a listing of multiple limited examinations for Class 1 piping welds that have occurred during the third 10-year interval. The table lists ASME Code Examination Category B-J for each piping weld, which would normally indicate that a conventional ISI program has been implemented. Typically, if a risk-informed inservice inspection (RI-ISI) program is being implemented, a new Examination Category R-A is used, which lists welds, or elements, according to expected forms of degradation. However, ASME Item Numbers for both a conventional and RI-ISI program are listed, e.g., R1.11 (B9.11). Item Number R1.11 refers to welds susceptible to thermal fatigue and B9.11 is the conventional designation for Circumferential butt welds in piping greater than 4-inch NPS. In addition, Item Number R1.20 (B9.11) is also referenced, but no such Item Number exists within the framework of ASME Code RI-ISI methods (Code Cases N-577 and N-578). Confirm that all Class 1 piping welds are part of a RI-ISI program at PNPS, and clarify the designation of Item Number R1.20.*

State the total number of Category B-J (new Category R-A) Class 1 piping welds that exist at PNPS, the examination sample population of these that are included in the RI-ISI program, and clarify the extent of limited volumetric coverages that resulted during each weld examination. In addition, describe whether PNPS considered performing additional examinations on welds not in the initial RI-ISI examination population to supplement the limited volumetric coverages.

2.6.1 RESPONSE:

Pilgrim received NRC approval on May 2, 2001 to implement a risk-informed inspection program for Class 1 category B-F and B-J piping welds based on the methodology detailed in EPRI Topical Report TR-112657 revision B-A and Code Case N-578 as an alternative to the requirements of the 1989 Edition ASME XI code.

The risk-informed methodology used at Pilgrim includes all category B-F and B-J welds in the determination of the final risk-informed inspection sample of 71 Class 1 welds. There are a total of 598 Class 1 code category B-J (now R-A) welds at Pilgrim Station with 60 of these welds included in the Class 1 risk-informed inspection sample. In accordance with the EPRI risk-informed methodology, augmented programs are relied upon for the inspection of welds not wholly subsumed by the risk-informed process, including IGSCC-susceptible welds. All carbon steel and IGSCC category A austenitic stainless steel welds are subsumed into Pilgrim's risk-informed inspection process while all IGSCC category B, C, D, E and G welds are examined in accordance with the augmented inspection schedules and methods outlined in BWRVIP-75A.

Section XI Code item numbers such as B9.11 were included in PRR-42 Table 3 in addition to the new risk-informed item numbers for the sake of completeness as risk-informed inspections were not implemented until the second period of the Pilgrim third ten year inspection interval. Inspections performed during the first period of the Pilgrim third ten year inspection interval were completed in accordance with the 1989 ASME XI code.

In 2001, as part of the risk-informed inservice inspection program application, Class 1 circumferential piping welds were assigned alternate examination category and code item numbers that were consistent with ASME Section XI Code Case N-578-1. The numbering system established in Code Case N-578-1 is similar to the one used in Code Case N-578. However, the Code Case N-578-1 numbering system is more complete and more accurately reflects the technical criteria established in EPRI Topical Report No. TR-112657. For these reasons, the numbering system established in Code Case N-578-1 was used instead of the one shown in Code Case N-578, and is carried forward into the fourth interval. Item number R1.20 as shown in Table 3 of PRR-42 is not listed in Code Case N-578 but was included in Code Case N-578-1 as a means to categorize elements that are not subject to a damage mechanism. Inclusion of item number R1.20 in Table 3 is administrative in nature and has no substantive impact on relief request PRR-42.

RESPONSES FOR PRR-42 RAI (PRR-42 Rev. 1)

Clarification of the extent of limited volumetric coverages resulting from each weld examination is discussed in LO-WPOLO-2007-00027 CA-11. To summarize, the examinations of seven welds in the PNPS risk-informed inspection program during the 3rd interval failed to obtain greater than 90% coverage. Of those seven welds, one is a dissimilar metal Core Spray pipe-to-valve weld (14-A-10A). All similar DM welds are already included in the BWRVIP-75A inspection sample. Another weld, Main Steam Drain carbon steel pipe-to-valve weld 1-SD-10R had obtained coverage of 87.5%, amounting to one inch of weld length that could not be obtained due to the pipe-to-valve configuration. This difference was considered insignificant when the examination of 21 additional inches of weld metal from the three new welds being added to the inspection sample are considered.

For the remaining five welds in the PNPS risk-informed inspection program that failed to obtain greater than 90% coverage, Entergy will revise the risk-informed inspection program by adding three additional weld examinations to account for the limited volumetric coverage obtained during the third interval risk-informed inspections. Three additional welds are from the same systems, are of equivalent risk ranking and have been scheduled for examination during the next refueling outage in 2009. The table below provides details of the extra coverage provided by the new welds.

WELD No.	UT COVERAGE IN 3 rd INTERVAL (%)	RISK RANKING	DIA. (in.)	WELD LENGTH MISSED FROM 100% COVERAGE (in.)	WELD LENGTH ADDED (in.)	REMARKS
10R-IA-6	50	HIGH	18	28	---	
10R-IA-7	50	HIGH	18	28	---	
10R-IB-4	---	HIGH	18	---	57	to be added to RISI Program
2R-HB-1	50	MEDIUM	12	19	---	
2R-HB-4	50	MEDIUM	12	19	---	
2R-HB-3	---	MEDIUM	22	---	69	to be added to RISI Program
12-O-24	50	MEDIUM	6	9	---	
12R-O-8	---	MEDIUM	6	---	19	to be added to RISI Program
14-A-10A	37.1	MEDIUM	10	20	---	All DM welds currently included in BWRVIP-75A inspection program
1-SD-10R	87.5	HIGH	3	1	---	
TOTAL	---		---	124 in.	145 in.	

* welds added to PNPS risk-informed program to account for reduced coverage in 3rd interval are shown in **bold font**.

RESPONSES FOR PRR-42 RAI (PRR-42 Rev. 1)

2.6.2 Several of the coverage sketches included in ultrasonic reports for Examination

Category B-J circumferential piping welds are unclear. For example, the sketch shown for Weld 10-1A-14 lists only a 70-degree longitudinal examination; however, the calibration report indicates that both a 45-degree shear and a 70-degree longitudinal technique were used. For those welds under a conventional ISI program, please re-submit cross-sectional sketches, or full written descriptions, describing ASME Code-required volumes and areas of completed coverage for each of the techniques used on these welds. Summarize the scanning directions and techniques, list the materials for the base metal and weld, and clarify whether the methods used have been qualified in accordance with performance demonstration requirements per ASME Section XI, Appendix VIII.

2.6.2 RESPONSE:

Total ultrasonic examination coverage of welds 10-1A-14, 10-1A-15, 10R-1A-6, 10R-1A-7, 12-O-24, 14-A-19, 14-B-17, 14-B-20, 1-SD-10R, 2R-HB-1 and 2R-HB-4 is impractical due to obstructions or limiting component configuration that adversely affects the scan paths for required ultrasonic beam projections required to achieve complete coverage.

Welds 10-1A-14 and 10-1A-15

Weld 10-1A-14 is a Residual Heat Removal (RHR) System stainless steel pipe to stainless steel flued head penetration weld utilizing stainless steel weld metal. Weld 10-1A-15 is a Residual Heat Removal (RHR) System stainless steel pipe to stainless steel valve weld utilizing stainless steel weld metal. These welds are essentially constructed identically, differing only in the degree of weld surface preparation/contour and in this case utilize the same ultrasonic system calibration.

These welds were ultrasonically examined manually utilizing Entergy Nuclear Procedure ENN-NDE-9.23, Revision 0. This procedure is the equivalent of EPRI PDI generic procedure PDI-UT-2 which meets the requirements of ASME Section XI, Appendix VIII, Supplement 2 for ultrasonic examination of austenitic piping welds. Refer to Report CDS No. 05-C-450.

Manual scanning was performed from the pipe side of these welds only. Scanning was performed in both the transverse (scanning transverse or perpendicular to the weld) and parallel (scanning parallel to the weld in both the clockwise and counter clockwise directions). Page 2 of Data Sheets EDS No. 05-E-451-ISI and 05-E-452-ISI of Report No. CDS No. 05-C-450 contains a sketch that depicts the ASME Code required volume (inner 1/3 thickness extending for 1/4" beyond the toe of the weld). In addition, this sketch depicts the scanning direction and coverage for a 70° refracted longitudinal wave beam.

Procedure ENN-NDE-9.23 paragraph 5.3.6.1 states "Search units designed to produce nominal inspection angles of 45°, 60° or 70° shall be used. The actual angle produced in austenitic material shall be used for technique selection, coverage calculations, and plotting of all indications. All the previously required angles are nominal with a deviation allowance of $\pm 3^\circ$." Further, paragraph 5.3.7.2.1.3 states, "When accessibility is limited to a single side in materials greater than 0.50" thick, a longitudinal wave search unit that provides adequate coverage on the far side of the weld shall be used for the detection and length sizing of flaws on the far side of the weld." In the case of welds 10-1A-14 and 10-1A-15, the examiner conservatively utilized two angles and modes of propagation for the greatest achievable coverage. The 45° shear wave was utilized for pipe side coverage and the 70° longitudinal wave for total coverage. Only the 70° longitudinal wave is portrayed on the sketch to demonstrate complete procedure required coverage on both sides of the weld.

RESPONSES FOR PRR-42 RAI (PRR-42 Rev. 1)

Examination coverage is limited on these welds due to the pipe to component configurations. Qualified examination coverage could only be claimed for the base material and weld heat affected zone on the pipe side. Procedure ENN-NDE-9.23 paragraph 1.81 states, "Detection of length sizing of circumferentially oriented flaw indications when only single side access is available and the flaw is located on the far side of the weld, however guidance is provided. The techniques identified in this procedure have been demonstrated to be representative of "best effort" technology for single side detection of far side defects parallel to the weld." This condition resulted in claimed examination coverage for these welds as follows: 14-A-10A, 50% code coverage and 14-B-10A, 50% code coverage.

Welds 10R-1A-6 and 10R-1A-7

Welds 10R-1A-6 and 10R-1A-7 are Residual Heat Removal (RHR) System stainless steel pipe to stainless steel valve welds utilizing stainless steel weld metal. These welds are essentially constructed identically, differing only in the degree of weld surface preparation/contour and in this case utilize the same ultrasonic system calibration.

These welds were ultrasonically examined manually utilizing Procedure 50.87, Revision 1. This procedure is the equivalent of EPRI PDI generic procedure PDI-UT-2 which meets the requirements of ASME Section XI, Appendix VIII, Supplement 2 for ultrasonic examination of austenitic piping welds. Refer to Report Nos. CDS 03-C-135 and 03-C-137.

Manual scanning was performed from the pipe side of these welds only. Scanning was performed in both the transverse (scanning transverse or perpendicular to the weld) and parallel (scanning parallel to the weld in both the clockwise and counter clockwise directions). Page 2 of Data Sheets EDS No. 03-E-136 and 03-E-138 of Report Nos. CDS 03-C-135 and 03-C-137 contain a sketch that depicts geometric reflector plotting. The Code required volume for inspection of these welds is the inner 1/3 thickness extending for 1/4" beyond the toe of the weld. Coverage for these welds can only be claimed from one side due to the pipe to valve configuration. Procedure 50.87, Revision 1, paragraph 1.4 states in part, "Where access to both sides is not possible, this procedure is qualified for detection of circumferentially oriented flaws from one side of the weld. This procedure is not qualified for the detection of axially oriented flaws or length sizing of any flaw located on the far side of the weld when performing single side access examinations." Therefore, these weld examinations met the single side access requirements of the procedure and thus only 50% Code required volume inspection coverage was achievable for welds 10R-1A-6 and 10R-1A-7.

Weld 12-O-24

Weld 12-O-24 is a Reactor Water Cleanup (RWCU) System stainless steel pipe to stainless steel flued head weld utilizing stainless steel weld metal.

This weld was ultrasonically examined manually utilizing Procedure 50.87, Revision 0. This procedure is the equivalent of EPRI PDI generic procedure PDI-UT-2 which meets the requirements of ASME Section XI, Appendix VIII, Supplement 2 for ultrasonic examination of austenitic piping welds. Refer to Report No. CDS 01-C-316.

Manual scanning was performed from the pipe side of this weld only. Scanning was performed in both the transverse (scanning transverse or perpendicular to the weld) and parallel (scanning parallel to the weld in both the clockwise and counter clockwise directions). Page 2 of Data Sheets EDS No. 01-E-317 of Report No. CDS 01-C-316 contains a sketch that depicts the ASME Code required volume (inner 1/3 thickness extending for 1/4" beyond the toe of the weld). In addition, this sketch depicts the scanning direction and coverage for the 45° and 70° shear wave beams.

RESPONSES FOR PRR-42 RAI (PRR-42 Rev. 1)

Procedure 50.87, Revision 0, paragraph 1.4 states in part, "Where access to both sides is not possible, this procedure is qualified for detection of circumferentially oriented flaws from one side of the weld. This procedure is not qualified for the detection of axially oriented flaws or length sizing of any flaw located on the far side of the weld when performing single side access examinations." Paragraph 4.1.8 of this procedure states in part, "Search unit wedges that produce a nominal angle of 45° shall be used when the examination volume can be effectively covered in two directions. When geometric configuration(s) prohibit full coverage with the 45° search unit a 60° search unit shall be selected. When geometric configurations prohibit coverage with the 45° and 60° search unit, a 70° search unit shall be selected." Page 2 of Data Sheets EDS No. 01-E-317 of Report No. CDS 01-C-316 contains a sketch that depicts the scanning direction and coverage for the 45° and 70° shear wave beams. Since this is single sided examination coverage, greater than 50% of the required examination volume cannot be claimed and therefore the coverage should be revised to 50% not the stated 56.64%.

Weld 14-A-19

Weld 14-A-19 is a Core Spray (CS) System stainless steel pipe to stainless steel valve weld utilizing stainless steel weld metal. Refer to Report CDS No. 05-C-457-ISI.

This weld was ultrasonically examined manually utilizing Entergy Nuclear Procedure ENN-NDE-9.23, Revision 0. This procedure is the equivalent of EPRI PDI generic procedure PDI-UT-2 which meets the requirements of ASME Section XI, Appendix VIII, Supplement 2 for ultrasonic examination of austenitic piping welds.

Manual scanning was performed from the pipe side of this weld only. Scanning was performed in both the transverse (scanning transverse or perpendicular to the weld) and parallel (scanning parallel to the weld in both the clockwise and counter clockwise directions). Page 2 of Data Sheet No. 05-E-458-ISI contains a sketch that depicts the ASME Code required volume (inner 1/3 thickness extending for ¼" beyond the toe of the weld). In addition, this sketch depicts the scanning direction and coverage for both 45° shear wave and a 70° refracted longitudinal wave beam.

Procedure ENN-NDE-9.23 paragraph 5.3.6.1 states "Search units designed to produce nominal inspection angles of 45°, 60° or 70° shall be used. The actual angle produced in austenitic material shall be used for technique selection, coverage calculations, and plotting of all indications. All the previously required angles are nominal with a deviation allowance of $\pm 3^\circ$." Further, paragraph 5.3.7.2.1.3 states, "When accessibility is limited to a single side in materials greater than 0.50" thick, a longitudinal wave search unit that provides adequate coverage on the far side of the weld shall be used for the detection and length sizing of flaws on the far side of the weld." In the case of weld 14-A-19, the examiner conservatively utilized two angles and modes of propagation for the greatest achievable coverage. The 45° shear wave was utilized for pipe side coverage and the 70° longitudinal wave for total coverage. Only the 70° longitudinal wave is portrayed on the sketch to demonstrate complete procedure required coverage on both sides of the weld. Because the weld contour is flat enough to scan across the entire weld surface, the coverage sketch depicted on Page 2 of Data Sheet No. 05-E-458-ISI indicates the projected beams on both sides of the weld even though coverage can only be claimed for one side.

Examination coverage is limited on this weld due to the pipe to valve configuration. Qualified examination coverage could only be claimed for the base material and weld heat affected zone on the pipe side. Procedure ENN-NDE-9.23 paragraph 1.81 states, "Detection of length sizing of circumferentially oriented flaw indications when only single side access is available and the flaw is located on the far side of the weld, however guidance is provided. The techniques identified in this procedure have been demonstrated to be representative of "best effort" technology for single side detection of far side defects parallel to the weld." This condition resulted in claimed examination coverage for these welds as follows: 14-A-19 50% code coverage.

RESPONSES FOR PRR-42 RAI (PRR-42 Rev. 1)

Welds 14-B-17 and 14-B-20

Welds 14-B-17 and 14-B-20 are Core Spray (CS) System stainless steel pipe to stainless steel penetration fitting welds utilizing stainless steel weld metal. These welds are essentially constructed identically, differing only in the degree of weld surface preparation/contour and in this case utilize the same ultrasonic system calibration. Refer to Report No. CDS 01-C-193.

These welds were ultrasonically examined manually utilizing Procedure ITI 50.87, Revision 0. This procedure is the equivalent of EPRI PDI generic procedure PDI-UT-2 which meets the requirements of ASME Section XI, Appendix VIII, Supplement 2 for ultrasonic examination of austenitic piping welds. Refer to Report No. CDS 01-C-193.

Manual scanning was performed from the pipe side of these welds only. Scanning was performed in both the transverse (scanning transverse or perpendicular to the weld) and parallel (scanning parallel to the weld in both the clockwise and counter clockwise directions). Pages 3 and 4 of Data Sheets LDS No. 01-L-141 of Report No. CDS 01-C-193 contains a sketch that depicts the coverage projections for the 45° shear wave and 60° refracted longitudinal wave. The Code required volume for inspection of these welds is the inner 1/3 thickness extending for ¼" beyond the toe of the weld. Coverage for these welds can only be claimed from one side due to the pipe to penetration fitting configuration. Procedure 50.87, Revision 0, paragraph 1.4 states in part, "Where access to both sides is not possible, this procedure is qualified for detection of circumferentially oriented flaws from one side of the weld. This procedure is not qualified for the detection of axially oriented flaws or length sizing of any flaw located on the far side of the weld when performing single side access examinations." Therefore, these weld examinations met the single side access requirements of the procedure and thus only 50% Code required volume inspection coverage was achievable for welds 14-B-17 and 14-B-20. Since this is single sided examination coverage, greater than 50% of the required examination volume cannot be claimed and therefore the coverage should be revised to 50% for both welds not the stated 58.7% for weld 14-B-17 and 59.42% for weld 14-B-20.

Weld 1-SD-10R

Weld 1-SD-10R is a Main Steam (MS) System carbon steel pipe to valve weld utilizing carbon steel weld metal. Refer to Report CDS No. 01-C-252.

This weld was ultrasonically examined manually utilizing Procedure ITI 50.71, Revision 5. This procedure is the equivalent of EPRI PDI generic procedure PDI-UT-01 which meets the requirements of ASME Section XI, Appendix VIII, Supplement 3 for ultrasonic examination of ferritic piping welds.

Manual scanning was performed from the pipe side of these welds only. Scanning was performed in both the transverse (scanning transverse or perpendicular to the weld) and parallel (scanning parallel to the weld in both the clockwise and counter clockwise directions). Page 2 of Data Sheet EDS No. 01-E-253 of Report No. CDS No. 01-C-252 contains a sketch that depicts the ASME Code required volume (inner 1/3 thickness extending for ¼" beyond the toe of the weld). In addition, this sketch depicts the scanning direction and coverage for 45° and 70° shear wave.

Paragraph 4.1.8 of procedure ITI 50.71, Revision 5 states in part, "Search unit wedges that produce a nominal angle of 45° shall be used when the examination volume can be effectively covered in two directions. When geometric configuration(s) prohibit full coverage with the 45° search unit a 60° search unit shall be selected. When geometric configurations prohibit coverage with the 45° and 60° search unit, a 70° search unit shall be selected." Page 2 of Data Sheets EDS No. 01-E-317 of Report No. CDS 01-C-316 contains a sketch that depicts the scanning

RESPONSES FOR PRR-42 RAI (PRR-42 Rev. 1)

direction and coverage for the 45° and 70° shear wave beams. In this case 100% axial scan coverage was achieved but only 75% circumferential coverage due to the downstream weld to valve profile causing transducer "lift-off." The resultant composite coverage for weld 1-SD-10R is 87.5%.

Welds 2R-HB-1 and 2R-HB-4

Welds 2R-HB-1 and 2R-HB-4 are Reactor Recirculation System 316 stainless steel pipe to 316 stainless steel pipe welds utilizing stainless steel weld metal. These welds are essentially constructed identically, differing only in the degree of weld surface preparation/contour and in this case utilize the same ultrasonic system calibration. Refer to Report Nos. CDS 01-C-155 and 01-C-157.

These welds were ultrasonically examined manually utilizing Procedure ITI 50.87, Revision 0. This procedure is the equivalent of EPRI PDI generic procedure PDI-UT-2 which meets the requirements of ASME Section XI, Appendix VIII, Supplement 2 for ultrasonic examination of austenitic piping welds. Refer to Report Nos. CDS 01-C-155 and 01-C-157.

Manual scanning was performed from the pipe side of these welds only. Scanning was performed in both the transverse (scanning transverse or perpendicular to the weld) and parallel (scanning parallel to the weld in both the clockwise and counter clockwise directions). Page 2 and 3 of Data Sheet EDS No. 01-E-156 and page 3 of Data Sheet EDS No. 01-E-158 of Report Nos. CDS 01-C-155 and 01-C-157 contains a sketch that depicts the Code required volume for inspection of these welds is the inner 1/3 thickness extending for 1/4" beyond the toe of the weld and the projected scans for the 45° shear, 60° shear wave and 60° refracted longitudinal wave beams.

Procedure ITI 50.87, Revision 0, paragraph 1.4 states in part, "Where access to both sides is not possible, this procedure is qualified for detection of circumferentially oriented flaws from one side of the weld. This procedure is not qualified for the detection of axially oriented flaws or length sizing of any flaw located on the far side of the weld when performing single side access examinations." Therefore, these weld examinations were performed utilizing the single side access requirements of the procedure and thus only 50% Code required volume inspection coverage can be claimed for welds 2R-HB-1 and 2R-HB-4. Since this is single sided examination coverage, greater than 50% of the required examination volume cannot be claimed and therefore the coverage should be revised to 50% for both welds not the stated 75%.

At the time these examinations were conducted, it was believed by the inspector that these welds were configured as a pipe to reducer and they were only scanned from the downstream side of the welds. In fact, these welds are a unique pipe to larger pipe configuration and could potentially be scanned from both sides. PNPS will evaluate scanning from both sides of these welds which should yield inspection coverage of > 90%. These welds are currently scheduled for re-examination in the 4th ISI Interval.

RESPONSES FOR PRR-42 RAI (PRR-42 Rev. 1)

2.7.1 *The licensee elected to perform liquid penetrant examination of the subject control rod drive (CRD) housing welds, as shown by examination reports on pages 218 and 219 of the submittal. However, no sketches indicating the exact cause of the limited examinations are provided. In addition, it is unclear whether the licensee has completed the ASME Code-required 10% of peripheral CRD housing welds by the examinations that were performed.*

Confirm that the four CRD housing welds submitted in PRR-42 represent 10% of the peripheral CRD housing welds on the RPV at PNPS. Alternatively, discuss whether other peripheral CRD housing welds could be examined to compensate for the limited coverage on the subject welds in order to complete the ASME Code-required 10% surface areas.

2.7.1 RESPONSE:

The 1989 ASME Section XI Code, Category B-O, Examination Item B14.10, requires a volumetric or surface examination of 10% of the peripheral CRD housings during the 3rd Interval.

The control rod drive housings are inserted through the control rod drive penetrations in the reactor vessel bottom head and are welded to the Inconel stub tubes extending into the reactor vessel. The housings are fabricated of type 304 austenitic stainless steel. (Refer to Attachment E for a schematic of the CRD housings undervessel.)

PNPS elected to perform a surface examination at 4 locations using the liquid penetrant method during RFO#15 (ref. exam reports 05-P-432-ISI and 05-P-433-ISI). Due to accessibility issues, the surface examinations of the four selected locations were limited to 50%-70% of the weld areas. The undervessel area is congested with horizontal beams, hanger rods, support bars, grids, etc. severely limiting access in this area and the available work space. This and the proximity of adjacent CRD drives accounted for the limited examinations in this area.

Attachment E shows that there are 36 peripheral CRD housings with 2 assembly welds per housing. 10% of 36 peripheral housings rounds up to 4 housings per Interval requiring inspection. The four CRD housing examinations submitted in PRR-42 (ref. exam reports 05-P-432-ISI and 05-P-433-ISI) represent ~11% of the peripheral CRD housings at PNPS.

The net surface examination coverage obtained on the 4 housings that were inspected was approximately 60%. Even though this was performed on >10% of the required housings, the net surface examined still accounts for less than 100% of the Code-required coverage.

To account for the limited surface examination coverage obtained during the 3rd Interval inspections, Entergy will be revising the ISI Program to select additional CRD housings for examination during the 4th Interval in order to be certain that an equivalent 100% inspection of 10% of the peripheral housings is obtained. Assuming an average 55% coverage per housing, examination of 3 additional housings (7 total) will provide the equivalent code required coverage. This will satisfy the examination requirements of the 1998 ASME Code Section XI / 2000 Addenda which is utilized for the 4th Interval.

RESPONSES FOR PRR-42 RAI (PRR-42 Rev. 1)

2.8.1 Please list the applicable component (vessel, piping, pump, or valve) and system for each of the subject welded attachments:

EB-23-13HL1(4) EB-23-59HL1(4) HL-10-200HL1(4)

2.8.1 RESPONSE:

The applicable component (vessel, piping, pump, or valve) and system for each of the subject welded attachments is as follows:

EXAM POINT	SYSTEM	DRAWING	COMPONENT TYPE	CAT.	ITEM NO.
EB-23-13HL1(4)	HPCI	ISI-I-23-2	PIPING WELDED ATTACHMENT	C-C	C3.20
EB-23-59HL1(4)	HPCI	ISI-I-23-2	PIPING WELDED ATTACHMENT	C-C	C3.20
HL-10-200HL1(4)	RHR	ISI-I-10- 4ASH1	PIPING WELDED ATTACHMENT	C-C	C3.20

RESPONSES FOR PRR-42 RAI (PRR-42 Rev. 1)

2.9.1 *There are several discrepancies with the licensee-submitted examination reports for pipe-to-valve Weld GB-14-F34 which affect this evaluation.*

1) *On the Calibration Data Sheet (page 224) a 70-degree refracted longitudinal technique is shown, but on the cross-sectional coverage sketch (page 226) both 60- and 70-degree examinations are indicated. Please confirm the ultrasonic techniques used for examining this weld, and confirm these methods have been qualified by performance demonstration in accordance with ASME Section XI, Appendix VIII. In addition, in the remarks section of this calibration sheet, it is stated that the weld was "scanned below reference due to high noise levels." Further explain the cause of this excessive noise, and state whether scanning below reference level has been successfully demonstrated via Appendix VIII.*

3) *The licensee reports relatively low volumetric coverage (approximately 30%) for Weld GB-14-F34. From the coverage sketch sheets and remarks (pages 226, 227, and 228), it is unclear which examination techniques produced portions of the cumulative coverage. Please re-submit cross-sectional sketches, or full written descriptions, describing ASME Code-required volumes and areas of completed coverage for each of the techniques used on this weld.*

4) *From the remarks on the sketch sheet on page 228, it appears that the outside surface geometry and/or weld crown was not in compliance with the licensee's ultrasonic procedure ENN-NDE-9.10, and displayed surface roughness, or gaps, that exceeded 1/32-inch which significantly impacted the ultrasonic examination. Discuss the surface smoothness criteria, as stated in the procedure, and whether the surface conditions on Weld GB-14-F34 prevented the methods qualified through performance demonstration per ASME Section XI, Appendix VIII to be effective on the subject weld.*

2.9.1 1), 2.9.1 3), and 2.9.1 4) RESPONSES:

Total ultrasonic examination coverage of weld GB-14-F34 is impractical due to obstructions or limiting component configuration that adversely affects the scan paths for required ultrasonic beam projections required to achieve complete coverage.

Weld GB-14-F34 is a Category C-F-1 Core Spray (CS) System carbon steel pipe to stainless steel valve weld utilizing stainless steel weld metal having a nominal wall thickness of 0.432". Refer to Report CDS No. 05-C-492-ISI and Attachment D.

This weld was ultrasonically examined manually utilizing Entergy Nuclear Procedure ENN-NDE-9.10, Revision 0. This procedure is the equivalent of EPRI PDI generic procedure PDI-UT-10 which meets the requirements of ASME Section XI, Appendix VIII, Supplement 10 for ultrasonic examination of dissimilar metal piping welds.

Manual scanning was performed from the pipe side of this weld only. Scanning was performed in both the transverse (scanning transverse or perpendicular to the weld) and parallel (scanning parallel to the weld in both the clockwise and counter clockwise directions). Page 2 of Data Sheet No. 05-E-493-ISI contains a sketch that depicts the ASME Code required volume (inner 1/3 thickness extending for 1/4" beyond the toe of the weld). In addition, this sketch depicts the scanning direction and coverage for both 60° and a 70° shear wave beams.

Entergy Nuclear Procedure ENN-NDE-9.10, Revision 0, Section 5.4 required that dissimilar metal welds having thickness < 0.50" be scanned in the axial direction with 60° and 70° shear and longitudinal beams and 45 ° shear and longitudinal beams in the circumferential direction. The sketch identified above depicts the maximum forward movement for the shear wave transducers

RESPONSES FOR PRR-42 RAI (PRR-42 Rev. 1)

which was the most limiting aspect of this examination. Coverage calculations are based on transducer positions prior to lifting off the component due to weld crown configuration. Page 4 of Data Sheet 05-E-493-ISI presents the calculation for a total Code required volume coverage of 29.75%. It should also be noted that ENN-NDE-9.10, Revision 0, paragraph 1.0[8] does not allow scanning from the cast stainless steel side of a weld, therefore no scanning could be performed from the valve side even if the physical profile was acceptable.

RESPONSES FOR PRR-42 RAI (PRR-42 Rev. 1)

2.9.1 *There are several discrepancies with the licensee-submitted examination reports for pipe-to-valve Weld GB-14-F34 which affect this evaluation.*

2) The Examination Data Sheet (page 225) shows the component materials to be both carbon steel and stainless steel. List the materials for the base metals and weld, clarify if any Alloy 600/82/182 or stainless steel buttering exists, and if so, discuss whether ultrasonic techniques qualified for dissimilar metal welds should be used for Weld GB-14-F34.

2.9.1 2) RESPONSE:

Weld GB-14-F34 is a pipe-to-valve weld in the Class 2 portion of the Core Spray system with carbon steel pipe welded to the stainless steel valve body of motor-operated valve MO1400-4B. This weld is original plant construction, made in January 1972, and consists of Schedule 40 A106 Gr B carbon steel pipe welded to an A182 F316 forged stainless steel valve body using E309 weld filler metal. No Inconel weld metal or stainless steel buttering was used to make this weld. This weld is not exposed to reactor coolant as it is a Class 2 weld with normal service conditions of 80 degrees F and 300 psig in accordance with Entergy piping specification M-300. Operating temperatures for this weld are well below the accepted IGSCC initiation temperature of 200F as detailed in Generic Letter 88-01 and NUREG 0313. Consequently, IGSCC is not considered to be a potential degradation mechanism for this location. As such, ultrasonic techniques qualified for examining dissimilar metal welds are not applicable to this weld.

This weld has been scheduled to be radiographed during Pilgrim's 2009 refueling outage in accordance with the 1998-2000 addenda ASME Section XI code volumetric inspection requirements in lieu of ultrasonic methods due to the pipe-to-valve configuration which caused UT examination coverage results obtained during the 3rd interval to be less than required.

RESPONSES FOR PRR-42 RAI (PRR-42 Rev. 1)

2.9.3 State the population of other Examination Category C-F-1 welds that were completed to the full extent of ASME Code requirements.

2.9.3 RESPONSE:

There are twelve Category C-F-1 welds installed at PNPS including welds with wall thickness less than 0.375 inches (i.e. thin-wall). Eleven of the twelve C-F-1 welds were volumetrically examined during the 3rd interval with ten welds achieving documented coverage greater than 90%. Limited coverage was obtained for weld GB-14-F34 and weld GB-14-F33 was not examined as discussed below.

All twelve welds are located in portions of Class 2 standby systems (RHR and Core Spray) that are not exposed to reactor coolant and experience service conditions with normal operating temperatures of 80 degrees F in accordance with Entergy piping specification M-300. IGSCC is not considered as a damage mechanism for austenitic stainless steel welds with normal operating temperatures less than 200 degrees F as documented in Generic Letter 88-01. Correspondingly, these welds are not subject to the requirements of Generic Letter 88-01.

Four of the twelve C-F-1 welds were constructed with nominal pipe wall thickness less than 0.375 inches (0.280 in.). Examination of thin-wall (<0.375 in.) butt welds was not required by the 1989 ASME XI code Table IWC-2500-1 requirements. However, the four thin-wall C-F-1 welds at PNPS were subsequently scheduled for ultrasonic examination during the 3rd interval as part of an augmented sample requested by the regulator. As discussed above, three of the four augmented welds were examined with ultrasonic techniques. Two of these four augmented welds obtained greater than 90% coverage during examinations in 1997 with the examination of a third augmented weld (GB-14-F34) producing limited coverage (as discussed in response to RAI question 2.9.1). The fourth augmented weld (weld no. GB-14-F33) could not be examined during the 3rd interval since the original plant configuration (see photo) is a stainless steel valve-to-carbon steel flange weld that does not allow examination with ultrasonic methods. This weld is scheduled to be volumetrically examined using radiographic methods during the 2009 refueling outage in lieu of ultrasonic techniques in order to obtain the code-required volumetric coverage.

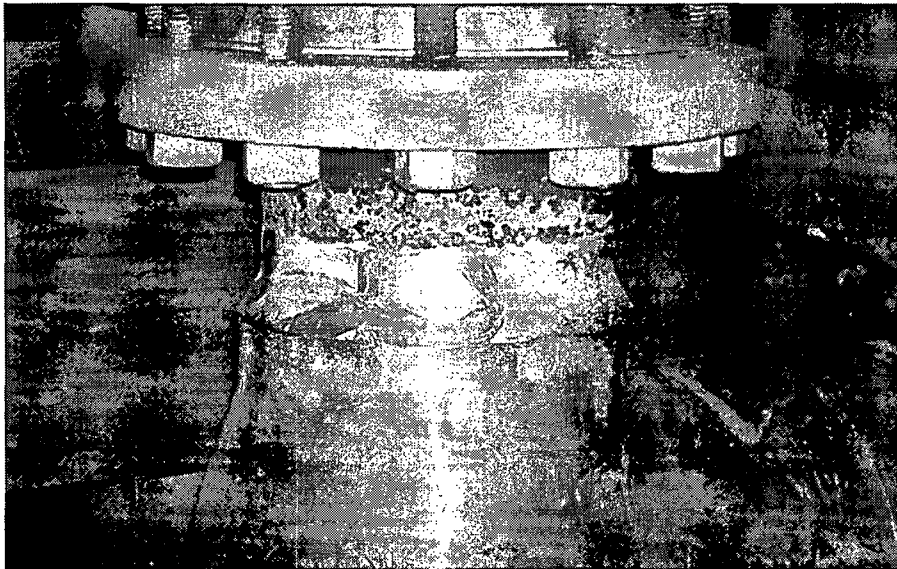

GB-14-F33

RESPONSES FOR PRR-42 RAI (PRR-42 Rev. 1)

2.9.4 *State whether 100% of the ASME Code-required surface examination was completed on Weld GB-14-F34.*

2.9.4 RESPONSE:

100% of the required surface examination was completed.

RESPONSES FOR PRR-42 RAI (PRR-42 Rev. 1)

2.10.1 *The licensee has shown 85% surface examination coverage obtained for Weld GB-10-9-2E, using the magnetic particle (MT) examination method. The sketch (page 230) shows a bolted pipe hanger clamp as being the cause of the obstruction to this MT examination. Discuss whether the examination coverage could be increased by use of other surface methods, e.g., liquid penetrant. Also, state the population of other Examination Category C-F-2 welds that were completed (surface and volumetric) to the full extent of the ASME Code requirements.*

2.10.1 RESPONSE:

There are a total of 1003 category C-F-2 welds at PNPS including those with wall thickness less than 0.375 inches (i.e. thin-wall). The category C-F-2 inspection sample consists of 82 welds that were examined with surface and volumetric techniques during the 3rd ten-year inspection interval. Acceptable (>90%) code coverage was obtained for 80 of the 82 welds in the inspection sample. The two welds where less than the required coverage was obtained are GB-10-9-2E and HE-26-F238, both of which are discussed in detail in this submittal.

The magnetic particle (MT) surface examination of weld GB-10-9-2E (ref. datasheet 03-M-064) yielded a combined coverage of 85% due to a large pipe clamp obstructing access to portions of the weld inspection boundary. As shown in Figure IWC-2500-7 of ASME XI, the surface examination inspection boundary includes the weld surface plus the pipe surface out to a distance of ½ inch from each weld toe. To achieve acceptable coverage, greater than 90% of this surface area must be examined.

The use of other surface examination methods such as liquid penetrant (PT) have been evaluated for the purpose of increasing coverage for this weld. The configuration of weld GB-10-9-2E consists of a vertical 12 inch diameter weldolet (16.9 inch diameter) joined to a horizontal 18 inch diameter carbon steel pipe. No known degradation mechanism affects this weld due to being fabricated entirely of carbon steel materials and the standby operating status of this Class 2 system (RHR) eliminates fatigue as a potential failure mechanism. A heavy-duty 3-bolt 18 inch pipe clamp, a component part of pipe support H-10-1-81, is located on the downstream side of the welded pipe intersection and butts directly against the downstream toe of weld GB-10-9-2E. The pipe clamp is 4.5 inches wide and 0.875 inches thick. The horizontal centerline of the 18 inch horizontal pipe and the associated pipe clamp is 29 feet above the Torus Room floor. For the clamp to be loosened and slid upstream far enough to provide unobstructed access to weld GB-10-9-2E, cribbing or other supports would have to be installed to temporarily support the pipe. Due to the remote location of this pipe support in the ceiling of the Torus Room, no practical means exists to temporarily support this pipe so the clamp can be loosened and moved or completely removed to provide increased inspection access to weld GB-10-9-2E.

The MT examination performed in 2003 reported that an arc length of 8 circumferential inches of weld and adjacent pipe surfaces was obstructed by the adjacent pipe clamp. It is estimated that an additional 2 inches (1 inch at each end of the 8 inch obstructed region) of weld and vertical (12 in.) pipe surface might be gained by the use of PT methods as opposed to the original MT method. No additional coverage however is possible on the horizontal (18 in.) pipe surface due to the pipe clamp obstruction. This 2 inches of potential added coverage on the vertical pipe surface using PT methods adds only approximately 1.5% to the combined coverage, raising the total coverage to only 86.5%. To obtain greater than 90% coverage for this weld, more than 3 inches of additional coverage would need to be examined on both the vertical and horizontal pipe surfaces, an outcome which is not possible without moving the pipe clamp. For these reasons, it is concluded that the use of alternate surface examination methods for weld GB-10-9-2E in order to obtain the required >90% coverage would not be successful.

RESPONSES FOR PRR-42 RAI (PRR-42 Rev. 1)

2.10.2 *In addition, the licensee has reported 63.8% volumetric coverage for Weld GB-10-9-2E, which is described as a "weldolet", and a cross-sectional sketch is included on page 233. However, from this sketch, Weld GB-10-9-2E appears to be a branch connection (Item C5.81) configuration similar to that shown in ASME Figure IWC-2500- 12. As such, only a surface examination is required to be performed on this weld. Please confirm whether this weld is a full penetration circumferential butt weld, or a branch connection, as shown in the licensee-submitted sketch.*

2.10.2 RESPONSE:

The configuration of weld GB-10-9-2E consists of a vertical 12-inch diameter weldolet (16.9-inch diameter) joining line 12"-GB-10 to a horizontal 18-inch diameter carbon steel pipe (line no. 18"-GB-10) in the RHR System. This configuration is depicted on drawing ISI-I-10-4B Sheet 1 and is a branch connection using a circumferential full penetration fillet weld to connect the weldolet to the 18" diameter run pipe, similar to Figure IWC-2500-10. As such, this weld should have been classified as Examination Category C-F-2 Item No. C5.81 instead of Item No. C5.51. The required examination method for this weld is surface only per Table IWC-2500-1. The last inspection of this weld consisted of both surface (MT) and volumetric (UT) examinations.

The station's ISI tracking database has been updated to reflect Code Item No. C5.81 as being the correct classification for this weld. Any future examinations at this location will consist of the MT surface examination method only. As stated in the response to RAI Question 2.10.1, the last magnetic particle (MT) surface examination of this weld (reference datasheet 03-M-064) yielded a combined coverage of 85% due to a large pipe clamp obstructing access to portions of the weld inspection boundary. The use of the PT (liquid penetrant) method does not provide an appreciable gain in the 90% required coverage. Due to the remote location of the obstructing pipe support in the ceiling of the Torus Room, no practical means exists to temporarily support this pipe so that the clamp can be loosened and moved, or completely removed, to provide increased inspection access to weld GB-10-9-2E. As such, future MT surface examinations are expected to average 85% coverage only.

RESPONSES FOR PRR-42 RAI (PRR-42 Rev. 1)

2.10.3 *If Weld GB-10-9-2E requires a volumetric examination, discuss whether the coverage could be increased by performing scans from the "branch pipe" side of the weld.*

2.10.3 RESPONSE:

Total ultrasonic examination coverage of weld GB-10-9-2E is impractical due to obstructions or limiting component configuration that adversely affects the scan paths for required ultrasonic beam projections required to achieve complete coverage.

Weld GB-10-9-2E is a Residual Heat Removal (RHR) System carbon steel pipe to fitting (weldolet) branch connection weld utilizing carbon steel weld metal. Refer to Report CDS No. 03-C-072.

This weld was ultrasonically examined manually utilizing Procedure ITI 50.71, Revision 6. This procedure is the equivalent of EPRI PDI generic procedure PDI-UT-01 which meets the requirements of ASME Section XI, Appendix VIII, Supplement 3 for ultrasonic examination of ferritic piping welds.

After review of NRC comments regarding this weld, PNPS agrees that a possibility exists that additional ultrasonic coverage may be possible. In view of this fact, PNPS has rescheduled this weld for ultrasonic examination in the upcoming refueling outage (RFO-17). Based on the sketch from the above referenced UT report it appears that additional UT coverage can be achieved by scanning from the fitting side. It should be noted however that > 90% coverage may not be achieved due to the adjacent pipe support clamp that cannot be removed due to function and location. Further, given that all Category C-F-2 branch connections are required to be examined, there are no additional branch connections remaining to supplement the required sample.

RESPONSES FOR PRR-42 RAI (PRR-42 Rev. 1)

2.10.4 *Weld HE-26-F238 is listed as a valve-to-pipe configuration. However, from the cross-sectional coverage sketch (page 236), it appears that scans could be performed from both sides of this weld. Please confirm the ultrasonic techniques used for examining this weld, and confirm these methods have been qualified by performance demonstration in accordance with ASME Section XI, Appendix VIII. In addition, state whether the surface examination was completed to the full extent of ASME Code requirements for Weld HE-26-F238.*

2.10.4 RESPONSE:

Total ultrasonic examination coverage of weld HE-26-F238 is impractical due to obstructions or limiting component configuration that adversely affects the scan paths for required ultrasonic beam projections required to achieve complete coverage.

Weld HE-26-F238 is a Category C-F-2 Reactor Core Isolation Cooling (RCIC) System carbon steel pipe to valve weld utilizing carbon steel weld metal. Refer to Report CDS No. 05-C-338-ISI.

This weld was ultrasonically examined manually utilizing Entergy Nuclear Procedure ENN-NDE-9.04, Revision 1. This procedure is the equivalent of EPRI PDI generic procedure PDI-UT-01 which meets the requirements of ASME Section XI, Appendix VIII, Supplement 3 for ultrasonic examination of ferritic piping welds.

This weld was examined in the third ISI Interval as part of an NRC directed augmented inspection requirement of thin wall (<0.375") piping welds since these welds were not required to be examined under the 1989 Edition of ASME Section XI, Category C-F-2 selection criteria. The PNPS fourth Interval ISI Program Plan basis is the 1998 Edition though 2000 Addenda of ASME Section XI. As a result of this upgrade, this weld is included in the total required count of Category C-F-2 welds, but was not selected as part of the required examination population percentage. Given this fact, PNPS believes that no further action is required for this weld.

RESPONSES FOR PRR-42 RAI (PRR-42 Rev. 1)

2.10.5 *List the system(s) on which Welds GB-10-9-2E and HE-26-F238 exist.*

2.10.5 RESPONSE:

GB-10-9-2E is in the RHR System as shown on Drawing ISI-I-10-4B Sheet 1.

For ISI purposes, HE-26-F238 is considered to be in the RCIC System as shown on Drawing ISI-I-13-5. This component is in the RCIC Pump suction (condensate transfer) line from the Condensate Storage Tank (CST).

RESPONSES FOR PRR-42 RAI (PRR-42 Rev. 1)

**TABLE 3 (UPDATED)
COMPONENTS WITH LESS THAN "ESSENTIALLY 100%" COVERAGE**

CODE CATEGORY	CODE ITEM	COMPONENT ID	DESCRIPTION	COMBINED NDE COVERAGE		LIMITATION (CAUSE OF REDUCED COVERAGE)
				MT/PT	UT	
B-A	B1.21	RPV-BH-C1	HEAD CIRCUMF. WELD	---	75	VESSEL SKIRT CONFIGURATION AND THERMOCOUPLES
B-A	B1.12	RPV-L-1-338A	LOWER INTERMEDIATE SHELL VERTICAL WELD	---	89	JET PUMP RISER SUPPORT INTERFERENCE
B-A	B1.12	RPV-L-1-338C	LOWER INTERMEDIATE SHELL VERTICAL WELD	---	25	JET PUMP RISER SUPPORT, SURV. SPECIMEN HOLDER & SUPPORT BRACKETS, SHROUD REPAIR TIE ROD INTERFERENCE
B-A	B1.12	RPV-L-2-338A	LOWER SHELL VERTICAL WELD	---	73	BAFFLE PLATE AND BAFFLE GUSSET INTERFERENCE
B-A	B1.12	RPV-L-2-338B	LOWER SHELL VERTICAL WELD	---	78	BAFFLE PLATE GUSSET INTERFERENCE
B-A	B1.12	RPV-L-2-338C	LOWER SHELL VERTICAL WELD	---	25	BAFFLE PLATE, GUSSET, SHROUD REPAIR TIE ROD INTERFERENCE, N2K NOZZLE
B-A	B1.12	RPV-L-2-339A	UPPER INTERMEDIATE SHELL VERTICAL WELD	---	81	FW AND CS SPARGER INTERFERENCE
B-A	B1.12	RPV-L-2-339B	UPPER INTERMEDIATE SHELL VERTICAL WELD	---	75	FW AND CS SPARGER INTERFERENCE AND ID TAPER
B-A	B1.12	RPV-L-2-339C	UPPER INTERMEDIATE SHELL VERTICAL WELD	---	83	FW AND CS SPARGER INTERFERENCE
B-A	B1.30	RPV-SF-0-120	SHELL TO FLANGE	---	81	N3 NOZZLES, NOZZLE PLUGS, GUIDE RODS @ 0 & 180 deg, FLANGE CONFIGURATION
B-A	B1.30	RPV-SF-120-240	SHELL TO FLANGE	---	81	N3 NOZZLES, NOZZLE PLUGS, GUIDE RODS @ 0 & 180 deg, FLANGE CONFIGURATION
B-A	B1.30	RPV-SF-240-360	SHELL TO FLANGE	---	81	N3 NOZZLES, NOZZLE PLUGS, GUIDE RODS @ 0 & 180 deg, FLANGE CONFIG.
B-D	B3.90	RPV-N7A-NV	NOZZLE TO VESSEL	---	56.7	NOZZLE CONFIGURATION
B-D	B3.90	RPV-N7B-NV	NOZZLE TO VESSEL	---	56.7	NOZZLE CONFIGURATION
B-D	B3.90	RPV-N8-NV	NOZZLE TO VESSEL	---	70.6	NOZZLE CONFIGURATION
B-F	R1.20 (B5.130)	14-A-10A	VALVE TO PIPE	---	37.1	PIPE TO VALVE WELD PROFILE
B-F	R1.20 (B5.130)	14-B-10A	VALVE TO PIPE	---	22.1	PIPE TO VALVE WELD PROFILE

RESPONSES FOR PRR-42 RAI (PRR-42 Rev. 1)

**TABLE 3 (UPDATED)
COMPONENTS WITH LESS THAN "ESSENTIALLY 100%" COVERAGE**

CODE CATEGORY	CODE ITEM	COMPONENT ID	DESCRIPTION	COMBINED NDE COVERAGE		LIMITATION (CAUSE OF REDUCED COVERAGE)
				MT/PT	UT	
B-F	R1.20 (B5.10)	2R-N1B-1	NOZZLE TO SAFE END	---	75	REDUCED COVERAGE ON CIRC. SCANS DUE TO SURFACE CONTOUR AND MIN. WALL ISSUES
B-F	R1.20 (B5.10)	2R-N2E-1	SAFE END TO NOZZLE	---	81.2	REDUCED COVERAGE ON CIRC. SCANS DUE TO SURFACE CONTOUR AND MIN. WALL ISSUES
B-F	R1.20 (B5.10)	2R-N2G-1	SAFE END TO NOZZLE	---	75.3	REDUCED COVERAGE ON CIRC. SCANS DUE TO SURFACE CONTOUR AND MIN. WALL ISSUES
B-F	R1.20 (B5.10)	2R-N2J-1	SAFE END TO NOZZLE	---	75	REDUCED COVERAGE ON CIRC. SCANS DUE TO SURFACE CONTOUR AND MIN. WALL ISSUES
B-F	R1.11 (B5.10)	6-N4A-1	SAFE END TO NOZZLE	---	87.5	REDUCED COVERAGE DUE TO WELDED THERMOCOUPLE PADS
B-F	R1.11 (B5.10)	6-N4B-1	SAFE END TO NOZZLE	---	87.5	REDUCED COVERAGE DUE TO WELDED THERMOCOUPLE PADS
B-F	R1.11 (B5.10)	6-N4C-1	SAFE END TO NOZZLE	---	88.6	REDUCED COVERAGE DUE TO WELDED THERMOCOUPLE PADS
B-F	R1.11 (B5.10)	6-N4D-1	SAFE END TO NOZZLE	---	88.6	REDUCED COVERAGE DUE TO WELDED THERMOCOUPLE PADS
B-H	B8.10	RPV-SBW-0	RPV STABILIZER WELD	50	---	ONLY UPPER SURFACE ACCESSIBLE
B-J	R1.20 (B9.11)	10-IA-14	PIPE TO FLUED HEAD	---	50	PIPE TO PENETRATION FLUED HEAD CONFIGURATION
B-J	R1.20 (B9.11)	10-IA-15	PIPE TO VALVE	---	50	PIPE TO VALVE WELD PROFILE
B-J	R1.11 (B9.11)	10R-IA-6	PIPE TO VALVE	---	50	PIPE TO VALVE WELD PROFILE
B-J	R1.11 (B9.11)	10R-IA-7	VALVE TO PIPE	---	50	PIPE TO VALVE WELD PROFILE
B-J	R1.20 (B9.11)	12-O-24	PENETRATION TO PIPE	---	50	PENETRATION FLUED HEAD TO PIPE CONFIGURATION
B-J	R1.20 (B9.11)	14-A-19	PIPE TO VALVE	---	50	PIPE TO VALVE WELD PROFILE
B-J	R1.20 (B9.11)	14-B-17	PIPE TO PENETRATION	---	50	PIPE TO PENETRATION FLUED HEAD CONFIGURATION
B-J	R1.20 (B9.11)	14-B-20	PIPE TO PIPE	---	50	WALL OBSTRUCTION
B-J	R1.11 (B9.21)	1-SD-10R	PIPE TO VALVE	---	87.5	PIPE TO VALVE WELD PROFILE
B-J	R1.20 (B9.11)	2R-HB-1	HEADER TO BEND	---	50	REDUCER TO PIPE CONFIGURATION

RESPONSES FOR PRR-42 RAI (PRR-42 Rev. 1)

**TABLE 3 (UPDATED)
COMPONENTS WITH LESS THAN "ESSENTIALLY 100%" COVERAGE**

CODE CATEGORY	CODE ITEM	COMPONENT ID	DESCRIPTION	COMBINED NDE COVERAGE		LIMITATION (CAUSE OF REDUCED COVERAGE)
				MT/PT	UT	
B-J	R1.20 (B9.11)	2R-HB-4	HEADER TO BEND	---	50	REDUCER TO PIPE CONFIGURATION
B-O	B14.10	RPV-CRD-HSG-1	CRD HOUSING WELD	70	---	LIMITED EXAM DUE TO ADJACENT DRIVES; DRIVES CHOSEN TO MAXIMIZE COVERAGE; SHOOTOUT STEEL REMOVED FOR EXAM.
B-O	B14.10	RPV-CRD-HSG-2	CRD HOUSING WELD	50	---	LIMITED EXAM DUE TO ADJACENT DRIVES; DRIVES CHOSEN TO MAXIMIZE COVERAGE; SHOOTOUT STEEL REMOVED FOR EXAM.
B-O	B14.10	RPV-CRD-HSG-3	CRD HOUSING WELD	50	---	LIMITED EXAM DUE TO ADJACENT DRIVES; DRIVES CHOSEN TO MAXIMIZE COVERAGE; SHOOTOUT STEEL REMOVED FOR EXAM.
B-O	B14.10	RPV-CRD-HSG-4	CRD HOUSING WELD	65	---	LIMITED EXAM DUE TO ADJACENT DRIVES; DRIVES CHOSEN TO MAXIMIZE COVERAGE; SHOOTOUT STEEL REMOVED FOR EXAM.
C-C	C3.20	EB-23-13HL1(4)	SUPPORT LUGS	87.5	---	HANGER CLAMP AGAINST 1 SIDE OF LUG
C-C	C3.20	EB-23-59HL1(4)	SUPPORT LUGS	83.3	---	HANGER CLAMP AGAINST 1 SIDE OF LUG
C-C	C3.20	HL-10-200HL1(4)	SUPPORT LUGS	90	---	HANGER CLAMP AGAINST 1 SIDE OF LUG
C-F-1	C5.11	GB-14-F34	PIPE TO VALVE	---	29.8	PIPE-TO VALVE WELD PROFILE
C-F-2	C5.51	GB-10-9-2E	WELDOLET	85	63.8	PIPE CLAMP OBSTRUCTION
C-F-2	C5.51	HE-26-F238	VALVE TO PIPE	---	68.8	ONE-SIDED EXAM DUE TO VALVE

Sketch 1

Pilgrim Weld RPV-BH-C1

60° NS Exam Volume = 5.3 Sq. In.
 60° FV Exam Volume = 16.2 Sq. In.
 60° Inner 15% Exam Volume = 3.0 Sq. In.

60° NS T-Scan achieved = 3.9 Sq. In.
 60° FV T-Scan achieved = 14.4 Sq. In.
 60° Inner 15% T-Scan achieved = 2.5 Sq. In.

60° P-Scan achieved = 3.2 Sq. In.
 60° FV P-Scan achieved = 9.9 Sq. In.
 60° Inner 15% P-Scan achieved = 2.0 Sq. In.

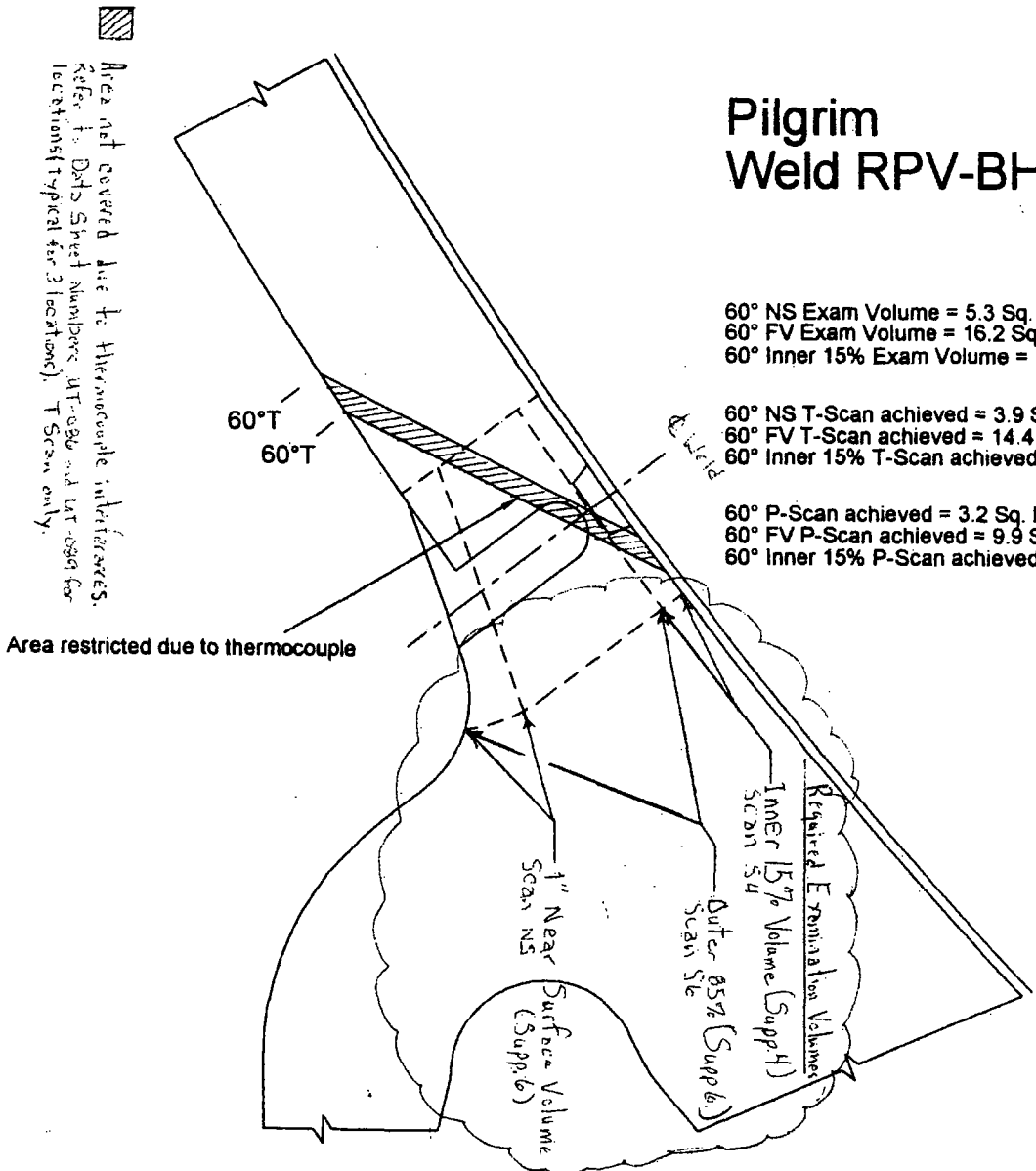

Area not covered due to thermocouple interferences.
 Refer to Data Sheet Number: UT-089 and UT-089A for locations typical for 3 locations). T-Scan only.

Pilgrim RF015, 2005

Handwritten signature
 UT-089 5-4-05

Sketch 2

Pilgrim Weld RPV-BH-C1

60° NS Exam Volume = 5.3 Sq. In.
 60° FV Exam Volume = 16.2 Sq. In.
 60° Inner 15% Exam Volume = 3.0 Sq. In.

60° NS T-Scan achieved = 3.9 Sq. In.
 60° FV T-Scan achieved = 16.1 Sq. In.
 60° Inner 15% T-Scan achieved = 3.0 Sq. In.

60° P-Scan achieved = 3.2 Sq. In.
 60° FV P-Scan achieved = 9.9 Sq. In.
 60° Inner 15% P-Scan achieved = 2.0 Sq. In.

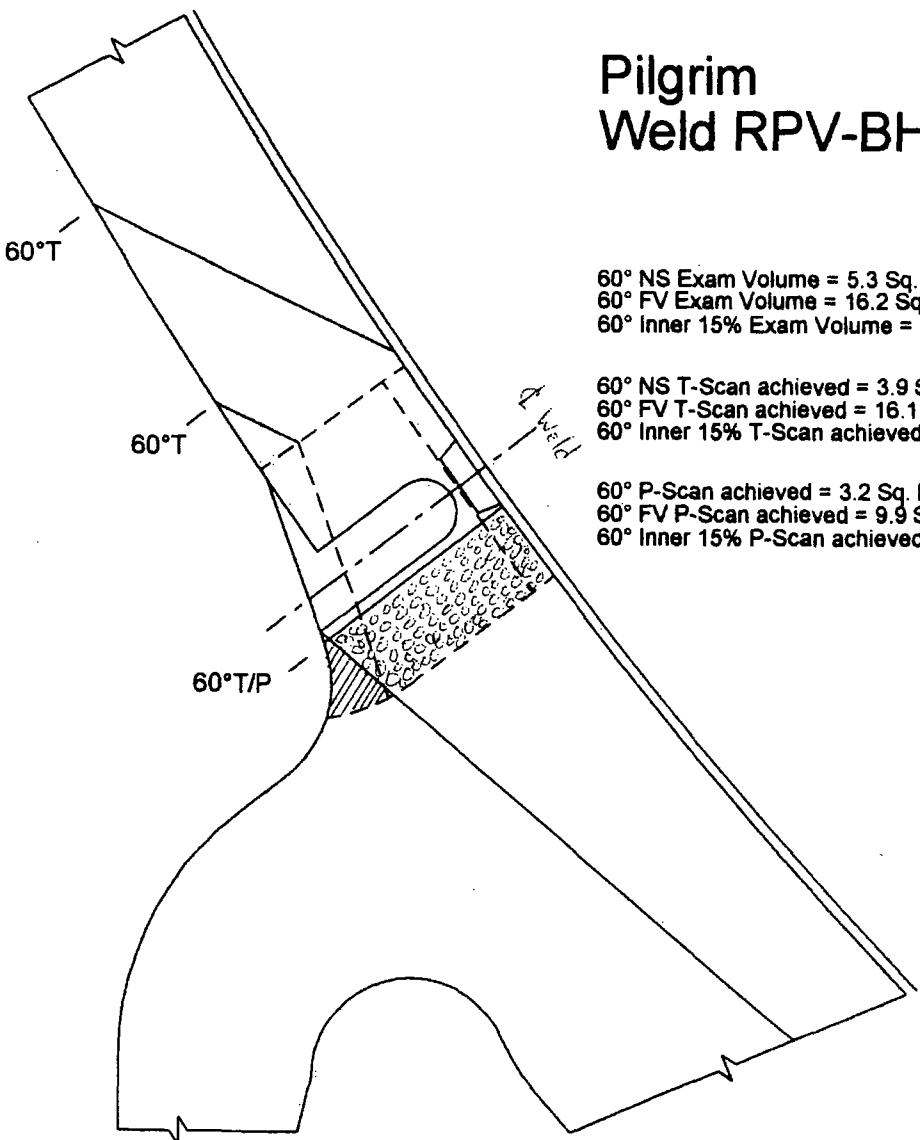

Area not covered by the T scan



Area not covered by either the T or P scans

Pilgrim RF015, 2005



Page 12 of 12

*Sketch 2
 11/11/05 5:4:05*

Scan 78
 2-11-05
 Page 8 of 8

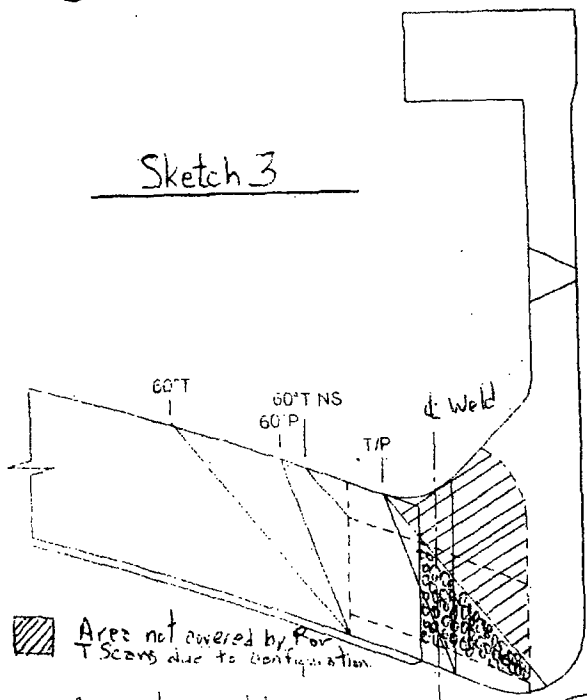
Sketch 3



 Area not covered by T Scans due to configuration.
 Area not covered by P Scan due to configuration.

Nozzle Top Side

60° NS Exam Volume = 10.2 Sq. In.
 60° FV Exam Volume = 14.7 Sq. In.
 Inner 15% T Exam Volume = 3.1 Sq. In.

 60° NS T-Scan achieved = 1.7 Sq. In.
 60° FV T-Scan achieved = 11.3 Sq. In.
 60° Inner 15% T-Scan achieved = 3.1 Sq. In.

 Scan Plan Coverage T and P scans
 60° NS P-Scan achieved = 1.3 Sq. In.
 60° FV P-Scan achieved = 5.9 Sq. In.
 60° Inner 15% P-Scan achieved = 3.1 Sq. In.

Pilgrim ^{-N7A&B}
 Weld RPV ~~N7A-NV~~
 Top Head Spray

Nozzle Bottom Side

60° NS Exam Volume = 10.2 Sq. In.
 60° FV Exam Volume = 14.7 Sq. In.
 Inner 15% T Exam Volume = 3.1 Sq. In.

 60° NS T-Scan achieved = 1.7 Sq. In.
 60° FV T-Scan achieved = 11.3 Sq. In.
 60° Inner 15% T-Scan achieved = 3.1 Sq. In.

 60° NS P-Scan achieved = 1.3 Sq. In.
 60° FV P-Scan achieved = 5.9 Sq. In.
 60° Inner 15% P-Scan achieved = 3.1 Sq. In.

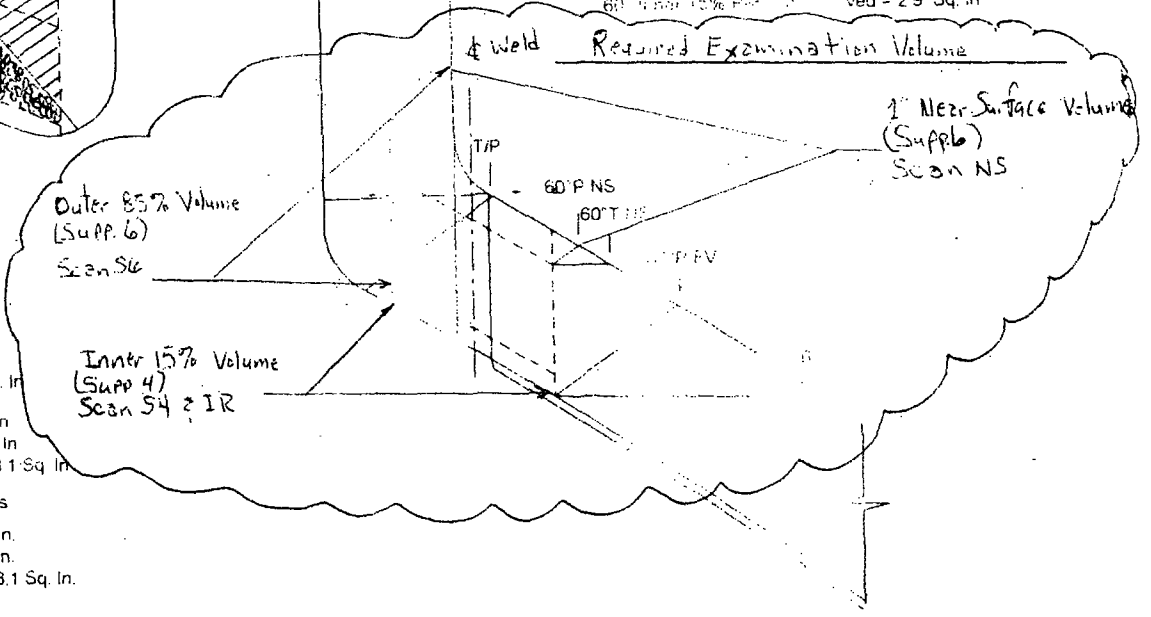

Pilgrim Weld RPV-N8-NV Top Head Vent



60° NS Exam Volume = 8.2 Sq. In.
 60° FV Exam Volume = 13.8 Sq. In.
 60° Inner 15% Exam Volume = 3.3 Sq. In.

60° NS T-Scan achieved = 3.5 Sq. In.
 60° FV T-Scan achieved = 13.4 Sq. In.
 60° Inner 15% T-Scan achieved = 3.3 Sq. In.

60° NS P-Scan achieved = 2.9 Sq. In.
 60° FV P-Scan achieved = 9.3 Sq. In.
 60° Inner 15% P-Scan achieved = 3.3 Sq. In.

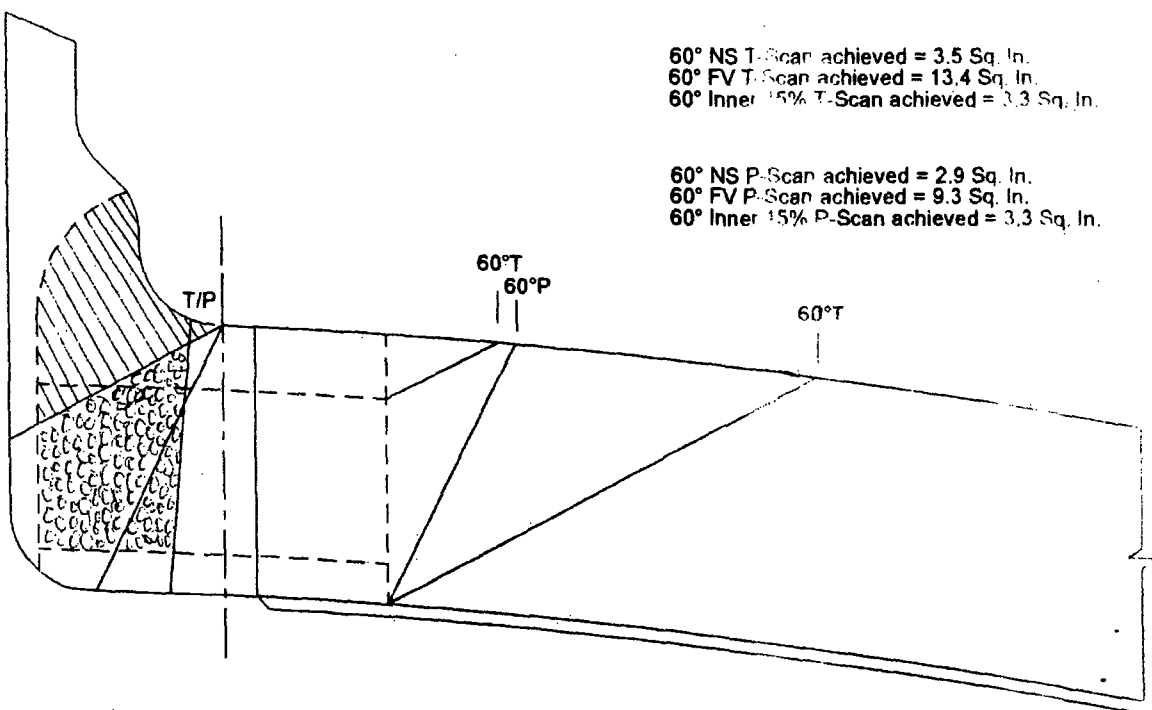
Sketch 4



-  Area not covered by Per T Scans due to configuration
-  Area not covered by P Scan due to configuration

Note: The required examination volumes are as shown for non-bleed vessel configuration on sketch 3.

RESPONSES FOR PRR-42 RAI (PRR-42 Rev. 1)
Attachment B – Response to RAI 2.2.3



IHI Southwest Technologies
NDE Examination Services

Pilgrim Nuclear Power Station
April 2005 – RFO15

Positional location of the AIRIS scanner is accomplished using a combination of measurements integrated and displayed by the control system. An origin reference point is established for each examination zone by locating a specific elevation and azimuth. Elevation can be determined by the use of two high-accuracy water depth sensors, one on the device and one located at a fixed location such as the vessel flange, or it can be determined visually by driving the device to a fixed component inside the vessel whose elevation is known. Azimuth reference location can be accomplished

using optical beam transmitter/receiver system to determine azimuth location based on the known location of internal reactor components, or a physical reference can be obtained from other components such as sparger piping, steam dryer lugs, surveillance specimen holders, or guide rod brackets.

Once the device is on the vessel wall in the referenced position, the encoded drive wheels provide travel distance and a gravity sensor keeps track of device orientation. The control unit integrates this information and provides constant positional information relative to the device location. A graphic display unit also shows the orientation of the device and direction of movement.

The device is controlled through a single umbilical cable bundle, which contains all inputs and outputs to the control system as well as the AUT transducer cables. This device control cable also contains a steel braided cable so that the cable can also function as a device retrieval mechanism in the unlikely event of a power failure or thrust propeller failure. Device operation is monitored visually during the inspections using independent remote video cameras.

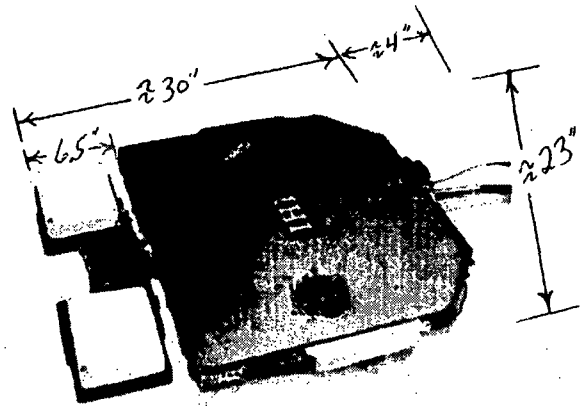

Scanner is ≈ 2 " thick

Figure 2. AIRIS-21 Scanner

RESPONSES FOR PRR-42 RAI (PRR-42 Rev. 1)
Attachment B – Response to RAI 2.2.3



IHI Southwest Technologies
NDE Examination Services

Pilgrim Nuclear Power Station
April 2005 – RFO15

2.3 NDE Techniques

The RPV vertical welds were ultrasonically examined utilizing ISwT's Performance Demonstration Initiative (PDI) qualified detection procedures. These procedures were previously qualified for both double-sided and single-sided detection and sizing using SLIC40 and Duplex transducer designs.

For flaw detection on the inner 3.25" of the vessel wall (which includes the Supplement 4 volume), SLIC 40 search unit are used for the detection of both parallel and transverse flaws. When scanning can be accomplished from both sides, two opposing SLIC 40 transducers are used. When scanning can only be accomplished from one side, two SLIC 40s are used side by side.

For flaw detection on the outer portion of the vessel shell, ISwT's "Duplex" transducers were used. These specially designed transducers significantly improve signal-to-noise ratios over standard transducers and were especially valuable during the Supplement 6 qualification for discrimination of buried flaws in the "mid-wall" region of the shell. Two Duplex 55-degree transducers are used in opposing directions when scanning was accomplished from two sides. When scanning can only be accomplished from one side, two Duplex transducers are again used in the same direction, however, one is a 45-degree Duplex. This approach again allows retention of the "two-hit" criterion, but provides a slightly different angle for more reliable flaw confirmation.

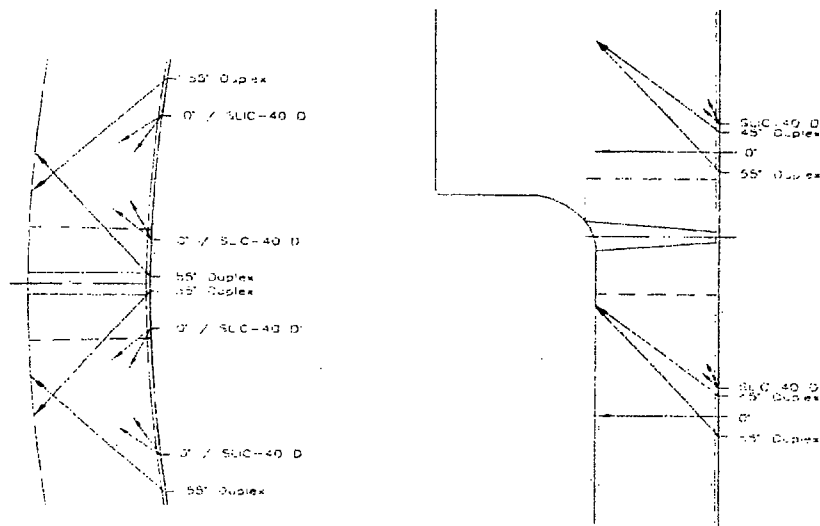
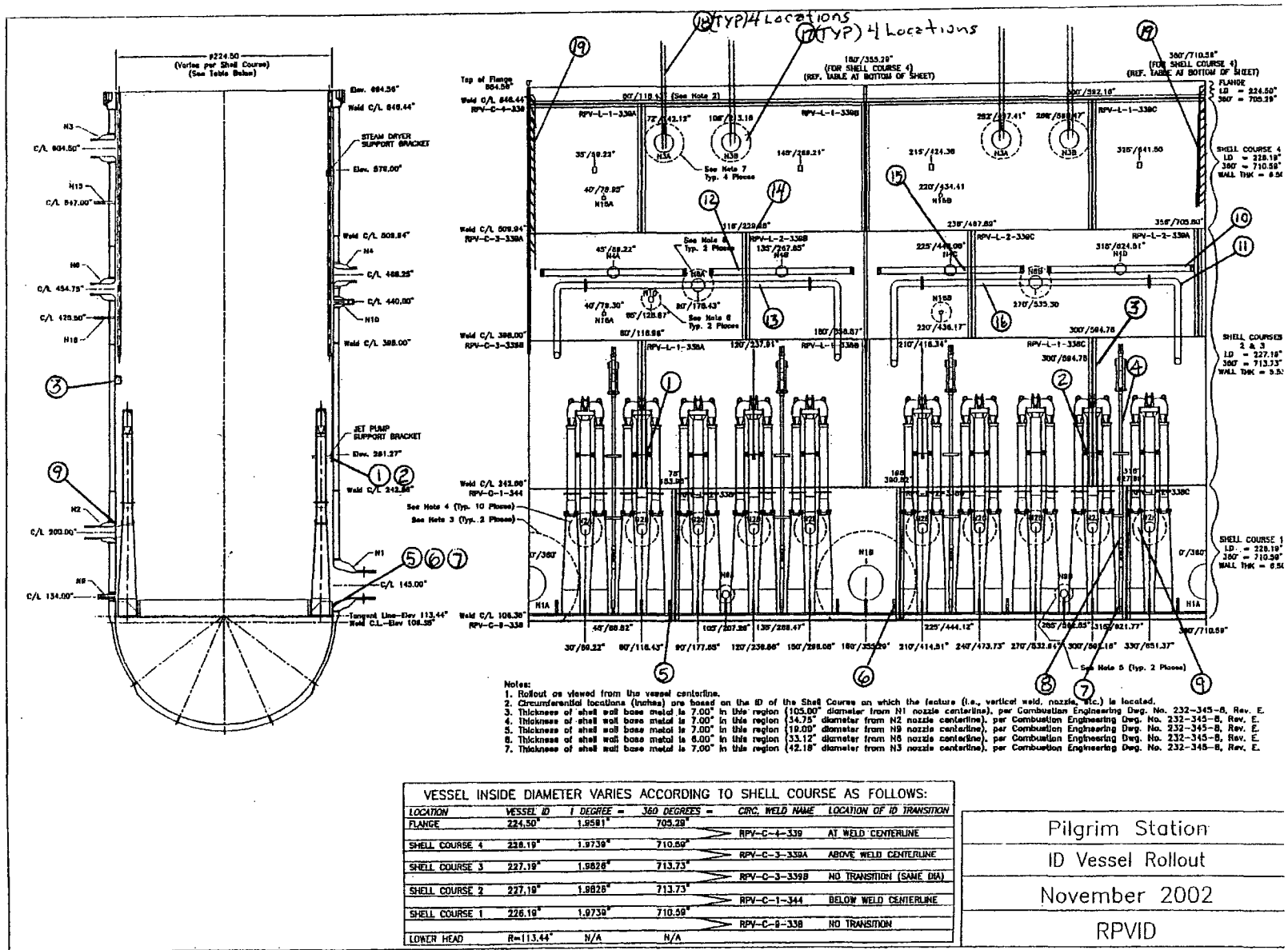

Figure 4. PDI Detection Techniques for RPV



VESSEL INSIDE DIAMETER VARIES ACCORDING TO SHELL COURSE AS FOLLOWS:				
LOCATION	VESSEL ID	1 DEGREE =	360 DEGREES =	CIRC. WELD NAME LOCATION OF ID TRANSITION
FLANGE	224.50"	1.9581"	705.28"	RPV-C-4-339 AT WELD CENTERLINE
SHELL COURSE 4	228.19"	1.9739"	710.59"	RPV-C-3-338A ABOVE WELD CENTERLINE
SHELL COURSE 3	227.19"	1.9828"	713.73"	RPV-C-3-339B NO TRANSITION (SAME DIA)
SHELL COURSE 2	227.19"	1.9828"	713.73"	RPV-C-1-344 BELOW WELD CENTERLINE
SHELL COURSE 1	228.19"	1.9739"	710.59"	RPV-C-8-338 NO TRANSITION
LOWER HEAD	R=113.44"	N/A	N/A	

Pilgrim Station
 ID Vessel Rollout
 November 2002
 RPVID

RESPONSES FOR PRR-42 RAI (PRR-42 Rev. 1)
 Attachment C - Response to RAI 2.2.3: RPV Rollout

RESPONSES FOR PRR-42 RAI (PRR-42 Rev. 1)
Attachment C – Response to RAI 2.2.3: RPV Rollout

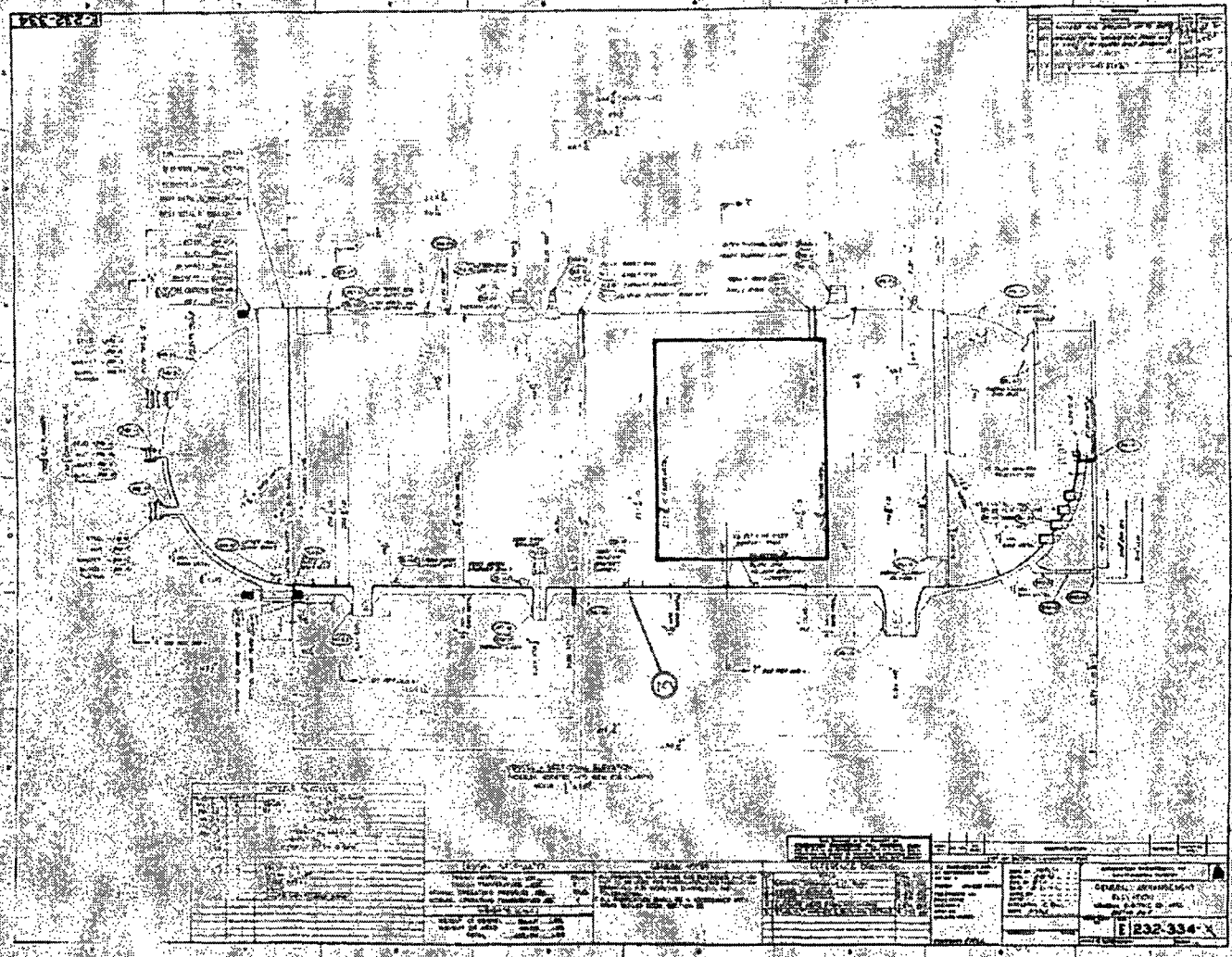

0
MIA 28-3
-0



Calibration Data Sheet

CDS No: 05-C-377-151
 LDS No: 05-L-378-151 ^{4/21} _{7/10/05}
 Page: 1 of 4 ^{pages}

Plant/Unit: PILGRIM / 1
 System: CORE SPRAY
 Component: GB-14-F34
 Line No.: 6"-GB-14
 Procedure: ENP-NDE-9.10 Rev.: 0
 Thermometer S/N: 232
 Cal. Blk Temp.: 63°F Comp Temp.: 64°F
 Cal. Block No.: PIL-39A
 Carbon Steel Stainless Steel
 Size: 6" Sch.: .280"
 Cal Direction Axial Circ Both
 Scan Area ⊥ to weld
 Scan Area || to weld

Work Order: 03116642
 DWG No.: ISI I 14-2B

Cal Checks	Time
Initial Cal.:	<u>1000</u>
Date:	<u>4-25-05</u>
Inter. Cal.:	
Date:	
Inter. Cal.:	
Date:	
Final Cal.:	<u>1609</u>
Date:	<u>4-25-05</u>

Couplant
 Type: ULTRAGEL II
 Batch: 01225

Examination Area / Weld	Access	Recordable Indications			Exam Sens.
		Yes	No	Geom.	
<u>GB-14-F34</u>	<u>SINGLE</u>	<u>N/A</u>	<u>✓</u>	<u>N/A</u>	<u>SD.4</u>

Remarks
N/A

Further Evaluation Required: Yes No

Examiner: [Signature] Level: III Date: 4-25-05
 Examiner: N/A Level: N/A Date: N/A
 Reviewer: [Signature] Level: II Date: 4/27/05
 ANII: [Signature] Date: 3/2/05

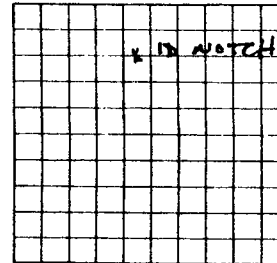

Search Unit # 1

Manufacturer: KBA
 Model: COMP-G
 Serial No.: 00582L
 Size: .25" Shape: Round
 Freq.: 2.25MHz Elm: 1
 Angle: 45° Mode: SHEAR
 Measured Angle: 45°
 Wedge Style: MSWQC

Search Unit Cable

Type: RG 174
 Length: 6' # Con.: Ø

Instrument Settings

Manufacturer: STAVELEY
 Model: SONIC 136
 Serial No.: 136-875K
 Linearity Due: 5-2-05
 Delay: 206 Range: 1.00
 Mtl. Vel.: 124 Pulser: 222
 Damping: 500 Reject: OFF
 Rep Rate: 4K Freq.: 2.25
 Filter: 2 Mode: P-E

Reference Sensitivity

Axial: N/A Circ: 44.4

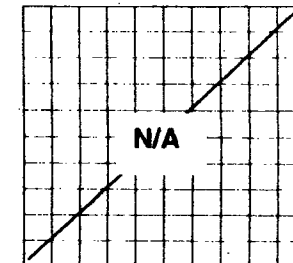

Search Unit # 2

Manufacturer: _____
 Model: _____
 Serial No.: _____
 Size: _____ Shape: _____
 Freq.: _____ # Elm: _____
 Angle: _____ Mode: _____
 Measured Angle: _____
 Wedge Style: _____

Search Unit Cable

Type: _____
 Length: _____ # Con.: _____

Instrument Settings

Manufacturer: N/A
 Model: _____
 Serial No.: _____
 Linearity Due: _____
 Delay: _____ Range: _____
 Mtl. Vel.: _____ Pulser: _____
 Damping: _____ Reject: _____
 Rep Rate: _____ Freq.: _____
 Filter: _____ Mode: _____

Reference Sensitivity

Axial: _____ Circ: _____



Calibration Data Sheet

CDS No: 05-C-374-151 ⁴⁹²

LDS No: 05-L-228-14491-151 ⁷⁰⁰

Page: 3 of 4 ^{4/10}

Plant/Unit: PILGRIM / 1
 System: CORE SPRAY
 Component: GB-14-F34
 Line No.: 6"-GB-14
 Procedure: ENP-NDE-9.10 Rev.: 0
 Thermometer S/N: 232
 Cal. Blk Temp.: 63°F Comp Temp.: 64°F
 Cal. Block No.: PIL-96
 Carbon Steel Stainless Steel
 Size: 6" Sch.: .432"

Work Order: 03116642
 DWG No.: ISI I 14-2B

Cal Checks	Time
Initial Cal.:	<u>0910/0925</u>
Date:	<u>4-25-05</u>
Inter. Cal.:	
Date:	
Inter. Cal.:	
Date:	
Final Cal.:	<u>1555/1558</u>
Date:	<u>4-25-05</u>

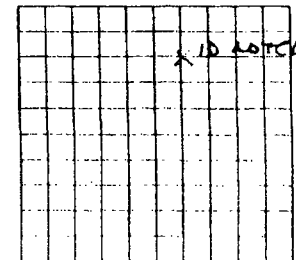
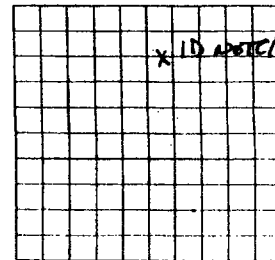

Cal Direction Axial Circ Both

Scan Area I to weld

Scan Area II to weld

Couplant
 Type: ULTRAGEL II
 Batch: 01225

Search Unit # 1
 Manufacturer: RTD
 Model: TRLA
 Serial No.: 98-978
 Size: 2(7x10) Shape: RECT
 Freq.: 2 MHz # Elm: 2
 Angle: 45° Mode: LONG
 Measured Angle: 45
 Wedge Style: INTEGRAL

Search Unit # 2
 Manufacturer: RTD
 Model: TRLA
 Serial No.: 98-979
 Size: 2(7x10) Shape: RECT
 Freq.: 2 MHz # Elm: 2
 Angle: 60° Mode: LONG
 Measured Angle: 60°
 Wedge Style: INTEGRAL

Search Unit Cable
 Type: RG 174
 Length: 6' # Con.: 0

Search Unit Cable
 Type: RG 174
 Length: 6' # Con.: 0

Instrument Settings
 Manufacturer: STAVELEY
 Model: SONIC 136
 Serial No.: 136-875K
 Linearity Due: 5-2-05
 Delay: .786 Range: 1.00
 Mtl. Vel.: .232 Pulsar: 250
 Damping: 500 Reject: OFF
 Rep Rate: 4K Freq.: 2.25
 Filter: 2 Mode: DUAL

Instrument Settings
 Manufacturer: STAVELEY
 Model: SONIC 136
 Serial No.: 136-875K
 Linearity Due: 5-2-05
 Delay: .917 Range: 1.25
 Mtl. Vel.: .235 Pulsar: 250
 Damping: 500 Reject: OFF
 Rep Rate: 4K Freq.: 2.25
 Filter: 2 Mode: DUAL

Reference Sensitivity
 Axial: N/A Circ: 64.6

Reference Sensitivity
 Axial: 70.6 Circ: N/A

Examination Area / Weld	Access	Recordable Indications			Exam Sens.
		Yes	No	Geom.	
<u>GB-14-F34</u>	<u>SINGLE</u>	<u>N/A</u>	<u>✓</u>	<u>N/A</u>	<u>64.6 / 64.6*</u>

Remarks:
 * SCANNED BELOW REFERENCE DUE TO HIGH NOISE LEVELS.

Further Evaluation Required: Yes No

Examiner: [Signature] Level: III Date: 4-25-05
 Examiner: N/A Level: N/A Date: N/A
 Reviewer: [Signature] Level: III Date: 4/27/05
 ANII: [Signature] Date: 5/2/05

RESPONSES FOR PRR-42 RAI (PRR-42 Rev. 1)
Attachment E – Response to RAI 2.7.1: CRD Housings

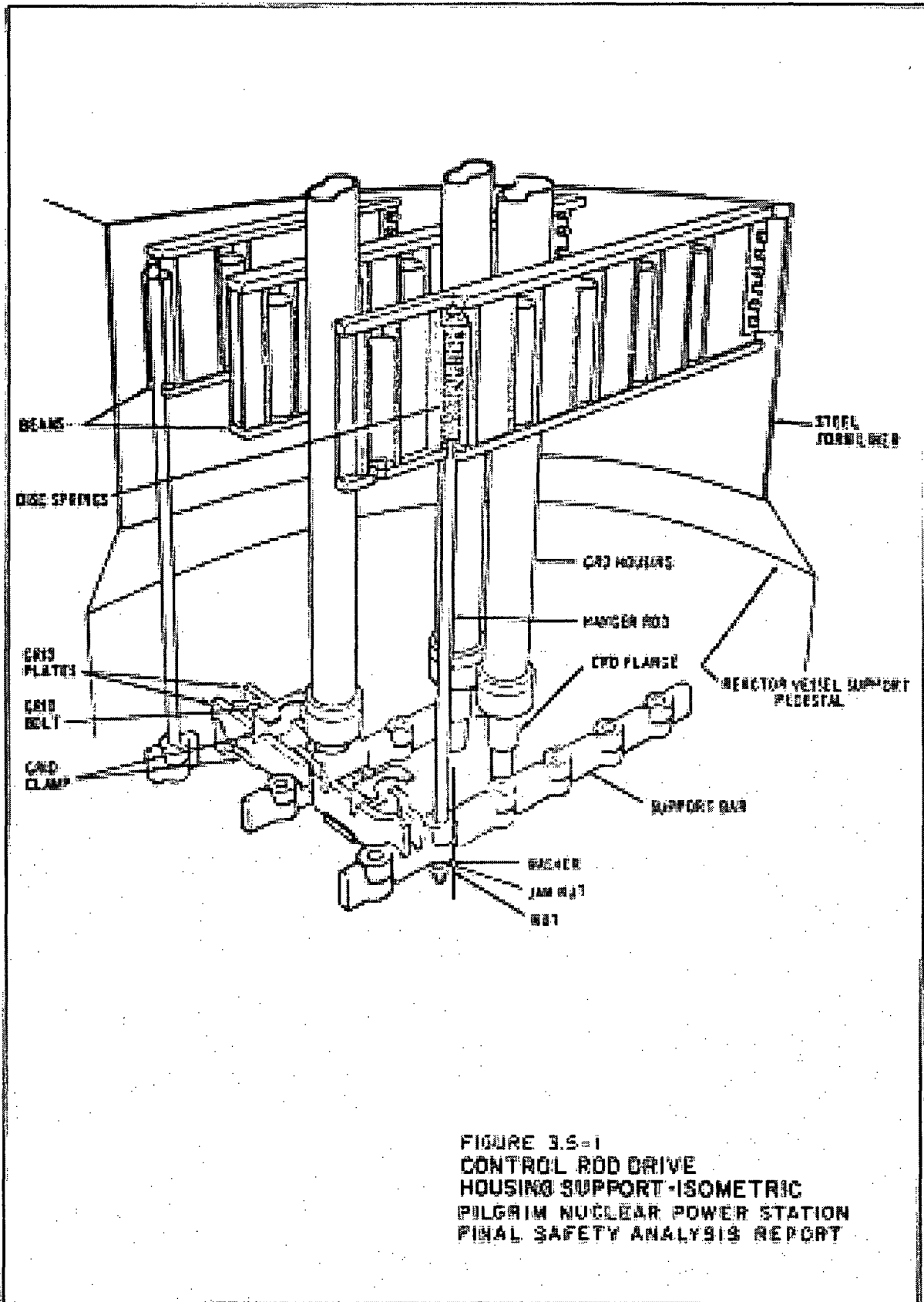

FIGURE 3.5-1
CONTROL ROD DRIVE
HOUSING SUPPORT - ISOMETRIC
PILGRIM NUCLEAR POWER STATION
FINAL SAFETY ANALYSIS REPORT

2.3 LOWER PLENUM ACCESS

The CRD housings, CRD housing caps, and stub tubes shall be inspected by the VT-3 method when accessible. On each of the 145 CRDs there are three welds in this area. CRDH-1 is the CRD cap-to-tube weld, CRDH/ST-1 is the CRD housing-to-stub tube weld, and ST/RPV-1 is the CRD stub tube-to-vessel weld. The housing tubes are 304 stainless steel, the stub tubes are NiCrFe Alloy 600, and the vessel bottom head is low alloy steel. Inspection locations are identified by their CRD location followed by the weld number; e.g., 34-15-CRDH/ST-1.

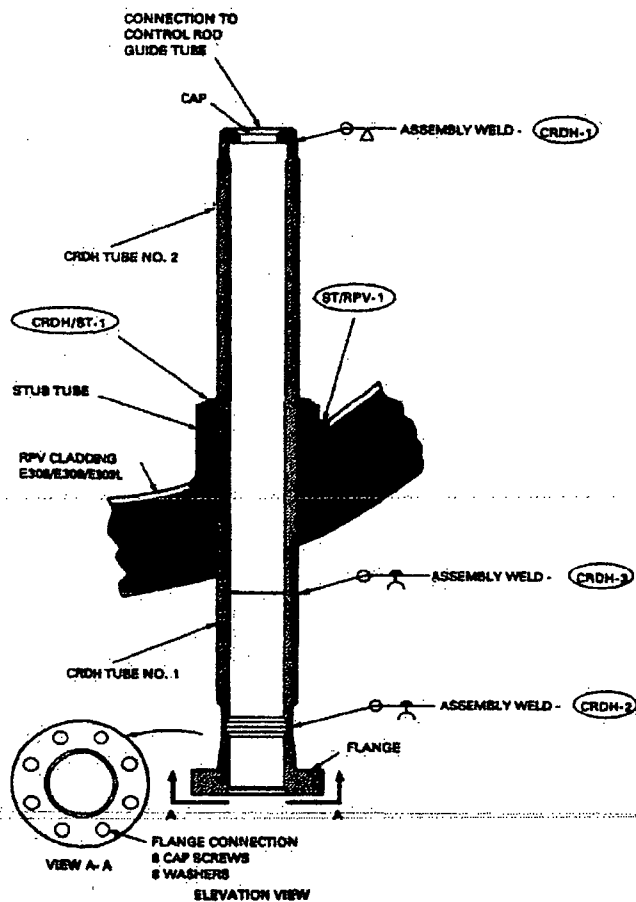

Figure B-2.3 – CRD Stub Tube and Housing

ATTACHMENT 5
 Sheet 9 of 68

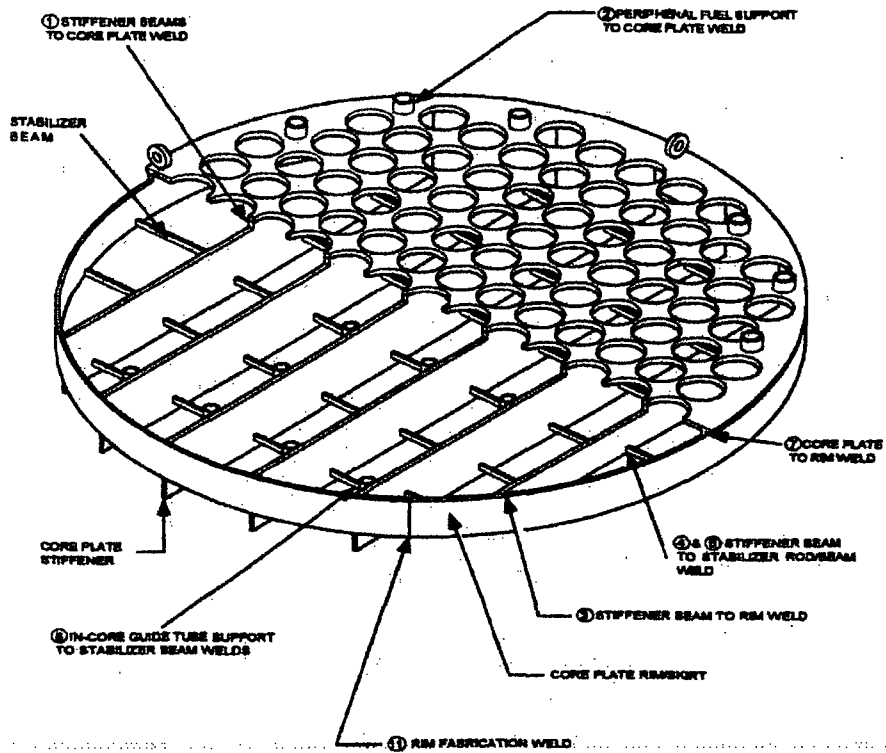

Figure B-3.1 – Core Plate

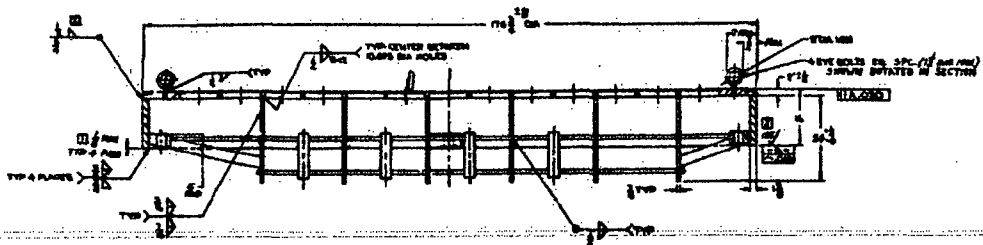

Figure B-3.2 – PNPS Core Plate Section