



**Pacific Gas and  
Electric Company®**

**James R. Becker**  
Vice President  
Diablo Canyon Operations and  
Station Director

Diablo Canyon Power Plant  
P. O. Box 56  
Avila Beach, CA 93424

805.545.3462  
Fax: 805.545.4234

July 26, 2007

PG&E Letter DCL-07-073

U.S. Nuclear Regulatory Commission  
ATTN: Document Control Desk  
Washington, DC 20555-0001

Docket No. 50-275, OL-DPR-80  
DCPP Unit 1

Licensee Event Report 1-2007-002-00

Manual Reactor Trips During Mode 3 Rod Testing Due to Crud Related Rod  
Slippage

Dear Commissioners and Staff:

In accordance with 10CFR50.73(a)(2)(iv)(A), Pacific Gas and Electric Company (PG&E) is submitting the enclosed Licensee Event Report regarding a manual reactor trip of Unit 1 in response to a control rod slipping during testing in Mode 3 (hot standby). The slippage occurred two additional times during mitigation activities. This event was initially reported under Emergency Notification System Event Number 43391 in accordance with 10 CFR 50.72(b)(3)(iv)(A).

This event did not adversely affect the health and safety of the public.

PG&E makes no regulatory commitments (as defined by NEI 99-04) in this letter. The corrective actions described in this letter are not necessary to maintain compliance with regulations. This letter includes no revisions to existing regulatory commitments.

Sincerely,

  
James R. Becker

ssz/2254/A0699025 and A0699045

Enclosures

cc/enc: Terry W. Jackson, NRC Senior Resident Inspector  
Bruce S. Mallett, NRC Region IV  
Alan B. Wang, NRR Project Manager  
cc: Diablo Distribution

A member of the STARS (Strategic Teaming and Resource Sharing) Alliance  
Callaway • Comanche Peak • Diablo Canyon • Palo Verde • South Texas Project • WolfCreek

*JEAD*  
*NRR*

# LICENSEE EVENT REPORT (LER)

(See reverse for required number of digits/characters for each block)

Estimated burden per response to comply with this mandatory collection request: 50 hours. Reported lessons learned are incorporated into the licensing process and fed back to industry. Send comments regarding burden estimate to the Records and FOIA/Privacy Service Branch (T-5 F52), U.S. Nuclear Regulatory Commission, Washington, DC 20555-0001, or by internet e-mail to infocollects@nrc.gov, and to the Desk Officer, Office of Information and Regulatory Affairs, NEOB-10202, (3150-0104), Office of Management and Budget, Washington, DC 20503. If a means used to impose an information collection does not display a currently valid OMB control number, the NRC may not conduct or sponsor, and a person is not required to respond to, the information collection.

<b>1. FACILITY NAME</b> Diablo Canyon Unit 1	<b>2. DOCKET NUMBER</b> <b>05000275</b>	<b>3. PAGE</b> <b>1 OF 10</b>
---	--	----------------------------------

**4. TITLE**  
Manual Reactor Trip In Mode 3 During Control Rod Testing

5. EVENT DATE			6. LER NUMBER			7. REPORT DATE			8. OTHER FACILITIES INVOLVED	
MONTH	DAY	YEAR	YEAR	SEQUENTIAL NUMBER	REV NO.	MONTH	DAY	YEAR	FACILITY NAME	DOCKET NUMBER
05	27	2007	2007	- 002 -	00	07	27	2007	FACILITY NAME	DOCKET NUMBER

<b>9. OPERATING MODE</b>  3	<b>11. THIS REPORT IS SUBMITTED PURSUANT TO THE REQUIREMENTS OF 10 CFR§:</b> <i>(Check all that apply)</i>																																	
<b>10. POWER LEVEL</b>  0	<input type="checkbox"/> 20.2201(b)	<input type="checkbox"/> 20.2203(a)(1)	<input type="checkbox"/> 20.2203(a)(2)(i)	<input type="checkbox"/> 20.2203(a)(2)(ii)	<input type="checkbox"/> 20.2203(a)(2)(iii)	<input type="checkbox"/> 20.2203(a)(2)(iv)	<input type="checkbox"/> 20.2203(a)(2)(v)	<input type="checkbox"/> 20.2203(a)(2)(vi)	<input type="checkbox"/> 20.2203(a)(3)(i)	<input type="checkbox"/> 20.2203(a)(3)(ii)	<input type="checkbox"/> 20.2203(a)(4)	<input type="checkbox"/> 50.36(c)(1)(i)(A)	<input type="checkbox"/> 50.36(c)(1)(ii)(A)	<input type="checkbox"/> 50.36(c)(2)	<input type="checkbox"/> 50.46(a)(3)(ii)	<input type="checkbox"/> 50.73(a)(2)(i)(A)	<input type="checkbox"/> 50.73(a)(2)(i)(B)	<input type="checkbox"/> 50.73(a)(2)(i)(C)	<input type="checkbox"/> 50.73(a)(2)(ii)(A)	<input type="checkbox"/> 50.73(a)(2)(ii)(B)	<input type="checkbox"/> 50.73(a)(2)(iii)	<input checked="" type="checkbox"/> 50.73(a)(2)(iv)(A)	<input type="checkbox"/> 50.73(a)(2)(v)(A)	<input type="checkbox"/> 50.73(a)(2)(v)(B)	<input type="checkbox"/> 50.73(a)(2)(v)(C)	<input type="checkbox"/> 50.73(a)(2)(v)(D)	<input type="checkbox"/> 50.73(a)(2)(vii)	<input type="checkbox"/> 50.73(a)(2)(viii)(A)	<input type="checkbox"/> 50.73(a)(2)(viii)(B)	<input type="checkbox"/> 50.73(a)(2)(ix)(A)	<input type="checkbox"/> 50.73(a)(2)(x)	<input type="checkbox"/> 73.71(a)(4)	<input type="checkbox"/> 73.71(a)(5)	<input type="checkbox"/> OTHER
Specify in Abstract below or in NRC Form 366A																																		

**12. LICENSEE CONTACT FOR THIS LER**

FACILITY NAME Lawrence M. Parker – Senior Regulatory Services Engineer	TELEPHONE NUMBER (Include Area Code) (805) 545-3386
---	--

**13. COMPLETE ONE LINE FOR EACH COMPONENT FAILURE DESCRIBED IN THIS REPORT**

CAUSE	SYSTEM	COMPONENT	MANUFACTURER	REPORTABLE TO EPIX	CAUSE	SYSTEM	COMPONENT	MANUFACTURER	REPORTABLE TO EPIX

<b>14. SUPPLEMENTAL REPORT EXPECTED</b> <input type="checkbox"/> YES (If yes, complete 15. EXPECTED SUBMISSION DATE) <input checked="" type="checkbox"/> NO	<b>15. EXPECTED SUBMISSION DATE</b>	MONTH	DAY	YEAR
--	-------------------------------------	-------	-----	------

**ABSTRACT** (Limit to 1400 spaces, i.e., approximately 15 single-spaced typewritten lines)

At 11:17 PDT, operators manually actuated the reactor protection system causing all rods to fully insert. While operators were performing post outage surveillance testing, Control Bank C was being inserted. At 42 steps withdrawn, Control Rod N-13 indicated a position change to 24 steps withdrawn. In response to this 18-step deviation, and in accordance with the test procedure, operators manually initiated the reactor trip.

The apparent cause of the event was crud accumulation on the drive mechanism for Control Rod N-13.

The slippage occurred two additional times during mitigation activities which were part of troubleshooting and vendor recommendations. Ultimately, operations successfully completed five event free full-length traverse cycles to ensure the drive mechanism was clear of crud.

Corrective actions include implementing the relevant portions of Westinghouse Technical Bulletin TB-06-17 for prevention and mitigation.

# LICENSEE EVENT REPORT (LER) TEXT CONTINUATION

FACILITY NAME (1)	DOCKET NUMBER (2)									LER NUMBER (6)						PAGE (3)			
										YEAR	SEQUENTIAL NUMBER				REVISION NUMBER				
Diablo Canyon Unit 1	0	5	0	0	0	2	7	5	2007	-	0	0	2	-	0	0	2	OF	10

I. Plant Conditions

Diablo Canyon Power Plant (DCPP) Unit 1 was in Mode 3 (hot standby) at normal operating temperature and pressure and performing rod testing following the Unit 1 Fourteenth Refueling Outage (1R14). The rod testing was being performed in accordance with Maintenance Procedure (MP) I-1.6-5, "Rod Control Slave Cyclers Current Order Timing Verification," and MP I-1.6-6, "Rod Control Current Order and Coil Regulation Verification." Surveillance Test Procedure (STP) R-1C, "Digital Rod Position Indicator Functional Test," was also being performed.

II. Description of Problem

A. Background

The primary purpose of the Westinghouse Rod Control System [AA] is to move the control rods [ROD] sequentially in manual or automatic [JD] to startup or shutdown the reactor and maintain reactor coolant temperature [AB]. The safety function is to drop the control rods into the core when required by the Reactor Trip System (RTS) [JC].

With reference to the figure below, the Rod Control System uses a magnetic stepping mechanism that withdraws, holds, or inserts control rod assemblies in fixed increments. The elements of the system include: control room switches and indicators; logic and power cabinets external to containment; and coils, connectors, and stepping mechanisms inside containment. The stepping mechanism or Control Rod Drive Mechanism (CRDM) uses mechanical components including springs and levers that concentrate and react to pulsed electromagnetic fields passed into the Reactor Coolant System (RCS) pressure boundary from exterior coils. If the RTS initiates a reactor trip, electrical power to these coils is interrupted, the magnetic field collapses, springs open the latches, and the rods are allowed to respond to gravity, falling into the core.

# LICENSEE EVENT REPORT (LER) TEXT CONTINUATION

FACILITY NAME (1)	DOCKET NUMBER (2)	LER NUMBER (6)					PAGE (3)		
		YEAR	SEQUENTIAL NUMBER			REVISION NUMBER	3	OF	10
Diablo Canyon Unit 1	05000275	2007	-	0	0	2	-	0	0

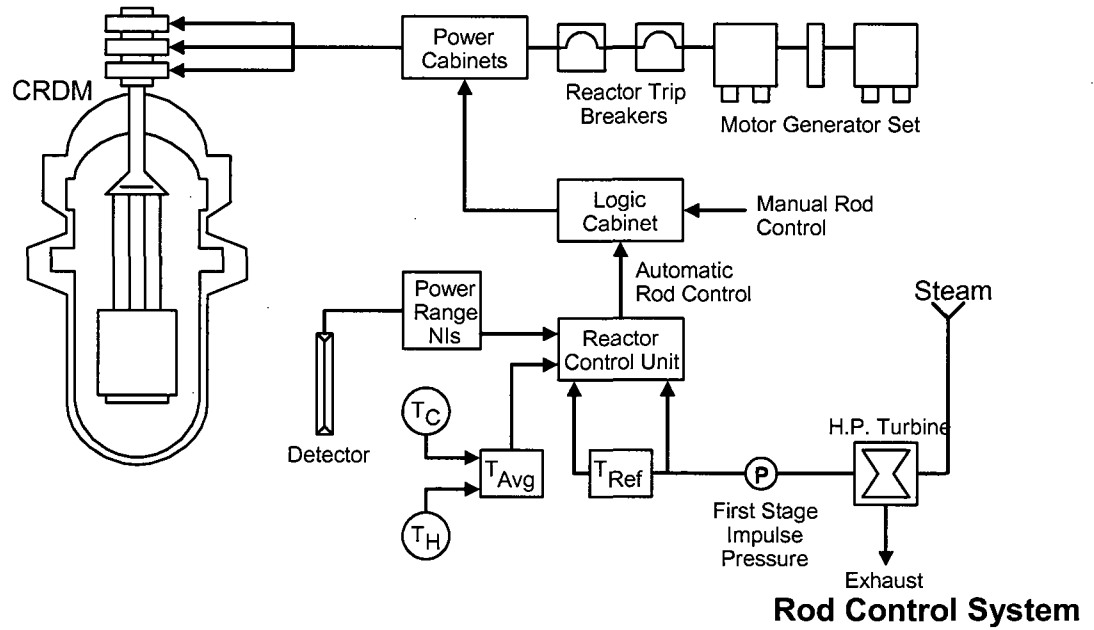

# LICENSEE EVENT REPORT (LER) TEXT CONTINUATION

FACILITY NAME (1)	DOCKET NUMBER (2)							LER NUMBER (6)						PAGE (3)					
								YEAR	SEQUENTIAL NUMBER			REVISION NUMBER							
Diablo Canyon Unit 1	0	5	0	0	0	2	7	5	2007	-	0	0	2	-	0	0	4	OF	10

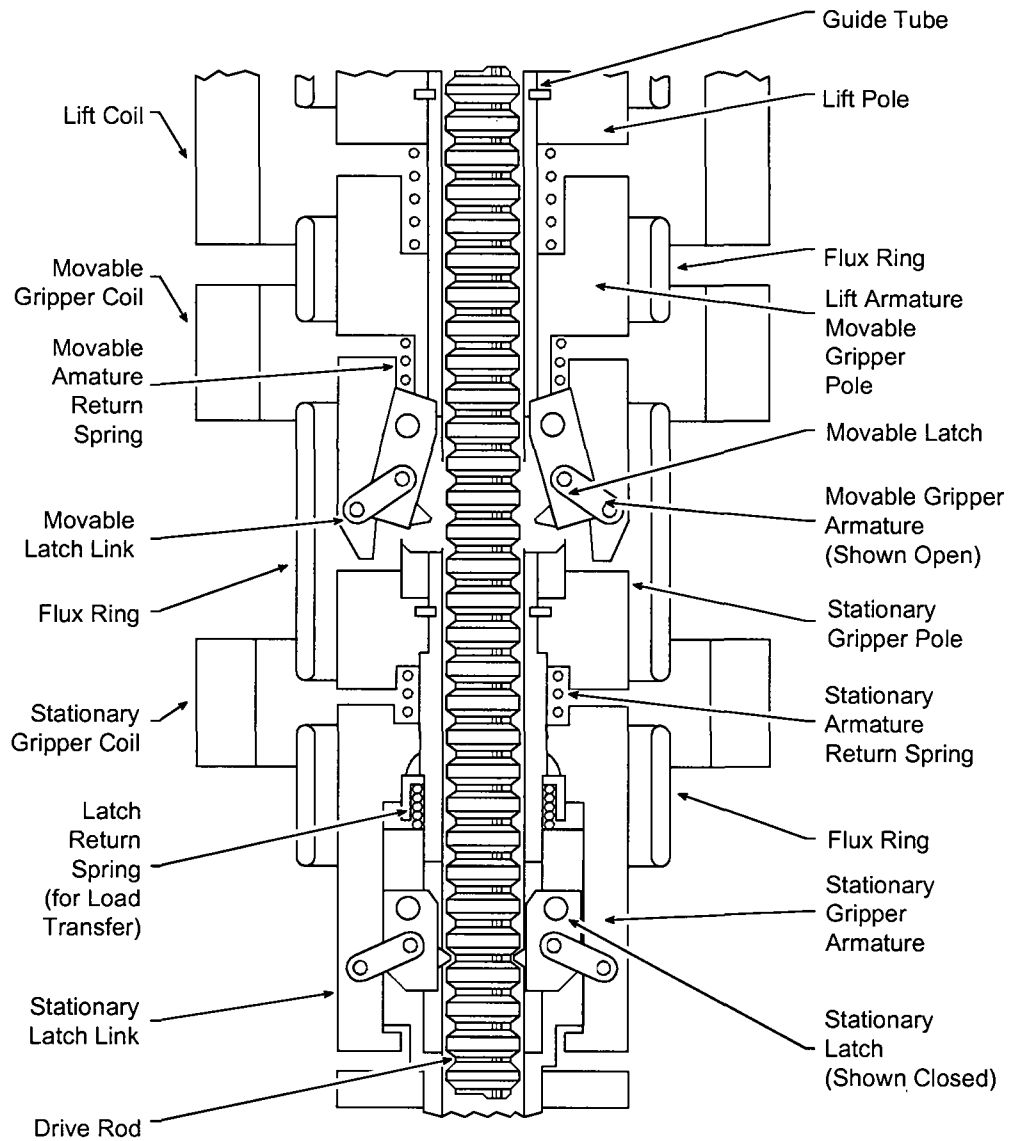

**Rod Stepping Mechanism**

Because the CRDM is inside the RCS pressure boundary in a low flow area above the reactor head, activated corrosion products (crud) can migrate and deposit in this area. Ferromagnetic and, to a lesser degree, paramagnetic materials would also be attracted to the CRDM components due to the strong magnetic fields created by the coils. Industry experience has demonstrated that these factors infrequently occur but can affect CRDM performance.

## LICENSEE EVENT REPORT (LER) TEXT CONTINUATION

FACILITY NAME (1)	DOCKET NUMBER (2)									LER NUMBER (6)						PAGE (3)				
										YEAR	SEQUENTIAL NUMBER				REVISION NUMBER					
Diablo Canyon Unit 1	0 5 0 0 0 2 7 5									2007	-	0	0	2	-	0	0	5	OF	10

During refueling activities, the CRDM is electrically disconnected and then reconnected to support reactor head removal and reassembly. Because the CRDM is contained inside the pressure boundary just above the reactor head, it is not accessible for routine maintenance or inspection.

### B. Event Description

While performing post-1R14 testing prior to startup to verify the electrical and mechanical operation of the Rod Control System, a single rod slipped on three separate occasions. Each event resulted in a procedurally required reactor trip.

On 5/27/07 at 10:45 am PDT, during a procedurally guided rod test, Control Bank C (CBC) was being inserted from the fully withdrawn position (228 steps) to the fully inserted position (0 steps). When the rods reached 42 steps, CBC Control Rod N-13 slipped into the core 18 full steps and stopped at 24 steps.

All rod motion was halted and the reactor trip breakers were opened at 11:17 am PDT as a precaution in accordance with procedural requirements. DCPD Instrument and Control (I&C) Maintenance and Engineering confirmed proper operation of the position indication system and the rod control electronics.

Rod control current order traces were overlaid and compared from Unit 1 Twelfth Refueling Outage (1R12) (no rod events), Unit 1 Thirteenth Refueling Outage (1R13) (one event on the same rod), and 1R14. Current profiles of all the rods in CBC were compared and verified proper operation of all rod control system electronics. Current profiles for Control Rod N-13 one step after and three steps before the event were compared with no abnormality observed in any of the traces.

DCPD I&C Maintenance and Engineering confirmed that there were no abnormalities with the Control Rod N-13 cable electrical connections and its gripper coils. No alarm lights existed in the rod control logic cabinets or power cabinets. The event from 1R13 was reviewed and considered in both cause and corrective action determination.

DCPD Operations, I&C Maintenance, and Engineering evaluated the event, and reviewed data with the rod control/CRDM system original equipment manufacturer (OEM), Westinghouse. This team concluded that the rod control system operated as required, and that the CRDM was not

## LICENSEE EVENT REPORT (LER) TEXT CONTINUATION

FACILITY NAME (1)	DOCKET NUMBER (2)									LER NUMBER (6)						PAGE (3)			
										YEAR	SEQUENTIAL NUMBER				REVISION NUMBER				
Diablo Canyon Unit 1	0	5	0	0	0	2	7	5	2007	-	0	0	2	-	0	0	6	OF	10

fully capturing the rod. Westinghouse and industry experience show that this is consistent with a buildup of crud on the rod and/or gripper.

Rod misalignment or misstepping events have been occurring in the industry sporadically since 1975. Westinghouse Technical Bulletins NSD-TB-77-8 (6/77), NSD-TB-77-14 (10/77), InfoGram IG-05-4 (issued 2005), and TB-06-17 (12/06) all address these events. All of the Westinghouse documents recommend exercising of the misstepped rods following an event. The most conservative recommendation is to operate the misstepped CRDM for five full-length rod excursions to condition the CRDM latching assembly. The intent of this action is to remove any potential crud build-up. Taking these actions, with no further events, would support the conclusion that crud build-up was the cause and was subsequently removed by the exercising.

The actions taken in 1R13 were based on and consistent with the 1977 Westinghouse Technical Bulletins. The subsequent Westinghouse Technical Bulletin, TB-06-17, issued in 2006, provided specific recommendations for dealing with misstepped rods that did not exist in the earlier bulletin. DCPD is implementing corrective actions consistent with OEM recommendations and those provided in TB-06-17.

**C. Status of Inoperable Structures, Systems, or Components that Contributed to the Event**

Exercising of Control Rod N-13 was performed until five consecutive full-length excursions were completed with no misstepping.

**D. Other Systems or Secondary Functions Affected**

None.

**E. Method of Discovery**

The Digital Rod Position Indication (DRPI) system correctly tracked and indicated all rod motion, including the rod slips.

**F. Operator Actions**

In response to each slip event on Control Rod N-13, and as required by plant procedures in place during this testing, control room personnel initiated a reactor trip.

## LICENSEE EVENT REPORT (LER) TEXT CONTINUATION

FACILITY NAME (1)	DOCKET NUMBER (2)									LER NUMBER (6)						PAGE (3)				
										YEAR	SEQUENTIAL NUMBER				REVISION NUMBER					
Diablo Canyon Unit 1	0 5 0 0 0 2 7 5									2007	-	0	0	2	-	0	0	7	OF	10

G. Safety System Responses

All safety systems responded as required. All rods fully inserted.

III. Cause of the Problem

A. Immediate Cause

The immediate evaluation of the event, based on instrumentation response, indicated a misstep of Control Rod N-13.

B. Apparent Root Cause

Based on the sequence of events and evaluation discussed above, the malfunction of Control Rod N-13 was caused by misstepping due to the build-up of crud on the control rod or in the mechanism. This was supported by the following observations:

- The DRPI system was verified to be performing as required, in accordance with applicable maintenance and surveillance test procedures.
- The rod control system was verified to be performing as required, in accordance with applicable maintenance procedures.
- Westinghouse analysis of the first event and relevant data supplied by Pacific Gas and Electric Company concluded that the event was characteristic of misstepping due to the presence of crud.
- Subsequent troubleshooting, and the resulting rod operation during exercising, supported the Westinghouse experience regarding misstepping events, consistent with the Technical Bulletin and the cause and corrective actions.

C. Contributory Cause

As noted in Technical Bulletin TB-06-17, precursors to these events could be either electrical (typically bad electrical contacts in connectors) or mechanical (crud).

The following are details of tests performed to identify precursors. Plant maintenance procedures MP I-1.6-2, "Rod Control CRDM Coil Resistance Checks," I-1.6-5, "Rod Control Slave Cyclor Current Order Timing Verification," and I-1.6-6, "Rod Control Current Order and Coil Regulation Verification," are designed to verify the functionality of the rod control



## LICENSEE EVENT REPORT (LER) TEXT CONTINUATION

FACILITY NAME (1)	DOCKET NUMBER (2)									LER NUMBER (6)						PAGE (3)			
										YEAR	SEQUENTIAL NUMBER			REVISION NUMBER					
Diablo Canyon Unit 1	0	5	0	0	0	2	7	5	2007	-	0	0	2	-	0	0	8	OF	10

system and performance of these procedures would identify precursors that can cause control rod misstepping.

Since the grippers are not accessible for visual inspection, performance of MP I-1.6-6 is limited to verification of the performance parameters of control rod assemblies. Given this, a thorough comparative study of performance parameter averages against Control Rod N-13 individual data was performed for all 8 control rods in CBC for 1R12, 1R13, and 1R14. This review included:

- Drop times
- Gripper and lift coil resistances
- Gripper and lift coil inductances
- Gripper and lift coil insulation resistances
- Gripper and lift coil full current and reduced current amplitudes
- CRDM operating coil current profiles

The results of the study concluded that all data for Control Rod N-13 were consistent with the other control rods, with no adverse trends and, therefore, operating as required. This study would have identified any abnormalities with CRDM function that would be consistent with the potential precursors for misstepping.

In response to industry crud issues, and to study water chemistry management practices, DCPD performed a video inspection of control rod drive shafts during Unit 2 Thirteenth Refueling Outage. Unit 2 has not had any occurrences of misstepping. This review did not identify any signs of crud formation and showed clean rod drive shafts.

Based on this, the inaccessibility of the CRDM, and Westinghouse determining that crud build-up is localized, it was concluded that there will be little value in performing future inspections of the CRDM or rod drive shaft equipment. This is also supported by the 1977 Technical Bulletin findings.

#### IV. Assessment of Safety Consequences

The safety related function of the Rod Control System to release the control rods in response to a reactor trip signal was never compromised. The Solid State Protection System functioned as designed upon receipt of the manual reactor trip signals. The reactor trip breakers opened and all control rods and shutdown rods inserted as designed. These events were within the bounds of the Updated Final Safety Analysis Report, and the post trip transient response was as expected.

## LICENSEE EVENT REPORT (LER) TEXT CONTINUATION

FACILITY NAME (1)	DOCKET NUMBER (2)									LER NUMBER (6)						PAGE (3)			
										YEAR	SEQUENTIAL NUMBER			REVISION NUMBER					
Diablo Canyon Unit 1	0	5	0	0	0	2	7	5	2007	-	0	0	2	-	0	0	9	OF	10

Therefore, the event is not considered risk significant, and it did not adversely affect the health and safety of the public.

### V. Corrective Actions

#### A. Immediate Corrective Actions

Exercising of Control Rod N-13 was performed until five consecutive full-length excursions were completed with no misstepping.

#### B. Corrective Actions to Prevent Recurrence

Perform exercising of control rods, as recommended in Westinghouse TB-06-17, as follows:

- Refueling outages: Modify plant procedures to allow five full-length rod excursions, both hot and cold prior to restart.
- During routine surveillance testing: Modify plant procedures such that an up one step, down one step type of repetitive sequence of the rod group can be utilized for a few cycles to displace any loose crud prior to any larger rod movement.
- Following a misstep event: Modify plant procedures such that the response to a misstep event is preferably a full-length rod drop, but has a minimum of five successful full-length rod excursions.

### VI. Additional Information

#### A. Failed Components

None.

#### B. Previous Similar Events

Industry-wide, Westinghouse research indicates that from 1990 to 2006 the incidence of crud related CRDM misstepping is less than one per year for all Westinghouse and Combustion Engineering reactors in the United States.

At DCCP, there was one previous event during testing following the 1R13 refueling outage involving the same (N-13) control rod. The slip did not require a reactor trip or reporting. The rod was restored and testing continued without incident. At the time, Westinghouse felt that no

## LICENSEE EVENT REPORT (LER) TEXT CONTINUATION

FACILITY NAME (1)	DOCKET NUMBER (2)								LER NUMBER (6)						PAGE (3)				
									YEAR	SEQUENTIAL NUMBER			REVISION NUMBER						
Diablo Canyon Unit 1	0	5	0	0	0	2	7	5	2007	-	0	0	2	-	0	0	10	OF	10

additional exercising of the rod was necessary since performance had been restored, and exercising performed as part of the normal restart and restoration activities would be adequate.