

BSEP 07-0067
Enclosure 9

AREVA Report ANP-2624(NP), Revision 0,
Brunswick Units 1 and 2 LOCA-ECCS Analysis
MAPLHGR Limit for ATRIUM™-10 Fuel,
dated June 2007

ANP-2624(NP)
Revision 0

**Brunswick Units 1 and 2
LOCA-ECCS Analysis MAPLHGR Limit
for ATRIUM™-10 Fuel**

June 2007

AREVA NP Inc.

ANP-2624(NP)
Revision 0

**Brunswick Units 1 and 2
LOCA-ECCS Analysis MAPLHGR Limit
for ATRIUM™-10 Fuel**

Copyright © 2007

AREVA NP Inc.
All Rights Reserved

Nature of Changes

Item	Page	Description and Justification
1.	All	This is the initial issue.

Contents

1.0	Introduction	1-1
2.0	Summary	2-1
3.0	LOCA Description	3-1
3.1	Accident Description	3-1
3.2	Acceptance Criteria	3-2
4.0	LOCA Analysis Description	4-1
4.1	Blowdown Analysis	4-1
4.2	Refill/Reflood Analysis	4-2
4.3	Heatup Analysis	4-2
4.4	Plant Parameters	4-3
4.5	ECCS Parameters	4-3
5.0	MAPLHGR Analysis Description and Results	5-1
6.0	Conclusions	6-1
7.0	References	7-1

Tables

2.1	LOCA Results for Limiting Conditions	2-2
4.1	Initial Conditions	4-5
4.2	Reactor System Parameters	4-6
4.3	ATRIUM-10 Fuel Assembly Parameters	4-7
4.4	High-Pressure Coolant Injection Parameters	4-8
4.5	Low-Pressure Coolant Injection Parameters	4-9
4.6	Low-Pressure Core Spray Parameters	4-10
4.7	Automatic Depressurization System Parameters	4-11
4.8	Available ECCS for Recirculation Line Break LOCAs	4-12
5.1	Event Times for Limiting Break 0.8 DEG Pump Discharge SF-LPCI Top-Peaked Axial	5-2
5.2	ATRIUM-10 MAPLHGR Analysis Results	5-3

Figures

2.1	MAPLHGR Limit for ATRIUM-10 Fuel.....	2-3
4.1	Flow Diagram for EXEM BWR-2000 ECCS Evaluation Model.....	4-13
4.2	RELAX System Model.....	4-14
4.3	RELAX Hot Channel Model Top-Peaked Axial	4-15
4.4	ECCS Schematic	4-16
4.5	Axial Power Distribution in RELAX Calculation	4-17
5.1	Limiting Break Upper Plenum Pressure	5-4
5.2	Limiting Break Total Break Flow Rate	5-4
5.3	Limiting Break Core Inlet Flow Rate.....	5-5
5.4	Limiting Break Core Outlet Flow Rate.....	5-5
5.5	Limiting Break Intact Loop Jet Pump Drive Flow Rate.....	5-6
5.6	Limiting Break Intact Loop Jet Pump Suction Flow Rate	5-6
5.7	Limiting Break Intact Loop Jet Pump Exit Flow Rate	5-7
5.8	Limiting Break Broken Loop Jet Pump Drive Flow Rate	5-7
5.9	Limiting Break Broken Loop Jet Pump Suction Flow Rate.....	5-8
5.10	Limiting Break Broken Loop Jet Pump Exit Flow Rate.....	5-8
5.11	Limiting Break ADS Flow Rate.....	5-9
5.12	Limiting Break LPCS Flow Rate.....	5-9
5.13	Limiting Break Intact Loop LPCI Flow Rate	5-10
5.14	Limiting Break Broken Loop LPCI Flow Rate.....	5-10
5.15	Limiting Break Upper Downcomer Mixture Level	5-11
5.16	Limiting Break Lower Downcomer Mixture Level	5-11
5.17	Limiting Break Intact Loop Discharge Line Liquid Mass	5-12
5.18	Limiting Break Upper Plenum Liquid Mass	5-12
5.19	Limiting Break Lower Plenum Liquid Mass	5-13
5.20	Limiting Break Hot Channel Inlet Flow Rate	5-13
5.21	Limiting Break Hot Channel Outlet Flow Rate.....	5-14
5.22	Limiting Break Hot Channel Coolant Temperature at the Hot Node at EOB.....	5-14
5.23	Limiting Break Hot Channel Quality at the Hot Node at EOB.....	5-15
5.24	Limiting Break Hot Channel Heat Transfer Coeff. at the Hot Node at EOB	5-15
5.25	Limiting Break Hot Channel Reflood Junction Liquid Mass Flow Rate	5-16
5.26	Limiting Break Cladding Temperatures	5-16

Nomenclature

ADS	automatic depressurization system
ADSVOOS	ADS valve out of service
ANS	American Nuclear Society
BWR	boiling-water reactor
CFR	Code of Federal Regulations
CMWR	core average metal-water reaction
DEG	double-ended guillotine
DG	diesel generator
ECCS	emergency core cooling system
EOB	end of blowdown
HPCI	high-pressure coolant injection
LHGR	linear heat generation rate
LOCA	loss-of-coolant accident
LPCI	low-pressure coolant injection
LPCS	low-pressure core spray
MAPLHGR	maximum average planar linear heat generation rate
MCPR	minimum critical power ratio
MWR	metal-water reaction
NRC	Nuclear Regulatory Commission, U.S.
PCT	peak cladding temperature
RDIV	recirculation discharge valve
SF-BATT	single failure of battery (DC) power
SF-HPCI	single failure of the HPCI system
SF-LPCI	single failure of an LPCI valve
SLO	single-loop operation

1.0 Introduction

The results of loss-of-coolant accident emergency core cooling system (LOCA-ECCS) analyses for Brunswick Units 1 and 2 are documented in this report. The results provide the maximum average planar linear heat generation rate (MAPLHGR) limit for ATRIUM™-10* fuel as a function of exposure for normal (two-loop) operation. As shown in Reference 1, the MAPLHGR limit for single-loop operation (SLO) is equal to 0.85 times the two-loop limit.

The analyses documented in this report were performed with LOCA Evaluation Models developed by AREVA NP† and approved for reactor licensing analyses by the U.S. Nuclear Regulatory Commission (NRC). The models and computer codes used by AREVA for LOCA analyses are collectively referred to as the EXEM BWR-2000 Evaluation Model. The EXEM BWR-2000 Evaluation Model and NRC approval are documented in Reference 2. A summary description of the LOCA analysis methodology is provided in Section 4.0.

The application of the EXEM BWR-2000 Evaluation Model for the Brunswick Units 1 and 2 LOCA break spectrum analysis is documented in Reference 1. The LOCA conditions evaluated in Reference 1 include break size, type, location, axial power shape, and ECCS single failure. The limiting LOCA break characteristics identified in Reference 1 are presented below.

Limiting LOCA Break Characteristics	
Location	Recirculation discharge pipe
Type / size	Double-ended guillotine / 0.8 discharge coefficient
Single failure	Low-pressure coolant injection valve
Axial power shape	Top-peaked

* ATRIUM is a trademark of AREVA NP.

† AREVA NP Inc. is an AREVA and Siemens company

2.0 Summary

The MAPLHGR limit was determined by applying the EXEM BWR-2000 Evaluation Model for the analysis of the limiting LOCA event. The exposure-dependent MAPLHGR limit for ATRIUM-10 fuel is shown in Figure 2.1. The results of these calculations confirm that the LOCA acceptance criteria in the Code of Federal Regulations (10 CFR 50.46) are met for operation at or below these limits.

Local power distributions for the Cycle 17 neutronic designs as well as applicable equilibrium cycle designs were used in the heatup analyses performed for this report. Results for the limiting neutronic design are presented in Section 5.0. The peak cladding temperature (PCT) and metal-water reaction (MWR) results for the ATRIUM-10 fuel are presented in Table 2.1.

The SLO analyses (Reference 1) support operation with an ATRIUM-10 MAPLHGR multiplier of 0.85 applied to the normal two-loop operation MAPLHGR limit.

[

]

**Table 2.1 LOCA Results for
Limiting Conditions**

Parameter	ATRIUM-10
Exposure (GWd/MTU)	0.0
Peak cladding temperature (°F)	1900
Local cladding oxidation (max %)	1.16
Total hydrogen generated (% of total hydrogen possible)	< 0.50

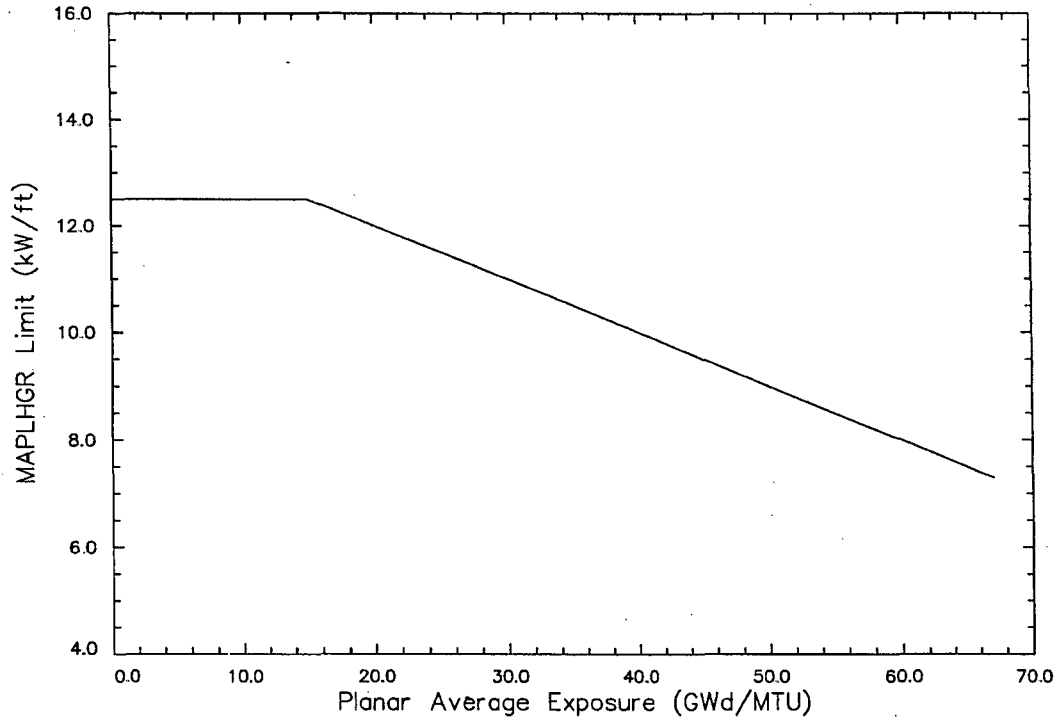

Average Planar Exposure (GWd/MTU)	ATRIUM-10 MAPLHGR (kW/ft)
0	12.5
15	12.5
67	7.3

Figure 2.1 MAPLHGR Limit for ATRIUM-10 Fuel

3.0 LOCA Description

3.1 *Accident Description*

The LOCA is described in the Code of Federal Regulations 10 CFR 50.46 as a hypothetical accident that results in a loss of reactor coolant from breaks in reactor coolant pressure boundary piping up to and including a break equivalent in size to a double-ended rupture of the largest pipe in the reactor coolant system. There is not a specifically identified cause that results in the pipe break. However, for the purpose of identifying a design basis accident, the pipe break is postulated to occur inside the primary containment before the first isolation valve.

For a boiling water reactor (BWR), a LOCA may occur over a wide spectrum of break locations and sizes. Responses to the break vary significantly over the break spectrum. The largest possible break is a double-ended rupture of a recirculation pipe; however, this is not necessarily the most severe challenge to the emergency core cooling system (ECCS). A double-ended rupture of a main steam line causes the most rapid primary system depressurization, but because of other phenomena, steam line breaks are seldom limiting with respect to the event acceptance criteria (10 CFR 50.46). Because of these complexities, an analysis covering the full range of break sizes and locations is required. The results of the Brunswick Units 1 and 2 ATRIUM-10 break spectrum calculations using EXEM BWR-2000 LOCA methodology are summarized in Reference 1.

Regardless of the initiating break characteristics, the event response is conveniently separated into three phases: the blowdown phase, the refill phase, and the reflood phase. The relative duration of each phase is strongly dependent upon the break size and location. The last two phases are often combined and will be discussed together in this report.

During the blowdown phase of a LOCA, there is a net loss of coolant inventory, an increase in fuel cladding temperature due to core flow degradation, and for the larger breaks, the core becomes fully or partially uncovered. There is a rapid decrease in pressure during the blowdown phase. During the early phase of the depressurization, the exiting coolant provides core cooling. Low-pressure core spray (LPCS) also provides some heat removal. The end of the blowdown (EOB) phase is defined to occur when the system reaches the pressure corresponding to rated LPCS flow.

In the refill phase of a LOCA, the ECCS is functioning and there is a net increase of coolant inventory. During this phase the core sprays provide core cooling and, along with low-pressure and high-pressure coolant injection (LPCI and HPCI), supply liquid to refill the lower portion of the reactor vessel. In general, the core heat transfer to the coolant is less than the fuel decay heat rate and the fuel cladding temperature continues to increase during the refill phase.

In the reflood phase, the coolant inventory has increased to the point where the mixture level reenters the core region. During the core reflood phase, cooling is provided above the mixture level by entrained reflood liquid and below the mixture level by pool boiling. Sufficient coolant eventually reaches the core hot node and the fuel cladding temperature decreases.

3.2 *Acceptance Criteria*

A LOCA is a potentially limiting event that may place constraints on fuel design, local power peaking, and in some cases, acceptable core power level. During a LOCA, the normal transfer of heat from the fuel to the coolant is disrupted. As the liquid inventory in the reactor decreases, the decay heat and stored energy of the fuel cause a heatup of the undercooled fuel assembly. In order to limit the amount of heat that can contribute to the heatup of the fuel assembly during a LOCA, an operating limit on the MAPLHGR is applied to each fuel assembly in the core.

The Code of Federal Regulations prescribes specific acceptance criteria (10 CFR 50.46) for a LOCA event as well as specific requirements and acceptable features for Evaluation Models (10 CFR 50 Appendix K). The conformance of the EXEM BWR-2000 LOCA Evaluation Models to Appendix K is described in Reference 2. The ECCS must be designed such that the plant response to a LOCA meets the following acceptance criteria specified in 10 CFR 50.46:

- The calculated maximum fuel element cladding temperature shall not exceed 2200°F.
- The calculated local oxidation of the cladding shall nowhere exceed 0.17 times the local cladding thickness.
- The calculated total amount of hydrogen generated from the chemical reaction of the cladding with water or steam shall not exceed 0.01 times the hypothetical amount that would be generated if all of the metal in the cladding cylinders surrounding the fuel, except the cladding surrounding the plenum volume, were to react.
- Calculated changes in core geometry shall be such that the core remains amenable to cooling.

- After any calculated successful initial operation of the ECCS, the calculated core temperature shall be maintained at an acceptably low value and decay heat shall be removed for the extended period of time required by the long-lived radioactivity remaining in the core.

These criteria are commonly referred to as the peak cladding temperature (PCT) criterion, the local oxidation criterion, the hydrogen generation criterion, the coolable geometry criterion, and the long-term cooling criterion. A MAPLHGR limit is established for each fuel type to ensure that these criteria are met.

LOCA analysis results demonstrating that the PCT, local oxidation, and hydrogen generation criteria are met are provided in Section 5.0. Compliance with these three criteria ensures that a coolable geometry is maintained. Compliance with the long-term coolability criterion is discussed in Reference 1.

4.0 LOCA Analysis Description

The Evaluation Model used for the break spectrum analysis is the EXEM BWR-2000 LOCA analysis methodology described in Reference 2. The EXEM BWR-2000 methodology employs three major computer codes to evaluate the system and fuel response during all phases of a LOCA. These are the RELAX, HUXY, and RODEX2 computer codes. RELAX is used to calculate the system and hot channel response during the blowdown, refill, and reflood phases of the LOCA. The HUXY code is used to perform heatup calculations for the entire LOCA, and calculates the PCT and local clad oxidation at the axial plane of interest. RODEX2 is used to determine fuel parameters (such as stored energy) for input to the other LOCA codes. The code interfaces for the LOCA methodology are illustrated in Figure 4.1.

A complete analysis for a given break size starts with the specification of fuel parameters using RODEX2 (Reference 3). RODEX2 is used to determine the initial stored energy for both the blowdown analysis (RELAX hot channel) and the heatup analysis (HUXY). This is accomplished by ensuring that the initial stored energy in RELAX and HUXY is the same or higher than that calculated by RODEX2 for the power, exposure, and fuel design being considered.

4.1 *Blowdown Analysis*

The RELAX code (Reference 2) is used to calculate the system thermal-hydraulic response during the blowdown phase of the LOCA. For the system blowdown analysis, the core is represented by an average core channel. The reactor core is modeled with heat generation rates determined from reactor kinetics equations with reactivity feedback and decay heat as required by Appendix K of 10 CFR 50. The reactor vessel nodalization for the system analysis is shown in Figure 4.2. This nodalization is consistent with that used in the topical report submitted to the NRC (Reference 2).

The RELAX blowdown analysis is performed from the time of the break initiation through the end of blowdown (EOB). The system blowdown calculation provides the upper and lower plenum transient boundary conditions for the hot channel analysis.

Following the system blowdown calculation, another RELAX analysis is performed to analyze the maximum power assembly (hot channel) of the core. The RELAX hot channel blowdown calculation determines the hot channel fuel, cladding, and coolant temperatures during the

blowdown phase of the LOCA. The RELAX hot channel nodalization is shown in Figure 4.3 for a top-peaked power shape. The hot channel blowdown analysis is performed using the system blowdown results to supply the core power and the system boundary conditions at the core inlet and exit. The initial average fuel rod temperature at the limiting plane of the hot channel is conservative relative to the average fuel rod temperature calculated by RODEX2 for operation of the ATRIUM-10 assembly at the MAPLHGR limit. The heat transfer coefficient and fluid condition results from the RELAX hot channel calculation are used as input to the HUXY heatup analysis.

4.2 **Refill/Reflood Analysis**

The RELAX code is also used to compute the system and hot channel hydraulic response during the refill/reflood phase of the LOCA. The RELAX system and RELAX hot channel analyses continue beyond the end of blowdown to analyze system and hot channel responses during the refill and reflood phases. The refill phase is the period when the lower plenum is filling due to ECCS injection. The reflood phase is the period when some portions of the core and hot assembly are being cooled with ECCS water entering from the lower plenum. The purpose of the RELAX calculations beyond blowdown is to determine the time when the liquid flow via upward entrainment from the bottom of the core becomes high enough at the hot node in the hot assembly to end the temperature increase of the fuel rod cladding. This event time is called the time of hot node reflood. [

]

The RELAX calculations provide HUXY with the time of hot node reflood and the time when the liquid has risen in the bypass to the height of the axial plane of interest (time of bypass reflood).

4.3 **Heatup Analysis**

The HUXY code (Reference 4) is used to perform heatup calculations for the entire LOCA transient and provides PCT and local clad oxidation at the axial plane of interest. The heat generated by metal-water reaction (MWR) is included in the HUXY analysis. HUXY is used to calculate the thermal response of each fuel rod in one axial plane of the hot channel assembly. These calculations consider thermal-mechanical interactions within the fuel rod. The clad swelling and rupture models from NUREG-0630 have been incorporated into HUXY

(Reference 5). The HUXY code complies with the 10 CFR 50 Appendix K criteria for LOCA Evaluation Models.

HUXY uses the EOB time and the times of core bypass reflood and core reflood at the axial plane of interest from the RELAX analysis. [

] Throughout the calculations, decay power is determined based on the ANS 1971 decay heat curve plus 20% as described in Reference 2. [

] are used in the HUXY analysis. The principal results of a HUXY heatup analysis are the PCT and the percent local oxidation of the fuel cladding, often called the %MWR. The core average metal-water reaction (CMWR) criterion of less than 1.0% can often be satisfied by demonstrating that the maximum planar MWR calculated by HUXY is less than 1.0%.

4.4 *Plant Parameters*

The LOCA break spectrum analysis is performed using plant parameters provided by the utility. Table 4.1 provides a summary of reactor initial conditions used in the break spectrum analysis. Table 4.2 lists selected reactor system parameters.

The break spectrum analysis is performed for a full core of ATRIUM-10 fuel. Some of the key fuel parameters used in the break spectrum analysis are summarized in Table 4.3. A top-peaked axial power shape, shown in Figure 4.5, was identified as the most conservative power shape for the limiting break (Reference 1).

4.5 *ECCS Parameters*

The ECCS configuration is shown in Figure 4.4. Table 4.4 – Table 4.7 provide the important ECCS characteristics assumed in the analysis. The ECCS is modeled as fill junctions connected to the appropriate reactor locations: LPCS injects into the upper plenum, HPCI injects into the upper downcomer and LPCI injects into the recirculation lines. Although HPCI is expected to be available, no analysis mitigation credit is assumed for the HPCI system in any of the analyses discussed in this report.

The flow through each ECCS valve is determined based on system pressure and valve position. Flow versus pressure for a fully open valve is obtained by linearly interpolating the pump capacity data provided in Table 4.4 – Table 4.6. No credit for ECCS flow is assumed until the ECCS injection valves are fully open. Also, no credit for ECCS flow is assumed until ECCS pumps reach rated speed.

The automatic depressurization (ADS) valves are modeled as a junction connecting the reactor steam line to the suppression pool. The flow through the ADS valves is calculated based on pressure and valve flow characteristics. The valve flow characteristics are determined such that the calculated flow is equal to the rated capacity at the reference pressure shown in Table 4.7. Only five ADS valves are assumed operable in the analyses to support operation with one ADSVOOS and the potential single failure of one ADS valve during the LOCA.

In the AREVA LOCA analysis model, ECCS initiation is assumed to occur when the water level drops to the applicable level setpoint. No credit is assumed for the start of LPCS or LPCI due to high drywell pressure. [

]

The potentially limiting single failures of the ECCS are provided in Section 5.0 of Reference 1. Table 4.8 shows these failures and gives the ECCS systems that are available for each assumed failure.

Table 4.1 Initial Conditions

Parameter	Value
Reactor power (% of rated)	102
[]
Reactor power (MWt)	2981.5
[]
[]
Steam flow rate (Mlb/hr)	13.1
Steam dome pressure (psia)	1048.8
Core inlet enthalpy (Btu/lb)	527.7
ATRIUM-10 hot assembly MAPLHGR (kW/ft)	12.5
[]
Axial power shape	Figure 4.5

* [

]

**Table 4.2 Reactor System
Parameters**

Parameter	Value
Vessel ID (in)	220.5
Number of fuel assemblies	560
Recirculation suction pipe area (ft ²)	3.67
1.0 DEG suction break area (ft ²)	7.33
Recirculation discharge pipe area (ft ²)	3.67
1.0 DEG discharge break area (ft ²)	7.33

**Table 4.3 ATRIUM-10 Fuel Assembly
 Parameters**

Parameter	Value
Fuel rod array	10x10
Number of fuel rods per assembly	83 (full-length rods) 8 (part-length rods)
Non-fuel rod type	Water channel replaces 9 fuel rods
Fuel rod OD (in)	0.3957
Active fuel length (in) (including blankets)	149.45 (full-length rods) 90.0 (part-length rods)
Water channel outside width (in)	1.378
Fuel channel thickness (in)	0.075 (minimum wall) 0.100 (corner)
Fuel channel internal width (in)	5.278

Table 4.4 High-Pressure Coolant Injection Parameters

Parameter	Value
Coolant temperature (maximum) (°F)	140
Initiating Signals and Setpoints	
Water level (in)*	459
High drywell pressure (psig)	Not used
Time Delays	
Time for HPCI pump to reach rated speed and injection valve wide open (sec)	60
Delivered Coolant Flow Rate Versus Pressure	
Vessel to Torus ΔP (psid)	Flow Rate (gpm)
0	0
150	3825
1164	3825

* Relative to vessel zero.

Table 4.5 Low-Pressure Coolant Injection Parameters

Parameter	Value	
Reactor pressure permissive for opening valves - analytical (psia)	410	
Coolant temperature (maximum) (°F)	160	
Initiating Signals and Setpoints		
Water level (in)*	358	
High drywell pressure (psig)	Not used	
Time Delays		
Time for LPCI pumps to reach rated speed (maximum) (sec)	31.8	
LPCI injection valve stroke time (sec)	37.5	
Delivered Coolant Flow Rate Versus Pressure		
Vessel to Torus ΔP (psid)	Flow rate for 1 pump injecting into 1 recirculation loop (gpm)	Flow rate for 2 pumps injecting into 1 recirculation loop (gpm)
0	8690	14,420
20	7000	12,000
202	0	0

* Relative to vessel zero.

Table 4.6 Low-Pressure Core Spray Parameters

Parameter	Value
Reactor pressure permissive for opening valves - analytical (psia)	410
Coolant temperature (maximum) (°F)	160
Initiating Signals and Setpoints	
Water level (in)*	358
High drywell pressure (psig)	Not used
Time Delays	
Time for LPCS pumps to reach rated speed (maximum) (sec)	39.7
LPCS injection valve stroke time (sec)	14.0
Delivered Coolant Flow Rate Versus Pressure	
Vessel to Torus ΔP (psid)	Flow rate for 1 pump (gpm)
0	5250
113	4000
265	0

* Relative to vessel zero.

Table 4.7 Automatic Depressurization System Parameters

Parameter	Value
Number of valves installed	7
Number of valves available*	5
Minimum flow capacity of available valves (Mlbm/hr at psig)	4.15 at 1112.4
Initiating Signals and Setpoints	
Water level (in) [†]	358
High drywell pressure (psig) [‡]	2
Time Delays	
ADS timer (delay time from initiating signal to time valves are open (sec))	121

* Only 5 valves are assumed operable in the analyses to support 1 ADSVOOS operation and the potential single failure of 1 ADS valve during the LOCA.

[†] Relative to vessel zero.

[‡] [

]

**Table 4.8 Available ECCS for
 Recirculation Line Break LOCAs**

Assumed Failure *	Recirculation Suction Break	Recirculation Discharge Break
	Systems Remaining ^{†, ‡, §}	Systems Remaining ^{‡, §}
DC power (i) (SF-BATT)	1LPCS + 3LPCI + ADS	1LPCS + 1LPCI + ADS
DC power (j)	2LPCS + 2LPCI + HPCI + ADS	2LPCS + HPCI + ADS
Diesel generator (i)	1LPCS + 3LPCI + HPCI + ADS	1LPCS + 1LPCI + HPCI + ADS
Diesel generator (j)	2LPCS + 2LPCI + HPCI + ADS	2LPCS + HPCI + ADS
LPCI injection valve (SF-LPCI)	2LPCS + 2LPCI + HPCI + ADS	2LPCS + HPCI + ADS
HPCI system (SF-HPCI)	2LPCS + 4LPCI + ADS	2LPCS + 2LPCI + ADS

* Failure of either DC power (i) or diesel generator (i) will result in the loss of one diesel generator (DG-1 or DG-2). The loss of DC power (i) will also result in the loss of the HPCI. The loss of DC power (j) or diesel generator (j) will result in the loss of one diesel generator (DG-3 or DG-4).

† Systems remaining, as identified in this table for recirculation suction line breaks, are applicable to other non-ECCS line breaks. For a LOCA from an ECCS line break, the systems remaining are those listed for recirculation suction breaks, less the ECCS in which the break is assumed.

‡ 1LPCI (1 pump into 1 loop) means one RHR pump operating in one LPCI loop, 2LPCI (2 pumps into 1 loop) means two RHR pumps operating in one loop, 3LPCI (3 pumps into 2 loops) means three RHR pumps operating in two loops, 4LPCI (4 pumps into 2 loops) means four RHR pumps operating in two loops.

§ Although HPCI is expected to be available for some events, no accident analysis mitigation credit is assumed for this system.

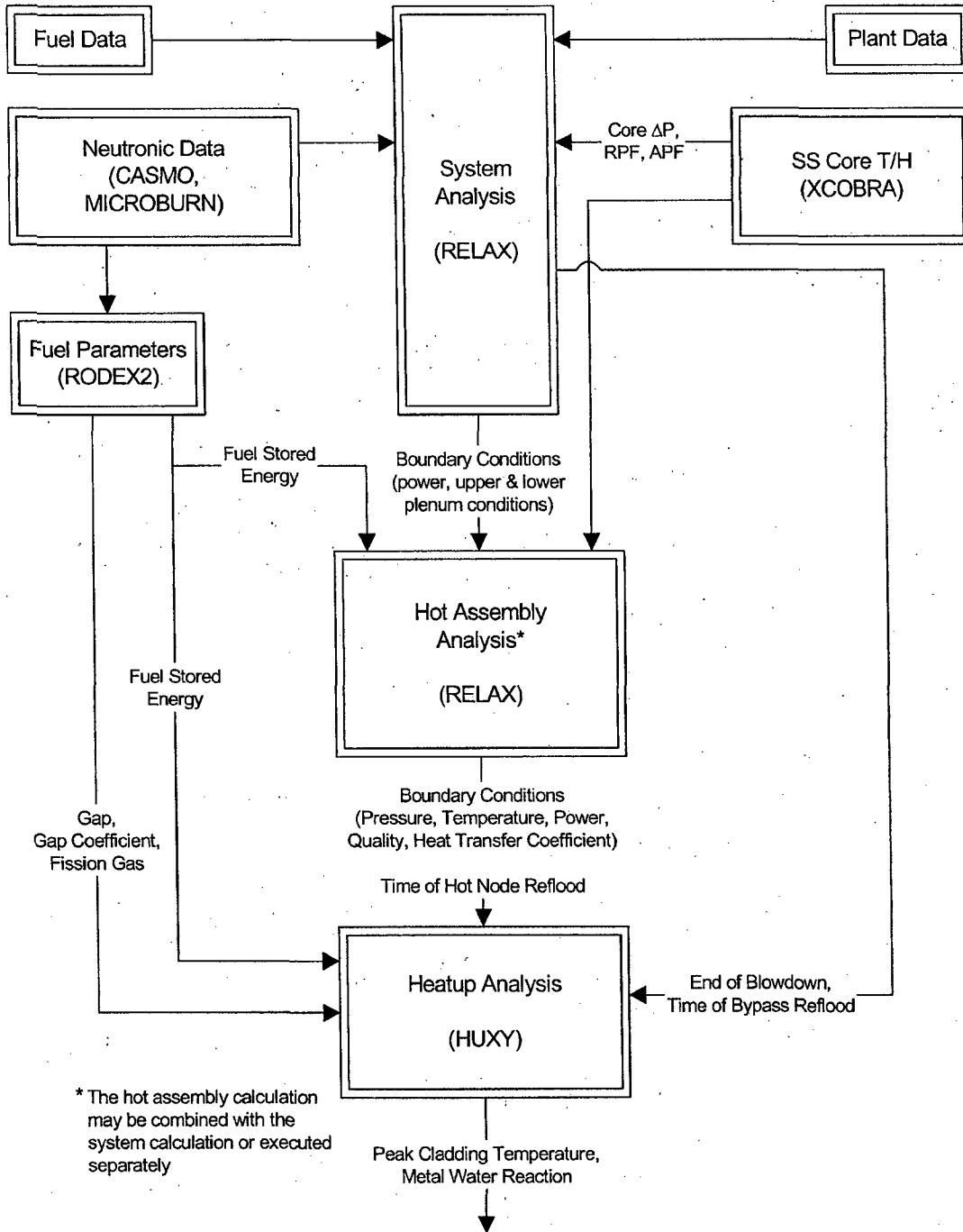

Figure 4.1 Flow Diagram for EXEM BWR-2000 ECCS Evaluation Model

[

]

Figure 4.2 RELAX System Model

[

]

**Figure 4.3 RELAX Hot Channel Model
Top-Peaked Axial**

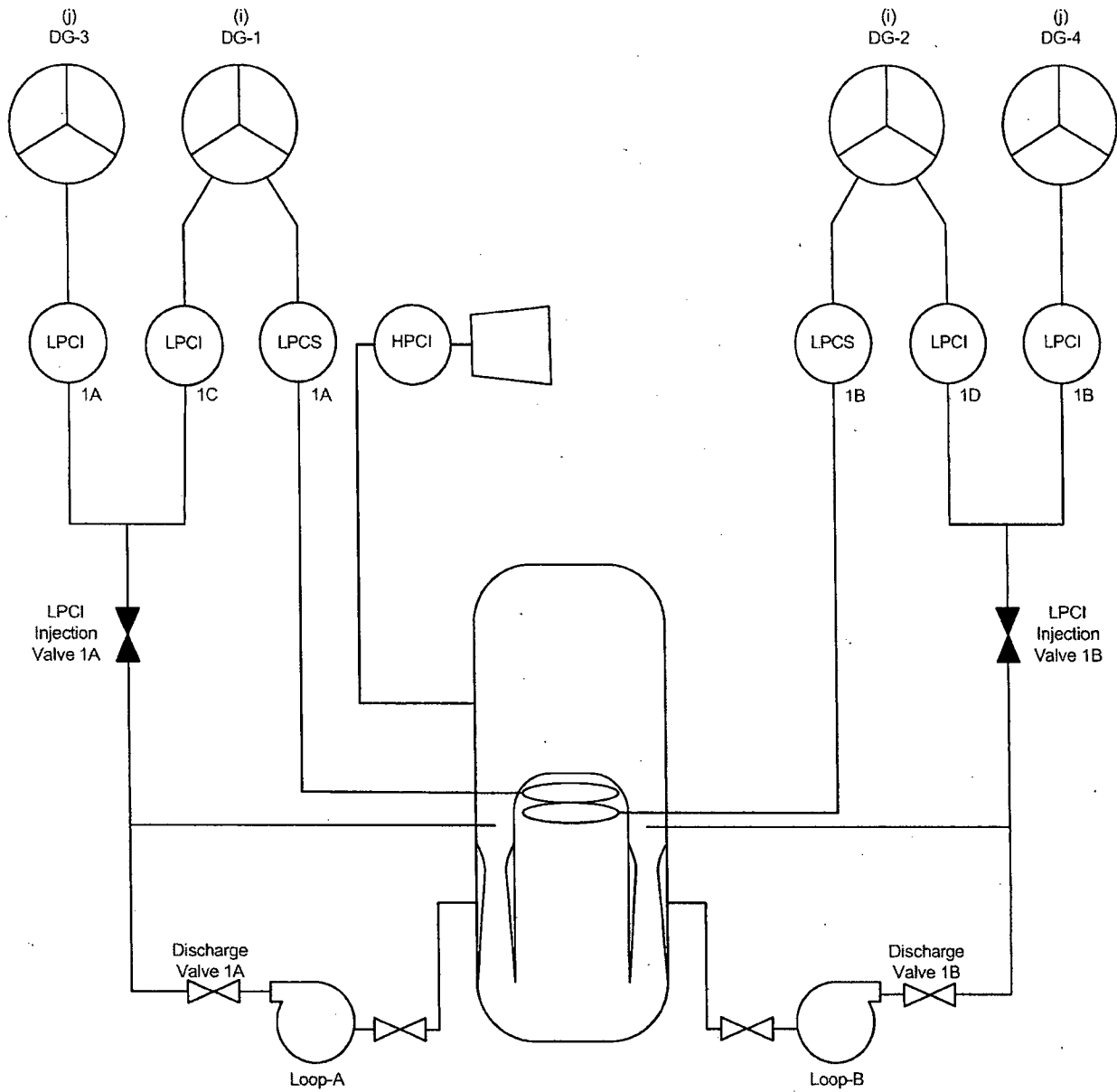

DG-3 Powers LPCI-1A, LPCI Injection Valve 1A and Discharge Valve 1A
 DG-4 Powers LPCI-1B, LPCI Injection Valve 1B and Discharge Valve 1B

Figure 4.4 ECCS Schematic

[

]

**Figure 4.5 Axial Power Distribution
in RELAX Calculation**

5.0 MAPLHGR Analysis Description and Results

An exposure-dependent MAPLHGR limit for ATRIUM-10 fuel is obtained by performing HUXY heatup analyses using results from the limiting LOCA analysis case identified in Reference 1. The break characteristics for the limiting analysis are summarized in Section 1.0. Table 5.1 shows event times for the analysis. The response of the reactor system is shown in Figure 5.1 to Figure 5.25. In the MAPLHGR analysis, the fuel rod stored energy is set to be bounding at all exposures and the RELAX hot channel peak power node is modeled at the highest MAPLHGR, which is 12.5 kW/ft for the ATRIUM-10 fuel.

Table 5.2 shows the MAPLHGR analysis results for the ATRIUM-10 fuel. The HUXY model of the ATRIUM-10 fuel is applied to obtain these results as described in Section 4.3. The HUXY analysis is performed at 5 GWd/MTU exposure intervals for assembly average planar exposures between 0 and 65 GWd/MTU and an ending exposure of 67 GWd/MTU. The MAPLHGR limits are provided for an assembly average planar exposure range which ensures appropriate limits are applied up to the monitored maximum assembly average and rod average exposure limits of 54 GWd/MTU and 60 GWd/MTU, respectively. The HUXY MAPLHGR input is consistent with the data in Figure 2.1. Exposure-dependent fuel rod data is provided from RODEX2 results and includes gap coefficient, hot gap thickness, cold gap thickness, gas moles, fuel rod plenum length, and spring relaxation time. This data is provided as a function of linear heat generation rate at each exposure analyzed.

The ATRIUM-10 limiting PCT is 1900°F at 0.0 GWd/MTU exposure. The maximum local MWR of 1.16% occurred at 0.0 GWd/MTU exposure. Analysis results show that the planar average MWR at the peak power plane is less than 0.50%. Since all other planes in the core are at lower power, the CMWR will be significantly less than 0.50%.

Figure 5.26 shows the cladding temperature of the ATRIUM-10 PCT rod as a function of time for the limiting break. The maximum temperature of 1900°F occurs at 174.3 seconds, the time of reflood of the hot node in the core. These results demonstrate the acceptability of the ATRIUM-10 MAPLHGR limit shown in Figure 2.1.

**Table 5.1 Event Times for Limiting Break
 0.8 DEG Pump Discharge SF-LPCI
 Top-Peaked Axial**

Event	Time (sec)
Initiate break	0.0
Initiate scram	0.6
Low-low liquid level, L2 (459 in)	5.5
Low-low-low liquid level, L1 (358 in)	8.2
Jet pump uncovers	9.4
Recirculation suction uncovers	16.9
Lower plenum flashes	16.1
Diesel generators started	15.0
LPCS high-pressure cutoff	59.8
Power at LPCS injection valves	27.8
LPCS valve pressure permissive	48.0
LPCS valve starts to open	49.0
LPCS valve open	63.0
LPCS pump at rated speed	39.7
LPCS flow starts	63.0
LPCS permissive for ADS	39.7
RDIV pressure permissive	56.5
RDIV starts to close	57.5
RDIV closed	94.5
Rated LPCS flow	87.7
Blowdown ends	87.7
ADS valves open	129.2
Bypass reflood	163.8
Core reflood	174.8
PCT	174.8

**Table 5.2 ATRIUM-10 MAPLHGR
 Analysis Results**

Average Planar Exposure (GWd/MTU)	MAPLHGR (kW/ft)	PCT (°F)	Local Cladding Oxidation (%)
0.0	12.5	1900	1.16
5.0	12.5	1874	1.01
10.0	12.5	1835	0.84
15.0	12.5	1823	0.78
20.0	12.0	1754	0.60
25.0	11.5	1695	0.48
30.0	11.0	1664	0.41
35.0	10.5	1617	0.32
40.0	10.0	1584	0.26
45.0	9.5	1550	0.21
50.0	9.0	1511	0.17
55.0	8.5	1466	0.14
60.0	8.0	1423	0.11
65.0	7.5	1367	0.08
67.0	7.3	1344	0.07
CMWR is <0.50% at all exposures.*			

* The planar average MWR for the peak power plane is <0.50% which supports the conclusion that the CMWR is less than 0.50%.

[

]

**Figure 5.1 Limiting Break
Upper Plenum Pressure**

[

]

**Figure 5.2 Limiting Break
Total Break Flow Rate**

[

]

**Figure 5.3 Limiting Break
Core Inlet Flow Rate**

[

]

**Figure 5.4 Limiting Break
Core Outlet Flow Rate**

[

]

**Figure 5.5 Limiting Break
Intact Loop Jet Pump Drive Flow Rate**

[

]

**Figure 5.6 Limiting Break
Intact Loop Jet Pump Suction Flow Rate**

[

**Figure 5.7 Limiting Break
Intact Loop Jet Pump Exit Flow Rate**

]

[

**Figure 5.8 Limiting Break
Broken Loop Jet Pump Drive Flow Rate**

]

[

]

**Figure 5.9 Limiting Break
Broken Loop Jet Pump Suction Flow Rate**

[

]

**Figure 5.10 Limiting Break
Broken Loop Jet Pump Exit Flow Rate**

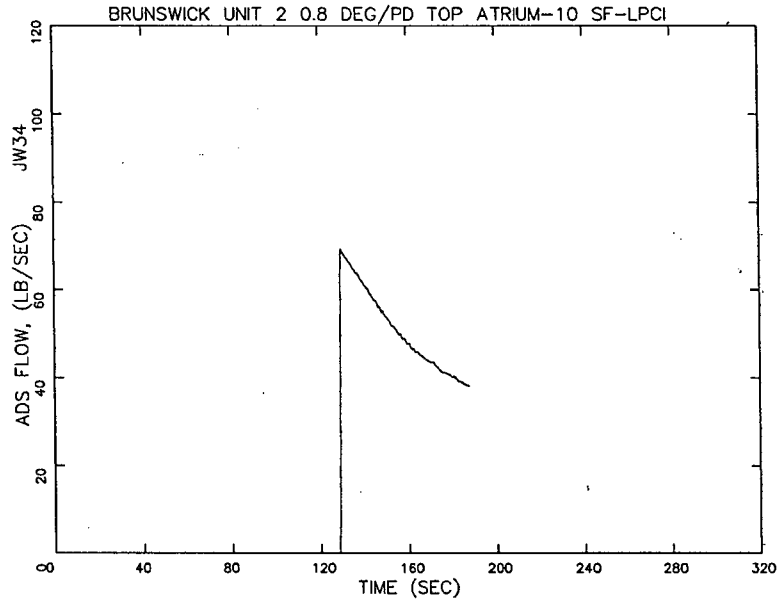

**Figure 5.11 Limiting Break
ADS Flow Rate**

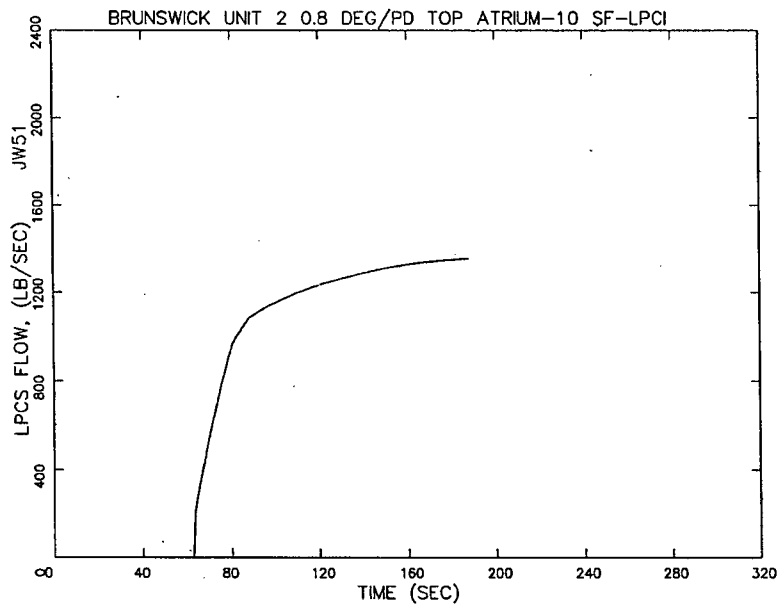

**Figure 5.12 Limiting Break
LPCS Flow Rate**

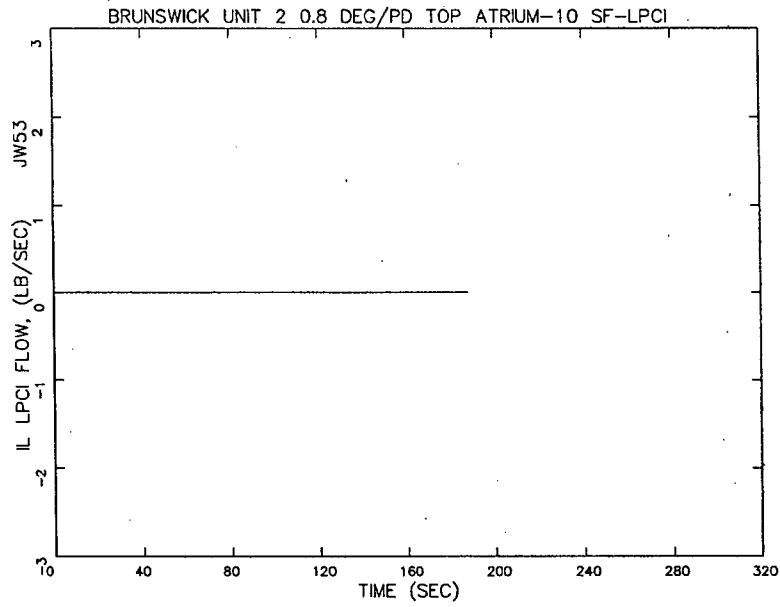

**Figure 5.13 Limiting Break
Intact Loop LPCI Flow Rate**

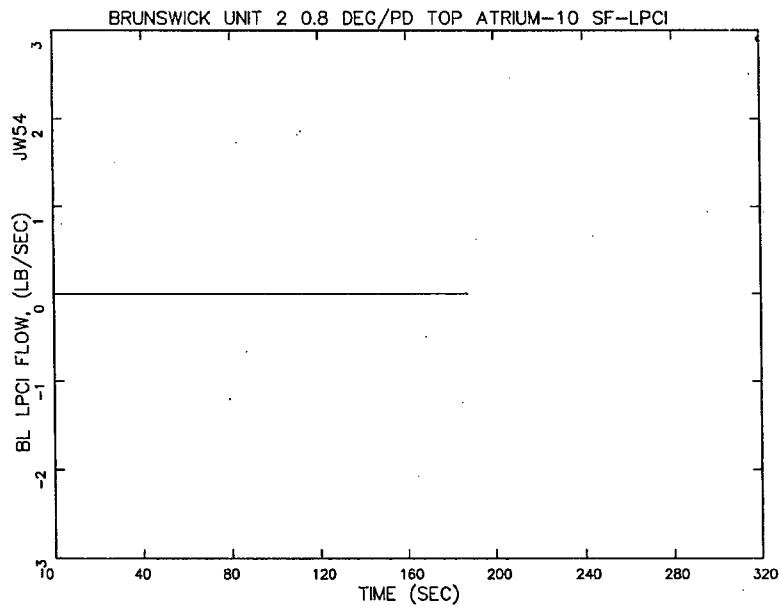

**Figure 5.14 Limiting Break
Broken Loop LPCI Flow Rate**

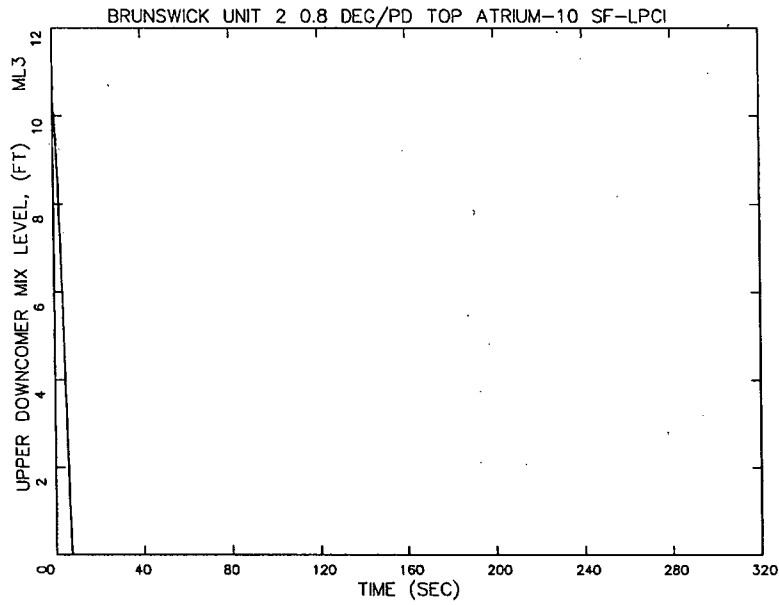

**Figure 5.15 Limiting Break
Upper Downcomer Mixture Level**

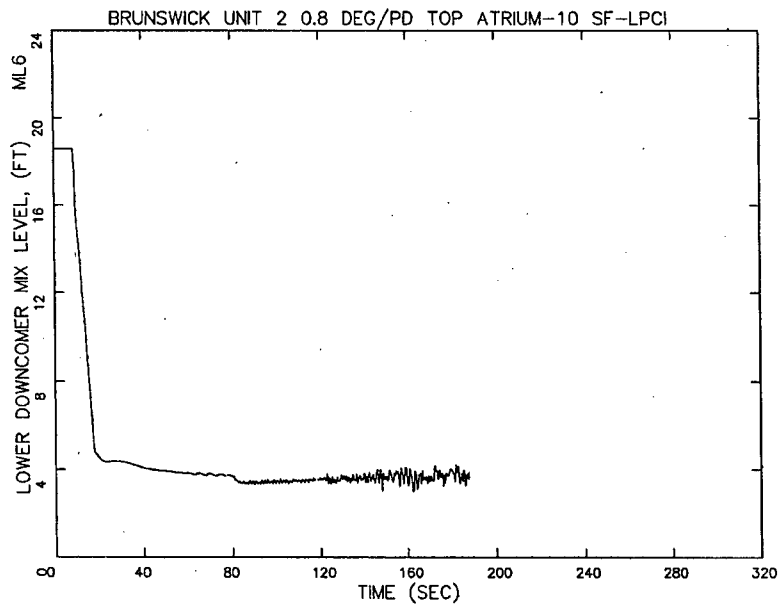

**Figure 5.16 Limiting Break
Lower Downcomer Mixture Level**

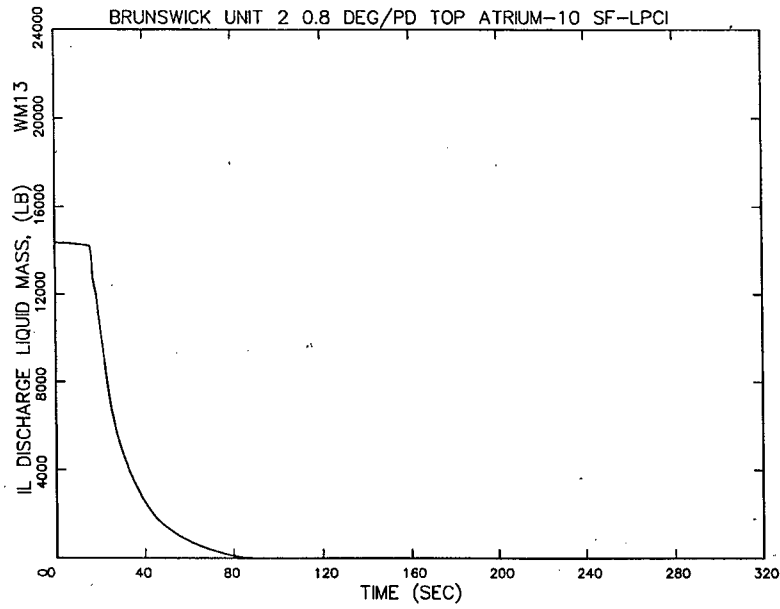

**Figure 5.17 Limiting Break
Intact Loop Discharge Line Liquid Mass**

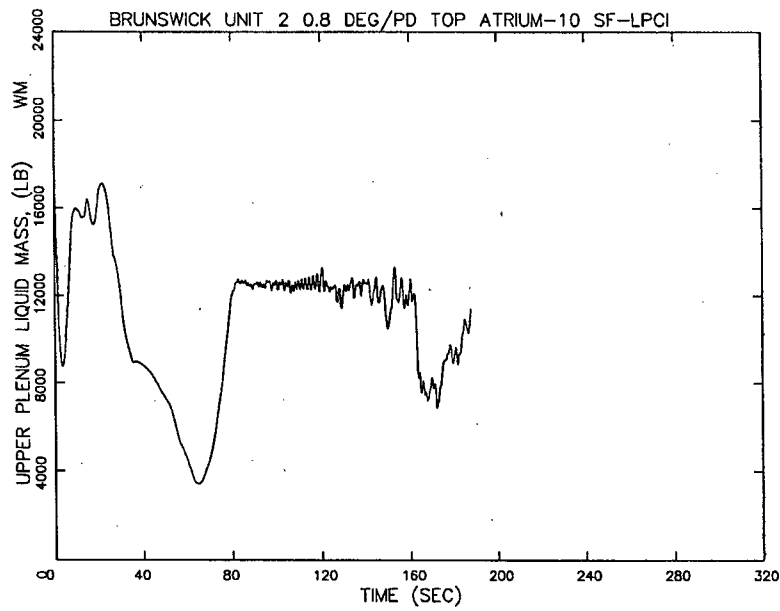

**Figure 5.18 Limiting Break
Upper Plenum Liquid Mass**

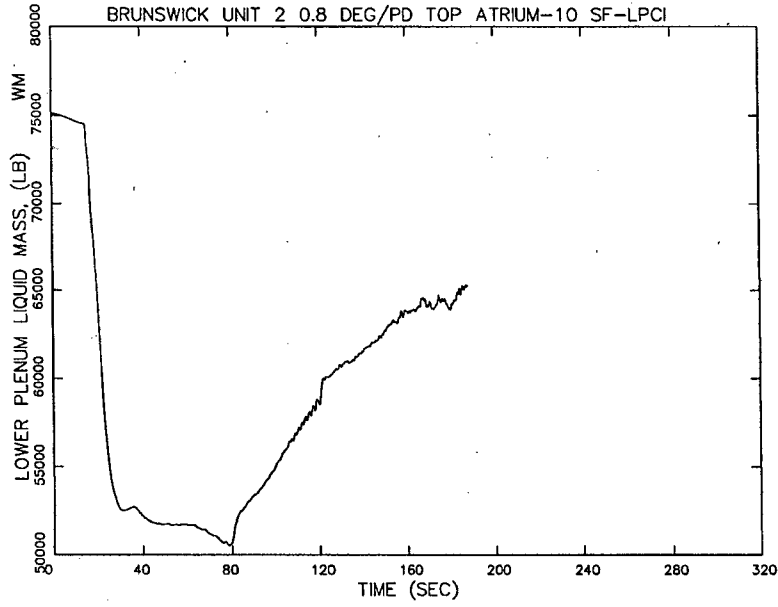

**Figure 5.19 Limiting Break
Lower Plenum Liquid Mass**

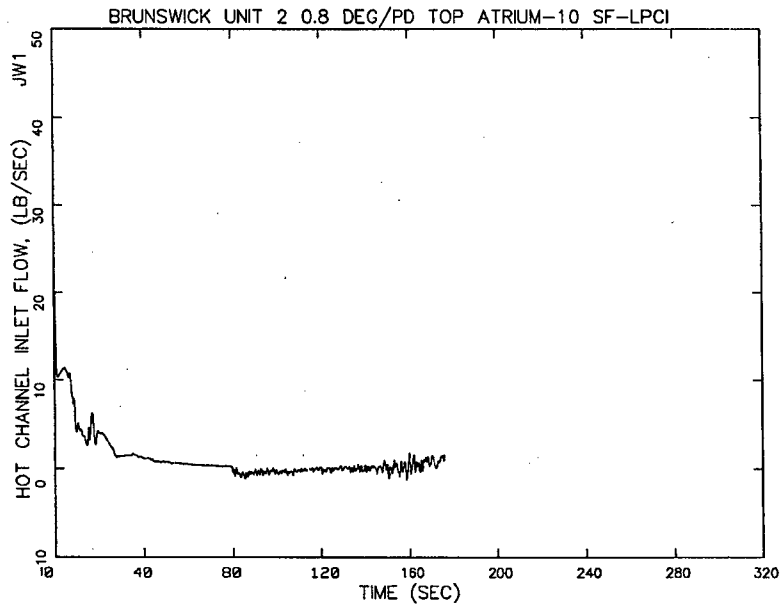

**Figure 5.20 Limiting Break
Hot Channel Inlet Flow Rate**

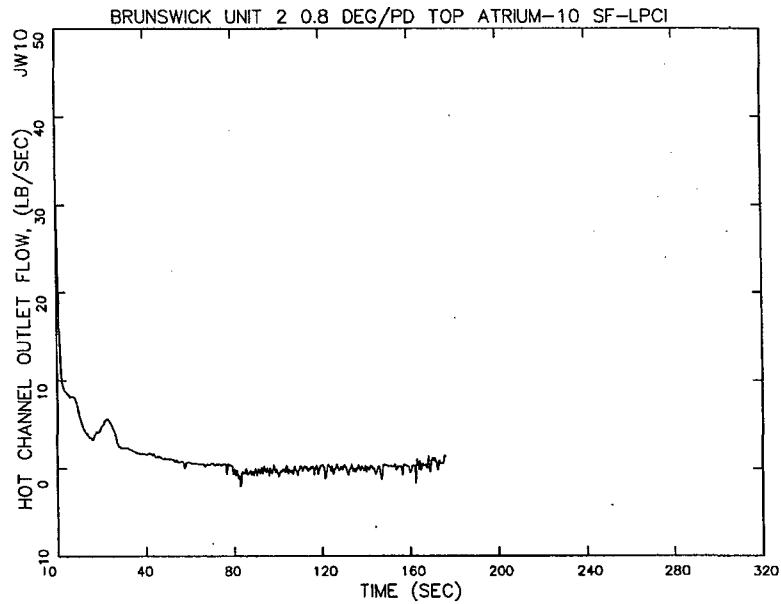

**Figure 5.21 Limiting Break
Hot Channel Outlet Flow Rate**

[

]

**Figure 5.22 Limiting Break
Hot Channel Coolant Temperature at the Hot Node at EOB**

[

]

**Figure 5.23 Limiting Break
Hot Channel Quality at the Hot Node at EOB**

[

]

**Figure 5.24 Limiting Break
Hot Channel Heat Transfer Coeff. at the Hot Node at EOB**

[

]

**Figure 5.25 Limiting Break
Hot Channel Reflood Junction Liquid Mass Flow Rate**

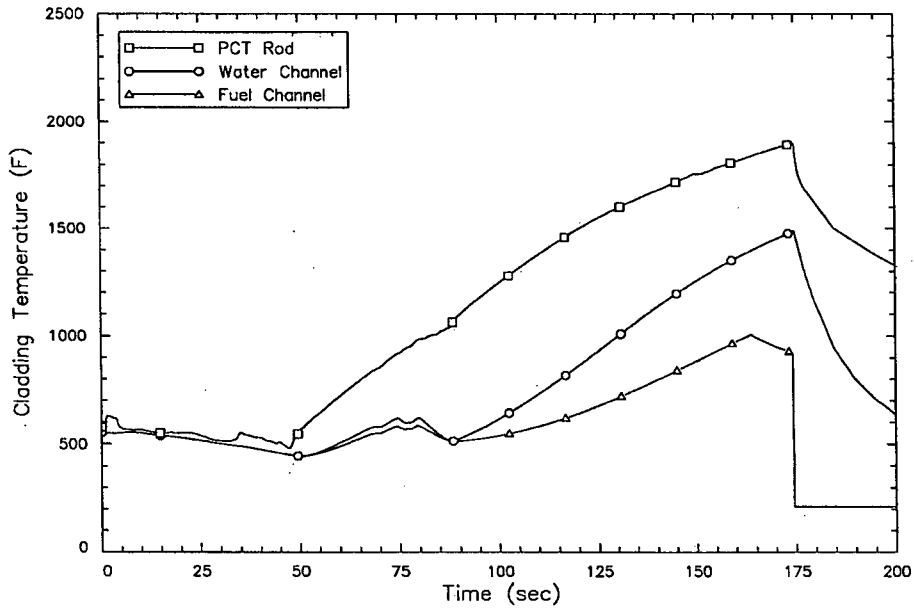

**Figure 5.26 Limiting Break
Cladding Temperatures**

6.0 Conclusions

The EXEM BWR-2000 Evaluation Model was applied to confirm the acceptability of the ATRIUM-10 MAPLHGR limit for Brunswick Units 1 and 2. The following conclusions were made from the analyses presented.

- The acceptance criteria of the Code of Federal Regulations (10 CFR 50.46) are met for operation at or below the ATRIUM-10 MAPLHGR limit given in Figure 2.1.
 - Peak PCT < 2200°F.
 - Local cladding oxidation thickness < 17%.
 - Total hydrogen generation < 1%.
 - Coolable geometry, satisfied by meeting peak PCT, local cladding oxidation, and total hydrogen generation criteria.
 - Core long-term cooling, satisfied by concluding core flooded to top of active fuel or core flooded to the jet pump suction elevation (Reference 1).
- The MAPLHGR limit is applicable for ATRIUM-10 full cores as well as transition cores containing ATRIUM-10 fuel.

7.0 References

1. ANP-2625(P) Revision 0, *Brunswick Units 1 and 2 LOCA Break Spectrum Analysis for ATRIUM™-10 Fuel*, AREVA NP, June 2007.
2. EMF-2361(P)(A) Revision 0, *EXEM BWR-2000 ECCS Evaluation Model*, Framatome ANP, May 2001.
3. XN-NF-81-58(P)(A) Revision 2 and Supplements 1 and 2, *RODEX2 Fuel Rod Thermal-Mechanical Response Evaluation Model*, Exxon Nuclear Company, March 1984.
4. XN-CC-33(P)(A) Revision 1, *HUXY: A Generalized Multirod Heatup Code with 10 CFR 50 Appendix K Heatup Option Users Manual*, Exxon Nuclear Company, November 1975.
5. XN-NF-82-07(P)(A) Revision 1, *Exxon Nuclear Company ECCS Cladding Swelling and Rupture Model*, Exxon Nuclear Company, November 1982.
6. EMF-2292(P)(A) Revision 0, *ATRIUM™-10: Appendix K Spray Heat Transfer Coefficients*, Siemens Power Corporation, September 2000.