

SEABROOK STATION UFSAR	TECHNICAL SPECIFICATIONS Preliminary Technical Specifications	Revision 8 Section 16.1 Page 1
---------------------------------------	--	--------------------------------------

16.1 PRELIMINARY TECHNICAL SPECIFICATIONS

Refer to the Seabrook PSAR.

SEABROOK STATION UFSAR	TECHNICAL SPECIFICATIONS Final Technical Specifications	Revision 8 Section 16.2 Page 1
---------------------------------------	--	--------------------------------------

16.2 FINAL TECHNICAL SPECIFICATIONS

Refer to Technical Specifications, Seabrook Station, Unit I, Docket No. 50-443, Appendix A to License No. NPF-86, March 1990.

SEABROOK STATION UFSAR	TECHNICAL SPECIFICATIONS Technical Specification Improvement Program	Revision 11 Section 16.3 Page 1
---------------------------------------	---	---------------------------------------

16.3 TECHNICAL SPECIFICATION IMPROVEMENT PROGRAM

The Technical Specification Improvement Program for Seabrook Station involves the relocation of certain technical specifications into other licensee-controlled documents. These documents are the UFSAR and the Offsite Dose Calculation Manual (ODCM). The majority of the technical specifications are relocated into Section 16.3 of the UFSAR.

In order to facilitate routine day-to-day use, Section 16.3 of the UFSAR has been relocated into the Technical Requirements Manual (TRM). The TRM contains information that would otherwise be contained in Section 16.3 of the UFSAR. The Core Operating Limits Report (COLR) is also located in the TRM. The COLR section of the TRM is submitted to the NRC upon each update. The information is not duplicated in Section 16.3 of the UFSAR to eliminate the inherent problems associated with maintaining accurate information in duplicate locations.

Changes to the TRM are processed in accordance with the UFSAR change guidance contained in Chapter 6 of the Regulatory Compliance Manual (NARC) and are submitted to the NRC as part of the UFSAR update required by 10CFR50.71(e).

Changes to the ODCM are processed and submitted to the NRC through administrative control processes described in Technical Specification 6.13.

16.3.1 References

1. NRR-Office Instruction, Lic-100, Rev. 00, March 2001, Appendix B, Chapter 3, Section 3.1.2.
2. NRC letter, dated August 8, 1991, Gordon E. Edison, Senior Project Manager to T.C. Feigenbaum, President and Chief Executive Officer, New Hampshire Yankee.

SEABROOK STATION UFSAR	<p style="text-align: center;">QUALITY ASSURANCE</p> <p style="text-align: center;">Quality Assurance During Design and Construction</p>	Revision 8 Section 17.1 Page 1
---------------------------------------	--	--------------------------------------

17.1 QUALITY ASSURANCE DURING DESIGN AND CONSTRUCTION

17.1.1 Yankee Atomic Electric Company

17.1.1.1 Organization

a. Authority, Responsibilities, and Duties

The Public Service Company of New Hampshire (PSNH) retains overall responsibility for Quality Assurance, and delegated to the Yankee Atomic Electric Company (YAEC) the responsibility for the development, execution, and administration of the quality assurance program which involved quality-related activities during the design, procurement, construction, startup and preoperational testing phases for safety-related structures, components and systems. PSNH's New Hampshire Yankee Division (NHY) oversaw the day-to-day activities to meet PSNH's overall responsibility.

Yankee Atomic Electric Company established the organizational structure shown in Figure 13.1-2 for the design, procurement and construction phases of the Seabrook (SB) Project. This figure shows the lines of authority and communication as they relate to the Seabrook organization. Figure 17.1-1 and Figure 17.1-2 depict the overall intercompany project quality assurance and project organizations showing the major organizations involved and how they interrelate. For additional details, refer to Section 13.1.

YAEC delegated to the Engineer-Constructor, United Engineers & Constructors Inc. (UE&C), and to the nuclear steam system supplier, Westinghouse Electric Corporation-Water Reactor Divisions (WRD), administration and execution of large portions of the quality assurance program associated with the design, procurement and installation of safety-related structures and equipment, as defined in Table 17.1-1, Table 17.1-2, and Table 17.1-3. UE&C and WRD and their vendors and subcontractors who were responsible for safety-related components and structures, were required to have quality assurance programs consistent with the requirements of 10 CFR 50, Appendix B, and of this program.

Quality disputes between NHY, YAEC, UE&C, and Westinghouse that could be resolved at the working level were brought progressively to the attention of increasingly higher levels of line management of each organization with ultimate resolution, if required, by the PSNH Chairman and Chief Executive Officer.

SEABROOK STATION UFSAR	<p style="text-align: center;">QUALITY ASSURANCE</p> <p style="text-align: center;">Quality Assurance During Design and Construction</p>	Revision 8 Section 17.1 Page 2
---------------------------------------	--	--------------------------------------

The responsibilities of YAEC and other key project management personnel are outlined below:

The Director of Quality Assurance who reported to the YAEC President was responsible for establishing policies under which the Yankee Quality Assurance organization works, and under which contractors comply. He approved the Seabrook Station Quality Assurance Manual which governed all YAEC program activities and received copies of correspondence and reports generated by the Quality Assurance Department (QAD). He evaluated and reported to the President on the effectiveness of the Quality Assurance Program. He reported on a quarterly basis to the NHY management to keep them advised of the program status. He coordinated the activities and program direction of quality assurance during design, construction and certain phases of startup operation to maintain consistency of the program and continuity of the effort.

The Construction Quality Assurance Manager (QAM) who reported to the Director of Quality Assurance, was responsible for the direction and supervision of work performed by the Construction Quality Assurance Group staff, at both the corporate office and at the plant site, and by consultants hired to supplement this staff. Offsite personnel (Home Office QA Engineers) performed staff functions, i.e., developed QA programs and procedures, reviewed technical and QA documentation submittals, provided training and indoctrination and performed audit and/or surveillance functions internally as well as over contractors, constructors, subcontractors and suppliers. Onsite personnel performed QA line functions, i.e., planned and developed verification procedures and controls, performed surveillance activities over constructors and subcontractors and reviewed contractor and subcontractor implementing procedures. Qualification requirements for the position responsible for establishing and implementing the Seabrook Station QA Program were:

1. Graduate of an accredited college or university, with a technical degree.
2. Ten years minimum experience consisting of:
 - (a) Significant experience in a utility, nuclear, heavy construction or heavy equipment industry.
 - (b) Experience in development and implementation of quality assurance programs, plans and procedures.
3. Familiarity with 10 CFR 50 and applicable codes and standards.

SEABROOK STATION UFSAR	<p style="text-align: center;">QUALITY ASSURANCE</p> <p style="text-align: center;">Quality Assurance During Design and Construction</p>	<p style="text-align: center;">Revision 8 Section 17.1 Page 3</p>
---------------------------------------	--	---

4. Knowledge of inspection and nondestructive testing techniques.
5. Ability to plan, organize and administer an engineering activity.
6. Ability to provide effective written and oral communication.
7. Ability to maintain a professional working relationship with contractors, suppliers, government agencies and the public.

The QAM was responsible for the preparation, maintenance and distribution of the Seabrook Station Quality Assurance Manual. He was also responsible for: (1) providing technical direction and administrative control of the construction QA staff, (2) verifying completeness and adequacy of YAEC Quality Assurance Program documents used to define program scope, responsibilities and methods, (3) reviewing of contractor specifications, procurement documents, and quality assurance programs and quality assurance manuals for compliance with quality assurance requirements of the Quality Assurance Program, (4) developing and implementing YAEC surveillance and audit systems to ensure implementation of the Quality Assurance Program by YAEC and its contractors and subcontractors, (5) insuring that YAEC program activities and documentation are completed prior to plant operation, (6) ensuring timely and appropriate communications regarding conditions requiring corrective action, including those at the construction site or in vendor shops, (7) identifying quality problems, initiating, recommending, or providing solutions, and verifying implementation of solutions, (8) communications regarding information required mutually by the QAD and other groups for the performance of their respective functions, and (9) assuring that QAD personnel have direct access to such levels of management as may be necessary to carry out their responsibilities. YAEC Personnel performing quality assurance duties were qualified by virtue of their experience or they received instruction or other training, as required, to ensure adequate knowledge and understanding for the performance of their duties. In preparation for the initial assignments to review or audit without direct supervision, personnel were instructed in the governing procedures, and they performed reviews or audits under qualified supervision. Personnel were given in-house training and attended courses, as necessary, to qualify them for assignments or to upgrade their qualifications in such areas as nondestructive testing, welding, code requirements and design control and audit procedures. The qualifications and performance of personnel were evaluated annually. The training program is described in the Seabrook Station Assurance Manual. The Quality Assurance Department is staffed with personnel knowledgeable and qualified in the following:

SEABROOK STATION UFSAR	<p style="text-align: center;">QUALITY ASSURANCE</p> <p style="text-align: center;">Quality Assurance During Design and Construction</p>	<p style="text-align: center;">Revision 8 Section 17.1 Page 4</p>
---------------------------------------	--	---

1. SNT-TC-IA Levels II and III
2. Quality Assurance for mechanical equipment
3. Quality Assurance for electrical equipment
4. Quality Assurance for instrumentation and control equipment
5. Quality Assurance for construction activities.

Personnel qualifications to review design and procurement documents and QA programs and to perform audits were reviewed annually at which time a determination was made for the need for further training. Responsibilities and duties were assigned to personnel having qualifications required for the assignments. The QAM, and personnel reporting to him, had the authority to order that work be stopped on any operation they found being performed contrary to approved procedures, specifications, instructions, or drawings.

The NHY Construction Director reported to the Senior Vice President of NHY and was responsible for managing all field personnel, thus ensuring that all construction-related activities are properly completed. The Construction Director was charged with the responsibility for completing the field construction activities in accordance with corporate guidelines, project planner and scheduler, project objectives, engineering drawings, specification, instructions, and procedures.

The Construction Director was responsible for performing the full range of management functions, including organizing, staffing, directing, leading and controlling the work of the assigned field personnel and contractors, as well as serving as the focal point for all groups involved with the construction-related work at the jobsite, both within and outside New Hampshire Yankee.

The Director of Engineering and Licensing reported to the Senior Vice President (NHY) and was responsible for providing direction and selected review of all project engineering, design, and NRC licensing work performed; for ensuring that the project engineering organization receives consistent direction and guidance, ensuring consistent and acceptable quality throughout the engineering organization; and for evaluating the impact of regulatory changes to the project.

The Startup Test Group Manager, who reported to the NHY Vice President - Nuclear Production was responsible for managing and providing overall direction for the initial test program which included integrated systems preoperational tests and initial startup tests. He ensured that applicable portions of the Seabrook

SEABROOK STATION UFSAR	<p style="text-align: center;">QUALITY ASSURANCE</p> <p style="text-align: center;">Quality Assurance During Design and Construction</p>	<p style="text-align: center;">Revision 8 Section 17.1 Page 5</p>
---------------------------------------	--	---

Station Quality Assurance Program were applied in activities related to the initial test program.

Consultants retained by YAEC or NHY as necessary to supplement the work of the YAEC quality assurance organization were required to comply with this program. Their work was reviewed on a continuing basis by the YAEC individual responsible for their scope of work.

The quality assurance organizations of companies performing quality-related activities covered by this program were required to be structured so that they had the required authority and organizational freedom to identify problems; to initiate, recommend, or provide solutions; to verify implementation of solutions; and stop work or control further processing, use, or installation of a nonconforming item or unsatisfactory condition until proper dispositioning had occurred. The personnel performing quality assurance activities are independent of the individual or group responsible for performing the activity.

The UE&C organization is described in Topical Report No. UEC-TR001. The WRD organization is described in the Westinghouse WRD Quality Assurance Plan (WCAP-8370).

The interface between YAEC, UE&C and WRD is shown in Figure 17.1-2. The YAEC Construction Quality Assurance Manager had direct project authority over the WRD QA Manager and the UE&C Reliability and QA Manager regarding quality-related activities. YAEC reviewed and concurred with all quality-related procedures, programs, plans, etc., that were generated by the AE (UE&C). YAEC reviewed and concurred with the Westinghouse QA Topical Report and reviewed department procedures in the process of auditing Westinghouse performance.

The contractors were responsible for the review and approval of their supplier and subcontractor quality-related documents. The adequacy of the contractors' reviews was verified by YAEC audit and/or surveillance either at contractors' facilities or at the facilities of supplier and subcontractors. Audit and/or surveillance of contractors (AE) and suppliers was performed by YAEC home office personnel. Surveillance of subcontractors at the construction site was performed by the YAEC QA representatives assigned to the site. Audit at the construction site was performed by YAEC home office QA personnel.

SEABROOK STATION UFSAR	<p style="text-align: center;">QUALITY ASSURANCE</p> <p style="text-align: center;">Quality Assurance During Design and Construction</p>	<p style="text-align: center;">Revision 8 Section 17.1 Page 6</p>
---------------------------------------	--	---

b. Responsible Management Levels

Public Service Company of New Hampshire, had overall responsibility for quality assurance on the Seabrook Project. The Chief Executive Officer of PSNH delegated to YAEC the responsibility for establishment and implementation of the Quality Assurance Program during construction, startup, and preoperation testing. He, or his staff, maintained cognizance of and evaluated the program activities in the following manner.

1. Reviewed and approved the YAEC Quality Assurance Program as described in the Seabrook Station Quality Assurance Manual.
2. Participated in major QA decisions and program changes.
3. Received copies of all YAEC audit reports (internal and external) pertaining to the Project. He received monthly the Status of Outstanding Items indicating the status of audit findings.
4. Participated on a quarterly basis in selected external audits by YAEC to assess YAEC performance in contractor activities. As an alternate to participating in the audit, he reviewed YAEC external audit reports. The diversity of audits were sufficient to ensure that YAEC complied with the requirements of Subsection 17.1.1.18. The NHY member of the audit team acted as an observer to assess the performance of the YAEC auditor(s).
5. Participated on a quarterly basis in selected internal audits of YAEC to assess YAEC performance in QA activities. Participating applicant personnel were required to recommend actions to utility management over and above those recommended by YAEC if deemed necessary. The diversity of audits were sufficient to ensure that YAEC complied with the requirements of Subsection 17.1.1.18. The NHY member of the audit team acted as an observer to assess the performance of the YAEC auditor(s).
6. Performed management audits of YAEC Construction Quality Assurance performance. The management audits were conducted annually using approved checklists and followed a pre-established schedule ensuring compliance with the program.
7. Reviewed quarterly evaluations of QA program activities.

SEABROOK STATION UFSAR	<p style="text-align: center;">QUALITY ASSURANCE</p> <p style="text-align: center;">Quality Assurance During Design and Construction</p>	<p style="text-align: center;">Revision 8 Section 17.1 Page 7</p>
---------------------------------------	--	---

8. Received copies of all YAEC correspondence with contractors relating to QA program activities.

Within YAEC, the Director of Quality Assurance was responsible for coordination of the program activities and for the overall effectiveness of the program. The responsibility for completeness of the program requirements, issuance and maintenance of the Seabrook Station Quality Assurance Manual, and compliance with program requirements was delegated to the YAEC Construction Quality Assurance Manager. An audit of the activities of the YAEC Construction Quality Assurance was performed under the cognizance of the YAEC President and NHY Management. The audit team included at least one representative from the applicant's management.

The duties and responsibilities of the YAEC Director of Quality Assurance and the YAEC Construction Quality Assurance Manager (QAM) are described in Subsection 17.1.1.1a.

c. Scope of Delegation of Work

YAEC delegated to the Project architect-engineers, United Engineers & Constructors Inc. (UE&C), and to the supplier of the Nuclear Steam Supply System, Westinghouse Electric Corporation (WRD) administration and execution of large portions of the quality assurance program associated with the design, procurement and installation of safety-related equipment as defined in Table 17.1-1, Table 17.1-2 and Table 17.1-3 of this program. Procurement of safety-related equipment was performed by either UE&C or Westinghouse under the provisions of their topical reports and QA programs. These were reviewed and concurred upon by YAEC personnel. Compliance to the aforementioned is ensured via a system of audits performed by YAEC Home Office personnel who also reviewed the UE&C and Westinghouse in-house departmental procedures. UE&C and WRD, and their vendors and subcontractors who were responsible for safety-related components or structures, were required to have quality assurance programs consistent with the requirements of 10 CFR 50 Appendix B, and of this program.

The UE&C and WRD quality assurance programs were extensions of the YAEC program and as such were reviewed and accepted by YAEC. The structure of the UE&C quality assurance organization is described in the UE&C Quality Assurance Programs (Topical Report No. UE&C-TR-001) and referenced in Subsection 17.1.2 of this Updated FSAR. The structure of the WRD quality assurance organization is described in the Westinghouse NES Division's Quality

SEABROOK STATION UFSAR	<p style="text-align: center;">QUALITY ASSURANCE</p> <p style="text-align: center;">Quality Assurance During Design and Construction</p>	Revision 8 Section 17.1 Page 8
---------------------------------------	--	--------------------------------------

Assurance Plan Topical Report (WCAP-8370) and referenced in Subsection 17.1.3 of this Updated FSAR. Both Topical Reports were reviewed and approved by the Nuclear Regulatory Commission.

Conformance to approved requirements and programs was ensured through close liaison between the Project Managers of YAEC, NHY, WRD and UE&C and between their quality assurance organizations. Figure 17.1-2 depicts the managerial and quality assurance lines of authority, audit and communication between YAEC, NHY, WRD and UE&C and within these organizations. It also depicts responsibility to audit vendors and manufacturing divisions.

YAEC maintained control of contractor and internal quality-related activities principally by means of an audit and surveillance program which involved audits, surveys, investigations and reviews by the YAEC Project staff, Engineering, Quality Assurance, and Site Quality Assurance. Interface between YAEC, UE&C and WRD is depicted in Figure 17.1-1 as is the line of authority over the contractors to ensure necessary coordination and control of the Quality Assurance Program.

17.1.1.2 Quality Assurance Program

In order to ensure overall implementation of the quality assurance requirements, YAEC developed a program to cover quality-related activities during design, purchasing, fabrication, construction, and preoperational testing which affected those structures, systems and components that were necessary to ensure the integrity of the reactor coolant pressure boundary, the capability to shut down the reactor and maintain it in a safe shutdown condition and the capability to prevent or mitigate the consequences of accidents which could result in potential offsite exposures in excess of the guideline exposures indicated in Nuclear Regulatory Commission (NRC) Regulations.

a. Compliance with Requirements

In 1973 the Project made a commitment to comply with the requirements of "Guidance on Quality Requirements During Design and Procurement Phase of Nuclear Power Plants" (WASH-1283). As the ANSI standards referenced in WASH-1283, and its revision, were published, the program was updated to incorporate the most current requirements.

The YAEC quality assurance program imposed on the major suppliers of equipment and services, Westinghouse (WRD) and United Engineers & Constructors Inc. (UE&C), the requirement to establish similar programs for their internal operations and, in turn, to impose applicable portions on their programs

SEABROOK STATION UFSAR	<p style="text-align: center;">QUALITY ASSURANCE</p> <p style="text-align: center;">Quality Assurance During Design and Construction</p>	Revision 8 Section 17.1 Page 9
---------------------------------------	--	--------------------------------------

on their suppliers of safety-related materials, components, equipment or services. The WRD and UE&C programs were considered extensions of the YAEC program and as such, were subject to review, audit and approval by YAEC. UE&C was responsible for site construction coordination. Subcontractors providing safety-related items/services were required to implement quality assurance programs which were consistent with the YAEC program. UE&C review and approval was required for the subcontractor programs.

WRD as supplier of the Nuclear Steam Supply System (NSSS), presented its program in the Westinghouse WRD Divisions Quality Assurance Plan (WCAP-8370), and UE&C, the architect-engineer for this project, presented its program in the UE&C Quality Assurance Program (Topical Report No. UEC-TR-001). These programs were in effect and YAEC performed audits to ascertain WRD and UE&C compliance.

b. Safety-Related Structures, Systems, and Components

The safety-related structures, systems, and components listed in Table 17.1-1, Table 17.1-2, and Table 17.1-3 of this Updated FSAR were within the scope of the program. The contractors responsible for design and procurement were denoted in the table.

c. QA Program Schedule

All phases of the QA program were established at the earliest practical time consistent with the schedule for accomplishing activities affecting quality for the project. YAEC QAD reviewed contractor quality assurance procedures applicable to safety-related activities and performed audits or reviews, as required, to ensure implementation. Procedures concerning design and procurement activities were completed, reviewed and approved prior to that phase of the project. Construction procedures were prepared prior to the start of any quality-related activities at the site. Quality-related activities such as program and procedure reviews, specification reviews, procurement document reviews which were initiated prior to the submittal of the FSAR, were performed in accordance with approved procedures. Safety-related site studies (i.e., meteorology, geology) were performed in accordance with written approved procedures and were audited by YAEC or its agent(s).

SEABROOK STATION UFSAR	<p style="text-align: center;">QUALITY ASSURANCE</p> <p style="text-align: center;">Quality Assurance During Design and Construction</p>	Revision 8 Section 17.1 Page 10
---------------------------------------	--	---------------------------------------

Assurance by YAEC that these programs were properly implemented was accomplished by:

1. YAEC reviewed contractor QA programs to ensure compliance with the applicable criteria of 10 CFR 50, Appendix B
2. Audit programs conducted by YAEC and its contractors
3. YAEC's participation in periodic audits conducted by WRD and UE&C
4. Surveillance and audits at the construction site by YAEC Quality Assurance representatives.

d. Program Documentation

The YAEC Quality Assurance Program is described in the Seabrook Station Quality Assurance Manual. The preface to the Manual imposes the quality assurance program requirements upon all personnel and organizations performing quality-related activities. The procedures utilized by YAEC to satisfy the applicable requirements of 10 CFR 50, Appendix B, are shown in Table 17.1-4 and Table 17.1-5.

e. Program Policies

It is the policy of YAEC to provide a program to ensure the highest degree of integrity for safety-related equipment, structures and systems and with the criteria contained in 10 CFR 50, Appendix B and WASH-1283, YAEC included in this program those planned and systematic actions necessary to provide adequate confidence that the equipment, structures, and systems will perform satisfactorily in service to ensure a safe and reliable plant.

Should any disputes arise between YAEC departments, they were resolved, wherever possible, by the heads of the departments involved. If resolution was not possible at this level, the differences were presented to management for settlement. In either case, the resolution was documented.

f. Personnel Training

All activities affecting quality were performed by suitably trained personnel. Each YAEC department whose activities were discussed in the Updated FSAR prepared documents detailing the scope of its training program including a schedule for implementation and identifying the individuals by job description or

SEABROOK STATION UFSAR	<p style="text-align: center;">QUALITY ASSURANCE</p> <p style="text-align: center;">Quality Assurance During Design and Construction</p>	<p style="text-align: center;">Revision 8 Section 17.1 Page 11</p>
---------------------------------------	--	--

title or groups required to attend the sessions. Indoctrination and training programs ensured that:

1. Personnel responsible for performing quality activities were instructed as to the purpose, scope, and implementation of the quality-related manuals, instructions and procedures;
2. Personnel performing quality-related activities were trained and qualified in principles and techniques of the activity being performed;
3. Appropriate training procedures were established;
4. Personnel were made aware of quality-related policies, manuals, and procedures that were mandatory requirements which must be implemented and enforced.

The measures which ensure that the YAEC indoctrination and training program defined the scope, objective and method of implementing the program and maintain proficiency of personnel include:

1. Section 17.1 of the Updated FSAR details the program objectives, scope and methods as required by the NRC Standard Format and Content of Safety Analysis Reports for Nuclear Power Plants. The description meets the criteria of 10 CFR Part 50 Appendix B and of the NRC Standard Review Plan. The implementing program was prepared by the Construction Quality Assurance Manager and was approved by the YAEC Director of Quality Assurance.
2. Establishment of detailed YAEC departmental training programs which comply with FSAR commitments.
3. Auditing of departments performing quality affecting activities. The Quality Assurance Department performed the audits of other YAEC departments and it in turn was audited by NHY. During audits, the degree of compliance with policies and procedures was established and compliance with Project commitments was confirmed. Personnel become informed on the scope of Project technical and QA commitments by reviewing the FSAR and applicable referenced documents. They were instructed in the objectives, scope and details of manuals and instructions defining the YAEC control measures for work within individual departments and for interfacing, by both attendance at group indoctrination sessions conducted by QA personnel and by departmental

SEABROOK STATION UFSAR	<p style="text-align: center;">QUALITY ASSURANCE</p> <p style="text-align: center;">Quality Assurance During Design and Construction</p>	<p style="text-align: center;">Revision 8 Section 17.1 Page 12</p>
---------------------------------------	--	--

supervision, meetings and directives. Special training in areas such as nondestructive testing, Boiler and Pressure Vessel Code, auditing and documentation was provided as required. The scope, objectives and methods employed to indoctrinate and train personnel were defined in departmental procedures. Assignments of work performed without direct supervision were made only to individuals who demonstrated that they were qualified, based on experience or training, to perform the tasks assigned.

Proficiency was maintained through performance of work in accordance with established control measures, by reviewing and commenting on drafts of standards and Regulatory Guides, and by participating in technical society activities, including codes and standards committee activities. The performance of individuals was reviewed at least yearly by Department Heads to ensure continued proficiency.

g. Qualification Requirements

The YAEC Construction Quality Assurance Manager was responsible for assuring effective implementation of the Project QA program and the contractor programs. The qualification requirements for this position were described in Subsection 17.1.1.

h. Controlled Conditions

It is a requirement that all quality-related activities, such as inspection and test, were performed with appropriate equipment and under suitable environmental conditions and in compliance with necessary prerequisites for the given activity.

i. Management Review

YAEC QAD, on a scheduled basis, conducted audits of the YAEC, UE&C and WRD QA program activities to ensure that there was proper implementation and that the program was effective. The YAEC procedures for implementation of the program were contained in the Seabrook Station Quality Assurance Manual.

At least annually, NHY management performed, or has performed, an audit of the activities of YAEC Construction Quality Assurance activities.

SEABROOK STATION UFSAR	<p style="text-align: center;">QUALITY ASSURANCE</p> <p style="text-align: center;">Quality Assurance During Design and Construction</p>	<p style="text-align: center;">Revision 8 Section 17.1 Page 13</p>
---------------------------------------	--	--

j. Advance Planning

Planning for the control of management and technical interfaces between the UE&C, WRD, YAEC and NHY during all phases, including the phaseout of design, construction and preoperational testing phases and plant turnover was developed by the Director of Engineering and Licensing. The details of the program were completed prior to the performance of the activities.

k. Program Update

The Seabrook Station Quality Assurance Program was reviewed by YAEC QAD at least annually to ensure that it was kept current. YAEC performs audits on WRD and UE&C to ensure that their programs were kept up-to-date and effective.

The YAEC program for quality assurance normally involves three control levels:

Level 1 - Quality control by vendors, constructors and UE&C on the activities they perform, by YAEC on startup activities. This includes reviews, inspections and tests.

Level 2 - Surveillance of design, fabrication and construction activities, including Level 1 Quality Control. Contractors provided this level for the design and procurement phases. UE&C and YNSD provided additional surveillance on site construction activities.

Level 3 - Audits by YAEC QA Department of activities performed by Level 1 and 2 organizations.

YAEC provided the third level for all activities. At each level, the individual or group responsible for reviewing, inspecting, auditing or otherwise verifying that an activity has been correctly performed was independent of the individual or group responsible for performing the specific activity. The degree of control at each level reflected the importance of the activity to plant safety and reliability.

17.1.1.3 Design Control

WRD, as the nuclear steam system supplier, established a program for design control which is described in WCAP-8370. The program required WNES review of design specifications, appropriate drawings, calculations, procedures and instructions generated within the various Westinghouse organizations and by their suppliers.

SEABROOK STATION UFSAR	<p style="text-align: center;">QUALITY ASSURANCE</p> <p style="text-align: center;">Quality Assurance During Design and Construction</p>	Revision 8 Section 17.1 Page 14
---------------------------------------	--	---------------------------------------

UE&C, responsible for the balance-of-plant equipment up to the time of final acceptance by NHY, provided design control measures on other organizations within the scope of its responsibilities. Subsequent to final acceptance, design changes are controlled by the NHY Nuclear Production Operational Quality Assurance Program.

The UE&C program for design control is explained in UEC-TR-001.

The design control programs comply with the requirements of 10 CFR 50, Appendix B; with applicable codes, standards, and regulatory guides; and with ANSI 45.2.11 "Quality Assurance Requirements for Design of Nuclear Power Plants." The design control programs respond to the attributes indicated in Subsections 17.1.1.3a through 17.1.1.3f of this Updated FSAR.

a. Design Requirements

There were written procedures for the performance of design activities in a planned, controlled and orderly manner. These, as well as the auditing systems applied to verify compliance, provided assurance that applicable regulatory requirements and design bases were correctly translated into specifications, drawings, written procedures and instructions.

Design documents specified appropriate quality standards and provide methods for controlling deviations and changes of the standards. Errors and deficiencies that adversely affected safety-related structures, systems and components in the design process were documented and appropriate corrective action was taken.

b. Material Selection

Standard "off-the-shelf" commercial or previously approved materials, parts, and equipment that were essential to the safety-related functions of structures, systems, and components were reviewed for suitability of application prior to selection. Standard "off-the-shelf" commercial or previously approved items received adequate application, review and selection.

c. Analyses, Compatibility and Accessibility

Design considerations such as stress, thermal, hydraulic, radiation and accident analyses, reactor physics, compatibility of materials, inspection and test criteria, and accessibility for in-service inspection, maintenance and repair were adequate and suitably controlled. Designs were reviewed to ensure that design characteristics could be controlled, inspected and tested and to ensure that inspection and test criteria were identified.

SEABROOK STATION UFSAR	<p style="text-align: center;">QUALITY ASSURANCE</p> <p style="text-align: center;">Quality Assurance During Design and Construction</p>	Revision 8 Section 17.1 Page 15
---------------------------------------	--	---------------------------------------

d. Verification

Design verification or checking, such as design reviews, alternate calculations and qualification testing, were properly selected and performed. When a test program was used to verify the adequacy of a design, a qualification test of a prototype unit was performed under the most adverse design conditions. The individuals or groups who performed design verification or checking were other than those who performed the original design. These individuals or groups and their authority and responsibility were identified and controlled by written procedures. Compliance to Regulatory Guide 1.64, Revision 2, and ANSI N45.2.11 was ensured through the review of contractors QA manuals or procedures regarding Design Control. Implementation was verified via audits which sampled objective evidence of the design verification process. Selective review of contractor design documents by YAEC personnel was also performed and the verification and approval activity performed by the contractors was an element considered during this YAEC review and comment cycle. WRD and UE&C had the responsibility for assuring that proper design reviews or verifications were accomplished.

e. Interface Controls

Design interface controls of both external and internal participating organizations were procedurally described and controlled. Design documents, and revisions thereto, were distributed to the responsible persons in a timely and orderly manner and controlled to prevent inadvertent use of superseded documents. Design documents, design reviews, records, and changes thereto, were collected, stored and maintained in a systematic and controlled manner.

Interface material, including drawings, were provided to the Engineer-Constructor, UE&C, in the Westinghouse Project Information Package (PIP). The drawings included in the PIP provided information, such as location and safety class, which was used by UE&C in preparing balance-of-plant and nuclear system flow diagrams. The PIP also provided specific information on component design required by UE&C for their detailed design.

The UE&C drawing index lists all UE&C-originated drawings. Westinghouse reviewed this listing and selected those drawings which they required for information and their design purposes. As these drawings were issued and revised, they were sent to Westinghouse for their use. UE&C retains the responsibility for interface control.

SEABROOK STATION UFSAR	<p style="text-align: center;">QUALITY ASSURANCE</p> <p style="text-align: center;">Quality Assurance During Design and Construction</p>	Revision 8 Section 17.1 Page 16
---------------------------------------	--	---------------------------------------

f. Design Changes

Design, drawing, and specification changes, including field changes, were subject to the same design controls that apply to the original design and were reviewed and approved by the organization that performed the original design unless the originating organization designated another responsible organization.

g. Document Approval

Procedures contained in the Seabrook Station Quality Assurance Manual detail the process for completing the YAEC internal and inter-organizational review and approval cycle. The specifications for items listed in Table 17.1-1, Table 17.1-2 and Table 17.1-3 were reviewed by YAEC. As mutually agreed upon by the YAEC Project Manager, Engineering and QAD reviews of selected specifications were documented. Coordinated by the Project Manager, the design documents were distributed to the YAEC Engineering and Quality Assurance Departments for performance of the applicable reviews. The procedures defined the review requirements. Reviewer's comments were resolved with all affected organizations, and the Project Manager formalized the approval and/or release of documents.

h. Audits

YAEC QAD performed audits of YAEC departments, WRD, UE&C, and selected suppliers to verify that the design control programs for safety-related equipment were implemented effectively. These audits were conducted in accordance with the Seabrook Station Quality Assurance Manual.

17.1.1.4 Procurement Document Control

a. Specifying Requirements

The Seabrook Station Quality Assurance Program provides for the control of procurement documents for safety-related equipment consistent with the guidelines of 10 CFR 50, Appendix B applicable codes, standards, regulatory guides, and ANSI 45.2.13 "Quality Assurance Requirements for Control of Procurement of Items and Services for Nuclear Power Plants."

WRD, responsible for supplying the Nuclear Steam Supply System, described its program for the control of procurement documents in WCAP-8370. UE&C, responsible for supplying the balance-of-plant construction has described its program for control of procurement documents in Subsection 17.1.2.

SEABROOK STATION UFSAR	<p style="text-align: center;">QUALITY ASSURANCE</p> <p style="text-align: center;">Quality Assurance During Design and Construction</p>	Revision 8 Section 17.1 Page 17
---------------------------------------	--	---------------------------------------

All purchase specifications, and changes thereto, contained or referenced as applicable: design information and technical requirements including codes, standards, regulatory requirements, components and material identification; drawings, specifications, including their applicable revision; tests and inspection requirements; and special process instruction for such activities as fabrication, cleaning, erecting, packaging, handling, shipping, storing, and inspecting. The specifications contained requirements which identified the documents to be prepared, maintained, submitted, and made available to the buying agent for review and/or approval. The specifications contain, as appropriate, the requirement for reporting and disposition of nonconformances from procurement requirements. These documents included, as applicable, drawings, specifications, procedures, inspection and fabrication plans, inspection and test records, personnel and procedure qualifications, and materials, chemical and physical test results. The specifications also contained applicable requirements for the retention, control and maintenance of records, and the procuring agency's right of access to the vendor's facilities and records for source inspection and audit. Contract Procurement Documents specified the records that were to be delivered to the purchaser prior to use or installation of the hardware. Compliance to ANSI N45.2.9, N45.2.13 and ASME Section III was ensured via review of Contractor (UE&C & W) procedures, specifications and records requirements specified in procurement documentation. Verification was performed via a system of audits and/or surveillance performed by YAEC Home Office and/or Site QA personnel. The specifications contained provisions for extending applicable requirements of the document to subcontractors and suppliers, including purchaser's right of access to such subvendors' facilities and records.

Prior to their release to suppliers, procurement documents for safety-related items, equipment and services were subject to review by the originating organization. The review, conducted by qualified personnel, determined that quality requirements were correctly stated, inspectable, and controllable, that there were adequate acceptance and rejection criteria, and that the procurement document had been prepared and approved in accordance with program requirements. Prior to the issuance of purchase orders, WRD and UE&C submitted lists of potential suppliers (bidders list) to YAEC for technical review and approval. Subsequent to obtaining YAEC approval of the potential supplier list, WRD issued purchase orders to those suppliers listed. UE&C submitted bid packages (including a recommended supplier) to NHY for approval prior to releasing purchase documents.

YAEC was responsible for surveillance and audit of WRD and UE&C programs to ensure that the procurement control of safety-related materials, services and

SEABROOK STATION UFSAR	<p style="text-align: center;">QUALITY ASSURANCE</p> <p style="text-align: center;">Quality Assurance During Design and Construction</p>	<p style="text-align: center;">Revision 8 Section 17.1 Page 18</p>
---------------------------------------	--	--

equipment, including spare or replacement parts, met the requirements of 10 CFR 50, Appendix B, and applicable codes, standards, regulatory guides and quality assurance provisions. YAEC also reviewed and approved WRD and UE&C specifications for compliance with these requirements.

The YAEC Quality Assurance Department reviewed and audited the WRD and UE&C quality program prior to the placement of any procurement documents for safety-related equipment. In addition, YAEC audited the activities of contractors utilized for such services as meteorology, seismicity, and soils analysis as required during the Project.

Procurement of spare parts and test equipment originated by the NHY station staff was controlled by the NHY Nuclear Production Operational Quality Assurance Program.

b. Review and Approval

WCAP-8370 and Subsection 17.1.2 describe the measures that clearly delineate the control responsibilities and action sequence taken in the preparation, review, approval and issuance by competent personnel of procurement documents and the measures that ensured that changes or revisions of procurement documents were subject to the same review and approval requirements as the original documents.

c. Survey of Suppliers

WCAP-8370 and Subsection 17.1.2 describe the measures that ensured that procurement documents required suppliers to have and implement a documented QA program for purchased materials, equipment and services to an extent consistent with their importance to safety; that the purchaser evaluated the supplier before the award of the procurement order or contract to ensure that the supplier could meet the procurement requirements, and that procurement documents for spare or replacement items would be subject to controls at least equivalent to those used for the original equipment.

d. Audits

The YAEC Quality Assurance Department performed audits to ensure compliance with program requirements by YAEC, NHY, WRD, UE&C selected suppliers, and site constructors.

SEABROOK STATION UFSAR	<p style="text-align: center;">QUALITY ASSURANCE</p> <p style="text-align: center;">Quality Assurance During Design and Construction</p>	<p style="text-align: center;">Revision 8 Section 17.1 Page 19</p>
---------------------------------------	--	--

17.1.1.5 Instructions, Procedures and Drawings

a. Quality Control Instructions

The Seabrook Station Quality Assurance Program included a system for controlling all documents, procedures, instructions, or drawings that were required for quality-related activities associated with the design, procurement, testing, inspecting, construction, preoperational testing and auditing of all safety-related material, structures, systems and components.

WRD and UE&C, as major suppliers, were responsible for establishing systems for controlling instructions, procedures, and drawings within their own organizations and those of their suppliers. The WRD program is described in WCAP-8370 and the UE&C program is described in UFC-TR-001. The control of instructions, procedures, and drawings, with YAEC, is described in the Seabrook Station Quality Assurance Manual. Those instructions, procedures and drawings prepared by the Startup Test Group were handled in accordance with written, approved procedures.

b. Acceptance Criteria

Activities affecting quality were defined in instructions, procedures, and drawings and included appropriate qualitative and quantitative acceptance criteria to ensure that specific activities were satisfactorily accomplished. References to these documents, when pertinent, identified the applicable revision. Instructions, procedures and drawings were reviewed and approved by appropriate supervisors or management. YAEC reviewed contractor quality assurance manuals to ensure incorporation of program requirements.

c. Audit and Surveillance

YAEC was responsible for auditing and surveillance of the WRD, UE&C, selected suppliers and site constructor programs to ensure that the instructions, procedures, and drawings used on safety-related equipment were controlled and met the requirements of 10 CFR 50, Appendix B.

17.1.1.6 Document Control

a. Issuance

The Seabrook Station Quality Assurance Program provided for the control of all documents affecting the quality of safety-related structures, systems and

SEABROOK STATION UFSAR	QUALITY ASSURANCE Quality Assurance During Design and Construction	Revision 8 Section 17.1 Page 20
---------------------------------------	---	---------------------------------------

equipment during the design, procurement, construction and preoperational phases of the project.

The program established controls to ensure that obsolete or superseded documents were not inadvertently used, that the individuals or groups responsible for reviewing, approving, and issuing documents were identified, that changes to documents were reviewed and approved by the same organizations that performed the original review, that approved changes were promptly distributed, and that the applicable documents were available prior to the start of work at the location where the activity was performed.

WRD and UE&C were responsible for assuring document control within their internal organizations and their suppliers. The WRD program for document control was described in WCAP-8370 and the UE&C measures described in UEC-TR-001. The contractors were required to perform surveillance audits and inspections to ensure that their programs were properly implemented. Periodically, WRD and UE&C forwarded to YAEC an updated index listing the applicable specifications and drawings. The YAEC Project Manager periodically reviewed his files to ensure that superseded documents were destroyed or identified as being obsolete.

b. Identification

The program required that procedures and instructions were prepared to control the preparation, review, approval, revision or change, issuance and distribution of at least the following:

	<u>Document</u>	<u>Responsible Organization(s)</u>
1.	Design specifications and drawings	WRD-UE&C
2.	Manufacturing, construction, and installation drawings	WRD-UE&C
3.	Procurement documents	WRD-UE&C-YAEC
4.	Quality Assurance Manuals, procedures, and instructions	WRD-UE&C-YAEC
5.	Manufacturing and construction inspection, test and special process instructions and procedures	WRD-UE&C-YAEC

SEABROOK STATION UFSAR	<p style="text-align: center;">QUALITY ASSURANCE</p> <p style="text-align: center;">Quality Assurance During Design and Construction</p>	<p style="text-align: center;">Revision 8 Section 17.1 Page 21</p>
---------------------------------------	--	--

Document

Responsible Organization(s)

- 6. FSAR and related design criteria documents

YAEC

c. Audits

YAEC Quality Assurance Department periodically verified, by audits and surveillance, that WRD, UE&C, selected suppliers, site constructors and the YAEC organization complied with these requirements.

17.1.1.7 Control of Purchased Material, Equipment, and Services

a. Selection and Control of Suppliers

The Seabrook Station Quality Assurance Program established controls to ensure that purchased construction material, equipment, and services, whether purchased directly or through contractors and subcontractors, conformed to the procurement document requirements. These measures included provisions for source evaluation and selection of vendors, objective evidence of quality furnished by the contractor or subcontractor, inspection and audit at the supplier source, and examination of products prior to or upon delivery.

Purchasing of safety-related items was the responsibility of WRD and UE&C as applicable. YAEC and Project contractors, WRD and UE&C, established measures for the control of purchased safety-related material, equipment and services applicable to the scope of their contracts. The UE&C measures were contained in Subsection 17.1.2 and the WRD measures were contained in WCAP-8370. These measures include:

- 1. Evaluation of suppliers prior to the award of procurement orders or contracts by qualified personnel using written procedures and check lists. Quality assurance and engineering personnel participated in the evaluation of those suppliers providing critical components.
- 2. The evaluation of suppliers was based on one or more of the following:
 - (a) An audit to verify supplier's capability to comply with the applicable elements of 10 CFR 50, Appendix B, which were applicable to the type of material, equipment, or service being procured.

SEABROOK STATION UFSAR	<p style="text-align: center;">QUALITY ASSURANCE</p> <p style="text-align: center;">Quality Assurance During Design and Construction</p>	<p style="text-align: center;">Revision 8 Section 17.1 Page 22</p>
---------------------------------------	--	--

- (b) A review of previous records and recent performance of suppliers who had provided articles similar to those being procured.
 - (c) A survey of the supplier's facilities and quality assurance program to determine capability to supply a product which met the design, manufacturing and quality requirements.
3. Results of surveys and audits were documented and kept on file.
4. Planning and performance of surveillance of suppliers during fabrication, inspection, testing and shipment of materials, equipment and components were in accordance with written procedures to ensure conformance to the purchase order requirements. These procedures provided for:
- (a) Instructions that specified the characteristics or processes to be witnessed, inspected or verified, and accepted, which described the method of surveillance and the extent of the documentation required, and which specified those responsible for implementing the instructions.
 - (b) Audits or surveillance during design, manufacture, inspection and testing of procured items or services which ensured that the supplier complied with all quality requirements. Surveillance was performed on those items whose verification of procurement requirements cannot be determined upon receipt or during intermittent audits.
5. Performance of receiving inspection of supplier-furnished material, equipment and services was performed in accordance with written procedures which ensured the following:
- (a) The material, component, or equipment was properly identified and corresponded with the receiving documentation.
 - (b) Inspection of the material, component or equipment, and acceptance records was performed and judged acceptable in accordance with predetermined inspection instructions. Items and their records were approved prior to installation or use.
 - (c) Inspection records or certificates of conformance attesting to the acceptance of material, components, and equipment were available at the nuclear power plant prior to installation or use.

SEABROOK STATION UFSAR	<p style="text-align: center;">QUALITY ASSURANCE</p> <p style="text-align: center;">Quality Assurance During Design and Construction</p>	<p style="text-align: center;">Revision 8 Section 17.1 Page 23</p>
---------------------------------------	--	--

- (d) Items accepted and released were identified as to their approved inspection status prior to forwarding them to a controlled storage area or releasing them for installation or further work.
- (e) Nonconforming items were segregated, controlled, and clearly identified until proper disposition was made.

Purchased material, equipment and services originated by the NHY station staff was controlled by the NHY Nuclear Production Operational Quality Assurance Program.

The YAEC Quality Assurance Department evaluates the control measures in the quality assurance programs of WRD and UE&C by reviewing their quality assurance programs and by a system of periodic audits. These evaluations provide assurance that they were capable of providing equipment, material and services which meet the applicable regulatory requirements. The audits were performed to verify that WRD and UE&C comply with the control measure applicable to the material, equipment, and services involved.

WRD and UE&C, based upon the complexity of purchased items and supplier performance history, performs source inspections or audits of vendors as necessary to ensure that the required quality of the items was obtained. Surveillance of supplier's fabrication, testing, inspection and shipment of materials, equipment and components was planned, performed and reported in accordance with written procedures which ensured conformance to the purchase order requirements.

Prior to the solicitation of bids, WRD and UE&C submitted lists of prospective suppliers to YAEC for review and approval and for suggested additions. YAEC recommended addition or removal of suppliers based on prior YAEC experience with the suppliers.

If there were potential suppliers for which WRD or UE&C, as applicable, had no quality history, release of the purchase order was contingent upon successful audit of the suppliers' facilities and implementation of their quality program. The YAEC Quality Assurance Department participated in audits and performed independent audits of selected suppliers and established notification points on selected safety-related equipment for YAEC participation in WRD and UE&C inspection, test or audit operations. Notification points for product surveillance were selected so that a cross section of fabrication, inspection, and testing operations were observed on the various product types (i.e., pumps, valves, tanks, reactor vessels, instrumentation). The purpose of the surveillance was to verify

SEABROOK STATION UFSAR	<p style="text-align: center;">QUALITY ASSURANCE</p> <p style="text-align: center;">Quality Assurance During Design and Construction</p>	<p style="text-align: center;">Revision 8 Section 17.1 Page 24</p>
---------------------------------------	--	--

the adequacy of the WRD and UE&C vendor control. YAEC selected notification points were transmitted by the Project Manager to WRD and UE&C, as applicable.

The review and approval of inspection plans, test, calibration and special process procedures were performed by Contractor (UE&C and WRD) personnel. YAEC reviewed the Contractor's systems of review and approval which included the control of revisions. Adequacy of contractor reviews was substantiated via YAEC audit and/or surveillance at constructor and/or supplier facilities. YAEC QA personnel review contractor (UE&C & WRD) specifications and applicable drawings to ensure that they adequately specified the requirements regarding inspection plans, tests, calibration and special process procedures. The YAEC review was performed in accordance with approved procedures.

Documentation required by the procurement document specification was reviewed by the appropriate contractor quality assurance group prior to release of the hardware for shipment. The specifications identified specific requirements such as codes, regulatory guides, standards, and specifications. It was the responsibility of the contractors, WRD and UE&C, to periodically verify suppliers' certificates of conformance to ensure that they were meaningful.

Upon receipt of items, material, or equipment at the site, UE&C performed receiving inspection. Receiving inspection verified that all required documentation was received, that the item, material or equipment conformed to the purchase order requirements, that the documentation was traceable to the item, material or equipment, and that the item, material or equipment was inspected for shipping damage. Certification was furnished by the supplier which identified any procurement requirements which have not been met together with a description of the disposition of each nonconformance. Appropriate records were maintained to indicate completion of these activities. Material, equipment or items lacking the required documentation were identified as nonconforming and placed in a "hold" status pending receipt of the necessary documentation.

b. Audits

The YAEC Quality Assurance Department audits WRD, UE&C and selected suppliers, and participated during WRD and UE&C audits of selected suppliers to assess the adequacy of supplier control measures for purchased material, equipment and services and of the WRD and UE&C audit systems. These YAEC audits, performed in accordance with requirements contained in the Seabrook

SEABROOK STATION UFSAR	<p style="text-align: center;">QUALITY ASSURANCE</p> <p style="text-align: center;">Quality Assurance During Design and Construction</p>	<p style="text-align: center;">Revision 8 Section 17.1 Page 25</p>
---------------------------------------	--	--

Station Quality Assurance Manual, occurred at intervals consistent with the importance, complexity and quality of the item or service.

17.1.1.8 Identification and Control of Material, Parts and Components

The Seabrook Station Quality Assurance Program required that all organizations performing safety-related activities establish procedures to provide identification and control of materials, parts, and components, including partially fabricated assemblies, to prevent the use of incorrect or defective material, parts, and components and that measures ensured that identification of the item was maintained by a unique number either on the item or on records traceable to the item throughout fabrication, erection, installation, and use of the item. The location and method of identification did not affect the function or quality of the item being identified. Verification of identification was accomplished at appropriate stages throughout manufacturing, shipping, receipt, and installation.

WRD and UE&C developed methods for identification and control of materials, parts and components within the scope of their responsibilities. The UE&C program was detailed in UEC-TR-001 and the WRD program was detailed in WCAP-8370.

During the design stages, WRD and UE&C developed systems identification and assigned unique identification numbers, as appropriate, to items in a system. These numbers provide traceability of all associated documentation such as manufacturing and inspection documents, deviation reports, and material test reports.

WRD and UE&C were responsible for imposing their identification and material control system requirements on their suppliers and ensured implementation through inspections, surveillance, and audits. UE&C ensured that the required identification and traceability of all safety-related materials, parts, and components were maintained from receipt at the site through the completion of construction.

YAEC provided assurance of the implementation of these requirements by means of audits and surveillance of WRD, UE&C, selected suppliers and site constructors.

17.1.1.9 Control of Special Processes

The Seabrook Station Quality Assurance Program required that all organizations performing special processes develop a system of special process qualifications and controls. Special processes included, but were not limited to welding, heat treating, nondestructive testing, cleaning and electrochemical machining.

The program required that all organizations performing special processes on safety-related items did so in accordance with approved procedures under controlled conditions. Personnel and the

SEABROOK STATION UFSAR	<p style="text-align: center;">QUALITY ASSURANCE</p> <p style="text-align: center;">Quality Assurance During Design and Construction</p>	<p style="text-align: center;">Revision 8 Section 17.1 Page 26</p>
---------------------------------------	--	--

procedures and equipment used performing special processes were qualified in accordance with applicable codes, standards, specifications, or regulatory guides. The procedure used written check lists or other written instructions as applicable. Equipment used in the performance of special processes was calibrated as detailed in Subsection 17.1.1.12. Qualification records of procedures, equipment and personnel associated with special processes were maintained, filed, and kept current.

WRD and UE&C were responsible for imposing these requirements on their own organizations and on their suppliers and subcontractors performing work within the scope of this program. Procedures of their suppliers and subcontractors were submitted for review and approval as required in the applicable procurement documents. WRD and UE&C ensured implementation of these requirements through a system of audits and surveillances.

The UE&C program for control of special processes was described in UEC-TR-001 and the WRD program was described in WCAP-8370. Special processes performed by the NHY Station Staff were controlled by the NHY Nuclear Production Operational Quality Assurance Program.

YAEC ensured conformance to these requirements by WRD, UE&C, and their suppliers and site constructors through a program of audits and surveillance.

17.1.1.10 Inspection

All organizations responsible for inspection of safety-related equipment and systems were required to have a documented program which includes the use of qualified inspection personnel and written inspection instructions.

The WRD inspection program for the manufacture of the NSSS equipment was detailed in WCAP-8370. The UE&C program for inspection of safety-related items for the balance of plant and for site activities was detailed in UEC-TR-001.

a. Inspection Program Implementation

The programs required that design specifications, drawings, purchase orders, procedures or instructions included the necessary inspection requirements with acceptance and rejection criteria. These inspection requirements were translated into inspection programs, procedures, and check lists, by manufacturing, construction, installation and test activities in order to specify, control and provide documented evidence of inspection activities. Inspection procedures, instruction and check lists contained the following:

1. Identification of characteristics to be inspected

SEABROOK STATION UFSAR	<p style="text-align: center;">QUALITY ASSURANCE</p> <p style="text-align: center;">Quality Assurance During Design and Construction</p>	<p style="text-align: center;">Revision 8 Section 17.1 Page 27</p>
---------------------------------------	--	--

2. Identification of individuals or groups responsible for performing the inspection operation
3. Acceptance and rejection criteria
4. Definition of the inspection method
5. Verification of inspection completion and certification
6. A record of the results of the inspection operation.

Inspections were performed for each work operation as necessary to verify quality.

Qualified inspectors, independent from the individual or group performing the activity being inspected, performed inspections using equipment that had been calibrated in accordance with the requirements of Subsection 17.1.1.12. Inspectors were qualified in accordance with appropriate codes, standards, and regulatory guides and their qualifications and certifications were kept current and on file. Inspection procedures, plans, instructions or check lists were maintained where the activity was to be performed prior to the start of work. Rework, repair, or modifications were inspected in accordance with the original design and inspection requirements or acceptable alternatives. Where direct inspection was not possible, provisions were established for indirect control by monitoring process methods, equipment and personnel. Both inspection and process monitoring were used when control was inadequate without both. Inspection results were evaluated to determine that the requirements have been satisfied. Personnel performing receiving inspection, tests and verification processes were required to be qualified to the requirements of Regulatory Guide 1.58, ANSI N45.2.6 and N45.2. YAEC QA personnel reviewed the Constructors QA Manuals, Procedures and Procurement Documents to ensure that the required commitments were imposed upon all site personnel and organizations. YAEC QA personnel performed surveillance and audit activity over the constructor and construction subcontractors.

b. Inspection Holdpoints

When UE&C, WRD or YAEC notification or hold points were established by the procurement document, or internally by the fabricator, the inspection program or plan provided that work did not progress beyond the inspection point until released by the designated authority.

SEABROOK STATION UFSAR	<p style="text-align: center;">QUALITY ASSURANCE</p> <p style="text-align: center;">Quality Assurance During Design and Construction</p>	Revision 8 Section 17.1 Page 28
---------------------------------------	--	---------------------------------------

UE&C performed receiving, construction and installation process verification inspections at the construction site.

c. Requirements for Suppliers

WRD and UE&C were responsible for imposing these requirements on their internal operations and those of their vendors and subcontractors. They performed audits or surveillance to ensure the adequacy of the implementation of these requirements. In general, inspections were the responsibility of the manufacturing or construction organizations, with WRD, UE&C and YAEC performing the audits or surveillance.

d. Audits

YAEC performed audits of WRD and UE&C and participated in inspections at selected vendor facilities to verify implementation with specifications, applicable codes, standards, and regulatory guides. YAEC also performed surveillance of site constructor activities in accordance with this program.

17.1.1.11 Test Control

a. Test Control Implementation

YAEC assigned to WRD and UE&C the control of testing of safety-related materials, equipment, and structures during all phases of manufacturing, construction and installation.

The UE&C test program for material, equipment, and structures within the balance of plant and for site activities was detailed in UEC-TR-001. The WRD test program for the nuclear steam supply system components was detailed in WCAP-8370.

Supplier and subcontractor test procedures were subject to review and approval by the contractor having responsibility for the item.

The WRD and UE&C programs required that all testing necessary to demonstrate that materials, equipment, and structures perform satisfactorily in service was identified, accomplished, and documented in accordance with written controlled procedures. These procedures are based on the requirements of the codes and standards referenced in Table 3.2-3. These written procedures include requirements for the following:

SEABROOK STATION UFSAR	<p style="text-align: center;">QUALITY ASSURANCE</p> <p style="text-align: center;">Quality Assurance During Design and Construction</p>	<p style="text-align: center;">Revision 8 Section 17.1 Page 29</p>
---------------------------------------	--	--

1. Instructions for testing method and test equipment and instrumentation
2. Calibrated instrumentation
3. Adequate and appropriate equipment
4. Trained, qualified, and licensed or certified personnel
5. Preparation, condition, and completeness of the item to be tested
6. Suitable and controlled environmental conditions
7. Mandatory inspection hold points for witness by YAEC, WRD, UE&C, and authorized inspector
8. Provisions for data collection and storage
9. Acceptance and rejection criteria
10. Methods for documenting or recording test data and results.

The control of testing during the initial test program was discussed in Chapter 14.

b. Test Procedure

Test results were documented and evaluated to the established criteria by a qualified, responsible individual or group.

c. Test Results

See Subsection 17.1.1.11b.

d. Requirements on Others

WRD and UE&C were responsible for imposing these requirements on their internal organization and on their vendors and subcontractors. Through auditing and surveillance, they ensured the adequacy of the program implementation.

e. Audits

YAEC, through a program of planned audits of WRD, UE&C, selected audits of their vendors and subcontractors, and surveillance of site constructor activities ensured their conformance to the program requirements.

SEABROOK STATION UFSAR	<p style="text-align: center;">QUALITY ASSURANCE</p> <p style="text-align: center;">Quality Assurance During Design and Construction</p>	Revision 8 Section 17.1 Page 30
---------------------------------------	--	---------------------------------------

17.1.1.12 Control of Measuring and Test Equipment

During manufacturing, responsibility for the control of measuring and test equipment for all phases of measurement, inspection and monitoring of safety-related materials, components, and structures was delegated to WRD and UE&C. UE&C was also responsible for specifying the requirements for the control of measuring and test equipment at the construction site.

The WRD program for control of measuring and test equipment was detailed in WCAP-8370 and the UE&C program was detailed in UEC-TR-001.

These programs required that all organizations performing measuring or testing operations on safety-related materials, components, systems and structures had written procedures describing the calibration technique and frequency, maintenance, and control of all measuring and test instruments, tools, gages, fixtures, reference and transfer standards, and nondestructive test equipment which were used. Reference and transfer standards were required to have traceability to nationally recognized standards, or, where national standards did not exist, provisions were established to document the basis for calibration.

All measuring and test equipment was identified and the calibration test data was identified for the equipment to which it applied. The contractors (UE&C and WRD) were required to conform to a calibration requirement of marking, labeling or tagging of measuring and test equipment indicating date of next calibration. UE&C and WRD were committed to this requirement in their Topical Reports UEC-TR-001 and WCAP-8370. Suppliers and subcontractors were required to a similar provision in their QA programs which were approved by the Contractors and Constructor. The calibration frequency depended upon the required accuracy, purpose, degree of usage, stability characteristics and the manufacturers' recommendation. Records of the status of all items under the calibration system were maintained as required by ANSI N45.2.9.

UE&C, who was responsible for the procurement of equipment for the balance-of-plant, required in their quality assurance program that suppliers maintain a system which ensured that calibrating standards have an uncertainty (error) requirement of no more than 1/4 of the tolerance of electrical equipment being calibrated and 1/10 of the tolerance for all other equipment being calibrated, except where limited by the state-of-the-art.

Westinghouse, who was responsible for procurement of the NSSS equipment, required that when calibrating measuring and test equipment, typical transfer ratios of 10-1 were used for mechanical equipment; 4-1 for electrical equipment; and 4 or 5-1 for precision mechanical measuring equipment.

An investigation was conducted to determine the validity of previous inspections performed when measuring and test equipment was found to be out of calibration. The results of this

SEABROOK STATION UFSAR	<p style="text-align: center;">QUALITY ASSURANCE</p> <p style="text-align: center;">Quality Assurance During Design and Construction</p>	Revision 8 Section 17.1 Page 31
---------------------------------------	--	---------------------------------------

investigation were documented. Inspections were repeated, as necessary, using calibrated equipment to establish acceptability of suspect items.

WRD and UE&C were responsible for imposing these requirements on their internal operations and on their vendors and constructors. WRD and UE&C performed audits and surveillance to ensure the adequacy of the program.

YAEC performed audits of WRD, UE&C, selected vendors, and site constructors, to ensure conformance with the program requirements.

17.1.1.13 Handling, Storage and Shipping

WRD and UE&C were delegated the responsibility for the handling, storage, and shipping activities performed on all safety-related materials, components, systems, and structures throughout all stages of manufacturing, packing, storage, preservation, cleaning and installation.

The WRD program for the control in these areas was contained in WCAP-8370 and the UE&C program was contained in UEC-TR-001.

The programs required that all handling, storage, shipping, cleaning, preservation of safety-related materials, components, systems and structures be performed by qualified individuals in accordance with prescribed work instructions or procedures to prevent damage or deterioration. These procedures were based on the requirements of applicable codes, standards, regulatory guides and design specifications.

The instructions included inspection operations to verify compliance. Procedures included requirements for special environmental conditions such as inert gas atmosphere, specific moisture content levels, and temperature levels.

WRD and UE&C were responsible for imposing these requirements on their internal operations and on their vendors and constructors. To ensure implementation, they performed audits and surveillance on affected organizations.

YAEC performed audits of WRD, UE&C, and selected suppliers and on site constructors to ensure conformance to the program requirements.

Measuring and test equipment utilized by the NHY Station Staff was controlled by the NHY Nuclear Production Operational Quality Assurance Program.

SEABROOK STATION UFSAR	<p style="text-align: center;">QUALITY ASSURANCE</p> <p style="text-align: center;">Quality Assurance During Design and Construction</p>	<p style="text-align: center;">Revision 8 Section 17.1 Page 32</p>
---------------------------------------	--	--

17.1.1.14 Inspection, Test and Operating Status

WRD and UE&C were delegated the responsibility for indicating the inspection, test and operating status of safety-related material, equipment and components during manufacture. In addition, UE&C was responsible for establishing a requirement that constructors indicate inspection, test and operating status during installation at the construction site. The Startup Test Group was responsible for equipment and system status identification during the Initial Test Program.

The WRD program for indicating the inspection, test and operating status was detailed in WCAP-8370 and the UE&C program was detailed in UEC-TR-001.

Each organization supplying safety-related material, equipment, and structures established a system for identification of the inspection, test and operating status during all phases of their operation. The system was implemented by procedures which describe the use of status indicators such as labels, tags, stamps or routing cards that identify the status of the equipment at any given time.

The program ensured that operations performed out of sequence were controlled through documented measures under the cognizance of the applicable QA organization. Only authorized personnel were permitted to apply or remove tags, markings, or stamps used to indicate inspection, test, or operating status. Stamps used by personnel for completing items such as welds, inspections, and test were controlled and traceable to the user.

The operating status of nonconforming, inoperative, or malfunctioning structures, systems, or components was identified to prevent their inadvertent use in accordance with Subsection 17.1.1.15.

WRD and UE&C were responsible for imposing these requirements on their respective operations and on their vendors.

YAEC, through a system of audits at WRD, UE&C, selected vendors, and site constructors ensured timely implementation of these requirements.

17.1.1.15 Nonconforming Materials, Parts and Components

WRD and UE&C were delegated the responsibility for specifying requirements for the control of nonconforming materials, parts and components during the design, procurement, and construction phases of the project.

The WRD program for the handling, disposition and control of nonconforming items is detailed in WCAP-8370 and the UE&C program is detailed in UEC-TR-001.

SEABROOK STATION UFSAR	<p style="text-align: center;">QUALITY ASSURANCE</p> <p style="text-align: center;">Quality Assurance During Design and Construction</p>	<p style="text-align: center;">Revision 8 Section 17.1 Page 33</p>
---------------------------------------	--	--

The programs established requirements for the following measures by WRD, UE&C, vendors, and constructors:

- a. Procedures to control the identification, documentation, segregation, review, disposition and notification to affected organizations of nonconforming materials, parts, components, or services.
- b. Documentation which identified the nonconforming item described the nonconformance, the disposition of the nonconformance, and the inspection requirements, and included signature approval of the disposition.
- c. Identification of individuals or groups delegated the responsibility and authority to approve the dispositioning of nonconforming items.
- d. Nonconforming items were segregated, size permitting, from acceptable items until properly dispositioned.
- e. Acceptability of rework or repair of material, parts, components, systems, and structures was verified by reinspecting the item as originally inspected or by a method which was at least equal to the original inspection method. Inspection, rework, and repair procedures were documented.
- f. Nonconformance reports dispositioned "Accept As Is" or "Repair" were made part of the inspection records and forwarded with the material to the site.
- g. Nonconformance reports were periodically analyzed by WRD and UE&C to show quality trends, and the results were forwarded to their management. YAEC performed audits to ensure that action was taken.

All safety-related items received at the site which did not conform to the procurement document requirements were identified by UE&C as discrepant and placed in a "hold" status pending disposition. The YAEC Site Quality Assurance representative received a copy of the UE&C report. Discrepant items were segregated, size permitting, pending proper disposition.

UE&C reviewed and approved contractor procedures which ensured the proper reporting, segregation, control and disposition of discrepant items by contractors at the site.

A review of an item of nonconformance which affected site installation or use was made by the organization that established the original design basis for the affected item or an equivalent organization chosen by the management of the original design organization. Recommendations for disposition of the nonconforming items were documented and supporting analyses or calculations were recorded. Nonconformance reports with item dispositions specified "accept as

SEABROOK STATION UFSAR	<p style="text-align: center;">QUALITY ASSURANCE</p> <p style="text-align: center;">Quality Assurance During Design and Construction</p>	Revision 8 Section 17.1 Page 34
---------------------------------------	--	---------------------------------------

is" or "repair" were incorporated as part of the inspection records and forwarded to YAEC for their quality assurance records file. These records were part of the documentation required at the site to permit the installation or use of the item and were accompanied by a certificate of conformance.

When a review by WRD or UE&C indicated that a nonconformance was reportable as defined in Paragraph 50.55(e) of Part 50, Title 10, of the Code of Federal Regulations, WRD or UE&C, as applicable, submitted a report of the nonconformance to the YAEC Project Manager clearly identifying the nonconformance as a possible reportable deficiency. Following disposition of the nonconformance report (reportable as defined in 10 CFR 50, 50.55(e)), but prior to any repair or rework, WRD or UE&C, as applicable, submitted a copy of the report to YAEC with the recommendation that the occurrence be reported. Sufficient justification and data of the proposed action was included to allow preparation of the report required for the regulatory authorities. Repair or rework required YAEC approval.

Nonconformance reports were reviewed by YAEC, WRD and UE&C to ascertain quality trends, and the results were documented and reported to the appropriate management.

WRD and UE&C performed audits and surveillance within their internal operations and those of their vendors and contractors to ensure compliance with the program requirements.

Items identified as nonconforming during the conduct of plant preoperational and startup tests were identified and documented as described in Chapter 14.

YAEC, through audits of WRD, UE&C, site contractors, and selected vendors, ensured overall conformance to these requirements.

17.1.1.16 Corrective Action

YAEC and their contractors, WRD and UE&C, developed programs for the control and implementation of corrective action for all safety-related activities.

The WRD program for the control and implementation of corrective action was detailed in WCAP-8370 and the UE&C program was detailed in UEC-TR-001. The YAEC program was contained in the Seabrook Station Quality Assurance Manual.

a. Identification and Correction

The Seabrook Station Quality Assurance Program required that conditions adverse to quality such as failures, malfunctions, deficiencies, deviations, defective material and equipment, and nonconformances were promptly identified and corrected.

SEABROOK STATION UFSAR	<p style="text-align: center;">QUALITY ASSURANCE</p> <p style="text-align: center;">Quality Assurance During Design and Construction</p>	Revision 8 Section 17.1 Page 35
---------------------------------------	--	---------------------------------------

b. Corrective Action Program

The corrective action program required that conditions adverse to quality be promptly identified, the cause be determined, corrective action be taken to preclude repetition, and verification be made that these actions have been implemented in accordance with specified requirements. It was required that deficiency reports be systematically analyzed to determine the need for corrective action and that the condition, cause, and corrective action taken be reported to the appropriate level of management. Records were maintained to verify that these corrective action measures have been implemented.

c. Documentation

Identification of the significant condition adverse to quality and the need for corrective action identified during YAEC audits were documented. A report of the adverse condition was reported to the appropriate levels of management, including those of YAEC, WRD and UE&C, as applicable. The circumstances surrounding the adverse condition, the action necessary to correct the condition, and the measures taken to preclude repetition were determined and documented by the organization responsible for implementing the needed corrective action. If the specified corrective action affected design of structures, systems, or equipment, concurrence had to be obtained from the organization that established the original design criteria.

d. Follow-up

Follow-up action was taken by organizations reporting deficiencies to verify that specified corrective action was properly implemented and the results forwarded to appropriate levels of management including WRD and UE&C, as applicable. Completed items were closed out and the documentation maintained.

Conditions adverse to quality, requiring stop work action, were acted upon by the YAEC Construction Quality Assurance Manager or his delegates in accordance with established procedures.

e. Reporting Deficiencies

Significant deficiencies, as defined by 10 CFR 50.55(e), were reported to the NRC Office of Inspection and Enforcement by the YAEC Project Manager in accordance with this regulation.

SEABROOK STATION UFSAR	<p style="text-align: center;">QUALITY ASSURANCE</p> <p style="text-align: center;">Quality Assurance During Design and Construction</p>	<p style="text-align: center;">Revision 8 Section 17.1 Page 36</p>
---------------------------------------	--	--

f. Audits

WRD and UE&C performed audits and surveillance on their own operations and those of their vendors to ensure compliance with these requirements.

YAEC, through a system of planned audits of WRD, UE&C, and selected vendors, and a program of internal audits of YAEC departments ensured their conformance to the program requirements.

17.1.1.17 Quality Assurance Records

WRD and UE&C were responsible for the collection of all quality assurance records generated within the scope of their responsibilities and submittal of these records to YAEC prior to fuel loading. The quality assurance records and the required storage and retrieval system were designed to fulfill the requirements of ANSI 45.2.9 "Requirements for Collection, Storage, and Maintenance of Quality Assurance Records for Nuclear Power Plants," with the exception that the records storage facility at the plant site was not tornado proof. The Startup Test Group was responsible for the control of records associated with the initial test program and for the transfer of all relevant data in accordance with Project procedures.

The WRD program providing for collection, storage and maintenance of quality records was described in WCAP-8370 and the UE&C program was described in UEC-TR-001.

a. Objective Evidence

The programs required that records documenting evidence of quality of items and activities include operating logs and the results of reviews, inspections, tests, audits, monitoring of work performance, and material analyses. The records included closely related data such as qualification of personnel, procedures, and equipment. Other documents retained include drawings, specifications, procurement documents, special process and calibration procedures, calibration reports, and nonconforming and corrective action reports. Requirements and responsibilities for record transmittals, retention, and maintenance, subsequent to completion of work or prior to release of material or equipment for installation, were indicated in specifications, procedures and quality programs.

b. Identification and Retrievability

The program specified that inspection and test records contain at least the following:

1. A description of the type of operation

SEABROOK STATION UFSAR	<p style="text-align: center;">QUALITY ASSURANCE</p> <p style="text-align: center;">Quality Assurance During Design and Construction</p>	Revision 8 Section 17.1 Page 37
---------------------------------------	--	---------------------------------------

2. Evidence of completing and verifying a manufacturing, inspection, or test operation
3. The date and results of the inspection or test
4. Information relating to nonconformances
5. Inspector or data recorder identification
6. A statement as to the acceptability of the results.

The program additionally requires that quality records of safety-related items and activities shall be identified, reviewed, retained and retrievable.

c. Storage

The YAEC program included provisions for the identification of records to be kept, the location where they will be maintained and indexes for assuring their retrieval which also indicated retention times required. YAEC arranged for the records storage facility at the site and made provisions for storage of those safety-related records which were not, by prior arrangement, to be retained by WRD, UE&C, or selected suppliers.

The records storage facilities were required to be constructed, located, and secured to prevent destruction of the records by fire, flooding, theft, and deterioration by environmental conditions such as temperature or humidity.

d. Requirements on Others

WRD and UE&C were responsible for imposing applicable requirements on their operations and their vendors. They ensured through audits, surveillance and review of quality-related data, the adequacy of the program implementation. WRD and UE&C were also required to provide quality-related documents which indicated the acceptability of the inspections and other quality functions performed by their quality personnel during surveillance of safety-related equipment.

e. Audits

YAEC, through a program of planned audits of WRD, UE&C, selected vendors, and site constructors ensured overall conformance to the program requirements.

SEABROOK STATION UFSAR	<p style="text-align: center;">QUALITY ASSURANCE</p> <p style="text-align: center;">Quality Assurance During Design and Construction</p>	<p style="text-align: center;">Revision 8</p> <p style="text-align: center;">Section 17.1</p> <p style="text-align: center;">Page 38</p>
---------------------------------------	--	--

17.1.1.18 Audits

WRD and UE&C had a comprehensive system of planned and periodic audits to determine the effectiveness and implementation of their respective programs and those of their vendors. The WRD audit program is described in WCAP-8370 and the UE&C program was described in UEC-TR-001.

The Seabrook Station Quality Assurance Program includes a comprehensive system of planned and periodic audits carried out by the YAEC quality organization as activities were performed to verify compliance with the program requirements. The system provides data for a continuing evaluation of the program effectiveness.

NHY, YAEC, WRD and UE&C established audit programs which comply with 10 CFR 50, Appendix B, and ANSI 45.2.12, "Requirements for Auditing of Quality Assurance Programs for Nuclear Power Plants." The program included the following requirements:

- a. Performance of the following types of audits by NHY, YAEC, WRD and UE&C:
 1. Management audits which provided verification and evaluation of the Quality Assurance Program procedures, and activities to ensure that they effectively complied with corporate policy and with codes, standards and applicable regulatory guides.
 2. Internal audits by the Quality Assurance organization to provide independent verification and evaluation of quality-related procedures and activities to ensure that they effectively complied with the QA program.
 3. External audits performed on suppliers. These audits included verification and evaluation of the supplier's QA program, procedures, and activities to ensure that they effectively complied with all aspects of the QA program and procurement requirements.

- b. Establishment of the requirement that audits were performed in those areas where the requirements of Appendix B to 10 CFR 50 were implemented. These areas included, as a minimum, those activities associated with:
 1. Site-related studies which affected plant safety analyses
 2. The preparation, review, approval, and control of the FSAR, designs, specifications, procurement documents, instructions, procedures, and drawings

SEABROOK STATION UFSAR	<p style="text-align: center;">QUALITY ASSURANCE</p> <p style="text-align: center;">Quality Assurance During Design and Construction</p>	<p style="text-align: center;">Revision 8 Section 17.1 Page 39</p>
---------------------------------------	--	--

3. Requests for proposals and evaluations of bids
 4. Indoctrination and training program
 5. The remaining criteria in Appendix B to 10 CFR 50.
- c. The performance of audits in accordance with pre-established written procedures or check lists by trained personnel not having direct responsibilities in the areas being audited.
 - d. Documentation of audit results and review with management having responsibility in the area audited.
 - e. Responsible management taking the necessary action to correct the deficiencies revealed by the audit.
 - f. Prompt re-audit of deficient areas until corrections have been accomplished.
 - g. An objective evaluation of quality-related practices, procedures, and instructions, the effectiveness of their implementations, and the conformance with policy directives.
 - h. The evaluation of work areas, activities, processes and items, and the review of documents and records.
 - i. The regular scheduling of audits on the basis of the status and safety importance of the activities being performed, initiated early enough to ensure effective quality assurance during the design procurement, manufacturing, construction and installation, inspection, and testing activities.
 - j. The analysis of audit data and the reporting to management of indicated quality trends and the effectiveness of the QA program.

The YAEC audit program, as defined in the Seabrook Station Quality Assurance Manual, included the following types of audits to provide a comprehensive independent verification and evaluation of quality-related procedures and activities to ensure they were in compliance with the established program requirements:

- a. Audits of WRD and UE&C
- b. Audits of selected WRD and UE&C suppliers
- c. Audits at the construction site including initial test program activities

SEABROOK STATION UFSAR	<p style="text-align: center;">QUALITY ASSURANCE</p> <p style="text-align: center;">Quality Assurance During Design and Construction</p>	Revision 8 Section 17.1 Page 40
---------------------------------------	--	---------------------------------------

d. YAEC internal audits.

Audits of WRD and UE&C were conducted as early as possible in the program to ensure compliance with the requirements of codes, standards, applicable regulatory guides and quality assurance provisions. Program areas were subsequently audited consistent with the project schedule or where quality concerns were noted, but, as a minimum, they were audited annually or at least once during the life of the contract, whichever was shorter. The audit frequency may be increased based on experience obtained. Generally, two or three partial audits per year were conducted at both WRD and UE&C to ensure compliance with contract and regulatory requirements and to permit early verification of corrective action.

Independently, or as participants in WRD or UE&C audit teams, YAEC audited selected vendors such as equipment fabricators, material suppliers, consultants and organizations working onsite preparation activities. The audits were based on the safety and code class of the item involved, the complexity of the item, and prior YAEC experience with the supplier. These audits were in addition to those performed by YAEC in conjunction with visits associated with pre-established notification points.

Regularly scheduled audits were supplemented when one or more of the following conditions existed:

- a. When it was necessary to determine the capability of a contractor's quality assurance program prior to award of a purchase order.
- b. When, after award of a purchase order, sufficient time had elapsed for implementing the quality assurance program and it was appropriate to determine that the organization was adequately performing the functions as defined in the quality assurance program description, codes, standards, and other contract documents.
- c. When significant changes were made in functional areas of the quality assurance program such as significant reorganization or procedure revisions.
- d. When it was suspected that the quality of the item was in jeopardy due to nonconformance in the quality assurance program.
- e. When a systematic, independent assessment of program effectiveness was considered necessary.
- f. When it was necessary to verify implementation of required corrective action.

SEABROOK STATION UFSAR	<p style="text-align: center;">QUALITY ASSURANCE</p> <p style="text-align: center;">Quality Assurance During Design and Construction</p>	Revision 8 Section 17.1 Page 41
---------------------------------------	--	---------------------------------------

Surveillance at the construction site was conducted by the YAEC Field QA Surveillance Supervisor and his staff. Personnel from the YAEC headquarter's Quality Assurance staff audited the activities of the YAEC Field QA staff and performed additional audits on contractor activities.

These audits were preplanned and in accordance with written check lists of procedures and were conducted by appropriately trained personnel not having direct responsibility in the areas being audited. The audit schedule was established based on the project status, safety and importance of the activities being performed, and the quality history of the audited activity. Audits were initiated early enough to ensure effective quality assurance for ongoing activities during the initial design and procurement phases.

The program required audit results to be documented, reviewed by or with the management responsible for the area audited, and appropriate action initiated to correct any deficiencies. The organization conducting the audit was responsible for conducting follow-up actions, as necessary, to confirm that corrective action was accomplished as scheduled. Follow-up action was accomplished through written communication, re-audit, or other appropriate means. The audit report distribution included the YAEC and NHY management.

17.1.2 United Engineers & Constructors Inc. Quality Assurance Program

The Quality Assurance program for United Engineers & Constructors Inc., was described in Topical Report No. UEC-TR-001, "Quality Assurance Program" (latest revision), with the exceptions:

- a. The Quality Assurance Program met Regulatory Guide 1.28, Revision 2, requirements including the addition of ANSI N45.2.23.
- b. Field purchases were controlled via UE&C and NHY purchasing procedures.
- c. Duties of Field Superintendent - QA and Supervisor Site QA Engineer were performed by Project Field QC Manager and Project Field QA Manager.

UEC-TR-001 was reviewed by the NRC and evaluated as an acceptable reference for a license application.

17.1.3 Westinghouse Quality Assurance Program

The original Quality Assurance Program implemented by Westinghouse for Seabrook was described in RESAR-3, Amendment 4, as referenced by Updated FSAR Section 17.3. Over the course of performing the design and initial procurement activities for Seabrook, the Westinghouse Quality Assurance Program was upgraded to reflect changes in regulatory

SEABROOK STATION UFSAR	QUALITY ASSURANCE Quality Assurance During Design and Construction	Revision 8 Section 17.1 Page 42
---------------------------------------	---	---------------------------------------

requirements and industry standards. These changes first culminated in Westinghouse topical report, WCAP-8370, Revision 7A (Reference 1) which was applicable to activities from January 1, 1975 to October 1, 1977, as documented in PSAR Amendment 24. This was superseded by Westinghouse topical report, WCAP-8370, Revision 8A (Reference 2) which was applicable to activities from October 1, 1977 to October 31, 1979, and by WCAP-8370, Revision 9A, which was applicable from October 31, 1979 to November 30, 1984.

The Westinghouse Nuclear Fuel Division Quality Assurance Program was described in Westinghouse Topical Report, WCAP-7800, Revision 5 (Reference 4).

The present Westinghouse Water Reactor Divisions Quality Assurance Plan was described in WCAP 8370/7800, Revision 10A/6A (Reference 5) and applies to all Westinghouse Water Reactor Division's (including Nuclear Fuel Division's) activities subsequent to November 30, 1984.

17.1.4 References

1. "Quality Assurance Plan Westinghouse Nuclear Energy Systems Divisions," WCAP-8370, Revision 7A, February 1975.
2. "Westinghouse Water Reactor Divisions Quality Assurance Plan," WCAP-8370, Revision 8A, September 1977.
3. "Westinghouse Water Reactor Divisions Quality Assurance Plan." WCAP-8370, Revision 9A, October 1979.
4. "Nuclear Fuel Division Quality Assurance Program Plan," WCAP-7800, Revision 5, December 1977.
5. "Westinghouse Water Reactor Division Quality Assurance Plan," WCAP-8370/7800, Revision 10A/6A, November 1984.

SEABROOK STATION UFSAR	QUALITY ASSURANCE Quality Assurance During the Operations Phase	Revision 11 Section 17.2 Page 1
---------------------------------------	---	---------------------------------------

17.2 QUALITY ASSURANCE DURING THE OPERATIONS PHASE

The operational Quality Assurance Program is located in the FPL Quality Assurance Topical Report (QATR).

SEABROOK STATION UFSAR	QUALITY ASSURANCE TABLE 17.1-1	Revision: 8 Sheet: 1 of 1
---------------------------------------	-----------------------------------	------------------------------

TABLE 17.1-1 SAFETY-RELATED STRUCTURES

<u>Description</u>	<u>Contractor</u>
Containment Structure	UE&C
Containment Enclosure	UE&C
Primary Auxiliary Building	UE&C
RHR Equipment Vault	UE&C
Fuel Storage Building	UE&C
Waste Processing Building	UE&C
Control and Diesel Generator Building	UE&C
Electrical Cable Tunnels and Penetration Areas (Control Building to Containment)	UE&C
Service Water Pumphouse	UE&C
Emergency Feedwater Pump Building	UE&C
Foundations and Supports for Category I Components	UE&C/WRD
Spent Fuel Pool	UE&C
Cooling Tower	UE&C
Tank Farm	UE&C
Control Room Air Intake Structures	UE&C
Main Steam & Feedwater Pipe Chases	UE&C

SEABROOK STATION UFSAR	QUALITY ASSURANCE TABLE 17.1-2	Revision: 8 Sheet: 1 of 1
---------------------------------------	-----------------------------------	------------------------------

TABLE 17.1-2 SAFETY-RELATED ELECTRICAL SYSTEMS AND INSTRUMENTATION

<u>Description</u>	<u>Contractor</u>
4160 Volt Switchgear (Engineered Safety Features Buses)	UE&C
4160 - 480 Volt Transformer (Associated with Engineered Safety Features)	UE&C
4000 and 460 Volt Motors (Associated with Engineered Safety Features)	UE&C/WRD
4160 Volt Nonsegregated Group Phase Buses (Associated with Engineering Safety Features)	UE&C
480 Volt Load Centers (Associated with Engineered Safety Features)	UE&C
125 Volt DC Batteries (Associated with Engineered Safety Features)	UE&C
Battery Chargers (Associated with Engineered Safety Features)	UE&C
Inverters, 125 Volt DC to 120 Volt AC (Vital Instrument Buses)	UE&C/WRD
Vital Instrument Bus Panels	UE&C
125 Volt DC Power Panels (Associated with Engineered Safety Features)	UE&C
125 Volt DC Switchboards (Associated with Engineered Safety Features)	UE&C
Electrical Tray and Conduit Supports, Fittings and Accessories (Associated with Engineered Safety Features)	UE&C
Containment Penetration Assemblies	UE&C
Power Cables (Associated with Engineered Safety Features System)	UE&C
Instrumentation and Control Cables (Associated with Engineered Safety Feature System)	UE&C
Diesel Generators	UE&C
Diesel Generator Control Panels	UE&C
Reactor Trip System	WRD
Engineered Safety Features Actuation System	WRD
Main Control Board	UE&C

SEABROOK STATION UFSAR	QUALITY ASSURANCE TABLE 17.1-3	Revision: 8 Sheet: 1 of 5
---------------------------------------	-----------------------------------	------------------------------

TABLE 17.1-3 SAFETY-RELATED MECHANICAL EQUIPMENT

	<u>Contractor</u>
<u>Reactor Coolant System</u>	
Reactor	WRD
Full Length Control Rod Drive Mechanism Housing	WRD
Steam Generator	WRD
Pressurizer	WRD
Reactor Coolant Piping, Fittings, and Fabrication	WRD
Surge Pipe, Fittings and Fabrication	WRD
Bypass Manifold	WRD
Reactor Coolant Thermowells	WRD
Safety Valves	WRD
Relief Valves	WRD
Valves to Reactor Coolant System Boundary	WRD/UE&C
Control Rod Drive Mechanism Head Adapter Plugs	WRD
Reactor Coolant Pump	WRD
Internals	WRD
Fuel	WRD
<u>Handling Equipment for Fuel and Reactor Vessel Internals</u>	
Fuel Transfer Tube Outer Sleeve	UE&C
Expansion Joints	UE&C
Reactor Vessel Head Lifting Device	WRD
Fuel Transfer System	WRD
Fuel Transfer Tube and Flange	WRD
Conveyor System and Controls	WRD
Spent Fuel Racks	UE&C

SEABROOK STATION UFSAR	QUALITY ASSURANCE TABLE 17.1-3	Revision: 8 Sheet: 2 of 5
---------------------------------------	-----------------------------------	------------------------------

Contractor

Feedwater System

Emergency Feedwater Pumps	UE&C
Condensate Storage Tank	UE&C
Feedwater Piping (up to and including containment isolation valve)	UE&C

Service Water System

Service Water Pumps	UE&C
Service Water Cooling Tower Pumps	UE&C
Valves and Piping up to and including the isolation valves at the Cooling Water Tunnel	UE&C

Containment Spray System

Spray Additive Tank	UE&C
Containment Spray Pumps	UE&C
Containment Spray Heat Exchangers	UE&C
Valves and Piping	UE&C

Post-Accident Containment

Combustible Gas Control System

Hydrogen Recombiner	WRD
Piping and Valves	UE&C
Charcoal Filter	UE&C

Chemical and Volume Control System

Regenerative Heat Exchanger	WRD
Letdown Heat Exchanger	WRD

SEABROOK STATION UFSAR	<p style="text-align: center;">QUALITY ASSURANCE TABLE 17.1-3</p>	Revision: 8 Sheet: 3 of 5
---------------------------------------	---	------------------------------

Contractor

Mixed Bed Demineralizer	UE&C
Cation Bed Demineralizer	UE&C
Reactor Coolant Filter	UE&C
Charging Pumps Centrifugal	WRD
Positive Displacement Charging Pump	WRD
Seal Water Injection Filter	UE&C
Excess Letdown Heat Exchanger	WRD
Seal Water Return Filter	UE&C
Seal Water Heat Exchanger	WRD
Boric Acid Tanks	UE&C
Boric Acid Transfer Pumps	WRD
Boric Acid Blender	UE&C
Boric Acid Filter	UE&C
Volume Control Tank	WRD
Bypass Orifice	WRD
Letdown Flow Control Valves	WRD
Boric Acid Transfer Pump Bypass Orifice	UE&C
Demineralizer Prefilter	UE&C
Letdown Strainers	UE&C
 <u>Boron Thermal Regeneration Subsystem</u>	
Moderating Heat Exchanger	WRD
Letdown Chiller Heat Exchanger	WRD
Letdown Ceheat Heat Exchanger	WRD
Thermal Regeneration Demineralizer	WRD

SEABROOK STATION UFSAR	QUALITY ASSURANCE TABLE 17.1-3	Revision: 8 Sheet: 4 of 5
---------------------------------------	-----------------------------------	------------------------------

Contractor

Safety Injection System

Refueling Water Storage Tank	UE&C
Accumulators	WRD
Boron Injection Tank	WRD
Boron Injection Tank Recirculation Pump	WRD
Boron Injection Surge Tank	WRD
Safety Injection Pump	WRD

Residual Heat Removal System

Residual Heat Removal Pump	WRD
Residual Heat Exchanger	WRD

<u>Waste Processing System (Gas Subsystem)</u>	UE&C
--	------

Primary Component Cooling Water System

Component Cooling Water Pumps	UE&C
Component Cooling Water Surge Tank	UE&C
Component Cooling Water Heat Exchangers	UE&C

Main Steam System

Main Steam Piping (from steam generator up to and including containment isolation valve)	UE&C
Safety Valves	UE&C
Atmospheric Dump Valve	UE&C

Steam Generator Blowdown System

Piping (up to and including isolation valve)	UE&C
--	------

SEABROOK STATION UFSAR	QUALITY ASSURANCE TABLE 17.1-3	Revision: 8 Sheet: 5 of 5
---------------------------------------	-----------------------------------	------------------------------

Contractor

Sample System

Isolation Valves	UE&C
Piping (up to and including isolation valves)	UE&C

Ventilation Cleanup and Air Conditioning Systems

Containment Enclosure Exhaust	UE&C
Diesel Generator Building Ventilation	UE&C
Battery Room Ventilation	UE&C
Control Room Air Conditioning	UE&C
Control Room Emergency Filters	UE&C
Fuel Storage Building Emergency Purge System	UE&C
Safeguard Pump Rooms Cooling	UE&C
Control Room Complex Makeup Air System	UE&C

Emergency Diesel Generator System

Diesel Fuel Storage Tank	UE&C
Diesel Fuel Day Tank	UE&C
Diesel Generator Air Tank	UE&C
Diesel Fuel Transfer Pump	UE&C
Diesel Fuel Filter	UE&C
Diesel Engines	UE&C

Spent Fuel Pool Cooling and Cleanup System

Spent Fuel Pool Pump	UE&C
Spent Fuel Pool Heat Exchanger	UE&C

SEABROOK STATION UFSAR	QUALITY ASSURANCE TABLE 17.1-4	Revision: 8 Sheet: 1 of 2
---------------------------------------	-----------------------------------	------------------------------

TABLE 17.1-4 SEABROOK STATION QUALITY ASSURANCE MANUAL COMPLIANCE WITH 10 CFR 50 APPENDIX B

<u>Table of Contents</u>	<u>Compliance with Applicable Section 10 CFR 50 Appendix B</u>
Preface	1,2
Table of Contents	
Definitions	
1.0 <u>Program</u>	
1.1 Design and Procurement	1 through 18
1.2 Construction	1 through 18
2.0 <u>Organization</u>	1
3.0 <u>Review Control</u>	
3.1 External Interface Controls	3,6
3.2 Review Control	3,6
3.3 Review Procedure	3,6
Appendix A - Engineering Specification	3
Appendix B - Engineering Drawing	3
Appendix C - Purchase Documents	3
Appendix D - QA/QC Program/Manual/Procedure	5
4.0 <u>Document Control</u>	
4.1 Project Document Control	5,6
4.2 Manual Control	5,6
5.0 <u>Purchased Material Control</u>	
5.1 Control of Purchased Material, Equipment and Services	4,7,8,10
8.0 <u>Corrective Action</u>	
8.1 Corrective Action	16

SEABROOK STATION UFSAR	<p style="text-align: center;">QUALITY ASSURANCE TABLE 17.1-4</p>	<p>Revision: 8 Sheet: 2 of 2</p>
---------------------------------------	---	--------------------------------------

Table of Contents

Compliance with Applicable
Section 10 CFR 50 Appendix B

9.0 Audits

9.1	General Audit Procedure	18
9.2	Internal Audits	18
9.4	General Surveillance Procedure	18

10.0 Records

SEABROOK STATION UFSAR	QUALITY ASSURANCE TABLE 17.1-5	Revision: 8 Sheet: 1 of 1
---------------------------------------	-----------------------------------	------------------------------

TABLE 17.1-5 SUPPLEMENTAL PROCEDURES

<u>Procedure</u>	<u>Proc. No.</u>
Administration of QA Program	WE-001
Indoctrination of Personnel	WE-003
Training	WE-004
Calculations and Analysis	WE-103
Computer Codes	WE-108
Quality Assurance Training	Q-101
QA Training Program	Q-102
Audit Primer	Q-103
Qualification and Certification of Inspection and Testing Personnel to ANSI N45.2.6	Q-106
Document Control Center Interface	Q-107
Quality Assurance for Fire Protection	Q-110
Project Policy Manual (Seabrook)	
Document Control Center Manual	
Seabrook Station Field Quality Assurance Manual and Procedure	
Procedure for Blast Monitoring	PSY Proc. 1
Procedure for Monthly Maintenance Program - Blast Monitoring Equipment	
Procedure for Operator Training Program (Blast Monitoring)	PSY Proc. 3
Procedure for Control of YAEC Generated Procedures (Site Related)	PSY Proc. 4
Procedure for Geological Mapping Program	PSY Proc. 5
Procedure for Procurement Control	PSY Proc. 6

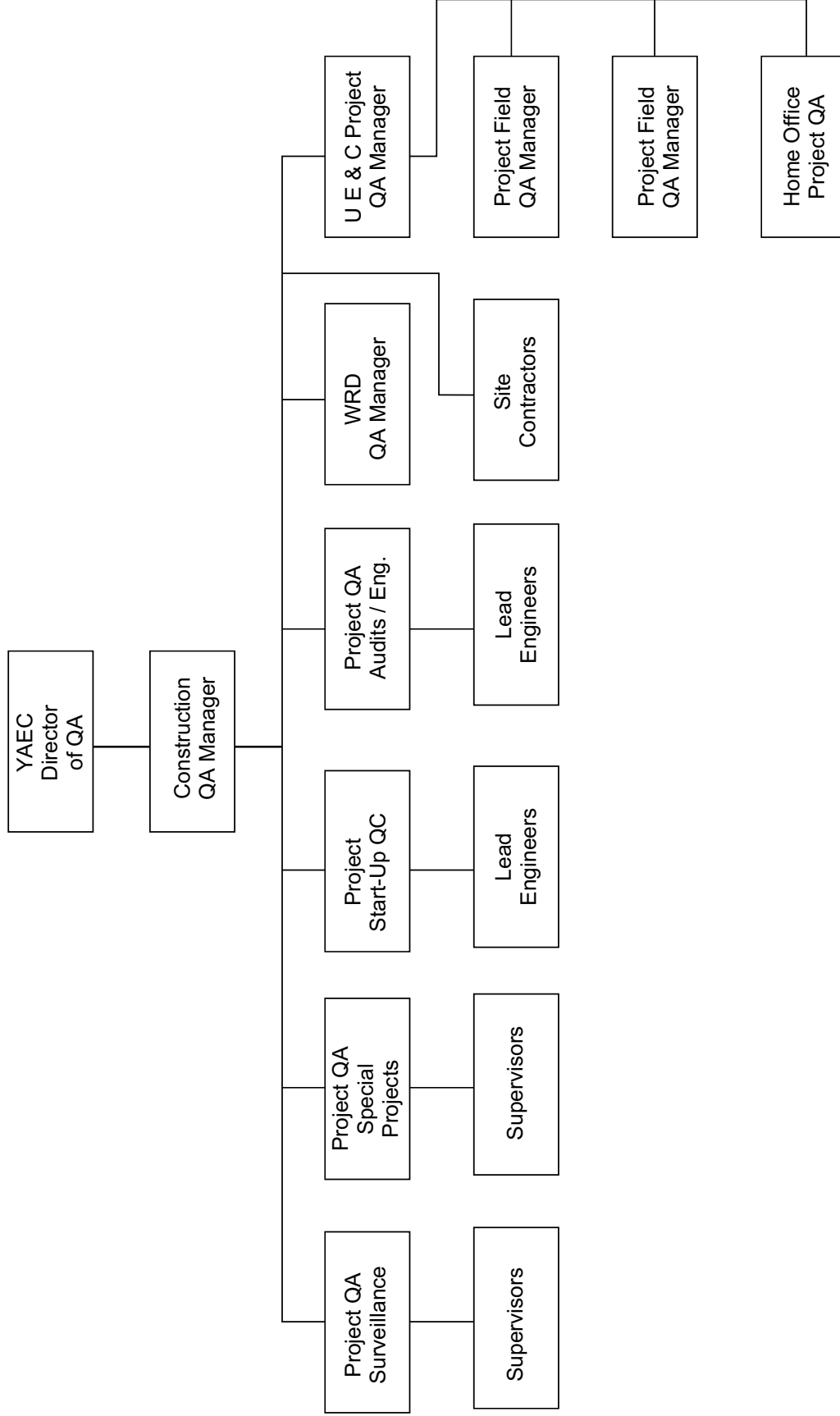

G:\Word\Images_PUF SAR\1711 .ds4

SEABROOK STATION UPDATED FINAL SAFETY ANALYSIS REPORT	YAEC Quality Assurance Interfaces
	Figure 17.1-1

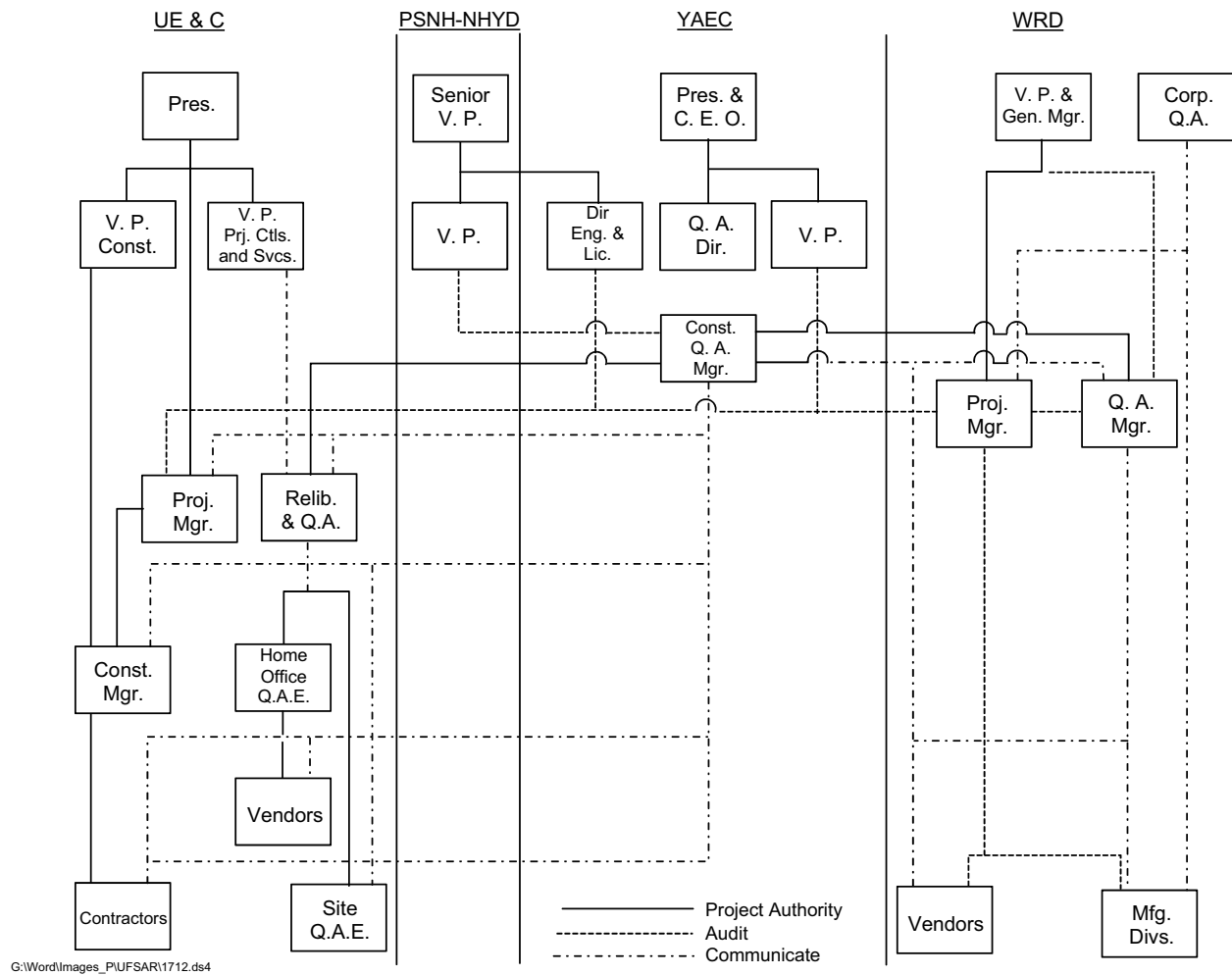

SEABROOK STATION UPDATED FINAL SAFETY ANALYSIS REPORT	Composite Quality Assurance Interfaces	
		Figure 17.1-2

Deleted

SEABROOK STATION UPDATED FINAL SAFETY ANALYSIS REPORT	Nuclear Quality Assurance Interfaces	
		Figure 17.2-1

SEABROOK STATION UFSAR	QUALITY ASSURANCE Exceptions, Alternatives, And Clarifications To Program Standards, Industry Codes, Federal Regulations And Guides	Revision 11 Appendix 17A Page 1
---------------------------------------	---	---------------------------------------

**17A EXCEPTIONS, ALTERNATIVES, AND CLARIFICATIONS TO
PROGRAM STANDARDS, INDUSTRY CODES, FEDERAL
REGULATIONS AND GUIDES**

General

This information is located in the FPL Quality Assurance Topical Report.

SEABROOK STATION UFSAR	QUALITY ASSURANCE - Deleted -	Revision 8 Appendix 17B Page 1
---------------------------------------	---	--------------------------------------

17B DELETED

SEABROOK STATION UFSAR	QUALITY ASSURANCE Company Nuclear Review Board (CNRB)	Revision 11 Appendix 17C Page 1
---------------------------------------	--	---------------------------------------

17C COMPANY NUCLEAR REVIEW BOARD (CNRB)

17C.1 FUNCTION

The CNRB functions have been transferred to the Station Operation Review Committee as described in the FPL Quality Assurance Topical Report.

SEABROOK STATION UFSAR	QUALITY ASSURANCE Administrative Controls	Revision 11 Appendix 17D Page 1
---------------------------------------	--	---------------------------------------

17D ADMINISTRATIVE CONTROLS

17D.1 INDEPENDENT TECHNICAL REVIEWS

These reviews are described in the Quality Assurance Topical Report.

17D.2 REVIEW AND AUDIT

17D.2.1 Station Operation Review Committee (SORC)

The SORC is described in the Quality Assurance Topical Report.

17D.2.2 Station Qualified Reviewer Program

The Station Qualified Reviewer Program is described in the Quality Assurance Topical Report.

17D.2.3 Procedures and Programs

Written procedures are described in the Quality Assurance Topical Report.

17D.3 RECORD RETENTION

Record retention is described in the Quality Assurance Topical Report.