

ENCLOSURE 3

OFFSITE DOSE CALCULATION MANUAL
REVISION 51

SEQUOYAH NUCLEAR PLANT

Attachment 3.0

Radiation Monitors Inoperable for Greater than 30 days

ERCW Radiation Monitors (0-RM-90-133/140) (PER 113783) were out of service from Sept. 27 to Nov. 9 due to the following: during surveillance testing 120 VAC Vital Instrument Power breaker #45 of board 1-1 tripped instantaneously as 0-RM-90-133 sample pump was being restarted. The motor associated with the sample pump was replaced under WO 06-779220-000 with a like for like motor and the same breaker tripped instantaneously again. This breaker and motor was replaced in May 2006 for this same tripping condition under WO 06-773966-000. Based on field data taken under WO 06-779220-000 the breaker for ERCW radiation monitor 0-RM-90-133 appeared to be undersized for this motor/pump sampling application. The apparent cause was later determined to be an incorrect Vital Board breaker installed by maintenance that caused the motor to trip early. Reference, PER 113150 and PER 113783. Since the breaker could not be replaced with Unit 1 online, a work order plan was developed to parallel two breakers during the startup of the motor and then return the wiring to the normal design. Implementation of this sensitive evaluation took some time to approve and implement due to its complexity.

Compliance Instruments Inoperable for greater than 30 days

0-LS-27-225 (Cooling Tower Blowdown Effluent Line) PER 85280.

SEQUOYAH NUCLEAR PLANT
OFFSITE DOSE CALCULATION MANUAL

Revision 51

Prepared By: W. Kenneth Kimsey

Sponsor: Debra J. Bodine **Date:** 11/24/2006

PORC Review: Mark H. Palmer **Date:** 11/24/2006

Approval--Plant Manager: David A. Kulisek **Date:** 11/24/2006

Effective Date: 11/24/2006

SEQUOYAH NUCLEAR PLANT
OFFSITE DOSE CALCULATION MANUAL
REVISION LOG
(Page 1 of 2)

Revision	Approval Date	Revision	Approval Date	Effective Date
Original ODCM	2/29/80 ¹	Revision 28	9/22/92 ^b	12/1/92
Revision 1	4/15/80 ²	Revision 29	3/30/93 ²	
Revision 2	10/7/80 ²	Revision 30	9/30/93 ²	
Revision 3	11/3/80, 2/10/81, 4/8/81, 6/4/81 ²	Revision 31	10/13/93 ²	
Revision 4	10/22/81, 11/28/81, 4/29/82, 11/22/82 ²	Revision 32	11/29/93 ²	1/1/94
Revision 5	10/21/82 ²	Revision 33	2/25/94 ²	
Revision 6	1/20/83 ²	Revision 34	4/29/94 ²	5/15/94
Revision 7	3/23/83 ²	Revision 35	10/20/94 ^b	11/15/94
Revision 8	12/16/83 ²	Revision 36	7/20/95 ^b	8/4/95
Revision 9	3/7/84 ²	Revision 37	10/26/95 ^b	11/6/95
Revision 10	4/24/84 ²	Revision 38	2/15/96 ^b	2/23/96
Revision 11	8/21/84	Revision 39	11/12/96 ^b	1/17/97
Revision 12	2/19/85 ²	Revision 40	4/2/98 ^b	4/23/98
Revision 13	12/02/85 ²	Revision 41	8/7/98	8/11/98
Revision 14	4/14/86 ²	Revision 42	4/29/99	4/30/99
Revision 15	11/5/86 ³	Revision 43	4/29/99	4/30/99
Revision 16	1/16/87 ²	Revision 44	6/17/99 ^b	6/21/99
Revision 17	10/28/87 ²	Revision 45	2/17/00 ^b	3/1/00
Revision 18	1/5/88 ²	Revision 46	10/6/01	10/9/01
Revision 19	3/30/88 ²	Revision 47	1/13/03	1/15/03
Revision 20	7/19/88 ²	Revision 48	8/21/05	8/21/05
Revision 20A	12/14/88 ²	Revision 49	5/17/06	5/23/06
Revision 21	2/15/89 ²	Revision 50	9/29/06	9/29/06
Revision 22	6/1/89 ²			
Revision 23	6/28/89, 9/15/89 ⁴			
Revision 25	11/2/90, 4/24/91 ²			
Revision 26	1/17/92 ^b			
Revision 27	4/15/92 ²			
Revision 28	9/22/92 ^b			

¹ Low power license for Sequoyah Unit 1.

² RARC Meeting Date.

³ Date approved by RARC Chairman.

⁴ Revision 23 implements the Nuclear Data Effluent Management Software. This ODCM revision and the software will be implemented concurrently on October 9, 1989. Releases made during the month of October prior to the software implementation will be backfitted to comply with this revision.

⁵ Revision 26 was recommended for approval by the SQN RARC at the October 2, 1991 meeting. The revision date is January 17, 1992. The final implementation date for Revision 26 will be March 17, 1992.

⁶ PORC Meeting Date.

INTRODUCTION	9
1/2 CONTROLS AND SURVEILLANCE REQUIREMENTS	12
1/2.0 APPLICABILITY	12
1/2.1 INSTRUMENTATION.....	14
1/2.1.1 RADIOACTIVE LIQUID EFFLUENT MONITORING INSTRUMENTATION	14
TABLE 1.1-1 RADIOACTIVE LIQUID EFFLUENT MONITORING INSTRUMENTATION	15
TABLE 2.1-1 - RADIOACTIVE LIQUID EFFLUENT MONITORING INSTRUMENTATION SURVEILLANCE REQUIREMENTS	17
1/2.1.2 RADIOACTIVE GASEOUS EFFLUENT MONITORING INSTRUMENTATION.....	19
TABLE 1.1-2 RADIOACTIVE GASEOUS EFFLUENT MONITORING INSTRUMENTATION.....	20
TABLE 2.1-2 RADIOACTIVE GASEOUS EFFLUENT MONITORING INSTRUMENTATION SURVEILLANCE REQUIREMENTS.....	23
1/2.2 RADIOACTIVE EFFLUENTS	25
1/2.2.1 LIQUID EFFLUENTS.....	25
1/2.2.1.1 CONCENTRATION.....	25
TABLE 2.2-1 RADIOACTIVE LIQUID WASTE SAMPLING AND ANALYSIS PROGRAM.....	26
1/2.2.1.2 DOSE	29
1/2.2.1.3 LIQUID RADWASTE TREATMENT SYSTEM	30
1/2.2.2 GASEOUS EFFLUENTS	31
1/2.2.2.1 DOSE RATE.....	31
TABLE 2.2-2 RADIOACTIVE GASEOUS WASTE MONITORING SAMPLING AND ANALYSIS PROGRAM	32
1/2.2.2.2 DOSE - NOBLE GASES	35
1/2.2.2.3 DOSE - I-131, I-133, TRITIUM AND RADIONUCLIDES IN PARTICULATE FORM WITH HALF-LIVES GREATER THAN EIGHT DAYS	36
1/2.2.2.4 GASEOUS RADWASTE TREATMENT	37
1/2.2.3 TOTAL DOSE	38
1/2.3 RADIOLOGICAL ENVIRONMENTAL MONITORING	39
1/2.3.1 MONITORING PROGRAM	39
TABLE 2.3-1 MINIMUM REQUIRED RADIOLOGICAL ENVIRONMENTAL MONITORING PROGRAM	41
TABLE 2.3-2 REPORTING LEVELS FOR RADIOACTIVITY CONCENTRATIONS IN ENVIRONMENTAL SAMPLES.....	43
TABLE 2.3-3 MAXIMUM VALUES FOR THE LOWER LIMITS OF DETECTION (LLD) ^{A,B}	44
1/2.3.2 LAND USE CENSUS.....	46
1/2.3.3 INTERLABORATORY COMPARISON PROGRAM.....	48
BASES	50
INSTRUMENTATION.....	50
1/2.1.1 RADIOACTIVE LIQUID EFFLUENT MONITORING INSTRUMENTATION	50
1/2.1.2 RADIOACTIVE GASEOUS EFFLUENT MONITORING INSTRUMENTATION	50
1/2.2 RADIOACTIVE EFFLUENTS	50
1/2.2.1.1 CONCENTRATION.....	50
1/2.2.1.2 DOSE	50
1/2.2.1.3 LIQUID RADWASTE TREATMENT SYSTEM	51
1/2.2.2.1 DOSE RATE.....	51
1/2.2.2.2 DOSE - NOBLE GASES.....	52

1/2.2.2.3 DOSE - I-131, I-133, TRITIUM, AND RADIONUCLIDES IN PARTICULATE FORM WITH HALF-LIVES GREATER THAN EIGHT DAYS	52
1/2.2.2.4 GASEOUS RADWASTE TREATMENT	53
1/2.2.3 TOTAL DOSE	53
1/2.3 RADIOLOGICAL ENVIRONMENTAL MONITORING	54
1/2.3.1 MONITORING PROGRAM	54
1/2.3.2 LAND USE CENSUS.....	54
1/2.3.3 INTERLABORATORY COMPARISON PROGRAM	54
3.0 DEFINITIONS	56
3.1 ACTION.....	56
3.2 CHANNEL CALIBRATION.....	56
3.3 CHANNEL CHECK	56
3.4 CHANNEL FUNCTIONAL TEST.....	56
3.6 CONTROLLED AREA	56
3.7 DOSE EQUIVALENT I-131	56
3.9 GASEOUS RADWASTE TREATMENT SYSTEM	57
3.10 OPERABLE - OPERABILITY	57
3.11 MODE.....	57
3.12 PURGE - PURGING.....	57
3.13 RADIATION MONITOR (RM) OR (R)	57
3.14 RATED THERMAL POWER	57
3.16 RESTRICTED AREA.....	58
3.17 SITE BOUNDARY.....	58
3.18 SOURCE/SENSOR CHECK	58
3.19 UNRESTRICTED AREA/BOUNDARY	58
3.20 VENTILATION EXHAUST TREATMENT SYSTEM.....	58
3.21 VENT FLOW RATE MONITOR (F).....	58
3.22 VENTING	58
TABLE 3.1 FREQUENCY NOTATION.....	59
FIGURE 3.1 UNRESTRICTED AREA BOUNDARY	60
5.0 ADMINISTRATIVE CONTROLS	63
5.1 ANNUAL RADIOLOGICAL ENVIRONMENTAL OPERATING REPORT	63
5.2 ANNUAL RADIOACTIVE EFFLUENT RELEASE REPORT	63
5.3 OFFSITE DOSE CALCULATION MANUAL CHANGES	65
5.4 SPECIAL REPORTS	65
SECTION 6.0 LIQUID EFFLUENTS.....	67
RELEASE POINTS	67
6.1 LIQUID RELEASES	69
6.1.1 PRE-RELEASE ANALYSIS	69
6.1.2 EFFLUENT CONCENTRATION LIMITS (ECL)-SUM OF THE RATIOS	69
6.1.3 POST-RELEASE ANALYSIS	70
6.2 INSTRUMENT SETPOINTS	71
6.2.1 DISCHARGE POINT MONITOR SETPOINTS (0-RM-90-133,134,140,141)	71
6.2.2 RELEASE POINT MONITOR SETPOINTS (0-RM-90-122; 0-RM-90-225; 0-RM-90-212; 1,2-RM-90-120,121)...	71
6.2.3 BATCH RELEASE POINT MONITOR SETPOINT	71
6.3 CUMULATIVE LIQUID EFFLUENT DOSE CALCULATIONS	72
6.3.1 MONTHLY DOSE CALCULATIONS	74
6.3.2 CUMULATIVE DOSES.....	74
6.3.3 COMPARISON TO LIMITS	74
6.4 LIQUID RADWASTE TREATMENT SYSTEM	75

6.5 DOSE PROJECTIONS	76
6.6 QUARTERLY DOSE CALCULATIONS.....	77
6.6.1 WATER INGESTION	77
6.6.2 FISH INGESTION.....	78
6.6.3 SHORELINE RECREATION	78
6.6.4 TOTAL MAXIMUM INDIVIDUAL DOSE	79
6.6.5 POPULATION DOSES	79
6.7 LIQUID DOSE FACTOR EQUATIONS	82
6.7.1 WATER INGESTION	82
6.7.2 FISH INGESTION.....	82
6.7.3 SHORELINE RECREATION	82
TABLE 6.1 RECEPTORS FOR LIQUID DOSE CALCULATIONS	83
TABLE 6.2 RADIONUCLIDE DECAY AND STABLE ELEMENT TRANSFER DATA.....	84
TABLE 6.3 DOSE CALCULATION FACTORS	87
TABLE 6.4 INGESTION DOSE FACTORS	89
TABLE 6.5 BIOACCUMULATION FACTORS FOR FRESHWATER FISH	97
TABLE 6.6 EXTERNAL DOSE FACTORS FOR STANDING ON CONTAMINATED GROUND.....	98
FIGURE 6.1 LIQUID EFFLUENT RELEASE POINTS	100
FIGURE 6.2 LIQUID RADWASTE SYSTEM	101
SECTION 7.0 GASEOUS EFFLUENTS	103
RELEASE POINTS DESCRIPTION	103
7.1 INSTRUMENT SETPOINTS	104
7.1.1 RELEASE POINT MONITOR SETPOINTS (1,2-RM-90-130,-131, 0-RM-90-118).....	104
7.1.1.1 CONTAINMENT PURGE EFFLUENT MONITORS (1,2-RM-90-130,-131).....	104
7.1.1.2 WASTE GAS DECAY TANK EFFLUENT MONITOR (0-RM-90-118).....	104
7.1.2 DISCHARGE POINT MONITOR SETPOINTS (1,2-RE-90-400, 0-RM-90-101, 0-RM-90-132, 1,2-RM-90-99,119).....	106
7.1.3 CONDENSER VACUUM EXHAUST VENT (1,2-RM-90-99,119)	106
7.2 GASEOUS EFFLUENTS - DOSE RATES	113
7.2.1 (DELETED).....	107
7.2.2 RELEASE SAMPLING.....	107
7.2.3 NOBLE GAS DOSE RATES	107
7.2.3.1 TOTAL BODY DOSE RATE	107
7.2.3.2 SKIN DOSE RATE	108
7.2.4 I-131, I-133, TRITIUM AND ALL RADIONUCLIDES IN PARTICULATE FORM WITH HALF-LIVES OF GREATER THAN 8 DAYS - ORGAN DOSE RATE	109
7.3 DOSE - NOBLE GASES	110
7.3.1 GAMMA DOSE TO AIR	110
7.3.2 BETA DOSE TO AIR.....	110
7.3.3 CUMULATIVE DOSE - NOBLE GAS	111
7.3.4 COMPARISON TO LIMITS	111
7.4 DOSE DUE TO I-131, I-133, TRITIUM AND ALL RADIONUCLIDES IN PARTICULATE FORM WITH HALF-LIVES OF GREATER THAN 8 DAYS.....	112
7.4.1 ORGAN DOSE CALCULATION.....	112
7.4.2 CUMULATIVE DOSES.....	113
7.4.3 COMPARISON TO LIMITS	113
7.5 DOSE PROJECTIONS	114
7.5.1 GASEOUS RADWASTE TREATMENT SYSTEM DESCRIPTION	114

7.6 QUARTERLY DOSE CALCULATIONS.....	115
7.6.1 NOBLE GAS - GAMMA AIR DOSE	115
7.6.2 NOBLE GAS - BETA AIR DOSE	115
7.6.3 RADIOIODINE, PARTICULATE AND TRITIUM - MAXIMUM ORGAN DOSE	116
7.6.4 POPULATION DOSES	117
7.6.4 POPULATION DOSES (CONTINUED)	118
7.6.5 REPORTING OF DOSES.....	118
7.6.6 DOSE TO A MEMBER OF THE PUBLIC INSIDE THE UNRESTRICTED OR RESTRICTED AREA BOUNDARY	118
7.7 GASEOUS RELEASES - Dose Factors	119
7.7.1 PASTURE GRASS-COW/GOAT-MILK INGESTION DOSE FACTORS	119
7.7.2 STORED FEED-COW/GOAT-MILK INGESTION DOSE FACTORS	120
7.7.3 PASTURE GRASS-BEEF INGESTION DOSE FACTORS.....	121
7.7.4 STORED FEED-BEEF INGESTION DOSE FACTORS.....	122
7.7.5 FRESH LEAFY VEGETABLE INGESTION DOSE FACTORS	123
7.7.6 STORED VEGETABLE INGESTION DOSE FACTORS	124
7.7.7 TRITIUM-PASTURE GRASS-COW/GOAT-MILK DOSE FACTOR.....	125
7.7.8 TRITIUM-STORED FEED-COW/GOAT-MILK DOSE FACTOR	125
7.7.9 TRITIUM-PASTURE GRASS-BEEF DOSE FACTOR	126
7.7.10 TRITIUM-STORED FEED-BEEF DOSE FACTOR	126
7.7.11 TRITIUM-FRESH LEAFY VEGETABLES DOSE FACTOR.....	127
7.7.12 TRITIUM-STORED VEGETABLES DOSE FACTOR.....	128
7.7.13 INHALATION DOSE FACTORS.....	128
7.7.14 GROUND PLANE DOSE FACTORS	128
7.8 DISPERSION METHODOLOGY.....	129
7.8.1 AIR CONCENTRATION	129
7.8.2 RELATIVE CONCENTRATION	130
7.8.3 RELATIVE DEPOSITION	131
TABLE 7.3 DOSE FACTORS FOR SUBMERSION IN NOBLE GASES	134
TABLE 7.4 SECTOR ELEMENTS CONSIDERED FOR POPULATION DOSES	135
TABLE 7.5 POPULATION WITHIN EACH SECTOR ELEMENT.....	136
TABLE 7.6 INHALATION DOSE FACTORS.....	137
FIGURE 7.1 GASEOUS EFFLUENT RELEASE POINTS	145
FIGURE 7.2 AUXILIARY AND SHIELD BUILDING VENTS (DETAIL).....	146
FIGURE 7.3 GASEOUS RADWASTE TREATMENT SYSTEM.....	147
FIGURE 7.4 PLUME DEPLETION EFFECT FOR GROUND LEVEL RELEASES	148
.....	148
FIGURE 7.5 VERTICAL STANDARD DEVIATION OF MATERIAL IN A PLUME	149
.....	149
FIGURE 7.6 RELATIVE DEPOSITION FOR GROUND LEVEL RELEASES	150
SECTION 8.0 TOTAL DOSE.....	152
8.1 ANNUAL MAXIMUM INDIVIDUAL DOSES - TOTAL REPORTED DOSE	152
SECTION 9.0 RADIOLOGICAL ENVIRONMENTAL MONITORING PROGRAM.....	154
9.1 MONITORING PROGRAM	154
9.2 DETECTION CAPABILITIES.....	154
9.3 LAND USE CENSUS.....	154
9.4 INTERLABORATORY COMPARISON PROGRAM.....	154
TABLE 9.1 RADIOLOGICAL ENVIRONMENTAL MONITORING PROGRAM	155
TABLE 9.2 ENVIRONMENTAL RADIOLOGICAL MONITORING PROGRAM SAMPLING LOCATIONS	159
TABLE 9.3 THERMOLUMINESCENT DOSIMETRY LOCATIONS.....	160
FIGURE 9.1 ENVIRONMENTAL MONITORING LOCATIONS WITHIN ONE MILE OF THE PLANT	162

FIGURE 9.2 ENVIRONMENTAL MONITORING LOCATIONS FROM ONE TO FIVE MILES FROM THE PLANT ..163
FIGURE 9.3 ENVIRONMENTAL MONITORING LOCATIONS GREATER THAN FIVE MILES FROM THE PLANT 164
APPENDIX A - SQN ODCM REVISION PROCESS165

INTRODUCTION

This Offsite Dose Calculation Manual (ODCM) is in support of the Tennessee Valley Authority (TVA) facility operating licenses for a two-unit nuclear power plant located approximately 7.5 miles northeast of Chattanooga at the Sequoyah site in Hamilton County, Tennessee.

This facility has been designated the Sequoyah Nuclear Plant (SQN). The plant has been designed, built, and is operated by TVA. Each of the two identical units employs a Pressurized Water Reactor Nuclear Steam Supply System (NSSS) with four coolant loops furnished by Westinghouse Electric Corporation.

Each of the two reactor cores is rated at 3,455 MWt and, at this core power, the NSSS will operate at 3,467 MWt. The additional 12 MWt is due to the contribution of heat of the Primary Coolant System from nonreactor sources, primarily reactor coolant pump heat. Each of the reactor cores has an Engineered Safeguards Design rating of 3577 MWt and at this core power, the NSSS will operate at 3565 MWt. The net electrical output is 1211 Mwe for Unit 1 and 1188 Mwe for Unit 2 at the rated core power. All plant safety systems, including containment and engineered safety features, are designed and evaluated at the higher power level. In addition, the higher power rating is used in the analysis of postulated accidents having as a consequence the release of fission product activity to the environment.

The containment for each of the reactors consists of a freestanding steel vessel with an ice condenser and separate reinforced concrete shield building. The freestanding steel vessel and the concrete shield building were designed by TVA and the ice condenser was furnished by the Westinghouse Electric Corporation.

Unit 1 began commercial operation on July 1, 1981. Unit 2 began commercial operation on June 1, 1982.

The ODCM is divided into two major parts. The first part of the ODCM contains:

1. Radioactive Effluent Controls required by Section 6.8.4.f of the SQN Technical Specifications; 2) Radiological Environmental Monitoring Controls; 3) descriptions of the information that should be included in the Annual Radiological Environmental Operating and Annual Radioactive Effluent Release Reports required by SQN Technical Specifications 6.9.1.6 and 6.9.1.8; and, 4) Administrative Controls for the ODCM requirements.

The second part of the ODCM contains the methodologies used to: 1) calculate offsite doses resulting from radioactive gaseous and liquid effluents to the unrestricted area/boundary and the Tennessee River; 2) calculate gaseous and liquid effluent monitor Alarm/Trip setpoints; and, 3) conduct the Environmental Radiological Monitoring Program.

The SQN ODCM will be maintained for use as a reference guide on accepted methodologies and calculations. Changes in the calculation methods or parameters will be incorporated into the ODCM in order to assure that the ODCM represents the present methodology in all applicable areas. Any licensee initiated ODCM changes will be implemented in accordance with SQN Technical Specification 6.14 and ODCM Administrative Control 5.3.

SECTIONS 1.0 AND 2.0
CONTROLS AND
SURVEILLANCE REQUIREMENTS

1/2 CONTROLS AND SURVEILLANCE REQUIREMENTS

1/2.0 APPLICABILITY

CONTROLS

- 2.1.1. Compliance with the Controls contained in the succeeding controls is required during the OPERATIONAL MODES or other conditions specified therein; except that upon failure to meet the Control, the associated ACTION requirements shall be met.
- 2.1.2. Noncompliance with a Control shall exist when the requirements of the Control and associated ACTION requirements are not met within the specified time intervals. If the Control is restored prior to the expiration of the specified intervals, completion of the ACTION requirements is not required.
- 2.1.3. When a Control is not met, except as provided in the associated ACTION requirements, within 1 hour action shall be initiated to place the unit in a MODE in which the Control does not apply by placing it, as applicable, in:
- a. At least HOT STANDBY within the next 6 hours,
 - b. At least HOT SHUTDOWN within the following 6 hours, and
 - c. At least COLD shutdown within the subsequent 24 hours.
- 2.1.4. Entry into an OPERATIONAL MODE or other specified condition shall not be made when the conditions for the Control are not met and the associated ACTION requires a shutdown if they are not met within a specified time interval. Entry into an OPERATIONAL MODE or specified condition may be made in accordance with ACTION requirements when conformance to them permits continued operation of the facility for an unlimited period of time. This provision shall not prevent passage through or to OPERATIONAL MODES as required to comply with the ACTION requirements. Exceptions to these requirements are stated in the individual Controls.

1/2 CONTROLS AND SURVEILLANCE REQUIREMENTS

1/2.0 APPLICABILITY

SURVEILLANCE REQUIREMENTS

- 2.1.1. Surveillance Requirements shall be met during the OPERATIONAL MODES or other conditions specified for individual Controls unless otherwise stated in the individual Surveillance Requirement.
- 2.1.2. Each Surveillance Requirement shall be performed within the specified time interval with a maximum allowable extension not to exceed 25% of the specified surveillance interval.
If an ACTION requires periodic performance on a "once per ..." basis, the above frequency extension applies to each performance after the initial performance.
- 2.1.3. Failure to perform a Surveillance Requirement within the specified time interval shall constitute a failure to meet the OPERABILITY requirements for a Control. The time limits of the ACTION requirements are applicable at the time it is identified that a Surveillance Requirement has not been performed. The ACTION requirements may be delayed for up to 24 hours to permit the completion of the surveillance when the allowable outage time limits of the ACTION requirements are less than 24 hours. Surveillance Requirements do not have to be performed on inoperable equipment.
- 2.1.4. Entry into an OPERATIONAL MODE or other specified applicable condition shall not be made unless the Surveillance Requirement(s) associated with the Control has been performed within the applicable surveillance interval or as otherwise specified. This provision shall not prevent passage through or to OPERATIONAL MODES as required to comply with ACTION requirements. Exceptions to these requirements are stated in the individual Controls.

1/2 CONTROLS AND SURVEILLANCE REQUIREMENTS

1/2.1 INSTRUMENTATION

1/2.1.1 RADIOACTIVE LIQUID EFFLUENT MONITORING INSTRUMENTATION

CONTROLS

2.1.1. In accordance with SQN Technical Specification 6.8.4.f.1, the radioactive liquid effluent monitoring instrumentation channels shown in Table 1.1-1 shall be OPERABLE with their alarm/trip setpoints set to ensure that the limits of ODCM Control 1.2.1.1 are not exceeded. The alarm/trip setpoints of these channels shall be determined in accordance with the methodology and parameters in ODCM Section 6.2.

APPLICABILITY: This requirement is applicable during all releases via these pathways.

ACTION:

- a. With a radioactive liquid effluent monitoring instrumentation channel alarm/trip setpoint less conservative than required above, without delay suspend the release of radioactive liquid effluents monitored by the affected channel or declare the channel inoperable, or change the setpoint so that it is acceptably conservative.
- b. With less than the minimum number of radioactive liquid effluent monitoring instrumentation channels OPERABLE, take the action shown in Table 1.1-1. Restore the inoperable instruments to OPERABLE status within 30 days and, if unsuccessful, explain in the next Annual Radioactive Effluent Release Report pursuant to ODCM Administrative Control 5.2, why the inoperability could not be corrected within 30 days.
- c. The provisions of Controls 1.0.3 and 1.0.4 are not applicable. Report all deviations in the Annual Radioactive Effluent Release Report.

SURVEILLANCE REQUIREMENTS

2.1.1. Each radioactive liquid effluent monitoring channel shall be demonstrated OPERABLE by performance of the CHANNEL CHECK, SOURCE/SENSOR CHECK, CHANNEL CALIBRATION, and CHANNEL FUNCTIONAL TEST operations at the frequencies shown in Table 2.1-1.

Table 1.1-1 RADIOACTIVE LIQUID EFFLUENT MONITORING INSTRUMENTATION
(Page 2 of 2) TABLE NOTATION

- ACTION 30 - With the number of channels OPERABLE less than required by the Minimum Channels OPERABLE requirement, effluent releases may continue provided that prior to initiating a release:
- At least two independent samples of the tank's contents obtained by two technically qualified members of the facility staff are analyzed, and
 - At least two technically qualified members of the Facility Staff independently verify the release rate calculations and;
 - At least two technically qualified members of the Facility Staff independently verify the discharge valve lineup.
- Otherwise, suspend release of radioactive effluents via this pathway.
- ACTION 31 - With the number of channels OPERABLE less than required by the Minimum Channels OPERABLE requirement, effluent releases via this pathway may continue provided grab samples are analyzed for principal gamma emitters in accordance with SR 2.2.1.1.1 and 2.2.1.1.2.
- At least once per 12 hours when the specific activity of the secondary coolant is greater than or equal to 0.01 $\mu\text{Ci/g}$ DOSE EQUIVALENT I-131.
 - At least once per 24 hours when the specific activity of the secondary coolant is less than 0.01 $\mu\text{Ci/g}$ DOSE EQUIVALENT I-131.
- ACTION 32 - With the number of channels OPERABLE less than required by the Minimum Channels OPERABLE requirement, effluent releases via this pathway may continue provided that, at least once per 12 hours, grab samples are collected and analyzed for principal gamma emitters at a limit of detection of at least 5.0×10^{-7} $\mu\text{Ci/ml}$.
- ACTION 33 - With the number of channels OPERABLE less than required by the Minimum Channels OPERABLE requirement, effluent releases via this pathway may continue provided the flow rate is estimated at least once per 4 hours during actual releases. Pump curves or the change in tank level indication, if applicable, may be used to estimate flow.
- ACTION 35 - With the number of channels OPERABLE less than required by the Minimum Channels OPERABLE requirement, effluent releases via this pathway may continue provided representative batch samples of each tank to be released are taken prior to release and composited for analysis according to Table 2.2-1, footnote g.

Table 2.1-1 - RADIOACTIVE LIQUID EFFLUENT MONITORING INSTRUMENTATION SURVEILLANCE REQUIREMENTS
(Page 1 of 2)

Instrument	CHANNEL CHECK	SOURCE/ SENSOR CHECK	CHANNEL CALIBRATION	CHANNEL FUNCTIONAL TEST
1. Gross Beta or Gamma Radioactivity Monitors Providing Alarm and Automatic Termination of Release				
a. Liquid Radwaste Effluent Line (0-RM-90-122)	D	P	R(3)	Q(1)
b. Steam Generator Blowdown Effluent Line (1,2-RM-90-120A,121A)	D	M	R(3)	Q(5)
c. Condensate Demineralizer Effluent Line (0-RM-90-225A)	D	M	R(3)	Q(5)
2. Gross Beta or Gamma Radioactivity Monitors Providing Alarm But Not Providing Automatic Termination of Release				
a. Essential Raw Cooling Water Effluent Line (0-RM-90-133A,134A,140A,141A)	D	M	R(3)	Q(2)
b. Turbine Building Sump Effluent Line (0-RM-90-212A)	D	M	R(3)	Q(2)
3. Flow Rate Measurement Devices				
a. Liquid Radwaste Effluent Line (0-FI-77-42)	D(4)	N.A.	R	Q
b. Steam Generator Blowdown Effluent Line (1,2-FI-15-44, 1,2-F-15-43)	D(4)	N.A.	R	Q
c. Condensate Demineralizer Effluent Line (0-FR-14-456,0-F-14-192, 0-F-14-185)	D(4)	N.A.	R	Q
d. Cooling Tower Blowdown Effluent Line Available Dilution Flow is provide by ICS Computer Point 0F2102DIF. This computer point receives input From flow transmitters 1,2-FT-67-61 and 1,2-FT-67-62.	D(4)	N.A.	N.A	N.A
e. 1,2-FT-67-61 and 62.	N.A.	N.A.	R	N.A.
f. Turbine Building Sump Discharge 0-F-40-3	D(4)	N.A	R.	N.A
4. Continuous Composite Sampler and Sample Flow Monitor				
a. Condensate Demineralizer Regenerant Effluent Line (0-FI-14-466)	P	N.A.	R	N.A.

Table 2.1-1 RADIOACTIVE LIQUID EFFLUENT MONITORING INSTRUMENTATION SURVEILLANCE
REQUIREMENTS
(Page 2 of 2)

* During liquid additions to the tank.

- (1) The CHANNEL FUNCTIONAL TEST shall also demonstrate that automatic isolation of this pathway and control room alarm annunciation occurs if any of the following conditions exists:
 1. Instrument indicates measured levels above the alarm/trip setpoint.
 2. Circuit failure.
 3. Downscale failure.
- (2) The CHANNEL FUNCTIONAL TEST shall also demonstrate that control room alarm annunciation occurs if any of the following conditions exists:
 1. Instrument indicates measured levels above an alarm setpoint.
 2. Circuit failure.
 3. Downscale failure.
- (3) The initial CHANNEL CALIBRATION shall be performed using one or more of the reference standards certified by the National Institute of Standards and Technology (NIST) or using standards that have been obtained from suppliers that participate in measurement assurance activities with NIST. These standards shall permit calibrating the system over its intended range of energy and measurement range. For subsequent CHANNEL CALIBRATION, sources that have been related to the initial calibration shall be used.
- (4) CHANNEL CHECK shall consist of verifying indication of flow during periods of release. CHANNEL CHECK shall be made at least once per 24 hours on days on which continuous periodic, or batch releases are made.
- (5) The CHANNEL FUNCTIONAL TEST shall also demonstrate that automatic isolation of this pathway and control room alarm annunciation occurs if any of the following conditions occur:
 1. Instrument indicates measured levels above an alarm/trip setpoint.
 2. Circuit failure.

The CHANNEL FUNCTIONAL TEST shall also demonstrate that control room annunciation occurs if the following condition occurs:

1. Downscale failure.

1/2 CONTROLS AND SURVEILLANCE REQUIREMENTS

1/2.1 INSTRUMENTATION

1/2.1.2 RADIOACTIVE GASEOUS EFFLUENT MONITORING INSTRUMENTATION

CONTROLS

- 1.1.2 In accordance with SQN Technical Specification 6.8.4.f.1, the radioactive gaseous effluent monitoring instrumentation channels shown in Table 1.1-2 shall be OPERABLE with their alarm/trip setpoints set to ensure that the limits of ODCM Control 1.2.2.1 are not exceeded. The alarm/trip setpoints of these channels shall be determined in accordance with the methodology and parameters in ODCM Section 7.1.

APPLICABILITY: As shown in Table 1.1-2.

ACTION:

- a. With a radioactive gaseous effluent monitoring instrumentation channel alarm/trip setpoint less conservative than required above, without delay suspend the release of radioactive gaseous effluents monitored by the affected channel, declare the channel inoperable, or change the setpoint so it is acceptably conservative.
- b. With less than the minimum number of radioactive gaseous effluent monitoring instrumentation channels OPERABLE take the ACTION shown in Table 1.1-2. Restore the inoperable instruments to OPERABLE status within 30 days and, if unsuccessful, explain in the next Annual Radioactive Effluent Report, pursuant to ODCM Administrative Control 5.2, why the inoperability could not be corrected within 30 days.
- c. The provisions of Controls 1.0.3 and 1.0.4 are not applicable. Report all deviations in the Annual Radioactive Effluent Release Report.

SURVEILLANCE REQUIREMENTS

- 2.1.2 Each radioactive gaseous effluent monitoring instrumentation channel shall be demonstrated OPERABLE by performance of the CHANNEL CHECK, SOURCE/SENSOR CHECK, CHANNEL CALIBRATION, and CHANNEL FUNCTIONAL TEST operations at the frequencies shown in Table 2.1-2.

Table 1.1-2 RADIOACTIVE GASEOUS EFFLUENT MONITORING INSTRUMENTATION
(Page 1 of 3)

	Instrument	Minimum Channels OPERABLE	Applicability	Action
1.	WASTE GAS DISPOSAL SYSTEM			
a.	Noble Gas Activity Monitor (0-RM-90-118A)	1	***	40
b.	Waste Decay Tanks Effluent Flow Rate Measuring Device (0-FI-77-230)	1	***	41
2.	CONDENSER VACUUM EXHAUST SYSTEM			
a.	Noble Gas Activity Monitor (1,2-RM-90-99,119)	1	***	42
b.	Vent Flow Rate Monitor (1,2-F-2-256,257)	1	****	41
3.	SHIELD BUILDING EXHAUST SYSTEM			
a.	Noble Gas Vent Rate Activity Monitor (1,2-R-90-400 ,Eff)	1**	***	43
b.	Iodine Sampler (1,2-FLT-90-402A or 402B)	1	***	43,44
c.	Particulate Sampler (1,2-FLT-90-402A or 402B)	1	***	43,44
d.	Vent Flow Rate Monitor (1,2-FM-90-400),(1,2-RI-90-400 Monitor Item 029 or 1,2-FI-90-400)	1**	***	41,43
e.	Sampler Flow Rate Monitor (1,2-RI-90-400 Monitor Item 028 or 1,2-FI-90-400A)	1	***	45
f.	Primary Sampling Pumps (1,2-PMP-90-452A or 452B)	1**	***	46
4.	AUXILIARY BUILDING VENTILATION SYSTEM			
a.	Noble Gas Activity Monitor (0-RM-90-101B)	1	*	42
b.	Iodine Sampler (0-FLT-90-101)	1	*	44
c.	Particulate Sampler (0-FLT-90-101)	1	*	44
d.	Vent Flow Rate Monitor 0-F-30-5174A (0-F-30-174)*****	1	*	41
e.	Sampler Flow Rate Monitor (0-FIS-90-101)	1	*	45
5.	SERVICE BUILDING VENTILATION SYSTEM			
a.	Noble Gas Activity Monitor (0-RM-90-132B)	1	*	42
b.	Vent Flow Rate Monitor (0-F-90-5132A)	1	*	41

* At all times.

** Operability of shield building noble gas vent rate activity monitor (Eff) requires primary sample pumps, vent flow rate and "Low Rng" radiation inputs since the high radiation alarm is only on the effluent channel ($\mu\text{Ci/s}$). When the vent flow rate monitor is inoperable only the "Low Rng" radiation monitor is still capable of providing noble gas indication. Its associated malfunction alarm on M-30 will alert Operations to any secondary failures such as loss of sample flow or detector failure. Therefore as long as the "Low Rng" is selected and the malfunction alarm is monitored RE-90-400 can be used to meet ODCM Noble gas and Particulate/Iodine sampler requirements. Mid or High range channels do not have any ODCM requirements. The vent flow rate monitor can be OPERABLE without the noble gas vent rate activity monitor.

*** During exhaust system operation.

**** 1,2-F-2-256 is the low range flow element (0-100 cfm). 1,2 -F-2-257 is a mid (0-1000) cfm flow element which should only be used for abnormal conditions.

*****New UNID will be in effect following completion of DCN D20744.

Table 1.1-2 RADIOACTIVE GASEOUS EFFLUENT MONITORING INSTRUMENTATION
(Page 2 of 3) TABLE NOTATION

- ACTION 40 - With the number of channels OPERABLE less than required by the Minimum Channels OPERABLE requirement, the contents of the tank(s) may be released to the environment provided that prior to initiating the release:
- At least two independent samples of the tank's contents obtained by two technically qualified members of the facility staff are analyzed, and
 - At least two technically qualified members of the Facility Staff independently verify the release rate calculations and;
 - At least two technically qualified members of the Facility Staff independently verify the discharge valve lineup.
- Otherwise, suspend release of radioactive effluents via this pathway.
- ACTION 41 - With the number of channels OPERABLE less than required by the Minimum Channels OPERABLE requirement, effluent releases via this pathway may continue provided the flow rate is estimated at least once per 4 hours.
- ACTION 42 - With the number of channels OPERABLE less than required by the Minimum Channels OPERABLE requirement, effluent releases via this pathway may continue provided grab samples are taken at least once per 12 hours and these samples are analyzed for noble gas activity.
- ACTION 43 - Alarm Window M-5C-29, Vent Flow Rate only Inoperable - With any inoperable vent flow monitor on a discharge pathway where a fan is operating (Purge A, Purge B, ABGTS, or EGTS), effluent release may continue provided: (a) "Low Rng" on RI-90-400 is selected instead of "Eff"; and (b) at least once per 12 hours associated instrument malfunction, M-30-15, is verified not annunciated; and (c) a reading from "Low Rng" on RE-90-400 is obtained at least once per 24 hours. The High Rad alarm on M-30 will not be operable under this alignment. Also Action 41 must be complied with.
- Alarm Window M-30-15, Radiation Monitor Inoperable - With the low range channel inoperable, effluent releases may continue provided grab samples are taken at least once per 12 hours and these samples are analyzed for noble gas activity. Also Action 44 must be complied with.
- ACTION 44 - With the number of channels OPERABLE less than required by the Minimum Channels OPERABLE requirement, effluent releases via the affected pathway may continue provided that within 4 hours after the channel has been declared inoperable samples are continuously collected as required in Table 2.2-2. Also Action 45 must be complied with.
- ACTION 45 - With the number of channels OPERABLE less than required by minimum channels OPERABLE requirement, effluent releases via this pathway may continue provided the sampler flow rate is verified at least once per 4 hours.

Table 1.1-2 RADIOACTIVE GASEOUS EFFLUENT MONITORING INSTRUMENTATION
(Page 3 of 3) TABLE NOTATION

ACTION 46 With the number of channels OPERABLE less than required by minimum channels OPERABLE requirement, effluent releases via this pathway may continue provided (a) RM-90-400 is placed in manual sample flow control per SO-90-2, (b) "Low Rng" on RI-90-400 is selected instead of "Eff", and (c) at least once per 12 hours associated instrument malfunction is verified not annunciated; and (d) a reading from "Low Rng" on RE-90-400 is obtained at least once per 24 hours. The High Rad alarm on M-30 will not be operable under this alignment.

Table 2.1-2 RADIOACTIVE GASEOUS EFFLUENT MONITORING INSTRUMENTATION SURVEILLANCE REQUIREMENTS
(Page 1 of 2)

Instrument	CHANNEL CHECK	SOURCE/ SENSOR CHECK	CHANNEL CALIBRATION	CHANNEL FUNCTIONAL TEST	MODE in Which Surveillance Required
1. WASTE GAS DISPOSAL SYSTEM					
a. Noble Gas Activity Monitor (0-RM-90-118A)	P	P	R(3)	Q(1)	*
b. Flow Rate Monitor (0-FI-77-230)	D	N.A.	R	Q	****
2. CONDENSER VACUUM EXHAUST SYSTEM					
a. Noble Gas Activity Monitor (1,2-RM-90-99,119)	D(5)	M(4)	R(3)	Q(2)	*
b. Vent Flow Rate Monitor (1,2-F-2-256,257)	D	N.A.	R	Q	*
3. SHIELD BUILDING EXHAUST SYSTEM					
a. Noble Gas Vent Rate Activity Monitor (1,2-R-90-400A, Eff)	D	M	R(3)	Q(2)	***
b. Iodine Sampler (1,2-FLT-90-402A or 402B)	W	N.A.	N.A.	N.A.	***
c. Particulate Sampler (1,2-FLT-90-402A or 402B)	W	N.A.	N.A.	N.A.	***
d. Vent Flow Rate Monitor (1,2-FM-90-400 or 1,2-FI-90-400)	D	N.A.	R	Q	***
e. Sampler Flow Rate Monitor (1,2-FI-90-400 or 1,2-FI-90-400A)	D	N.A.	R	Q	***
f. Primary Sample Pumps (1,2-PMP-90-452A, 452B)	W	N.A.	N.A.	N.A.	***
4. AUXILIARY BUILDING VENTILATION SYSTEM					
a. Noble Gas Activity Monitor (0-RM-90-101B)	D	M	R(3)	Q(2)	*
b. Iodine Sampler (0-FLT-90-101)	W	N.A.	N.A.	N.A.	*
c. Particulate Sampler (0-FLT-90-101)	W	N.A.	N.A.	N.A.	*
d. Vent Flow Rate Monitor 0-F-30-5174A (0-F-30-174)*	D	N.A.	R	Q	*
e. Sampler Flow Rate Monitor (0-FIS-90-101)	D	N.A.	R	Q	*
5. SERVICE BUILDING VENTILATION SYSTEM					
a. Noble Gas Activity Monitor (0-RM-90-132B)	D	M	R(3)	Q(2)	*
b. Vent Flow Rate Monitor (0-F-90-5132A)	D	N.A.	R	Q	*

* New UNID will be in effect following completion of DCN D20744.

- Table 2.1-2 RADIOACTIVE GASEOUS EFFLUENT MONITORING INSTRUMENTATION SURVEILLANCE REQUIREMENTS
(Page 2 of 2)
TABLE NOTATION

* At all times.

*** During shield building exhaust system operation.

**** During waste gas releases.

(1) The CHANNEL FUNCTIONAL TEST shall also demonstrate that automatic isolation of this pathway and control room alarm annunciation occurs if any of the following conditions exists:

1. Instrument indicates measured levels above the alarm/trip setpoint.
2. Circuit failure.
3. Downscale failure.

(2) The CHANNEL FUNCTIONAL TEST shall also demonstrate that control room alarm annunciation occurs if any of the following conditions exists:

1. Instrument indicates measured levels above an alarm setpoint.
2. Circuit failure.
3. Downscale failure.

For the auxiliary building ventilation system, at least once every 18 months, the CHANNEL FUNCTIONAL TEST shall also demonstrate automatic isolation of this pathway if the instrument indicates measured levels above the alarm/trip setpoint.

(3) The initial CHANNEL CALIBRATION shall be performed using one or more of the reference standards certified by the National Institute of Standards and Technology (NIST) using standards that have been obtained from suppliers that participate in measurement assurance activities with NIST. These standards shall permit calibrating the system over its intended range of energy and measurement range. For subsequent CHANNEL CALIBRATION, sources that have been related to the initial calibration shall be used.

(4) The SOURCE/SENSOR CHECK for the Condenser Vacuum Exhaust Monitor will be accomplished using an LED sensor check source or a radioactive source.

(5) Applicable only to in-service monitor. Either 99 or 119 monitor will be in service for each unit.

1/2 CONTROLS AND SURVEILLANCE REQUIREMENTS

1/2.2 RADIOACTIVE EFFLUENTS

1/2.2.1 LIQUID EFFLUENTS

1/2.2.1.1 CONCENTRATION

CONTROLS

1.2.1.1 In accordance with SQN Technical Specifications 6.8.4.f.2 and 3, the concentration of radioactive material released through the diffuser piping to UNRESTRICTED AREAS (see Figure 3.1) shall be limited at all times to ten times the concentrations specified in 10 CFR Part 20, Appendix B, Table 2, Column 2 for radionuclides other than dissolved or entrained noble gases. For dissolved or entrained noble gases, the concentration shall be limited to 2×10^{-4} $\mu\text{Ci}/\text{ml}$ total activity.

APPLICABILITY: At all times.

ACTION:

- a. With the concentration of radioactive material released to UNRESTRICTED AREAS exceeding the above limits, immediately, restore the concentration to within the above limits.
- b. If samples or analyses required by Table 2.2-1 are not performed, report these in the next Annual Radioactive Effluent Release Report with an explanation why they were missed and what actions were taken to prevent reoccurrence.
- c. The provisions of Controls 1.0.3 and 1.0.4 are not applicable.

SURVEILLANCE REQUIREMENTS

2.2.1.1.1 Radioactive liquid wastes shall be sampled and analyzed according to the sampling and analysis program of Table 2.2-1.

2.2.1.1.2 The results of the radioactivity analysis shall be used in accordance with the methods in ODCM Section 6.1 to assure that the concentration at the point of release is maintained within the limits stated above.

Table 2.2-1 RADIOACTIVE LIQUID WASTE SAMPLING AND ANALYSIS PROGRAM
(Page 1 of 3)

Liquid Release Type	Sampling Frequency	Minimum Analysis Frequency	Type of Activity Analysis	Lower Limit of Detection (LLD) ($\mu\text{Ci/ml}$) ^a
A. Batch Waste Release Tanks^d 1. Cask Decontamination Tank 2. Laundry Tanks (2) 3. Chemical Drain Tank 4. Monitor Tank	P Each Batch	P Each Batch	Principal Gamma Emitters	5×10^{-7}
	P One Batch/M	M	I-131 Dissolved/ Entrained Gases (Gamma Emitters)	1×10^{-6} 1×10^{-5}
	P Each Batch	M Composite ^b	H-3 Gross Alpha	1×10^{-5} 1×10^{-7}
	P Each Batch	Q Composite ^b	Sr-89, Sr-90 Fe-55	5×10^{-8} 1×10^{-6}
B. Continuous Releases^e 1. Steam Generator Blowdown ^h 2. Turbine Building Sump ^h	D Grab Sample	W Composite ^c	Principal Gamma Emitters ^f	5×10^{-7}
	M Grab Sample	M	I-131 Dissolved/ Entrained Gases (Gamma Emitters)	1×10^{-6} 1×10^{-5}
	D Grab Sample	M Composite ^c	H-3 Gross Alpha	1×10^{-5} 1×10^{-7}
	D Grab Sample	Q Composite ^c	Sr-89, Sr-90 Fe-55	5×10^{-8} 1×10^{-6}
C. Periodic Continuous Releases^{e,h} 1. Non-Reclaimable Waste Tank 2. High Crud Tanks (2) 3. Neutralizer Tank	Continuous ^g	W Composite ^c	Principal Gamma Emitters	5×10^{-7}
	M ^g Grab Sample	M	I-131 Dissolved/ Entrained Gases (Gamma Emitters)	1×10^{-6} 1×10^{-5}
	Continuous ^g	M Composite ^c	H-3 Gross Alpha	1×10^{-5} 1×10^{-7}
	Continuous ^g	Q Composite ^c	Sr-89, Sr-90 Fe-55	5×10^{-8} 1×10^{-6}

Table 2.2-1 RADIOACTIVE LIQUID WASTE SAMPLING AND ANALYSIS PROGRAM
(Page 2 of 3) TABLE NOTATION

- a The LLD is defined for the purpose of these specifications as the smallest concentration of radioactive material in a sample that will yield a net count above system background that will be detected with 95% probability with only a 5% probability of falsely concluding that a blank observation represents a "real" signal.

For a particular measurement system (which may include radiochemical separation):

$$LLD = \frac{4.66s_b}{E V 2.22 \times 10^6 Y \exp(-\lambda \Delta t)}$$

Where:

LLD is the "a priori" lower limit of detection as defined above in microcurie per unit mass or volume,
 s_b is the standard deviation of the background counting rate or of the counting rate of a blank sample as appropriate (as counts per minute),
E is the counting efficiency as counts per disintegration,
V is the sample size in units of mass or volume,
 2.22×10^6 is the number of disintegrations per minute per microcurie,
Y is the fractional radiochemical yield (when applicable),
 λ is the radioactive decay constant for the particular radionuclide, and
 Δt for plant effluents is the elapsed time between midpoint of sample collection and time of counting (midpoint).

It should be recognized that the LLD is defined as an a priori (before the fact) limit representing the capability of a measurement system and not an a posteriori (after the fact) limit for a particular measurement.

- b A composite sample is one in which the quantity of liquid sampled is proportional to the quantity of liquid waste discharged and in which the method of sampling employed results in a specimen which is representative of the liquids released.
- c Prior to analyses, all samples taken for the composite shall be thoroughly mixed in order for the composite sample to be representative of the effluent release.

Table 2.2-1 RADIOACTIVE LIQUID WASTE SAMPLING AND ANALYSIS PROGRAM
(Page 3 of 3) TABLE NOTATION

- d A batch release is the discharge of liquid wastes of a discrete volume. Prior to sampling for analyses, each batch shall be isolated, and then thoroughly mixed, by the method described in ODCM Section 6.1.1, to assure representative sampling.
- e A continuous release is the discharge of liquid wastes of a nondiscrete volume; e.g., from a volume or system that has an input flow during the continuous release.
- f The principal gamma emitters for which the LLD specification applies exclusively are the following radionuclides: Mn-54, Fe-59, Co-58, Co-60, Zn-65, Mo-99, Cs-134, Cs-137, and Ce-141. Ce-144 shall also be measured with an LLD of 5×10^{-6} . This list does not mean that only these nuclides are to be detected and reported. Other peaks which are measurable and identifiable, together with the above nuclides, shall also be identified and reported.
- g Releases from these tanks are continuously composited during releases. With the composite sampler or the sampler flow monitor inoperable, the sampling frequency shall be changed to require representative batch samples from each tank to be released to be taken prior to release and manually composited for these analyses.
- h Applicable only during periods of primary to secondary leakage or the release of radioactivity as detected by the effluent radiation monitor provided the radiation monitor setpoint is set to alarm if activity in the stream exceeds a routine normal background, or compensatory requirements associated with applicable inoperable monitors are met.

1/2 CONTROLS AND SURVEILLANCE REQUIREMENTS

1/2.2 RADIOACTIVE EFFLUENTS

1/2.2.1 LIQUID EFFLUENTS

1/2.2.1.2 DOSE

CONTROLS

1.2.1.2 In accordance with SQN Technical Specification 6.8.4.f.4 and 5, the dose or dose commitment to a member of the public from radioactive materials in liquid effluents released to UNRESTRICTED AREAS shall be limited from each reactor unit:

- a. During any calendar quarter to less than or equal to 1.5 mrem to the total body and to less than or equal to 5 mrem to any organ, and
- b. During any calendar year to less than or equal to 3 mrem to the total body and to less than or equal to 10 mrem to any organ.

APPLICABILITY: At all times.

ACTION:

- a. With the calculated dose from the release of radioactive materials in liquid effluents exceeding any of the above limits, prepare and submit to the Commission within 30 days, pursuant to ODCM Administrative Control 5.4, a Special Report which identifies the cause(s) for exceeding the limit(s) and defines the corrective actions that have been taken to reduce the releases and the proposed corrective actions to be taken to assure that subsequent releases will be in compliance with the above limits. This Special Report shall also include (1) the results of radiological analyses of the drinking water source and (2) the radiological impact on finished drinking water supplies with regard to the requirements of 40 CFR 141 (applicable only if drinking water supply is taken from the receiving water body within three miles downstream of the plant discharge).
- b. The provisions of Controls 1.0.3 and 1.0.4 are not applicable.

SURVEILLANCE REQUIREMENTS

2.2.1.2 Cumulative dose contributions from liquid effluents for the current calendar quarter and current calendar year shall be determined in accordance with the methodology and parameters in ODCM Section 6.3 at least once per 31 days.

1/2 CONTROLS AND SURVEILLANCE REQUIREMENTS

1/2.2 RADIOACTIVE EFFLUENTS

1/2.2.1 LIQUID EFFLUENTS

1/2.2.1.3 LIQUID RADWASTE TREATMENT SYSTEM

CONTROLS

1.2.1.3 In accordance with SQN Technical Specification 6.8.4.f.6, the liquid radwaste treatment system shall be used to reduce the radioactive materials in liquid wastes prior to their discharge when the projected doses due to the liquid effluent to UNRESTRICTED AREAS (see Figure 3.1) would exceed 0.06 mrem per reactor unit to the total body or 0.2 mrem per reactor unit to any organ in a 31-day period.

APPLICABILITY: At all times.

ACTION:

- a. With radioactive liquid waste being discharged without treatment and in excess of the above limits, prepare and submit to the Nuclear Regulatory Commission within 30 days pursuant to ODCM Administrative Control 5.4, a Special Report which includes the following information:
 1. Identification of the inoperable equipment or subsystems and the reason for inoperability,
 2. Action(s) taken to restore the inoperable equipment to OPERABLE status, and
 3. Summary description of action(s) taken to prevent a recurrence.
- b. The provisions of Controls 1.0.3 and 1.0.4 are not applicable.

SURVEILLANCE REQUIREMENTS

2.2.1.3 Doses due to liquid releases from each unit to UNRESTRICTED AREAS shall be projected at least once per 31 days, in accordance with the methodology and parameters in ODCM Section 6.5.

1/2 CONTROLS AND SURVEILLANCE REQUIREMENTS

1/2.2 RADIOACTIVE EFFLUENTS

1/2.2.2 GASEOUS EFFLUENTS

1/2.2.2.1 DOSE RATE

CONTROLS

1.2.2.1 In accordance with SQN Technical Specification 6.8.4.f.7, the dose rate at any time due to radioactive materials released in gaseous effluents to areas at or beyond the UNRESTRICTED AREA BOUNDARY (see Figure 3.1) shall be in accordance with the following:

- a. For noble gases: Less than or equal to a dose rate of 500 mrem/yr to the whole body and less than or equal to a dose rate of 3000 mrem/yr to the skin, and
- b. For Iodine-131, Iodine-133, tritium, and for all radionuclides in particulate form with half-lives greater than 8 days: Less than or equal to a dose rate of 1500 mrem/yr to any organ.

APPLICABILITY: At all times.

ACTION:

- a. With dose rate(s) exceeding the above limits, without delay restore the release rate to within the above limit(s).
- b. If samples or analyses required by Table 2.2-2 are not performed, report these in the next Annual Radioactive Effluent Release Report with an explanation why they were missed and what actions were taken to prevent reoccurrence.
- c. The provisions of Controls 1.0.3 and 1.0.4 are not applicable.

SURVEILLANCE REQUIREMENTS

2.2.2.1.1 The dose rate due to noble gases in gaseous effluents shall be determined to be within the above limits in accordance with the methodology and parameters in ODCM Section 7.2.3, and

2.2.2.1.2 The dose rate due to Iodine-131, Iodine-133, tritium, and for all radionuclides in particulate form with half-lives greater than 8 days in gaseous effluents shall be determined to be within the above limits in accordance with the methodology and parameters in ODCM Section 7.2.4 and by obtaining representative samples and performing analyses in accordance with the sampling and analysis program specified in Table 2.2-2.

Table 2.2-2 RADIOACTIVE GASEOUS WASTE MONITORING SAMPLING AND ANALYSIS PROGRAM
(Page 1 of 3)

Gaseous Release Type	Sampling Frequency	Minimum Analysis Frequency	Type of Activity Analysis	Lower Limit of Detection (LLD) ($\mu\text{Ci/ml}$) ^a
A. Waste Gas Storage Tank	P Each Tank Grab	P Each Tank	Principal Gamma Emitters ⁹	1×10^{-4}
B. Containment				
1. PURGE	P ⁱ Each PURGE Grab Sample	P ⁱ Each PURGE	Principal Gamma Emitters ⁹ H-3	1×10^{-4} 1×10^{-6}
2. Vent	W ^j Grab Sample	W ^j	Principal Gamma Emitters ⁹ H-3	1×10^{-4} 1×10^{-6}
C. Noble Gases and Tritium	M Grab Sample	M	Principal Gamma Emitters ⁹ H-3	1×10^{-4} 1×10^{-6}
1. Condenser Vacuum Exhaust ^h				
2. Auxiliary Building Exhaust ^{b,e}				
3. Service Bldg. Exhaust				
4. Shield Bldg. Exhaust ^{b,c,h}				
D. Iodine and Particulates				
1. Auxiliary Building Exhaust	Continuous Sampler ^f	W ^d Charcoal Sample	I-131	1×10^{-12}
2. Shield Building Exhaust ^h	Continuous Sampler ^f	W ^d Particulate Sample	Principle Gamma Emitters ⁹ (I-131, Others)	1×10^{-11}
	Continuous Sampler	M Composite Particulate Sampler	Gross Alpha	1×10^{-11}
	Continuous Sampler ^f	Q Composite Particulate Sample	Sr-89, Sr-90	1×10^{-11}
E. Noble Gases All Release types as listed in C	Continuous Monitor ^f	Noble Gas Monitor	Noble Gases Gross Beta or Gamma	1×10^{-6}

Table 2.2-2 (Page 2 of 3)
RADIOACTIVE GASEOUS WASTE MONITORING SAMPLING AND ANALYSIS PROGRAM
TABLE NOTATION

- a The LLD is defined, for the purpose of these Controls, as the smallest concentration of radioactive material in a sample that will yield a net count above system background that will be detected with 95% probability with only a 5% probability of falsely concluding that a blank observation represents a "real" signal.

For a particular measurement system (which may include radiochemical separation):

$$LLD = \frac{4.66s_b}{E V 2.22 \times 10^6 Y \exp(-\lambda \Delta t)}$$

Where:

LLD is the "a priori" lower limit of detection as defined above in microcurie per unit mass or volume,
 s_b is the standard deviation of the background counting rate or of the counting rate of a blank sample as appropriate (as counts per minute),
E is the counting efficiency as counts per disintegration,
V is the sample size in units of mass or volume,
 2.22×10^6 is the number of disintegrations per minute per microcurie,
Y is the fractional radiochemical yield (when applicable),
 λ is the radioactive decay constant for the particular radionuclide, and
 Δt is the elapsed time between midpoint of sample collection and time of counting (midpoint) in minutes.

It should be noted that the LLD is defined as an a priori (before the fact) limit representing the capability of a measurement system and not an a posteriori (after the fact) limit for a particular measurement.

- b Sampling and analysis shall also be performed following shutdown, startup, or a thermal power change exceeding 15% of RATED THERMAL POWER within 1 hour unless (1) analysis shows that the DOSE EQUIVALENT I-131 concentration in the primary coolant has not increased more than a factor of 3 and (2) the containment noble gas activity monitor (RE-90-106 or RE-90-112) shows that the radioactivity has not increased by more than a factor of 3.
- c Tritium grab samples shall be taken periodically when the refueling canal is flooded.

Table 2.2-2 - RADIOACTIVE GASEOUS WASTE MONITORING SAMPLING AND ANALYSIS PROGRAM
TABLE NOTATION
(Page 3 of 3)

- d Samples shall be changed at least once per 7 days. Sampling shall also be performed at least once per 24 hours for at least 2 days following each shutdown from $\geq 15\%$ RATED THERMAL POWER, startup of $\geq 15\%$ RATED THERMAL POWER or THERMAL POWER change exceeding 15% of RATED THERMAL POWER in one hour. Only one set of samples will be required in a 24-hour period. When samples collected for ≤ 24 hours are analyzed, the corresponding LLD's may be increased by a factor of 10.
- e Tritium grab samples shall be taken periodically from the ventilation exhaust from the spent fuel pool area, whenever spent fuel is in the spent fuel pool.
- f The ratio of the sample flow rate to the sampled stream flow rate shall be known for the time period covered by each dose or dose rate calculation made in accordance with ODCM Sections 7.2, 7.3, and 7.4.
- g The principal gamma emitters for which the LLD specification applies exclusively are the following radionuclides: Kr-87, Kr-88, Xe-133, Xe-133m, Xe-135, and Xe-138 for noble gases and Mn-54, Fe-59, I-131, Co-58, Co-60, Zn-65, Mo-99, Cs-134, Cs-137, Ce-141 and Ce-144 for particulate principal gamma emitters. This list does not mean that only these nuclides are to be detected and reported. Other gamma peaks which are measurable and identifiable, together with the above nuclides, shall also be analyzed and reported in the Annual Radioactive Effluent Release Report pursuant to ODCM Administrative Control 5.2.
- h During releases via this exhaust system.
- i PURGING - Applicable in MODES 1, 2, 3 and 4, the upper and lower compartments of the containment shall be sampled prior to PURGING. Prior to breaking containment integrity in MODE 5 or 6, the upper and lower compartments of the containment shall be sampled. The incore instrument room purge sample shall be obtained at the shield building exhaust between 20 and 25 minutes following initiation of the incore instrument room PURGE or at the peak of the discharge based on the radiation monitor response.
- j VENTING - Applicable in MODES 1, 2, 3, and 4; the containment will be VENTED to the containment annulus and then to the auxiliary building via containment annulus fans. The lower containment compartment shall be sampled weekly and the lower containment radiation monitor response will be recorded daily when VENTING is to occur to account for the radioactivity being discharged from the VENTING process. The lower containment will be re-sampled when the reading on the lower containment radiation monitor (RE-90-106 or 112), increases by 50% from the initial value. If the lower containment noble gas monitor (RE-90-106 or 112) is inoperable, noble gas grab samples may be used to perform this comparison.

1/2 CONTROLS AND SURVEILLANCE REQUIREMENTS

1/2.2 RADIOACTIVE EFFLUENTS

1/2.2.2 GASEOUS EFFLUENTS

1/2.2.2.2 DOSE - NOBLE GASES

CONTROLS

1.2.2.2 In accordance with SQN Technical Specification 6.8.4.f.8, the air dose due to noble gases released in gaseous effluents from each reactor unit to areas at or beyond the UNRESTRICTED AREA BOUNDARY (see Figure 3.1) shall be limited to the following:

- a. During any calendar quarter: Less than or equal to 5 mrad for gamma radiation and less than or equal to 10 mrad for beta radiation and
- b. During any calendar year: Less than or equal to 10 mrad for gamma radiation and less than or equal to 20 mrad for beta radiation.

APPLICABILITY: At all times.

ACTION:

- a. With the calculated air dose from radioactive noble gases in gaseous effluents exceeding any of the above limits, prepare and submit to the Nuclear Regulatory Commission within 30 days, pursuant to ODCM Administrative Control 5.4, a Special Report which identifies the cause(s) for exceeding the limit(s) and defines the corrective actions that have been taken to reduce the releases and the proposed corrective actions to be taken to assure that subsequent releases will be in compliance with the above limits.
- b. The provisions of Controls 1.0.3 and 1.0.4 are not applicable.

SURVEILLANCE REQUIREMENTS

2.2.2.2 Cumulative dose contributions for the current calendar quarter and current calendar year for noble gases shall be determined in accordance with the methodology and parameters in ODCM Section 7.3 at least once per 31 days.

1/2 CONTROLS AND SURVEILLANCE REQUIREMENTS

1/2.2 RADIOACTIVE EFFLUENTS

1/2.2.2 GASEOUS EFFLUENTS

1/2.2.2.3 DOSE - I-131, I-133, TRITIUM AND RADIONUCLIDES IN PARTICULATE FORM WITH HALF-LIVES GREATER THAN EIGHT DAYS

CONTROLS

1.2.2.3 In accordance with SQN Technical Specification 6.8.4.f.9, the dose to a member of the public from I-131, I-133, tritium and all radionuclides in particulate form with half-lives greater than 8 days in gaseous effluents released to areas at or beyond the UNRESTRICTED AREA BOUNDARY (see Figure 3.1) shall be limited to the following from each reactor unit:

- a. During any calendar quarter: Less than or equal to 7.5 mrem to any organ and,
- b. During any calendar year: Less than or equal to 15 mrem to any organ.

APPLICABILITY: At all times.

ACTION:

- a. With the calculated dose from the release of I-131, I-133, tritium and all radionuclides in particulate form with half-lives greater than 8 days, in gaseous effluents exceeding any of the above limits, prepare and submit to the Nuclear Regulatory Commission within 30 days, pursuant to ODCM Administrative Control 5.4, a Special Report which identifies the cause(s) for exceeding the limit(s) and defines the corrective actions that have been taken to reduce the releases and the proposed corrective actions to be taken to assure that subsequent releases will be in compliance with the above limits.
- b. The provisions of Controls 1.0.3 and 1.0.4 are not applicable.

SURVEILLANCE REQUIREMENTS

2.2.2.3 Cumulative dose contributions for the current calendar quarter and current calendar year for I-131, I-133, tritium and all radionuclides in particulate form with half-lives greater than 8 days shall be determined in accordance with the methodology and parameters in ODCM Section 7.4 at least once per 31 days.

1/2 CONTROLS AND SURVEILLANCE REQUIREMENTS

1/2.2 RADIOACTIVE EFFLUENTS

1/2.2.2 GASEOUS EFFLUENTS

1/2.2.2.4 GASEOUS RADWASTE TREATMENT

CONTROLS

1.2.2.4 In accordance with SQN Technical Specification 6.8.4.f.5 and 6, the GASEOUS RADWASTE TREATMENT SYSTEM and the VENTILATION EXHAUST TREATMENT SYSTEM shall be used to reduce radioactive materials in gaseous waste prior to their discharge when the projected gaseous effluent doses due to gaseous effluent releases to areas at or beyond the SITE BOUNDARY (see Figure 3.1), when averaged over 31 days, would exceed 0.2 mrad per unit for gamma radiation, and 0.4 mrad per unit for beta radiation. The appropriate portions of the VENTILATION EXHAUST TREATMENT SYSTEM shall be used to reduce radioactive materials in gaseous waste prior to their discharge when the projected doses due to gaseous effluents to areas at or beyond the UNRESTRICTED AREA BOUNDARY (See Figure 3.1) when averaged over 31 days would exceed 0.3 mrem per unit to any organ.

ACTION:

- a. With the radioactive gaseous waste being discharged without treatment for more than 31 days and in excess of the above limits, prepare and submit to the Commission within 30 days, pursuant to ODCM Administrative Control 5.4, a Special Report which includes the following information:
 1. Identification of the inoperable equipment or subsystems and the reason for inoperability.
 2. Action(s) taken to restore the inoperable equipment to OPERABLE status.
 3. Summary description of action(s) taken to prevent a recurrence.
- b. The provisions of Controls 1.0.3 and 1.0.4 are not applicable.

SURVEILLANCE REQUIREMENTS

2.2.2.4 Doses due to gaseous releases from the site shall be projected at least once per 31 days, in accordance with the methodology and parameters in ODCM Section 7.5.

1/2 CONTROLS AND SURVEILLANCE REQUIREMENTS

1/2.2 RADIOACTIVE EFFLUENTS

1/2.2.3 TOTAL DOSE

CONTROLS

1.2.3 In accordance with SQN Technical Specification 6.8.4.f.10, the annual (calendar year) dose or dose commitment to any member of the public, beyond the site boundary due to releases of radioactivity from uranium fuel cycle sources, shall be limited to less than or equal to 25 mrem to the total body or any organ (except the thyroid, which shall be limited to less than or equal to 75 mrem).

APPLICABILITY: At all times.

ACTION:

- a. With the calculated doses from the release of radioactive materials in liquid or gaseous effluents exceeding twice the limits of ODCM Control 1.2.1.2, 1.2.2.2, or 1.2.2.3, calculations should be made to determine whether the above limits have been violated. If such is the case, prepare and submit a Special Report to the Director, Nuclear Reactor Regulation, U.S. Nuclear Regulatory Commission, Washington D.C. 20555, within 30 days, which defines the corrective action to be taken to reduce subsequent releases to prevent recurrence of exceeding the limits above. This Special Report, as defined in 10 CFR Part 20.2203, shall include an analysis which estimates the radiation dose to a member of the public beyond the site boundary from uranium fuel cycle sources (including all effluent pathways and direct radiation) for a calendar year that includes the release(s) covered by this report. If the estimated dose(s) exceeds the above limits, and if the release condition resulting in violation of 40 CFR Part 190 has not already been corrected, the Special Report shall include a request for a variance in accordance with the provisions of 40 CFR Part 190 and include the specified information of Section 190.11(b). Submittal of the report is considered a timely request, and a variance is granted until the staff action on the request is complete.
- b. The provisions of Controls 1.0.3 and 1.0.4 are not applicable.

SURVEILLANCE REQUIREMENTS

2.2.3 Cumulative dose contributions from liquid and gaseous effluents shall be determined in accordance with the methodology and parameters in ODCM Sections 6.3, 7.3, and 7.4.

1/2 CONTROLS AND SURVEILLANCE REQUIREMENTS

1/2.3 RADIOLOGICAL ENVIRONMENTAL MONITORING

1/2.3.1 MONITORING PROGRAM

CONTROLS

1.3.1 The radiological environmental monitoring program shall be conducted as specified in Table 2.3-1.

APPLICABILITY: At all times.

ACTION:

- a. With the radiological environmental monitoring program not being conducted as specified in Table 2.3-1, prepare and submit to the Commission, in the Annual Radiological Environmental Operating Report, a description of the reasons for not conducting the program as required and the plans for preventing a recurrence.
- b. With the level of radioactivity in an environmental sampling medium exceeding the reporting levels of Table 2.3-2 when averaged over any calendar quarter, prepare and submit to the Commission within 30 days from the end of the affected quarter, pursuant to ODCM Administrative Control 5.4, a Special Report that identifies the cause(s) for exceeding the limit(s) and defines the corrective actions to be taken to reduce radioactive effluents so that the potential annual dose to a member of the public is less than the calendar year limits of ODCM Controls 1.2.1.2, 1.2.2.2 and 1.2.2.3. When one or more of the radionuclides in Table 2.3-2 is detected in the sampling medium, this report shall be submitted if:

$$\frac{\text{concentration}(1)}{\text{limit level}(1)} + \frac{\text{concentration}(2)}{\text{limit level}(2)} + \dots \geq 1.0$$

When radionuclides other than those in Table 2.3-2 are detected and are the result of plant effluents, this report shall be submitted if the potential annual dose to a member of the public from all radionuclides is equal to or greater than the calendar year limits of ODCM Controls 1.2.1.2, 1.2.2.2, and 1.2.2.3. This report is not required if the measured level of radioactivity was not the result of plant effluents; however, in such an event, the condition shall be reported and described in the Annual Radiological Environmental Operating Report.

1/2 CONTROLS AND SURVEILLANCE REQUIREMENTS

1/2.3 RADIOLOGICAL ENVIRONMENTAL MONITORING

1/2.3.1 MONITORING PROGRAM

ACTION (CONTINUED):

- c. With milk or fresh leafy vegetable samples unavailable from one or more of the sample locations required by Table 2.3-1, identify locations for obtaining replacement samples and add them to the radiological environmental monitoring program within 30 days. The specified locations from which samples were unavailable may then be deleted from the monitoring program. Pursuant to ODCM Administrative Control 5.1, identify the new locations for obtaining replacement samples in the Annual Radiological Environmental Operating Report. A revised figure(s) and table(s) for the ODCM reflecting the new location(s) shall be included in the next Annual Effluent Release Report pursuant to ODCM Administrative Control 5.2.
- d. The provisions of Controls 1.0.3 and 1.0.4 are not applicable.

SURVEILLANCE REQUIREMENTS

- 2.3.1 The radiological environmental monitoring samples shall be collected pursuant to Table 2.3-1 from the locations given in the tables and figures given in ODCM Section 9.0 and shall be analyzed pursuant to the requirements of Table 2.3-1 and the detection capabilities required by Table 2.3-3.

Table 2.3-1 MINIMUM REQUIRED RADIOLOGICAL ENVIRONMENTAL MONITORING PROGRAM
(Page 1 of 2)

Exposure Pathway and/or Sample	Number and Location of Samples*	Sampling and Collection Frequency	Type and Frequency of Analysis
AIRBORNE			
Radioiodine and Particulates	Minimum of 5 locations	W Continuous sampler**	Radioiodine canister: Weekly I-131 Particulate sampler: Analyze for gross beta activity \geq 24 hours following filter change. Perform gamma isotopic analysis on each sample when gross beta activity is > 10 times the yearly mean of control samples Q: Perform gamma isotopic analysis on composite (by location) sample.
DIRECT RADIATION			
	35 to 40 locations with \geq 2 dosimeters for continuously measuring and recording dose rate at each location.	Q	Q: Gamma Dose
WATERBORNE			
Surface	2 locations	M Composite*** sample	Gamma isotopic Each composite sample Tritium analysis
Ground	2 locations	Q	Gamma isotopic and tritium analyses of each sample. Gross beta and gamma isotopic analysis
Drinking	Minimum of 1 location	M Composite*** sample	Q Tritium analysis
	2 locations	M Grab sample	Gross beta and gamma isotopic analysis
Shoreline Sediment locations	Minimum of 2 locations	S	Gamma isotopic analysis from each sample.

*Sample locations are given in Table 9.1.

**Continuous sampling with sample collection as required by dust loading, but at least once per 7 days.

***Composite samples shall be collected by collecting an aliquot at intervals not exceeding 2 hours.

Table 2.3-1 MINIMUM REQUIRED RADIOLOGICAL ENVIRONMENTAL MONITORING PROGRAM
(Page 2 of 2)

Exposure Pathway and/or Sample	Number and Location of Samples*	Sampling and Collection Frequency	Type and Frequency of Analysis
INGESTION			
Milk	Milk from 3 locations. Samples of broad leaf vegetation at offsite locations of highest D/Q if no milk samples are available.	B****	Gamma isotopic and I-131 analysis of each sample.
Fish	2 locations	One sample in season, or at least once per 184 days if not seasonal. One sample representing a commercially important species and one sample representing a recreationally important species.	Gamma isotopic analysis on edible portions.
Food Products	Minimum of 2 locations	At time of harvest. One sample of each of the following or similar classes of food products, as available 1. Lettuce and/or cabbage 2. Corn 3. Beans 4. Tomatoes	Gamma isotopic analysis on edible portions.

**** When animals are on pasture, at least once per 31 days at other times.

Table 2.3-2 REPORTING LEVELS FOR RADIOACTIVITY CONCENTRATIONS IN ENVIRONMENTAL SAMPLES

Analysis	Water (pCi/L)	Airborne Particulate or gases (pCi/m ³)	Fish (pCi/kg, wet)	Milk (pCi/L)	Food Products (pCi/kg, wet)
H-3	2 x 10 ⁴ (a)	N.A.	N.A.	N.A.	N.A.
Mn-54	1 x 10 ³	N.A.	3 x 10 ⁴	N.A.	N.A.
Fe-59	4 x 10 ²	N.A.	1 x 10 ⁴	N.A.	N.A.
Co-58	1 x 10 ³	N.A.	3 x 10 ⁴	N.A.	N.A.
Co-60	3 x 10 ²	N.A.	1 x 10 ⁴	N.A.	N.A.
Zn-65	3 x 10 ²	N.A.	2 x 10 ⁴	N.A.	N.A.
Zr-Nb-95	4 x 10 ²	N.A.	N.A.	N.A.	N.A.
I-131	2 ^(b)	0.9	N.A.	3	1x10 ²
Cs-134	30	10	1x10 ³	60	1x10 ³
Cs-137	50	20	2x10 ³	70	2x10 ³
Ba-La-140	2 x 10 ²	N.A.	N.A.	3 x 10 ²	N.A.

(a) For drinking water samples. This is 40 CFR Part 141 value. If no drinking water pathway exists, a value of 30,000 pCi/L may be used.

(b) If no drinking water pathway exists, a value of 20 pCi/L may be used.

Table 2.3-3 MAXIMUM VALUES FOR THE LOWER LIMITS OF DETECTION (LLD)^{a,b}
(Page 1 of 2)

Analysis	Water (pCi/L)	Airborne Particulate or Gases (pCi/m ³)	Fish (pCi/kg, wet)	Milk (pCi/L)	Food Products (pCi/kg,wet)	Sediment (pCi/kg,dry)
gross beta	4	1x10 ⁻²	N.A.	N.A.	N.A.	N.A.
H-3	2000*	N.A.	N.A.	N.A.	N.A.	N.A.
Mn-54	15	N.A.	130	N.A.	N.A.	N.A.
Fe-59	30	N.A.	260	N.A.	N.A.	N.A.
Co-58,60	15	N.A.	130	N.A.	N.A.	N.A.
Zn-65	30	N.A.	260	N.A.	N.A.	N.A.
Zr-95	30	N.A.	N.A.	N.A.	N.A.	N.A.
Nb-95	15	N.A.	N.A.	N.A.	N.A.	N.A.
I-131	1**	7x10 ⁻²	N.A.	1	60	N.A.
Cs-134	15	5x10 ⁻²	130	15	60	150
Cs-137	18	6x10 ⁻²	150	18	80	180
Ba-140	60	N.A.	N.A.	60	N.A.	N.A.
La-140	15	N.A.	N.A.	15	N.A.	N.A.

* If no drinking water pathway exists, a value of 3000 pCi/L may be used.

** If no drinking water pathway exists, a value of 15 pCi/L may be used.

Table 2.3-3 MAXIMUM VALUES FOR THE LOWER LIMITS OF DETECTION (LLD)^{a,b}
(Page 2 of 2) TABLE NOTATION

- a The LLD is defined, for the purpose of these Controls, as the smallest concentration of radioactive material in a sample that will yield a net count above system background that will be detected with 95% probability with only a 5% probability of falsely concluding that a blank observation represents a "real" signal.

For a particular measurement system (which may include radiochemical separation):

$$LLD = \frac{4.66s_b}{E V 2.22 Y \exp(-\lambda\Delta t)}$$

where:

LLD is the "a priori" lower limit of detection as defined above in picocurie per unit mass or volume,
 s_b is the standard deviation of the background counting rate or of the counting rate of a blank sample as appropriate (as counts per minute),

E is the counting efficiency as counts per disintegration,

V is the sample size in units of mass or volume,

2.22 is the number of disintegrations per minute per picocurie,

Y is the fractional radiochemical yield (when applicable),

λ is the radioactive decay constant for the particular radionuclide, and

Δt for environmental samples is the elapsed time between sample collection (or end of the sample collection period) and time of counting.

It should be recognized that the LLD is defined as an a priori (before the fact) limit representing the capability of a measurement system and not an a posteriori (after the fact) limit for a particular measurement. Analysis will be performed in such a manner that the stated LLDs will be achieved under routine conditions.

- b Other peaks which are measurable and identifiable, together with the radionuclides above, shall be identified and reported.

1/2 CONTROLS AND SURVEILLANCE REQUIREMENTS

1/2.3 RADIOLOGICAL ENVIRONMENTAL MONITORING

1/2.3.2 LAND USE CENSUS

CONTROLS

1.3.2 A Land Use Census shall be conducted and shall identify within a distance of 8 km (5 miles) the location in each of the 16 meteorological sectors of the nearest milk animal, the nearest residence, and the nearest garden^a of greater than 50 m² (500 ft²) producing fresh leafy vegetables.

^aBroad leaf vegetation sampling of at least three different kinds of vegetation may be performed at the site boundary in each of two different direction sectors with the highest predicted D/Qs in lieu of the garden census. Specifications for broad leaf vegetation sampling in Table 2.3-1 shall be followed, including analysis of control samples.

APPLICABILITY: At all times.

ACTION:

- a. With a Land Use Census identifying a location(s) that yields a calculated dose or dose commitment 20% greater than at a location from which doses are currently being calculated in ODCM Section 7.3 and 7.4 identify the new location(s) in the next Annual Radioactive Effluent Release Report pursuant to ODCM Administrative Control 5.2.
- b. With a Land Use Census identifying a location(s) that yields a calculated dose or dose commitment (via the same pathway) 20% greater than at a location from which samples are currently being obtained in accordance with the requirements of ODCM Control 1.3.1, add the new location(s) within 30 days to the radiological environmental monitoring program given in ODCM Section 9.0, if samples are available. The sampling location(s), excluding the control station location, having the lowest calculated dose or dose commitment(s), via the same exposure pathway, may be deleted from this monitoring program after October 31 of the year in which this Land Use Census was conducted. Pursuant to ODCM Administrative Controls 5.2 and 5.3, submit in the next Annual Radioactive Effluent Release Report documentation for a change in the ODCM including a revised figure(s) and table(s) for the ODCM reflecting the new location(s) with the information supporting the change in sampling locations.
- c. The provisions of Controls 1.0.3 and 1.0.4 are not applicable:

1/2 CONTROLS AND SURVEILLANCE REQUIREMENTS

1/2.3 RADIOLOGICAL ENVIRONMENTAL MONITORING

1/2.3.2 LAND USE CENSUS

SURVEILLANCE REQUIREMENTS

- 2.3.2 The Land Use Census shall be conducted during the growing season at least once per 12 months using that information that will provide the best results, such as by a door-to-door survey, mail survey, telephone survey, aerial survey, or by consulting local agricultural authorities. The results of the Land Use Census shall be included in the Annual Radiological Environmental Operating Report pursuant to ODCM Administrative Control 5.1.

1/2 CONTROLS AND SURVEILLANCE REQUIREMENTS

1/2.3 RADIOLOGICAL ENVIRONMENTAL MONITORING

1/2.3.3 INTERLABORATORY COMPARISON PROGRAM

CONTROLS

1.3.3 Analyses shall be performed on radioactive materials supplied as part of an Interlaboratory Comparison Program which has been approved by the Commission.

APPLICABILITY: At all times.

ACTION:

- a. With analyses not being performed as required above, report the corrective actions being taken to prevent a recurrence to the Commission in the Annual Radiological Environmental Operating Report pursuant to ODCM Administrative Control 5.1.
- b. The provisions of Controls 1.0.3 and 1.0.4 are not applicable.

SURVEILLANCE REQUIREMENTS

2.3.3 A summary of the results obtained as a part of the above required Interlaboratory Comparison Program and in accordance with the guidance below shall be included in the Annual Radiological Environmental Operating Report pursuant to ODCM Administrative Control 5.1.

BASES FOR
SECTIONS 1.0 AND 2.0
CONTROLS
AND
SURVEILLANCE REQUIREMENTS

NOTE

The BASES contained in succeeding pages summarize the reasons for the Controls in Sections 1.0 and 2.0, but are not part of these Controls.

BASES

INSTRUMENTATION

1/2.1.1 RADIOACTIVE LIQUID EFFLUENT MONITORING INSTRUMENTATION

The radioactive liquid effluent instrumentation is provided to monitor and control, as applicable, the releases of radioactive materials in liquid effluents during actual or potential releases of liquid effluents. The alarm/trip setpoints for these instruments shall be calculated in accordance with the procedures in ODCM Section 6.2 to ensure that the alarm/trip will occur prior to exceeding ten times the limits of 10 CFR Part 20. The OPERABILITY and use of this instrumentation is consistent with the requirements of General Design Criteria 60, 63, and 64 of Appendix A to 10 CFR Part 50.

1/2.1.2 RADIOACTIVE GASEOUS EFFLUENT MONITORING INSTRUMENTATION

The radioactive gaseous effluent instrumentation is provided to monitor and control, as applicable, the releases of radioactive materials in gaseous effluents during actual or potential releases of gaseous effluents. The alarm/trip setpoints for these instruments shall be calculated in accordance with the procedures in ODCM Section 7.1 to ensure that the alarm/trip will occur prior to exceeding ten times the limits of 10 CFR Part 20. The OPERABILITY and use of this instrumentation is consistent with the requirements of General Design Criteria 60, 63, and 64 of Appendix A to 10 CFR Part 50.

1/2.2 RADIOACTIVE EFFLUENTS

1/2.2.1.1 CONCENTRATION

This Control is provided to ensure that the concentration of radioactive materials released at any time in liquid waste effluents to UNRESTRICTED AREAS will be less than ten times the concentration levels specified in 10 CFR Part 20, Appendix B, Table 2, Column 2. This limitation provides additional assurance that the levels of radioactive materials in bodies of water in UNRESTRICTED AREAS will result in exposures within (1) the Section II.A design objectives of Appendix I, 10 CFR 50, and (2) the limits of 10 CFR 20.1301(a)(1) to a member of the public. The concentration limit for dissolved or entrained noble gases is based upon the assumption that Xe-135 is the controlling radioisotope and its MPC in air (submersion) was converted to an equivalent concentration in water using the methods described in International Commission of Radiological Protection (ICRP) Publication 2.

1/2.2.1.2 DOSE

This Control is provided to implement the requirements of Sections II.A, III.A, and IV.A of Appendix I, 10 CFR Part 50. The requirement implements the guide set forth in Section II.A of Appendix I. The action statements provide the required operating flexibility and at the same time implement the guides set forth in Section IV.A of Appendix I to assure that the releases of radioactive materials in liquid effluents will be kept "as low as reasonable achievable." Also, for fresh water sites with drinking water supplies which can be potentially affected by plant operations, there is reasonable assurance that the operation of the facility will not result in radionuclide concentrations in the finished drinking water that are in excess of the requirements of 40 CFR Part 141. The dose calculations in ODCM Section 6.3 implement the requirements in Section III.A of Appendix I that conformance with the guides of Appendix I be shown by calculational procedures based on models and data, such that the actual exposure of a member of the public through appropriately modeled pathways is unlikely to substantially underestimated. The equations specified in Section 6.3 for calculating the doses due to the actual release rates of radioactive

BASES

1/2.2.1.2 DOSE (continued)

materials in liquid effluents are consistent with the methodology provided in Regulatory Guide 1.109, "Calculation of Annual Doses to Man from Routine Releases of Reactor Effluents for the Purposes of Evaluating Compliance with 10 CFR Part 50, Appendix I," Revision 1, October 1977 and Regulatory Guide 1.113, "Estimating Aquatic Dispersion of Effluents from Accidental and Routine Reactor Releases for the Purpose of Implementing Appendix I," April 1977.

This Control applies to the release of liquid effluents from each reactor at the site. For units with shared radwaste treatment systems, the liquid effluents from the shared systems are proportioned among the units sharing that system.

Compliance with this Control will be considered to demonstrate compliance with the 0.1 rem limit of 10 CFR Part 20.1301(a)(1) per 56 FR 23374.

1/2.2.1.3 LIQUID RADWASTE TREATMENT SYSTEM

The Control that the appropriate portions of this system be used when specified provides assurance that the releases of radioactive materials in liquid effluents will be kept "as low as reasonable achievable." This requirement implements the requirements of 10 CFR Part 50.36a, General Design Criteria 60 of 10 CFR Part 50 Appendix A, and the design objective given in 10 CFR Part 50 Appendix I, Section II.D. The specified limits governing the use of appropriate portions of the liquid radwaste system were specified as a suitable fraction of the dose design objectives set forth in 10 CFR Part 50 Appendix I, Section II.A, for liquid effluents.

1/2.2.2.1 DOSE RATE

This Control provides reasonable assurance that radioactive material discharged in gaseous effluents will not result in the exposure of a member of the public in an UNRESTRICTED AREA in excess of the design objectives of Appendix I to 10 CFR 50. This Control is provided to ensure that gaseous effluents from all units on the site will be appropriately controlled. It provides operational flexibility for releasing gaseous effluents to satisfy the Section II.A and II.C design objectives of Appendix I to 10 CFR 50. For members of the public who may at times be within the CONTROLLED or RESTRICTED AREAS, the occupancy of that member of the public will usually be sufficiently low to compensate for the reduced atmospheric dispersion relative to that for the UNRESTRICTED AREA BOUNDARY. Examples of calculations for such members of the public, with the appropriate occupancy factors, shall be given in the ODCM. The specified release rate limits restrict, at all times, the corresponding gamma and beta dose rates above background to a member of the public at or beyond the UNRESTRICTED AREA BOUNDARY to ≤ 500 mrem/y to the total body or to ≤ 3000 mrem/y to the skin. These limits also restrict, at all times, the corresponding thyroid dose rate above background to a child via the inhalation pathway to ≤ 1500 mrem/y. This Control does not affect the requirement to comply with the annual limitations of 10 CFR 20.1301(a).

This requirement applies to the release of radioactive material in gaseous effluents from all reactors at the site.

BASES

1/2.2 RADIOACTIVE EFFLUENTS

1/2.2.2.2 DOSE - NOBLE GASES

This requirement is provided to implement the requirements of 10 CFR Part 50 Appendix I, Sections II.B, III.A and IV.A. The requirement implements the guides set forth in Appendix I Section II.B. Compliance with this Control will be considered to demonstrate compliance with the 0.1 rem limit of 10 CFR Part 20.1301(a)(1) per 56 FR 23374. The action to be taken provides the required operating flexibility and at the same time implements the guides set forth in Section IV.A of Appendix I to assure that the releases of radioactive material in gaseous effluents will be kept "as low as reasonably achievable." The surveillance implements the requirements in Section III.A of Appendix I that conformance with the guides of Appendix I be shown by calculational procedures based on models and data such that the actual exposure of a member of the public through appropriately modeled pathways is unlikely to be substantially underestimated. The dose calculations established in ODCM Section 7.3 for calculating the doses due to the actual release rates of radioactive noble gases in gaseous effluents are consistent with the methodology provided in Regulatory Guide 1.109, "Calculation of Annual Doses to Man from Routine Releases of Reactor Effluents for the Purposes of Evaluating Compliance with 10 CFR Part 50, Appendix I," Revision 1, October 1977 and Regulatory Guide 1.111, "Methods for Estimating Atmospheric Transport and Dispersion of Gaseous Effluents in Routine Releases from Light-Water Cooled Reactors," Revision 1, July 1977. The ODCM equations provided for determining the air doses at the UNRESTRICTED AREA BOUNDARY are based upon the historical average atmospheric conditions.

1/2.2.2.3 DOSE - I-131, I-133, TRITIUM, AND RADIONUCLIDES IN PARTICULATE FORM WITH HALF-LIVES GREATER THAN EIGHT DAYS

This Control is provided to implement the requirements 10 CFR Part 50 Appendix I Sections II.C, III.A and IV.A. The requirement implements the guides set forth in Appendix I Section II.C. The action to be taken provides the required operating flexibility and at the same time implements the guides set forth in Appendix I Section IV.A to assure that the releases of radioactive material in gaseous effluents will be kept "as low as reasonably achievable." Section 7.4 calculational methods implement the requirements in Appendix I Section III.A that conformance with the guides of Appendix I be shown by calculational procedures based on models and data such that the actual exposure of a member of the public through appropriately modeled pathways is unlikely to be substantially underestimated. Section 7.4 calculational methods for calculating the doses due to the actual release rates of the subject materials are consistent with the methodologies provided in NUREG/CR-1004, "A Statistical Analysis of Selected Parameters for Predicting Food Chain Transport and Internal Dose of Radionuclides," October 1979 and Regulatory Guide 1.109, "Calculation of Annual Doses to Man from Routine Releases of Reactor Effluents for the Purposes of Evaluating Compliance with 10 CFR Part 50, Appendix I," Revision 1, October 1977 and Regulatory Guide 1.111, "Methods for Estimating Atmospheric Transport and Dispersion of Gaseous Effluents in Routine Releases from Light-Water Cooled Reactors," Revision 1, July 1977. These equations also provide for determining the actual doses based upon the historical average atmospheric conditions. The release rate specifications for Iodine-131, Iodine -133, tritium and all radionuclides in particulate form with half-lives greater than 8 days are dependent on the existing radionuclide pathways to man, beyond the UNRESTRICTED AREA BOUNDARY. The pathways which were examined in the development of these calculations were: 1) individual inhalation of airborne radionuclides, 2) deposition of radionuclides onto green leafy vegetation with subsequent consumption by man, 3) deposition onto grassy areas where milk animals and meat producing animals graze with consumption of the milk and meat by man, and 4) deposition on the ground with subsequent exposure of man.

BASES

1/2.2 RADIOACTIVE EFFLUENTS

1/2.2.2.4 GASEOUS RADWASTE TREATMENT

This Control that the appropriate portions of these systems be used, when specified, provides reasonable assurance that the releases of radioactive materials in gaseous effluents will be kept "as low as reasonably achievable." This Control implements the requirements of 10 CFR Part 50.36a, General Design Criteria 60 of 10 CFR Part 50 Appendix A, and the design objectives given in 10 CFR Part 50 Appendix I Section II.D. The specified limits governing the use of appropriate portions of the systems were specified as a suitable fraction of the dose design objectives set forth in 10 CFR Part 50 Appendix I Section II.B and II.C, for gaseous effluents.

1/2.2.3 TOTAL DOSE

This Control is provided to meet the dose limitations of 40 CFR Part 190 that have been incorporated into 10 CFR Part 20 by 46 FR 18525. Compliance with this Control will be considered to demonstrate compliance with the 0.1 rem limit of 10 CFR Part 20.1301(a)(1) per 56 FR 23374. The ACTION requires the preparation and submittal of a Special Report whenever the calculated doses due to releases of radioactivity and to radiation from uranium fuel cycle sources exceed 25 mrem to the total body or any other organ except thyroid, which shall be limited to less than or equal to 75 mrem. For sites containing up to 4 reactors, it is highly unlikely that the resultant dose to a member of the public will exceed the dose limits of 40 CFR Part 190 if the individual reactors remain within twice the dose design objectives of Appendix I and if direct radiation doses from the units and from outside storage tanks are kept small. The Special Report will describe a course of action that should result in the limitation of annual dose to a member of the public to within the 40 CFR Part 190 limits. For the purposes of the Special Report, it may be assumed that the dose commitment to the member of the public from other uranium fuel cycle sources is negligible, with the exception that dose contributions from other nuclear fuel cycle facilities at the same site or within a radius of 8 km must be considered.

If the dose to any member of the public is estimated to exceed the requirements of 40 CFR Part 190, the Special Report with a request for a variance (provide the release conditions resulting in violation of 40 CFR Part 190 have not already been corrected), in accordance with the provisions of 40 CFR Part 190.11 and 10 CFR Part 20.2203, is considered to be a timely request and fulfills the requirements of 40 CFR Part 190 until NRC staff action is completed. The variance only relates to the limits of 40 CFR Part 190, and does not apply in any way to the other requirements for dose limitation of 10 CFR Part 20, as addressed in ODCM Controls 1.2.1.1 and 1.2.2.1. An individual is not considered a member of the public during any period in which he/she is engaged in carrying out any operation that is a part of the nuclear fuel cycle.

BASES

1/2.3 RADIOLOGICAL ENVIRONMENTAL MONITORING

1/2.3.1 MONITORING PROGRAM

The radiological environmental monitoring program required by this Control provides representative measurements of radiation and of radioactive materials in those exposure pathways and for those radionuclides that lead to the highest potential radiation exposures of members of the public resulting from the station operation. This monitoring program implements Section IV.B.2 of Appendix I to 10 CFR Part 50 and thereby supplements the radiological effluent monitoring program by verifying that the measurable concentration of radioactive materials and levels of radiation are not higher than expected on the basis of the effluent measurements and modeling of the environmental exposure pathways. Guidance for this monitoring program is provided by the Radiological Assessment Branch Technical Position on Environmental Monitoring.

The required detection capabilities for environmental sample analyses are tabulated in terms of the lower limits of detection (LLDs). The LLDs required by Table 2.3-3 are considered optimum for routine environmental measurements in industrial laboratories. It should be recognized that the LLD is defined as an a priori (before the fact) limit representing the capability of a measurement system and not as an a posteriori (after the fact) limit for a particular measurement.

Detailed description of the LLD, and other detection limits can be found in HASL Procedures Manual, HASL-300 (revised annually), Curie, L. A., "Limits for Qualitative Detection and Quantitative Determination - Application to Radiochemistry," Anal. Chem. **40**, 586-93 (1968), and Hartwell, J. K., "Detection Limits for Radioanalytical Counting Techniques," Atlantic Richfield Hanford Company Report ARH-SA-215 (June 1975).

1/2.3.2 LAND USE CENSUS

This Control is provided to ensure that changes in the use of unrestricted areas are identified and that modifications to the monitoring program are made if required by the results of that census. The best survey information from the door-to-door, aerial, or consulting with local agricultural authorities shall be used. This census satisfies the requirements of Section IV.B.3 of Appendix I to 10 CFR Part 50. Restricting the census to gardens of greater than 500 ft² provides assurance that significant exposure pathways via leafy vegetables will be identified and monitored since a garden of this size is the minimum required to provide the quantity (26 kg/yr) of leafy vegetables assumed in Regulatory Guide 1.109 for consumption by a child. To determine this minimum garden size, the following assumptions were used, 1) that 20% of the garden was used for growing broad leaf vegetation (i.e., similar to lettuce and cabbage), and 2) a vegetation yield of 2 kg/m².

1/2.3.3 INTERLABORATORY COMPARISON PROGRAM

The requirement for participation in an Interlaboratory Comparison Program is provided to ensure that independent checks on the precision and accuracy of the measurements of radioactive material in environmental sample matrices are performed as part of the quality assurance program for environmental monitoring in order to demonstrate that the results are reasonably valid.

SECTION 3.0
DEFINITIONS

3.0 DEFINITIONS

The defined terms in this section appear in capitalized type in the text and are applicable throughout the ODCM.

3.1 ACTION

ACTION shall be that part of a Control that prescribes remedial measures required under designated conditions.

3.2 CHANNEL CALIBRATION

A CHANNEL CALIBRATION shall be the adjustment, as necessary, of the channel output such that it responds with the necessary range and accuracy to known values of the parameter which the channel monitors. The CHANNEL CALIBRATION shall encompass the entire channel including the sensor and alarm and/or trip functions, and shall include the CHANNEL FUNCTIONAL TEST. The CHANNEL CALIBRATION may be performed by any series of sequential, overlapping, or total channel steps such that the entire channel is calibrated.

3.3 CHANNEL CHECK

A channel check shall be the qualitative assessment of channel behavior during operation by observation. This determination shall include, where possible, comparison of the channel indication and/or status with other indications and/or status derived from independent instrument channels measuring the same parameter.

3.4 CHANNEL FUNCTIONAL TEST

A CHANNEL FUNCTIONAL TEST shall be:

- a. Analog channels - the injection of a simulated signal into the channel as close to the sensor as practicable to verify OPERABILITY including alarm and/or trip functions.
- b. Bistable channel - the injection of a simulated signal into the sensor to verify OPERABILITY including alarm and/or trip function.
- c. Digital channels - the injection of a simulated signal into the channel as close to the sensor input to the processor as practicable or the manipulation of a setpoint below existing background to verify operability including alarm and/or trip function.

3.5 CIRCUIT FAILURE shall be defined as the loss of circuit power to the monitor.

3.6 CONTROLLED AREA

A CONTROLLED AREA, as defined in 10 CFR 20, is the area outside the RESTRICTED AREA but inside the 10 CFR 20 defined UNRESTRICTED AREA BOUNDARY, access to which can be limited by the licensee for any reason (See Figure 3.1).

3.7 DOSE EQUIVALENT I-131

DOSE EQUIVALENT I-131 shall be that concentration of I-131 ($\mu\text{Ci}/\text{gram}$) which alone would produce the same thyroid dose as the quantity and isotopic mixture of I-131, I-132, I-133, I-134, and I-135 actually present. The thyroid dose conversion factors used for this calculation shall be those listed in Table III of TID-14844, "Calculation of Distance Factors for Power and Test Reactor Sites."

3.0 DEFINITIONS (continued)

3.8 FREQUENCY NOTATION

The FREQUENCY NOTATION specified for the Surveillance Requirements shall correspond to the intervals defined in Table 3.1.

3.9 GASEOUS RADWASTE TREATMENT SYSTEM

A GASEOUS RADWASTE TREATMENT SYSTEM is any system designed and installed to reduce radioactive gaseous effluents by collecting primary coolant system offgases from the primary system and providing for delay or holdup for the purpose of reducing the total radioactivity prior to release to the environment.

3.10 OPERABLE - OPERABILITY

A system, subsystem, train, component, or device shall be OPERABLE or have OPERABILITY when it is capable of performing its specified function(s), and when all necessary attendant instrumentation, controls, a normal or an emergency electrical power source, cooling or seal water, lubrication or other auxiliary equipment that are required for the system, subsystem, train, component, or device to perform its function(s) are also capable of performing their related support function.

3.11 MODE

A MODE shall correspond to any one inclusive combination of core reactivity condition, power level, and average reactor coolant temperature specified in Table 1.1 of the SQN Technical Specifications.

3.12 PURGE - PURGING

PURGE or PURGING is the controlled process of discharging air or gas from a confinement to maintain temperature, pressure, humidity, concentration or other operating condition, in such a manner that replacement air or gas is required to purify the confinement.

3.13 RADIATION MONITOR (RM) OR (R)

A radiation monitor is identified by "RM" under instrumentation. To be OPERABLE, it is minimally defined as an instrumentation channel that includes the radiation detector, associated sample delivery system, signal processing electronics, malfunction alarm, high radiation alarm, and at least one indicator (main control room, local, or computer point).

3.14 RATED THERMAL POWER

RATED THERMAL POWER shall be a total reactor core heat transfer rate to the reactor coolant of 3455 RTP

3.15 REPORTABLE EVENT

A REPORTABLE EVENT shall be any of those conditions specified in Section 50.73 of 10 CFR 50.

3.0 DEFINITIONS (continued)

3.16 RESTRICTED AREA

The RESTRICTED AREA, as defined in 10 CFR Part 20, is that area, access to which is limited by the licensee for the purposes of protecting individuals against undue risks from exposure to radiation and radioactive materials. The permanent RESTRICTED AREA is shown on Figure 3.1, but temporary restricted areas outside the permanent RESTRICTED AREA may be defined by SQN.

3.17 SITE BOUNDARY

The site boundary is defined in 10 CFR 20 as that line beyond which the land or property is not owned, leased, or otherwise controlled by the licensee.

3.18 SOURCE/SENSOR CHECK

A SOURCE/SENSOR CHECK shall be the qualitative assessment of channel response when the channel sensor is exposed to a radioactive source or other channel sensor internal test circuit.

3.19 UNRESTRICTED AREA/BOUNDARY

An UNRESTRICTED AREA/BOUNDARY, as used for calculations performed pursuant to 10 CFR Part 50.36a, shall be an area at or beyond the site boundary which is utilized in the ODCM Controls to keep levels of radioactive materials in liquid and gaseous effluents as low as is reasonably achievable. The UNRESTRICTED AREA does not include areas over water bodies (See Figure 3.1).

3.20 VENTILATION EXHAUST TREATMENT SYSTEM

A VENTILATION EXHAUST TREATMENT SYSTEM is any system designed and installed to reduce gaseous radioiodine or radioactive material in particulate form in effluents by passing ventilation or vent exhaust gases through charcoal adsorbers and/or HEPA filters for the purpose of removing iodines or particulates from the gaseous exhaust stream prior to the release to the environment (such a system is not considered to have any effect on noble gas effluents). Engineered Safety Feature (ESF) atmospheric cleanup systems are not considered to be VENTILATION EXHAUST TREATMENT SYSTEM components.

3.21 VENT FLOW RATE MONITOR (F)

The vent flow rate monitors are identified by "F" under instrumentation. To be OPERABLE is minimally defined as an instrumentation channel that includes the flow sensor, processing electronics and at least one indicator (main control room, local or computer point).

3.22 VENTING

VENTING is the controlled process of discharging air or gas from a confinement to maintain temperature, pressure, humidity, concentration, or other operating condition, in such a manner that replacement air or gas is not provided or required during VENTING. Vent, used in system names, does not imply a VENTING process.

Table 3.1 FREQUENCY NOTATION

NOTATION FREQUENCY

P	Completed prior to each release
D	At least once per day
W	At least once per 7 days
B	At least once per 15 days
M	At least once per 31 days
Q	At least once per 92 days
R	At least once per 18 months
S	At least semi-annual
NA	Not Applicable

Figure 3.1 UNRESTRICTED AREA BOUNDARY

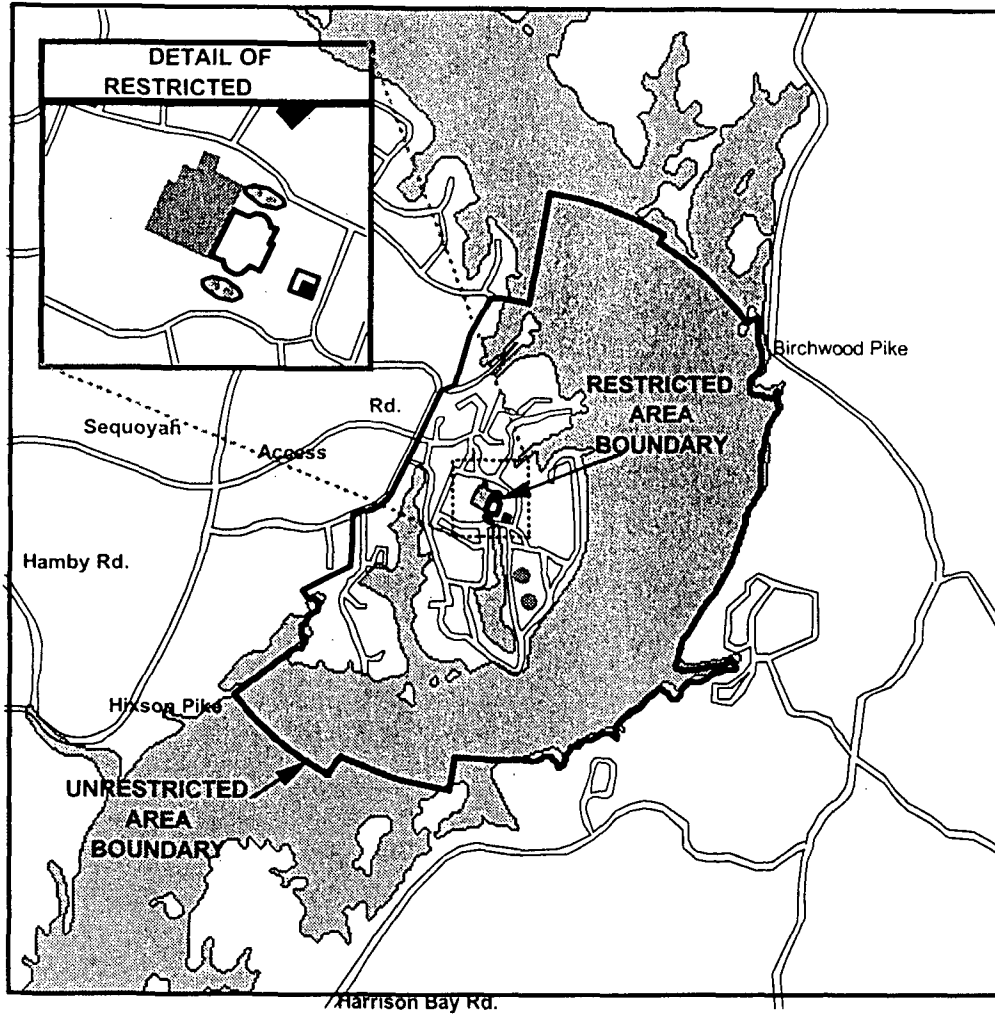

Area between the RESTRICTED AREA and the UNRESTRICTED AREA BOUNDARIES is the CONTROLLED AREA. Dark shaded area outside the UNRESTRICTED AREA BOUNDARY is the UNRESTRICTED AREA.

SECTION 4.0
(NOT USED)

SECTION 5.0
ADMINISTRATIVE CONTROLS

5.0 ADMINISTRATIVE CONTROLS

5.1 ANNUAL RADIOLOGICAL ENVIRONMENTAL OPERATING REPORT

As required by SNQ Technical Specification 6.9.1.6, the Annual Radiological Environmental Operating Report covering the operation of the unit during the previous calendar year shall be submitted prior to May 1 of each year.

The annual radiological environmental operating reports shall include summaries, interpretations, and an analysis of trends of the results of the radiological environmental surveillance activities for the report period, including a comparison with preoperational studies, operational controls (as appropriate), and previous environmental surveillance reports and an assessment of the observed impacts of the plant operation on the environment. The reports shall also include the results of land use censuses required by ODCM Control 1.3.2 and a listing of the new locations for dose calculations and/or environmental monitoring identified by the land use census. If harmful effects or evidence of irreversible damage are detected by the monitoring, the report shall provide an analysis of the problems and a planned course of action to alleviate the problem.

The annual radiological environmental operating reports shall include summarized and tabulated results in the format of Regulatory Guide 4.8, December 1975 of all radiological environmental samples taken during the report period. In the event that some results are not available for inclusion with the report, the report shall be submitted noting and explaining the reasons for the missing results. The missing data shall be submitted as soon as possible in a supplementary report.

The reports shall also include the following: a summary description of the radiological environmental monitoring program; a map of all sampling locations keyed to a table giving distances and directions from one reactor; and the results of licensee participation in the Interlaboratory Comparison Program required by ODCM Control 1.3.3.

5.2 ANNUAL RADIOACTIVE EFFLUENT RELEASE REPORT

As required by SNQ Technical Specification 6.9.1.8, an Annual Radioactive Effluent Release Report covering the operation of the site during the previous calendar year of operation shall be submitted prior to May 1 of each year.

Annual radioactive release reports shall include a summary of the quantities of radioactive liquid and gaseous effluents and solid waste released from the site as outlined in Regulatory Guide 1.21, "Measuring, Evaluating, and Reporting Radioactivity in Solid Wastes and Releases of Radioactive Materials in Liquid and Gaseous Effluents from Light-Water-Cooled Nuclear Power Plants," Revision 1, June 1974, with data summarized on a quarterly basis following the format of Appendix B thereof.

The annual radioactive release report shall include unplanned releases from the site to unrestricted areas and shall also include any changes made to the ODCM pursuant to ODCM Administrative Control 5.3.

5.0 ADMINISTRATIVE CONTROLS

5.2 ANNUAL RADIOACTIVE EFFLUENT RELEASE REPORT (continued)

The annual radioactive effluent release report shall include information for solid waste as outlined in the Process Control Program, and shall also include any changes made to the PCP during the reporting period, to the ODCM pursuant to ODCM Administrative Control 5.3, as well as any major changes to Liquid, Gaseous, or Solid Radwaste Treatment Systems, pursuant to SQN Technical Specifications. It shall also include a listing of new location for dose calculations and/or environmental monitoring identified by the Land Use Census pursuant to ODCM Control 1.3.2.

The radioactive effluent release reports shall also include the following: an explanation as to why the inoperability of liquid or gaseous effluent monitoring instrumentation was not corrected within the time specified in ODCM Controls 1.1.1 or 1.1.2 respectively.

The annual radioactive effluent release report (Radiological Impact) shall include an annual summary of hourly meteorological data collected over the previous year. This annual summary may be either in the form of an hour-by-hour listing of wind speed, wind direction, atmospheric stability, and precipitation (if measured) on magnetic tape, or in the form of joint frequency distributions of wind speed, wind direction, and atmospheric stability. In lieu of submission with the annual radioactive effluent release report, this summary of required meteorological data may be retained on site in a file that shall be provided to NRC upon request). This same report shall include an assessment of the radiation doses due to radioactive liquid and gaseous effluents released from the unit or station during the previous calendar year. This same report shall also include an assessment of the radiation doses from radioactive liquid and gaseous effluents to members of the public due to their activities inside the UNRESTRICTED AREA BOUNDARY (Figure 3.1) during the report period. All assumptions used in making these assessments (i.e., specific activity, exposure time, and location) shall be included in these reports.

The meteorological conditions concurrent with the time of release of radioactive materials in gaseous effluents (as determined by sampling frequency and measurement) shall be used for determining the gaseous pathway doses. The assessment of radiation doses shall be performed in accordance with Sections 6.6 and 7.6.

The annual radioactive effluent release report to be submitted after January 1 of each year shall also include an assessment of radiation doses to the likely most exposed members of the public from reactor releases and other nearby uranium fuel cycle sources (including doses from primary effluent pathways and direct radiation) for the previous calendar year to show conformance with 40 CFR 190, Environmental Radiation Protection Standards for Nuclear Power Operation, in accordance with ODCM Section 8.0. Acceptable methods for calculating the dose contribution from liquid and gaseous effluents are given in Regulatory Guide 1.109, Revision 1.

5.0 ADMINISTRATIVE CONTROLS

5.3 OFFSITE DOSE CALCULATION MANUAL CHANGES

As required by SQN Technical Specification 6.14 and Appendix A, changes to the ODCM:

1. Shall be documented and records of reviews performed shall be retained in a manner convenient for review. This documentation shall contain:
 - a. Sufficient information to support the change together with the appropriate analyses or evaluations justifying the change(s) and
 - b. A determination that the change will maintain the level of radioactive effluent control required by 10 CFR Part 20.1302, 40 CFR Part 190, 10 CFR Part 50.36a, and Appendix I to 10 CFR Part 50 and not adversely impact the accuracy or reliability of effluent, dose, or setpoint calculations.
2. Shall become effective after review and acceptance by the process described in TVA-NQA-PLN89-A .
3. Shall be submitted to the Commission in the form of a complete, legible copy of the entire ODCM as a part of or concurrent with the Annual Radioactive Effluent Release Report for the period of the report in which any change to the ODCM was made. Each change shall be identified by markings in the margin of the affected pages, clearly indicating the area of the page that was changed, and shall indicate the date (i.e., month/year) the change was implemented.

Changes to the ODCM shall be performed in accordance with the requirements of Appendix A.

5.4 SPECIAL REPORTS

Special Reports shall be submitted within the time period specified for each report, in accordance with 10 CFR Part 50.4.

SECTION 6.0
LIQUID EFFLUENTS

SECTION 6.0 LIQUID EFFLUENTS

RELEASE POINTS

There are four systems from which liquid effluents are released to the environment. These are the Liquid Radwaste System, the Condensate Demineralizer System, the Turbine Building Sump (TBS), and the Units 1 and 2 Steam Generator Blowdown. Figure 6.1 provides an outline of the liquid release paths and discharge points with associated flow rates and radiation monitors.

All liquid effluents are ultimately discharged to the Diffuser Pond which releases to the Tennessee River where they are evaluated for offsite dose. The Essential Raw Cooling Water (ERCW) continuously supplies the Cold Water Channel which routinely provides dilution for liquid effluents at a minimum flow rate of 15,000 gpm. However, a minimum 17,000 gpm operational requirement is in place utilizing the ICS computer point 0F2120DIF to ensure the 15,000 gpm requirement is adhered. ERCW flow is monitored by radiation monitors 0-RM-90-133, -134, -140, -141.

Releases are made as either batch or continuous release. Releases from Radwaste Tanks are made as batch releases. The TBS and SGBD are continuous releases when flow exists. The Condensate Demineralizer tanks are routinely released as continuous release to the TBS, but can be released as batch release to the CTBD.

For batch releases, any tank to be released is sampled for activity, as described in ODCM Section 6.1.1. The tank contents are analyzed to determine the maximum allowable release flow rates to ensure compliance with concentration limits of ODCM Control 1.2.1.1 as described in ODCM Section 6.1.2. The sampling results are also used to determine a setpoint for the associated radiation monitor for the release in accordance with ODCM Section 6.2.3. Pre-release calculations are performed assuming the minimum dilution of 15,000 gpm.

For continuous releases, the pathways are sampled for radioactivity periodically, as described in ODCM Section 6.1.1. The samples are analyzed to ensure compliance with concentration limits of ODCM Control 1.2.1.1, as described in ODCM Section 6.1.2. The sampling results are also used to determine a setpoint for the associated radiation monitor for the release in accordance with ODCM Section 6.2.3. Pre-release calculations for points other than the Turbine Building Sump are performed assuming the minimum dilution flow of 15,000 gpm. The pre-release calculation for SGBD may be performed using 0 for the dilution flow and SGBD may be in-service to the CTBD with no dilution flow when the ECL for the SGBD is < 10.

Liquid Radwaste System

The Liquid Radwaste System processes liquid from the Reactor Building and Auxiliary Building Floor Drains and the laundry/hot shower and chemical drain tanks. Figure 6.2 provides a schematic of the Liquid Radwaste System, showing the liquid pathways, flow rate and radiation monitors. The normal release points for liquid radwaste are the Monitor Tank and the Cask Decontamination Collector Tank (CDCT). The Monitor Tank has a capacity of 22,000 gal and is released routinely at a flow rate of 125 gpm. The CDCT has a capacity of 15,000 gal and is also released routinely at a flow rate of 125 gpm. The Monitor Tank and CDCT discharge to the Cooling Tower Blowdown (CTBD) line as a batch release and are monitored by radiation monitor 0-RM-90-122.

Condensate Demineralizer System

The Condensate Demineralizer System processes liquid wastes coming from the High Crud Tanks (HCT-1 and -2), the Neutralization Tank, and the Non-Reclaimable Waste Tank (NRWT). The HCTs have a capacity of 20,000 gal and a maximum discharge flow rate of 245 gpm. The Neutralization Tank has a capacity of 19,000 gal and a maximum discharge flow rate of 245 gpm. The NRWT has a capacity of 11,000 gal and a maximum discharge flow rate of 245 gpm. The Condensate Demineralizer System is routinely released as continuous releases during periods of low radioactivity levels to the TBS, but can be released to the CTBD and is monitored by radiation monitor 0-RM-90-225.

Turbine Building Sump

The Turbine Building Sump (TBS) normally releases to the Low Volume Waste Treatment Pond (LVWTP) but can be released to the Yard Pond. The TBS has a capacity of 30,000 gal and a design discharge release rate of 1,750 gpm per pump. TBS releases are monitored by radiation monitor 0-RM-90-212.

Steam Generator Blowdown

The Steam Generator Blowdown (SGBD) is processed in the Steam Generator Draindown Flash Tanks or SGBD Heat Exchangers. The SGBD discharge has a maximum flow rate of 80 gpm per steam generator. SGBD discharges to the CTBD line are continuous and are monitored by radiation monitors 1,2-RM-90-120, -121.

6.1 LIQUID RELEASES

6.1.1 Pre-Release Analysis

To ensure representative sampling, radwaste tanks will be recirculated for a procedurally established length of time, or through two volumes. Periodically, checks will be made to ensure a representative mixing of tank contents. All radwaste tanks will be released as "batch" releases.

Releases from condensate demineralizer tanks are routinely continuous releases^a and utilize a composite sampler to obtain a representative sample while being discharged. In the event of an inoperable composite sampler, the releases will be made as a batch release, and will be recirculated for a procedurally established length of time or through two volumes to ensure representative sampling.

Steam generator blowdown and turbine building sump^a are considered continuous and grab sampled daily during releases.

Prior to any batch release, a grab sample will be taken and analyzed to determine the concentration, $\mu\text{Ci/ml}$, of each gamma-emitting nuclide. For continuous releases, daily grab or composite samples will be taken on days when releases are being made and analyzed to determine the concentration, $\mu\text{Ci/ml}$, of each gamma-emitting nuclide. Composite samples are maintained during periods of radioactive discharge from all pathways (as required by Table 2.2-1) to determine the concentration of certain nuclides (H-3, Fe-55, Sr-89, Sr-90, and alpha emitters).

For those nuclides whose activities are determined from composite samples, the concentrations for the previous composite period can be assumed as the concentration for the next period to perform the calculations in Sections 6.3 and 6.5. The actual measured concentrations will be used for the dose calculations described in Section 6.6.

^a Sampling requirements for these release points are applicable only during periods of significant primary to secondary leakage or the release of radioactivity as detected by the effluent radiation monitor provided the radiation monitor setpoint is at a LLD of $\leq 1\text{E-}06 \mu\text{Ci/ml}$ and allowing for background radiation during periods when primary to secondary leakage is occurring. Sampling and analysis is routinely performed versus utilizing the radiation monitor at this LLD.

6.1.2 Effluent Concentration Limits (ECL)-Sum of the Ratios

The sum of the ratios (R_j) for each release point will be calculated by the following relationship.

$$R_j = \sum_i \frac{C_i}{\text{ECL}_i} \quad (6.1)$$

where:

R_j = the sum of the ratios for release point j.

ECL_i = the ECL of radionuclide i, $\mu\text{Ci/ml}$, from 10 CFR Part 20, Appendix B, Table 2, Column 2.

C_i = concentration of radionuclide i, $\mu\text{Ci/ml}$.

The sum of the ECL ratios must be ≤ 10 following dilution at the Cooling Tower Blowdown due to the releases from any or all of the release points described above. The ECL ratios for releases from the Turbine Building Sump will be ≤ 10 at the sump.

The following relationship is used to ensure that this criterion is met:

$$R_{TBS} + \frac{f_1 R_1 + f_2 R_2 + f_3 R_3 + f_4 R_4}{F} \leq 10.0 \quad (6.2)$$

where

R_{TBS} = sum of the ECL ratios of the turbine building sump as determined by equation 6.1.

f_1, f_2, f_3, f_4 = effluent flow rate for radwaste, condensate demineralizer system and each of the steam generator blowdowns, respectively, gpm.

R_1, R_2, R_3, R_4 = sum of ECL ratios for radwaste, condensate demineralizer system and each of the steam generator blowdowns, respectively, as determined by equation 6.1.

F = dilution flow rate for CTBD, routinely 15,000 gpm.

6.1.3 Post-Release Analysis

A post-release evaluation will be done using actual release data to ensure that the limits specified in ODCM Control 1.2.1.1 were not exceeded. This analysis will include an evaluation of the noble gas concentration with regard to ODCM Control 1.2.1.1.

A composite list of concentrations (C_i), by isotope, will be used with the actual waste (f) and dilution (F) flow rates (or volumes) during the release. The data will be evaluated to demonstrate compliance with the limits in ODCM Control 1.2.1.1.

6.2 INSTRUMENT SETPOINTS

Liquid effluent monitor setpoints are determined to ensure that the concentration of radioactive material released at any time from the site to UNRESTRICTED AREAS does not exceed ten times the ECL limits referenced in ODCM Control 1.2.1.1 and to identify any unexpected releases. The essential raw cooling water (ERCW) will be used for dilution for liquid effluents; however, the very large dilution factors afforded by the circulating coolant will not be used to allow high concentrations of liquid radioactive waste to be discharged from the plant.

6.2.1 Discharge Point Monitor Setpoints (0-RM-90-133,134,140,141)

The setpoints for the ERCW monitors (RM-90-133, 134, 140, 141) are set to ensure that the concentration of radioactive materials released at any time from the site do not exceed the limits given in ODCM Control 1.2.1.1. The setpoints for these monitors will be set at a small value above background to ensure that any radioactivity is identified. Site procedures will document and control this value.

6.2.2 Release Point Monitor Setpoints (0-RM-90-122; 0-RM-90-225; 0-RM-90-212; 1,2-RM-90-120,121)

There are five liquid release point effluent monitors: the Liquid Radwaste System radiation monitor 0-RM-90-122; the Condensate Demineralizer System radiation monitor 0-RM-90-225; the Turbine Building Sump radiation monitor 0-RM-90-212; and the Steam Generator Blowdown (SGBD) radiation monitors 1,2-RM-90-120,121.

The batch release points, the Liquid Radwaste System and the Condensate Demineralizer System (if being released in a batch mode), are looking at an undiluted waste stream as it comes out of a tank. The purpose of the monitor setpoints for these batch releases is to identify any release that is larger than expected and would have the potential to exceed the limits after dilution. Setpoints are calculated as described in Section 6.2.3.

The continuous release points, the Condensate Demineralizer System, the Steam Generator Blowdowns, and the Turbine Building Sump, will not be releasing radioactivity unless there is or has been a primary to secondary leak. When there is no identified primary to secondary leakage, these release points are monitored to indicate the presence of elevated activity levels in these systems. The setpoints for these monitors will be set to alarm if the activity in the stream exceeds a routine nominal background. These setpoints are controlled by site instructions.

When there is identified significant primary to secondary leakage, the continuous release points are monitored to identify any release that is larger than expected or would have the potential to exceed the 10 CFR Part 20 limits after dilution. The monitor setpoints are calculated in the same manner as the batch release point monitor setpoints (described in Section 6.2.3) when this is the case. When these release points are being treated in this manner, a single batch release is defined as all effluent released through this point on a continuous bases for a period of time (usually one week).

6.2.3 Batch Release Point Monitor Setpoint

For each release from a release point, two setpoints are calculated: one based on the monitor response to the contents of the effluent stream multiplied by an administrative factor to account for monitor fluctuations; and another based on the predicted response of the monitor to the activity in the release stream if it were large enough to exceed ten times the 10 CFR Part 20 limits after dilution. The expected monitor response, R in cpm, is calculated using equation 6.3 below.

The maximum calculated setpoint, S_{max} , is calculated using Equation 6.4 below. A comparison is made between these two calculated setpoints to determine which is used. The actual monitor setpoint for the release

is set equal to X times the expected radioactivity response plus background, or to the maximum calculated setpoint, whichever is less. X is an administrative factor designed to account for expected variations in monitor response (it will be defined in approved plant instructions). The X times expected response setpoint allows for the identification of any release of radioactivity above the expected amount. The maximum calculated setpoint ensures that the release will be stopped if it exceeds ten times the 10 CFR Part 20 concentration limits after dilution.

Expected response / Expected Response Setpoint (Ser)

$$R = B + \sum_i \text{Eff}_i * C_i \tag{6.3}$$

$$\text{Ser} = X * R$$

where

B = monitor background, cpm.

Eff_i = monitor efficiency for nuclide i, cpm per μCi/ml.

C_i = tank concentration of nuclide i, μCi/ml.

X = Administrative Factor designed to account for expected variations in monitor response and background (The range of values is 1.5 ≤ X ≤ 2.0).

Calculated Maximum Monitor Setpoint

$$S_{\text{max}} = \frac{10 \text{ FS } (F_w + (A * F_{\text{dil}}))}{F_w R_j} (R - B) + B \tag{6.4}$$

where

FS = fluctuation safety factor for the monitor, which is set at 1.0 ≤ SF ≤ 1.5. The factor is set to account for minor changes in monitor response and background.

F_w = flow of waste stream, gpm.

F_{dil} = flow of the dilution stream, routinely set @ 15,000 gpm.

A = fraction of dilution flow allocated to this release point. For the TBS, this fraction is zero. The fractions for the remaining 4 release points are defined as the ratio of the allocated CTBD flow for that release point to the total CTBD flow. The CTBD flow allocation fractions for these release points are routinely:

Radwaste	0.60
Condensate demineralizer	0.20
Steam Generator Blowdown (U1)	0.10
Steam Generator Blowdown (U2)	0.10

NOTE: These allocation factors may be adjusted for a particular release if it is known that there are no releases being made through other release points into the CTBD. For example, if there are no releases being made through the Condensate Demineralizer or either Steam Generator Blowdown, the allocation factor for the Radwaste System may be set equal to one.

R_j = sum of the ECL ratios for release point j as calculated in Section 6.1.2.

R = expected monitor response, cpm, as calculated above.

B = background, cpm.

10 = ECL ratio limit at the Cooling Tower Blowdown discharge.

6.3 CUMULATIVE LIQUID EFFLUENT DOSE CALCULATIONS

Doses due to liquid effluents are calculated for each release for all age groups: adult (≥17 years of age), teen (≥11, but <17 years), child (≥1, but <11 years) and infant (0-1 years) and organs: bone, liver, total body, thyroid, skin, kidney, lung and GI tract. Pathways considered are ingestion of drinking water, fish consumption and

recreation-shoreline. The maximum individual dose from drinking water is assumed to be that calculated at the location immediately downstream from the diffuser in the Tennessee River. The maximum individual dose from fish ingestion is assumed to be that calculated for the consumption of fish caught anywhere between the plant and the first downstream dam (Chickamauga Dam). The maximum potential recreation dose is calculated for a location immediately downstream of the plant outfall. Dose factors for these age groups and pathways are calculated as described in Section 6.7. For pathways with no age or organ specific dose factors (i.e. shoreline recreation), the total body dose will be added to the internal organ doses for all age groups.

The general equation for the dose calculations is:

$$\text{Dose} = \sum_i A_{it} T C_i D \quad (6.5)$$

where:

- A_{it} = the total dose factor to the total body or any organ t for nuclide i , mrem/hr per $\mu\text{Ci/ml}$. The total dose factor is the sum of the dose factors for water ingestion, fish ingestion, and shoreline recreation, as defined in Section 6.7.
- T = the length of time period over which the concentrations and the flows are averaged for the liquid release, hours.
- C_i = the average concentration of radionuclide i , in undiluted liquid effluent during the time period T from any liquid release, $\mu\text{Ci/ml}$.
- D = the near field average dilution factor for C_i during any effluent release. D is calculated by the following equation:

$$D = \frac{\text{FLOW}_w}{0.60 \text{ RF}}$$

where:

- FLOW_w = maximum undiluted liquid waste flow during the release, cfs. For TBS releases, this term is the diluted waste flow into the pond.
- 0.60 = mixing factor of effluent in river, defined as the percentage of the river flow which is available for dilution of the release.
- RF = default riverflow, cfs. For each release, this value is set to 7900 cfs (the lowest average quarterly riverflow recorded from the period 1978-1988).

From the four age groups considered, the maximum is determined by comparing all organ doses for all age groups. The age group with the highest single organ dose is selected as the critical age group. The total body and maximum organ doses for the critical age group are used in the calculation of the monthly dose described in Section 6.3.1.

6.3.1 Monthly Dose Calculations

At the end of each month, the actual average riverflow for the month is used to recalculate the liquid doses. The monthly cumulative dose is defined as the sum of the doses for the critical age group for each release during the month. Thus, the monthly cumulative dose will be a conservative value, consisting of doses belonging to various age groups depending on the mix of radionuclides. These doses are multiplied by the ratio of the default riverflow (7900 cfs) to the actual monthly average riverflow to obtain the monthly dose. The total body and maximum organ doses determined in this manner are then used to determine the cumulative quarterly and annual doses described in Section 6.3.2, and for the dose projections described in Section 6.5.

6.3.2 Cumulative Doses

Quarterly and annual sums of all doses are determined at the end of each month to compare to the limits given in ODCM Control 1.2.1.2. These quarterly and annual sums will be the sum of the monthly cumulative doses described in Section 6.3.1 for the appropriate months in the quarter or year. These doses will be used in the comparison to the limits.

6.3.3 Comparison to Limits

The cumulative calendar quarter and calendar year doses are compared to the limits in ODCM Control 1.2.1.2 once per 31 days to determine compliance.

6.4 LIQUID RADWASTE TREATMENT SYSTEM

The liquid radwaste treatment system described below shall be maintained and operated to keep releases ALARA.

A flow diagram for the LRTS is given in Figure 6.2. The system consists of one reactor coolant drain tank with two pumps and a floor and equipment drain sump inside the containment of each unit and the following shared equipment inside the auxiliary building: one sump tank and pumps, one tritiated drain collector tank with two pumps and one filter, one floor drain collector tank with two pumps and one filter, a waste condensate tank filter, three waste condensate tanks and two pumps, a chemical drain tank and pump, two laundry and hot shower tanks and pump, a spent resin storage tank, a cask decontamination tank with two pumps and two filters, Auxiliary Building floor end equipment drain sump and pumps, and evaporator with two distillate tanks, a Mobile Waste Demineralizer System (if needed) and the associated piping, valves and instrumentation.

6.5 DOSE PROJECTIONS

In accordance with ODCM Surveillance Requirement 2.2.1.3, dose projections will be performed by averaging the two previous month's doses as determined in Section 6.3.1. To determine compliance with the limits, these averages are assigned as the dose projections for the upcoming month.

The projected doses are compared to the limits of ODCM Control 1.2.1.3. If the projected doses exceed 0.06 mrem per reactor unit to the total body or 0.2 mrem per reactor unit to any organ in a 31-day period, the liquid radwaste treatment system shall be used to reduce the radioactive materials in liquid wastes prior to their discharge to UNRESTRICTED AREAS.

$$D = \frac{a + b}{2}$$

where:

- D = the 31-day dose projection, mrem
- a = the cumulative dose for the previous month, mrem
- b = the cumulative dose for the present month, mrem

6.6 QUARTERLY DOSE CALCULATIONS

A complete dose analysis utilizing the total estimated liquid releases for each calendar quarter will be performed and reported as required in ODCM Administrative Control 5.2. Methodology for this analysis is that which is described in this section using the quarterly release values reported by the plant personnel. The releases are assumed, for this calculation, to be continuous over the 90 day period.

The average dilution factor, D, used for the quarterly calculations is:

$$D = \frac{1}{RF * 0.60} \quad \text{(for receptors upstream of Chickamauga Dam)} \quad (6.6)$$

and

$$D = \frac{1}{RF} \quad \text{(for receptors downstream of Chickamauga Dam)} \quad (6.7)$$

where:

RF = the average actual riverflow for the location at which the dose is being determined, cfs.
0.60 = the fraction of the riverflow available for dilution in the near field, dimensionless.

6.6.1 WATER INGESTION

Water ingestion doses are calculated for each water supply identified within a 50 mile radius downstream of SQN (Table 6.1). The summation of water ingestion doses are calculated for the total body and each internal organ as described below:

$$D_{org} = 10^6 9.80E-09 0.25 \sum A_{Wit} Q_i D \exp(-8.64E+04 \lambda_i t_d) \quad (6.8)$$

where

10^6 = conversion factor, $\mu\text{Ci}/\text{Ci}$.

$9.80E-09$ = conversion factor, cfs per ml/h.

0.25 = fraction of the yearly water consumption in one quarter, dimensionless

A_{Wit} = dose factor for water ingestion for nuclide i, age group t, mrem/h per $\mu\text{Ci}/\text{ml}$, as calculated in Section 6.7.1.

Q_i = Quantity of nuclide i released during the quarter, Ci.

D = dilution factor, as described above, cfs^{-1} .

λ_i = radiological decay constant of nuclide i, s^{-1} (Table 6.2).

t_d = decay time for water ingestion, equal to the travel time from the plant to the water supply plus one day to account for the time of processing at the water supply (per Regulatory Guide 1.109), d.

$8.64E+04$ = conversion factor, seconds per day.

6.6.2 FISH INGESTION

Fish ingestion doses are calculated for each identified reach within a 50 mile radius downstream of SQN (Table 6.1). The summation of individual fish ingestion doses are calculated for the total body and each internal organ as described below:

$$D_{org} = 10^6 \cdot 9.80E-09 \cdot 0.25 \cdot \sum A_{Fit} \cdot Q_i \cdot D \cdot \exp(-8.64E+04 \lambda_i t_d) \quad (6.9)$$

where

- 10^6 = conversion factor, $\mu\text{Ci}/\text{Ci}$.
- $9.80E-09$ = conversion factor, cfs per ml/h.
- 0.25 = fraction of the yearly fish consumption eaten in one quarter, dimensionless.
- A_{Fit} = dose factor for fish ingestion for nuclide i , age group t , mrem/h per $\mu\text{Ci}/\text{ml}$, as calculated in Section 6.7.2.
- Q_i = Quantity of nuclide i released during the quarter, Ci.
- D = dilution factor, as described above, cfs^{-1} .
- λ_i = radiological decay constant of nuclide i , s^{-1} (Table 6.2).
- t_d = decay time for fish ingestion, equal to the travel time from the plant to the center of the reach plus one day to account for transit through the food chain and food preparation time (per Regulatory Guide 1.109), d.
- $8.64E+04$ = conversion factor, seconds per day.

6.6.3 SHORELINE RECREATION

Recreation doses are calculated for each identified reach within a 50 mile radius downstream of SQN (Table 6.1). It is assumed that the maximum exposed individual spends 500 hours per year on the shoreline at a location immediately downstream from the diffusers. The summation of individual recreation shoreline doses are calculated for the total body and skin as described below:

$$D_{org} = 10^6 \cdot 9.80E-09 \cdot rf \cdot \sum A_{Rit} \cdot Q_i \cdot D \cdot \exp(-8.64E+04 \lambda_i t_d) \quad (6.10)$$

where

- 10^6 = conversion factor, $\mu\text{Ci}/\text{Ci}$.
- $9.80E-09$ = conversion factor, cfs per ml/h.
- rf = recreation factor, used to account for the fact that the same amount of time will not be spent at a recreation site during each quarter. Recreation factors used are:
1st quarter - 0.1 2nd quarter - 0.3 3rd quarter - 0.4 4th quarter - 0.2.
- A_{Rit} = dose factor for shoreline recreation for nuclide i , age group t , mrem/h per $\mu\text{Ci}/\text{ml}$, as calculated in Section 6.7.3.
- Q_i = Quantity of nuclide i released during the quarter, Ci.
- D = dilution factor, as described above, cfs^{-1} .
- λ_i = radiological decay constant of nuclide i , s^{-1} (Table 6.2).
- t_d = decay time for recreation, equal to the travel time from the plant to the center of the reach, d.
- $8.64E+04$ = conversion factor, seconds per day.

6.6.4 TOTAL MAXIMUM INDIVIDUAL DOSE

The total maximum individual total body dose is obtained by summing the following for each age group: the highest total body water ingestion dose from among all the public water supplies; the highest total body fish ingestion dose from among all the reaches; and the total body maximum shoreline recreation dose. The total maximum individual organ dose is obtained by summing the following for each organ and each age group: that organ's highest water ingestion dose from among all the public water supplies; that organ's highest fish ingestion dose from among all the reaches; and the total body maximum shoreline recreation dose. The total maximum individual skin dose is that skin dose calculated for the maximum shoreline dose.

6.6.5 POPULATION DOSES

For determining population doses to the 50-mile population around the plant, an average dose is calculated for each age group and each pathway and then multiplied by the population.

For water ingestion, the general equation used for calculating the population doses, POPWTR, in man-rem for a given PWS is:

$$POPWTR_t = 10^{-3} \sum_{m=1}^4 POP_m \sum_{a=1}^4 POP_a ATMW_a TWDOS_{amt} \quad (6.11)$$

where:

POPWTR_t = water ingestion population dose to organ t, man-rem.

POP_a = fraction of population in each age group a (from NUREG CR-1004, table 3.39).

Adult = 0.665

Child = 0.168

Infant = 0.015

Teen = 0.153

POP_m = population at PWS m. The 4 PWSs and their populations are listed in Table 6.1.

ATMW_a = ratio of average to maximum water ingestion rates for each age group a. Maximum water ingestion rates are given in Table 6.3. Average water ingestion rates, in l/year, (from R.G. 1.109 Table E-4) are:

Adult = 370

Child = 260

Infant = 260

Teen = 260

TWDOS_{amt} = total individual water ingestion dose to organ t at PWS m, to the age group a, as described in Section 6.6.1, mrem.

10⁻³ = conversion factor for rem/mrem.

For population doses resulting from fish ingestion the calculation assumes that all fish caught within a 50-mile radius downstream of SQN are consumed by local population. The general equation for calculating population doses, POPF, in man-rem from fish ingestion of all fish caught within a 50-mile radius downstream is:

$$POPF_t = \frac{453.6 \text{ HVST APR}}{10^3 10^3} \sum_{r=1}^4 \sum_{a=1}^3 \frac{TFDOS_{art} POP_a}{FISH_a POP_a} \quad (6.12)$$

where:

POPF_t = total fish ingestion population dose to organ t, man-rem.

HVST = fish harvest for the Tennessee River, 3.04 lbs/acre/y.

APR = size of reach, acres (Table 6.1).

TFDOS_{art} = total fish ingestion dose to organ t for reach r, for the age group a, as described in Section 6.6.2, mrem.

POP_a = fraction of population in each age group a, as given above.

FISH_a = amount of fish ingested by each age group a, kg/y. Average fish ingestion rates (R.G. 1.109 Table E-4) are:

Adult = 6.9

Child = 2.2

Teen = 5.2

453.6 = conversion factor, g/lb.

10³ = conversion factor, mrem/rem.

10³ = conversion factor, g/kg.

For recreation shoreline, the general equation used for calculating the population doses, POPR, in man-rem is:

$$POPR_t = \frac{REQFRA}{10^3 \cdot 8760} \sum_{r=1}^4 TSHDOS_{rt} SHVIS_r HRSVIS_r \quad (6.13)$$

where:

- POPR_t = total recreation population dose for all reaches to organ t, man-rem.
- REQFRA = fraction of yearly recreation which occurs in that quarter, as given in Section 6.6.3.
- TSHDOS_{rt} = total shoreline dose rate for organ t, in reach r, mrem/h.
- SHVIS_r = shoreline visits per year at each reach r, (Table 6.1).
- HRSVIS_r = length of shoreline recreation visit at reach r, 5 hours.
- 10³ = conversion factor, mrem/rem.
- 8760 = conversion factor, hours per year.

6.7 LIQUID DOSE FACTOR EQUATIONS

6.7.1 WATER INGESTION

A_{Wit} (mrem/h per $\mu\text{Ci/ml}$)

$$A_{Wit} = \frac{DF_{Liat} U_{wa} 10^6 10^3}{8760}$$

where:

DF_{Liat} = ingestion dose conversion factor for nuclide i, age group a, organ t, mrem/pCi, (Table 6.4).

U_{wa} = water consumption rate for age group a, L/y, (Table 6.3).

10^6 = conversion factor, pCi/ μCi .

10^3 = conversion factor, ml/l.

8760 = conversion factor, hours per year.

6.7.2 FISH INGESTION

A_{Fit} (mrem/h per $\mu\text{Ci/ml}$)

$$A_{Fit} = \frac{DF_{Liat} U_{fa} B_i 10^6 10^3}{8760}$$

where:

DF_{Liat} = ingestion dose conversion factor for nuclide i, age group a, organ t, mrem/pCi, (Table 6.4).

U_{fa} = fish consumption rate for age group a, kg/y, (Table 6.3).

B_i = bioaccumulation factor for nuclide i, pCi/kg per pCi/L, (Table 6.5).

10^6 = conversion factor, pCi/ μCi .

10^3 = conversion factor, ml/L.

8760 = conversion factor, hours per year.

6.7.3 SHORELINE RECREATION

A_{Rit} (mrem/h per $\mu\text{Ci/ml}$).

$$A_{Rit} = \frac{DF_{Git} K_c M W 10^3 10^6 U}{8760 * 3600 \lambda_i} [1 - \exp(-\lambda_i t_b)]$$

where:

DF_{Git} = dose conversion factor for standing on contaminated ground for nuclide i and organ t (total body and skin), mrem/h per pCi/m², (Table 6.6).

K_c = transfer coefficient from water to shoreline sediment, L/kg-h, (Table 6.3).

M = mass density of sediment, kg/m², (Table 6.3).

W = shoreline width factor, dimensionless, (Table 6.3).

10^3 = conversion factor, ml/L.

10^6 = conversion factor, pCi/ μCi .

3600 = conversion factor, s/h.

λ_i = decay constant for nuclide i, s⁻¹, (Table 6.2).

t_b = time shoreline is exposed to the concentration on the water, s, (Table 6.3).

U = usage factor, 500 h/y.

8760 = conversion factor, hours per year.

Table 6.1 RECEPTORS FOR LIQUID DOSE CALCULATIONS

Tennessee River Reaches Within 50 Mile Radius Downstream of SQN

<u>Name</u>	<u>Beginning TRM</u>	<u>Ending TRM</u>	<u>Size (acres)</u>	<u>Recreation visits/year</u>
Chickamauga Lake below SQN	484	471	9939	5,226,700
Nickajack Lake (Chickamauga Dam to TRM 435)	471	435	6510	240,700
Nickajack Lake (TRM 435 to Nickajack Dam)	435	425	5326	607,600
Guntersville Lake (Nickajack Dam to SQN 50 mi. Radius)	425	400	6766	104,000

Public Water Supplies Within 50 Mile Radius Downstream of SQN

<u>Name</u>	<u>TRM</u>	<u>Population</u>
East Side Utility (Formally C.F. Industries)	473.0	35000
Chattanooga, TN	465.3	224,000
South Pittsburg, TN	418.0	4,898
Bridgeport, AL	413.6	4,650

Table 6.2 RADIONUCLIDE DECAY AND STABLE ELEMENT TRANSFER DATA

(Page 1 of 3)

	Half-Life (minutes)	λ (1/s)	B_{iv}	F_{mi} (cow)	F_{mi} (goat)	F_{fi} (beef)
H-3	6.46E+06	1.79E-09	4.80E+00	1.00E-02	1.70E-01	1.20E-02
C-14	3.01E+09	3.84E-12	5.50E+00	1.20E-02	1.00E-01	3.10E-02
Na-24	9.00E+02	1.28E-05	5.20E-02	4.00E-02	4.00E-02	3.00E-02
P-32	2.06E+04	5.61E-07	1.10E+00	2.50E-02	2.50E-01	4.60E-02
Cr-51	3.99E+04	2.90E-07	2.50E-04	2.20E-03	2.20E-03	2.40E-03
Mn-54	4.50E+05	2.57E-08	2.90E-02	2.50E-04	2.50E-04	8.00E-04
Mn-56	1.55E+02	7.45E-05	2.90E-02	2.50E-04	2.50E-04	8.00E-04
Fe-55	1.42E+06	8.13E-09	6.60E-04	1.20E-03	1.30E-04	1.20E-02
Fe-59	6.43E+04	1.80E-07	6.60E-04	1.20E-03	1.30E-04	1.20E-02
Co-57	3.90E+05	2.96E-08	9.40E-03	1.00E-03	1.00E-03	1.30E-02
Co-58	1.02E+05	1.13E-07	9.40E-03	1.00E-03	1.00E-03	1.30E-02
Co-60	2.77E+06	4.17E-09	9.40E-03	1.00E-03	1.00E-03	1.30E-02
Ni-63	5.27E+07	2.19E-10	1.90E-02	6.70E-03	6.70E-03	5.30E-02
Ni-65	1.51E+02	7.65E-05	1.90E-02	6.70E-03	6.70E-03	5.30E-02
Cu-64	7.62E+02	1.52E-05	1.20E-01	1.40E-02	1.30E-02	9.70E-04
Zn-65	3.52E+05	3.28E-08	4.00E-01	3.90E-02	3.90E-02	3.00E-02
Zn-69m	8.26E+02	1.40E-05	4.00E-01	3.90E-02	3.90E-02	3.00E-02
Zn-69	5.56E+01	2.08E-04	4.00E-01	3.90E-02	3.90E-02	3.00E-02
Br-82	2.12E+03	5.45E-06	7.60E-01	5.00E-02	5.00E-02	2.60E-02
Br-83	1.43E+02	8.08E-05	7.60E-01	5.00E-02	5.00E-02	2.60E-02
Br-84	3.18E+01	3.63E-04	7.60E-01	5.00E-02	5.00E-02	2.60E-02
Br-85	2.87E+00	4.02E-03	7.60E-01	5.00E-02	5.00E-02	2.60E-02
Rb-86	2.69E+04	4.29E-07	1.30E-01	3.00E-02	3.00E-02	3.10E-02
Rb-88	1.78E+01	6.49E-04	1.30E-01	3.00E-02	3.00E-02	3.10E-02
Rb-89	1.54E+01	7.50E-04	1.30E-01	3.00E-02	3.00E-02	3.10E-02
Sr-89	7.28E+04	1.59E-07	1.70E-02	1.40E-03	1.40E-02	6.00E-04
Sr-90	1.50E+07	7.70E-10	1.70E-02	1.40E-03	1.40E-02	6.00E-04
Sr-91	5.70E+02	2.03E-05	1.70E-02	1.40E-03	1.40E-02	6.00E-04
Sr-92	1.63E+02	7.09E-05	1.70E-02	1.40E-03	1.40E-02	6.00E-04
Y-90	3.85E+03	3.00E-06	2.60E-03	1.00E-05	1.00E-05	4.60E-03
Y-91m	4.97E+01	2.32E-04	2.60E-03	1.00E-05	1.00E-05	4.60E-03
Y-91	8.43E+04	1.37E-07	2.60E-03	1.00E-05	1.00E-05	4.60E-03
Y-92	2.12E+02	5.45E-05	2.60E-03	1.00E-05	1.00E-05	4.60E-03
Y-93	6.06E+02	1.91E-05	2.60E-03	1.00E-05	1.00E-05	4.60E-03
Zr-95	9.22E+04	1.25E-07	1.70E-04	5.00E-06	5.00E-06	3.40E-02
Zr-97	1.01E+03	1.14E-05	1.70E-04	5.00E-06	5.00E-06	3.40E-02
Nb-95	5.05E+04	2.29E-07	9.40E-03	2.50E-03	2.50E-03	2.80E-01
Nb-97	7.21E+01	1.60E-04	9.40E-03	2.50E-03	2.50E-03	2.80E-01
Mo-99	3.96E+03	2.92E-06	1.20E-01	7.50E-03	7.50E-03	1.10E-03
Tc-99m	3.61E+02	3.20E-05	2.50E-01	2.50E-02	2.50E-02	4.00E-01
Tc-101	1.42E+01	8.13E-04	2.50E-01	2.50E-02	2.50E-02	4.00E-01
Ru-103	5.67E+04	2.04E-07	5.00E-02	1.00E-06	1.00E-06	4.00E-01
Ru-105	2.66E+02	4.34E-05	5.00E-02	1.00E-06	1.00E-06	4.00E-01
Ru-106	5.30E+05	2.18E-08	5.00E-02	1.00E-06	1.00E-06	4.00E-01

Table 6.2 RADIONUCLIDE DECAY AND STABLE ELEMENT TRANSFER DATA
(Page 2 of 3)

	Half-Life (minutes)	λ (1/s)	B_{iv}	F_{mi} (cow)	F_{mi} (goat)	F_{fi} (beef)
Ag-110m	3.60E+05	3.21E-08	1.50E-01	5.00E-02	5.00E-02	1.70E-02
Sb-124	8.67E+04	1.33E-07	N/A	1.50E-03	1.50E-03	N/A
Sb-125	1.46E+06	7.91E-09	N/A	1.50E-03	1.50E-03	N/A
Sn-125	1.39E+04	8.32E-07	N/A	N/A	N/A	N/A
Te-125m	8.35E+04	1.38E-07	1.30E+00	1.00E-03	1.00E-03	7.70E-02
Te-127m	1.57E+05	7.36E-08	1.30E+00	1.00E-03	1.00E-03	7.70E-02
Te-127	5.61E+02	2.06E-05	1.30E+00	1.00E-03	1.00E-03	7.70E-02
Te-129m	4.84E+04	2.39E-07	1.30E+00	1.00E-03	1.00E-03	7.70E-02
Te-129	6.96E+01	1.66E-04	1.30E+00	1.00E-03	1.00E-03	7.70E-02
Te-131m	1.80E+03	6.42E-06	1.30E+00	1.00E-03	1.00E-03	7.70E-02
Te-131	2.50E+01	4.62E-04	1.30E+00	1.00E-03	1.00E-03	7.70E-02
Te-132	4.69E+03	2.46E-06	1.30E+00	1.00E-03	1.00E-03	7.70E-02
I-130	7.42E+02	1.56E-05	2.00E-02	1.20E-02	4.30E-01	2.90E-03
I-131	1.16E+04	9.96E-07	2.00E-02	1.20E-02	4.30E-01	2.90E-03
I-132	1.38E+02	8.37E-05	2.00E-02	1.20E-02	4.30E-01	2.90E-03
I-133	1.25E+03	9.24E-06	2.00E-02	1.20E-02	4.30E-01	2.90E-03
I-134	5.26E+01	2.20E-04	2.00E-02	1.20E-02	4.30E-01	2.90E-03
I-135	3.97E+02	2.91E-05	2.00E-02	1.20E-02	4.30E-01	2.90E-03
Cs-134	1.08E+06	1.06E-08	1.00E-02	8.00E-03	3.00E-01	1.50E-02
Cs-136	1.90E+04	6.08E-07	1.00E-02	8.00E-03	3.00E-01	1.50E-02
Cs-137	1.59E+07	7.26E-10	1.00E-02	8.00E-03	3.00E-01	1.50E-02
Cs-138	3.22E+01	3.59E-04	1.00E-02	8.00E-03	3.00E-01	1.50E-02
Ba-139	8.31E+01	1.39E-04	5.00E-03	4.00E-04	4.00E-04	3.20E-03
Ba-140	1.84E+04	6.28E-07	5.00E-03	4.00E-04	4.00E-04	3.20E-03
Ba-141	1.83E+01	6.31E-04	5.00E-03	4.00E-04	4.00E-04	3.20E-03
Ba-142	1.07E+01	1.08E-03	5.00E-03	4.00E-04	4.00E-04	3.20E-03
La-140	2.41E+03	4.79E-06	2.50E-03	5.00E-06	5.00E-06	2.00E-04
La-142	9.54E+01	1.21E-04	2.50E-03	5.00E-06	5.00E-06	2.00E-04
Ce-141	4.68E+04	2.47E-07	2.50E-03	1.00E-04	1.00E-04	1.20E-03
Ce-143	1.98E+03	5.83E-06	2.50E-03	1.00E-04	1.00E-04	1.20E-03
Ce-144	4.09E+05	2.82E-08	2.50E-03	1.00E-04	1.00E-04	1.20E-03
Pr-143	1.95E+04	5.92E-07	2.50E-03	5.00E-06	5.00E-06	4.70E-03
Pr-144	1.73E+01	6.68E-04	2.50E-03	5.00E-06	5.00E-06	4.70E-03
Nd-147	1.58E+04	7.31E-07	2.40E-03	5.00E-06	5.00E-06	3.30E-03
W-187	1.43E+03	8.08E-06	1.80E-02	5.00E-04	5.00E-04	1.30E-03
Np-239	3.39E+03	3.41E-06	2.50E-03	5.00E-06	5.00E-06	2.00E-04
Ar-41	1.10E+02	1.05E-04	N/A	N/A	N/A	N/A
Kr-83m	1.10E+02	1.05E-04	N/A	N/A	N/A	N/A
Kr-85m	2.69E+02	4.29E-05	N/A	N/A	N/A	N/A
Kr-85	5.64E+06	2.05E-09	N/A	N/A	N/A	N/A
Kr-87	7.63E+01	1.51E-04	N/A	N/A	N/A	N/A
Kr-88	1.70E+02	6.79E-05	N/A	N/A	N/A	N/A
Kr-89	3.16E+00	3.66E-03	N/A	N/A	N/A	N/A
Kr-90	5.39E-01	2.14E-02	N/A	N/A	N/A	N/A
Xe-131m	1.70E+04	6.79E-07	N/A	N/A	N/A	N/A

Table 6.2 RADIONUCLIDE DECAY AND STABLE ELEMENT TRANSFER DATA
(Page 3 of 3)

	Half-Life (minutes)	λ (1/s)	B_{iv}	F_{mi} (cow)	F_{mi} (goat)	F_{fi} (beef)
Xe-133m	3.15E+03	3.67E-06	N/A	N/A	N/A	N/A
Xe-133	7.55E+03	1.53E-06	N/A	N/A	N/A	N/A
Xe-135m	1.54E+01	7.50E-04	N/A	N/A	N/A	N/A
Xe-135	5.47E+02	2.11E-05	N/A	N/A	N/A	N/A
Xe-137	3.83E+00	3.02E-03	N/A	N/A	N/A	N/A
Xe-138	1.41E+01	8.19E-04	N/A	N/A	N/A	N/A

References:

Half lives for all nuclides: DOE-TIC-11026, "Radioactive Decay Data Tables - A handbook of Decay Data for Application to Radiation Dosimetry and Radiological Assessment," D. C. Kocher, 1981.

Transfer factors for Sb- isotopes are from ORNL 4992, "Methodology for Calculating Radiation Doses from Radioactivity Released to the Environment," March 1976, Table 2-7.

Cow-milk transfer factors for Iodine, Strontium, and Cesium nuclides are from NUREG/CR-1004, Table 3.17.

Goat-milk transfer factors for Iodine nuclides are from NUREG/CR-1004, Table 3.17.

Beef transfer factors for Iron, Copper, Molybdenum, and Cesium nuclides are from NUREG/CR-1004, Table 3.18.

All other nuclides' transfer factors are from Regulatory Guide 1.109, Tables E-1 and E-2.

Table 6.3 DOSE CALCULATION FACTORS
(Page 1 of 2)

Factor	Value	Units	Reference
BR _a (infant)	1400	m ³ /year	ICRP 23
BR _a (child)	5500	m ³ /year	ICRP 23
BR _a (teen)	8000	m ³ /year	ICRP 23
BR _a (adult)	8100	m ³ /year	ICRP 23
f _g	1		TVA Assumption
f _L	1		R. G. 1.109 (Table E-15)
f _p	1		TVA Assumption
f _s	0		TVA Assumption
H	9	g/m ³	TVA Value
K _c	0.072	L/kg-h	R. G. 1.109 (Section 2.C.)
M	40	kg/m ²	R. G. 1.109 (Section 2.C.)
P	240	kg/m ²	R. G. 1.109 (Table E-15)
Q _f (cow)	64	kg/d	NUREG/CR-1004 (Sect. 3.4)
Q _f (goat)	08	kg/d	NUREG/CR-1004 (Sect. 3.4)
r	0.47		NUREG/CR-1004 (Sect. 3.2)
t _b	4.73E+08 (15 years)	seconds	R. G. 1.109 (Table E-15)
t _{cb}	7.78E+06 (90 days)	seconds	SQN FSAR Section 11.3.9.1
t _{csf}	1.56E+07 (180 days)	seconds	SQN FSAR Section 11.3.9.1
t _e	5.18E+06 (60 days)	seconds	R. G. 1.109 (Table E-15)
t _{ep}	2.59E+06 (30 days)	seconds	R. G. 1.109 (Table E-15)
t _{esf}	7.78E+06 (90 days)	seconds	R. G. 1.109 (Table E-15)
t _{fm}	8.64E+04 (1 day)	seconds	SQN FSAR Section 11.3.9.1
t _{hc}	8.64E+04 (1 day)	seconds	NUREG/CR-1004, Table 3.40
t _s	1.12E+06 (13 days)	seconds	NUREG/CR-1004, Table 3.40
t _{sv}	2.38E+07 (275 days)	seconds	SQN FSAR Section 11.3.9.1
U _{am} (infant)	0	kg/year	R. G. 1.109 (Table E-5)
U _{am} (child)	41	kg/year	R. G. 1.109 (Table E-5)
U _{am} (teen)	65	kg/year	R. G. 1.109 (Table E-5)
U _{am} (adult)	110	kg/year	R. G. 1.109 (Table E-5)
U _{ap} (infant)	330	l/year	R. G. 1.109 (Table E-5)
U _{ap} (child)	330	l/year	R. G. 1.109 (Table E-5)
U _{ap} (teen)	400	l/year	R. G. 1.109 (Table E-5)
U _{ap} (adult)	310	l/year	R. G. 1.109 (Table E-5)
U _{fa} (infant)	0	kg/year	R. G. 1.109 (Table E-5)
U _{fa} (child)	6.9	kg/year	R. G. 1.109 (Table E-5)
U _{fa} (teen)	16	kg/year	R. G. 1.109 (Table E-5)

Table 6.3 DOSE CALCULATION FACTORS
(Page 2 of 2)

Factor	Value	Units	Reference
U_{fa} (adult)	21	kg/year	R. G. 1.109 (Table E-5)
U_{fla} (infant)	0	kg/year	R. G. 1.109 (Table E-5)
U_{fla} (child)	26	kg/year	R. G. 1.109 (Table E-5)
U_{fla} (teen)	42	kg/year	R. G. 1.109 (Table E-5)
U_{fla} (adult)	64	kg/year	R. G. 1.109 (Table E-5)
U_{sa} (infant)	0	kg/year	R. G. 1.109 (Table E-5)
U_{sa} (child)	520	kg/year	R. G. 1.109 (Table E-5)
U_{sa} (teen)	630	kg/year	R. G. 1.109 (Table E-5)
U_{sa} (adult)	520	kg/year	R. G. 1.109 (Table E-5)
U_{wa} (infant)	330	L/year	R. G. 1.109 (Table E-5)
U_{wa} (child)	510	L/year	R. G. 1.109 (Table E-5)
U_{wa} (teen)	510	L/year	R. G. 1.109 (Table E-5)
U_{wa} (adult)	730	L/year	R. G. 1.109 (Table E-5)
W	0.3	none	R. G. 1.109 (Table A-2)
Y_f	1.85	kg/m ²	NUREG/CR-1004 (Table 3.4)
Y_p	1.18	kg/m ²	NUREG/CR-1004 (Table 3.3)
Y_{sf}	0.64	kg/m ²	NUREG/CR-1004 (Table 3.3)
Y_{sv}	0.57	kg/m ²	NUREG/CR-1004 (Table 3.4) (value selected is for non-leafy vegetables)
λ_w (iodines)	7.71E-07 (10.4 d half-life)	sec ⁻¹	NUREG/CR-1004 (Table 3.10)
λ_w (particulates)	5.21E-07 (15.4 d half-life)	sec ⁻¹	NUREG/CR-1004 (Table 3.10)

Table 6.4 INGESTION DOSE FACTORS
(mrem/pCi ingested)
(Page 1 of 8)

	ADULT						
	bone	liver	t body	thyroid	kidney	lung	gi-lli
H-3	1.05E-07	1.05E-07	1.05E-07	1.05E-07	1.05E-07	1.05E-07	1.05E-07
C-14	2.84E-06	5.68E-07	5.68E-07	5.68E-07	5.68E-07	5.68E-07	5.68E-07
Na-24	1.70E-06	1.70E-06	1.70E-06	1.70E-06	1.70E-06	1.70E-06	1.70E-06
P-32	1.93E-04	1.20E-05	7.46E-06	0.00E+00	0.00E+00	0.00E+00	2.17E-05
Cr-51	0.00E+00	0.00E+00	2.66E-09	1.59E-09	5.86E-10	3.53E-09	6.69E-07
Mn-54	0.00E+00	4.57E-06	8.72E-07	0.00E+00	1.36E-06	0.00E+00	1.40E-05
Mn-56	0.00E+00	1.15E-07	2.04E-08	0.00E+00	1.46E-07	0.00E+00	3.67E-06
Fe-55	2.75E-06	1.90E-06	4.43E-07	0.00E+00	0.00E+00	1.06E-06	1.09E-06
Fe-59	4.34E-06	1.02E-05	3.91E-06	0.00E+00	0.00E+00	2.85E-06	3.40E-05
Co-57	0.00E+00	1.75E-07	2.91E-07	0.00E+00	0.00E+00	0.00E+00	4.44E-06
Co-58	0.00E+00	7.45E-07	1.67E-06	0.00E+00	0.00E+00	0.00E+00	1.51E-05
Co-60	0.00E+00	2.14E-06	4.72E-06	0.00E+00	0.00E+00	0.00E+00	4.02E-05
Ni-63	1.30E-04	9.01E-06	4.36E-06	0.00E+00	0.00E+00	0.00E+00	1.88E-06
Ni-65	5.28E-07	6.86E-08	3.13E-08	0.00E+00	0.00E+00	0.00E+00	1.74E-06
Cu-64	0.00E+00	8.33E-08	3.91E-08	0.00E+00	2.10E-07	0.00E+00	7.10E-06
Zn-65	4.84E-06	1.54E-05	6.96E-06	0.00E+00	1.03E-05	0.00E+00	9.70E-06
Zn-69	1.03E-08	1.97E-08	1.37E-09	0.00E+00	1.28E-08	0.00E+00	2.96E-09
Zn-69m	1.70E-07	4.08E-07	3.73E-08	0.00E+00	2.47E-07	0.00E+00	2.49E-05
Br-82	0.00E+00	0.00E+00	2.26E-06	0.00E+00	0.00E+00	0.00E+00	2.59E-06
Br-83	0.00E+00	0.00E+00	4.02E-08	0.00E+00	0.00E+00	0.00E+00	5.79E-08
Br-84	0.00E+00	0.00E+00	5.21E-08	0.00E+00	0.00E+00	0.00E+00	4.09E-13
Br-85	0.00E+00	0.00E+00	2.14E-09	0.00E+00	0.00E+00	0.00E+00	0.00E+00
Rb-86	0.00E+00	2.11E-05	9.83E-06	0.00E+00	0.00E+00	0.00E+00	4.16E-06
Rb-88	0.00E+00	6.05E-08	3.21E-08	0.00E+00	0.00E+00	0.00E+00	8.36E-19
Rb-89	0.00E+00	4.01E-08	2.82E-08	0.00E+00	0.00E+00	0.00E+00	2.33E-21
Sr-89	3.08E-04	0.00E+00	8.84E-06	0.00E+00	0.00E+00	0.00E+00	4.94E-05
Sr-90	7.58E-03	0.00E+00	1.86E-03	0.00E+00	0.00E+00	0.00E+00	2.19E-04
Sr-91	5.67E-06	0.00E+00	2.29E-07	0.00E+00	0.00E+00	0.00E+00	2.70E-05
Sr-92	2.15E-06	0.00E+00	9.30E-08	0.00E+00	0.00E+00	0.00E+00	4.26E-05
Y-90	9.62E-09	0.00E+00	2.58E-10	0.00E+00	0.00E+00	0.00E+00	1.02E-04
Y-91m	9.09E-11	0.00E+00	3.52E-12	0.00E+00	0.00E+00	0.00E+00	2.67E-10
Y-91	1.41E-07	0.00E+00	3.77E-09	0.00E+00	0.00E+00	0.00E+00	7.76E-05
Y-92	8.45E-10	0.00E+00	2.47E-11	0.00E+00	0.00E+00	0.00E+00	1.48E-05
Y-93	2.68E-09	0.00E+00	7.40E-11	0.00E+00	0.00E+00	0.00E+00	8.50E-05
Zr-95	3.04E-08	9.75E-09	6.60E-09	0.00E+00	1.53E-08	0.00E+00	3.09E-05
Zr-97	1.68E-09	3.39E-10	1.55E-10	0.00E+00	5.12E-10	0.00E+00	1.05E-04
Nb-95	6.22E-09	3.46E-09	1.86E-09	0.00E+00	3.42E-09	0.00E+00	2.10E-05
Nb-97	5.22E-11	1.32E-11	4.82E-12	0.00E+00	1.54E-11	0.00E+00	4.87E-08
Mo-99	0.00E+00	4.31E-06	8.20E-07	0.00E+00	9.76E-06	0.00E+00	9.99E-06
Tc-99m	2.47E-10	6.98E-10	8.89E-09	0.00E+00	1.06E-08	3.42E-10	4.13E-07
Tc-101	2.54E-10	3.66E-10	3.59E-09	0.00E+00	6.59E-09	1.87E-10	1.10E-21
Ru-103	1.85E-07	0.00E+00	7.97E-08	0.00E+00	7.06E-07	0.00E+00	2.16E-05
Ru-105	1.54E-08	0.00E+00	6.08E-09	0.00E+00	1.99E-07	0.00E+00	9.42E-06
Ru-106	2.75E-06	0.00E+00	3.48E-07	0.00E+00	5.31E-06	0.00E+00	1.78E-04

Table 6.4 INGESTION DOSE FACTORS
(mrem/pCi ingested)
(Page 2 of 8)

	ADULT						
	bone	liver	t body	thyroid	kidney	lung	gi-lli
Ag-110m	1.60E-07	1.48E-07	8.79E-08	0.00E+00	2.91E-07	0.00E+00	6.04E-05
Sb-124	2.80E-06	5.29E-08	1.11E-06	6.79E-09	0.00E-00	2.18E-06	7.95E-05
Sb-125	1.79E-06	2.00E-08	4.26E-07	1.82E-09	0.00E-00	1.38E-06	1.97E-05
Sn-125	8.33E-06	1.68E-07	3.78E-07	1.39E-07	0.00E-00	0.00E-00	1.04E-04
Te-125m	2.68E-06	9.71E-07	3.59E-07	8.06E-07	1.09E-05	0.00E+00	1.07E-05
Te-127m	6.77E-06	2.42E-06	8.25E-07	1.73E-06	2.75E-05	0.00E+00	2.27E-05
Te-127	1.10E-07	3.95E-08	2.38E-08	8.15E-08	4.48E-07	0.00E+00	8.68E-06
Te-129m	1.15E-05	4.29E-06	1.82E-06	3.95E-06	4.80E-05	0.00E+00	5.79E-05
Te-129	3.14E-08	1.18E-08	7.65E-09	2.41E-08	1.32E-07	0.00E+00	2.37E-08
Te-131m	1.73E-06	8.46E-07	7.05E-07	1.34E-06	8.57E-06	0.00E+00	8.40E-05
Te-131	1.97E-08	8.23E-09	6.22E-09	1.62E-08	8.63E-08	0.00E+00	2.79E-09
Te-132	2.52E-06	1.63E-06	1.53E-06	1.80E-06	1.57E-05	0.00E+00	7.71E-05
I-130	7.56E-07	2.23E-06	8.80E-07	1.89E-04	3.48E-06	0.00E+00	1.92E-06
I-131	4.16E-06	5.95E-06	3.41E-06	1.95E-03	1.02E-05	0.00E+00	1.57E-06
I-132	2.03E-07	5.43E-07	1.90E-07	1.90E-05	8.65E-07	0.00E+00	1.02E-07
I-133	1.42E-06	2.47E-06	7.53E-07	3.63E-04	4.31E-06	0.00E+00	2.22E-06
I-134	1.06E-07	2.88E-07	1.03E-07	4.99E-06	4.58E-07	0.00E+00	2.51E-10
I-135	4.43E-07	1.16E-06	4.28E-07	7.65E-05	1.86E-06	0.00E+00	1.31E-06
Cs-134	6.22E-05	1.48E-04	1.21E-04	0.00E+00	4.79E-05	1.59E-05	2.59E-06
Cs-136	6.51E-06	2.57E-05	1.85E-05	0.00E+00	1.43E-05	1.96E-06	2.92E-06
Cs-137	7.97E-05	1.09E-04	7.14E-05	0.00E+00	3.70E-05	1.23E-05	2.11E-06
Cs-138	5.52E-08	1.09E-07	5.40E-08	0.00E+00	8.01E-08	7.91E-09	4.65E-13
Ba-139	9.70E-08	6.91E-11	2.84E-09	0.00E+00	6.46E-11	3.92E-11	1.72E-07
Ba-140	2.03E-05	2.55E-08	1.33E-06	0.00E+00	8.67E-09	1.46E-08	4.18E-05
Ba-141	4.71E-08	3.56E-11	1.59E-09	0.00E+00	3.31E-11	2.02E-11	2.22E-17
Ba-142	2.13E-08	2.19E-11	1.34E-09	0.00E+00	1.85E-11	1.24E-11	3.00E-26
La-140	2.50E-09	1.26E-09	3.33E-10	0.00E+00	0.00E+00	0.00E+00	9.25E-05
La-142	1.28E-10	5.82E-11	1.45E-11	0.00E+00	0.00E+00	0.00E+00	4.25E-07
Ce-141	9.36E-09	6.33E-09	7.18E-10	0.00E+00	2.94E-09	0.00E+00	2.42E-05
Ce-143	1.65E-09	1.22E-06	1.35E-10	0.00E+00	5.37E-10	0.00E+00	4.56E-05
Ce-144	4.88E-07	2.04E-07	2.62E-08	0.00E+00	1.21E-07	0.00E+00	1.65E-04
Pr-143	9.20E-09	3.69E-09	4.56E-10	0.00E+00	2.13E-09	0.00E+00	4.03E-05
Pr-144	3.01E-11	1.25E-11	1.53E-12	0.00E+00	7.05E-12	0.00E+00	4.33E-18
Nd-147	6.29E-09	7.27E-09	4.35E-10	0.00E+00	4.25E-09	0.00E+00	3.49E-05
W-187	1.03E-07	8.61E-08	3.01E-08	0.00E+00	0.00E+00	0.00E+00	2.82E-05
Np-239	1.19E-09	1.17E-10	6.45E-11	0.00E+00	3.65E-10	0.00E+00	2.40E-05

NOTE: The tritium dose factor for bone is assumed to be equal to the total body dose factor.

REFERENCES:

Regulatory Guide 1.109, Table E-11.

Dose Factors for Co-57, Zn-69m, Br-82, Nb-97, Sn-125, Sb-124 and Sb-125 are from NUREG-0172 Age Specific Radiation Dose Commitment Factors for a One Year Chronic Intake, November, 1977, Table 4.

Table 6.4 INGESTION DOSE FACTORS
(mrem/pCi ingested)
(Page 3 of 8)

	TEEN						
	bone	liver	t body	thyroid	kidney	lung	gi-lli
H-3	1.06E-07	1.06E-07	1.06E-07	1.06E-07	1.06E-07	1.06E-07	1.06E-07
C-14	4.06E-06	8.12E-07	8.12E-07	8.12E-07	8.12E-07	8.12E-07	8.12E-07
Na-24	2.30E-06	2.30E-06	2.30E-06	2.30E-06	2.30E-06	2.30E-06	2.30E-06
P-32	2.76E-04	1.71E-05	1.07E-05	0.00E+00	0.00E+00	0.00E+00	2.32E-05
Cr-51	0.00E+00	0.00E+00	3.60E-09	2.00E-09	7.89E-10	5.14E-09	6.05E-07
Mn-54	0.00E+00	5.90E-06	1.17E-06	0.00E+00	1.76E-06	0.00E+00	1.21E-05
Mn-56	0.00E+00	1.58E-07	2.81E-08	0.00E+00	2.00E-07	0.00E+00	1.04E-05
Fe-55	3.78E-06	2.68E-06	6.25E-07	0.00E+00	0.00E+00	1.70E-06	1.16E-06
Fe-59	5.87E-06	1.37E-05	5.29E-06	0.00E+00	0.00E+00	4.32E-06	3.24E-05
Co-57	0.00E+00	2.38E-07	3.99E-07	0.00E+00	0.00E+00	0.00E+00	4.44E-06
Co-58	0.00E+00	9.72E-07	2.24E-06	0.00E+00	0.00E+00	0.00E+00	1.34E-05
Co-60	0.00E+00	2.81E-06	6.33E-06	0.00E+00	0.00E+00	0.00E+00	3.66E-05
Ni-63	1.77E-04	1.25E-05	6.00E-06	0.00E+00	0.00E+00	0.00E+00	1.99E-06
Ni-65	7.49E-07	9.57E-08	4.36E-08	0.00E+00	0.00E+00	0.00E+00	5.19E-06
Cu-64	0.00E+00	1.15E-07	5.41E-08	0.00E+00	2.91E-07	0.00E+00	8.92E-06
Zn-65	5.76E-06	2.00E-05	9.33E-06	0.00E+00	1.28E-05	0.00E+00	8.47E-06
Zn-69	1.47E-08	2.80E-08	1.96E-09	0.00E+00	1.83E-08	0.00E+00	5.16E-08
Zn-69m	2.40E-07	5.66E-07	5.19E-08	0.00E+00	3.44E-07	0.00E+00	3.11E-05
Br-82	0.00E+00	0.00E+00	3.04E-06	0.00E+00	0.00E+00	0.00E+00	0.00E+00
Br-83	0.00E+00	0.00E+00	5.74E-08	0.00E+00	0.00E+00	0.00E+00	0.00E+00
Br-84	0.00E+00	0.00E+00	7.22E-08	0.00E+00	0.00E+00	0.00E+00	0.00E+00
Br-85	0.00E+00	0.00E+00	3.05E-09	0.00E+00	0.00E+00	0.00E+00	0.00E+00
Rb-86	0.00E+00	2.98E-05	1.40E-05	0.00E+00	0.00E+00	0.00E+00	4.41E-06
Rb-88	0.00E+00	8.52E-08	4.54E-08	0.00E+00	0.00E+00	0.00E+00	7.30E-15
Rb-89	0.00E+00	5.50E-08	3.89E-08	0.00E+00	0.00E+00	0.00E+00	8.43E-17
Sr-89	4.40E-04	0.00E+00	1.26E-05	0.00E+00	0.00E+00	0.00E+00	5.24E-05
Sr-90	8.30E-03	0.00E+00	2.05E-03	0.00E+00	0.00E+00	0.00E+00	2.33E-04
Sr-91	8.07E-06	0.00E+00	3.21E-07	0.00E+00	0.00E+00	0.00E+00	3.66E-05
Sr-92	3.05E-06	0.00E+00	1.30E-07	0.00E+00	0.00E+00	0.00E+00	7.77E-05
Y-90	1.37E-08	0.00E+00	3.69E-10	0.00E+00	0.00E+00	0.00E+00	1.13E-04
Y-91m	1.29E-10	0.00E+00	4.93E-12	0.00E+00	0.00E+00	0.00E+00	6.09E-09
Y-91	2.01E-07	0.00E+00	5.39E-09	0.00E+00	0.00E+00	0.00E+00	8.24E-05
Y-92	1.21E-09	0.00E+00	3.50E-11	0.00E+00	0.00E+00	0.00E+00	3.32E-05
Y-93	3.83E-09	0.00E+00	1.05E-10	0.00E+00	0.00E+00	0.00E+00	1.17E-04
Zr-95	4.12E-08	1.30E-08	8.94E-09	0.00E+00	1.91E-08	0.00E+00	3.00E-05
Zr-97	2.37E-09	4.69E-10	2.16E-10	0.00E+00	7.11E-10	0.00E+00	1.27E-04
Nb-95	8.22E-09	4.56E-09	2.51E-09	0.00E+00	4.42E-09	0.00E+00	1.95E-05
Nb-97	7.37E-11	1.83E-11	6.68E-12	0.00E+00	2.14E-11	0.00E+00	4.37E-07
Mo-99	0.00E+00	6.03E-06	1.15E-06	0.00E+00	1.38E-05	0.00E+00	1.08E-05
Tc-99m	3.32E-10	9.26E-10	1.20E-08	0.00E+00	1.38E-08	5.14E-10	6.08E-07
Tc-101	3.60E-10	5.12E-10	5.03E-09	0.00E+00	9.26E-09	3.12E-10	8.75E-17
Ru-103	2.55E-07	0.00E+00	1.09E-07	0.00E+00	8.99E-07	0.00E+00	2.13E-05
Ru-105	2.18E-08	0.00E+00	8.46E-09	0.00E+00	2.75E-07	0.00E+00	1.76E-05
Ru-106	3.92E-06	0.00E+00	4.94E-07	0.00E+00	7.56E-06	0.00E+00	1.88E-04

Table 6.4 INGESTION DOSE FACTORS
(mrem/pCi ingested)
(Page 4 of 8)

	TEEN						
	bone	liver	t body	thyroid	kidney	lung	gi-lli
Ag-110m	2.05E-07	1.94E-07	1.18E-07	0.00E+00	3.70E-07	0.00E+00	5.45E-05
Sb-124	3.87E-06	7.13E-08	1.51E-06	8.78E-09	0.00E-00	3.38E-06	7.80E-05
Sb-125	2.48E-06	2.71E-08	5.80E-07	2.37E-09	0.00E+00	2.18E-06	1.93E-05
Sn-125	1.19E-05	2.37E-07	5.37E-07	1.86E-07	0.00E+00	0.00E+00	1.12E-04
Te-125m	3.83E-06	1.38E-06	5.12E-07	1.07E-06	0.00E+00	0.00E+00	1.13E-05
Te-127m	9.67E-06	3.43E-06	1.15E-06	2.30E-06	3.92E-05	0.00E+00	2.41E-05
Te-127	1.58E-07	5.60E-08	3.40E-08	1.09E-07	6.40E-07	0.00E+00	1.22E-05
Te-129m	1.63E-05	6.05E-06	2.58E-06	5.26E-06	6.82E-05	0.00E+00	6.12E-05
Te-129	4.48E-08	1.67E-08	1.09E-08	3.20E-08	1.88E-07	0.00E+00	2.45E-07
Te-131m	2.44E-06	1.17E-06	9.76E-07	1.76E-06	1.22E-05	0.00E+00	9.39E-05
Te-131	2.79E-08	1.15E-08	8.72E-09	2.15E-08	1.22E-07	0.00E+00	2.29E-09
Te-132	3.49E-06	2.21E-06	2.08E-06	2.33E-06	2.12E-05	0.00E+00	7.00E-05
I-130	1.03E-06	2.98E-06	1.19E-06	2.43E-04	4.59E-06	0.00E+00	2.29E-06
I-131	5.85E-06	8.19E-06	4.40E-06	2.39E-03	1.41E-05	0.00E+00	1.62E-06
I-132	2.79E-07	7.30E-07	2.62E-07	2.46E-05	1.15E-06	0.00E+00	3.18E-07
I-133	2.01E-06	3.41E-06	1.04E-06	4.76E-04	5.98E-06	0.00E+00	2.58E-06
I-134	1.46E-07	3.87E-07	1.39E-07	6.45E-06	6.10E-07	0.00E+00	5.10E-09
I-135	6.10E-07	1.57E-06	5.82E-07	1.01E-04	2.48E-06	0.00E+00	1.74E-06
Cs-134	8.37E-05	1.97E-04	9.14E-05	0.00E+00	6.26E-05	2.39E-05	2.45E-06
Cs-136	8.59E-06	3.38E-05	2.27E-05	0.00E+00	1.84E-05	2.90E-06	2.72E-06
Cs-137	1.12E-04	1.49E-04	5.19E-05	0.00E+00	5.07E-05	1.97E-05	2.12E-06
Cs-138	7.76E-08	1.49E-07	7.45E-08	0.00E+00	1.10E-07	1.28E-08	6.76E-11
Ba-139	1.39E-07	9.78E-11	4.05E-09	0.00E+00	9.22E-11	6.74E-11	1.24E-06
Ba-140	2.84E-05	3.48E-08	1.83E-06	0.00E+00	1.18E-08	2.34E-08	4.38E-05
Ba-141	6.71E-08	5.01E-11	2.24E-09	0.00E+00	4.65E-11	3.43E-11	1.43E-13
Ba-142	2.99E-08	2.99E-11	1.84E-09	0.00E+00	2.53E-11	1.99E-11	9.18E-20
La-140	3.48E-09	1.71E-09	4.55E-10	0.00E+00	0.00E+00	0.00E+00	9.82E-05
La-142	1.79E-10	7.95E-11	1.98E-11	0.00E+00	0.00E+00	0.00E+00	2.42E-06
Ce-141	1.33E-08	8.88E-09	1.02E-09	0.00E+00	4.18E-09	0.00E+00	2.54E-05
Ce-143	2.35E-09	1.71E-06	1.91E-10	0.00E+00	7.67E-10	0.00E+00	5.14E-05
Ce-144	6.96E-07	2.88E-07	3.74E-08	0.00E+00	1.72E-07	0.00E+00	1.75E-04
Pr-143	1.31E-08	5.23E-09	6.52E-10	0.00E+00	3.04E-09	0.00E+00	4.31E-05
Pr-144	4.30E-11	1.76E-11	2.18E-12	0.00E+00	1.01E-11	0.00E+00	4.74E-14
Nd-147	9.38E-09	1.02E-08	6.11E-10	0.00E+00	5.99E-09	0.00E+00	3.68E-05
W-187	1.46E-07	1.19E-07	4.17E-08	0.00E+00	0.00E+00	0.00E+00	3.22E-05
Np-239	1.76E-09	1.66E-10	9.22E-11	0.00E+00	5.21E-10	0.00E+00	2.67E-05

NOTE: The tritium dose factor for bone is assumed to be equal to the total body dose factor.

REFERENCES:

Regulatory Guide 1.109, Table E-12.

Dose Factors for Co-57, Zn-69m, Br-82, Nb-97, Sn-125, Sb-124 and Sb-125 are from NUREG-0172 Age Specific Radiation Dose Commitment Factors for a One Year Chronic Intake, November, 1977, Table 4.

Table 6.4 INGESTION DOSE FACTORS
(mrem/pCi ingested)
(Page 5 of 8)

	CHILD						
	bone	liver	t body	thyroid	kidney	lung	gi-lli
H-3	2.03E-07	2.03E-07	2.03E-07	2.03E-07	2.03E-07	2.03E-07	2.03E-07
C-14	1.21E-05	2.42E-06	2.42E-06	2.42E-06	2.42E-06	2.42E-06	2.42E-06
Na-24	5.80E-06	5.80E-06	5.80E-06	5.80E-06	5.80E-06	5.80E-06	5.80E-06
P-32	8.25E-04	3.86E-05	3.18E-05	0.00E+00	0.00E+00	0.00E+00	2.28E-05
Cr-51	0.00E+00	0.00E+00	8.90E-09	4.94E-09	1.35E-09	9.02E-09	4.72E-07
Mn-54	0.00E+00	1.07E-05	2.85E-06	0.00E+00	3.00E-06	0.00E+00	8.98E-06
Mn-56	0.00E+00	3.34E-07	7.54E-08	0.00E+00	4.04E-07	0.00E+00	4.84E-05
Fe-55	1.15E-05	6.10E-06	1.89E-06	0.00E+00	0.00E+00	3.45E-06	1.13E-06
Fe-59	1.65E-05	2.67E-05	1.33E-05	0.00E+00	0.00E+00	7.74E-06	2.78E-05
Co-57	0.00E+00	4.93E-07	9.98E-07	0.00E+00	0.00E+00	0.00E+00	4.04E-06
Co-58	0.00E+00	1.80E-06	5.51E-06	0.00E+00	0.00E+00	0.00E+00	1.05E-05
Co-60	0.00E+00	5.29E-06	1.56E-05	0.00E+00	0.00E+00	0.00E+00	2.93E-05
Ni-63	5.38E-04	2.88E-05	1.83E-05	0.00E+00	0.00E+00	0.00E+00	1.94E-06
Ni-65	2.22E-06	2.09E-07	1.22E-07	0.00E+00	0.00E+00	0.00E+00	2.56E-05
Cu-64	0.00E+00	2.45E-07	1.48E-07	0.00E+00	5.92E-07	0.00E+00	1.15E-05
Zn-65	1.37E-05	3.65E-05	2.27E-05	0.00E+00	2.30E-05	0.00E+00	6.41E-06
Zn-69	4.38E-08	6.33E-08	5.85E-09	0.00E+00	3.84E-08	0.00E+00	3.99E-06
Zn-69m	7.10E-07	1.21E-06	1.43E-07	0.00E+00	7.03E-07	0.00E+00	3.94E-05
Br-82	0.00E+00	0.00E+00	7.55E-06	0.00E+00	0.00E+00	0.00E+00	0.00E+00
Br-83	0.00E+00	0.00E+00	1.71E-07	0.00E+00	0.00E+00	0.00E+00	0.00E+00
Br-84	0.00E+00	0.00E+00	1.98E-07	0.00E+00	0.00E+00	0.00E+00	0.00E+00
Br-85	0.00E+00	0.00E+00	9.12E-09	0.00E+00	0.00E+00	0.00E+00	0.00E+00
Rb-86	0.00E+00	6.70E-05	4.12E-05	0.00E+00	0.00E+00	0.00E+00	4.31E-06
Rb-88	0.00E+00	1.90E-07	1.32E-07	0.00E+00	0.00E+00	0.00E+00	9.32E-09
Rb-89	0.00E+00	1.17E-07	1.04E-07	0.00E+00	0.00E+00	0.00E+00	1.02E-09
Sr-89	1.32E-03	0.00E+00	3.77E-05	0.00E+00	0.00E+00	0.00E+00	5.11E-05
Sr-90	1.70E-02	0.00E+00	4.31E-03	0.00E+00	0.00E+00	0.00E+00	2.29E-04
Sr-91	2.40E-05	0.00E+00	9.06E-07	0.00E+00	0.00E+00	0.00E+00	5.30E-05
Sr-92	9.03E-06	0.00E+00	3.62E-07	0.00E+00	0.00E+00	0.00E+00	1.71E-04
Y-90	4.11E-08	0.00E+00	1.10E-09	0.00E+00	0.00E+00	0.00E+00	1.17E-04
Y-91m	3.82E-10	0.00E+00	1.39E-11	0.00E+00	0.00E+00	0.00E+00	7.48E-07
Y-91	6.02E-07	0.00E+00	1.61E-08	0.00E+00	0.00E+00	0.00E+00	8.02E-05
Y-92	3.60E-09	0.00E+00	1.03E-10	0.00E+00	0.00E+00	0.00E+00	1.04E-04
Y-93	1.14E-08	0.00E+00	3.13E-10	0.00E+00	0.00E+00	0.00E+00	1.70E-04
Zr-95	1.16E-07	2.55E-08	2.27E-08	0.00E+00	3.65E-08	0.00E+00	2.66E-05
Zr-97	6.99E-09	1.01E-09	5.96E-10	0.00E+00	1.45E-09	0.00E+00	1.53E-04
Nb-95	2.25E-08	8.76E-09	6.26E-09	0.00E+00	8.23E-09	0.00E+00	1.62E-05
Nb-97	2.17E-10	3.92E-11	1.83E-11	0.00E+00	4.35E-11	0.00E+00	1.21E-05
Mo-99	0.00E+00	1.33E-05	3.29E-06	0.00E+00	2.84E-05	0.00E+00	1.10E-05
Tc-99m	9.23E-10	1.81E-09	3.00E-08	0.00E+00	2.63E-08	9.19E-10	1.03E-06
Tc-101	1.07E-09	1.12E-09	1.42E-08	0.00E+00	1.91E-08	5.92E-10	3.56E-09
Ru-103	7.31E-07	0.00E+00	2.81E-07	0.00E+00	1.84E-06	0.00E+00	1.89E-05
Ru-105	6.45E-08	0.00E+00	2.34E-08	0.00E+00	5.67E-07	0.00E+00	4.21E-05
Ru-106	1.17E-05	0.00E+00	1.46E-06	0.00E+00	1.58E-05	0.00E+00	1.82E-04

Table 6.4 INGESTION DOSE FACTORS
(mrem/pCi ingested)
(Page 6 of 8)

	CHILD						
	bone	liver	t body	thyroid	kidney	lung	gi-lli
Ag-110m	5.39E-07	3.64E-07	2.91E-07	0.00E+00	6.78E-07	0.00E+00	4.33E-05
Sb-124	1.11E-05	1.44E-07	3.89E-06	2.45E-08	0.00E+00	6.16E-06	6.94E-05
Sb-125	7.16E-06	5.52E-08	1.50E-06	6.63E-09	0.00E+00	3.99E-06	1.71E-05
Sn-125	3.55E-05	5.35E-07	1.59E-06	5.55E-07	0.00E+00	0.00E+00	1.10E-05
Te-125m	1.14E-05	3.09E-06	1.52E-06	3.20E-06	0.00E+00	0.00E+00	1.10E-05
Te-127m	2.89E-05	7.78E-06	3.43E-06	6.91E-06	8.24E-05	0.00E+00	2.34E-05
Te-127	4.71E-07	1.27E-07	1.01E-07	3.26E-07	1.34E-06	0.00E+00	1.84E-05
Te-129m	4.87E-05	1.36E-05	7.56E-06	1.57E-05	1.43E-04	0.00E+00	5.94E-05
Te-129	1.34E-07	3.74E-08	3.18E-08	9.56E-08	3.92E-07	0.00E+00	8.34E-06
Te-131m	7.20E-06	2.49E-06	2.65E-06	5.12E-06	2.41E-05	0.00E+00	1.01E-04
Te-131	8.30E-08	2.53E-08	2.47E-08	6.35E-08	2.51E-07	0.00E+00	4.36E-07
Te-132	1.01E-05	4.47E-06	5.40E-06	6.51E-06	4.15E-05	0.00E+00	4.50E-05
I-130	2.92E-06	5.90E-06	3.04E-06	6.50E-04	8.82E-06	0.00E+00	2.76E-06
I-131	1.72E-05	1.73E-05	9.83E-06	5.72E-03	2.84E-05	0.00E+00	1.54E-06
I-132	8.00E-07	1.47E-06	6.76E-07	6.82E-05	2.25E-06	0.00E+00	1.73E-06
I-133	5.92E-06	7.32E-06	2.77E-06	1.36E-03	1.22E-05	0.00E+00	2.95E-06
I-134	4.19E-07	7.78E-07	3.58E-07	1.79E-05	1.19E-06	0.00E+00	5.16E-07
I-135	1.75E-06	3.15E-06	1.49E-06	2.79E-04	4.83E-06	0.00E+00	2.40E-06
Cs-134	2.34E-04	3.84E-04	8.10E-05	0.00E+00	1.19E-04	4.27E-05	2.07E-06
Cs-136	2.35E-05	6.46E-05	4.18E-05	0.00E+00	3.44E-05	5.13E-06	2.27E-06
Cs-137	3.27E-04	3.13E-04	4.62E-05	0.00E+00	1.02E-04	3.67E-05	1.96E-06
Cs-138	2.28E-07	3.17E-07	2.01E-07	0.00E+00	2.23E-07	2.40E-08	1.46E-07
Ba-139	4.14E-07	2.21E-10	1.20E-08	0.00E+00	1.93E-10	1.30E-10	2.39E-05
Ba-140	8.31E-05	7.28E-08	4.85E-06	0.00E+00	2.37E-08	4.34E-08	4.21E-05
Ba-141	2.00E-07	1.12E-10	6.51E-09	0.00E+00	9.69E-11	6.58E-10	1.14E-07
Ba-142	8.74E-08	6.29E-11	4.88E-09	0.00E+00	5.09E-11	3.70E-11	1.14E-09
La-140	1.01E-08	3.53E-09	1.19E-09	0.00E+00	0.00E+00	0.00E+00	9.84E-05
La-142	5.24E-10	1.67E-10	5.23E-11	0.00E+00	0.00E+00	0.00E+00	3.31E-05
Ce-141	3.97E-08	1.98E-08	2.94E-09	0.00E+00	8.68E-09	0.00E+00	2.47E-05
Ce-143	6.99E-09	3.79E-06	5.49E-10	0.00E+00	1.59E-09	0.00E+00	5.55E-05
Ce-144	2.08E-06	6.52E-07	1.11E-07	0.00E+00	3.61E-07	0.00E+00	1.70E-04
Pr-143	3.93E-08	1.18E-08	1.95E-09	0.00E+00	6.39E-09	0.00E+00	4.24E-05
Pr-144	1.29E-10	3.99E-11	6.49E-12	0.00E+00	2.11E-11	0.00E+00	8.59E-08
Nd-147	2.79E-08	2.26E-08	1.75E-09	0.00E+00	1.24E-08	0.00E+00	3.58E-05
W-187	4.29E-07	2.54E-07	1.14E-07	0.00E+00	0.00E+00	0.00E+00	3.57E-05
Np-239	5.25E-09	3.77E-10	2.65E-10	0.00E+00	1.09E-09	0.00E+00	2.79E-05

NOTE: The tritium dose factor for bone is assumed to be equal to the total body dose factor.

REFERENCES:

Regulatory Guide 1.109, Table E-13.

Dose Factors for Co-57, Zn-69m, Br-82, Nb-97, Sn-125, Sb-124 and Sb-125 are from NUREG-0172 Age Specific Radiation Dose Commitment Factors for a One Year Chronic Intake, November, 1977, Table 4.

Table 6.4 INGESTION DOSE FACTORS
(mrem/pCi ingested)
(Page 7 of 8)

	INFANT						
	bone	liver	t body	thyroid	kidney	lung	gi-lli
H-3	3.08E-07	3.08E-07	3.08E-07	3.08E-07	3.08E-07	3.08E-07	3.08E-07
C-14	2.37E-05	5.06E-06	5.06E-06	5.06E-06	5.06E-06	5.06E-06	5.06E-06
Na-24	1.01E-05	1.01E-05	1.01E-05	1.01E-05	1.01E-05	1.01E-05	1.01E-05
P-32	1.70E-03	1.00E-04	6.59E-05	0.00E+00	0.00E+00	0.00E+00	2.30E-05
Cr-51	0.00E+00	0.00E+00	1.41E-08	9.20E-09	2.01E-09	1.79E-08	4.11E-07
Mn-54	0.00E+00	1.99E-05	4.51E-06	0.00E+00	4.41E-06	0.00E+00	7.31E-06
Mn-56	0.00E+00	8.18E-07	1.41E-07	0.00E+00	7.03E-07	0.00E+00	7.43E-05
Fe-55	1.39E-05	8.98E-06	2.40E-06	0.00E+00	0.00E+00	4.39E-06	1.14E-06
Fe-59	3.08E-05	5.38E-05	2.12E-05	0.00E+00	0.00E+00	1.59E-05	2.57E-05
Co-57	0.00E+00	1.15E-06	1.87E-06	0.00E+00	0.00E+00	0.00E+00	3.92E-06
Co-58	0.00E+00	3.60E-06	8.98E-06	0.00E+00	0.00E+00	0.00E+00	8.97E-06
Co-60	0.00E+00	1.08E-05	2.55E-05	0.00E+00	0.00E+00	0.00E+00	2.57E-05
Ni-63	6.34E-04	3.92E-05	2.20E-05	0.00E+00	0.00E+00	0.00E+00	1.95E-06
Ni-65	4.70E-06	5.32E-07	2.42E-07	0.00E+00	0.00E+00	0.00E+00	4.05E-05
Cu-64	0.00E+00	6.09E-07	2.82E-07	0.00E+00	1.03E-06	0.00E+00	1.25E-05
Zn-65	1.84E-05	6.31E-05	2.91E-05	0.00E+00	3.06E-05	0.00E+00	5.33E-05
Zn-69	9.33E-08	1.68E-07	1.25E-08	0.00E+00	6.98E-08	0.00E+00	1.37E-05
Zn-69m	1.50E-06	3.06E-06	2.79E-07	0.00E+00	1.24E-06	0.00E+00	4.24E-05
Br-82	0.00E+00	0.00E+00	1.27E-05	0.00E+00	0.00E+00	0.00E+00	0.00E+00
Br-83	0.00E+00	0.00E+00	3.63E-07	0.00E+00	0.00E+00	0.00E+00	0.00E+00
Br-84	0.00E+00	0.00E+00	3.82E-07	0.00E+00	0.00E+00	0.00E+00	0.00E+00
Br-85	0.00E+00	0.00E+00	1.94E-08	0.00E+00	0.00E+00	0.00E+00	0.00E+00
Rb-86	0.00E+00	1.70E-04	8.40E-05	0.00E+00	0.00E+00	0.00E+00	4.35E-06
Rb-88	0.00E+00	4.98E-07	2.73E-07	0.00E+00	0.00E+00	0.00E+00	4.85E-07
Rb-89	0.00E+00	2.86E-07	1.97E-07	0.00E+00	0.00E+00	0.00E+00	9.74E-08
Sr-89	2.51E-03	0.00E+00	7.20E-05	0.00E+00	0.00E+00	0.00E+00	5.16E-05
Sr-90	1.85E-02	0.00E+00	4.71E-03	0.00E+00	0.00E+00	0.00E+00	2.31E-04
Sr-91	5.00E-05	0.00E+00	1.81E-06	0.00E+00	0.00E+00	0.00E+00	5.92E-05
Sr-92	1.92E-05	0.00E+00	7.13E-07	0.00E+00	0.00E+00	0.00E+00	2.07E-04
Y-90	8.69E-08	0.00E+00	2.33E-09	0.00E+00	0.00E+00	0.00E+00	1.20E-04
Y-91m	8.10E-10	0.00E+00	2.76E-11	0.00E+00	0.00E+00	0.00E+00	2.70E-06
Y-91	1.13E-06	0.00E+00	3.01E-08	0.00E+00	0.00E+00	0.00E+00	8.10E-05
Y-92	7.65E-09	0.00E+00	2.15E-10	0.00E+00	0.00E+00	0.00E+00	1.46E-04
Y-93	2.43E-08	0.00E+00	6.62E-10	0.00E+00	0.00E+00	0.00E+00	1.92E-04
Zr-95	2.06E-07	5.02E-08	3.56E-08	0.00E+00	5.41E-08	0.00E+00	2.50E-05
Zr-97	1.48E-08	2.54E-09	1.16E-09	0.00E+00	2.56E-09	0.00E+00	1.62E-04
Nb-95	4.20E-08	1.73E-08	1.00E-08	0.00E+00	1.24E-08	0.00E+00	1.46E-05
Nb-97	4.59E-10	9.79E-11	3.53E-11	0.00E+00	7.65E-11	0.00E+00	3.09E-05
Mo-99	0.00E+00	3.40E-05	6.63E-06	0.00E+00	5.08E-05	0.00E+00	1.12E-05
Tc-99m	1.92E-09	3.96E-09	5.10E-08	0.00E+00	4.26E-08	2.07E-09	1.15E-06
Tc-101	2.27E-09	2.86E-09	2.83E-08	0.00E+00	3.40E-08	1.56E-09	4.86E-07
Ru-103	1.48E-06	0.00E+00	4.95E-07	0.00E+00	3.08E-06	0.00E+00	1.80E-05
Ru-105	1.36E-07	0.00E+00	4.58E-08	0.00E+00	1.00E-06	0.00E+00	5.41E-05
Ru-106	2.41E-05	0.00E+00	3.01E-06	0.00E+00	2.85E-05	0.00E+00	1.83E-04

Table 6.4 INGESTION DOSE FACTORS
(mrem/pCi ingested)
(Page 8 of 8)

	INFANT						
	bone	liver	t body	thyroid	kidney	lung	gi-lli
Ag-110m	9.96E-07	7.27E-07	4.81E-07	0.00E+00	1.04E-06	0.00E+00	3.77E-05
Sb-124	2.14E-05	3.15E-07	6.63E-06	5.68E-08	0.00E+00	1.34E-05	6.60E-05
Sb-125	1.23E-05	1.19E-07	2.53E-06	1.54E-08	0.00E+00	7.72E-06	1.64E-05
Sn-125	7.41E-05	1.38E-06	3.29E-06	1.36E-06	0.00E+00	0.00E+00	1.11E-04
Te-125m	2.33E-05	7.79E-06	3.15E-06	7.84E-06	0.00E+00	0.00E+00	1.11E-05
Te-127m	5.85E-05	1.94E-05	7.08E-06	1.69E-05	1.44E-04	0.00E+00	2.36E-05
Te-127	1.00E-06	3.35E-07	2.15E-07	8.14E-07	2.44E-06	0.00E+00	2.10E-05
Te-129m	1.00E-04	3.43E-05	1.54E-05	3.84E-05	2.50E-04	0.00E+00	5.97E-05
Te-129	2.84E-07	9.79E-08	6.63E-08	2.38E-07	7.07E-07	0.00E+00	2.27E-05
Te-131m	1.52E-05	6.12E-06	5.05E-06	1.24E-05	4.21E-05	0.00E+00	1.03E-04
Te-131	1.76E-07	6.50E-08	4.94E-08	1.57E-07	4.50E-07	0.00E+00	7.11E-06
Te-132	2.08E-05	1.03E-05	9.61E-06	1.52E-05	6.44E-05	0.00E+00	3.81E-05
I-130	6.00E-06	1.32E-05	5.30E-06	1.48E-03	1.45E-05	0.00E+00	2.83E-06
I-131	3.59E-05	4.23E-05	1.86E-05	1.39E-02	4.94E-05	0.00E+00	1.51E-06
I-132	1.66E-06	3.37E-06	1.20E-06	1.58E-04	3.76E-06	0.00E+00	2.73E-06
I-133	1.25E-05	1.82E-05	5.33E-06	3.31E-03	2.14E-05	0.00E+00	3.08E-06
I-134	8.69E-07	1.78E-06	6.33E-07	4.15E-05	1.99E-06	0.00E+00	1.84E-06
I-135	3.64E-06	7.24E-06	2.64E-06	6.49E-04	8.07E-06	0.00E+00	2.62E-06
Cs-134	3.77E-04	7.03E-04	7.10E-05	0.00E+00	1.81E-04	7.42E-05	1.91E-06
Cs-136	4.59E-05	1.35E-04	5.04E-05	0.00E+00	5.38E-05	1.10E-05	2.05E-06
Cs-137	5.22E-04	6.11E-04	4.33E-05	0.00E+00	1.64E-04	6.64E-05	1.91E-06
Cs-138	4.81E-07	7.82E-07	3.79E-07	0.00E+00	3.90E-07	6.09E-08	1.25E-06
Ba-139	8.81E-07	5.84E-10	2.55E-08	0.00E+00	3.51E-10	3.54E-10	5.58E-05
Ba-140	1.71E-04	1.71E-07	8.81E-06	0.00E+00	4.06E-08	1.05E-07	4.20E-05
Ba-141	4.25E-07	2.91E-10	1.34E-08	0.00E+00	1.75E-10	1.77E-10	5.19E-06
Ba-142	1.84E-07	1.53E-10	9.06E-09	0.00E+00	8.81E-11	9.26E-11	7.59E-07
La-140	2.11E-08	8.32E-09	2.14E-09	0.00E+00	0.00E+00	0.00E+00	9.77E-05
La-142	1.10E-09	4.04E-10	9.67E-11	0.00E+00	0.00E+00	0.00E+00	6.86E-05
Ce-141	7.87E-08	4.80E-08	5.65E-09	0.00E+00	1.48E-08	0.00E+00	2.48E-05
Ce-143	1.48E-08	9.82E-06	1.12E-09	0.00E+00	2.86E-09	0.00E+00	5.73E-05
Ce-144	2.98E-06	1.22E-06	1.67E-07	0.00E+00	4.93E-07	0.00E+00	1.71E-04
Pr-143	8.13E-08	3.04E-08	4.03E-09	0.00E+00	1.13E-08	0.00E+00	4.29E-05
Pr-144	2.74E-10	1.06E-10	1.38E-11	0.00E+00	3.84E-11	0.00E+00	4.93E-06
Nd-147	5.53E-08	5.68E-08	3.48E-09	0.00E+00	2.19E-08	0.00E+00	3.60E-05
W-187	9.03E-07	6.28E-07	2.17E-07	0.00E+00	0.00E+00	0.00E+00	3.69E-05
Np-239	1.11E-08	9.93E-10	5.61E-10	0.00E+00	1.98E-09	0.00E+00	2.87E-05

NOTE: The tritium dose factor for bone is assumed to be equal to the total body dose factor.

REFERENCES:

Regulatory Guide 1.109, Table E-14.
Dose Factors for Co-57, Zn-69m, Br-82, Nb-97, Sn-125, Sb-124 and Sb-125 are from NUREG-0172 Age Specific Radiation Dose Commitment Factors for a One Year Chronic Intake, November, 1977, Table 4.

Table 6.5 BIOACCUMULATION FACTORS FOR FRESHWATER FISH
(ρCi/kg per ρCi/L)

H-3	9.0E-01	Y-91m	2.5E+01	I-134	4.0E+01
C-14	4.6E+03	Y-91	2.5E+01	I-135	4.0E+01
Na-24	1.0E+02	Y-92	2.5E+01	Cs-134	1.9E+03
P-32	1.0E+05	Y-93	2.5E+01	Cs-136	1.9E+03
Cr-51	2.0E+02	Zr-95	3.3E+00	Cs-137	1.9E+03
Mn-54	4.0E+02	Zr-97	3.3E+00	Cs-138	1.9E+03
Mn-56	4.0E+02	Nb-95	3.0E+04	Ba-139	4.0E+00
Fe-55	1.0E+02	Nb-97	3.0E+04	Ba-140	4.0E+00
Fe-59	1.0E+02	Mo-99	1.0E+01	Ba-141	4.0E+00
Co-57	5.0E+01	Tc-99m	1.5E+01	Ba-142	4.0E+00
Co-58	5.0E+01	Tc-101	1.5E+01	La-140	2.5E+01
Co-60	5.0E+01	Ru-103	1.0E+01	La-144	2.5E+01
Ni-63	1.0E+02	Ru-105	1.0E+01	Ce-141	1.0E+00
Ni-65	1.0E+02	Ru-106	1.0E+01	Ce-143	1.0E+00
Cu-64	5.0E+01	Ag-110m	2.31E+00	Ce-144	1.0E+00
Zn-65	2.0E+03	Sb-124	1.0E+00	Pr-144	2.5E+01
Zn-69	2.0E+03	Sb-125	1.0E+00	Pr-143	2.5E+01
Zn-69m	2.0E+03	Sn-125	3.0E+03	Nd-147	2.5E+01
Br-82	4.2E+02	Te-125m	4.0E+02	W-187	1.2E+03
Br-83	4.2E+02	Te-127m	4.0E+02	Np-239	1.0E+01
Br-84	4.2E+02	Te-127	4.0E+02		
Br-85	4.2E+02	Te-129m	4.0E+02		
Rb-86	2.0E+03	Te-129	4.0E+02		
Rb-88	2.0E+03	Te-131m	4.0E+02		
Rb-89	2.0E+03	Te-131	4.0E+02		
Sr-89	5.6E+01	Te-132	4.0E+02		
Sr-90	5.6E+01	I-130	4.0E+01		
Sr-91	5.6E+01	I-131	4.0E+01		
Sr-92	5.6E+01	I-132	4.0E+01		
Y-90	2.5E+01	I-133	4.0E+01		

REFERENCES:

Bioaccumulation factors for Ag-110m, Sb-124, Sb-125 and Sn-125 are from ORNL-4992, "A Methodology for Calculating Radiation Doses from Radioactivity Released to the Environment," March 1976, Table 4.12A.

Bioaccumulation factors for Iodine, Cesium, and Strontium nuclides are from NUREG/CR-1004, Table 3.2.4.

All other nuclides' bioaccumulation factors are from Regulatory Guide 1.109, Table A-1.

Table 6.6 EXTERNAL DOSE FACTORS FOR STANDING ON CONTAMINATED GROUND
(mrem/h per pCi/m²)
(Page 1 of 2)

<u>Nuclide</u>	<u>Total Body</u>	<u>Skin</u>
H-3	0.0	0.0
C-14	0.0	0.0
Na-24	2.50E-08	2.90E-08
P-32	0.0	0.0
Cr-51	2.20E-10	2.60E-10
Mn-54	5.80E-09	6.80E-09
Mn-56	1.10E-08	1.30E-08
Fe-55	0.0	0.0
Fe-59	8.00E-09	9.40E-09
Co-57	1.77E-09	2.21E-09
Co-58	7.00E-09	8.20E-09
Co-60	1.70E-08	2.00E-08
Ni-63	0.0	0.0
Ni-65	3.70E-09	4.30E-09
Cu-64	1.50E-09	1.70E-09
Zn-65	4.00E-09	4.60E-09
Zn-69	0.0	0.0
Zn-69m	5.50E-09	6.59E-09
Br-82	3.18E-08	3.90E-08
Br-83	6.40E-11	9.30E-11
Br-84	1.20E-08	1.40E-08
Br-85	0.0	0.0
Rb-86	6.30E-10	7.20E-10
Rb-88	3.50E-09	4.00E-09
Rb-89	1.50E-08	1.80E-08
Sr-89	5.60E-13	6.50E-13
Sr-91	7.10E-09	8.30E-09
Sr-92	9.00E-09	1.00E-08
Y-90	2.20E-12	2.60E-12
Y-91m	3.80E-09	4.40E-09
Y-91	2.40E-11	2.70E-11
Y-92	1.60E-09	1.90E-09
Y-93	5.70E-10	7.80E-10
Zr-95	5.00E-09	5.80E-09
Zr-97	5.50E-09	6.40E-09
Nb-95	5.10E-09	6.00E-09
Nb-97	8.11E-09	1.00E-08
Mo-99	1.90E-09	2.20E-09
Tc-99m	9.60E-10	1.10E-09
Tc-101	2.70E-09	3.00E-09
Ru-103	3.60E-09	4.20E-09
Ru-105	4.50E-09	5.10E-09
Ru-106	1.50E-09	1.80E-09

Table 6.6 EXTERNAL DOSE FACTORS FOR STANDING ON CONTAMINATED GROUND
(mrem/h per pCi/m²)
(Page 2 of 2)

<u>Nuclide</u>	<u>Total Body</u>	<u>Skin</u>
Ag-110m	1.80E-08	2.10E-08
Sb-124	2.17E-08	2.57E-08
Sb-125	5.48E-09	6.80E-09
Sn-125	3.58E-09	4.51E-09
Te-125m	3.50E-11	4.80E-11
Te-127m	1.10E-12	1.30E-12
Te-127	1.00E-11	1.10E-11
Te-129m	7.70E-10	9.00E-10
Te-129	7.10E-10	8.40E-10
Te-131m	8.40E-09	9.90E-09
Te-131	2.20E-09	2.60E-06
Te-132	1.70E-09	2.00E-09
I-130	1.40E-08	1.70E-08
I-131	2.80E-09	3.40E-09
I-132	1.70E-08	2.00E-08
I-133	3.70E-09	4.50E-09
I-134	1.60E-08	1.90E-08
I-135	1.20E-08	1.40E-08
Cs-134	1.20E-08	1.40E-08
Cs-136	1.50E-08	1.70E-08
Cs-137	4.20E-09	4.90E-09
Cs-138	2.10E-08	2.40E-08
Ba-139	2.40E-09	2.70E-09
Ba-140	2.10E-09	2.40E-09
Ba-141	4.30E-09	4.90E-09
Ba-142	7.90E-09	9.00E-09
La-140	1.50E-08	1.70E-08
La-142	1.50E-08	1.80E-08
Ce-141	5.50E-10	6.20E-10
Ce-143	2.20E-09	2.50E-09
Ce-144	3.20E-10	3.70E-10
Pr-143	0.0	0.0
Pr-144	2.00E-10	2.30E-10
Nd-147	1.00E-09	1.20E-09
W-187	3.10E-09	3.60E-09
Np-239	9.50E-10	1.10E-09

REFERENCES:

Regulatory Guide 1.109, Table E-6.
Dose Factors for Co-57, Zn-69m, Br-82, Nb-97, Sn-125, Sb-124 and Sb-125 are from Dose-Rate Conversion Factors for External Exposure to Photon and Electron Radiation from Radionuclides Occurring in Routine Releases from Nuclear Fuel Cycle Facilities, D. C. Kocher, Health Physics Volume 38, April 1980.

Figure 6.1 LIQUID EFFLUENT RELEASE POINTS

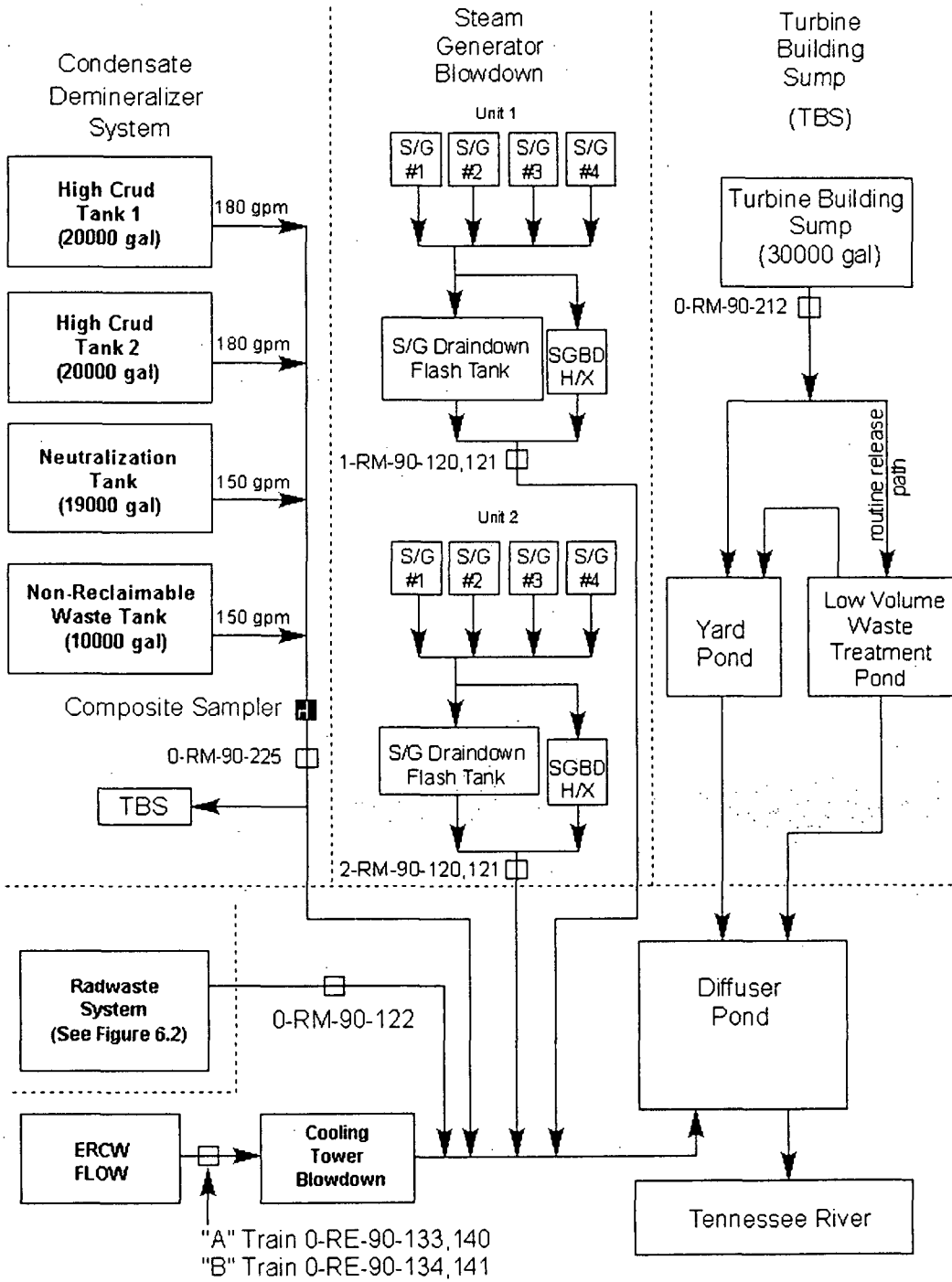
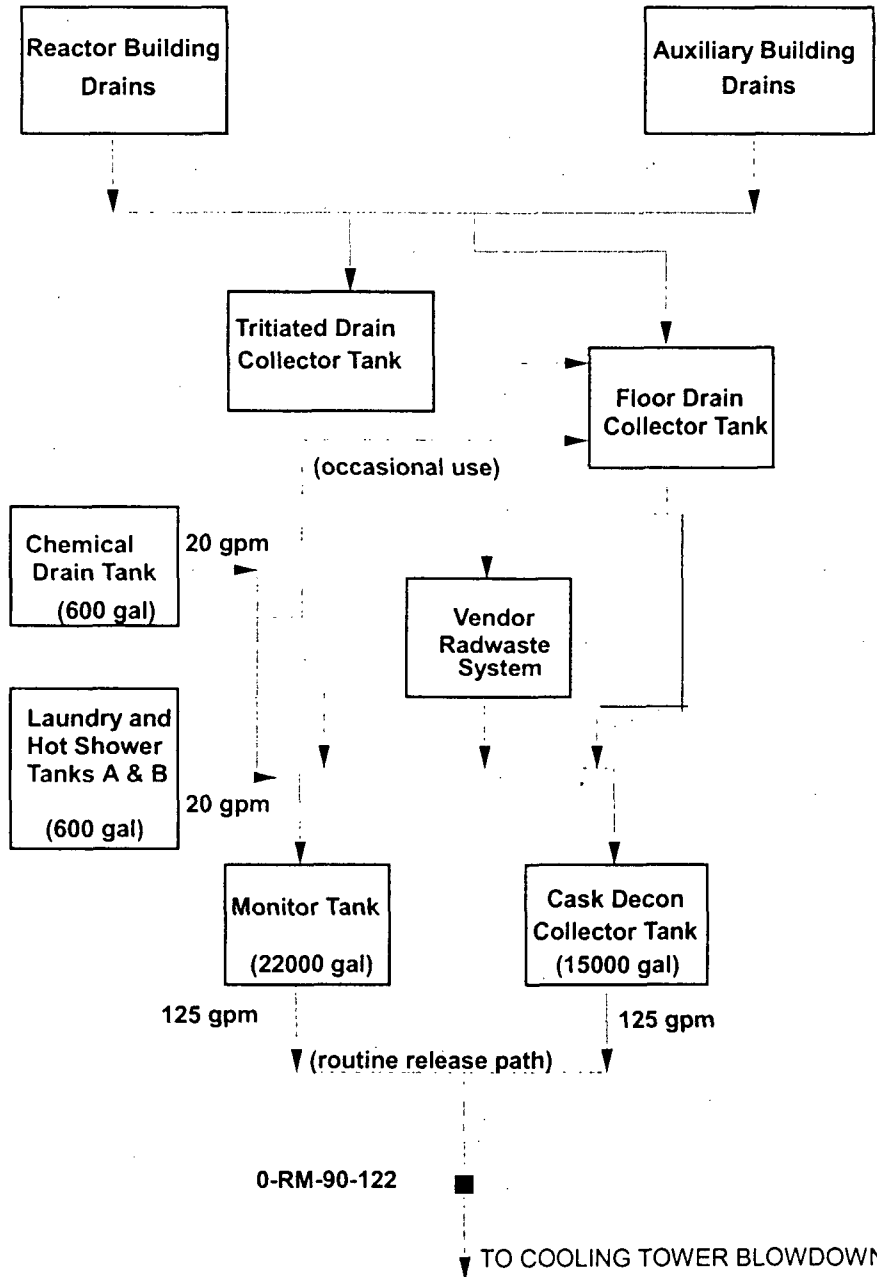

Figure 6.2 LIQUID RADWASTE SYSTEM



SECTION 7.0
GASEOUS EFFLUENTS

SECTION 7.0 GASEOUS EFFLUENTS

RELEASE POINTS DESCRIPTION

There are six major exhaust pathways at Sequoyah Nuclear Plant that are monitored for airborne effluents. These are: a Condenser Vacuum Exhaust for each unit, a Service Building Exhaust, an Auxiliary Building Exhaust and a Shield Building Exhaust for each unit. Figure 7.1 provides an outline of the airborne effluent release and discharge points with associated radiation monitor identifications. All gaseous effluents at Sequoyah are considered ground level for the purpose of evaluating offsite dose and setpoint determination.

Condenser Vacuum Exhaust

The Condenser Vacuum Exhausts (CVEs) are located in the turbine building. The CVE exhaust at a maximum design flow rate of 45 cubic feet per minute. They are monitored for routine releases by radiation monitors 1,2-RM-90-99,119.

Service Building Vent

Various low-level sources exhaust to the Service Building Vent. This exhausts at a total design flow of approximately 11,200 cfm. Only a portion of this total flow (9,000 cfm) originating from the Titration Room, the Chemistry Lab, and the RCA Access Control Area is monitored by radiation monitor 0-RM-90-132.

Auxiliary Building Exhaust (see Figure 7.2 for detail)

The annulus vacuum priming system exhausts through the containment vent to the Auxiliary Building. The Auxiliary Building Exhaust consists of the Auxiliary Building General Exhaust System and the Fuel Handling Exhaust and they cumulatively exhaust at a maximum design flow of 228,000 cfm. The exhaust is monitored by radiation monitor 0-RM-90-101.

Shield Building Vent (see Figure 7.2 for detail)

The Auxiliary Building Gas Treatment System (ABGTS) draws from the Auxiliary Building and exhausts through the Shield Building Vent. There are nine Waste Gas Decay Tanks (WGDTs) that empty into the waste gas header. Either ABGTS or the Emergency Gas Treatment System (EGTS) is run to release a WGDT. Each WGDT has a design capacity of 600 cubic feet at STP and a design release rate of 22.5 cfm. Both the Containment Purge and the Incore Instrument Room Purge from each unit tie into the waste gas header. The Containment Purge exhausts at a maximum of 28,000 cfm and is monitored by radiation monitors 1,2-RM-90-130,131. If the Incore Instrument Room Purge is operating exclusively, it exhausts at 800 cfm. Under emergency conditions, and sometimes during normal operation, the EGTS is used to draw a vacuum in the annulus and exhaust to the Shield Building Vent. Auxiliary Building Isolation starts both the ABGTS and EGTS. The common header exhausts to the Shield Building Exhaust. There is one exhaust for each unit. This exhausts at a maximum design flow of 28,000 cfm and is monitored by radiation monitors 1,2-RM-90-400.

7.1 INSTRUMENT SETPOINTS

Airborne effluent monitor setpoints are determined to ensure that the dose rate at the UNRESTRICTED AREA BOUNDARY does not exceed the dose rate limits given in ODCM Control 1.2.2.1 and to identify unexpected releases.

7.1.1 Release Point Monitor Setpoints (1,2-RM-90-130,-131, 0-RM-90-118)

7.1.1.1 Containment Purge Effluent Monitors (1,2-RM-90-130,-131)

These monitors are set at a cpm value equal to the Technical Specification Limit of $\leq 8.5 \times 10^{-3} \mu\text{Ci/cc}$ as Xe-133 (Technical Specification 3.3.2.1(U1), 3.3.2(U2), Table 3.3-4, and 3.3.3.1, Table 3.3-6). The radiation monitor vacuum setpoint is set at 9 ± 1 in. of vacuum, T/S Limit = $8.5\text{E-}03 \mu\text{Ci/cc}$, monitor efficiency for Xe-133 = $9.08\text{E} + 05 \text{ CPM}/\mu\text{Ci/cc}$, Vacuum Correction = 0.75; therefore the maximum setpoint = $(8.5\text{E-}03) (9.08\text{E}+05)(0.75) = 5800 \text{ CPM}$.

7.1.1.2 Waste Gas Decay Tank Effluent Monitor (0-RM-90-118)

The setpoint for the Waste Gas Decay Tank effluent monitor is routinely set at a Default Setpoint, S_{DEF} . This setpoint uses the site release rate limit and considers the dilution effect of ABGTS during the release process. S_{DEF} for 0-RM-90-118 is 1,882 CPM based on the following:

$$S_{\text{DEF}} = \frac{DR_{\text{LIM}} \cdot 3.28\text{E}+04 \cdot 5.525\text{E-}03}{2.94\text{E}+02 \cdot X/Q \cdot 472 \cdot \text{RR}}$$

Where:

- DR_{LIM} is the site dose rate limit = 500mRem/y
- RR = 50 ft³/min Admin. release rate limit for Waste Gas Decay Tanks
- 3.28E+04 cpm/uCi/cc is the radiation monitor's efficiency
- 5.525E-03 is the max. Dilution flow factor provided by ABGTS (9000cfm)
- X/Q = 6.94E-06 S/M³, Section 7.2.3.1
- 2.94E+02 = Dose Factor for Xe-133 mRem/y/uCi/m³, Table 7.3
- 472 = Conversion Factor, (28317 cc/ft³·min/60 s)

A Maximum Setpoint, S_{MAX} can also be calculated for 0-RM-90-118 based on using the radiation monitor as the primary monitor for the release path. S_{MAX} for 0-RM-90-118 is 31,879 CPM based on the following:

$$S_{\text{MAX}} = \frac{A \cdot DR_{\text{LIM}} \cdot 3.28\text{E}+04}{2.94\text{E}+02 \cdot X/Q \cdot 472 \cdot \text{RR}}$$

Where:

- A = the Dose Rate allocation factor for the shield bldg., 0.0955
- DR_{LIM} is the site dose rate limit = 500mRem/y
- 3.28E+04 cpm/uCi/cc is the radiation monitor's efficiency for Xe-133
- 2.94E+02 = Dose Factor for Xe-133 mRem/y/uCi/m³, Table 7.3
- X/Q = 6.94E-06 S/M³, Section 7.2.3.1
- RR = 50 ft³/min Admin. release rate limit for Waste Gas Decay Tanks
- 472 = Conversion Factor, (28317 cc/ft³·min/60 s)

For each release from a waste gas decay tank, two setpoints are evaluated for the monitor: one based on the expected response of the monitor to the radioactivity in the effluent stream and a calculated expected monitor response setpoint. The expected monitor response is calculated as described below in Equation 7.1. The expected monitor response setpoint is calculated as described below in Equation 7.1a. A comparison is made to verify the expected monitor response and expected monitor response setpoint is less than or equal to the Default Setpoint. If the expected monitor response or expected monitor response setpoint is greater than Default Setpoint it may be temporarily increased but can not exceed the Maximum Setpoint. The calculated setpoints ensures that the release will be stopped if it exceeds any dose rate limits.

Expected Monitor Response, CPM

$$R_{CPM} = B + \sum_i \text{eff}_i C_i \quad (7.1)$$

Where: R_{CPM} = Expected Monitor Response, CPM

B = monitor background, cpm.

eff_i = efficiency factor for the monitor for nuclide i, cpm per $\mu\text{Ci/cc}$.

C_i = measured concentration of nuclide i, $\mu\text{Ci/cc}$.

Expected Monitor Response, uCi/s

$$R_{uCi/s} = B + 472C_i \cdot RR$$

Where : $R_{uCi/s}$ = Expected Release Rate, uCi/s

B = monitor background, uCi/s

472 = Conversion Factor, cc/ft³·m/s

C_i = measured concentration of nuclide i, uCi/cc

RR = Release Rate, ft³/min

Expected Monitor Response Setpoint, CPM or uCi/s (7.1a)

The expected monitor response setpoint S_{er} is calculated for the monitor for each release.

$$S_{er} = X \cdot R$$

where

R = expected monitor response, CPM or uCi/s

X = administrative factor designed to account for expected variations in monitor response and background

The range of values is: $1.0 \leq X \leq 2.0$

7.1.2 Discharge Point Monitor Setpoints (1,2-RE-90-400, 0-RM-90-101, 0-RM-90-132, 1,2-RM-90-99,119)

A normal default setpoint, S_{DEF} is utilized for each discharge point monitor as described below. When release permits are generated, the expected response and expected monitor response setpoint is calculated for the appropriate discharge monitor as described in Section 7.1.1.2. A comparison is made between the two setpoints. If the expected monitor response or expected monitor response setpoint is greater than the default setpoint then the release parameters must be reevaluated. Worse case conditions will require an evaluation of the allocation factors in section 7.1.1.2.

Calculated Default Setpoint

The calculated default setpoint, S_{Def} in cpm (0-101,0-132, & 1,2-99,119), corresponding to the dose rate limit is determined using the following equation:

$$S_{DEF} = \frac{A \cdot DR_{LIM} \cdot Eff \cdot 0.71}{D_{RR} \cdot 472 \cdot 2.94E+02 \cdot X/Q} \quad (7.2)$$

Where:

A = dose rate allocation factor for the release point, dimensionless. The dose rate allocation factors for release points are defined as follows based on design flowrates:

Auxiliary Building	0.7779
Shield Building (ea)	0.0955
Service Building	0.0307
Condenser Vacuum Exhaust (ea)	0.00015

0.71 = safety factor for the monitor, dimensionless. Safety factors for these monitors includes 0.75 for the radiation monitor vacuum correction factor and 0.95 for Xe-133 primary isotope mix.

DR_{lim} = the dose rate limit, 500 mrem/year to the total body for noble gases.

D_{RR} = the design release rate for the release pathway or design approved flow rate.
= DR_{TB} for total body (as described in Section 7.2.3.1).

472 = Conversion Factor, (28317 cc/ft³ · min/60 s).

X/Q = 6.94E-06 S/M³, Section 7.2.3.1.

Eff = Radiation Monitor Efficiency for Xe-133, 0-101,0-132, 1,2-99,119 @ 2.27E+07 CPM/uCi/cc.

2.94E+02 = Dose Factor for Xe-133 mRem/y/uCi/m³, Table 7.3.

The calculated default setpoint, S_{Def} in uCi/s (1,2-400), corresponding to the dose rate limit is determined using the following equation:

$$S_{DEF} = \frac{A \cdot DR_{LIM}}{2.94E+02 \cdot X/Q}$$

7.1.3 Condenser Vacuum Exhaust Vent (1,2-RM-90-99,119)

This discharge point effluent monitor is set to ensure compliance with ODCM Control 1.2.2.1 and to identify the presence of primary to secondary leakage of radioactivity. The default setpoint is determined by Equation 7.2 for Xe-133, and then taking a percentage of this value as the setpoint; or by defining the setpoint as a low value above the normal background. Once a primary to secondary leak is identified, the setpoint on this monitor may be adjusted upward to enable it to be used to identify any further increases in the leak rate but will not be allowed to be set greater than the calculated default value without further evaluation of the allocation factors.

7.2 GASEOUS EFFLUENTS - DOSE RATES

7.2.1 (Deleted)

7.2.2 RELEASE SAMPLING

Prior to each release (excluding an Incore Instrument Room Purge), a grab sample is taken and analyzed to determine the concentration, $\mu\text{Ci/cc}$, of each noble gas nuclide. On at least a weekly basis, filters are analyzed to determine the amount of iodines and particulates released. Composite samples are maintained (as required by Table 2.2-2) to determine the concentration of certain nuclides (Sr-89, Sr-90, and alpha emitters).

For those nuclides whose activities are determined from composite samples the concentrations for the previous composite period will be assumed as the concentration for the next period to perform the calculations in Sections 7.3, 7.4, and 7.5. The actual measured concentrations will be used for the dose calculations described in Section 7.6.

7.2.3 NOBLE GAS DOSE RATES

Dose rates are calculated for total body and skin due to submersion within a cloud of noble gases using a semi-infinite cloud model.

7.2.3.1 Total Body Dose Rate

The dose rate to the total body, DR_{TB} in mrem/year, is calculated using the following equation:

$$DR_{TB} = (\chi/Q) F \sum_i C_i DFB_i \quad (7.3)$$

where

χ/Q = relative concentration, s/m^3 . Relative air concentrations are calculated for the unrestricted area boundary in each of the sixteen sectors as described in Section 7.8.2 from quarterly meteorological data from 1986-1995 (40 quarters). For dose rate calculations, the average of the highest value from the sixteen unrestricted area boundary locations from each of the 40 quarters is used.
= $6.94\text{E-}06 \text{ s/m}^3$ (from Table 7.1).

F = flowrate of effluent stream, cc/s.

C_i = concentration of noble gas nuclide i in effluent stream, $\mu\text{Ci/cc}$.

DFB_i = total body dose factor due to gamma radiation for noble gas nuclide i , mrem/y per $\mu\text{Ci/m}^3$ (Table 7.3).

7.2.3.2 Skin Dose Rate

The dose rate to the skin, DR_S in mrem/year, is calculated using the following equation:

$$DR_S = (\chi/Q) F \sum_i C_i (DFS_i + 1.11 DF_{\gamma i}) \quad (7.4)$$

where

χ/Q = relative concentration, s/m^3 . Relative air concentrations are calculated for the unrestricted area boundary in each of the sixteen sectors as described in Section 7.8.2 from quarterly meteorological data from 1986-1995 (40 quarters). For dose rate calculations, the average of the highest value from the sixteen unrestricted area boundary locations from each of the 40 quarters is used.

= $6.94E-06 s/m^3$ (from Table 7.1).

F = flowrate of effluent stream, cc/s.

C_i = concentration of noble gas nuclide i in effluent stream, $\mu Ci/cc$.

DFS_i = skin dose factor due to beta radiation for noble gas nuclide i, mrem/y per $\mu Ci/m^3$ (Table 7.3).

1.11 = the average ratio of tissue to air energy absorption coefficients, mrem/mrad.

$DF_{\gamma i}$ = dose conversion factor for external gamma for noble gas nuclide i, mrad/y per $\mu Ci/m^3$ (Table 7.3).

7.2.4 I-131, I-133, TRITIUM AND ALL RADIONUCLIDES IN PARTICULATE FORM WITH HALF-LIVES OF GREATER THAN 8 DAYS - ORGAN DOSE RATE

Organ dose rates due to I-131, I-133, Tritium and all radionuclides in particulate form with half-lives of greater than 8 days, DR_{org} in mrem/y, are calculated for all age groups (adult, teen, child, and infant) and all organs (bone, liver, total body, thyroid, kidney, lung, and GI Tract) using the following equation:

$$DR_{org} = F [C_T(\lambda/Q)[R_{IT}+R_{CTP}] + \sum C_i[(\lambda/Q)R_{ii} + (D/Q) [R_{CPI} + RG_i]]] \quad (7.5)$$

where:

F = flowrate of effluent stream, cc/s.

C_T = concentration of tritium in effluent stream, $\mu\text{Ci/cc}$.

λ/Q = relative concentration, s/m^3 . Relative air concentrations are calculated for the unrestricted area boundary in each of the sixteen sectors as described in Section 7.8.2 from quarterly meteorological data from 1986-1995 (40 quarters). For dose rate calculations, the average of the highest value from the sixteen unrestricted area boundary locations from each of the 40 quarters is used.
= $6.94\text{E-}06 \text{ s/m}^3$ (from Table 7.1).

R_{IT} = inhalation dose factor for tritium, mrem/y per $\mu\text{Ci/m}^3$. Dose factor is calculated as described in Section 7.7.13.

R_{CTP} = Grass-cow-milk dose factor for tritium, mrem/y per $\mu\text{Ci/m}^3$. Dose factor is calculated as described in Section 7.7.7.

C_i = concentration of nuclide i in effluent stream, $\mu\text{Ci/cc}$.

R_{ii} = inhalation dose factor for each identified nuclide i, mrem/y per $\mu\text{Ci/m}^3$. Dose factors are calculated as described in Section 7.7.13.

D/Q = relative deposition, $1/\text{m}^2$. Relative deposition is calculated for the unrestricted area boundary in each of the sixteen sectors as described in Section 7.8.3 from quarterly meteorological data from 1986-1995 (40 quarters). For dose rate calculations, the average of the highest value from the sixteen unrestricted area boundary locations from each of the 40 quarters is used.
= $1.30\text{E-}08 \text{ 1/m}^2$ (from Table 7.2).

R_{CPI} = Grass-cow-milk dose factor for each identified nuclide i, $\text{m}^2\text{-mrem/y per } \mu\text{Ci/s}$. Dose factors are calculated as described in Section 7.7.1.

RG_i = ground plane dose factor for each identified nuclide i, $\text{m}^2\text{-mrem/y per } \mu\text{Ci/s}$. Dose factors are calculated as described in Section 7.7.14.

The maximum organ dose rate is selected from among the dose rates calculated for all the organs and all age groups.

7.3 DOSE - NOBLE GASES

Doses to be calculated are gamma and beta air doses due to exposure to an infinite cloud of noble gases. These doses will be calculated from the unrestricted area boundary locations with the highest χ/Q s for each quarter from 1986-1995. Dispersion factors are calculated using the methodology described in Section 7.8.2.

No credit is taken for radioactive decay.

7.3.1 Gamma dose to air

The gamma air dose, D_γ in mrad, is calculated for each release using the following equation:

$$D_\gamma = 1.9E-06 (\chi/Q) \sum_i Q_i DF_{\gamma i} T \quad (7.6)$$

where:

1.9E-06 = conversion factor, y/min.

χ/Q = average of the highest values from the sixteen unrestricted area boundary locations from each quarter, 6.94×10^{-6} s/m³ (from Table 7.1).

Q_i = release rate for nuclide i, $\mu\text{Ci/s}$.

$DF_{\gamma i}$ = dose conversion factor for external gamma for nuclide i (Table 7.3), mrad/y per $\mu\text{Ci/m}^3$.

T = duration of release, min.

The gamma-air dose calculated by this method will be used in the cumulative dose calculations discussed in Section 7.3.3.

7.3.2 Beta dose to air

The beta air dose, D_β in mrad, is calculated for each release using the following equation:

$$D_\beta = 1.9E-06 (\chi/Q) \sum_i Q_i DF_{\beta i} T \quad (7.7)$$

where:

1.9E-06 = conversion factor, y/min.

χ/Q = average of the highest values from the sixteen unrestricted area boundary locations from each quarter, 6.94×10^{-6} s/m³ (from Table 7.1).

Q_i = release rate for nuclide i, $\mu\text{Ci/s}$.

$DF_{\beta i}$ = dose conversion factor for external beta for nuclide i, mrad/y per $\mu\text{Ci/m}^3$ (from Table 7.3).

T = duration of release, min.

The beta-air dose calculated by this method will be used in the cumulative dose calculations discussed in Section 7.3.3.

7.3.3 Cumulative Dose - Noble Gas

Monthly, quarterly and annual sums of all doses are calculated for each release as described below to compare to the limits listed in ODCM Control 1.2.2.2.

For noble gases, cumulative doses are calculated for gamma and beta air doses. Doses due to each release are summed with the doses for all previous release in the quarter or year to obtain cumulative quarterly and annual doses.

7.3.4 Comparison to Limits

The cumulative calendar quarter and calendar year doses are compared to their respective limits once per 31 days to determine compliance.

7.4 DOSE DUE TO I-131, I-133, TRITIUM AND ALL RADIONUCLIDES IN PARTICULATE FORM WITH HALF-LIVES OF GREATER THAN 8 DAYS

7.4.1 Organ dose Calculation

Organ doses due to I-131, I-133, tritium and all radionuclides in particulate form with half-lives of greater than 8 days are calculated for each release for the critical receptors. The critical receptors are defined as the unrestricted area boundary in the sectors with the highest quarterly χ/Q and D/Q for each quarter from 1986-1995. The χ/Q and D/Q are calculated using the methodology in Sections 7.8.2 and 7.8.3 using the historical 1986-1995 meteorological data (Table 7.2). Pathways considered to exist at this location are inhalation, ground plane exposure, grass-cow-milk ingestion, grass-cow-beef ingestion and fresh leafy and stored vegetable ingestion. All age groups are considered (adult, teen, child and infant). Dose factors for these age groups and pathways are calculated as described in Section 7.7. For the ground exposure pathway, which has no age or organ specific dose factors, the total body dose will be added to the internal organ doses for all age groups. No credit is taken for radioactive decay.

The general equation for the calculation of organ dose is:

$$D_{org} = 3.17E-08 T \sum_i \sum_p R_{Pi} [W_p Q_i] \quad (7.8)$$

where:

3.17E-08 = conversion factor, y/s

T = duration of release, s.

R_{Pi} = dose factor for pathway P for each identified nuclide i, m^2 -mrem/y per $\mu Ci/s$ for ground plane, grass-cow-milk, grass-cow-meat, and vegetation pathways, and mrem/y per $\mu Ci/m^3$ for inhalation and tritium ingestion pathways. Equations for calculating these dose factors are given in Section 7.7.

W_p = dispersion factor for the location and pathway,
= χ/Q for the inhalation and tritium ingestion pathways,
= $6.94E-06 s/m^3$.
= D/Q for the food and ground plane pathways,
= $1.30E-08 m^{-2}$

Q_i = release rate for radionuclide i, $\mu Ci/s$

From the four age groups considered, the maximum is determined by comparing all organ doses for all age groups. The age group with the highest single organ dose is selected as the critical age group. The organ doses for the critical age group will be used in the cumulative doses discussed in Section 7.4.2.

7.4.2 Cumulative Doses

Quarterly and annual sums of all doses are calculated for each release as described below to compare to the limits listed in ODCM Control 1.2.2.3.

For maximum organ dose, cumulative quarterly and annual doses are maintained for each of the eight organs considered. The cumulative dose is obtained by summing the doses for each organ of the critical age group (as calculated in Section 7.4.1) as determined for each release with the organ doses for all previous releases in the quarter or year to obtain the cumulative quarterly and annual doses. Thus, the cumulative organ doses will be conservative values, consisting of doses belonging to various age groups depending on the mix of radionuclides. The highest of these cumulative organ doses is used for the comparison to the limits described in ODCM Control 1.2.2.3.

7.4.3 Comparison to Limits

The cumulative calendar quarter and calendar year doses are compared to their respective limits once per 31 days to determine compliance.

7.5 DOSE PROJECTIONS

In accordance with ODCM Surveillance Requirement 2.2.2.4, dose projections will be performed by averaging the two previous month's doses as determined in Section 7.3.3. To determine compliance with the limits, these averages are assigned as the dose projections for the upcoming month.

The projected doses are compared to the limits of ODCM Control 1.2.2.4. The limits are 0.2 mrad per unit for gamma radiation, 0.4 mrad per unit for beta radiation, or 0.3 mrem per unit to any organ.

$$D = \frac{a + b}{2}$$

where:

- D = the 31-day dose projection, mrad
- a = the cumulative gamma, beta, or organ dose for the previous month, mrad
- b = the cumulative gamma, beta, or organ dose for the present month, mrad

If the projected doses exceed any of these limits, the GASEOUS RADWASTE TREATMENT SYSTEM and the VENTILATION EXHAUST TREATMENT SYSTEM shall be used to reduce radioactive materials in gaseous effluents to areas at or beyond the UNRESTRICTED AREA BOUNDARY.

7.5.1 GASEOUS RADWASTE TREATMENT SYSTEM DESCRIPTION

The GASEOUS RADWASTE TREATMENT SYSTEM (GRTS) described below shall be maintained and operated to keep releases ALARA.

A flow diagram for the GRTS is given in Figure 7.3. The system consists of two waste-gas compressor packages, nine gas decay tanks, and the associated piping, valves, and instrumentation. Gaseous wastes are received from the following: degassing of the reactor coolant and purging of the volume control tank prior to a cold shutdown, displacing of cover gases caused by liquid accumulation in the tanks connected to the vent header, and boron recycle process operation.

7.6 QUARTERLY DOSE CALCULATIONS

A complete dose analysis utilizing the total estimated gaseous releases for each calendar quarter will be performed and reported as required in ODCM Administrative Control 5.2. Methodology for this analysis is that which is described in this section using the quarterly release values reported by the plant personnel. All real pathways and receptor locations identified by the most recent land use survey are considered. In addition, actual meteorological data representative of a ground level release for each corresponding calendar quarter will be used. For iodine releases, it is assumed that half the iodine released is in organic form. Organic iodine causes a dose only by inhalation. For cow-milk and beef ingestion doses, the fraction of the time the animals are on stored feed (identified in the survey) is used in the calculation.

The highest organ dose for a real receptor is determined by summing the dose contribution from all identified pathways for each receptor including ground contamination, inhalation, vegetable ingestion (for identified garden locations), cow and/or goat milk ingestion (if a cow or goat is identified for the location), beef ingestion (the beef ingestion dose for the location of highest beef dose for all receptors will be considered the beef dose for all receptors).

7.6.1 NOBLE GAS - GAMMA AIR DOSE

Gamma air doses due to exposure to noble gases, D_γ in mrad, are calculated using the following equation:

$$D_\gamma = \chi_{im} DF_{\gamma i} \quad (7.9)$$

where:

χ_{im} = concentration of nuclide i at location m , $\mu\text{Ci}/\text{m}^3$. Air concentrations are calculated as described by Equation 7.14.

$DF_{\gamma i}$ = dose conversion factor for external gamma for nuclide i , mrad/y per $\mu\text{Ci}/\text{m}^3$ (Table 7.3).

7.6.2 NOBLE GAS - BETA AIR DOSE

Beta air doses due to exposure to noble gases, D_β in mrad, are calculated using the following equation:

$$D_\beta = \chi_{im} DF_{\beta i} \quad (7.10)$$

where:

χ_{im} = concentration of nuclide i at location m , $\mu\text{Ci}/\text{m}^3$. Air concentrations are calculated as described by Equation 7.14.

$DF_{\beta i}$ = dose conversion factor for external beta for nuclide i , mrad/y per $\mu\text{Ci}/\text{m}^3$ (Table 7.3).

7.6.3 RADIOIODINE, PARTICULATE AND TRITIUM - MAXIMUM ORGAN DOSE

Organ doses due to radioiodine, particulate and tritium releases, D_{org} in mrem, are calculated using the following equation:

$$D_{org} = 3.17E-08 \left\{ (\lambda/Q) \sum_P R_{PT} Q_T + \sum_I \left[(D/Q) \sum_P R_{Pi} + (D/Q) R_{gi} + (\lambda/Q) R_{ii} \right] Q_i \right\} \quad (7.11)$$

where:

3.17E-08 = conversion factor, y/s.

λ/Q = Relative concentration for location under consideration, s/m³. Relative concentrations are calculated as described by Equation 7.15.

R_{PT} = ingestion dose factor for pathway P for tritium, m²-mrem/y per μ Ci/s. Ingestion pathways available for consideration are the same as those listed above for R_{Pi} . Equations for calculating ingestion dose factors for tritium are given in Sections 7.7.7 through 7.7.12.

Q_T = adjusted release rate for tritium for location under consideration, μ Ci/s. Calculated in the same manner as Q_i above.

R_{Pi} = ingestion dose factor for pathway P for each identified nuclide i (except tritium), m²-mrem/y per μ Ci/s. Ingestion pathways available for consideration include:

- pasture grass-cow-milk ingestion
- stored feed-cow-milk ingestion
- pasture grass-goat-milk ingestion
- stored feed-goat-milk ingestion
- pasture grass-beef ingestion
- stored feed-beef ingestion
- fresh leafy vegetable ingestion
- stored vegetable ingestion

Equations for calculating these ingestion dose factors are given in Sections 7.7.1 through 7.7.6.
 D/Q = Relative deposition for location under consideration, m⁻². Relative deposition is calculated as described in Equation 7.16.

R_{Gi} = Dose factor for standing on contaminated ground, m²-mrem/y per μ Ci/s. The equation for calculating the ground plane dose factor is given in Section 7.7.14.

R_{ii} = Inhalation dose factor, mrem/y per μ Ci/m³. The equation for calculating the inhalation dose factor is given in Section 7.7.13.

Q_i = adjusted release rate for nuclide i for location under consideration, μ Ci/s. The initial release rate is adjusted to account for decay between the release point and the location, depending on the frequency of wind speeds applicable to that sector. Hence, the adjusted release rate is equal to the actual release rate decayed for an average travel time during the period.

$$Q_i = Q_{i0} \sum_{j=1}^9 f_j \exp(-\lambda_i x/u_j) \quad (7.12)$$

where

Q_{i0} = initial average release rate for nuclide i over the period, μ Ci/s.

f_j = joint relative frequency of occurrence of winds in windspeed class j blowing toward this exposure point, expressed as a fraction.

λ_i = radiological decay constant for nuclide i, s⁻¹.

x = downwind distance, meters.

u_j = midpoint value of wind speed class interval j, m/s.

7.6.4 POPULATION DOSES

For determining population doses to the 50-mile population around the plant, each compass sector is broken down into elements. These elements are defined in Table 7.4. For each of these sector elements, an average dose is calculated, and then multiplied by the population in that sector element. Dispersion factors are calculated for the midpoint of each sector element (see Table 7.4).

For population doses resulting from ingestion, it is conservatively assumed that all food eaten by the average individual is grown locally.

The general equation used for calculating the population dose in a given sector element is:

$$\text{Dose}_{\text{pop}} = \sum_p \text{RATIO}_p * \text{POP}_p * \text{AGE} * 0.001 * \text{DOSE}_p \quad (7.13)$$

where

- RATIO_p = ratio of average to maximum dose for pathway P. (Average ingestion rates are obtained from Regulatory Guide 1.109, Table E-4.)
= 0.5 for submersion and ground exposure pathways, a shielding/occupancy factor.
= 1.0 for the inhalation pathway.
= 0.515, 0.515, 0.5, and 0.355 for milk, for infant, child, teen and adult, respectively. (It is assumed that the ratio of average to maximum infant milk ingestion rates is the same as that for child.)
= 1.0, 0.90, 0.91, 0.86 for beef ingestion, for infant, child, teen and adult, respectively.
= 1.0, 0.38, 0.38, 0.37 for vegetable ingestion, for infant, child, teen and adult, respectively. (It is assumed that the average individual eats no fresh leafy vegetables, only stored vegetables.)
- POP_p = the population of the sector element, persons (Table 7.5).
- AGE = fraction of the population belonging to each age group.
= 0.015, 0.168, 0.153, 0.665 for infant, child, teen and adult, respectively (fractions taken from NUREG/CR-1004, Table 3.39).
- 0.001 = conversion from mrem to rem.
- DOSE_p = the dose for pathway P to the maximum individual at the location under consideration, mrem. For ingestion pathways, this dose is multiplied by an average decay correction to account for decay as the food is moved through the food distribution cycle. This average decay correction, ADC, is defined as follows:

For milk and vegetables, $\text{ADC} = \exp(-\lambda_i t)$

where

λ_i = decay constant for nuclide i, s^{-1} .

t = distribution time for food product under consideration (values from Regulatory Guide 1.109, Table D-1).

= $1.21\text{E}+06$ s (14 d) for vegetables.

= $3.46\text{E}+05$ s (4 d) for milk.

7.6.4 POPULATION DOSES (continued)

$$\text{For meat, ADC} = \frac{\exp(-\lambda_i t) \lambda_i t_{cb}}{1 - \exp(-\lambda_i t_{cb})}$$

where

λ_i = decay constant for nuclide i, s.

t = additional distribution time for meat, over and above the time for slaughter to consumption described in Section 7.7.3, 7 d.

t_{cb} = time to consume a whole beef, as described in Section 7.7.3.

For beef ingestion, the additional factors in the calculation of ADC negate the integration of the dose term over the period during which a whole beef is consumed, for the calculation of population dose. In other words, this assumes that the maximum individual freezes and eats a whole beef, while the average individual buys smaller portions at a time.

Population doses are summed over all sector elements to obtain a total population dose for the 50-mile population.

7.6.5 REPORTING OF DOSES

The calculated quarterly doses and calculated population doses described in this section are reported in the Annual Radiological Effluent Release Report as required by ODCM Administrative Control 5.2.

7.6.6 DOSE TO A MEMBER OF THE PUBLIC INSIDE THE UNRESTRICTED or RESTRICTED AREA BOUNDARY

The Basis for ODCM Control 1.2.2.1 states that for members of the public who may at times be within the UNRESTRICTED or RESTRICTED AREA BOUNDARY, the occupancy factor of that member of the public will usually be sufficiently low to compensate for any increase in the atmospheric dispersion factor above that for the UNRESTRICTED AREA BOUNDARY. This basis also states that examples of calculations for such members of the public will be given in the ODCM.

The determination presented here assumes that the most exposed member of the public will be an adult TVA employee who works just outside the restricted area fence for the entire workyear (2000 hours). Results from onsite Thermoluminescent Dosimeter (TLD) measurements from the years 1990-1992 indicate that the highest onsite external dose was 72.6 mrem. Using this value, subtracting an annual background value of 55 mrem/year, and multiplying by the ratio of the occupancy times, the highest external dose to a MEMBER OF THE PUBLIC inside the UNRESTRICTED AREA BOUNDARY is 4 mrem. Historical records show that the total dose contribution from effluent releases is normally less than 2 mrem. The combination of the measured direct dose (part of which is from effluent releases) and the calculated effluent dose will be below both the 10 CFR Part 20 limit of 100 mrem/year and the 40 CFR Part 190 limit of 25 mrem/year. In addition to this analysis, the dose to this hypothetical member of the public will be determined on an annual basis (using the methodology above) to ensure that the actual dose to any individual is less than 100 mrem/year. The results of this review will be included in the Annual Radiological Effluent Release Report pursuant to ODCM Administrative Control 5.2.

7.7 GASEOUS RELEASES - Dose Factors

7.7.1 PASTURE GRASS-COW/GOAT-MILK INGESTION DOSE FACTORS

(m²-mrem/y per μCi/s)

$$R_{CPi} = 10^6 DFL_{iao} U_{ap} F_{mi} Q_f \exp(-\lambda_i t_{fm}) f_p \left\{ \frac{r(1-\exp(-\lambda_E t_{ep}))}{Y_p \lambda_E} + \frac{B_{iv}(1-\exp(-\lambda_i t_b))}{P \lambda_i} \right\}$$

where:

10^6 = conversion factor, pCi/μCi.

DFL_{iao} = ingestion dose conversion factor for nuclide i, age group a, organ o, mrem/pCi (Table 6.4).

U_{ap} = milk ingestion rate for age group a, L/y.

F_{mi} = transfer factor for nuclide i from animal's feed to milk, d/L (Table 6.2).

Q_f = animal's consumption rate, kg/d.

λ_i = decay constant for nuclide i, s⁻¹ (Table 6.2).

t_{fm} = transport time from milking to receptor, s.

f_p = fraction of time animal spends on pasture, dimensionless.

r = fraction of activity retained on pasture grass, dimensionless.

λ_E = the effective decay constant, due to radioactive decay and weathering, s⁻¹, equal to $\lambda_i + \lambda_w$.

λ_w = weathering decay constant for leaf and plant surfaces, s⁻¹.

t_{ep} = time pasture is exposed to deposition, s.

Y_p = agricultural productivity by unit area of pasture grass, kg/m².

B_{iv} = transfer factor for nuclide i from soil to vegetation, pCi/kg (wet weight of vegetation) per pCi/kg (dry soil).

t_b = time period over which accumulation on the ground is evaluated, s.

P = effective surface density of soil, kg/m².

NOTE: Factors defined above which do not reference a table for their numerical values are given in Table 6.3.

7.7.2 STORED FEED-COW/GOAT-MILK INGESTION DOSE FACTORS

(m²-mrem/y per μCi/s)

$$R_{CSi} = 10^6 \text{ DFL}_{iao} U_{ap} F_{mi} Q_f f_s \exp(-\lambda_i t_{fm}) \frac{(1 - \exp(-\lambda_i t_{csf}))}{t_{csf} \lambda_i} \left\{ \frac{r(1 - \exp(-\lambda_E t_{esf}))}{Y_{sf} \lambda_E} + \frac{B_{iv}(1 - \exp(-\lambda_i t_b))}{P \lambda_i} \right\}$$

where:

- 10⁶ = conversion factor, pCi/μCi.
- DFL_{iao} = ingestion dose conversion factor for nuclide i, age group a, organ o, mrem/pCi (Table 6.4).
- U_{ap} = milk ingestion rate for age group a, L/y.
- F_{mi} = transfer factor for nuclide i from animal's feed to milk, d/L (Table 6.2).
- Q_f = animal's consumption rate, kg/d.
- f_s = fraction of time animal spends on stored feed, dimensionless.
- λ_i = decay constant for nuclide i, s⁻¹ (Table 6.2).
- t_{fm} = transport time from milking to receptor, s.
- t_{csf} = time between harvest of stored feed and consumption by animal, s.
- r = fraction of activity retained on pasture grass, dimensionless.
- λ_E = the effective decay constant, due to radioactive decay and weathering, s⁻¹, equal to λ_i+λ_w.
- λ_w = weathering decay constant for leaf and plant surfaces, s⁻¹.
- t_{esf} = time stored feed is exposed to deposition, s.
- Y_{sf} = agricultural productivity by unit area of stored feed, kg/m².
- B_{iv} = transfer factor for nuclide i from soil to vegetation, pCi/kg (wet weight of vegetation) per pCi/kg (dry soil).
- t_b = time period over which accumulation on the ground is evaluated, s.
- P = effective surface density of soil, kg/m².

NOTE: Factors defined above which do not reference a table for their numerical values are given in Table 6.3.

7.7.3 PASTURE GRASS-BEEF INGESTION DOSE FACTORS

(m²-mrem/y per μCi/s)

$$R_{MPi} = 10^6 \text{DFL}_{iao} U_{am} F_{Fi} Q_F \frac{(1 - \exp(-\lambda_i t_{cb}))}{\lambda_i t_{cb}} \exp(-\lambda_i t_S) f_p \left\{ \frac{r(1 - \exp(-\lambda_E t_{ep}))}{Y_p \lambda_E} + \frac{B_{iv}(1 - \exp(-\lambda_i t_b))}{P \lambda_i} \right\}$$

where:

10⁶ = conversion factor, pCi/μCi.

DFL_{iao} = ingestion dose conversion factor for nuclide i, age group a, organ o, mrem/pCi (Table 6.4).

U_{am} = beef ingestion rate for age group a, kg/y.

F_{Fi} = transfer factor for nuclide i from cow's feed to meat, d/kg (Table 6.2).

Q_F = cow's consumption rate, kg/d.

λ_i = decay constant for nuclide i, s⁻¹ (Table 6.2).

t_{cb} = time for receptor to consume a whole beef, s.

t_S = transport time from slaughter to consumer, s.

f_p = fraction of time cow spends on pasture, dimensionless.

r = fraction of activity retained on pasture grass, dimensionless.

λ_E = the effective decay constant, due to radioactive decay and weathering, s⁻¹, equal to λ_i + λ_w.

λ_w = weathering decay constant for leaf and plant surfaces, s⁻¹.

t_{ep} = time pasture is exposed to deposition, s.

Y_p = agricultural productivity by unit area of pasture grass, kg/m².

B_{iv} = transfer factor for nuclide i from soil to vegetation, pCi/kg (wet weight of vegetation) per pCi/kg (dry soil).

t_b = time over which accumulation on the ground is evaluated, s.

P = effective surface density of soil, kg/m².

NOTE: Factors defined above which do not reference a table for their numerical values are given in Table 6.3.

7.7.4 STORED FEED-BEEF INGESTION DOSE FACTORS

(m²-mrem/y per μCi/s)

$$R_{MSi} = 10^6 \text{DFL}_{iao} U_{am} F_{Fi} Q_F \frac{(1-\exp(-\lambda_i t_{cb}))}{\lambda_i t_{cb}} \exp(-\lambda_i t_s) f_s \frac{(1-\exp(-\lambda_i t_{csf}))}{\lambda_i t_{csf}} \left\{ \frac{r(1-\exp(-\lambda_E t_{esf}))}{Y_{sf} \lambda_E} + \frac{B_{iv}(1-\exp(-\lambda_i t_b))}{P \lambda_i} \right\}$$

where:

- 10⁶ = conversion factor, pCi/μCi.
- DFL_{iao} = ingestion dose conversion factor for nuclide i, age group a, organ o, mrem/pCi (Table 6.4).
- U_{am} = beef ingestion rate for age group a, kg/y.
- F_{Fi} = transfer factor for nuclide i from cow's feed to meat, d/kg (Table 6.2).
- Q_F = cow's consumption rate, kg/d.
- λ_i = decay constant for nuclide i, s⁻¹ (Table 6.2).
- t_{cb} = time for receptor to consume a whole beef, s.
- t_s = transport time from slaughter to consumer, s.
- f_s = fraction of time cow spends on stored feed, dimensionless.
- t_{csf} = time between harvest of stored feed and consumption by cow, s.
- r = fraction of activity retained on pasture grass, dimensionless.
- t_{esf} = time stored feed is exposed to deposition, s.
- Y_{sf} = agricultural productivity by unit area of stored feed, kg/m².
- λ_E = the effective decay constant, due to radioactive decay and weathering, s⁻¹, equal to λ_i+λ_w
- λ_w = weathering decay constant for leaf and plant surfaces, s⁻¹.
- B_{iv} = transfer factor for nuclide i from soil to vegetation, pCi/kg (wet weight of vegetation) per pCi/kg (dry soil).
- t_b = time over which accumulation on the ground is evaluated, s.
- P = effective surface density of soil, kg/m².

NOTE: Factors defined above which do not reference a table for their numerical values are given in Table 6.3.

7.7.5 FRESH LEAFY VEGETABLE INGESTION DOSE FACTORS

(m²-mrem/y per μCi/s)

$$R_{VFi} = 10^6 \text{DFL}_{iao} \exp(-\lambda_i t_{hc}) \text{UFL}_a f_L \left\{ \frac{r(1-e(-\lambda_E t_e))}{Y_F \lambda_E} + \frac{B_{iv}(1-e(-\lambda_i t_b))}{P \lambda_i} \right\}$$

where:

10⁶ = conversion factor, pCi/μCi.

DFL_{iao} = ingestion dose conversion factor for nuclide i, age group a, organ o, mrem/pCi (Table 6.4).

λ_i = decay constant for nuclide i, s⁻¹ (Table 6.2).

t_{hc} = average time between harvest of vegetables and their consumption and/or storage, s.

UFL_a = consumption rate of fresh leafy vegetables by the receptor in age group a, kg/y.

f_L = fraction of fresh leafy vegetables grown locally, dimensionless.

r = fraction of deposited activity retained on vegetables, dimensionless.

λ_E = the effective decay constant, due to radioactive decay and weathering, s⁻¹,

$$= \lambda_i + \lambda_w$$

λ_w = decay constant for removal of activity on leaf and plant surfaces by weathering, s⁻¹.

t_e = exposure time in garden for fresh leafy and/or stored vegetables, s.

Y_F = agricultural yield for fresh leafy vegetables, kg/m².

B_{iv} = transfer factor for nuclide i from soil to vegetables, pCi/kg (wet weight of vegetation) per pCi/kg (dry soil).

t_b = time period over which accumulation on the ground is evaluated, s.

P = effective surface density of soil, kg/m².

NOTE: Factors defined above which do not reference a table for their numerical values are given in Table 6.3.

7.7.6 STORED VEGETABLE INGESTION DOSE FACTORS

m²-mrem/y per μCi/s)

$$R_{vsi} = 10^6 \text{ DFL}_{iao} \exp(-\lambda_i t_{hc}) U_{Sa} f_g \frac{(1 - \exp(-\lambda_i t_{sv}))}{\lambda_i t_{sv}} \left\{ \frac{r(1 - \exp(-\lambda_E t_e))}{Y_{sv} \lambda_E} + \frac{B_{iv}(1 - \exp(-\lambda_i t_b))}{P \lambda_i} \right\}$$

where:

- 10⁶ = conversion factor, pCi/μCi.
- DFL_{iao} = ingestion dose conversion factor for nuclide i, age group a, organ o, mrem/pCi (Table 6.4).
- λ_i = decay constant for nuclide i, s⁻¹ (Table 6.2).
- t_{hc} = average time between harvest of vegetables and their consumption and/or storage, s.
- U_{Sa} = consumption rate of stored vegetables by the receptor in age group a, kg/y.
- f_g = fraction of stored vegetables grown locally, dimensionless.
- t_{sv} = time between storage of vegetables and their consumption, s.
- r = fraction of deposited activity retained on vegetables, dimensionless.
- λ_E = the effective decay constant, due to radioactive decay and weathering, s⁻¹.
= λ_i + λ_w
- λ_w = decay constant for removal of activity on leaf and plant surfaces by weathering, s⁻¹.
- t_e = exposure time in garden for fresh leafy and/or stored vegetables, s.
- Y_{sv} = agricultural yield for stored vegetables, kg/m².
- B_{iv} = transfer factor for nuclide i from soil to vegetables, pCi/kg (wet weight of vegetation) per pCi/kg (dry soil).
- t_b = time period over which accumulation on the ground is evaluated, s.
- P = effective surface density of soil, kg/m².

NOTE: Factors defined above which do not reference a table for their numerical values are given in Table 6.3.

7.7.7 TRITIUM-PASTURE GRASS-COW/GOAT-MILK DOSE FACTOR

(mrem/y per $\mu\text{Ci}/\text{m}^3$)

$$R_{CTP} = 10^3 10^6 \text{DFL}_{Tao} F_{mT} Q_F U_{ap} [0.75(0.5/H)] f_p \exp(-\lambda_T t_{fm})$$

where:

- 10^3 = conversion factor, g/kg.
- 10^6 = conversion factor, pCi/ μCi .
- DFL_{Tao} = ingestion dose conversion factor for tritium for age group a, organ o, mrem/pCi (Table 6.4).
- F_{mT} = transfer factor for tritium from animal's feed to milk, d/L (Table 6.2).
- Q_F = animal's consumption rate, kg/d.
- U_{ap} = milk ingestion rate for age group a, L/y.
- 0.75 = the fraction of total feed that is water.
- 0.5 = the ratio of the specific activity of the feed grass water to the atmospheric water.
- H = absolute humidity of the atmosphere, g/m^3 .
- f_p = fraction of time animal spends on pasture, dimensionless.
- λ_T = decay constant for tritium, s^{-1} (Table 6.2).
- t_{fm} = transport time from milking to receptor, s.

7.7.8 TRITIUM-STORED FEED-COW/GOAT-MILK DOSE FACTOR

(mrem/y per $\mu\text{Ci}/\text{m}^3$)

$$R_{CTS} = 10^3 10^6 \text{DFL}_{Tao} F_{FT} Q_F U_{am} [0.75(0.5/H)] f_S \exp(-\lambda_T t_S) \frac{(1 - \exp(-\lambda_T t_{csf}))}{\lambda_T t_{csf}} \frac{(1 - \exp(-\lambda_T t_{cb}))}{\lambda_T t_{cb}}$$

where:

- 10^3 = conversion factor, g/kg.
- 10^6 = conversion factor, pCi/ μCi .
- DFL_{Tao} = ingestion dose conversion factor for H-3 for age group a, organ o, mrem/pCi (Table 6.4).
- F_{FT} = transfer factor for H-3 from cow's feed to meat, d/kg (Table 6.2).
- Q_F = cow's consumption rate, kg/d.
- U_{am} = meat ingestion rate for age group a, kg/y.
- 0.75 = the fraction of total feed that is water.
- 0.5 = the ratio of the specific activity of the feed grass water to the atmospheric water.
- H = absolute humidity of the atmosphere, g/m^3 .
- f_S = fraction of time cow spends on stored feed, dimensionless.
- λ_T = decay constant for tritium, s^{-1} (Table 6.2).
- t_S = transport time from slaughter to consumer, s.
- t_{csf} = time to consume stored feed, s.
- t_{cb} = time for receptor to consume a whole beef, s.

NOTE: Factors defined above which do not reference a table for their numerical values are given in Table 6.3.

7.7.9 TRITIUM-PASTURE GRASS-BEEF DOSE FACTOR

(mrem/y per $\mu\text{Ci}/\text{m}^3$)

$$R_{\text{MTP}} = 10^3 10^6 \text{DFL}_{\text{Tao}} F_{\text{FT}} Q_{\text{F}} U_{\text{am}} [0.75(0.5/H)] f_{\text{p}} \exp(-\lambda_{\text{T}} t_{\text{S}}) \frac{(1-\exp(-\lambda_{\text{T}} t_{\text{ep}}))}{\lambda_{\text{T}} t_{\text{ep}}} \frac{(1-\exp(-\lambda_{\text{T}} t_{\text{cb}}))}{\lambda_{\text{T}} t_{\text{cb}}}$$

where:

- 10^3 = conversion factor, g/kg.
- 10^6 = conversion factor, pCi/ μCi .
- DFL_{Tao} = ingestion dose conversion factor for H-3 for age group a, organ o, mrem/pCi (Table 6.4).
- F_{FT} = transfer factor for H-3 from cow's feed to meat, d/kg (Table 6.2).
- Q_{F} = cow's consumption rate, kg/d.
- U_{am} = beef ingestion rate for age group a, kg/y.
- 0.75 = the fraction of total feed that is water.
- 0.5 = the ratio of the specific activity of the feed grass water to the atmospheric water.
- H = absolute humidity of the atmosphere, g/m^3 .
- f_{p} = fraction of time cow spends on pasture, dimensionless.
- λ_{T} = decay constant for tritium, s^{-1} (Table 6.2).
- t_{S} = transport time from slaughter to consumer, s.
- t_{ep} = time pasture is exposed to deposition, s.
- t_{cb} = time for receptor to consume a whole beef, s.

7.7.10 TRITIUM-STORED FEED-BEEF DOSE FACTOR

(mrem/y per $\mu\text{Ci}/\text{m}^3$)

$$R_{\text{MST}} = 10^3 10^6 \text{DFL}_{\text{Tao}} F_{\text{FT}} Q_{\text{F}} U_{\text{am}} [0.75(0.5/H)] f_{\text{S}} \exp(-\lambda_{\text{T}} t_{\text{S}}) \frac{(1-\exp(-\lambda_{\text{T}} t_{\text{csf}}))}{\lambda_{\text{T}} t_{\text{csf}}} \frac{(1-\exp(-\lambda_{\text{T}} t_{\text{cb}}))}{\lambda_{\text{T}} t_{\text{cb}}}$$

where:

- 10^3 = conversion factor, g/kg.
- 10^6 = conversion factor, pCi/ μCi .
- DFL_{Tao} = ingestion dose conversion factor for H-3 for age group a, organ o, mrem/pCi (Table 6.4).
- F_{FT} = transfer factor for H-3 from cow's feed to meat, d/kg (Table 6.2).
- Q_{F} = cow's consumption rate, kg/d.
- U_{am} = beef ingestion rate for age group a, kg/y.
- 0.75 = the fraction of total feed that is water.
- 0.5 = the ratio of the specific activity of the feed grass water to the atmospheric water.
- H = absolute humidity of the atmosphere, g/m^3 .
- f_{S} = fraction of time cow spends on stored feed, dimensionless.
- λ_{T} = decay constant for tritium, s^{-1} (Table 6.2).
- t_{S} = transport time from slaughter to consumer, s.
- t_{csf} = time to consume stored feed, s.
- t_{cb} = time for receptor to consume a whole beef, s.

NOTE: Factors defined above which do not reference a table for their numerical values are given in Table 6.3.

7.7.11 TRITIUM-FRESH LEAFY VEGETABLES DOSE FACTOR
(mrem/y per $\mu\text{Ci}/\text{m}^3$)

$$R_{\text{VTF}} = 10^3 10^6 \text{DFL}_{\text{TaO}} [0.75(0.5/H)] U_{\text{FLa}} f_L \exp(-\lambda_T t_{\text{hc}})$$

where:

10^3 = conversion factor, g/kg.

10^6 = conversion factor, pCi/ μCi .

DFL_{TaO} = ingestion dose conversion factor for tritium for age group a, organ o, mrem/pCi (Table 6.4).

0.75 = the fraction of total vegetation that is water.

0.5 = the ratio of the specific activity of the vegetables water to the atmospheric water.

H = absolute humidity of the atmosphere, g/m^3 .

U_{FLa} = consumption rate of fresh leafy vegetables by the receptor in age group a, kg/y.

f_L = fraction of fresh leafy vegetables grown locally, dimensionless.

λ_T = decay constant for tritium, s^{-1} (Table 6.2).

t_{hc} = time between harvest of vegetables and their consumption and/or storage, s.

NOTE: Factors defined above which do not reference a table for their numerical values are given in Table 6.3.

7.7.12 TRITIUM-STORED VEGETABLES DOSE FACTOR

(mrem/year per $\mu\text{Ci}/\text{m}^3$)

$$R_{\text{VTS}} = 10^3 10^6 \text{DFL}_{\text{TaO}} [0.75(0.5/H)] U_{\text{Sa}} f_g \frac{(1 - \exp(-\lambda_{\text{T}} t_{\text{Sv}}))}{\lambda_{\text{T}} t_{\text{Sv}}} \exp(-\lambda_{\text{T}} t_{\text{hc}})$$

where:

10^3 = conversion factor, g/kg.

10^6 = conversion factor, pCi/ μCi .

DFL_{TaO} = ingestion dose conversion factor for tritium for age group a, organ o, mrem/pCi (Table 6.4).

0.75 = the fraction of total vegetation that is water.

0.5 = the ratio of the specific activity of the vegetation water to the atmospheric water.

H = absolute humidity of the atmosphere, g/ m^3 .

U_{Sa} = consumption rate of stored vegetables by the receptor in age group a, kg/y.

f_g = fraction of stored vegetables grown locally, dimensionless.

λ_{T} = decay constant for tritium, s^{-1} (Table 6.2).

t_{Sv} = time between harvest of stored vegetables and their consumption and/or storage, s.

t_{hc} = time between harvest of vegetables and their storage, s.

7.7.13 INHALATION DOSE FACTORS

(mrem/y per $\mu\text{Ci}/\text{m}^3$)

$$R_{\text{I}} = \text{DFA}_{\text{iao}} \text{BR}_{\text{a}} 10^6$$

where:

DFA_{iao} = inhalation dose conversion factor for nuclide i, age group a and organ o, mrem/pCi (Table 7.6).

BR_{a} = breathing rate for age group a, m^3/y (Table 6.3).

10^6 = conversion factor, pCi/ μCi .

7.7.14 GROUND PLANE DOSE FACTORS

(m^2 -mrem/y per $\mu\text{Ci}/\text{s}$)

$$R_{\text{Gi}} = \text{DFG}_{\text{io}} 1/\lambda_i 10^6 8760 [1 - \exp(-\lambda_i t_b)]$$

where:

DFG_{io} = dose conversion factor for standing on contaminated ground for nuclide i and organ o (total body and skin), mrem/hr per pCi/ m^2 (Table 6.6).

λ_i = decay constant of nuclide i, s^{-1} (Table 6.2).

10^6 = conversion factor, pCi/ μCi .

8760 = conversion factor, h/y.

t_b = time period over which the ground accumulation is evaluated, s (Table 6.3).

7.8 DISPERSION METHODOLOGY

Dispersion factors are calculated for radioactive effluent releases using hourly average meteorological data consisting of wind speed and direction measurements at 10m and temperature measurements at 9m and 46m.

A sector-average dispersion equation consistent with Regulatory Guide 1.111 is used. The dispersion model considers plume depletion (using information from Figure 7.4), and building wake effects. Terrain effects on dispersion are not considered.

Hourly average meteorological data are expressed as a joint-frequency distribution of wind speed, wind direction, and atmospheric stability. A joint-frequency distribution for each quarter from 1986-1995 is used for calculations described in Section 7.2, 7.3, 7.4, and 7.5. A joint-frequency distribution using the actual hourly-average meteorological data is used for calculations described in Section 7.6.

The wind speed classes that are used are as follows:

<u>Number</u>	<u>Range (m/s)</u>	<u>Midpoint (m/s)</u>
1	<0.3	0.13
2	0.3-0.6	0.45
3	0.7-1.5	1.10
4	1.6-2.4	1.99
5	2.5-3.3	2.88
6	3.4-5.5	4.45
7	5.6-8.2	6.91
8	8.3-10.9	9.59
9	>10.9	10.95

The stability classes that will be used are the standard A through G classifications. The stability classes 1-7 will correspond to A=1, B=2, ..., G=7.

7.8.1 AIR CONCENTRATION

Air concentrations of nuclides at downwind locations are calculated using the following equation:

$$\chi_i = \sum_{j=1}^9 \sum_{k=1}^7 (2/\pi)^{1/2} \frac{f_{jk} Q_i p}{\sum_{zk} u_j (2\pi x/n)} \exp(-\lambda_i x/u_j) \quad (7.14)$$

where

- f_{jk} = joint relative frequency of occurrence of winds in windspeed class j, stability class k, blowing toward this exposure point, expressed as a fraction.
- Q_i = release rate of radionuclide i, $\mu\text{Ci/s}$.
- p = fraction of radionuclide remaining in plume (Figure 7.4).

- Σ_{zk} = vertical dispersion coefficient for stability class k which includes a building wake adjustment,
 $= (\sigma_{zk}^2 + cA/\pi)^{1/2}$,
or $= (3)^{1/2} \sigma_{zk}$, whichever is smaller.
where
 σ_{zk} is the vertical dispersion coefficient for stability class k (m) (Figure 7.5),
c is a building shape factor (c=0.5),
A is the minimum building cross-sectional area (1800 m²).
- u_j = midpoint value of wind speed class interval j, m/s.
x = downwind distance, m.
n = number of sectors, 16.
 λ_i = radioactive decay coefficient of radionuclide i, s⁻¹
 $2\pi x/n$ = sector width at point of interest, m.

7.8.2 RELATIVE CONCENTRATION

Relative concentrations of nuclides at downwind locations are calculated using the following equation:

$$\chi/Q = \sum_{j=1}^9 \sum_{k=1}^7 (2/\pi)^{1/2} \frac{f_{jk}}{\Sigma_{zk} u_j (2\pi x/n)} \quad (7.15)$$

where

- f_{jk} = joint relative frequency of occurrence of winds in windspeed class j, stability class k, blowing toward this exposure point, expressed as a fraction.
 Σ_{zk} = vertical dispersion coefficient for stability class k which includes a building wake adjustment,
 $= (\sigma_{zk}^2 + cA/\pi)^{1/2}$,
or $= (3)^{1/2} \sigma_{zk}$, whichever is smaller.
where
 σ_{zk} is the vertical dispersion coefficient for stability class k (m) (Figure 7.5),
c is a building shape factor (c=0.5),
A is the minimum building cross-sectional area (1800 m²).
- u_j = midpoint value of wind speed class interval j, m/s.
x = downwind distance, m.
n = number of sectors, 16.
 $2\pi x/n$ = sector width at point of interest, m.

7.8.3 RELATIVE DEPOSITION

Relative deposition of nuclides at downwind locations is calculated using the following equation:

$$D/Q = \sum_{j=1}^9 \sum_{k=1}^7 \frac{f_{jk} DR}{(2\pi x/n)} \quad (7.16)$$

where

f_{jk} = joint relative frequency of occurrence of winds in windspeed class j and stability class k, blowing toward this exposure point, expressed as a fraction.

DR = relative deposition rate, m^{-1} (from Figure 7.6).

x = downwind distance, m.

n = number of sectors, 16.

$2\pi x/n$ = sector width at point of interest, m.

Table 7.1 Sequoyah Maximum Quarterly χ/Q (1986-1995) Sorted by Quarter

QUARTER	YEAR	MAXIMUM SECTOR	DISTANCE (METERS)	$\chi/Q(10^{-6} S/M^3)$
1	1986	NNW	730	5.88
2	1986	NNW	730	6.99
3	1986	N	950	5.66
4	1986	SSW	1840	9.01
1	1987	SSW	1840	6.87
2	1987	N	950	10.00
3	1987	S	1570	7.55
4	1987	SSW	1840	9.45
1	1988	N	950	4.11
2	1988	SSW	1840	6.00
3	1988	N	950	6.05
4	1988	SSW	1840	5.30
1	1989	NNW	730	5.58
2	1989	N	950	5.97
3	1989	S	1570	7.48
4	1989	N	950	6.67
1	1990	N	950	5.38
2	1990	N	950	4.47
3	1990	SSW	1840	6.22
4	1990	NNW	730	6.50
1	1991	SSW	1840	4.41
2	1991	N	950	7.63
3	1991	S	1570	6.76
4	1991	NNW	730	5.91
1	1992	NW	660	6.83
2	1992	N	950	7.05
3	1992	N	950	6.37
4	1992	SSW	1840	6.19
1	1993	SSW	1840	9.15
2	1993	N	950	9.59
3	1993	N	950	6.53
4	1993	N	950	5.81
1	1994	SSW	1840	7.51
2	1994	N	950	7.73
3	1994	N	950	8.77
4	1994	SSW	1840	10.20
1	1995	N	950	4.86
2	1995	N	950	6.02
3	1995	S	1570	13.20
4	1995	S	1570	6.01

Average $\chi/Q(1986-1995) = 6.94 \times 10^{-6}$

Table 7.2 Sequoyah Maximum Quarterly D/Q (1986-1995) Sorted by Quarter

QUARTER	YEAR	MAXIMUM	DISTANCE	D/Q(10 ⁻⁸ 1/M ²)
1	1986	NNW	660	0.92
2	1986	N	950	1.33
3	1986	N	950	1.57
4	1986	SSW	1840	1.56
1	1987	SSW	1840	1.34
2	1987	N	950	1.78
3	1987	N	950	1.30
4	1987	SSW	1840	1.01
1	1988	N	950	1.09
2	1988	SSW	1840	1.08
3	1988	N	950	1.29
4	1988	SSW	1840	1.10
1	1989	SSW	1840	1.16
2	1989	N	950	1.63
3	1989	N	950	1.28
4	1989	SSW	1840	0.97
1	1990	N	950	1.22
2	1990	N	950	1.19
3	1990	SSW	1840	1.09
4	1990	SSW	1840	1.10
1	1991	N	950	1.03
2	1991	N	950	1.87
3	1991	N	950	1.33
4	1991	N	950	1.29
1	1992	SSW	1840	1.05
2	1992	N	950	1.12
3	1992	N	950	1.46
4	1992	SSW	1840	1.10
1	1993	SSW	1840	1.31
2	1993	N	950	1.47
3	1993	N	950	1.41
4	1993	N	950	1.25
1	1994	SSW	1840	1.13
2	1994	N	950	1.43
3	1994	N	950	1.80
4	1994	SSW	1840	1.69
1	1995	SSW	1840	0.99
2	1995	N	950	1.78
3	1995	S	1570	1.42
4	1995	S	1570	1.13

Average D/Q(1986-1995) = 1.30 x 10⁻⁸

Table 7.3 DOSE FACTORS FOR SUBMERSION IN NOBLE GASES

	Submersion dose mrem/y per $\mu\text{Ci}/\text{m}^3$		Air dose mrad/y per $\mu\text{Ci}/\text{m}^3$	
	DFB_i	DFS_i	$\text{DF}_{\gamma i}$	$\text{DF}_{\beta i}$
Kr-83m	7.56E-02	---	1.93E+01	2.88E+02
Kr-85m	1.17E+03	1.46E+03	1.23E+03	1.97E+03
Kr-85	1.61E+01	1.34E+03	1.72E+01	1.95E+03
Kr-87	5.92E+03	9.73E+03	6.17E+03	1.03E+04
Kr-88	1.47E+04	2.37E+03	1.52E+04	2.93E+03
Kr-89	1.66E+04	1.01E+04	1.73E+04	1.06E+04
Kr-90	1.56E+04	7.29E+03	1.63E+04	7.83E+03
Xe-131m	9.15E+01	4.76E+02	1.56E+02	1.11E+03
Xe-133m	2.51E+02	9.94E+02	3.27E+02	1.48E+03
Xe-133	2.94E+02	3.06E+02	3.53E+02	1.05E+03
Xe-135m	3.12E+03	7.11E+02	3.36E+03	7.39E+02
Xe-135	1.81E+03	1.86E+03	1.92E+03	2.46E+03
Xe-137	1.42E+03	1.22E+04	1.51E+03	1.27E+04
Xe-138	8.83E+03	4.13E+03	9.21E+03	4.75E+03
Ar-41	8.84E+03	2.69E+03	9.30E+03	3.28E+03

Reference:
Regulatory Guide 1.109, Table B-1.

Table 7.4 SECTOR ELEMENTS CONSIDERED FOR POPULATION DOSES

Range of Sector Element	Midpoint of Sector Element
Unrestricted Area boundary - 1 mile	0.8 mile
1 - 2 miles	1.5 miles
2 - 3 miles	2.5 miles
3 - 4 miles	3.5 miles
4 - 5 miles	4.5 miles
5 - 10 miles	7.5 miles
10 - 20 miles	15 miles
20 - 30 miles	25 miles
30 - 40 miles	35 miles
40 - 50 miles	45 miles

Table 7.5 POPULATION WITHIN EACH SECTOR ELEMENT

	Sector Midpoint (miles)									
	0.8	1.5	2.5	3.5	4.5	7.5	15	25	35	45
N	20	41	213	129	66	1784	5453	3470	2610	11145
NNE	0	30	123	182	62	600	0628	4910	8250	10625
NE	0	0	67	67	94	581	2884	6998	7047	18080
ENE	0	11	24	222	300	773	4707	5747	29477	18679
E	0	70	11	191	137	918	7440	6808	5072	4129
ESE	0	118	113	194	137	1849	46521	5044	1896	3624
SE	0	179	322	168	205	1507	6005	5461	15641	3417
SSE	0	125	370	750	601	2347	13242	8596	34279	1648
S	0	67	143	229	811	3930	28008	26690	19642	11622
SSW	0	82	140	400	170	8927	96966	55597	21349	11978
SW	0	10	306	634	194	9787	94225	23455	11641	11109
WSW	20	190	642	1124	1669	19089	28405	4106	15081	9548
W	10	20	233	657	657	5225	1580	6350	5699	7707
WNW	10	30	365	598	598	2622	6540	4920	6699	2450
NW	50	80	292	569	336	2696	1410	1750	1217	15856
NNW	10	263	80	75	213	1610	471	3130	2835	5719

Table 7.6 INHALATION DOSE FACTORS
(mrem/pCi inhaled)
(Page 1 of 8)
ADULT

	bone	liver	t body	thyroid	kidney	lung	gi-lli
H-3	1.58E-07	1.58E-07	1.58E-07	1.58E-07	1.58E-07	1.58E-07	1.58E-07
C-14	2.27E-06	4.26E-07	4.26E-07	4.26E-07	4.26E-07	4.26E-07	4.26E-07
Na-24	1.28E-06	1.28E-06	1.28E-06	1.28E-06	1.28E-06	1.28E-06	1.28E-06
P-32	1.65E-04	9.64E-06	6.26E-06	0.00E+00	0.00E+00	0.00E+00	1.08E-05
Cr-51	0.00E+00	0.00E+00	1.25E-08	7.44E-09	2.85E-09	1.80E-06	4.15E-07
Mn-54	0.00E+00	4.95E-06	7.87E-07	0.00E+00	1.23E-06	1.75E-04	9.67E-06
Mn-56	0.00E+00	1.55E-10	2.29E-11	0.00E+00	1.63E-10	1.18E-06	2.53E-06
Fe-55	3.07E-06	2.12E-06	4.93E-07	0.00E+00	0.00E+00	9.01E-06	7.54E-07
Fe-59	1.47E-06	3.47E-06	1.32E-06	0.00E+00	0.00E+00	1.27E-04	2.35E-05
Co-57	0.00E+00	8.65E-08	8.39E-08	0.00E+00	0.00E+00	4.62E-05	3.93E-06
Co-58	0.00E+00	1.98E-07	2.59E-07	0.00E+00	0.00E+00	1.16E-04	1.33E-05
Co-60	0.00E+00	1.44E-06	1.85E-06	0.00E+00	0.00E+00	7.46E-04	3.56E-05
Ni-63	5.40E-05	3.93E-06	1.81E-06	0.00E+00	0.00E+00	2.23E-05	1.67E-06
Ni-65	1.92E-10	2.62E-11	1.14E-11	0.00E+00	0.00E+00	7.00E-07	1.54E-06
Cu-64	0.00E+00	1.83E-10	7.69E-11	0.00E+00	5.78E-10	8.48E-07	6.12E-06
Zn-65	4.05E-06	1.29E-05	5.82E-06	0.00E+00	8.62E-06	1.08E-04	6.68E-06
Zn-69	4.23E-12	8.14E-12	5.65E-13	0.00E+00	5.27E-12	1.15E-07	2.04E-09
Zn-69m	1.02E-09	2.45E-09	2.24E-10	0.00E+00	1.48E-09	2.38E-06	1.71E-05
Br-82	0.00E+00	0.00E+00	1.69E-06	0.00E+00	0.00E+00	0.00E+00	1.30E-06
Br-83	0.00E+00	0.00E+00	3.01E-08	0.00E+00	0.00E+00	0.00E+00	2.90E-08
Br-84	0.00E+00	0.00E+00	3.91E-08	0.00E+00	0.00E+00	0.00E+00	2.05E-13
Br-85	0.00E+00	0.00E+00	1.60E-09	0.00E+00	0.00E+00	0.00E+00	0.00E+00
Rb-86	0.00E+00	1.69E-05	7.37E-06	0.00E+00	0.00E+00	0.00E+00	2.08E-06
Rb-88	0.00E+00	4.84E-08	2.41E-08	0.00E+00	0.00E+00	0.00E+00	4.18E-19
Rb-89	0.00E+00	3.20E-08	2.12E-08	0.00E+00	0.00E+00	0.00E+00	1.16E-21
Sr-89	3.80E-05	0.00E+00	1.09E-06	0.00E+00	0.00E+00	1.75E-04	4.37E-05
Sr-90	1.24E-02	0.00E+00	7.62E-04	0.00E+00	0.00E+00	1.20E-03	9.02E-05
Sr-91	7.74E-09	0.00E+00	3.13E-10	0.00E+00	0.00E+00	4.56E-06	2.39E-05
Sr-92	8.43E-10	0.00E+00	3.64E-11	0.00E+00	0.00E+00	2.06E-06	5.38E-06
Y-90	2.61E-07	0.00E+00	7.01E-09	0.00E+00	0.00E+00	2.12E-05	6.32E-05
Y-91m	3.26E-11	0.00E+00	1.27E-12	0.00E+00	0.00E+00	2.40E-07	1.66E-10
Y-91	5.78E-05	0.00E+00	1.55E-06	0.00E+00	0.00E+00	2.13E-04	4.81E-05
Y-92	1.29E-09	0.00E+00	3.77E-11	0.00E+00	0.00E+00	1.96E-06	9.19E-06
Y-93	1.18E-08	0.00E+00	3.26E-10	0.00E+00	0.00E+00	6.06E-06	5.27E-05
Zr-95	1.34E-05	4.30E-06	2.91E-06	0.00E+00	6.77E-06	2.21E-04	1.88E-05
Zr-97	1.21E-08	2.45E-09	1.13E-09	0.00E+00	3.71E-09	9.84E-06	6.54E-05
Nb-95	1.76E-06	9.77E-07	5.26E-07	0.00E+00	9.67E-07	6.31E-05	1.30E-05
Nb-97	2.78E-11	7.03E-12	2.56E-12	0.00E+00	8.18E-12	3.00E-07	3.02E-08
Mo-99	0.00E+00	1.51E-08	2.87E-09	0.00E+00	3.64E-08	1.14E-05	3.10E-05
Tc-99m	1.29E-13	3.64E-13	4.63E-12	0.00E+00	5.52E-12	9.55E-08	5.20E-07
Tc-101	5.22E-15	7.52E-15	7.38E-14	0.00E+00	1.35E-13	4.99E-08	1.36E-21
Ru-103	1.91E-07	0.00E+00	8.23E-08	0.00E+00	7.29E-07	6.31E-05	1.38E-05
Ru-105	9.88E-11	0.00E+00	3.89E-11	0.00E+00	1.27E-10	1.37E-06	6.02E-06
Ru-106	8.64E-06	0.00E+00	1.09E-06	0.00E+00	1.67E-05	1.17E-03	1.14E-04
Ag-110m	1.35E-06	1.25E-06	7.43E-07	0.00E+00	2.46E-06	5.79E-04	3.78E-05

Table 7.6 INHALATION DOSE FACTORS
(mrem/pCi inhaled)
(Page 2 of 8)
ADULT

	bone	liver	t body	thyroid	kidney	lung	gi-lli
Sb-124	3.90E-06	7.36E-08	1.55E-06	9.44E-09	0.00E+00	3.10E-04	5.08E-05
Sb-125	6.67E-06	7.44E-08	1.58E-06	6.75E-09	0.00E+00	2.18E-04	1.26E-05
Sn-125	1.16E-06	3.12E-08	7.03E-08	2.59E-08	0.00E+00	7.37E-05	6.81E-05
Te-125m	4.27E-07	1.98E-07	5.84E-08	1.31E-07	1.55E-06	3.92E-05	8.83E-06
Te-127m	1.58E-06	7.21E-07	1.96E-07	4.11E-07	5.72E-06	1.20E-04	1.87E-05
Te-127	1.75E-10	8.03E-11	3.87E-11	1.32E-10	6.37E-10	8.14E-07	7.17E-06
Te-129m	1.22E-06	5.84E-07	1.98E-07	4.30E-07	4.57E-06	1.45E-04	4.79E-05
Te-129	6.22E-12	2.99E-12	1.55E-12	4.87E-12	2.34E-11	2.42E-07	1.96E-08
Te-131m	8.74E-09	5.45E-09	3.63E-09	6.88E-09	3.86E-08	1.82E-05	6.95E-05
Te-131	1.39E-12	7.44E-13	4.49E-13	1.17E-12	5.46E-12	1.74E-07	2.30E-09
Te-132	3.25E-08	2.69E-08	2.02E-08	2.37E-08	1.82E-07	3.60E-05	6.37E-05
I-130	5.72E-07	1.68E-06	6.60E-07	1.42E-04	2.61E-06	0.00E+00	9.61E-07
I-131	3.15E-06	4.47E-06	2.56E-06	1.49E-03	7.66E-06	0.00E+00	7.85E-07
I-132	1.45E-07	4.07E-07	1.45E-07	1.43E-05	6.48E-07	0.00E+00	5.08E-08
I-133	1.08E-06	1.85E-06	5.65E-07	2.69E-04	3.23E-06	0.00E+00	1.11E-06
I-134	8.05E-08	2.16E-07	7.69E-08	3.73E-06	3.44E-07	0.00E+00	1.26E-10
I-135	3.35E-07	8.73E-07	3.21E-07	5.60E-05	1.39E-06	0.00E+00	6.56E-07
Cs-134	4.66E-05	1.06E-04	9.10E-05	0.00E+00	3.59E-05	1.22E-05	1.30E-06
Cs-136	4.88E-06	1.83E-05	1.38E-05	0.00E+00	1.07E-05	1.50E-06	1.46E-06
Cs-137	5.98E-05	7.76E-05	5.35E-05	0.00E+00	2.78E-05	9.40E-06	1.05E-06
Cs-138	4.14E-08	7.76E-08	4.05E-08	0.00E+00	6.00E-08	6.07E-09	2.33E-13
Ba-139	1.17E-10	8.32E-14	3.42E-12	0.00E+00	7.78E-14	4.70E-07	1.12E-07
Ba-140	4.88E-06	6.13E-09	3.21E-07	0.00E+00	2.09E-09	1.59E-04	2.73E-05
Ba-141	1.25E-11	9.41E-15	4.20E-13	0.00E+00	8.75E-15	2.42E-07	1.45E-17
Ba-142	3.29E-12	3.38E-15	2.07E-13	0.00E+00	2.86E-15	1.49E-07	1.96E-26
La-140	4.30E-08	2.17E-08	5.73E-09	0.00E+00	0.00E+00	1.70E-05	5.73E-05
La-142	8.54E-11	3.88E-11	9.65E-12	0.00E+00	0.00E+00	7.91E-07	2.64E-07
Ce-141	2.49E-06	1.69E-06	1.91E-07	0.00E+00	7.83E-07	4.52E-05	1.50E-05
Ce-143	2.33E-08	1.72E-08	1.91E-09	0.00E+00	7.60E-09	9.97E-06	2.83E-05
Ce-144	4.29E-04	1.79E-04	2.30E-05	0.00E+00	1.06E-04	9.72E-04	1.02E-04
Pr-143	1.17E-06	4.69E-07	5.80E-08	0.00E+00	2.70E-07	3.51E-05	2.50E-05
Pr-144	3.76E-12	1.56E-12	1.91E-13	0.00E+00	8.81E-13	1.27E-07	2.69E-18
Nd-147	6.59E-07	7.62E-07	4.56E-08	0.00E+00	4.45E-07	2.76E-05	2.16E-05
W-187	1.06E-09	8.85E-10	3.10E-10	0.00E+00	0.00E+00	3.63E-06	1.94E-05
Np-239	2.87E-08	2.82E-09	1.55E-09	0.00E+00	8.75E-09	4.70E-06	1.49E-05

NOTE: The tritium dose factor for bone is assumed to be equal to the total body dose factor.

Reference:

Regulatory Guide 1.109, Table E-7.

Dose Factors for Co-57, Zn-69m, Br-82, Nb-97, Sn-125, Sb-124 and Sb-125 are from NUREG-0172 Age Specific Radiation Dose Commitment Factors for a One Year Chronic Intake, November 1977, Table 8.

Table 7.6 INHALATION DOSE FACTORS
(mrem/pCi inhaled)
(Page 3 of 8)
TEEN

	bone	liver	t body	thyroid	kidney	lung	gi-lli
H-3	1.59E-07	1.59E-07	1.59E-07	1.59E-07	1.59E-07	1.59E-07	1.59E-07
C-14	3.25E-06	6.09E-07	6.09E-07	6.09E-07	6.09E-07	6.09E-07	6.09E-07
Na-24	1.72E-06	1.72E-06	1.72E-06	1.72E-06	1.72E-06	1.72E-06	1.72E-06
P-32	2.36E-04	1.37E-05	8.95E-06	0.00E+00	0.00E+00	0.00E+00	1.16E-05
Cr-51	0.00E+00	0.00E+00	1.69E-08	9.37E-09	3.84E-09	2.62E-06	3.75E-07
Mn-54	0.00E+00	6.39E-06	1.05E-06	0.00E+00	1.59E-06	2.48E-04	8.35E-06
Mn-56	0.00E+00	2.12E-10	3.15E-11	0.00E+00	2.24E-10	1.90E-06	7.18E-06
Fe-55	4.18E-06	2.98E-06	6.93E-07	0.00E+00	0.00E+00	1.55E-05	7.99E-07
Fe-59	1.99E-06	4.62E-06	1.79E-06	0.00E+00	0.00E+00	1.91E-04	2.23E-05
Co-57	0.00E+00	1.18E-07	1.15E-07	0.00E+00	0.00E+00	7.33E-05	3.93E-06
Co-58	0.00E+00	2.59E-07	3.47E-07	0.00E+00	0.00E+00	1.68E-04	1.19E-05
Co-60	0.00E+00	1.89E-06	2.48E-06	0.00E+00	0.00E+00	1.09E-03	3.24E-05
Ni-63	7.25E-05	5.43E-06	2.47E-06	0.00E+00	0.00E+00	3.84E-05	1.77E-06
Ni-65	2.73E-10	3.66E-11	1.59E-11	0.00E+00	0.00E+00	1.17E-06	4.59E-06
Cu-64	0.00E+00	2.54E-10	1.06E-10	0.00E+00	8.01E-10	1.39E-06	7.68E-06
Zn-65	4.82E-06	1.67E-05	7.80E-06	0.00E+00	1.08E-05	1.55E-04	5.83E-06
Zn-69	6.04E-12	1.15E-11	8.07E-13	0.00E+00	7.53E-12	1.98E-07	3.56E-08
Zn-69m	1.44E-09	3.39E-09	3.11E-10	0.00E+00	2.06E-09	3.92E-06	2.14E-05
Br-82	0.00E+00	0.00E+00	2.28E-06	0.00E+00	0.00E+00	0.00E+00	0.00E+00
Br-83	0.00E+00	0.00E+00	4.30E-08	0.00E+00	0.00E+00	0.00E+00	0.00E+00
Br-84	0.00E+00	0.00E+00	5.41E-08	0.00E+00	0.00E+00	0.00E+00	0.00E+00
Br-85	0.00E+00	0.00E+00	2.29E-09	0.00E+00	0.00E+00	0.00E+00	0.00E+00
Rb-86	0.00E+00	2.38E-05	1.05E-05	0.00E+00	0.00E+00	0.00E+00	2.21E-06
Rb-88	0.00E+00	6.82E-08	3.40E-08	0.00E+00	0.00E+00	0.00E+00	3.65E-15
Rb-89	0.00E+00	4.40E-08	2.91E-08	0.00E+00	0.00E+00	0.00E+00	4.22E-17
Sr-89	5.43E-05	0.00E+00	1.56E-06	0.00E+00	0.00E+00	3.02E-04	4.64E-05
Sr-90	1.35E-02	0.00E+00	8.35E-04	0.00E+00	0.00E+00	2.06E-03	9.56E-05
Sr-91	1.10E-08	0.00E+00	4.39E-10	0.00E+00	0.00E+00	7.59E-06	3.24E-05
Sr-92	1.19E-09	0.00E+00	5.08E-11	0.00E+00	0.00E+00	3.43E-06	1.49E-05
Y-90	3.73E-07	0.00E+00	1.00E-08	0.00E+00	0.00E+00	3.66E-05	6.99E-05
Y-91m	4.63E-11	0.00E+00	1.77E-12	0.00E+00	0.00E+00	4.00E-07	3.77E-09
Y-91	8.26E-05	0.00E+00	2.21E-06	0.00E+00	0.00E+00	3.67E-04	5.11E-05
Y-92	1.84E-09	0.00E+00	5.36E-11	0.00E+00	0.00E+00	3.35E-06	2.06E-05
Y-93	1.69E-08	0.00E+00	4.65E-10	0.00E+00	0.00E+00	1.04E-05	7.24E-05
Zr-95	1.82E-05	5.73E-06	3.94E-06	0.00E+00	8.42E-06	3.36E-04	1.86E-05
Zr-97	1.72E-08	3.40E-09	1.57E-09	0.00E+00	5.15E-09	1.62E-05	7.88E-05
Nb-95	2.32E-06	1.29E-06	7.08E-07	0.00E+00	1.25E-06	9.39E-05	1.21E-05
Nb-97	3.92E-11	9.72E-12	3.55E-12	0.00E+00	1.14E-11	4.91E-07	2.71E-07
Mo-99	0.00E+00	2.11E-08	4.03E-09	0.00E+00	5.14E-08	1.92E-05	3.36E-05
Tc-99m	1.73E-13	4.83E-13	6.24E-12	0.00E+00	7.20E-12	1.44E-07	7.66E-07
Tc-101	7.40E-15	1.05E-14	1.03E-13	0.00E+00	1.90E-13	8.34E-08	1.09E-16
Ru-103	2.63E-07	0.00E+00	7.70E-07	0.00E+00	9.29E-07	9.79E-05	1.36E-05
Ru-105	1.40E-10	0.00E+00	5.42E-11	0.00E+00	1.76E-10	2.27E-06	1.13E-05
Ru-106	1.23E-05	0.00E+00	1.55E-06	0.00E+00	2.38E-05	2.01E-03	1.20E-04
Ag-110m	1.73E-06	1.64E-06	9.99E-07	0.00E+00	3.13E-06	8.44E-04	3.41E-05

Table 7.6 INHALATION DOSE FACTORS
(mrem/pCi inhaled)
(Page 4 of 8)

	TEEN						
	bone	liver	t body	thyroid	kidney	lung	gi-lli
Sb-124	5.38E-06	9.92E-08	2.10E-06	1.22E-08	0.00E+00	4.81E-04	4.98E-05
Sb-125	9.23E-06	1.01E-07	2.15E-06	8.80E-09	0.00E+00	3.42E-04	1.24E-05
Sn-125	1.66E-06	4.42E-08	9.99E-08	3.45E-08	0.00E+00	1.26E-04	7.29E-05
Te-125m	6.10E-07	2.80E-07	8.34E-08	1.75E-07	0.00E+00	6.70E-05	9.38E-06
Te-127m	2.25E-06	1.02E-06	2.73E-07	5.48E-07	8.17E-06	2.07E-04	1.99E-05
Te-127	2.51E-10	1.14E-10	5.52E-11	1.77E-10	9.10E-10	1.40E-06	1.01E-05
Te-129m	1.74E-06	8.23E-07	2.81E-07	5.72E-07	6.49E-06	2.47E-04	5.06E-05
Te-129	8.87E-12	4.22E-12	2.20E-12	6.48E-12	3.32E-11	4.12E-07	2.02E-07
Te-131m	1.23E-08	7.51E-09	5.03E-09	9.06E-09	5.49E-08	2.97E-05	7.76E-05
Te-131	1.97E-12	1.04E-12	6.30E-13	1.55E-12	7.72E-12	2.92E-07	1.89E-09
Te-132	4.50E-08	3.63E-08	2.74E-08	3.07E-08	2.44E-07	5.61E-05	5.79E-05
I-130	7.80E-07	2.24E-06	8.96E-07	1.86E-04	3.44E-06	0.00E+00	1.14E-06
I-131	4.43E-06	6.14E-06	3.30E-06	1.83E-03	1.05E-05	0.00E+00	8.11E-07
I-132	1.99E-07	5.47E-07	1.97E-07	1.89E-05	8.65E-07	0.00E+00	1.59E-07
I-133	1.52E-06	2.56E-06	7.78E-07	3.65E-04	4.49E-06	0.00E+00	1.29E-06
I-134	1.11E-07	2.90E-07	1.05E-07	4.94E-06	4.58E-07	0.00E+00	2.55E-09
I-135	4.62E-07	1.18E-06	4.36E-07	7.76E-05	1.86E-06	0.00E+00	8.69E-07
Cs-134	6.28E-05	1.41E-04	6.86E-05	0.00E+00	4.69E-05	1.83E-05	1.22E-06
Cs-136	6.44E-06	2.42E-05	1.71E-05	0.00E+00	1.38E-05	2.22E-06	1.36E-06
Cs-137	8.38E-05	1.06E-04	3.89E-05	0.00E+00	3.80E-05	1.51E-05	1.06E-06
Cs-138	5.82E-08	1.07E-07	5.58E-08	0.00E+00	8.28E-08	9.84E-09	3.38E-11
Ba-139	1.67E-10	1.18E-13	4.87E-12	0.00E+00	1.11E-13	8.08E-07	8.06E-07
Ba-140	6.84E-06	8.38E-09	4.40E-07	0.00E+00	2.85E-09	2.54E-04	2.86E-05
Ba-141	1.78E-11	1.32E-14	5.93E-13	0.00E+00	1.23E-14	4.11E-07	9.33E-14
Ba-142	4.62E-12	4.63E-15	2.84E-13	0.00E+00	3.92E-15	2.39E-07	5.99E-20
La-140	5.99E-08	2.95E-08	7.82E-09	0.00E+00	0.00E+00	2.68E-05	6.09E-05
La-142	1.20E-10	5.31E-11	1.32E-11	0.00E+00	0.00E+00	1.27E-06	1.50E-06
Ce-141	3.55E-06	2.37E-06	2.71E-07	0.00E+00	1.11E-06	7.67E-05	1.58E-05
Ce-143	3.32E-08	2.42E-08	2.70E-09	0.00E+00	1.08E-08	1.63E-05	3.19E-05
Ce-144	6.11E-04	2.53E-04	3.28E-05	0.00E+00	1.51E-04	1.67E-03	1.08E-04
Pr-143	1.67E-06	6.64E-07	8.28E-08	0.00E+00	3.86E-07	6.04E-05	2.67E-05
Pr-144	5.37E-12	2.20E-12	2.72E-13	0.00E+00	1.26E-12	2.19E-07	2.94E-14
Nd-147	9.83E-07	1.07E-06	6.41E-08	0.00E+00	6.28E-07	4.65E-05	2.28E-05
W-187	1.50E-09	1.22E-09	4.29E-10	0.00E+00	0.00E+00	5.92E-06	2.21E-05
Np-239	4.23E-08	3.99E-09	2.21E-09	0.00E+00	1.25E-08	8.11E-06	1.65E-05

NOTE: The tritium dose factor for bone is assumed to be equal to the total body dose factor.

Reference:

Regulatory Guide 1.109, Table E-8.

Dose Factors for Co-57, Zn-69m, Br-82, Nb-97, Sn-125, Sb-124 and Sb-125 are from NUREG-0172 Age Specific Radiation Dose Commitment Factors for a One Year Chronic Intake, November 1977, Table 8.

Table 7.6 INHALATION DOSE FACTORS
(mrem/pCi inhaled)
(Page 5 of 8)
CHILD

	bone	liver	t body	thyroid	kidney	lung	gi-lli
H-3	3.04E-07	3.04E-07	3.04E-07	3.04E-07	3.04E-07	3.04E-07	3.04E-07
C-14	9.70E-06	1.82E-06	1.82E-06	1.82E-06	1.82E-06	1.82E-06	1.82E-06
Na-24	4.35E-06	4.35E-06	4.35E-06	4.35E-06	4.35E-06	4.35E-06	4.35E-06
P-32	7.04E-04	3.09E-05	2.67E-05	0.00E+00	0.00E+00	0.00E+00	1.14E-05
Cr-51	0.00E+00	0.00E+00	4.17E-08	2.31E-08	6.57E-09	4.59E-06	2.93E-07
Mn-54	0.00E+00	1.16E-05	2.57E-06	0.00E+00	2.71E-06	4.26E-04	6.19E-06
Mn-56	0.00E+00	4.48E-10	8.43E-11	0.00E+00	4.52E-10	3.55E-06	3.33E-05
Fe-55	1.28E-05	6.80E-06	2.10E-06	0.00E+00	0.00E+00	3.00E-05	7.75E-07
Fe-59	5.59E-06	9.04E-06	4.51E-06	0.00E+00	0.00E+00	3.43E-04	1.91E-05
Co-57	0.00E+00	2.44E-07	2.88E-07	0.00E+00	0.00E+00	1.37E-04	3.58E-06
Co-58	0.00E+00	4.79E-07	8.55E-07	0.00E+00	0.00E+00	2.99E-04	9.29E-06
Co-60	0.00E+00	3.55E-06	6.12E-06	0.00E+00	0.00E+00	1.91E-03	2.60E-05
Ni-63	2.22E-04	1.25E-05	7.56E-06	0.00E+00	0.00E+00	7.43E-05	1.71E-06
Ni-65	8.08E-10	7.99E-11	4.44E-11	0.00E+00	0.00E+00	2.21E-06	2.27E-05
Cu-64	0.00E+00	5.39E-10	2.90E-10	0.00E+00	1.63E-09	2.59E-06	9.92E-06
Zn-65	1.15E-05	3.06E-05	1.90E-05	0.00E+00	1.93E-05	2.69E-04	4.41E-06
Zn-69	1.81E-11	2.61E-11	2.41E-12	0.00E+00	1.58E-11	3.84E-07	2.75E-06
Zn-69m	4.26E-09	7.28E-09	8.59E-10	0.00E+00	4.22E-09	7.36E-06	2.71E-05
Br-82	0.00E+00	0.00E+00	5.66E-06	0.00E+00	0.00E+00	0.00E+00	0.00E+00
Br-83	0.00E+00	0.00E+00	1.28E-07	0.00E+00	0.00E+00	0.00E+00	0.00E+00
Br-84	0.00E+00	0.00E+00	1.48E-07	0.00E+00	0.00E+00	0.00E+00	0.00E+00
Br-85	0.00E+00	0.00E+00	6.84E-09	0.00E+00	0.00E+00	0.00E+00	0.00E+00
Rb-86	0.00E+00	5.36E-05	3.09E-05	0.00E+00	0.00E+00	0.00E+00	2.16E-06
Rb-88	0.00E+00	1.52E-07	9.90E-08	0.00E+00	0.00E+00	0.00E+00	4.66E-09
Rb-89	0.00E+00	9.33E-08	7.83E-08	0.00E+00	0.00E+00	0.00E+00	5.11E-10
Sr-89	1.62E-04	0.00E+00	4.66E-06	0.00E+00	0.00E+00	5.83E-04	4.52E-05
Sr-90	2.73E-02	0.00E+00	1.74E-03	0.00E+00	0.00E+00	3.99E-03	9.28E-05
Sr-91	3.28E-08	0.00E+00	1.24E-09	0.00E+00	0.00E+00	1.44E-05	4.70E-05
Sr-92	3.54E-09	0.00E+00	1.42E-10	0.00E+00	0.00E+00	6.49E-06	6.55E-05
Y-90	1.11E-06	0.00E+00	2.99E-08	0.00E+00	0.00E+00	7.07E-05	7.24E-05
Y-91m	1.37E-10	0.00E+00	4.98E-12	0.00E+00	0.00E+00	7.60E-07	4.64E-07
Y-91	2.47E-04	0.00E+00	6.59E-06	0.00E+00	0.00E+00	7.10E-04	4.97E-05
Y-92	5.50E-09	0.00E+00	1.57E-10	0.00E+00	0.00E+00	6.46E-06	6.46E-05
Y-93	5.04E-08	0.00E+00	1.38E-09	0.00E+00	0.00E+00	2.01E-05	1.05E-04
Zr-95	5.13E-05	1.13E-05	1.00E-05	0.00E+00	1.61E-05	6.03E-04	1.65E-05
Zr-97	5.07E-08	7.34E-09	4.32E-09	0.00E+00	1.05E-08	3.06E-05	9.49E-05
Nb-95	6.35E-06	2.48E-06	1.77E-06	0.00E+00	2.33E-06	1.66E-04	1.00E-05
Nb-97	1.16E-10	2.08E-11	9.74E-12	0.00E+00	2.31E-11	9.23E-07	7.52E-06
Mo-99	0.00E+00	4.66E-08	1.15E-08	0.00E+00	1.06E-07	3.66E-05	3.42E-05
Tc-99m	4.81E-13	9.41E-13	1.56E-11	0.00E+00	1.37E-11	2.57E-07	1.30E-06
Tc-101	2.19E-14	2.30E-14	2.91E-13	0.00E+00	3.92E-13	1.58E-07	4.41E-09
Ru-103	7.55E-07	0.00E+00	2.90E-07	0.00E+00	1.90E-06	1.79E-04	1.21E-05
Ru-105	4.13E-10	0.00E+00	1.50E-10	0.00E+00	3.63E-10	4.30E-06	2.69E-05
Ru-106	3.68E-05	0.00E+00	4.57E-06	0.00E+00	4.97E-05	3.87E-03	1.16E-04
Ag-110m	4.56E-06	3.08E-06	2.47E-06	0.00E+00	5.74E-06	1.48E-03	2.71E-05

Table 7.6 INHALATION DOSE FACTORS
(mrem/pCi inhaled)
(Page 6 of 8)
CHILD

	bone	liver	t body	thyroid	kidney	lung	gi-lli
Sb-124	1.55E-05	2.00E-07	5.41E-06	3.41E-08	0.00E+00	8.76E-04	4.43E-05
Sb-125	2.66E-05	2.05E-07	5.59E-06	2.46E-08	0.00E+00	6.27E-04	1.09E-05
Sn-125	4.95E-06	9.94E-08	2.95E-07	1.03E-07	0.00E+00	2.43E-04	7.17E-05
Te-125m	1.82E-06	6.29E-07	2.47E-07	5.20E-07	0.00E+00	1.29E-04	9.13E-06
Te-127m	6.72E-06	2.31E-06	8.16E-07	1.64E-06	1.72E-05	4.00E-04	1.93E-05
Te-127	7.49E-10	2.57E-10	1.65E-10	5.30E-10	1.91E-09	2.71E-06	1.52E-05
Te-129m	5.19E-06	1.85E-06	8.22E-07	1.71E-06	1.36E-05	4.76E-04	4.91E-05
Te-129	2.64E-11	9.45E-12	6.44E-12	1.93E-11	6.94E-11	7.93E-07	6.89E-06
Te-131m	3.63E-08	1.60E-08	1.37E-08	2.64E-08	1.08E-07	5.56E-05	8.32E-05
Te-131	5.87E-12	2.28E-12	1.78E-12	4.59E-12	1.59E-11	5.55E-07	3.60E-07
Te-132	1.30E-07	7.36E-08	7.12E-08	8.58E-08	4.79E-07	1.02E-04	3.72E-05
I-130	2.21E-06	4.43E-06	2.28E-06	4.99E-04	6.61E-06	0.00E+00	1.38E-06
I-131	1.30E-05	1.30E-05	7.37E-06	4.39E-03	2.13E-05	0.00E+00	7.68E-07
I-132	5.72E-07	1.10E-06	5.07E-07	5.23E-05	1.69E-06	0.00E+00	8.65E-07
I-133	4.48E-06	5.49E-06	2.08E-06	1.04E-03	9.13E-06	0.00E+00	1.48E-06
I-134	3.17E-07	5.84E-07	2.69E-07	1.37E-05	8.92E-07	0.00E+00	2.58E-07
I-135	1.33E-06	2.36E-06	1.12E-06	2.14E-04	3.62E-06	0.00E+00	1.20E-06
Cs-134	1.76E-04	2.74E-04	6.07E-05	0.00E+00	8.93E-05	3.27E-05	1.04E-06
Cs-136	1.76E-05	4.62E-05	3.14E-05	0.00E+00	2.58E-05	3.93E-06	1.13E-06
Cs-137	2.45E-04	2.23E-04	3.47E-05	0.00E+00	7.63E-05	2.81E-05	9.78E-07
Cs-138	1.71E-07	2.27E-07	1.50E-07	0.00E+00	1.68E-07	1.84E-08	7.29E-08
Ba-139	4.98E-10	2.66E-13	1.45E-11	0.00E+00	2.33E-13	1.56E-06	1.56E-05
Ba-140	2.00E-05	1.75E-08	1.17E-06	0.00E+00	5.71E-09	4.71E-04	2.75E-05
Ba-141	5.29E-11	2.95E-14	1.72E-12	0.00E+00	2.56E-14	7.89E-07	7.44E-08
Ba-142	1.35E-11	9.73E-15	7.54E-13	0.00E+00	7.87E-15	4.44E-07	7.41E-10
La-140	1.74E-07	6.08E-08	2.04E-08	0.00E+00	0.00E+00	4.94E-05	6.10E-05
La-142	3.50E-10	1.11E-10	3.49E-11	0.00E+00	0.00E+00	2.35E-06	2.05E-05
Ce-141	1.06E-05	5.28E-06	7.83E-07	0.00E+00	2.31E-06	1.47E-04	1.53E-05
Ce-143	9.89E-08	5.37E-08	7.77E-09	0.00E+00	2.26E-08	3.12E-05	3.44E-05
Ce-144	1.83E-03	5.72E-04	9.77E-05	0.00E+00	3.17E-04	3.23E-03	1.05E-04
Pr-143	4.99E-06	1.50E-06	2.47E-07	0.00E+00	8.11E-07	1.17E-04	2.63E-05
Pr-144	1.61E-11	4.99E-12	8.10E-13	0.00E+00	2.64E-12	4.23E-07	5.32E-08
Nd-147	2.92E-06	2.36E-06	1.84E-07	0.00E+00	1.30E-06	8.87E-05	2.22E-05
W-187	4.41E-09	2.61E-09	1.17E-09	0.00E+00	0.00E+00	1.11E-05	2.46E-05
Np-239	1.26E-07	9.04E-09	6.35E-09	0.00E+00	2.63E-08	1.57E-05	1.73E-05

NOTE: The tritium dose factor for bone is assumed to be equal to the total body dose factor.

Reference:

Regulatory Guide 1.109, Table E-9.

Dose Factors for Co-57, Zn-69m, Br-82, Nb-97, Sn-125, Sb-124 and Sb-125 are from NUREG-0172 Age Specific Radiation Dose Commitment Factors for a One Year Chronic Intake, November 1977, Table 8.

Table 7.6 INHALATION DOSE FACTORS
(mrem/pCi inhaled)
(Page 7 of 8)

	INFANT						
	bone	liver	t body	thyroid	kidney	lung	gi-lli
H-3	4.62E-07	4.62E-07	4.62E-07	4.62E-07	4.62E-07	4.62E-07	4.62E-07
C-14	1.89E-05	3.79E-06	3.79E-06	3.79E-06	3.79E-06	3.79E-06	3.79E-06
Na-24	7.54E-06	7.54E-06	7.54E-06	7.54E-06	7.54E-06	7.54E-06	7.54E-06
P-32	1.45E-03	8.03E+05	5.53E-05	0.00E+00	0.00E+00	0.00E+00	1.15E-05
Cr-51	0.00E+00	0.00E+00	6.39E-08	4.11E-08	9.45E-09	9.17E-06	2.55E-07
Mn-54	0.00E+00	1.81E-05	3.56E-06	0.00E+00	3.56E-06	7.14E-04	5.04E-06
Mn-56	0.00E+00	1.10E-09	1.58E-10	0.00E+00	7.86E-10	8.95E-06	5.12E-05
Fe-55	1.41E-05	8.39E-06	2.38E-06	0.00E+00	0.00E+00	6.21E-05	7.82E-07
Fe-59	9.69E-06	1.68E-05	6.77E-06	0.00E+00	0.00E+00	7.25E-04	1.77E-05
Co-57	0.00E+00	4.65E-07	4.58E-07	0.00E+00	0.00E+00	2.71E-04	3.47E-06
Co-58	0.00E+00	8.71E-07	1.30E-06	0.00E+00	0.00E+00	5.55E-04	7.95E-06
Co-60	0.00E+00	5.73E-06	8.41E-06	0.00E+00	0.00E+00	3.22E-03	2.28E-05
Ni-63	2.42E-04	1.46E-05	8.29E-06	0.00E+00	0.00E+00	1.49E-04	1.73E-06
Ni-65	1.71E-09	2.03E-10	8.79E-11	0.00E+00	0.00E+00	5.80E-06	3.58E-05
Cu-64	0.00E+00	1.34E-09	5.53E-10	0.00E+00	2.84E-09	6.64E-06	1.07E-05
Zn-65	1.38E-05	4.47E-05	2.22E-05	0.00E+00	2.32E-05	4.62E-04	3.67E-05
Zn-69	3.85E-11	6.91E-11	5.13E-12	0.00E+00	2.87E-11	1.05E-06	9.44E-06
Zn-69m	8.98E-09	1.84E-08	1.67E-09	0.00E+00	7.45E-09	1.91E-05	2.92E-05
Br-82	0.00E+00	0.00E+00	9.49E-06	0.00E+00	0.00E+00	0.00E+00	0.00E+00
Br-83	0.00E+00	0.00E+00	2.72E-07	0.00E+00	0.00E+00	0.00E+00	0.00E+00
Br-84	0.00E+00	0.00E+00	2.86E-07	0.00E+00	0.00E+00	0.00E+00	0.00E+00
Br-85	0.00E+00	0.00E+00	1.46E-08	0.00E+00	0.00E+00	0.00E+00	0.00E+00
Rb-86	0.00E+00	1.36E-04	6.30E-05	0.00E+00	0.00E+00	0.00E+00	2.17E-06
Rb-88	0.00E+00	3.98E-07	2.05E-07	0.00E+00	0.00E+00	0.00E+00	2.42E-07
Rb-89	0.00E+00	2.29E-07	1.47E-07	0.00E+00	0.00E+00	0.00E+00	4.87E-08
Sr-89	2.84E-04	0.00E+00	8.15E-06	0.00E+00	0.00E+00	1.45E-03	4.57E-05
Sr-90	2.92E-02	0.00E+00	1.85E-03	0.00E+00	0.00E+00	8.03E-03	9.36E-05
Sr-91	6.83E-08	0.00E+00	2.47E-09	0.00E+00	0.00E+00	3.76E-05	5.24E-05
Sr-92	7.50E-09	0.00E+00	2.79E-10	0.00E+00	0.00E+00	1.70E-05	1.00E-04
Y-90	2.35E-06	0.00E+00	6.30E-08	0.00E+00	0.00E+00	1.92E-04	7.43E-05
Y-91m	2.91E-10	0.00E+00	9.90E-12	0.00E+00	0.00E+00	1.99E-06	1.68E-06
Y-91	4.20E-04	0.00E+00	1.12E-05	0.00E+00	0.00E+00	1.75E-03	5.02E-05
Y-92	1.17E-08	0.00E+00	3.29E-10	0.00E+00	0.00E+00	1.75E-05	9.04E-05
Y-93	1.07E-07	0.00E+00	2.91E-09	0.00E+00	0.00E+00	5.46E-05	1.19E-04
Zr-95	8.24E-05	1.99E-05	1.45E-05	0.00E+00	2.22E-05	1.25E-03	1.55E-05
Zr-97	1.07E-07	1.83E-08	8.36E-09	0.00E+00	1.85E-08	7.88E-05	1.00E-04
Nb-95	1.12E-05	4.59E-06	2.70E-06	0.00E+00	3.37E-06	3.42E-04	9.05E-06
Nb-97	2.44E-10	5.21E-11	1.88E-11	0.00E+00	4.07E-11	2.37E-06	1.92E-05
Mo-99	0.00E+00	1.18E-07	2.31E-08	0.00E+00	1.89E-07	9.63E-05	3.48E-05
Tc-99m	9.98E-13	2.06E-12	2.66E-11	0.00E+00	2.22E-11	5.79E-07	1.45E-06
Tc-101	4.65E-14	5.88E-14	5.80E-13	0.00E+00	6.99E-13	4.17E-07	6.03E-07
Ru-103	1.44E-06	0.00E+00	4.85E-07	0.00E+00	3.03E-06	3.94E-04	1.15E-05
Ru-105	8.74E-10	0.00E+00	2.93E-10	0.00E+00	6.42E-10	1.12E-05	3.46E-05
Ru-106	6.20E-05	0.00E+00	7.77E-06	0.00E+00	7.61E-05	8.26E-03	1.17E-04
Ag-110m	7.13E-06	5.16E-06	3.57E-06	0.00E+00	7.80E-06	2.62E-03	2.36E-05

Table 7.6 INHALATION DOSE FACTORS
(mrem/pCi inhaled)
(Page 8 of 8)
INFANT

	bone	liver	t body	thyroid	kidney	lung	gi-lli
Sb-124	2.71E-05	3.97E-07	8.56E-06	7.18E-08	0.00E+00	1.89E-03	4.22E-05
Sb-125	3.69E-05	3.41E-07	7.78E-06	4.45E-08	0.00E+00	1.17E-03	1.05E-05
Sn-125	1.01E-05	2.51E-07	6.00E-07	2.47E-07	0.00E+00	6.43E-04	7.26E-05
Te-125m	3.40E-06	1.42E-06	4.70E-07	1.16E-06	0.00E+00	3.19E-04	9.22E-06
Te-127m	1.19E-05	4.93E-06	1.48E-06	3.48E-06	2.68E-05	9.37E-04	1.95E-05
Te-127	1.59E-09	6.81E-10	3.49E-10	1.32E-09	3.47E-09	7.39E-06	1.74E-05
Te-129m	1.01E-05	4.35E-06	1.59E-06	3.91E-06	2.27E-05	1.20E-03	4.93E-05
Te-129	5.63E-11	2.48E-11	1.34E-11	4.82E-11	1.25E-10	2.14E-06	1.88E-05
Te-131m	7.62E-08	3.93E-08	2.59E-08	6.38E-08	1.89E-07	1.42E-04	8.51E-05
Te-131	1.24E-11	5.87E-12	3.57E-12	1.13E-11	2.85E-11	1.47E-06	5.87E-06
Te-132	2.66E-07	1.69E-07	1.26E-07	1.99E-07	7.39E-07	2.43E-04	3.15E-05
I-130	4.54E-06	9.91E-06	3.98E-06	1.14E-03	1.09E-05	0.00E+00	1.42E-06
I-131	2.71E-05	3.17E-05	1.40E-05	1.06E-02	3.70E-05	0.00E+00	7.56E-07
I-132	1.21E-06	2.53E-06	8.99E-07	1.21E-04	2.82E-06	0.00E+00	1.36E-06
I-133	9.46E-06	1.37E-05	4.00E-06	2.54E-03	1.60E-05	0.00E+00	1.54E-06
I-134	6.58E-07	1.34E-06	4.75E-07	3.18E-05	1.49E-06	0.00E+00	9.21E-07
I-135	2.76E-06	5.43E-06	1.98E-06	4.97E-04	6.05E-06	0.00E+00	1.31E-06
Cs-134	2.83E-04	5.02E-04	5.32E-05	0.00E+00	1.36E-04	5.69E-05	9.53E-07
Cs-136	3.45E-05	9.61E-05	3.78E-05	0.00E+00	4.03E-05	8.40E-06	1.02E-06
Cs-137	3.92E-04	4.37E-04	3.25E-05	0.00E+00	1.23E-04	5.09E-05	9.53E-07
Cs-138	3.61E-07	5.58E-07	2.84E-07	0.00E+00	2.93E-07	4.67E-08	6.26E-07
Ba-139	1.06E-09	7.03E-13	3.07E-11	0.00E+00	4.23E-13	4.25E-06	3.64E-05
Ba-140	4.00E-05	4.00E-08	2.07E-06	0.00E+00	9.59E-09	1.14E-03	2.74E-05
Ba-141	1.12E-10	7.70E-14	3.55E-12	0.00E+00	4.64E-14	2.12E-06	3.39E-06
Ba-142	2.84E-11	2.36E-14	1.40E-12	0.00E+00	1.36E-14	1.11E-06	4.95E-07
La-140	3.61E-07	1.43E-07	3.68E-08	0.00E+00	0.00E+00	1.20E-04	6.06E-05
La-142	7.36E-10	2.69E-10	6.46E-11	0.00E+00	0.00E+00	5.87E-06	4.25E-05
Ce-141	1.98E-05	1.19E-05	1.42E-06	0.00E+00	3.75E-06	3.69E-04	1.54E-05
Ce-143	2.09E-07	1.38E-07	1.58E-08	0.00E+00	4.03E-08	8.30E-05	3.55E-05
Ce-144	2.28E-03	8.65E-04	1.26E-04	0.00E+00	3.84E-04	7.03E-03	1.06E-04
Pr-143	1.00E-05	3.74E-06	4.99E-07	0.00E+00	1.41E-06	3.09E-04	2.66E-05
Pr-144	3.42E-11	1.32E-11	1.72E-12	0.00E+00	4.80E-12	1.15E-06	3.06E-06
Nd-147	5.67E-06	5.81E-06	3.57E-07	0.00E+00	2.25E-06	2.30E-04	2.23E-05
W-187	9.26E-09	6.44E-09	2.23E-09	0.00E+00	0.00E+00	2.83E-05	2.54E-05
Np-239	2.65E-07	2.37E-08	1.34E-08	0.00E+00	4.73E-08	4.25E-05	1.78E-05

NOTE: The tritium dose factor for bone is assumed to be equal to the total body dose factor.

Reference:

Regulatory Guide 1.109, Table E-10.

Dose Factors for Co-57, Zn-69m, Br-82, Nb-97, Sn-125, Sb-124 and Sb-125 are from NUREG-0172 Age Specific Radiation Dose Commitment Factors for a One Year Chronic Intake, November 1977, Table 8.

Figure 7.1 GASEOUS EFFLUENT RELEASE POINTS

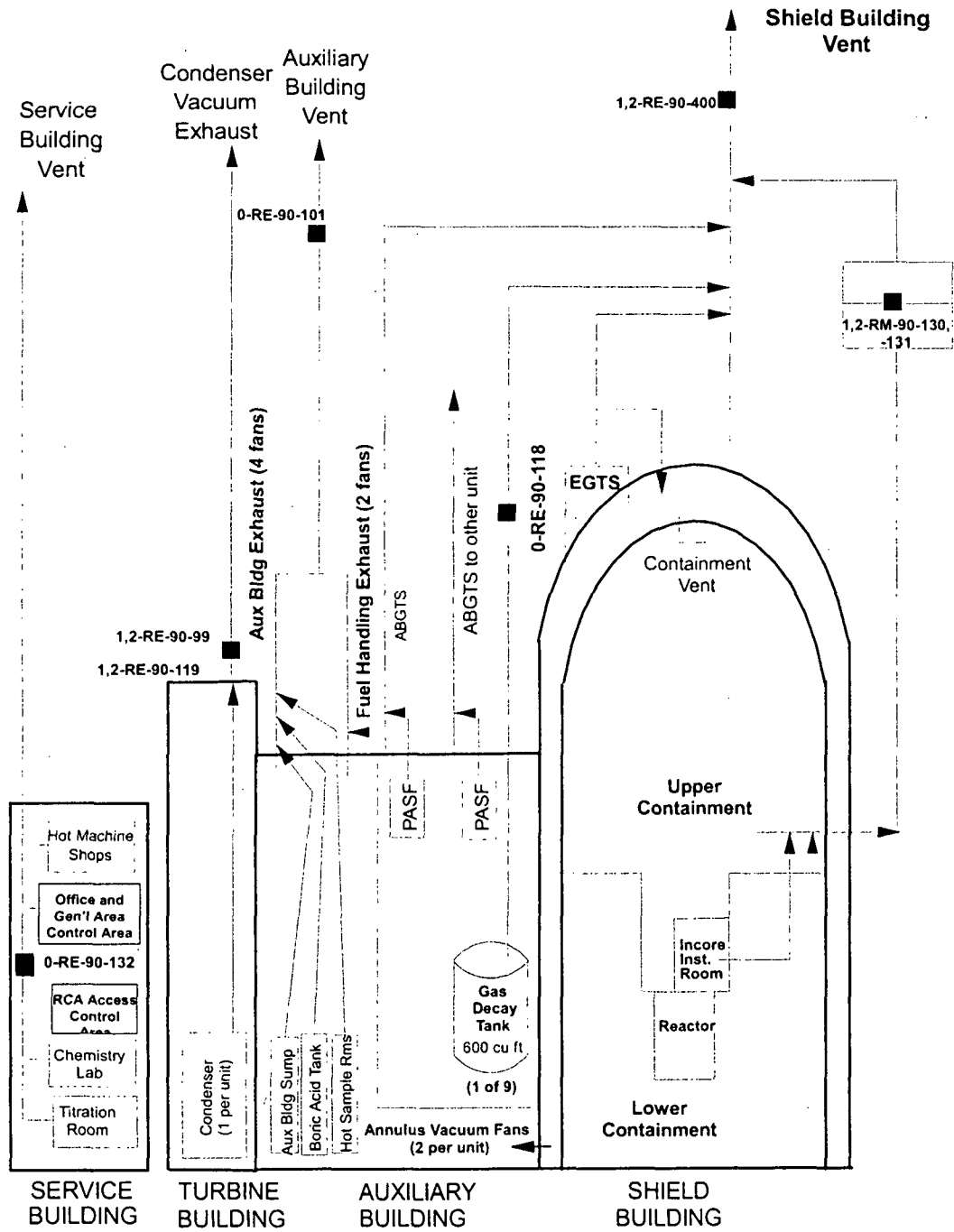

Figure 7.2 AUXILIARY AND SHIELD BUILDING VENTS (DETAIL)
(All Vents Are Considered Ground Level)

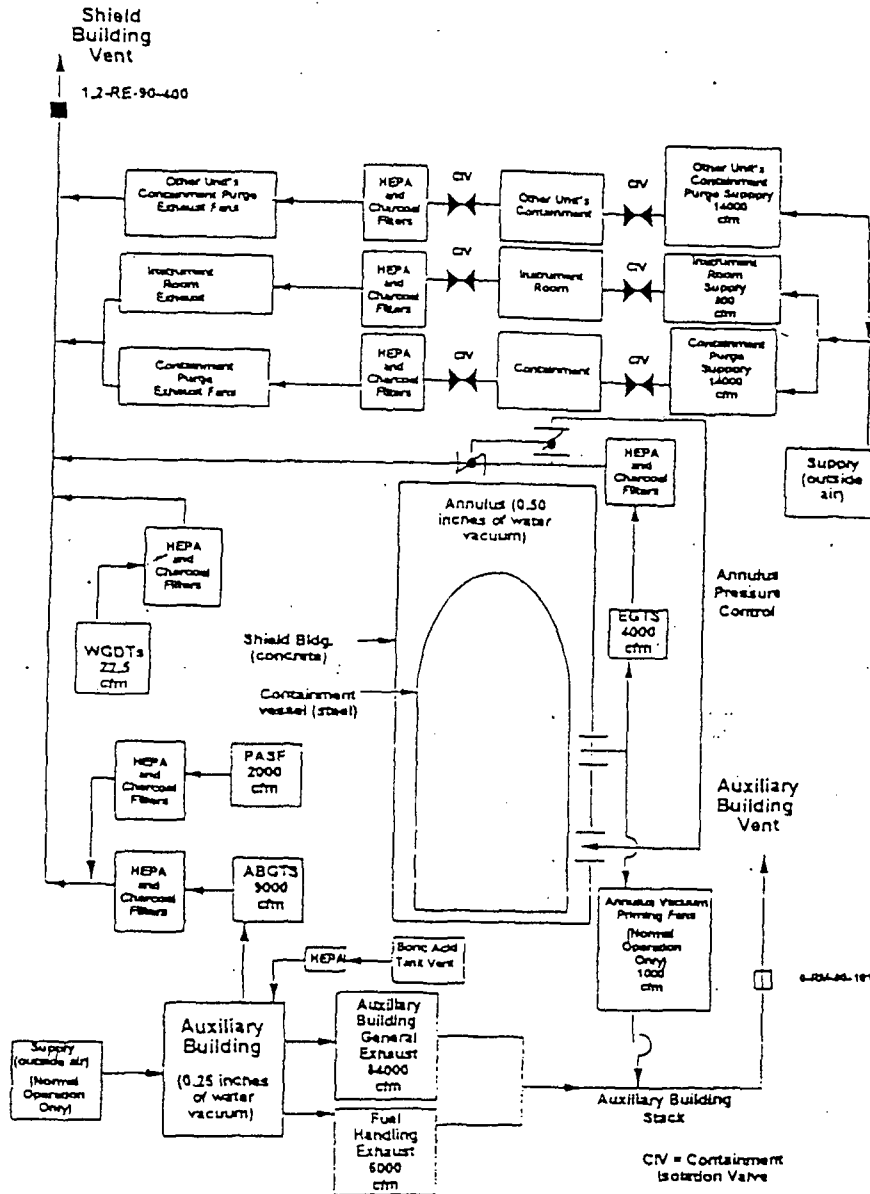

Figure 7.3 GASEOUS RADWASTE TREATMENT SYSTEM
(All Vents Are Considered Ground Level)

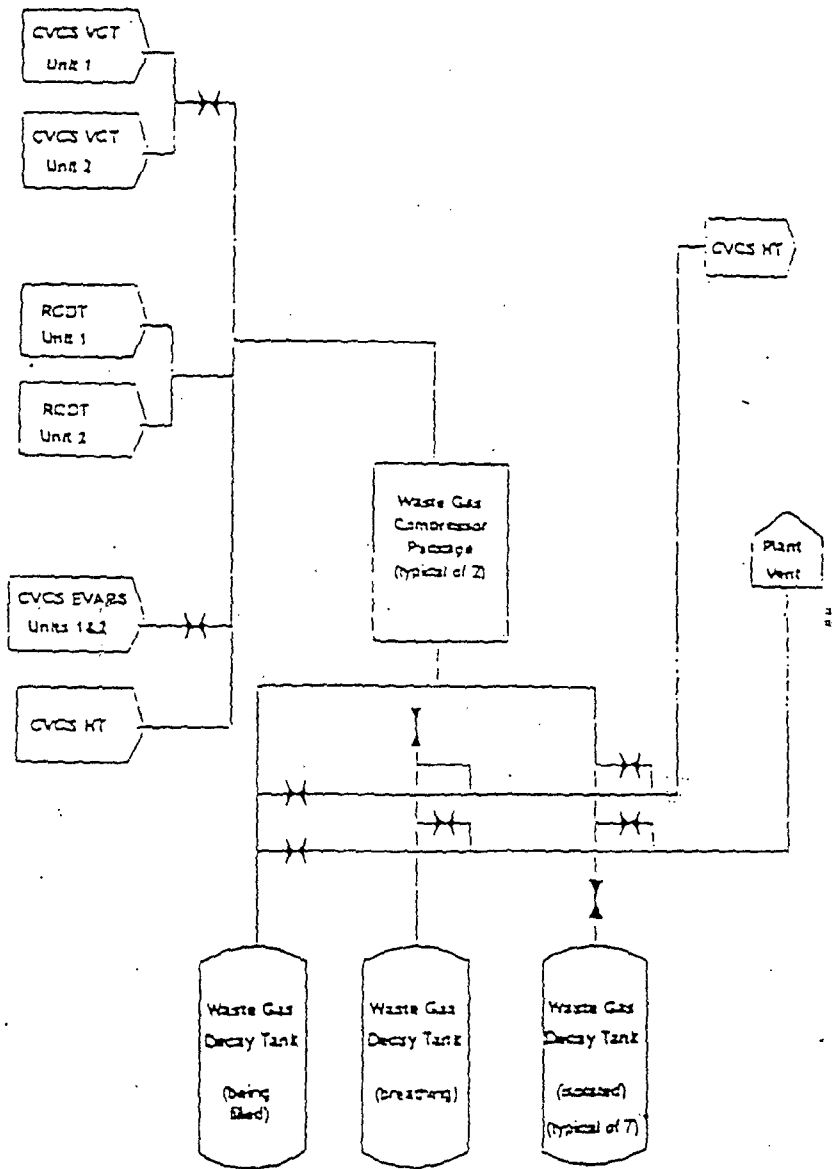

Figure 7.4 PLUME DEPLETION EFFECT FOR GROUND LEVEL RELEASES
(All Stability Classes)

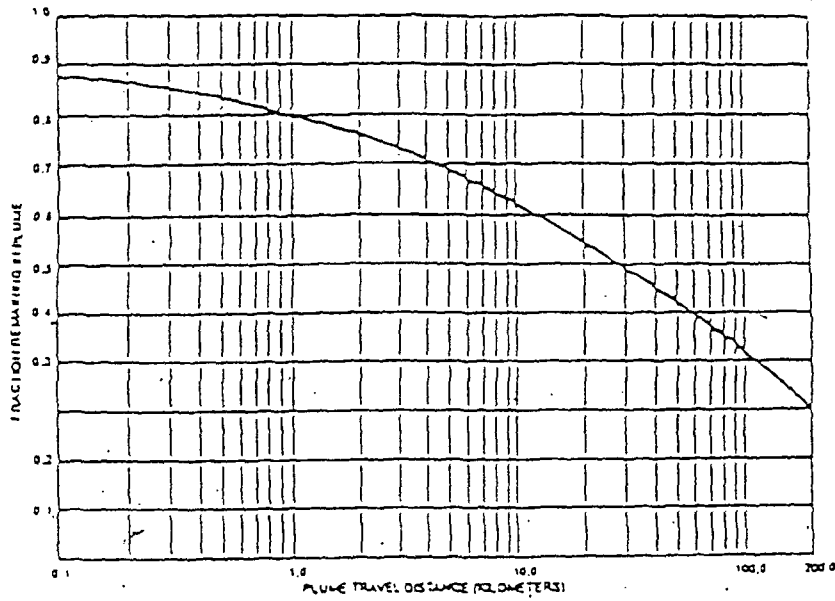
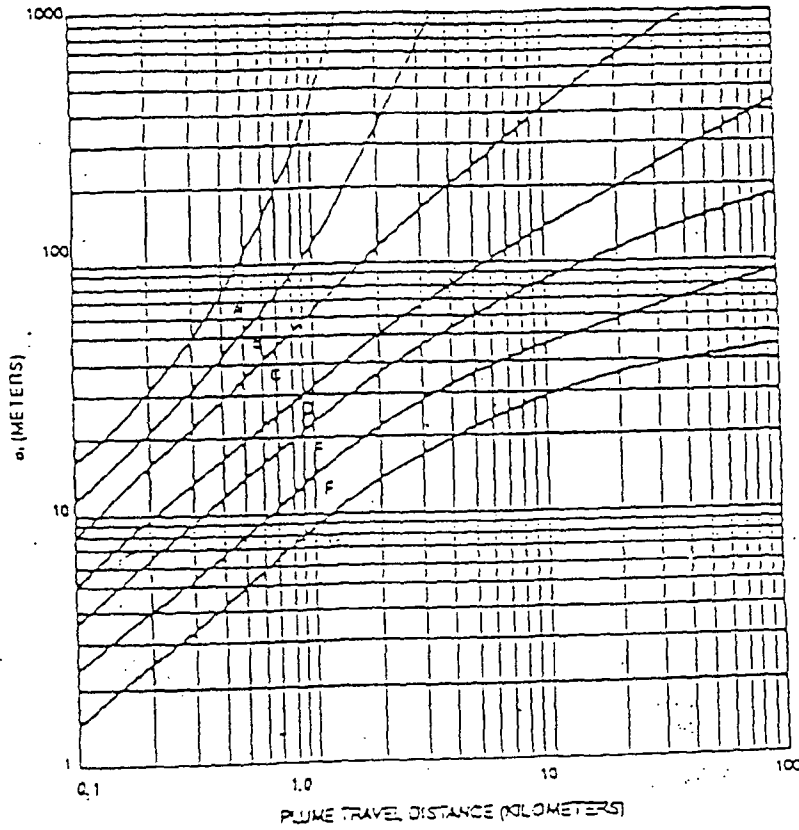
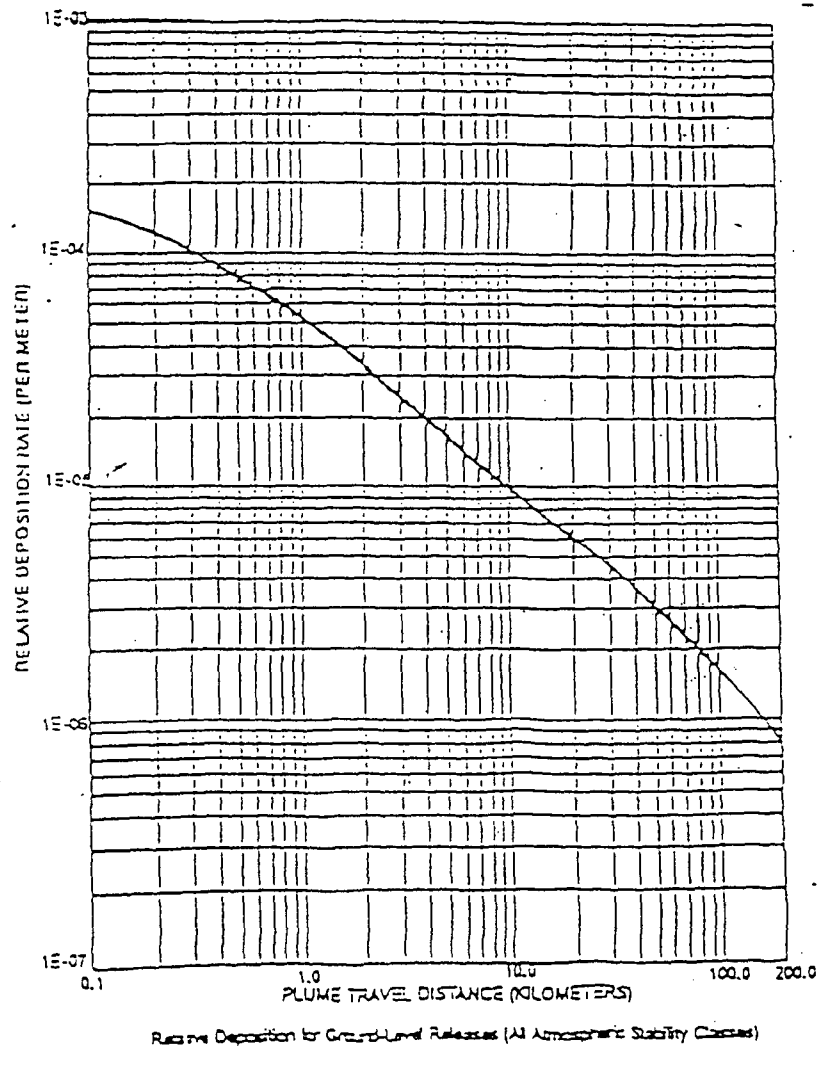

Figure 7.5 VERTICAL STANDARD DEVIATION OF MATERIAL IN A PLUME



Vertical Standard Deviation of Material in a Plume
(Letters denote Pasquill Stability Class)

Figure 7.6 RELATIVE DEPOSITION FOR GROUND LEVEL RELEASES
(All Stability Classes)



SECTION 8.0

TOTAL DOSE

SECTION 8.0 TOTAL DOSE

8.1 ANNUAL MAXIMUM INDIVIDUAL DOSES - TOTAL REPORTED DOSE

To determine compliance with 40 CFR 190 as required in ODCM Administrative Control 5.2, the annual dose contributions to the maximum individual from SQN radioactive effluents and all other nearby uranium fuel cycle sources will be considered. The annual dose to the maximum individual will be conservatively estimated by first, summing the quarterly total body air submersion dose, the quarterly critical organ dose from gaseous effluents, the quarterly total body dose from liquid effluents, the quarterly critical organ dose from liquid effluents, and the direct radiation monitoring program, and then taking the sum for each quarter and summing over the four quarters. The table below represents the above verbal description and relative values:

Dose	First Quarter	Second Quarter	Third Quarter	Fourth Quarter	
Total Body or any Organ (except thyroid)					
Total body air submersion	9.79E-04	9.00E-04	1.65E-03	4.27E-04	
Critical organ dose (air)	9.48E-03	9.40E-03	3.77E-03	9.37E-03	
Total body dose (liquid)	4.8E-03	2.1E-02	3.8E-02	6.5E-03	
Maximum organ dose (liquid)	5.8E-03	2.6E-02	5.0E-02	2.0E-02	
Direct Radiation Dose	0.0E-00	0.0E-00	0.0E-00	0.00E-00	
Total	2.1E-02	5.7E-02	9.3E-02	3.6E-02	
Cumulative Total Dose (Total body or any other organ) mrem					2.1E-01
Annual Dose Limit (mrem)					2.50E+01
Percent of Limit					<1%

SECTION 9.0

RADIOLOGICAL ENVIRONMENTAL MONITORING PROGRAM

SECTION 9.0 RADIOLOGICAL ENVIRONMENTAL MONITORING PROGRAM

9.1 MONITORING PROGRAM

An environmental radiological monitoring program shall be conducted in accordance with ODCM Control 1.3.1. The monitoring program described in Tables 9.1, 9.2, and 9.3, and in Figures 9.1, 9.2 and 9.3 shall be conducted. Results of this program shall be reported in accordance with ODCM Administrative Control 5.1.

The atmospheric environmental radiological monitoring program shall consist of monitoring stations from which samples of air particulates and atmospheric radioiodine shall be collected.

The terrestrial monitoring program shall consist of the collection of milk, soil, ground water, drinking water, and food crops. In addition, direct gamma radiation levels will be measured in the vicinity of the plant.

The reservoir sampling program shall consist of the collection of samples of surface water, sediment, clams, and fish.

Deviations are permitted from the required sampling schedule if specimens are unobtainable due to hazardous conditions, sample unavailability, or to malfunction of sampling equipment. If the latter, every effort shall be made to complete corrective action prior to the end of the next sampling period.

9.2 DETECTION CAPABILITIES

Analytical techniques shall be such that the detection capabilities listed in Table 2.3-3 are achieved.

9.3 LAND USE CENSUS

A land use survey shall be conducted in accordance with Control 1.3.2. The results of the survey shall be reported in the Annual Radiological Environmental Operating Report.

9.4 INTERLABORATORY COMPARISON PROGRAM

Analyses shall be performed on radioactive materials supplied as part of an Interlaboratory Comparison Program which has been approved by the NRC. A summary of the results obtained in the intercomparison shall be included in the Annual Radiological Environmental Operating Report (or the EPA program code designation may be provided).

If analyses are not performed as required corrective actions taken to prevent a recurrence shall be reported in the Annual Radiological Environmental Operating Report.

Table 9.1 RADIOLOGICAL ENVIRONMENTAL MONITORING PROGRAM
(Page 1 of 4)

Exposure Pathway and/or Sample	Sample Locations*	Sampling and Collection Frequency	Type and Frequency of Analysis
AIRBORNE			
Particulates	4 samples from locations (in different sectors) at or near the site boundary (LM-2,3,4,and 5) 4 samples from communities approximately 6-10 miles distance from the plant. (PM-2,3,8,and 9) 4 samples from control locations greater than 10 miles from the plant (RM-1,2,3,and 4)	Continuous sampler operation with sample collection once per 7 d (more frequently if required by dust loading)	Analyze for gross beta radioactivity \geq 24 hours following filter change. Perform gamma isotopic analysis on each sample if gross beta > 10 times yearly mean of control sample. Composite at least once per 31 d (by location for gamma scan)
Radioiodine	Samples from same location as air particulates	Continuous sampler operation with filter collection once per 7 d	I-131 at least once per 7 d
Soil	Samples from same locations as air particulates	Once per year	Gamma scan, Sr-89, Sr-90 once per year
DIRECT RADIATION			
	2 or more TLD's placed at locations (in different sectors at or near the site boundary) in each of the 16 sectors.	Once per 92 d	Gamma dose at least once per 92 d

* Sample locations are listed in Tables 9.2 and 9.3 and shown on Figures 9.1, 9.2 and 9.3

Table 9.1 RADIOLOGICAL ENVIRONMENTAL MONITORING PROGRAM
(Page 2 of 4)

Exposure Pathway and/or Sample	Sample Locations*	Sampling and Collection Frequency	Type and Frequency of Analysis
DIRECT RADIATION (continued)			
	2 or more TLD's placed at stations located approximately 5 miles from the plant in each of the 16 sectors 2 or more dosimeters in at least 8 additional locations of special interest.		
WATERBORNE			
Surface	TRM 503.8*** TRM 483.4	Collected by automatic sequential type sampler** with composite samples collected at least once per 31 d.	Gamma scan of each composite sample. Composite for H-3 analysis at least once per 92 d.
Ground	1 sample adjacent to plant (location W-6) 1 sample from groundwater source up-gradient	At least once per 92 d	Gross beta and gamma scan and H-3 analysis at least once per 92 d.

* Sample locations are listed in Tables 9.2 and 9.3 and shown on Figures 9.1, 9.2 and 9.3

** Samples shall be collected by collecting an aliquot at intervals not exceeding 2 hours.

*** Sample used as control for surface water and drinking water.

Table 9.1 RADIOLOGICAL ENVIRONMENTAL MONITORING PROGRAM
(Page 3 of 4)

Exposure Pathway and/or Sample	Sample Locations*	Sampling and Collection Frequency	Type and Frequency of Analysis
WATERBORNE (continued)			
Drinking	1 sample at the first potable water supply downstream from the plant (TRM 473.0)	Collected by automatic sequential type sampler** with composite samples collected at least once per 31 d	Gross beta and gamma scan of each composite sample. Composite for H-3, at least once per 92 d.
	1 sample at the next 2 downstream potable surface water supplies (greater than 10 miles downstream) (TRM 469.9 and 465.3)	Grab sample once per 31 d.	
	1 sample at a control location upstream from the plant (TRM 503.8)***	Samples collected by automatic sequential type sampler** with composite sample collected at least once per 31 d.	
Shoreline Sediment	TRM 485, TRM 480, TRM 479	At least once per 184 d	Gamma scan of each sample.
INGESTION			
Milk	1 sample from milk producing animals in each of 1-3 areas indicated by the cow census where doses are calculated to be highest. If samples are not available from a milk animal location, doses to that area will be estimated by projecting the doses from concentrations detected in milk from other sectors or samples of vegetation will be taken monthly when milk is not available. At least 1 sample from a control location.	At least once per 15 d.	Gamma isotopic and I-131 analysis of each sample. Sr-89, Sr-90 once per year.

* Sample locations are listed in Tables 9.2 and 9.3 and shown on Figures 9.1, 9.2 and 9.3

** Samples shall be collected by collecting an aliquot at intervals not exceeding 2 hours.

*** Sample location is considered a control for drinking water and surface water.

Table 9.1 RADIOLOGICAL ENVIRONMENTAL MONITORING PROGRAM
(Page 4 of 4)

Exposure Pathway and/or Sample	Sample Locations*	Sampling and Collection Frequency	Type and Frequency of Analysis
INGESTION			
Fish	1 sample each from Chickamauga and Watts Bar Reservoirs.	At least once per 184 d. One sample representing a commercially important species and one sample representing a recreationally important species.	Gamma scan on edible portion.
Food Products	1 sample each of principle food products grown at private gardens and/or farms in the vicinity of the plant.	At least once per 365 d at time of harvest. The types of foods available for sampling will vary. Following is a list of typical foods which may be available: Cabbage and/or lettuce Corn Green Beans Potatoes Tomatoes	Gamma scan on edible portion.
Vegetation**	Samples from farms producing milk but not providing a milk sample Control Sample from one control dairy farm	At least once per 31 d	I-131 and gamma scan at least once per 31 d

* Sample locations are listed in Tables 9.2 and 9.3 and shown on Figures 9.1, 9.2 and 9.3

** Vegetation sampling is applicable only for farms that meet the criteria for milk sampling and when implementation of milk sampling is not possible.

Table 9.2 ENVIRONMENTAL RADIOLOGICAL MONITORING PROGRAM SAMPLING LOCATIONS

Map Location Number ^a	Station	Sector	Approximate Distance	Indicator (I) or Control	Samples Collected ^b
2	LM-2	N	0.7	I	AP, CF, S
3	LM-3	SSW	2.0	I	AP, CF, S
4	LM-4	NE	1.5	I	AP, CF, S
5	LM-5	NNE	1.8	I	AP, CF, S
7	PM-2	SW	3.8	I	AP, CF, S
8	PM-3	W	5.6	I	AP, CF, S
9	PM-8	SSW	8.7	I	AP, CF, S
10	PM-9	WSW	2.6	I	AP, CF, S
11	RM-1	SW	16.7	C	AP, CF, S
12	RM-2	NNE	17.8	C	AP, CF, S
13	RM-3	ESE	11.3	C	AP, CF, S
14	RM-4	NW	20.0	C	AP, CF, S
19	Farm HW	NW	1.2	I	M, W ^c
21	Farm HS	E	4.6	I	M
23	Farm EH	ENE	9.5	C	M
24	Well No. 6	NNE	0.15	I	W
25	Farm K	NE	40	C	M
31	TRM 473.0 East Side Utility (Formerly C. F. Industries)	--	10.7 ^e	I	PW
32	TRM 469.9 (E. I. DuPont)	--	13.8 ^e	I	PW
33	TRM 465.3 (Chattanooga)	--	18.4 ^e	I	PW
34	Deleted (R 40)				
35	TRM 503.8 (Dayton)	--	20.1 ^e	C ^f	SW, PW
37	TRM 485.0	--	1.3 ^e	C	SS
38	TRM 483.4	--	0.3	I	SW
40	TRM 479.0	--	4.7 ^e	I	SS
44	TRM 480.0	--	3.7 ^e	I	SS
46	Chickamauga Reservoir	--		I	F
47	Watts Bar Reservoir	--	--	C	F

^a See figures 9.1, 9.2, and 9.3

^b Sample Codes: AP = Air particulate filter CF = Charcoal filter F = Fish
M = Milk PW = Public water R = Rainwater S = Soil

^c SS = Shoreline sediment SW = Surface water W = Well water

^d A control for well water.

^e TRM = Tennessee River Mile.

^f Distance from plant discharge (TRM 483.7) in river miles.

Sample also used as a control for public water and surface water.

Table 9.3 THERMOLUMINESCENT DOSIMETRY LOCATIONS
(Page 1 of 2)

<u>Map Location Number</u>	<u>Station</u>	<u>Sector</u>	<u>Approximate Distance (Miles)</u>	<u>(Onsite)a or Offsite (Off)</u>
3	SSW-1C	SSW	2.0	On
4	NE-1A	NE	1.5	On
5	NNE-1	NNE	1.8	On
7	SW-2	SW	3.8	Off
8	W-3	W	5.6	Off
9	SSW-3	SSW	8.7	Off
10	WSW-2A	WSW	2.6	Off
11	SW-3	SW	16.7	Off
12	NNE-4	NNE	17.8	Off
13	ESE-3	ESE	11.3	Off
14	NW-3	NW	20.0	Off
49	N-1	N	0.6	On
50	N-2	N	2.1	Off
51	N-3	N	5.2	Off
52	N-4	N	10.0	Off
53	NNE-2	NNE	5.3	Off
55	NE-1	NE	2.4	Off
56	NE-2	NE	4.1	Off
57	ENE-1	ENE	0.2	On
58	ENE-2	ENE	5.1	Off
59	E-1	E	1.2	On
60	E-2	E	5.2	Off
62	ESE-1	ESE	1.2	On
63	ESE-2	ESE	4.9	Off
66	SE-1	SE	1.4	On
67	SE-2	SE	1.9	On
68	SE-4	SE	5.2	Off
69	SSE-1	SSE	1.6	On
70	SSE-2	SSE	4.6	Off
71	S-1	S	1.5	On
72	S-2	S	4.7	Off
73	SSW-1	SSW	0.6	On
74	SSW-2	SSW	4.0	Off

^aTLDs designated onsite are those located two miles or less from the plant.
TLDs designated offsite are those located more than two miles from the plant.

Table 9.3 THERMOLUMINESCENT DOSIMETRY LOCATIONS
(Page 2 of 2)

<u>Map Location Number</u>	<u>Station</u>	<u>Sector</u>	<u>Approximate Distance (Miles)</u>	<u>Onsite (On)^a or Offsite (Off)</u>
75	SW-1	SW	0.7	On
76	WSW-1	WSW	0.9	On
77	WSW-2	WSW	2.5	Off
78	WSW-3	WSW	5.7	Off
79	WSW-4	WSW	7.8	Off
81	W-1	W	0.6	On
82	W-2	W	4.3	Off
83	WNW-1	WNW	0.4	On
84	WNW-2	WNW	5.3	Off
85	NW-1	NW	0.4	On
86	NW-2	NW	5.2	Off
87	NNW-1	NNW	0.6	On
88	NNW-2	NNW	1.7	On
89	NNW-3	NNW	5.3	Off
90	SSW-1B	SSW	1.5	On

^aTLDs designated onsite are those located two miles or less from the plant.
TLDs designated offsite are those located more than two miles from the plant.

Figure 9.1 ENVIRONMENTAL MONITORING LOCATIONS WITHIN ONE MILE OF THE PLANT

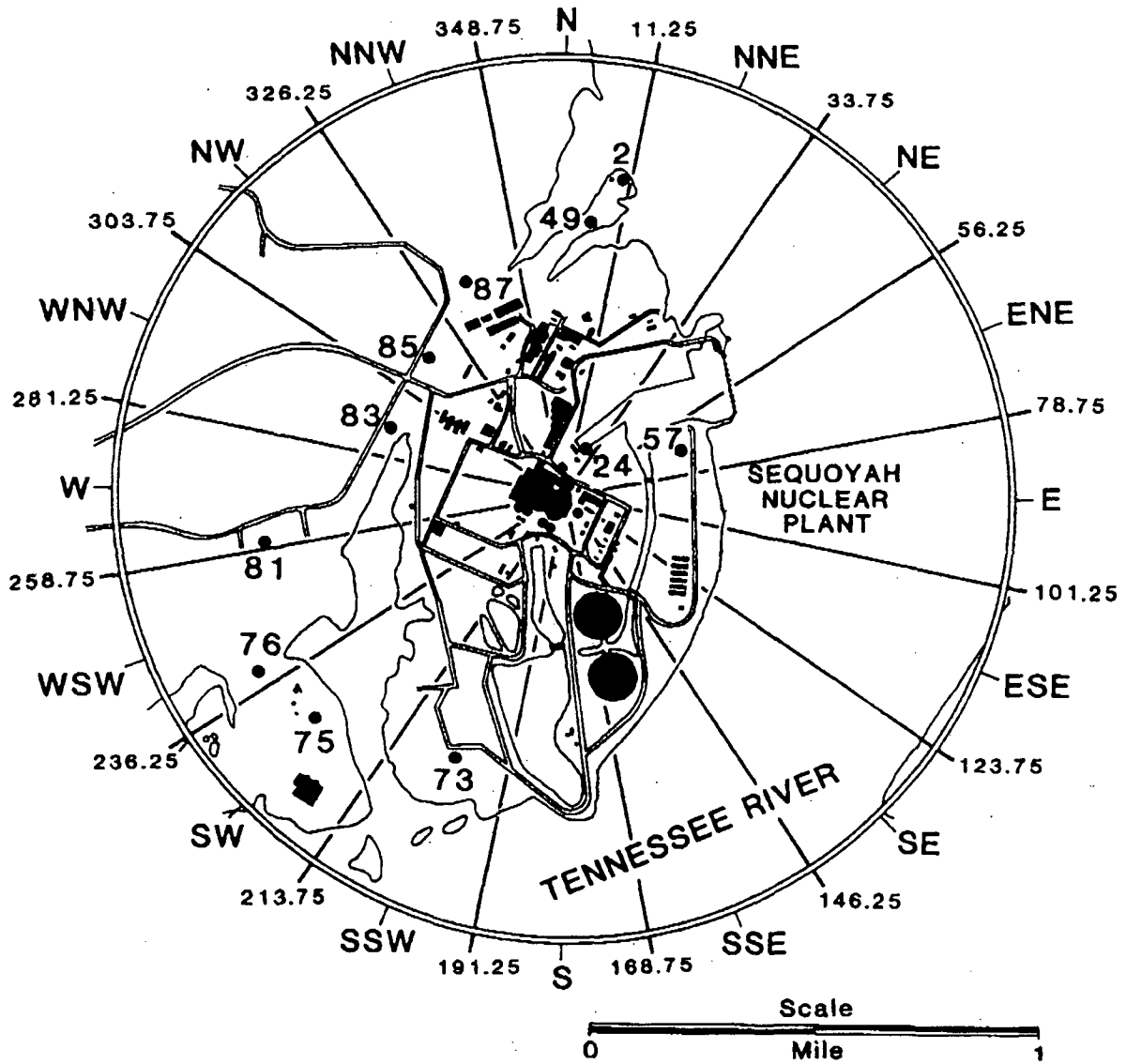

Figure 9.2 ENVIRONMENTAL MONITORING LOCATIONS FROM ONE TO FIVE MILES FROM THE PLANT

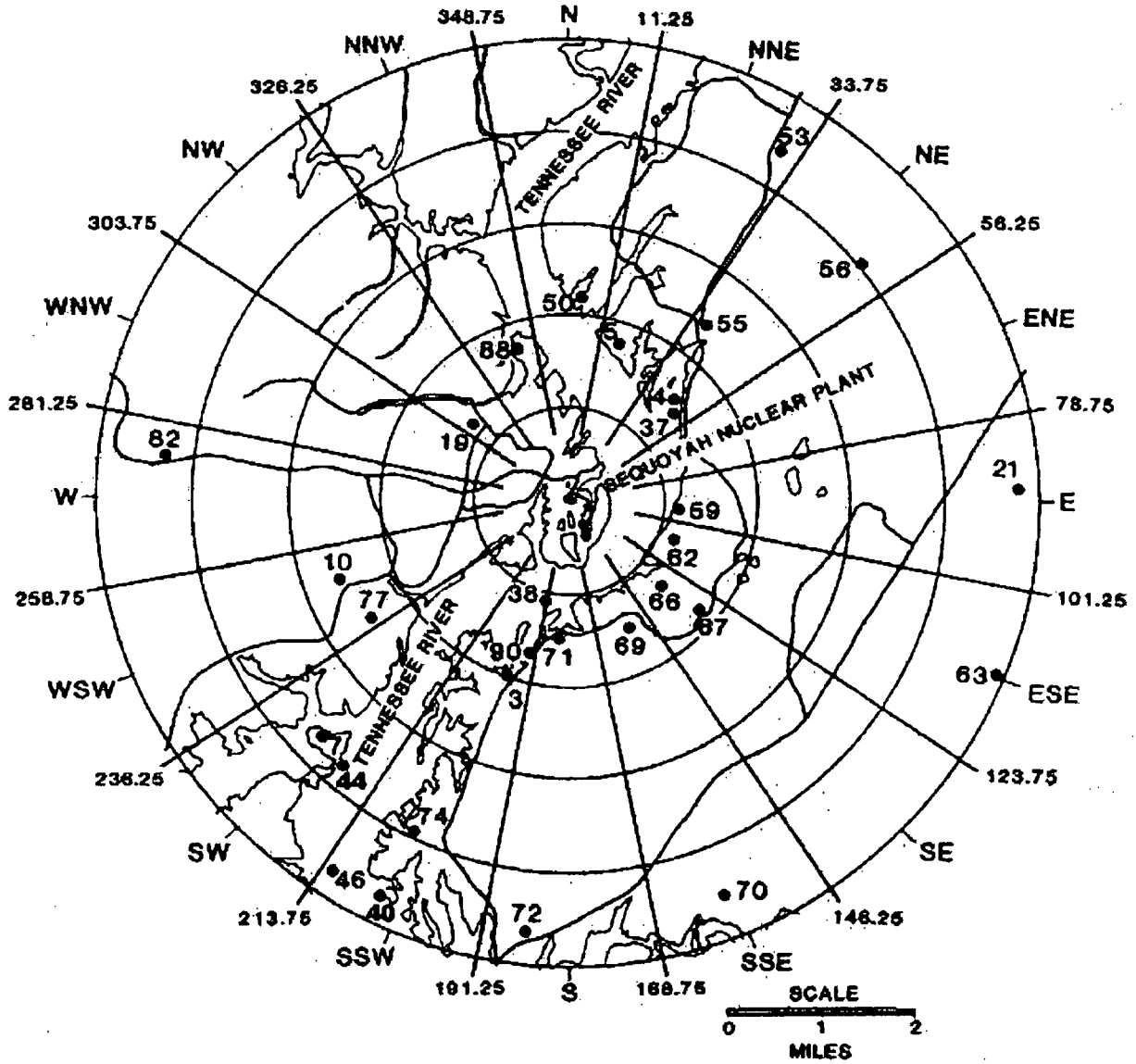
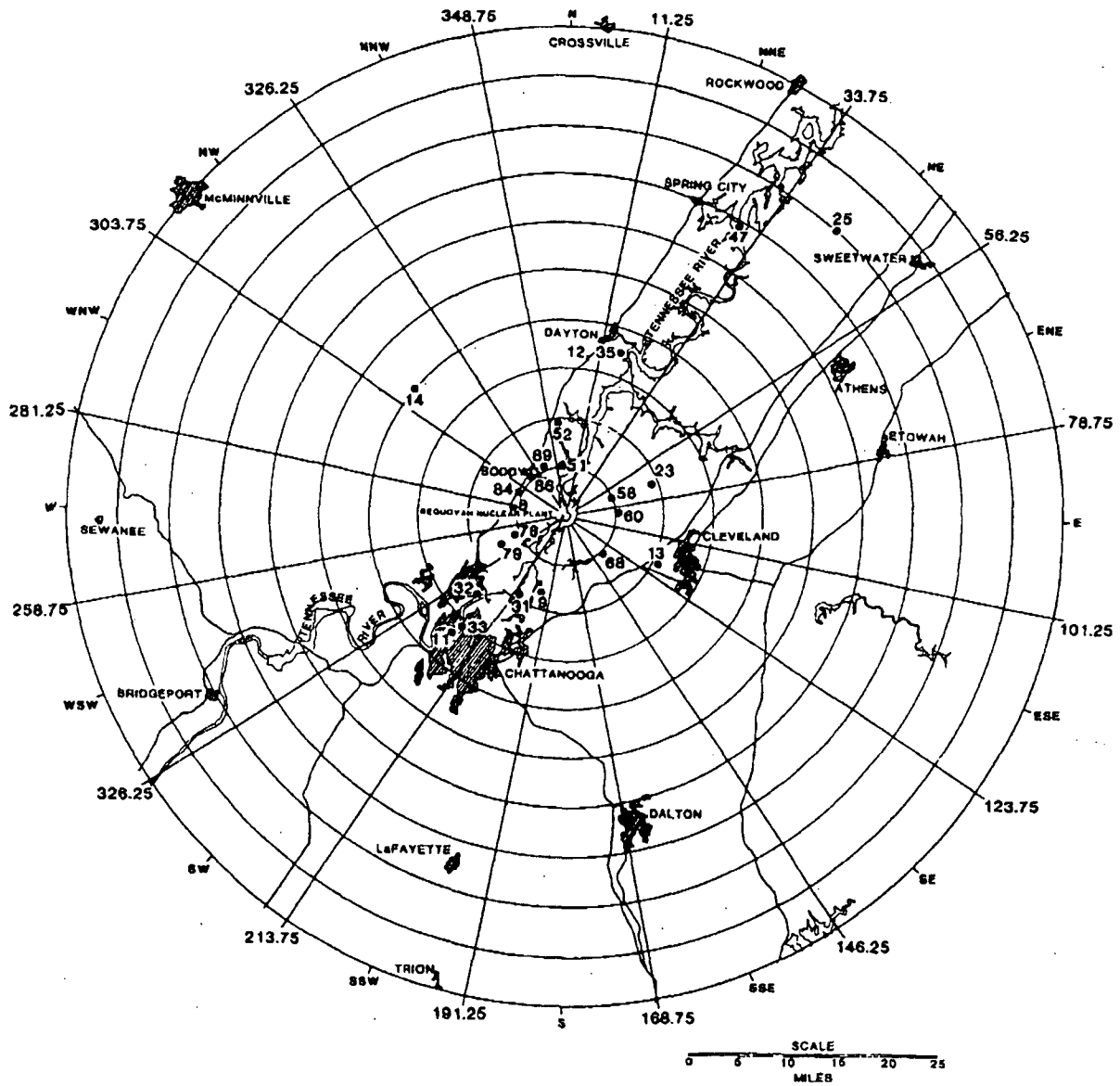

Figure 9.3 ENVIRONMENTAL MONITORING LOCATIONS GREATER THAN FIVE MILES FROM THE PLANT



APPENDIX A - SQN ODCM REVISION PROCESS

(Page 1 of 7)

This Appendix establishes the minimum requirements for preparation, review, and approval of the Sequoyah Nuclear Plant Offsite Dose Calculation Manual. This Appendix also implements the requirements of ODCM Section 5.3 and SQN TS.

1.0 Reviewer Responsibilities

1.1 Affected Organization Review (AOR)

The identification of affected organizations is the responsibility of the Sponsor and applies to all revisions of the ODCM.

The affected organizations shall ensure that their reviewers have adequate understanding of the requirements and intent of the ODCM and access to pertinent background information.

The AO reviews the draft for impact on the organization and adequate interface - not technical content.

1.2 Independent Qualified Review (IQR)

An independent qualified review is the process of independent technical review by Qualified Reviewers of activities potentially affecting nuclear safety.

The IQR shall NOT be the person who prepared the ODCM revision.

An IQR is performed by an individual designated by responsible department level managers to perform an independent technical review of activities potentially affecting nuclear safety.

The IQR must be qualified to perform 10 CFR 50.59 review.

1.3 Cross Disciplinary Review (CDR)

The need for a CDR is determined by the IQR.

CDR is a technical review by disciplines other than those responsible for the document preparation.

The CDR is responsible for only the technical aspects of the areas specified by the IQR and any portions of the document that support or justify those areas.

Persons performing CDR do not have to be IQR qualified.

1.4 Plant Operations Review Committee (PORC) Review

The PORC reviews the ODCM.

APPENDIX A - SQN ODCM REVISION PROCESS

(Page 2 of 7)

1.5 Approval Authority

The Plant Manager or designee will approve all revisions to the ODCM as required by Technical Specifications.

2.0 Processing ODCM Revisions

2.1 Requester (If other than the Sponsor)

Identify the need for an ODCM improvement.

Prepare a justification for the ODCM revision.

Attach a marked-up copy of the existing ODCM.

Forward the requested ODCM revision to the sponsoring organization.

2.2 ODCM Sponsor

Evaluate requested changes and determine if necessary.

If the requested change is not necessary, return the request to the requester with explanation why the change is not needed.

Incorporate all changes in a draft revision on BSL.

Complete the top portion of Attachment B for each organization.

Distribute Attachment B to each Affected Organization and request completion of the review prior to expected PORC review date.

Obtain appropriate reviews of the ODCM revision in BSL.

2.3 Reviews

2.3.1 IQR

Review the ODCM using all questions on Attachment C as a guideline and forward comments to the Sponsor.

Identify discipline or organization to perform CDR, if needed.

APPENDIX A - SQN ODCM REVISION PROCESS (Page 3 of 7)

2.3.2 Affected Organization Reviewer

Review the proposed changes on BSL and provide comments to the ODCM Sponsor.

Review the ODCM for impact on assigned organization, identify procedures/documents which require revision to implement the ODCM revision on the Attachment B, and return the Attachment B to the ODCM Sponsor.

2.4 Sponsor

If revision includes surveillance requirement or performance frequency changes then review SI/SR matrix for impact.

Resolve comments and obtain reviewer's concurrence in BSL. Escalate any unresolved comments to appropriate management.

Ensure ODCM has been reviewed by sponsor and IQR in accordance with Attachment C.

Ensure all Affected Organizations have reviewed the ODCM change and have identified the affected procedures on Attachment B.

Ensure all IQR and CDR review requirements have been met.

Assign an Effective Date typically 60 calendar days forward UNLESS there is reasonable justification for making it effective earlier, such as plant operating conditions, test schedules, commitment or corrective action deadlines, or implementation of upper-tier requirements, or lack of affected procedures identified on Attachment B.

2.5 PORC

Review Changes and document recommendation for approval in BSL.

2.6 Plant Manager

Approve the ODCM revision in BSL.

2.7 ODCM Sponsor

Record the ODCM approval date and implementation date on each completed Attachment B provided by the affected organizations.

Return the Attachment B to each affected organization.

2.8 Affected Organization

Revise procedures identified on the Attachment B and assign an effective date which matches that of the ODCM revision.

Complete the Attachment B and return to the ODCM Sponsor.

APPENDIX A - SQN ODCM REVISION PROCESS
(Page 4 of 7)

2.9 ODCM Sponsor

Ensure all Affected Organizations have completed and returned Attachment B prior to the effective date of the ODCM.

Forward the approved ODCM change to Management Services at least three working days before the implementation date.

The completed Attachments B and C are QA records, and are handled in accordance with the Document Control and Records Management Program.

Forward a completed copy of each revision to Licensing to be filed and forwarded to the NRC in the Annual Radiological Effluent Release Report.

2.10 Management Services

Issue the ODCM and implementing procedures on the effective date of the ODCM revision.

APPENDIX A - SQN ODCM REVISION PROCESS
(Page 6 of 7)

Attachment C

ODCM Review Checklist

All questions of this checklist are considered by the ODCM preparer and reviewed by the Independent Qualified Reviewer (IQR). Only the revised portion of the ODCM should be evaluated.

	Changes to Section(s) 1.0-5.0	YES	NO	N/A
1.	Does the revision meet the intent of the guidance provided in NUREG-1301 for radiological effluent and environmental monitoring controls/surveillance requirements?			
2.	Do definitions in Section 3.0 match those provided in the SQN TS, NUREG-1301, or other NRC guidance?			
3.	Do Administrative Controls in Section 5.0 match those provided in SQN TS, NUREG-1301, or other NRC guidance?			
4.	Does the ODCM fulfill the requirements of TVA, Federal or State Laws, SQN FSAR, and any other referenced requirements documents?			
5.	Does the numbering of the Control and its accompanying Surveillance Requirement correspond?			
6.	Are instrument/equipment numbers and units of measure an exact match with those on the equipment?			
7.	Does nomenclature accurately describe the equipment and correspond to label identifiers?			
8.	Are referenced documents applicable, valid, and listed in the reference section?			
9.	Does this change maintain the level of radioactive effluent control required by 10 CFR Part 20.1302, 40 CFR Part 190, 1- CFR Part 50.36a, and Appendix I to 10 CFR Part 50? Provide justification for answer:			
10.	Are there methodologies given in Sections 6.0 through 9.0 which implement the applicable ODCM Controls?			
11.	Are references to ODCM Controls and Surveillance Requirements accurate and correct?			
12.	Are changes to setpoint calculation methodologies consistent with the guidance provided in NUREG-0133?			

APPENDIX A - SQN ODCM REVISION PROCESS
(Page 7 of 7)
Attachment C

ODCM Review Checklist (continued)

	Changes to Section(s) 6.0-11.0	YES	NO	N/A
13.	Are changes to liquid effluent concentration compliance methodologies consistent with the guidance provided in NUREG-0133 and 10 CFR Part 20?			
14.	Are changes to gaseous effluent dose rate calculation/compliance methodologies consistent with the guidance provided in NUREG-0133 and/or Regulatory Guide 1.109?			
15.	Are changes to dose or dose projection calculation/compliance methodologies consistent with the guidance provided in NUREG-0133 and/or Regulatory Guide 1.109?			
16.	Are instrument/equipment numbers and units of measure an exact match with those on the equipment?			
17.	Are referenced documents applicable, valid, and listed in the references?			
18.	Are ODCM Sections numbered consistently and consecutively?			
19.	Are references to other ODCM Sections correct?			
20.	Are references to ODCM Tables and Figures accurate and correct?			
21.	Are any new acronyms defined in Appendix A?			
22.	Are equations numbered consecutively?			
23.	Does dimensional analysis yield the correct units for equations?			
24.	Are terms used in equations defined after the equation (and in Appendix A) and the proper units given for that term?			
25.	Do units on equation terms which reference tables match the units used for that term in the Table?			{
26.	Are references given for table and other values correct and accurate?			
27.	Do data values given match those in the reference?			
28.	Do text descriptions of release/discharge points in Sections 6.0 and 7.0 correspond with the Figures referenced in those sections?			
29.	The change does not adversely impact the accuracy or reliability of effluent, dose, or setpoint calculations? Provide justification for answer:			

_____/_____
Preparer Date

_____/_____
IQR Date