

**UNITED STATES NUCLEAR REGULATORY COMMISSION
PRESSURIZED WATER REACTOR GENERIC FUNDAMENTALS EXAMINATION
DECEMBER 2006--FORM A**

Please Print

Name: _____

Docket No.: _____

Facility: _____

Start Time: _____ Stop Time: _____

INSTRUCTIONS TO APPLICANT

Answer all the test items using the answer sheet provided, ensuring a single answer is marked for each test item. Each test item has equal point value. A score of at least 80% is required to pass this portion of the NRC operator licensing written examination. All examination papers will be collected 3.0 hours after the examination starts. This examination applies to a typical pressurized water reactor (PWR) nuclear power plant.

SECTION	QUESTIONS	% OF TOTAL	SCORE
COMPONENTS	1 - 22		
REACTOR THEORY	23 - 36		
THERMODYNAMICS	37 - 50		
TOTALS	50		

All work performed on this examination is my own. I have neither given nor received aid.

Applicant's Signature

**RULES AND GUIDELINES FOR THE NRC
GENERIC FUNDAMENTALS EXAMINATION**

During the administration of this examination the following rules apply:

NOTE: The generic term "control rod" refers to the length of neutron absorber material that can be positioned by the operator to change core reactivity.

1. Print your name in the blank provided on the cover sheet of the examination.
2. Fill in your individual docket number.
3. Fill in the name of your facility.
4. Fill in your start and stop times at the appropriate time.
5. Two aids are provided for your use during the examination:
 - (1) An equations and conversions sheet contained within the examination copy, and
 - (2) Steam tables and Mollier Diagram provided by your proctor.
6. Place your answers on the answer sheet provided. Credit will only be given for answers properly marked on this sheet. Follow the instructions for filling out the answer sheet.
7. Scrap paper will be provided for calculations.
8. Cheating on the examination will result in the automatic forfeiture of this examination. Cheating could also result in severe penalties.
9. Restroom trips are limited. Only **ONE** examinee may leave the room at a time. In order to avoid the appearance or possibility of cheating, avoid all contact with anyone outside of the examination room.
10. After you have completed the examination, sign the statement on the cover sheet indicating that the work is your own and you have neither given nor received any assistance in completing the examination. Either pencil or pen may be used.
11. Turn in your examination materials, answer sheet on top, followed by the examination booklet, then examination aids - steam table booklets, handouts, and scrap paper used during the examination.
12. After turning in your examination materials, leave the examination area, as defined by the proctor. If after leaving you are found in the examination area while the examination is in progress, your examination may be forfeited.

GENERIC FUNDAMENTALS EXAMINATION
EQUATIONS AND CONVERSIONS HANDOUT SHEET

EQUATIONS

$$\dot{Q} = \dot{m}c_p\Delta T$$

$$\dot{Q} = \dot{m}\Delta h$$

$$\dot{Q} = UA\Delta T$$

$$\dot{Q} \propto \dot{m}_{\text{Nat Circ}}^3$$

$$\Delta T \propto \dot{m}_{\text{Nat Circ}}^2$$

$$K_{\text{eff}} = 1/(1 - \rho)$$

$$\rho = (K_{\text{eff}} - 1)/K_{\text{eff}}$$

$$\text{SUR} = 26.06/\tau$$

$$\tau = \frac{\bar{\beta} - \rho}{\lambda_{\text{eff}} \rho}$$

$$\rho = \frac{\ell^*}{\tau} + \frac{\bar{\beta}}{1 + \lambda_{\text{eff}}\tau}$$

$$\ell^* = 1 \times 10^{-4} \text{ sec}$$

$$\lambda_{\text{eff}} = 0.1 \text{ sec}^{-1} \text{ (for small positive } \rho)$$

$$\text{DRW} \propto \phi_{\text{tip}}^2 / \phi_{\text{avg}}^2$$

$$P = P_o 10^{\text{SUR}(t)}$$

$$P = P_o e^{(t/\tau)}$$

$$A = A_o e^{-\lambda t}$$

$$\text{CR}_{\text{S/D}} = S/(1 - K_{\text{eff}})$$

$$\text{CR}_1(1 - K_{\text{eff}1}) = \text{CR}_2(1 - K_{\text{eff}2})$$

$$1/M = \text{CR}_1/\text{CR}_x$$

$$A = \pi r^2$$

$$F = PA$$

$$\dot{m} = \rho A \bar{v}$$

$$\dot{W}_{\text{Pump}} = \dot{m}\Delta P v$$

$$E = IR$$

$$\text{Eff.} = \text{Net Work Out/Energy In}$$

$$\frac{g(z_2 - z_1)}{g_c} + \frac{(\bar{v}_2^2 - \bar{v}_1^2)}{2g_c} + v(P_2 - P_1) + (u_2 - u_1) + (q - w) = 0$$

$$g_c = 32.2 \text{ lbf-ft/lbf-sec}^2$$

CONVERSIONS

$$1 \text{ Mw} = 3.41 \times 10^6 \text{ Btu/hr}$$

$$1 \text{ hp} = 2.54 \times 10^3 \text{ Btu/hr}$$

$$1 \text{ Btu} = 778 \text{ ft-lbf}$$

$$^\circ\text{C} = (5/9)(^\circ\text{F} - 32)$$

$$^\circ\text{F} = (9/5)(^\circ\text{C}) + 32$$

$$1 \text{ Curie} = 3.7 \times 10^{10} \text{ dps}$$

$$1 \text{ kg} = 2.21 \text{ lbf}$$

$$1 \text{ gal}_{\text{water}} = 8.35 \text{ lbf}$$

$$1 \text{ ft}^3_{\text{water}} = 7.48 \text{ gal}$$

**USNRC GENERIC FUNDAMENTALS EXAMINATION
DECEMBER 2006 PWR--FORM A**

QUESTION: 1

A completely full water storage tank is being hydrostatically tested to 100 psig using a positive displacement pump (PDP) with a smooth and constant discharge flow rate of 10 gpm. The tank is protected by a safety valve and a relief valve; both valves will discharge to the atmosphere. Each valve has an opening setpoint of 105 psig and a maximum rated discharge flow rate of 6 gpm. The PDP is inadvertently left running when tank pressure reaches 100 psig.

With the PDP still running, tank pressure will stabilize _____ 105 psig; the greater mass flow rate will be coming from the _____ valve.

- A. at; safety
- B. above; safety
- C. at; relief
- D. above; relief

**USNRC GENERIC FUNDAMENTALS EXAMINATION
DECEMBER 2006 PWR--FORM A**

QUESTION: 2

Refer to the drawing of a pneumatically-operated valve (see figure below). The valve actuator may be shown with or without air pressure applied to it.

Which one of the following describes the type of valve shown, and the fail position on loss of air to the actuator?

- | | <u>Valve Type</u> | <u>Fail Position</u> |
|----|-------------------|----------------------|
| A. | Gate | Open |
| B. | Gate | Closed |
| C. | Globe | Open |
| D. | Globe | Closed |

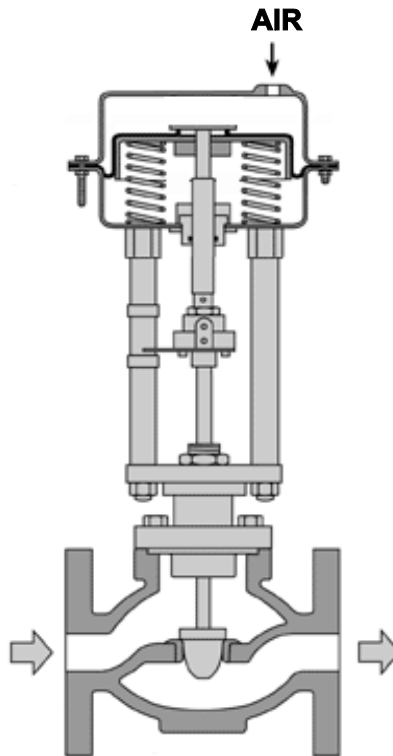

**USNRC GENERIC FUNDAMENTALS EXAMINATION
DECEMBER 2006 PWR--FORM A**

QUESTION: 3

The downcomer region of a steam generator contains 40 feet of saturated water at 536°F. A steam generator water level detector has a pressure tap located at the bottom of the downcomer region. Approximately how much of the total pressure at the pressure tap is caused by the downcomer water?

- A. 0.6 psi
- B. 13.0 psi
- C. 27.7 psi
- D. 156.0 psi

**USNRC GENERIC FUNDAMENTALS EXAMINATION
DECEMBER 2006 PWR--FORM A**

QUESTION: 4

Refer to the drawing of a tank differential pressure (D/P) level detector (see figure below).

The associated level instrument was calibrated with the water in the tank at 120°F. If the mass of water in the tank remains constant and the water temperature decreases to 100°F, the indicated level will...

- A. remain the same although actual level increases.
- B. remain the same although actual level decreases.
- C. increase in direct proportion to the temperature decrease.
- D. decrease in direct proportion to the temperature decrease.

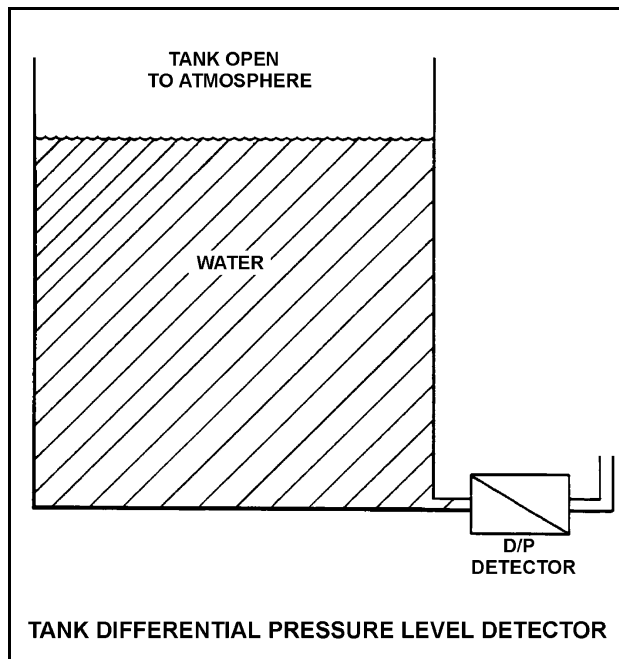

**USNRC GENERIC FUNDAMENTALS EXAMINATION
DECEMBER 2006 PWR--FORM A**

QUESTION: 5

In contrast to a thermocouple, a resistance temperature detector...

- A. is used in high temperature applications.
- B. does not require an external power supply for temperature indication.
- C. uses a single type of metal or alloy in the sensing element.
- D. is commonly placed in direct contact with the monitored substance.

QUESTION: 6

Which one of the following types of radiation is the major contributor to the dose indication on a self-reading pocket dosimeter (SRPD)? (also called SRD, PIC, and direct reading dosimeter)

- A. Alpha
- B. Beta
- C. Gamma
- D. Neutron

**USNRC GENERIC FUNDAMENTALS EXAMINATION
DECEMBER 2006 PWR--FORM A**

QUESTION: 7

An emergency diesel generator (D/G) is operating as the only power source connected to an emergency bus. The governor of the D/G is directly sensing D/G _____ and will directly adjust D/G _____ flow to maintain a relatively constant D/G frequency.

- A. speed; fuel
- B. speed; air
- C. load; fuel
- D. load; air

**USNRC GENERIC FUNDAMENTALS EXAMINATION
DECEMBER 2006 PWR--FORM A**

QUESTION: 8

Refer to the drawing of a lube oil temperature control system (see figure below).

Which one of the following describes the type of control used in the lube oil temperature control system?

- A. Open loop, because lube oil temperature feedback is being provided to the controller from the lube oil temperature transmitter.
- B. Open loop, because lube oil temperature is being controlled by positioning a flow control valve in a separate system.
- C. Closed loop, because lube oil temperature feedback is being provided to the controller from the lube oil temperature transmitter.
- D. Closed loop, because lube oil temperature is being controlled by positioning a flow control valve in a separate system.

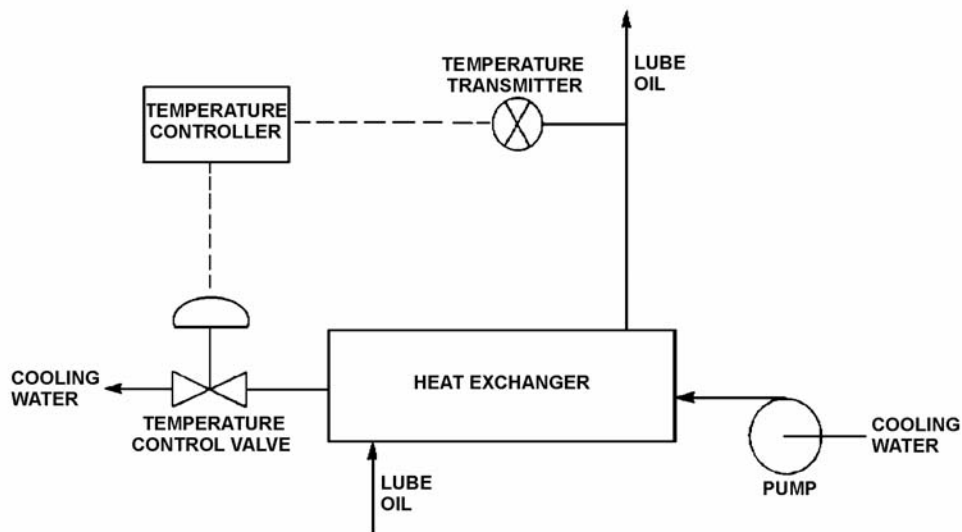

**USNRC GENERIC FUNDAMENTALS EXAMINATION
DECEMBER 2006 PWR--FORM A**

QUESTION: 9

Refer to the valve controller logic diagram (see figure below).

Which one of the following combinations of inputs will result in the valve receiving a close signal?

	INPUTS			
	1.	2.	3.	4.
A.	On	On	Off	Off
B.	Off	Off	On	Off
C.	On	Off	Off	On
D.	On	On	On	Off

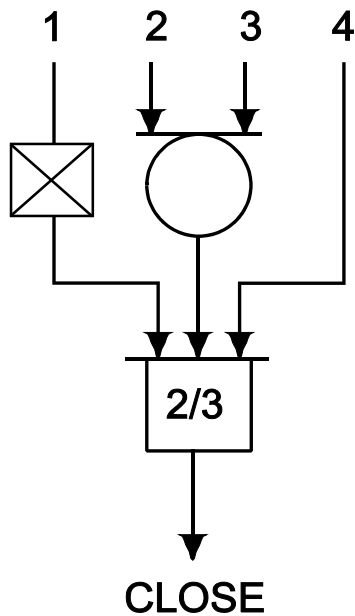

**USNRC GENERIC FUNDAMENTALS EXAMINATION
DECEMBER 2006 PWR--FORM A**

QUESTION: 10

A centrifugal pump is circulating water at 180°F with a pump motor current of 200 amps. After several hours, system temperature has changed such that the water density has increased by 6%.

Assuming pump head and volumetric flow rate do not change, which one of the following is the new pump motor current?

- A. 203 amps
- B. 206 amps
- C. 212 amps
- D. 224 amps

QUESTION: 11

A motor-driven centrifugal pump is operating in an open system with its discharge valve throttled to 50% open. If the discharge valve is fully opened, available net positive suction head (NPSH) will _____ and required NPSH will _____.

- A. remain the same; increase
- B. remain the same; remain the same
- C. decrease; increase
- D. decrease; remain the same

**USNRC GENERIC FUNDAMENTALS EXAMINATION
DECEMBER 2006 PWR--FORM A**

QUESTION: 12

Use the following drawing of system and pump operating curves for a positive displacement pump with discharge relief valve protection to answer the following question.

A positive displacement pump is initially supplying 40 gpm to a system at a pump discharge pressure of 400 psia. Then, pump speed is increased until pump flow rate is 80 gpm. What is the pump discharge pressure at the new pump flow rate of 80 gpm?

- A. 800 psia
- B. 1,000 psia
- C. 1,200 psia
- D. 1,600 psia

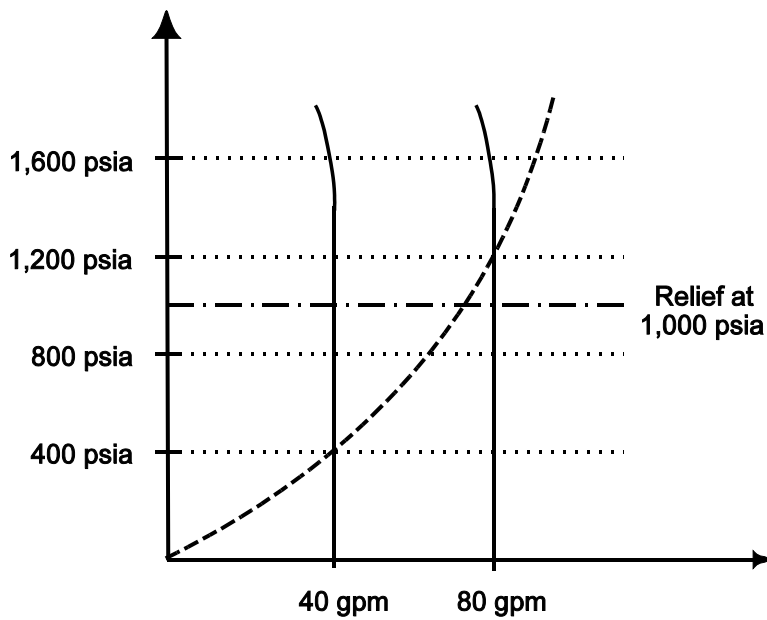

**USNRC GENERIC FUNDAMENTALS EXAMINATION
DECEMBER 2006 PWR--FORM A**

QUESTION: 13

What is the purpose of the safety/relief valve located between the pump outlet and the discharge isolation valve of most positive displacement pumps?

- A. Protect the pump and suction piping from overpressure if the discharge valve is open during system startup.
- B. Protect the pump and suction piping from overpressure if the suction valve is closed during pump operation.
- C. Protect the pump and discharge piping from overpressure if the discharge valve is closed during pump operation.
- D. Protect the pump and discharge piping from overpressure due to thermal expansion of pump contents when the pump is shutdown with its suction valve closed.

**USNRC GENERIC FUNDAMENTALS EXAMINATION
DECEMBER 2006 PWR--FORM A**

QUESTION: 14

A main generator is connected to an infinite power grid with the following initial generator parameters:

Voltage:	22 KV
Frequency:	60 Hertz
Load--Real:	600 MW
Load--Reactive:	100 MVAR (VARS out)
Power Factor:	0.986

Which one of the following contains a combination of manual adjustments to the main generator voltage regulator and speed control setpoints such that each adjustment will initially result in an increase in main generator amps? (Assume the generator power factor remains less than 1.0.)

- | | <u>Voltage
Setpoint</u> | <u>Speed
Setpoint</u> |
|----|-----------------------------|---------------------------|
| A. | Increase | Increase |
| B. | Increase | Decrease |
| C. | Decrease | Increase |
| D. | Decrease | Decrease |

**USNRC GENERIC FUNDAMENTALS EXAMINATION
DECEMBER 2006 PWR--FORM A**

QUESTION: 15

An ac motor-driven centrifugal pump is operating with a flow rate of 3,000 gpm and a motor current of 150 amps. If the pump speed is reduced such that the flow rate is 2,000 gpm, what is the approximate final motor current at the new lower speed? (Assume a constant motor voltage.)

- A. 44 amperes
- B. 59 amperes
- C. 67 amperes
- D. 100 amperes

QUESTION: 16

Steam has been admitted to a main condenser for 25 minutes with no cooling water. Initiating full cooling water flow rate at this time will...

- A. reduce the stress on the condenser shell by rapidly cooling the shell.
- B. reduce the stress on the condenser tubes by rapidly cooling the tubes.
- C. induce large thermal stresses on the condenser shell.
- D. induce large thermal stresses on the junctions between the condenser tubes and the tubesheet.

**USNRC GENERIC FUNDAMENTALS EXAMINATION
DECEMBER 2006 PWR--FORM A**

QUESTION: 17

Refer to the drawing of an operating lube oil heat exchanger (see figure below).

If deposits accumulate on the outside of the cooling water tubes, cooling water outlet temperature will _____ and oil outlet temperature will _____. (Assume oil and cooling water inlet temperatures and flow rates remain the same.)

- A. increase; decrease
- B. increase; increase
- C. decrease; decrease
- D. decrease; increase

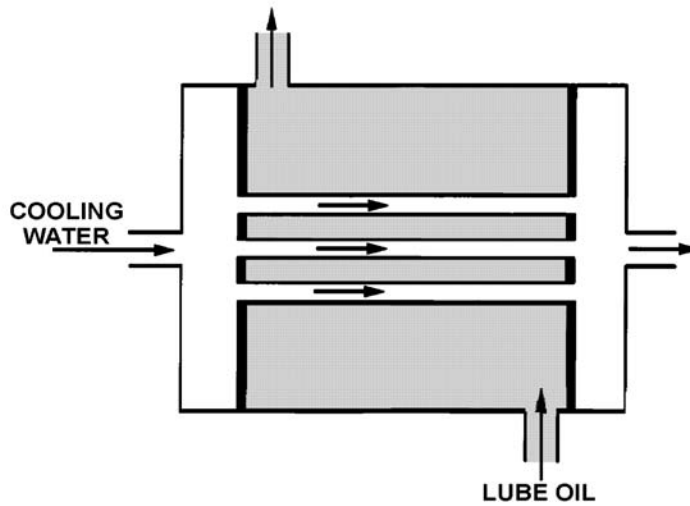

**USNRC GENERIC FUNDAMENTALS EXAMINATION
DECEMBER 2006 PWR--FORM A**

QUESTION: 18

High differential pressure in a demineralizer could be caused by all of the following except...

- A. resin exhaustion.
- B. resin overheating.
- C. crud buildup.
- D. high flow rate.

QUESTION: 19

The decontamination factor (also called the demineralization factor) of a condensate demineralizer has just been determined to be 50, based on conductivity measurements.

If condensate having a conductivity of 20 $\mu\text{mho/cm}$ is flowing into this demineralizer, which one of the following is the conductivity of the condensate at the outlet of the demineralizer?

- A. 0.4 $\mu\text{mho/cm}$
- B. 1.0 $\mu\text{mho/cm}$
- C. 4.0 $\mu\text{mho/cm}$
- D. 10.0 $\mu\text{mho/cm}$

**USNRC GENERIC FUNDAMENTALS EXAMINATION
DECEMBER 2006 PWR--FORM A**

QUESTION: 20

Which one of the following describes the local overcurrent trip flag indicators for a breaker?

- A. They actuate prior to breaker tripping to warn of imminent protective action.
- B. When actuated, they indicate that the breaker overcurrent trip relay has been reset.
- C. They indicate breaker overcurrent trip actuation during and after breaker trip actuation.
- D. When actuated, they indicate that the associated breaker has failed to trip open.

**USNRC GENERIC FUNDAMENTALS EXAMINATION
DECEMBER 2006 PWR--FORM A**

QUESTION: 21

Refer to the drawing of a valve motor control circuit (see figure below) for a valve that is currently fully open and has a 10-second stroke time. Limit switch LS2 has failed open.

Note: Limit switch (LS) contacts are shown open regardless of valve position, but relay contacts follow the standard convention for control circuit drawings.

Which one of the following describes the valve response if the control switch is taken to the “Close” position for 2 seconds and then released?

- A. The valve will not move.
- B. The valve will close fully.
- C. The valve will begin to close and then stop moving.
- D. The valve will begin to close and then open fully.

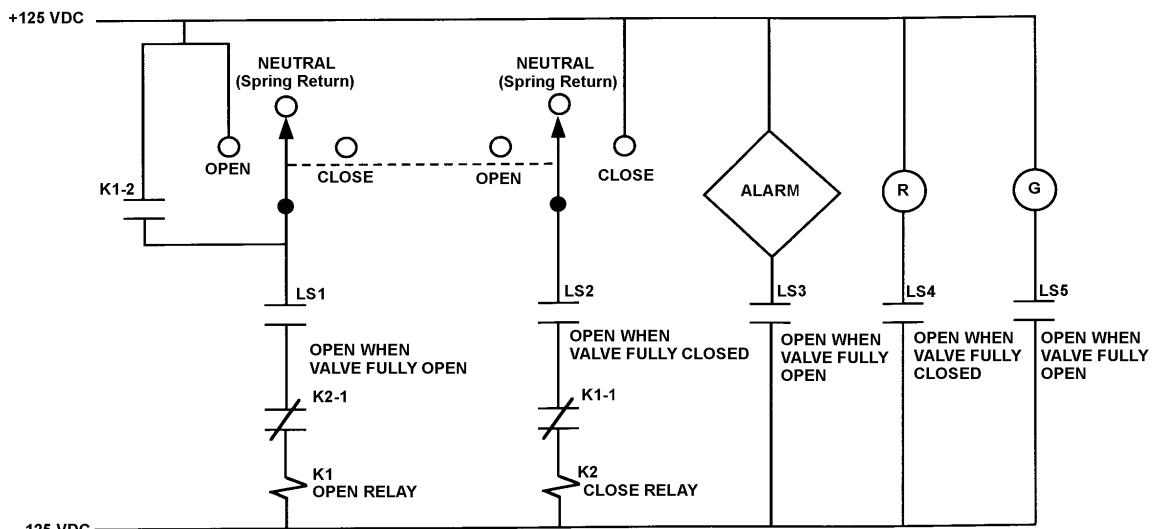

VALVE MOTOR CONTROL CIRCUIT

**USNRC GENERIC FUNDAMENTALS EXAMINATION
DECEMBER 2006 PWR--FORM A**

QUESTION: 22

While remotely investigating the condition of a typical normally-open motor control center (MCC) feeder breaker, an operator observes the following indications:

Green breaker position indicating light is lit.
Red breaker position indicating light is out.
MCC voltmeter indicates zero volts.
MCC ammeter indicates zero amperes.

Based on these indications, the operator can accurately report that the breaker is open and racked to _____ position.

- A. the OUT
- B. the IN
- C. the TEST
- D. an unknown

**USNRC GENERIC FUNDAMENTALS EXAMINATION
DECEMBER 2006 PWR--FORM A**

QUESTION: 23

In a comparison between a delayed neutron and a prompt neutron born from the same fission event, the delayed neutron is more likely to... (Assume that each neutron remains in the core unless otherwise stated.)

- A. cause fission of a U-238 nucleus.
- B. travel to an adjacent fuel assembly.
- C. be absorbed in a B-10 nucleus.
- D. leak out of the core.

QUESTION: 24

Nuclear reactors A and B are identical except that reactor A is operating at steady-state 80% power while reactor B is operating at steady-state 100% power. Initial control rod positions are the same for each reactor.

How will the shutdown margins (SDM) compare for the two reactors following a reactor scram? (Assume no post-scram operator actions are taken that would affect SDM.)

- A. Reactor A will have the greater SDM.
- B. Reactor B will have the greater SDM.
- C. When sufficient time has passed to allow both cores to become xenon-free, the SDMs will be equal.
- D. Within a few minutes after the scrams, when all parameters have returned to normal post-scram conditions, the SDMs will be equal.

**USNRC GENERIC FUNDAMENTALS EXAMINATION
DECEMBER 2006 PWR--FORM A**

QUESTION: 25

A nuclear power plant is initially shutdown with an effective multiplication factor (K_{eff}) of 0.92 and a stable source range count rate of 200 cps. Then, a reactor startup is initiated. All control rod motion is stopped when K_{eff} equals 0.995. The instant that rod motion stops, source range count rate is 600 cps.

When source range count rate stabilizes, count rate will be approximately...

- A. 600 cps.
- B. 650 cps.
- C. 1,800 cps.
- D. 3,200 cps.

QUESTION: 26

A nuclear power plant is initially operating at 50% power. Which one of the following contains only parameters that, if varied, will each directly change the magnitude of the power defect?

- A. Control rod position, reactor power, and moderator voids
- B. Moderator voids, fuel temperature, and moderator temperature
- C. Fuel temperature, xenon concentration, and control rod position
- D. Moderator temperature, reactor coolant pressure, and xenon concentration

**USNRC GENERIC FUNDAMENTALS EXAMINATION
DECEMBER 2006 PWR--FORM A**

QUESTION: 27

A nuclear power plant is operating at steady-state 100% power. Given the following initial parameters, select the final reactor coolant boron concentration required to decrease average coolant temperature by 6°F. (Assume no change in control rod position or reactor/turbine power.)

Initial boron concentration	= 500 ppm
Moderator temperature coefficient	= -0.012% $\Delta K/K$ per °F
Differential boron worth	= -0.008% $\Delta K/K$ per ppm
Inverse boron worth	= -125 ppm/% $\Delta K/K$

- A. 509 ppm
- B. 504 ppm
- C. 496 ppm
- D. 491 ppm

QUESTION: 28

A nuclear reactor is operating at 80% power near the end of a fuel cycle with the controlling group of control rods inserted 5% into the core. Which one of the following will cause group differential rod worth to become less negative? (Consider only the direct effect of the indicated change.)

- A. Burnable poison rods become increasingly depleted.
- B. Core Xe-135 concentration decreases toward an equilibrium value.
- C. Reactor coolant temperature is allowed to decrease from 575°F to 570°F.
- D. Reactor power is decreased to 70% using control rods for control of RCS temperature.

**USNRC GENERIC FUNDAMENTALS EXAMINATION
DECEMBER 2006 PWR--FORM A**

QUESTION: 29

A nuclear reactor is operating at 75% power with all control rods fully withdrawn. Assuming reactor power does not change, which one of the following compares the effects of dropping (full insertion) a single center control rod to the effects of partially inserting (50%) the same control rod?

- A. A dropped rod causes a smaller change in axial power distribution.
- B. A dropped rod causes a smaller change in radial power distribution.
- C. A dropped rod causes a smaller change in shutdown margin.
- D. A dropped rod causes a greater change in shutdown margin.

QUESTION: 30

A nuclear reactor has been operating at 75% power for two months. A manual reactor trip is required for a test. The trip will be followed immediately by a reactor startup with criticality scheduled to occur 12 hours after the trip.

The greatest assurance that fission product poison reactivity will permit criticality during the startup will be attained if the reactor is operated at _____ power for 48 hours prior to the trip and if criticality is rescheduled for _____ hours after the trip.

- A. 100%; 8
- B. 100%; 16
- C. 50%; 8
- D. 50%; 16

**USNRC GENERIC FUNDAMENTALS EXAMINATION
DECEMBER 2006 PWR--FORM A**

QUESTION: 31

A nuclear reactor has been operating at 100% power for two months when a reactor trip occurs. Four hours later, the reactor is critical and stable at 10% power.

Which one of the following operator actions is required to maintain reactor power at 10% over the next 18 hours?

- A. Add positive reactivity during the entire period
- B. Add negative reactivity during the entire period
- C. Add positive reactivity, then negative reactivity
- D. Add negative reactivity, then positive reactivity

QUESTION: 32

Which one of the following is not a function performed by burnable poisons in an operating nuclear reactor?

- A. Provide neutron flux shaping.
- B. Provide more uniform power density.
- C. Offset the effects of control rod burnout.
- D. Allow higher fuel enrichment of initial core load.

**USNRC GENERIC FUNDAMENTALS EXAMINATION
DECEMBER 2006 PWR--FORM A**

QUESTION: 33

Which one of the following indicates that a nuclear reactor has achieved criticality during a normal reactor startup?

- A. Constant positive startup rate during rod withdrawal.
- B. Increasing positive startup rate during rod withdrawal.
- C. Constant positive startup rate with no rod motion.
- D. Increasing positive startup rate with no rod motion.

QUESTION: 34

A multi-loop nuclear power plant is operating at 50% power with manual rod control when the main steam isolation valve (MSIV) for one steam generator inadvertently closes. Assume that no reactor trip or other protective action occurs, and no operator action is taken.

Immediately after the MSIV closure, the cold leg temperature (T_c) in the reactor coolant loop with the closed MSIV will _____; and the T_c in a loop with an open MSIV will immediately _____.

- A. increase; increase
- B. increase; decrease
- C. decrease; increase
- D. decrease; decrease

**USNRC GENERIC FUNDAMENTALS EXAMINATION
DECEMBER 2006 PWR--FORM A**

QUESTION: 35

A nuclear reactor is exactly critical just below the point of adding heat when a single control rod drops into the core. Assuming no operator or automatic actions occur, when the plant stabilizes, reactor power will be _____ and average reactor coolant temperature will be _____.

- A. the same; the same
- B. the same; lower
- C. lower; the same
- D. lower; lower

QUESTION: 36

After one month of operation at 100% reactor power, the fraction of thermal power being produced from the decay of fission products in the operating nuclear reactor is...

- A. greater than 10%.
- B. greater than 5% but less than 10%.
- C. greater than 1% but less than 5%.
- D. less than 1%.

**USNRC GENERIC FUNDAMENTALS EXAMINATION
DECEMBER 2006 PWR--FORM A**

QUESTION: 37

Refer to the drawing of four identical tank differential pressure (D/P) level detectors (see figure below).

The tanks are identical and are presently at 2 psig overpressure, the same constant water level, and a temperature of 60°F. They are surrounded by atmospheric pressure. All level detectors have been calibrated and are producing the same level indication. A leak in the top of each tank causes a complete loss of overpressure in both tanks.

Which level detector(s) will produce the lowest level indication?

- A. No. 1 only
- B. No. 2 only
- C. No. 1 and 4
- D. No. 2 and 3

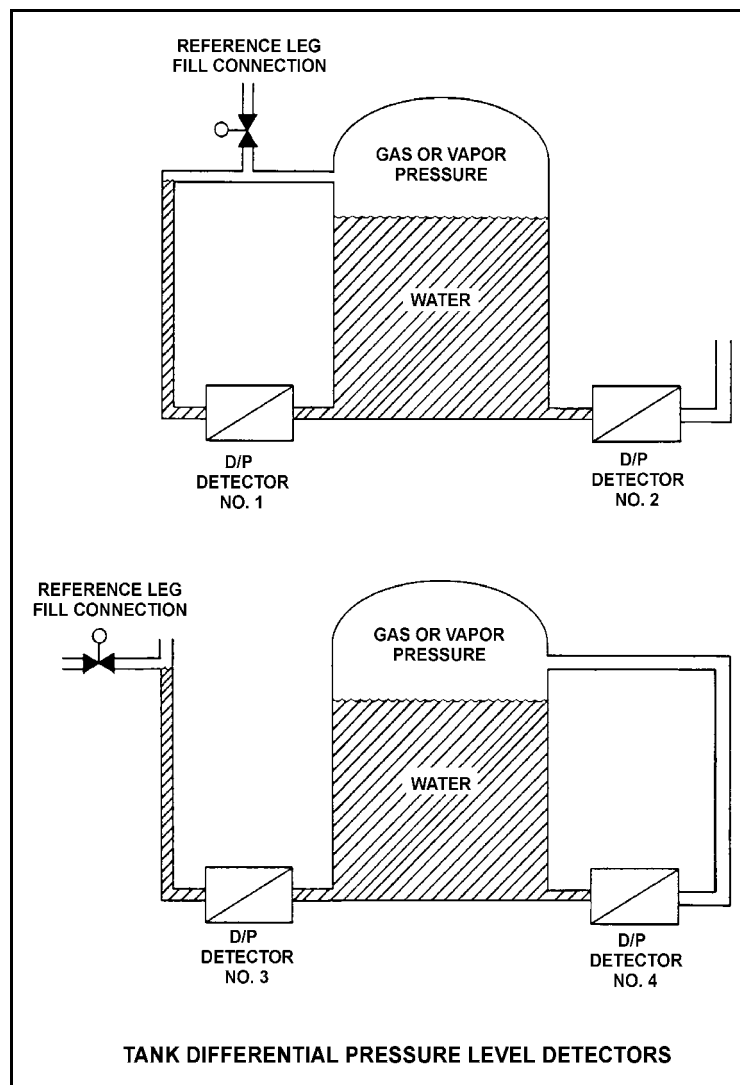

**USNRC GENERIC FUNDAMENTALS EXAMINATION
DECEMBER 2006 PWR--FORM A**

QUESTION: 38

Consider a pressurizer containing a saturated water/steam mixture at 636°F with a quality of 50%. If an outsurge removes 10% of the liquid volume from the pressurizer, the temperature of the mixture will _____ and the quality of the mixture will _____. (Assume the mixture remains saturated.)

- A. decrease; decrease
- B. decrease; increase
- C. remain the same; decrease
- D. remain the same; increase

QUESTION: 39

An open vessel contains one pound-mass of water at 206°F and standard atmospheric pressure. Which one of the following will be caused by the addition of 12.0 Btu to the water?

- A. The water temperature will rise by about 6°F and none of the water will vaporize.
- B. The water temperature will rise by about 6°F and some of the water will vaporize.
- C. The water temperature will rise by about 12°F and none of the water will vaporize.
- D. The water temperature will rise by about 12°F and some of the water will vaporize.

**USNRC GENERIC FUNDAMENTALS EXAMINATION
DECEMBER 2006 PWR--FORM A**

QUESTION: 40

What is the approximate value of condensate depression in a condenser operating at 27 inches Hg vacuum with a condensate temperature of 100°F?

- A. 2°F
- B. 4°F
- C. 8°F
- D. 16°F

QUESTION: 41

Steam turbines X and Y are identical 100% efficient turbines that exhaust to a condenser at 1.0 psia. Saturated steam at 250 psia enters turbine X. Superheated steam at 250 psia and 500°F enters turbine Y.

Which one of the following lists the percentage of moisture at the exhaust of turbines X and Y?

	<u>Turbine X</u>	<u>Turbine Y</u>
A.	24.5%	20.5%
B.	26.3%	13.0%
C.	24.5%	13.0%
D.	26.3%	20.5%

**USNRC GENERIC FUNDAMENTALS EXAMINATION
DECEMBER 2006 PWR--FORM A**

QUESTION: 42

Which one of the following describes the relationship between the main steam mass flow rate leaving a steam generator and the main feedwater mass flow rate entering the same steam generator at steady-state power operation? (Assume no other addition/removal of steam generator inventory.)

- A. The mass flow rates will be the same only if downcomer level is constant.
- B. The mass flow rates will be the same only if the reactor is operating near rated power.
- C. The main steam mass flow rate is smaller than the main feedwater mass flow rate by the amount of moisture removed by the steam generator moisture separators.
- D. The main steam mass flow rate is greater than the main feedwater mass flow rate by the amount of moisture removed by the steam generator moisture separators.

QUESTION: 43

A centrifugal water pump is being returned to service after maintenance. However, the operator fails to vent the pump.

Compared to normal operations, after the pump is started, the operator will see _____ flow rate and _____ discharge head.

- A. higher; lower
- B. higher; higher
- C. lower; lower
- D. lower; higher

**USNRC GENERIC FUNDAMENTALS EXAMINATION
DECEMBER 2006 PWR--FORM A**

QUESTION: 44

Two of the parameters listed below are used for calculating core thermal power using the standard heat balance method. Which one of the following identifies the two parameters?

	<u>Reactor Coolant Mass Flow Rate</u>	<u>Feedwater Temperature</u>	<u>Steam Generator Pressure</u>	<u>Steam Generator Water Level</u>
A.	Yes	No	Yes	No
B.	No	Yes	Yes	No
C.	Yes	No	No	Yes
D.	No	Yes	No	Yes

QUESTION: 45

Which one of the following describes the conditions in a fuel coolant channel that is experiencing transition boiling?

- A. Complete steam blanketing of the fuel rod surface
- B. Alternate wetting and drying of the fuel rod surface
- C. Saturated nucleate boiling
- D. Subcooled nucleate boiling

**USNRC GENERIC FUNDAMENTALS EXAMINATION
DECEMBER 2006 PWR--FORM A**

QUESTION: 46

If a nuclear reactor is operating with DNBR at its limit, which one of the following is indicated?

- A. None of the fuel rods are experiencing critical heat flux.
- B. A small fraction of the fuel rods may be experiencing critical heat flux.
- C. All radioactive fission products are being contained within the reactor fuel.
- D. All radioactive fission products are being contained within either the reactor fuel or the reactor vessel.

QUESTION: 47

Which one of the following is most likely to result in steam bubble formation in a reactor vessel head while maintaining a 40°F subcooling margin in the hottest RCS hot leg?

- A. Performing a 25°F/Hr RCS cooldown on natural circulation.
- B. Performing a 25°F/Hr RCS cooldown on forced circulation.
- C. Performing a 50°F/Hr RCS cooldown on natural circulation.
- D. Performing a 50°F/Hr RCS cooldown on forced circulation.

**USNRC GENERIC FUNDAMENTALS EXAMINATION
DECEMBER 2006 PWR--FORM A**

QUESTION: 48

A reactor coolant system natural circulation cooldown is in progress via the steam generator (S/G) atmospheric steam relief valves (operated in manual control).

If voids interrupt natural circulation, which one of the following will occur? (Assume feed flow rate, relief valve position, and decay heat level are constant.)

- A. S/G pressure decreases and core exit thermocouple (CETC) temperature increases.
- B. S/G pressure decreases and CETC temperature remains constant.
- C. S/G pressure increases and CETC temperature increases.
- D. S/G pressure increases and CETC temperature remains constant.

QUESTION: 49

A PWR core consists of 50,000 fuel rods; each fuel rod has an active length of 12 feet. The core is producing 1,800 MW of thermal energy. If the nuclear heat flux hot channel factor, $F_Q(z)$, (also called the total core peaking factor) is 2.0, what is the maximum local linear power density being produced in the core?

- A. 4.5 kW/ft
- B. 6.0 kW/ft
- C. 9.0 kW/ft
- D. 12.0 kW/ft

**USNRC GENERIC FUNDAMENTALS EXAMINATION
DECEMBER 2006 PWR--FORM A**

QUESTION: 50

Which one of the following comparisons increases the probability of brittle fracture of a pressure vessel wall?

- A. A high temperature rather than a low temperature.
- B. A tensile stress rather than a compressive stress.
- C. Performing a 100°F/hour heatup rather than a 100°F/hour cooldown.
- D. Using materials fabricated from stainless steel rather than carbon steel.

***** FINAL ANSWER KEY *****

**DECEMBER 2006 NRC GENERIC FUNDAMENTALS EXAMINATION
PRESSURIZED WATER REACTOR - ANSWER KEY**

<u>FORM A</u>	<u>FORM B</u>	<u>ANS.</u>	<u>FORM A</u>	<u>FORM B</u>	<u>ANS.</u>
1	15	B	26	40	B
2	16	C	27	41	A
3	17	B	28	42	C
4	18	B	29	43	A
5	19	C	30	44	D
6	20	C	31	45	C
7	21	A	32	46	C
8	22	C	33	47	C
9	23	B	34	48	B
10	24	C	35	49	C
11	25	C	36	50	B
12	26	B	37	1	D
13	27	C	38	2	B
14	28	A	39	3	B
15	29	A	40	4	D
16	30	D	41	5	A
17	31	D	42	6	A
18	32	A	43	7	C
19	33	A	44	8	B
20	34	C	45	9	B
21	35	A	46	10	B
22	36	D	47	11	C
23	37	C	48	12	A
24	38	A	49	13	B
25	39	D	50	14	B