

From: "DeWald, Lynn" <ldewald@entergy.com>
To: <rle@nrc.gov>, <david.s.miller@anl.gov>
Date: 10/03/2006 12:14:34 PM
Subject: Cooling Tower Report for VY

Attached is the VY Evaporative Loss Report, Revision 1, with twenty-one (21) 200 HP fans and one (1) 125 HP fan. This is the final as-installed configuration. The report discusses drift and evaporative loss. Lynn

CC: "BUCKLEY, RICKY N" <RBUCKLE@entergy.com>

Mail Envelope Properties (45228C62.AFC : 7 : 43772)

Subject: Cooling Tower Report for VY
Creation Date 10/03/2006 12:13:22 PM
From: "DeWald, Lynn" <ldewald@entergy.com>

Created By: ldewald@entergy.com

Recipients

nrc.gov
 OWGWPO02.HQGWDO01
 RLE (Richard Emch)

entergy.com
 RBUCKLE CC (RICKY N BUCKLEY)

anl.gov
 david.s.miller

Post Office
 OWGWPO02.HQGWDO01

Route
 nrc.gov
 entergy.com
 anl.gov

Files	Size	Date & Time
MESSAGE	218	10/03/2006 12:13:22 PM
TEXT.htm	2012	
VY CT Evap R1 2003-06-11.pdf		374435
Mime.822	517436	

Options

Expiration Date: None
Priority: Standard
ReplyRequested: No
Return Notification: None

Concealed Subject: No
Security: Standard

Junk Mail Handling Evaluation Results

Message is eligible for Junk Mail handling
 This message was not classified as Junk Mail

Junk Mail settings when this message was delivered

Junk Mail handling disabled by User
Junk Mail handling disabled by Administrator
Junk List is not enabled
Junk Mail using personal address books is not enabled
Block List is not enabled



**EXTENDED POWER UPRATE
COOLING TOWER EVAPORATIVE LOSS STUDY
for
VERMONT YANKEE NUCLEAR POWER STATION**

Prepared for
Entergy Nuclear Vermont Yankee, LLC

Revision 1
June 2003

Prepared by





Shaw[™] Stone & Webster, Inc.

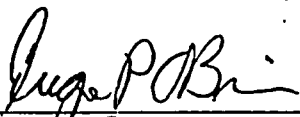

**EXTENDED POWER UPRATE
COOLING TOWER EVAPORATIVE LOSS STUDY
for
VERMONT YANKEE NUCLEAR POWER STATION**

Prepared for
Entergy Nuclear Vermont Yankee, LLC

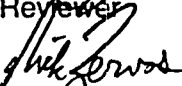
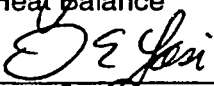
Revision 1
June 2003

 Preparer	11 JUNE 2003 Date
 Reviewer	6/11/03 Date
 Heat Balance	6/11/03 Date
 Project Lead	6/11/03 Date
 Project Manager	6/11/03 Date

Prepared by



TABLE OF CONTENTS

1	OBJECTIVE	1
2	SUMMARY OF RESULTS	1
3	EVALUATION	1
3.1	Methodology	1
	Background	1
	Approach	2
3.2	Inputs and Assumptions	3
3.3	Evaluation of Summer Water Consumption Rates	4
3.4	Evaluation of Winter Water Consumption Rates	7
3.5	Minimum River Flow	9
4	CONCLUSION	10
5	REFERENCES	10

APPENDIX A – SUPPLEMENTAL INFORMATION

- Figure A-1 Circulating Water, Condenser, Cooling Tower Network
Figure A-2 Determination of Flow Rates

1 OBJECTIVE

The purpose of this report is to determine the Vermont Yankee Nuclear Power Station (VYNPS) cooling towers' increased water consumption rate due to evaporation and drift under Extended Power Uprate (EPU) conditions of 120% Reactor Thermal Power.

- Safety Classification: Non-Safety Related
- Affected System: Circulating Water (CW)

Revision 1 of this report incorporates new PEPSE heat balance runs, which utilized 125 HP cooling tower fans. The PEPSE results of Table 3.3-3 were revised to bound the original 200 HP cases and new 125 HP cases. PEPSE was only used as a check on the evaluation method, and this revision confirms that there are no changes to the results or conclusions of the original study, assuming 125 HP to 200 HP fans. This revision supercedes the previous version of the report dated February 2003.

2 SUMMARY OF RESULTS

Monthly average water consumption rates determined in this report are summarized on Figures 3.3-1 and 3.3-2 for summer cooling tower operation, Figures 3.4-1 and 3.4-2 for winter cooling tower operation, and Table 3.5-1 for minimum river flow conditions.

In the limiting case of minimum river flow, as given in Table 3.5-1, the evaporation and drift consumption is less than 1.5% of the minimum river flow value of 1250 cfs.

3 EVALUATION

3.1 Methodology

Background

The VYNPS is currently licensed to operate at a core thermal power of 1593 MWt. This study evaluates the change in evaporative loss as a result of increasing the core power rating up to 1912 MWt, an increase of approximately 20%. Evaporative loss is the amount of water vapor evaporated and discharged from the cooling tower fans into the atmosphere. Drift is the water entrained in vapor discharged from the cooling tower. The evaporative loss plus drift represents a use of river water that is not recycled back to the river.

During cold weather / winter periods from October 15 through May 15, the circulating water system is normally operated in straight open cycle. This means that the river water drawn into the plant intake is passed once through the condenser and returned to the river without using the cooling tower. With open cycle, there is no evaporative cooling and therefore no evaporative loss.

During warmer weather / summer periods from May 16 to October 14, the cooling tower operates predominantly in hybrid mode. In hybrid mode, the cooling tower operation, or load on the cooling tower, varies as environmental conditions change consistent with NPDES thermal discharge limits. For example, when the river flow is high (greater than approximately 8000 cfs), the thermal capacity of the river is high and the cooling tower is either not needed, or is very lightly loaded. On the other hand, during extreme summer drought conditions when the river

flow is low and the river temperature is high, the river's thermal capacity is minimal, and the evaporative cooling process of the cooling towers rejects most of the plant's heat load.

The highest evaporation rate occurs when operating in closed cycle where the entire plant's heat load is handled by the cooling towers. At Vermont Yankee, the cooling tower is operated very rarely in closed-cycle mode (about once every 2 or 3 days per week in summer for only 2 hours while chlorination treatments are performed).

Approach

Since the cooling tower operates primarily in hybrid mode, and the cooling tower heat load (and rate of evaporation) can vary widely each day, this evaluation determined monthly average evaporative loss values based on over 11 years of historical monthly average environmental conditions. The evaporation rate was determined for the following operating conditions:

- 100% Power, Current NPDES, Summer
- 120% Power, Current NPDES, Summer
- 120% Power, Proposed NPDES, Summer
- 120% Power, Current NPDES, Winter (only during winter months with <1500 cfs river flow)

Heat transfer by the cooling tower is accomplished mostly by the evaporation of water. A small amount of this heat is also used to increase the sensible heat of air leaving the tower. This study estimated evaporative loss with the conservative assumption that all cooling tower heat transfer was by evaporation, calculated using the Latent Heat of Evaporation (H_{fg}) of water at the cooling tower Inlet.

The monthly average cooling tower heat load was determined from heat balance data. Heat balances were performed using a Performance Evaluation of Power System Efficiencies (PEPSE) model (Ref. 1) of the plant, including the heat rejection system. The cooling tower performance characteristics used in the PEPSE model were based on the predictions in the Tower Performance, Inc (TPI) cooling tower report (Ref. 2).

For PEPSE to calculate the cooling tower heat load, three boundary condition parameters were required (river flow, allowable river temperature rise, and wet bulb temperature). The allowable river temperature rise was determined from the NPDES permit. Table 3.1-1 summarizes the available environmental data.

**Table 3.1-1
Available Environmental Data**

	River Temperature	River Flow	Wet Bulb
1991 thru 1999	12 mos ⁽²⁾	12 mos ⁽²⁾	12 mos ⁽¹⁾
2000 & 2001	12 mos ⁽²⁾	12 mos ⁽²⁾	NA
2002	May – Dec. ⁽²⁾	May - Dec. ⁽²⁾	NA

1. National Climatic Data Center (NCDC) Source - actual data was dew point and drybulb temperatures from which wetbulb temperature was calculated (see Ref. 4).
2. Normandeau Source (see Ref. 3) - Normandeau provided the mean monthly values in lieu of the raw hourly data. Note October 1996 data not available.

This report used a simplified method to calculate the cooling tower heat load that only required river flow data and allowable river temperature rise (not wet bulb temperature) by:

1. Assuming the condenser duty or heat rejection was a constant for each power level. The values chosen were based on bounding PEPSE runs. See Inputs and Assumptions Section 3.2 e.
2. Calculating the river heat capacity based on river flow and allowable temperature differential from NPDES permit.
3. Calculating the cooling tower heat load by subtracting the river heat capacity from the condenser duty.

Using the simplified method, the evaporative loss for 1991 through 2002 period was calculated. More detailed PEPSE model analyses were performed for several cases for comparison purposes. This comparison confirmed that the simplified analyses were conservative.

For winter months that historically have had significant times (greater than 100 hours) of river flow below 1500 cfs, evaporation rates were determined using the average river flow and the current winter NPDES permit limit. As shown in Appendix A, Figure A-2, 1500 cfs is the approximate minimum river flow required to accommodate the 120% heat load with current winter NPDES permit limit. Evaporation rates for such winter periods were estimated using a simplified analysis similar to the summer analysis.

Comparison cases were also evaluated for a minimum river flow of 1250 cfs and the 7Q10 river flow rate of 1524 cfs. 7Q10 is a measure of the naturally recurring low river flow. It is the lowest flow that occurs for 7 consecutive days in a 10-year period.

3.2 Inputs and Assumptions

- a. River Temperature and Flow data was obtained from Mark Mattson, Vice President, Normandeau Associates, Inc. (Ref. 3)
- b. Dew point and drybulb temperature data for Albany was obtained from the National Climatic Data Center (NCDC) (Ref. 4).
- c. The cooling tower performance predictions were obtained from Tower Performance Inc. (TPI). TPI Cooling Tower Report for Vermont Yankee (Ref. 2).
- d. PEPSE current and uprate heat balance models (Ref. 1) were used as input to this analysis. These models are tuned to plant operating data. The uprate model incorporated the proposed new HP steam turbine.
- e. Heat rejection for the 100% case of 3712×10^6 Btu/hr and for the 120% case of 4443×10^6 Btu/hr was based upon 5 in. Hg condenser backpressure. This was conservative, as the condenser will typically operate at a lower backpressure, resulting in less heat rejection (Ref. 1).
- f. This study utilized a 1.6 degree temperature increase in lieu of the current NPDES summer permit of 2 degree temperature increase to reflect current plant operational practice. This was conservative because using a lower increase in river temperature resulted in greater calculated evaporation. Likewise, a 2.6 degree temperature increase was used in lieu of the proposed NPDES summer permit of 3 degree temperature increase, which also resulted in greater calculated evaporation.

- g. The higher NPDES limits allowed during brief periods in the Spring and Fall due to lower river temperatures have been conservatively ignored. These higher limits would result in lower evaporation rates than determined in this study.
- h. Latent heat of evaporation, h_{fg} , of 1031.4 Btu/lb based upon a maximum estimated cooling tower inlet water temperature of 110°F.
- i. Winter study utilized a 13 degree allowable river temperature increase. This is conservatively lower than the 13.4 degree rise contained in the current NPDES winter permit to account for operating margin.
- j. The minimum river flow utilized for a comparison case was 1250 cfs. This flow is for comparison only and not based upon recorded data.
- k. The 7Q10 comparison case utilized a river flow of 1,971,129,600 gpd (1524 cfs) based upon Vermont Water Quality Standards and *Reference 5*.
- l. The cooling tower drift was 183 gpm (total for both towers) based upon 0.05% of the total circulating water flow of 366,000 gpm as described in *Reference 2*. The drift was added to the evaporation to obtain total water consumption. The increase in drift due to higher horsepower cooling tower fan motors was considered to be negligible. The drift was assumed to be 183 gpm for both summer and winter evaluations, even though winter operation may potentially utilize lower Circulating Water flows, which would result in less drift.

3.3 Evaluation of Summer Water Consumption Rates

The simplified approach described in Section 3.1 was utilized to calculate monthly average evaporation rates. Using the average monthly river flow supplied by Normandeau for May through October for the years 1991 through 2002, the cooling tower heat load was determined by subtracting the allowable heat rejection to the river from the condenser duty. The evaporative loss was calculated using the Latent Heat of Evaporation, h_{fg} . Three different cases were evaluated: 100% power with current NPDES permit, 120% power with current NPDES permit, and 120% power with proposed NPDES permit. The calculated evaporation rates are shown on Figures 3.3-1 and 3.3-2 in terms of gpm and as percent of river flow. As stated in Assumption (l), drift of 183 gpm was added to the calculated evaporation to determine total water consumption.

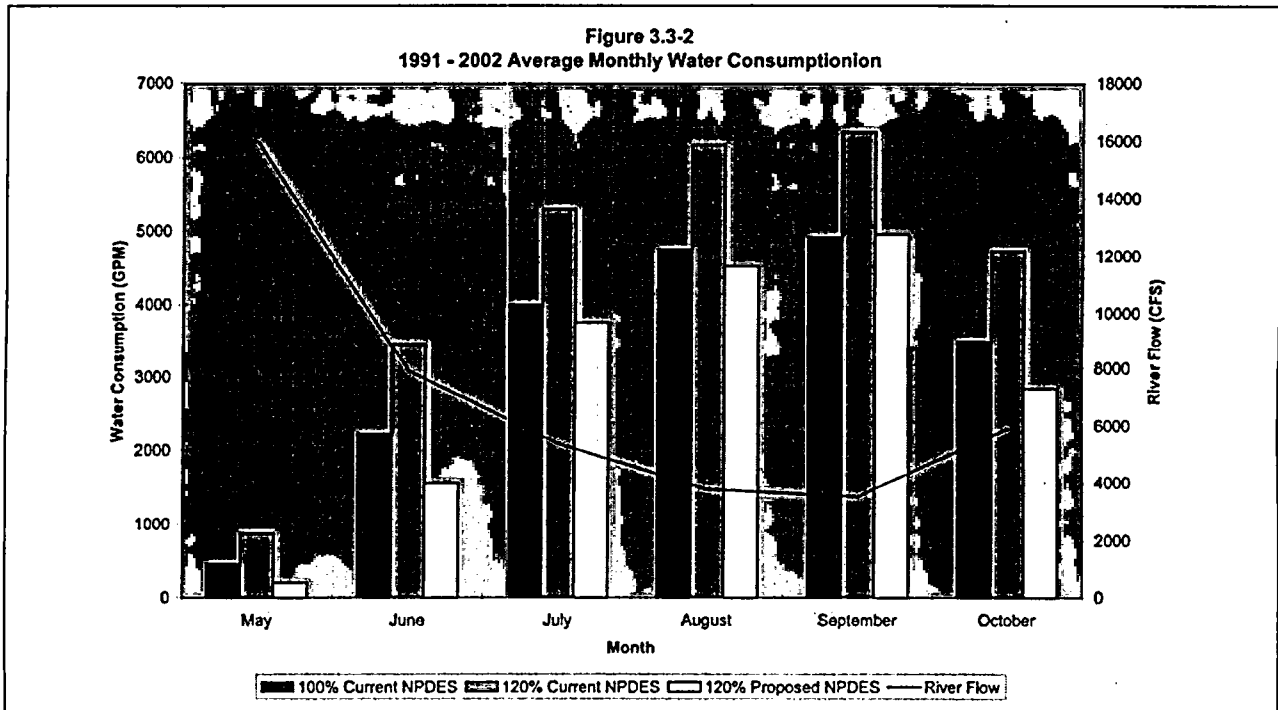
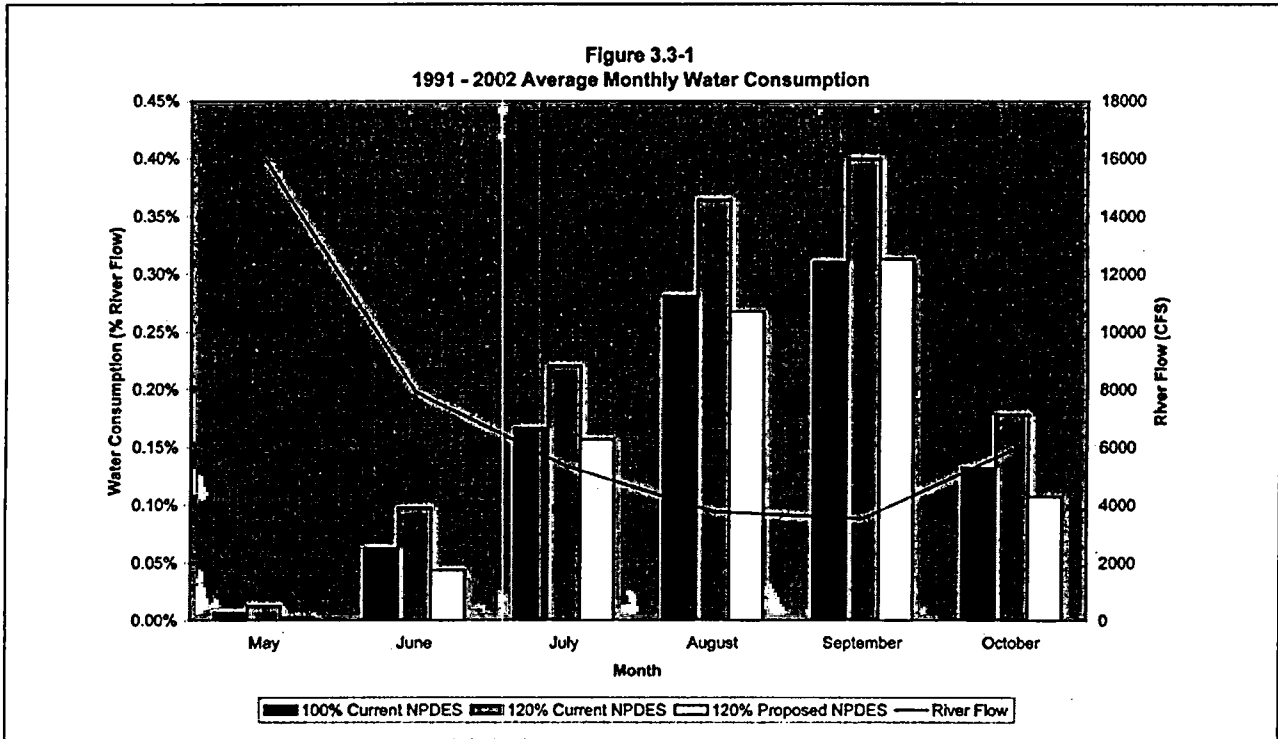

Note the difference in evaporation rates between 120% Current NPDES and 120% Proposed NPDES cases. The proposed 1°F higher river temperature rise reduced the load on the cooling tower, and thereby reduced evaporation. When river flow is above approximately 3800 cfs (see Appendix A, Figure A-2), the 120% case at the proposed NPDES has less evaporation than

both the 120% and 100% cases with the current NPDES limits. Tables 3.3-1 and 3.3-2 give the 1991-2002 Average Monthly Consumption for % river flow and gpm, respectively.

TABLE 3.3-1
1991 - 2002 Average Monthly Water Consumption (% River Flow)

Month	100% Current NPDES	120% Current NPDES	120% Proposed NPDES	River Flow (CFS)
May	0.01%	0.01%	0.00%	15931
June	0.06%	0.10%	0.04%	7922
July	0.17%	0.22%	0.16%	5369
August	0.28%	0.36%	0.27%	3773
September	0.31%	0.40%	0.31%	3536
October	0.13%	0.18%	0.11%	5909

TABLE 3.3-2
1991 - 2002 Average Monthly Water Consumption (gpm)

Month	100% Current NPDES	120% Current NPDES	120% Proposed NPDES	River Flow (CFS)
May	460	878	205	15931
June	2227	3460	1545	7922
July	4000	5300	3759	5369
August	4754	6172	4530	3773
September	4919	6337	4960	3536
October	3503	4733	2841	5909

The tuned PEPSE model incorporated the cooling tower, the river, and the necessary splitters, mixers, and source components to simulate the various modes of CW System operation (Open Cycle, Closed Cycle, and Hybrid Cycle). The PEPSE model was used to spot check the results of the simplified analysis, and it was found that the latter produces reasonably accurate results that slightly overpredict the evaporation rate. Table 3.3-3 presents the comparison of the simplified analysis versus the PEPSE analyses results.

TABLE 3.3-3
Comparison between Simplified (h_{fg}) Method and PEPSE

Month	Mean River Flow (cfs)	Wet Bulb Temp. (°F)	Reactor Thermal	River Temp. (°F)	NPDES (°F)	Evaporation Rate		Difference (%)
						Simplified (h_{fg}) method (gpm)	PEPSE method (gpm)	
Aug-98	5050	64.9	120	73.1	2	4403	4218	4.21
Sep-98	3828	58.6	120	68.7	3	3802	3583	5.76
Jun-99	3212	62	120	70.7	1.6	6561	6465	1.47
Jul-99	3300	66.7	120	76.1	2.6	5065	4926	2.74
Aug-98	5050	64.9	100	73.1	2	2986	2762	7.52
Jun-99	3212	62	100	70.7	1.6	5144	5034	2.13

3.4 Evaluation of Winter Water Consumption Rates

The cooling tower is not presently used in the winter. For power uprate with the current NPDES permit, occasional use of the cooling towers will be required when river flow is low.

The winter evaporation was evaluated for the months of November through March using historical river flow data from the years 1991 through 1995. To be considered, at least 100 hours when the flow was less than 1500 cfs had to be recorded in a given month. Based upon data supplied by Normandeau, nine months over the 1991 – 1995 Winter period met this criterion. The months and the average flow are given in Table 3.4-1.

TABLE 3.4-1
Low River Flow Winter Months

Month / Year	Average River Flow (cfs)
November 1991	1315.48
December 1992	1387.52
February 1993	1411.86
March 1993	1425.96
January 1994	1439.93
February 1994	1443.86
November 1994	1361.37
February 1995	1458.96
December 1995	1355.66

The evaporation for these months was calculated using the simplified method previously described in the Summer evaluation. Based upon 120% heat rejection, river flow, and a 13 degree increase in river temperature, the amount of evaporation was calculated. Per Assumption (I), drift of 183 gpm is added to the evaporation. Monthly averages of data points in Table 3.4-1 were computed and the results are shown on Figures 3.4-1 and 3.4-2 and Tables 3.4-2 and 3.4-3. The evaporation rates shown below are reflective of when the cooling towers are operating in the winter, which is expected to be less than 20% of the winter period.

Figure 3.4-1
 1991 - 1995 Average Winter Water Consumption for Low River Flow

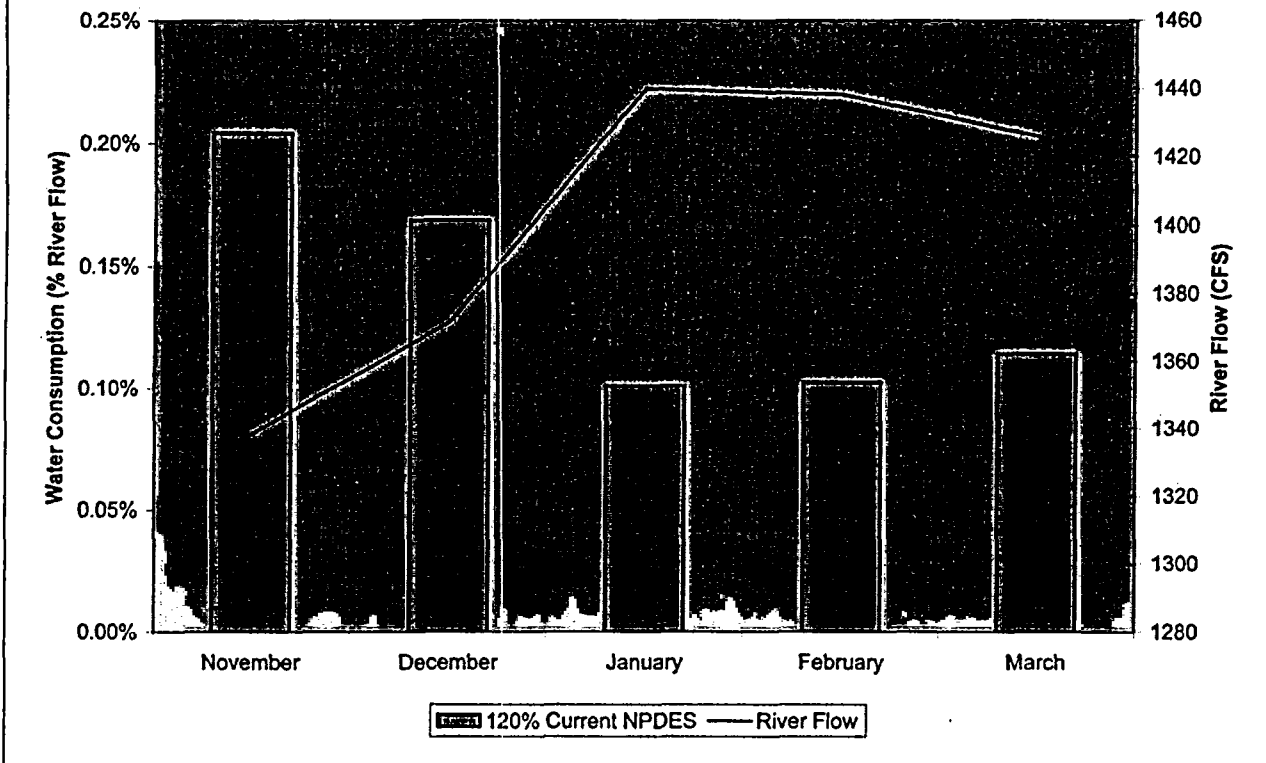

Figure 3.4-2
 1991 - 1995 Average Winter Water Consumption for Low River Flow

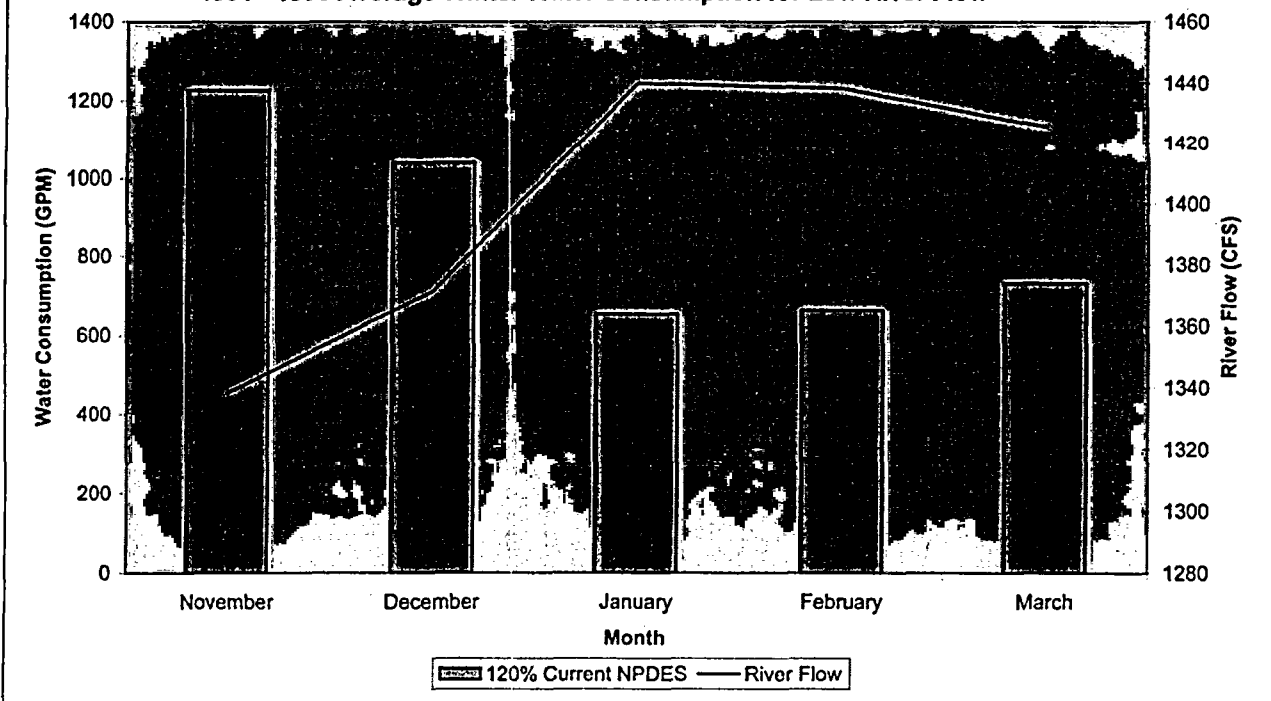

TABLE 3.4-2
1991 - 1995 Average Winter Water Consumption
for Low River Flow (% River Flow)

Month	120% Current NPDES	River Flow (cfs)
November	0.20%	1338
December	0.17%	1372
January	0.10%	1440
February	0.10%	1438
March	0.11%	1426

TABLE 3.4-3
1991 - 1995 Average Winter Water Consumption
for Low River Flow (gpm)

Month	120% Current NPDES	River Flow (cfs)
November	1227	1338
December	1039	1372
January	653	1440
February	662	1438
March	732	1426

3.5 Minimum River Flow

To provide a basis for comparison, the evaporation with the minimum river flow of 1250 cfs and the 7Q10 Indirect Discharge Permit (Reference 5) flow of 1524 cfs was calculated for the 100% power level with the current NPDES permit, 120% power with the current NPDES permit, and 120% power with the proposed NPDES permit. The cooling tower drift of 183 gpm was added to determine total water consumption. The results are shown in Table 3.5-1. The highest monthly average consumption (September) from Tables 3.3-1 and 3.3-2 is repeated in Table 3.5-1 for comparison purposes.

TABLE 3.5-1
Average Water Consumption for Minimum River
and 7Q10 Indirect Discharge Permit Flow

Flow Condition	River Flow (cfs)	Evaporation and Drift Consumption					
		100% Current NPDES		120% Current NPDES		120% Proposed NPDES	
		gpm	% River Flow	gpm	% River Flow	gpm	% River Flow
Minimum River Flow	1250	6511	1.16	7928	1.41	7384	1.32
7Q10 ID Permit Flow	1524	6320	0.92	7738	1.13	7074	1.03
September Monthly Average Flow	3536	4919	0.31	6337	0.40	4960	0.31

4 CONCLUSION

The above evaluation shows that the monthly average evaporation rates and corresponding water consumption rates are small compared to the average river flow. In the limiting case of minimum river flow, as shown in Table 3.5-1, the evaporation and drift consumption is less than 1.5% of the minimum river flow value of 1250 cfs.

5 REFERENCES

1. VYNPS PEPSE Heat Balance Models:

Run101EVL.mdl	2-5-2003
Run102EVL.mdl	2-5-2003
Run103EVL.mdl	2-5-2003
Run104EVL.mdl	2-5-2003
Run105EVL.mdl	2-5-2003
Run106EVL.mdl	2-5-2003
Run107EVL.mdl	6-2-2003
Run108EVL.mdl	6-2-2003
Run109EVL.mdl	6-2-2003
Run110EVL.mdl	6-2-2003
Run111EVL.mdl	6-2-2003
Run112EVL.mdl	6-2-2003

2. Tower Performance, Inc (TPI) Cooling Tower Report, TPI Reference No. TP-10202, "Vermont Yankee Cooling Tower Study", dated December 10, 2002.
3. River flow and temperature data from Normandeau Associates, Excel file "Flow_and_Temp96-02_new".
4. National Climatic Data Center (NCDC) Wet Bulb Temperature for Albany, NY 1990-1999.
5. Entergy Nuclear Vermont Yankee Indirect Discharge Permit, ID-9-0036-1A, June 10, 2002.

Appendix A

Supplemental Information

Figure A-1
Circulating Water, Condenser, Cooling Tower Network

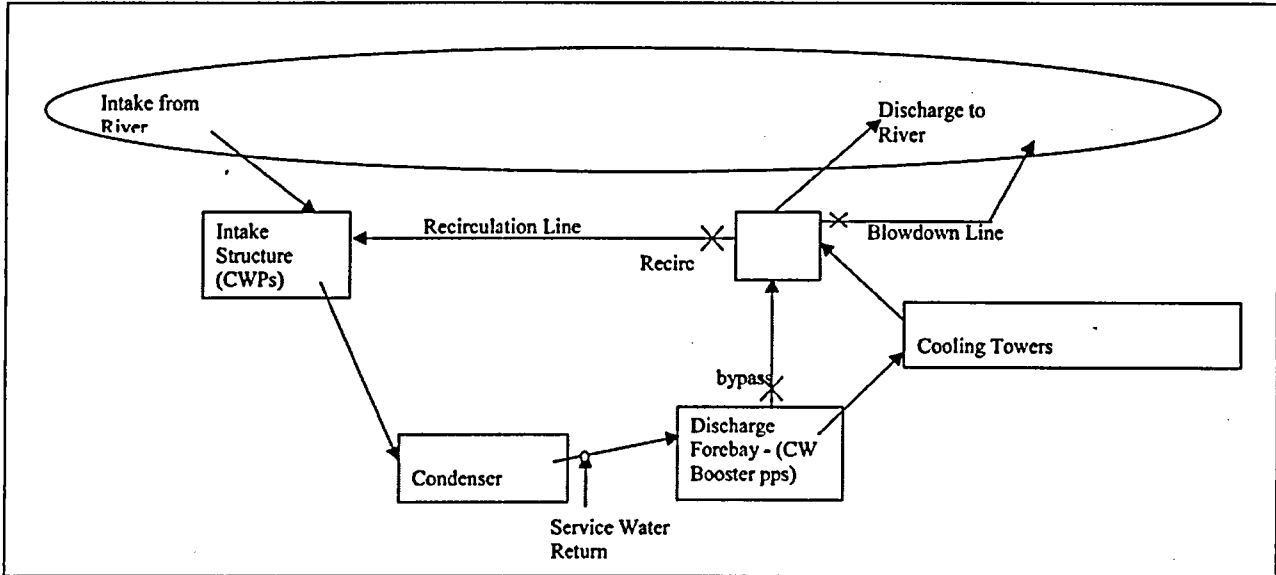

Figure A-2
Determination of Flow Rates

Winter Flow:

The minimum river flow required to accommodate the 120% heat load of 4443×10^6 Btu/hr with the current winter NPDES allowable temperature rise of 13.4°F is calculated using:

$$Q = mC_p\Delta T$$

Where:

$$Q = \text{Heat load} = 4443 \times 10^6 \text{ Btu/hr (Reference 1)}$$

$$m = \text{river mass flow rate (lb}_m\text{/hr)}$$

$$C_p = \text{Specific heat of water} \sim 1.00 \text{ BTU}/(\text{lb}_m \text{ } ^\circ\text{F)}$$

$$\Delta T = 13.4 \text{ } ^\circ\text{F}$$

$$m = Q/(C_p\Delta T)$$

$$m = 4443 \times 10^6 \text{ Btu/hr} / [(1.00 \text{ Btu}/(\text{lb}_m \text{ } ^\circ\text{F}) \times (13.4 \text{ } ^\circ\text{F})]$$

$$m = 3.3157 \times 10^6 \text{ lb}_m\text{/hr}$$

$$m = 3.3157 \times 10^6 \text{ lb}_m\text{/hr} \times (\text{ft}^3/62.4 \text{ lb}_m) \times (\text{hr}/3600 \text{ sec})$$

$$m \sim 1500 \text{ cfs}$$

Summer Flow:

Increasing the current Summer NPDES permit of 2° to 3°F was evaluated to determine the river flow where the heat load on the cooling towers at 120% would be less than the current 100% load. Using the maximum differential heat load rejected from the condenser between the 100% and 120% power levels and a temperature increase of 1°F, the capability of the river to absorb this heat load was evaluated.

$$Q_{120} = 120\% \text{ Heat load at 5 in. Hg condenser pressure} = 4443 \times 10^6 \text{ Btu/hr (Ref. 1)}$$

$$Q_{100} = 100\% \text{ Heat load at 1 in. Hg condenser pressure} = 3584 \times 10^6 \text{ Btu/hr (Ref. 1)}$$

$$Q = Q_{120} - Q_{100} = (4443 \times 10^6) - (3584 \times 10^6) = 859 \times 10^6 \text{ Btu/hr}$$

$$\Delta T = 3^\circ\text{F} - 2^\circ\text{F} = 1^\circ\text{F}$$

$$C_p = \text{Specific heat of water} \sim 1.00 \text{ Btu}/(\text{lb}_m \text{ } ^\circ\text{F})$$

$$m = Q/(C_p\Delta T)$$

$$m = 859 \times 10^6 \text{ Btu/hr} / [(1.00 \text{ Btu}/(\text{lb}_m \text{ } ^\circ\text{F}) \times (1 \text{ } ^\circ\text{F})]$$

$$m = 859 \times 10^6 \text{ lb}_m\text{/hr}$$

$$m = 859 \times 10^6 \text{ lb}_m\text{/hr} \times (\text{ft}^3/62.4 \text{ lb}_m) \times (\text{hr}/3600 \text{ sec})$$

$$m \sim 3800 \text{ cfs}$$