



ANP-10264NP  
Revision 0

**U.S. EPR Piping Analysis and Pipe Support Design  
Topical Report**

**September 2006**

AREVA NP Inc.

---

Non-Proprietary

(c) 2006 AREVA NP Inc.

**Copyright © 2006**

**AREVA NP Inc.  
All Rights Reserved**

The design, engineering and other information contained in this document have been prepared by or on behalf of AREVA NP Inc., a jointly owned subsidiary of AREVA and Siemens, in connection with its request to the U.S. Nuclear Regulatory Commission for a pre-application review of the U.S. EPR nuclear power plant design. No use of or right to copy any of this information, other than by the NRC and its contractors in support of AREVA NP's pre-application review, is authorized.

The information provided in this document is a subset of a much larger set of know-how, technology and intellectual property pertaining to an evolutionary pressurized water reactor designed by AREVA NP and referred to as the U.S. EPR. Without access and a grant of rights to that larger set of know-how, technology and intellectual property rights, this document is not practically or rightfully usable by others, except by the NRC as set forth in the previous paragraph.

For information address: AREVA NP Inc.

An AREVA and Siemens Company

3315 Old Forest Road

Lynchburg, VA 24506

## **U.S. Nuclear Regulatory Commission**

### **Disclaimer**

#### **Important Notice Concerning the Contents and Application of This Report**

##### ***Please Read Carefully***

This report was developed based on research and development funded and conducted by AREVA NP, Inc., and is being submitted by AREVA NP to the U.S. Nuclear Regulatory Commission (NRC) to facilitate future licensing processes that may be pursued by licensees or applicants that are customers of AREVA NP. The information contained in this report may be used by the NRC and, under the terms of applicable agreements with AREVA NP, those customers seeking licenses or license amendments to assist in demonstrating compliance with NRC regulations. The information provided in this report is true and correct to the best of AREVA NP's knowledge, information, and belief.

AREVA NP's warranties and representations concerning the content of this report are set forth in agreements between AREVA NP and individual customers. Except as otherwise expressly provided in such agreements with its customers, neither AREVA NP nor any person acting on behalf of AREVA NP:

- Makes any warranty or representation, express or implied, with respect to the accuracy, completeness, or usefulness of the information contained in this report, nor the use of any information, apparatus, method, or process disclosed in this report.
- Assumes any liability with respect to the use of or for damages resulting from the use of any information, apparatus, method, or process disclosed in this report.

### Nature of Changes

Item	Section(s) or Page(s)	Description and Justification
------	--------------------------	-------------------------------

---

## Contents

	<u>Page</u>
<b>1.0 INTRODUCTION .....</b>	<b>1-1</b>
<b>2.0 CODES AND STANDARDS.....</b>	<b>2-1</b>
2.1 ASME Boiler and Pressure Vessel Code .....	2-1
2.2 ASME Code Cases .....	2-1
2.3 Design Specification .....	2-2
<b>3.0 PIPING STRESS ANALYSIS CRITERIA .....</b>	<b>3-1</b>
3.1 Piping Seismic Classifications .....	3-1
3.2 Service Levels .....	3-1
3.2.1 Level A (Normal) .....	3-2
3.2.2 Level B (Upset) .....	3-2
3.2.3 Level C (Emergency) .....	3-2
3.2.4 Level D (Faulted).....	3-2
3.2.5 Testing .....	3-3
3.3 Loadings and Load Combinations .....	3-3
3.3.1 Loadings .....	3-3
3.3.2 Load Combinations .....	3-6
3.4 Fatigue Evaluation .....	3-6
3.4.1 Code Class 1 Piping.....	3-6
3.4.2 Code Class 2 and 3 Piping.....	3-7
3.5 Functional Capability.....	3-7
3.6 Welded Attachments.....	3-8
3.7 Thermal Stratification (Thermal Stratification, Cycling and Striping) .....	3-8
3.7.1 NRC Bulletin 79-13 (Feedwater Lines).....	3-8
3.7.2 NRC Bulletin 88-11 (Surge Line).....	3-9
3.7.3 NRC Bulletin 88-08 (Unisolable piping due to leaking valves) .....	3-9
3.8 Design and Installation of Pressure Relief Devices .....	3-9
3.8.1 Design and Installation Criteria .....	3-9
3.8.2 Analysis Requirements for Pressure Relieving Devices.....	3-10
3.9 Intersystem LOCA .....	3-10
3.10 Seismic Category I Buried Pipe .....	3-11
<b>4.0 PIPING ANALYSIS METHODS .....</b>	<b>4-1</b>
4.1 Experimental Stress Analysis .....	4-1
4.2 Seismic Analysis Methods .....	4-1
4.2.1 Seismic Input.....	4-1
4.2.2 Response Spectrum Method.....	4-1
4.2.3 Time History Method .....	4-9
4.2.4 Equivalent Static Load Method .....	4-10
4.2.5 Damping Values.....	4-11
4.3 Inelastic Analysis Methods.....	4-11

4.4	Non-Seismic/Seismic Interaction .....	4-12
4.4.1	Isolation of Seismic and Non-Seismic Systems .....	4-12
4.4.2	Interaction Evaluation.....	4-13
<b>5.0</b>	<b>PIPING MODELING TECHNIQUES.....</b>	<b>5-1</b>
5.1	Computer Codes.....	5-1
5.1.1	SUPERPIPE .....	5-1
5.1.2	BWSPAN .....	5-1
5.1.3	BWHIST .....	5-2
5.1.4	BWSPEC .....	5-2
5.1.5	COMPAR2 .....	5-2
5.1.6	CRAFT2 .....	5-2
5.1.7	P91232 .....	5-3
5.1.8	RESPECT .....	5-3
5.2	Dynamic Piping Model .....	5-3
5.3	Piping Benchmark Program .....	5-5
5.4	Model Boundaries .....	5-5
5.4.1	Structural Boundaries.....	5-5
5.4.2	Decoupling Criteria.....	5-7
5.4.3	Model Isolation Methods .....	5-8
5.5	Seismic/Non-Seismic Interface Boundaries .....	5-10
<b>6.0</b>	<b>PIPE SUPPORT DESIGN CRITERIA .....</b>	<b>6-1</b>
6.1	Applicable Codes .....	6-1
6.2	Jurisdictional Boundaries .....	6-2
6.3	Loads and Load Combinations .....	6-3
6.3.1	Deadweight (D) Loads .....	6-3
6.3.2	Thermal ( $T_N$ , $T_U$ , $T_E$ , $T_F$ ) Loads.....	6-4
6.3.3	Friction (F) Loads .....	6-5
6.3.4	System Operating Transient ( $R_{SOT}$ ) Loads.....	6-5
6.3.5	Wind (W) Loads .....	6-5
6.3.6	Tornado ( $W_T$ ) Loads.....	6-5
6.3.7	Design Basis Pipe Break ( $R_{DBPB}$ ) Loads .....	6-6
6.3.8	Main Steam / Feedwater Pipe Break ( $R_{MS/FWPB}$ ) Loads.....	6-6
6.3.9	Loss of Coolant Accident (LOCA) Loads.....	6-6
6.3.10	Safe Shutdown Earthquake (SSE) Loads .....	6-7
6.3.11	Minimum Design Loads.....	6-7
6.4	Pipe Support Baseplate and Anchor Bolt Design.....	6-7
6.5	Use of Energy Absorbers and Limit Stops .....	6-8
6.6	Use of Snubbers .....	6-8
6.7	Pipe Support Stiffnesses.....	6-9
6.8	Seismic Self-Weight Excitation .....	6-10
6.9	Design of Supplemental Steel.....	6-10
6.10	Consideration of Friction Forces .....	6-11
6.11	Pipe Support Gaps and Clearances .....	6-11
6.12	Instrumentation Line Support Criteria .....	6-12

---

6.13	Pipe Deflection Limits .....	6-12
<b>7.0</b>	<b>SUMMARY/CONCLUSIONS.....</b>	<b>7-1</b>
<b>8.0</b>	<b>REFERENCES.....</b>	<b>8-1</b>

---

**List of Tables**

	<u>Page</u>
Table 1-1: Analysis and Design Responsibilities for COL Applicants .....	1-3
Table 3-1: Design Conditions, Load Combination and Stress Criteria for ASME Class 1 Piping .....	3-12
Table 3-2: Design Conditions, Load Combination and Stress Criteria for ASME Class 2&3 Piping .....	3-16
Table 3-3: Functional Capability of Piping ASME Class 1, 2 & 3 <sup>(1)</sup> .....	3-17
Table 3-4: Design Conditions, Load Combination and Stress Criteria for ASME Class 2&3 Buried Piping .....	3-18
Table 4-1: Suggested Deadweight Pipe Support Spacing .....	4-15
Table 6-1: Loading Combinations for Piping Supports .....	6-13



## List of Figures

	<u>Page</u>
Figure 5-1: Restrained Elbow.....	5-12
Figure 5-2: Restrained Tee .....	5-13
Figure 5-3: Model Isolation Methods of Division.....	5-14

---

**Nomenclature**

<u>Acronym</u>	<u>Definition</u>
ACI	American Concrete Institute
AISC	American Institute of Steel Construction
ANSI	American National Standards Institute
ARS	Amplified Response Spectra
ASME	American Society of Mechanical Engineers
AWS	American Welding Society
CFR	Code of Federal Regulations
COL	Combined Construction Permit and Operating License
DBPB	Design Basis Pipe Break
DCD	Design Control Document
DFL	Dynamic Fluid Load
DLF	Dynamic Load Factor
GDC	General Design Criterion
ISM	Independent Support Motion
LBB	Leak-Before-Break
LOCA	Loss-of-Coolant Accident
MS/FWPB	Main Steam / Feedwater Pipe Break
NPS	Nominal Pipe Size
NRC	U.S. Nuclear Regulatory Commission
OBE	Operating Basis Earthquake
RCL	Reactor Coolant Loop
RG	Regulatory Guide

---

SAM	Seismic Anchor Motion
SIF	Stress Intensification Factor
SIR	Stress Intensity Range
SOT	System Operating Transient
SRP	Standard Review Plan
SRSS	Square Root of the Sum of the Squares
SSC	Structures, Systems and Components
SSE	Safe Shutdown Earthquake
TAM	Thermal Anchor Movement
USM	Uniform Support Motion
ZPA	Zero Period Acceleration

## 1.0 INTRODUCTION

This topical report presents the U.S. EPR Design Certification code requirements, acceptance criteria, analysis methods and modeling techniques for ASME Class 1, 2 and 3 piping and pipe supports. These structures and components are designed and analyzed as required to meet the U.S. Nuclear Regulatory Commission's (NRC) regulations provided in Title 10 of the Code of Federal Regulations (10 CFR). To meet these requirements, the design and analysis utilizes the additional guidance provided by Sections 3.7 and 3.9 of the NRC's Standard Review Plan (SRP), documented in NUREG-0800,<sup>[1]</sup> and the requirements established in the American Society of Mechanical Engineers Boiler and Pressure Vessel Code, Section III, Division 1 (hereafter, ASME Code) for Code Class 1, 2 and 3 pressure retaining components and their supports. The report focuses on Seismic Category I and Category II systems, but also addresses the interaction of non-seismic piping with Seismic Category I piping. The Reactor Coolant Loop (RCL) and Pressurizer Surge Line piping requirements, modeling techniques, analysis approaches and acceptance criteria are not specifically addressed in this document. They will be addressed in the Design Control Document.

Section 2.0 identifies the codes and standards applicable to the U.S. EPR design and analysis of piping and pipe supports. In addition, it identifies the Code Cases that will be used for piping analysis and support design.

Section 3.0 of this report presents the piping analysis acceptance criteria. It identifies the categorization of piping according to the guidance provided in Regulatory Guide 1.29, service level and load definitions and load combinations used in the qualification of piping. In addition, it discusses how the U.S. EPR piping will be designed to address additional issues related to pipe stress analysis.

Section 4.0 focuses on seismic analysis methods guided primarily by SRP 3.7.3. This section presents discussions on such topics as seismic input, response spectrum and time history analysis, damping values and equivalent static analysis. Seismic and non-seismic interactions are also discussed.

---

Section 5.0 presents pipe modeling techniques used in the qualification of piping for the U.S. EPR. Computer codes used in piping analysis are identified in this section with a brief description of each. Analysis boundaries, decoupling criteria and other modeling requirements are presented.

Section 6.0 presents the pipe support design criteria. Codes and standards and load combinations along with deflection criteria, stiffness and general support configurations are presented.

Conclusions are discussed in Section 7.0.

This topical also identifies some requirements and guidelines for which the COL applicant is responsible. The specific issues are identified in Table 1-1.

**Table 1-1: Analysis and Design Responsibilities for COL Applicants**

ITEM	COL Applicant Responsibility	Applicable Section
1	COL applicant will identify any additional Code Cases used that are not listed in this Topical Report for piping not included in the scope of the U.S. EPR Design Certification.	2.2
2	The COL applicant will develop the design specification and the design reports using requirements outlined in the Code and demonstrate and document that as-built piping and support configurations adhere to the requirements of the design specification.	2.3
3	Should the COL applicant find it necessary to route Class 1, 2 and 3 piping not included in the U.S. EPR Design Certification in such a manner that it is exposed to wind and/or tornadoes, it must be designed to withstand the plant design basis loads for this event	3.3.1.6
4	The COL applicant will confirm that thermal deflections do not create adverse conditions on the pressurizer surge line during hot functional testing.	3.7.2
5	A review of the impact of contributing mass of supports on the piping analysis will need to be performed by the COL applicant(s) following the final support design to confirm that the mass of the support is no more than 10% of the mass of the adjacent pipe span.	5.2
6	Pipe stress and support analysis will be performed by the COL applicant(s). A COL applicant choosing to use a piping analysis program other than those listed in Section 5.1 will implement the NRC benchmark program using models specifically selected for the U.S. EPR.	5.3
7	The COL Applicant will verify proper installation and operation of snubbers utilizing visual inspections, hot and cold position measurements, and observance of thermal movements during plant startup.	6.6

## **2.0 CODES AND STANDARDS**

10 CFR Part 50, Appendix A, General Design Criterion (GDC) 1 requires that structures, systems and components (SSC) important to safety must be designed to quality standards “commensurate with the importance of the safety functions to be performed.” GDC 2 requires that SSCs important to safety be designed to withstand the effects of natural phenomena such as earthquakes, tornadoes and floods without the loss of their safety function. Codes and standards used to show that safety-related piping and pipe supports for the U.S. EPR meet these GDCs are identified below.

### **2.1 ASME Boiler and Pressure Vessel Code**

Piping analysis and pipe support design for the U.S. EPR addressed in this topical use the 2001 ASME Code, Section III, Division 1, 2003 addenda<sup>[2]</sup> as the base code with restrictions identified in the Code of Federal Regulations, 10 CFR 50.55a(b)(1). Accordingly, the 2001 Edition of the ASME Code, 2003 addenda, will be the design code for Class 1, 2, and 3 piping with the restriction that the treatment of dynamic loads, including seismic loads, in the pipe stress analyses will be according to sub-articles NB/NC/ND-3650 of the 1993 Addenda of the ASME Code<sup>[3]</sup>. Class 1 piping greater than one inch Nominal Pipe Size (NPS) will be analyzed to NB-3600. Class 1 piping one inch NPS and smaller and Class 1 piping meeting the requirements of NB-3630(d)(2) may be analyzed to NC-3600. Class 2 piping will be analyzed to NC-3600. Class 3 piping will be analyzed to ND-3600. Pipe supports will be designed to Subsection NF of the 2001 ASME Code, Section III, 2003 addenda.

### **2.2 ASME Code Cases**

ASME Code Cases applicable to the U.S. EPR Design Certification for piping and pipe supports are as follows:

- ASME Code Case N-122-2, ‘Procedure for Evaluation of the Design of Rectangular Cross Section Attachments on Class 1 Piping, Section III, Division 1.’

- ASME Code Case N-318-5, 'Procedure for Evaluation of the Design of Rectangular Cross Section Attachments on Class 2 or 3 Piping, Section III, Division 1.'
- ASME Code Case N-319-3, 'Alternate Procedure for Evaluation of Stresses in Butt Welding Elbows in Class 1 Piping Section III, Division 1.'
- ASME Code Case N-391-2, 'Procedure for Evaluation of the Design of Hollow Circular Cross Section Welded Attachments on Class 1 Piping, Section III, Division 1.'
- ASME Code Case N-392-3, 'Procedure for Evaluation of the Design of Hollow Circular Cross Section Welded Attachments on Class 2 and 3 Piping, Section III, Division 1.'

Other ASME Code Cases may be used in the Design Certification if they are either conditionally or unconditionally approved in Regulatory Guide (RG) 1.84<sup>[4]</sup>. In addition, new Code Cases may be used by the Combined Construction Permit and Operating License (COL) applicant if they are included in RG 1.84<sup>[4]</sup>.

### **2.3      *Design Specification***

A design specification is required by Section III of the ASME Code<sup>[2]</sup> for ASME Class 1, 2 and 3 piping. In addition, the ASME Code requires design reports for all Class 1, 2 and 3 piping demonstrating and documenting that as-built piping and support configurations adhere to the requirements of the design specification. It is the responsibility of the COL applicant or his agent to develop the design specification and the design reports using requirements outlined in the ASME Code.



### **3.0 PIPING STRESS ANALYSIS CRITERIA**

#### **3.1 *Piping Seismic Classifications***

The U.S. EPR follows the guidance in RG 1.29, "Seismic Design Classification,"<sup>[5]</sup> in classifying structures, systems and components (SSCs) as Seismic Category I, Seismic Category II or non-seismic. The following definitions apply to these categories for piping:

- Seismic Category I piping is required to be designed to withstand the effects of a Safe Shutdown Earthquake (SSE) and remain functional during and after the event. These components must meet the requirements of Appendix B to 10 CFR Part 50.
- Piping that is not required to function during or after an SSE event, but its structural failure could reduce the functioning of Seismic Category I SSCs is classified as Seismic Category II piping. To prevent adverse impact to Seismic Category I SSCs, Seismic Category II piping will be designed to the same requirements as Seismic Category I piping.
- Piping that does not meet the criteria for Seismic Category I or II is considered non-seismic. Non-seismic pipe is routed away from safety equipment to prevent any interaction with Seismic Category I and II, where applicable. When it is not practical to route non-seismic pipe away from Seismic Category I and II piping, the non-seismic piping will be upgraded to Seismic Category II as defined above.

#### **3.2 *Service Levels***

The U.S. EPR will utilize the four Service Levels used in the ASME Code, Levels A, B, C and D, and testing conditions, in its design of piping and pipe supports. These four service level designations also have the alternate naming convention of Normal, Upset, Emergency and Faulted, respectively. Based on the guidance in SRP 3.9.3<sup>[1]</sup>, loading

combinations of the various potential analysis load cases will be developed for the four defined levels. The general definitions of each of the four levels are as follows:

### **3.2.1 Level A (Normal)**

Level A refers to sustained loadings encountered during normal plant/system start-up, operation, refueling and shutdown.

### **3.2.2 Level B (Upset)**

Level B refers to occasional, infrequent loadings deviating from normal plant conditions, but having a high probability of occurrence. Piping and pipe supports will be designed to withstand these loading conditions without sustaining any damage or reduction in function.

### **3.2.3 Level C (Emergency)**

Level C refers to infrequent loadings with a low probability of occurrence, which are considered as design basis loadings causing no significant loss of integrity. Such an occurrence requires the unit to be shut down for inspection and repair to any damaged components prior to re-start.

### **3.2.4 Level D (Faulted)**

Level D refers to infrequent loadings with an extremely low probability of occurrence, associated with design basis accidents (such as Safe Shutdown Earthquake, Design Basis Pipe Break and Loss of Coolant Accident). Per RG 1.29<sup>[5]</sup>, SSCs important to safety must retain their ability where required to “ensure:

- the integrity of the reactor coolant pressure boundary
- the capability to shut down the reactor and maintain it in a safe shutdown condition

- the capability to prevent or mitigate the consequences of accidents that could result in potential offsite exposures comparable to the guideline exposures of 10 CFR Part 100.”

### **3.2.5 Testing**

Pressure overload tests such as primary and secondary hydrotests and other leak rate tests are included in the piping analysis for primary membrane stresses and fatigue evaluation.

## **3.3 Loadings and Load Combinations**

### **3.3.1 Loadings**

#### **3.3.1.1 Pressure**

Internal design pressure,  $P$ , is used in the design and analysis of ASME Code Class 1, 2 & 3 piping. Minimum pipe wall thickness calculations are performed per ASME Code, Subsections NB-, NC-, ND-3640 utilizing design pressure. Design pressures and maximum service pressures are used in load combinations as noted in Tables 3-1 and 3-2 for calculating stresses for Design Conditions, Service Levels A, B, C and D and Testing.

#### **3.3.1.2 Deadweight**

Deadweight loads will be calculated by applying a 1g negative vertical acceleration to the pipe, contents, insulation and in-line components. The weight of water during hydrostatic testing shall be considered for piping systems carrying air, steam or gas.

#### **3.3.1.3 Thermal Expansion**

The effects on piping and supports from restrained thermal expansion and contraction shall be considered in the design. Various operating modes shall be considered in order to determine the most severe thermal loading conditions. Thermal anchor

movements of equipment, support/restraints and run piping for decoupled branch lines shall also be considered. The zero thermal load temperature is taken as 70°F.

No thermal analysis is required for piping systems with an operating temperature equal to or less than 150°F<sup>[2]</sup>. Additionally, thermal anchor movements less than or equal to one sixteenth of an inch (1/16") may be excluded from the analysis since this represents the industry practice for acceptable gaps in pipe supports.<sup>[6]</sup>

#### **3.3.1.4 Seismic**

The effects of seismic inertial loads and anchor movements shall be included in the design analysis.

The ground motion of the Operating Basis Earthquake (OBE) for the U.S. EPR is equal to one third of the ground motion of the SSE. Per Appendix S to 10 CFR Part 50, the OBE load case does not require explicit design analysis. In the event of an earthquake which meets or exceeds the OBE ground motion, plant shutdown is required and Seismic Category I piping and supports are required to be inspected to ensure no functional damage has occurred. The design of the U.S. EPR Seismic Category I piping and supports includes analysis of the inertial and anchor movement effects of the SSE event. These loads are Service Level D loads.

The consideration of fatigue effects due to seismic events is discussed in Section 3.4.

#### **3.3.1.5 Fluid Transient Loadings**

##### **3.3.1.5.1 Relief Valve Thrust**

Relief valve thrust loads, for open and closed systems, are functions of valve opening time, flow rate, fluid properties and flow area. The analysis of these loads is usually accomplished using static loads as input to the piping analysis with appropriate dynamic load factors. Dynamic analysis of relief valve thrusts will be used when static analysis produces undesirably conservative results. These loads are considered in Service Level B, C or D load combinations.

---

**3.3.1.5.2 Water and Steam Hammer**

Water and steam hammer loads can be Service Level B, C or D loads and are dynamic in nature. Hammers usually involve the rapid change in fluid flow creating a “shock wave” effect in the piping system. They are usually set in motion by rapid actuation of control valves, relief valves and check valves. Rapid start or trip of a pump or turbine can also initiate such a phenomenon.

**3.3.1.6 Wind/Tornado Loads**

Class 1, 2 and 3 piping for the U.S. EPR Design Certification is not exposed to wind or tornado loads. Should the COL applicant find it necessary to route piping outside the scope of the design certification in such a manner that it is exposed to wind and/or tornadoes, it must be designed to the plant design basis loads for these events.

**3.3.1.7 Design Basis Pipe Break (DBPB) Loads**

Loads due to high energy pipe breaks can take the form of pipe whip, jet impingement, elevated room temperatures and the dynamic effects in the system due to the break. These loads must be evaluated for the appropriate service condition. Breaks in the RCL, Main Steam and Pressurizer Surge lines which meet the Leak-Before-Break (LBB) size criteria are eliminated from consideration based on LBB analysis. However, DBPB loads do include the impact of small break LOCA, Main Steam and Feedwater line breaks outside the LBB analyzed zone.

**3.3.1.8 Thermal and Pressure Transient Loads**

Thermal and pressure transients are evaluated in the analysis of Class 1 piping by calculating the range of primary plus secondary stress intensities. For Class 2&3 piping, these transients are included as load cases in the appropriate ASME Code equations (8, 9 or 10).

### **3.3.1.9 Hydrotests**

Piping systems are tested for leaks by filling the system with the test fluid and pressurizing to test pressures. Systems that are normally used for steam and gas services must have stops placed in spring hangers and temporary supports added as needed. Analysis of testing conditions for these lines must consider the temporary support configurations

### **3.3.2 Load Combinations**

Using the methodology and equations from the ASME Code, pipe stresses shall be calculated for various load combinations. The ASME Code includes design limits for Design Conditions, Service Levels A, B, C and D and testing. Load combinations for Class 1 piping are given in Table 3-1. Class 2 and 3 load combinations are given in Table 3-2.

## **3.4 Fatigue Evaluation**

### **3.4.1 Code Class 1 Piping**

Class 1 piping shall be evaluated for the effects of fatigue as a result of pressure and thermal transients and other cyclic events including earthquakes. The fatigue analysis of Class 1 piping greater than 1 inch NPS is performed using the ASME Code requirements of NB-3653.

Per the guidance of SRP 3.7.3<sup>[1]</sup>, Class 1 piping should be designed for a minimum of one SSE and five OBE events with ten maximum stress cycles per event. As discussed in Section 3.3.1.4, a detailed design analysis of the OBE loadcase is not performed for the U.S. EPR. Therefore, to meet this requirement, earthquake cycles included in the fatigue analysis are composed of 2 SSE events with 10 maximum stress-cycles each for a total of 20 full cycles of SSE stress range. Alternatively, as allowed by NRC memo SECY-93-087 <sup>[7]</sup>, the methods of Appendix D of IEEE Standard 344-1987 <sup>[8]</sup> may be used to determine a number of fractional vibratory cycles equivalent to 20 full SSE

cycles. When this method is used, the amplitude of the vibration is taken as one third of the amplitude of the SSE resulting in 300 fractional SSE cycles to be considered.

The effects of the reactor coolant environment on fatigue will be accounted for in the Class 1 piping fatigue analyses using methods acceptable to the NRC at the time of performance.

### **3.4.2 Code Class 2 and 3 Piping**

Class 2 and 3 piping is evaluated for fatigue due to thermal cycles by following the requirements in NC-3611.2. This involves the reduction of ASME Code allowables for the thermal expansion stresses calculated to the requirements in NC/ND-3653.2(a) by a factor,  $f$ , as determined in Table NC/ND-3611.2(e)-1, "Stress Range Reduction Factors." In addition, the stress intensification factors (SIFs) and stress indices used in ASME Code equations for calculating stresses at components are based on fatigue testing and, therefore, indirectly account for fatigue in Class 2 and 3 piping components. No cumulative usage factor is calculated for Class 2 & 3 piping..

Environmental impact on fatigue of Class 2 & 3 piping will follow guidelines established by the NRC at the time of analysis.

### **3.5 Functional Capability**

General Design Criterion 2 of 10 CFR Part 50 requires that all Class 1, 2 & 3 piping systems essential for safe shutdown of the plant remain capable of performing their safety function for all Service Level D loading conditions. This criterion is met by meeting the recommendations in NUREG-1367, "Functional Capability of Piping Systems."<sup>[9]</sup>

The NUREG-1367<sup>[9]</sup> provision that the dynamic moments be "calculated using an elastic response spectrum analysis with +/-15% peak broadening and with not more than 5% damping" will be considered met for piping analyzed by elastic time history methods as

long as: 1) uncertainties in the applied time histories are accounted for, and 2) pipe damping used is not more than 5%.

Table 3-3 summarizes the criteria to be used to ensure that the functional capability requirement of GDC 2 is met.

### **3.6      *Welded Attachments***

Support and restraint designs that require welded attachments to the pipe for transfer of the pipe loads to the supporting structure will adhere to industry practices and ASME Code Cases identified in Section 2.2 of this document.

### **3.7      *Thermal Stratification (Thermal Stratification, Cycling and Striping)***

#### **3.7.1    *NRC Bulletin 79-13 (Feedwater Lines)***

NRC Bulletin 79-13<sup>[10]</sup> was issued as a result of a feedwater line cracking incident at D.C. Cook Nuclear Plant Unit 2 which led to the discovery of cracks in numerous other plants. The primary cause of the cracking was determined to be thermal fatigue loading due to thermal stratification and high-cycle thermal striping during low flow emergency feedwater injection.

For the U.S. EPR, the steam generators and main feedwater lines are designed to minimize thermal stratification. There are separate nozzles on the steam generator for the main feedwater and emergency feedwater connections. Pipe runs are relatively short. The main feedwater nozzle is located in the conical section of the steam generator which aids in reducing thermal stratification.

The effects of thermal stratification and striping will be evaluated during the evaluation of the main feedwater system and the evaluation will confirm that all load cases meet the ASME Code allowables.



### **3.7.2 NRC Bulletin 88-11 (Surge Line)**

NRC Bulletin 88-11<sup>[11]</sup> requires consideration of the effects of thermal stratification on the pressurizer surge line. The surge line on the U.S. EPR will be analyzed with the RCL piping and supports. The effects of thermal stratification and striping will be evaluated as part of this analysis or it will be demonstrated that the surge line is not subjected to significant stratification/stripping effects due to design features that mitigate these effects. The COL applicant will confirm that thermal deflections do not create adverse conditions during hot functional testing.

### **3.7.3 NRC Bulletin 88-08 (Unisolable piping due to leaking valves)**

Unisolable sections of piping connected to the RCL will be evaluated to determine if thermal stratification and striping caused by a leaking valve are plausible, as discussed in NRC Bulletin 88-08<sup>[12]</sup>. Contributions to fatigue from thermal stratification and striping will be considered where it is determined that these phenomena are plausible.

## **3.8 Design and Installation of Pressure Relief Devices**

### **3.8.1 Design and Installation Criteria**

The design and installation of safety valves and relief valves for overpressure protection are performed to the criteria specified in Appendix O of the ASME Code, "Rules for the Design of Safety Valve Installations," 2001 Edition, 2003 addenda. In addition, the following additional requirements must be met:

- Where more than one relief device is placed on the same header, instantaneous stresses in the pipe and support loads are calculated using the most adverse sequence of valve openings.
- Stresses are evaluated for all components, (pipe, valves, supports, welds and connecting systems) for the most adverse valve sequence.

- Stresses calculated as a result of valve reaction forces utilize dynamic or static calculation methods. If static methods are utilized, a Dynamic Load Factor (DLF) of 2.0 will be used.
- Stress and load combination requirements are specified in Table 3-1 and Table 3-2 for Class 1 and Class 2/3 piping, respectively.

### **3.8.2     *Analysis Requirements for Pressure Relieving Devices***

#### **3.8.2.1    *Open Discharge***

Safety or Relief Valves that discharge directly to the atmosphere are considered open discharge configurations. Discharge forces are usually calculated using static methods with a DLF of 2.0. These static loads are then applied to the valve discharge in the piping analysis to evaluate stresses and support designs. Snubbers are considered engaged for this analysis.

#### **3.8.2.2    *Closed Discharge***

Relief or safety valves with discharges piped to headers or tanks are analyzed with no steady state thrust forces but must be analyzed for intermediate forces acting on elbows and tees during the initial phase of the release. These forces are similar to water hammer and steam hammer due to the instantaneous opening of the valves and shall be evaluated with other load cases impacting the piping systems.

### **3.9        *Intersystem LOCA***

Low pressure piping systems that interface with the RCL and are thus subjected to the full RCL pressure will be designed for the maximum operating pressure of the RCL. The appropriate minimum wall thickness of the piping will then be calculated for each system using Equation 1 of NB-3640 of the ASME Code for Class 1 piping or Equation 3 of NC/ND-3640 for Class 2/3 piping. The piping will be analyzed to the requirements in NB/NC/ND-3650.

---

**3.10 Seismic Category I Buried Pipe**

Class 2 and 3 Seismic Category I buried piping systems in the U.S. EPR will be analyzed for pressure, weight, thermal expansion and seismic loads using dynamic or equivalent static load methods. The acceptance criteria are the same as that used for non-buried piping systems described in Table 3-2 with additional consideration of the following differences:

- Deformations imposed by either seismic waves traveling through the surrounding soil or by differential deformations between the soil and anchor points and lateral earth pressures acting on buried piping will be considered.
- The effects of static resistance of the surrounding soil on piping deformations or displacements, anchor movements and pipe geometry will be considered using the theory of structures on elastic foundations.
- The effects of local soil settling will be considered when applicable.
- It is also assumed that soil liquefaction and fault displacement will be avoided.
- Seismic loads experienced by buried piping are primarily generated by soil strains and therefore are self-limiting and considered secondary in nature.

Design conditions, load combinations and stress criteria to be used in the qualification of buried piping are addressed in Table 3-4.

**Table 3-1: Design Conditions, Load Combination and Stress Criteria for ASME Class 1 Piping**

Loading Condition	Service Level	Category	Loading	Stress Criteria <sup>(9)</sup>
Design	-	Primary Stress	Design Pressure, Deadweight, Other Design Mechanical Loads <sup>1</sup> (including any Dynamic Fluid Load (DFL) <sup>2</sup> specified as Level A)	Eq 9 NB-3652
Normal	A	Primary plus Secondary Stress Intensity Range (SIR)	Range of Level A: Service Pressure, Mechanical Load (including any DFL <sup>2</sup> specified as Level A), Thermal Expansion Load, Cyclic Anchor Motion Load (DFL and Thermal), Discontinuity Stress (Structural and Material)	Eq 10 NB-3653.1
		Peak SIR	Same as for Level A Primary plus Secondary SIR <u>plus</u> Range of Level A Thermal Radial Gradient Stress	Eq 11 NB-3653.2
		Thermal Bending SIR	Range of Level A: Thermal Expansion and Thermal Anchor Motion Loads <sup>4</sup>	Eq 12 NB-3653.6(a)
		Primary plus Secondary Membrane plus Bending SIR	Same as for Level A Primary plus Secondary SIR <u>except</u> Range of Level A Thermal Expansion and Thermal Anchor Motion Loads are not Considered <sup>4</sup>	Eq 13 NB-3653.6(b)
		Alternating Stress Intensity (Fatigue)	Same as for Level A Peak SIR	Eq 14 NB-3653.6(c) NB-3653.4 NB-3653.5
		Thermal Stress Ratchet	Range of Level A Linear Thermal Radial Gradient	NB-3653.7

**Table 3-1: Design Conditions, Load Combination and Stress Criteria for ASME Class 1 Piping (Continued)**

Loading Condition	Service Level	Category	Loading	Stress Criteria
Upset	B	Permissible Pressure	Maximum Level B Service Pressure	NB-3654.1
		Primary Stress	Deadweight, Coincident Level B Service Pressure and Mechanical Load (including any DFL <sup>2</sup> specified as Level B)	Eq 9U NB-3654.2(a)
		Primary plus Secondary SIR	Same as for Level A Primary plus Secondary SIR ( <u>except</u> Level B Load and Stress Ranges are Used) <u>plus</u> Earthquake Inertial Load <sup>5,6</sup>	Eq 10 NB-3654.2(b)
		Peak SIR	Same as for Level B Primary plus Secondary SIR <u>plus</u> Range of Level B Thermal Radial Gradient Stress	Eq 11 NB-3654.2(b)
		Thermal SIR	Range of Level B: Thermal Expansion and Thermal Anchor Motion Loads <sup>4</sup>	Eq 12 NB-3654.2(b)
		Primary plus Secondary Membrane plus Bending SIR	Same as for Level B Primary plus Secondary SIR <u>except</u> Range of Level B Thermal Expansion and Thermal Anchor Motion Loads are not Considered <sup>4</sup>	Eq 13 NB-3654.2(b)
		Alternating Stress (Fatigue)	Same as for Level B Peak SIR	Eq 14 NB-3654.2(b)
		Thermal Stress Ratchet	Range of Level B Linear Thermal Radial Gradient	NB-3654.2(b)
		Deformation Limits	As Set Forth in the Design Specification	NB-3654.2(b)

**Table 3-1: Design Conditions, Load Combination and Stress Criteria for ASME Class 1 Piping (Continued)**

Loading Condition	Service Level	Category	Loading	Stress Criteria
Emergency	C	Permissible Pressure	Maximum Level C Service Pressure	NB-3655.1
		Primary Stress	Deadweight, Coincident Level C Service Pressure and Mechanical Load (including any DFL <sup>2</sup> specified as Level C)	Eq 9E NB-3655.2(a)
		Deformation Limits	As Set Forth in the Design Specification	NB-3655.3
Faulted	D	Permissible Pressure	Maximum Level D Service Pressure	NB-3656(a)(1)
		Primary Stress <sup>7</sup>	Deadweight, Coincident Level D Service Pressure and Mechanical Load (including any DFL <sup>2,3</sup> specified as Level D), Earthquake Inertial Load <sup>8</sup> , Earthquake Anchor Motion Load <sup>8</sup> , Design Basis Pipe Break Load <sup>3</sup>	Eq 9F NB-3656(a)(2)
Testing	-	Primary Membrane Stress Intensity	Test Pressure	NB-3657 NB-3226(b)
		Primary Membrane plus Bending Stress Intensity	Test Pressure	NB-3657 NB-3226(c)
		Alternating Stress (Fatigue)	Range of Test Pressure	NB-3657 NB-3226(e)

**Table 3-1: Design Conditions, Load Combination and Stress Criteria for ASME Class 1 Piping (Continued)**

## Notes:

1. Design Mechanical Loads are sustained Level A or B mechanical loads (excluding earthquake).
2. Dynamic Fluid Loads are occasional loads associated with hydraulic transients such as valve thrust, valve closure, water hammer or steam hammer.
3. Dynamic loads are to be combined considering timing and causal relationships. SSE and Design Basis Pipe Break (including Loss-of-Coolant Accident) shall be combined using the Square-Root-of-the-Sum-of-the-Squares method.
4. The Thermal and Primary plus Secondary Membrane plus Bending Stress Intensity Ranges (Equations 12 and 13) need only be calculated for those load sets that do not meet the Primary plus Secondary Stress Intensity Range (Equation 10) allowable.
5. The resultant moment calculated shall be the maximum of the resultant moment due to the full range of earthquake or the resultant moment due to the combination of half of the range of earthquake and all other applicable loads. See also Note 4.
6. The earthquake inertial load used in the Level B Stress Intensity Range and Alternating Stress calculations (Equations 10, 11, 13 and 14) shall be taken as 1/3 of the peak SSE inertial load or as the peak SSE inertial load. If the earthquake inertial load is taken as 1/3 of the peak SSE inertial load then the number of cycles to be considered for earthquake loading shall be 300 as derived in accordance with Appendix D of IEEE Standard 344-1987<sup>[8]</sup>. If the earthquake inertial load is taken as the peak SSE inertial load then 20 cycles of earthquake loading shall be considered.
7. The rules given in Appendix F of the ASME Boiler and Pressure Vessel Code may be used in lieu of those given in NB-3656(a) and NB-3656(b).
8. The earthquake inertial load used in the Level D Primary Stress (Equation 9F) calculations shall be taken as the peak SSE inertial load. The earthquake anchor motion load used in the Level D Primary Stress (Equation 9F) calculations shall be taken as the peak SSE anchor motion load.
9. Equations and paragraphs refer to the 2001 Edition of the ASME Code through 2003 Addenda.<sup>[2]</sup> However, dynamic loads are treated in accordance with the applicable subarticles of the 1993 Addenda of the ASME Code per the limitations of 10 CFR 50.55a(b)(1).

**Table 3-2: Design Conditions, Load Combination and Stress Criteria for ASME Class 2&3 Piping**

Loading Condition	Service Levels	Loads	Stress Criteria (4) (9)
Design	-	Primary Stress Loads: Pressure, Weight, Other Sustained Mechanical Loads	Equation 8 NC/ND-3652
Normal/ Upset	A/B	Occasional: Pressure, Weight, Other Sustained Mechanical Loads, Dynamic Fluid Loads (DFL)(1), Wind (7)	Equation 9U NC/ND-3653.1 (Level B Only) (6)
		Secondary Stress: Thermal Expansion, TAM	Equation 10 NC/ND-3653.2(a) (2)
		Non-Repeated Anchor Movement	Equation 10a NC/ND-3653.2(b)
		Sustained Plus Secondary Stress: Pressure, Weight, Other Sustained Mechanical Loads, Thermal Expansion, TAM	Equation 11 NC/ND- 3653.2(c) (2)
Emergency	C	Occasional Stress: Pressure, Weight, DFL (1), Tornado (7)	Equation 9E NC/ND-3654.2(a)
Faulted	D	Occasional Stress: Pressure, Weight, DFL (1), SSE Inertia, Design Basis Pipe Break	Equation 9F NC/ND-3655(a)
		Secondary Stress: Thermal Expansion, TAM, Seismic Anchor Movement (SSE)	$\frac{iM_c}{Z} \leq \text{MIN}(3.0S_h, 2.0S_y)$ (6,8)

**Notes:**

- Dynamic Fluid Loads are occasional loads such as safety/relief valve thrust, steam hammer, water hammer, or other loads associated with Plant Upset, Emergency or Faulted Condition as applicable.
- Stresses must meet the requirements of either Equation 10 or 11, not both.
- If, during operation, the system normally carries a medium other than water (air, gas, steam), sustained loads should be checked for weight loads during hydrostatic testing as well as normal operation weight loads.
- ASME Boiler and Pressure Vessel Code, Section III.<sup>[2]</sup>
- Dynamic loads are combined by the square root of the sum of the squares (SRSS).
- OBE inertia and SAM loads are not included in the design of Class 2 & 3 piping<sup>[7]</sup>.
- Wind and tornado loads are not combined with earthquake loading.
- $M_c$  = Range of resultant moments due to thermal moments due to expansion and TAMs (Level A and B only) and SSE Seismic Anchor Movements (SAM).  $M_c$  is equal to the maximum moment range of either (a) the full range of thermal plus 1/2 the range of SAM, or (b) the full range of SAM.  $S_h$  is equal to the pipe material allowable stress at the operating temperature.  $S_y$  is equal to the pipe material yield stress at the operating temperature.
- ASME Code equations and paragraph numbers refer to the 2001 Edition through 2003 Addenda of the ASME Code. However, dynamic loads are treated in accordance with the applicable subarticles of the 1993 Addenda of the ASME Code per the limitations of 10 CFR 50.55a(b)(1).



**Table 3-3: Functional Capability of Piping ASME Class 1, 2 & 3<sup>(1)</sup>**

Criteria	Class 1		Class 2 & 3	
	Equation	Allowable	Equation	Allowable
Wall Thickness	$D_o/t \leq 50$	Meet	$D_o/t \leq 50$	Meet
Service Level D	Equation 9	Smaller of $2.0S_y$ or $3.0S_m^{(2)}$	Equation 9	Smaller of $2.0S_y$ or $3.0S_n^{(2)}$
External Pressure	$P_{\text{external}} \leq P_{\text{internal}}$	-	$P_{\text{external}} \leq P_{\text{internal}}$	-

**Notes:**

1. Applicable to Level D plant events for which the piping system must maintain an adequate fluid flow path.
2. Applicable to ASME Code Class 1, 2 & 3 when the following are met:
  - 2.1 Dynamic loads are reversing
  - 2.2 Steady-state bending stress from deadweight loads does not exceed:

$$\frac{B_2 M}{Z} \leq 0.25S_y$$

- 2.3 When elastic response spectrum analysis is used, dynamic moments are calculated using a minimum of 15% peak broadening and pipe damping is not more than 5%. When elastic time history analysis is used, uncertainties in the applied time histories are accounted for and pipe damping is not more than 5%.

**Table 3-4: Design Conditions, Load Combination and Stress Criteria for ASME Class 2&3 Buried Piping**

Loading Condition	Service Levels	Loads	Stress Criteria
Design	-	Primary Stress Loads: Pressure, Weight Loads <sup>(1)</sup> , Other Sustained Mechanical Loads	Equation 8 NC/ND-3652
Normal/ Upset	A/B	Occasional: Pressure, Weight Loads <sup>(1)</sup> , Other Sustained Mechanical Loads, DFL	Equation 9U NC/ND-3653.1 (Level B Only)
		Secondary Stress: Thermal Expansion, TAM, Thermal Friction Forces	Equation 10M <sup>(2) (4)</sup> NC/ND-3653.2(a)
		Non-Repeated Anchor Movement	Equation 10a NC/ND-3653.2(b)
		Sustained Plus Secondary Stress: Pressure, Weight Loads <sup>(1)</sup> , Other Sustained Mechanical Loads, Thermal Expansion, TAM, Thermal Friction Forces	Equation 11M <sup>(3) (4)</sup> NC/ND- 3653.2(c)
Emergency	C	Occasional Stress: Pressure, Weight Loads <sup>(1)</sup> , DFL	Equation 9E NC/ND-3654.2(a)
Faulted	D	Secondary Stress: SSE Inertia & SAM( $M_{SSE}$ ), Thermal Expansion ( $M_C$ ), Friction Axial Forces from Thermal Expansion ( $F_{a(T)}$ ), Friction Axial Forces from Seismic Loads ( $F_{a(SSE)}$ )	$\frac{i(M_{SSE} + M_c)}{Z} + \frac{(F_{a(SSE)} + F_{a(T)})}{A} \leq 3S_h$

**Notes:**

- Weight loads for buried pipe include the pipe weight (including contents and insulation, as well as soil overburden loads and loads due to motor vehicles and train cars.
- Equation 10 modified to include stress due to axial friction forces caused by thermal expansion and soil interaction.
- Equation 11 modified to include stress due to axial friction forces caused by thermal expansion and soil interaction.
- Stresses must meet Equation 10M or 11M, not both.
- Buried piping systems must be designed to meet the external pressure load criteria of NC/ND-3133 of the ASME Code.

## **4.0 PIPING ANALYSIS METHODS**

### **4.1 *Experimental Stress Analysis***

Experimental Stress Analysis will not be used to qualify piping for the U.S. EPR Design Certification.

### **4.2 *Seismic Analysis Methods***

Seismic Category I piping systems shall be designed to withstand the effects of a SSE and maintain the capability of performing their safety functions. This design will be accomplished by performing a seismic analysis for all Seismic Category I subsystems using methods in accordance with SRP 3.7.3<sup>[1]</sup>. These methods, as discussed below, include the Response Spectrum Method, Time History Method or, where applicable, the Equivalent Static Load Method.

#### **4.2.1 *Seismic Input***

The response spectra curves for the U.S. EPR are being developed to cover an appropriate range of possible soil conditions with the ground motion anchored to a peak ground acceleration of 0.3g. The ratio of the vertical design ground motion to the horizontal design ground motion is 1.0 for the U.S. EPR.

#### **4.2.2 *Response Spectrum Method***

The effects of the ground motion during an SSE event are transmitted through structures to the piping systems at support and equipment anchorage locations. In the response spectrum method of analysis, peak values of response are determined for each mode of the piping system by application of floor response spectra, which represent the maximum acceleration response of an idealized single-degree-of-freedom damped oscillator as a function of natural frequency to the vibratory input motion of the structure.

The floor response spectra are applied to the piping system at locations of structural attachment, such as support or equipment locations. The response spectra analysis is performed using either enveloped uniform response spectra or independent support motion using multiple spectra.

The floor response spectra are applied to the piping system in each of 3 orthogonal directions. Each of the directional components of earthquake motion input will in turn produce responses in the piping system in all three directions at each natural frequency of the piping system. The total seismic response of the system is determined by combining the modal and spatial results using the methods below.

#### **4.2.2.1 Development of Floor Response Spectrum**

In the response spectrum method of analysis, the design floor response spectra for the structures shall be generated according to RG 1.122<sup>[13]</sup>. The development of the floor response spectra will consider simultaneous earthquake accelerations acting in three orthogonal directions (two horizontal and one vertical).

The uncertainties in the structural frequencies due to uncertainties and approximations in the material and structural properties and modeling methods used in the development of the floor response spectrum shall be considered in the response spectrum analysis in one of two ways. Either the raw floor spectra will be smoothed and then peak broadened or, where a reduction in unnecessary conservatism is desired, the peak shifting method of analysis will be used.

##### **4.2.2.1.1 Peak Broadening Method**

Peak broadened response spectra shall be generated using the methods of RG 1.122<sup>[13]</sup>. In order to account for uncertainties in the structural response, response spectra will be peak broadened by a minimum of  $\pm 15\%$ .

**4.2.2.1.2 Peak Shifting Method**

Peak shifting analysis may be used in place of peak broadening in order to reduce unnecessary conservatism in the design. Similar to broadening, peak shifting will consider a minimum of  $\pm 15\%$  uncertainty in the peak structural frequencies. However, spectral shifting reduces the amount of conservatism by considering that the structural natural frequency is defined by a single value, not a range of values. Therefore, only one mode of the piping system can respond at the peak acceleration. <sup>[14]</sup>

In the peak shifting method, the natural frequencies of the piping system within the maximum peak acceleration broadened spectral frequency range defined above are determined. If no piping system natural frequencies exist within this frequency range, successively lower acceleration peaks are broadened until the first range containing at least one natural frequency of the piping is found.

Considering that the peak structural frequency may lie at any one frequency within the broadened range,  $N+3$  separate response spectra analyses are then performed, where  $N$  is the number of piping modes within the broadened frequency range. The first analysis uses the unbroadened response spectrum. The second and third analyses use the unbroadened spectrum modified by shifting the frequencies associated with each spectral value by  $-\Delta f_j$  and  $+\Delta f_j$ , where  $\Delta f_j$  is the amount of peak shifting required to account for the uncertainties of the structural response. The remaining  $N$  analyses also use the unbroadened spectrum modified by shifting the frequencies associated with each spectral value by a factor of:

$$1 + \frac{(f_e)_n - f_j}{f_j}$$

Where  $(f_e)_n$  = Piping system natural frequency occurring within the broadened range, for  $n = 1$  to  $N$ ,

$f_j$  = frequency at which the peak acceleration occurs (for the peak under consideration).

---

The modal results of each of these analyses are then combined separately using the combination procedures below. The final results are obtained by enveloping the results of the separate analyses.

Where three different floor spectrum curves are used to define the response of the structure, the peak shifting method is applied in each direction.

#### **4.2.2.2 *Multiply Supported Systems***

##### **4.2.2.2.1 *Uniform Support Motion***

Piping systems supported by multiple elevations within one or more buildings may be analyzed using Uniform Support Motion (USM). This analysis method applies a single set of spectra at all support locations which envelops all of the individual response spectra for these locations. An enveloped response spectrum is developed and applied for each of the three orthogonal directions of input motion.

The modal and directional responses are then combined as discussed in Sections 4.2.2.3 and 4.2.2.4, respectively. See Section 4.2.2.5 for consideration of relative displacements at support locations.

##### **4.2.2.2.2 *Independent Support Motion***

Independent Support Motion (ISM) may be used when piping systems are supported by multiple support structures or at multiple levels within a structure. In this method of analysis, supports are divided into support groups with different seismic excitation applied to each group. A support group is made up of supports that have the same time-history input. Typically, a support group is made up of supports attached to the same structure, floor or portion of a floor.

When using independent support motion, the seismic response of each mode is calculated by combining the responses of all support groups into one by using absolute summation method. The modal and directional responses are then combined as

discussed in Sections 4.2.2.3 and 4.2.2.4, respectively. See Section 4.2.2.5 for consideration of relative displacements at support locations.

Analyses performed using ISM shall use the RG 1.61<sup>[15]</sup> damping values (See Section 4.2.5).

### **4.2.2.3 Modal Combination**

The inertial response of a piping system in a seismic response spectrum analysis is considered in two parts. The modal analysis calculates the peak response of the piping system for all natural frequencies of the system below a defined cutoff frequency. These low frequency (or non-rigid) modes consist of all modes with seismic excitation frequencies up to the frequency at which spectral accelerations return to the zero period acceleration (ZPA). This frequency is referred to as the ZPA cutoff frequency. Higher ZPA cutoff frequencies may be required for other dynamic load cases.

At modal frequencies above that corresponding to the ZPA, pipe members are considered rigid. The acceleration associated with these rigid modes is usually small. However, in certain situations the response to high frequency modes can significantly affect support loads, particularly axial restraints on long piping runs. To account for these effects, a missing mass correction is applied.

#### **4.2.2.3.1 Low Frequency (Non-Rigid) Modes**

RG 1.92<sup>[16]</sup> provides guidance on combining the individual modal results due to each response spectrum in a dynamic analysis.

The combination method used shall consider the effects of closely spaced modes. Modes are defined as being closely spaced if their frequencies differ from each other by 10 percent or less of the lower frequency.

For piping systems with no closely spaced modes, the square root of the sum of the squares (SRSS) method is applied to obtain the representative maximum response of each element, as shown in the following equation:

$$R = \left[ \sum_{k=1}^N R_k^2 \right]^{\frac{1}{2}}$$

Where  $R$  = the representative maximum response due to the input component of the earthquake,

$R_k$  = the peak response due to the  $k^{\text{th}}$  mode,

$N$  = the number of significant modes.

This method may produce unconservative results for piping systems with closely spaced modes. Therefore, the approved methods for combining closely spaced modes provided in RG 1.92<sup>[16]</sup> will be used to obtain a more accurate modal response. These include the Grouping, Ten Percent and Double Sum methods, as well as the less conservative methods in Revision 2 of RG 1.92<sup>[16]</sup>.

#### **4.2.2.3.2 High Frequency (Rigid) Modes**

Piping system modes with frequencies greater than the ZPA cutoff frequency are considered as high frequency or rigid range modes. For flexible piping systems, the high frequency response may not be significant since a significant portion of the system mass is excited at frequencies below the ZPA. However, for piping systems, or portions of piping systems, which are more rigidly restrained or have lumped masses near rigid restraints, a significant portion of the system mass may not be accounted for in the low frequency modal analysis. This mass which is not excited at the lower frequencies is termed the "missing mass" of the system. While high frequency modes usually involve small displacement amplitudes and small pipe stresses, they can have a significant impact on support loads.

The response from high frequency modes must be included in the response of the piping system if it results in an increase in the dynamic results of more than 10 percent. Guidance for including the missing mass effects is provided in Appendix A of SRP 3.7.2<sup>[1]</sup>, as well as RG 1.92<sup>[16]</sup>.



The peak modal responses of the system at frequencies above the ZPA are considered to be in phase. Thus, the responses of all high frequency modes are combined by absolute summation.

The U.S. EPR will use the method below for calculating and applying the response of the high frequency modes based on applying a missing mass correction.

The total inertia forces in a system considering a piping system under simple excitation, in a steady-state condition with a unit acceleration applied in a specified direction is mathematically represented by:

$$\{F_t\} = [M]\{r\}$$

Where

- $\{F_t\}$  = Total inertia forces in the specified direction
- $[M]$  = Mass matrix
- $\{r\}$  = Mass point displacement vector produced by a statically applied unit ground displacement

The sum of the inertia forces for all modes included in the modal analysis is calculated as:

$$\{F_s\} = \sum_{n=1}^N \{F_n\} = \sum_{n=1}^N [M]\{\phi_n\}\{\phi_n\}^T [M]\{r\}$$

Where

- $\{F_s\}$  = total inertia force seen by the system in the low frequency modal analysis
- $\{F_n\}$  = inertia force of mode n
- $\{\phi_n\}$  = mode shape
- $N$  = number of modes calculated in the modal analysis

Therefore, the missing, or left out, forces considering a unit ground acceleration in a specified direction are calculated as:

$$\{F_m\} = \{F_t\} - \{F_s\} = [M]\{r\} - \sum_{n=1}^N [M]\{\phi_n\}\{\phi_n\}^T [M]\{r\}$$

Or:

$$\{F_m\} = [M]\{r\} \left[ 1 - \sum_{n=1}^N [M]\{\phi_n\}\{\phi_n\}^T \right]$$

The missing inertia forces are calculated independently for all input components of earthquake motion (i.e., in each direction for each support group). The mode displacements, member end action, and support force corresponding to each missing force vector is determined.

These results are treated as an additional modal result in the response spectra analysis. This missing mass mode is considered to have a modal frequency and acceleration equal to the cut-off frequency used in the modal analysis. These modal results are combined with the low frequency modal results using the methods described in Section 4.2.2.3.1.

#### **4.2.2.4 Directional Combination**

Following the modal combination of results, the responses of the piping system due to each of the three orthogonal earthquake motion inputs are combined. The collinear responses due to each of the input components of motion are combined using the SRSS method. <sup>[16]</sup>

#### **4.2.2.5 Seismic Anchor Motions**

In addition to the dynamic inertia loads, the effects of differential displacements of equipment or structures to which the piping system attaches during a safe shutdown earthquake shall also be considered. The maximum relative displacement for each support location may be obtained from the results of the structural dynamic analysis for the supporting structure or calculated from the applicable floor response.

If the support locations are within a single structure, the seismic displacements are considered to be in-phase and the relative displacement between locations is generally small and may be neglected from the analysis. However, where supports are located within different structures or at flexible equipment connections, the displacements of these locations are conservatively assumed to move 180 degrees out-of-phase and the relative displacements between supported locations must be considered. The analysis of seismic movements at decoupled branch line locations is discussed in Section 5.4.2.

The analysis of these seismic anchor motions (SAMs) will be performed as a static analysis with all dynamic supports active. The results of this analysis shall be combined with the piping system seismic inertia analysis results by absolute summation.

#### **4.2.3 Time History Method**

Seismic analyses may be performed using time history analysis methods in lieu of response spectrum analysis. Time history analysis may also be used for the dynamic analysis of water/steam hammer effects, relief/safety valve thrust loads, jet force loads or other hydraulic transient loadings. The time history analyses of piping systems for the U.S. EPR may be performed using BWSPAN or SUPERPIPE (See Section 5.1 for discussion on computer codes).

The modal superposition method of time history analysis is used for seismic piping analyses with time history seismic input. This method is based on decoupling of the differential equations of motion, considering a linear elastic system. The total response of the system is determined by integrating the decoupled equations for each mode and combining the results of the modes at each time step using algebraic addition.

The mode shapes and frequencies are determined as in the response spectrum analysis. The cutoff frequency for the determination of modal properties is selected to account for the principal vibration modes of the system based upon mass and stiffness properties, modal participation factors and the frequency content of the input forcing function. The missing mass effects of high frequency modes are included based on the same principles described in Section 4.2.2.3.2. Alternatively, the cutoff frequency is

determined such that the number of modes calculated will produce dynamic analysis results within ten percent of the results of the dynamic analysis including the next higher mode.

The time step to be used is to be no larger than one tenth (1/10) of the period of the cutoff frequency.

To account for uncertainties in the structural analysis, one of two methods may be used. Similar to peak shifting in the response spectrum method of analysis, three separate input time histories with modified time steps may be analyzed. Alternatively, the time histories at the attachment points may be derived considering variations in the concrete stiffness.

Damping values are discussed in Section 4.2.5.

Input time histories are analyzed for each of the three mutually orthogonal directions of input motion. The three directional time history inputs are statistically independent and they are applied simultaneously in one analysis. The total response at each time step is calculated as the algebraic sum of the three directional results. Alternatively, the three time histories may be applied individually and the responses combined by the SRSS method.

#### **4.2.4 Equivalent Static Load Method**

An alternate method of analyzing the effects of the SSE on a piping system is to use an equivalent static load method. This simplified analysis considers the mass of piping and components as lumped masses at their center of gravity locations. The seismic response forces due to these masses are then statically determined by multiplication of the contributing mass by an appropriate seismic acceleration coefficient at each location. The seismic acceleration coefficient is determined based on the dynamic properties of the system. When the equivalent static load method is used, justification will be provided that the use of a simplified model is realistic and the results are conservative.

In general, piping systems are multiple degree of freedom systems and have a number of significant modal frequencies in the amplified region of the response spectrum curve (below the ZPA). For these systems, the seismic acceleration coefficient is equal to the peak acceleration of the appropriate floor response spectrum multiplied by 1.5, to account for the multi-modal participation.

This analysis is performed for all three directions of seismic input motion. The results of these three analyses are then combined using the SRSS method, as in the response spectrum analyses. The relative motion of support locations (seismic anchor motions) are considered as in Section 4.2.2.5.

All seismic supports are considered active in this analysis.

#### **4.2.5 Damping Values**

The damping value used in the seismic analysis of the piping system is dependent upon the seismic analysis method used. The damping values used for the SSE dynamic analysis are 2% for piping with a nominal pipe diameter of up to 12 inches and 3% for piping larger than 12 inches. These values are consistent with RG 1.61<sup>[15]</sup> and are used for time history analysis or independent support motion response spectra analysis of piping systems.

For piping systems analyzed using a uniform enveloped response spectra analysis, 5% damping may be used provided that the system is not susceptible to stress corrosion cracking. Five percent damping will not be used for analyzing the dynamic response of piping systems using supports designed to dissipate energy by yielding.

#### **4.3 Inelastic Analysis Methods**

Inelastic analysis will not be used to qualify piping for the U.S. EPR Design Certification.

---

#### **4.4      *Non-Seismic/Seismic Interaction***

The U.S. EPR utilizes state-of-the-art computer modeling tools for design and location of structures, equipment and piping. These same tools are used to minimize the interactions of seismic and non-seismic components, making it possible to protect Seismic Category I piping systems from adverse interactions with non-seismic piping and components. In the design of the U.S. EPR, the primary method of protection for seismic piping is isolation from all non-seismically analyzed piping. In cases where it is not possible, or practical, to isolate the seismic piping, adjacent non-seismic piping is classified as Seismic Category II and analyzed and supported such that an SSE event will not cause an unacceptable interaction with the Seismic Category I piping.

Alternatively, an interaction evaluation may be performed to demonstrate that the interaction will not prevent the Seismic Category I piping system from performing its safety related function.

For non-seismic piping attached to seismic piping, the dynamic effects of the non-seismic piping are accounted for in the modeling of the seismic piping. The attached non-seismic piping up to the analysis boundary is designed to preclude its causing failure of the seismic piping during a seismic event.

##### **4.4.1      *Isolation of Seismic and Non-Seismic Systems***

Isolation of seismic and non-seismic systems is provided by either geographical separation or by the use of physical barriers. Isolation minimizes the interaction effects that must be considered for the seismic systems and minimizes the number of non-seismic systems requiring more rigorous analysis.

Several routing considerations are used to isolate seismic and non-seismic systems. When possible, non-seismic piping is not routed in rooms containing safety-related piping or equipment. Non-seismic piping which cannot be completely separated from seismic systems is routed as far away as possible. To the extent possible, non-seismic systems are not routed above any safety-related components.

#### **4.4.2 Interaction Evaluation**

Non-seismic piping and components may be located in the vicinity of safety-related piping without being qualified as Seismic Category II provided an impact evaluation is performed to verify that no possible adverse impacts will occur. In this evaluation, the non-seismic components are assumed to fall or overturn as a result of a seismic event. Any safety-related piping system or component which may be impacted by the non-seismic component is identified as an interaction target and evaluated to ensure that there is no loss of ability to perform its safety-related function.

The following assumptions and guidelines are used to evaluate non-seismic/seismic interactions:

1. As a result of the seismic event,
  - All non-seismic hangers on the non-seismic piping system are assumed to fail instantaneously.
  - All flanges on bolted connections on the non-seismic piping system are assumed to fail, thus allowing each section of piping to fail independently.
  - Welded non-seismic piping supported by a seismic structure or component is assumed to fail at all rigidly constrained locations. If the non-seismic piping is supported by seismic restraints within the ASME B31.1 Code<sup>[17]</sup> suggested pipe support spacing shown in Table 4-1, it is considered to lose its pressure boundary integrity, but not fall.
2. Following the failure of the non-seismic pipe,
  - All moderate energy piping should be assumed to fall vertically downward from its original position. Side motion should be assumed to be  $\pm 6$  inches (centerline to centerline) from the original pipe position. Pipe whip should be considered for high energy piping.

- Safety-related piping with NPS and thickness equal to or greater than that of the non-seismic piping may be assumed to stop the downward motion of the non-seismic piping without failure of the safety-related piping.



**Table 4-1: Suggested Deadweight Pipe Support Spacing**

Nominal Pipe Size, NPS Inches	Suggested Maximum Span			
	Water Service		Steam, Gas, or Air Service	
	ft	m	ft	m
1	7	2.1	9	2.7
2	10	3.0	13	4.0
3	12	3.7	15	4.6
4	14	4.3	17	5.2
6	17	5.2	21	6.4
8	19	5.8	24	7.3
12	23	7.0	30	9.1
16	27	8.2	35	10.7
20	30	9.1	39	11.9
24	32	9.8	42	12.8

(Reference ASME B31.1 and Subsection NF of the ASME Code)

## **5.0 PIPING MODELING TECHNIQUES**

### **5.1 *Computer Codes***

The following computer programs are used in the analysis of safety-related piping systems.

#### **5.1.1 *SUPERPIPE***

SUPERPIPE is a comprehensive computer program for the structural design and analysis of piping systems. This program is used to analyze piping for both static and dynamic loads and performs design checks for ASME Class 1, 2 and 3 and B31.1 piping.

Static analyses performed by SUPERPIPE include deadweight, distributed loads, thermal, internal pressure and applied forces, moments or displacements. Dynamic analysis methods include both response spectrum analysis and time-history analysis using either modal superposition or direct integration methods.

SUPERPIPE is developed and maintained by AREVA NP. SUPERPIPE has been thoroughly verified and validated to U.S. NRC standards.

#### **5.1.2 *BWSPAN***

BWSPAN is an AREVA NP developed code which performs structural analysis of piping and structural systems. Deadweight, thermal expansion, response spectrum, time history and thermal stratification loading can be analyzed. Output includes displacements, loads, accelerations and displacement time histories, as appropriate. BWSPAN also performs pipe stress and fatigue calculations to a variety of design codes including B31.1, B31.7 and the ASME Code. BWSPAN also calculates stresses for linear type supports according to Subsection NF of the ASME Code.

### **5.1.3 BWHIST**

BWHIST is an AREVA NP developed code which converts pressure time histories generated by CRAFT2 or COMPAR2 into force time histories by integrating the pressure over the area to which it is being applied. BWHIST also orients the resulting force time history for direct input into BWSPAN.

### **5.1.4 BWSPEC**

BWSPEC is an AREVA NP developed code which tabulates displacements, pipe and structure loads, support loads and spring loads for selected locations using output from a BWSPAN analysis. Tabulations can be made for static, response spectrum and time history load cases.

### **5.1.5 COMPAR2**

COMPAR2 is an AREVA NP developed code which performs hydraulics analysis of fluid systems (generally containment cavities). The system is modeled as a series of control volumes and flow paths such that the behavior of a pressure wave caused by a pipe break can be predicted. Pressure time histories can be obtained for any structure included in the model. COMPAR2 is the AREVA NP version of COMPARE-MOD1. There is no difference between these two codes except that COMPAR2 provides an additional output file containing a tabulation of nodal pressures for subsequent use in BWHIST.

### **5.1.6 CRAFT2**

CRAFT2 is an AREVA NP developed code which performs hydraulics analysis of fluid systems (generally piping or components). The system is modeled as a series of control volumes and flow paths such that the behavior of a pressure wave caused by a pipe break can be predicted. Pressure time histories can be obtained at changes in area or changes in flow direction.

**5.1.7 P91232**

P91232 is an AREVA NP developed code which calculates through-wall gradient temperatures and stresses given pipe or nozzle geometry and thermal characteristics (time dependent fluid temperature and film coefficients or flow rates).

**5.1.8 RESPECT**

RESPECT is an AREVA NP code which generates Amplified Response Spectra (ARS) given the frequency and mode characteristics of the system in question (from BWSPAN) and the acceleration time history applicable to the base of the structure. RESPECT is generally used to generate seismic ARS at the branch nozzle locations in a model of a piping system.

**5.2 Dynamic Piping Model**

For dynamic analysis, the piping system is idealized as a three dimensional framework using specialized finite element analysis programs. The analysis model consists of a sequence of nodes connected by beam elements with stiffness properties representing the piping and other inline components. Nodes are typically modeled at points required to define the piping system geometry as well as lumped mass locations, support locations, locations of structural or load discontinuities and at other locations of interest along the piping. System supports are idealized as springs with appropriate stiffness values for the restrained degrees of freedom.

In the dynamic mathematical model, the distributed mass of the system, including pipe, contents and insulation weight, is represented either as a consistent (distributed) mass or as lumped masses placed at each node. For the latter case, in order to adequately determine the dynamic response of the system, elements may be subdivided and additional mass points added. The minimum number of degrees of freedom in the model is to be equal to twice the number of modes with frequencies below the ZPA frequency. Maximum mass point spacing may be no greater than one half of the span length of a simply supported beam with stiffness properties and distributed mass equal

to that of the piping cross-section and a fundamental frequency equal to the cutoff frequency. This maximum span between mass locations is mathematically represented as:

$$S_m = \frac{1}{2} \left( \frac{\pi}{2f_m} \right)^{0.5} \left( \frac{EIg}{w} \right)^{0.25}$$

Where, $S_m$	=	Maximum mass point spacing span
$f_m$	=	Dynamic properties analysis cut-off frequency
$E$	=	Young's Modulus
$I$	=	Moment of Inertia of the pipe
$g$	=	Gravitational Acceleration
$w$	=	Weight of the pipe per unit length

Concentrated weights of in-line components, such as valves, flanges and instrumentation, are also modeled as lumped masses. Torsional effects of eccentric masses are included in the analysis. For rigid components (those with natural frequencies greater than the ZPA cutoff frequency) the lumped mass is modeled at the center of gravity of the component with a rigid link to the pipe centerline. Flexible components (those with natural frequencies less than the ZPA cutoff frequency) are included in the model using beam elements and lumped mass locations to represent the dynamic response of the component.

A portion of the weight of component type supports (such as snubbers, struts, spring hangers, etc.) is supported by the pipe and must be considered in the piping analysis model. The mass contributed by the support is included in the analysis when it is greater than 10 percent of the total mass of the adjacent pipe span (including pipe, contents, insulation and concentrated masses). The adjacent span is defined as the piping including the applicable support and bounded by the adjacent restraint on each

side of this support in each direction. Because the mass of a given support will not contribute to the piping response in the direction of the support, only the unsupported directions need to be considered. A review of the impact of contributing mass of supports on the piping analysis will need to be performed by the COL applicant(s) following the final support design to confirm that the mass of the support is no more than 10% of the mass of the adjacent pipe span..

### **5.3      *Piping Benchmark Program***

Pipe stress and support analysis will be performed by the COL applicant(s). If the COL applicant(s) chooses to use a piping analysis program other than those listed in Section 5.1, the applicant will implement the NRC benchmark program using models specifically selected for the U.S. EPR.

### **5.4      *Model Boundaries***

Piping system analysis models are typically terminated by one of three techniques. These include termination at structural boundaries, termination based on decoupling criteria, or termination by model isolation methods. Structural boundaries and the use of decoupling criteria are the preferred methods. However, after applying these first two methods, further division of the piping system may be desired to create more manageable models for analysis. This may be accomplished using the model isolation methods.

#### **5.4.1    *Structural Boundaries***

The most preferable model boundary is at a rigid structural attachment restraining all six degrees of freedom for the piping, such as at an equipment nozzle or penetration. Structural model boundaries provide isolation of the effects of the piping on one side of the boundary to the piping on the opposite side. For large piping systems, the following types of intermediate structural boundaries may be added to the system during design to allow for further division of the analysis model.

#### **5.4.1.1 *In-line Anchors***

An in-line anchor is a pipe support which restrains the piping in all six degrees of freedom, thereby isolating the piping effects on each side of the support from the other. While an in-line anchor provides a clean model boundary for analysis purposes, it may not be practical in many situations. The addition of in-line anchors generally create stiffer piping systems and may cause significant increases in stress and support loads on lines with high thermal movements. Additionally, the use of in-line anchors on high energy lines adds additional postulated terminal end pipe rupture locations. Therefore, additional in-line anchors are only added if they are determined to be practical.

When in-line pipe anchors are used, anchor load results from seismically analyzed piping on both sides of an anchor are combined to obtain the design loads for the anchor.

#### **5.4.1.2 *Restrained Elbows***

In some instances where a single full anchor support is not feasible, a set of supports placed around an elbow may be used to separate analysis models. In this method, an elbow must be restrained as shown in Figure 5-1. This creates a structurally rigid zone around the elbow in which the piping effects from one end of the restrained section are not transmitted beyond the other end.

The piping within the restraints shown in Figure 5-1 is impacted by the piping on both sides of the restrained elbow. Therefore, the results from both analyses are combined to obtain pipe stresses and hanger loads for the restrained elbow section of the pipe.

#### **5.4.1.3 *Restrained Tees***

A restrained tee is similar to a restrained elbow. The restrained tee is used to divide the branch and run pipe into separate models when the decoupling criteria in Section 5.4.2 are not met. The restraint configuration is shown in Figure 5-2.

The piping within the restraints shown in Figure 5-2 is impacted by both the branch and run pipe. Therefore, the results from both analyses are combined to obtain pipe stresses and hanger loads for the restrained tee section of the pipe.

#### **5.4.2 Decoupling Criteria**

Piping analysis models may be divided by the use of decoupling criteria. Unlike the isolation of effects at the termination point provided by the structural boundary methods, the decoupling criteria provide a model termination point where the effects from one side to the other are limited and can be accounted for using defined methods.

A branch line may be excluded from the analysis model of the run pipe if it is sufficiently small compared to the run pipe, such that the branch has little effect on the results of the run pipe analysis. Generally, branch lines and instrument connections may be decoupled from the analysis model of larger run piping provided that either the ratio of the branch pipe diameter to the run pipe diameter ( $D_b/D_r$ ) is less than or equal to 1/3 or the ratio of the moment of inertia of the two lines ( $I_b/I_r$ ) is less than or equal to 1/25.

The decoupling criteria may also be applied for in-line pipe size changes (such as at a reducer or reducing insert). In this case, the smaller diameter pipe would be treated as the branch line and the larger pipe would be treated as the run.

In addition to the size requirements, a decoupled branch line must be designed to accommodate the thermal and seismic movements of the run pipe without restraint. Therefore, no restraints are to be placed on the branch line near the run pipe connection. Adequate flexibility in the branch line is provided by maintaining a minimum length from the run pipe to the first restraint of 1/2 of the pipe span in Table 4-1 for the branch line. If the branch line design does not meet this requirement, the branch line may not be decoupled from the analysis model of the run piping.

Because the decoupling criteria ensure that the branch line has little effect on the run pipe, only two additional items need to be included in the run pipe analysis. The run pipe analysis must include an appropriate SIF and/or stress indices at the point where



the piping is decoupled. Additionally, mass effects of the branch line shall also be considered. The mass to be considered is the mass of 1/2 of the first span of the branch pipe, including concentrated weights, in each direction.

The branch pipe analysis must include more consideration for the effects of the run piping. The branch point is considered as an anchor in the analysis of the branch pipe with the same SIF and/or stress indices as the run pipe at this point. The movements (displacements and rotations) of run pipe from the thermal, seismic anchor movement (SAM) or pipe break analyses shall be applied as anchor movements with their respective load cases in the branch line analysis. For the SSE inertia load case, each individual run pipe movement shall be analyzed as a separate anchor movement load case on the branch line and combined with its respective load case by absolute summation.

#### **5.4.3 Model Isolation Methods**

The Overlap Region and Influence Zone model isolation methods are used to divide large seismic piping systems that cannot be separated by structural methods or decoupling criteria. These methods are similar in technique in that a section of the piping system is used as the boundary of the models. This section of the system is defined such that the effects of the piping beyond one end of the region do not significantly affect the piping beyond the opposite end of the region. The difference in these methods is in the definition of the qualification boundary as shown in Figure 5-3.

##### **5.4.3.1 Overlap Region Methodology**

An overlap region consists of a section of the piping system that is modeled in two, or more, analyses. This region is defined to be large enough to prevent the transmission of motion due to seismic excitation from one end of the region to the other.

As a minimum, an overlap region must contain at least four (4) seismic restraints in each of three perpendicular directions and at least one change in direction. If a branch is encountered, the balance of restraints required beyond that point shall be included on

all lines joining at the branch. An axial restraint on a straight run of pipe may be counted effective at each point of lateral restraint on that same run.

The overlap region should be selected in a rigid area of the piping system. A dynamic analysis of the overlap region shall be made with pinned boundaries extended beyond the overlap region either to the next actual support or to a span length equal to the largest span length within the region. The fundamental frequency determined from this analysis shall be greater than the frequency corresponding to the ZPA.

When using the overlap methodology, pipe stresses in the overlap region must be qualified separately in each piping model. Supports located in the overlap region, including the ends, are qualified for the enveloped loads and movements resulting from all models covering the overlap region.

#### **5.4.3.2 Influence Zone Modeling**

The main difference between the influence zone and the overlap region is that in using the influence zone, all piping and supports are qualified by a single model. This is achieved by first determining the qualification boundary between models. Each model is then extended to a termination point such that the response of the piping at the termination of the model will not influence the response of the piping within the qualification boundary. The influence zone is then defined by the section of piping between the qualification boundary and the model termination point.

Because the response of the piping at and beyond the termination point will not, by definition, influence the piping within the qualification region, the pipe stresses and supports are qualified by the results of one analysis only. However, when using this methodology versus the overlap region, a significantly larger section of piping may be required to be included in two or more models.

---

## **5.5 Seismic/Non-Seismic Interface Boundaries**

The effects of non-seismic piping connected to Seismic Category I piping must either be isolated from the Seismic Category I piping or included in the analysis model. The model boundary at a non-seismic/ seismic piping interface may consist of structural isolation, decoupling or model isolation methods similar to those discussed in 5.4. However, additional considerations are required to ensure that the dynamic effects of the non-seismic piping are considered.

Seismic Category I design requirements extend to the first seismic restraint beyond the seismic system boundary. The non-seismic piping and supports beyond this location that impact the dynamic analysis of the Seismic Category I piping are reclassified as Seismic Category II and included in the model. The extent of piping classified as Seismic Category II may be bounded by the following methods.

- Any of the structural boundaries in Section 5.4.1 may be used to terminate the Seismic Category II region. In these cases, all piping and supports between the Seismic Category I design boundary and the structural anchor, or the final restraint of a restrained elbow or tee, are classified as Seismic Category II.
- Locations in the seismic/non-seismic interface region which meet the decoupling criteria in Section 5.4.2 are acceptable model boundaries. When this method is applied, all piping and restraints beyond the Seismic Category I boundary up to the decoupled location are classified as Seismic Category II.
- Alternatively, a series of piping restraints may be utilized to isolate the seismic response of non-seismically designed piping from seismically designed piping, similar to the model isolation methods discussed in Section 5.4.3. In this case, isolation of dynamic effects is provided by three seismic restraints in each of the three orthogonal directions beyond the Seismic Category I design boundary.

In all cases, the Seismic Category II portion of the system is analyzed with the Seismic Category I piping for the SSE load case as well as loads resulting from the potential

---

failure of the non-seismic piping and pipe supports. This is accomplished by the application of a plastic moment in each of three orthogonal directions at the termination of the model. Each moment is applied and evaluated in a separate analysis and the results of the three analyses are enveloped.

**Figure 5-1: Restrained Elbow**

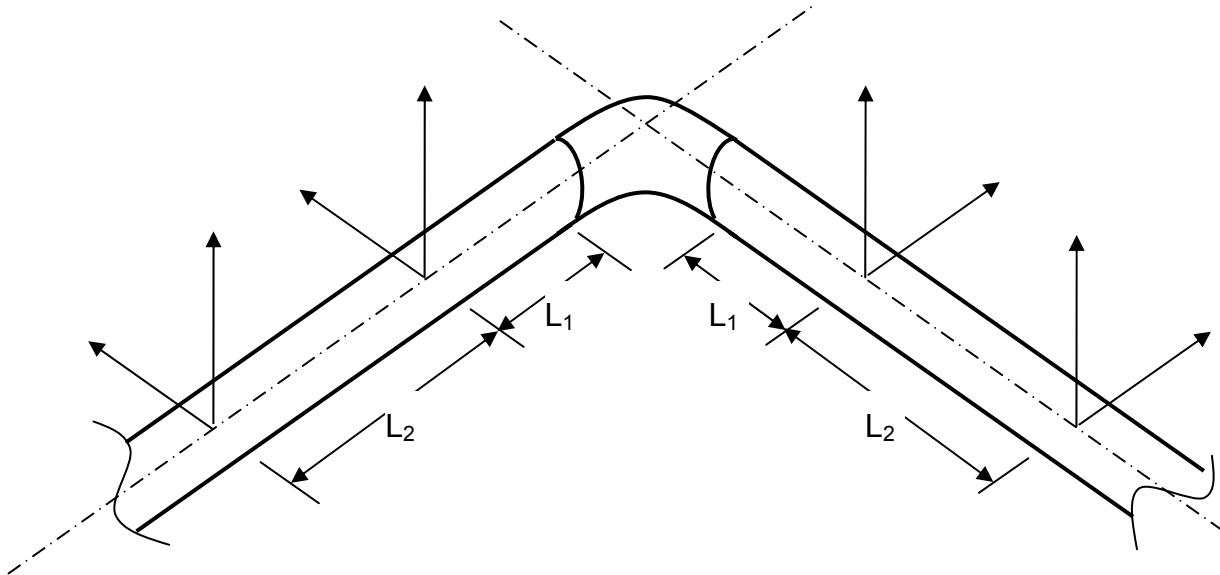

Where L is equal to the recommended support span per Table 4-1 and  $L_1$  and  $L_2$  are defined as follows:

Dimension	Nominal	Minimum	Maximum
$L_1$	6"	Fitting Weld Clearance	6"
$L_2$	$L/4$	$L/8$	$L/4$

**Figure 5-2: Restrained Tee**

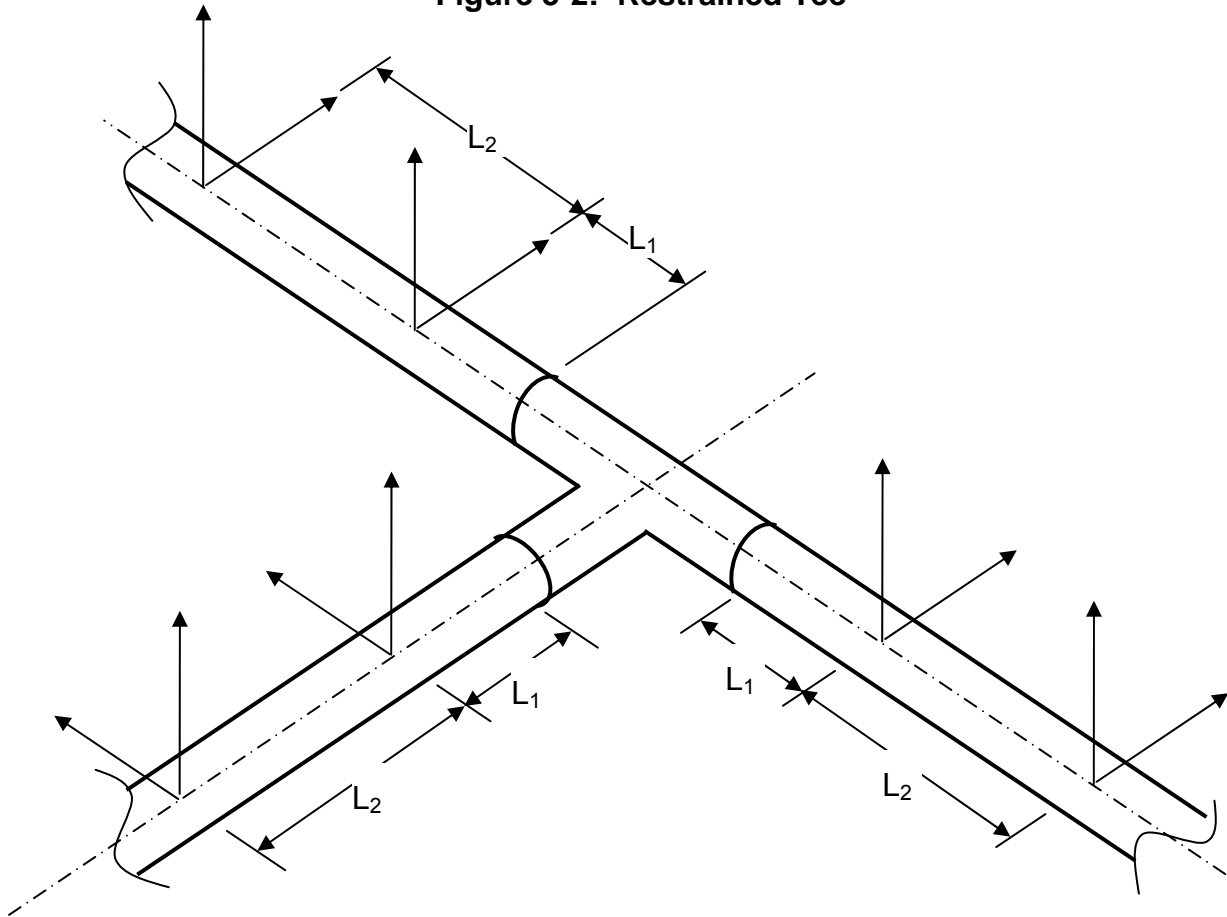

Where L is equal to the recommended support span per Table 4-1 and  $L_1$  and  $L_2$  are defined as follows:

Dimension	Nominal	Minimum	Maximum
$L_1$	6"	Fitting Weld Clearance	6"
$L_2$	$L/4$	$L/8$	$L/4$

**Figure 5-3: Model Isolation Methods of Division**

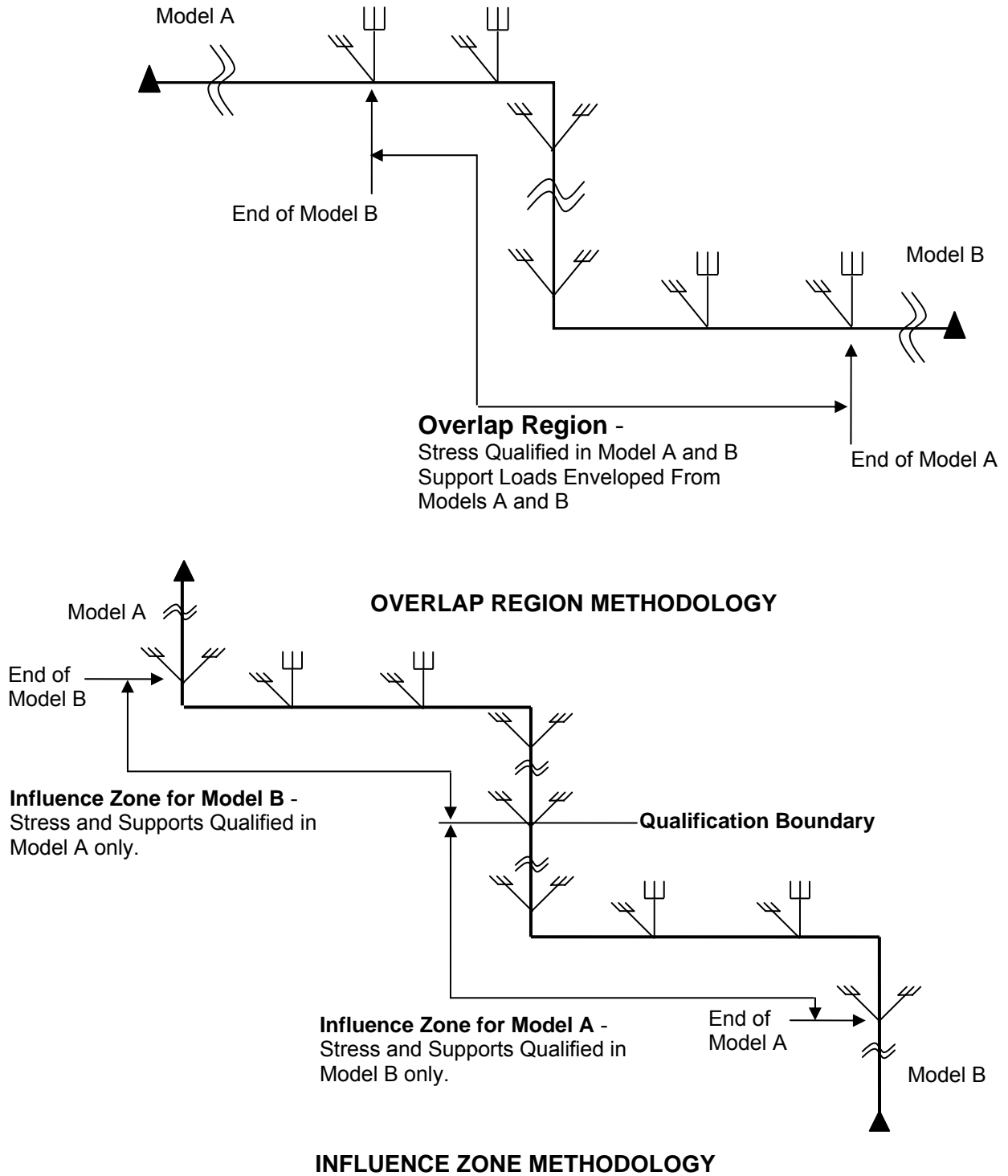

## 6.0 PIPE SUPPORT DESIGN CRITERIA

Pipe supports are designed for the loading, deflections and directionality of support required by the piping analysis, in order to provide for the proper functionality requirements of the piping itself. In addition, the pipe support elements must be designed to meet the requirements of the appropriate design codes, to again be consistent with the code requirements of the overall piping system. Pipe supports typically include structural elements, at times also coupled with standard manufactured catalog items developed specifically for pipe support usage.

The piping analysis usually makes idealized supporting assumptions as required by the specific analysis conditions. In turn, the supports are typically designed separately from the piping analysis, with design methods to match the assumed analysis constraints. As such, the supports should be designed to minimize their effects on the piping analysis, and must not invalidate the piping analysis assumptions.

### 6.1 *Applicable Codes*

The design codes for U.S. EPR piping supports are designated based on the seismic category of the support in question. Seismic Category I pipe supports shall be designed in accordance with Subsection NF of the ASME Code for Service Levels A, B and C<sup>[2]</sup>. For Service Level D, Appendix F of Section III of the ASME Code will be utilized. Subsection NF details varying requirements for ASME Class 1, 2 and 3 support structures, and is further delineated into plate and shell type supports, linear type supports and standard piping supports. In addition, the welding requirements for A500, Grade B tube steel from AWS D1.1 are utilized<sup>[18]</sup>.

Plate and shell type supports, as defined in the ASME Code are supports such as skirts or saddles fabricated from plate elements and loaded to create a biaxial stress field. Linear type supports are essentially subjected to a single component of direct stress, but may also be subjected to shear stresses. Examples of linear type support elements would be beams, columns, frames and rings. Standard supports are made from typical support catalog items such as springs, rigid struts and snubbers. Standard support



items are typically load rated items, but may be also qualified by plate and shell or linear analysis methods.

Seismic Category II pipe supports are designed to ANSI/AISC N690, "Specification for the Design, Fabrication and Erection of Steel Safety-Related Structures for Nuclear Facilities" <sup>[19]</sup>.

Non-Seismic Category pipe supports are designed using guidance from the AISC Manual of Steel Construction <sup>[20]</sup>.

In addition to the pipe support design codes mentioned above, expansion anchors and other steel embedments in concrete shall be designed for concrete strength in accordance with ACI-349, "Code Requirements for Nuclear Safety Related Concrete Structures" <sup>[21]</sup>.

## **6.2 Jurisdictional Boundaries**

The jurisdictional boundaries for pipe supports fall into two categories. The first boundary is between the pipe and the support structure. The second boundary is between the support structure and the associated building structure. For the U.S. EPR, the pipe support jurisdictional boundaries will be as defined in the ASME Code.

The jurisdictional boundary between the pipe and its support structure will follow the guidance of Subsections NB-1132, NC-1132, or ND-1132, as appropriate for the ASME Class of piping involved. For piping analyzed to B31.1, the jurisdictional boundary guidance of ND-1132 will be utilized. In general, for attachments to the pipe which are not directly welded to the pipe, the jurisdictional boundary is at the outer surface of the pipe. For attachments which are welded directly to the pipe, the boundary will vary in accordance with the configuration of the attachment. For such welded attachments, the guidance in Subsections NB-1132, NC-1132 or ND-1132 will be utilized. In addition, local pipe stresses due to the welded attachments will be evaluated in accordance with the appropriate ASME Code Cases given in Section 2.2 of this document.

The jurisdictional boundary between the pipe support and the building structure will follow the guidance of Subsection NF-1130 of the ASME Code. In general, for attachments to building steel, the boundary is taken at the interface with the building steel, with the weld being designed to the rules of NF. For attachments to concrete building structures, the boundary is generally at the weld of the support member to a baseplate or embedded plate, with the weld again being designed to the rules of NF.

### **6.3      *Loads and Load Combinations***

Load combinations for the U.S. EPR will be defined based on the four Service Levels used in the ASME Code; Levels A, B, C and D. These four level designations are defined in Section 3.2. Based on the guidance given in SRP 3.9.3<sup>[1]</sup>, loading combinations of the various potential analysis load cases will be developed for the four defined levels.

Note that the load combinations used for all four levels will always include the normal plant operating loadings in effect for all conditions, i.e., deadweight and thermal. However, since signed thermal loadings may cancel other signed loadings, the cold condition must also always be considered for support loads.

The following sections (except Section 6.3.11) provide an explanation of the various analysis load cases used in the load combinations, and Table 6-1 provides the specific load combinations for pipe supports. The acceptance criteria associated with the Service Levels will be per ASME Code, Subsection NF, ANSI/AISC N690 or the AISC Manual of Steel Construction, as appropriate. Section 6.3.11 provides minimum design loads for pipe support design when the actual calculated design loads are very small. The symbol designations in parentheses in the section titles are used in the table to represent the corresponding loadings.

#### **6.3.1      *Deadweight (D) Loads***

Deadweight loads for a pipe support are usually based on the deadweight load case of the associated piping analysis, and include the weight of the pipe and fittings, contents,

insulation, and pipe support components directly supported by the pipe, such as clamps for spring supports (See Section 5.2 for specific details). In addition to gravity loads from the piping analysis, the deadweight of the support itself should be considered in the support qualification, if considered significant.

Note that gravity supports are either designed to be rigid or flexible supports based on the piping analysis thermal movements of the pipe. High thermal movements often require a flexible spring support to allow thermal growth while still supporting the pipe under the deadweight condition.

### **6.3.2 Thermal ( $T_N$ , $T_U$ , $T_E$ , $T_F$ ) Loads**

Thermal loads for a pipe support will usually be calculated in one or more load cases in the associated piping analysis based on the thermal operating parameters of the piping system. Since there may be differing temperatures of the piping fluid for the various service levels, the subscripts of the symbol designations above represent the four service levels; normal, upset, emergency and faulted. The various temperatures in the piping system will cause the overall system to expand or contract, thereby applying loads to the pipe supports which are restricting the free expansion or contraction. In addition, anchor points for the piping system, such as equipment nozzles or branch connections, may also be moving thermally such that they apply thermal movements to the piping analysis. These are typically referred to as Thermal Anchor Movements (TAMs), which must also be considered in the overall piping analysis.

Along with the overall system effects mentioned above, consideration for local, radial thermal expansion of the pipe cross section must be made. This effect is often addressed by having small gaps around the pipe for such thermal growth, while still maintaining relatively tight constraints for seismic loadings (See Section 6.11).

One further consideration for the pipe support design is the environmental condition around the pipe support, including the pipe temperature. The air temperature around the support may cause expansion of the support structure itself, as well as affect the material properties of the support structure. In addition, an elevated pipe temperature

may cause the support structure to undergo local expansion, or be subject to reduced material allowables near the vicinity of the pipe.

### **6.3.3 Friction ( $F$ ) Loads**

Friction loads to be applied to the pipe support are typically not calculated in the piping analysis, but instead are hand calculated during the support design. Such loads are developed when sliding of the pipe across the surface of a support member in the unrestrained direction(s) occurs under thermal expansion conditions. See Section 6.10 for further discussion of the development of these loads.

### **6.3.4 System Operating Transient ( $R_{SOT}$ ) Loads**

System operating transients are defined in SRP 3.9.3<sup>[1]</sup> as “the transients and their resulting mechanical responses due to dynamic occurrences caused by plant or system operation.” These dynamic loads will typically come from load cases analyzed in the computerized piping analysis, and are the result of transients such as safety/relief valve thrust, fast valve closure, water hammer and steam hammer.

### **6.3.5 Wind ( $W$ ) Loads**

Exposed piping and support structures will be analyzed for the design basis wind forces. This will typically be the result of a load case in the piping analysis performed for the piping system. Depending on the speed of application of the wind loading, snubber supports may or may not activate. Conservatively, both a static support and dynamic support configuration will be analyzed and the results enveloped.

### **6.3.6 Tornado ( $W_T$ ) Loads**

As is done for the wind loads above, exposed piping will also be analyzed for the design basis tornado. The tornado loads will consist of loads due to tornado wind speeds, differential pressures and tornado generated missiles, as appropriate. The tornado wind speeds are calculated from the translational velocity of the tornado added to the rotational velocity. As for the wind loadings, the support loads will typically be the result

of a load case in the piping analysis and both a static support and dynamic support configuration will be analyzed and the results enveloped for the tornado wind loads. Missile loadings will be considered as a dynamic load case for support activation purposes.

### **6.3.7 Design Basis Pipe Break ( $R_{DBPB}$ ) Loads**

Design basis pipe breaks are defined in SRP 3.9.3<sup>[1]</sup> as “those postulated pipe breaks other than a LOCA or MS/FWPB. This includes postulated pipe breaks in Class 1 branch lines that result in the loss of reactor coolant at a rate less than or equal to the capability of the reactor coolant makeup system”. These loads would include loads applied to the piping from another nearby broken pipe (jet impingement or pipe whip), or loads in a pipe from a break in the same pipe (dynamic effects in the system due to the break).

### **6.3.8 Main Steam / Feedwater Pipe Break ( $R_{MS/FWPB}$ ) Loads**

These pipe break loads are the same type of loadings, determined in the same fashion as for the design basis pipe break, except that they are specifically for the two subject systems.

### **6.3.9 Loss of Coolant Accident (LOCA) Loads**

Loss of coolant accidents are defined in Appendix A to 10 CFR Part 50 as “those postulated accidents that result from the loss of reactor coolant, at a rate in excess of the capability of the reactor coolant makeup system, from breaks in the reactor coolant pressure boundary, up to and including a break equivalent in size to the double-ended rupture of the largest pipe of the Reactor Coolant System.” Leak-before-Break methodology will be used to eliminate double ended guillotine breaks in the RCL and Pressurizer Surge Line piping, but breaks in the smaller attached lines will be considered. Again, these loads would be determined in the same fashion as for the other pipe break scenarios.

### **6.3.10 Safe Shutdown Earthquake (SSE) Loads**

The seismic loads to be applied to the pipe supports from the piping, due to the maximum potential earthquake expected in the area of the plant, are the SSE loads. These loads will include inertial loads from the piping, as well as seismic movements at anchor points such as piping anchor supports, equipment nozzles and branch line points.

In addition to the SSE loads from the piping, the seismic acceleration of the support structure itself must also be considered. This effect is called self-weight excitation, and is discussed further in Section 6.8.

### **6.3.11 Minimum Design Loads**

Minimum design loads will be defined for all pipe supports such that uniformity is obtained in the load carrying capability of the supports. As such, all supports should be designed for the largest of the following three loads:

- 100% of the Level A condition load.
- The weight of a standard ASME B31.1 span of water filled, schedule 80 pipe.
- Minimum value of 150 pounds.

## **6.4 Pipe Support Baseplate and Anchor Bolt Design**

Although the use of baseplates with expansion anchors is expected to be minimized in the U.S. EPR design, there will likely be some instances where baseplate designs must be utilized. For such designs, the concrete will be evaluated using ACI-349<sup>[21]</sup>, Appendix B subject to the conditions and limitations of RG 1.199<sup>[22]</sup>. This guidance accounts for the proper consideration of anchor bolt spacing and distance to a free edge of concrete. In addition, all aspects of the anchor bolt design, including baseplate flexibility and factors of safety will be utilized in the development of anchor bolt loads, as addressed in IE Bulletin 79-02, Revision 2<sup>[23]</sup>.

---

## **6.5      *Use of Energy Absorbers and Limit Stops***

The use of energy absorbers for pipe supports utilizing normal design loadings is not expected for the U.S. EPR design, but energy absorbing material may be used in the design of pipe whip restraints. The use of gapped rigid supports (limit stops) is not anticipated in the U.S. EPR design.

## **6.6      *Use of Snubbers***

Snubber supports for piping systems are utilized for situations requiring free thermal movements, while restraining movements due to dynamic loadings. An example of such a situation would be the need to relieve dynamic stresses at a piping fitting, while allowing thermal growth of the pipe, thereby minimizing the thermal loads/stresses at the same fitting. Many times this approach is used for the first support on piping adjacent to an equipment nozzle. Due to the rigidity of an equipment nozzle (usually modeled as a rigid piping anchor), care should be taken in the support design to assure that the pipe will have the required dynamic acceleration/movement to properly activate the snubber. Typical snubber components are manufactured standard hardware, and may be either hydraulic or mechanical in operation.

The size and location of snubbers in a piping system will be a function of the thermal and dynamic analyses requirements. Snubbers, in general should not be used where thermal movements are small. Also, use of snubbers should be minimized as much as reasonable due to the maintenance and testing requirements for these components. As such, accessibility of any snubbers utilized must also be a consideration in the design of the piping system.

Other design/analysis considerations for snubbers are related to the ability of the snubbers to properly activate for their design loadings. For snubbers which might experience high thermal growth rates, the analysis should ensure that such growth rates do not exceed the snubber lock-up velocity. Also, for parallel snubbers utilized in the same support, care must be taken to ensure that total fitting clearances are not mismatched between the tandem snubbers such that one will activate before the other.

Other such load sharing considerations for tandem snubbers, such as significant stiffness differences, must also be a support design criterion.

The Design Specification(s) provided to the supplier(s) of snubbers should contain the following types of information:

- Applicable Codes and Standards
- Functional Requirements
- Operating Environment (Both Normal and Post Accident)
- Materials (Construction and Maintenance)
- Functional Testing and Certification
- Requirement for Construction to Meet ASME Code, Subsection NF

The proper installation and operation of snubbers will be verified by the COL applicant, utilizing visual inspections, hot and cold position measurements, and observance of thermal movements during plant startup.

### **6.7      *Pipe Support Stiffnesses***

Supports in the piping analysis model may be modeled with either the actual stiffness of the support structure, or an arbitrarily rigid stiffness. In general, rigid stiffnesses will be utilized for the piping supports, with a check on support deflection in the restrained direction(s) to verify the rigidity. The actual stiffness will be modeled for variable spring supports. If actual support stiffnesses are utilized for other than spring supports, the support should be designed such that the stiffness is approximately the same for both directions along a single axis. If the actual support stiffness is used for any support other than variable spring supports, all supports within the piping model shall use the actual support stiffnesses. Also, caution should be used in the support design to keep the unrestrained direction of the support from having a frequency which would tend to provide significant amplification of the support structure mass.



Two deflection checks will be performed for each support modeled as rigid in the piping analysis. The first check will compare the deflection in the restrained direction(s) to a maximum of 1/16 inch for SSE loadings or the minimum support design loadings of Section 6.3.11. The second check will compare the deflection in the restrained direction(s) to a maximum of 1/8 inch for the worst case deflection for any load case combination. Note that in the development of the support deflections, dynamically flexible building elements beyond the support jurisdictional boundaries will also be considered.

### **6.8      *Seismic Self-Weight Excitation***

The response of the support structure itself to SSE loadings is to be included in the pipe support analysis. In general, the inertial response of the support mass will be evaluated using a response spectrum analysis similar to that performed for the piping. Damping values for welded and bolted structures are given in RG 1.61 <sup>[15]</sup>. This support self-weight SSE response, the piping inertial load SSE response and the SSE loads from SAM are to be combined by absolute sum.

### **6.9      *Design of Supplemental Steel***

As discussed in Section 6.1, all Seismic Category I and II pipe supports for the U.S. EPR will be designed to Subsection NF of the ASME Code or to ANSI/AISC N690, respectively. This will include any supplemental steel required to connect the main support structure to the building structure. As is also discussed in Section 6.2, the jurisdictional boundaries of the support structures to the building structures will likewise follow the guidance of Subsection NF. This guidance would include any such supplemental steel within the support boundary. Thus, the supplemental steel will be designed to Subsection NF of the ASME Code or ANSI/AISC N690 for Seismic Category I and II pipe supports, respectively. For non-seismic pipe supports, the AISC Manual of Steel Construction will be utilized for the supplemental steel, as it will for the main support structure.

---

**6.10      *Consideration of Friction Forces***

As discussed in Section 6.3.3, friction forces develop in the pipe support when sliding of the pipe across the surface of a support member in the unrestrained direction(s) occurs under thermal expansion conditions. Since friction is due to the gradual movement of the pipe, loads from friction will only be calculated using the deadweight and thermal loads normal to the applicable support member. Friction due to other piping loads will not be considered.

Specifically, to calculate the friction forces, a force will only need to be calculated if the thermal movement in the applicable unrestrained direction(s) is greater than 1/16 inch. If this threshold is met, the force will be calculated using the product of  $CN$ , where  $C$  is the appropriate coefficient of friction and  $N$  is the total force normal to the movement. The coefficient of friction will be taken as 0.3 for steel-to-steel conditions and 0.1 for low friction slide/bearing plates. If support stiffness information is readily available, this calculated force can be reduced by using the force of  $KX$  (if less than  $CN$ ), where  $K$  is the support stiffness in the movement direction and  $X$  is the movement.

**6.11      *Pipe Support Gaps and Clearances***

For rigid guide pipe supports modeled as rigid restraints in the piping analysis, the typical industry design practice is to provide small gaps between the pipe and its surrounding structural members. These small gaps allow radial thermal expansion of the pipe, as well as allow rotation of the pipe at the support. Excessive gaps in these supports would lead to a non-linear condition, which will not be the normal design for the U.S. EPR, as stated in Section 6.5. The normal design practice for the U.S. EPR will be to use a nominal cold condition gap of 1/16 inch on each side of the pipe in the restrained direction. This will lead to a maximum total cold condition gap around the pipe for a particular direction of 1/8 inch.

For gaps around the pipe in an unrestrained direction, the gap magnitudes should be specified large enough to accommodate the maximum movement of the pipe.

---

**6.12 Instrumentation Line Support Criteria**

The design and analysis loadings, load combinations and acceptance criteria to be used for instrumentation line supports will be similar to those used for pipe supports. The applicable design loads will include deadweight, thermal expansion and seismic loadings (where appropriate). The applicable loading combinations will similarly follow those used for Normal and Faulted Levels in Table 6-1, utilizing the design loadings mentioned above. The acceptance criteria will be from ASME Code, Subsection NF for Seismic Category I instrumentation lines, ANSI/AISC N690 for Seismic Category II instrumentation lines and the AISC Manual of Steel Construction for non-seismic instrumentation lines.

**6.13 Pipe Deflection Limits**

For pipe supports utilizing standard manufactured hardware components, the manufacturer's recommendations for limitations in its hardware will be followed. Examples of these limitations are travel limits for spring hangers, stroke limits for snubbers, swing angles for rods, struts and snubbers, alignment angles between clamps or end brackets with their associated struts and snubbers, and the variability check for variable spring supports. In addition to the manufacturer's recommended limits, allowances will be made in the initial designs for tolerances on such limits. This is especially important for snubber and spring design where the function of the support can be changed by an exceeded limit.

**Table 6-1: Loading Combinations for Piping Supports**

Condition	Load Combination <sup>(1), (2), (3)</sup>
Normal (Level A)	$D + T_N + F$
Upset (Level B)	$D + T_U + R_{SOT}$ $D + T_U + W$
Emergency (Level C)	$D + T_E + R_{SOT}$ $D + T_E + W_T$ $D + T_E + R_{DBPB}$
Faulted (Level D)	$D + T_F + R_{SOT}$ $D + T_F + R_{DBPB}$ $D + T_F + R_{MS/FWPB}$ $D + T_F + LOCA$ $D + T_F + SRSS (R_{DBPB} + SSE)$ $D + T_F + SRSS (R_{MS/FWPB} + SSE)$ $D + T_F + SRSS (LOCA + SSE)$

## Notes:

1. OBE inertia and SAM loads are not included in the design of Class 2 & 3 piping<sup>[7]</sup>
2. The acceptance criteria for the load combinations are discussed in Section 6.3.
3. SSE includes inertia and SAM loads combined by absolute sum.

## **7.0 SUMMARY/CONCLUSIONS**

The piping analysis and support design for the U.S. EPR adheres to the requirements of Title 10 of the Code of Federal Regulations and the ASME Code. This is accomplished by utilizing industry guidance in NUREGs, Regulatory Guides, and NRC and industry bulletins. These codes and standards, acceptance criteria and modeling techniques are generally the same as those used in existing plant designs updated only as a result of industry experiences and increased knowledge.

Adhering to the guidance provided by this topical for piping analysis and support design will result in these structures and components in the U.S. EPR being designed to industry requirements while providing adequate levels of safety to the public.

## 8.0 REFERENCES

1. NUREG-0800, "Standard Review Plan for the Review of Safety Analysis Reports for Nuclear Power Plants," Draft Revision 3.
2. ASME Boiler & Pressure Vessel Code, Section III, Division 1, 2001 Edition through 2003 addenda.
3. ASME Boiler & Pressure Vessel Code, Section III, Division 1, 1992 Edition through 1993 addenda.
4. Regulatory Guide 1.84, "Design, Fabrication and Materials Code Case Acceptability, ASME Section III," Revision 33.
5. Regulatory Guide 1.29, "Seismic Design Classification," Revision 3.
6. WRC Bulletin 353, "Position Paper on Nuclear Plant Pipe Supports," May 1990.
7. SECY-93-087, "Policy, Technical, and Licensing Issues Pertaining to Evolutionary and Advanced Light-Water (ALWR) Designs," July 21, 1993.
8. IEEE 344-1987, "Recommended Practice for Seismic Qualification of Class 1E Equipment for Nuclear Power Generating Stations."
9. NUREG-1367, "Functional Capability of Piping Systems," November 1992.
10. NRC Bulletin 79-13, "Cracking in Feedwater System Piping," Revision 2.
11. NRC Bulletin 88-11, "Pressurizer Surge Line Thermal Stratification."
12. NRC Bulletin 88-08, with Supplement 3, "Thermal Stresses in Piping Connected to Reactor Coolant System."
13. Regulatory Guide 1.122, "Development of Floor Design Response Spectra for Seismic Design of Floor-Supported Equipment or Components," Revision 1.
14. WRC Bulletin 300, "Technical Position on Criteria Establishment; Technical Position on Damping Values for Piping - Interim Summary Report; Technical Position on Response Spectra Broadening; Technical Position on Industry Practice," December 1984.
15. Regulatory Guide 1.61, "Damping Values for Seismic Design of Nuclear Power Plants," October 1973.
16. Regulatory Guide 1.92, "Combining Modal Responses and Spatial Components in Seismic Response Analysis," Revision 2.
17. ASME B31.1, "Power Piping," 2004 Edition.

18. AWS D1.1/D1.1M:2004, "Structural Welding Code - Steel."
19. ANSI/AISC N690-1994, "Specification for the Design, Fabrication and Erection of Steel Safety-Related Structures for Nuclear Facilities."
20. AISC Manual of Steel Construction, 9th Edition.
21. ACI-349-2005, Appendix B, "Code Requirements for Nuclear Safety Related Concrete Structures."
22. Regulatory Guide 1.199, "Anchoring Components and Structural Supports in Concrete," November 2003.
23. NRC Bulletin 79-02, "Pipe Support Base Plate Designs Using Concrete Expansion Anchor Bolts," Revision 2.