



Westinghouse Electric Company
Nuclear Power Plants
P.O. Box 355
Pittsburgh, Pennsylvania 15230-0355
USA

U.S. Nuclear Regulatory Commission
ATTENTION: Document Control Desk
Washington, D.C. 20555

Direct tel: 412-374-6306
Direct fax: 412-374-5456
e-mail: sterdia@westinghouse.com

Your ref: Project Number 740
Our ref: DCP/NRC1777

September 15, 2006

Subject: AP1000 COL Response to Requests for Additional Information (TR #37)

In support of Combined License application pre-application activities, Westinghouse is submitting a response to the NRC request for additional information (RAI) on AP1000 Standard Combined License Technical Report 37, APP-GW-GLN-003, Hydrogen Igniter Locations. This RAI response is submitted as part of the NuStart Bellefonte COL Project (NRC Project Number 740). The information included in the response is generic and is expected to apply to all COL applications referencing the AP1000 Design Certification.

A response is provided for TR37-1, transmitted in an NRC letter from Steven D. Bloom to Andrea Sterdis, dated August 7, 2006, Subject: Westinghouse AP1000 Combined License (COL) Pre-application Technical Report 37 – Request for Additional Information (TAC No. MD1433).

Pursuant to 10 CFR 50.30(b), the response to the request for additional information on Technical Report 37, numbered RAI-TR37-001 is submitted as Enclosure 1 under the attached Oath of Affirmation.

It is expected that when the RAI on Technical Report 37 is complete, the technical report will be revised as indicated in the response and submitted to the NRC. The RAI response will be included in the document.

Questions or requests for additional information related to the content and preparation of these responses should be directed to Westinghouse. Please send copies of such questions or requests to the prospective applicants for combined licenses referencing the AP1000 Design Certification. A representative for each applicant is included on the cc: list of this letter.

Very truly yours,

A handwritten signature in black ink that reads "D. F. Hutchings for". The signature is written in a cursive style.

A. Sterdis, Manager
Licensing and Customer Interface
Regulatory Affairs and Standardization

/Attachment

1. "Oath of Affirmation," dated September 15, 2006

/Enclosure

1. Response to Request for Additional Information on Technical Report No. 37
RAI-TR37-001

cc:	S. Bloom	- U.S. NRC	1E	1A
	S. Coffin	- U.S. NRC	1E	1A
	G. Curtis	- TVA	1E	1A
	P. Grendys	- Westinghouse	1E	1A
	P. Hastings	- Duke Power	1E	1A
	C. Ionescu	- Progress Energy	1E	1A
	D. Lindgren	- Westinghouse	1E	1A
	A. Monroe	- SCANA	1E	1A
	M. Moran	- Florida Power & Light	1E	1A
	C. Pierce	- Southern Company	1E	1A
	E. Schmiech	- Westinghouse	1E	1A
	G. Zinke	- NuStart/Entergy	1E	1A

ATTACHMENT 1

“Oath of Affirmation”

ATTACHMENT 1

UNITED STATES OF AMERICA
NUCLEAR REGULATORY COMMISSION

In the Matter of:)
NuStart Bellefonte COL Project)
NRC Project Number 740)

APPLICATION FOR REVIEW OF
"AP1000 GENERAL COMBINED LICENSE INFORMATION"
FOR COL APPLICATION PRE-APPLICATION REVIEW

Daniel S. Lipman, being duly sworn, states that he is Senior Vice President, Nuclear Power Plants, for Westinghouse Electric Company; that he is authorized on the part of said company to sign and file with the Nuclear Regulatory Commission this document; that all statements made and matters set forth therein are true and correct to the best of his knowledge, information and belief.



Daniel S. Lipman
Senior Vice President
Nuclear Power Plants

Subscribed and sworn to
before me this 15th day
of September 2006.

COMMONWEALTH OF PENNSYLVANIA
Notarial Seal
Debra McCarthy, Notary Public
Monroeville Boro, Allegheny County
My Commission Expires Aug. 31, 2009
Member, Pennsylvania Association of Notaries

Notary Public

ENCLOSURE 1

Response to Request for Additional Information on Technical Report No. 37

RAI-TR37-001

AP1000 TECHNICAL REPORT REVIEW

Response to Request For Additional Information

RAI Number: RAI-TR37-001

Question:

Westinghouse is modifying the elevations or locations of certain hydrogen igniters within the AP1000 hydrogen control system. Westinghouse declares that these modifications must be made because either the polar crane elevation has been changed, to place the igniters in locations where they are more easily accessible, or to avoid trip hazards. Westinghouse states that changing the elevation or location of the identified hydrogen igniters does not alter their design function and has no effect on analysis or analysis method. Provide justification of why the proposed changes do not affect the analysis and how the proposed changes do not affect the performance or controls of hydrogen control functions.

Westinghouse Response:

DCD Section 6.2.4.2.3 provides a description of the AP1000 hydrogen ignition subsystem. Table 6.2.4-6 provides a discussion of the criteria used for AP1000 igniter placement and a discussion of the igniter placement implementation. Table 6.2.4-7 provides a summary of the igniter locations and elevations.

The staff assessment of the AP1000 hydrogen ignition subsystem design was provided in Section 6.2.5.1 of NUREG-1793, Final Safety Evaluation Report for AP1000 Design (September 2004). As stated in the excerpts from paragraphs 3 and 9 of this FSER section, adequate igniter coverage is provided based on implementation of the igniter location criteria in DCD Table 6.2.4-6:

DCD Tier 2, Table 6.2.4-6, provides the criteria used in the evaluation and the application of the criteria to specific compartments. [paragraph 3]

On the basis of the staff's review and Westinghouse's implementation of the igniter location criteria as listed in DCD Tier 2, Table 6.2.4-6 the staff concludes that adequate igniter coverage has been provided. [paragraph 9]

Therefore, changes in the placement of the hydrogen igniters that are consistent with the criteria in Table 6.2.4-6 do not alter the design function of the igniters, have no effect on any analysis or analysis method, and do not affect the performance or controls of hydrogen control functions.

a) Section II, Technical Description and Justification, of Technical Report 37, Hydrogen Igniter Locations (APP-GW-GLN-003) will be revised as shown below to indicate that the same location criteria used for design certification review of the hydrogen igniter subsystem are being followed for identified changes to igniter locations as a result of any continuing COL and/or detailed

AP1000 TECHNICAL REPORT REVIEW

Response to Request For Additional Information

design activities for the AP1000. These criteria are applicable to the igniter location changes identified in both TR37 and in TR36, AP1000 Pressurizer Design (APP-GW-GLR-016).

b) TR37 will be updated to indicate that the pressurizer design change was another reason for igniter location changes, to be consistent with TR36.

c) Section III, DCD Mark-Up, of TR37 will be updated to reflect the latest igniter #40 and #43 elevation changes identified in TR36 for DCD Figures 6.2.4-5, 6.2.4-11, and 6.2.4-13 that were superseded by TR36 changes. The igniter elevation changes in these three TR36 figures were approved and submitted to the NRC after TR37 was submitted, so they correctly supersede the TR37 version of these figures.

(TR 36 also identified that there was an inconsistency in the original elevation of igniter #40 in DCD Figure 6.2.4-5 that was shown to be 175'8" while the correct original elevation was shown in DCD Figure 6.2.4-11. This inconsistency was corrected but not discussed in the original TR37 markups and is also corrected in the revised TR37 markups for this RAI response.)

d) The markup for Figure 6.2.4-12 for TR37 incorrectly revised the elevation for igniter #61 to 250'0" instead of 258'0" which was inconsistent with TR37 markup for Figure 6.2.4-13. The corrected markup for Figure 6.2.4-12 is provided to reflect 258'0".

e) Two other text corrections were made as indicated in the TR37 Section III DCD mark-up for the pressurizer compartment and upper compartment descriptions in Table 6.2.4-6 to reflect the correct revised igniter elevations.

f) The loop compartment and refueling cavity discussions in Table 6.2.4-6 were added as a TR37 DCD markup in this RAI response and revised to reflect the correct elevation of the four igniters above each compartment as 166' instead of 162'.

g) The markup for Table 6.2.4-7 in TR37 was revised to reflect the correct elevation or elevation range for the igniters in each power group for the Lower Region of the Upper Compartment.

Design Control Document (DCD) Revision:

See the DCD markups provided in Section III of TR37 Revisions below.

The TR37 changes for Figures 6.2.4-5, 6.2.4-11, and 6.2.4-13 should NOT be incorporated into the DCD. The TR37 changes for these figures are superseded by changes in TR36 but TR36 includes additional changes beyond those in TR37. The TR36 changes are reflected in TR37 for completeness.

AP1000 TECHNICAL REPORT REVIEW

Response to Request For Additional Information

PRA Revision:

None

TR37 Revision:

II. TECHNICAL DESCRIPTION AND JUSTIFICATION

The elevations and locations of certain hydrogen igniters must be changed either because (1) the polar crane elevation has changed, or (2) to place the igniters in locations where they are more easily accessible or to avoid trip hazard, or (3) the pressurizer height has been changed. The compartment areas serviced by the relocated igniters and the assigned power grouping have not been revised.

Changes to igniter locations as a result of the continuing COL and detailed design activities for the AP1000 satisfy the igniter location criteria identified in DCD Table 6.2.4-6 (Sheet 1 of 3) that were used for design certification review of the hydrogen igniter subsystem and referenced in the AP1000 FSER.

Therefore, Changing the elevation or location of the specific hydrogen igniters (identified below) does not alter their design function. These changes have no effect on analysis or analysis method. There is no change to the compartment areas serviced by the relocated igniters or the assigned power grouping of the igniters. There is no change to Tier 1 information.

III. DCD MARK-UP

- **Loop Compartments** – Hydrogen releases from the hot or cold legs or from the reactor cavity would flow up through the loop compartment to the dome region. Igniter coverage provided within the loop compartment consists of a total of four igniters at two different elevations covering the perimeter of the compartment and with two igniters powered by one power group and two by the second power group. Additional coverage is provided above the loop compartments at elevation 166'462' with four igniters above each loop compartment and powered by different power groups.
- **Pressurizer Compartment** – Hydrogen releases within the pressurizer compartment would flow up through the compartment toward the dome region. Igniter coverage is provided within the compartment consists of a total of four igniters at two different elevations covering the perimeter of the compartment with two igniters powered by one power group and two by the second power group. Additional coverage is provided above the pressurizer compartment at elevation 166'462' to 464' with two igniters above powered by different power groups.

AP1000 TECHNICAL REPORT REVIEW

Response to Request For Additional Information

- **Refueling Cavity** – Hydrogen releases from the reactor cavity or from the potentially from the reactor coolant loops may flow up past the refueling cavity seal ring and through the refueling cavity to the dome region. Igniter coverage provided within the refueling consists of a total of four igniters at two different elevations covering the perimeter of the compartment with two igniters powered by one power group and two by the second power group. Additional coverage is provided above the refueling cavity at elevation 166-162' with four igniters powered by different power groups.
- **Upper Compartment** – Hydrogen control is provided at three separate levels within the upper compartment. At the 162-166-176 foot elevations, 10 igniters are distributed over the area primarily above the major release flow paths including the loop compartments, refueling cavity, pressurizer compartment, and above the stairwell from the lower compartment area.

Table 6.2.4-7

SUBCOMPARTMENT/AREA IGNITER COVERAGE

	Igniter Coverage (Elevation) ¹	
	Power Group 1	Power Group 2
Upper Compartment		
Lower Region	39, 42, 44, 43, 47 (El <u>166-162'-176'</u>)	40, 41, 45, 46, 48 (El <u>162'-166-176'</u>)

AP1000 TECHNICAL REPORT REVIEW

Response to Request For Additional Information

WESTINGHOUSE ELECTRIC COMPANY
AP1000 Licensing Design Change Document

Page 4 of 13

Document Number: APP-GW-GLN-003

Revision Number: 0

Title: Hydrogen Igniter Locations

Revise Figure 6.2.4-5 as follows:

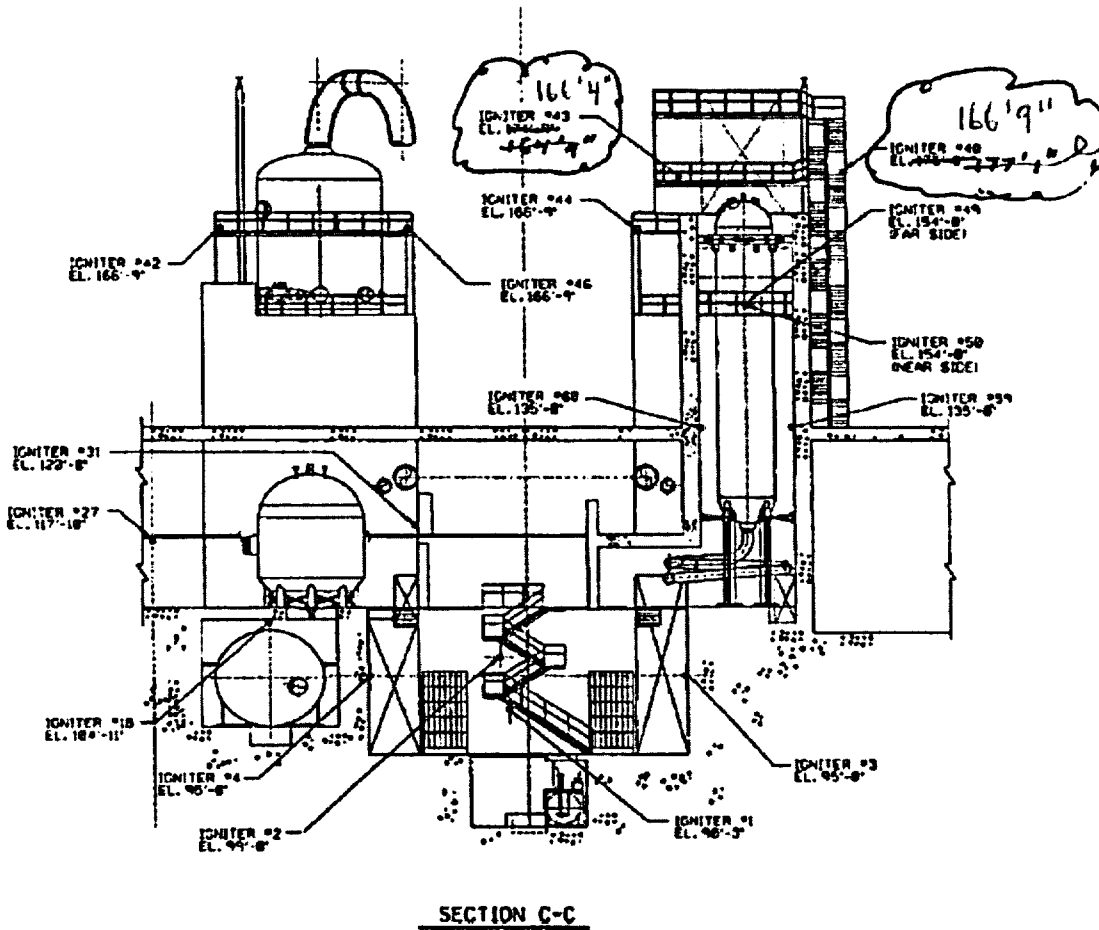

Figure 6.2.4-5

Hydrogen Igniter Locations – Section View

AP1000 TECHNICAL REPORT REVIEW

Response to Request For Additional Information

WESTINGHOUSE ELECTRIC COMPANY
AP1000 Licensing Design Change Document

Page 7 of 13

Document Number: APP-GW-GLN-003 Revision Number: 0

Title: Hydrogen Igniter Locations

Revise Figure 6.2.4-11 as follows:

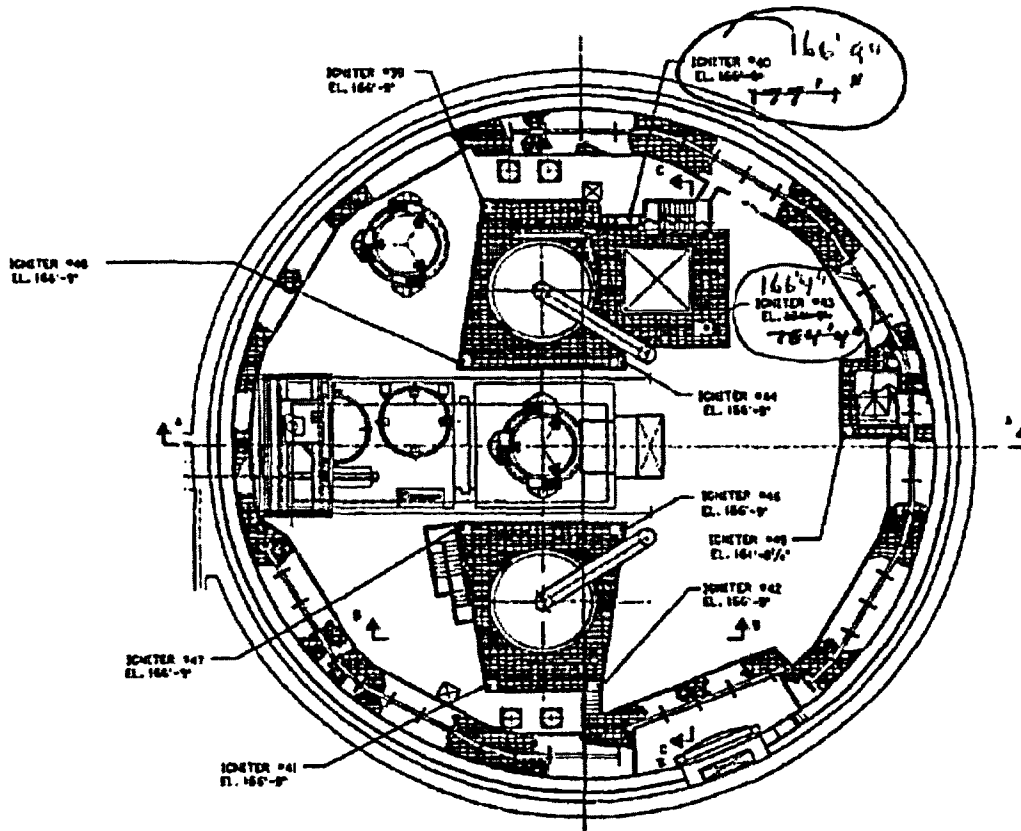

Figure 6.2.4-11

Hydrogen Igniter Locations
Plan View Elevation 162'-0"

AP1000 TECHNICAL REPORT REVIEW

Response to Request For Additional Information

WESTINGHOUSE ELECTRIC COMPANY
AP1000 Licensing Design Change Document

Page 8 of 13

Document Number: APP-GW-GLN-003 Revision Number: 0

Title: Hydrogen Igniter Locations

Figure 6.2.4-12 Revise Figure 6.2.4-12 as follows:

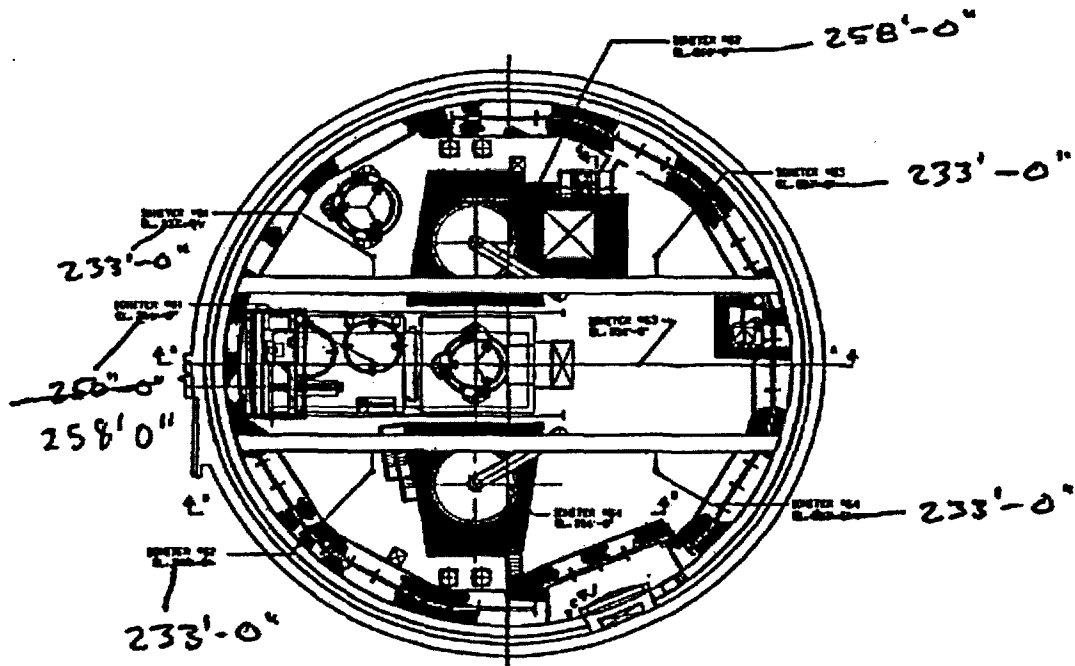

Figure 6.2.4-12

Hydrogen Igniter Locations
Plan View Elevation 210'-0"

AP1000 TECHNICAL REPORT REVIEW

Response to Request For Additional Information

WESTINGHOUSE ELECTRIC COMPANY
AP1000 Licensing Design Change Document

Page 9 of 13

Document Number: APP-GW-GLN-003 Revision Number: 0

Title: Hydrogen Igniter Locations

Figure 6.2.4-13 Revise Figure 6.2.4-13 as follows:

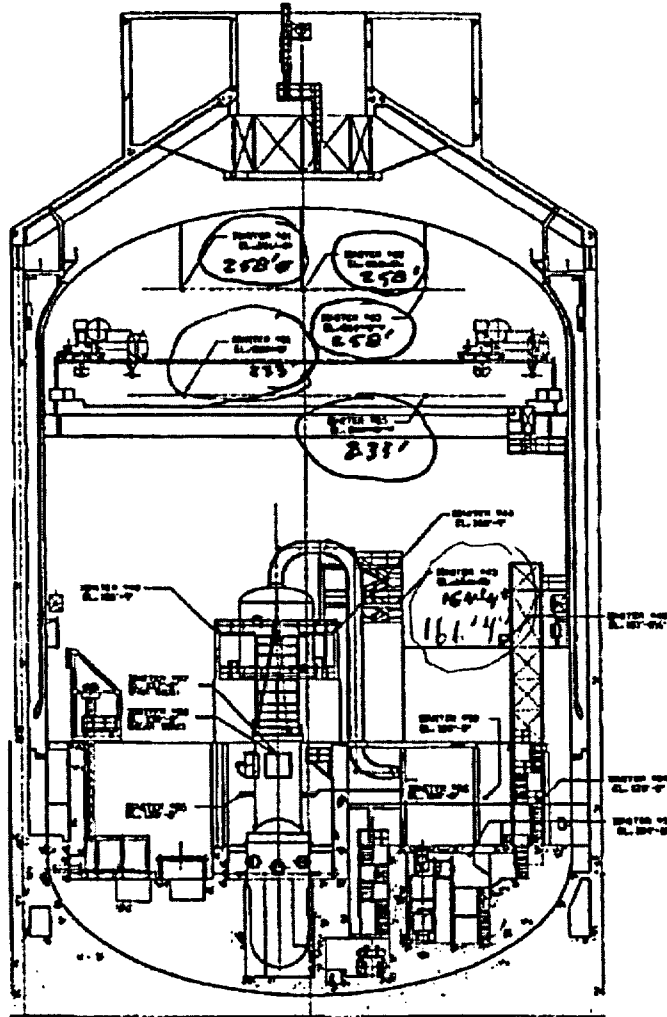

SECTION A-A

Figure 6.2.4-13

Hydrogen Igniter Locations Section A-A