

## 1.0 INTRODUCTION

The Technical Specification Task Force (TSTF) has proposed TSTF-425, which relocates the majority of the Technical Specification Surveillance Requirement Frequencies to a licensee-controlled program. The Surveillance Requirements would remain in the Technical Specifications, pursuant to 10 CFR 50.36. The Administrative Controls section of the Technical Specifications would specify the requirements for a Surveillance Frequency Control Program (SFCP) that the licensee would use to control Surveillance Frequencies<sup>1</sup> and make future changes to the Surveillance Requirement Frequencies.

The Surveillance Frequency Control Program states:

### 5.5.15 Surveillance Frequency Control Program

This program provides controls for Surveillance Frequencies. The program shall ensure that Surveillance Requirements specified in the Technical Specifications are performed at intervals sufficient to assure the associated Limiting Conditions for Operation are met.

- a. The Surveillance Frequency Control Program shall contain a list of Frequencies of those Surveillance Requirements for which the Frequency is controlled by the program.
- b. Changes to the Frequencies listed in the Surveillance Frequency Control Program shall be made in accordance with NEI 04-10, "Risk-Informed Method for Control of Surveillance Frequencies."
- c. The provisions of Surveillance Requirements 3.0.2 and 3.0.3 are applicable to the Frequencies established in the Surveillance Frequency Control Program.

Deleted: within the Surveillance Frequency Control Program

This document provides a risk-informed process and methodology for implementing the SFCP to control the relocated Technical Specification Surveillance Requirement Frequencies for structures, systems and components (SSC). The methodology of this document, once accepted by Nuclear Regulatory Commission, provides the basis for maintaining and changing the Technical Specification Surveillance Frequencies in accordance with the SFCP.

---

<sup>1</sup> The term Surveillance Test Interval (STI) is used in the SFCP change process description to describe the time interval associated with the Surveillance Frequency specified in the Technical Specification. A change to the STI is analogous to a change in the Surveillance Frequency.

## 2.0 OVERALL APPROACH

The SFCP shall ensure that Surveillance Requirements specified in the Technical Specifications are performed at intervals sufficient to assure the associated Limiting Conditions for Operation (LCOs) are met. Existing regulatory programs, such as 10 CFR 50.65 (the Maintenance Rule) and the corrective action program required by 10 CFR 50, Appendix B, require monitoring of Surveillance test failures and require action be taken to address such failures. One of these actions may be to consider changing the Frequency at which a Surveillance is performed. These regulatory requirements are sufficient to ensure that Surveillance Frequencies which are insufficient to assure the LCO is met are identified and action taken. In addition, the SFCP requires monitoring of Surveillance Frequencies that are changed using the process described in this document.

The approach for changing Surveillance Frequencies uses existing Maintenance Rule implementation guidance (NUMARC 93-01, Rev. 3) (Reference 2), combined with elements of NRC In-service Testing Regulatory Guide (RG) 1.175 (Reference 5), to develop risk-informed test intervals for SSCs having Technical Specification Surveillance Requirements. Although originally developed to address test intervals for pump and valve testing required by the ASME Code, the concepts of RG 1.175 are applicable to the SFCP with minor modifications. In particular, this Regulatory Guide provides information relative to modeling the effect of the revised Surveillance Frequencies in a probabilistic risk assessment (PRA).

The method described here is also consistent with RG 1.174 (Reference 3), “An Approach for Using Probabilistic Risk Assessments in Risk-Informed Decisions on Plant-Specific Changes to the Licensing Basis,” and RG 1.177 (Reference 4), “An Approach for Plant-Specific Risk-Informed Decisionmaking: Technical Specifications” and provides more specific guidelines to facilitate application by the licensee. RG 1.177 provides guidance for changing Surveillance Frequencies and Completion Times. However, for allowable risk changes associated with Surveillance Frequency changes, it refers to RG 1.174. The regulatory guide provides quantitative risk acceptance guidelines for changes to core damage frequency (CDF) and large early release frequency (LERF), along with additional guidelines that have been adapted for this methodology.

The detailed SFCP process is described in Section 4. PRA technical adequacy will be addressed through NRC RG 1.200 (Reference 6). Following the establishment of adequate PRA capability, the process involves the development of revised Surveillance Frequencies (i.e., STIs) based on risk insights from PRAs, plant operational experience, and other factors. The effect of the proposed change, aggregate risk impact<sup>2</sup> of the single revised Surveillance Frequency for all PRA events, and the cumulative risk impact for all Surveillance Frequency changes will be compared to NRC risk acceptance guidelines. Feedback and periodic re-evaluation of the Surveillance Frequencies will be conducted for SSCs.

---

<sup>2</sup> Also referred to as total risk impact in this document.

### 3.0 KEY SAFETY PRINCIPLES FOR CHANGING FREQUENCIES

RG 1.174 identifies five key safety principles to be met for all risk-informed applications and to be explicitly addressed in risk-informed plant program change applications.

Figure 1 of RG 1.174 illustrates the consideration of each of these principles in risk-informed decision-making.

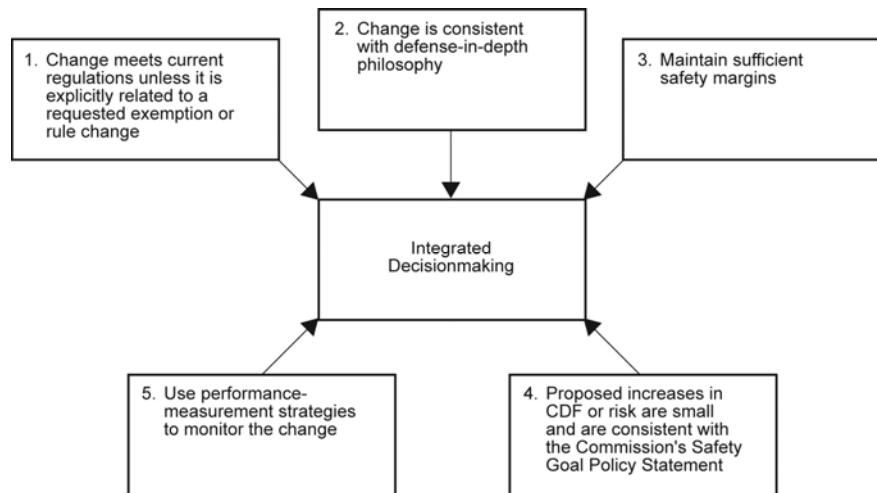

**1. The proposed change meets the current regulations unless it is explicitly related to a requested exemption or rule change.**

10 CFR 50.36(c) provides that Technical Specifications will include items in the following categories:

“(3) *Surveillance Requirements*. Surveillance requirements are requirements relating to test, calibration, or inspection to assure that the necessary quality of systems and components is maintained, that facility operation will be within safety limits, and that the limiting conditions for operation will be met.”

Technical Specifications Initiative 5B and TSTF-425 propose to relocate the Surveillance Frequencies for most Surveillance Requirements to a licensee-controlled program using an NRC-approved methodology for control of the Surveillance Frequencies. The Surveillance Requirements themselves would remain in Technical Specifications.

This change is consistent with other NRC-approved TS changes in which the Surveillance Frequencies are not under NRC control, such as Surveillances that are performed in accordance with the In-service Testing Program or the Primary Containment Leakage Rate Testing Program, where the Frequencies vary based on

the past performance of the subject components. Thus, this proposed change meets criterion 1 above.

## **2. The proposed change is consistent with the defense-in-depth philosophy.**

Consistency with the defense-in-depth philosophy is maintained if:

- A reasonable balance is preserved among prevention of core damage, prevention of containment failure, and consequence mitigation.
- Over-reliance on programmatic activities to compensate for weaknesses in plant design is avoided.
- System redundancy, independence and diversity are preserved commensurate with the expected frequency, consequences of challenges to the system, and uncertainties (e.g., no risk outliers).
- Defenses against potential common cause failures are preserved, and the potential for the introduction of new common cause failure mechanisms is assessed.
- Independence of barriers is not degraded.
- Defenses against human errors are preserved.
- The intent of the General Design Criteria in 10 CFR Part 50, Appendix A is maintained.

These defense-in-depth objectives apply to all risk-informed applications and, for some of the issues involved (e.g., no over-reliance on programmatic activities and defense against human errors), it is fairly straightforward to apply them to this proposed change. The use of the multiple risk metrics of core damage frequency (CDF) and large early release frequency (LERF) and controlling their change resulting from the implementation of this initiative would maintain a balance between prevention of core damage, prevention of containment failure, and consequence mitigation. Redundancy, diversity and independence of safety systems are considered as part of the risk categorization to ensure that these qualities are not adversely affected. Independence of barriers and defense against common cause failures are also considered in the categorization. The improved understanding of the relative importance of plant components to risk resulting from the development of this program should promote an improved overall understanding of how the SSCs contribute to a plants defense in depth.

## **3. The proposed change maintains sufficient safety margins.**

Conformance with this principle is assured with proposed changes to Surveillance Frequencies since the SSC design, operation, testing methods, and acceptance criteria specified in applicable Codes and Standards, or alternatives approved for use by the

NRC, will continue to be met as described in the plant licensing basis (e.g., FSAR, or Technical Specifications Bases). Also, the safety analysis acceptance criteria in the plant licensing basis (e.g., FSAR, supporting analyses) will continue to be met with the proposed changes to Surveillance Frequencies.

**4. When proposed changes result in an increase in core damage frequency or risk, the increases should be small and consistent with the intent of the Commission's Safety Goal Policy Statement.**

In the SFCP, the overall impact of the change is assessed and compared to the quantitative risk acceptance guidelines of RG 1.174, which is consistent with the intent of the Commission's Safety Goal Policy Statement. Two types of effects on CDF and LERF are considered. The first effect involves the total or aggregate risk impact for all PRA events for each individual Surveillance Frequency change. The second effect involves the cumulative risk impact from all Surveillance Frequency changes. More detail is provided in subsequent paragraphs that describe the SFCP process. The PRA used to support this change will, at a minimum, address CDF and LERF for power operation. External event risk and shutdown considerations will be addressed through quantitative or qualitative means.

NRC RG 1.200 addresses technical adequacy of PRA for risk-informed applications. This regulatory guide will be followed for plants proposing to implement Initiative 5B through TSTF-425 and the SFCP.

**5. The impact of the proposed change should be monitored using performance measurement strategies.**

A performance monitoring strategy will be developed to provide confidence that the equipment performance is consistent with the considerations of the overall SFCP process, and is not degrading such that the analysis assumptions and expert panel judgments are no longer valid. For certain cases, existing performance monitoring required by the Maintenance Rule is adequate for SSCs whose Surveillance Frequencies are controlled under the SFCP. The output of the performance monitoring will be periodically re-assessed, and appropriate adjustments made to the Surveillance Frequencies.

## 4.0 SURVEILLANCE FREQUENCY CONTROL PROGRAM CHANGE PROCESS

The SFCP change process is shown in flow diagrams in the Figures 1, 2 and 3. The process steps are described below:

### Step 0: Select Proposed STIs for Adjustment

The initial step in the SFCP change process is to select proposed surveillance test intervals (STIs) for adjustment. STIs may need to be adjusted as a required action in response to monitoring surveillance test failures in accordance with 10 CFR 50.65 (the Maintenance Rule) and the corrective action program required by 10 CFR 50, Appendix B. In addition, STIs may be adjusted to realize specific benefits. Inputs to the selection of STIs for adjustment should be obtained from various site organizations, such as, Operations, Outage Management, Work Management, Health Physics, Licensing, and Engineering. The following is a representative list (not inclusive) of potential factors/benefits that should be considered in identifying candidate STIs for adjustment:

1. Safety risk
2. Reactivity management.
3. Maintaining dose as low as reasonably achievable (ALARA).
4. Burden reduction, including consideration of cost of the test (resources).
5. Outage impact (outage work control).
6. Work management simplification (on-line work control).
7. Production risk.
8. Reducing wear and tear on the SSC.
9. Reducing potential for test-caused errors.
10. Difficulty of the test and potential for error during the test and its consequence.
11. Consideration of the role of the test on the reliability of the associated function.
12. Maintenance Rule A1 item that has an associated action plan that necessitates more frequent testing.
13. Maintenance Rule and the associated corrective action process that necessitates more frequent testing.

In addition, for an STI previously extended through the Surveillance Frequency Control Program, the minimum number of surveillance intervals required to establish an adequate database for further extending the STI shall be as follows:

- (1) a minimum of three successive satisfactory performances of the surveillance where the STI is less than or equal to six months,
- (2) a minimum of two successive satisfactory performances of the surveillance where the STI is greater than six months but no greater than two fuel cycles, or
- (3) another defined period of satisfactory performance(s) of the surveillance based on a documented technical justification.

Formatted: Bullets and Numbering

NOTE: The criteria provided above do not apply to phased implementation. If phased implementation is used, the schedule for the phased implementation is recommended based on the results of the evaluation (Step 15) and is approved by the Independent Decisionmaking Panel as part of their approval of the proposed STI change (Step 16).

**Step 1: Check for Prohibitive Commitments**

In Step 1, all the commitments made to the NRC are collected and reviewed. Some of the commitments to maintain a certain surveillance test interval may have been made in relation to certain other plant issues. As part of this step, such commitments are identified and then, in Step 2, the commitments are examined to determine if they can be changed. If there are no such commitments, then the STI change process continues in Steps 5 and 6.

**Step 2: Can Commitments be Changed?**

In Step 2, a check is made to determine if the NRC commitments can be changed. Evaluating changes to the NRC commitments is a separate activity based on a method acceptable to the NRC for managing and changing regulatory commitments, e.g., NEI 99-04. If the commitments can be changed without prior NRC approval, go to Step 3 for changing the commitments. If the commitments cannot be changed without prior NRC approval, go to Step 4.

**Step 3: Change the Commitments**

In Step 3, change the commitments using a method acceptable to the NRC, e.g., NEI 99-04, such that the STI can be revised using the SFCP process. Return to the SFCP process after the commitments have been changed and continue the SFCP process with Steps 5 and 6.

**Step 4: Document that STI Changes Cannot be Changed**

This step is entered if, in Step 2, it is determined that the commitment related to a certain STI cannot be changed. Document that STI cannot be changed and the process concludes here.

Alternatively, Step 4 is entered if PRA or qualitative analyses result in the STI change being unacceptable. In that case, the reasons that the STI change is not acceptable should also be documented and the process concludes here for the specific STI being investigated.

**Step 5: RG 1.200 PRA Technical Adequacy**

NRC has developed a regulatory guidance for trial use to address PRA technical capability. This is RG 1.200 (Reference 6), which addresses the use of the ASME

PRA standard, and the NEI peer review process (NEI 00-02) for evaluating PRA technical capability.

RG 1.200 also provides (or will provide) attributes of importance for risk determinations relative to external events, seismic, internal fires, and shutdown.

Plants implementing TSTF-425 shall evaluate their PRAs in accordance with this regulatory guide. The RG specifically addresses the need to evaluate important assumptions that relate to key modeling uncertainties (such as reactor coolant pump seal models, common cause failure methods, success path determinations, human reliability assumptions, etc). Further, the RG addresses the need to evaluate parameter uncertainties and demonstrate that calculated risk metrics (e.g., CDF and LERF) represent mean values. The identified "Gaps" to Capability Category II requirements from the endorsed PRA standards in the RG and the identified key sources of uncertainty serve as inputs to identifying appropriate sensitivity cases in Step 14 below.

#### **Step 6: Select Desired Revised STI Values**

Earlier in Step 0, Technical Specifications STIs are identified for adjustment. This identification is done based on a number of factors, which among others include, the difficulty of the test, cost of the test, potential for error during the test and its consequence, and the role of the test on the reliability of the associated function. As part of Step 6, the licensee should identify the desired revised STI values. In general, the next logical STI given in technical specifications is chosen for improvement. For example, an STI of one month would be changed to quarterly, quarterly to semi-annual, semi-annual to annual, etc. If a STI was chosen which goes beyond the next logical interval, a phased implementation would probably be more appropriate and would need to be considered in Step 15.

Following this step, the SFCP process diverges into two paths, both of which need to be followed. One path, starting at Step 7 performs a qualitative evaluation and the other path, starting at Step 8 leads to a quantitative evaluation. Both paths converge later at Step 15.

#### **Step 7: Identify Qualitative Considerations to be Addressed**

Qualitative considerations are developed as an input to the IDP. Such considerations include, but are not limited to:

- Surveillance test and performance history of the components and system associated with the STI adjustment.
- Uncertainty associated with the quantitative process.
- The impact of systems not quantified using the internal event PRA.



Deleted: 3

Deleted: May

- The impact of systems for which LERF results are not available.
- The impact of systems for which external events and shutdown PRA are not available.
- Past industry and plant-specific experience with the functions affected by the proposed changes.
- Impact on defense-in-depth protection.
- Vendor-specified maintenance frequency.
- Test intervals specified in applicable industry codes and standards, e.g., ASME, IEEE, etc.
  - Review both committed and current codes and standards.
  - Align the considerations with the technical basis, if any, provided for test intervals in the codes and standards.
- Impact of a SSC in an adverse or harsh environment.
- Benefits of detection at an early stage of potential mechanisms and degradations that can lead to common cause failures.
- Confirm that assumptions in the plant licensing basis would not be invalidated when performing the surveillance at the bounding interval limit for the proposed STI change. For example, if the assumptions in the plant licensing basis would be invalidated at the bounding STI, the STI could be limited accordingly, or, for acceptance criteria not specified in the Technical Specifications, a more conservative acceptance criteria could be established, as appropriate.
- The degree to which the surveillance provides a conditioning exercise to maintain equipment operability, for example, lubrication of bearings or electrical contact wiping (cleaning) of built up oxidation, and limit the STI accordingly.

Deleted: Consider applicable ASME, IEEE, and other code-specified test intervals

Formatted

Formatted: Bullets and Numbering

Formatted

Deleted: Consideration of the

Deleted: Consideration of the

Formatted

Formatted: Bullets and Numbering

Formatted

Formatted

The above list of qualitative considerations is not intended to be a complete list. The System Engineering Team will add other qualitative consideration based on their expertise, knowledge of the specific SSC under consideration, and past experience. The IDP in their review of the STI change follows through these qualitative considerations.

The qualitative considerations are summarized in Step 15 and presented to the IDP (Step 16) along with the quantitative considerations from Step 14 and qualitative or bounding analyses from Steps 10a, 10b, and 10c.

#### Step 8: Associated STI SSC Modeled in PRA?

(Note: Parts of the discussion in Step 10 relating to initial assessments of various types of PRAs is applicable here also. It was included in Step 10 for ease of presentation).

In Step 8, check if the surveillance or the associated systems, or components, are modeled in the PRA. At this point, the focus is on the full power internal events PRA, although the question is applicable for external events PRA and shutdown PRA as well.

In general, the failure probability values of components used in PRAs consist of a time-related contribution (i.e. the standby time-related failure rate) and a cyclic demand-related contribution (i.e. the demand stress failure probability). The risk impact of a proposed STI adjustment shall be calculated as a change of the test-limited risk (see Regulatory Guide 1.177, Section 2.3.3). Since the test-limited risk is associated with failures occurring between tests, the failure rate that shall be used in calculating the risk impact of a proposed STI adjustment is the time-related failure rate associated with failures occurring while the component is in standby between tests (i.e. risk associated with the longer time to detect standby-stress failures). Therefore, caution should be taken in dividing the failure probability into time-related and cyclic demand-related contributions because the test-limited risk can be underestimated when only part of the failure rate is considered as being time-related while this may not be the case. Thus, if a breakdown of the failure probability is considered, it shall be justified through data and/or engineering analyses. When the breakdown between time-related and demand-related contributions is unknown, all failures shall be assumed to be time-related to obtain the maximum test-limited risk contribution.

In practice, to assess if the STI change can be adequately characterized by the PRA the following actions shall be taken:

- Determine all components that are uniquely impacted by the proposed STI change. That is, develop a list of components that are only exercised by the test such that their test-limited risk contribution would be directly affected by the STI change. Establish that the PRA modeled components sufficiently represent the components uniquely impacted by the proposed STI change.
- Determine an appropriate time-related failure contribution for the all of the components to be analyzed as identified in the previous step. The time-related failure contribution can be based on recognized data sources or plant-specific data. If neither is available, then as indicated above, the total failure probability shall be assumed to be time-related.
- Ensure that the model includes appropriate common cause failure terms for the components that are uniquely impacted by the STI change.

If all three of the conditions are appropriately included in the PRA model, then proceed to Step 12 to perform the Total and Cumulative CDF and LERF evaluation

for the revised STI values. If the base PRA model does not appropriately address one or more of the three pre-conditions, then proceed to Step 9.

**Step 9: Can STI Be Modeled in PRA?**

Step 9 is entered if in Step 8 it is determined that the systems or components associated with the STI are not adequately included in the base PRA model. In this step, the analyst has to decide if the STI can be adequately characterized in the PRA model. The determination pertains to all PRAs, including external events and shutdown, but the initial focus is on the internal events PRA.

If it is determined that the STI can be adequately modeled in the PRA with some revisions, proceed to Step 11. Otherwise, proceed to Step 10.

**Step 10: Perform Qualitative or Bounding Risk Analysis**

(Note: A detailed account of how to approach the various types of PRAs, (internal events, external events and shutdown), is given as part of description of this step. Portions of the descriptions are applicable only to Step 8 described earlier. However, they have been included here for a more cohesive presentation.)

Step 10 is entered from Step 9 when it is determined that the STI change cannot be modeled in the plant PRA. In such a case, the PRA analyst will have to perform qualitative or bounding analysis that would provide some indication of the impact of the STI change on the results. A qualitative analysis would involve no use of numerical values in the assessments, whereas a bounding analysis would involve some use of numerical values in the assessment. To account for the potential different approaches and the special considerations associated with the different risk contributors, this step has been subdivided to provide further clarification.

*Overview of Initial Assessments*

An initial qualitative evaluation can be performed at the system/structure level. If the system/structure is found to have a role in a particular portion of the plant's risk profile, then a component level evaluation can be performed. This qualitative assessment must be performed for all risk contributors (internal events, external events, and shutdown), and the STI change must still be assessed for other considerations (see Step 7) and presented to the IDP.

Some guidelines for performing initial assessments for each of the risk contributors are given below. The results of the assessment will lead to one of the following outcomes:

1. The qualitative information is sufficient for presentation to the IDP.
2. The assessment confirms the conclusion in Step 8 that the STI change can be evaluated in the PRA(s) and the evaluation continues in Step 12.

3. The assessment results in the identification of potential contributors that become candidates for bounding analysis (refer to Step 10b and 10c).
4. Depending on the outcome from the bounding analysis in Steps 10b and 10c, there is also the potential that more detailed modeling could be desirable to perform an appropriate evaluation of the STI change. In that case, the process would refer back to Step 11 to revise the PRA as needed to perform the detailed assessment.

#### *Initial Assessment for Internal Events*

If an SSC is involved in the prevention or mitigation of severe accidents, then the first risk contributor evaluated is from the internal events PRA. The question of whether an SSC is evaluated in the internal events PRA (or any of the analyses considered in this guideline) must be answered by considering not only whether it is explicitly modeled in the PRA (i.e., in the form of basic event(s) – see Step 8), but also whether it is implicitly evaluated in the model through operator actions, super components or another aggregated events sometimes used in PRAs. The term “evaluated” means:

- Can its failure contribute to an initiating event?
- Is it credited for prevention of core damage or large early release?
- Is it necessary, for another system or structure evaluated in the PRA, to prevent an event or mitigate an event?

PRA personnel knowledgeable in the scope, level of detail, and assumptions of the plant-specific PRA shall make these determinations. Certain SSCs are implicitly modeled in the PRA. By examining the attributes listed above, it is possible to address even implicitly modeled components. If in Step 8, the SSC was determined to be explicitly modeled and evaluated in the internal events PRA, then the internal event evaluation process is used to determine the acceptability of the STI change as depicted in Step 12. However, if it is determined that the SSC is only implicitly modeled, then there is a choice of performing either a bounding analysis as described in Step 10b or a detailed analysis as described in Step 11.

If the SSC is not evaluated in the internal events PRA (either explicitly or implicitly, and it is judged to have no impact on the PRA results), then the SSC can be qualitatively screened with the information summarized in Step 15 for presentation to the IDP. This initial screening is from the standpoint of internal events as not having an impact on the CDF and LERF metrics. The evaluation is continued with fire risk.

### *Initial Assessment for Fire Events*

If the plant has a fire PRA, then the next step of the screening process is to determine whether the SSC is evaluated in the fire PRA. (The term “evaluated” is explained above under discussion of internal events). In making this determination, specific attention should be given to structures and the role they play as fire barriers in the fire PRA. PRA personnel knowledgeable in the scope, level of detail, and assumptions of the plant-specific fire PRA shall make the determinations with respect to fire PRAs. If in Step 8, the SSC is determined to be explicitly modeled and evaluated in the fire PRA, then the fire PRA evaluation process is used to determine the fire risk metric inputs associated with the STI change as depicted in Step 12. However, if it is determined that the SSC is only implicitly modeled, then there is a choice of performing either a bounding analysis as described in Step 10b or a detailed analysis as described in Step 11.

If the plant does not have a fire PRA, then a fire risk evaluation, such as the EPRI Fire Induced Vulnerability Evaluation (FIVE) that was performed in response to IPEEE may be used for the evaluation or an application-specific fire analysis can be performed. Again, it is important that personnel knowledgeable in the scope, level of detail, and assumptions of the fire risk evaluation (FIVE) make these determinations. If in Step 8 the SSC is determined to be explicitly modeled and evaluated in the FIVE analysis, then the FIVE process may be utilized to determine the acceptability of the STI change as depicted in Step 12 or an application-specific fire analysis can be performed.

If the SSC is determined to be only implicitly modeled in the FIVE methodology process, then there is a choice of performing either a bounding analysis as described in Step 10b or a detailed analysis as described in Step 11. Because FIVE is a conservative screening analysis, care should be exercised in adding the risk increase values from FIVE evaluation to the total increase from all other PRA results.

If the SSC is not evaluated in either the fire PRA or FIVE evaluations, (either explicitly or implicitly, and it is judged to have no impact on the PRA results), then the SSC can be qualitatively screened with the information summarized in Step 15 for presentation to the IDP. This initial screening is from the standpoint of fire events as not having an impact on the CDF and LERF metrics. The evaluation is continued with seismic risk.

### *Initial Assessment for Seismic Events*

If the plant has a seismic PRA, then the next step of the screening process is to determine whether the SSC is evaluated in the seismic PRA. (The term “evaluated” is explained above under discussion of internal events). Often, structures are explicitly modeled in seismic PRAs. Again, PRA personnel knowledgeable in the scope, level of detail, and assumptions of the plant specific seismic PRA shall make these determinations. If the SSC is determined to be explicitly modeled and evaluated in the seismic PRA, then the seismic PRA evaluation process is used to

determine the seismic risk metric inputs of the STI change as depicted in Step 12. However, if it is determined that the SSC is only implicitly modeled, then there is a choice of performing either a bounding analysis as described in Step 10b or a detailed analysis as described in Step 11.

If the plant does not have a seismic PRA, then a seismic risk evaluation, such as a seismic margins analysis (SMA) that was performed in response to the IPEEE may be used for the evaluation. Steps 8 and 9 are not applicable for this case. Personnel knowledgeable in the scope, level of detail, and assumptions of the SMA shall determine the seismic importance. If the SSC structure is included in the SMA, then qualitative information must be developed that supports the acceptability of the STI change with respect to the seismic risk (go to Step 10a).

If the SSC is not evaluated in the seismic PRA, (either explicitly or implicitly, and it is judged to have no impact on the PRA results), or not evaluated in the SMA (either explicitly or implicitly), then the SSC can be qualitatively screened with the information summarized in Step 15 for presentation to the IDP. The evaluation is continued with other external events risk.

#### *Initial Assessment for Other External Events*

If the plant has a PRA that evaluates other external hazards, then the next step of the screening process is to determine whether the SSC is evaluated in the external hazards PRA. (The term “evaluated” is explained above under discussion of internal events). Often, structures are explicitly modeled in external hazards PRAs. Personnel knowledgeable in the scope, level of detail, and assumptions of the external hazards PRA shall make these determinations. If the SSC is determined to be explicitly modeled and evaluated in the external hazards PRA, then the external hazards PRA evaluation process is used to determine the external hazards risk metric inputs of the STI change as depicted in Step 12. However, if it is determined that the SSC is only implicitly modeled, then there is a choice of performing either a bounding analysis as described in Step 10b or a detailed analysis as described in Step 11.

If the plant does not have an external hazards PRA, then it is likely to have an external hazards screening evaluation that was performed to support the requirements of the IPEEE. Once again, personnel knowledgeable in the scope, level of detail, and assumptions of the external hazards analysis shall make these determinations. If the SSC is evaluated in the external hazards analysis, then qualitative information must be developed that supports the acceptability of the STI change with respect to the external hazards risk for consideration in Step 10a. If the SSC is not involved in either an external hazards PRA or external hazards screening evaluation, then the SSC can be screened qualitatively with the information presented to the IDP. This initial screening is from the standpoint of external hazards risk as not having an impact on the CDF and LERF metrics. The evaluation is continued with shutdown risk.

### *Initial Assessment for Shutdown Events*

If the plant has a shutdown PRA, then the next step of the screening process is to determine whether the SSC is evaluated in the shutdown PRA. (The term “evaluated” is explained above under discussion of internal events). Personnel knowledgeable in the scope, level of detail, and assumptions of the shutdown PRA shall make the determination. If the SSC is explicitly modeled and evaluated in the shutdown PRA, then the shutdown PRA evaluation process is used to determine the external hazards risk metric inputs of the STI change as depicted in Step 12. However, if it is determined that the SSC is only implicitly modeled, then there is a choice of performing either a bounding analysis as described in Step 10b or a detailed analysis as described in Step 11.

If the plant does not have a shutdown PRA, then it is likely to have a shutdown safety program developed to support implementation of NUMARC 91-06 and, if so, this may be used for the evaluation, or application-specific shutdown analysis may be performed. Once again, personnel knowledgeable in the scope, level of detail, and assumptions of the NUMARC 91-06 program shall make this determination. If the SSC is determined to be credited in the NUMARC 91-06, then qualitative information must be developed that supports the acceptability of the STI change with respect to the shutdown risk for consideration in Step 10a.

If the SSC is not involved in a shutdown PRA or NUMARC 91-06, then the SSC can be screened qualitatively with the information presented to the IDP. This initial screening is from the standpoint of shutdown risk as not having an impact on the CDF and LERF metrics.

#### **Step 10a: Qualitative Analysis Sufficient for IDP?**

This step is performed to determine if qualitative information is sufficient to provide confidence that the net impact of the STI change would be negligible (or zero) from a CDF and LERF perspective. It is recognized that in certain cases, such as a SMA, qualitative analysis is the only evaluation that can be performed.

For each risk contributor as determined in the initial assessments performed in Step 10 above, if the qualitative information is deemed sufficient, then proceed to Step 15 and provide the basis for the qualitative conclusions to the IDP. Since only qualitative considerations are provided in this case, the impacts of the STI change are not incorporated into the cumulative impacts described in Step 12.

However, if the qualitative information is not deemed sufficient for each contributor, then proceed to Step 10b to perform a bounding analysis as required.

If the seismic risk was evaluated using the SMA, then, in the SMA, a determination shall be made if the SSC impacted by the STI change is part of the success path or not, and the information conveyed to the IDP in Step 15. Similarly, if the plant had performed other external hazards analysis or a NUMARC 91-06 safety program for

shutdown risk, a qualitative evaluation shall be made by personnel knowledgeable in the scope, level of detail, and assumptions of the analysis to conclude if the SSC impacted by the STI change has an important contribution in the evaluation, and the information conveyed to the IDP in Step 15.

#### **Step 10b: Bounding Analysis Below 1E-07/yr CDF and 1E-08/yr LERF?**

This step is performed to provide bounding impacts from the STI change given that qualitative considerations alone were deemed insufficient to bring to the IDP.

As an example, bounding analysis is performed for those SSCs that are not explicitly modeled in the PRA model, but rather are implicitly included in the model at the initiating event, mitigating system, or functional level. In that case, a basic event (or basic events) associated with the initiating event, mitigating system, or function is identified to use as surrogate for the SSC to be investigated. Reasonable variations to the basic event value(s) should then be explored to determine the potential bounding impact of the STI change.

Alternative evaluations for the impact from external events and shutdown events are also deemed acceptable at this point. For example, if the  $\Delta$ CDF and  $\Delta$ LERF values have been demonstrated to be very small from an internal events perspective based on detailed analysis of the impact of the SSC being evaluated for the STI change, and if it is known that the CDF or LERF impact from external events (or shutdown events as applicable) is not specifically sensitive to the SSC being evaluated (by qualitative reasoning), then the detailed internal events evaluations and associated required sensitivity cases (as described in Step 14) can be used to bound the potential impact from external events and shutdown PRA model contributors. As another example, if the  $\Delta$ CDF and  $\Delta$ LERF values have been demonstrated to be very small from an internal events perspective based on detailed analysis of the impact of the SSC being evaluated for the STI change, and if it is known that the plant CDF and LERF results of the external event or shutdown PRA are much smaller than the corresponding values for the internal event full power PRA, (that is, less than 10%), then the results of the internal events analysis alone would suffice for the STI consideration. This example is likely to be applicable for a situation where the SSC associated with the STI change is modeled in the internal event full power PRA, but not in the external event or shutdown PRA.

If the bounding analysis indicates that the  $\Delta$ CDF and  $\Delta$ LERF evaluation is below the 1E-07/yr CDF and 1E-08/yr LERF limits, then proceed to Step 15 and provide the results of the bounding analysis to the IDP. However, since the STI is not directly modeled in the PRA but the bounding analysis shows that the impact of the STI change is negligible, then the impacts of the STI change are not incorporated into the cumulative impacts described in Step 12.

If the bounding analysis does not indicate that the STI change is below the 1E-07/yr CDF and 1E-08/yr LERF limits, consider a revised STI value and proceed to Step 10c.



### **Step 10c: Revised STI Values Allow Bounding Analysis Below 1E-07/yr CDF and 1E-08/yr LERF?**

It is not anticipated that this step will be answered in the affirmative too often, but is provided for completeness. This step is entered if the bounding analysis indicates that the results are not below the 1E-07/yr CDF and 1E-08/yr LERF limits at the desired STI value, but could be below the limits if a reduced STI value is attempted. If it is appropriate, at this stage, the PRA model can be refined to help model the STI change more explicitly than in the original model.

If the revised bounding analysis indicates that the STI change is below the 1E-07/yr CDF and 1E-08/yr LERF limits, then proceed to Step 15 and provide the results of the bounding analysis performed in Steps 10b and 10c to the IDP. However, since the STI is not directly modeled in the PRA but the bounding analysis shows that the impact of the STI change is negligible, then the impacts of the STI change are not incorporated into the cumulative impacts described in Step 12.

If the revised bounding analysis does not indicate that the STI change is below the 1E-07/yr CDF and 1E-08/yr LERF limits, then proceed to Step 4, document that the STI cannot be changed and stop. Alternatively, one could determine that detailed modeling could be performed to more accurately reflect the CDF and LERF impacts from the STI change. In that case, one would proceed to Step 11 to revise the PRA as needed to perform a more detailed assessment.

### **Step 11: Revise PRA Model as Needed**

Step 11 is entered from Step 9 when it is determined that the STI change can be modeled in the PRA, but some revisions are required, or from Step 10 when bounding analysis are not sufficient to support the STI change request. In either case, the following actions are required:

- Modify the PRA model as required to ensure that it includes adequate representations of the items identified in Step 8.
- If necessary, re-establish base case CDF and LERF values based on the current STI values for the affected components.

Upon completion of this step, one proceeds to Step 12 to perform the Total and Cumulative CDF and LERF evaluation for the revised STI values.

### **Step 12: Evaluate Total and Cumulative Effect on CDF and LERF (See Figure 2)**

In Step 12, two types of effects on CDF and LERF are considered from all PRAs (internal events, external events, and shutdown). The first effect involves the total change to CDF/LERF results from all PRAs for individual STI changes, and the second effect involves the cumulative CDF/LERF change from all STI changes. These are described below.

- a) For each individual STI analyzed, total change in CDF/LERF for all PRAs (i.e., internal events, external events, and shutdown events), shall be less than an acceptance criterion of  $1E-06/\text{yr}$  for CDF and  $1E-07/\text{yr}$  for LERF. These  $\Delta\text{CDF}$  and  $\Delta\text{LERF}$  values are carried forward to b) where the cumulative change of all STI changes is considered.

However, as shown in Step 12-B2, where conservative or bounding estimates of CDF/LERF are used for external events or shutdown events, if it can be reasonably shown that that the  $\Delta\text{CDF}$  or  $\Delta\text{LERF}$  contribution for external events or shutdown events is less than  $1E-07/\text{yr}$  for CDF and  $1E-08/\text{yr}$  for LERF, the change in CDF/LERF from STI changes for external events or shutdown events need not be considered further.

- b) For a cumulative change in CDF/LERF resulting from all STI changes using SFCP, from a baseline starting point, an acceptance criterion of  $1E-05/\text{yr}$  for CDF and  $1E-06/\text{yr}$  for LERF will apply. In addition, the total CDF must be reasonably shown to be less than  $1E-04/\text{yr}$  when using the  $1E-05/\text{yr}$   $\Delta\text{CDF}$  criterion. Similarly, the total LERF must be reasonably shown to be less than  $1E-05/\text{yr}$  when using the  $1E-06/\text{yr}$   $\Delta\text{LERF}$  criterion. These acceptance criteria are consistent with RG 1.174.

Figure 2 illustrates this process. Steps A and B are performed in parallel to examine the impacts from the internal events PRA model as well as the external events and shutdown PRA models as applicable.

#### **Step 12-A1: Calculate the $\Delta\text{CDF}$ and $\Delta\text{LERF}$ values from the Internal Events PRA**

This step involves exercising the internal events PRA model as addressed in Step 8 or Step 11. The process involves the following:

- Adjust the time-related failure contribution for the all of the components that are uniquely impacted by the STI change. As indicated in Step 8, the time-related failure contribution can be based on recognized data sources or plant-specific data. If neither is available, the total failure probability shall be assumed to be time-related.
- Adjust the common cause failure (CCF) terms for the components that are uniquely impacted by the STI change. Unless justified otherwise, this adjustment shall be proportional to the adjustment made for the independent time-related contributions to the total independent failure probability.
- Re-evaluate the CDF and LERF values based on the revised independent and CCF failure probabilities identified above. Use the revised CDF and LERF values to determine the  $\Delta\text{CDF}$  and  $\Delta\text{LERF}$  values for the contribution from the internal events model in Step 12-A2.

#### **Step 12-B1: $\Delta\text{CDF}$ and $\Delta\text{LERF}$ Insignificant Based on Qualitative Analysis?**

This step involves performing a qualitative assessment of the potential impact on CDF and LERF from external events and shutdown PRAs. The guidance provided in Step 10 for performing qualitative assessments should also be utilized here.

For each contributor (e.g. fire, seismic, shutdown) where it can be qualitatively determined that the net impact of the STI change is negligible, one can proceed to Step 12-A2 without including its contribution to the total CDF and LERF impact. For each contributor where it cannot be qualitatively determined that the net impact of the STI change is negligible, the analyst must proceed to Step B2 to perform a bounding analysis.

#### **Step 12-B2: $\Delta$ CDF and $\Delta$ LERF Below 1E-07/yr CDF and 1E-08/yr LERF from Bounding Analysis?**

This step is entered if in Step 12-B1 when a qualitative determination was not sufficient to establish that the net impact on CDF and LERF is negligible from the STI change. In this case, an initial bounding analysis of the impact from external events and shutdown can be considered. The guidance provided in Step 10b for performing bounding analysis should also be utilized here. Alternatively, the use of conservatively biased external events or shutdown PRA models is also deemed sufficient for this step.

For each contributor (e.g., fire, seismic, shutdown) where conservative or bounding analysis can be utilized to determine that the net impact of the STI change is less than 1E-07/yr for  $\Delta$ CDF and 1E-08/yr for  $\Delta$ LERF, one can proceed to Step A2 without including its contribution to the total CDF and LERF impact. For each contributor where conservative or bounding analysis cannot be utilized to determine that the net impact of the STI change is less than 1E-07/yr for  $\Delta$ CDF and 1E-08/yr for  $\Delta$ LERF, the analyst must proceed to Step B3 to refine the analysis if possible. In any event, any contributors to CDF and LERF from external events or shutdown that do not screen out at Step 12-B1 or 12-B2 shall be included in the total impact assessment in Step 12-A2.

#### **Step 12-B3: $\Delta$ CDF and $\Delta$ LERF Below 1E-06/yr CDF and 1E-07/yr LERF from Refined Analysis?**

This step is entered from Step 12-B2 if conservative or bounding analysis does not show that the net impact of the STI change is less than 1E-07/yr for  $\Delta$ CDF and 1E-08/yr for  $\Delta$ LERF. At this point, refinement to the conservative or bounding analysis may be pursued since the impact will be included in the total impact assessment in Step 12-A2. The degree of margin and the ability to adequately characterize the impact will determine the amount of refinement that is done.

The final  $\Delta$ CDF and  $\Delta$ LERF values calculated from this step must be compared against the criterion of 1E-06/yr for CDF and 1E-07/yr for LERF. If the criteria are met, then the increase in CDF and LERF values calculated in this step must be added to the corresponding other PRA contributors in Step A2. If the CDF and LERF

criteria are not met, then proceed to Step 13 to consider a revised surveillance test interval for re-evaluation in Step 12 or to Step 4 to end the process.

#### **Step 12-A2: Calculate Total Effect on CDF and LERF for Individual STI Change**

This step simply involves summing the  $\Delta$ CDF and  $\Delta$ LERF values determined in Step 12-A1 and in Step 12-B3 (if applicable). These values are utilized to see if the total CDF and LERF change is within RG 1.174 limits of  $1\text{E-}06/\text{yr}$  for CDF and  $1\text{E-}07/\text{yr}$  for LERF.

#### **Step 12-A3: Total Change Below $1\text{E-}06/\text{yr}$ CDF and $1\text{E-}07/\text{yr}$ LERF?**

In Step 12-A3, the total CDF and LERF change from the individual STI change being assessed is compared to RG 1.174 limits for CDF and LERF changes – taken as CDF increase  $< 1\text{E-}06/\text{yr}$  and LERF increase  $< 1\text{E-}07/\text{yr}$ , for this method. If the above RG 1.174 limits are met, then proceed to Step 12-A4 to evaluate the cumulative impact of all STI changes. If the RG 1.174 limits for CDF and LERF changes are not met, proceed to Step 13 to consider a revised surveillance test interval for re-evaluation in Step 12 or to Step 4 to end the process.

#### **Step 12-A4: Cumulative Change Below $1\text{E-}05/\text{yr}$ CDF and $1\text{E-}06/\text{yr}$ LERF?**

In Step 12-A4, the cumulative CDF and LERF change from all of the individual STI changes are compared to the RG 1.174 limits for CDF and LERF changes. This means that the integrated impact of any previously approved changes using this process must be factored into the cumulative change. That is, the cumulative change shall be calculated by including revised failure probabilities due to all STI adjustments<sup>3</sup> approved using the SFCP (not just the sum of the individual assessments). Additionally, the total CDF must be reasonably shown to be less than  $1\text{E-}04/\text{yr}$  when using the  $1\text{E-}05/\text{yr}$   $\Delta$ CDF criterion and the total LERF must be reasonably shown to be less than  $1\text{E-}05/\text{yr}$  when using the  $1\text{E-}06/\text{yr}$   $\Delta$ LERF criterion. If the RG 1.174 limits are met (for both internal and external events at power as well as during shutdown), then proceed to Step 14 to perform sensitivity studies. If the RG 1.174 limits for CDF and LERF changes are not met, proceed to Step 13 to consider a revised surveillance test interval or to Step 4 to end the process.

#### **Step 13: Revise STI Values**

Step 13 is entered when it is determined that the Surveillance Frequency revisions do not meet the RG 1.174 acceptance criterion in Steps 12-A3 or 12-A4, are not supported by sensitivity study results (Step 14), or are not accepted by the IDP (Step 16 or Step 20). The surveillance frequencies are adjusted accordingly and re-evaluated in Step 12.

<sup>3</sup> See Step19 regarding the impact of PRA update on this process.

## Step 14: Perform Sensitivity Studies

Carry out risk sensitivity studies by changing the unavailability terms for PRA basic events that correspond to SSCs being evaluated. As stated in Section 8 of NEI 00-04, the basic events for both random and common cause failure events shall be increased for failure modes impacted by the changes. A factor of three is appropriate as a sensitivity value because it is representative of the change in reliability between a mean value and an upper bound (95th percentile) for typical equipment reliability distributions. For example, for a lognormal distribution the ratio of the 95th percentile to the mean value would be approximately 2.4 for an error factor of 3 and 3.5 for an error factor of 10.

Additional sensitivity cases should also be explored for particular areas of uncertainty associated with any of the significant contributors to the CDF and LERF results or if there are open Gap Analysis items when compared to the ASME Standard Capability Category II that would impact the results of the assessment.

In practice, this means that the following steps shall be performed.

- At a minimum, re-perform all of the  $\Delta$ CDF and  $\Delta$ LERF determinations assuming that the standby failure rate of the basic event impacted by the STI change is 3 times larger than that used in the base case assessment. Simultaneously, adjust the corresponding standby failure contribution to the total common cause contribution by the same factor of three. Compare the revised CDF and LERF results to the RG 1.174 limits. Note that depending on the synergy of the contribution from all of the affected components due to the STI change, the net impact may be more than a factor of three on the calculated  $\Delta$ CDF and  $\Delta$ LERF evaluations.
- Determine if there is an impact from the STI change on the frequency of event initiators (those already included in the PRA and those screened out because of low frequency). For applications in this initiative, potentially significant initiators include valve failure that could lead to interfacing system loss-of-coolant accidents (LOCAs) or to other sequences that fail the containment isolation function. Include sensitivity case results that account for these items if it is determined that they are applicable for the STI change. Compare the revised CDF and LERF results to the RG 1.174 limits.
- Examine the significant contributors to the RG 1.200 delta assessment. From this evaluation, perform the following:
  - Ensure that there is no reliance on post-accident recovery of failed components affected by the STI (e.g. repair or ad-hoc manual actions, such as manually forcing stuck valves to open). However, credit may be taken for procedural implementation of alternative success strategies. If there is reliance on post-accident recovery of failed components affected by the STI,

then re-perform the analysis with no credit taken for these repair or recovery actions. Compare the revised CDF and LERF results to the RG 1.174 limits.

- Ensure that there is not an undue reliance on key assumptions and causes of uncertainty, especially if there are open Gap Analysis items when compared to the ASME Standard Capability Category II that would impact the results of the assessment. If there is an undue reliance on uncertain model boundary conditions or key assumptions and parameters that would not be encompassed in the factor of three sensitivities identified above, then re-perform the analysis with revisions made to the basic event values associated with the identified key causes of uncertainty. Compare the revised CDF and LERF results to the RG 1.174 limits.

If the sensitivity evaluations support the STI changes (i.e., RG 1.174 limits are still met), then go to Step 15. Alternatively, if the sensitivity evaluations show that the changes in CDF and LERF as a result of changes in SSCs being evaluated are not within the acceptance guidelines of RG 1.174, then revised frequencies should be considered (go to Step 13). However, it is acceptable to proceed to Step 15 even if the results of the sensitivity studies are above the limits, provided the base case results are below the limits. At that point, qualitative considerations shall be developed to provide to the IDP to provide confidence that proceeding with the STI change is still acceptable even though sensitivity studies indicate that the change could exceed the RG 1.174 limits for the individual STI change.

Some examples of qualitative considerations that could be utilized to support the STI change even though it may not be supported by the sensitivity studies are listed below.

- There is plant-specific or industry experience available with other components of the same type that indicate that the failure probability will not be impacted by the STI change. In this case, the standby failure probability utilized for the assessment is not representative of real degradation impacts such that the implementation of the standby failure increase in the sensitivity studies is overly conservative.
- The performance of the test causes unavailability time that when factored into the analysis compared to the potential increase in the failure probability offsets the actual risk increase incurred.
- There are other considerations (e.g. there is an increased likelihood of plant trip associated with the performance of the test) that when factored into the analysis compared to the potential increase in the failure probability offsets the actual risk increase incurred.

**Step 15: Summarize Qualitative and Quantitative Assessments and Establish Recommended Monitoring to be Addressed by IDP**

The results from the following qualitative and quantitative assessments are documented and summarized for consideration by the IDP in Step 18:

- The results from the qualitative considerations developed in Step 7.
- The results from the evaluation of the total and cumulative effect on CDF and LERF generated in Step 12.
- The results from the sensitivity studies conducted in Step 14.
- The results from the qualitative and bounding analyses conducted in Step 10a, 10b, and 10c for STI SSCs not modeled in the PRA.
- Recommended monitoring for SSCs.

As an example, an evaluation form is provided in Appendix A as a guide for minimum documentation expectations.

#### **Step 16: IDP Approval or Adjust STI**

This step involves the use of an IDP that is charged with the task of reviewing the proposed STI for both qualitative considerations and the quantitative results.

The qualifications for the IDP members are very similar to the one for the Maintenance Rule. Normally the same IDP/expert panel is used as for the Maintenance Rule implementation. A specialist with experience in surveillance tests and system or component reliability should also be added to the IDP. Details on the qualification of the IDP members are given in NEI 00-04.

If the IDP approves the change, the changes are implemented and documented for future audits by NRC. If the IDP does not approve certain STI adjustments, then the STI value is not revised (in Step 13).

The IDP has additional responsibilities. These relate to making recommendations on the way the revised surveillance intervals are implemented (for instance, a phased implementation), reviewing the cumulative impact of all changes carried out over a period of time, monitoring the impact of changes on failure rates, and documenting the overall process.

An example IDP charter is provided in Appendix B.

#### **Step 17: Document New STI and Implement the Changes**

The STI changes approved by the IDP are documented appropriately and then implemented by revising plant procedures, affected documents, and training the personnel as needed. Essentially, the SFCP process stops here, however, long-term monitoring is still required per Step 18.

### Step 18: Monitoring & Feedback

The purpose of performance monitoring in the SFCP process is twofold. First, performance monitoring should help confirm that no failure mechanisms that are related to the revised surveillance frequencies become important enough to alter the failure rates assumed in the justification of program changes. Second, performance monitoring should, to the extent practicable, ensure that adequate component capability (i.e., margin) exists relative to design-basis conditions so that component-operating characteristics, over time, do not result in reaching a point of insufficient margin before the next scheduled test. Regulatory Guide 1.175 (Ref. 5) provides guidance on performance monitoring when testing under design basis conditions is impracticable.

Two important aspects of performance monitoring are whether the test surveillance frequency is sufficient to provide meaningful data and whether the testing methods, procedures, and analysis are adequately developed to ensure that performance degradation is detected. Component failure rates should not be allowed to rise to unacceptable levels (e.g., significantly higher than the failure rates used to support the change) before detection and corrective action take place.

For acceptance guidelines, monitoring programs need be proposed that are capable of adequately tracking the performance of equipment that, when degraded, could alter the conclusions that were key to supporting the acceptance of revised surveillance frequencies. Monitoring programs should be structured such that SSCs are monitored commensurate with their safety significance. This allows for a reduced level of monitoring of components categorized as having low safety significance.

The performance monitoring process should have the following attributes:

- Enough tests are included to provide meaningful data.
- The test is devised such that incipient degradation can reasonably be expected to be detected.
- The licensee trends appropriate parameters as necessary, to provide reasonable assurance that the component will remain operable over the test interval.

The output of this step is sent to Step 19.

### Step 19: Periodic Re-assessment

The SFCP contains provisions whereby component performance data is fed back periodically into the component test strategy determination (i.e., test interval and methods) process. This would include results of component or train level monitoring and results of Maintenance Rule (or §50.69 monitoring). The results of these periodic re-assessments are fed back to the IDP in Step 20 for evaluation.



Deleted: 3

Deleted: May

Measures should also be in place to identify the need for more emergent program updates (e.g., following a major plant modification or following a significant equipment performance problem). In addition, for a previously extended STI, if two consecutive unsatisfactory performances of the surveillance occur, than an assessment shall be performed to determine if the time interval between performances of the surveillance is a factor in the cause of the unsatisfactory performance of the surveillance. The results of these emergent assessments are presented to the IDP in a more timely manner in Step 20 for evaluation.

Deleted: periodic

Deleted: re-

Deleted: fed back

Part of the periodic re-assessment includes updating of the PRA (see Figure 3). There are two options that exist to incorporate the revised STIs into the base PRA model. Option 1 is to use the original data assumptions that were utilized in performing the initial STI assessment. Option 2 is to utilize data collection and statistical analysis to show that the reliability of the components affected by the STI change has not been impacted, (or has improved), from the revised STI frequency value. It should, however be realized, that depending on the STI frequency value, this latter option could take several years of data collection before statistically meaningful information is available.

Plant PRAs are updated periodically, at a frequency established by the licensee. During the update, the surveillance frequency changes implemented since the previous PRA update will be modeled in the PRA. Specifically, all PRA changes made in Steps 11 and 12 will be modeled in the PRA update. (However, if the SSC associated with the STI change is only evaluated by a qualitative analysis in Step 10a, or by a bounding analysis in Step 10b or Step 10c, then the STI change will not be modeled in the PRA update). If for the updated PRA, the cumulative changes tracked in Step 12-A4 were less than  $1E-06/\text{yr}$  for CDF and less than  $1E-07/\text{yr}$  for LERF, then the cumulative change can be re-baselined to zero for additional cumulative tracking in Step 12-A4 with the updated PRA model for future STI change assessments. (Note these CDF and LERF limits are 10% of the limits used in Step 12-A4). This would eliminate the need to re-perform every STI assessment when it has already been demonstrated that the net impact of the changes to date is very small and it is known that the impacts of the STI change are included in the revised base model(s). If, however, the cumulative changes were above  $1E-06/\text{yr}$  for CDF or  $1E-07/\text{yr}$  for LERF, then the impact of these STI changes shall be kept track of while calculating the cumulative impact of all future STI changes in Step 12-A4 (which would then still be subject to the  $1E-05/\text{yr}$  cumulative  $\Delta\text{CDF}$  and  $1E-06/\text{yr}$  cumulative  $\Delta\text{LERF}$  limits).

The incorporation of the revised STIs into the base PRA model could result in a net increase or decrease in the cumulative values compared to the prior results since it is expected that other changes to the model that are made as part of the periodic update process will have some impact on the net results of the STI changes. Adjustments to the revised STIs are required if the previous conclusions about the CDF and LERF changes are no longer valid.

Deleted: 3

Deleted: May

### Step 20: IDP Reviews & Adjusts STI as Needed

The IDP is responsible for review of performance monitoring results (from Step 19) and attendant re-assessment of the program.

Step 20 is entered from Step 19 where the operating experience feedback following STI change implementation is periodically reviewed, or the results of an emergent assessment warrant review by the IDP, e.g., if it has been determined that the time interval between successive performances of a surveillance is a factor in the cause of two consecutive unsatisfactory performances of the surveillance. In the case of the example, the IDP shall return the STI back to the previously acceptable STI.

Deleted: periodically

Deleted: .

Any changes identified by the IDP are routed to Step 13, or if no adjustments are required, monitoring is continued in accordance with Step 18. Results of periodic reassessment and any changes to an STI resulting from Step 18 (Monitoring and Feedback) and Step 19 (Periodic Re-assessment) are documented in accordance with the SFCP.

Deleted: The IDP would be responsible for periodic review of performance monitoring results (from Step 19) and attendant re-assessment of the program.

Deleted: are routed back to

Deleted: the results

Deleted: SFPC

## 5.0 REFERENCES

1. 10 CFR50.69, “*Risk-Informed Categorization and Treatment of Structures, Systems and Components for Nuclear Power Reactors*,” May 16, 2003.
2. NUMARC 93-01, Rev. 3, “*Industry Guideline for Monitoring the Effectiveness of Maintenance at Nuclear Power Plants*,” NUMARC- (Currently Nuclear Energy Institute), February 2002.
3. Regulatory Guide 1.174, “*An Approach for using Probabilistic Risk Assessment in Risk-Informed Decisions On Plant-Specific Changes to the Licensing Basis*,” Revision 1, US Nuclear Regulatory Commission, November 2002.
4. Regulatory Guide 1.177, “*An Approach for Plant-Specific Risk-Informed Decisionmaking: Technical Specification*,” US Nuclear Regulatory Commission, August 1998.
5. Regulatory Guide 1.175, “*An Approach for Plant-Specific Risk-Informed Decisionmaking: Inservice Testing*,” US Nuclear Regulatory Commission, August 1998.
6. Regulatory Guide RG 1.200 For Trial Use, “*An Approach for Determining the Technical Adequacy of Probabilistic Risk Assessment Results for Risk-Informed Activities*,” US Nuclear Regulatory Commission, February 2004.



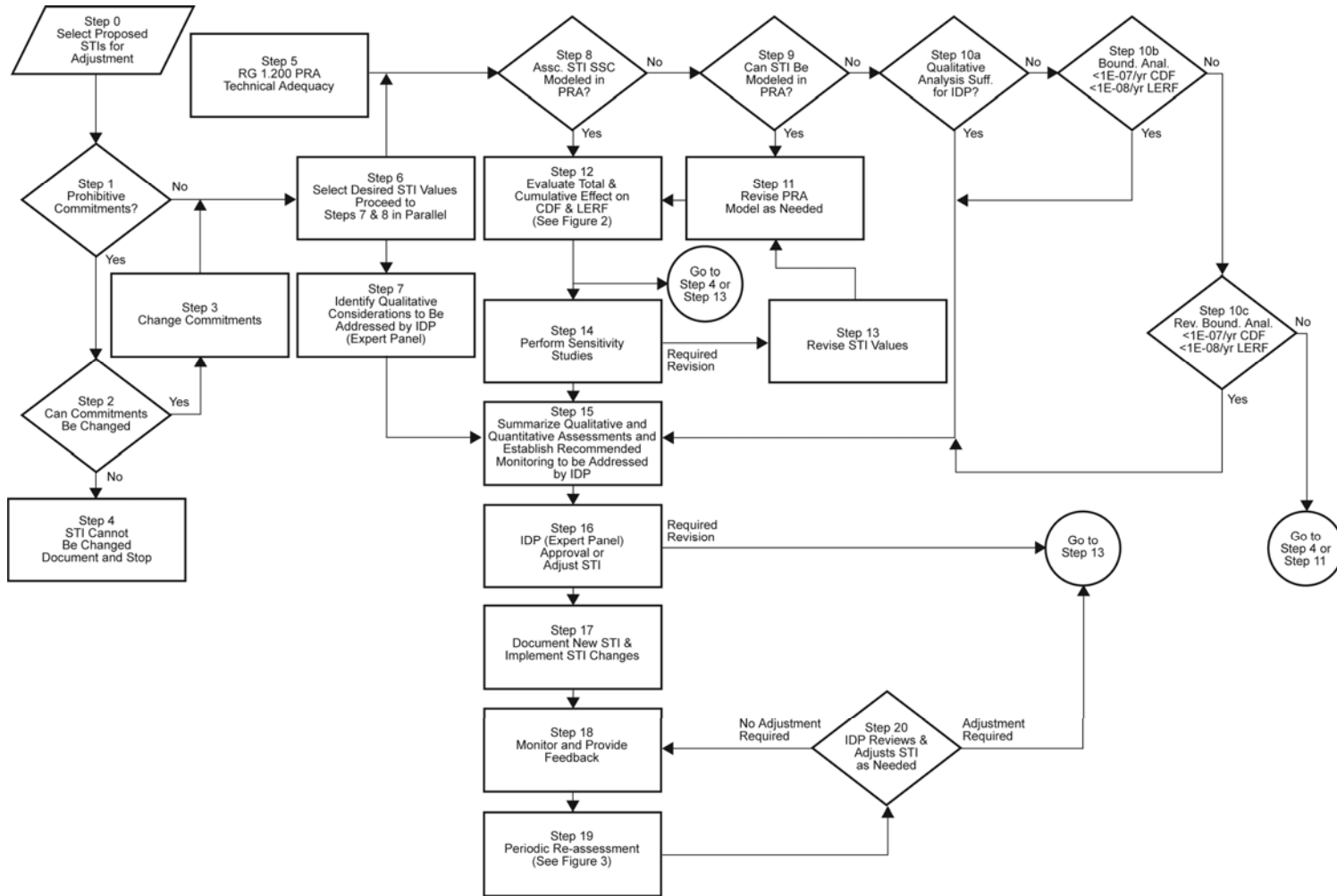

Figure 1. Surveillance Frequency Control Program Change Process

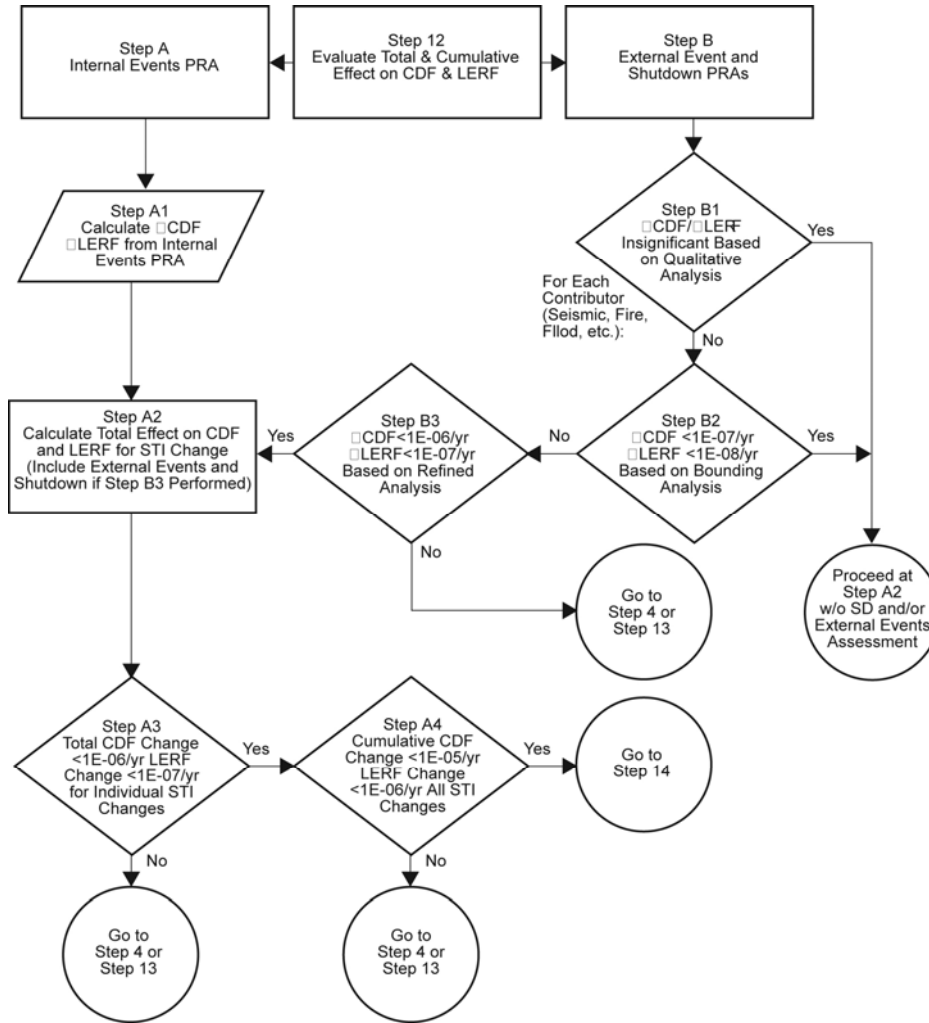
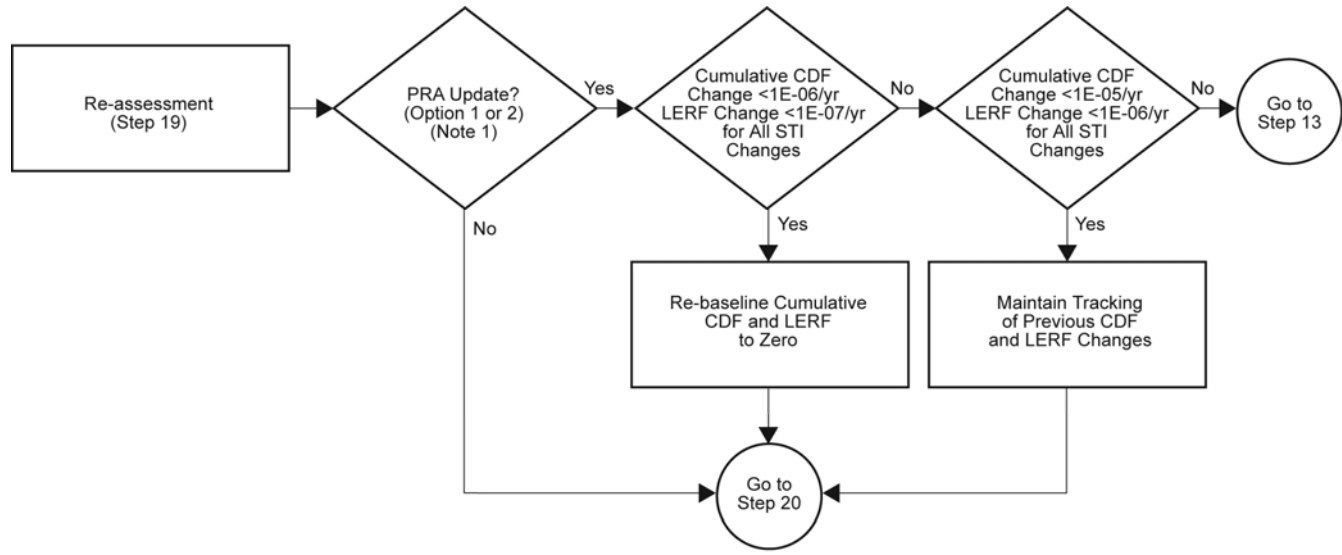

Figure 2. Evaluation of Total and Cumulative Effect on CDF and LERF



Note 1: If the SSC associated with the STI change is only evaluated by a qualitative analysis in Step 10a or by a bounding analysis in Step 10b or Step 10c, then the STI change will not be modeled in the PRA update.

Figure 3. Periodic Re-assessment

**Appendix A**  
**Surveillance Frequency Control Program**

**Sample Surveillance Test Frequency Evaluation Form**



**Surveillance Test Frequency Evaluation**  
 BWROG RITS Initiative 5b Pilot (Ref. TSTF-425)

Procedure # TBD  
 Exhibit 1  
 Page 1 of 5

**Station:** \_\_\_\_\_ **Unit(s):** \_\_\_\_\_  
**Surveillance Test (ST) Number (s):** \_\_\_\_\_ **Revision Number:** \_\_\_\_\_  
**Technical Specification Surveillance Requirement (SR) Number(s):** \_\_\_\_\_  
**Technical Specification SR (Text):** \_\_\_\_\_  
**Technical Specification SR Bases (and Intent):**

\_\_\_\_\_  
 \_\_\_\_\_

**Recommended ST Frequency Change: Adjust ST Frequency (Interval) from** \_\_\_\_ **to** \_\_\_\_  
**Station Benefit:**

**NOTES:**

1: The terms Surveillance Test Interval (STI) and Surveillance Test Frequency are used interchangeably.

A.		SYSTEM INFORMATION
SYSTEM NUMBER: _____		
SYSTEM DESCRIPTION: _____		
B.		QUALITATIVE ANALYSIS:
1	COMMITMENT REVIEW (Is STI credited in any commitments?)	
2	SURVEILLANCE TEST HISTORY OF THE COMPONENTS AND SYSTEM ASSOCIATED WITH THE STI ADJUSTMENT:	
3	RELIABILITY REVIEW: PERFORMANCE (OPERATION & MAINTENANCE) HISTORY OF THE COMPONENTS AND SYSTEM ASSOCIATED WITH THE STI ADJUSTMENT: Maintenance Rule Train Actual Unreliability: _____, Maintenance Rule Unreliability Performance Criteria: _____  Additional PIMS component history review:	
4	UNAVAILABILITY REVIEW: Maintenance Rule Train Actual Unavailability: _____ Maintenance Rule Unavailability Performance Criteria: _____	

**Surveillance Test Frequency Evaluation**  
 BWROG RITS Initiative 5b Pilot (Ref. TSTF-425)

Procedure # TBD  
 Exhibit 1  
 Page 2 of 5

B. QUALITATIVE ANALYSIS:	
5	PAST INDUSTRY AND PLANT-SPECIFIC EXPERIENCE WITH THE FUNCTIONS AFFECTED BY THE PROPOSED CHANGES
6	VENDOR-SPECIFIED MAINTENANCE FREQUENCY
7	ASME AND OTHER CODE-SPECIFIED TEST INTERVAL
8	OTHER QUALITATIVE CONSIDERATIONS (include (a) Comparison to Improved T.S., (b) Alternate ST Test List [retained], (c) LCO Review is optional)
9	IMPACT ON DEFENSE-IN-DEPTH PROTECTION
10	THE IMPACT OF SYSTEMS NOT QUANTIFIED USING THE INTERNAL EVENT PRA
11	THE IMPACT OF SYSTEMS FOR WHICH LERF RESULTS ARE NOT AVAILABLE
12	THE IMPACT OF SYSTEMS FOR WHICH EXTERNAL EVENTS AND SHUTDOWN PRA ARE NOT AVAILABLE
13	UNCERTAINTY ASSOCIATE WIT THE QUANTITATIVE (PRA) PROCESS

**Surveillance Test Frequency Evaluation**  
 BWROG RITS Initiative 5b Pilot (Ref. TSTF-425)

Procedure # TBD  
 Exhibit 1  
 Page 3 of 5

B. QUALITATIVE ANALYSIS:	
14	QUALITATIVE ANALYSIS – CONCLUSIONS
15	PHASED IMPLEMENTATION REQUIREMENTS
16	PROPOSED SURROGATE MONITORING RECOMMENDATIONS: (Consider use of Existing Maintenance Rule monitoring)
17	<p>PREPARES (SECTION B – QUANTITATIVE ANALYSIS – signatures not required):</p> <p>Prepared by: _____ (Subject Matter Expert) Date: _____                      (System Manager or Component Specialist)</p> <p>Prepared by: _____ (PRA input) Date: _____                      (Risk Management Engineer)</p> <p>POST-IDP COMMENT INCORPORATION:</p> <p>Prepared by: _____ (Subject Matter Expert) Date: _____                      (System Manager or Component Specialist)</p> <p>Prepared by: _____ (PRA input) Date: _____                      (Risk Management Engineer)</p>

**Surveillance Test Frequency Evaluation**  
 BWROG RITS Initiative 5b Pilot (Ref. TSTF-425)

Procedure # TBD  
 Exhibit 1  
 Page 4 of 5

C.	PRA (QUANTITATIVE) ANALYSIS	<input type="checkbox"/> Check if not modeled in PRA
1	OVERVIEW OF PRA MODELLING OF STI (include bounding risk analysis techniques if used, and PRA Quality Issues)  Current PRA Model: _____	
2	FULL POWER INTERNAL EVENTS (FPIE) LEVEL 1 PRA MODEL IMPACTS (CDF Comparison against R.G 1.174 limits)	
3	FPIE LEVEL 2 PRA MODEL IMPACTS (LERF Comparison against R.G 1.174 limits)	
4	FIRE RISK IMPACTS (CDF & LERF Comparison against R.G 1.174 limits)	
5	SEISMIC RISK IMPACTS (CDF & LERF Comparison against R.G 1.174 limits)	
6	SHUTDOWN RISKIMPACTS (CDF & LERF Comparison against R.G 1.174 limits)	
7	OTHER PRA ISSUES (ex. Impacts from Other External Events excluding seismic & Fire Risk Impacts)	
8	CUMULATIVE EFFECT OF ALL RI-TS STI ADJUSTMENTS ON INTERNAL, EXTERNAL & SHUTDOWN PRAs. (CDF & LERF Comparison against R.G 1.174 limits)	
9	QUATITATIVE (PRA) ANALYSIS – CONCLUSIONS	
10	PREPARER (SECTION C – PRA [QUANTITATIVE] ANALYSIS – signatures not required) Prepared by: _____ Date _____	

**Surveillance Test Frequency Evaluation**  
 BWROG RITS Initiative 5b Pilot (Ref. TSTF-425)

Procedure # TBD  
 Exhibit 1  
 Page 5 of 5

<b>D</b>	<b>INTEGRATED DECISION-MAKING PANEL (IDP, a/k/a EXPERT PANEL) REVIEW</b>
1	Presenter(s): _____;
2	Meeting Discussion: (Review of Qualitative and Quantitative analyses, and Cumulative Impact)
3	Meeting Results/Recommendations/Bases: (Consider: phased implementation, additional performance monitoring of failure rates) (include comment resolution)
4	<p>Approval/Disapproval: Check one of the following:</p> <p><input type="checkbox"/> STI Approved</p> <p><input type="checkbox"/> STI Approved with Comments</p> <p><input type="checkbox"/> STI Disapproved</p> <p><b>IDP/Expert Panel Members</b></p> <p>1. Engineering Manager* _____</p> <p>2. Maintenance manager* _____</p> <p>3. Operations Manager* _____</p> <p>4. Risk Management (PRA) Engineer* _____</p> <p>5. Maintenance Rule Coordinator* _____</p> <p>6. Surveillance Test Coordinator _____</p> <p>7. System manager or Component Engineer _____</p> <p><b>*Also Maintenance Rule Expert Panel Member</b></p> <p style="text-align: right;">Listing of IDP attendees: (signatures not required – see Maintenance Rule Expert Panel/IDP meeting minutes)</p>
5	IDP/Expert Panel Coordinator Final Review/Closure: (All IDP comments resolved) _____ Date: _____ (IDP Coordinator)

## Appendix B

# Surveillance Frequency Control Program

## Sample Plant IDP Charter

## Sample Plant IDP Charter

### Surveillance Frequency Control Program

#### Overview

The Surveillance Frequency Control Program (SFCP) pursues relocation of STIs from Technical Specifications to a licensee- controlled document such as the Technical Review Manual (TRM). The BWROG and NEI have developed a risk-informed methodology for extending the STI for the relocated tests. The plan is to submit a LAR for relocating the STIs using the methodology developed in NEI 04-10. Plant procedures to support STI implementation will be developed for each individual plant, including a revision to the plant Surveillance Test Program. Procedures are not required to be in effect until the LAR is submitted to the NRC. In the interim, the guideline will govern this process and IDP recommendations will specify the plan for each STI implementation. However, no STI change will be implemented until NRC approval is received.

#### IDP (Integrated Decisionmaking Panel<sup>1</sup>) Requirement

The STI methodology requires review by an IDP.

This charter provides an overview of IDP composition, roles and responsibilities per the guideline.

#### IDP Composition

IDP is comprised of the site MRule (Maintenance Rule) Expert Panel, Surveillance Test Coordinator (STC) and Subject Matter Expert (SME) who is a cognizant system manager or component engineer.

#### IDP Qualifications

- MRule Expert Panel Members: same as MRule Expert Panel qualification.
- Surveillance Test Coordinator (STC): a specialist with experience in surveillance tests.
- Subject Matter Expert (SME): a specialist with experience in system or component reliability.

<sup>1</sup> IDP is a term used in NEI 00-04, "10CFR50.69 SSC Categorization Guideline," Draft Revision D, May 2003, and also US NRC Reg. Guide 1.174, "An Approach for Using PRA and Risk-Informed Decisions on Plant-Specific Changes to the Licensing Basis," July 1998.

#### IDP Roles & Responsibilities

1. Review the guideline Figure 1 and 2 of the SFCP Process (NEI 04-10) to ensure that the flow chart pathway selected by the presenter(s) is correct for the specific STI.
2. Review the quantitative PRA results (if applicable).
3. Review the qualitative considerations associated with STI adjustments. Qualitative considerations include:
  - a) ST and performance history of the components and system associated with the STI adjustment.
  - b) Uncertainty associated with the quantitative process.
  - c) The impact of systems not quantified using the internal event PRA.
  - d) The impact of systems for which LERF results are not available.
  - e) The impact of systems for which external events and shutdown PRA are not available.
  - f) Past industry and plant-specific experience with the functions affected by the proposed changes.
  - g) Impact on defense-in-depth protection.
  - h) Vendor-specified maintenance frequency.
  - i) ASME and other code-specified test intervals.
  - j) Consideration of the impact of a SSC in an adverse or harsh environment.
  - k) Consideration of the benefits of detection at an early stage of potential mechanisms and degradations that can lead to common cause failures.
4. Approval / Disapproval:
  - If the IDP approves the change, the changes will be implemented and documented for future audits by NRC.
  - If the IDP approves the change with comment(s), then the comment(s) will be resolved prior to changes being implemented and documented for future audits by NRC.
  - If the IDP disapproves an STI adjustment, then the STI value is left unchanged.
5. Implementation and monitoring:
  - Consider phased implementation, by determining if the STI change should be implemented in a single step or in phases. Consider phased implementation for risk significant SSCs.
  - Reviewing the cumulative impact of all STI changes carried out over a period of time. (This is also required by NRC risk-informed Reg. Guides 1.174 and 1.177).
  - Monitoring the impact of changes on failure rates.



- a) The IDP can review a previously approved STI adjustment at a future date and reduce it if the performance trend shows increase in the failure rate of components or reduced reliability of the systems.
- b) Since it is not easy to detect changes in failure rate in a short time frame, the IDP should recommend surrogate parameters to be monitored in lieu of the failure rates. Typically, these will be performance indicators, for instance, pump discharge and discharge pressure flow in lieu of pump failure rate and valve opening and closing times in lieu of valve failure rate. Similar monitoring is already being done in response to the Maintenance Rule; it is therefore recommended that this task be added to the same team that carries it out for the Maintenance Rule. Component or train level monitoring would be expected for high risk SSCs. Component failure rates should not be allowed to rise to unacceptable levels (e.g., significantly higher than the failure rates used to support the change) before detection and corrective action take place. The intent of monitoring is to ensure that the component failure rates remain close to those used to support the STI change.
- c) Periodic Review of Performance Monitoring Results and Documentation of the Results from This Review: If the performance of the system, based on the performance indicator monitoring has a degrading trend, then this shall be brought to the attention of the IDP, which would then decide if the STI adjustment should be revised or revoked.
- d) Where there is a very low risk impact from the revised intervals, in general no additional monitoring should be proposed beyond the existing Maintenance Rule performance criteria.