

Draft Submittal
(Pink Paper)

Senior Reactor Operator Written Exam

ST. LUCIE MARCH/APRIL 2006-301 EXAM
05000335/2006301 AND 05000389/2006301
MARCH 20 - 29, 2006 AND APRIL 6, 2006

Examination Outline Cross-reference:	Level	RO	SRO
	Tier #	_____	1
	Group #	_____	1
	K/A #	015 AA2.10	
	Importance Rating	_____	3.7

Ability to determine and interpret the following as they apply to the Reactor Coolant Pump Malfunctions (Loss of RC Flow): When to secure RCPs on loss of cooling or seal injection.

Proposed Question: SRO 76

Given:

- An inadvertent SIAS has occurred on Unit 2.
- While performing the Standard Post Trip Actions you observe annunciator L-6 "RCP CCW FLOW LOW TRIP" is in alarm.

Based on the above conditions what is the required action?

- Stop all operating RCPs per EOP-01, Standard Post Trip Actions.
- Re-establish CCW flow to the RCPs per ARP-01-L6, Annunciator Panel L.
- Verify adequate CCW flow to the RCPs per EOP-01, Standard Post Trip Actions.
- Upon completion of SPTAs inform the Unit Supervisor of the low flow CCW condition per ARP-01-L6, Annunciator Panel L.

Proposed Answer: A

Explanation (Optional):

- Correct.
- Incorrect. This annunciator picks up after 10 minutes, therefore, flow has been lost to the RCPs for > 10 minutes.
- Incorrect. Core Heat Removal acceptance criteria requires RCPs be stopped if CCW is lost for > 10 minutes.
- Incorrect. Core Heat Removal acceptance criteria requires RCPs be stopped if CCW is lost for > 10 minutes.

Technical Reference(s): 2-ARP-01-L6, Annunciator Panel L (Attach if not previously provided)
2-EOP-01 Standard Post Trip Actions

Proposed references to be provided to applicants during examination: _____

Learning Objective: _____ (As available)

Question Source: Bank # 1547
 Modified Bank # _____ (Note changes or attach parent)
 New _____

Question History: Last NRC Exam _____

Question Cognitive Level: Memory or Fundamental Knowledge _____
 Comprehension or Analysis X

10 CFR Part 55 Content: 55.41 _____
 55.43 5

Comments:

REVISION: 0A	PROCEDURE TITLE: ANNUNCIATOR RESPONSE PROCEDURE	PANEL: L
PROCEDURE NO: 2-ARP-01-L6	ST. LUCIE UNIT 2	WINDOW: 6

ANNUNCIATOR PANEL L

1	2	3	4	5	6	7	8
9	10	11	12	13	14	15	16
17	18	19	20	21	22	23	24
25	26	27	28	29	30	31	32
33	34	35	36	37	38	39	40
41	42	43	44	45	46	47	48

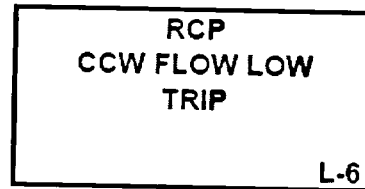

DEVICE:
Module W9P11 K4relay

LOCATION:
RPS Cabinets

SETPOINT:
Less than 1209 to 1231 gpm for
greater than 10 minutes.

ALARM CONFIRMATION:

1. FIS-14-15A to FIS-14-15D, CCW From RCP HX Flow, indicate less than 1220 gpm CCW flow
2. FIS-14-1A or FIS-14-1B, CCW Header Flow, indicate LOW CCW flow.
3. PIS-14-8A or PIS-14-8B, CCW Header Pressure, indicate LOW CCW pressure.
4. 2A, or 2B, or 2C CCW Pump indicate OFF.
5. Any Loss of RCP CCW Trip Unit trip light LIT
6. Annunciator L-14, RCP CCW FLOW LOW 10 MINUTE TIMER STARTED, is alarmed.

OPERATOR ACTIONS:

1. If 2 out of 4 CCW From RCP HX Flow Safety channels are less than 1220 gpm, Then PERFORM the following:
 - A. TRIP the Reactor
 - B. TRIP the Turbine
 - C. GO TO 2-EOP-01, Standard Post Trip Actions
2. If any CCW From RCP HX Flow Safety channel instruments are FAILED, Then IMPLEMENT 2-ONP-99.01, Loss of Tech Spec Instrumentation.

CAUSES: This is caused by low CCW flow from the RCPs, a CCW pump tripped, one of the two CCW headers is ruptured, a loss of instrument air, or a CCW From RCP HX Flow Safety channel instrument is failed.

- REFERENCES:**
1. CWD 2998-B-327 SH 406, 420, 206
 2. TEDB

REVISION NO.: 24	PROCEDURE TITLE: STANDARD POST TRIP ACTIONS ST. LUCIE UNIT 2	PAGE: 10 of 17
PROCEDURE NO.: 2-EOP-01		

4.0 OPERATOR ACTIONS (continued)

CORE HEAT REMOVAL

INSTRUCTIONS	CONTINGENCY ACTIONS
---------------------	----------------------------

5. DETERMINE Core Heat Removal acceptance criteria are met:

<p>A. VERIFY at least ONE RCP is RUNNING and supplied with CCW.</p> <p>B. VERIFY Loop ΔT is less than 10°F.</p>	<p>A.1 If CCW is LOST to the RCPs for greater than 10 minutes, Then STOP ALL RCPs.</p>
--	---

Examination Outline Cross-reference:	Level	RO	SRO
	Tier #		1
	Group #		1
	K/A #	022.AG2.2.22	
	Importance Rating		4.1

Conduct of Operations: Knowledge of limiting conditions for operations and safety limits for loss of Reactor Coolant Makeup.

Proposed Question: SRO 77

Unit 2 is at full power when the following conditions occur:

- Normal Charging flow was lost due to a rupture in Containment downstream of V2429, Charging Pump Disch at Penetration #27 Isolation.
- The alternate Charging flowpath to the RCS through the HPSI header is being aligned.

Which of the following Technical Specification Limiting Conditions for Operation (LCO) is most limiting during this alignment and why?

- LCO 3.0.3, Limiting Conditions for Operation, due to all Charging pumps placed in STOP.
- LCO 3.5 2, Emergency Core Cooling Systems, due to the B HPSI header being *inoperable*.
- LCO 3.1.2.2, Reactivity Control Systems, due to loss of a boron injection flowpath.
- LCO 3.0.3, Containment Systems, due to loss of Containment integrity caused by the rupture.

Proposed Answer: **A**

Explanation (Optional):

- E. Correct. Tech Spec 3.0.3 is applicable when all 3 Charging Pumps are in STOP.
- F. Incorrect. The A HPSI header is *inoperable* when using this alignment. Plausible if the candidate thinks that the B header is used for the alternate charging flowpath.
- G. Incorrect. A boron injection flowpath is not lost during this alignment. Plausible if the candidate thinks that loss of the normal charging flowpath constitutes loss of an injection flowpath.
- H. Incorrect. V2429 will be locked closed during this alignment to meet integrity concerns within 4 hours. Plausible if candidate thinks that the rupture renders the Containment penetration unisolable.

Technical Reference(s): 2-ONP-02.03, Charging and Letdown. (Attach if not previously provided)

Proposed references to be provided to applicants during examination: _____

Learning Objective: _____ (As available)

Question Source: Bank # _____

Modified Bank # _____ (Note changes or attach parent)

New X

Question History: Last NRC Exam _____

Question Cognitive Level: Memory or Fundamental Knowledge X

Comprehension or Analysis _____

10 CFR Part 55 Content: 55.41 10

55.43 _____

Comments:

REVISION NO.: 11A	PROCEDURE TITLE: CHARGING AND LETDOWN	PAGE: 19 of 26
PROCEDURE NO.: 2-ONP-02.03	ST. LUCIE UNIT 2	

APPENDIX B
ALTERNATE CHARGING FLOW PATH TO RCS THROUGH THE A HPSI HEADER
 (Page 5 of 8)

INITIAL

2. If charging flow is lost due to a rupture or component failure upstream of V2429, Charging Pump Disch at Penetr # 27 Isol, Then PERFORM the following:

NOTE
2C Charging Pump will be required to perform this lineup.

A. ENSURE all charging pumps are off. _____

NOTE
Closure of V3656, 2A HPSI pump Discharge valve, will render A HPSI Header inoperable.

B. LOCK CLOSED V3656. _____

CAUTION
When all charging pumps are in the STOP position, Tech Spec 3.0.3 is applicable.

C. PLACE all charging pump control switches to the STOP position while realigning system. _____

Examination Outline Cross-reference:	Level	RO	SRO
	Tier #		1
	Group #		1
	K/A #	040 AG2.4.6	
	Importance Rating		4

Knowledge of symptom based EOP mitigation strategies.

Proposed Question: SRO 78

Unit 1 is in Mode 3 performing a controlled cooldown for a refueling outage with the following conditions:

- RCS Tave 505°F.
- A and B Steam Generator pressure 710 psia.
- RCS pressure 1720 psia.

Immediately after the above conditions were observed, the following occurs:

- RCS pressure, temperature and 1A Steam Generator pressure are falling rapidly.

Which of the following describe the correct procedure to implement?

- 1-EOP-02, Reactor Trip Recovery.
- 1-EOP-03, Loss of Coolant Accident.
- 1-EOP-04, Steam Generator Tube Rupture.
- 1-EOP-05, Excess Steam Demand.

Proposed Answer: D

Explanation (Optional):

- Incorrect. Plausible if candidate thinks that entry into EOP-01 is required when in Mode 3.
- Incorrect. Plausible if candidate thinks a LOCA is in progress due to decreasing RCS pressure.
- Incorrect. Plausible if candidate thinks that SGTR procedure entry is required due to tube leak occurring.
- Correct.

Technical Reference(s): 1-EOP-05 Excess Steam Demand (Attach if not previously provided)

Proposed references to be provided to applicants during examination: _____

Learning Objective: 0702826-09 (As available)

Question Source: Bank # 2186
Modified Bank # _____ (Note changes or attach parent)
New _____

Question History: Last NRC Exam _____

Question Cognitive Level: Memory or Fundamental Knowledge _____
Comprehension or Analysis X

10 CFR Part 55 Content: 55.41 _____
55.43 5

Comments:

REVISION NO.: 22	PROCEDURE TITLE: EXCESS STEAM DEMAND	PAGE: 4 of 39
PROCEDURE NO.: 1-EOP-05	ST. LUCIE UNIT 1	

2.0 ENTRY CONDITIONS

2.1 BOTH of the following conditions exist,

- 1. EITHER** of the following have occurred:
 - 1-EOP-01, Standard Post Trip Actions, have been performed
 - The event initiated from **Mode 3** and SIAS has **NOT** been blocked
- 2. Plant conditions indicate that an ESD has occurred;** **ANY** of the following may be present:
 - Loud noise indicative of a high energy steam line break or stuck open MSSV
 - Lowering RCS T_{AVG} caused by the rise in RCS heat removal
 - Rise in feedwater flow until MFIVs are closed on MSIS
 - Possible rise in Containment temperature, pressure and sump level

Examination Outline Cross-reference:	Level	RO	SRO
	Tier #		1
	Group #		1
	K/A #	057 AG2.1.33	
	Importance Rating		4.0

Ability to recognize indications for system operating parameters which are entry-level conditions for technical specifications (Loss of Vital AC bus)

Proposed Question: SRO 79

Unit 2 is in Mode 1.

Which ONE (1) of the following indications is associated with a loss of 120V AC instrument inverter 2MC and what action is required by Technical Specifications?

- A. Only the "C" train of the "de-energize-to-actuate" ESFAS components will receive an actuation signal, since the trip bistables lost power.
Place affected ESFAS channels in TRIP or BYPASS within 1 hour.
- B. No ESFAS actuation will occur, but all "de-energize-to-actuate" trip bistables on the "C" ESFAS channel will provide a trip signal to the actuation logic.
Place affected ESFAS channels in TRIP or BYPASS within 1 hour.
- C. No ESFAS actuation will occur, since the "C" ESFAS measurement channel and actuation cabinets each have two auctioneered power supplies.
Restore the *inoperable* channel to OPERABLE status within 2 hours.
- D. Both trains of ESFAS components will actuate, two of four logic for SIAS, CIAS, and MSIS will be met for the "C" ESFAS actuation cabinet, due to the power loss.
Restore the *inoperable* channel to OPERABLE status within 2 hours.

Proposed Answer: B

Explanation (Optional):

- A. Incorrect. Plausible if candidate thinks
- B. Correct.
- C. Incorrect. Plausible if candidate thinks
- D. Incorrect. Plausible if candidate thinks

Technical Reference(s): 2-ONP-0970030, 120V Instrument AC System/QSPDS (Attach if not previously provided)
Unit 2 Tech Spec 3.3.1

Proposed references to be provided to applicants during examination: _____

Learning Objective: 0702401-03 (As available)

Question Source: Bank # _____
Modified Bank # 438 (Note changes or attach parent)
New _____

Question History: Last NRC Exam _____

Question Cognitive Level: Memory or Fundamental Knowledge _____
Comprehension or Analysis X

10 CFR Part 55 Content: 55.41 _____
55.43 2, 5

Comments:

Following a loss of 120 VAC instrument inverter 2MA:

the "A" train of the "de-energize-to-actuate" ESFAS components will receive an actuation signal, since the trip bistables lost power.

no ESFAS actuation will occur, but all "de-energize-to-actuate" trip bistables on the "A" ESFAS channel will provide a trip signal to the actuation logic.

nothing will happen to ESFAS since the "A" ESFAS measurement channel and actuation cabinets each have two auctioneered power supplies.

BOTH trains of ESFAS components will actuate, two of four logic for SIAS, CIAS, and MSIS will be met for the "A" ESFAS actuation cabinet, due to the power loss.

REVISION NO.: 14B	PROCEDURE TITLE: 120V INSTRUMENT AC SYSTEM (CLASS 1E) / QSPDS ST. LUCIE UNIT 2	PAGE: 6 of 20
PROCEDURE NO.: 2-0970030		

7.2 Subsequent Operator Actions

INSTRUCTIONS

CONTINGENCY ACTIONS

1. Loss of an Instrument Bus

NOTE

RPS, ESFAS and AFAS will be in a 1 out of 3 logic on loss of one instrument bus and 4 TCBs will be tripped. Table 1 contains a listing of additional instrumentation supplied by the instrument buses.

- A. Ensure plant operating parameters are stable by comparing redundant, non-affected instrumentation.**
- B. Determine which instrument bus has been lost by checking annunciators A-43, B-43, A-53, B-53 and RPS cabinets MA, MB, MC or MD.**

3/4.3 INSTRUMENTATION

3/4.3.1 REACTOR PROTECTIVE INSTRUMENTATION

LIMITING CONDITION FOR OPERATION

3.3.1 As a minimum, the reactor protective instrumentation channels and bypasses of Table 3.3-1 shall be OPERABLE.

APPLICABILITY: As shown in Table 3.3-1.

ACTION:

As shown in Table 3.3-1.

TABLE 3.3-1 (Continued)**ACTION STATEMENTS**

- ACTION 2 - a.** With the number of channels OPERABLE one less than the Total Number of Channels, STARTUP and/or POWER OPERATION may continue provided the inoperable channel is placed in the bypassed or tripped condition within 1 hour. If the inoperable channel is bypassed, the desirability of maintaining this channel in the bypassed condition shall be reviewed in accordance with Specification 6.5.1.6m. The channel shall be returned to OPERABLE status no later than during the next COLD SHUTDOWN.
- b.** With the number of channels OPERABLE one less than the Minimum Channels OPERABLE, STARTUP and/or POWER OPERATION may continue provided the following conditions are satisfied:
1. Verify that one of the inoperable channels has been bypassed and place the other inoperable channel in the tripped condition within 1 hour.
 2. All functional units affected by the bypassed/tripped channel shall also be placed in the bypassed/tripped condition.

With a channel process measurement circuit that affects multiple functional units inoperable or in test, bypass or trip all associated functional units as listed below:

Examination Outline Cross-reference:	Level	RO	SRO
<i>Question TO BE REMOVED!</i>	Tier #	_____	1
	Group #	_____	1
	K/A #	076 AG2.4.1	_____
	Importance Rating	_____	3.3
		_____	_____

Ability to verify system alarm setpoints and operate controls identified in the alarm response manual.

Proposed Question: SRO 80

Unit 1 is raising power from 80% to 100% power. Shortly after reaching 90% the following alarms are received:

- Channel #40, Letdown Gross ratemeter red HIGH alarm light is illuminated.
- Channel #41, Letdown Iodine ratemeter red HIGH alarm light is illuminated.
- Annunciator M-20, LETDOWN RADIATION MONITOR HIGH/FAILURE is in alarm.

(1.) What is the cause of the alarms? and (2.) What action is required?

- A. -A fuel failure is in progress.
-Verify alarm validity then confirm via sampling. Initiate a plant shutdown required by T.S. 3.4.8, RCS Activity
- B. -A high differential pressure (DP) exists across the purification filter.
-Verify local DP indications, and isolate Letdown in accordance with 1-ONP-01.06, Excessive RCS Activity.
- C. -The Purification Ion Exchanger Resin has failed.
-Verify alarm validity then align a properly borated ion exchanger in accordance with 1-ONP-01.06, Excessive RCS Activity.
- D. -A CRUD burst is in progress.
-Verify alarm validity then confirm via sampling. Refer to T.S. 3.4.8 for additional actions

Proposed Answer: **D**

Explanation (Optional):

- A. Incorrect. Partially correct, however, a fuel failure is characterized by increasing iodine levels that remain significantly above prior levels during steady state ops.
- B. Incorrect. Purification filter is parallel to the Letdown radiation monitor. Plausible if candidate thinks that the monitor is downstream.
- C. Incorrect. Ion exchangers are downstream to the Letdown radiation monitor. Plausible if candidate thinks that the monitor is upstream.
- D. Correct. Iodine increase concurrent with a Gross Activity increase during a plant load change is indicative of a crud burst.

Technical Reference(s): 1-ARP-01-M-20, High Letdown Radiation (Attach if not previously provided)

1-ONP-26.01, Process Radiation Monitors

1-ONP-01.06, Excessive RCS Activity

Proposed references to be provided to applicants during examination: _____

Learning Objective: _____ (As available)

Question Source: Bank # _____ Added procedure reference to Distractors.

Modified Bank # _____ (Note changes or attach parent)

New X

Question History: Last NRC Exam _____

Question Cognitive Level: Memory or Fundamental Knowledge _____

Comprehension or Analysis X

10 CFR Part 55 Content: 55.41 _____

55.43 5

Comments:

REVISION: 1	PROCEDURE TITLE: ANNUNCIATOR RESPONSE PROCEDURE	PANEL: M
PROCEDURE NO: 1-ARP-01-M20	ST. LUCIE UNIT 1	WINDOW: 20

ANNUNCIATOR PANEL M

1	2	3	4	5	6	7	8
9	10	11	12	13	14	15	16
17	18	19	20	21	22	23	24
25	26	27	28	29	30	31	32
33	34	35	36	37	38	39	40
41	42	43	44	45	46	47	48

**LETDOWN
RADIATION
MONITOR
HIGH/FAILURE
M-20**

DEVICE:

RY-2202-1
K40A/458
K40C/458
RY-2202-2
K41A/458
K41C/458

LOCATION:

RAB/RAD MNTR PNL
RAB/RAD MNTR PNL
RAB/RAD MNTR PNL
RAB/RAD MNTR PNL

SETPOINT:

De-energized
Energized
De-energized
Energized

ALARM CONFIRMATION:

- Channel #40, Letdown Gross, ratemeter red HIGH alarm light is LIT.
- Channel #40, Letdown Gross, ratemeter blue FAIL light is NOT LIT.
- Channel #41, Ltdn Iodine, ratemeter red HIGH alarm light is LIT.
- Channel #41, Ltdn Iodine, ratemeter blue FAIL light is NOT LIT.
- RR-2202, Process Radiation, Gross Coolant Activity trend increasing (RTGB-105).
- RR-2202, Process Radiation, Selected Isotope trend increasing (RTGB-105).

OPERATOR ACTIONS:

NOTE

- Iodine increase that remains significantly above prior levels during steady state operation is indicative of fuel failure.
- Iodine increase concurrent with a Gross Activity increase during a plant load change is indicative of a crud burst.

- GO TO 1-ONP-26.01, Process Radiation Monitor.

CAUSES: Alarm condition exists when at least **ONE** of the following conditions is met:

- High alarm setpoint reached on Channel #40, Letdown Gross Log Ratemeter
- Failure of Channel #40, Letdown Gross Ratemeter
- High alarm setpoint reached on Channel #41, Ltdn Iodine Ratemeter
- Failure of Channel #41, Ltdn Iodine Ratemeter

REFERENCES

- CWD 8770-B-327 sheet 458
- F&ID 8770-G-078 sheet 120A

REVISION NO.: 3C	PROCEDURE TITLE: PROCESS RADIATION MONITORS	PAGE: 14 of 39
PROCEDURE NO.: 1-ONP-26.01	ST. LUCIE UNIT 1	

4.4 Letdown Monitor

INSTRUCTIONS

CONTINGENCY ACTIONS

- | | |
|---|---|
| <p>1. DETERMINE alarm validity by performing the following:</p> <p>A. DEPRESS and RELEASE the check source (C.S.) button on the affected monitor to ensure the alarm is NOT caused by a stuck check source.</p> <p>B. TEST the CALIBRATE circuit on the affected monitor:</p> <p>1. PLACE the function selector switch to CAL.</p> <p>2. VERIFY the meter responds as expected:</p> <ul style="list-style-type: none"> • Channel 40 – 10⁶ cpm • Channel 41 - .6 cpm (cal) <p>3. PLACE the function selector switch to OPER.</p> <p>C. VERIFY the blue FAIL light is energized, indicating power available and no component failures on the affected monitor.</p> <p>D. VERIFY increased or increasing trend for the affected monitor on RR-2202, Process Radiation</p> <p>2. If a Letdown monitor has malfunctioned, Then NOTIFY I&C.</p> | <p>C.1 If there is a source check malfunction, Then NOTIFY I&C.</p> <p>B.1 If proper response is NOT seen when function switch is placed to CAL, Then NOTIFY I&C.</p> <p>E.1 If the blue FAIL light is NOT energized, Then NOTIFY I&C.</p> |
|---|---|

REVISION NO.: 3C	PROCEDURE TITLE: PROCESS RADIATION MONITORS	PAGE: 15 of 39
PROCEDURE NO.: 1-ONP-26.01	ST. LUCIE UNIT 1	

4.4 Letdown Monitor (continued)

INSTRUCTIONS

CONTINGENCY ACTIONS

NOTE
<ul style="list-style-type: none"> • Iodine increase that remains significantly above prior levels during steady state operation is indicative of fuel failure. • Iodine increase concurrent with a Gross Activity increase during a plant load change is indicative of a crud burst.

3. If the affected monitor is functioning properly and indicates high activity, Then GO TO 1-ONP-01.06, Excessive RCS Activity.

REVISION NO.: 3A	PROCEDURE TITLE: EXCESSIVE RCS ACTIVITY	PAGE: 4 of 8
PROCEDURE NO.: 1-ONP-01.06	ST. LUCIE UNIT 1	

4.0 OPERATOR ACTIONS**4.1 Excessive RCS Activity****INSTRUCTIONS****CONTINGENCY ACTIONS****NOTE**

- ¶1 The decision NOT to derate a unit with a steady state DEQ of 0.75 $\mu\text{Ci/gm}$ or an upward trend of DEQ approaching 0.75 $\mu\text{Ci/gm}$ (unless an identified transient or atypical plant condition temporarily results in this trend), must come from the Site Vice President. The Site Vice President will factor in time to next outage, stability of FPL generation / distribution system and explanation for increasing trends.
- This procedure may contain steps that could adversely affect reactivity. ENSURE that proper consideration and appropriate briefings occur prior to performance of steps that could challenge reactivity.

1. NOTIFY the following of the plant condition:
 - SM
 - Chemistry Supervisor
2. NOTIFY Chemistry to sample RCS gross activity.
3. NOTIFY Health Physics to survey the VCT for a significant increase in radiation levels.
4. When RCS gross activity sample results are obtained, Then COMPARE to previous average RCS sample results.

Examination Outline Cross-reference:	Level	RO	SRO
	Tier #		1
	Group #		1
	K/A #	065 AG2.4.4	
	Importance Rating		4.3

Ability to recognize abnormal indications for system operating parameters which are entry-level conditions for emergency and abnormal operating procedures.

Proposed Question: SRO 81

A Loss of Instrument Air occurs on Unit 1.

The crew has entered ONP-1-1010030, Loss of Instrument Air.

Which ONE (1) of the following describes the response of the CVCS charging and letdown flowpaths, and which of the following actions will be required?

- A. Both charging and the letdown flowpaths will be open; Maintain pressurizer level by starting and stopping charging pumps until instrument air is restored in accordance with ONP-1-1010030, Loss of Instrument Air.
- B. Both charging and the letdown flowpaths will be isolated; Trip the reactor, enter EOP-01, Standard Post Trip Actions.
- C. The charging flow path will be open and the letdown flow path will be isolated; Secure charging until needed and close the letdown isolation valves in accordance with ONP-1-1010030, Loss of Instrument Air.
- D. The charging flow path will be isolated and the letdown flow path will be open; Secure letdown and initiate a plant shutdown to Hot Standby in accordance with 1-GOP-123, Turbine Shutdown – Full Load to Zero Load.

Proposed Answer: C

Explanation (Optional):

- A. Incorrect. Letdown will isolate on both units. Plausible if candidate thinks that letdown remains in service then the action stated would be correct
- B. Incorrect. This action is only required if CCW is lost to the RCPs for > 10 minutes (due to loss of IA). Plausible if candidate thinks that both charging and letdown are lost with CBO continuing to drain the RCS.
- C. Correct. This is correct for either Unit. U1 does not have an air-operated valve upstream of the MOVs and the U2 valve (V2523) fails open. This action prevents inadvertent restoration of letdown.
- D. Incorrect. Unit 1 has no air-operated charging isolation and the letdown valves fail closed. Plausible as this action will maintain pressurizer level.

Technical Reference(s): 2-1010030, Loss of Instrument Air (Attach if not previously provided)

Proposed references to be provided to applicants during examination: _____

Learning Objective: _____ (As available)

Question Source: Bank # 2598
 Modified Bank # _____ (Note changes or attach parent)
 New _____

Question History: Last NRC Exam _____

Question Cognitive Level: Memory or Fundamental Knowledge _____
 Comprehension or Analysis X

10 CFR Part 55 Content: 55.41 _____
 55.43 5

Comments:

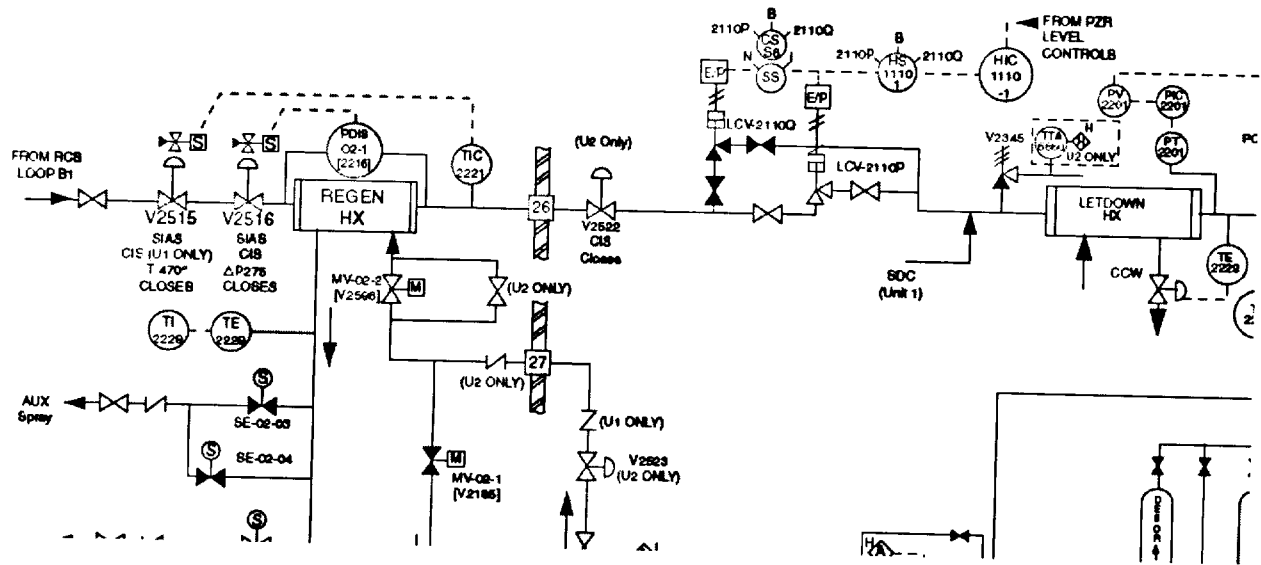

REVISION NO.: 30	PROCEDURE TITLE: LOSS OF INSTRUMENT AIR	PAGE: 14 of 18
PROCEDURE NO.: 1-1010030	ST. LUCIE UNIT 1	

APPENDIX C
AIR ACTUATED COMPONENTS
(Page 1 of 5)

1. Reactor Coolant System

COMPONENT	DESCRIPTION	FAIL POSITION
PCV-1100E	PZR Spray Cntl Vlv from 1B2 RC Loop	Closed
PCV-1100F	PZR Spray Cntl Vlv from 1B1 RC Loop	Closed
1A1 RCP	Upper/Lower Oil Reservoir Level	Indicates low
1A2 RCP	Upper/Lower Oil Reservoir Level	Indicates low
1B1 RCP	Upper/Lower Oil Reservoir Level	Indicates low
1B2 RCP	Upper/Lower Oil Reservoir Level	Indicates low

2. Chemical Volume Control System

COMPONENT	DESCRIPTION	FAIL POSITION
FCV-2161	BAM Pumps Disch Upstrm of Strainer Isol	Closed
LCV-2110P	Letdown Level Cntl	Closed
LCV-2110Q	Letdown Level Cntl	Closed
PCV-2201P	Letdown Press Cntl	Closed
PCV-2201Q	Letdown Press Cntl	Closed
V2500	VCT or Flash Tank from IXS 3-Way Flow Cntl	To VCT
V2505	RCP Bleedoff Hdr Penetr #44 Isol OC	Closed
V2507	RCP Seal Bleedoff to Quench Tank	Closed
V2510	BAM Pumps Recirc to 1A BAMT Flow Cntl	Closed
V2511	BAM Pumps Recirc to 1B BAMT Flow Cntl	Closed
V2521	Letdown RAD Monitor Stop Valve	Closed
V2515	1B1 Ltdn Loop to Regen HX Temp. Cntl	Closed
V2516	1B1 Ltdn Loop to Regen HX Press Cntl	Closed
V2520	Purif IXS & Deborating IX Bypass 3-Way Flow Cntl	Bypass IX
V2513	VCT Vent to VGSH Flow Cntl	Closed
FCV-2210X	PMW to VCT	Closed
FCV-2210Y	BAM Pumps Disch to VCT	Closed
V2512	VCT Inlet from PMW & BAM Flow Cntl	Closed
LT-2206	1A BAM Tank Level	Indicates Low
LT-2208	1B BAM Tank Level	Indicates Low

Examination Outline Cross-reference:	Level	RO	SRO
	Tier #		1
	Group #		2
	K/A #	003 AG2.4.49	
	Importance Rating		4

Ability to perform without reference to procedures those actions that require immediate operation of system components and controls.

Proposed Question: SRO 82

Unit 1 is operating at 100% power (MOC condition) when a dropped CEA on Unit 1 results in the in-core detectors remaining in alarm even after Tref is matched to Tavg.

If four in-core detectors remain in alarm, what, if any, operator action is required per Technical Specifications?

- A. No action is required or recommended since the alarms will clear after the CEA is restored to its normal position.
- B. Reactor power should be maintained at the current value until Reactor Engineering evaluates core conditions using BEACON.
- C. Initiate actions within 15 minutes to reduce the local linear heat rate to within acceptable values within one hour.
- D. The Reactor should be shutdown until Reactor Engineering evaluates why the alarms did not clear is evaluated and corrected.

Proposed Answer: C

Explanation (Optional):

- A. Incorrect. Plausible if candidate thinks that if the alarms were not present prior to the rod dropping then there should be no alarms when the rod is re-positioned.
- B. Incorrect. Plausible if candidate recognizes that the BEACON program will identify power distribution issues associated with the dropped CEA.
- C. Correct. Required by Tech Specs.
- D. Incorrect. Plausible if candidate thinks that the alarms will continue even with the rod re-positioned.

Technical Reference(s): Unit 1 Tech Specs, 3.2.1 (Attach if not previously provided)
1-ONP-0110030, CEA Off-
Normal Operation and
Realignment

Proposed references to be provided to applicants during examination: _____

Learning Objective: 0702204-06 (As available)

Question Source: Bank # 198
Modified Bank # _____ (Note changes or attach parent)
New _____

Question History: Last NRC Exam _____

Question Cognitive Level: Memory or Fundamental Knowledge _____
Comprehension or Analysis X

10 CFR Part 55 Content: 55.41 _____
55.43 2

Comments:

3/4.2 POWER DISTRIBUTION LIMITS

LINEAR HEAT RATE

LIMITING CONDITION FOR OPERATION

3.2.1 The linear heat rate shall not exceed the limits specified in the COLR. |

APPLICABILITY: MODE 1.

ACTION:

With the linear heat rate exceeding its limits, as indicated by four or more coincident incore channels or by the AXIAL SHAPE INDEX outside of the power dependent control limits of COLR Figure 3.2-2, within 15 minutes initiate corrective action to reduce the linear heat rate to within the limits and either: |

- a. Restore the linear heat rate to within its limits within one hour, or
- b. Be in HOT STANDBY within the next 6 hours.

Examination Outline Cross-reference:	Level	RO	SRO
	Tier #		1
	Group #		2
	K/A #	005 AG2.4.50	
	Importance Rating		3.3

Ability to verify system alarm setpoints and operate controls identified in the alarm response manual.

Proposed Question: SRO 83

The following conditions exist on Unit 1:

- Reactor power is 20% during a plant startup.
- Group 7 is being withdrawn at 120 inches when it is noticed that two CEAs in the group have stopped moving.
- Annunciator K-18, CEA POSITION DEVIATION (DCS) is in alarm.
- The CEAs are currently 5 inches lower than the highest CEA in Group 7.
- The two misaligned CEAs are determined to be immovable due to friction

Which ONE (1) of the following actions is required?

- Immediately initiate emergency boration, verify Shutdown Margin within 1 hour, and be in Hot Standby within 6 hours.
- Insert Group 7 CEAs to the position of the stuck CEAs. Restore the stuck CEAs to OPERABLE status within 1 hour or be in Hot Standby within the following 6 hours.
- Maintain power constant while repairing the stuck CEAs. Operation in Mode 1 may continue indefinitely if the remainder of the Group 7 CEAs are within 7.0 inches of the stuck CEAs
- Immediately trip the reactor and ensure the reactor trip breakers are open.

Proposed Answer: A

Explanation (Optional):

- A. Correct.
- B. Incorrect. Plausible if candidate misapplies immovable not due to friction.
- C. Incorrect. Plausible if candidate thinks that the only issue is that the CEA is out of alignment.
- D. Incorrect. Initiating SIAS on Unit 1 does not start an emergency boration. Plausible if candidate thinks that this action will restore SDM.

Technical Reference(s): 1-0110030, CEA Off-Normal Operation and Realignment (Attach if not previously provided)

Proposed references to be provided to applicants during examination: _____

Learning Objective: 0902723-01 (As available)

Question Source: Bank # 1262
Modified Bank # _____ (Note changes or attach parent)
New _____

Question History: Last NRC Exam _____

Question Cognitive Level: Memory or Fundamental Knowledge _____
Comprehension or Analysis X

10 CFR Part 55 Content: 55.41 _____
55.43 2

Comments:

REVISION NO.: 55	PROCEDURE TITLE: CEA OFF-NORMAL OPERATION AND REALIGNMENT ST. LUCIE UNIT 1	PAGE: 12 of 33
PROCEDURE NO.: 1-0110030		

APPENDIX B
ONE OR MORE CEA(S) INOPERABLE
(Page 1 of 2)

1. Ensure the following:
 - A. CEDS in OFF.
 - B. Turbine power adjusted to equal reactor power.
2. Ensure Appendix A "CEA Investigation for Operability" has been performed.

CAUTION

Emergency boration may be required if one CEA is NOT fully inserted and known to be untrippable or immovable due to mechanical interference or excessive friction.

3. §1 With more than one CEA known to be untrippable, or immovable due to excessive friction or mechanical interference immediately commence emergency boration, as per 1-ONP-02.02, Emergency Boration, and be in Hot Standby within six hours, in accordance with 1-ONP-22.01, Rapid Down Power. Ensure adequate shutdown margin, as per 1-OSP-100.14, Surveillance Requirements for Shutdown Margin, Modes 1 and 2 (Critical). (Refer to T.S. 3.1.3.1.a)
4. §1 With one CEA NOT fully inserted and known to be untrippable, or immovable due to excessive friction or mechanical interference, immediately ensure adequate shutdown margin as per 1-OSP-100.14, Surveillance Requirements for Shutdown Margin, Modes 1 and 2 (Critical), and be in Hot Standby within six hours, as per 1-GOP-123, Turbine Shutdown - Full Load to Zero Load. (Refer to T.S. 3.1.3.1.a)
5. §1 With more than one CEA inoperable for reasons other than those stated in Step 3 above, be in Hot Standby within six hours, as per 1-GOP-123, Turbine Shutdown-Full Load to Zero Load. Ensure adequate shutdown margin within one hour, as per 1-OSP-100.14, Surveillance Requirements for Shutdown Margin, Modes 1 and 2 (Critical). (Refer to T.S. 3.1.3.1.c)

Examination Outline Cross-reference:	Level	RO	SRO
	Tier #	_____	1
	Group #	_____	2
	K/A #	032 AA2.04	_____
	Importance Rating	_____	3.5

Ability to determine and interpret the following as they apply to the Loss of Source Range Nuclear Instrumentation: Satisfactory source-range/intermediate-range overlap.

Proposed Question: SRO 84

Given:

- Unit 1 is performing a startup.
- Wide Range Channel "A" fails.
- Repairs are expected to take between 8 and 12 hours.
- Channel "A" was placed in the TRIPPED condition and the startup continued.
- As power is increased above .0001%, the SUR protection verification requirements could not be met for Wide Range Log Safety Channel "D."

What action is required for this condition?

- A. Within one hour, take actions to place Unit 1 in Mode 3.
- B. Place the Channel "D" High Startup Rate in TRIP and continue with the startup.
- C. Repair either Channel "A" or "D" within 48 hours, or be in Mode 3 with the next 6 hours.
- D. Startup may continue as long as reactor power does not exceed 15% until either channel is repaired.

Proposed Answer: A

Explanation (Optional):

- A. Correct.
- B. Incorrect. Applies to Unit 2. Plausible if candidate thinks this applies to both units.
- C. Incorrect. Plausible if candidate thinks that ACTION 2a. is applicable to this condition.
- D. Incorrect. Plausible if candidate thinks SUR is required >15% and not required < 15%.

Technical Reference(s): Unit 1 Tech Spec 3.3.1 (Attach if not previously provided)

Proposed references to be provided to applicants during examination: _____

Learning Objective: _____ (As available)

Question Source: Bank # 1261
 Modified Bank # _____ (Note changes or attach parent)
 New _____

Question History: Last NRC Exam _____

Question Cognitive Level: Memory or Fundamental Knowledge _____
 Comprehension or Analysis X

10 CFR Part 55 Content: 55.41 _____
 55.43 2

Comments:

TABLE 3.3-1 (Continued)
REACTOR PROTECTIVE INSTRUMENTATION

<u>FUNCTIONAL UNIT</u>	<u>TOTAL NO. OF CHANNELS</u>	<u>CHANNELS TO TRIP</u>	<u>MINIMUM CHANNELS OPERABLE</u>	<u>APPLICABLE MODES</u>	<u>ACTION</u>
11. Wide Range Logarithmic Neutron Flux Monitor					
a. Startup and Operating – Rate of Change of Power – High	4	2(d)	3	1, 2 and *	2#
b. Shutdown	4	0	2	3, 4, 5	3
12. Reactor Protection System Logic	4	2	4	1, 2*	4
13. Reactor Trip Breakers	4	2	4	1, 2*	4

ACTION STATEMENTS

- ACTION 1** - With the number of channels OPERABLE one less than required by the Minimum Channels OPERABLE requirement, restore the inoperable channel to OPERABLE status within 48 hours or be in HOT STANDBY within the next 6 hours and/or open the protective system trip breakers.
- ACTION 2** - With the number of OPERABLE channels one less than the Total Number of Channels, STARTUP and/or POWER OPERATION may proceed provided the following conditions are satisfied:
- a. The inoperable channel is placed in either the bypassed or tripped condition within 1 hour. For the purposes of testing and maintenance, the inoperable channel may be bypassed for up to 48 hours from time of initial loss of OPERABILITY; however, the inoperable channel shall then be either restored to OPERABLE status or placed in the tripped condition.

TABLE 3.3-1 (Continued)**ACTION STATEMENTS**

- b. Within one hour, all functional units receiving an input from the inoperable channel are also placed in the same condition (either bypassed or tripped, as applicable) as that required by a. above for the inoperable channel.
- c. The Minimum Channels OPERABLE requirement is met; however, one additional channel may be bypassed for up to 48 hours while performing tests and maintenance on that channel provided the other inoperable channel is placed in the tripped condition.

Examination Outline Cross-reference:	Level	RO	SRO
	Tier #	_____	<u>1</u>
	Group #	_____	<u>2</u>
	K/A #	060 AA2.03	_____
	Importance Rating	_____	<u>3.9</u>

Ability to determine and interpret the following as they apply to Abnormal Plant Evolution: the steps necessary to isolate a given radioactive-gas leak, using P&IDs.

Proposed Question: SRO 85

Given the following:

- Unit 1 is in Mode 4 with a Reactor Coolant System degasification in progress.
- Waste Gas Compressor 1A is in service and aligned to Waste Gas Decay Tank (WGDT) 1B.
 - 1B WGDT pressure is 15 psig.
- Waste Gas Decay Tank 1A was recently filled (< 24 hours ago) and is currently isolated.
 - 1A WGDT pressure is 155 psig.
- Waste Gas Decay Tank 1C has sufficiently decayed (> 6 months) and is currently aligned for release via V6565.
 - 1C WGDT pressure is 150 psig.

Shortly after the release is started the following occurs:

- Annunciator N-38, WASTE GAS DISCH RAD HIGH goes into alarm.
- The SNPO reports WGDT pressures as follows: 1A 140 psig; 1B 20 psig; 1C 140 psig.
- Area radiation levels have remained constant.

What is the cause of the accidental gas release and what action is required to secure the release?

(8770-G-078, Sheet 163A is provided.)

- A.
 1. Waste Gas Compressor 1A is discharging into Waste Gas Decay Tanks 1A, 1B, & 1C.
 2. Ensure the following valves are closed: V6565, V6579, V6597, V6701, V6582, V06825
- B.
 1. Waste Gas Compressor 1A is discharging into Waste Gas Decay Tanks 1A & 1B.
 2. Ensure the following valves are closed: V6565, V6745, V06823, V6579, V6592, V6582
- C.
 1. Waste Gas Decay Tank 1A is cross connected to Waste Gas Decay Tank 1C.
 2. Ensure the following valves are closed: V6565, V6588, V6599, V6584, V6580, V6598
- D.
 1. Waste Gas Decay Tank 1A relief valve is lifting.
 2. Ensure the following valves are closed: V6565, V6547, V6579, V6599, V6588, V6584

Proposed Answer: **C**

Explanation (Optional):

- A. Incorrect. With all three WGDTs cross connected the Waste Gas Compressor will discharge to the tank with the lowest pressure (WGDT B). Plausible if candidate thinks that the WGDT are cross-connected allowing A & C to decrease and B to increase. Proposed alignment does not isolate cross-connected tanks.
- B. Incorrect. This would not cause V6565 to trip on high radiation. Plausible if candidate thinks that when the Waste Gas Compressor is aligned to WGDTs A & B, WGDT A pressure could decrease while the WGDT C pressure rises. Proposed alignment does not isolate tanks.
- C. Correct. Once the release is started, the radiation alarm (due to the short-lived precursors in WGDT A) along with the equalized pressures between WGDTs A & C implies that these two tanks are cross-connected. This alignment effectively isolates WGDT A from WGDT C.
- D. Incorrect. A leaking relief would cause area radiation levels to increase due to leakage past the relief valve stem. Plausible if candidate thinks that the lifting relief will lower the pressure in the A WGDT without causing area radiation levels to rise.

Technical Reference(s): 8770-G-078, Sheet 163A (Attach if not previously provided)

Proposed references to be provided to applicants during examination: 8770-G-078, Sheet 163A

Learning Objective: _____ (As available)

Question Source: Bank # _____
 Modified Bank # _____ (Note changes or attach parent)
 New X

Question History: Last NRC Exam _____

Question Cognitive Level: Memory or Fundamental Knowledge _____
 Comprehension or Analysis X

10 CFR Part 55 Content: 55.41 _____
 55.43 4

Comments:

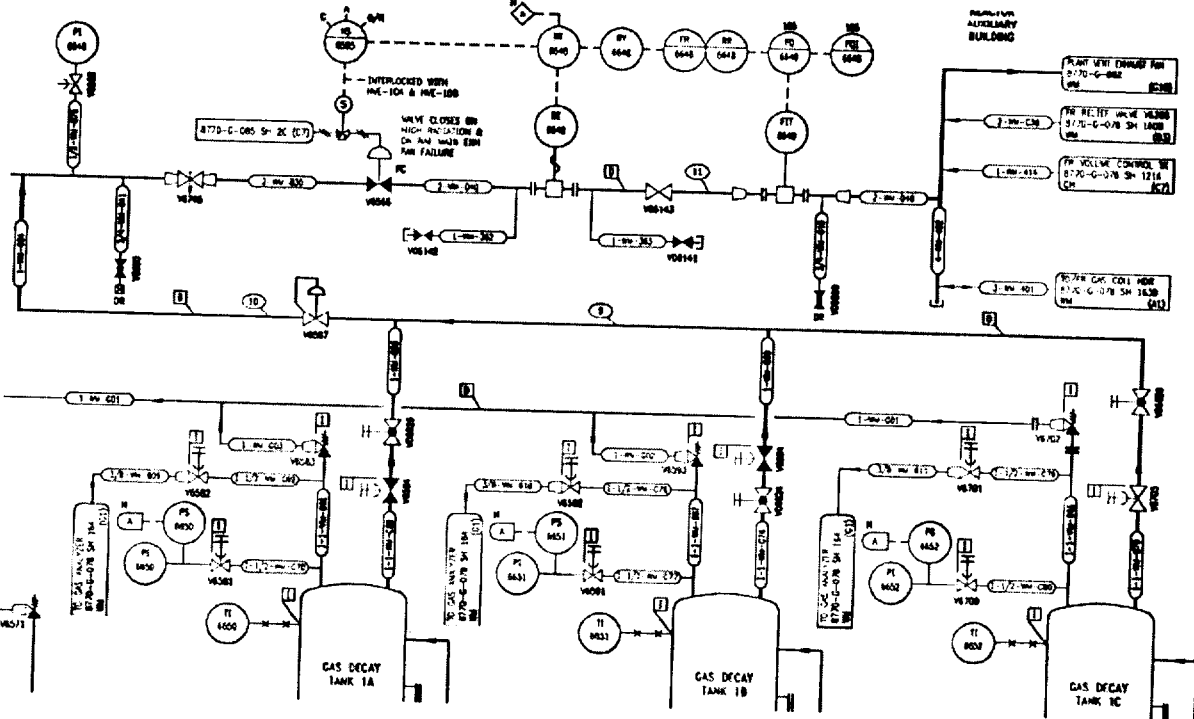
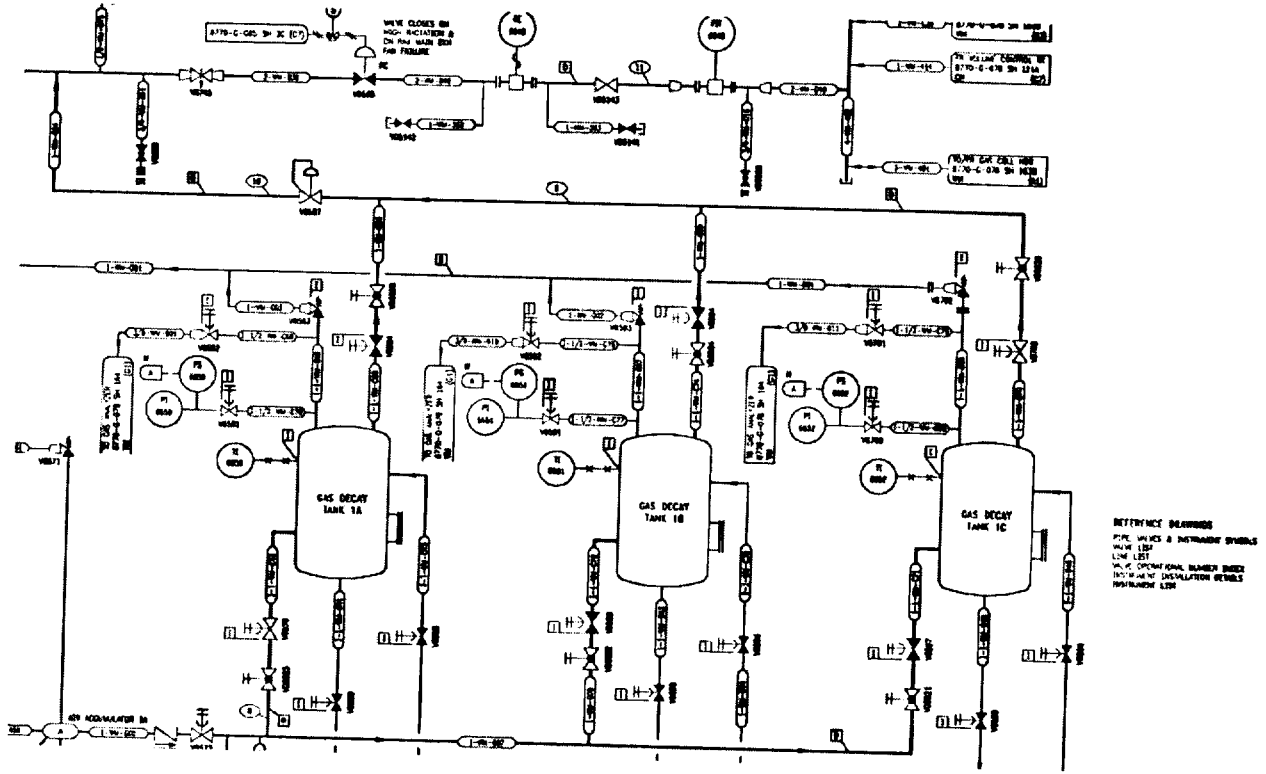

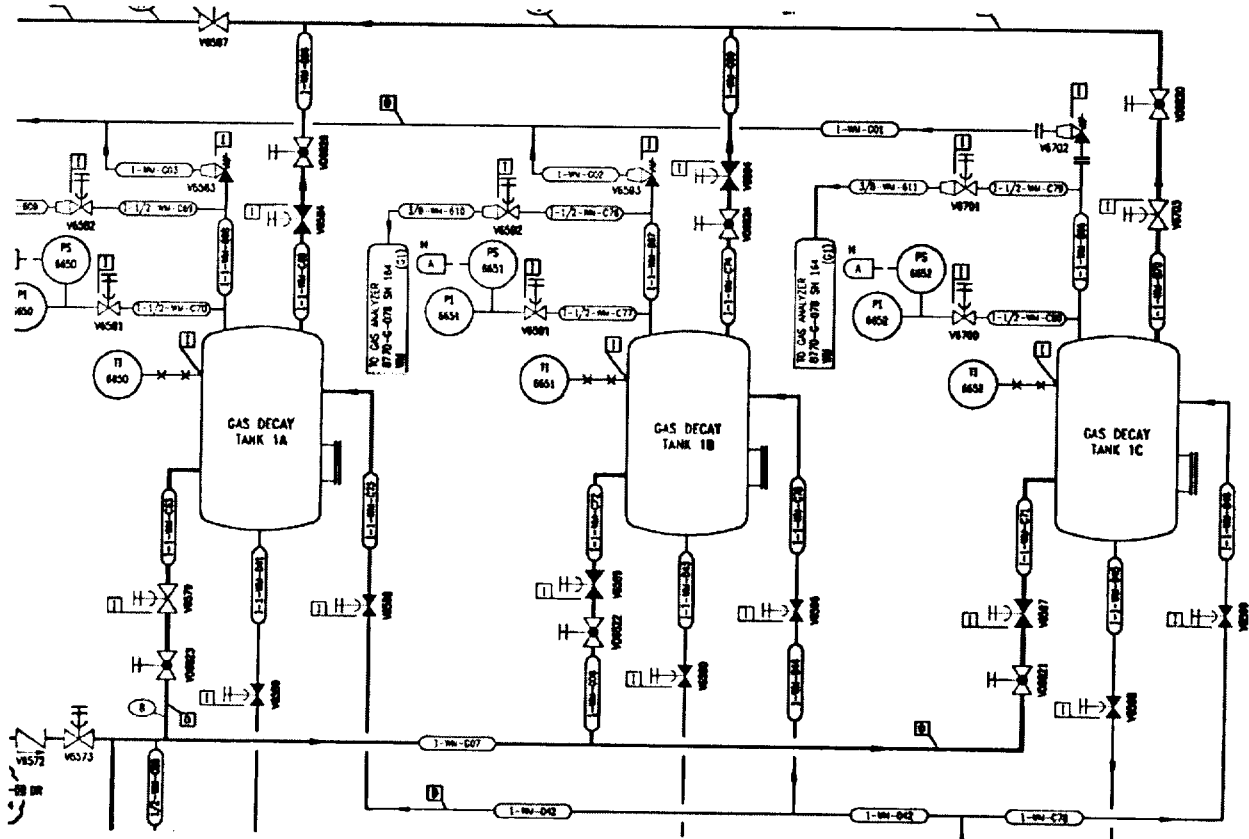

Examination Outline Cross-reference:	Level	RO	SRO
	Tier #	_____	<u>2</u>
	Group #	_____	<u>1</u>
	K/A #	<u>063 A2.01</u>	_____
	Importance Rating	_____	<u>3.2</u>

Ability to (a) predict the impacts of the following on the (SYSTEM) and (b) based on those predictions, use procedures to correct, control, or mitigate the consequences of those abnormal operation .

Proposed Question: SRO 86

During the performance of 2-ONP-50.01, 125V DC Ground Diagnostic Off-Normal procedure you are required to separate 125V DC Bus 2A/2AA from 125V DC Bus 2AB due to ground alarms associated with both buses.

The following equipment is in service:

- Charging Pumps 2A & 2B
- Component Cooling Water Pump 2A & 2B
- Intake Cooling Water Pumps 2A & 2C

What is the status of the 2AB DC Bus and what action is required based on current plant conditions?

- A. It is *inoperable* because no battery is connected to the bus; Place the 2B Intake Cooling Water Pump in service.
- B. It is *inoperable* because the 2AB Battery Charger is a non-qualified battery Charger; Place the 2C Charging Pump in service.
- C. It remains OPERABLE because it is still tied to an operable battery bank; Maintain the current pump configuration until 2-ONP 50.01 is complete.
- D. It remains OPERABLE because the 2AB DC Bus is Class 1E; Align all Train B components to meet Tech Spec LCOs.

Proposed Answer: **A**

Explanation (Optional):

- A. Correct. With the DC buses separated, the 2C ICW Pump does not meet the 2 train requirement for TS 3.7.4.
- B. Incorrect. In this configuration the 2AB bus is not connected to a battery. Plausible if candidate thinks that placing the 2C Charging Pump in service restores proper component alignment.
- C. Incorrect. It is *inoperable* because no battery is connected to the bus. Plausible if candidate thinks the 2AB Bus still retains all sources of power.
- D. Incorrect. Aligning Train B components is correct. Plausible if candidate thinks that aligning the 2B ICW Pump is required.

Technical Reference(s): 2-ONP-50.01 (Attach if not previously provided)

Proposed references to be provided to applicants during examination: _____

Learning Objective: 0702863-08 (As available)

Question Source: Bank # _____
 Modified Bank # 1806 Modified to fit the assigned A2
 K/A by adding 2nd part to Stem.
 New _____

Question History: Last NRC Exam _____

Question Cognitive Level: Memory or Fundamental Knowledge _____
 Comprehension or Analysis X

10 CFR Part 55 Content: 55.41 10
 55.43 _____

Comments:

PLANT SYSTEMS3/4.7.4 INTAKE COOLING WATER SYSTEMLIMITING CONDITION FOR OPERATION

3.7.4 At least two independent intake cooling water loops shall be OPERABLE.*

APPLICABILITY: MODES 1, 2, 3, and 4.

ACTION:

With only one intake cooling water loop OPERABLE, restore at least two loops to OPERABLE status within 72 hours or be in at least HOT STANDBY within the next 6 hours and in COLD SHUTDOWN within the following 30 hours.

SURVEILLANCE REQUIREMENTS

- 4.7.4 At least two intake cooling water loops shall be demonstrated OPERABLE:
- a. At least once per 31 days by verifying that each valve (manual, power-operated, or automatic) servicing safety-related equipment that is not locked, sealed or otherwise secured in position, is in its correct position.
 - b. At least once per 18 months during shutdown, by verifying that each automatic valve servicing safety-related equipment actuates to its correct position on a SIAS test signal.

* When ICW pump 2C is being used to satisfy the requirements of this specification, the alignment of the discharge valves must be verified to be consistent with the appropriate power supply at least once per 24 hours.

Comments: Original question below.

During the performance of the 125V DC Ground Diagnostic Off-Normal procedure you are required to separate 125V DC Bus 2A/2AA from 125V DC Bus 2AB due to ground alarms associated with both buses.

Which of the following is correct concerning the status of the 2AB DC Bus during the time that it is separated from the 2A/2AA DC Bus:

It is inoperable because no battery is connected to the bus.

It is inoperable because the 2AB Battery Charger is a non-qualified battery Charger.

It remains operable because it is still tied to an operable battery bank.

It remains operable because the 2AB DC Bus is Class 1E, Safety Related.

REVISION NO.: 0D	PROCEDURE TITLE: 125V DC GROUND DIAGNOSTIC	PAGE: 9 of 15
PROCEDURE NO.: 2-ONP-50.01	ST. LUCIE UNIT 2	

APPENDIX A
DETERMINATION OF 125V DC BUSES 2A/2AA AND 2AB GROUND LOCATION
(Page 1 of 3)

- INITIAL
1. ENSURE 2AB Battery Charger is in hot standby, in accordance with OP 2-0960020, 125V DC Class 1E Power System Normal Operation. _____
US

<p>CAUTION Separating 125V DC Bus 2A/2AA and 2AB will render Bus 2AB loads inoperable, since no battery is connected to the bus.</p>

2. REFER TO the following Tech Spec sections for LCO and Action requirements:
- Charging Pump 2C, Sections 3.1.2.1, 3.1.2.2, 3.1.2.3 and 3.1.2.4. _____
 - AFW PP 2C, Section 3.7.1.2. _____
 - CCW PP 2C, Section 3.7.3. _____
 - ICW PP 2C, Section 3.7.4. _____
- Separating 125V DC Bus 2A/2AA and 2AB is authorized. _____
US

3. If separating 125V DC Bus 2A/2AA and 2AB is NOT authorized, Then PERFORM BOTH of the following:
- GO TO 2-ONP-50.02, 125V DC Bus 2A/2AA Ground Isolation. _____
 - GO TO 2-ONP-50.04, 125V DC Bus 2AB Ground Isolation. _____

4. VERIFY at least ONE of the following:
- A. Battery Charger 2A is operable. _____
US
- B. Battery Charger 2AA is operable. _____
US

Examination Outline Cross-reference:	Level	RO	SRO
	Tier #	_____	<u>2</u>
	Group #	_____	<u>1</u>
	K/A #	062 A2.05	_____
	Importance Rating	_____	<u>3.3</u>

Ability to (a) predict the impacts of the following malfunctions or operations on the AC Distribution System and (b) based on those predictions, use procedures to correct, control or mitigate the consequences of those abnormal operation: Methods for energizing a dead bus.

Proposed Question: SRO 87

Unit 2 is in a Station Blackout (SBO) condition. Breaker 2-20501, 4.16 KV Bus 2AB Station Blackout Tie Bkr (Unit 2 SBO breaker) failed to close when the RCO attempted to close it using the RTGB control switch.

Which ONE (1) of the following breakers being in the CLOSED position could have caused this situation to occur and what action is required to allow Breaker 2-20501 to close?

- A. 1-20209, Supply from 4.16 KV SWGR 1A2 (1A3 to 1A2 tie);
PLACE Breaker 1-20109, 1A2 to 1A3 Tie in Pull-to-Lock then PLACE SBO Breaker 2-20501 in CLOSE position per ONP-47.01, Loss of a Safety Related AC Bus.
- B. 2-20109, Feeder to 4.16 KV Bus 2A3 (2A2 to 2A3 Tie);
PLACE Breaker 2-20109, Feeder to 4.16 KV Bus (2A2 to 2A3 Tie) in Pull-to-Lock then PLACE SBO Breaker 2-20501 in CLOSE position per EOP-99, Appendices/Figures/Tables/Data Sheets, Appendix V.
- C. 1-20211, Emergency Diesel Generator No. 1A (output breaker);
OPEN Breaker 1-20211, EDG 1A output breaker then PLACE SBO Breaker 2-20501 in CLOSE position per ONP-47.01, Loss of a Safety Related AC Bus.
- D. 2-20211, Emergency Diesel Generator No. 2A (output breaker);
OPEN Breaker 2-20211, EDG 2A output breaker then PLACE SBO Breaker 2-20501 in CLOSE position per EOP-99, Appendices/Figures/Tables/Data Sheets, Appendix V.

Proposed Answer: **D**

Explanation (Optional):

- A. Incorrect. Wrong unit - Unit 2 is in SBO. Plausible as this is the correct breaker on wrong unit and this procedure does not allow recovery using the SBO tie.
- B. Incorrect. The A3 to A2 tie breaker (2-20209) is interlocked. Plausible as this is the opposite breaker on the same tie line and this procedure does allow recovery using the SBO tie.
- C. Incorrect. Does not affect Unit 2. Plausible as this would be correct if Unit 1 was in SBO.
- D. Correct. This is the action and procedure that will allow the SBO breaker to close.

Technical Reference(s): EOP-99, Appendices / Figures / Tables / Data Sheets, Appendix V (Attach if not previously provided)

0711502, AC Distribution SD;
pages 28-29

Proposed references to be provided to applicants during examination: _____

Learning Objective: 0702502-07 (As available)

Question Source: Bank # _____
Modified Bank # 2383 Modified w/ 2nd part to Stem and action to allow the breaker to close. See Comments.
New _____

Question History: Last NRC Exam _____

Question Cognitive Level: Memory or Fundamental Knowledge _____
Comprehension or Analysis X

10 CFR Part 55 Content: 55.41 _____
55.43 5

Comments:

Unit 2 is in an SBO condition. Breaker 2-20501, 4.16 KV Bus 2AB Station Blackout Tie Bkr (U-2 SBO breaker) failed to close when the RCO attempted to close it using the RTGB control switch.

Which one of the following breakers being in the CLOSED position could have caused this situation to occur?

- A. 1-20209, Supply from 4.16 KV SWGR 1A2 (1A3 to 1A2 tie).
- B. 2-20109, Feeder to 4.16 KV Bus 2A3 (2A2 to 2A3 tie).
- C. 1-20211, Emergency Diesel Generator No. 1A (output breaker).
- D. 2-20211, Emergency Diesel Generator No. 2A (output breaker).

REVISION NO.: 30	PROCEDURE TITLE: APPENDICES / FIGURES / TABLES / DATA SHEETS ST. LUCIE UNIT 2	PAGE: 101 of 155
PROCEDURE NO.: 2-EOP-99		

**APPENDIX V
RECEIVING AC POWER FROM UNIT 1 USING SBO CROSSTIE**
(Page 3 of 9)

Section 2: Receiving Power from Unit 1

- 1. When Unit 1 is ready to supply power to Unit 2,
Then PERFORM ALL of the following:
 - A. CLOSE the Unit 2 SBO crosstie breaker, 2AB 4.16 KV BUS SBO TIE (20501).
 - B. REQUEST Unit 1 close their SBO crosstie breaker, 4160V SWGR 1AB UNIT X-TIE BKR (1-20501).
 - C. VERIFY the 2AB 4.16 KV bus has power restored.
- 2. ALIGN the selected train Vital 4.16 KV bus to the 2AB 4.16 KV bus by CLOSING the TWO crosstie breakers:

2AB to 2A3 (√)	2AB to 2B3 (√)
2AB-2A3 (20505) _____	2AB-2B3 (20504) _____
2A3-2AB (20208) _____	2B3-2AB (20409) _____

- 3. VERIFY the selected train Vital 4.16 KV bus has power restored.
- 4. If TWO Unit 1 EDGs are RUNNING,
Then GO TO Section 3, Restoring Loads With TWO Unit 1 EDGs Running.
- 5. If only ONE Unit 1 EDG is RUNNING,
Then GO TO Section 4, Restoring Loads With ONE Unit 1 EDG Running.
- 6. If Unit 1 has Offsite Power,
Then GO TO Section 5, Restoring Loads With Unit 1 Offsite Power.

End of Section 2

Comments: From 0711502, AC Distribution SD; Pages 28-29

STATION BLACKOUT (SBO) BREAKERS

There is a cross-tie connecting the Unit 1 and 2 safety related 4.16 kV AB Buses. It is utilized in the unlikely event of a total loss of off-site power to both St. Lucie Units 1 and 2 and a failure of both emergency diesel generators to start on one unit.

- There are two Station Blackout Breakers; one is utilized on each of the 1AB and 2AB 4.16 kV switchgear. Refer to Figures 1, 2 and 3.
- Both Control Rooms have an annunciator, B1, which alarms if either unit's SBO breaker is closed.

There is a three position switch located on the RTGB of both units. The switch positions are:

- *TRIP* - Trips SBO breaker if the Normal/Isolate switch is in Normal. This is the standard position the switch should be in when system is not in use. Key is removable in this position.
- *NORMAL* - Allows SBO breaker to remain either open or closed. Position for switch after closing SBO breaker. Key is captured.
- *CLOSE* - Closes SBO breaker if Normal/Isolate switch is Normal. Key is captured. Spring returns to Normal.

There are two sets of indicating lights for SBO breaker operation located on each unit's RTGB. They indicate the following:

- Upper green and red lights indicate the position of the other unit's SBO breaker.
- Lower green and red lights indicate the position of *THAT* unit's SBO breaker.
- Amber light indicates that the close permissive is met for either the Unit in SBO or Testing.

Three conditions are possible to make up the close permissive interlock:

- Unit in SBO
- Other Unit in SBO (Does not light the amber light)
- Testing

The actual interlock for each condition is met by:

- Unit in SBO
 - 1) AB 4160V bus undervoltage condition
 - 2) A EDG output breaker open

 - 3) B EDG output breaker open
 - 4) A3 to A2 tie breaker open
 - 5) B3 to B2 tie breaker open
- Other Unit in SBO
 - 1) Other unit's SBO breaker closed (the SBO Unit closes their breaker first)
- Testing
 - 1) AB 4160V bus undervoltage condition
 - 2) AB to A3 tie breaker open
 - 3) AB to B3 tie breaker open

Refer to [Figure 38](#) and [Figure 39](#) for the SBO breaker close permissive logic.

- The SBO cross-tie breakers have Normal/Isolate switches which allow manual operation locally, at the AB 4160V switchgear, or remotely in the Control Room.
- When the SBO breakers are closed, a bus lockout on the AB 4160V bus or an overcurrent condition will trip the associated cross-tie breaker.

Examination Outline Cross-reference:	Level	RO	SRO
	Tier #		2
	Group #		1
	K/A #	006 A2.02	
	Importance Rating		4.3

Ability to (a) predict the impacts of the following malfunctions or operations on the ECCS; and (b), based on those malfunctions, use procedures to correct, control, or mitigate the consequences of those malfunctions or operations: Loss of Flow Path

Proposed Question: SRO 88

Unit 2 has sustained a small break LOCA and EOP-03, Loss of Coolant Accident, has been entered.

All HPSI pumps have TRIPPED and CANNOT be restarted.

Which ONE (1) of the following describes the action required by the CRS?

- A. Continue use of EOP-03 until an alternate procedure is designated by EOP-03 or the Safety Function Status Check, because the Inventory Control Safety Function Status will be UNSAT.
- B. Continue the use of EOP-03 since the event has been diagnosed as a LOCA and all of the Safety Function Status Checks will remain SATISFIED.
- C. Return to the Diagnostic Flowchart in EOP-01, Standard Post Trip Actions; continue in the LOCA procedure since SI Tanks remain available for Inventory Control.
- D. Return to the Diagnostic Flowchart in EOP-01, Standard Post Trip Actions; continue in the LOCA procedure since LPSI remains available for Inventory Control.

Proposed Answer: A

Explanation (Optional):

- A. Correct. Safety Function Status Check will determine which SF must be addressed.
- B. Incorrect. For SBLOCA, HPSI is required. If minimum flow requirements are not met, then must transition to FR procedure
- C. Incorrect. Returning to the diagnostic chart would yield the same transition as it did the first time it was addressed. It is true that SITs are available, but RCS pressure is too high for them to be effective
- D. Incorrect. LPSI available, but will not provide flow during a SBLOCA because RCS pressure is above LPSI shutoff head

Technical Reference(s): EOP-03 SFSC (Attach if not previously provided)

Proposed references to be provided to applicants during examination: _____

Learning Objective: 0702860-08 (As available)

Question Source: Bank # X Changed Distractor B.
 Modified Bank # _____ (Note changes or attach parent)
 New _____

Question History: Last NRC Exam _____

Question Cognitive Level: Memory or Fundamental Knowledge _____
 Comprehension or Analysis X

10 CFR Part 55 Content: 55.41 _____
 55.43 5

Comments: WTSI Bank

REVISION NO.: 24	PROCEDURE TITLE: LOSS OF COOLANT ACCIDENT	PAGE: 60 of 71
PROCEDURE NO.: 2-EOP-03	ST. LUCIE UNIT 2	

ATTACHMENT 1
SAFETY FUNCTION STATUS CHECK SHEET
(Page 4 of 11)

3. RCS INVENTORY CONTROL (continued)

SAFETY FUNCTION	ACCEPTANCE CRITERIA	CHECK <input type="checkbox"/>
--------------------	------------------------	--------------------------------

B. IF HPSI Throttling Criteria NOT Met:

Charging Pumps ALL available running

AND

Safety Injection Flow In accordance with
Figure 2, Safety
Injection Flow vs.
RCS Pressure

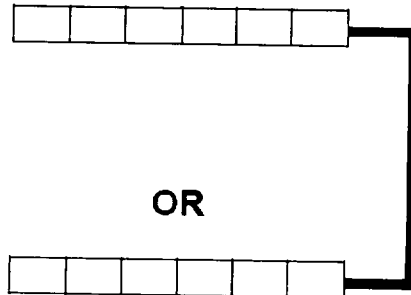

OR

RAS with at least
ONE HPSI Pump
running

REVISION NO.: 30	PROCEDURE TITLE: APPENDICES / FIGURES / TABLES / DATA SHEETS ST. LUCIE UNIT 2	PAGE: 121 of 155
PROCEDURE NO.: 2-EOP-99		

FIGURE 2
SAFETY INJECTION FLOW VS. RCS PRESSURE
(Page 1 of 1)

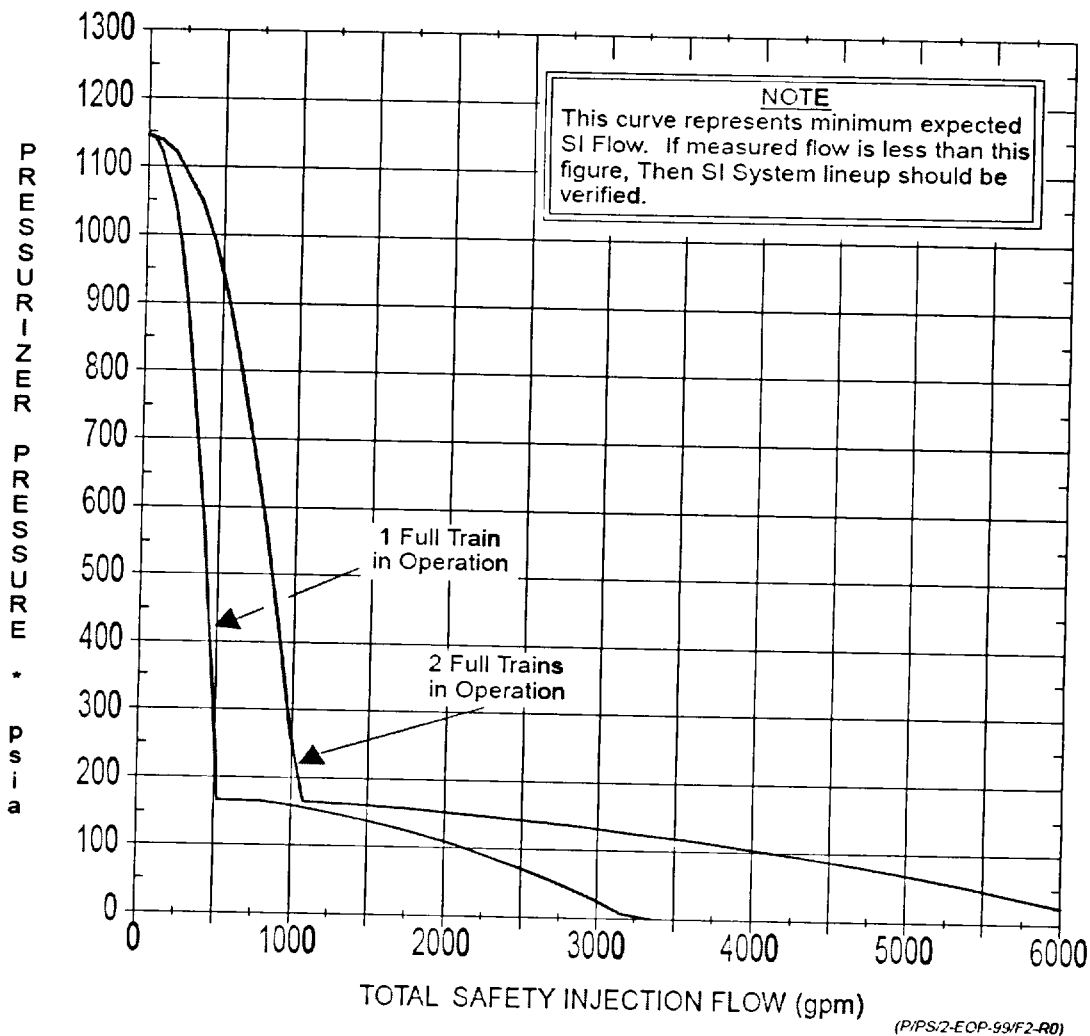

Examination Outline Cross-reference:	Level	RO	SRO
	Tier #		2
	Group #		1
	K/A #	103 G2.1.12	
	Importance Rating		4.0

Ability to apply technical specifications for a system

Proposed Question: SRO 89

Unit 2 is operating at 100% power.

A containment entry is in progress to perform on line maintenance.

The crew entering containment reports that the gasket on the inner air lock door has been damaged. There is a gouge across the entire sealing surface approximately 1/8 inch deep and 1/2 inch wide and they could hear air flow through the gouge before they equalized pressure.

Which ONE (1) of the following actions is required in accordance with Technical Specifications?

- A. Maintain the outer air lock door closed, and within 24 hours lock the outer air lock door closed. Operation may then continue provided that the outer air lock door is verified to be locked closed at least once per 31 days.
- B. Verify that the inner air lock door is closed within 1 hour, and within 24 hours lock the inner air lock door closed. Be in at least Mode 3 within 6 hours and in Mode 5 within the following 30 hours.
- C. Maintain the outer air lock door closed, and within 24 hours lock the outer air lock door closed. Be in Mode 3 within 6 hours and in Mode 5 within the following 30 hours.
- D. Verify that at least the inner air lock door is closed within 1 hour, and within 24 hours lock the inner air lock door closed. Operation may then continue provided that the inner air lock door is verified to be locked closed at least once per 31 days.

Proposed Answer: A

Explanation (Optional):

- A. Correct. Plausible if candidate does not recognize that this is Unit 1. True for Unit 2.
- B. Correct. CIAS only because it is just high radiation.
- C. Incorrect. Plausible if candidate does not recognize that this is Unit 1 and that SIAS gives the CIAS (wrong unit).
- D. Incorrect. Plausible if candidate recognizes the high radiation but also determines that a spray signal is required due to rising pressure.

Technical Reference(s): TS 3.6.3.1 (Attach if not previously provided)

Proposed references to be provided to applicants during examination: _____

Learning Objective: _____ (As available)

Question Source: Bank # X
 Modified Bank # _____ (Note changes or attach parent)
 New _____

Question History: Last NRC Exam _____

Question Cognitive Level: Memory or Fundamental Knowledge _____
 Comprehension or Analysis X

10 CFR Part 55 Content: 55.41 _____
 55.43 2

Comments: WTSI Bank

CONTAINMENT SYSTEMS**CONTAINMENT AIR LOCKS****LIMITING CONDITION FOR OPERATION**

3.6.1.3 Each containment air lock shall be OPERABLE with:

- a. Both doors closed except when the air lock is being used for normal transit entry and exit through the containment, then at least one air lock door shall be closed, and
- b. An overall air lock leakage rate in accordance with the Containment Leakage Rate Testing Program.

APPLICABILITY: MODES 1, 2, 3, and 4.

ACTION:

- a. With one containment air lock door inoperable*:
 1. Maintain at least the OPERABLE air lock door closed and either restore the inoperable air lock door to OPERABLE status within 24 hours or lock the OPERABLE air lock door closed.
 2. Operation may then continue until performance of the next required overall air lock leakage test provided that the OPERABLE air lock door is verified to be locked closed at least once per 31 days.
 3. Otherwise, be in at least HOT STANDBY within the next 6 hours and in COLD SHUTDOWN within the following 30 hours.
 4. The provisions of Specification 3.0.4 are not applicable.
- b. With the containment air lock inoperable, except as the result of an inoperable air lock door, maintain at least one air lock door closed; restore the inoperable air lock to OPERABLE status within 24 hours or be in at least HOT STANDBY within the next 6 hours and in COLD SHUTDOWN within the following 30 hours.

* If the inner air lock door is inoperable, passage through the OPERABLE outer air lock door is permitted to effect repairs to the inoperable inner air lock door. No more than one airlock door shall be open at any time.

Examination Outline Cross-reference:	Level	RO	SRO
	Tier #		2
	Group #		1
	K/A #	064 GG2.1.32	
	Importance Rating		3.8

Ability to explain and apply all system limits and precautions for Emergency Diesel Generators.

Proposed Question: SRO 90

Unit 2 conditions:

- 100% power.
- 2A Diesel Generator (EDG) will be tested in accordance with 2-2200050A, 2A Diesel Generator Periodic Test and General Operating Instructions.

Which ONE (1) of the following correctly describes the status of 2A EDG while paralleled to the grid?

- Operable because it is capable of automatically separating from the grid if emergency loading is required.
- Operable because the 86 relay provides electrical protection against grid problems.
- Inoperable because the Start Circuit Switch (Norm/Isolate #3) is in ISOLATE.
- Inoperable because the LOOP undervoltage relay protection scheme is blocked.

Proposed Answer: D

Explanation (Optional):

- Incorrect. The technical statement is correct but a procedure NOTE specifies that the EDG is inoperable while tied to the grid.
- Incorrect. While it may provide some level of protection, there is no sensing from the grid.
- Incorrect. Switch is only in ISOLATE during the manual roll.
- Correct. The LOOP UV relay protection scheme is blocked while paralleled.

Technical Reference(s): 2-2200050A, 2A Diesel Generator Periodic Test and General Operating Instructions pg. 20, NOTE prior to Step 27 (Attach if not previously provided)

Proposed references to be provided to applicants during examination: _____

Learning Objective: _____ (As available)

Question Source: Bank # _____
Modified Bank # _____ (Note changes or attach parent)
New X

Question History: Last NRC Exam _____

Question Cognitive Level: Memory or Fundamental Knowledge _____
Comprehension or Analysis X

10 CFR Part 55 Content: 55.41 _____
55.43 5

Comments:

REVISION NO.: 68	PROCEDURE TITLE: 2A EMERGENCY DIESEL GENERATOR PERIODIC TEST AND GENERAL OPERATING INSTRUCTIONS ST. LUCIE UNIT 2	PAGE: 20 of 70
PROCEDURE NO.: 2-2200050A		

8.1 Test the 2A Diesel Generator as follows: (continued) INITIAL

25. (continued)

- H.** * Verify the generator obtains 3740 to 4580 volts and 58.8 to 61.2 HZ.

RCO

26. Check the voltage regulator and governor controls for operability:

NOTE

A generator voltage outside the 4000 to 4300 volt range does not render the Diesel Generator inoperable provided the voltage remains within the Technical Specification range of 3740 to 4580 volts. However, it does signify that adjustment of the voltage regulator is required. Notify the System Engineer if the voltage is outside this range.

- A.** Verify the generator steady-state voltage is from 4000 to 4300 volts when the 2A EDG voltage status Amber light is lighted.

RCO

- B.** Make a small change to the manual voltage and governor controls and verify proper response as follows:

- 1.** Adjust the Generator output voltage approximately 200 volts from nominal Generator voltage in both directions (approximately 4000 volts to 4400 volts) using DG Voltage switch to ensure proper operation of the Voltage Regulator.

RCO

- 2.** Adjust the Generator frequency 0.5 Hz from nominal Generator frequency in both directions (approximately 59.5 Hz to 60.5 Hz) using DG Governor switch to ensure proper operation of the Electro-Hydraulic Governor.

RCO

NOTE

When a Diesel Generator is paralleled to the 4.16 KV bus the LOOP undervoltage relay protection scheme is blocked and therefore not available to protect the Diesel Generator from tripping due to a system disturbance. For this reason the Diesel Generator is considered Out of Service during the entire length of time the Diesel Generator is tied to the 4.16 KV bus during surveillance testing.

27. Insert the Sync Plug and place in DG-2A.

RCO

Examination Outline Cross-reference:	Level	RO	SRO
	Tier #	_____	<u>2</u>
	Group #	_____	<u>2</u>
	K/A #	029 A2.04	_____
	Importance Rating	_____	<u>3.2</u>

Ability to (a) predict the impacts of the following on the Containment Purge and (b) based on those predictions, use procedures to correct, control, or mitigate the consequences of those abnormal operations: Health physics sampling of containment atmosphere.

Proposed Question: SRO 91

The following conditions exist on Unit 1:

- Unit is in Mode 3 following a RCP seal failure.
- A batch Containment purge is in progress (<10 hours) using HVE-8A.
- RSC-26-1, Plant Vent Stack Radiation Monitor is in service.
- During the release, Annunciator X-09, NOBLE GAS MULTIPLE INPUT RAD MONITOR ALERT goes into alarm.

While Chemistry is performing a confirmatory grab sample the following alarm is received:

- Annunciator X-15, MULTIPLE INPUT RAD MONITOR FAIL.

What is the probable cause of the alarm and what action, if any, is required when Chemistry confirms increasing radiation in the Primary Vent Stack?

- A. RSC-26-1 noble gas monitor failed low; Close the Containment Purge Outlet Valves FCV-25-4, FCV-25-5, and FCV-25-6 at RTGB-106.
- B. Low pressure as sensed by RSC-26-1; Continue the release until the trip setpoint is reached on RSC-26-1 then secure HVE-8A at RTGB-106.
- C. High or low sample flow as sensed by RSC-26-1; Secure HVE-8A and verify the purge inlet and outlet valves closed at RTGB-106.
- D. RSC-26-1 particulate monitor was stopped; Close the Containment Purge Inlet Valves FCV-25-1, FCV-25-2, and FCV-25-3 at RTGB-106.

Proposed Answer: C

Explanation (Optional):

- A. Incorrect. The noble gas monitor on RSC-26-1 will not bring in the X-15 alarm unless it has been secured for > 10 minutes with 0 cpm. Plausible if candidate thinks the purge will be secured, however, the plant is in Mode 3 and no alternate flowpath exists except through the purge inlet valves.
- B. Incorrect. There is no low pressure component associated with RSC-26-1. Plausible if candidate thinks that opening the grab sample valve creates a low pressure condition and RSC-26-1 will trip the purge fans. Obtaining grab samples is an additional required action.
- C. Correct. This is the most positive action the operator can take to secure the purge.
- D. Incorrect. Closing these valves will eventually trip HVE-8A & 8B when the Containment reaches -4" of water pressure. Plausible if candidate thinks that Chemistry stopped the particulate monitor to obtain the sample which will cause a low sample flow alarm.

Technical Reference(s): 1-OP-0530021, Controlled Gaseous Batch Release to (Attach if not previously provided)

Atmosphere

1-ARP-01-X00, Control Room
Panel X, Radiation Monitor
Panel

1-ONP-26-01, Process
Radiation Monitors; Step
4.8.1.E

Proposed references to be provided to applicants during examination: _____

Learning Objective: _____ (As available)

Question Source: Bank # _____
Modified Bank # _____ (Note changes or attach parent)
New X

Question History: Last NRC Exam _____

Question Cognitive Level: Memory or Fundamental Knowledge _____
Comprehension or Analysis X

10 CFR Part 55 Content: 55.41 11
55.43 _____

Comments:

REVISION NO: 62A	PROCEDURE TITLE: CONTROLLED GASEOUS BATCH RELEASE TO ATMOSPHERE ST. LUCIE UNIT 1	PAGE: 5 of 30
PROCEDURE NO: 1-0530021		
<p>4.14 A containment purge may be terminated at any time by stopping HVE-8A or HVE-8B.</p> <p>4.15 If a gas release is terminated, manually or automatically, due to a valid high radiation alarm a new permit must be obtained before restarting release.</p>		

REVISION: 0A	PROCEDURE TITLE: ANNUNCIATOR RESPONSE PROCEDURE	PANEL: X
PROCEDURE NO: 1-ARP-01-X9	ST. LUCIE UNIT 1	WINDOW: 9

ANNUNCIATOR PANEL X

1	2	3	4	5	6
7	8	9	10	11	12
13	14	15	16	17	

<p align="center">NOBLE GAS MULTIPLE INPUT RAD MONITOR ALERT</p> <p align="right">X-9</p>

DEVICE:

CT#2/355

- (RSC-26-1, Plant Stack)
- (RSC-26-2, ECCS Exh Train A)
- (RSC-26-3, ECCS Exh Train B)
- (RSC-26-4, Fuel Handling Bldg)
- (RE-26-62 A MS)
- (RE-26-63 B MS)

LOCATION:

RAB/RAD MNTR PANEL E

SETPOINT:

Various (IAW Chemistry)

ALARM CONFIRMATION:

1. RCS-26-1 (Plant Stack) ALERT light LIT (CT-1(2) printout).
2. RCS-26-2 (ECCS Exh Train A) ALERT light LIT (CT-1(2) printout).
3. RCS-26-3 (ECCS Exh Train B) ALERT light LIT (CT-1(2) printout).
4. RCS-26-4 (Fuel Handling Bldg) ALERT light LIT (CT-1(2) printout).
5. DAM-3 (Main Steam Lines) ALERT light LIT (CT-1(2) printout).

OPERATOR ACTIONS:

1. DETERMINE which monitor has exceeded the ALERT setpoint.
2. GO TO 1-NOP-26.01, **Process Radiation Monitors**.

CAUSES: Radiation Alert level exists in at least one of the monitored process streams. May result from Fuel Handling accident, leak from a radioactive system to the Containment or RAB atmosphere or a S/G Tube leak contaminating the Main Steam system.

REFERENCES: 1. CWD 8770-B-327 sheets 355, 356 and 359

REVISION: 0B	PROCEDURE TITLE: ANNUNCIATOR RESPONSE PROCEDURE	PANEL: X
PROCEDURE NO: 1-ARP-01-X15	ST. LUCIE UNIT 1	WINDOW: 15

ANNUNCIATOR PANEL X

1	2	3	4	5	6
7	8	9	10	11	12
13	14	15	16	17	

**MULTIPLE INPUT
RAD MONITOR
FAIL**

X-15

DEVICE:

- K6/353 (R-26-56, A CCW)
- K8/353 (R-26-57, B CCW)
- K13/456 (R-6627, Liquid Waste)
- CT#2/355 (RSC-26-1, Plant Stack)
 - (RSC-26-2, ECCS Exh Train A)
 - (RSC-26-3, ECCS Exh Train B)
 - (RSC-26-4, Fuel Handling Bldg)
 - (RE-26-62 A MS)
 - (RE-26-63 B MS)

LOCATION:

- RAB/RAD MNTR PNL E
- RAB/RAD MNTR PNL E
- RAB/RAD MNTR PNL E
- RAB/RAD MNTR PNL E

SETPOINT:

- Deenergized
- Deenergized
- Deenergized
- ONE of the following:**
 - High/Low sample flow
 - >1.2 E^c cpm
 - 0 cpm for >10 minutes
 - Communication error
 - Loss of power

ALARM CONFIRMATION:

1. R-26-56/CCW "A" Channel No. 56 FAIL alarm (PIOPS display)
2. R-26-57/ CCW "B" Channel No. 57 FAIL alarm (PIOPS display)
3. R-6627/Liquid Radwaste Channel No.43 FAIL alarm (PIOPS display)
4. RSC-26-1 (Plant Stack) FAIL (CT-1(2) printout).
5. RSC-26-2 (ECCS Exh Train A) FAIL (CT-1(2) printout).
6. RSC-26-3 (ECCS Exh Train B) FAIL (CT-1(2) printout).
7. RSC-26-4 (Fuel Handling Bldg) FAIL (CT-1(2) printout).
8. DAM-3 (A or B Main Steam) FAIL (CT-1(2) printout).

OPERATOR ACTIONS:

1. DETERMINE which monitor is causing the alarm.
2. If R-6627 is in ALARM, Then GO TO 1-ONP-26.01, Process Radiation Monitors.
3. If R-26-56 or R-26-57, is in ALARM, Then GO TO 1-ONP-26.01, Process Radiation Monitors.

NOTE

LOW FAIL alarm (0 cpm for 10 minutes) on RSC-26-1, RSC-26-2, RCS-26-3 or RCS-26-4 may be an intermittent occurrence due to low background levels. Detector should be considered FAILED when condition exists for two consecutive 10 minute periods.

4. CHECK CT-1(2) terminal to determine status of the affected radiation monitor.
5. REFER TO 1-NOP-26.01, Process Radiation Monitors.

CAUSES: Alarm may be caused by at least **ONE** of the following conditions on R-26-56, R-26-57 or R-6627:

- Low sample flow
- Loss of power

Alarm may also be caused when at least **ONE** of the following conditions exists on an Eberline monitor:

- High or low sample flow
- High or low radiation level
- Communication error
- Loss of power

REFERENCES: 1. CWD 8770-B-327 sheets 355, 353

Examination Outline Cross-reference:	Level	RO	SRO
	Tier #		2
	Group #		2
	K/A #	075 A2.02	
	Importance Rating		2.7

Ability to (a) predict the impacts of the following on the Circulating Water System and (b) based on those predictions, use procedures to correct, control, or mitigate the consequences of those abnormal operations: Loss of circulating water pumps.

Proposed Question: SRO 92

Unit 1 was operating at 60% power. The following conditions exist:

- Seawater temperature is 85°F.
- Condenser $\Delta T = 20^\circ\text{F}$.

A differential current lockout occurs on the 1A2 4.16 KV Bus.

Which ONE (1) of the following statements correctly describes the plant response and the required Unit Supervisor action?

- The 1A and 1B Condenser will lose equal amount of circulating water flow. Trip the unit if condenser backpressure exceeds 5.5 inches of Hg abs.
- The 1A and 1B Condenser will lose equal amount of circulating water flow. Trip the unit if condenser backpressure exceeds 3.5 inches of Hg abs.
- The 1A Condenser will lose all circulating water flow. Trip the unit if high differential pressure between condensers exceeds 2.5 inches of Hg abs.
- The 1A Condenser will lose all circulating water flow. Trip the unit if condenser backpressure exceeds 5.5 inches of Hg abs.

Proposed Answer: **A**

Explanation (Optional):

- A. Correct. The units cannot be maintained on line with only 2 circ water pumps above 30% power. They will have to be tripped when condenser backpressure exceeds 5.5" Hg if power is > 30%.
- B. Incorrect. The units cannot be maintained on line with only 2 circ water pumps above 30% power. 3.5 "Hg is the trip criteria when < 30% power. Plausible if candidate recognizes the unit loses equal amounts of flow to each condenser.
- C. Incorrect. Incorrect: One pump is lost to each condenser - one pump continues to supply flow to each condenser. Plausible if candidate thinks the pumps were lost to one side, the unit would have to be tripped on differential pressure between the A and B side.
- D. Incorrect. One pump is lost to each condenser - one pump continues to supply flow to each condenser. Plausible if candidate thinks the units can be maintained on line with 2 circ water pumps above 30% power.

Technical Reference(s): 1-NOP-21.02, CW System Operation (Attach if not previously provided)

0704201, Cooling Water Systems; page 23

Proposed references to be provided to applicants during examination: _____

Learning Objective: 0704201-03 (As available)

Question Source: Bank # 2395

Modified Bank # _____ (Note changes or attach parent)

New _____

Question History: Last NRC Exam _____

Question Cognitive Level: Memory or Fundamental Knowledge _____

Comprehension or Analysis X

10 CFR Part 55 Content: 55.41 _____

55.43 5

Comments:

REVISION NO.: 1	PROCEDURE TITLE: CIRCULATING WATER SYSTEM OPERATIONS	PAGE: 6 of 64
PROCEDURE NO.: 1-NOP-21.02	ST. LUCIE UNIT 1	
<p>4.10 If vacuum is present in the main condenser, ENSURE the SJAE suction valve for the associated water box is CLOSED PRIOR to securing the CWP. This will prevent an abnormal decrease in main condenser vacuum.</p> <p>4.11 When shutting down Circ Water pumps, allow 60 minutes delay form the time the pump discharge valve is closed prior to securing an additional Circ water pump to allow for discharge canal level to adjust.</p> <p>4.12 If the Circ water pump is being secured due to suspected condenser tube failure, the waterbox may be "quick-drained" by placing the Circ Water pump handswitch on RTGB-102 in the "Pull to Drain" position.</p> <p>4.13 <u>If</u> a Circ Water pump is being secured for water-box cleaning, <u>Then</u> use the slow drain method as described in section 6.6.8.B.</p> <p>4.14 Maximum permissible backpressure for operation at loads less than 30% power is 3.5 inches Hg. Abs. and 5.5 inches Hg. Abs. for loads greater than 30%.</p> <p>4.15 Maximum permissible differential pressure between the condensers is 2.5 inches Hg. Abs.</p> <p>4.16 For steady state operation at loads greater than 30%:</p> <ol style="list-style-type: none"> 1. With four waterboxes in operation: maintain condenser back-pressure less than the low vacuum alarm setpoint, but it SHOULD NOT EXCEED 4.5 inches Hg. Abs. by the average of the two condensers. 2. With less than four waterboxes in operation: reduce turbine load as necessary to maintain less than 4.5 inches Hg. Abs. by the highest indication. <p>4.17 Due to the trip logic for the Circ Water pumps, when starting a Circ Water Pump, wait 10 minutes before securing a different Circ water pump to prevent auto trip of a running pump.</p> <p>4.18 The Debris Filter System (DFS) associated with the Circ water pump should be in operation prior to starting the pump. This includes:</p> <ol style="list-style-type: none"> 1. Bearing Cartridge Lubrication System 2. Differential Pressure Monitoring System 		

Examination Outline Cross-reference:	Level	RO	SRO
	Tier #		2
	Group #		1
	K/A #	041 G2.1.33	
	Importance Rating		4.0

Ability to recognize indications for system operating parameters which are entry level conditions for technical specifications

Proposed Question: SRO 93

Following a plant shutdown, a cooldown using SBCS is in progress.

The following table is a plot of the cooldown:

<u>TIME</u>	<u>RCS T_{COLD}</u>
0800	547°F
0815	523°F
0830	499°F
0845	473°F
0900	449°F
0915	425°F
0930	398°F

Determine whether Tech Spec RCS Cooldown rate limits were exceeded, and if so, at what time were they first exceeded?

- A. Exceeded at 0900.
- B. Exceeded at 0915.
- C. Exceeded at 0930.
- D. Limits were not exceeded.

Proposed Answer: C

Explanation (Optional):

- A. Incorrect. CD Rate was 98.
- B. Incorrect. CD Rate was 98
- C. Correct. CD Rate was 101
- D. Incorrect. Limits were exceeded at 0930

Technical Reference(s): Unit 1 Tech Specs Section 3.4. (Attach if not previously provided)

Proposed references to be provided to applicants during examination: _____

Learning Objective: 0702412-06 (As available)

Question Source: Bank # _____
Modified Bank # _____ (Note changes or attach parent)
New X

Question History: Last NRC Exam _____

Question Cognitive Level: Memory or Fundamental Knowledge _____
Comprehension or Analysis X

10 CFR Part 55 Content: 55.41 _____
55.43 2

Comments:

FIGURE 3-4-4
ST. LUCIE-2 P/T LIMITS, 21.7 EFPY
MAXIMUM ALLOWABLE COOLDOWN RATES

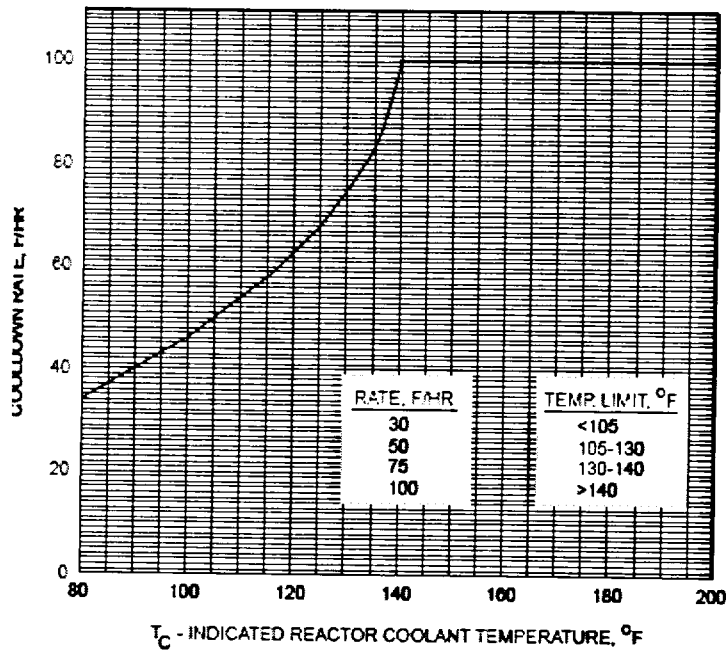

**NOTE: A MAXIMUM COOLDOWN RATE OF
100 F/HR IS ALLOWED AT ANY
TEMPERATURE ABOVE 140°F.**

Examination Outline Cross-reference:	Level	RO	SRO
	Tier #		3
	Group #		1
	K/A #	G2.1.10	
	Importance Rating		3.9

Knowledge of conditions and limitations in the facility license.

Proposed Question: SRO 94

Per 10 CFR 50 and 10 CFR 55, if a licensee develops a permanent physical or mental condition and is unable to perform license duties, the _____ shall be notified within _____ days of learning of the diagnosis.

- A. Medical Review Officer (MRO); 14.
- B. Medical Review Officer (MRO); 30.
- C. Nuclear Regulatory Commission (NRC); 14.
- D. Nuclear Regulatory Commission (NRC); 30.

Proposed Answer: D

Explanation (Optional):

- A. Incorrect. Plausible if candidate thinks that the MRO is involved as theirs is primarily fitness-for-duty related and this involves a FORM 396 to modify the restrictions on an operator's license.
- B. Incorrect. Correct time period to report. Plausible if candidate thinks that the MRO is involved as theirs is primarily fitness-for-duty related.
- C. Incorrect. Plausible if candidate thinks this involves a FORM 396 to modify the restrictions on an operator's license.
- D. Correct.

Technical Reference(s): ADM-18.09, Tracking of Licensed Operators and Licensed Candidates (Attach if not previously provided)

Proposed references to be provided to applicants during examination: _____

Learning Objective: 0702843-06 (As available)

Question Source: Bank # 61
Modified Bank # (Note changes or attach parent)
New

Question History: Last NRC Exam

Question Cognitive Level: Memory or Fundamental Knowledge X
Comprehension or Analysis

10 CFR Part 55 Content: 55.41
55.43 1

Comments:

REVISION NO.: 0C	PROCEDURE TITLE: TRACKING OF LICENSED OPERATORS AND LICENSE CANDIDATES ST. LUCIE PLANT	PAGE: 20 of 44
PROCEDURE NO.: ADM-18.09		

6.5 License Applications (continued)**1. E. (continued)**

- 4.** There is a continued need for a licensee to operate or for a Senior Operator to direct Operators at the facility and the past performance of the licensee has been satisfactory to the Commission.

CAUTION

If during the term of the license, the licensee develops a long term physical or mental condition that causes the licensee to fail to meet the requirements of 10 CFR 55.21, FPL Licensing shall notify the Commission according to 10 CFR 55.25 within 30 days of learning of the diagnosis. For conditions for which a restricted license (as described in 10 CFR 55.33 (b)) is requested, the facility licensee shall provide medical certification on Form 396, Certification of Medical Examination by Facility Licensee.

2. Initial Training Verification Form (a form similar to Appendix D)

- A.** The Training Support Supervisor or designee prepares the Initial Training Verification Form by inserting the current date, the applicant's name, and the date to be returned, allowing approximately 2 weeks.
- B.** Send Training Verification Form to the Operations Initial Training Supervisor for completion.
- C.** Upon receipt of the completed Initial Training Verification Form from the Operations Initial Training Supervisor, ensure that the form is complete with all necessary information. N/A (not applicable) should be indicated where information request does not apply.

3. SRO Upgrade Questionnaire Form (a form similar to Appendix E)

- A.** The following information must be entered by the Training Support Supervisor on the SRO Upgrade Questionnaire Form for each applicant:
- 1.** Date
 - 2.** Applicant's Name (on all pages)
 - 3.** Date to be returned
 - 4.** Training Support Supervisor's Signature

REVISION NO.: 0C	PROCEDURE TITLE: TRACKING OF LICENSED OPERATORS AND LICENSE CANDIDATES ST. LUCIE PLANT	PAGE: 24 of 44
PROCEDURE NO.: ADM-18.09		

6.6 Change in License Status

- 1.** If during a licensed operator annual physical it is determined that a restriction change has occurred, a form 396 must be prepared.
 - A.** Licensed operators attend their scheduled physicals.
 - B.** If there is a change in status, the medical facility notifies the Operations Manager, Operations Supervisor and Training Support Supervisor.
 - C.** The examining physician will determine if the change in status constitutes a restriction to the license as defined by ANSI/ANS 3.4.
 - D.** The Training Support Supervisor will prepare a form 396 if it is determined that there is a restriction change.
 - E.** The licensed operator must comply with any restrictions specified on his / her license.

CAUTION

Failure to notify the NRC as required by 10 CFR 50.74, is a violation. 10 CFR 50.74 requires NRC notification within 30 days when a licensed operator's status changes, as described below:

- Licensed operators who have been permanently removed from the position for which FPL has certified the need for an operator or senior operator license.
- Termination of any licensed individual.
- Disability or illness as described in 10 CFR 55.25.
- Felony conviction as described in 10 CFR 55.53(g).

- 2.** The Licensee's Department Manager shall notify PSL Licensing, within 5 working days any time a Form 106 is filled out transferring a licensee to a position no longer requiring an operator license.
- 3.** PSL Licensing, upon notification by Operations shall notify the NRC and document the notification within thirty (30) days of the change in license status.

END OF SECTION 6.6

Examination Outline Cross-reference:	Level	RO	SRO
	Tier #	_____	3
	Group #	_____	1
	K/A #	G2.1.11	_____
	Importance Rating	_____	3.8

Knowledge of less than one hour technical specification action statements for systems.

Proposed Question: SRO 95

Given the following:

- Unit 2 is in Mode 3.
- RCS pressure is 1800 psia.

Which of the following equipment, if declared *inoperable*, requires Technical Specification ACTION within ONE (1) hour?

- Refueling Water Tank.
- Both 2A and 2C Charging pumps.
- One Main Steam Isolation Valve.
- Both 2A and 2C Intake Cooling water pumps.

Proposed Answer: A

Explanation (Optional):

- Correct. Immediate action required
- Incorrect. 72 hours to restore.
- Incorrect. 4 hours to restore.
- Incorrect. 72 hours to restore.

Technical Reference(s): Unit 2 Tech Spec 3.1.2.8, 3.5.4 (Attach if not previously provided)

Proposed references to be provided to applicants during examination: _____

Learning Objective: _____ (As available)

Question Source: Bank # 2120
 Modified Bank # _____ (Note changes or attach parent)
 New _____

Question History: Last NRC Exam 2002

Question Cognitive Level: Memory or Fundamental Knowledge X
 Comprehension or Analysis _____

10 CFR Part 55 Content: 55.41 10
 55.43 _____

Comments:

Modified Stem from 100% to Mode 3 with a given PZR pressure. Changed Distractor C from 2A & 2B Boric Acid Makeup Tanks to One MSIV.

REACTIVITY CONTROL SYSTEMSBORATED WATER SOURCES – OPERATINGLIMITING CONDITION FOR OPERATION

3.1.2.8 At least two of the following four borated water sources shall be OPERABLE:

- a. Boric Acid Makeup Tank 2A in accordance with Figure 3.1-1.
- b. Boric Acid Makeup Tank 2B in accordance with Figure 3.1-1.
- c. Boric Acid Makeup Tanks 2A and 2B with a minimum combined contained borated water volume in accordance with Figure 3.1-1.
- d. The refueling water tank with:
 1. A minimum contained borated water volume of 417,100 gallons,
 2. A boron concentration of between 1720 and 2100 ppm of boron, and
 3. A solution temperature of between 55°F and 100°F.

APPLICABILITY: MODES 1, 2, 3 and 4.

ACTION:

- a. With the above required boric acid makeup tank(s) inoperable, restore the tank(s) to OPERABLE status within 72 hours or be in at least HOT STANDBY within the next 6 hours and borated to a SHUTDOWN MARGIN equivalent to its COLR limit at 200°F; restore the above required boric acid makeup tank(s) to OPERABLE status within the next 7 days or be in COLD SHUTDOWN within the next 30 hours.
- b. With the refueling water tank inoperable, restore the tank to OPERABLE status within 1 hour or be in at least HOT STANDBY within the next 6 hours and in COLD SHUTDOWN within the following 30 hours.

EMERGENCY CORE COOLING SYSTEMS**3/4.5.4 REFUELING WATER TANK****LIMITING CONDITION FOR OPERATION**

- 3.5.4 The refueling water tank shall be OPERABLE with:
- a. A minimum contained borated water volume 417,100 gallons,
 - b. A boron concentration of between 1720 and 2100 ppm of boron, and
 - c. A solution temperature of between 55°F and 100°F.

APPLICABILITY: MODES 1, 2, 3 and 4.

ACTION:

With the refueling water tank inoperable, restore the tank to OPERABLE status within 1 hour or be in at least HOT STANDBY within 6 hours and in COLD SHUTDOWN within the following 30 hours.

EMERGENCY CORE COOLING SYSTEMS**3/4.5.2 ECCS SUBSYSTEMS - OPERATING****LIMITING CONDITION FOR OPERATION**

- 3.5.2** Two independent Emergency Core Cooling System (ECCS) subsystems shall be OPERABLE with each subsystem comprised of:
- a. One OPERABLE high pressure safety injection pump,
 - b. One OPERABLE low pressure safety injection pump, and
 - c. An independent OPERABLE flow path capable of taking suction from the refueling water tank on a Safety Injection Actuation Signal and automatically transferring suction to the containment sump on a Recirculation Actuation Signal, and
 - d. One OPERABLE charging pump.

APPLICABILITY: MODES 1, 2, and 3*.

ACTION:

- a.
 1. With one ECCS subsystem inoperable only because its associated LPSI train is inoperable, restore the inoperable subsystem to OPERABLE status within 7 days or be in at least HOT STANDBY within the next 6 hours and in HOT SHUTDOWN within the following 6 hours.
 2. With one ECCS subsystem inoperable for reasons other than condition a.1., restore the inoperable subsystem to OPERABLE status within 72 hours or be in at least HOT STANDBY within the next 6 hours and in HOT SHUTDOWN within the following 6 hours.
- b. In the event the ECCS is actuated and injects water into the Reactor Coolant System, a Special Report shall be prepared and submitted to the Commission pursuant to Specification 6.9.2 within 90 days describing the circumstances of the actuation and the total accumulated actuation cycles to date. The current value of the usage factor for each affected safety injection nozzle shall be provided in this Special Report whenever its value exceeds 0.70.

* With pressurizer pressure greater than or equal to 1750 psia.

Examination Outline Cross-reference:	Level	RO	SRO
	Tier #	_____	<u>3</u>
	Group #	_____	<u>2</u>
	K/A #	G2.2.24	_____
	Importance Rating	_____	<u>3.8</u>

Ability to analyze the affect of maintenance activities on LCO status.

Proposed Question: SRO 96

Unit 1 is operating at 100% power. Boric Acid Gravity Valves 1A (V2509) and 1B (V2508) were declared *inoperable* until motor operator modifications to correct a common mode failure issue can be completed.

The following plant conditions exist:

- 1A Charging Pump is out of service for motor replacement.
- 1A Boric Acid Makeup Tank:
 - Level: 6500 gallons
 - Concentration: 5600 ppm boron
- 1B Boric Acid Makeup Tank:
 - Level: 6000 gallons
 - Concentration: 5500 ppm boron

Which statement is correct regarding the Technical Specification required boration flow paths?

The Technical Specification LCO is...

- A. met as two flow paths are available.
- B. met as one flow path is available.
- C. NOT met as only two flow paths are available.
- D. NOT met as only one flow path is available.

Proposed Answer: **A**

Explanation (Optional):

- A. Correct. One flow path available from BAM tank via BAM pump to charging pump, one flow path from RWT via charging pump.
- B. Incorrect. Requires two of the three flow paths available.
- C. Incorrect. Two of the three flow paths are available.
- D. Incorrect. Two of the three flow paths are available.

Technical Reference(s): Unit 1 TS 3.1.2.2; 3.1.2.8 (Attach if not previously provided)

Proposed references to be provided to applicants during examination: Unit 1 TS Fig 3.1-1

Learning Objective: 0702205-11 (As available)

Question Source: Bank # 2085
Modified Bank # _____ (Note changes or attach parent)
New _____

Question History: Last NRC Exam _____

Question Cognitive Level: Memory or Fundamental Knowledge _____
Comprehension or Analysis X

10 CFR Part 55 Content: 55.41 10
55.43 _____

Comments:

REACTIVITY CONTROL SYSTEMS**FLOW PATHS – OPERATING****LIMITING CONDITION FOR OPERATION**

3.1.2.2 At least two of the following three boron injection flow paths shall be OPERABLE:

- a. One flow path from the boric acid makeup tank(s) with the tank meeting Specification 3.1.2.8 part a) or b), via a boric acid makeup pump through a charging pump to the Reactor Coolant System.
- b. One flow path from the boric acid makeup tank(s) with the tank meeting Specification 3.1.2.8 part a) or b), via a gravity feed valve through a charging pump to the Reactor Coolant System.
- c. The flow path from the refueling water storage tank via a charging pump to the Reactor Coolant System.

OR

At least two of the following three boron injection flow paths shall be OPERABLE:

- a. One flow path from each boric acid makeup tank with the combined tank contents meeting Specification 3.1.2.8 c), via both boric acid makeup pumps through a charging pump to the Reactor Coolant System.
- b. One flow path from each boric acid makeup tank with the combined tank contents meeting Specification 3.1.2.8 c), via both gravity feed valves through a charging pump to the Reactor Coolant System.
- c. The flow path from the refueling water storage tank, via a charging pump to the Reactor Coolant System.

APPLICABILITY: MODES 1, 2, 3 and 4.

REACTIVITY CONTROL SYSTEMS**BORATED WATER SOURCES – OPERATING****LIMITING CONDITION FOR OPERATION**

3.1.2.8 At least two of the following four borated water sources shall be OPERABLE:

- a. Boric Acid Makeup Tank 1A in accordance with Figure 3.1-1.
- b. Boric Acid Makeup Tank 1B in accordance with Figure 3.1-1.
- c. Boric Acid Makeup Tanks 1A and 1B with a minimum combined contained borated water volume in accordance with Figure 3.1-1.
- d. The refueling water tank with:
 1. A minimum contained volume of 401,800 gallons of water,
 2. A minimum boron concentration of 1720 ppm,
 3. A maximum solution temperature of 100°F,
 4. A minimum solution temperature of 55°F when in MODES 1 and 2, and
 5. A minimum solution temperature of 40°F when in MODES 3 and 4.

APPLICABILITY: MODES 1, 2, 3 and 4.

FIGURE 3.1-1 ST. LUCIE 1 MIN BANT VOLUME
VS STORED BANT CONCENTRATION

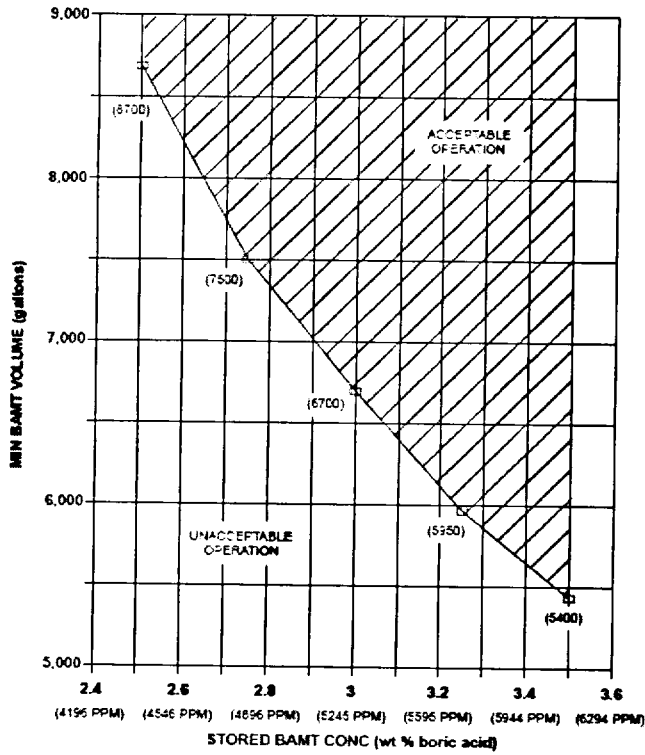

Examination Outline Cross-reference:	Level	RO	SRO
	Tier #		3
	Group #		2
	K/A #	G2.2.6	
	Importance Rating		3.3

Knowledge of the process for making changes in procedures as described in the safety analysis.

Proposed Question: SRO 97

The author of a Temporary Change (TC) to a procedure shall obtain review and signature approval from two members of the Plant Management Staff, at least ONE (1) of whom shall be:

- A. only the on-shift Shift Manager.
- B. the TC author's immediate supervisor.
- C. a SRO License holder on the affected unit.
- D. the Manager of the department responsible for the TC.

Proposed Answer: C

Explanation (Optional):

- A. Incorrect. Plausible if candidate thinks that it must be the SRO and SM.
- B. Incorrect. Plausible if candidate thinks this is required, however, the individual may not be an SRO.
- C. Correct.
- D. Incorrect. Plausible if candidate thinks this is required as they could be one of the two members, however, the individual may not be an SRO.

Technical Reference(s): ADM 11.03, Temporary Change to Procedures, Section 6.1 (Attach if not previously provided)

Proposed references to be provided to applicants during examination: _____

Learning Objective: 0702841-27 (As available)

Question Source: Bank # 1185
Modified Bank # _____ (Note changes or attach parent)
New _____

Question History: Last NRC Exam _____

Question Cognitive Level: Memory or Fundamental Knowledge . X
Comprehension or Analysis _____

10 CFR Part 55 Content: 55.41 _____
55.43 3

Comments:

REVISION NO.: 12	PROCEDURE TITLE: TEMPORARY CHANGE TO PROCEDURES	PAGE: 16 of 28
PROCEDURE NO.: ADM-11.03	ST. LUCIE PLANT	

6.1 Generating a Temporary Change (continued)**NOTE**

A Temporary Change to a procedure shall NOT be completed if the Qualified Reviewer determined that the proposed changes require the performance of a 10 CFR 50.59 Evaluation.

- 3.** The author shall verify that the 50.59 Applicability Determination is complete, and a 10 CFR 50.59 Evaluation is NOT required for the proposed changes to the procedure.
- 4.** The Author of the TC shall obtain review and signature approval from two members of the Plant Management Staff, at least one of whom holds a Senior Reactor Operator's (SRO) License on the affected unit.
- 5.** When selecting the Management Member, the Author shall:
 - A.** Select a staff member from the department responsible for the procedure or from the department affected by the TC.
 - B.** §1 Select an individual other than themselves.
- 6.** Management Member shall:
 - A.** Meet the member of Plant Management Staff requirements specified in Section 4.0, Definitions, of this procedure.
 - B.** Be an individual from the department responsible for the procedure or from the department affected by the TC.
 - C.** NOT be the individual that performed the Independent Review for the Temporary Change.
 - D.** Act as the Department Head when reviewing the change. During off normal hours this may be done per telecon.
 - E.** Verify the TC does NOT change the intent of the original procedure.
 - F.** Verify the TC is technically correct.
 - G.** Verify the TC information is added to all the affected procedure sections.
 - H.** Upon approval, sign and date Block 7 on the TC Form by clicking on the Approve button.

Examination Outline Cross-reference:	Level	RO	SRO
	Tier #		3
	Group #		3
	K/A #	G2.3.9	
	Importance Rating		3.4

Knowledge of the process for performing a containment purge.

Proposed Question: SRO 98

Unit 2 is at 100% power steady state. Containment pressure is approaching the Technical Specification limit.

Which of the following is initiated to prevent exceeding the Containment pressure Technical Specification limit?

Initiate:

- A. Containment purge using HVE-8A or HVE-8B through the Shield building ventilation filter trains.
- B. Containment mini-purge using HVE-7A or HVE-7B through the Shield building ventilation filter trains.
- C. Containment purge using HVE-8A or HVE-8B through the Continuous Containment / H2 Purge system filter trains.
- D. Containment mini-purge using HVE-7A or HVE-7B through the Continuous Containment / H2 Purge system filter trains.

Proposed Answer: D

Explanation (Optional):

- A. Incorrect. HVE-8A and HVE-8B not used for mini-purge. Plausible if candidate thinks this is an acceptable method to purge Containment.
- B. Incorrect. Shield building ventilation not used. Plausible if candidate thinks this alignment method will work to purge Containment.
- C. Incorrect. HVE-8A and HVE-8B not used for mini-purge. Plausible if candidate thinks this is an acceptable alignment to purge Containment.
- D. Correct.

Technical Reference(s): 2-NOP-25.02, Continuous Containment / Hydrogen Purge System Operation (Attach if not previously provided)

Proposed references to be provided to applicants during examination: _____

Learning Objective: 0702602-04 (As available)

Question Source: Bank # 2154
 Modified Bank # _____ (Note changes or attach parent)
 New _____

Question History: Last NRC Exam 2002

Question Cognitive Level: Memory or Fundamental Knowledge _____
 Comprehension or Analysis X

10 CFR Part 55 Content: 55.41 _____
 55.43 4, 5

Comments:

REVISION NO.: 5	PROCEDURE TITLE: CONTINUOUS CONTAINMENT/HYDROGEN PURGE SYSTEM OPERATION ST. LUCIE UNIT 2	PAGE: 3 of 12
PROCEDURE NO.: 2-NOP-25.02		
<p>1.0 PURPOSE</p> <p>1.1 This procedure provides instructions for lineup and operation of the Continuous Containment Purge System. The system can be used to maintain the Containment internal pressure within Technical Specification limitations or to reduce airborne radioactivity for containment access.</p> <p>1.2 The Hydrogen Purge section of this system is addressed in the Emergency Operating Procedures (2-EOP-99).</p>		

REVISION NO.: 5	PROCEDURE TITLE: CONTINUOUS CONTAINMENT/HYDROGEN PURGE SYSTEM OPERATION ST. LUCIE UNIT 2	PAGE: 9 of 12
PROCEDURE NO.: 2-NOP-25.02		

6.1 Containment Purge System Operation (continued)

INITIAL

NOTE

FCV-25-26 and FCV-25-36 will NOT OPEN until HVE-7A or 7B starts and a negative differential pressure exists in Containment.

7. PLACE the Control Switch for FCV-25-26, Continuous Cntmt Purge Make-up, in OPEN. _____

8. PLACE the Control Switch for FCV-25-36, Continuous Cntmt Purge Make-up, in OPEN. _____

CAUTION

§2 If a CIAS occurs, HVE-7A and HVE-7B must be shut down manually.

9. START one Continuous Containment Purge Fan:

A. HVE-7A, Continuous Cntmt/H2 Purge Fan. _____

OR

B. HVE-7B, Continuous Cntmt/H2 Purge Fan. _____

10. RECORD start time _____:_____

11. OPEN AND ADJUST FCV-25-9, Control Valve Filter Inlet, to obtain the flow rate prescribed on the Release Permit as observed on FR-25-2, Continuous Cntmt/H2 Purge Flow, or FI-25-1-1, Continuous Cntmt Purge Flow. _____

12. MARK on FR-25-2, Continuous Cntmt/H2 Purge Flow.

A. Time/Date of start of release

B. Gas Release Permit Number

Examination Outline Cross-reference:	Level	RO	SRO
	Tier #		3
	Group #		4
	K/A #	G2.4.9	
	Importance Rating		3.9

Knowledge of low power / shutdown implication in accident (e.g. LOCA or loss of RHR) mitigation strategies.

Proposed Question: SRO 99

Unit 1 Unit Supervisor has taken the turnover during a refueling outage with the following conditions:

- Mode 3 performing a controlled cooldown.
- RCS Tave: 450°F.
- Steam Generator pressure: 413 psia.
- RCS pressure: 1280 psia.

Fifteen minutes after the turnover the following condition exist:

- RCS pressure and level are falling.
- RCS temperature is stable.
- Steam Generator pressure is stable.

What procedure and mitigation strategy should be implemented?

- ONP-01.01, Plant Condition 1 - SG Heat Removal LTOP not in effect.
Attempt to isolate the affected SG.
Maintain RCS subcooling 20-200°F.
- ONP-01.02, Plant Condition 2 - SG Heat Removal LTOP in effect.
Manually actuate MSIS and SIAS.
Stabilize RCS temperature and pressure.
- EOP-03, Loss of Coolant Accident.
Manually actuate SIAS.
Maintain RCS subcooling 20-200°F.
- EOP-15, Functional Recovery.
Emergency borate and attempt to isolate the affected SG.
Stabilize RCS temperature and pressure.

Proposed Answer: **A**

Explanation (Optional):

- A. Correct.
- B. Incorrect. Conditions not met for LTOP. Plausible if candidate misdiagnoses the event and thinks that ESFAS actuations are required.
- C. Incorrect. In this condition SIAS is blocked, therefore, EOPs don't apply. Plausible if candidate recognizes LOCA but don't realize SIAS is blocked.
- D. Incorrect. In this condition SIAS is blocked, therefore, EOPs don't apply. Plausible if candidate thinks multiple conditions exist to enter the FR.

Technical Reference(s): 1-GOP-305, Reactor Plant (Attach if not previously provided)
Cooldown - Hot Standby to Cold
Shutdown

Proposed references to be provided to applicants during examination: _____

Learning Objective: _____ (As available)

Question Source: Bank # 1864
 Modified Bank # _____ (Note changes or attach parent)
 New _____

Question History: Last NRC Exam _____

Question Cognitive Level: Memory or Fundamental Knowledge _____
 Comprehension or Analysis X

10 CFR Part 55 Content: 55.41 10
 55.43 _____

Comments:

Examination Outline Cross-reference:	Level	RO	SRO
	Tier #	_____	<u>3</u>
	Group #	_____	<u>4</u>
	K/A #	G2.4.44	_____
	Importance Rating	_____	<u>4</u>

Knowledge of emergency plan protective action recommendations.

Proposed Question: SRO 100

A General Emergency has been declared. The minimum PARs for a General Emergency have been given to the State. Wind direction is 281°.

An offsite dose calculation has now been manually performed and the data is as follows: (values are in mRem).

	1 mile	2 miles	5 miles
Whole body (TEDE)	3411	1218	341
Thyroid (CDE)	9628	3398	962

The release duration is expected to be greater than 2 hours.

Select the PARs to be reported to the State on the next message.

0-2 Miles / 2-5 Miles / 5-10 Miles

(EPIP-08, Attachment 2, Determination of Protective Action Recommendations is provided.)

- A. 0-2 miles: Evacuate (ALL)
2-5 miles: Shelter (DEF) + Shelter all remaining sectors
5-10 miles: Evacuate (DEF) + Shelter all remaining sectors
- B. 0-2 miles: Evacuate (ALL)
2-5 miles; Evacuate (DEF) + Shelter all remaining sectors
5-10 miles: NO actions
- C. 0-2 miles: Evacuate (ALL)
2-5 miles: Evacuate (DEFG) + Shelter all remaining sectors
5-10 miles: NO actions
- D. 0-2 miles: Evacuate (ALL)
2-5 miles: Evacuate (DEFG) + Shelter all remaining sectors
5-10 miles: Shelter (DEFG)

Proposed Answer: C

Explanation (Optional):

- A. Incorrect. Partially correct. Plausible if candidate thinks overlapping sectors need not be evacuated.
- B. Incorrect. Partially correct. Plausible if candidate thinks overlapping sectors need not be evacuated.
- C. Correct.
- D. Incorrect. Partially correct. Plausible if candidate misreads flowchart and thinks sectors at 5-10 miles require shelter.

Technical Reference(s): EPIP-08, Offsite Notifications and PARs (Attach if not previously provided)

Proposed references to be provided to applicants during examination: EPIP-08, Attachment 2

Learning Objective: 0902701-07 (As available)

Question Source: Bank # 2653
 Modified Bank # _____ (Note changes or attach parent)
 New _____

Question History: Last NRC Exam _____

Question Cognitive Level: Memory or Fundamental Knowledge _____
 Comprehension or Analysis X

10 CFR Part 55 Content: 55.41 _____
 55.43 5

Comments:

REVISION NO.: 10	PROCEDURE TITLE: OFF-SITE NOTIFICATIONS AND PROTECTIVE ACTION RECOMMENDATIONS ST. LUCIE PLANT	PAGE: 37 of 46
PROCEDURE NO.: EPIP-08		

ATTACHMENT 2
DETERMINATION OF PROTECTIVE ACTION RECOMMENDATIONS (PARs)
(Page 1 of 6)

NOTE

- Initial notification from the Control Room may utilize PARs based on plant conditions.
- Once dose assessment begins, PARs should be made utilizing **all** available data including off-site dose projections, plant conditions and field monitoring data.
- **Both plant conditions and off-site doses shall be considered for PARs.**
- **The most conservative recommendations should be made.**
- If it is anticipated that a threshold for a PAR will be exceeded, it is **neither necessary nor desirable to wait until the threshold is exceeded to make that PAR.**
- ¶12 Conditions (plant information, dose projections and field monitoring results) are to be continually assessed and PARs expanded, **as necessary, to ensure that adequate (most conservative) PARs are issued.**
- ¶12 Previously issued PARs, unless found to be less conservative, are to remain in effect until the threat is fully under control and the event is being de-escalated.
- ¶12 Only State and County officials can implement, change and/or terminate protective actions.

1. PAR Flowchart

A. Instructions for PARs Based on Plant Conditions

- 1. Begin in the upper left hand corner of the chart by answering the General Emergency (GE) question.**
- 2. Correctly answer the questions until you reach one of the boxes that provides PAR information based on plant conditions.**
- 3. If there is no release, Then go to the PAR Worksheet and fill-in the PARs based on plant conditions. The sectors affected can be determined by referring to number 8, Weather Data, in Attachment 1A, Directions for Completing the Florida Nuclear Plant Emergency Notification Form.**
- 4. If a release is involved, Then go to Section B, Instructions for PARs Based on Off-site Dose, below.**

REVISION NO.: 10	PROCEDURE TITLE: OFF-SITE NOTIFICATIONS AND PROTECTIVE ACTION RECOMMENDATIONS ST. LUCIE PLANT	PAGE: 38 of 46
PROCEDURE NO.: EPIP-08		

ATTACHMENT 2
DETERMINATION OF PROTECTIVE ACTION RECOMMENDATIONS (PARs)
(Page 2 of 6)

1. (continued)

NOTE

- If the Class A Model printout, State Notification Form Summary Sheet is available, it should be used to compare dose-based PARs against PARs based on plant conditions.
- Calculated off-site doses should be compared to field monitoring data when determining PARs.

B. Instructions for PARs Based on Off-site Dose

- 1.** PARs are based on the Total Effective Dose Equivalent (TEDE or total dose) and / or the Committed Dose Equivalent (CDE, thyroid dose). **Do NOT use dose rate values.**
- 2.** If performing dose calculations using the Class A Model, Then in Forecast Mode, print the State Notification Form Summary for computer generated PARs.
 - a.** Go to Section C, Instructions for the PAR Worksheet, below.
- 3.** If dose calculations were performed manually using EPIP-09, Off-site Dose Calculations, Then calculate TEDE and CDE in accordance with the procedure.
 - a.** Compare the TEDE dose at 1 mile with the values on the Flowchart. Enter the chart at the appropriate dose level by determining if the dose is between 500 and 999 mrem or between 1000 and 4999 mrem or 5000 mrem or greater.
 - b.** From the selected dose level, move to the right on the chart to the first column, 0-2 miles. The PAR provided corresponds to the calculated TEDE at 1 mile.
 - c.** Enter the PAR in the 0-2 miles block on the TEDE DOSE table below the PAR Flowchart. The sectors affected can be determined by referring to number 8, Weather Data, in Attachment 1A, Directions for Completing the Florida Nuclear Plant Emergency Notification Form.
 - d.** Continue to determine the corresponding PAR at 2-5 miles using the calculated 2 mile TEDE, at 5-10 miles using the calculated 5 mile TEDE and the 10 miles plus (To Be Determined (TBD) distance) using the calculated 10 mile TEDE, as necessary.
 - e.** Enter the PAR information in the appropriate blocks of the TEDE DOSE table.

REVISION NO.: 10	PROCEDURE TITLE: OFF-SITE NOTIFICATIONS AND PROTECTIVE ACTION RECOMMENDATIONS ST. LUCIE PLANT	PAGE: 39 of 46
PROCEDURE NO.: EPIP-08		

ATTACHMENT 2
DETERMINATION OF PROTECTIVE ACTION RECOMMENDATIONS (PARs)
(Page 3 of 6)

- 1. B. 3. (continued)**
 - f.** Follow the same methodology for determining the PARs corresponding to the calculated CDE values beginning with the calculated value at 1 mile.
 - g.** Enter each of the determined PARs in the CDE (Thyroid) DOSE table below the PAR Flowchart.
 - h.** Go to Section C, Instructions for the PAR Worksheet, below.
- C. Instructions for the PAR Worksheet**
 - 1.** Fill-in the time / date and emergency class.
 - 2.** In Part A, determine the most conservative PARs by comparing the PARs based on plant conditions against those based on off-site dose. It is important to compare PARs at each distance (0-2, 2-5, 5-10) because the basis of the most conservative PAR could be different at different distances.
 - 3.** Enter the most conservative PARs into the table in Part B, Protective Actions Recommended by FPL. Use the word(s) NONE, ALL, ALL REMAINING or list the individual affected sectors by letter.
 - 4.** Obtain review and approval.
 - 5.** Transfer the approved PARs to the Florida Nuclear Plant Emergency Notification Form.

REVISION NO.: 10	PROCEDURE TITLE: OFF-SITE NOTIFICATIONS AND PROTECTIVE ACTION RECOMMENDATIONS ST. LUCIE PLANT	PAGE: 40 of 46
PROCEDURE NO.: EPIP-08		

ATTACHMENT 2
DETERMINATION OF PROTECTIVE ACTION RECOMMENDATIONS (PARs)
(Page 4 of 6)

PARs Based on Plant Conditions

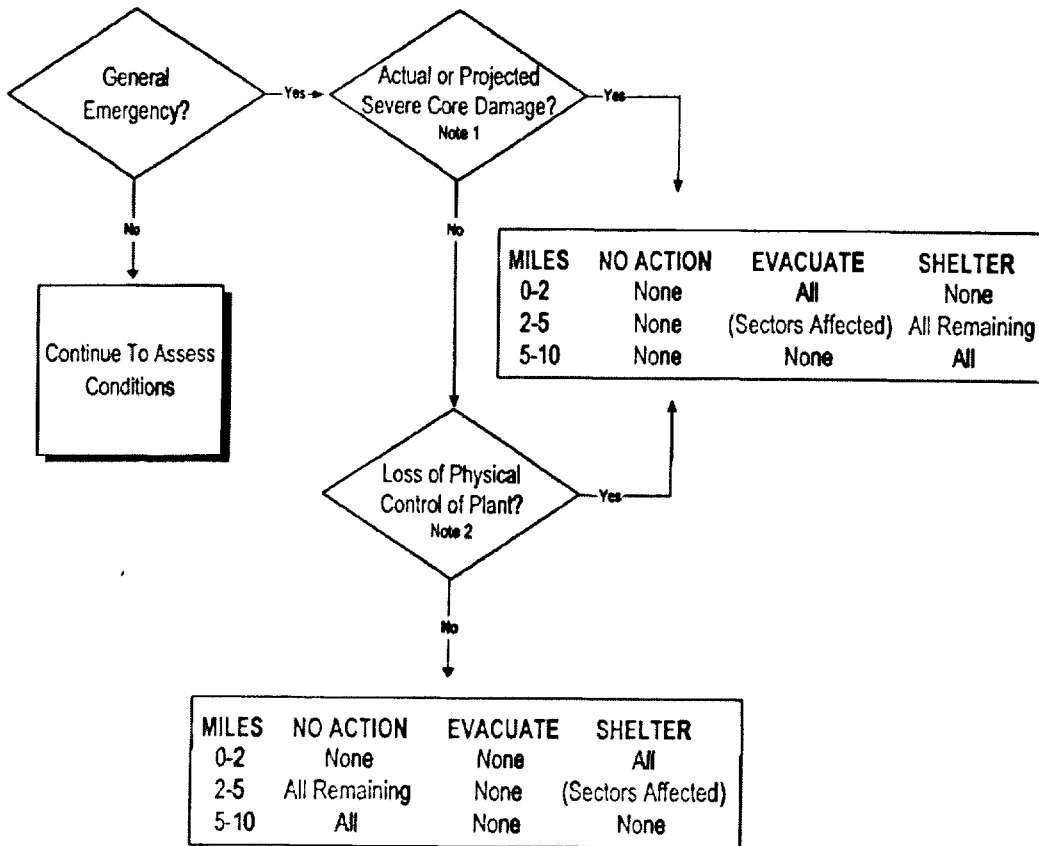

(D/PS/EPLAN/RS 14-000)

Notes

1. Severe core damage is indicated by:

- Loss of critical functions required for core protection (e.g., loss of injection with LOCA) OR
- High core temperatures (valid CET greater than 700° F) OR
- CHRHM reading greater than 4.2 E4 R/hr.

2. Loss of physical control of Control Room or vital reactor operating areas to intruders.

REVISION NO.: 10	PROCEDURE TITLE: OFF-SITE NOTIFICATIONS AND PROTECTIVE ACTION RECOMMENDATIONS ST. LUCIE PLANT	PAGE: 41 of 46
PROCEDURE NO.: EPIP-08		

**ATTACHMENT 2
DETERMINATION OF PROTECTIVE ACTION RECOMMENDATIONS (PARs)
(Page 5 of 6)**

PARs Based on Manual Dose Calculation

Release Duration Less Than 2 Hours (Puff Release)

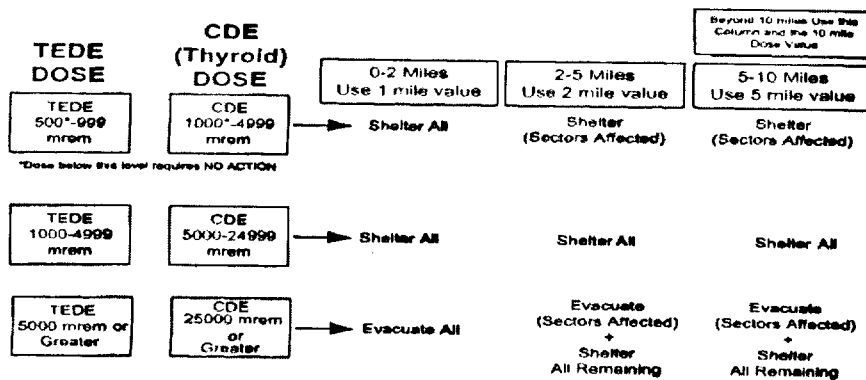

Release Duration Greater Than or Equal to 2 Hours

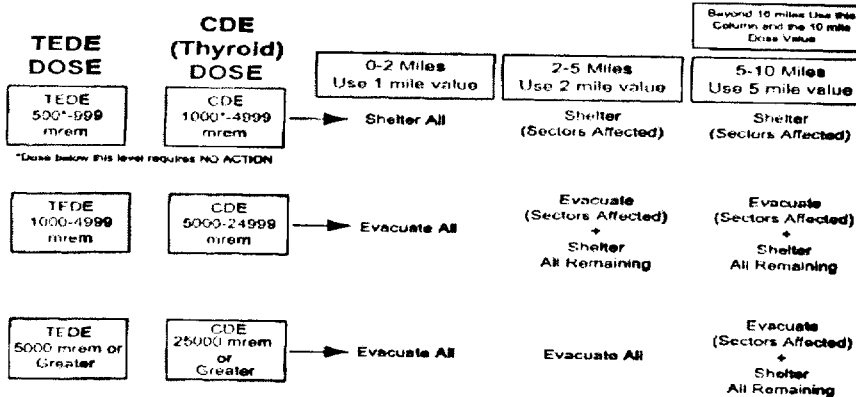

(DFSEPLAN-FS 10-R30)

REVISION NO.: 10	PROCEDURE TITLE: OFF-SITE NOTIFICATIONS AND PROTECTIVE ACTION RECOMMENDATIONS ST. LUCIE PLANT	PAGE: 42 of 46
PROCEDURE NO.: EPIP-08		

**ATTACHMENT 2
DETERMINATION OF PROTECTIVE ACTION RECOMMENDATIONS (PARs)
(Page 6 of 6)**

Time / Date _____ Emergency Class: SAE GE

A. PAR Comparison

After comparing the possible recommendations from the PARs flowchart, the most conservative PARs are based on: (check one)

PLANT CONDITIONS OFF-SITE DOSE

B. Protective Actions Recommended by FPL:

Use the following terms in this table: **NONE, ALL, ALL REMAINING** Or fill in the letters of the sectors affected.

	NO ACTION SECTORS	EVACUATE SECTORS	SHELTER SECTORS
0-2 miles			
2-5 miles			
5-10 miles			
10-TBD miles*			

*If necessary, add to State Notification Form.

Control Room

Signature _____
Emergency Coordinator

Technical Support Center

Signature _____ TSC EC Assistant / Logkeeper
Signature _____ TSC HP Supervisor or TSC Chemistry Supervisor

Emergency Operations Facility

Signature _____ EOF RM OPS Advisor / Logkeeper
Signature _____ EOF HP Manager

END OF ATTACHMENT 2

DRAFT

Q#	1. LOK (F/H)	2. LOD (1-5)	3. Psychometric Flaws				4. Job Content Flaws			5. Other		6. U/E/S	7. Explanation	
			Stem Focus	Cues	T/F	Cred. Dist.	Partial	Job-Link	Minuta	#/units	Back-ward			O=K/A Only

Instructions

[Refer to Section D of ES-401 and Appendix B for additional information regarding each of the following concepts.]

1. Enter the level of knowledge (LOK) of each question as either (F)undamental or (H)igher cognitive level.
2. Enter the level of difficulty (LOD) of each question using a 1 – 5 (easy – difficult) rating scale (questions in the 2 – 4 range are acceptable).
3. Check the appropriate box if a psychometric flaw is identified:
 - The stem lacks sufficient focus to elicit the correct answer (e.g., unclear intent, more information is needed, or too much needless information).
 - The stem or distractors contain cues (i.e., clues, specific determiners, phrasing, length, etc).
 - The answer choices are a collection of unrelated true/false statements.
 - The distractors are not credible: single implausible distractors should be repaired, more than one is unacceptable.
 - One or more distractors is (are) partially correct (e.g., if the applicant can make unstated assumptions that are not contradicted by stem).
4. Check the appropriate box if a job content error is identified:
 - The question is not linked to the job requirements (i.e., the question has a valid K/A but, as written, is not operational in content).
 - The question requires the recall of knowledge that is too specific for the closed reference test mode (i.e., it is not required to be known from memory).
 - The question contains data with an unrealistic level of accuracy or inconsistent units (e.g., panel meter in percent with question in gallons).
 - The question requires reverse logic or application compared to the job requirements.
5. Check questions that are sampled for conformance with the approved K/A and those that are designated SRO-only (K/A and license level mismatches are unacceptable).
6. Based on the reviewer's judgment, is the question as written (U)nsatisfactory (requiring repair or replacement), in need of (E)ditorial enhancement, or (S)atisfactory?
7. At a minimum, explain any "U" ratings (e.g., how the Appendix B psychometric attributes are not being met).

SRO Questions

Q#	H	2	X									U		
76	H	2	X									U		

015AA2.10 Question appears to match K/A. NRC randomly selected AA2.01 or AA2.08. Distractor D is not plausible the applicant is an SRO and is the Unit Supervisor. Question would be better if the time of 10 minutes were used in the distractors. Licensee selected AA2.10 on their own (This happened to be a **BANK** question Instructed Licensee to use AA2.01 or AA2.08 as originally selected.

Q#	1. LOK (F/H)	2. LOD (1-5)	3. Psychometric Flaws					4. Job Content Flaws			5. Other		6. U/E/S	7. Explanation	
			Stem Focus	Cues	T/F	Cred. Dist.	Partial	Job-Link	Minutia	# units	Back-ward	Q=K/A			SRO Only
77	H	2	X											U	022AG2.2.22 Question appears to meet K/A. LCO 3.0.3 is the same no matter what the cause. So how can one be more limiting than the other. Stem needs to be written to ask which one of the following describes which technical specification is applicable or something similar to that. This was a K/A that was swapped from the RO sample plan to the SRO sample plan and the Licensee has been instructed to swap it back to the original sample plans. (NEW)
78	H	2												U	040AG2.4.6 Question does not meet K/A, and is not SRO only. This is procedure entry conditions and is not SRO only knowledge. K/A also asks for mitigation strategies and again this is only procedure entry conditions. Need to write question to meet K/A.. (BANK)
79	H	2												U	057AG2.1.33 Question meets K/A. Not modified, if the applicant knows the answer from the bank question, he can still answer this question because the original answer is still present and the action doesn't even need to be looked at. So the question really does not match the K/A at this point. (BANK)
80															Licensee pick a different K/A without NRC permission. The NRC will randomly select another KA. <u>062G2.4.45</u> selected.
81	H	1												U	065AG2.4.4 Question appears to match K/A. Actions are not required to be known to answer this question, knowing the result of a loss of air on charging and ledown is all that is required. Question needs more work. (BANK)

Q#	1. LOK (F/H)	2. LOD (1-5)	3. Psychometric Flaws					4. Job Content Flaws			5. Other		6. U/E/S	7. Explanation	
			Stem Focus	Cues	T/F	Cred. Dist.	Partial	Job-Link	Minutia	#/units	Back-ward	Q=K/A			SRO Only
82	H	2										X	X	U	003AG2.4.49 Question does not really meet the K/A, but is a good attempt. Not SRO only. Distractors do not appear to be credible. Correct answer has Local Linear heat rate, but T/S does not. D could also be correct. Replace or repair question. (BANK)
83	H	2										X		U	005AG2.4.50 Question does not really meet K/A. What system alarm setpoints are verified, and what actions in the alarm response procedure are in the question? (BANK)
84															Licensee changed K/A without NRC permission. NRC randomly selected 032AA2.01 or 2.08. Licensee to write another question on correct K/A
85	H	2												E	060AA2.03 Question appears to match K/A. Distractor A does not appear to be credible (all pressures would have to go up to this to happen) to stop the release the only valve that needs to be closed is V6565, and this is in every answer. Need to explain flowpath, I can not see with the drawings provided.
86															063A2.01 this question was originally on the RO exam and the licensee swapped it to the SRO exam, without NRC permission. Question (K/A) needs to be swapped back as it was originally.
87	H	2												E	062A2.05 Question appears to match K/A. Not sure if all the distractors are credible. Need to discuss. Again if an applicant remembered the bank question correctly he would not have to know what procedure to use. (MODIFIED) Question is not actually modified.

Q#	1. LOK (F/H)	2. LOD (1-5)	3. Psychometric Flaws					4. Job Content Flaws				5. Other		6. U/E/S	7. Explanation		
			Stem Focus	Cues	T/F	Cred. Dist.	Partial	Job-Link	Minutia	#/units	Back-ward	Q=K/A	SRO Only				
88	H	2											X			U	006A2.02 Question is close to K/A, however the actual flow path is still intact. A leak flow should be used (200 gpm) or similar instead of stating that a SBLOCA exists this will allow some of the other distractors to be more plausible. Question still needs work. (BANK)
89	H	2														U	103G2.1.12 Question appears to match K/A. With the conditions of the inner door given why would anyone select B or D. These do not appear credible. (BANK)
90	H	2														S	064G2.1.32 Question appears to match K/A. Very simple but appears to be sat. (NEW)
91	H	2							X	X						U	029A2.04 Question appears to match K/A. Distractor B is not credible. All of the responses contain actions, so why does the stem contain if any? Distractor D could also be correct. What procedure directs chemistry to sample? What procedure directs securing the purge. Why is the X15 alarm in the question? Question needs to be swapped back to the RO Exam. (NEW)
92	H	2											X			U	075A2.02 Question matches part of the K/A. This is really a combination of system knowledge. 1 how does CW flow through the condenser, and two what is the trip setpoint. The Question should have something in it about the use of procedures. LAW ONOP-... What actions should be taken. (BANK)
93	H	2												X		U	041G2.1.33 Question Matches K/A Not SRO only, an RO would also know is he exceeded the cooldown rate limit. For an SRO what actions need to be taken LAW T/S. (NEW)
94	F	2											X			U	G2.1.10 Question does not really meet the K/A. (Facility License not individual). Distractor C is also correct. (BANK)

Q#	1. LOK (F/H)	2. LOD (1-5)	3. Psychometric Flaws					4. Job Content Flaws			5. Other		6. U/E/S	7. Explanation	
			Stem Focus	Cues	T/F	Cred. Dist.	Partial	Job-Link	Minutia	#/units	Back-ward	Q=K/A			SRO Only
95	F	1										X	X	U	G2.1.11 Does not meet the K/A, and is not SRO only. The K/A asks for Knowledge of less than 1 hor action statements for systems, however this question asks which systems has a 1 hour T/S. It does not test the knowledge of the actions (what is to be done) Can be fixed. Used on 2002 NRC retake Exam. Level of difficulty is a 1 for an SRO. (BANK) This K/A was swapped from the RO exam and needs to be swapped back to the RO exam.
96	H	2										X		U	G2.2.24 This K/A was swapped from the RO exam to the SRO exam and will be swapped back. Question does not really meet the K/A. This maintenance has no effect on operation. It should have been asked: Maintenance is required to be performed on can this Maintenance be performed? Or something similar. (BANK)
97	F	1	X											U	G2.2.6 Question appears to match K/A. Teaching in stem. Question should read Who can approve a temporary change IAW... Look at ADM-11.03 section 6.1. As written does not have much discriminatory value. (BANK)
98	F	2										X	X	U	G2.3.9 Question does not meet K/A. Not SRO ONLY This question asks what needs to be performed to prevent exceeding T/S. It does not ask anything about the process, or what is involved in performing the purge. (BANK 2002 NRC Exam)
99	H	2	X											U	G2.4.9 This K/A was swapped from the RO exam to the SRO exam and will be swapped back. How can A be the correct answer with S/G pressure stable? The answer states to isolate effected generator but both S/G pressures are stable. Does not make sense. (BANK)
100	H	2												E	G2.4.44 Question matches K/A. This is more in line with an Administrative JPM. There is not map to verify the zones.