

MALLINCKRODT
NUCLEAR
CORPORATION

70-36
File 9.

AIR MAIL

SAINT LOUIS 7, MISSOURI • U.S.A. • CENTRAL 1-8980
PLANT
HEMATITE, MISSOURI

March 3, 1960

Mr. J. C. Delaney
Licensing Branch
Division of Licensing & Regulation
U. S. Atomic Energy Commission
Washington 25, D. C.

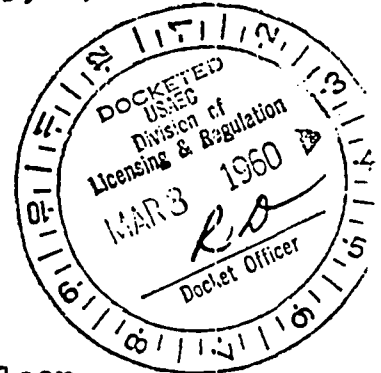

SUBJECT: Extension of Special Nuclear
Materials License No. 33 to
Include 55-gallon "Shorty"
5-Gallon Pail Shipping Container

Dear Mr. Delaney:

Please reconsider our request for a license for the subject shipping container disregarding previous correspondence on this subject.

We plan to use this container for mass controlled shipments of uranium compounds having a U-235 enrichment up to 10%. A maximum single layer shipment of 24 drums would be made by air, LTL, LCL, or railway express.

The container is shown on the enclosed Mallinckrodt drawing numbered 3369-3 and 3369-2. The uranium compound is packaged in the inner 5-gallon type 37A pail. This pail is centered inside a standard 55-gallon "shorty" drum by means of angle iron stools as shown on the drawings. A steel hoop or skirt has been added to the 55-gallon drum increasing its diameter to 27 inches. The lid of each drum is gasketed to prevent water inleakage and has a clamping ring holding the lid firmly in place. In addition, the words "Do Not Stack" will be stenciled on the outside of the 55-gallon drum and a pyramid frame has been added to the drum lid as shown on the enclosed sketch titled "55 Gallon Drum Lid Addition".

To be filed in Reports File.

The inter-action solid angle calculations are based on a full 5-gallon pail. The inner dimensions of this pail are 11-1/4 inches inside diameter by 12-1/2 inches high.

*By this opp.
sent by airmail
3-11-60*

9-13

Mr. J. C. Delaney
March 3, 1960
Page Two--

The method of calculation follows page 21 of K-1309, "General Application of a Theory of Neutron Interaction" dated 11/15/56. A single layer hexagonal array of 24 drums is shown on the attached sketch titled "55-Gallon Shorty 5-Gallon Pail Maximum Shipment". The total fractional solid angle subtended by the most central drum in a 24 drum shipment is 0.17. With a "twin" shipment, in an adjacent vehicle, the total fractional solid angle subtended by the most central drum is 0.207 which is high since no allowance for normal spacing between a truck or car was included. A K factor of .65 is applicable for mass controlled shipments (Section 3.3, paragraph 2a, page 22, TID-7019) and, therefore, a maximum fractional solid angle of .20 is permitted (Appendix 5, page 75, TID-7019). An example of the solid angle calculation follows:

$$\bar{\Omega} = \text{Average fractional solid angle}$$

$$\sigma = \frac{\text{Edge to edge separation}}{\text{diameter}}$$

$$\lambda = \frac{\text{Height}}{\text{Diameter}}$$

For the first neighbor:

$$\sigma = 1.4$$

$$\lambda = 1.11 - \text{This is constant for all neighbors}$$

$$\bar{\Omega} = .021 - \text{From Figure 2, page 21, K-1309}$$

The maximum inside width of a box car is 9'-2"; the maximum inside width of a truck is 7'-8". Therefore, the array shown on the enclosed sketch is the most compact single layer array that can exist on a car or truck.

The quantity of material shipped in each container will be a limited safe mass as listed in Table II, page 13 of TID-7019, "Guide to Shipment of U-235 Enriched Uranium Materials". For enrichments up to and including 5%, the material will be packaged in the 5-gallon pail. For U-235 enrichments from 5% to 10%, the material will be packaged in a polyethylene bottle or metal can having a volume more equal to the material volume. This bottle or can would then be packed in the 5-gallon pail with vermiculite. In this case there will be additional safety since the solid angle has been calculated on the basis of a full 5-gallon pail.

Mr. J. C. Delaney
March 3, 1960
Page Three--

In the case of material having an enrichment of 5%, the material will probably occupy less than half the volume of the 5-gallon pail. Protection against exceeding a limited safe batch is afforded by the last step of our production. This is a blending operation which is used to obtain product uniformity. Normally a limited safe mass is used as a production batch. Ten such batches are blended together to make a lot. The blending procedure consists of distributing each batch equally between ten drums. Only one batch is sub-divided at a time. The net weight of material before blending is compared to the net weight of material after blending to make sure all the material is accounted for. In addition, the net weight of material in each drum of the blended lot is compared to the net weight of all other drums in the lot. This serves to expose any drums having more than the specified quantity, in which case the excess amount is removed and placed in a light drum.

It should be noted that the possibility of exceeding the limited safe mass in any drum by more than 20% is very small. The operation is performed by hand using a scoop which holds only a few pounds. Since the material from one drum is divided between ten drums, the operator would have to consistently place extra material in the same drum throughout the entire blending operation.

To supplement the above safety considerations, we will also obtain certification from the carrier that he will not place our shipment on the same vehicle with another nuclear shipment and also that he will not store our shipment alongside another nuclear shipment at points of transfer enroute.

Please let us know if you require additional information in order to issue the requested license.

Respectfully yours,

MALLINCKRODT NUCLEAR CORPORATION



L. J. Swallow
Hematite Plant

LJS/jrt

cc: AEC (3)

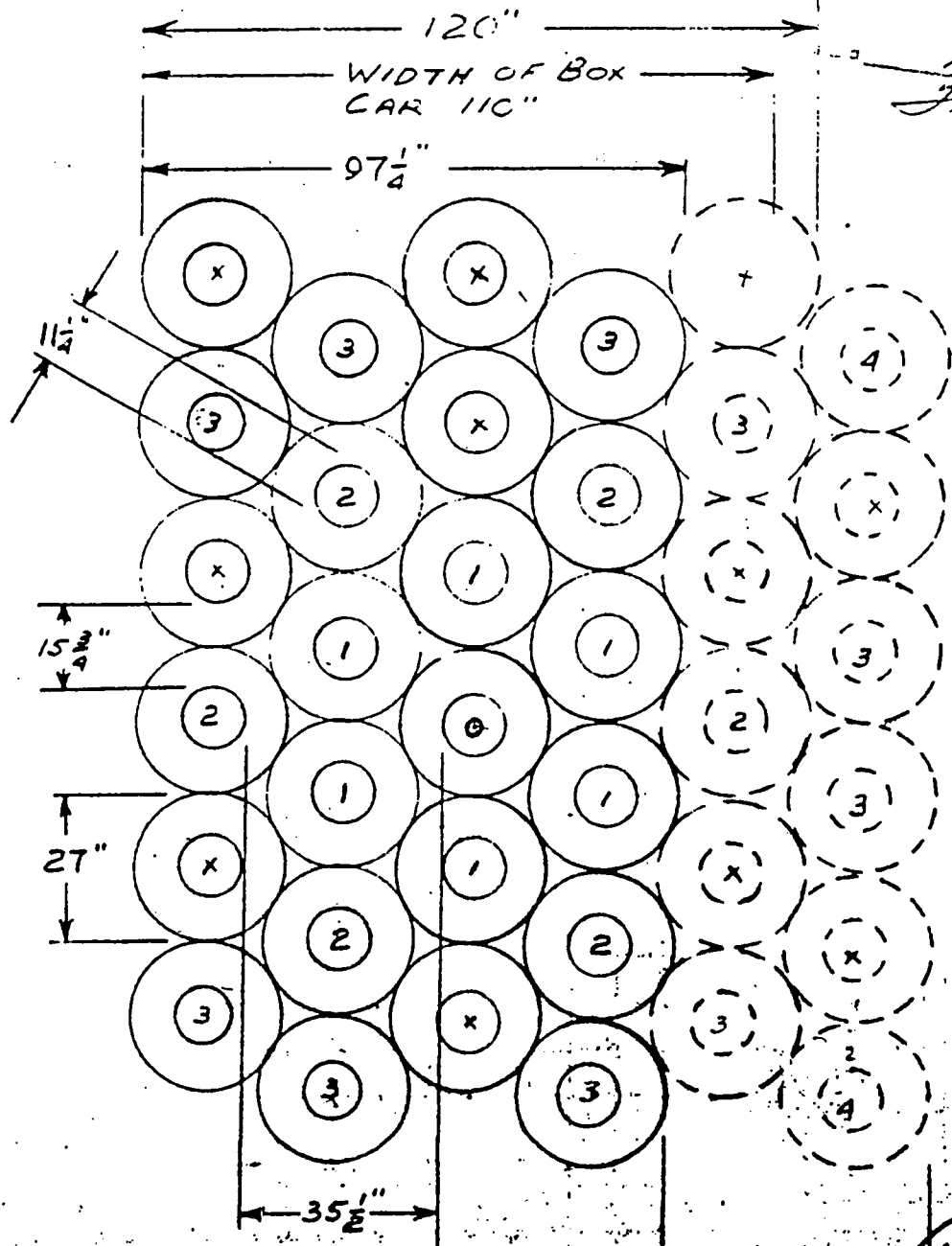

70-56
 File *cy*

- 0 CENTRAL CONTAINER
- 1 1ST NEIGHBOR
- 2 2ND NEIGHBOR
- 3 3RD NEIGHBOR
- 4 4TH NEIGHBOR
- X NOT SEEN BY O.

← HALF OF TWIN.

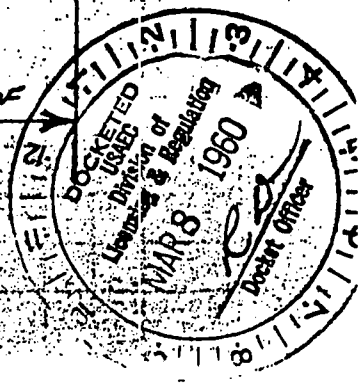

55 GALLON SHORTY - 5 GALLON PAIL
 MAXIMUM SHIPMENT

55 GAL. DRUM LID

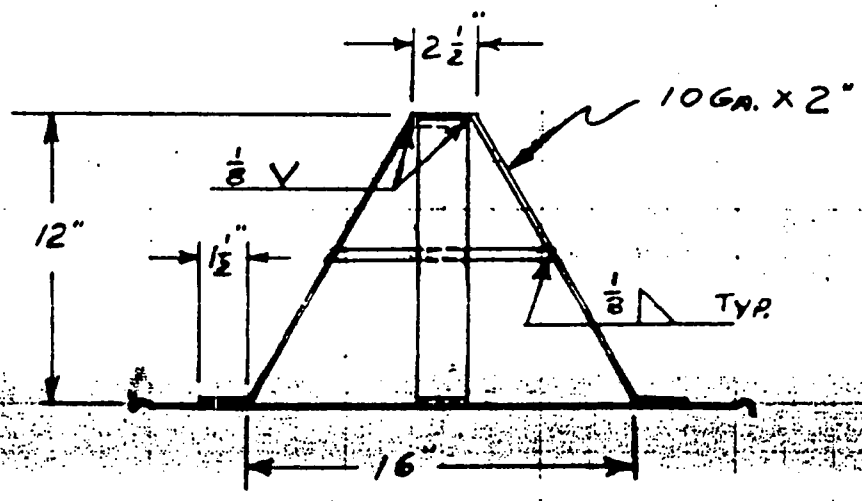
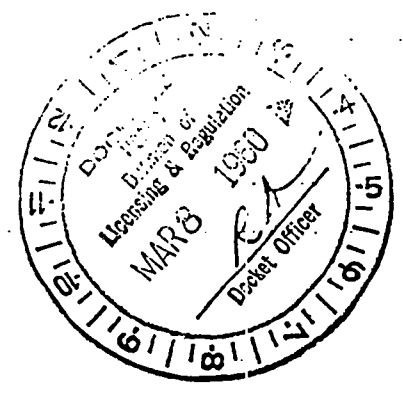
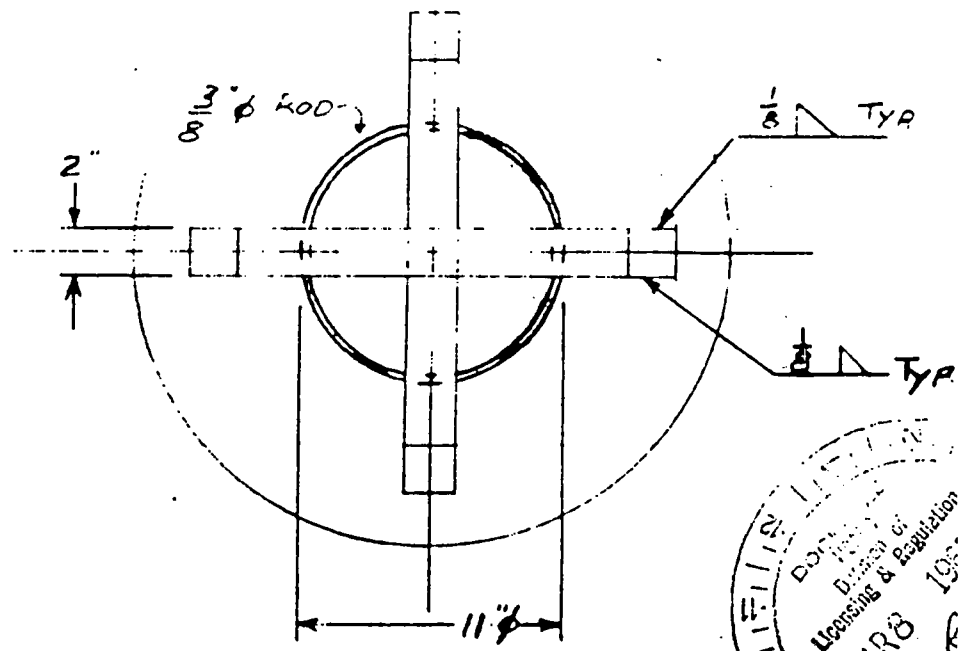

55 GALLON DRUM LID ADAPTER