

TENNESSEE VALLEY AUTHORITY
River System Operations & Environment
River Operations

Hydrothermal Modeling of Browns Ferry Nuclear Plant With Units 1, 2, and 3 at Extended Power Uprate

WR2005-1-67-135

Prepared by
Paul N. Hopping
and
Walter L. Harper

Knoxville, Tennessee

February 2005



EXECUTIVE SUMMARY

The Tennessee Valley Authority currently is in the process of restoring the third and last unit to service at the Browns Ferry Nuclear Plant (BFN). In addition, the maximum power of all three units is being increased to 120 percent of their original design level. In light of these changes, the purpose of this study is to evaluate the impacts of the additional waste heat on the operation of the plant. This is needed to help TVA make optimal decisions regarding upgrades to the cooling system, particularly the cooling towers. The impacts of the waste heat will emerge as energy losses in unit derates and cooling tower operation, which are needed to protect the water temperature limit in the receiving stream, specified in the National Pollutant Discharge Elimination System (NPDES) permit for the plant. Of particular importance is the magnitude of unit derates, which directly influence the potential need to upgrade the cooling tower system.

The evaluation of the waste heat was conducted using a computer model that simulates the operation of BFN and estimates the hydrothermal behavior of the plant condenser cooling water system and the receiving stream. A detailed description of the model formulation, data, assumptions, and simulation results are provided herein. An independent review of the study found the modeling approach to be appropriate, adequate, and properly implemented to satisfy the purpose of the study. The review also found the major processes and factors included in the model to be valid and the results to be practical and reasonable.

Inherent uncertainties in the model formulation, data, and assumptions dictate the need to express results in terms of ranges of energy loss. This was accomplished by sensitivity evaluations involving variations in a number of model parameters. The key results for unit derates are as follows for three units operating at 120 percent extended power uprate (EPU):

Current cooling tower configuration (four original 16-cell towers and one newer 16-cell tower)

- On the average, significant unit derates are likely to occur about once every 1 to 4 years.
- Individual derate events could include the shutdown of all three units.
- In extreme years, the annual derate energy loss is expected to fall between about 320,000 MWh and 530,000 MWh.
- The average derate energy loss is expected to fall between about 30,000 MWh and 110,000 MWh per year.

Cooling tower configuration identified as the TVA preferred alternative in the 2002 Final Supplemental Environmental Impact Statement for BFN operating license renewal (four original 16-cell towers, one newer 16-cell tower, and one new 20-cell tower)

- On the average, significant unit derates are likely to occur about once every 3 to 5 years.
- Individual derate events could include the shutdown of all three units.
- In extreme years, the annual derate energy loss is expected to fall between about 191,000 MWh and 375,000 MWh.
- The average derate energy loss is expected to fall between about 15,000 MWh and 40,000 MWh per year.

Results for other cooling tower scenarios are provided in this report. None of the cooling tower scenarios considered herein completely eliminated the potential occurrence of unit derates. In part, this is because the simulations included the warmest year in the period of available record, 1993. Since there are no acceptable methods to reliably forecast years of extreme summertime meteorology, the potential impact of a year such as 1993 cannot, at this time, be dismissed in model results.

Almost all the energy losses reported herein are associated with the NPDES limit for the 24-hour running average downstream temperature, 90°F. The limit for the 24-hour running average instream temperature rise is 10°F. Even though the model results predict no problems with the temperature rise, historical observations have recorded temperature rise events in excess 8°F. Since the hydrothermal model was calibrated primarily for summer conditions, and due to uncertainties associated with the behavior of the plant waste heat in low river flows, the potential for events threatening the limit for instream temperature rise is yet considered significant.

Results of the hydrothermal model suggest that it may be possible to reduce derate energy losses by “early” operation of the cooling towers. However, for NPDES temperature limits based on a 24-hour average, this is true only if the unit derate occurs within 24 hours of startup of the cooling towers. In general, it is best to have cooling towers in service well before 24 hours of a potential derate, to ensure that cooling tower equipment is working at peak efficiency, and to ensure that the downstream temperature is as cool as possible when entering the 24-hour window before a potential unit derate.

Comments in the independent review and observations in the sensitivity evaluations indicate that the greatest sources of uncertainty in the hydrothermal model are likely related to the complex, three-dimensional behavior of the river upstream and in the immediate vicinity of BFN. Algorithms incorporating a mixture of advanced three-dimensional numerical modeling and statistical techniques could potentially reduce this uncertainty. TVA currently is investigating some of these algorithms. Flow algorithms different from that currently used by TVA also are readily available and could perhaps improve predictions for reverse river flow events at BFN.

From the standpoint of the plant, significant sources of modeling uncertainty are found in the cooling tower performance (e.g., capability) and plant water routing during helper-mode operation (i.e., sluicing part of the plant discharge directly to the diffusers). To reduce these uncertainties, the plant should consider simple measurements of water level, flow, and temperature at key locations in the cooling system during helper-mode operation.

TABLE OF CONTENTS

EXECUTIVE SUMMARY	i
TABLE OF CONTENTS.....	iv
LIST OF FIGURES	v
LIST OF TABLES.....	vi
INTRODUCTION	1
BACKGROUND	2
Basic Site Conditions.....	2
Condenser Cooling Water System.....	4
NPDES Water Temperature Limits	11
METHODOLOGY	14
Model Overview	14
Simulation Period.....	15
Meteorology	16
Upstream River Temperature.....	18
Upstream River Flow.....	21
Withdrawal Zone Module.....	26
Ambient Module	27
Plant Performance Module	29
Cooling Tower Performance Module	30
Mixing Zone Module.....	32
Other Model Features	36
Diffuser Model Calibration.....	39
MODEL SIMULATIONS	48
Baseline Assumptions.....	48
Condenser Cooling Water Operation.....	48
Plant Water Routing.....	50
Cooling Tower Operation	51
Unit Operation	52
Equipment Service Loads	54
Diffuser Mixing	54
Ambient River Conditions	54
Baseline Results.....	55
Sensitivity Assumptions	62
Sensitivity Results.....	70
INDEPENDENT REVIEW	84
OTHER COOLING TOWER SCENARIOS.....	84
CONCLUSIONS.....	87
REFERENCES	92
APPENDIX A.....	94

LIST OF FIGURES

Figure 1. Site Location.....	3
Figure 2. BFN CCW Intake and Discharge Conduits.....	5
Figure 3. BFN CCW Submerged Multiport Diffusers.....	6
Figure 4. Geometry of Diffuser Ports	8
Figure 5. BFN CCW Gates for Cooling Tower Operation.....	9
Figure 6. BFN Cooling Towers	10
Figure 7. BFN Instream Monitoring Stations	13
Figure 8. BFN Hydrothermal Model	15
Figure 9. Deviations in Air Temperature and Natural Flow at Chattanooga.....	17
Figure 10. BFN Wet-Bulb Temperature for Late July 1993.....	18
Figure 11. Computed and Measured River Temperature Upstream of BFN for 1993	20
Figure 12. BFN Station 4 Temperature for Late July 1993	22
Figure 13. Computed Running 24-Hour Average River Flow at BFN for 1993	25
Figure 14. Computed Hourly River Flow at BFN for Late July 1993.....	26
Figure 15. Station 1 and Station 4 Running 24-Hour Average Temperatures for Summer 1986	28
Figure 16. Temperature Rise across BFN Condensers.....	30
Figure 17. BFN Cooling Tower Performance Curves	33
Figure 18. Two-Dimensional Plane Buoyant Jet Model for a Submerged Diffuser.....	34
Figure 19. Computed vs. Measured Temperatures for One-Unit Operation for Summer 1993 ..	41
Figure 20. Computed vs. Measured Temperatures for One-Unit Operation for Summer 1994 ..	42
Figure 21. Computed vs. Measured Temperatures for Two-Unit Operation for Summer 1999 ..	43
Figure 22. Computed vs. Measured Temperatures for Two-Unit Operation for Summer 2001 ..	44
Figure 23. Computed vs. Measured Temperatures for Two-Unit Operation for Summer 2002 ..	45
Figure 24. Computed vs. Measured Temperatures for Two-Unit Operation for Summer 2004 ..	46
Figure 25. Baseline (Case 0) Results for BFN Simulations.....	57
Figure 26. BFN Operation for 1993.....	58
Figure 27. BFN Operation for Late July 1993	59
Figure 28. BFN Cooling Tower Performance Curves with Normal and Reduced Capabilities ..	67
Figure 29. Effect of Condenser Cleanliness Factor on Condenser Temperature Rise.....	68
Figure 30. Instream Temperature Rises Computed by Unstratified and Stratified Models for ...	69
Figure 31. Range of Annual Cooling Tower Energy Loss for Sensitivity Cases	72
Figure 32. Range of Annual Derate Energy Loss for Sensitivity Cases.....	73
Figure 33. Range of Total Energy Loss for Sensitivity Cases.....	74
Figure 34. Average Energy Loss Per Year for Sensitivity Cases	77
Figure 35. Worst Year Energy Loss for Sensitivity Cases	82

LIST OF TABLES

Table 1. 24-Hour Average BFN Wet-Bulb Temperature for June, July, and August	17
Table 2. 24-Hour Average BFN Upstream River Temperature for June, July, and August.....	21
Table 3. 24-Hour Average River Flow at BFN for June, July, and August.....	24
Table 4. Difference in Water Temperature between Station 1 and Station 4	28
Table 5. BFN Cooling Tower Design Points and Operational Constraints	32
Table 6. RMS and Average Temperature Errors for January through December	47
Table 7. RMS and Average Temperature Errors for June, July, and August	47
Table 8. Baseline Assumptions for BFN Hydrothermal Modeling (Case 0).....	49
Table 9. Baseline (Case 0) Results for BFN Simulations.....	56
Table 10. Cases for Sensitivity Evaluations	63
Table 11. Results for Sensitivity Cases	71
Table 12. Total and Average Energy Loss for Sensitivity Cases	77
Table 13. Worst Year Total Energy Loss for Sensitivity Cases	82
Table 14. Derate Energy Loss for BFN Cooling Tower Scenarios	86

HYDROTHERMAL MODELING OF BROWNS FERRY NUCLEAR PLANT WITH UNITS 1, 2, AND 3 AT EXTENDED POWER UPRATE

INTRODUCTION

The Tennessee Valley Authority (TVA) Browns Ferry Nuclear Plant (BFN) contains three boiling water reactor electric generating units. Only two of the units presently are in operation. For each unit, condenser cooling water (CCW) from Wheeler Reservoir on the Tennessee River is used to remove waste heat from the plant steam cycle. In this process, the plant is responsible for meeting environmental regulations for the safe dissipation of the waste heat in the river. The environmental regulations, administered by the State of Alabama, are found in the plant National Pollutant Discharge Elimination System (NPDES) permit. Those related to the waste heat include thermal limits for the maximum river temperature downstream of the plant and the maximum rise in river temperature from upstream to downstream of the plant. Under most conditions the NPDES permit allows the waste heat from BFN to be assimilated in the river by once-through, or open-mode, cooling. However, when the river becomes thermally stressed, the plant must be operated in helper-mode, wherein a portion of the waste heat is assimilated in the atmosphere by routing part of the plant thermal effluent through cooling towers. If the thermal conditions of the river and/or atmosphere are such that the cooling towers are unable to remove a sufficient amount of heat, the plant must be derated to meet the NPDES requirements.

TVA currently is in the process of restoring the third unit at BFN to service. In addition, the maximum power level of all three units will be uprated to 120 percent of their original level. As a result, the amount of waste heat produced by the plant will increase substantially compared to current conditions with two units. To help TVA make optimal decisions regarding the cooling system, the purpose of this study is to provide information as to the potential impacts of the additional waste heat on the operation of the plant. The impacts will emerge as higher river temperatures downstream of the plant. To satisfy the thermal limits of the NPDES permit, these, in turn, will result in a larger amount of cooling tower operation and plant derates. In this manner, the objective of the study is to estimate, for different conditions of the plant and river, the potential range of energy losses to the power system due to cooling tower operation and plant derates. Meaningful estimates of the loss of energy in unit derates is of primary importance in decisions regarding TVA investment for cooling system upgrades.

In the study, a hydrothermal model has been used to estimate energy losses by simulating the operation of BFN for a period of time encompassing a range of river flows and meteorological conditions. Historical data are used for the hourly ambient river temperature upstream of the plant and site meteorology. Hourly river flows are derived from a flow routing model for Wheeler Reservoir. With this information, the BFN hydrothermal model includes components to

estimate the plant intake temperature (withdrawal zone), the temperature rise across the plant condensers (plant performance), the cooling tower discharge temperature (cooling tower performance), and the river temperature downstream of the plant (diffuser performance). Based on the NPDES thermal limits, specific procedures are included in the model to decide the process for placing cooling towers in and out of service and the process for derating and returning the units to full power (i.e., open-mode vs. helper-mode vs. derate-mode). A tracking module is used to accrue the amount of energy loss incurred for tower operation and unit derates.

Described in this report are the major aspects of the hydrothermal modeling study. Background information is given for the basic conditions of the site and the design and operation of the BFN CCW system. Data are presented for the site meteorology, river ambient water temperature, and ambient river flow. In the study, river flows are based on a new operating policy for the TVA reservoir system implemented in May 2004. The overall methodology of the study is described in detail, as well as the major components and processes of the BFN hydrothermal model. Of particular importance is the model component for diffuser performance. In previous studies the diffuser performance was evaluated using a thermal dilution algorithm based on a uniform ambient river temperature. In the current study an algorithm is used that incorporates the impact of a thermally stratified ambient. The method and results for the model calibration are given.

Model simulations are performed based on a historical period of BFN meteorology and TVA river system hydrology. The baseline conditions for the simulations assume the BFN cooling system includes a new 20-cell cooling tower, identified as the TVA preferred alternative in the Final Supplemental Environmental Impact Statement (FSEIS) for Operating License Renewal (TVA, 2002). Sensitivity simulations are made based on the uncertainty of key model assumptions. In addition to baseline conditions, model simulations also are performed for a number of scenarios for the plant cooling towers. The study results are summarized in terms of the expected frequency of cooling tower and derate events and the related megawatt hours (MWh) of energy loss. Conclusions focus on key results from the simulations, areas of significant uncertainty, and potential options for improvements.

BACKGROUND

Basic Site Conditions

BFN is located in north-central Alabama on Wheeler Reservoir at Tennessee River Mile 294.0. The plant is about 55 miles downstream of Guntersville Dam (GUH) and 19.1 miles upstream of Wheeler Dam (WEH), as shown in Figure 1. About 13 miles upstream of BFN, near the city of Decatur, Alabama, Wheeler Reservoir begins to expand from a section characterized by narrow, riverine conditions to one including a main channel with wide adjacent overbanks. At BFN the

main channel is about 30 feet deep and 2000 feet wide and the overbanks are about 5000 feet wide and from 3 to 6 feet deep.

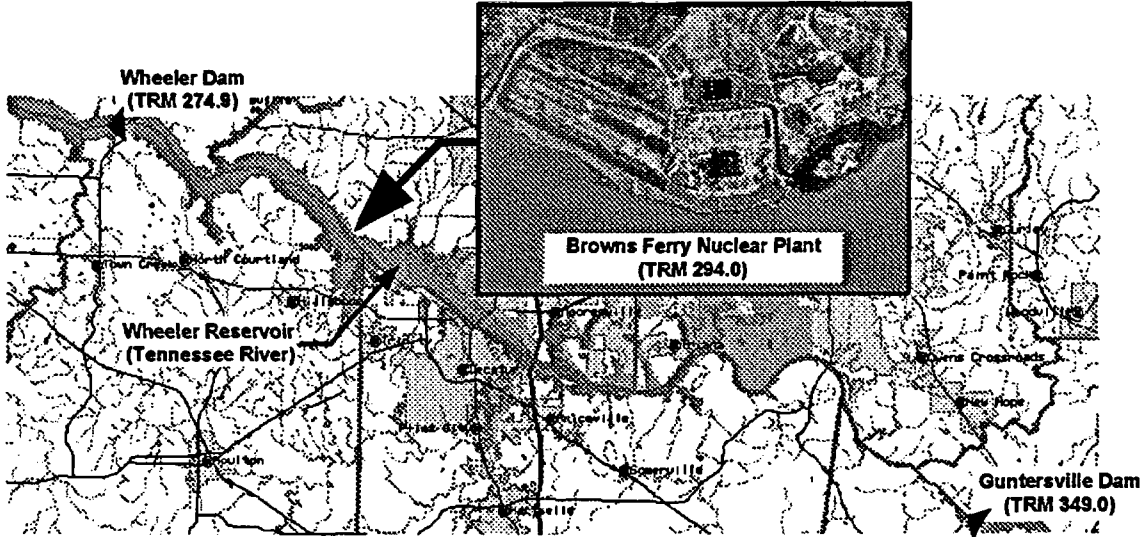

Figure 1. Site Location

The river flow at BFN depends primarily on discharges from GUH and WEH. Flows from TVA dams are scheduled to meet the multipurpose objectives of the TVA river system. In general, on an annual basis, this leads to higher flows in the winter and spring and lower flows in the summer and fall. Based on historical data from 1985 to 2004 for GUH and WEH, the average flow past BFN for December through May is about 55,000 cfs, whereas that for June through November is about 35,000 cfs. On a daily average basis, flows past BFN can be much higher and much lower than these average values, and even more so on an hourly average basis. Hourly releases from GUH and WEH are made throughout the day in peaking patterns that seek to optimize the generation assets at the dams. In the summer, this typically leads to high river flows in the afternoon and early evening, and low river flows in the late evening and early part of the day. In the winter, peak flows are common both in the mid-morning and late afternoon, with lower flows in the intervening periods. The peaking patterns at GUH and WEH can create sloshing in Wheeler Reservoir wherein within a day the hourly flow at BFN can vary from over 100,000 cfs in the downstream direction to perhaps more than 10,000 cfs in the upstream direction. Additional information about Wheeler Reservoir and the operation of GUH and WEH can be found at the following web sites:

- http://www.tva.com/sites/sites_ie2.htm,
- <http://www.tva.com/sites/wheeler.htm>, and
- <http://www.tva.com/river/lakeinfo/index.htm>

Water temperature patterns in Wheeler Reservoir are constantly changing in response to varying meteorology and hydrology. The most important factors producing these changes are the air temperature, humidity, wind speed, solar radiation, and patterns of flow in the river. Natural, seasonal water temperatures vary from about 35°F in the middle of the winter to near 90°F in the warmest part of the summer. The water column upstream of BFN is usually fully mixed in the winter with weak thermal stratification possible in the spring, summer, and fall. The stratification is weak in that it usually appears and disappears on a daily basis in response to the diurnal variations in meteorology. In the spring and fall the stratification can yield a peak difference in temperature of about 2°F between the surface and bottom of the reservoir, whereas in the summer, the peak difference can exceed 6°F. Other spatial variations in temperature occur between the main channel and overbank portions of the reservoir. In general, the overbank portions are more responsive to changing meteorology, yielding warmer temperatures in the summer and cooler temperatures in the winter.

Additional information concerning flows and temperatures in the vicinity of BFN is presented later in discussions related to the plant withdrawal zone and diffuser mixing zone.

Condenser Cooling Water System

The BFN condenser CCW is described in the plant Final Safety Analysis Report (TVA, 2003). Only a brief description of the major CCW components and configuration of flow is presented here. Additional information concerning the specifications for the various components is presented later in discussions related to the modeling assumptions.

The CCW flow through the plant is shown in Figure 2. Water is withdrawn from Wheeler Reservoir by an intake pumping station containing three CCW pumps per unit (i.e., nine pumps total). For each unit, the pumps operate in parallel to deliver the flow to an intake tunnel that supplies the water to the condenser in the plant turbine building. Each condenser contains six parallel waterboxes. The flow from the waterboxes enters a discharge tunnel that carries the water out of the turbine building.

In open-mode operation, the discharge tunnel for each unit delivers the CCW effluent to a submerged multiport diffuser located on the bottom of the main channel of Wheeler Reservoir and about 1000 feet downstream of the intake pumping station. The basic arrangement of the diffusers is shown in Figure 3. The discharge ports for each diffuser are found in a section about 600 feet long. The most upstream diffuser is that for Unit 2 and has a diameter of 20.5 feet. The discharge section for the Unit 2 diffuser is situated in the portion of the main channel opposite of the plant. The middle diffuser is that for Unit 1 and has a diameter of 19.0 feet. The discharge

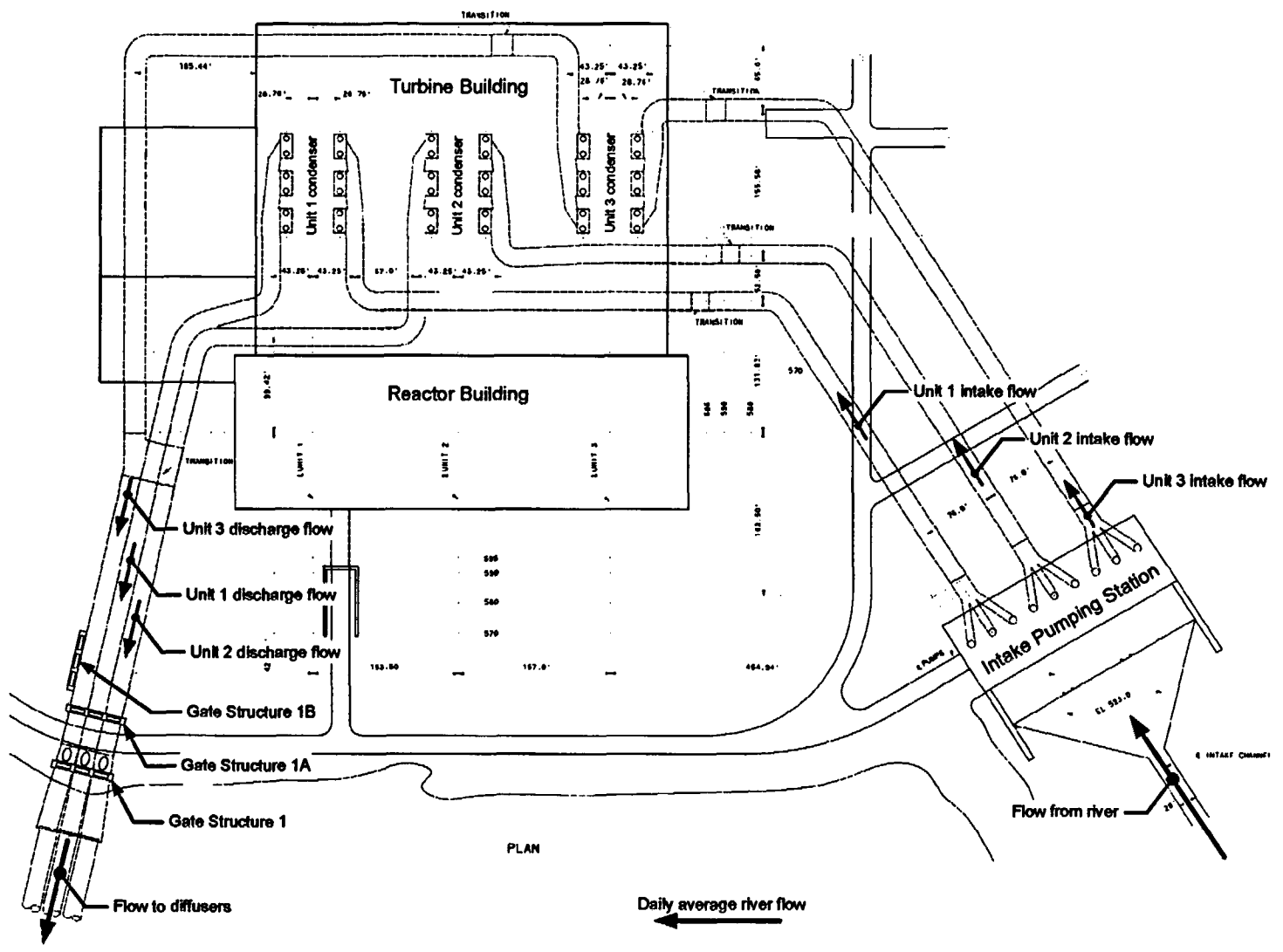

Figure 2. BFN CCW Intake and Discharge Conduits

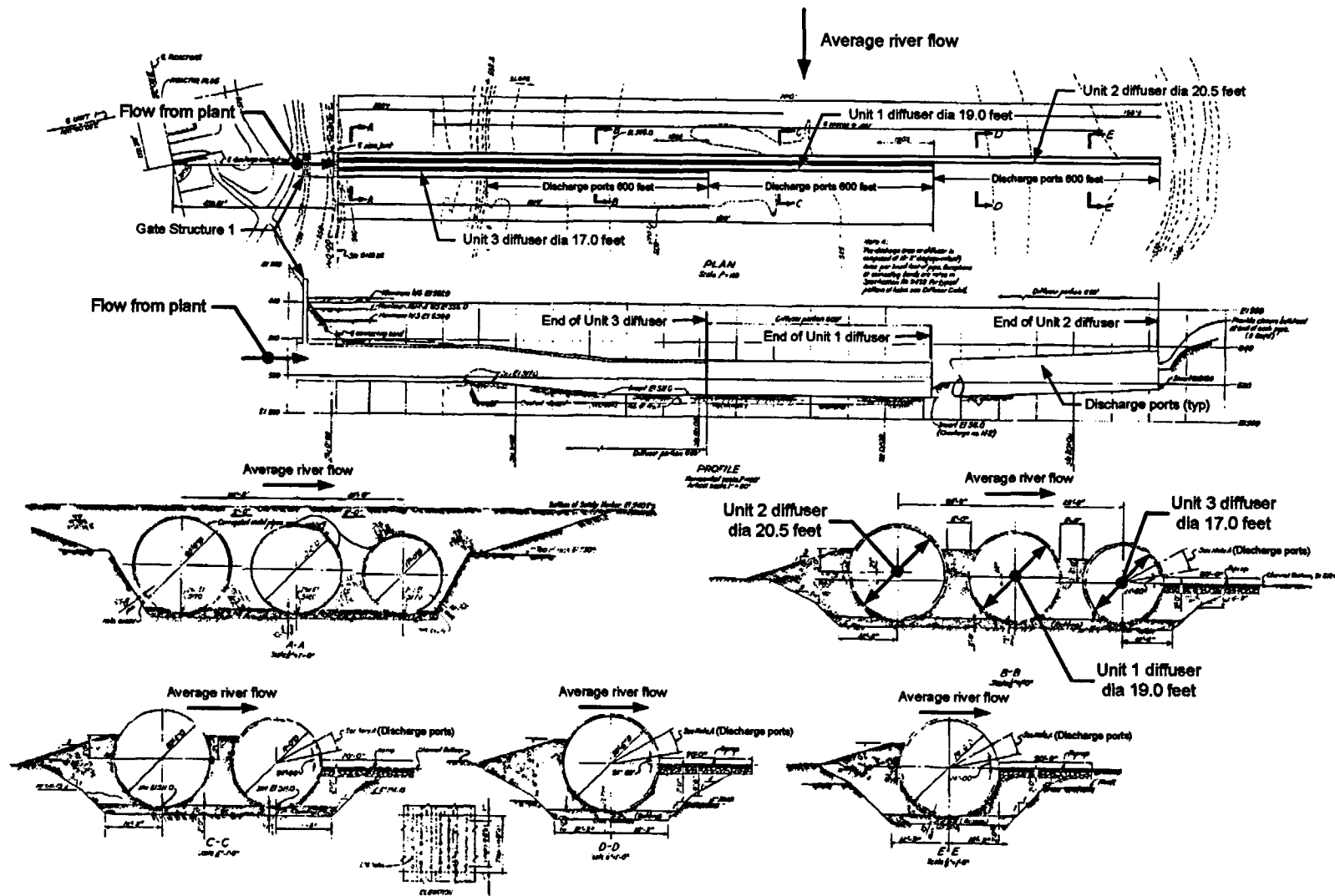

Figure 3. BFN CCW Submerged Multiport Diffusers

section for the Unit 1 diffuser is situated in the middle of the main channel. The most downstream diffuser is that for Unit 3 and has a diameter of 17.0 feet. The discharge section for the Unit 3 diffuser is situated in the portion of the main channel directly adjacent to the plant.

The geometry of the diffuser discharge ports is shown in Figure 4. The ports are located in the upper, downstream quadrant of the diffuser conduits. To promote mixing, this location releases the thermal effluent in the wake of the diffuser conduits (i.e., based on the average river flow). The port spacing provides about thirteen 2-inch diameter holes per foot of diffuser length, yielding a total of about 7800 holes per diffuser. Information about the hydraulic and hydrothermal characteristics of the BFN diffusers is given by Vigander et al. (1970) and Harleman et al. (1968).

The CCW effluent from one or more of the BFN units can be treated using cooling towers by adjusting gates in the CCW discharge tunnels. The basic arrangement of the gates and cooling towers is shown in Figure 5 and Figure 6. To place a unit on towers, the corresponding gate in Gate Structure 1A is closed to divert the condenser effluent through Gate Structure 1B and into a tunnel that carries the flow to the cooling towers. Gate Structure 1B contains a stop log arrangement and is normally open. The profile of the tunnel to the cooling towers includes a high point, or siphon, to prevent flow to the towers under normal open-mode operation. When a unit is placed on towers, a vacuum priming system is provided to start and maintain the flow over the tunnel siphon.

From the cooling tower tunnel, the CCW effluent enters a warm water channel extending the full length of the tower field. The original field included six cooling towers; however, due to a fire in 1986 that destroyed tower 4, the site currently contains only five cooling towers. In the warm water channel, a pumping station is provided for each cooling tower to withdraw and lift the flow to the tower distribution channels. After passing through the fill, the discharge from each cooling tower enters a cold water channel extending around the tower field. The cold water channel returns the treated flow to Gate Structure 1. The corresponding gate in Gate Structure 1 is opened to allow the treated flow to pass into the diffuser for the unit that has been placed on cooling towers (see Figure 5). This type of operation, wherein the CCW effluent passes through cooling towers and is returned to the river, is known as helper-mode operation. In reality, all of the gates in Gate Structure 1 are usually kept open for all modes of operation. Thus, if a unit is placed in helper-mode, the flow in the cold water return channel can enter any of the three diffusers. However, due to the diffuser head for units in open-mode, it is anticipated that the flow in the cold water return channel will enter primarily the diffusers of those units that are either idle or in helper-mode operation.

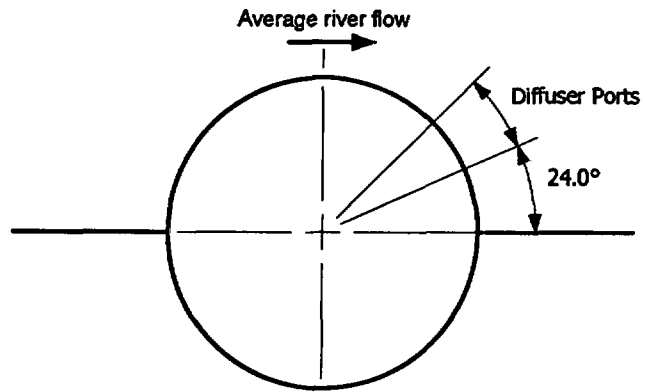

(a) location

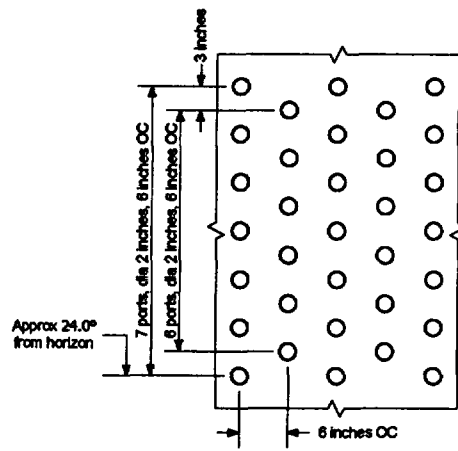

(b) port spacing

Figure 4. Geometry of Diffuser Ports

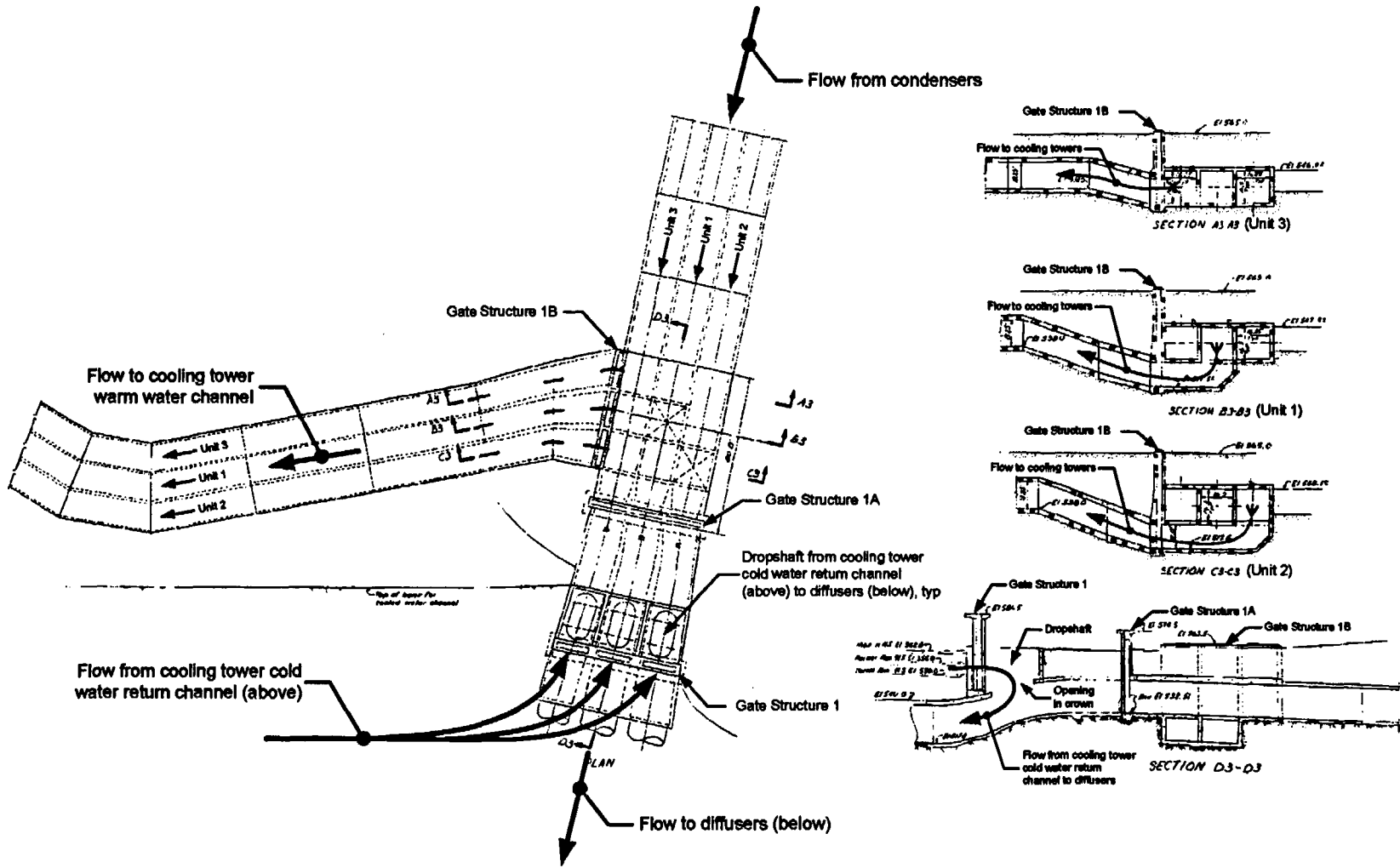

Figure 5. BFN CCW Gates for Cooling Tower Operation

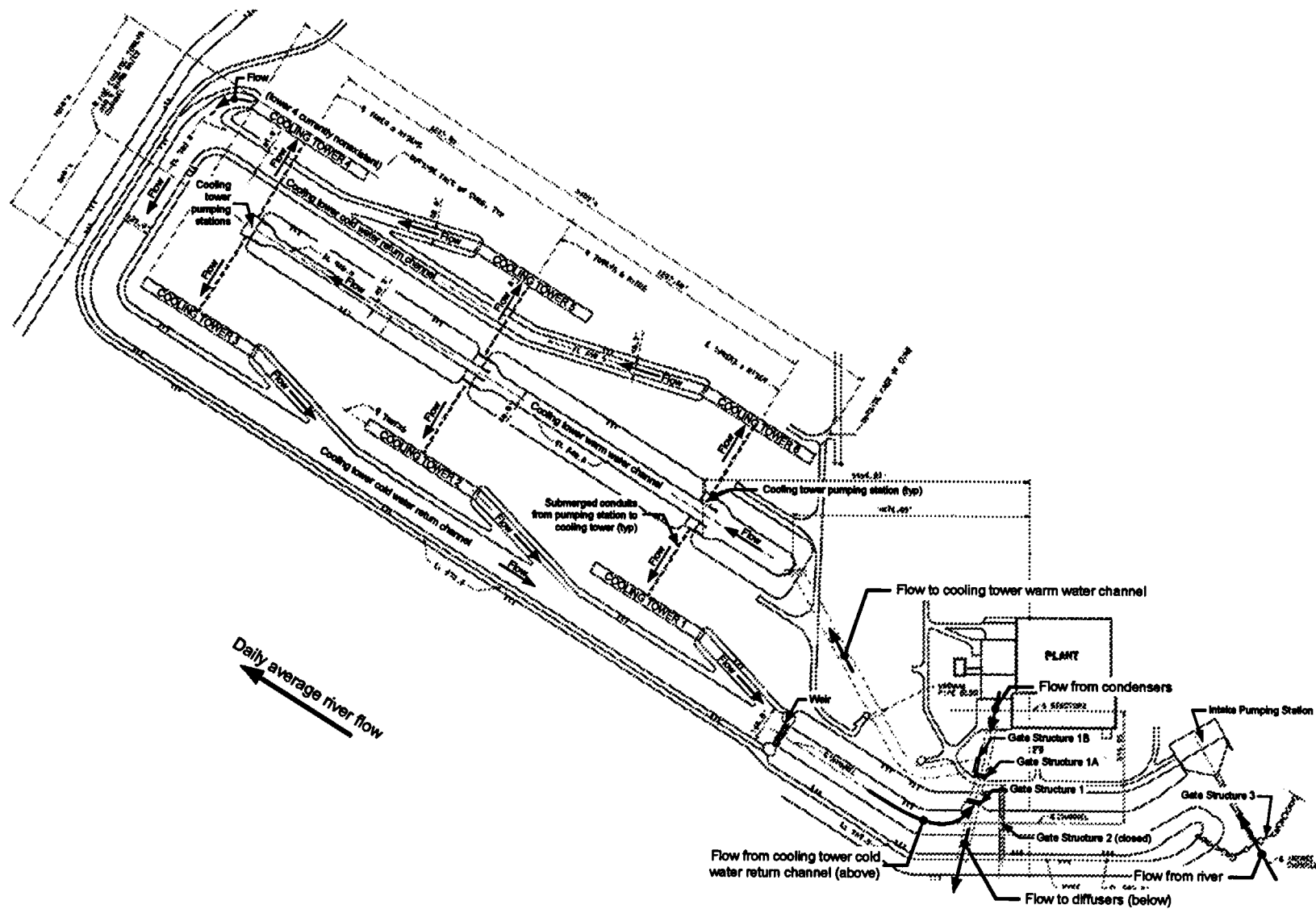

Figure 6. BFN Cooling Towers

Note in Figure 6 that the cold water return channel also includes a control structure known as Gate Structure 2. In helper-mode operation Gate Structure 2 is closed, forcing all flow in the cold water return channel through Gate Structure 1. If Gate Structure 1 is closed and Gate Structure 2 is opened, the treated CCW effluent will be returned to the intake pumping station, placing the plant in closed-mode operation. However, although the plant physically can be aligned for such, the current status of the plant cooling systems will not allow the operation of BFN in closed-mode.

Another component of the CCW system shown in Figure 6 is Gate Structure 3. This structure separates the main body of Wheeler Reservoir from the forebay of the intake pumping station and contains three gates that can be adjusted up and down to provide skimming of the flow. In general, the gates are maintained in a position as low as possible without submerging the top of the gates below the water surface. This promotes a withdrawal from the cooler part of the reservoir water column while preventing floating debris from entering the intake forebay.

NPDES Water Temperature Limits

The instream water temperature limitations and monitoring requirements for the BFN diffuser discharge are specified in the plant NPDES permit (ADEM, 2000). The following limitations are given:

- The downstream 24-hour running average river temperature shall not exceed 90°F,
- The downstream 1-hour running average river temperature shall not exceed 93°F, and
- The 24-hour running average river temperature rise from upstream to downstream of the plant shall not exceed 10°F.

In recognition of the extreme natural heating that can occur in Wheeler Reservoir, the permit also states that for situations where the ambient river temperature exceeds 90°F, the downstream 24-hour running average river temperature may also exceed 90°F, as long as the 24-hour temperature rise is zero. That is, the impact of the plant waste heat on the river must be negligible, so that the downstream temperature is the same as the upstream temperature (i.e., for the running 24-hour average values). It should be emphasized that these limits are higher than the state standards for the Tennessee River, which are 86°F for the maximum instream temperature and 10°F for the maximum instream temperature rise. The higher limits were granted in the mid 1980s by a variance obtained via Section 316(a) of the federal Clean Water Act of 1972.

The locations of the instream water temperature stations used to monitor the NPDES limits are shown in Figure 7. Station 4 is the primary ambient temperature monitor and is located about 3.8 miles upstream of the diffusers on the left-hand side (i.e., looking downstream) of the main channel of the reservoir. If Station 4 inadvertently drops out of service, Station 14 is provided as a backup monitor. Station 14 is located about 2.1 miles upstream of the diffusers and is situated on the right-hand side of the main channel. To measure downstream temperatures, three monitors are provided, one each for Unit 1, Unit 2, and Unit 3. All three stations are about 2400 feet downstream of the diffusers. Station 1 is located downstream of Unit 1 (i.e., middle diffuser), Station 17 downstream of Unit 2 (i.e., outboard diffuser), and Station 16 downstream of Unit 3 (i.e., shoreline diffuser).

All instream temperature limits are applied at a depth of 5 feet. Sensor readings from the temperature stations are collected every 15 minutes—at about the top of the hour and 15, 30, and 45 minutes thereafter. The 15-minute upstream temperature is assigned as the 15-minute reading from Station 4 (or Station 14, if Station 4 is out of service). Per the NPDES permit, the downstream temperature includes an average of the measurements from the downstream temperature stations, but only those below active diffusers. Thus, under current conditions, with only Unit 2 and Unit 3 in service, the 15-minute downstream temperature is computed as the average of measurements from Station 17 (Unit 2) and Station 16 (Unit 3), if both units are operating in open-mode. When Unit 1 is restored to service, the measurements from all three downstream stations will be averaged for the downstream temperature. It also is important to note that the status of a diffuser is based solely on whether or not it is discharging a significant amount of effluent to the source waterbody, not on whether or not the effluent is thermally loaded. Thus, if a unit is shut down so that no thermal power is being created, and yet the CCW system is in service and operating in open-mode, the corresponding diffuser would be classified as active.

The 15-minute temperature rise is computed as the difference between the 15-minute downstream temperature and the 15-minute upstream temperature. At a given point in time, 24-hour running average values for the compliance parameters are determined as the average of the most recent and previous ninety-five 15-minute readings (i.e., for the 24-hour average river temperature and 24-hour average river temperature rise).

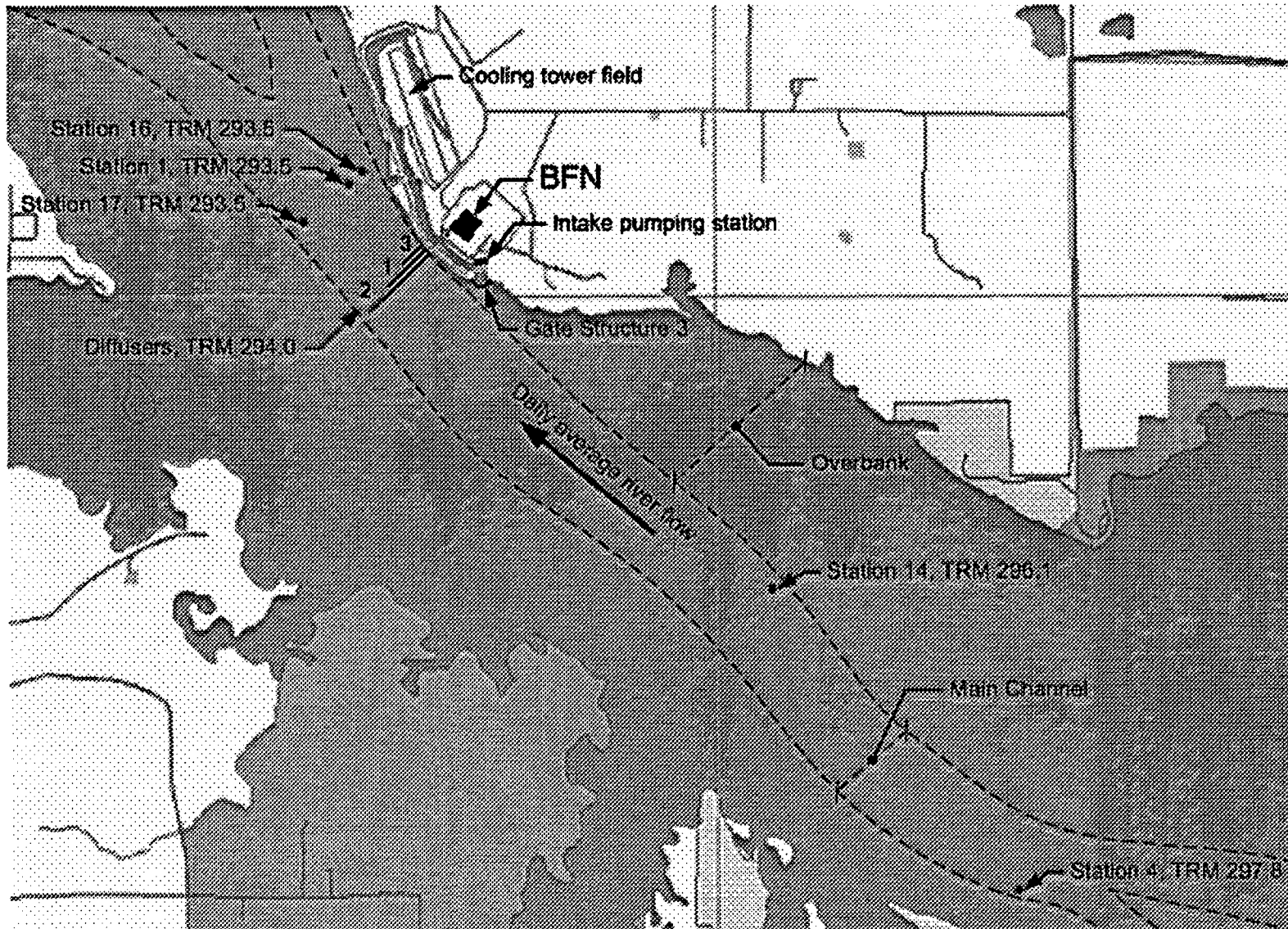

Figure 7. BFN Instream Monitoring Stations

The 1-hour running average downstream temperature is determined as the average of the most recent and previous three 15-minute readings. In contrast to the limit for the downstream 24-hour running average temperature (i.e., 90°F), the limit for the downstream 1-hour running average temperature (i.e., 93°F) applies individually to any one of the downstream temperature monitors, whether or not the corresponding diffuser is active. Thus, in monitoring the operation of the plant, tracking for the 1-hour running average temperature is performed for each of the downstream temperature stations at all times (i.e., Station 1, Station 16, and Station 17).

METHODOLOGY

Model Overview

The primary components of the BFN hydrothermal model are shown schematically in Figure 8. The basic data required for the model include meteorology, upstream river temperature, and upstream river flow. The upstream river temperature and flow are used by the withdrawal zone module to define the intake conditions for the plant, and by the ambient module to define ambient conditions for the diffuser effluent. Based on the intake temperature and flow, the plant performance module determines, for each unit, the generation (MWe) and the temperature of the flow exiting the condenser. In open-mode, the discharge conditions from the plant performance module become the inflow conditions for the mixing zone module. Based on the diffuser inflow conditions and ambient river conditions, the mixing zone module estimates, for each active diffuser, the instream temperature at a depth of 5 feet and distance corresponding to the downstream temperature stations (i.e., 2400 feet below the diffusers). The computed downstream temperatures, in turn, are used to determine the NPDES compliance parameters—the 1-hour and 24-hour running average downstream temperatures, and the 24-hour running average temperature rise.

If one or more of the compliance parameters are found to threaten an “action level”, cooling tower operation is initiated. Note that since the BFN units can independently be placed on cooling towers, the operation of the plant can occur in a combined fashion, with some units in open-mode and some units in helper-mode. For those units in helper-mode, the discharge conditions from the plant performance module become the inflow conditions for the cooling tower performance module. Meteorology also is required as an input for the cooling tower module (wet-bulb temperature). The cooling tower performance module determines not only the temperature and flow of the discharge exiting the cooling towers, but also the amount of energy required to operate the cooling tower equipment (i.e., lift pumps and fans). For those units in helper-mode, the discharge conditions from the cooling tower performance module serve as the inflow conditions for the mixing zone module.

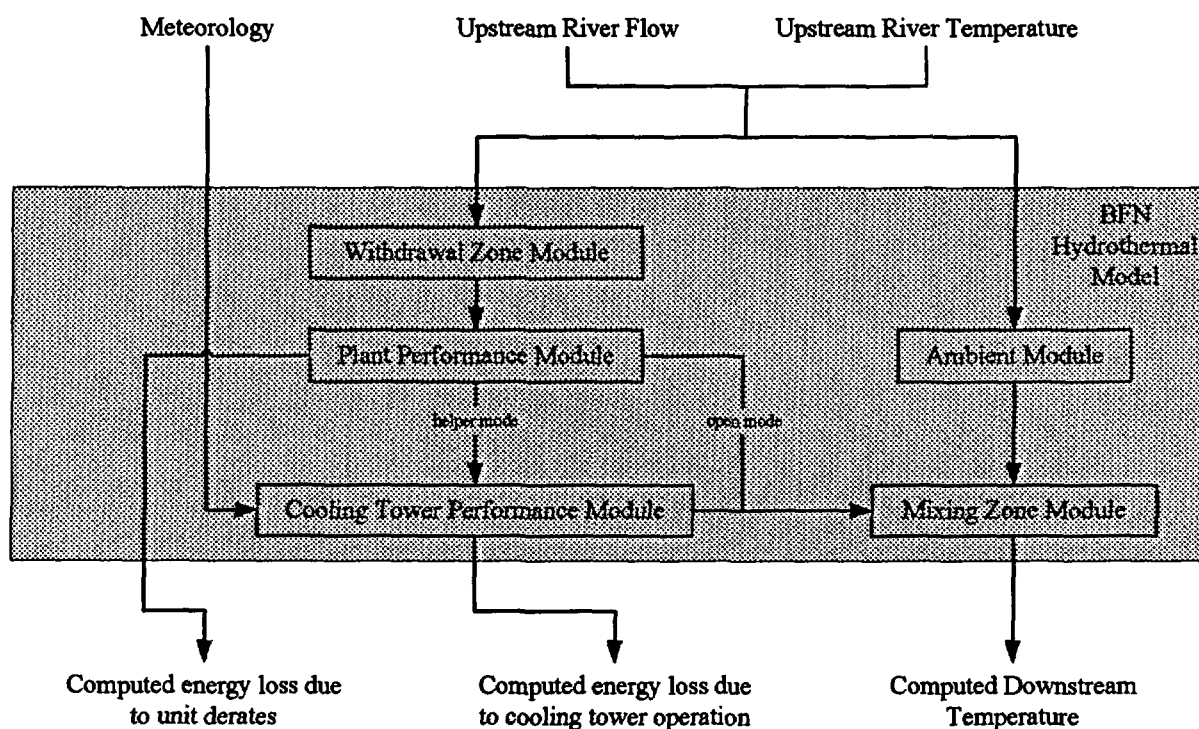

Figure 8. BFN Hydrothermal Model

If all units have been placed in helper-mode and an NPDES limit is still threatened, generation is curtailed by the model, creating a derate. In such situations, the plant performance module is used not only to determine the reduced condenser discharge temperature, but also the magnitude of derate for the affected units.

Additional details about specific input data and model components are provided in the following sections. Implicit in Figure 8 is a “supervisory control” module, needed to determine the process of placing cooling towers in and out of service, and the process of derating and returning units to full power. Specific key information regarding these processes is presented later in discussions related to baseline assumptions for the hydrothermal model.

Simulation Period

Simulations with the BFN hydrothermal model were performed based on the 20-year period from 1985 to 2004. This selection was made primarily as a result of the characteristics of the upstream river temperature. As discussed in more detail later, it was decided to use historical data for the upstream river temperature. Such data is available only from 1969, a few years before BFN began operation. However, prior to 1985, GUH and WEH were operated in a manner much differently than after 1985. In part, this was because prior to 1985, the NPDES

instream temperature limits for BFN were much more restrictive than those after 1985. For example, the limit for the maximum temperature downstream of the plant was 86°F rather than the current value of 90°F. Thus, prior to 1985, to minimize energy losses due to BFN derates, special releases from GUH and WEH occasionally were made to help dilute the plant waste heat, making the conditions of Wheeler Reservoir unrepresentative of the potential future conditions of the reservoir.

The general hydrothermal characteristics of years 1985 to 2004 can be evaluated by examining the basic statistical properties of the historical air temperature and runoff in the region. Since energy losses due to cooling tower operation and derates occur almost exclusively in the summer, focus is given to months June through August. Given in Figure 9 is a chart showing the deviation in mean air temperature and deviation in mean natural flow for the months June through August for years 1948 to 2004 in Chattanooga. Chattanooga is chosen for the analysis because it resides as a central control point in the Tennessee River system. The air temperature was obtained from airport data, whereas the flow was obtained from a model of the Tennessee River system with simulated undeveloped (natural) conditions. As shown, the period from 1985 to 2004 is found to include years in all four quadrants of the chart (i.e., Warm/Wet, Warm/Dry, Cool/Dry, and Cool/Wet), and contains the warmest, wettest, and driest years of the 56-year record. Overall, the mean natural summertime flow for 1985 to 2004 is roughly the same as that of the entire period from 1948 to 2004. However, the mean air temperature is about 0.6°F warmer. A closer examination of the airport data shows that this difference occurs as a result of the period from about 1955 to 1975, which was consistently cooler than other periods of the record, including years 1985 to 2004. Assuming the airport data is good (e.g., free of error due to changes in instrumentation), this would suggest that the overall results of the BFN hydrothermal study could perhaps be biased high compared to results from simulations spanning the entire period from 1948 to 2004. However, this is considered acceptable in light of the uncertainty of the type of meteorology that the region will experience in the next 30 years of BFN operation.

Meteorology

The only meteorological parameter needed for the hydrothermal model is wet-bulb temperature, required to determine the cooling tower approach when BFN units are in helper-mode. The data for wet-bulb temperature used in the study was derived from actual hourly measurements at BFN. Focusing again on June, July, and August, when cooling tower operation is most likely to occur, the basic statistical properties of wet-bulb temperature for each summer of the simulation period are given in Table 1. Provided in Figure 10 is an example of the diurnal variation in hourly wet-bulb temperature for observations in 1993.

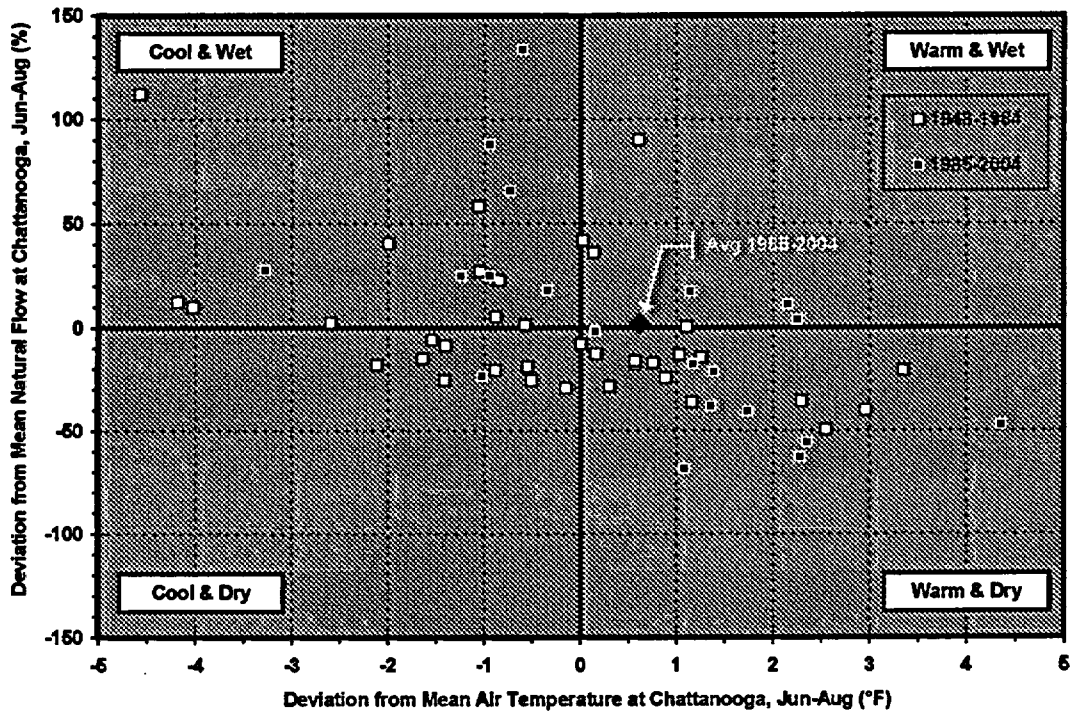

Figure 9. Deviations in Air Temperature and Natural Flow at Chattanooga

Table 1. 24-Hour Average BFN Wet-Bulb Temperature for June, July, and August

Year	Min (°F)	Avg (°F)	Max (°F)
1985	53.7	70.6	75.2
1986	55.7	71.8	78.6
1987	60.0	71.1	76.8
1988	52.1	70.0	78.0
1989	57.3	71.4	76.9
1990	58.7	70.5	75.8
1991	61.6	71.0	75.8
1992	55.4	69.7	77.1
1993	55.0	72.3	77.7
1994	64.8	71.2	76.0
1995	56.4	71.4	77.9
1996	61.0	70.5	75.9
1997	59.2	70.2	78.6
1998	54.7	72.5	77.1
1999	59.5	71.8	78.6
2000	56.8	71.0	76.8
2001	60.6	70.9	77.4
2002	62.4	72.0	77.5
2003	57.8	70.8	75.8
2004	56.3	70.2	75.6
1985-2004	52.1	71.0	78.6

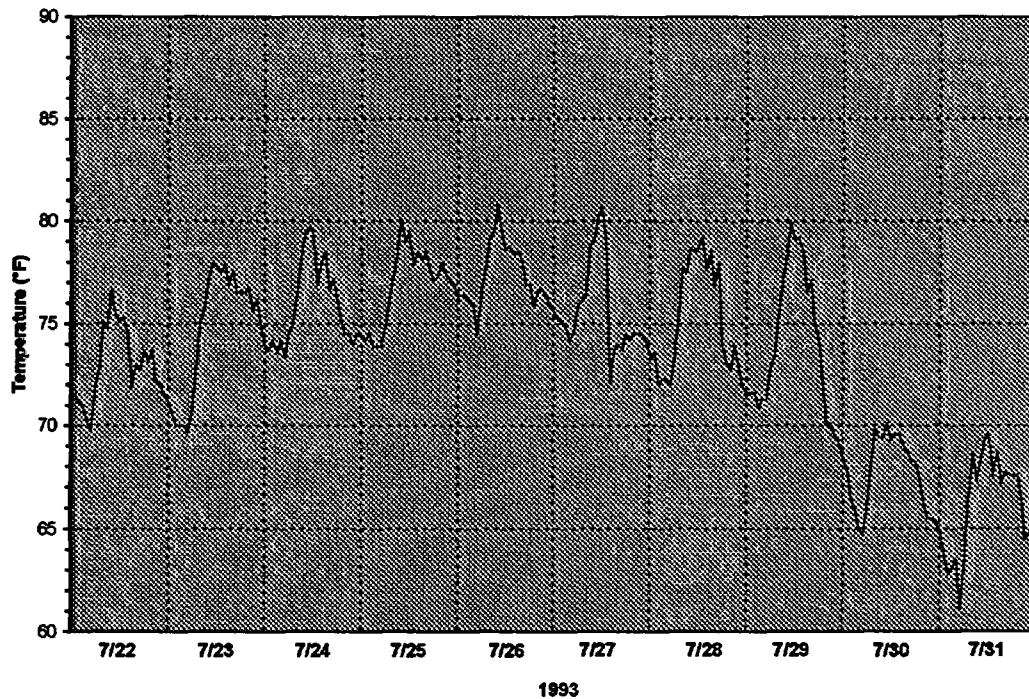

Figure 10. BFN Wet-Bulb Temperature for Late July 1993

Upstream River Temperature

On May 19, 2004, the TVA Board of Directors approved a new policy for operating the Tennessee River system. The policy is based on a comprehensive review of the system known as the TVA Reservoir Operations Study (ROS). Details of the review are provided at http://www.tva.com/feature_rostudy/index.htm. Among the changes, the new policy includes subtle modifications in the flow requirements at selected sites throughout the river system. Since these modifications will endure for many years to come, it is important that the BFN hydrothermal evaluations consider river flows and ambient river temperatures consistent with the new operating policy. As part of the ROS, the statistical properties of the expected reservoir releases were determined by a scheduling model that routes historical runoff through the river system based on the objectives of the operating policy. The process of determining the river flows at BFN from the ROS releases at GUH and WEH is discussed in the next section. Here, the focus is the ambient water temperature.

In the ROS, water quality impacts, including temperature, were evaluated for all major reservoirs in the TVA river system. The temperatures in Wheeler Reservoir were evaluated using a water quality model known as BETTER (Shiao et al., 1993; Bender et al., 1990). Whereas the BETTER model is usually suitable for evaluating overall reservoir behavior, as in the ROS, it is not necessarily suitable for examining the detailed behavior at site-specific locations, such as BFN. In part, this is due to the fact that BETTER is limited to a two-dimensional, laterally averaged formulation containing advection processes governed solely by mass-balance. In contrast, the local hydrothermal behavior of the reservoir at BFN is heavily influenced by three-dimensional, momentum-dominated processes. This is particularly true in the summer, when significant temporal and spatial interactions occur as a result of peaking operations, stratification, and main channel-overbank diversity. Under these conditions, results from the BETTER model could not be used to predict, in an absolute manner, the ROS-related temperature upstream of BFN. However, since BETTER does account for the basic mechanisms for reservoir heat transfer, it was considered adequate as a scaling tool to examine the potential magnitude of change in ambient temperature due to the ROS operating policy.

Examples of the computed running 24-hour average river temperature upstream of BFN obtained by BETTER are shown in Figure 11. The results are for 1993 and include the temperature based on the ROS releases and the temperature based on historical releases. The temperatures are for the reach of Wheeler Reservoir containing BFN Station 4. The historical data for Station 4 is provided for comparison. All temperatures are for a depth of 5 feet, corresponding to the depth specified in the BFN NPDES permit for compliance with the instream temperature limits. Note that the running 24-hour average temperature is scrutinized in the analysis because the operation of cooling towers and plant derates are triggered by temperature variations at this scale. As shown, the computed temperature using BETTER with historical flows reproduces the general seasonal patterns measured at Station 4, and in many cases shorter-term variations caused by passing weather systems (e.g., temperature excursions lasting one or two weeks). But whereas the model reproduces the overall time-scale of temperature variations, it often does not do the same for the magnitude. Of most importance are the summer months. As shown in Figure 11, and found in nearly all of the years examined, the BETTER model consistently overpredicts the river temperature in the summer. Thus, if used in the BFN hydrothermal model, the temperature obtained by BETTER would significantly overpredict the expected amount of energy losses due to cooling tower operation and unit derates.

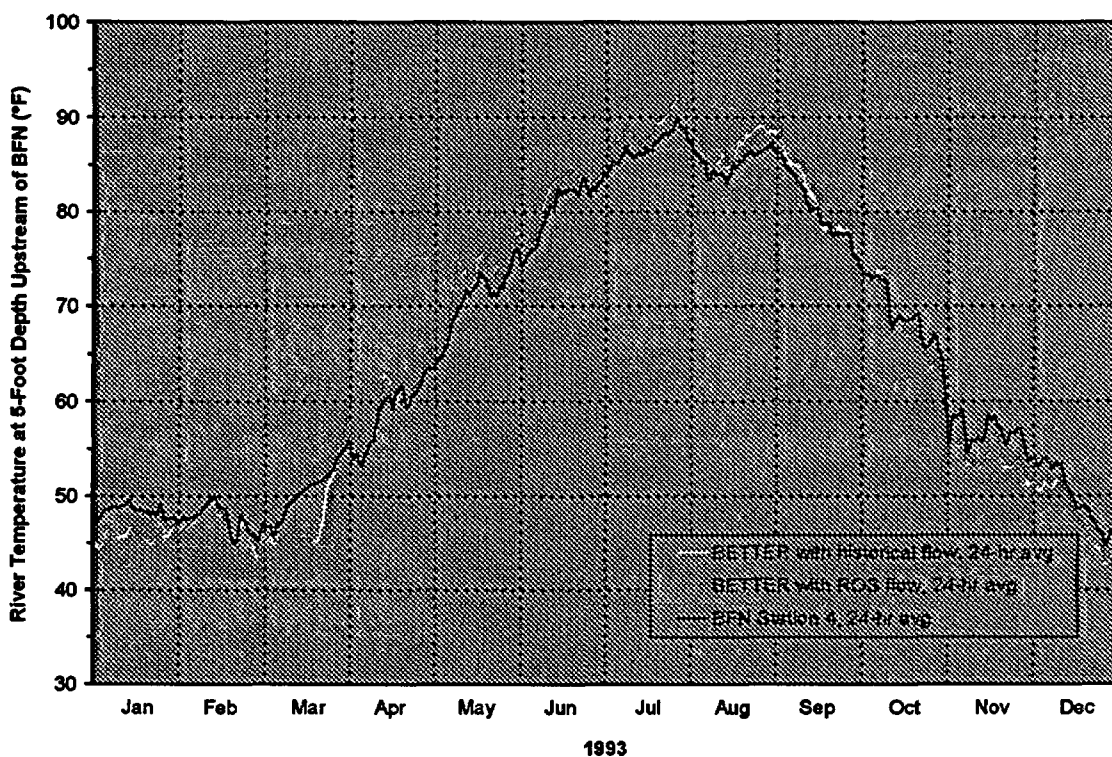

Figure 11. Computed and Measured River Temperature Upstream of BFN for 1993

Comparing now the BETTER results using the ROS releases with those using historical releases, the computed 24-hour average river temperatures for the two cases are only slightly different. A detailed examination of the results show that on the average, the running 24-hour average river temperature upstream of BFN with the ROS releases would be only of magnitude 0.2°F warmer than that with historical releases (i.e., at the 5-foot depth). The same is also found to be true for the hourly river temperature. This scale of change falls within the level of uncertainty of the BETTER model, as well as the accuracy of the instrumentation currently used to measure the instream temperatures (e.g., $\pm 0.5^\circ\text{F}$). As a result, it is anticipated that changes in river flow brought about by the ROS will have only a minor impact on the running 24-hour average temperature upstream of BFN. Under these conditions, the best estimate of the upstream temperature to be used in the hydrothermal model is considered to be that represented by the historical measurements at Station 4 from 1985 to 2004 (i.e., without modifications). The basic statistical properties of the upstream temperature for each summer of the simulation period are given in Table 2. Note that these properties are for Station 4 at a depth of 5 feet.

Table 2. 24-Hour Average BFN Upstream River Temperature for June, July, and August

Year	Min (°F)	Avg (°F)	Max (°F)
1985	76.5	82.0	86.2
1986	76.4	83.6	88.9
1987	79.8	84.1	86.9
1988	75.3	82.7	87.4
1989	74.4	79.8	85.2
1990	73.9	83.2	86.8
1991	79.4	84.4	88.5
1992	71.9	80.5	85.3
1993	74.3	84.2	90.0
1994	74.8	82.0	85.8
1995	76.6	84.0	88.6
1996	75.7	82.6	86.6
1997	68.8	80.3	88.2
1998	77.6	83.7	87.0
1999	75.7	83.6	89.3
2000	77.2	83.8	88.0
2001	73.1	82.1	86.2
2002	74.9	84.2	88.3
2003	72.2	81.5	86.6
2004	78.0	82.2	86.3
1985-2004	68.8	82.7	90.0

Note: Temperature from measurements at a depth of 5 feet at BFN Station 4

As discussed in more detail later, the mixing zone module for the hydrothermal model includes the impact of stratification in the ambient flow. Thus, the full temperature profile from Station 4 was used in the BFN simulations. Provided in Figure 12 is an example of the diurnal variation in the Station 4 temperature for the summer of 1993, showing data for all sensor depths. It also is emphasized that by using historical data for the upstream temperature, the primary impact of the ROS-related changes in river flow will be realized in the BFN hydrothermal model solely by the dilution of the plant waste heat in the diffuser mixing zone.

Upstream River Flow

A one-dimensional hydraulic model of Wheeler Reservoir provides computations of the time history of river flow and water surface elevation at BFN. The model implements a time-explicit predictor-corrector discretization originally applied to compressible flows (MacCormack, 1969). The MacCormack scheme is applied to the one-dimensional open channel continuity and dynamic equations,

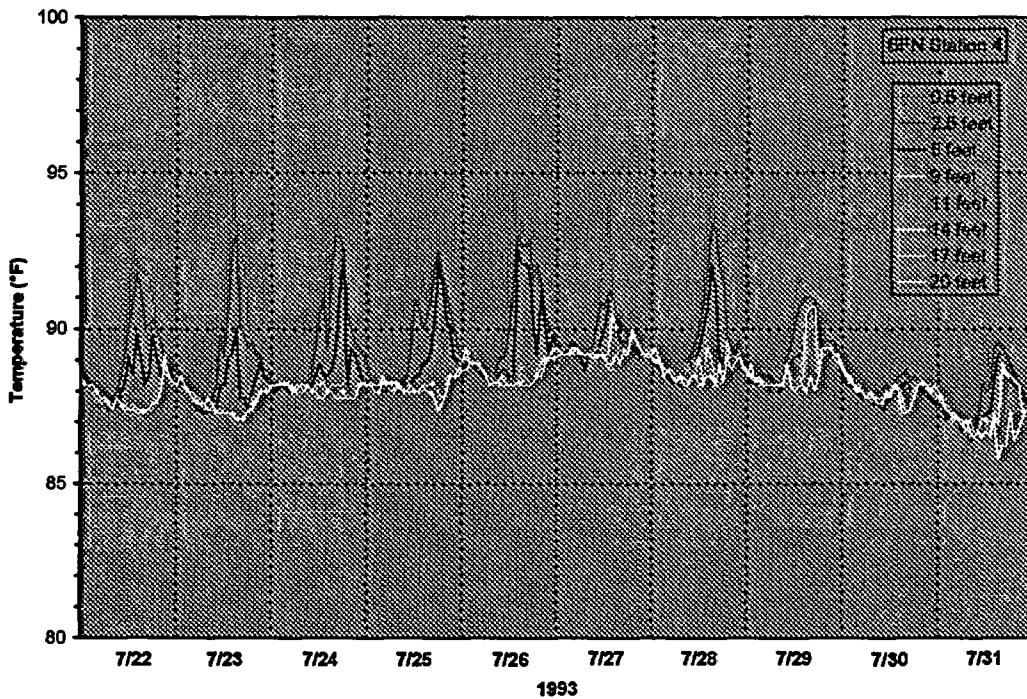

Figure 12. BFN Station 4 Temperature for Late July 1993

$$B \frac{\partial H}{\partial t} + \frac{\partial Q}{\partial x} = q, \text{ and} \quad (1)$$

$$\frac{\partial Q}{\partial t} + \frac{\partial}{\partial x} \left(\frac{Q^2}{A} \right) = -gA \left(\frac{\partial H}{\partial x} + S_f \right) + qV_x, \quad (2)$$

where

$H(x, t)$ = elevation of water surface relative to a datum,

$A(x, H)$ = wetted cross-sectional area,

$B(x, H)$ = width of channel at the water surface,

$Q(x, t)$ = volumetric flux (flowrate) through the cross section at x ,

$q(t)$ = local volume inflow per unit time per unit length of channel,

V_x = downstream (positive x) component of the local inflow velocity vector,

S_f = slope of the energy grade line,

g = acceleration due to gravity,

x = distance along channel, and

t = time.

The slope of the energy grade line is computed from the Manning equation by

$$S_f = \frac{Q|Q|n^2}{(1.486AR^{2/3})^2}, \quad (3)$$

where n is the roughness coefficient.

A significant feature of the MacCormack discretization scheme is the use of forward and backward differencing of the spatial derivatives in the predictor and corrector steps, respectively, to yield second-order spatial accuracy (Fletcher, 1991; Chaudry, 1987). The forward and backward differencing is switched between the predictor and corrector pseudo-steps from one real-time step to the next to promote numerical stability (Ferrick and Waldrop, 1977).

Eight 9.25-mile computational reaches make up the discretized domain for Wheeler Reservoir. The flow and water surface elevation time series from the computational node at Tennessee River Mile 293.5, approximately one-half mile downstream of the diffuser, are assumed to be representative of those at the plant intake and diffuser. The model employs a constant time step of 20 minutes; however, boundary condition data are supplied in the form of hourly inflow and water surface elevation time series at GUH and hourly outflow time series at WEH. The flows at the boundaries are assumed to remain constant between hourly readings.

When the model is used to provide flows for simulation of ambient and mixed temperatures at BFN, no local inflows to Wheeler Reservoir are specified. The absence of local inflow inputs to the model leads to a discrepancy in the computed water surface elevations along the reservoir, which is most significant at WEH. The discrepancy is corrected at midnight of each day by adding a constant value, equal to the discrepancy at WEH at midnight, to the water surface elevation at each node of the computational domain.

The basic statistical properties of the computed river flow obtained by the one-dimensional model are given in Table 3 for each summer of the simulation period. Shown in Figure 13 is an example of the running 24-hour average river flow for 1993. The difference between high weekday flows and low weekend flows is apparent. Shown in Figure 14 is an example of the computed hourly flow for a 10-day period in late July of the same year, emphasizing the diurnal variation due to peaking operations. Note that in the early morning hours, the model predicts hourly flows at BFN close to 20,000 cfs in the upstream direction. In all of these results it is emphasized that the releases from GUH and WEH, also provided in Figure 13 and Figure 14, correspond to values derived from the ROS operating policy.

Table 3. 24-Hour Average River Flow at BFN for June, July, and August

Year	Min (1000 cfs)	Avg (1000 cfs)	Max (1000 cfs)
1985	12.2	23.6	46.9
1986	6.9	17.0	29.8
1987	13.3	23.2	36.6
1988	12.7	20.2	32.4
1989	14.9	82.3	236.3
1990	14.0	26.8	44.6
1991	14.5	31.6	47.7
1992	13.9	33.1	60.0
1993	12.9	21.3	32.9
1994	15.6	41.1	67.6
1995	11.2	21.3	39.9
1996	13.4	32.2	53.7
1997	16.2	49.5	143.9
1998	12.8	35.3	101.6
1999	13.3	30.6	84.4
2000	9.5	21.8	33.1
2001	12.4	28.3	51.4
2002	10.9	20.2	31.6
2003	21.2	50.4	98.9
2004	14.1	35.4	82.8
1985-2004	6.9	32.3	236.3

Note: Estimated river flows based on the ROS operating policy.

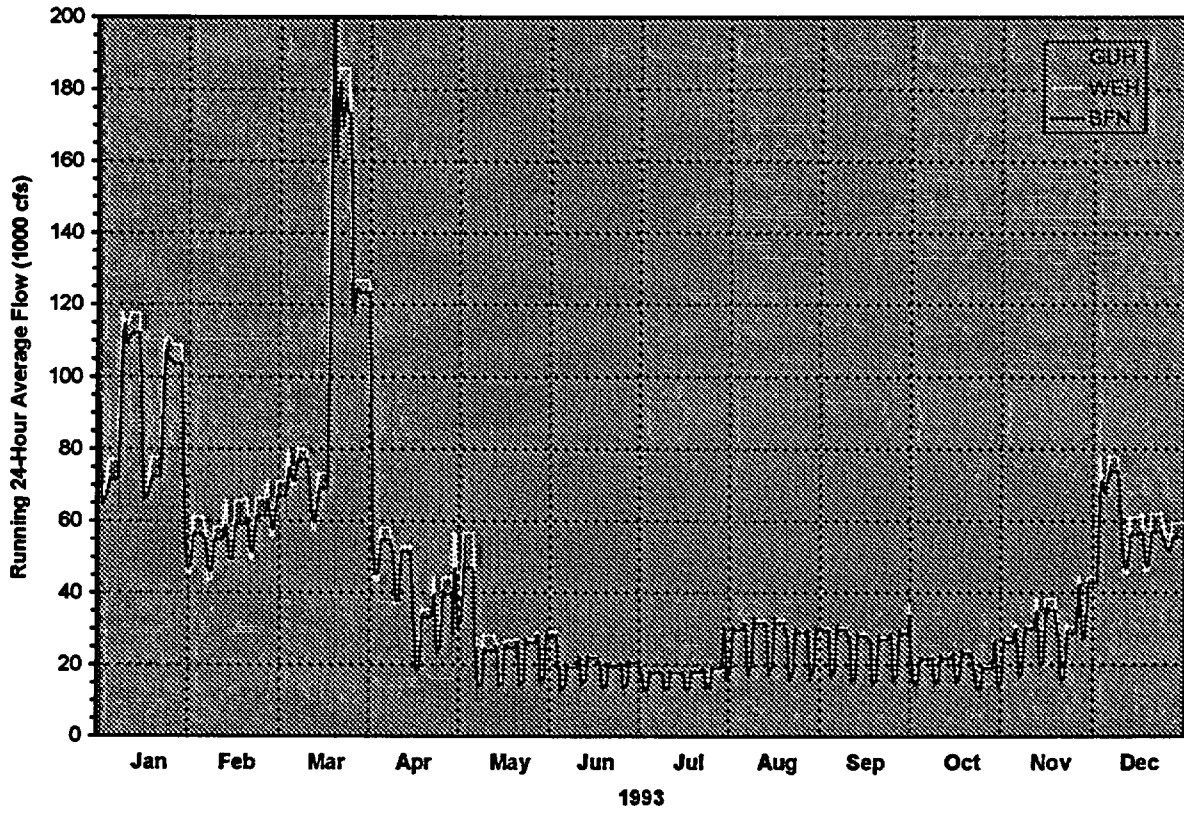

Figure 13. Computed Running 24-Hour Average River Flow at BFN for 1993

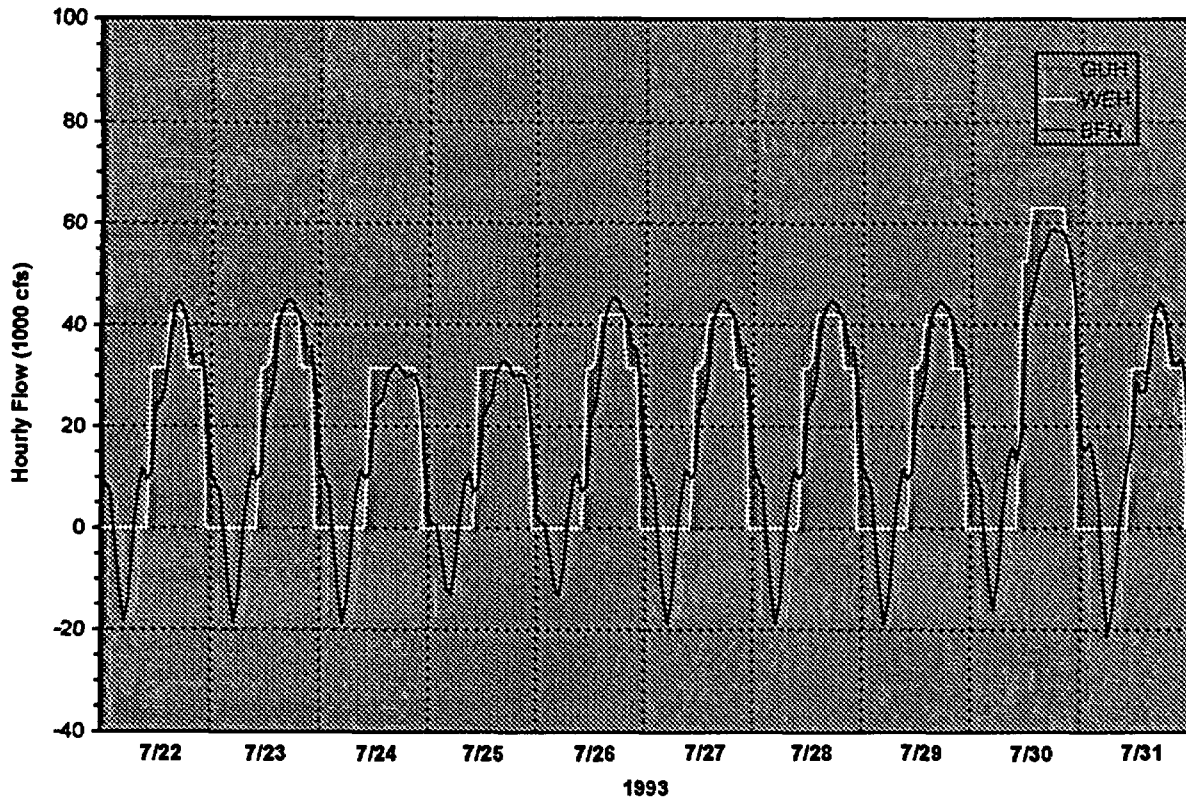

Figure 14. Computed Hourly River Flow at BFN for Late July 1993

Withdrawal Zone Module

The withdrawal zone for the BFN intake pumping station varies significantly depending on many factors. Perhaps most important is the ratio of the upstream river flow to the BFN intake flow, Q_R/Q_{BFN} . In the summer, when the daily volume of river flow is limited, peaking operations at GUH and WEH force the withdrawal zone to continually shift in the reservoir. Recent studies of flow patterns near BFN are given by Hopping and Smith (2002) and Lin and Hecker (2002). For high river flow, the BFN withdrawal zone resides primarily upstream of the plant and includes the right overbank (looking downstream) and portions of the main channel. For low river flow, the withdrawal zone can expand to encompass the entire river and include regions both upstream and downstream of the plant. The withdrawal from downstream can include recirculation of thermal effluent from the plant discharge diffusers.

Altogether, the transient behavior of the BFN mixing zone creates a significant source of uncertainty for the plant intake temperature. Again, this primarily is the case for low-flow periods in the summer when significant variations in temperature occur throughout the region of influence of the plant. TVA currently does not have a model that, with computational ease, effectively mimics all the complexities of the withdrawal zone to estimate the plant intake temperature. Under these conditions, in the present study, the BFN hydrothermal model incorporates a withdrawal zone module that simply assumes the intake temperature to be the same as the bottom river temperature upstream of the plant. In general, this assumption is considered fitting except perhaps during low-flow events, when Q_R/Q_{BFN} drops below 2 or 3 for an extended period of time. Recognizing this to occasionally be the case, sensitivity studies, discussed later in this report, were performed to examine the impact of elevated intake temperature during low-flow events.

Ambient Module

BFN water temperature Station 4 is located almost four miles upstream of the plant. Under these circumstances the question arises as to whether or not the temperature measurements from Station 4 provide a satisfactory estimate of the ambient conditions to be used for evaluating the dilution of the plant thermal effluent in the mixing zone. Actually, the same question also applies for the bottom temperature to be used for the plant intake.

It would seem at first glance that heating and mixing processes between Station 4 and the plant could significantly change the character of the water column. To determine to what extent this may be true, comparisons were made between the temperature measured at Station 4 and that measured at Station 1, which is located about 0.5 mile downstream of the plant (e.g., see Figure 7). This was accomplished by examining data for year 1986, when all of the BFN units were out of service, and thus not influencing the reservoir. A summary of the analysis is given in Table 4. Comparisons were made for temperatures at the compliance depth (5 feet) and near the river bottom. Both hourly and running 24-hour average data were examined. Plots of the running 24-hour average temperatures are given for the summer months in Figure 15. In all cases, the mean square difference between the Station 1 temperature and the Station 4 temperature was of magnitude 1°F or less. Average differences varied between 0.1°F and -0.4°F, all within the accuracy of the instream instrumentation ($\pm 0.5^\circ\text{F}$). Overall, these differences are considered inconsequential compared to the uncertainty of any procedure that would be used to try to correct for hydrothermal processes between Station 4 and ambient region in the immediate vicinity of the diffusers. Under these conditions, in the present study, the BFN hydrothermal model incorporates an ambient module for the mixing zone that assumes temperatures throughout the water column are the same as those at Station 4.

Table 4. Difference in Water Temperature between Station 1 and Station 4

Depth	Data	Root-Mean-Square Difference (°F)	Average Difference (°F)
5 feet	Hourly	1.1	-0.3
5 feet	Running 24-hr average	0.8	-0.4
Bottom	Hourly	0.9	0.1
Bottom	Running 24-hr average	0.6	0.0

- Notes: 1. Temperature differences computed as $T_{\text{Station 1}} - T_{\text{Station 4}}$.
 2. Bottom temperature for Station 4 includes floating sensor at depth 20 feet.
 3. Bottom temperature for Station 1 includes a fixed sensor at El. 535 feet, which varies from about 15 feet deep in the winter to about 20 feet deep in the summer.

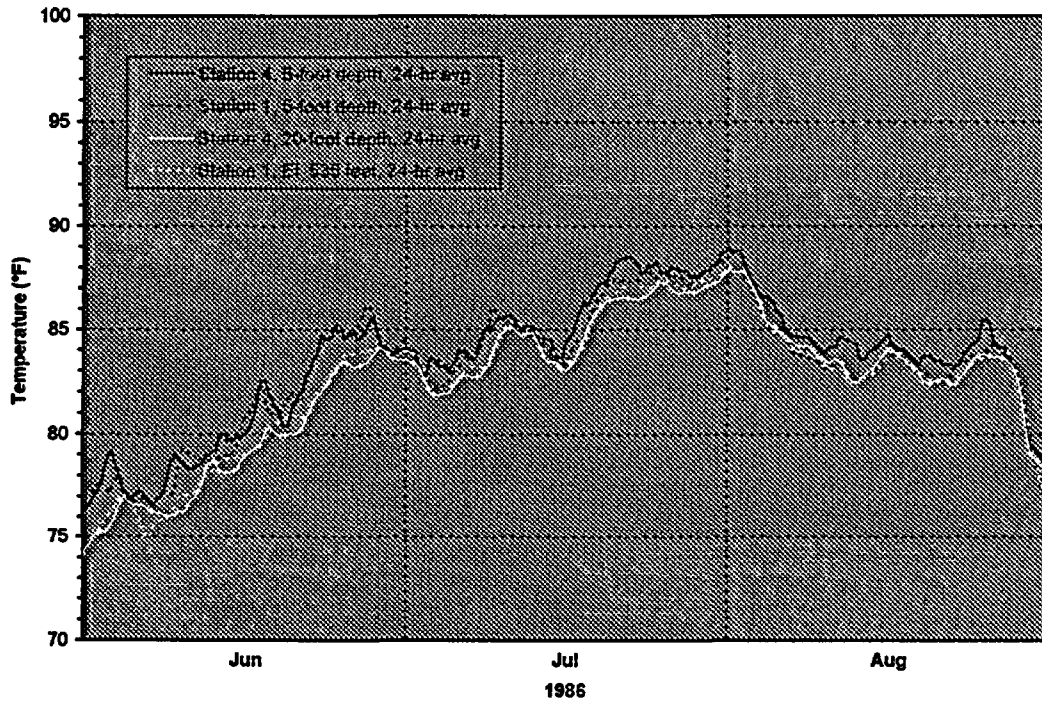

Figure 15. Station 1 and Station 4 Running 24-Hour Average Temperatures for Summer 1986

It needs to be reemphasized that the above choice is based on data in the absence of BFN operation (i.e., 1986). In a manner similar to that of recirculation at the plant intake, it is known that, at low river flows, spreading of the thermal effluent from the diffusers can propagate upstream and impact the local ambient. In general, since Station 4 is far upstream, heating of the ambient in such a manner is unnoticed in the temperature data for years when BFN is in operation (i.e., historically, the magnitude and duration of low-flow events have been too small for BFN impacts to “reach” Station 4). The buildup of a local, low-flow pool of thermal effluent can increase the temperature of the ambient water. This, in turn, can become re-entrained into the diffuser discharge and reduce the overall dilution of the plant waste heat. Recognizing that this can happen, sensitivity studies, discussed later in this report, were also performed to examine the potential impact of low-flow re-entrainment of the diffuser effluent.

Plant Performance Module

In the plant performance module a set of algorithms is used to compute the generation, turbine backpressure, and condenser discharge water temperature for each nuclear unit. The basic information needed for the algorithms is the unit reactor power level, unit CCW inlet temperature and flowrate, condenser cleanliness factor, and condenser physical characteristics, such as the number, length, diameter, material, and wall thickness of tubes. The generation for each unit is restricted to a maximum of 1280 MWe, due to limitations in the plant electrical system. The reactor power level is limited to a maximum of 120 percent of original design. In an iterative process, the turbine backpressure and generation are computed subject to the limits for the maximum reactor power level and a target value for the generator output. The target value for the generator output is the maximum unit generation, unless a unit derate is in effect, in which case the maximum value is reduced by the amount of the derate. Once the iterative process has converged to the unit generation, the condenser heat rejection and resulting condenser discharge water temperature are computed. The computed CCW temperature rise vs. unit generation for intake temperatures of 40°F and 90°F and CCW flowrates corresponding to open-mode and helper-mode operation are shown in Figure 16.

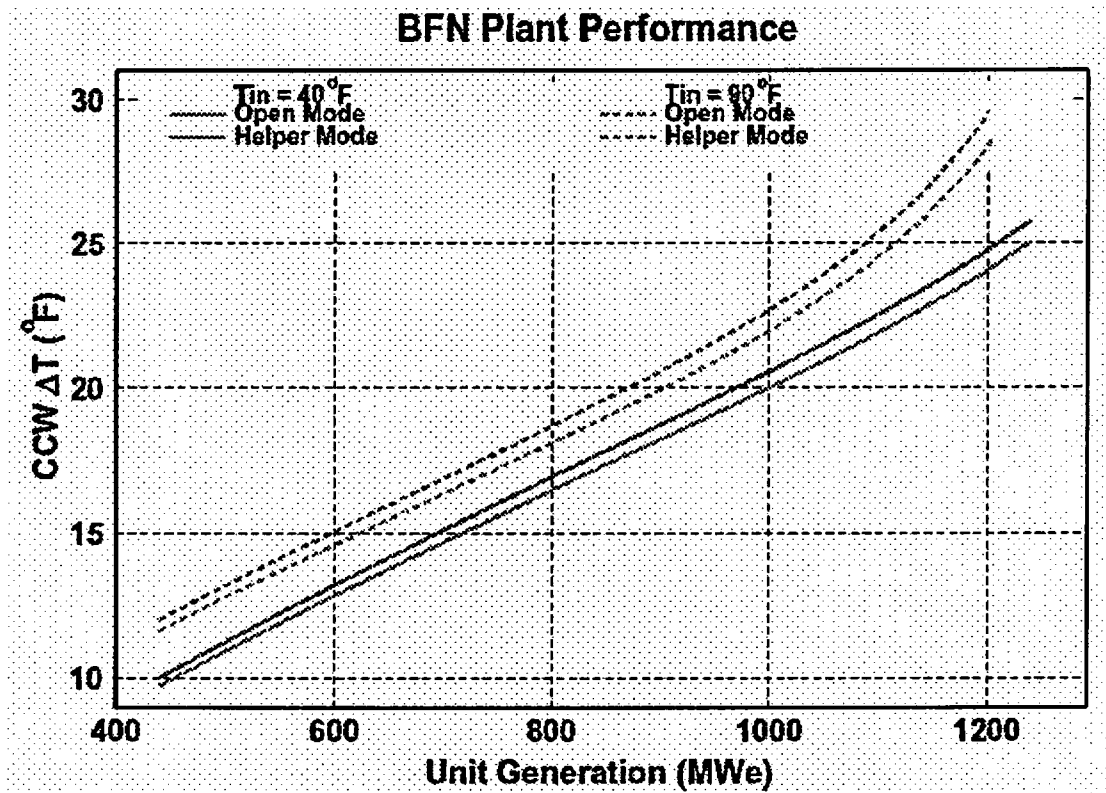

Figure 16. Temperature Rise across BFN Condensers

Cooling Tower Performance Module

The BFN cooling system originally included six mechanical draft cooling towers, constructed by Ecodyne Inc., each with 16 cells. The cooling towers are situated around a central warm water channel and are numbered clockwise 1 through 6, beginning with the tower nearest Gate Structure 1 (see Figure 6). Two of the original towers were destroyed by fire in separate events, Tower 4 in 1986 and Tower 3 in 1996. Tower 3 was reconstructed by Balcke-Durr Inc. in 1998. The TVA preferred alternative in the BFN FSEIS for operating license renewal (TVA, 2002) includes reconstruction of Tower 4 with 20 cells.

In the cooling tower performance module the tower discharge temperatures are computed using an algorithm described by Benton et al., 2002. Information required by the algorithm includes the tower design point and the actual wet-bulb temperature, water flowrate, total fan horsepower, tower intake (hot water) temperature, and tower capability. The design point for a mechanical draft cooling tower is defined by the water flowrate, wet-bulb temperature, range, approach, and total fan horsepower. The cooling tower range is the difference between design intake hot water temperature and the design discharge cold water temperature. The cooling tower approach is the difference between the design cold water discharge temperature and the design wet-bulb temperature.

Cooling tower capability is a measure of actual versus design tower performance, expressed as the percentage of the design water flowrate at which the tower can meet its design range with all other parameters at design point values. The capability is effectively a ratio of the percentage of heat the cooling tower removes from the water to the amount of heat the tower was designed to remove. It is determined by measuring the actual discharge flow and temperature from the tower at a known inlet flow and temperature condition and computing the heat removed from the water by the tower. This is compared to the heat that should have been removed if the tower performed according to design specifications. In the cooling tower computations, the actual cooling tower flowrate is divided by the capability to obtain an “adjusted” flowrate, which subsequently is used in the cooling tower performance algorithm. A tower that rejects less heat to the atmosphere than its design value has a capability of less than 100 percent. In such case the adjusted flowrate used in the computations is greater than the design value and the process yields an increased cooling tower discharge temperature.

The original towers at BFN (i.e., Towers 1, 2, 5, and 6) have never performed to design specifications. Formal tower performance tests were never conducted on these towers, and differences in physical condition and type of fill result in different capabilities for each tower. Based on limited operational data, these towers are estimated to have an average capability of about 80 percent. The new Tower 3 was designed with a higher cooling capacity than the original towers and performs closer to its design specifications than the older towers. Tower 3 is assumed to have a capability of about 96 percent, based on a formal acceptance test performed in August 1998 (Cooling Tower Test Associates, Inc., 1998). The proposed new Tower 4 is to be 25 percent larger than the existing towers, with 20 cells instead of 16. The design water flowrate and fan horsepower are also assumed to be 25 percent greater. The design wet-bulb temperature, range, and approach of the proposed new Tower 4 are assumed to be the same as that for the new Tower 3, as well as expected capability.

Due to structural degradation of the distribution channels and other components in the towers, the original cooling towers, first operated in 1975, can no longer operate at their design water flowrate (i.e., Towers 1, 2, 5, and 6). The maximum flowrate that currently can be routed through the original towers is estimated to be about 255,000 gallons per minute (gpm), or 92.7 percent of the design value. Based on limited field observations, it is estimated that Tower 3 currently is capable of passing a maximum flowrate of about 281,800 gpm, or 102.5 percent of the design value. It is assumed that if Tower 4 is rebuilt with 20 cells, it also will be operable at a maximum water flowrate of 102.5 percent of its design value, or 352,270 gpm. The design points, capabilities, and maximum water flowrates for the cooling towers are summarized in Table 5.

Cooling tower performance curves, computed based on the assumed capabilities of towers, are shown for the assumed maximum and design water flowrates in Figure 17.

Mixing Zone Module

The mixing zone module includes a mathematical model of effluent mixing from the three submerged multi-port diffusers. The model treats the effluent discharge from each diffuser as a fully mixed, plane buoyant jet with a two-dimensional (vertical and longitudinal) trajectory, shown schematically in Figure 18. The jet discharges into a temperature-stratified uniform-velocity channel flow and entrains ambient fluid as it evolves along its trajectory. The width, *b*, of the jet and the dilution of the effluent heat energy increase along the jet trajectory, decreasing the bulk mixed temperature along its path.

Table 5. BFN Cooling Tower Design Points and Operational Constraints

Tower No.		1, 2, 5, 6	3	4
Design Points	Wet-Bulb Temp. (°F)	78	80	80
	Water Flowrate (gpm)	275,000	275,000	343,750
	Total Fan Horsepower	3200	3200	4000
	Approach (°F)	17.0	10.0	10.0
	Range (°F)	31.7	23.7	23.7
	Cells	16	16	20
Operational Constraints	Capability (%)	80 (estimated avg)	96 (measured)	96 (assumed)
	Maximum Water Flowrate (gpm)	255,000	281,800	352,270

Towers 1,2,5,6 - Capability 80%

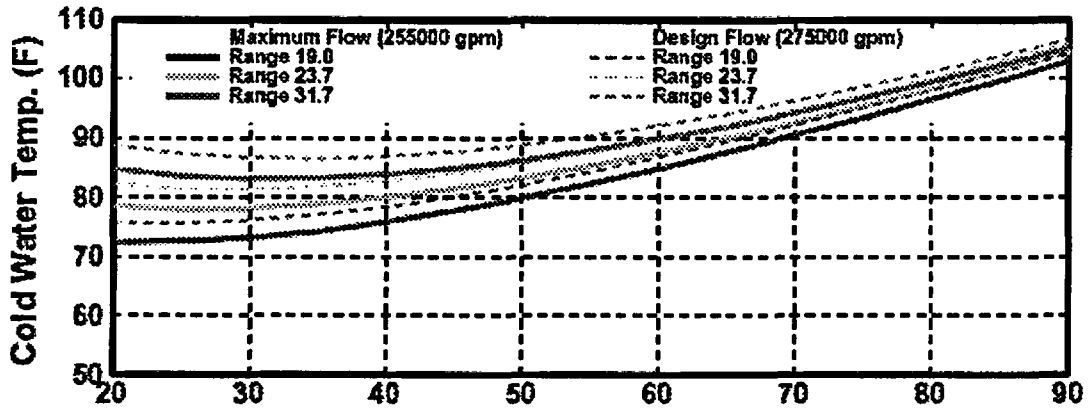

Tower 3 - Capability 96%

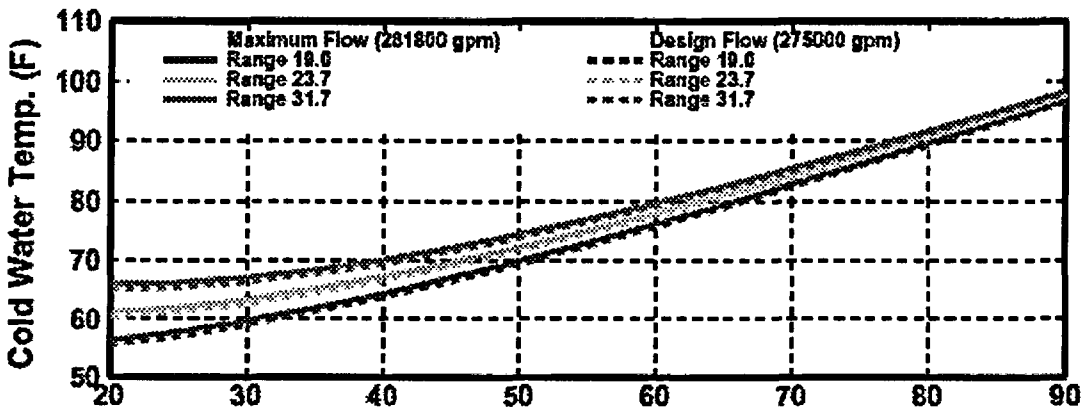

Tower 4 (proposed) - Capability 96%

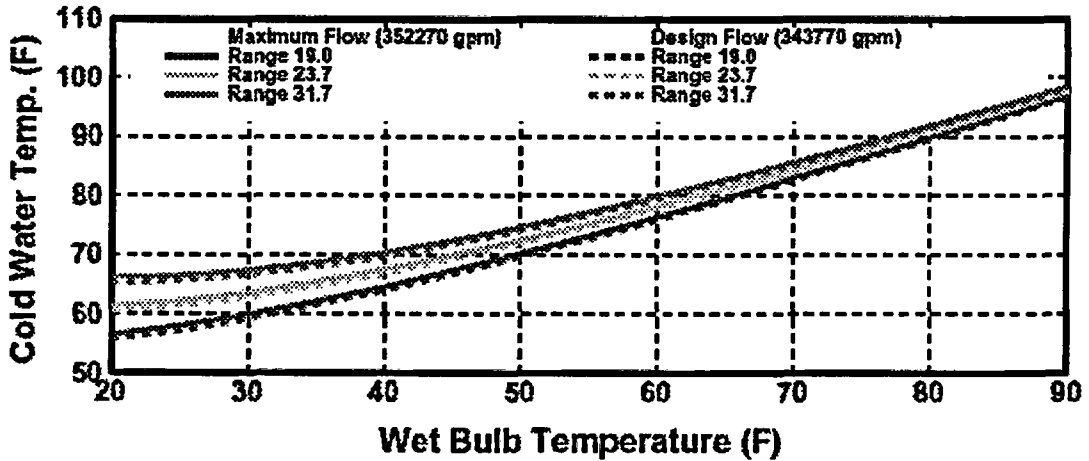

Figure 17. BFN Cooling Tower Performance Curves

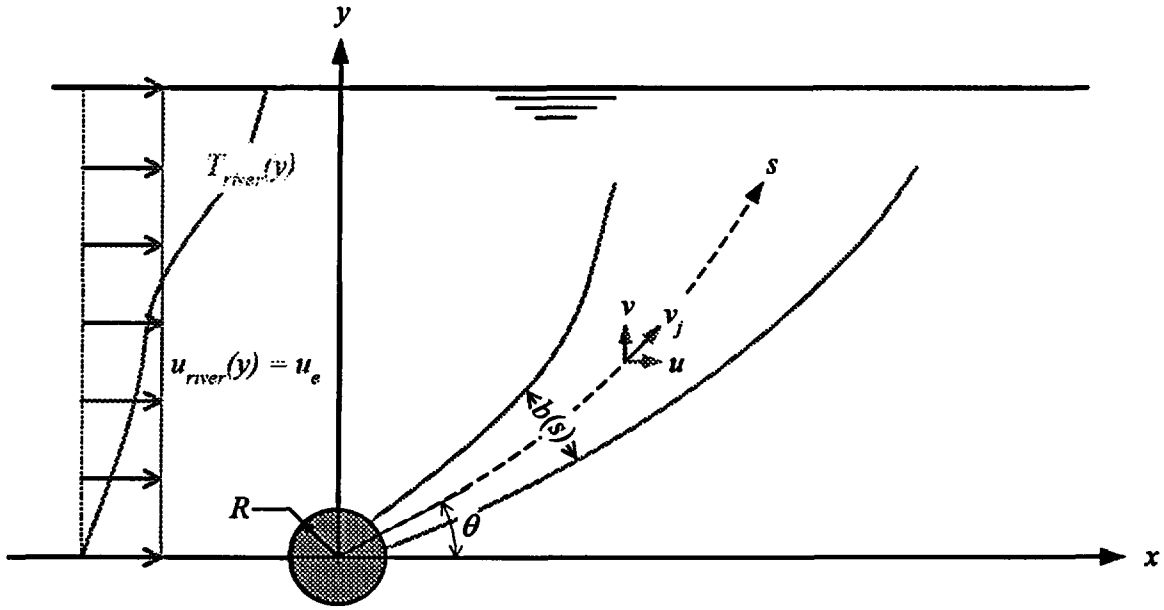

Figure 18. Two-Dimensional Plane Buoyant Jet Model for a Submerged Diffuser

Consideration of the mass, momentum, and energy conservation for a jet cross section orthogonal to the jet trajectory and having a differential thickness, ds , yields a system of ordinary differential equations (Benton, 2003):

$$\frac{d}{ds}(\rho_j v_j b) = m_e, \quad (4)$$

$$\frac{d}{ds}(\rho_j v_j b u) = m_e u_e, \quad (5)$$

$$\frac{d}{ds}(\rho_j v_j b v) = m_e v_e + b g (\rho_e - \rho_j), \quad (6)$$

$$\frac{d}{ds}(\rho_j v_j b c T_j) = m_e c T_e, \quad (7)$$

$$\frac{dx}{ds} = \frac{u}{v_j}, \text{ and} \quad (8)$$

$$\frac{dy}{ds} = \frac{v}{v_j}, \quad (9)$$

with the auxiliary equations:

$$m_e = \alpha \rho_e [(u_e - u)^2 + v^2]^{1/2}, \quad (10)$$

$$\rho_j = \rho_{\text{water}}(T_j), \quad (11)$$

$$\rho_e = \rho_{\text{water}}(T_e), \quad (12)$$

$$v_j = (u^2 + v^2)^{1/2}, \quad (13)$$

$$T_e = T_{\text{river}}(y), \quad (14)$$

$$u_e = u_{\text{river}}, \text{ and} \quad (15)$$

$$v_e = 0. \quad (16)$$

In the foregoing equations, the subscripts j and e denote conditions within the buoyant *jet* and conditions within the ambient fluid that is *entrained* by the jet, respectively. Thus, ρ_j denotes the density of water at a point inside the jet and ρ_e denotes the density of water entrained from the ambient water body. The magnitude of the velocity along the jet trajectory is denoted by v_j , with x- and y-components u and v , respectively. The individual jets issuing from the array of 2-inch outlet ports of each diffuser (e.g., recall Figure 4) are modeled as a plane jet issuing from a slot of width b_0 in the circumference of the pipe. Ideally, the slot width is chosen to preserve the total momentum flux issuing from the circular ports of the diffuser. In the present work, the slot width is one of the parameters used to calibrate the model to match water temperature measurements from the instream monitoring stations at the edge of the regulatory mixing zone (i.e., Stations 1, 16, and 17, see Figure 7).

The model does not consider explicitly the transverse gradients of velocity, temperature, and density that exist within the jet due to turbulent diffusion of the effluent momentum and energy. These effects are modeled as an entrainment mass flux, m_e , induced by the vectorial difference between the velocity of the jet and that of the ambient river flow. Empirical relationships for the entrainment coefficient α are based on arguments of jet self-similarity and asymptotic behavior. These relationships incorporate non-dimensional parameters, such as a Richardson or densimetric Froude number, that describe the relative strengths of buoyancy and momentum flux in the jet (see, for example, Fischer et al., 1979; McIntosh et al., 1983). In the present work, the entrainment coefficient, like the slot width, is adjusted to produce a calibrated model. Comparisons with temperature measurements corresponding to multiple diffuser operation also suggest that the entrainment coefficient varies primarily with the number of adjacent diffusers in operation.

This system of differential equations, auxiliary equations, and boundary conditions:

$$b|_{s=s_0} = b_0, \quad (17)$$

$$x|_{s=s_0} = R \cos \theta, \quad (18)$$

$$y|_{s=s_0} = R \sin \theta, \quad (19)$$

$$u|_{s=s_0} = \frac{q_0}{b_0} \cos \theta, \quad (20)$$

$$v|_{s=s_0} = \frac{q_0}{b_0} \sin \theta, \text{ and} \quad (21)$$

$$T_j|_{s=s_0} = T_0 \quad (22)$$

comprise a first-order, initial-value problem that can be integrated from the diffuser slot outlet ($s = s_0$) to any point along the plume trajectory. Note in the above that R is the radius of the diffuser conduit, b_0 is the “effective” width of the diffuser slot, θ is the exit angle of the diffuser jet, T_0 is the temperature of effluent issuing from the slot, and q_0 is the effluent discharge per unit length of diffuser. In practice, integration of the governing equations is halted when the jet centerline reaches a point five feet below the water surface (the regulatory compliance depth) or when the upper boundary of the jet reaches the water surface. The jet temperature, T_j , at this point is reported as the fully-mixed temperature to which the thermal regulatory criteria are applied or to which monitoring station data at the edge of the regulatory mixing zone are compared. The integration is done with an adaptive step-size, fourth-order Runge-Kutta algorithm.

Other Model Features

The following additional features are noted concerning the time step, CCW hydraulics, atmospheric heat exchange, and dynamic behavior of the hydrothermal model.

Time Step

As discussed previously, the frequency of measurements used to monitor compliance with the plant NPDES limits is 15 minutes. However, the hydrothermal model uses a time step of one hour, corresponding to that of the hydrologic and meteorological data. Thus, in the model, the limit for the downstream 1-hour running average temperature was applied to each hourly computation, and the NPDES limits encompassing a 24-hour running average were applied to

values computed based on a running average of twenty-four consecutive hourly values. On a 24-hour average basis, the difference between modeling twenty-four 1-hour numbers vs. ninety-six 15-minute numbers is expected to be negligible. On an hourly basis, however, the hydrologic and meteorological data, which were collected as instantaneous measurements, may contain spikes that otherwise would be attenuated by averaging four 15-minute values. This, in turn, could lead the model to overestimate the impact of the plant on the downstream 1-hour running average river temperature limit.

CCW Hydraulics

The BFN hydrothermal model does not compute the detailed hydraulic aspects of the plant CCW system. For example, energy and hydraulic grade lines are not determined for the intake pumping station, plant inlet and discharge conduits, condensers, cooling towers, cooling tower warm and cold water channels, and diffusers. Such computations would allow the characteristics of these components to be explicitly represented in the model. The primary impact of such would be to more closely simulate the hour-by-hour variation of flowrates and heat fluxes among the various components of the CCW system. At this time, adding these details is not expected to improve the confidence of the hydrothermal model, at least with the amount of information currently at hand. In general, operation of the plant CCW system is usually very steady, except perhaps during special events, such as in changing from open-mode to helper-mode. In addition, on a 24-hour average basis, small hour-by-hour variations in the distribution of flow and heat in the CCW system are not expected to have a significant impact on the computed NPDES compliance temperatures. Also, the uncertainty surrounding estimates of the characteristics of certain components of the CCW system, needed to determine detailed hydraulic aspects, is likely just as high as that surrounding the method of flow routing presently used in the hydrothermal model. This method distributes the CCW flow among the diffusers and cooling towers based on simple rules derived from design values, formal operating procedures, and observations, and is summarized later in discussions related to the model baseline assumptions.

Atmospheric Heat Exchange

The BFN hydrothermal model does not explicitly consider the impact of atmospheric heat exchange for the cooling tower channels (when in helper-mode) and the diffuser mixing zone. The heated effluent in the channels and mixing zone resides at temperatures warmer than natural conditions. In this manner, heat in the channels and mixing zone will escape to the atmosphere via evaporation. However, the time-scale associated with this process is much longer than that associated with cooling from entrainment and mixing of ambient river water in the direct vicinity of the diffusers. As such, there is no need to include atmospheric heat exchange in the model. In part, the impact of atmospheric heat exchange already is implicitly represented by the fact that this process, if significant, is included in the measurements for downstream river temperature that are used to calibrate the hydrothermal model.

Dynamic Behavior

The BFN hydrothermal model is “quasi-unsteady” in predicting the dynamic behavior of the river and plant. That is, the various components of the model are formulated based on steady behavior, and then linked together to simulate an overall unsteady process. In this manner the model neglects detailed transient behaviors and assumes the plant and river shift hour-by-hour from one steady-state condition to the next. In general, most transients caused by changes in river and plant conditions occur at time-scales wherein the perturbations in flow and temperature are “calmed” within one hour. However, there exists unsteady events at larger time-scales that are not represented in the “baseline” model assumptions. Two notable concerns are river low-flow events and major shifts in plant operation. As previously discussed, the model does not include the buildup and flushing of a pool of warm effluent in the immediate vicinity of the plant during river low flow events, which can impact both the plant withdrawal zone and mixing zone. For cooling tower operation, due to: (1) the time to start equipment, (2) the time for the flow to traverse through the cooling tower field, and (3) the time for the effluent to propagate through the mixing zone, the impact of changing units from open-mode to helper-mode will not necessarily be revealed at the NPDES monitoring locations within one hour. The same is potentially true of the process of implementing plant derates. Overall, when the plant is operating near an NPDES limit, such events can cause the model results to stray from what likely would occur in practice.

The sensitivity simulations, discussed later, were designed to address these and other significant sources of uncertainty that accompany the model formulation.

Diffuser Model Calibration

The mixing zone module for the diffuser effluent was calibrated using historical data. Of primary importance in the calibration are measurements of the downstream temperature from Stations 1, 16, and 17. Of these stations, Stations 16 and 17 were not deployed until 1988. At that time, BFN was idle due to a regulatory outage of all three units that began in 1985. Unit 2 returned to service in 1991 and Unit 3 in 1996. Unit 1 is yet idle. Thus, since 1988, when the current arrangement for NPDES monitoring initiated data collection, there exists periods of one-unit operation (i.e., from 1991 to 1996), periods of two-unit operation (from 1996 to 2004), but no periods of three-unit operation. Since the operation of the diffusers is linked directly to the number of units in service, this means that post-1988 data for a good calibration of the mixing zone module exists for diffuser operation containing one and two active legs, but not three. Data for a good calibration is considered to be that with the active diffusers fully and equally loaded (e.g., each operating unit at full power and in open-mode).

In reality, post-1988 data also exists for diffuser operation with three active legs. This occurs during periods of cooling tower operation, when the flow in the cold water return channel is free to enter the diffuser of any unit that is idle or in helper-mode (e.g., recall that all the gates in Gate Structure 1 are usually kept open for all units for all modes of operation). For example, under the current conditions with Unit 2 and Unit 3 in service, the operation of the Unit 1 diffuser is essentially idle. If cooling tower operation occurs with one unit in helper-mode, the open-mode diffuser will be discharging the full flow and heat of one unit, while the remaining two diffusers, receiving flow from the cold water return channel, will carry only about 50 percent of the flow and a substantially reduced amount of heat. Thus, the flow and heat discharging from the three diffusers is highly unbalanced, which is not consistent with conditions considered adequate to obtain a good calibration of the mixing zone module.

Data needed for the calibration runs includes measured releases from GUH and WEH, measured water elevation at WEH, measured upstream temperature profiles, measured meteorology, and measured BFN generation. Since detailed records of cooling tower operation are not routinely maintained, the periods and type of cooling tower operation (e.g., one or two units in helper-mode) were estimated based on water temperature measurements of the plant discharge entering the diffusers, which are readily available. The algorithms for determining required cooling tower usage and load reductions were disabled in the model in order to simulate, as closely as possible, the actual operation of the plant. The effective diffuser slot width (b_0) and entrainment coefficients (α) for 1, 2, and 3 active diffuser legs were adjusted to achieve a close match with the measured downstream temperatures (i.e., from Stations 1, 16, and 17). It was found that better agreement with measured data was achieved if the entrainment coefficient is made to vary with the number of diffuser legs in service. For a single active diffuser, the “best” value for the

entrainment coefficient was found to be 1.0, while for two active diffusers, the “best” value was 0.25. In general, a smaller entrainment coefficient is anticipated for multiple diffuser operation because of “interference” among the diffusers in drawing ambient flow into the effluent jets. An entrainment coefficient of 0.25 also was selected for three active diffusers; however, this was based on a relatively small sample size of periods with three-leg operation. This is because, as emphasized above, three diffusers are active only during periods containing cooling tower operation, which occurs only for the warmer periods of the warmer summers. The “best” agreement with measured downstream temperatures was achieved with an effective slot width of 1.5 feet for all conditions (i.e., one, two, or three active diffusers).

Two years of data, 1993 and 1994, were selected for calibration of the diffuser module with one diffuser leg in service (i.e., only Unit 2 was in service during these years). Four years of data, 1999, 2001, 2002, and 2004, were selected for calibration with two diffuser legs in service (i.e., both Units 2 and 3 were in service during these years). The plant experienced summertime cooling tower operation in all of these years, thus, as mentioned above, providing brief periods with three diffuser legs in service. The calibration work sought to determine values for the entrainment coefficient and effective slot width that yield the best agreement with measurements during the summer months of the year, June through August, when cooling tower operation and unit derates are most likely to occur. For each of the calibration years, summertime comparisons of the measured 24-hour average downstream temperatures and those computed using the mixing zone module are shown in Figure 19 through Figure 24. Recall that the mixing zone module explicitly incorporates the impact of stratification via a two-dimensional buoyant jet model (e.g., see Figure 18). This version of the mixing zone module is referred to as the “stratified” diffuser model. Also shown in Figure 19 through Figure 24 are results based on a version of the mixing zone module that does not incorporate the impact of stratification (e.g., see TVA, 1972 and Stolzenbach, 1975). This version of the mixing zone module is referred to as the “unstratified” diffuser model. In general, during periods of relatively pronounced stratification of the upstream ambient, the stratified diffuser model tends to match the measured downstream temperatures more closely than does the unstratified model. Areas of disagreement during cooling tower operation, in particular during days 206 to 218 in Figure 23, primarily are due to uncertainty as to exactly how the cooling towers were historically operated. The RMS and average errors for the 24-hour average downstream temperatures computed by the stratified model are shown in Table 6 for all months of the year and in Table 7 for the more crucial summer months.

BFN - One Unit - Estimated Actual Operation

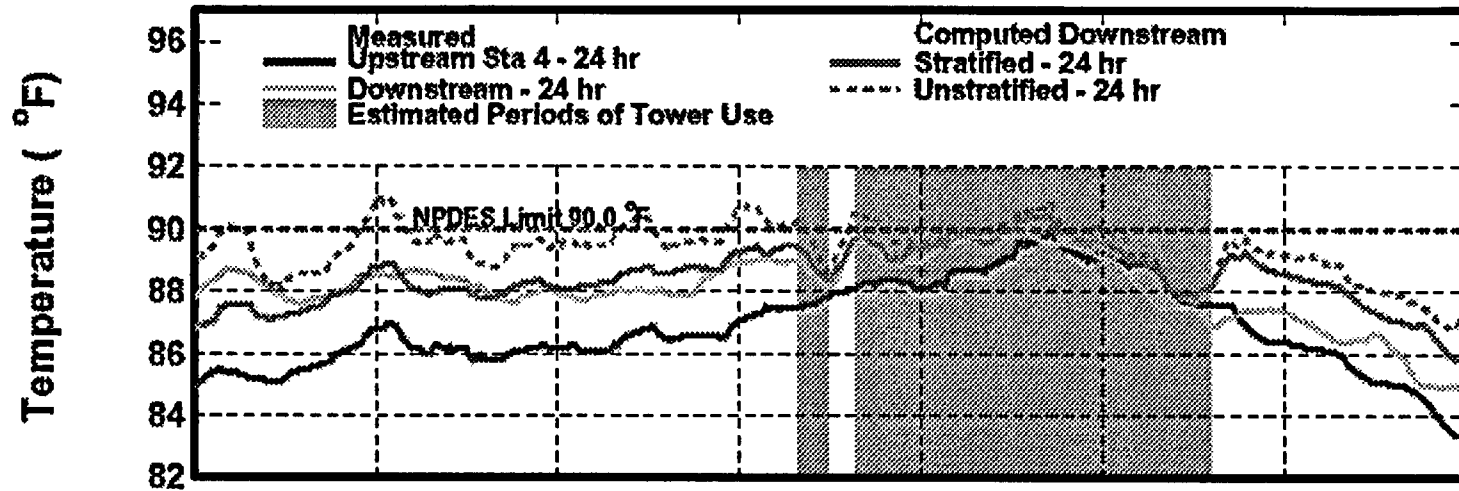

Upstream Stratification (5 ft - bottom)

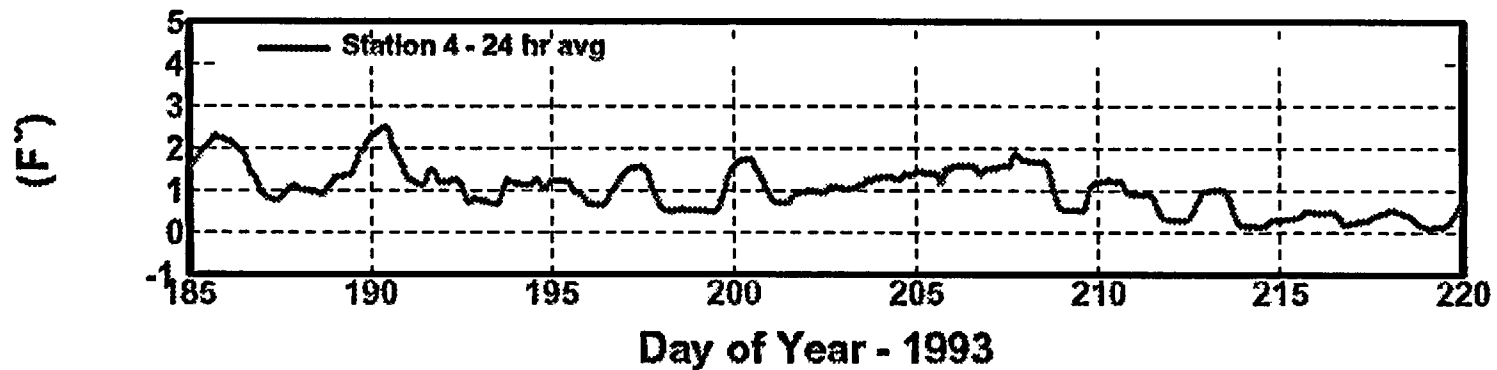
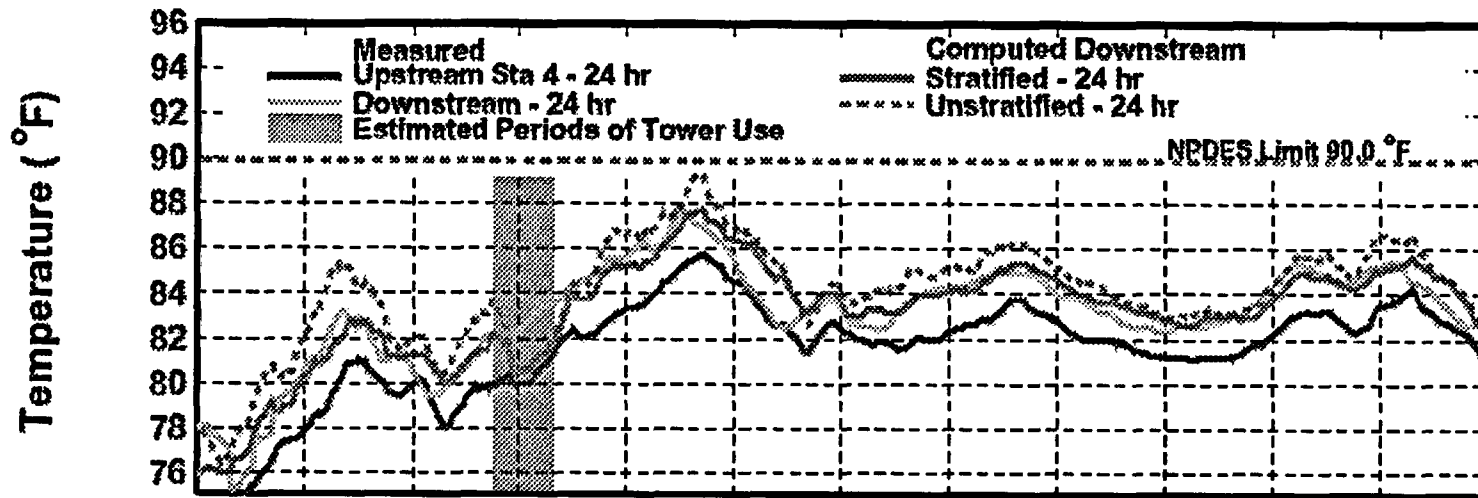

Figure 19. Computed vs. Measured Temperatures for One-Unit Operation for Summer 1993

BFN - One Unit - Estimated Actual Operation



Upstream Stratification (5 ft - bottom)

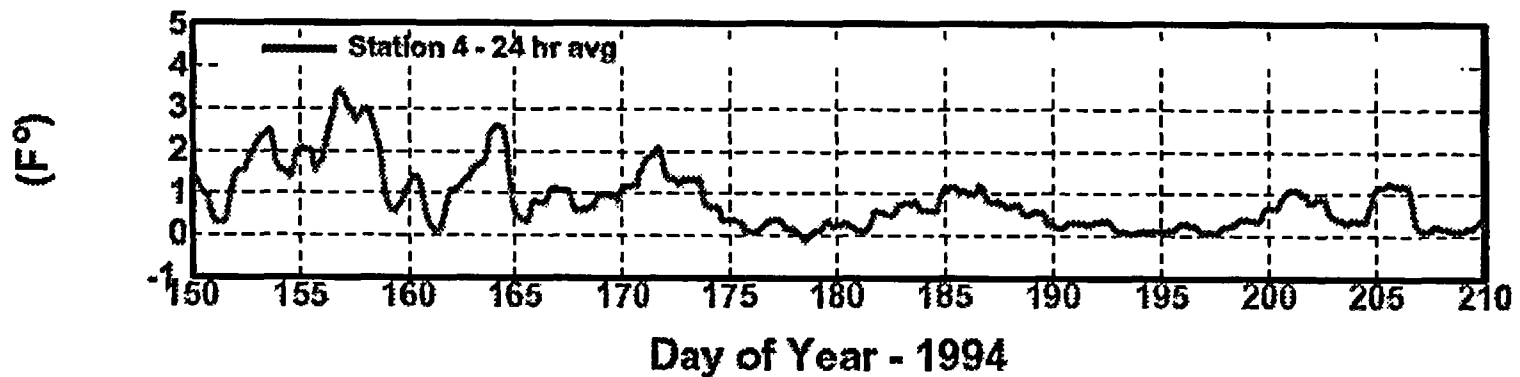
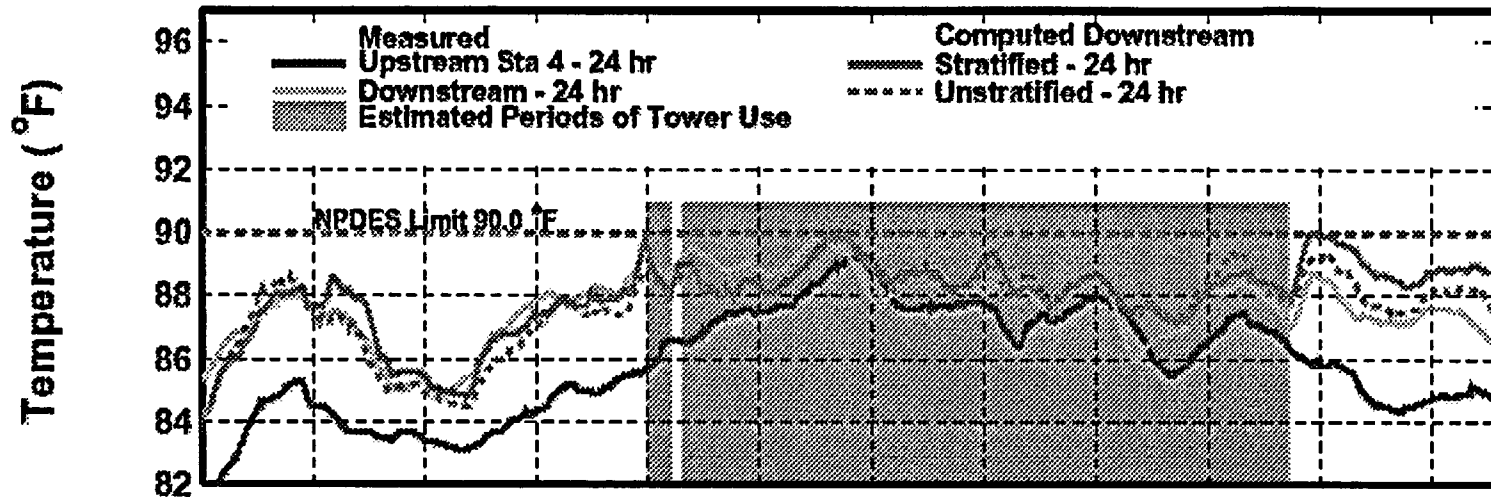

Figure 20. Computed vs. Measured Temperatures for One-Unit Operation for Summer 1994

BFN - Two Units - Estimated Actual Operation



Upstream Stratification (5 ft - bottom)

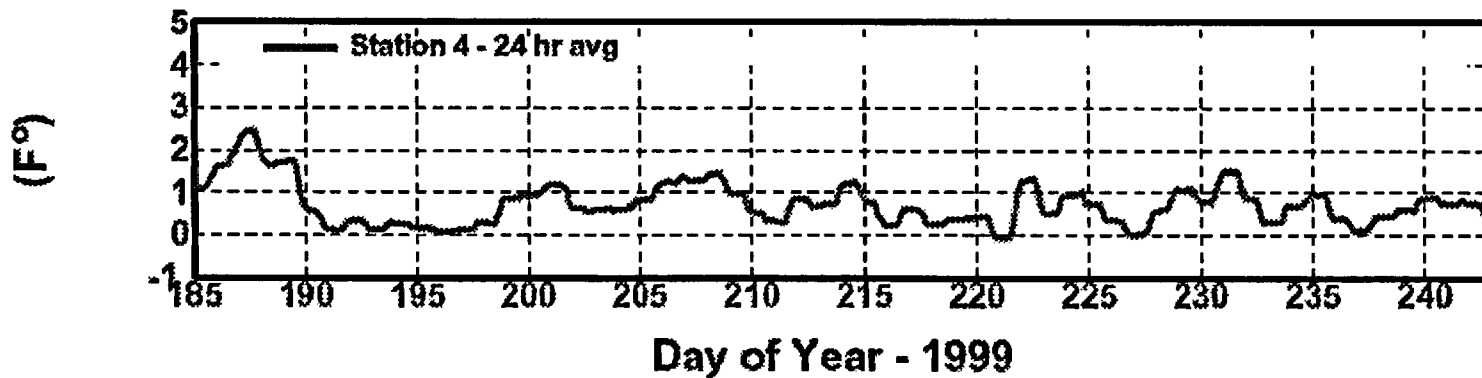
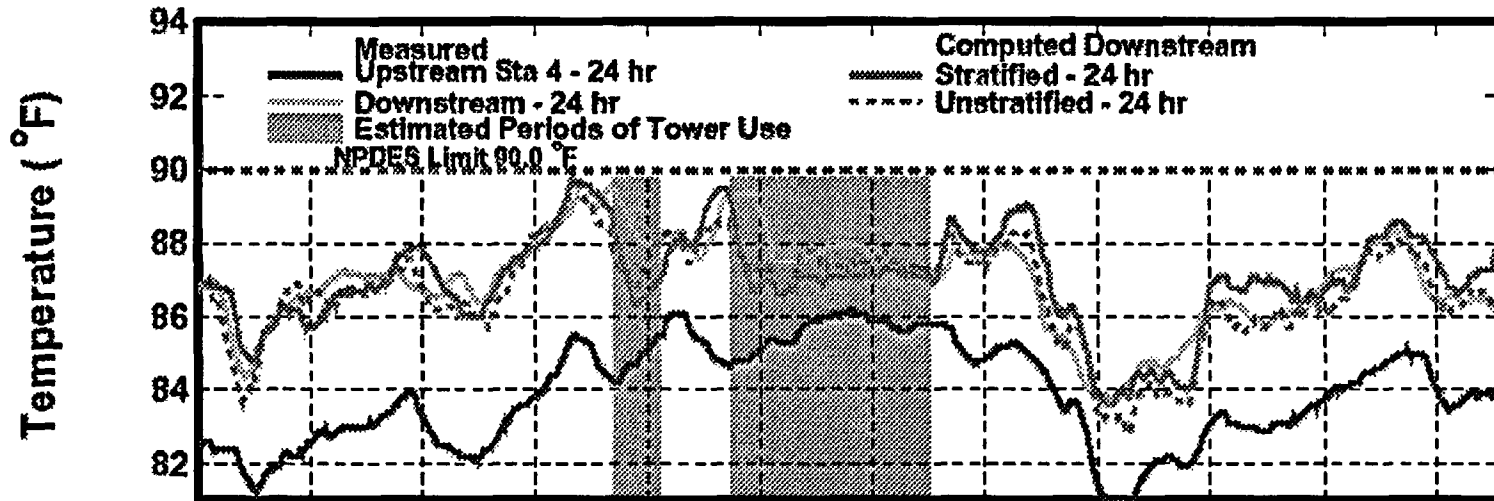

Figure 21. Computed vs. Measured Temperatures for Two-Unit Operation for Summer 1999

BFN - Two Units - Estimated Actual Operation



Upstream Stratification (5 ft - bottom)

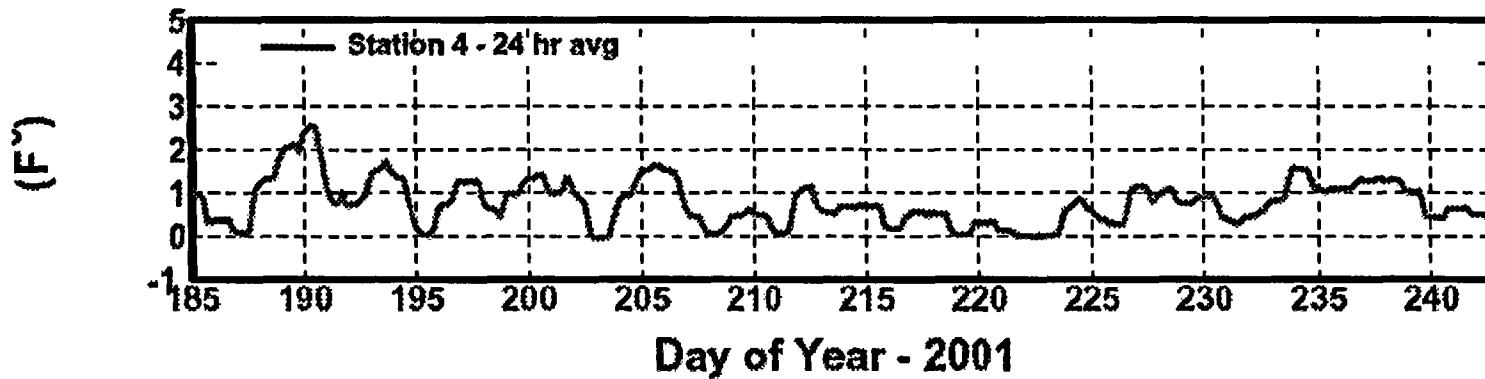
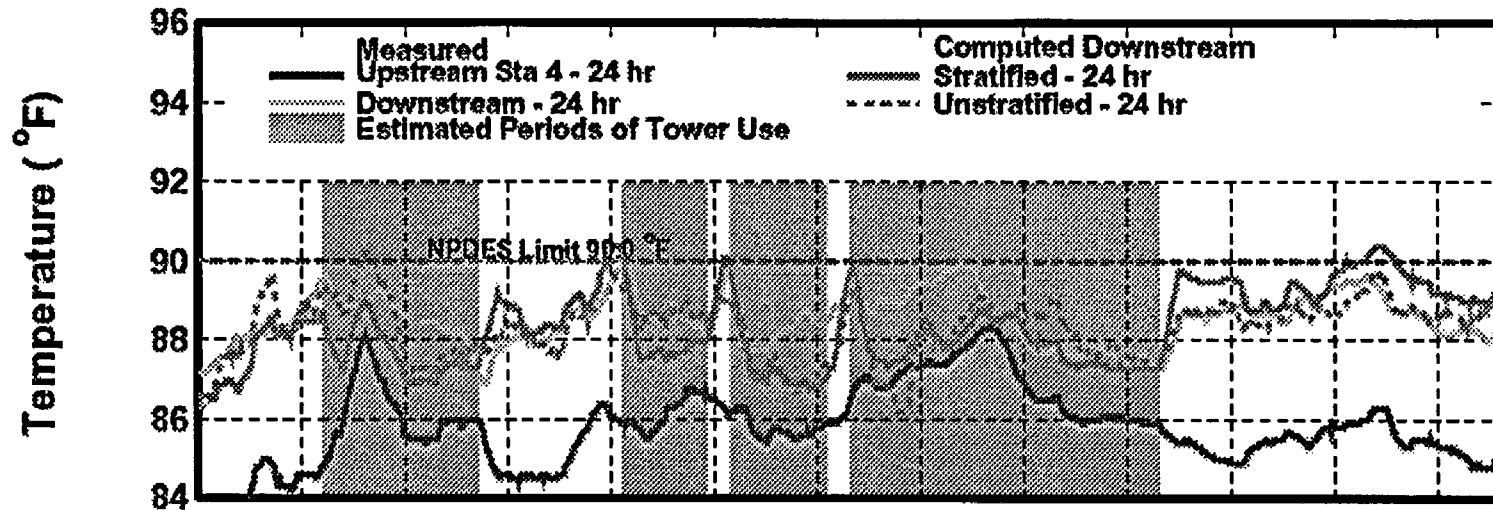

Figure 22. Computed vs. Measured Temperatures for Two-Unit Operation for Summer 2001

BFN - Two Units - Estimated Actual Operation



Upstream Stratification (5 ft - bottom)

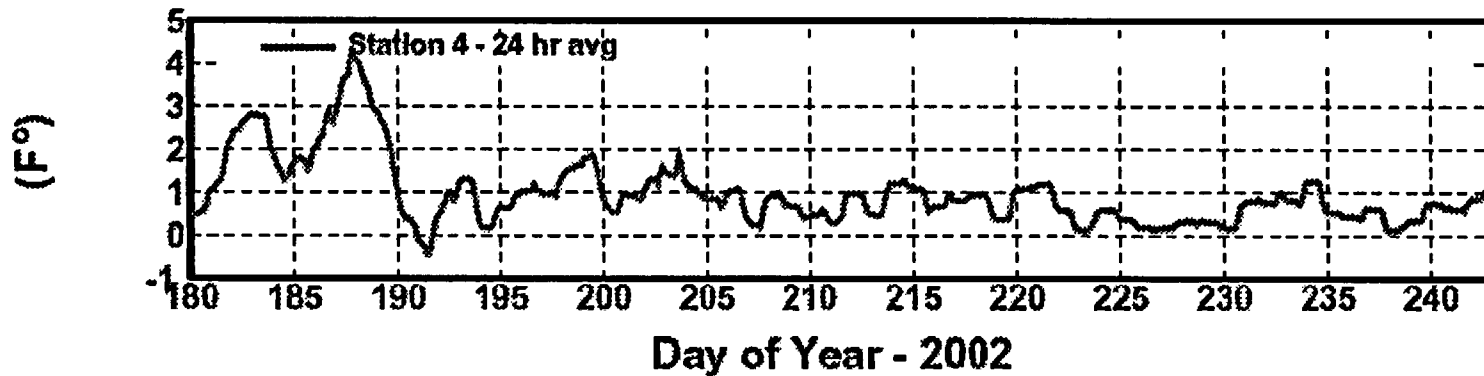
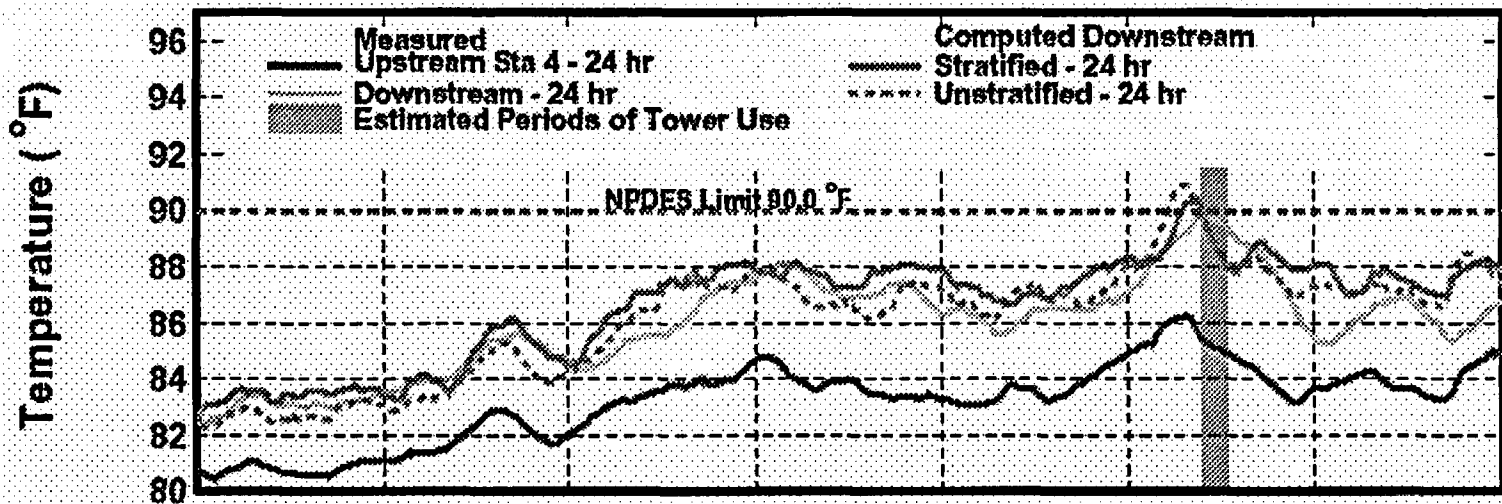

Figure 23. Computed vs. Measured Temperatures for Two-Unit Operation for Summer 2002

BFN - Two Units - Estimated Actual Operation



Upstream Stratification (5 ft - bottom)

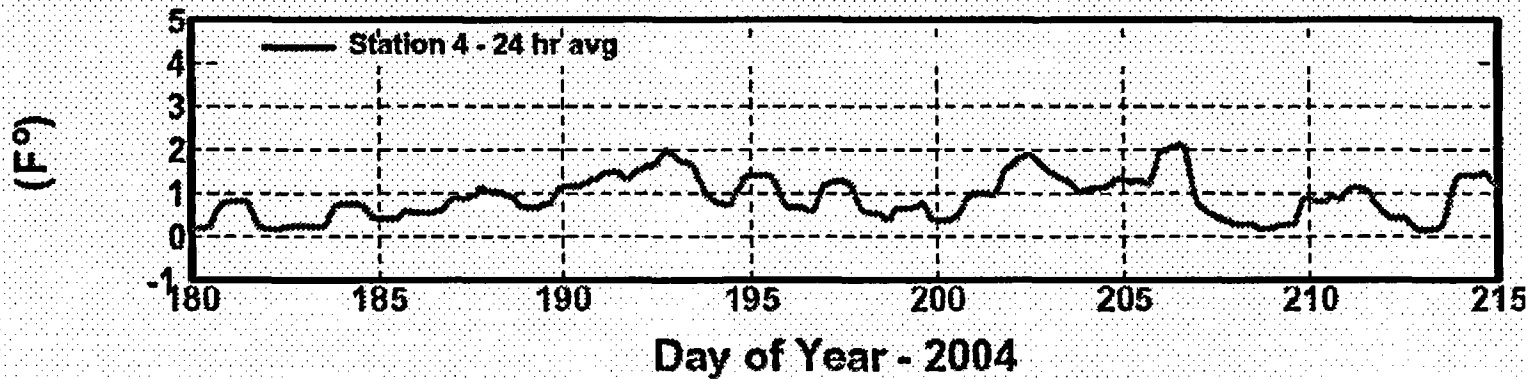

Figure 24. Computed vs. Measured Temperatures for Two-Unit Operation for Summer 2004

Table 6. RMS and Average Temperature Errors for January through December

Year	Active Legs	RMS Error*	Average Error*	Sample Size	Entrainment Coefficient			Slot Width		
					Active Legs			Active Legs		
					1	2	3	1	2	3
1993	1	1.46	0.93	8504	1.0	0.25	0.25	1.5	1.5	1.5
1993	3	0.50	0.39	255	1.0	0.25	0.25	1.5	1.5	1.5
1994	1	1.51	0.77	8691	1.0	0.25	0.25	1.5	1.5	1.5
1994	3	1.65	-1.41	68	1.0	0.25	0.25	1.5	1.5	1.5
1999	2	1.22	0.27	8084	1.0	0.25	0.25	1.5	1.5	1.5
1999	3	0.59	0.12	675	1.0	0.25	0.25	1.5	1.5	1.5
2001	2	1.13	0.08	8497	1.0	0.25	0.25	1.5	1.5	1.5
2001	3	1.10	-0.91	262	1.0	0.25	0.25	1.5	1.5	1.5
2002	2	1.32	0.13	8009	1.0	0.25	0.25	1.5	1.5	1.5
2002	3	1.03	-0.80	750	1.0	0.25	0.25	1.5	1.5	1.5
2004	2	1.43	0.04	5144	1.0	0.25	0.25	1.5	1.5	1.5
2004	3	0.87	-0.72	16	1.0	0.25	0.25	1.5	1.5	1.5

* RMS and average errors based on running 24-hour average downstream temperature using stratified diffuser model

Table 7. RMS and Average Temperature Errors for June, July, and August

Year	Active Legs	RMS Error*	Average Error*	Sample Size	Entrainment Coefficient			Slot Width		
					Active Legs			Active Legs		
					1	2	3	1	2	3
1993	1	0.78	0.29	1953	1.0	0.25	0.25	1.5	1.5	1.5
1993	3	0.50	0.39	255	1.0	0.25	0.25	1.5	1.5	1.5
1994	1	0.64	0.10	2140	1.0	0.25	0.25	1.5	1.5	1.5
1994	3	1.65	-1.41	68	1.0	0.25	0.25	1.5	1.5	1.5
1999	2	0.90	-0.03	1533	1.0	0.25	0.25	1.5	1.5	1.5
1999	3	0.59	0.12	675	1.0	0.25	0.25	1.5	1.5	1.5
2001	2	0.67	0.06	1946	1.0	0.25	0.25	1.5	1.5	1.5
2001	3	1.10	-0.91	262	1.0	0.25	0.25	1.5	1.5	1.5
2002	2	0.80	-0.10	1458	1.0	0.25	0.25	1.5	1.5	1.5
2002	3	1.03	-0.80	750	1.0	0.25	0.25	1.5	1.5	1.5
2004	2	0.86	0.62	1497	1.0	0.25	0.25	1.5	1.5	1.5
2004	3	0.87	-0.72	16	1.0	0.25	0.25	1.5	1.5	1.5

* RMS and average errors based on running 24-hour average downstream temperature using stratified diffuser model

MODEL SIMULATIONS

Simulations with BFN hydrothermal model were performed for a total of twelve different cases. This includes a simulation with a baseline set of assumptions, Case 0, and eleven sensitivity runs, Cases 1 through 11, representing other probable conditions of the plant and river. The sensitivity runs were chosen based on the recognized uncertainty of many of the basic assumptions. In the subsequent sections, the baseline assumptions and Case 0 results are presented first. This is followed by discussions as to the changes in assumptions for the sensitivity runs and the results for Cases 1 through 11.

Baseline Assumptions

The basic assumptions defining the baseline conditions for Case 0 are summarized in Table 8. A brief discussion of the major groupings of assumptions follows.

Condenser Cooling Water Operation

It is assumed that three CCW pumps are in operation on each unit at all times, regardless of unit generation and cooling mode. For open-mode operation, a unit's CCW flow is routed directly to its corresponding diffuser leg. The flowrate per unit for open-mode operation with three CCW pumps is 691,200 gpm (1540 cfs). In helper-mode operation, the CCW flow is routed to the cooling tower warm water channel, from which it is withdrawn by the cooling tower lift pumps and subsequently directed to one or more diffusers by Gate Structure 1. Due to increased resistance when routed to the cooling towers, the CCW flowrate for helper-mode is reduced to approximately 671,930 gpm (1497 cfs). During a unit shutdown, the CCW pumps are assumed to remain in service, providing cool water for the additional dilution of the diffuser effluent for any units that are yet generating power.

Table 8. Baseline Assumptions for BFN Hydrothermal Modeling (Case 0)

No.	Description
<i>Unit Operation</i>	
1	All three units are operating at 120% extended power uprate with a maximum generation of 1280 Mwe per unit.
2	Unit generation is not reduced until all towers are brought into service, subject to the 80% minimum tower water loading.
3	Unit generation is reduced (derated) when operation at full load will cause a regulatory temperature parameter to exceed its regulatory limit (i.e., maximum downstream temperature or maximum temperature rise).
4	Generation is reduced sequentially between the operating units.
5	Generation is reduced in increments of 50MW. (This for modeling "trial-and-error" solution only.)
6	If generation is reduced on a unit it must remain at the lowest value for at least 1 hour before starting to recover.
7	If generation on a unit drops below 440MW it is shut down.
<i>CCW Operation</i>	
8	Open-mode CCW flows are 289260, 529810, 691200 gpm for 1, 2, and 3 pumps, respectively.
9	The static head on the CCW pumps is increased by 2.63 feet if the unit is operating in helper-mode.
10	Helper-mode CCW flows are 284980, 519370, 671930 gpm for 1, 2, and 3 pumps, respectively.
11	Always operate with 3 CCW pumps.
12	CCW pumps are only throttled when a scenario specifically calls for this operation.
13	The condenser cleanliness is 85% for all units.
14	Backpressure is limited to 5.5 in. Hg.
<i>Cooling Tower Operation</i>	
15	The plant contains 6 cooling towers. Tower 1 is a 16-cell Ecodyne tower, Tower 2 is a 16-cell Ecodyne tower, Tower 3 is a 16-cell Balcke-Durr tower, Tower 4 is a 20-cell Balcke-Durr tower, Tower 5 is a 16-cell Ecodyne tower, and Tower 6 is a 16-cell Ecodyne tower. All cooling tower equipment is assumed to be in reliable operating condition.
16	Towers are brought into service in order of decreasing rating (best first to worst last).
17	Tower rating is a combination of maximum flow, the design point, and the capability.
18	The tower with the largest flow capacity is not necessarily brought into service first.
19	Towers are brought into service one lift pump at a time until all of the CCW flow is handled or all towers are in service.
20	The last lift pump added can be throttled to 80% flow.
21	Only the last lift pump on a tower may be throttled in order to not exceed the maximum flow for that tower.
22	All but the last tower added will be operated at their individual maximum water loading.
23	If towers are brought into service they must remain in service for at least 8 hours.
24	Towers are brought into service if the 24-hour average mixed downstream temperature approaches 1 degree of the limit.
25	Towers are brought into service if the 24-hour average mixed temperature rise approaches 2 degrees of the limit.
26	All Ecodyne 16 cell towers have the following design points - inlet wet bulb temperature = 78°F; hot water temperature = 126.7°F, cold water temperature = 95°F, water flowrate = 275000 gpm.
27	All Balcke-Durr 16 cell towers have the following design points - inlet wet bulb temperature = 80°F; hot water temperature = 113.7°F, cold water temperature = 90°F, water flowrate = 275000 gpm.
28	All Balcke-Durr 20 cell towers have the following design points - inlet wet bulb temperature = 80°F; hot water temperature = 113.7°F, cold water temperature = 90°F, water flowrate = 343750 gpm.
29	All Ecodyne towers have a capability of 80%.
30	All Balcke-Durr towers have a capability of 96%.
31	All 16-cell Ecodyne towers contain one fan per cell, two lift pumps, and a total flow capacity of 255000 gpm.
32	All 16-cell Balcke-Durr towers contain one fan per cell, two lift pumps, and a total flow capacity of 281800 gpm.
33	All 20-cell Balcke-Durr towers contain one fan per cell, two lift pumps, and a total flow capacity of 352250 gpm.

Table 8 Continued. Baseline Assumptions for BFN Hydrothermal Modeling (Case 0)

No.	Description
<i>Equipment Service Loads</i>	
34	The service load for the CCW pumps is 1.35 MW/pump.
35	The service load is the same for a CCW pump whether it's throttled or not.
36	The service load for the cooling tower lift pumps for the 16-cell towers is 2.39 MW/pump.
37	The service load for the cooling tower lift pumps for the 20-cell tower is 2.99 MW/pump.
38	The service load is the same for a tower lift pump whether it's throttled or not.
39	The service load for the cooling tower fans is 200 hp/fan.
<i>Plant Water Routing</i>	
40	If a unit is operating in open-mode the water flows from the condenser directly to the diffuser.
41	All of the water from all units operating in helper-mode is fully mixed at the entrance to the cooling tower warm water channel.
42	The mixed water from all units operating in helper-mode is lifted to the towers.
43	All of the water leaving the towers is mixed and then split evenly among the diffusers of units not operating in open-mode. That is, water from the towers is not mixed with water discharged from any unit operating in open-mode.
44	Any water from units operating in helper-mode and not flowing through the towers is bypassed to the diffusers.
45	Bypass water is mixed with tower discharge.
<i>Diffuser Mixing</i>	
46	Equivalent diffuser slot width of 1.5 feet with entrainment coefficients of 1.00 for one-unit operation and 0.25 for two-unit and three-unit operation.
47	No re-entrainment of diffuser effluent.
48	No recirculation of diffuser effluent.
<i>Ambient River Conditions</i>	
49	River flows from preferred alternative for River Operations Study approved by TVA board on May 19, 2004.
50	River temperatures from historical data from BFN Station 4 instream water temperature monitor.

Plant Water Routing

All condenser cooling water for a unit operating in open-mode flows from the condenser, through Gate 1A, and into the corresponding diffuser for that unit. If a unit is in full helper-mode, Gate 1A is closed, and the CCW flow is diverted into the cooling tower warm water channel. Flow diverted to the cooling tower warm water channel from all units operating in helper-mode is assumed to be fully mixed as it enters the channel. As such, all operating cooling towers are assumed to have the same warm water temperature. If possible, a sufficient number of cooling tower lift pumps are operated to achieve a balance between water flowing into the warm water channel and water lifted from the channel into the towers. Each tower may have a different discharge flowrate and temperature, depending on the towers individual pump flowrates and cooling capacities. Water is discharged from all operating cooling towers into the tower cold water return channel and is considered to be fully mixed when it reaches the Gate Structure 1. All gates in Gate Structure 1 are assumed to be fully open at all times, consistent with normal operating practice. All flow in the cold water return channel is assumed to be split evenly among the diffusers of units not operating in open-mode. That is, water from the cooling towers is assumed not to mix with water discharged from any unit operating on open-mode.

The baseline conditions for cooling towers includes four of the original Ecodyne 16-cell cooling towers (Towers 1, 2, 5, and 6), one existing Balcke-Durr 16-cell cooling tower (Tower 3), and a new yet to be constructed 20-cell cooling tower (Tower 4) of type similar to the Balcke-Durr tower. This arrangement was identified as the TVA preferred alternative in the BFN FSEIS of 2002. For this arrangement, and others described later in this report, the capacity of the cooling tower lift pumps is not sufficient to handle all of the flow delivered by the CCW pumps (i.e., assuming three, non-throttled CCW pumps are operated per unit). For example, the CCW flowrate for three units in helper-mode is estimated at about 4490 cfs. However, if all the cooling towers of the TVA preferred alternative are in service, the pumping capacity of the cooling towers is estimated only at about 3685 cfs. Thus, the CCW flow from the units is about 805 cfs more than the capacity of the cooling tower lift pumps. To handle this situation, if the amount of CCW flow from the units in helper-mode exceeds the combined capacity of the operating tower lift pumps, the hydrothermal model assumes Gate 1A will remain partially open for the last unit placed in helper-mode, bypassing the amount of water in excess of the cooling tower pumping capacity directly to the unit's diffuser. This bypass water is mixed with the water in the cooling tower cold water return channel entering the diffuser via Gate Structure 1. Thus, the temperature of the diffuser discharge for the last unit placed in helper-mode will be higher than that for any other units earlier placed in helper-mode.

Cooling Tower Operation

All units are assumed to be operated in open-mode until one or more instream temperature limits is approached. At each hour of a simulation, the following steps are taken:

1. The computation of instream temperatures is performed, using discharge temperatures computed with the current levels of tower usage and unit generation.
2. If all instream temperature parameters are below their action levels, no further action is taken and computations proceed to Step 1 for the next hour.
3. If any instream temperature parameter is above its action level, any idle cooling towers are brought into service by the following process:
 - Gate Structure 1A is closed for as many units as is necessary to maintain proper water level in the tower intake basin.
 - Units are placed in helper-mode in reverse numerical order (i.e., Unit 3 first, Unit 2 next, and Unit 1 last). A unit is defined to be in helper-mode when its Gate 1A is closed, thereby diverting its CCW flow into the cooling tower warm water channel.

- The order in which cooling tower lift pumps (CTLPs) are added is based on which of the idle towers will provide the greatest amount of cooling.
 - All operating CTLPs are run at their maximum capacity with the exception of the last CTLP brought into service, which may be throttled to 80 percent of its design flow, to balance inflow and outflow from the cooling tower warm water channel.
 - Any bypass flow that is required for Gate 1A is performed for the last unit placed in helper-mode.
 - As CTLPs are added, the Gate 1A bypass is recomputed until the bypass flow is less than the minimum flowrate for the next available CTL pump.
4. Steps 1 through 3 are repeated, increasing the number of CTLPs until either all instream temperature parameters are below their action levels, or all CTLPs are in service.
 5. If all CTLPs are in service and one or more instream parameters still exceed an action levels, but none exceed its NPDES limit, no further action is required and computations proceed to Step 1 for the next hour.
 6. If all CTLPs are in service and one or more of the instream temperatures exceed its NPDES limit, the unit derate process is initiated, as described below for Unit Operation.
 7. Once a CTLP has been placed in service, it must remain in service for a minimum of eight hours. This limitation is imposed to prevent cycling on and off of lift pumps over unrealistically short intervals.
 8. After the minimum operating period for a lift pump has passed, the pump is removed from service and the computation of instream temperatures is performed (Step 1), using discharge temperatures computed with the decreased tower usage.

Unit Operation

All units are assumed to operate at full power unless a derate is in effect. The unit derate process is initiated only when an NPDES instream limit or unit turbine backpressure limit can not be met solely by the use of cooling towers. When one or more units must be derated, the following steps are taken:

1. Unit generation is reduced according to one of the following two schemes:
 - **Sequential (baseline run)**—Generation is reduced by 50 MWe on the last unit placed in helper-mode which, for these simulations, is the lowest numbered operating unit (Unit 1). This ensures that the derate is taken on the unit with the smallest portion of CCW flow diverted to the cooling towers, thus maximizing the reduction in discharge temperature.
 - **Uniform (one of the sensitivity runs)**—Generation is reduced by 50 MWe on all operating units (e.g., 150 MWe total if three units are in service).

Note that these reduction schemes are solely for the purpose of the hydrothermal model to iterate to an operating condition that satisfies all of the NPDES and backpressure limits. They do not represent actual operating procedures for the plant.

2. The computation of the NPDES instream temperatures is repeated, using diffuser discharge temperatures computed with the decreased generation (Cooling Tower Operation, Step 1).
3. Steps 1 and 2 are repeated, increasing the derate(s) until either all instream temperature parameters and turbine backpressures are below their limits, or one or more units reaches the minimum continuous generation level of 440 MWe.
4. If a unit reaches the minimum continuous generation level and one or more NPDES instream temperature or turbine backpressure limits is yet exceeded, the unit is removed from service. Although generation of the unit is terminated, the CCW pumps remain in service. In this case, by opening Gate 1A, the CCW flow from the unit is diverted from the cooling tower warm water channel back to its diffuser, and a sufficient number of CTLPs are removed from service to maintain a flow balance in the warm water channel. The computation of the NPDES instream temperatures is repeated, using diffuser discharge temperatures computed with the decreased generation (Cooling Tower Operation, Step 1).
5. When a unit is derated, a period of one hour must pass before any attempt is made to restore the unit to full power. If the unit is removed from service, it is restarted at the minimum continuous generation level of 440 MWe. If the unit load is 440 MWe or more, its generation is increased at a rate of three percent of full power/per hour until either full power is achieved or the generation again causes a violation of an NPDES instream temperature limit or a turbine backpressure limit. The unit may be returned to helper-mode, if necessary, any time after it is restarted.

Equipment Service Loads

Equipment service loads represent the power requirements needed to operate the basic, large-scale mechanical equipment of the cooling system—the CCW pumps, the cooling tower lift pumps, and the cooling tower fans. In a rigorous analysis of plant service load, variations in power due to changes in operation of the CCW pumps would be included. In the present study, since three CCW pumps are assumed to operate fully for each unit at all times, whether or not the unit is generating thermal power, the service load for the CCW pumps is not included in tracking the overall balance of plant power requirements. Under these conditions, plant energy losses due to changes in the CCW system include the service load for only two components—the cooling tower lift pumps and the cooling tower fans. Note that due to the different capacities, the pump service load differs for a 16-cell tower vs. a 20-cell tower. Also note that the variation in service load due to throttling is neglected for the cooling tower lift pumps.

Diffuser Mixing

Baseline values for the diffuser slot width and entrainment coefficient are those that provide good agreement with the mixing indicated by the NPDES monitoring system data from ambient and downstream stations. Because of several simplifying assumptions of the diffuser jet model, the baseline values that produce agreement are outside the range of values that would be physically realistic. The diffuser jet slot width of 1.5 feet used in the present work is much greater than the value of 0.28 foot that would preserve the initial momentum flux of a diffuser operating in open-mode at the design flowrate of 1540 cubic feet per second. The entrainment coefficient values of 1.0 for single-unit operation and 0.25 for multiple-unit operation are much greater than the range of 0.1667 ± 0.0084 quoted by Fischer et al. (1979) for asymptotic solutions of slot plumes.

The slot width and the entrainment coefficient should be viewed as calibration parameters that account for mixing mechanisms that are not modeled explicitly. These mechanisms include the zone of establishment of the slot jet, the three-dimensional nature of the jet entrainment (including lateral entrainment), the variation of the entrainment coefficient with local conditions along the jet trajectory, re-entrainment of mixed effluent into the jet, and recirculation of mixed effluent into the plant intake. The sensitivity of the diffuser model to re-entrainment and recirculation is examined in the latter sections of this report.

Ambient River Conditions

For the baseline case, river flows upstream of the plant are based on releases from GUH and WEH corresponding to the new reservoir operating policy from the ROS. Upstream river temperatures correspond to the historical measurements from BFN Station 4.

Baseline Results

Key results for the baseline simulation, Case 0, are summarized in Table 9 and Figure 25. The following observations are made.

- Cooling tower operation occurs in 19 of the 20 years of simulation. In these years, the annual hours of cooling tower operation varied between 9 (1994) and 793 (1993). The corresponding magnitude of annual energy loss due to cooling tower operation varies between 100 MWh (1994) and 31,500 MWh (1993).
- For the entire 20-year period of simulation, the average annual hours of cooling tower operation is 322, with an annual average energy loss of 11,700 MWh.
- Unit derates occur in 4 of the 20 years of simulation – 1986, 1993, 1997, and 1999. In these years, the annual hours of unit derates varied between 21 (1986) and 165 (1993). The magnitude of annual energy loss due to unit derates varies between 13,100 MWh (1997) and 300,100 MWh (1993). Three of the derate years include a shutdown of all three units (1986, 1993, and 1999).
- For the entire 20-year period of simulation, the average annual hours of unit derates is 13, with an annual average energy loss of 19,200 MWh.
- For the entire 20-year period of simulation, the total annual energy loss due to both cooling tower operation and unit derates varies between 0 MWh (1992) and 331,600 MWh (1993). The annual average total energy loss due to both cooling tower operation and unit derates is 30,900 MWh.
- The worst year of the period of simulation is 1993, accounting for about 13 percent of the total simulation period energy loss due to cooling tower operation, and 78 percent of the total simulation period energy loss due to unit derates.

Although not summarized in detail herein, almost all of the Case 0 energy losses were associated with the NPDES limit for the 24-hour running average instream temperature, 90°F. In two years, 1986 and 1993, energy losses were also associated with the 1-hour running average instream limit of 93°F. In the entire simulation period there were no energy losses associated with the 24-hour running average instream temperature rise limit of 10°F.

Table 9. Baseline (Case 0) Results for BFN Simulations

Year	Cooling Tower Operation		Unit Derates			Total Energy Loss (1000 MWh)
	Approx Hrs of Operation*	Energy Loss (1000 MWh)	Approx Hrs of Derate*	Energy Loss (1000 MWh)	Max No. Units	
1985	41	1.3	0	0.0	-	1.3
1986	497	20.1	21	29.5	3	49.6
1987	505	18.1	0	0.0	-	18.1
1988	413	13.9	0	0.0	-	13.9
1989	18	0.3	0	0.0	-	0.3
1990	251	6.5	0	0.0	-	6.5
1991	423	16.3	0	0.0	-	16.3
1992	0	0.0	0	0.0	-	0.0
1993	793	31.5	165	300.1	3	331.6
1994	9	0.1	0	0.0	-	0.1
1995	718	27.8	0	0.0	-	27.8
1996	59	1.7	0	0.0	-	1.7
1997	266	9.4	23	13.1	1.2	22.5
1998	514	16.2	0	0.0	-	16.2
1999	598	23.8	46	40.5	3	64.3
2000	420	14.8	0	0.0	-	14.8
2001	131	4.1	0	0.0	-	4.1
2002	652	23.7	0	0.0	-	23.7
2003	94	3.4	0	0.0	-	3.4
2004	45	1.3	0	0.0	-	1.3
20 Year Total	6447	234.3	255	383.2	-	617.5
Avg Per Year	322	11.7	13	19.2	-	30.9

* Hours refer to calendar hours of cooling tower operation or unit derates

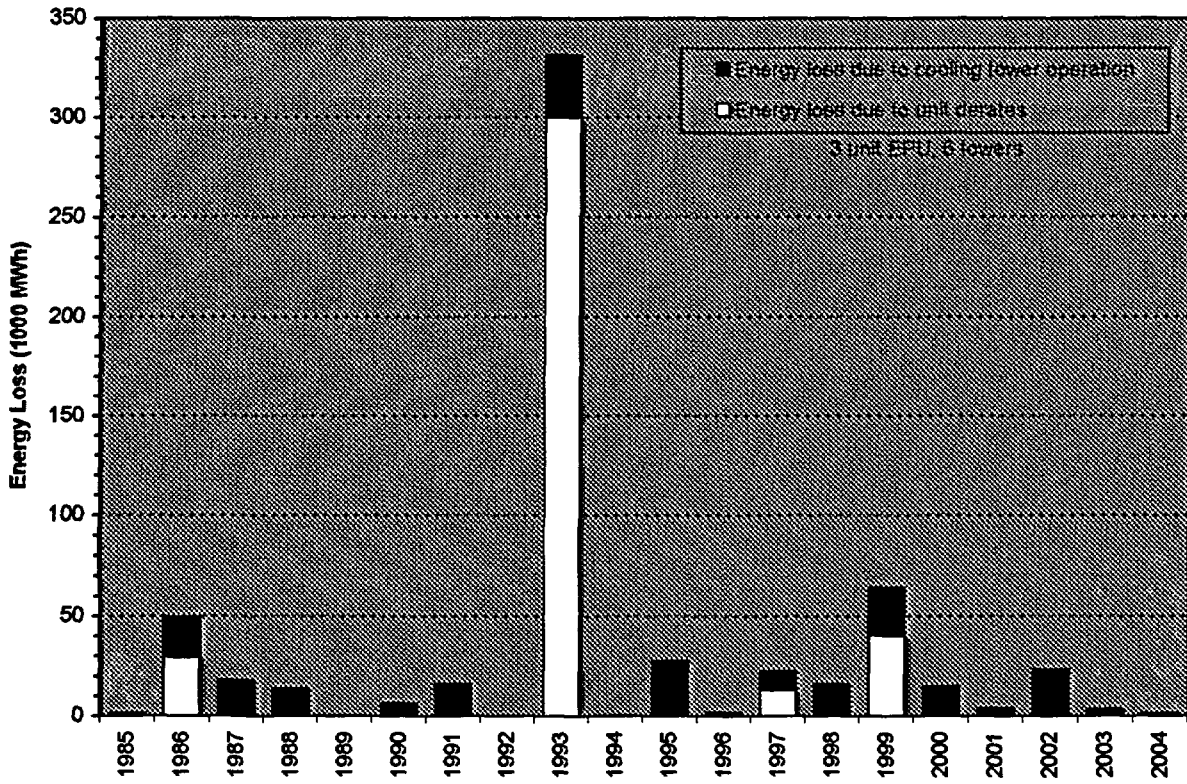

Figure 25. Baseline (Case 0) Results for BFN Simulations

Example Case 0 results for 1993 are given in Figure 26 and Figure 27. Figure 26 shows the generation for each unit for the entire year, along with the 24-hour running average river flow and river temperatures. Figure 27 shows the same information for a 10-day period in late July, when all of the 1993 derates were simulated to occur. The following observations are made.

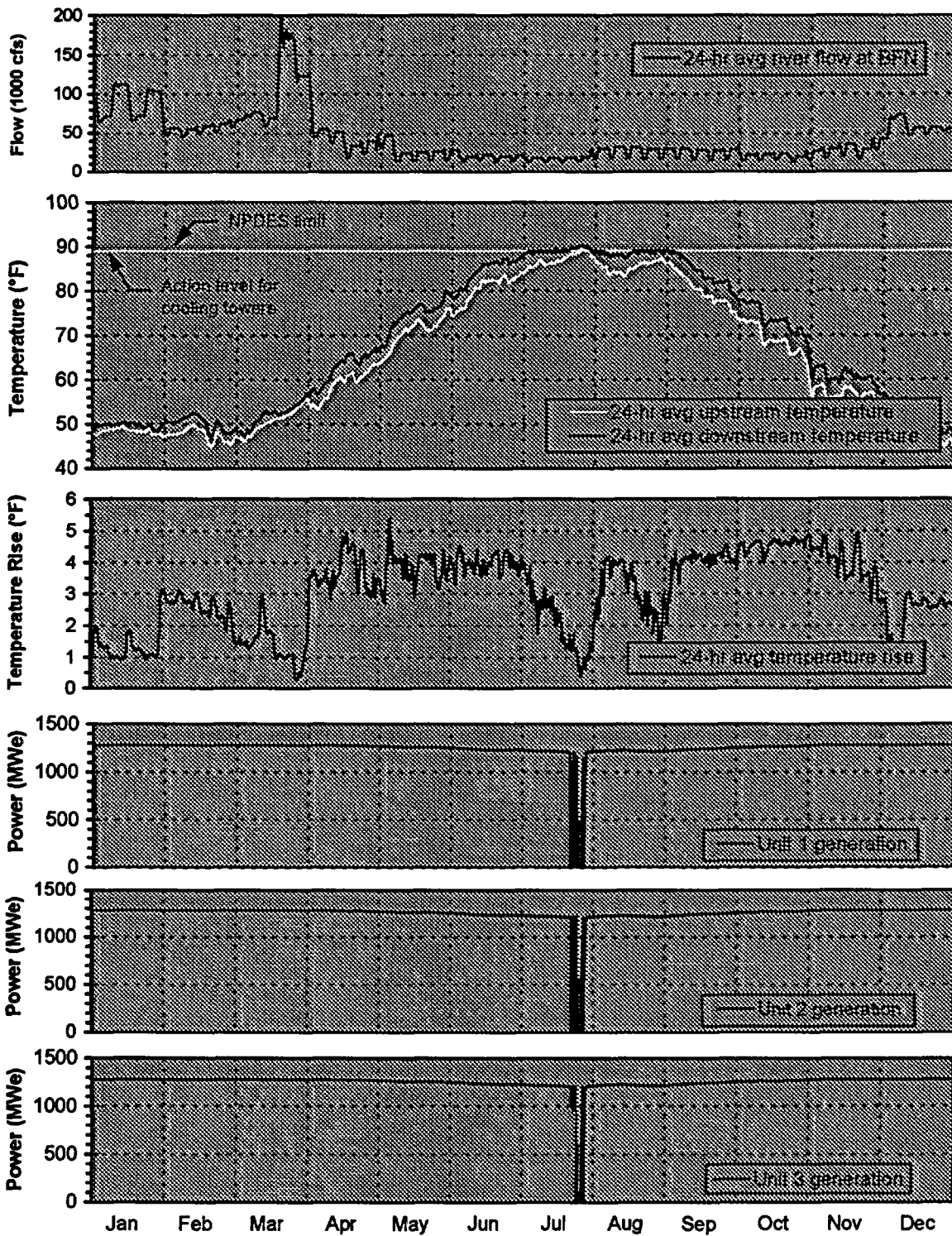

Figure 26. BFN Operation for 1993

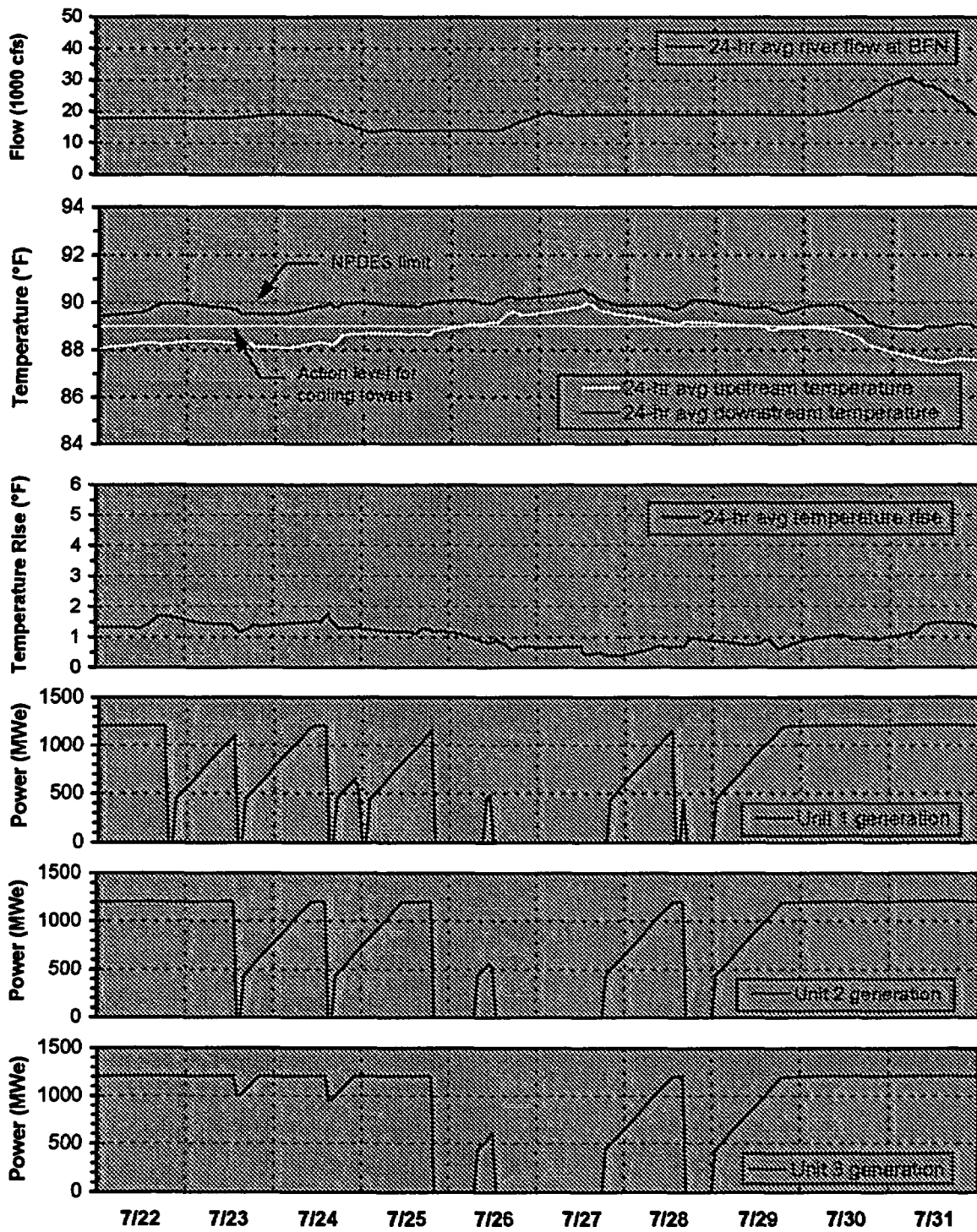

Figure 27. BFN Operation for Late July 1993

Figure 26

- For the first three months of the year, January through March, the flow in the river is high and cool. Under these conditions, generation of the units is near the maximum of 1280 MWe. Also, the dilution of the diffuser thermal effluent is high, keeping the temperature rise from upstream to downstream of the plant below 3°F.
- Beginning in April, when the river flow is reduced for filling the reservoir system, dilution of the diffuser effluent is reduced and the plant instream temperature rise increases to about 4°F. In response to warmer meteorology, the ambient river temperature begins to increase. The higher river temperature, in turn, reduces the efficiency of the units, causing generation to drop to about 1210 MWe by the middle of July.
- In early July, the downstream temperature reaches the action level for cooling tower operation, 89°F. The cooling towers are brought into service and the plant instream temperature rise drops. But the upstream ambient river temperature continues to rise, and by late July, even with all six cooling towers in service, the units must be derated to prevent the downstream temperature from exceeding the 90°F NPDES limit.
- Near the end of July, cooler meteorology causes the upstream ambient river temperature to drop. With this, the units can be returned to service. First, they are accompanied by cooling tower operation, but in early August the ambient river temperature becomes cool enough that the downstream temperature drops below the 89°F action level, and the cooling towers are removed from service.
- Near mid-August, the downstream temperature again climbs above the 89°F action level, and once more the cooling towers are brought into service. The cooling towers drop the instream temperature rise from about 4°F to about 2°F. In this event, the upstream ambient river temperature remains “level” and unit derates are not required. Cooling tower operation continues until early September, when the river temperature begins its descent towards winter conditions.
- From September to the end of the year, river temperatures continue to fall. The lower temperatures allow the efficiency of the units to increase, and generation climbs back to a level near 1280 MWe. With higher river flows and cool river temperatures, the instream temperature rise drops below 2°F by early December.

Figure 27

- On July 22nd, to prevent the downstream temperature from exceeding the 90°F NPDES limit, Unit 1 is derated to full shutdown. Unit 1 is derated first by the control process of the BFN hydrothermal model, which removes units from service in a manner opposite of the order that the units were placed on cooling towers (i.e., units are placed in helper-mode by Unit 3 first, Unit 2 second, and finally Unit 1).
- Shortly thereafter, the river temperature allows Unit 1 to return to service and begin ramping-up to full power. However, the next day, July 23rd, Unit 1 must again be derated to full shutdown. In fact, at the same time, Unit 2 must also be derated to full shutdown, as well as part of Unit 3. But again, a short time later, all of the units can be returned to service.
- The “see-saw” process of derating and returning units to service occurs again on July 24th, but on the 25th all three units must be derated to full shutdown. The next day, July 26th, the units are brought back into service for a short time, but again must be shut down. A similar attempt occurs late on July 27th through early July 28th. Finally, on July 29th, when the upstream ambient river temperature drops below about 89°F, all three units can be returned to service and ramp up to full power.
- On July 30th and 31st, falling upstream ambient river temperatures allow all three units to continue operating at full power without exceeding the downstream temperature limit. Note that during these events, the units, when in service, are accompanied by cooling tower operation.

In general, these results should be viewed only as a potential order of magnitude. The bottom line is that for Case 0, cooling tower operation will be required almost every year, and assuming the annual summertime climate is random and independent, the probability of significant unit derates is estimated to be about twenty percent in any given year. In the most extreme years, the resulting amount of annual energy loss could be as much as 30,000 MWh for cooling tower operation, and for unit derates, as much as 300,000 MWh. Over many years, the average Case 0 cooling tower energy loss is expected to be about 12,000 MWh per year, and the average unit derates about 20,000 MWh per year, making the total combined average cooling tower and derate energy loss of magnitude 32,000 MWh per year.

Sensitivity Assumptions

Whereas the model results are based on a rigid operational logic for the plant, in reality, the actual processes for initiating and ending cooling tower operation and unit derates will vary from event to event. This will be a consequence of factors such as forecast uncertainty, unexpected operating problems, and detailed operating procedures that cannot be accurately reproduced in the model. For example, it would seem very unlikely that the units would be operated up and down in a fashion depicted in Figure 27. To account for these and other uncertainties, sensitivity evaluations were performed. The changes in the baseline assumptions for each sensitivity case are summarized in Table 10. The following descriptions are provided for each case.

Case 1—Reduced Cooling Tower Availability

Over the years, unexpected problems with cooling tower equipment have been an issue in a number of BFN hydrothermal events. To evaluate unexpected problems with cooling tower reliability, Case 1 includes a simulation with changes in baseline assumption No. 15. Specifically, Tower 4 is assumed to be unavailable for service, so that only five cooling towers, rather than six, are on hand for helper-mode operation. Tower 4 is the 20-cell cooling tower that although currently planned (TVA, 2002), is not yet constructed.

Case 2—Uniform Load Reduction

As previously discussed (Plant Water Routing), since the cooling tower lift pumps cannot handle all of the flow from nine CCW pumps, a portion of the plant effluent must be bypassed directly to the river without treatment (i.e., when all three units are in helper-mode). Under these conditions, on the average, the most efficient manner to implement unit derates is to remove units from service sequentially (i.e., one unit at a time). When the first unit is removed from service, all of the CCW flow from the remaining units can be passed through the cooling towers, thereby eliminating any untreated bypass. From an operational standpoint, however, circumstances may arise when it is better to achieve a derate by reducing all three units uniformly. For example, if a large derate is required, it may be easier for the units to be returned to full power if the derate is spread lightly over all three units rather than carrying a large derate on a single unit. To evaluate the potential impact of such, Case 2 includes changes to baseline assumption No. 4, requiring derates to be made uniformly across all three units, rather than sequentially.

Table 10. Cases for Sensitivity Evaluations

Case	Units			Cooling Towers *						Description
	1	2	3	1	2	3	4	5	6	
0	120	120	120	ED16	ED16	BD16	BD20	ED16	ED16	<ul style="list-style-type: none"> • Baseline assumptions • 6 cooling towers
1	120	120	120	ED16	ED16	BD16	None	ED16	ED16	<ul style="list-style-type: none"> • Baseline assumption #15 changed to include only 5 cooling towers—Tower 4 is assumed to be unavailable for service • 5 cooling towers
2	120	120	120	ED16	ED16	BD16	BD20	ED16	ED16	<ul style="list-style-type: none"> • Baseline assumption #4 changed to include uniform load reduction among all units • 6 cooling towers
3	120	120	120	ED16	ED16	BD16	BD20	ED16	ED16	<ul style="list-style-type: none"> • Baseline assumption #47 changed to include re-entrainment of diffuser effluent • 6 cooling towers
4	120	120	120	ED16	ED16	BD16	BD20	ED16	ED16	<ul style="list-style-type: none"> • Baseline assumption #48 changed to include recirculation of diffuser effluent • 6 cooling towers
5	120	120	120	ED16	ED16	BD16	BD20	ED16	ED16	<ul style="list-style-type: none"> • Baseline assumption #3 changed to include a 24-hour downstream temperature derate trigger of 89.8°F rather than 90.0°F • 6 cooling towers
6	120	120	120	ED16	ED16	BD16	BD20	ED16	ED16	<ul style="list-style-type: none"> • Baseline assumption #29 changed to include a capability of 70% for Ecodyne towers • Baseline assumption #30 changed to include a capability of 90% for Balcke Durr towers • 6 cooling towers
7	120	120	120	ED16	ED16	BD16	BD20	ED16	ED16	<ul style="list-style-type: none"> • Baseline assumption #13 changed to include a condenser cleanliness of 80% rather than 85% • 6 cooling towers
8	120	120	120	ED16	ED16	BD16	BD20	ED16	ED16	<ul style="list-style-type: none"> • Baseline assumption #13 changed to include a condenser cleanliness of 90% rather than 85% • 6 cooling towers
9	120	120	120	ED16	ED16	BD16	BD20	ED16	ED16	<ul style="list-style-type: none"> • Baseline assumption #46 changed to include ambient entrainment coefficient set (1.0, 0.25, 0.18) for 1-unit, 2-unit, 3-unit operation rather than set (1.0, 0.25, 0.25) • 6 cooling towers
10	120	120	120	ED16	ED16	BD16	BD20	ED16	ED16	<ul style="list-style-type: none"> • Baseline assumption #50 changed to include uniform upstream ambient temperature equal to the Station 4 temperature at depth 5 feet • 6 cooling towers
11	120	120	120	ED16	ED16	BD16	BD20	ED16	ED16	<ul style="list-style-type: none"> • Baseline assumption #46 changed to include ambient entrainment coefficient set (1.0, 0.25, 0.18) for 1-unit, 2-unit, 3-unit operation rather than set (1.0, 0.25, 0.25) • Baseline assumption #47 changed to include re-entrainment of diffuser effluent • Baseline assumption #48 changed to include recirculation of diffuser effluent • Baseline assumption #50 changed to include uniform upstream ambient temperature equal to the Station 4 temperature at depth 5 feet • 6 cooling towers

* ED=Ecodyne tower
 BD=Balcke-Durr tower
 16=16 cells
 20=20 cells

Case 3—Diffuser Effluent Re-Entrainment

Partial re-entrainment of the diffuser plume is known to occur under conditions of low river flow. When the diffuser plume attempts to entrain a greater amount of ambient flow than is available from the upstream direction, the upper levels of the plume will tend to migrate upstream and then plunge back down to be mixed with the lower portions, resulting in a reduction of the mixing with the ambient flow. Thus, in Case 3, baseline assumption No. 47 is changed to include the potential impact of diffuser effluent re-entrainment. This is accomplished by adjusting the local ambient temperature profile. For each point in the ambient temperature profile, a local densimetric Froude number is defined as

$$F_r = \frac{V_r}{\sqrt{g \left(\frac{\rho_a - \rho_p}{\rho_a} \right) (Z_a - Z_b)}}, \quad (23)$$

where V_r is the average river velocity, $Z_a - Z_b$ is the elevation of the profile point relative to the bottom elevation of the river, ρ_a is the ambient water density at that elevation, and ρ_p is the density of the plume at the 5-foot compliance depth. If F_r is less than 1.0, it is assumed that the buoyancy of the plume is not sufficient to prevent part of the upper plume from traveling upstream and being drawn downward, increasing the apparent ambient temperature. The modified ambient temperature, T_a^1 at the depth is then computed by

$$T_a^1 = F_r * T_p + (1.0 - R_f) * T_a^0, \quad (24)$$

where R_f is a constant, T_a^0 is the original ambient temperature, and T_p is the plume temperature at the 5-foot depth. After new ambient temperatures have been computed for the entire profile, the mixing zone computation is performed again, using the new ambient profile to get a new plume temperature at the 5-foot depth. Note that in this process the instream temperature rise is still computed with the original ambient 5-foot depth temperature (i.e., from Station 4). Based on past experience with the unstratified diffuser model, a value of 0.2 is considered reasonable for R_f .

Case 4—Diffuser Effluent Recirculation

During periods of low river flow, a large counterclockwise eddy forms in Wheeler Reservoir in the vicinity of the diffusers. This eddy can transport diffuser effluent upstream where it is recirculated into the plant intake. In Case 4, baseline assumption No. 48 is changed to include the potential impact of this recirculation.

To estimate the potential increase in intake temperature resulting from diffuser effluent recirculation, the ratio of river flow, Q_r , to total diffuser discharge flow, Q_d , is determined by

$$R_q = \frac{Q_r}{Q_d}. \quad (25)$$

If R_q is less than -1, the recirculation fraction is set to a constant, r_c ,

$$f = r_c. \quad (26)$$

If R_q is greater than or equal to -1, the recirculation fraction is defined as

$$f = \frac{12r_c}{((R_q^3 + 4) * R_q + 15)}. \quad (27)$$

Once the recirculation fraction is determined, the new intake temperature is computed by

$$T_i^1 = T_i^0 + f * (T_p - T_i^0), \quad (28)$$

where T_i^1 is the new intake temperature, T_i^0 is the original intake temperature, and T_p is the plume temperature at the 5-foot depth from the previous time step. The plume temperature from the previous step is used in order to approximate the travel time from the diffuser to the plant intake. Based on past experience, a value of 0.25 is considered reasonable for the constant r_c .

Case 5—Derate Trigger 89.8°F

In the hydrothermal simulations, the model has “perfect knowledge” of the upstream temperature for the next hour, and by trial-and-error adjusts the generation to prevent exceeding the plant operating limits. In practice, knowledge of the future conditions of the river is limited to a forecast, which can include considerable uncertainty. Also, as previously discussed (Other Model Features), the model includes a quasi-unsteady formulation, wherein transients in the plant cooling system are assumed to steady-out within the time step of the model, one hour. In actual operation, after a derate is implemented, it may take longer than one hour for the excess heat to “flush” from the system and propagate to the downstream end of the plant mixing zone. This particularly is true for low river flow. Also, recall that the actual operation of the plant is based on monitoring every 15 minutes, not one hour. The bottom line is, that in practice, it will take time to successfully implement unit derates. If a trigger of 90°F is used for unit derates, corresponding to the downstream NPDES temperature limit, it is possible that by the time the load reduction has been implemented, the downstream temperature has exceeded the limit. In

light of these factors, Case 5 includes changes to baseline assumption No. 3, lowering the trigger for derates from 90°F to 89.8°F (24-hour running average downstream temperature).

Case 6—Reduced Cooling Tower Capability

Cooling tower performance can be expected to degrade over time due to shifting of the distribution channels, clogging of nozzles and fill, failure of fill material, wearing of fan tip seals, and so on. The result of this degradation would be increased tower discharge temperatures and a small increase in helper-mode discharge, due to decreased evaporation from the tower. In recognition of this degradation, Case 6 includes changes to baseline assumption No. 29, changing the capability of the Ecodyne cooling towers from 80 percent to 70 percent, and changes to baseline assumption No. 30, changing the capability of the Balcke-Durr cooling towers from 96 percent to 90 percent. Cooling tower performance curves generated with these lower capabilities are shown for assumed maximum and design water flowrates in Figure 28.

Case 7 and Case 8—Reduced and Enhanced Condenser Cleanliness

Condenser tube fouling increases flow velocity, reduces heat transfer, increases back pressure and decreases efficiency of the condenser, resulting in increased condenser exit temperature and heat flux. A condenser cleanliness factor (CCF) of 85 percent was used for baseline assumption No. 13. In Case 7 this assumption was changed by decreasing the condenser cleanliness to 80 percent. In Case 8 the condenser cleanliness factor was increased to 90 percent. The effect of the cleanliness factor on the CCW temperature rise across the condenser is shown in Figure 29.

Case 9—Reduced 3-Unit Diffuser Effluent Entrainment

The diffuser entrainment coefficients for one and two operating diffusers are based on a relatively large number of samples from one- and two-unit open-mode operation. As previously emphasized, there is little calibration data available for the operation of three diffusers, since such occurs only when one or more units are in helper-mode. Furthermore, most experience with helper-mode operation has been for two units operating with one unit in open-mode with its full CCW flow routed to its diffuser, and the other unit on towers with its discharge split between the two remaining diffusers. This results in significant imbalance in the discharge flow and temperature among the three diffuser legs.

Towers 1,2,5,6 - Water Flow 255000 GPM

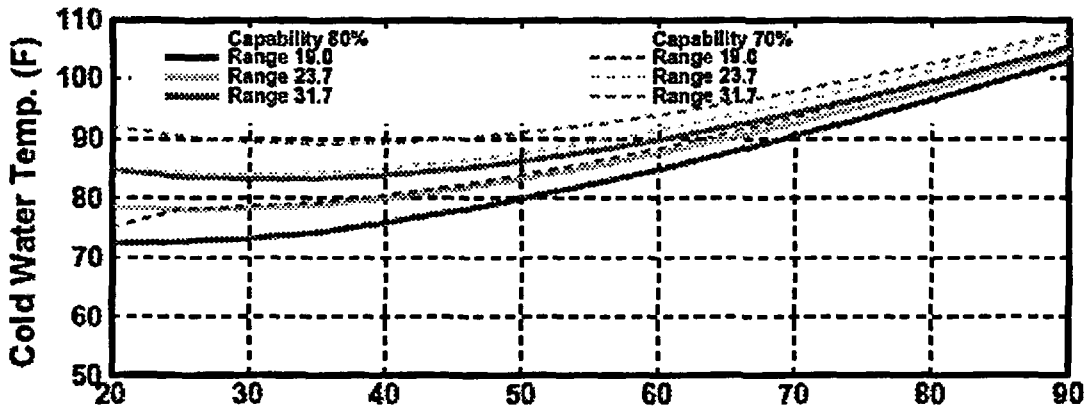

Tower 3 - Water Flow 281800 GPM

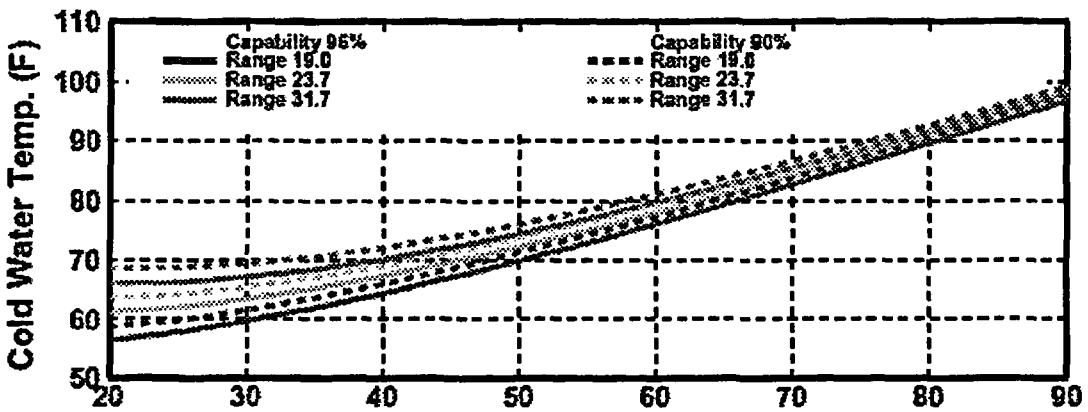

Tower 4 (proposed) - Water Flow 352250 GPM

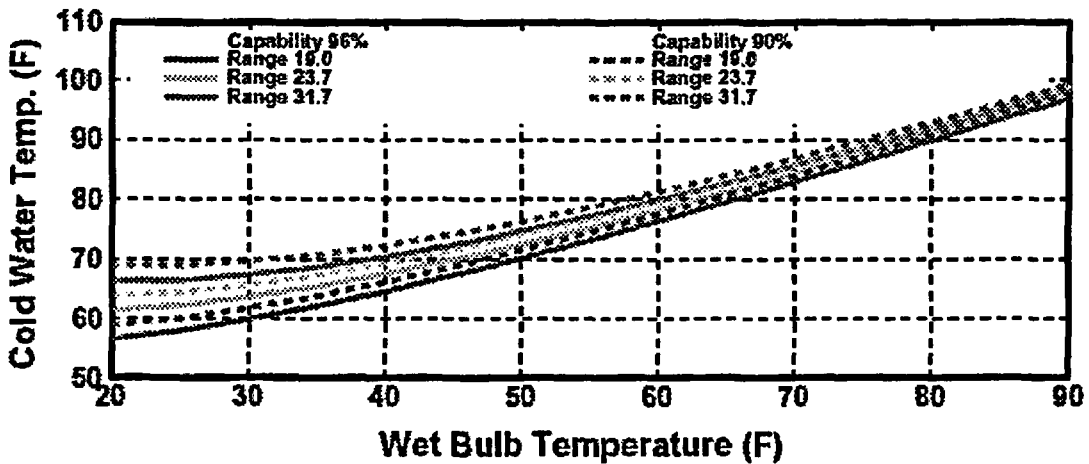

Figure 28. BFN Cooling Tower Performance Curves with Normal and Reduced Capabilities

BFN Condenser Rise at Full Load

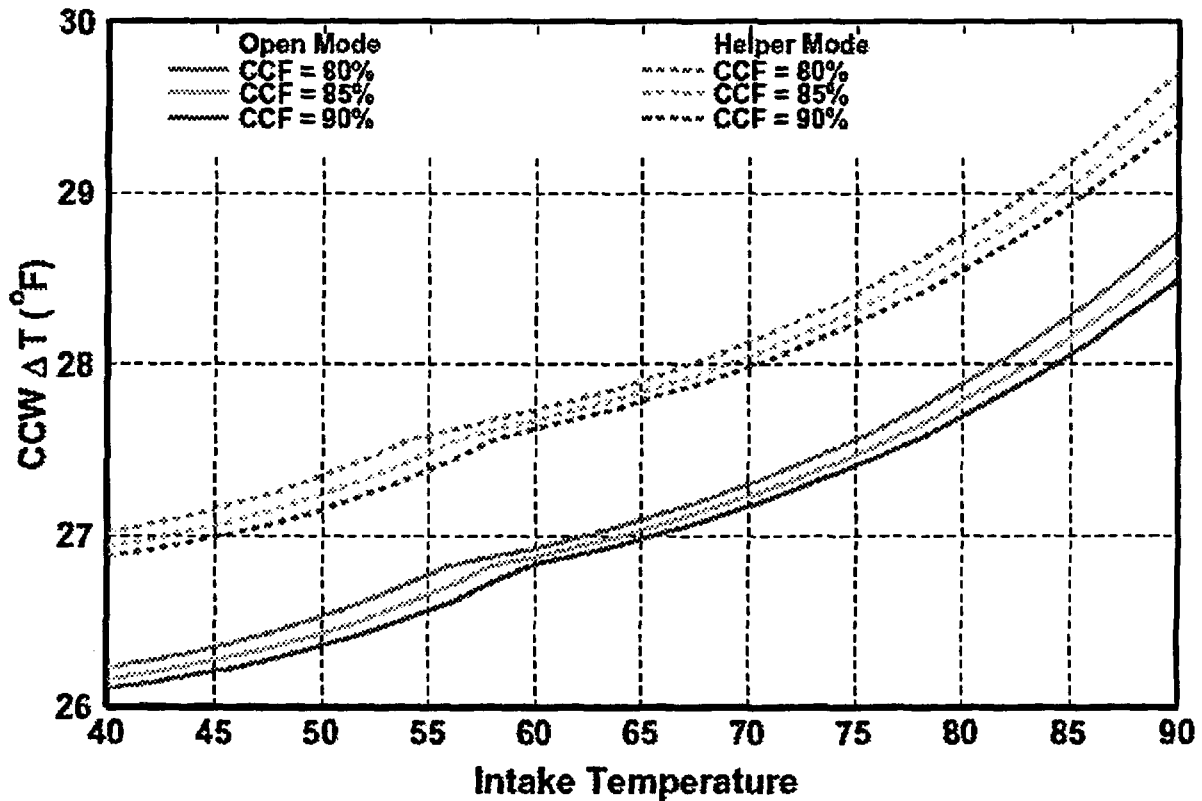
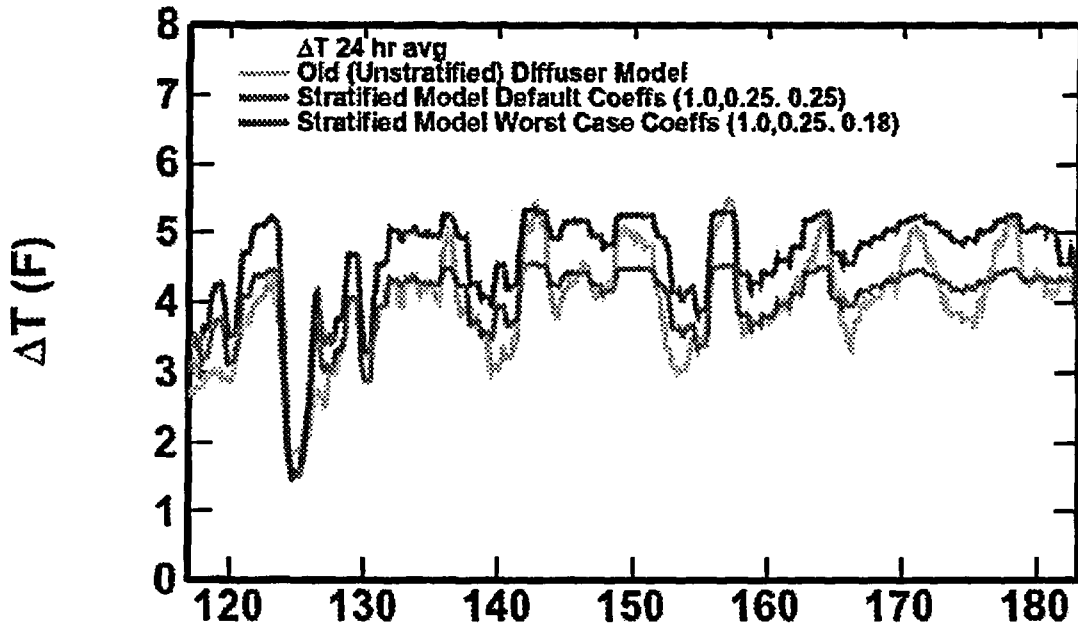

Figure 29. Effect of Condenser Cleanliness Factor on Condenser Temperature Rise

In baseline assumption No. 46, the diffuser entrainment coefficients for the stratified diffuser model were set to 1.0, 0.25, and 0.25 for one, two, and three active diffusers, respectively. Since the unstratified diffuser model tends to compute a higher instream temperature rise than that of the stratified diffuser model, and since the unstratified diffuser model is rooted in a physical model study containing measurements with three unit operation (e.g., rather than prototype data with questionable three leg operation), it was decided in Case 9 to establish a probable worst case for three active diffusers by using an entrainment coefficient in the stratified diffuser model that reproduces the peak instream temperature rise computed by the unstratified diffuser model. In this manner, for Case 9, assumption No. 46 was changed to use an entrainment coefficient of 0.18 for the operation of three active diffusers (i.e., rather than 0.25). The instream temperature rises computed by the stratified and unstratified models are shown in Figure 30 for 1993.

BFN Instream Temperature Rise



BFN River Flow

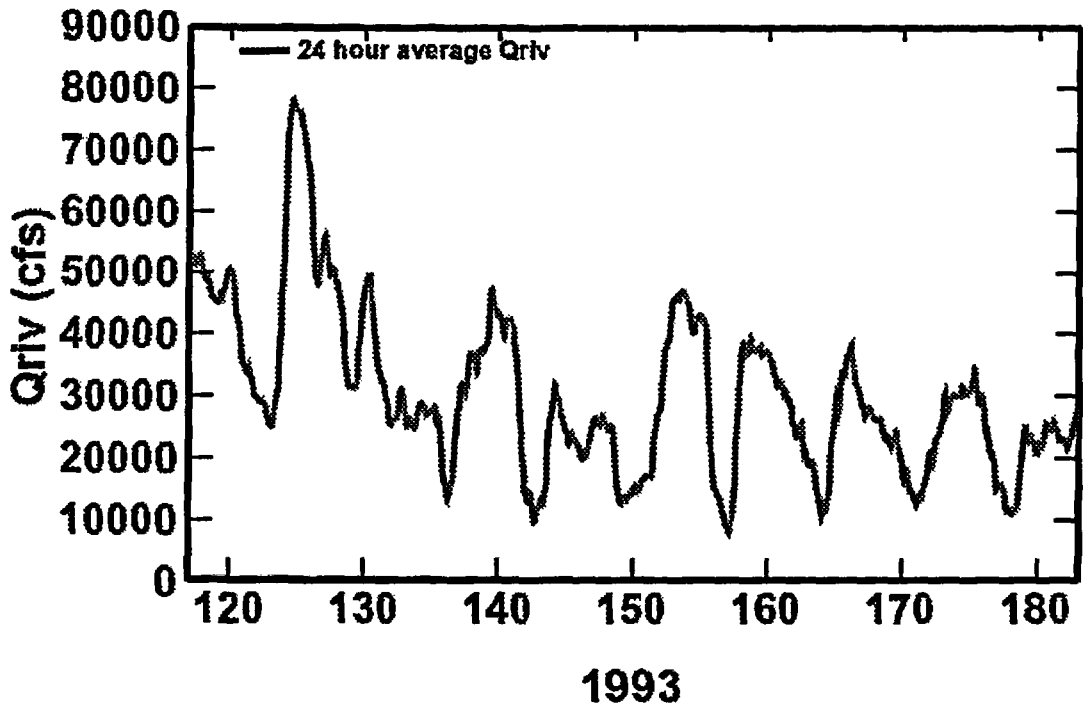

Figure 30. Instream Temperature Rises Computed by Unstratified and Stratified Models for

Case 10—Uniform Upstream Temperature

To examine the impact of reservoir stratification, Case 10 includes changes to baseline assumption No. 50, assigning the upstream ambient river temperature to be uniform top to bottom and equivalent to that of the historical data at the 5-foot depth at BFN Station 4. In practice, since it is weak, upstream river stratification can unexpectedly be disrupted by events such as a local thunderstorm. When this occurs, the warmer surface water is mixed with the cooler bottom water, thereby increasing the plant intake temperature and the water temperature at the depth of the diffusers, which subsequently increases temperatures in the diffuser mixing zone.

Case 11—Combination of Factors

In recognition that many of the above behaviors and conditions can act concurrently, Case 11 includes changes to a combination of baseline assumptions, primarily those that perhaps contain the greatest uncertainty. The combination includes changes to baseline assumptions No 46 (Case 9—Diffuser Effluent Entrainment), No. 47 (Case 3—Diffuser Effluent Re-Entrainment), No. 48 (Case 4—Diffuser Effluent Recirculation), and No. 50 (Case 10—Uniform Upstream Temperature). Note that all these factors are related to the hydrothermal characteristics of receiving river water and the interaction of the plant withdrawal and discharge with this water.

Sensitivity Results

Results of the cases showing the range of computed energy losses for each year of the simulation are given in Table 11. Figure 31 illustrates the ranges for cooling tower operation whereas Figure 32 and Figure 33 do the same for unit derates and combined cooling tower operation and unit derates, respectively. The following observations are emphasized.

Figure 31—Cooling Tower Operation

- The overall impact of the sensitivity cases is to increase the potential range of energy loss for each year of the simulation. Since most of the cases include changes that increase the magnitude of waste heat and/or the ability to dissipate the waste, this observation is not unexpected.
- In most years, the magnitude of energy loss is at least twice as much as that of the Case 0 results.

Table 11. Results for Sensitivity Cases

Year	Cooling Tower Operation			Unit Derates			Total Energy Loss		
	Min of All Cases (1000 MWh)	Case 0 (1000 MWh)	Max of All Cases (1000 MWh)	Min of All Cases (1000 MWh)	Case 0 (1000 MWh)	Max of All Cases (1000 MWh)	Min of All Cases (1000 MWh)	Case 0 (1000 MWh)	Max of All Cases (1000 MWh)
1985	1.2	1.3	19.0	0.0	0.0	0.0	1.2	1.3	18.7
1986	16.9	20.1	48.0	5.7	29.5	185.7	29.3	49.6	233.9
1987	17.4	18.1	45.0	0.0	0.0	0.0	17.4	18.1	45.5
1988	13.7	13.9	38.0	0.0	0.0	0.1	13.7	13.9	38.2
1989	0.3	0.3	8.0	0.0	0.0	0.1	0.3	0.3	8.4
1990	5.8	6.5	46.0	0.0	0.0	1.1	5.8	6.5	47.5
1991	15.7	16.3	48.0	0.0	0.0	77.9	15.7	16.3	125.7
1992	0.0	0.0	14.0	0.0	0.0	0.0	0.0	0.0	14.1
1993	29.8	31.5	59.0	190.6	300.1	395.6	225.8	331.6	425.4
1994	0.1	0.1	7.0	0.0	0.0	0.0	0.1	0.1	6.6
1995	27.5	27.8	51.0	0.0	0.0	69.2	27.8	27.8	120.6
1996	1.7	1.7	27.0	0.0	0.0	0.8	1.7	1.7	27.3
1997	9.1	9.4	25.0	8.7	13.1	23.3	20.0	22.5	48.4
1998	15.5	16.2	50.0	0.0	0.0	0.8	15.5	16.2	50.7
1999	22.2	23.8	47.0	31.3	40.5	95.4	55.4	64.3	142.2
2000	14.4	14.8	49.0	0.0	0.0	1.2	14.4	14.8	50.0
2001	3.6	4.1	23.0	0.0	0.0	0.0	3.6	4.1	23.1
2002	22.9	23.7	63.0	0.0	0.0	45.3	22.9	23.7	107.8
2003	3.2	3.4	18.0	0.0	0.0	0.0	3.2	3.4	17.6
2004	1.2	1.3	17.0	0.0	0.0	0.0	1.2	1.3	16.7

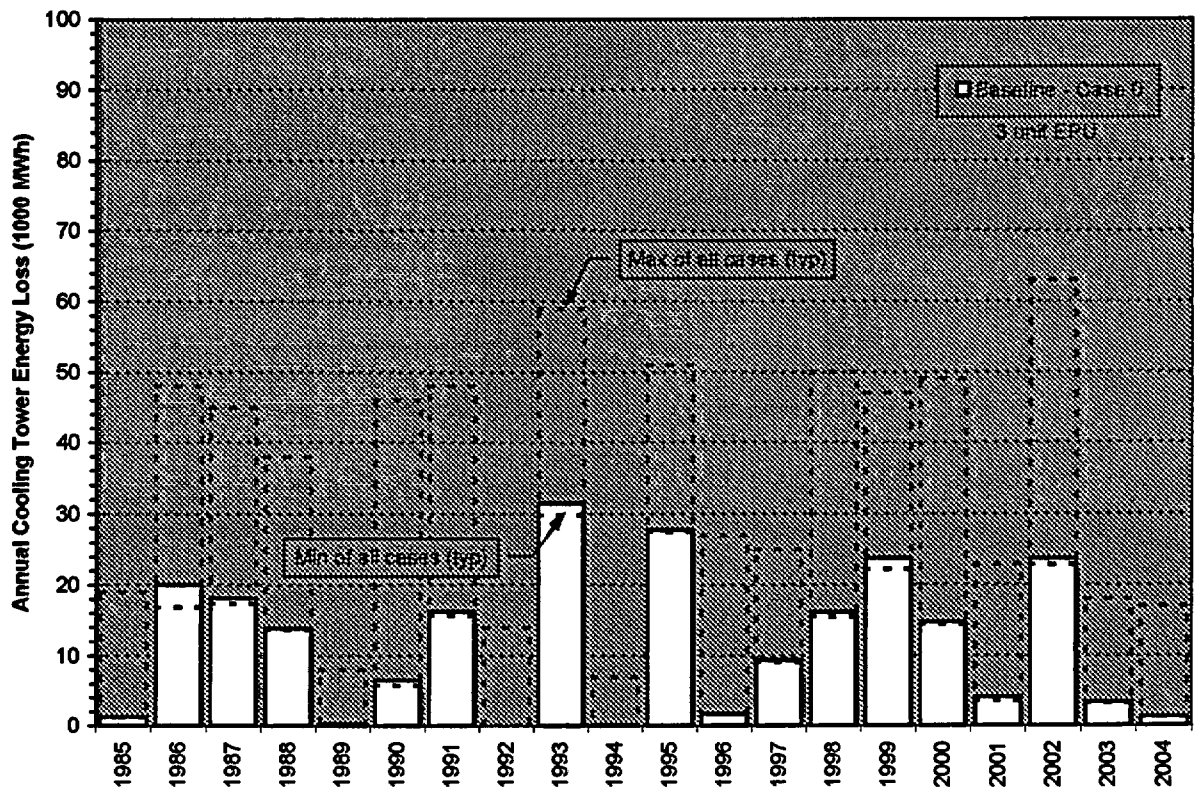

Figure 31. Range of Annual Cooling Tower Energy Loss for Sensitivity Cases

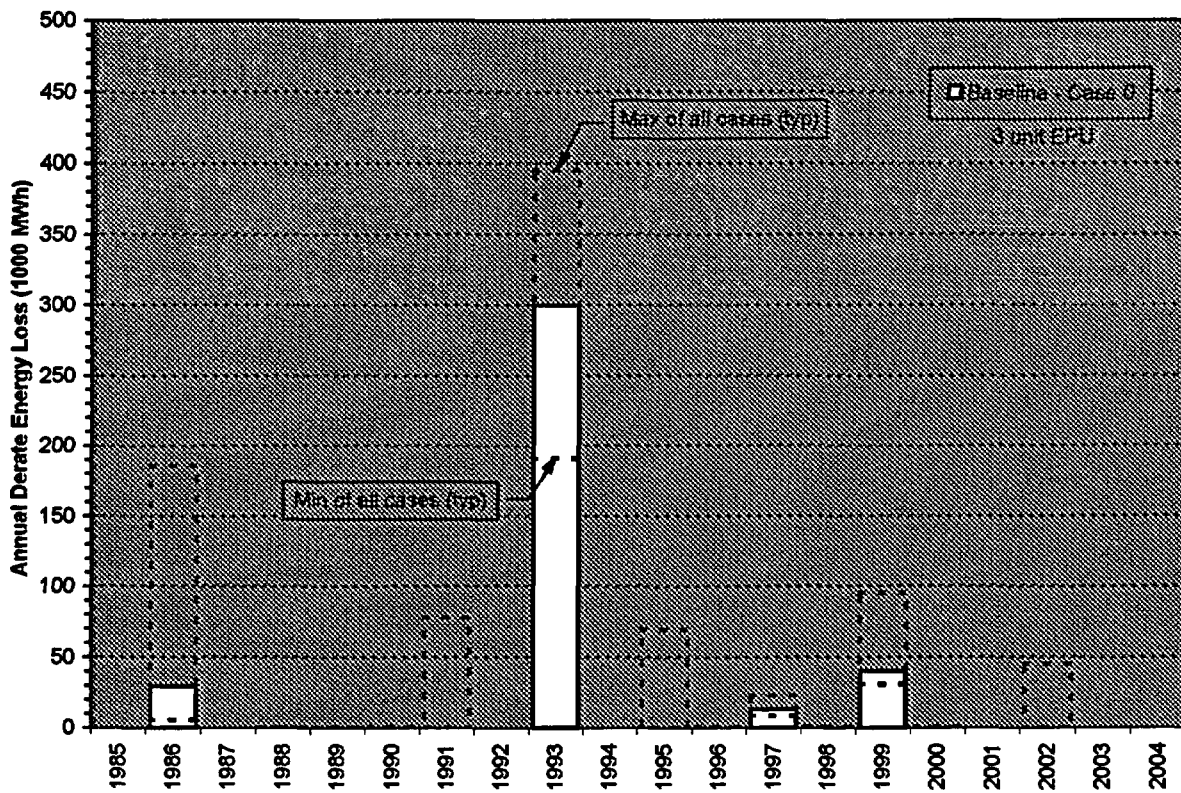

Figure 32. Range of Annual Derate Energy Loss for Sensitivity Cases

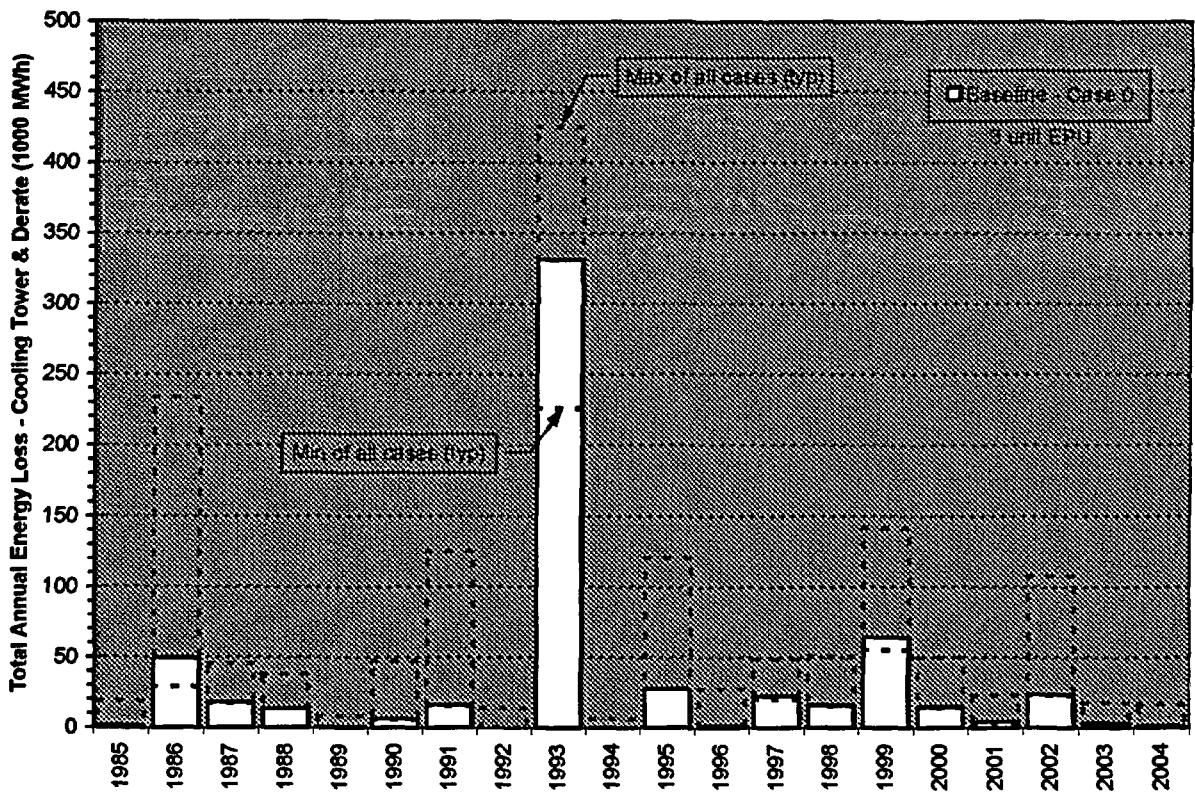

Figure 33. Range of Total Energy Loss for Sensitivity Cases

- The largest annual maximum energy loss for cooling tower operation increases from 31,500 MWh in 1993 to 63,000 MWh in 2002. Although not cited in Figure 31, 63,000 MWh occurs for Case 11 (i.e., the case including a combination of uncertainty factors). For this case, the extreme year for cooling tower operation shifts from 1993 to 2002. This is because 2002 includes a long period of elevated, but not necessarily extreme, ambient river temperatures. For Case 11 conditions, cooling tower operation is required much more extensively during this period than for Case 0 conditions. In contrast, 1993 is characterized by a shorter term extreme temperature event in late July and early August, as shown in Figure 27.

Figure 32—Unit Derates

- As found for cooling towers, and for the same reason, the overall impact of the sensitivity cases is to increase the potential range of energy loss for unit derates.
- The sensitivity cases produce 13 years that include unit derates, compared to 4 for Case 0 conditions. However, only in 7 years are derates significant—1986, 1991, 1993, 1995, 1997, 1999, and 2002.
- The largest annual unit derate energy loss is again that for 1993, once more dominating over the other derate years, and increasing from 300,100 MWh (Case 0) to 395,600 MWh. Although not cited in Figure 32, this occurs for Case 1, BFN operation with only five cooling towers.

Figure 33—Cooling Tower Operation and Unit Derates

- For the entire 20-year simulation period, the largest total annual energy loss due to both cooling tower operation and unit derates increases from 331,600 MWh (Case 0) to 425,400 MWh, and again occurs for 1993. Although not cited in Figure 33, this occurs for Case 1, BFN operation with only five cooling towers.
- Significant increases in the potential range of total energy loss occur for years 1986, 1991, 1995, 1999, and 2002. In all of these years, the largest fraction of the increase is due to additional derate energy losses. Also, although not cited in Figure 33, the maximum loss for all these years is defined by Case 11 (i.e., the case including a combination of uncertainty factors).

Results for the cases showing the total energy losses for the entire 20-year period of simulation and the average energy losses per year are given in Table 12. Figure 34 illustrates the average energy losses per year for each case. The following observations are emphasized.

- For the entire 20-year simulation period, the largest average annual energy loss due to cooling tower operation occurs for Case 11 (i.e., the case including a combination of uncertainty factors). The average loss is 35,100 MWh per year, 3 times larger than the average annual loss for Case 0 (11,700 MWh per year).
- For the entire 20-year simulation period, the largest average annual energy loss due to unit derates also occurs for Case 11. The average loss is 39,600 MWh per year, about 2 times larger than the average annual loss for Case 0 (19,200 MWh per year).
- For the entire 20-year simulation period, the largest total average annual energy loss due to both cooling tower operation and unit derates again occurs for Case 11. The average loss is 74,600 MWh per year, about 2.4 times larger than the average annual loss for Case 0 (39,900 MWh per year).

The results shown in Table 12 and Figure 34 also shed light on the general impact of the changes in baseline assumptions for each sensitivity case. Since some of the results are counterintuitive, it is important to provide comments for each case. As such, compared to the Case 0 results, the following comments are provided.

- Case 1 (reduced cooling tower availability)—With only five rather than six cooling towers, the total energy loss increases because of the reduced treatment capacity for the plant waste heat (42,700 MWh per year vs. 30,900 MWh per year for Case 0). This forces the plant to take deeper derates (31,300 MWh per year vs. 19,200 MWh per year for Case 0). However, the energy loss due to cooling tower operation is slightly less because there are fewer cooling towers, and because cooling towers are removed from service when a derate causes unit shutdowns (11,500 MWh per year vs. 11,700 MWh per year for Case 0).
- Case 2 (uniform load reduction)—On the average, uniform vs. sequential load reductions slightly increases the total energy loss because, as previously discussed, a higher volume of untreated waste heat is bypassed directly to the river during periods when all three units are in helper-mode (34,900 MWh per year vs. 30,900 MWh per year for Case 0). This forces the plant to take slightly deeper derates (23,200 MWh per year vs. 19,200 MWh per year for Case 0), but has essentially no impact on the energy loss for cooling tower operation (11,700 MWh per year vs. 11,700 MWh per year for Case 0).

Table 12. Total and Average Energy Loss for Sensitivity Cases

Case	Energy Loss Due to Cooling Tower Operation		Energy Loss Due to Unit Derates		Energy Loss Due to Cooling Tower Operation and Unit Derates	
	Total for 20 Yrs (1000 MWh)	Average Per Yr (1000 MWh)	Total for 20 Yrs (1000 MWh)	Average Per Yr (1000 MWh)	Total for 20 Yrs (1000 MWh)	Average Per Yr (1000 MWh)
0	234.3	11.7	383.2	19.2	617.5	30.9
1	229.4	11.5	625.1	31.3	854.5	42.7
2	233.3	11.7	464.6	23.2	697.9	34.9
3	451.1	22.6	527.4	26.4	978.5	48.9
4	240.9	12.0	337.1	16.9	578.0	28.9
5	234.3	11.7	383.2	19.2	617.5	30.9
6	241.9	12.1	444.9	22.2	686.8	34.3
7	236.2	11.8	380.4	19.0	616.6	30.8
8	230.2	11.5	395.9	19.8	626.1	31.3
9	334.4	16.7	438.0	21.9	772.4	38.6
10	293.2	14.7	303.5	15.2	596.7	29.8
11	701.7	35.1	791	39.6	1492.7	74.6

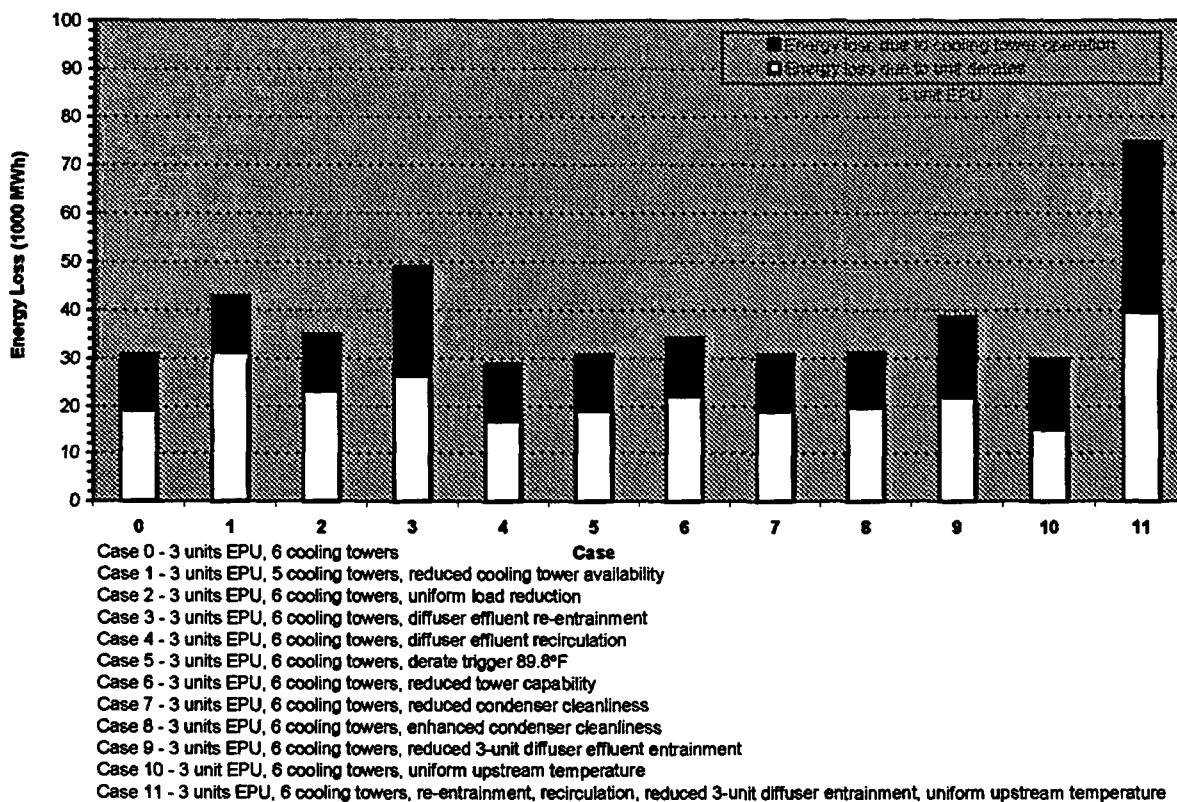

Figure 34. Average Energy Loss Per Year for Sensitivity Cases

- **Case 3 (diffuser effluent re-entrainment)**—The overall effect of having slightly warmer ambient temperatures during low river flow events, caused by the diffuser effluent re-entrainment, is to reduce the dilution of the plant thermal effluent in the diffuse mixing zone and increase the total energy loss (48,900 MWh per year vs. 30,900 MWh per year for Case 0). This forces the plant to take deeper derates (26,400 MWh per year vs. 19,200 MWh per year for Case 0) and to increase cooling tower operation (22,600 MWh per year vs. 11,700 MWh per year for Case 0).
- **Case 4 (diffuser effluent recirculation)**—One would expect the results for this case to be somewhat similar to Case 3, since it also is related to the low-flow buildup of thermal effluent in the vicinity of the plant. However, in contrast, the overall impact of increasing the intake temperature by recirculating part of the plant discharge is to slightly reduce the average total energy loss, at least for the conditions of the simulations conducted herein (28,900 MWh per year vs. 30,900 MWh per year for Case 0). A closer examination of the model results shows that the net effect of a slightly higher intake temperature during low-flow events is to cause the plant to initiate cooling tower operation earlier. This is seen by the results for the average annual energy loss due to cooling towers, which is slightly higher for Case 4 (12,000 MWh per year vs. 11,700 MWh per year for Case 0). Earlier operation of the cooling towers, in turn, reduces the running 24-hour average downstream temperature for a short period of time, compared to Case 0, and postpones the start of derate events, thereby reducing the average derate energy loss (16,900 MWh per year vs. 19,200 MWh per year for Case 0).

In connection with the Case 3 and Case 4 results it is valuable to make the following two additional comments.

- In terms of the dilution of the plant effluent, the impact of warmer ambient river temperatures will be more dramatic than that due to a higher plant intake temperature. For example, consider a 1°F increase in the plant intake temperature vs. a 1°F increase in the ambient river temperature. In the absence of cooling tower operation, a 1°F increase in the plant intake temperature will yield an increase in the plant effluent temperature of about 1°F. In the river, this increase will be reduced by the amount of dilution in the mixing zone. For example, if a dilution factor of four were found applicable for low-flow conditions, the corresponding increase in the compliance temperature at the downstream end of the mixing zone will be 0.25°F. In contrast, if the ambient river temperature is warmed by 1°F, the corresponding increase in the compliance temperature at the downstream end of the mixing zone also will be of magnitude 1°F. In a similar fashion, these behaviors are apparent in the Case 3 and Case 4 results. In Case 4, the higher

intake temperatures resulting from effluent recirculation yield a more subtle increase in the downstream compliance temperature, prompting earlier operation of the cooling towers and reducing derate energy loss (compared to Case 0). In Case 3, the higher ambient river temperature resulting from effluent re-entrainment yields a more dramatic increase in the downstream compliance temperature, again prompting earlier operation of the cooling towers, but also more quickly forcing the plant to initiate load reductions and increasing the derate energy loss (compared to Case 0).

- In practice, the Case 4 results, and some of the other cases to follow, call attention to the potential benefit of improving river temperature forecasts and careful operation of the CCW cooling system. In general, it is undesirable to operate cooling towers, due to the accompanying increase in plant service load. However, in hydrothermal events potentially culminating in unit derates, the magnitude of the derates can be reduced, and perhaps eliminated altogether, by operating cooling towers earlier rather than later. Improving the long-term forecast for river temperature will help identify when such benefits are likely and reduce overall plant energy losses.
- Case 5 (derate trigger 89.8°F)—The impact of reducing the derate trigger from 90°F to 89.8°F is negligible in terms of the average annual total energy loss (30,900 MWh per year for both Case 5 and Case 0). A closer examination of the model results shows that in leading up to and following derate events, the downstream compliance temperature did not linger extensively in the range between 89.8°F and 90°F. As such, unit derates occurred in essentially the same manner for both cases (19,200 MWh per year for both Case 5 and Case 0). Similarly, since the trigger for cooling tower operation was unchanged (89°F), the cooling tower operation also was essentially the same (11,700 MWh per year for both Case 5 and Case 0).
- Case 6 (reduced tower capability)—By reducing the capability of the cooling towers, the total energy loss increases slightly because of the reduced treatment capacity for the plant waste heat (34,300 MWh per year vs. 30,900 MWh per year for Case 0). This forces the plant to take slightly larger derates (22,200 MWh per year vs. 19,200 MWh per year for Case 0) and to operate the cooling towers a little more extensively (12,100 MWh per year vs. 11,700 MWh per year for Case 0).

- **Case 7 (reduced condenser cleanliness)**—The impact of reducing condenser cleanliness is counterintuitive in a manner similar to that of increasing the plant intake temperature by effluent recirculation (i.e., Case 4). A lower condenser cleanliness increases the effluent temperature and causes the plant to initiate cooling tower operation earlier. As such, results for the average annual energy loss due to cooling tower operation are slightly higher (11,800 MWh per year vs. 11,700 MWh per year for Case 0). Earlier operation of the cooling towers, in turn, slightly reduces the average derate energy loss (19,000 MWh per year vs. 19.2 MWh per year for Case 0). Overall, the reduction in derate energy loss outweighs the increase in cooling tower operation to yield a very slight reduction in the total energy loss (30,800 MWh per year vs. 30,900 MWh per year for Case 0).
- **Case 8 (increased condenser cleanliness)**—The impact of increasing condenser cleanliness is the opposite of that found for reducing condenser cleanliness. A higher condenser cleanliness decreases the plant effluent temperature and delays cooling tower operation. As such, results for the average annual energy loss due to cooling tower operation are slightly lower (11,500 MWh per year vs. 11,700 MWh per year for Case 0). The delay in cooling tower operation, however, increases the downstream compliance temperature and promotes higher energy loss due to unit derates (19,800 MWh per year vs. 19,200 MWh per year for Case 0). Overall, the increase in derate energy loss outweighs the decrease in cooling tower operation to yield a very slight increase in the total energy loss (31,300 MWh per year vs. 30,900 MWh per year for Case 0).
- **Case 9 (reduced 3-unit diffuser effluent entrainment)**—The impact of reducing the 3-unit entrainment coefficient from 0.25 to 0.18 is to reduce the dilution of the diffuser effluent for such operation, thereby increasing downstream compliance temperatures. The change is large enough to increase both cooling tower operation (16,700 MWh per year vs. 11,700 MWh per year for Case 0) and unit derates (21,900 MWh per year vs. 19,200 MWh per year for Case 0). As a result, the total energy loss also increases (38,600 MWh per year vs. 30,900 MWh per year for Case 0).

- **Case 10 (uniform upstream temperature)**—For the current model formulation, the results obtained with a uniform upstream temperature are also counterintuitive to expectations. As previously discussed, assuming the upstream temperature top to bottom to be equivalent to that at the 5-foot depth at BFN Station 4 increases the plant intake temperature and reduces the dilution of the plant effluent in the mixing zone. One would expect this to increase downstream temperatures, and, at first glance, increase the total energy loss associated with maintaining compliance with the NPDES limits. But in a manner similar to that of Case 4, a higher downstream temperature causes the plant to initiate cooling tower operation earlier and reduces unit derates. As such, results for the average energy loss due to cooling tower operation are higher (14,700 MWh per year vs. 11,700 MWh per year for Case 0) and the average derate energy loss is lower (15,200 MWh per year vs. 19,200 MWh per year for Case 0). Overall, the reduction in derate energy loss outweighs the increase in cooling tower operation to yield a very slight reduction in the total energy loss (29,800 MWh per year vs. 30,900 MWh per year for Case 0).
- **Case 11 (re-entrainment, recirculation, reduced 3-unit diffuser entrainment, uniform upstream temperature)**—The overall effect of a combination of uncertainty factors associated with the plant withdrawal and mixing zones is to significantly increase the downstream compliance temperature, and subsequently to increase the corresponding amount of cooling tower operation (35,100 MWh per year vs. 11,700 MWh per year for Case 0) and unit derates (39,600 MWh per year vs. 19,200 MWh per year for Case 0). As such, a significant increase is obtained for the total energy loss (74,600 MWh per year vs. 30,900 MWh per year for Case 0).

Results for the cases showing the energy losses for the worst year of the period of simulation are given in Table 13 and illustrated in Figure 35. The following observations are emphasized.

- For each case, 1993 is the worst year, always yielding the largest magnitude of combined cooling tower operation and derate energy losses. In all cases, the derate energy loss dominates over the cooling tower energy loss.
- Case 1, reduced cooling tower availability, produces the largest single year total energy loss, 425,400 MWh, which is about 1.3 times larger than that for Case 0 (331,600 MWh). Of this, unit derates contribute 395,600 MWh, or 95,500 MWh more than Case 0, and cooling tower operation 29,800 MWh, or 1700 MWh less than Case 0. Cooling tower operation for Case 1 is less than that for Case 0 due to the longer duration of Case 1 unit derates (i.e., recall that cooling towers are removed from service for units that are shut down).

Table 13 Worst Year Total Energy Loss for Sensitivity Cases

Case	Year	Cooling Tower Operation		Unit Derates		Total Energy Loss (1000 MWh)
		Approx Hrs of Operation	Energy Loss (1000 MWh)	Approx Hrs of Derate	Energy Loss (1000 MWh)	
0	1993	793	31.5	165	300.1	331.6
1	1993	884	29.8	215	395.6	425.4
2	1993	777	31.0	162	353.0	384.0
3	1993	1177	44.6	189	374.6	419.2
4	1993	849	32.4	162	262.8	295.2
5	1993	793	31.5	165	300.1	331.6
6	1993	826	32.3	184	353.6	385.9
7	1993	804	32.1	165	297.9	330.0
8	1993	802	30.8	165	312.1	342.9
9	1993	946	37.4	172	347.1	384.5
10	1993	888	35.2	115	190.6	225.8
11	1993	1516	59.3	249	290.5	349.8

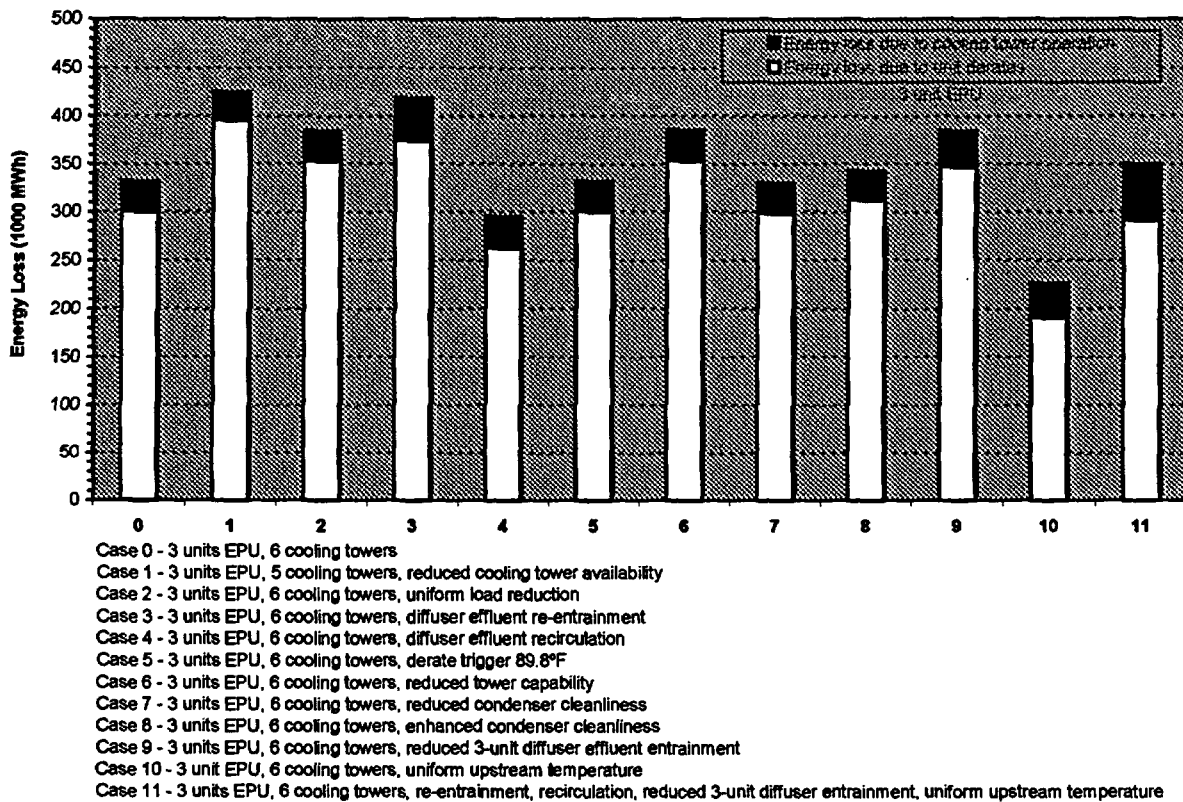

Figure 35. Worst Year Energy Loss for Sensitivity Cases

- Case 11 contains the largest annual number of hours for both unit derates (249 hours) and cooling tower operation (1516 hours), even though the total energy loss for Case 11 is about 18 percent smaller than that for Case 1. The longer duration of cooling tower operation coincides with the fact that the cooling tower energy loss for Case 11 is about 2 times larger than that for Case 1 (59,300 MWh for Case 11 vs. 29,800 MWh for Case 1). The longer duration for unit derates is related to the character of the derates. Case 11 is found to include a larger number of lighter, partial derates, whereas Case 1 is found to include a larger number of derates encompassing total unit shutdowns (again wherein cooling towers are removed from service). The end result is that the energy loss for unit derates is larger for Case 1 than for Case 11 (395,600 MWh for Case 1 vs. 290,500 MWh for Case 11).
- Case by case variations are similar to those identified in Figure 34, and for the most part can be attributed to the same behaviors previously described.

Again, although not summarized in detail herein, almost all of the energy losses for all the sensitivity cases were associated with the NPDES limit for the 24-hour running average instream temperature, 90°F. In two years, 1986 and 1993, energy losses were also associated with the 1-hour running average instream limit of 93°F. In the entire period of record there were no energy losses associated with the 24-hour running average instream temperature rise limit of 10°F.

Considering Case 0 and the various uncertainties represented by the sensitivity cases, cooling tower operation will be required, as found earlier, almost every year, and assuming the annual summertime climate is random and independent, the probability of significant unit derates is estimated between about twenty and thirty five percent in any given year. In the most extreme years, the resulting amount of annual energy loss is expected to fall between about 30,000 MWh and 60,000 MWh for cooling tower operation and between about 190,000 MWh and 400,000 MWh for unit derates. Over many years, the average cooling tower energy loss is expected to fall between about 12,000 MWh and 35,000 MWh per year, and the average unit derates between about 15,000 MWh and 40,000 MWh per year. Over many years, the total combined average cooling tower and derates energy loss is expected to fall between about 30,000 MWh and 75,000 MWh per year.

INDEPENDENT REVIEW

The preceding contents of this report, in draft form, were evaluated in an independent review by Forrest Holley & Associates. The independent review examined the approach, practicality, validity, uncertainty and enhancements, agreement, and overall quality of the study. In general, after receiving additional information from TVA, in response to a list of over forty inquiries, the review judged all the key aspects of the study to be satisfactory. The detailed report submitted by the independent review is given in Appendix A. Corrections and clarifications have been incorporated into this final report in response to the independent review.

OTHER COOLING TOWER SCENARIOS

In addition to the cooling tower arrangement identified as the TVA preferred alternative in the BFN FSEIS of 2002, and based on approval of the modeling methodology by the independent review, other cooling tower scenarios were evaluated. The scenarios and results are given in Table 14. The scenario entitled "CURRENT" represents the present configuration of the cooling towers—that is, Towers 1, 2, 5, and 6 containing original Ecodyne 16-cell cooling towers and Tower 3 containing a newer Balcke-Durr 16-cell cooling tower. CURRENT corresponds to Case 1 of the sensitivity evaluations previously summarized. For Scenarios A through G, the shaded regions of the table highlight the cooling towers that were assumed to be changed from CURRENT. Thus, in Scenario A, Tower 4 is assumed to be restored with a new 16-cell cooling tower (i.e., similar to a Balcke-Durr cooling tower). Scenario B corresponds to Case 0 of the sensitivity evaluations previously summarized, representing the TVA preferred alternative in the BFN FSEIS of 2002 and including a new 20-cell Balcke-Durr cooling tower for Tower 4. Scenario C assumes Tower 4 is restored with a new 16-cell Balcke-Durr-type cooling tower and that the existing Tower 5 is replaced with the same. Note that in this scenario, Tower 5 was chosen randomly without any consideration as to which of the original towers is best suited for replacement. The simulation results would be the same for the replacement of any one of the original Ecodyne towers (i.e., Tower 1, 2, 5, or 6). The same is true for Scenario D, which includes the replacement of two of the original Ecodyne towers with new 16-cell Balcke-Durr-type cooling towers (i.e., as well as restoring Tower 4 with the same). In Scenario E, all the towers are represented by new 16-cell Balcke-Durr-type cooling towers (i.e., restoring Tower 4 and replacing all of the existing Ecodyne towers). In Scenario F, Towers 1, 2, 4, and 5 are represented by new 20-cell cooling towers and Towers 3 and 6 by new 16-cell cooling towers (i.e., again restoring Tower 4 and replacing all of the existing Ecodyne towers). Scenario F represents the expected largest number of cooling tower cells that can be constructed in the tower field without significant modifications to the site. Scenario G assumes that cooling towers are nonexistent for both Tower 4 and Tower 5. This scenario is provided to examine the potential

impact of the situation wherein Tower 4 is not restored and another tower becomes unavailable for service.

The results in Table 14 focus on the estimated energy loss due solely to unit derates, since this is the primary factor dictating the potential need for enhancing the cooling system. Provided are computed ranges for the frequency of significant derate events, the amount of derate energy loss in the worst year of the simulation (1993), and the average derate per year for the entire simulation (i.e., 20 years). The ranges are based on sensitivity runs represented by Cases 2 through 11 in Table 10. The cooling towers are assumed to be reliable in each scenario (i.e., Case 1 of the sensitivity runs is excluded). The middle number of the range corresponds to the baseline conditions given in Table 8, except for assumption No. 15, which applies only to the baseline cooling tower arrangement (i.e., Case 0). That is, for each scenario, the sensitivity runs all use the cooling tower arrangement that defines the scenario.

Note that all simulations in Table 14, and throughout this report, are for the three BFN units operating at extended power uprate (120 percent of original power level). By restoring and/or replacing towers, Scenario CURRENT through Scenario F sequentially provide additional cooling to the plant CCW system. Thus, in moving down in Table 14, the frequency of derate events and magnitude of derate energy losses tend to decrease (i.e., except for Scenario G, of course). Overall, the following specific observations are emphasized.

- For the CURRENT cooling tower arrangement the probability of significant unit derates is between about twenty five percent and seventy percent in any given year, assuming the annual summertime climate is random and independent. In extreme years, the annual derate energy loss would be expected to fall between about 320,000 MWh and 530,000 MWh. Over many years, the average derate energy loss would be expected to fall between about 30,000 MWh and 110,000 MWh per year.
- If a cooling tower becomes unavailable in the current configuration, creating the Scenario G situation, the probability of significant unit derates increases to between about thirty percent and ninety percent in any given year. In extreme years, the annual derate energy loss would be expected to fall between about 395,000 MWh and 870,000 MWh. Over many years, the average derate energy loss would be expected to fall between about 45,000 MWh and 230,000 MWh per year.

Table 14. Derate Energy Loss for BFN Cooling Tower Scenarios

Scenario	Units ⁽¹⁾			Cooling Towers ⁽²⁾						Derate Energy Loss ⁽³⁾		
	1	2	3	1	2	3	4	5	6	Frequency of Significant Derate Events ⁽⁴⁾	Worst Year - 1993	Avg per Yr
											(1000 MWh)	(1000 MWh)
CURRENT (Case 1)	120	120	120	ED16	ED16	BD16	None	ED16	ED16	5/20 - 5/20 - 14/20	320 - 404 - 527	30 - 31 - 110
A	120	120	120	ED16	ED16	BD16	BD16	ED16	ED16	4/20 - 4/20 - 8/20	219 - 325 - 408	17 - 21 - 51
B (Case 0)	120	120	120	ED16	ED16	BD16	BD20	ED16	ED16	4/20 - 4/20 - 7/20	191 - 300 - 375	15 - 19 - 40
C	120	120	120	ED16	ED16	BD16	BD16	BD16	ED16	4/20 - 4/20 - 7/20	173 - 308 - 398	13 - 19 - 37
D	120	120	120	ED16	ED16	BD16	BD16	BD16	BD16	4/20 - 4/20 - 7/20	135 - 291 - 324	10 - 17 - 26
E	120	120	120	BD16	BD16	BD16	BD16	BD16	BD16	3/20 - 3/20 - 5/20	119 - 216 - 253	8 - 13 - 16
F	120	120	120	BD20	BD20	BD16	BD20	BD20	BD16	1/20 - 2/20 - 2/20	36 - 108 - 198	2 - 7 - 12
G	120	120	120	ED16	ED16	BD16	None	None	ED16	6/20 - 6/20 - 18/20	395 - 469 - 873	45 - 50 - 232

- Notes: (1) Percent of unit original power level.
 (2) ED=Ecodyne tower, BD=Balcke-Durr tower, 16=16 cells, 20=20 cells.
 (3) Ranges based on sensitivity runs excluding Case 1 conditions (reduced cooling tower availability). Middle number is for baseline assumptions as specified in Table 8, except assumption No. 15. That is, all runs use the cooling tower arrangement as specified for each scenario, not the cooling tower arrangement specified by baseline assumption No. 15 in Table 8 (except Scenario B, of course).
 (4) Years with derates ≥ 3840 MWh (1 unit shutdown for 3 hours).

- For Scenario B, the TVA preferred alternative identified in the BFN SEIS of 2002, the probability of significant unit derates is estimated between about twenty percent and thirty five percent in any given year. In extreme years, the annual derate energy loss would be expected to fall between about 190,000 MWh and 375,000 MWh. Over many years, the average derate energy loss would be expected to fall between about 15,000 MWh and 40,000 MWh per year.
- Scenario C, which includes two new 16-cell cooling towers, provides about the same amount of expected energy loss as Scenario B, the BFN SEIS preferred alternative with one new 20-cell tower. For example, the probability of significant unit derates is the same, between about twenty percent and thirty five percent in any given year. In extreme years, the annual derate energy loss includes only a slightly wider range, between about 170 MWh and 400,000 MWh (vs. 190,000 MWh and 375,000 MWh for Scenario C). Over many years, the average derate energy loss is also about the same, between about 10,000 MWh and 40,000 MWh per year.
- Scenario E, which basically provides six new 16-cell cooling towers, as in the original BFN cooling tower arrangement, reduces the probability of significant unit derates to between about fifteen percent and twenty five percent in any given year. In extreme years, the annual derate energy loss would be expected to fall between about 120,000 MWh and 250,000 MWh, and over many years, the average derate energy loss would be expected to fall between about 10,000 MWh and 20,000 MWh per year.
- Scenario F, of course, provides the greatest cooling of all the scenarios. The probability of significant unit derates is between only about five percent and ten percent in any given year. In extreme years, the annual derate energy loss would be expected to fall between about 40,000 MWh and 200,000 MWh, and over many years, the average derate energy loss would be expected to fall between about 2,000 MWh and 15,000 MWh per year.

CONCLUSIONS

In this study, the impact of BFN operation on river temperatures regulated by the site NPDES permit has been evaluated using a hydrothermal model of the plant. The objective of the study was to estimate the potential ranges of energy loss associated with cooling tower operation and plant derates. The following conclusions are provided based on the information and results presented herein.

Modeling Approach

- The BFN hydrothermal model is considered suitable for evaluating the impact of the plant condenser cooling water on the NPDES river temperatures. An independent review of the study found the modeling approach to be appropriate, adequate, and properly implemented to satisfy the primary purpose of the study. The review also found the major processes and factors included in the model to be valid and the results practical and reasonable.
- As such, the hydrothermal model is considered suitable for estimating the potential ranges of energy loss associated with cooling tower operation and unit derates. In turn, this information is considered suitable, as may be needed, for making key decisions regarding the design, operation, and maintenance of the plant condenser cooling water system.

Key Results

- Inherent uncertainties in the model formulation, data, and assumptions dictate that the model results be provided in terms of ranges of energy loss. In this study, the ranges were determined by sensitivity simulations encompassing changes in key parameters representing the model formulation, data, and assumptions.
- The parameter of primary interest in terms of decisions regarding upgrades to the cooling system is the loss of energy in unit derates. These are summarized in Table 14.
- For the current arrangement of cooling towers, containing four original 16-cell Ecodyne towers and one newer 16-cell Balcke-Durr tower, and assuming the cooling towers are reliable, the following is found for three units at 120 EPU (scenario CURRENT in Table 14):
 - On the average, significant unit derates are likely to occur about once every 1 to 4 years. Individual derate events could include the shutdown of all three units.
 - In extreme years, the annual derate energy loss is expected to fall between about 320,000 MWh and 530,000 MWh.
 - The average derate energy loss is expected to fall between about 30,000 MWh and 110,000 MWh per year.

- For the arrangement of cooling towers identified as the TVA preferred alternative in the 2002 FSEIS for BFN operating license renewal, containing four original 16-cell Ecodyne towers, one newer 16-cell Balcke-Durr tower, and one new 20-cell Balcke-Durr-type tower, and assuming the cooling towers are reliable, the following is found for three units at 120 percent EPU (Scenario B in Table 14):
 - On the average, significant unit derates are likely to occur about once every 3 to 5 years. Individual derate events could include the shutdown of all three units.
 - In extreme years, the annual derate energy loss is expected to fall between about 191,000 MWh and 375,000 MWh.
 - The average derate energy loss is expected to fall between about 15,000 MWh and 40,000 MWh per year.
- A cooling tower arrangement containing three original 16-cell Ecodyne towers and three new 16-cell Balcke-Durr-type towers (Scenario C in Table 14) will provide about the same expected frequency and potential range of average annual derate energy loss as the TVA preferred alternative in the 2002 FSEIS (for three units at 120 percent EPU). For a single extreme year, however, this arrangement yields a slightly higher potential amount of derate energy loss (e.g., about 6 percent more than the 2002 FSEIS preferred alternative).
- For three units at 120 percent EPU, the frequency of significant unit derates can be reduced to about once every 10 years by a cooling tower arrangement containing four new 20-cell Balcke-Durr-type towers and two new 16-cell Balcke-Durr-type towers (Scenario F in Table 14).

Other General Observations

- None of cooling tower arrangements considered in this study eliminate the potential occurrence of unit derates. As such, procedures should be developed to help TVA effectively manage derates, when they occur.
- The hydrothermal model simulations are based on a 20-year period from 1985 to 2004. This period includes the warmest year of “record”, 1993 (based on temperatures from 1948 to 2004 in Chattanooga, 57 years total). In all the model simulations summarized herein, 1993 consistently produces the worst case year for unit derates, often exceeding the second-worst year by a factor of at least three. That is, 1993 dominates the model results for the estimated unit derates. Although conditions as extreme as 1993 have occurred only once in the past 57 years, it cannot be assumed that the same will not occur again over the next 30 years of

operation at BFN. At this time, since there is no acceptable method to reliably forecast years of extreme summertime meteorology, the potential impact of a year such as 1993 cannot be dismissed in model results. Even in the absence of 1993, the temperature records show three other years (1952, 1954, and 1977) that were yet hotter than the second-warmest year in the 20-year simulation period (1986).

- Almost all the energy losses reported herein are associated with the NPDES limit for the 24-hour running average downstream temperature, 90°F. Although minor by comparison, energy losses also occurred due to the 1-hour running average downstream limit of 93°F. In all the simulations there were no energy losses associated with the 24-hour running average instream temperature rise limit of 10°F. In general, the instream temperature rise becomes large during low flow events in the winter and spring. Even though the model does not foresee problems with the temperature rise, observations with the operation of only two units have recorded events where the temperature rise has exceeded 8°F. Since the hydrothermal model was calibrated primarily for summer conditions, and due to uncertainties associated with the local hydrodynamic behavior of the river in low flow events, the potential occurrence of events threatening the limit for instream temperature rise is yet considered significant. Under these conditions, TVA should consider developing procedures for using cooling towers under winter or spring operating conditions, at least for one unit.
- The model results summarized herein assume a trigger point for cooling tower operation of 89°F (24-hour average downstream temperature). The plant currently does not consider cooling tower operation until the temperature reaches 89.5°F. “Early” implementation of cooling towers may reduce derate energy losses, as witnessed by some of the results presented herein. However, this is true only if the unit derate occurs within 24 hours of startup of the cooling towers. That is, for NPDES limits based on a 24-hour average, the computed compliance parameters have “memory” only of the temperatures measured in the previous 24 hours. Thus, downstream temperatures “cooled” by tower operation earlier than 24 hours before a derate have no impact on the computed 24-hour compliance temperature. However, in practice, it is best to have cooling towers in service well before 24 hours of a potential derate, to ensure that tower equipment is working at peak efficiency, and to ensure that the downstream temperature is as cool as possible when entering the 24-hour window before a potential unit derate.

Model Improvements

- Perhaps the greatest sources of uncertainty in the hydrothermal model are estimates for the upstream ambient river temperature and the overall behavior of the plant intake withdrawal zone and diffuser mixing zone. Most of this uncertainty likely is associated with complex, three-dimensional interactions among different regions of the flow that cannot reasonably be represented by the algorithms contained in the current hydrothermal model, particularly at low river discharges. Although three-dimensional models are available to examine these interactions, implementation of these in the hydrothermal model presently is infeasible, due to the extreme computational effort required. However, as emphasized by the independent review, much can still be learned from these models as to the behavior of the flow in the immediate vicinity of BFN. As such, in a separate project, TVA currently is investigating a reservoir-wide, three-dimensional model to help forecast the impact on the upstream ambient temperature by such factors as stratification, main channel-overbank diversity, and river flow.
- As emphasized by the independent review, a flow model containing greater resolution in space and time could perhaps improve predictions of reverse river flow in the vicinity of BFN (compared to the current MacCormack model). This enhancement likely could be made with a low level of effort.
- From the standpoint of the plant, significant sources of uncertainty in the hydrothermal model are associated with the cooling towers—in particular, the cooling tower performance (e.g., capability) and plant water routing, especially when helper-mode operation requires sluicing at Gate Structure 1A to bypass a portion of the CCW flow directly to the diffusers. To reduce uncertainty, the plant should consider occasionally collecting simple measurements of water level, flow, and temperature at key locations in the CCW system during cooling tower operation. In practice, forecast uncertainty can further be reduced by enhanced monitoring of the actual operating conditions of the towers (i.e., the exact towers, pumps, and fans in service).

REFERENCES

ADEM, NPDES Permit No. AL002208 for Tennessee Valley Authority Brown's Ferry Nuclear Plant, Outfall DSN001, State of Alabama, Alabama Department of Environmental Management, September 29, 2000.

Bender, Merlynn D., Gary E. Hauser, Ming C. Shiao, and William D. Proctor, "BETTER: A Two-Dimensional Reservoir Water Quality Model, Technical Reference Manual and User's Guide," TVA Engineering Laboratory, Report No. WR28-2-590-152, Norris, Tennessee, 1990.

Benton, Dudley, "Development of a Two-Dimensional Plume Model," Dynamic Solutions, LLC, Knoxville, Tennessee, May 2003.

Benton, Dudley, Charles Bowman, Mark Hydeman, and Paul Miller, "An Improved Cooling Tower Algorithm for the CoolTools™ Simulation Model," ASHRAE, Atlanta, GA. AC-02-9-04, January 2002.

Chaudry, M. H., *Applied Hydraulic Transients*, 2nd Edition, Van Nostrand Reinhold Company: New York, 1987.

Cooling Tower Test Associates, Inc (CTTA), File No. F98-23-1, F98-23-2, August 1998.

Ferrick, M. G., and W. R. Waldrop, "Two Techniques for Flow Routing with Application to Wheeler Reservoir," Report No. 3-519, TVA Division of Water Management, Water Systems Development Branch, Norris, Tennessee, 1977.

Fischer, H. B., E. J. List, R. C. Y. Yoh, J. Imberger, and N. H. Brooks, *Mixing in Inland and Coastal Waters*, Academic Press: New York, 1979.

Fletcher, C. A. J., *Computational Techniques for Fluid Dynamics. Volume 2 Specific Techniques for Different Flow Categories*, 2nd Edition, Springer-Verlag, New York, 1991.

Harleman Donald R. F., Lawrence C. Hall, and T. Gray Curtis, "Thermal Diffusion Of Condenser Water in a River During Steady and Unsteady Flows," Report No. 111, Hydrodynamics Laboratory, Department of Civil Engineering, Massachusetts Institute of Technology, September 1968.

Hopping, Paul N., and Brennan T. Smith, "Measurement of Flow Patterns Using GPS Drogues," Proceedings of the Specialty Conference, Hydraulic Measurement and Experimental Methods, ASCE, July 2002.

Lin, Fangbiao, and George E. Hecker, "3-D Numerical Modeling of Thermal Discharge from Browns Ferry Nuclear Plant," Report submitted to the Tennessee Valley Authority, Alden Research Laboratory, Inc., June 2002.

MacCormack, R. W., *Effect of Viscosity in High Impact Cratering*, AIAA Paper 69-354, 1969.

McIntosh, D. A., B. E. Johnson, and E. B. Speaks, "Validation of Computerized Thermal Compliance and Plume Development at Sequoyah Nuclear Plant," TVA Engineering Laboratory, Report No. WR28-1-45-115, Norris, Tennessee, 1983.

Shiao, Ming C., Merlynn D. Bender, and Gary E. Hauser, "Two-Dimensional Water Quality Modeling of Wheeler Reservoir," TVA Engineering Laboratory, Report No. WR28-1-3-105, Norris, Tennessee, June 1993.

Stolzenbach, Keith D., "Estimation of Water Temperature Increases in Wheeler Reservoir Caused by the Discharge of Heated Water from Browns Ferry Nuclear Plant During Open Cycle Operation", February 1975.

TVA, *Browns Ferry Nuclear Plant Final Safety Analysis Report*, Section 11.6 Condenser Circulating Water System and Section 12.2.7 Condenser Cooling Water System, Amendment 20, Tennessee Valley Authority, September 2003.

TVA, "Prediction and Control of Water Temperatures in Wheeler Reservoir during Operation of the Browns Ferry Nuclear Plant," Advance Report No. 14, Tennessee Valley Authority, Division of Water Control Planning, Engineering Laboratory, April 1972.

TVA, "Final Supplemental Environmental Impact Statement for Operating License Renewal of the Browns Ferry Nuclear Plant in Athens, Alabama", Tennessee Valley Authority, March 2002. (This document is available at <http://www.tva.gov/environment/reports/brownsferry/index.htm>.)

Vigander, S., Rex A. Elder, and Norman H. Brooks, "Internal Hydraulics of Thermal Discharge Diffusers," ASCE Journal of Hydraulics Division, February 1970.

APPENDIX A

Independent Review Report by Forrest M. Holly, Jr. P.E.

Notes:

- 1. The following independent review was conducted for a draft version of the subject report, dated February 28, 2005. Many of the comments provided by the independent review have been incorporated in the final report.**
- 2. Specific inquiries provided by the independent reviewer refer to specific page numbers, paragraphs, and lines in the draft report. Due to subsequent revisions, the content and location of these specific references have changed in the final report. In general, however, the inquiry provided by the independent reviewer and the response provided by TVA are "self contained." That is, in most cases, the issue of concern can be understood by the question and answer provided in the independent review report. In cases where additional clarification is needed, the appropriate area of discussion can be found in the final report, albeit at perhaps a different location than in the draft report.**
- 3. In the time since the independent review, additional information has been provided related to Question No 1. The FSAR for BFN currently restricts closed-mode operation due to the requirements for seismic qualification of temperature monitors at the exit of each cooling tower. This monitoring is required to protect the tech spec temperature limits at the plant intake pumping station for the Residual Heat Removal Service Water (RHRSW) and the Emergency Equipment Service Water (EECW).**

Independent Review

**“Hydrothermal Modeling of Browns Ferry Nuclear Plant with
Units 1, 2, and 3”**

WR2005-1-67-135, February 2005

by Paul N. Hopping, Walter L. Harper, and Brennan T. Smith,

TVA / Browns Ferry Nuclear Plant Purchase Order 00043718

Forrest M. Holly Jr., P.E.
Forrest Holly & Associates
2010 Ridgeway Dr
Iowa City, IA 52245
22 March 2005



F. M. Holly Jr.

2 April 2005

Practicing in the State of Alabama under Interim Permit No. IP-05-49

I. Background

This report comprises the response to TVA / Browns Ferry Nuclear Plant Purchase Order 00043718, dated 10 February 2005, with regard to an independent review of the draft report "Hydrothermal Modeling of Browns Ferry Nuclear Plant with Units 1, 2, and 3", by Paul N. Hopping, Walter L. Harper, and Brennan T. Smith, WR2005-1-67-135, February 2005.

The background of the study and expectations of the independent review are clearly stated in the following extracts from the Scope of Work in the Purchase Order:

"TVA presently is completing an internal study to estimate the impact of river flow and water temperature on the operation of the Browns Ferry Nuclear Plant (BFN), located on the Tennessee River (Wheeler Reservoir) in northern Alabama. Although the plant has three nuclear units, only two currently are in service. The third unit is being refurbished and is expected to be returned to service before the end of 2006. Furthermore, all three units are being uprated to 120 percent of their original licensed power.

"The primary objective of the TVA study is to estimate, for three unit operation at extended power uprate (EPU), the potential range of energy reductions associated with requirements to maintain compliance with the plant National Pollutant Discharge Elimination System (NPDES) permit. The energy reductions occur as a result of the operation of cooling towers and the operation of units at reduced load (derates) to prevent exceedances of the NPDES instream water temperature limits. The predicted energy reductions will be used to determine the expected generation for the plant.

"In the study, a hydrothermal model is being used to estimate energy reductions by simulating the operation of the plant for a period of time encompassing a range of river and meteorological conditions. The period chosen for the study includes seven years, 1987 through 1994. The hourly upstream (ambient) river temperatures for the plant are determined using a water quality model for Wheeler Reservoir. A hydrothermal model for BFN is then used to determine the hourly river temperatures at the downstream end of the plant diffuser mixing zone. The BFN model includes modules to estimate the river flow at the plant, the plant intake temperature (withdrawal zone), the temperature rise across the plant condensers (plant performance), the cooling tower discharge temperatures (cooling tower performance). Specific procedures are included in the model to decide the appropriate mode of operation for each unit (open vs. helper), the process for placing cooling towers in and out of service, and the process for derating and returning the units to full power. A tracking module is used to accrue the amount of net energy reduction incurred by station service for tower

operation and unit derates, as required to maintain compliance with the NPDES permit.

“TVA is interested in having an independent review of this internal study to determine if the results are reasonable and appropriate for TVA to use as part of their power planning assumptions. The independent review will include evaluating the approach and assumptions used in developing the model and the output and interpretations developed from the modeling effort.

...

“In general, the independent review should consider the following aspects of the TVA study:

“Approach: Are the overall methods used to perform the study appropriate, adequate and properly implemented to satisfy the primary objective of the study?

“Practicality: Based on the approach taken and the basic information provided, do the results of the study seem reasonable? Based on changes in assumptions and/or input parameters, are the resulting changes in model results in line with expectations (i.e. for sensitivity evaluations)?

“Validity: Do the assumptions appear valid? Are there other factors that perhaps should have been included in the calculations? For example, do independent spot checks indicate that a significant source/sink, diffusion, or dissipation process has been neglected or improperly estimated?

“Uncertainty and Enhancements: Are there significant sources of uncertainty not recognized in the study? What enhancements in the methods of analysis can be used confidently to reduce these sources of uncertainty? What resources and what level of effort would potentially be required to implement these enhancements?

“Agreement: Does the independent reviewer agree with the basic conclusions of the study? If not, why not? What different or additional conclusions, if any, are recognized by the independent reviewer?

“Overall Quality: Does the overall quality of the study appear to be in line with professional standards for this type of analysis?

II. Review Response

The reviewer received the draft report electronically on 28 February 2005, and subsequently received background references and materials in hardcopy and on CD-ROM. The draft report included neither Executive Summary nor Conclusions. The reviewer sent a list of 45 technical questions to the report authors on 11 March. These questions requested clarification of certain technical details on the plant operation, modeling approach, and report presentations. TVA personnel provided answers to the questions on 15 and 17 March, along with some additional references on CD-ROM. The reviewer's questions and the TVA responses are included as Appendix A of this report.

The review responses below respond directly to the itemized terms of reference of the Scope of Work above.

II.1 *Approach: Are the overall methods used to perform the study appropriate, adequate and properly implemented to satisfy the primary objective of the study?*

Yes. There are various suggestions and items of detail that are mentioned in subsequent sections, but overall the methods used were appropriate, adequate, and properly implemented within the limits of available historical data for calibration and validation. The questions in Appendix A, and the TVA responses to them, dealt largely with the details of the modeling approach and implementation of the model. The reviewer was largely satisfied with the responses to the questions, so they are not dealt with further in the body of this report. TVA may wish to add some clarifications to the report based on the responses to the questions.

Some additional questions and comments on methodology and implementation are as follows:

II.1.1 It would be very useful for this clarification on the relation between tower flowrates and capabilities, see Question 18, to appear in the text.

II.1.2 Apparently the mixing zone model was put together by TVA on the basis of published jet and plume formulations in the literature. It would be helpful to provide more complete referencing of the various sources of the self-similar plume formulations, though they appear to be conventional for this type of modeling.

II.1.3 The rather poor agreement between the measured and computed downstream temperatures from days 206 to 218 in 2002, Figure 23, should be commented on in the text. Something else must have been going on.

II.1.4 In Tables 6 and 7, only some years are shown. Why is this?

II.1.5 Figure 27 seems to suggest that the model predicted an apparent NPDES permit violation on 26-27 July of 1993 – yet in the model the units were shut down. There is

still a small heat load added to the river, as the temperature increment is a few tenths of a degree above zero. It would be helpful if the report included an explanation of this behavior – is it simply related to the 24-hour averaging implicit in the presented data? Is there a plant service heat load that exists even when the units are shut down?

II.1.6 In the response to Question 44 of Appendix A, TVA pointed out that the term “dilution” is defined by temperature differences, rather than volumetric mixing, in accordance with traditional TVA practice. It would be worthwhile to include this clarification in the text.

II.2 *Practicality: Based on the approach taken and the basic information provided, do the results of the study seem reasonable? Based on changes in assumptions and/or input parameters, are the resulting changes in model results in line with expectations (i.e. for sensitivity evaluations)?*

The results of the study appear reasonable and practical. The reviewer has spot-checked the magnitudes of energy losses to tower operation and unit derates, and found the magnitudes, expressed as average number of towers in use and average number of units derated when actions are taken, to be reasonable.

The report authors go to some length to explain the counterintuitive responses to diffuser effluent recirculation, modified condenser efficiency, and uniform (warmer) upstream temperature, Cases 4, 7, 8, and 10. This reviewer finds the arguments to be compelling, and suggestive of the need to use the model and other resources to see if more elaborate trigger mechanisms for tower operation can be developed to delay and/or reduce the depth of unit derates. Such mechanisms might well need to be based on more effective ambient and intake temperature forecasting than is available at present. The middle paragraph of page 75 speaks to this point.

Case 5, reduction of the tower trigger level from 90.0 to 89.8 degrees, seems not to have yielded any useful information – and such a small change in trigger level is well within the error and uncertainty of in-stream temperature measurements.

As the report authors themselves recognized, it is probably unrealistic to expect the units to “see-saw” as they say in response to the input from the derating module. Therefore for all other things being equal, the energy losses predicted by the model would likely be greater for real situations, in which a unit would likely be kept shut down until it was clearly going to be possible to bring it back on line with some assurance of continuous operation. Perhaps the plant performance module could be enhanced to better reflect this reality, though reality would surely have to take into account the hydrological and meteorological forecasts over the next few days, something not presently included in the model.

II.3 *Validity: Do the assumptions appear valid? Are there other factors that perhaps should have been included in the calculations? For example, do independent spot*

checks indicate that a significant source/sink, diffusion, or dissipation process has been neglected or improperly estimated?

The assumptions appear to be valid in general, and several of the questions and responses in Appendix A dealt them. The reviewer is satisfied with those responses.

The neglect of surface heat exchange over the distances and times involved is reasonable based on the reviewer's experience in other rivers. It is also reasonable not to have included the CCW outflow canal and gate hydraulics in the model, since their effects are implicitly reflected in the condenser performance curves for helper-mode operation. The background on, and justification for, the river flow model used to obtain the flowrates at Chatanooga for the bias assessment of Figure 9 is weak. But assuming that this model respected overall mass conservation, its results were surely adequate for the purposes they were used in determining the validity of the proposed period of record for the model simulations.

Two issues not dealt with in Appendix A are as follows:

II.3.1 Figure 29 has some strange kinks in the condenser curves that do not appear to be reflected in Figure 16. These are not the same presentation, but it would be helpful if the authors could explain the anomalies in the curves, if in fact they are anomalies.

II.3.2 The response to Question 11, regarding Figure 11 and the effects of ROS releases on upstream river temperatures at the hourly scale, should be included in the report.

II.4 *Uncertainty and Enhancements: Are there significant sources of uncertainty not recognized in the study? What enhancements in the methods of analysis can be used confidently to reduce these sources of uncertainty? What resources and what level of effort would potentially be required to implement these enhancements?*

TVA has done an admirable job trying to capture the effects of major uncertainties, in particular regarding temperatures in the withdrawal zone and mixing-zone dynamics. Still, these are obvious major sources of uncertainty, and the sensitivity analyses show that the overall study conclusions regarding energy loss are strongly affected by this uncertainty. This reviewer agrees with the strategy of performing sensitivity tests based on simplified alternative assumptions rather than trying to refine the characterization of the mixing and withdrawal zones, since even a far more elaborate treatment would still be subject to considerable uncertainty.

Some specific additional observations are as follows:

II.4.1 Use of a TR flow model with much smaller spatial increments, for example one mile or less, could bring more resolution, in space and time, to reversing flow in the vicinity of BFN. This may require a shift to an implicit one-dimensional model,

sacrificing the experience and calibration gained with the existing model. But there are many software products available for this purpose, and TVA could develop a replacement model with a relatively low level of effort, possibly with the support of engineering interns, for eventual incorporation in the hydrothermal model. Still, one should not expect this improvement to provide any dramatic reduction in uncertainty in model results.

II.4.2 Although the use of the '85 to '04 period of data for actual plant operation is well justified and logical, one can still wonder if a longer period of record, or a synthetic record, might have led to some reduction in the uncertainty of the results. Uncertainty in parameters such as the expected risk of tower operation or derates in a given year, and the magnitude of energy loss, could perhaps be reduced by using a much longer period of record, perhaps necessarily synthetic and without the benefit of actual Station 4 ambient temperatures. Thus it could require use of an upstream temperature forecast model such as BETTER or equivalent, with its own contribution of uncertainty.

II.4.3 Along with the ambient temperature, the mixing- and withdrawal-zone dynamics, and interaction between them with complex recirculating river flows, is probably the greatest source of uncertainty in the hydrothermal model. It is rapidly becoming feasible to build detailed three-dimensional, steady-state models of such situations including buoyancy effects. For example, the details of a Mississippi River diffuser and its individual nozzles, one mile of channel upstream, and three miles of channel downstream were recently modeled by IIHR Hydroscience & Engineering as part of a study of thermal impacts on downstream mussel beds. Such models can be provided by many organizations, but still require a high level of modeler expertise, and require the order of days to compute one steady state. But they require no self-similar jet/plume models or macroscopic assumptions about recirculation and jet self-entrainment. The results of such a modeling effort could provide valuable input to parameterized or other heuristic models, perhaps using neural-network techniques, to reduce the uncertainty of the hydrothermal model. Such an effort would be significant, requiring the order of \$100,000 and one or two years of time. But it could play a valuable future role in reducing the uncertainty of the hydrothermal model, which is basically sound in its other procedures.

II.4.4 Although the issue of climate change is clearly a difficult one and does not readily lead to rational assumptions of future ambient and atmospheric temperatures, it would have been useful for this study to have at least quantified the sensitivity of energy loss to unit climate changes in the future. For example, two additional alternate cases with the record of wet-bulb temperatures one degree above and one degree below the historical values might have given some sense of sensitivity to this possible change, through changed cooling-tower performance. Of course one could make the same argument for studying sensitivity to river temperatures as affected by climate change, but as the report authors clearly point out, dilution effects tend to mollify sensitivity to ambient temperatures so this is less important.

II.4.5 The reviewer is troubled, as the report authors apparently were, by the lack of any intuitive physical justification for the apparent dependence on mixing-zone entrainment coefficients on the number of diffusers in operation. This issue could be obviated by an ambitious three-dimensional modeling study as described in II.4.3 above, but in the meantime the report seems to deal with this issue as well as can be expected given the available data.

II.4.6 Regarding Case 1, reduced cooling-tower availability, unavailability of Tower 4 was studied since it is not yet reconstructed. But it would also be useful to study a subset of this Case, reflecting the realistic situation of random tower unavailability from among a normally-available set. The statistics of this random process could be based on an analysis of actual tower reliability in the historical record.

II.5 *Agreement: Does the independent reviewer agree with the basic conclusions of the study? If not, why not? What different or additional conclusions, if any, are recognized by the independent reviewer?*

The reviewer agrees with the basic conclusions of the study, and his spot checks of various quantitative results support the conclusions.

As pointed out in section II.2 above, a possible additional conclusion of the study is that there may be promise in optimal use and timing of cooling tower operation to delay and minimize the magnitude of unit derates.

II.6 *Overall Quality: Does the overall quality of the study appear to be in line with professional standards for this type of analysis?*

The overall quality of the study is very much in line with professional standards for this kind of analysis. The report is very clearly written, and provides thoughtful discussion and background in interpreting model results. The responses to the reviewers questions in Appendix A were particularly clear and articulate.

The questions and responses in Appendix A may lead the report authors to add some explanations and perhaps clarify others. In addition, Appendix B contains a few miscellaneous typographical errors that the reviewer noted in perusing the report.

II.7 Other Suggestions

A few additional observations are as follows:

II.7.1 The Case 0 results as depicted in Figure 25 are not consistent with Table 9 from which they were drawn. However these same results as depicted in Figures 31, 32, and 33 appear to be correct.

II.7.2 In Figures 26 and 27, one can infer when towers were in operation by the changes in the temperature rise. Nonetheless, it would be interesting to show tower operation directly, as the text refers to the timing of tower operation as well as unit derates. This would add one panel to the Figures, but it would make the Figures even more complete and informative.

II.7.3 On page 58, last line, I believe the figure should be 31,000, not 32,000 MWh.

II.7.4 In Table 9, it is not clear to the reviewer what “hours” means for cooling-tower operation – are they tower-hours, or calendar hours? A check of the order of the magnitude of the energy losses suggests that when towers are in operation, there are 4-5 of them running, suggesting that the hours are indeed calendar hours. Perhaps this could be clarified in the final report.

III. Recommendations

The reviewer's recommendations are captured for the most part in the responses to the specific charges above.

One additional recommendation concerns intake temperatures. It is the reviewer's understanding that there are no direct temperature measurements in the CCW intakes themselves. It would seem to be very useful to have such measurements for comparison with Station 4, Station 14, and Station 1 temperature data, especially in support of any future attempt to better understand the interaction between the withdrawal and mixing zones through detailed modeling.

It has been the reviewer's experience that hydrothermal modeling of powerplant cooling systems provides valuable quantitative data and sensitivity to uncertain parameters. But of even more importance is that such modeling leads modelers and operators alike to better understand the subtle interactions of the various elements of the cooling systems themselves, and to deepen their intuition as to cause and effect that arises from their interactions with and contemplation of model results. The BFN hydrothermal model surely has played this role while providing valuable quantitative data on expected energy losses associated with permit compliance.

Appendix A

Technical Questions on BFN Report WR2005-1-67-135

Forrest Holly
11 March 2005

(These questions may have ready answers in the text itself or in the references provided. Please point me to the answers or provide an answer in this document below the question)

1. Page 11, end of first paragraph. Just out of curiosity, why is closed-mode operation not possible?

Perhaps the most significant reason the plant cannot operate in closed-mode, at least in the summer, is because the cooling towers are under-designed relative to specification requirements associated with the plant intake temperature. Currently, to maintain compliance with requirements for Residual Heat Removal Service Water, BFN must start reducing reactor thermal power when the intake temperature reaches 92.5°F. The maximum allowable Ultimate Heat Sink (UHS) temperature for Emergency Equipment Cooling Water (EECW) is 95.0°F, at which point the plant must be shut down. The original cooling towers cannot meet these limits, at least with all three units running (e.g. see Table 8, assumption No. 26). Also, the cooling tower lift pumps do not have enough capacity to balance closed-mode operation for three units with 3 CCW pumps per unit (and perhaps also the warm- and cold-water channels). The original concept was to reduce the CCW flow to 2 pumps per unit when a unit was placed on towers, but this will create other problems related to excess turbine backpressure.

2. Page 11, third bullet. I assume that the ? T compliance calculation is made using the upstream and downstream measured temps at the same time, with no attempt to account for travel time, right?

Correct.

3. Page 11, last sentence. I take this to imply that for ambient temp above 90, the plant must essentially be derated to the cooling-tower thermal capacity, right?

If river conditions are such that it is unable to assimilate any waste heat without exceeding the 90°F downstream limit, the plant would have to be derated to a point where the cooling tower discharge temperature is no greater than 90°F. A situation could arise where the ambient temperature at the 5-foot depth is 90°F, but cooler bottom water yet allows the river to assimilate part of the plant waste heat without exceeding the 90°F downstream limit.

4. Page 12, line 4. Why is station 14 not used routinely as the intake/ambient temperature monitor?

The reason Station 4 is specified in the NPDES permit as the primary upstream monitor, rather than Station 14, currently is hidden deep in TVA files. The original upstream temperature station was located at TRM 309.7, 11.9 miles further upstream than the existing Station 4. The present arrangement was implemented in early 1975 to "minimize natural temperature variations." References convenient to us do not explain the rationale for choosing Station 4 as primary and Station 14 as backup. In general, the difference between the Station 4 temperature and Station 14 temperature is slight. Below is an example comparison of the hourly temperature at the 5-foot depth for 1993. Please let us know if this is an important issue—if desired, we can retrieve TVA files from that "era."

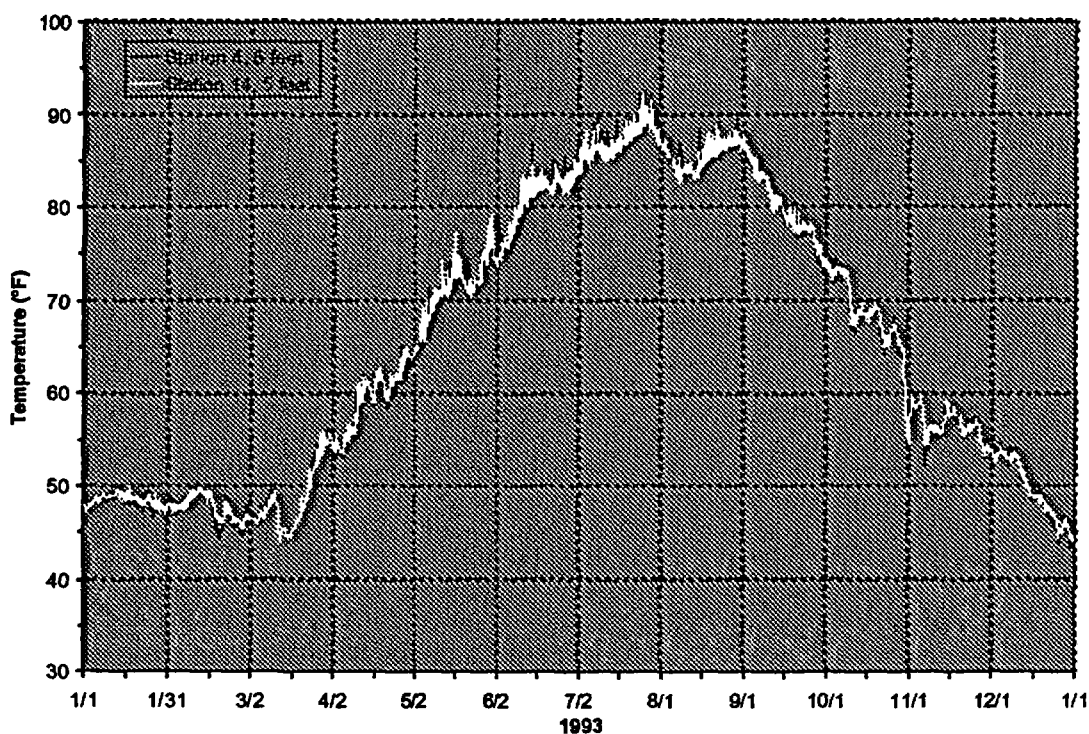

5. Page 14, end of second paragraph. Do I understand correctly that in the case of partial helper mode for a unit, the inflow conditions for the mixing zone model are actually a blend of bypassed and cooled water?

At this point in the report the intent was to inform the reader that for units operating in full open-mode, the exit conditions for the plant performance module serve as the inflow conditions for the mixing zone module for that unit's diffuser, and that for units operating in full helper-mode, the exit conditions for the cooling tower performance module serve as the inflow conditions for the mixing zone module for that unit's diffuser (i.e., no mixing for units in full open-mode or in full helper-mode). Later in the report the problem is introduced that the cooling tower lift pumps do not have sufficient capacity to carry all

the flow delivered by the CCW pumps (e.g., page 48), and that depending on the number of available cooling towers, a fraction of the CCW flow must bypass treatment via the cooling towers. For all the simulations performed in this study, partial bypass occurs only for the last unit placed on towers. In this case, the diffuser discharge for the last unit placed on towers includes a mixture of bypass water (at the condenser discharge temperature) and water from the cooling tower cold water return channel (at a temperature equivalent to the mixed temperature of all the towers in operation). For the affected unit, the mixed temperature provides the inflow conditions for the mixing zone model. Compared to the units operating in full helper-mode, this normally results in a higher diffuser discharge temperature for the last unit placed on towers, although this may not be the case if the unit is also heavily derated.

6. Page 16, line 9. Is there a reference for the river flow modeling from which the Chatanooga flows were taken?

Finding good documentation for the model used to estimate natural flows at Chattanooga is turning out to be somewhat of a challenge. The original developers departed from TVA long ago, and their files are no longer easily at hand I was able to find some binders with calibration data and a user's guide. The latter gives a brief explanation of the model, which I have attached FYI. It appears the model employs an explicit MOC scheme with runoff/discharge hydrographs as tributary BC's and local inflows.

7. Page 16, second line above figure. "Biased high"; compared to what, a longer record if it existed?

Yes, and in particular the period of record from 1948 thru 2004. If we had meaningful river temperature and meteorological data for the full period of record depicted in Figure 9 (1948 thru 2004), we could have matched, obviously, the "long-term" average hydrothermal characteristics represented by the origin of the plot.

8. Same location. This seems to imply that an analysis of wet bulb temps would lead to a similar conclusion. Do you concur?

Interesting—such an analysis could perhaps lead to statements concerning humidity and potential deviations for such things as cooling tower performance. From a seasonal standpoint (e.g., June-July-August), wet bulb temperature tracks in fashion similar to dry bulb temperature, but is not necessarily "parallel." Our instinct is that it would lead to a similar conclusion, but we would need to perform additional analysis to confirm. Again, please let us know if this is an important issue—if desired, we can pursue.

9. Page 16, general. Has there been any discussion of whether '48 – '04 can be taken as a representative period for the future?

Yes, there have been discussions, including climate change. The potential impact of climate change in the southeast is, of course, a source of uncertainty. In the supplemental EIS for the relicensing of BFN, TVA recognized that climate change

leading to warmer average ambient water temperature is a possibility. Studies by Miller et al., (1993) suggest that for reservoirs such as Wheeler, the average ambient water temperature could increase between 0.3°F and 0.5°F for each 1.0°F increase in mean air temperature. Due to the debatable aspects of the topic among TVA staff, and other professions, we have chosen to “steer clear” of sensitivity cases explicitly linked to climate change. As suggested in the report, the warmer average meteorology for the simulation years 1985-2004, compared to the entire period 1948-2004, is considered acceptable in light of the uncertainty of what the next 30 years will bring. Another reason that greater emphasis is not placed on the uncertainty of future meteorology is that BFN has significant problems with potential plant derates even in the absence of climate change.

Miller, B.A., V. Alavian, M.D. Bender, L.L. Cole, L.K. Ewing, P. Ostrowski, Jr., N.A. Nielsen, J.A. Parsley, W.D. Proctor, H.M. Samples, M.C. Shiao, and R.A. Shane, “Sensitivity of the TVA Reservoir and Power Supply Systems to Extreme Meteorology,” Tennessee Valley Authority, Resource Group, Engineering Services, Hydraulic Engineering, Report No. WR28-1-680-111, June 1993.

10. Page 19, middle of second paragraph. Does this imply that the running-24-hour temperature is examined as a compliance trigger BEFORE the one-hour temps for the 93 degree compliance?

All of the checks given below are performed in the order listed for each time step. More than one check may be “true” in a single time step.

- 1) Action levels (towers will be added, if available, but no derates to be taken)
 - i) Action level for 24-hour average downstream temperature
 - ii) Action level for 24-hour average ΔT

- 2) Unit derate points (condition at which generation will be reduced)
 - i) Derate point for 24-hour average downstream temperature
 - ii) Derate point for instantaneous (hourly) downstream temperature
 - iii) Derate point for turbine backpressure

- 3) Limit violations
 - i) 24-hour average ΔT limit
 - ii) 24-hour average downstream temperature (Note: downstream temperature may exceed limit provided the downstream temperature does not exceed upstream temperature, i.e., 24-hour average $\Delta T=0$)
 - iii) Instantaneous (hourly) downstream temperature
 - iv) Unit turbine back-pressure

11. Page 20, middle of text. Would the historical-vs-ROS flow comparisons be equally close for one-hour flows?

The statistics are slightly different, but yield the same basic conclusion. See table below.

<i>Parameter</i>	<i>ROS – Historical Hourly (°F)</i>	<i>ROS – Historical 24-hr avg (°F)</i>
<i>max diff</i>	3.24	2.92
<i>min diff</i>	-0.92	-0.86
<i>avg diff</i>	0.19	0.19
<i>rms diff</i>	0.37	0.36

12. Page 23, second paragraph. The 9.25 mile Δx for the reservoir model seems quite large – any background on this, especially in the context of possible reversing flow in the vicinity of BFN?

The large Δx is an artifact of CFL stability limitations of the explicit MacCormack scheme used to discretize the governing equations. When the model was developed in the 1970's, timely hydrothermal forecasts based on the model were not possible without a sufficiently large computational time step (20 minutes for the present case, which imposes a lower limit for Δx). For example, assuming $y = 30$ feet, $\Delta t = 20$ min, $u + c = c$, and $c = (gy)^{1/2}$, the CFL limitation would be $\Delta x > 7$ miles.

Ferrick and Waldrop (1977) presented a heuristic analysis of the explicit model stability based on the theory of characteristics. However, a rigorous linear stability analysis examining the wave amplitude and phase propagation behavior of the Wheeler Reservoir explicit model has not been developed. Comparison of measured water surface elevations at Browns Ferry with those predicted by the model show reasonable phase agreement (see Figure 8 of Ferrick and Waldrop, 1977). A limited number of periodic acoustic-Doppler flow measurements at Browns Ferry in recent years are available. Model results could be compared to these data if the phase accuracy of the model flow predictions is a major concern in the current work.

With modern computer systems, it is possible to provide more spatial resolution with additional interpolated or measured cross-sections (data are available at approximately 2 mile intervals along Wheeler Reservoir) in conjunction with a smaller time step in the explicit scheme or by switching to an implicit scheme. Doing so would require significant additional calibration work with historical flow, water surface elevation, and water temperature data. Practical experience over the last 25 years with the spatially coarse explicit Wheeler model is a significant factor justifying its continued use. TVA welcomes a discussion of the drawbacks (e.g. lack of experience) and potential benefits (e.g. enhanced amplitude and phase accuracy, better resolution of flow reversals) that a reformulation of the hydraulic model would present.

13. Page 23, third paragraph. Would it have been possible to impose $y(t)$ at Wheeler Dam rather than make volume adjustments – or would this cause numerical “pumping” from the tailwater to the reservoir in low-flow reversing situations?

Yes, our instinct is that a $y(t)$ boundary condition would cause pumping from the tailwater and add uncertainty to the computed flow at BFN. We feel that the $Q(t)$ boundary conditions provide greater confidence since releases at TVA dams are established and monitored primarily to meet a flow-based scheduling process.

14. Page 27, first paragraph. Why was the bottom temp at station 4 selected as the intake temperature? Was this validated through comparison of river temps with actual intake temps, assuming the latter are routinely monitored and logged?

The bottom temperature was selected primarily because the gates in Gate Structure 3 usually are positioned to promote a withdrawal from the bottom portion of the reservoir water column. This assumption obviously is acceptable in the absence of significant reservoir stratification and when the withdrawal zone does not entrain a significant portion of the diffuser effluent (i.e., recirculation). Unfortunately, both these behaviors are present during the critical summer period, as well as main channel-overbank variations. TVA has a water temperature monitor near Gate Structure 3 known as Station 19. This station, however, resides in an area that at times may be dominated by shear layers and shoreline flow separation. That is, sensors for this station are not positioned directly in the main body of flow entering Gate Structure 3. Comparisons between Station 19 and Station 4 confirm the complexity of local flow patterns. An example comparison is given below for the summer of 1993, showing the Station 19 bottom temperature varying between that observed at the 5-foot depth and 20-foot depth (i.e., bottom) at Station 4. In this example, the average difference between the hourly bottom temperature at Station 19 and the hourly bottom temperature at Station 4 is about 0.5°F (Station 19 warmer), and the RMS difference about 0.9°F.

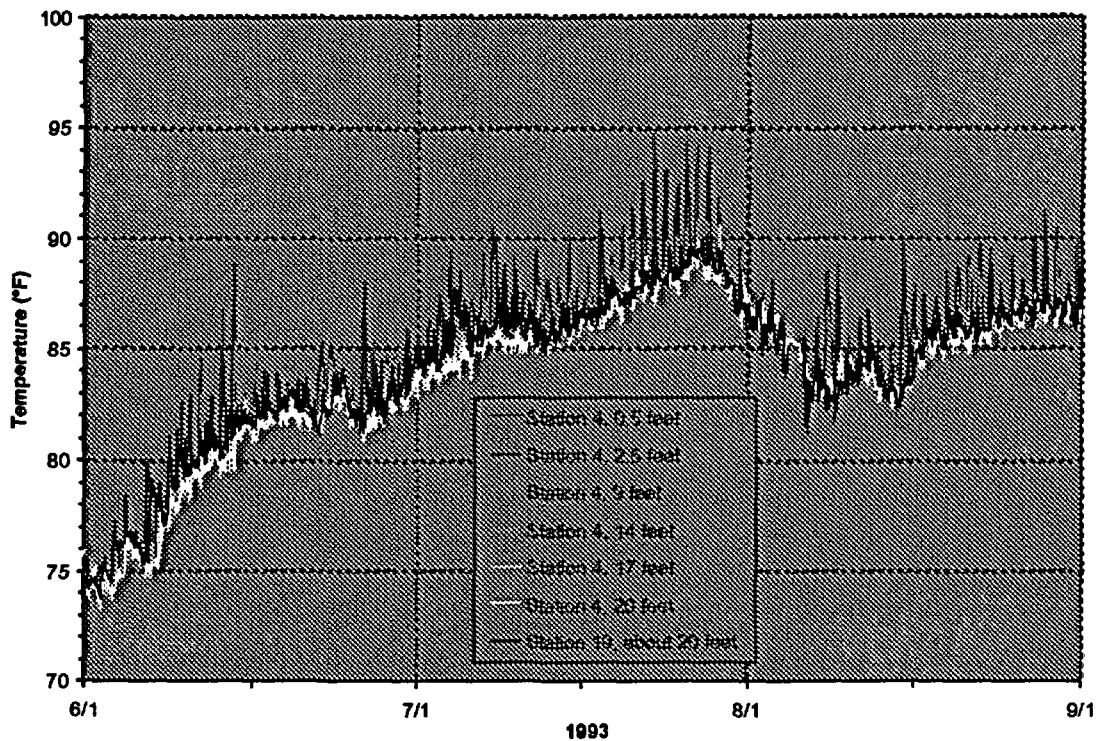

In reality, preliminary calibration studies for the hydrothermal model examined the use of the Station 19 bottom temperature for the plant intake temperature, and found no significant improvement in the computed downstream temperature compared to that obtained by using the Station 4 bottom temperature. In part, this is due to the fact that “errors” in the intake temperature are “attenuated” by the magnitude of dilution in the diffuser mixing zone. In the course of the study TVA also examined the possibility of developing a correlation including the potential impacts of river stratification and river flow. Unfortunately, schedule constraints did not allow a meaningful correlation to be determined. In the end, the fallback position included an evaluation of model sensitivity based on variations in the intake temperature (i.e., recirculation/Case 4 and uniform upstream ambient/Case 10).

TVA recognizes the importance of enhancing BFN intake temperature predictions with a more physically-based formulation. In a separate project, TVA is now investigating another model that may provide opportunities to develop scaling relationships and/or direct computations for the impact of factors such as stratification, river flow, and main channel-overbank diversity.

15. Page 28, Table 4, third column. I assume this is RMS, not “mean square”.

Correct.

16. Page 30, Figure 16. Does the higher CCW ΔT for helper mode simply reflect the reduced CCW flowrate, or am I missing something else?

Yes, it is primarily due to the reduced CCW flowrate.

17. General: Is the CCW helper-mode flowrate lower due to the decreased head across the condensers caused by backwater effects extending upstream from Gates 1A through the discharge canals?

The reduction in CCW flow is due to the increased losses associated with passing the water through the conduits to the cooling tower warm water channel (e.g., see Figure 5 and Figure 6). This brings to the attention another feature of the model that needs to be better emphasized in the report—that is, the hydrothermal model does not determine the detailed hydraulic characteristics of the flow throughout the CCW conduits and channels (e.g., HGL and EGL).

18. Page 31, first paragraph. I understand that tower capability is an overall measure of effectiveness compared to the design point, but I'm losing the handle on how it is determined or applied quantitatively. Is it simply applied to the overall design range for a specified tower discharge? Is it derived quantitatively? The first sentence can be read to imply that the capability is simply the ratio of actual to design flowrate. But that is not consistent with the 80% capability for a 92.7% flowrate in the second paragraph. Can you give me more background on this?

The capability is effectively a ratio of the percentage of heat the towers remove from the water to the amount they were designed to remove. It is determined by measuring the actual discharge flow and temperature from the tower at a known inlet flow and temperature and computing the heat removed from the water by the tower. This is compared to the heat which would be removed from the water if the tower met its design criteria. This is an oversimplification, as there are corrections for deviation from design conditions, but it basically is just a heat balance.

In the tower performance computations, the actual tower flow is divided by the capability and the "adjusted" flow is used as input to the tower algorithm. If the capability is less than 100%, this results in an increased discharge temperature.

The reduced actual flow in the older towers is not related to their capability, but results from the degradation of the tower internal water distribution systems. They simply can no longer handle the flow for which they were originally designed.

19. Page 34. I assume the ambient velocity u_a is taken as constant over the depth, right?

Yes.

20. Page 34. Have there been any discussions on how the eddies spinning off the diffuser pipes lying just upstream of #1 and #2 might affect the plane-jet model?

Note that only diffusers #1 and #3 (not #2) have pipes situated upstream. We understand that there are phenomena affecting the mixing of the diffuser effluent that are not explicitly quantified in the present mixing zone formulation, including disturbances caused by the upstream diffuser pipes. In the mixing zone model, the entrainment coefficient can be adjusted for each diffuser to account for transverse differences in mixing. To date, however, we have not examined temperature measurements in a manner to see if the impact of pipe disturbances can be recognized. In contrast, the impact of one- vs. two- vs. three-leg diffuser operation appears obvious. Thus, regardless of which legs are in service, the entrainment coefficient, at this time, varies only by the number of legs in service. Another example is the impact of the shoreline, which limits the entrainment and mixing of the diffuser #3 effluent (i.e., downstream measurements for diffuser #3 are often warmer). Although this impact is recognized, it has not yet been judged significant enough to be included in the model in an explicit manner. In general, we seek to upgrade the mixing zone module to include such phenomena as it becomes computationally feasible to do so. In the interim, we rely on sensitivity studies to provide a measure of the potential impact of such factors.

21. Page 35, 4th line after equations. How is the upper boundary of the jet defined? And generally where is the end of the integrated jet trajectory compared to the compliance monitoring probes?

The jet centerline coordinates (x,y) and jet thickness (b) are computed as part of the Runge-Kutta solution. The upper boundary of the jet is defined by the trace at half the jet width (b/2) from the jet centerline, measured normal to the centerline. The end of the jet trajectory usually falls upstream of the monitoring probes. Thus, in the calibration of the hydrothermal model, the adjustment of the effective diffuser slot width and entrainment coefficient serve to incorporate the mixing that occurs between the diffuser "boil" and the downstream monitoring stations.

22. Page 36, last paragraph. Apparently detailed records on cooling tower operation were not available for the mixing-zone model calibration periods. How was the cooling-tower operation estimated?

The period and extent of cooling tower operation were estimated based on the observed change in the measured diffuser discharge temperatures (i.e., temperature of water entering the diffuser pipes). This temperature drops significantly when a unit is placed on towers.

23. Page 37, first paragraph. Just to clarify, the plume entrainment coefficients were applied uniformly to all three diffusers, the value being determined by how many diffusers were in operation, right? At first I had the impression that a different coefficient was used for each diffuser, but I believe that was incorrect. Please confirm.

Correct.

24. Page 37, end. What were the entrainment coefficients for the unstratified model?

The unstratified model discussed in this section of the report is an altogether different model, developed in the 70's. The references below will be forwarded (TVA, 1972 and Stolzenbach, 1975). The unstratified model was used for the mixing zone module prior to the present study, and did not incorporate a scale for the impact of reservoir stratification via the 2-D buoyant jet model.

TVA, "Prediction and Control of Water Temperatures in Wheeler Reservoir During Operation of the Browns Ferry Nuclear Plant," Advance Report No. 14, Tennessee Valley Authority, Division of Water Control Planning, Engineering Laboratory, April 1972.

Stolzenbach, Keith D., "Estimation of Water Temperature Increases in Wheeler Reservoir Caused by the Discharge of Heated Water from Browns Ferry Nuclear Plant During Open Cycle Operation", February 1975.

25(a). Page 44, Table 6, Column 2. I don't understand how to interpret "active legs" for the entire year. Are these representative values?

This column indicates the number of diffuser legs estimated to be in operation during the year. The column entitled "Sample Size" gives a measure of the fraction of the year the indicated number of diffuser legs was in service. For example, in 1993, only one of the three BFN units was in service (i.e., Unit 2). Thus, in open-open cycle operation, only one diffuser leg was in service. Furthermore, for the entire year, one-leg operation occurred for roughly 8504 model time-steps (1-hour), or $8504/(8504+255)=97\%$ of the year. Cooling tower operation also occurred in 1993. During cooling tower operation, all three diffusers were placed in operation. For the entire year, this alignment occurred for 255 model time-steps, or $255/(8504+255)=3\%$ of the year. In all the years chosen for the model calibration, cooling tower operation with three diffuser legs occurred only in the summer. Thus, for three-leg operation, the RMS and AVG statistics are the same for January through December (Table 6) and June through August (Table 7). The calibration effort focused on obtaining the best agreement between computed and actual temperatures for the summer months, when cooling tower operation and derates will occur. In connection with Tables 6 and 7, please note that the titles for Figures 21 through 24 should be for two-unit operation rather than one-unit operation.

25(b). General. What was the influence of transient reverse river flow on the various mixing-zone and entrainment models? Presumably these occurred for one to a few hours during many low-flow periods of the simulation, but the report doesn't appear to provide any specifics on how this may have been dealt with other than in Case 4, which does not seem to deal with bulk or massive reverse flow.

For reverse flow, the ambient velocity (u_e) is less than zero in the buoyant jet model. Thus $d(x\text{-momentum})/ds < 0$ and the buoyant jet tends to decelerate and shift toward the upstream direction.

26. Page 45, last sentence. I don't quite understand. In open cycle, a unit's CCW flow goes directly to its own diffuser. Therefore I don't see how the continued CCW flow for a unit that is shut down provides any additional dilution for the still-running units, except possibly through the mixing-zone dynamics. Is this what is implied?

Yes. In practice this is observed primarily by the fact that via the NPDES permit, the diffuser for the shut down unit is yet active. Thus, the temperature measured by the monitor located downstream of this diffuser will be included in the average for the downstream temperature. And since this temperature, in all likelihood, will be cooler than that for monitors downstream of units releasing heat, the overall average downstream temperature will be attenuated.

27. Page 45, general. This leads to the question: how is the tower return flow distributed into the diffusers? Is there a headbox from which the cooled water naturally allocates itself through the dropshafts to result in a constant upstream head in each diffuser? Since the tower return flow is free-surface as I understand it, is there any control over the distribution of tower return flow among the three diffusers, other than the total flow through gate structure 1?

Yes, the cooling tower cold water return channel can be thought of as a headbox for Gate Structure 1. The gates in Gate Structure 1 can be closed for each unit to control the discharge from the cold water return channel to the unit's diffuser; however, in practice, all of the gates usually are kept full open at all times. In the model, if a unit is in full open-mode while others are in helper-mode, it is assumed that the head for the open-mode unit prohibits significant flow in the cold water return channel from entering its diffuser.

28. Page 46, Table 8. This is a bit editorial, but does assumption 5 belong in the table, since it seems to be a parameter for implementation of the model, rather than a constraint on plant operation? Or is 50 MW in fact an operational increment?

You are correct. The 50 MW increment is used in the model only as a parameter to iterate for a solution.

29. Page 46, assumption 14. Again excuse my ignorance, but how does the backpressure limitation get implemented in the model? Does it enter into the condenser performance algorithms and/or the turbine/generator output?

Yes, the backpressure is computed by the plant performance module. The computed value is examined, and if it exceeds the 5.5 in Hg limit, the unit generation is reduced. This seldom, if ever, occurs in open- and helper-mode with three CCW pumps per unit. It can become a factor if number of CCW pumps is reduced, and would definitely be a problem if closed-mode operation was implemented.

30. Page 47, Table 8, assumption 43. This goes back to my question 27 above. Does it imply then that keeping the CCW flow running for a shut-off unit provides additional dilution simply by enhancing mixing in the mixing zone?

Yes. Because the CCW conduits supply flow for other plant systems, and allow a quicker recovery from derates or unintentional shutdowns, the CCW pumps are seldom turned off.

31. Page 48, line 12. More of the same question, see my question 27 above.

We recognize that due to differences in the geometry of the flow conduits and variations in the approach conditions at Gate Structure 1, minor difference will occur for the amount of discharge entering each of the diffusers from the cold water return channel. We feel that in the absence of field measurements and/or a rigorous hydraulic analysis of the flow configurations, an even distribution of flow among the units not in open-mode is adequate.

32. Page 49, second bullet. Is the order of adding CTL pumps the same irrespective of environmental parameters, in particular the wet bulb temperature?

Yes, the better towers are assumed to be better regardless of wet bulb temperature.

33. Page 49, item 8, bottom. Presumably a lift pump may have to continue operating past its minimum 8 hour duty, right? Is it then removed from duty and then possibly returned based on the new computation of the compliance temps?

If, at hour 9, the pump is turned off and computations indicate a resulting violation, the time step is repeated with the pump still on. The 8 hour minimum counter does not reset unless the pump can be turned off and left off for at least one hour.

34. Page 50, item 3. Maybe an obvious question, but why is the turbine backpressure affected by tower operation? Is it through the decreased condenser efficiency at the lower CCW flowrate caused by the discharge-channel backwater effect?

Yes, and it's a good question.

35. Page 50, fourth line from bottom. Presumably this shutoff of lift pumps is subject to the constraint of 8-hour minimum duty. Are there cases in which the lift pumps are kept on but the fans shut off, in the interest of pump duty and flow balance?

In the model, no, but in practice, yes, although perhaps for a different reason. The only time this might be considered is for ice control during winter operation. The model simulations identified no events for cooling tower operation in the winter (i.e., to control ΔT), but our instinct is that a non-negligible likelihood for such yet exists, particularly during winter droughts of sufficient duration to promote higher levels of effluent recirculation. To minimize damage due to freezing, the towers might be run without fans, at least for a sufficient period of time at startup to warm the tower above freezing, and perhaps longer. In general, fans are turned off when both tower lift pumps are off. The piping for the towers is designed to deliver water across the entire length of the tower on both sides when either one or two lift pumps are in service. Thus all tower fans are assumed to be in service when one or both tower lift pumps are in operation.

36. Page 59, case 1. Was consideration given to reducing tower availability by taking an old one off line on a random basis, rather than simply assuming that the new one would be unavailable?

No. Tower 4 was selected to be unavailable for two reasons. First, it provides the worst case scenario (i.e., removes the largest tower). Second, the justification for restoring Tower 4 is unresolved, thus TVA was interested in seeing the potential impacts under existing conditions (i.e., no Tower 4).

37. Page 62, case 4. Is there a reference for development of this recirculation algorithm? Does it apply to the case of bulk reverse flow or only to the effect of the large eddy? If the latter, was this derived from the earlier 3D model and drogue studies?

It is only intended to describe the impact of the large eddy. No references exist. This and the re-entrainment algorithm are back-of-the-envelope scaling procedures developed in an attempt to get the model to better agree with field measurements, without resorting to a prohibitively time-consuming multi-dimensional formulation. Most of the development and use of the BFN hydrothermal model has been for real-time forecasting, and in critical periods involving cooling tower operation and derates, the model is run regularly throughout the day. As a result, run times need to be brief.

TVA recognizes that the theoretical bases for the recirculation and re-entrainment algorithms are extremely weak. This is confirmed by the fact that sometimes the algorithms perform well, and at other times, for reasons not yet understood, the algorithms perform poor. Despite such, they are at this time the most convenient methods available to TVA for evaluating the uncertainty of these processes in sensitivity studies. The modeling effort mentioned in our response to question 14 also may lead to improvements in predicting recirculation and re-entrainment. Internal discussions have also included the use of a combination of multidimensional CFD modeling, statistical

methods, and neural nets to come up with better algorithms for these processes. Recommendations in this area are very welcome.

38. Page 62, 4 lines above case 5. Can you give a bit more detail on how the plume temp from the previous time step is used to approximate the travel time?

It is recognized that some travel time is required for the plume to migrate upstream, thus the current plume temperature is obviously unacceptable. Drogue studies conducted in 1996 and 1999 measured upstream currents in the surface region upstream of the diffusers of about 0.25 fps when the river flow dropped below about 5000 cfs. Based on a distance of 1000 feet between the diffusers and Gate Structure 3, this yields a travel time of magnitude 1.1 hour for the potential emergence of recirculation effects. Thus, a lag of one hour is considered to be an acceptable estimate.

39. Page 63, case 6. I gather from this case that tower evaporative mass loss is taken into account. Do have a rough idea of what % of the flowrate through a tower is lost to evaporation in typical conditions?

Yes, evaporative losses are included. Based on the individual tower inflow and outflow numbers in the hourly output files, the evaporation percentage is about 2% for the old (Ecodyne) towers and 2.5% for the new (Balke-Durr) towers.

40. Page 63, Case 7, third line. I assume that "heat flowrate" is meant rather than "heat rate".

Correct.

41. Page 63, Case 9, third line. I don't quite follow this. Should it be "Unit 3 diffuser"?

Unit 1 is correct. The point that is trying to made here is that TVA has virtually no prototype data to confirm the validity of using 0.25 as an entrainment coefficient when the plant is operating with three diffuser legs in service. The plant was operated with all three legs in service in the early years of the facility, when all three units were running, but not with the current configuration of the instream monitoring system. Since the restart of the plant (containing the current instream monitoring system), operation with three diffuser legs occurs only when the cooling towers are in service. With only Units 2 and 3 presently running, the operation of the Unit 1 diffuser leg is essentially idle, except during cooling tower operation. And when cooling tower operation occurs, it usually is with one unit in open-mode and one unit in helper-mode, creating a situation where the open-mode diffuser is discharging the full flow and heat of one unit, while the remaining two diffusers, receiving flow from the cold water return channel, only have 50% of the flow and a substantially reduced amount of heat. The bottom line is that prototype data with all three diffuser legs in service and equally "loaded", preferably with all three units at full power, is nonexistent for the purpose of helping us obtain a good measure of the appropriate entrainment coefficient for three-leg operation. (Also recall that at this point in time we have chosen not to vary the diffuser coefficient "laterally" among the

diffusers in a manner that perhaps would attempt to account for the type of operation that currently exists with two units on towers). Under these circumstances we stepped back and examined computed temperatures given by the "original" (old) mixing zone model (introduced in our response to question 24). The original unstratified model is rooted in physical model studies conducted for the diffuser system, and thus was considered adequate to determine a potential "upper bound" for the entrainment coefficient for three-leg diffuser operation in the sensitivity studies. Thus, for the period of record indicated in Figure 30, the entrainment coefficient for the buoyant jet model was adjusted until the computed maximum temperatures were of the same magnitude as those obtained by the original unstratified model.

TVA recognizes that information in the report related to the original unstratified model is weak and confusing. Along these lines, it should be emphasized that the results for Case 10, containing a uniform upstream ambient, were derived by the buoyant jet model, not the original unstratified model.

42. Page 64. I know that this presentation is the one that makes sense thermodynamically. But it would be easier to get one's head into tower performance if we had wet bulb on the abscissa, range on the ordinate, and curves for various hot-side temps. From that one could quickly come up with the cold-side temp. Not a big deal.

Based on our experience, Figure 28 is the typical manner that cooling tower performance curves are displayed; however, it is more meaningful for closed-cycle plants. We can reconfigure the plots.

43. Page 65, line 2. Could you provide some additional thoughts on why the old unstratified model tends to compute higher instream temp rises than the stratified one, for the same coefficients?

The answer to question 41 should help here. Answering the question relative to the behavior of the stratified (buoyant jet) model, in general, since a significant portion of the mixing of the diffuser effluent takes place near the bottom of the channel where the temperature of the ambient is cooler and entrainment m_e is higher, the stratified model tends to yield a lower temperature near the surface, and therefore a lower instream temperature rise than the original unstratified model.

44. Page 67, last line of case 10 and elsewhere. Are we really talking about a "dilution" reduction, or an increase in near-field temperature that looks like a dilution reduction? To me, dilution should refer only to volumetric mixing. Maybe I'm missing something here.

We concur that "dilution" is a poor choice of word. The term was repeated from a TVA reference that defined the dilution of the effluent in terms of temperature,

$$D = \frac{T_o - T_{u/s}}{T_{d/s} - T_{u/s}},$$

where T_o is the diffuser outlet temperature, $T_{u/s}$ the upstream ambient temperature and $T_{d/s}$ the downstream mixed temperature.

Appendix B

Miscellaneous typographical errors

Page	Location	Anomaly
iii	Figs. 21-24	“one” should be “two”
4	1 st line of 2 nd para	“are” should be “is”
4	3 rd line of 3 rd para	“are” should be “is”
15	4 th line	“are” should be “is”
19	5 th line	“behaviors” should be “behavior”
19	6 th line	“the BETTER” should be “BETTER”
20	2 nd line	“computer” should be “computed”
20	5 th line from end	Text beginning “Provided in ...” to end is redundant, should be deleted since it appears on the next page
28	Table 4	Heading of 3 rd column should be “Root Mean-Square”
29	3 rd line from end	“is” should be “are”
30	2 nd line from end of 1 st para	“Only one of which (Tower 3) has been...” should be “Only Tower 3 has been....”
33	Figure 18	“u _b ” should be “u _e ”
48	2 nd line	“its” should be “it’s”
51	3 rd line	“...load 440....” should be “...load is 440....”
53	7 th line	“was” should be “were”
59	1 st line	“plant;” should be “plant”
59	3 rd line, 2 nd para	“assuming” should be deleted
59	1 st line, 3 rd para	“towers” should be “tower”
63	3 rd line, 3 rd para	“heat rate” should be “heat flowrate”
63	3 rd line, last para	“is” should be “are”
68	3 rd bullet in Fig 32 para	“enery” should be “energy”
75	10 th line	“yield” should be “yields”
79	1 st line	“is” should be “are”
79	2 nd line from end	“was” should be “were”