

NFPA 805 NRC Pilot Observation Meeting Progress Energy Introductory Remarks Paul Gaffney

**Charlotte, NC
November 7, 2005**



NFPA 805 Pilot Observation Meeting

Progress Energy (PE) Attendees:

- ▶ Paul Gaffney, Chief Electrical/I&C Engineer
- ▶ Jeff Ertman, NFPA 805 Transition Project Manager
- ▶ Tony Maness, HNP Site NFPA 805 Project Lead
- ▶ Bob Rishel, Acting PRA Supervisor
- ▶ Ken Heffner, Lead Licensing Engineer
- ▶ Mike Fletcher, HNP FP Program Manager
- ▶ Liz Kleinsorg, KGRS
- ▶ Roger Sims, KGRS
- ▶ Andy Ratchford, RDS

NFPA 805 Pilot Observation Meeting

Progress Energy Pilot & NFPA 805 Goals

- Focus on Nuclear Safety
- Restore Fire Protection Compliance
- Clean up licensing basis

NFPA 805 Pilot Observation Meeting Overview PE Schedule

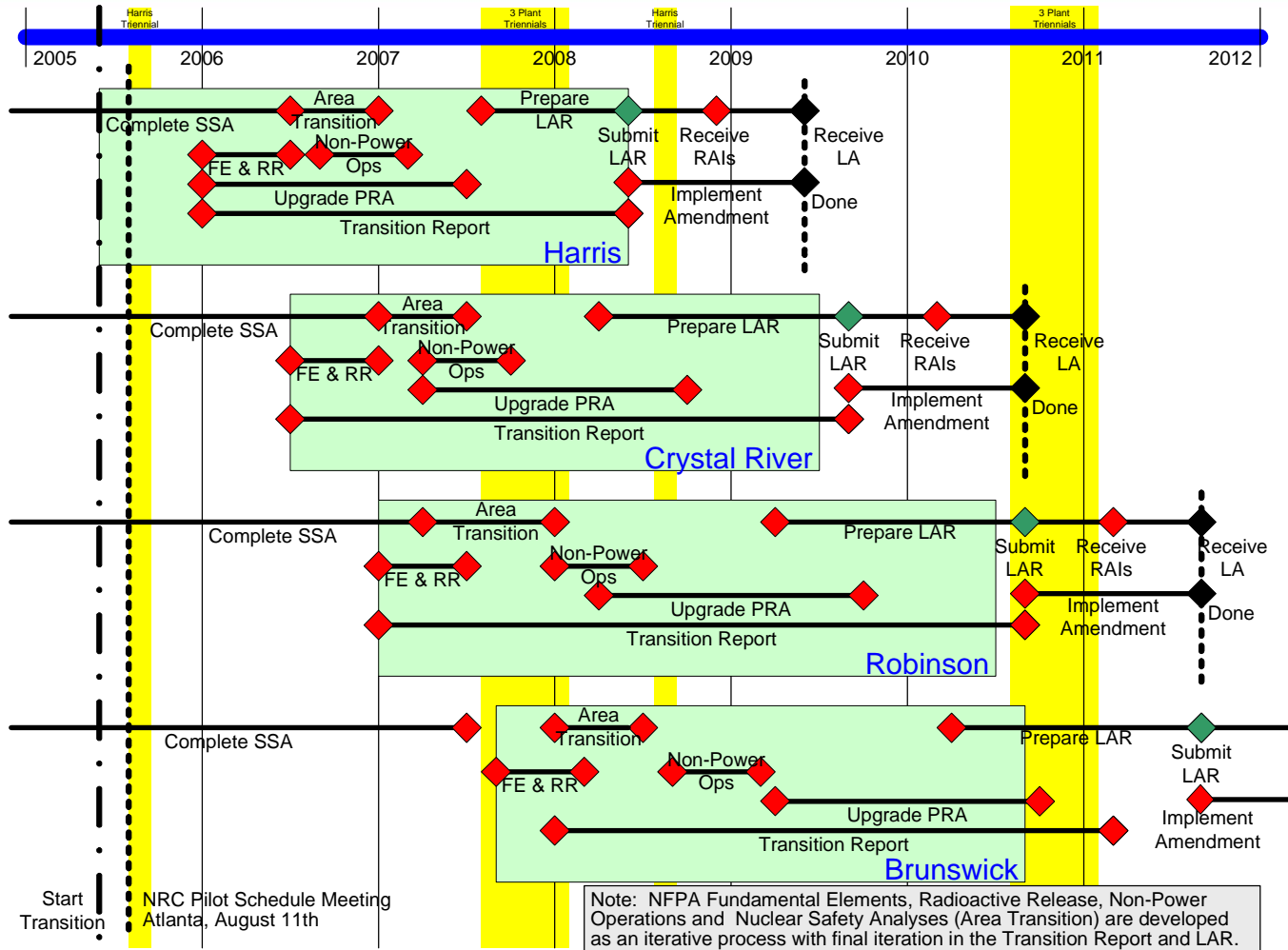

NFPA 805 Pilot Observation Meeting PE Status SSA Validation Schedule

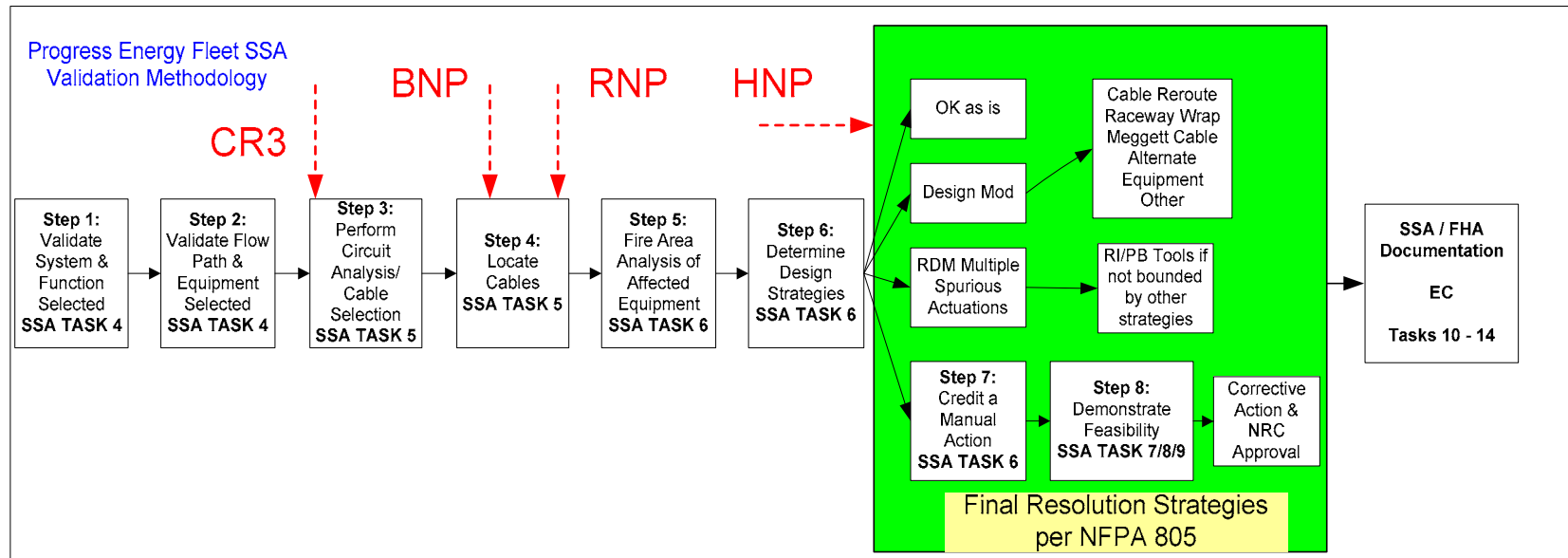

NFPA 805 Pilot Observation Meeting

Key Pilot Interactions (From 8/11/05)

- NSPA (SSA) Transition - Comparison to NEI 00-01
 - ▶ Multiple circuit failures
 - ▶ Recovery Action evaluations T-H & HRA
- Chapter 3 Transition
- Internal Events PRA / Fire PRA
- Fire Modeling
- Radioactive release during firefighting activities
- Non-power operations
- RI change evaluation process
- Fire Protection Performance Monitoring
- Tracking of FP deficiencies for resolutions under NFPA 805 / Enforcement Discretion

NFPA 805 Pilot Observation Meeting

PE NFPA 805 Transition Project Approach

- Through 2005
 - Detailed planning, procedure/process development, and team assembly
 - Develop Methodology to address deficiencies under enforcement discretion policy
 - Develop draft of FP change process procedure
 - Fire PRA Gap review
 - NEI 00-01 comparison to PE SSA methodology
- Continue work HNP SSA Validation
 - NRC Triennial Inspection
 - Prioritize open SSA Validation issues
- Scheduled to start PRA work and Chapter 3 Transition in early 1Q2006