



Entergy Nuclear Northeast
Indian Point Energy Center
450 Broadway, GSB
P.O. Box 249
Buchanan, NY 10511-0249
Tel 914 734 6700

Fred Dacimo
Site Vice President
Administration

December 14, 2005
NL-05-136

U.S. Nuclear Regulatory Commission
ATTN: Document Control Desk
Mail Stop O-P1-17
Washington, DC 20555-0001

SUBJECT: Indian Point Nuclear Generating Unit 2
Docket No. 50-247
**NRC First Revised Order EA-03-009; Relaxation Request
for Inspection of IP2 Reactor Pressure Vessel Head**

- REFERENCES:
1. NRC Order EA-03-009, "Issuance of First Revised NRC Order (EA-03-009) Establishing Interim Inspection Requirements for Reactor Pressure Vessel Heads at Pressurized Water Reactors", dated February 20, 2004
 2. Entergy letter NL-04-060, "NRC First Revised Order EA-03-009, Relaxation Requests for Inspection of Reactor Pressure Vessel Heads", dated May 19, 2004

Dear Sir:

Entergy Nuclear Operations, Inc (Entergy) is submitting a relaxation request pertaining to inspection of the Indian Point Nuclear Generating Unit 2 (IP2) Reactor Pressure Vessel (RPV) head in accordance with NRC First Revised Order EA-03-009 (Reference 1). The relaxation request concerns non-destructive examination (NDE) of the nozzle region below the J-groove weld. Due to the physical dimensions of the nozzles and the presence of a threaded region at the bottom of the nozzles, relaxation is needed regarding the requirement in NRC First Revised Order EA-03-009, section IV.C.5(b). Entergy is requesting that the relaxation be applicable to those penetrations with inspection coverage of less than 1 inch below the J-groove weld as specified in Attachment 1. Note that the previously approved relaxation request regarding extent

A101

of coverage for the bare metal visual examination of the RPV head (Reference 2) remains in effect.

A response to this relaxation request is needed by April 1, 2006 to support the IP2 refueling outage planned for Spring 2006. One new commitment is made in this letter; see Attachment 2. If you have any questions or require additional information, please contact Mr. Patric W. Conroy at 914-734-6668.

Sincerely,



Fred R. Dacimo
Site Vice President
Indian Point Energy Center

Attachment 1 (Relaxation Request For IP2 Regarding Ultrasonic and Eddy Current Testing of Reactor Pressure Vessel Head Nozzles in Accordance with First Revised NRC Order EA-03-009, Section IV.F.)

Attachment 2 (List of Commitments)

cc: Mr. John P. Boska, Senior Project Manager, Section 1
Project Directorate I
Division of Licensing Project Management
U.S. Nuclear Regulatory Commission

Mr. Samuel J. Collins
Regional Administrator, Region 1
U.S. Nuclear Regulatory Commission

Resident Inspector's Office
Indian Point Unit 2 Nuclear Power Plant
U.S. Nuclear Regulatory Commission

Mr. Paul Eddy
New York State Public Service Commission

ATTACHMENT I TO NL-05-136

**RELAXATION REQUEST FOR IP2 REGARDING ULTRASONIC AND EDDY CURRENT
TESTING OF REACTOR PRESSURE VESSEL HEAD NOZZLES IN
ACCORDANCE WITH FIRST REVISED NRC ORDER EA-03-009, SECTION IV.F.**

A. ASME COMPONENTS AFFECTED

Component Number: B4.12

Description: Reactor Pressure Vessel (RPV) Head Penetration Nozzles

Code Class: 1

B. REQUIREMENTS OF FIRST REVISED NRC ORDER EA-03-009

Section IV.C.5(b)(i) of the Revised Order (Reference 1) requires ultrasonic testing (UT) of the RPV head penetration nozzle volume (i.e., nozzle base material) from 2 inches above the highest point of the root of the J-groove weld (on a horizontal plane perpendicular to the nozzle axis) to 2 inches below the lowest point at the toe of the J-groove weld ... OR **1.0 inch** below the lowest point at the toe of the J-groove weld ... including all RPV head penetration nozzle surfaces below the J-groove weld that have an operating stress level (including all residual and normal operating stresses) of 20 ksi tension or greater.

Section IV.C.5(b)(ii) of the Revised Order (Reference 1) provides an option to perform eddy current testing (ECT) or dye penetrant testing (PT) of the entire wetted surface of the J-groove weld and the wetted surface of the RPV head penetration nozzle base material from at least 2 inches above the highest point of the root of the J-groove weld (on a horizontal plane perpendicular to the nozzle axis) to 2 inches below the lowest point at the toe of the J-groove weld ... OR **1.0 inch** below the lowest point at the toe of the J-groove weld ... including all RPV head penetration nozzle surfaces below the J-groove weld that have an operating stress level (including all residual and normal operating stresses) of 20 ksi tension or greater.

C. PROPOSED ALTERNATIVE

Entergy Indian Point 2 will perform UT from the inside surface of each RPV head penetration nozzle (i.e., nozzle base material) from 2 inches above the J-groove weld and extending down the nozzle to at least the top of the threaded region or further down the threaded region to the extent allowed by technology and geometry, but in all cases achieving the minimum requirements specified in Table 1. Although not presently planned, Entergy may choose to perform ECT in lieu of UT of the wetted surface excluding any threaded

surfaces and the chamfer region in selected nozzles. If ECT is performed, the minimum requirements of Table 1 will apply. The 2R17 refueling outage is currently scheduled for April, 2006. The next non-visual NDE inspection of the RPV head is currently planned for the spring of 2010 during 2R19. Indian Point 2 is expected to remain in the moderate susceptibility category past the 2R18 refueling outage.

D. REASON FOR RELAXATION REQUEST

The proposed alternative provides an acceptable level of quality and safety.

E. JUSTIFICATION

The design of the RPV head penetration nozzles (see Figure 1-1) includes a threaded section, approximately $\frac{3}{4}$ inches long, at the bottom of the nozzles. The dimensional configuration at some nozzles is such that the inspectable distance from the lowest point of the toe of the J-groove weld to the bottom of the scanned region is less than the 1-inch lower boundary limit specified in Section IV.C.5(b) of the First Revised Order. Review of previous NDE data shows that in some cases 1" coverage cannot be achieved. Entergy will attempt to maximize coverage to comply with the First Revised NRC Order (Ref.1).

UT from the inside surface of the threaded region of the nozzle is now partially achievable by new vendor scanning techniques, previously not available in IP2 refueling outage 2R15. ECT probes are not capable of examining the threaded surfaces. Although dye penetrant testing (PT) of threaded surfaces is possible, it would require that personnel be located under the RPV head to manually perform the surface cleaning and penetrant testing operations, resulting in significant personnel radiation exposure. During 2R15, a PT of a weld was performed under the RPV head on an indication at a person rem exposure of 1.7 REM. Therefore, UT from the inside surface of the threaded region of the nozzle is the primary method at IP2 to remotely inspect the portion of the nozzle below the J-groove weld to minimize radiation exposure to inspection personnel.

Entergy performed stress analysis and crack growth evaluations for postulated through-wall axial flaws extending upwards from the nozzle towards the lower J-groove weld. The time to reach the lowest point at the toe of the J-groove weld is greater than 4 EFPY (Table 1) based on a minimum inspection coverage below the J-groove weld.

The performed stress analysis consisted of a three-dimensional elastic-plastic finite element analysis that considered all the pertinent loadings on the penetrations. The three-dimensional finite element model comprised of iso-parametric brick and wedge elements was used to obtain the stresses.

The penetration nozzle, weld metal, cladding and the vessel head were modeled in accordance with the relevant material properties. The most important loading conditions were

found to be those which normally exist on the penetration nozzle in the majority of cases. These loadings included pressure and temperature loading associated with the steady state operation condition. In addition, the residual stresses resulting from the weld fabrication process were also considered.

The crack growth evaluation for a hypothetical flaw used the MRP-55 recommended PWSCC crack growth rate taking into account a head temperature of 593.2° F. Entergy recognizes that the NRC staff has not yet made a final determination on the acceptability of MRP-55. Should the staff determine the crack growth formula used by Entergy is unacceptable, Entergy will revise the analysis that justifies relaxation of the First Revised Order within 30 days after the NRC advises Entergy of an NRC approved crack growth formula. If the revised analysis shows that the crack growth acceptance criteria are exceeded prior to the end of the then current operating cycle, this relaxation will be considered rescinded and written justification for continued operation shall be submitted to the NRC within 72 hours. If the revised analysis shows that the crack growth acceptance criteria are exceeded during the subsequent operating cycle, Entergy will submit the revised analysis for NRC review within 30 days. If the revised analysis shows that the crack growth acceptance criteria are not exceeded during the current operating cycle or the next operating cycle, Entergy shall confirm that the analysis was performed in a letter to the NRC within 30 days. Any crack growth analyses performed for RPV head inspections after the NRC advises Entergy of an NRC approved crack growth formula shall use that formula.

The service life required for any of the upper crack tips to reach the lowest point of the toe of the J-groove weld all exceeded 4 EFPY. The time duration between inspection cycles is 4 years in accordance with the NRC First Revised Order for moderate category plants. IP2 is expected to remain as a moderate category plant past 2R18. Therefore, as a screening rule, if inspection coverage of Table 1 is achieved below the J-groove weld on the downhill side of all the head penetration nozzles in 2R17, the upper crack tip of any undetected axial through-wall flaw in the region not being inspected is not expected to reach the lowest point of the toe of the J-groove weld in less than 4 EFPY, or before the subsequent 2R19 nozzle inspection. Consequently, the intent of the requirements in the NRC First Revised Order is met.

It should be noted that for those head penetrations where information on the inspection coverage is not available, it is assumed that the inspection coverage for those penetrations are comparable to those obtained for nozzles in the same vicinity. There are a total of 5 penetrations that were not examined in 2R15. These are penetration numbers 1, 6, 7, 9 and 77.

F. DURATION OF RELAXATION

Entergy requests relaxation of this requirement for all nozzle inspections to be performed in 2R17 and in future outages in accordance with the Order EA-03-009.

G. ATTACHMENTS TO RELAXATION REQUEST

Table 1: IP2 RPV Head Penetrations – Minimum Coverage Requirements Below J-Groove Weld

Figure 1-1: IP2 RPV Head Penetrations – Nozzle Weld Detail

H. REFERENCES

1. NRC Letter dated February 20, 2004, “Issuance of First Revised NRC Order (EA-03-009) Establishing Interim Inspection Requirements for Reactor Pressure Vessel Heads at Pressurized Water Reactors”
2. Westinghouse Letter dated November 2005, “Technical Justification to Support Submittal of Relaxation Request from NRC Order EA-03-009 for Indian Point Units 2 and 3”

TABLE 1
IP2 RPV Head Penetrations – Minimum Coverage Requirements Below J-Groove Weld

Nozzle Penetration No.	Angle of Incidence (Degrees)	⁽¹⁾ Minimum Required UT Coverage Below J-Groove Weld with > 4 EFPY by Crack Growth Evaluation (Inches)	Time (EFPY) to Reach the Lowest Point of the Toe of the J-Groove Weld
1 through 25	0 to 23.3	0.55	4.6
26 through 69	24.8 to 38.6	0.45	4.4
70 through 81	44.3	0.25	8.4
82 through 89	45.4	0.25	6.8
90 through 97	48.7	0.18	5
Note:			
(1) Length below the lowest point at the toe of the J-groove weld (downhill side) that has an operating stress level of 20 ksi: 0.86 inches at nozzles 1 through 25; 0.40 inches at nozzles 26 through 69; 0.32 inches at nozzles 70 through 81; 0.34 inches at nozzles 82 through 89 and 0.32 inches at nozzles 90 through 97.			

FIGURE 1-1

IP2 RPV Head Penetrations – Nozzle Weld Detail

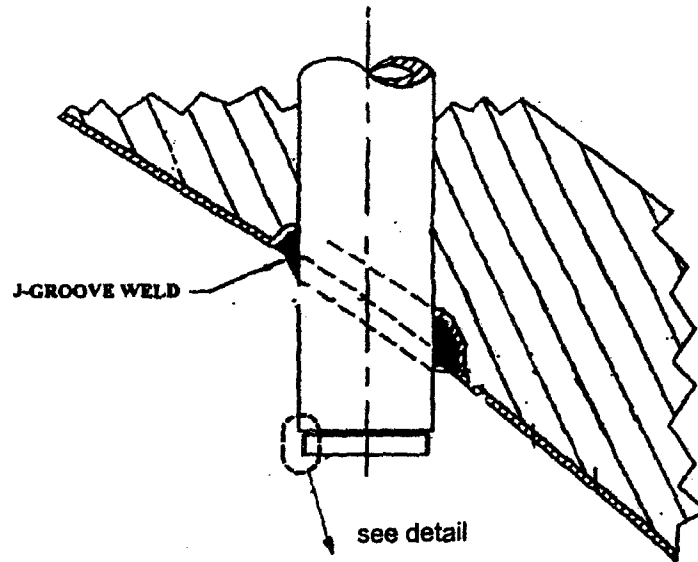

reference datum – bottom of J-groove weld

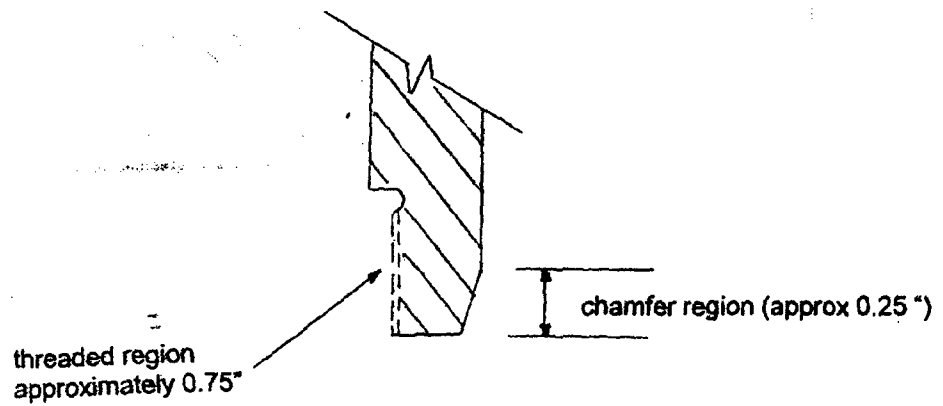

List of Commitments

Number	Commitment
NL-05-136-1	<p>Entergy recognizes that the NRC staff has not yet made a final determination on the acceptability of MRP-55. Should the staff determine the crack growth formula used by Entergy is unacceptable, Entergy will revise the analysis that justifies relaxation of the First Revised Order within 30 days after the NRC advises Entergy of an NRC approved crack growth formula. If the revised analysis shows that the crack growth acceptance criteria are exceeded prior to the end of the then current operating cycle, this relaxation will be considered rescinded and written justification for continued operation shall be submitted to the NRC within 72 hours. If the revised analysis shows that the crack growth acceptance criteria are exceeded during the subsequent operating cycle, Entergy will submit the revised analysis for NRC review within 30 days. If the revised analysis shows that the crack growth acceptance criteria are not exceeded during the current operating cycle or the next operating cycle, Entergy shall confirm that the analysis was performed in a letter to the NRC within 30 days. Any crack growth analyses performed for RPV head inspections after the NRC advises Entergy of an NRC approved crack growth formula shall use that formula.</p>