



A subsidiary of Pinnacle West Capital Corporation

Palo Verde Nuclear
Generating Station

Cliff Eubanks
Vice President
Nuclear Operations

Tel (623) 393-6116
Fax (623) 393-6077

Mail Station 7602
PO Box 52034
Phoenix, Arizona 85072-2034

102-05387-CE/SAB/DJS
December 8, 2005

ATTN: Document Control Desk
U.S. Nuclear Regulatory Commission
Washington, DC 20555-0001

Dear Sirs:

**Subject: Palo Verde Nuclear Generating Station (PVNGS)
Units 2 and 3
Docket Nos. STN 50-529 and 50-530
License Nos. NPF 51 and NPF 74
Licensee Event Report 2005-005-00**

Attached please find Licensee Event Report (LER) 50-528/2005-005-00 prepared and submitted pursuant to 10 CFR 50.73. This LER reports a shutdown required by Technical Specifications LCO 3.0.3.a based on Unit 2 and Unit 3 declaring both trains of the Emergency Core Cooling Systems (ECCS) and Containment Spray Systems INOPERABLE due to the Refueling Water Tank (RWT) being INOPERABLE.

In accordance with 10 CFR 50.4, copies of this LER are being forwarded to the NRC Regional Office, NRC Region IV and the Senior Resident Inspector. If you have questions regarding this submittal, please contact Daniel G. Marks, Section Leader, Regulatory Affairs, at (623) 393-6492.

The corrective actions described in this LER are not necessary to maintain compliance with regulations.

Arizona Public Service Company (APS) makes no commitments in this letter.

Sincerely,

CE/SAB/DJS/ca

Attachment

cc: B. S. Mallett NRC Region IV Regional Administrator
M. B. Fields NRC NRR Project Manager
G. G. Warnick NRC Senior Resident Inspector for PVNGS

LICENSEE EVENT REPORT (LER)

(See reverse for required number of digits/characters for each block)

Estimated burden per response to comply with this mandatory collection request: 50 hours. Reported lessons learned are incorporated into the licensing process and fed back to industry. Send comments regarding burden estimate to the Records and FOIA/Privacy Service Branch (T-5 F52), U.S. Nuclear Regulatory Commission, Washington, DC 20555-0001, or by internet e-mail to infocollects@nrc.gov, and to the Desk Officer, Office of Information and Regulatory Affairs, NEOB-10202, (3150-0104), Office of Management and Budget, Washington, DC 20503. If a means used to impose an information collection does not display a currently valid OMB control number, the NRC may not conduct or sponsor, and a person is not required to respond to, the information collection.

1. FACILITY NAME Palo Verde Nuclear Generating Station (PVNGS) Unit 2	2. DOCKET NUMBER 05000529	3. PAGE 1 OF 8
---	-------------------------------------	--------------------------

4. TITLE
TS Required Reactor Shutdown – LCO 3.0.3 A Inoperable ECCS, Containment Spray & Refueling Water Tank

5. EVENT DATE			6. LER NUMBER			7. REPORT DATE			8. OTHER FACILITIES INVOLVED	
MONTH	DAY	YEAR	YEAR	SEQUENTIAL NUMBER	REV NO.	MONTH	DAY	YEAR	FACILITY NAME	DOCKET NUMBER
10	11	2005	2005	- 005 -	00	12	08	2005	PVNGS Unit 3	05000530
									FACILITY NAME	DOCKET NUMBER
										05000

9. OPERATING MODE 1	11. THIS REPORT IS SUBMITTED PURSUANT TO THE REQUIREMENTS OF 10 CFR§: (Check all that apply)							
10. POWER LEVEL 100	<input type="checkbox"/> 20.2201(b)	<input type="checkbox"/> 20.2203(a)(3)(I)	<input type="checkbox"/> 50.73(a)(2)(I)(C)	<input type="checkbox"/> 50.73(a)(2)(vii)				
	<input type="checkbox"/> 20.2201(d)	<input type="checkbox"/> 20.2203(a)(3)(II)	<input type="checkbox"/> 50.73(a)(2)(II)(A)	<input type="checkbox"/> 50.73(a)(2)(viii)(A)				
	<input type="checkbox"/> 20.2203(a)(1)	<input type="checkbox"/> 20.2203(a)(4)	<input checked="" type="checkbox"/> 50.73(a)(2)(II)(B)	<input type="checkbox"/> 50.73(a)(2)(viii)(B)				
	<input type="checkbox"/> 20.2203(a)(2)(I)	<input type="checkbox"/> 50.36(c)(1)(I)(A)	<input type="checkbox"/> 50.73(a)(2)(III)	<input type="checkbox"/> 50.73(a)(2)(ix)(A)				
	<input type="checkbox"/> 20.2203(a)(2)(II)	<input type="checkbox"/> 50.36(c)(1)(II)(A)	<input type="checkbox"/> 50.73(a)(2)(IV)(A)	<input type="checkbox"/> 50.73(a)(2)(x)				
	<input type="checkbox"/> 20.2203(a)(2)(III)	<input type="checkbox"/> 50.36(c)(2)	<input type="checkbox"/> 50.73(a)(2)(V)(A)	<input type="checkbox"/> 73.71(a)(4)				
<input type="checkbox"/> 20.2203(a)(2)(IV)	<input type="checkbox"/> 50.46(a)(3)(II)	<input checked="" type="checkbox"/> 50.73(a)(2)(V)(B)	<input type="checkbox"/> 73.71(a)(5)					
<input type="checkbox"/> 20.2203(a)(2)(V)	<input checked="" type="checkbox"/> 50.73(a)(2)(I)(A)	<input type="checkbox"/> 50.73(a)(2)(V)(C)	<input type="checkbox"/> OTHER					
<input type="checkbox"/> 20.2203(a)(2)(VI)	<input type="checkbox"/> 50.73(a)(2)(I)(B)	<input checked="" type="checkbox"/> 50.73(a)(2)(V)(D)	Specify in Abstract below or in NRC Form 366A					

12. LICENSEE CONTACT FOR THIS LER

FACILITY NAME Daniel G. Marks, Section Leader, Regulatory Affairs	TELEPHONE NUMBER (Include Area Code) 623-393-6492
--	--

13. COMPLETE ONE LINE FOR EACH COMPONENT FAILURE DESCRIBED IN THIS REPORT

CAUSE	SYSTEM	COMPONENT	MANUFACTURER	REPORTABLE TO EPIX	CAUSE	SYSTEM	COMPONENT	MANUFACTURER	REPORTABLE TO EPIX
X	EK	DG	C634	Y					

14. SUPPLEMENTAL REPORT EXPECTED <input type="checkbox"/> YES (If yes, complete 15. EXPECTED SUBMISSION DATE) <input checked="" type="checkbox"/> NO	15. EXPECTED SUBMISSION DATE	MONTH	DAY	YEAR

ABSTRACT (Limit to 1400 spaces, i.e., approximately 15 single-spaced typewritten lines)

On October 11, 2005 at 13:33 Mountain Standard Time (MST) Palo Verde Unit 2 and Unit 3 were in Mode 1 (Power Operations), operating at approximately 100 percent power, when Control Room personnel entered LCO 3.0.3.a due to Units 2 & 3 declaring both trains of Emergency Core Cooling (ECCS) and Containment Spray INOPERABLE due to the Refueling Water Tank (RWT) being declared INOPERABLE.

At 16:03 MST on October 11, 2005, Unit 2 initiated a TS required shutdown IAW the requirements of LCO 3.0.3. On October 12, 2005 at 07:06 MST Unit 2 entered MODE 5 and exited LCO 3.0.3.

At 16:55 MST on October 11, 2005, Unit 3 initiated a TS required shutdown IAW the requirements of LCO 3.0.3. On October 12, 2005 at 02:33 MST Unit 3 entered MODE 5 and exited LCO 3.0.3.

In the past three years, Palo Verde reported reactor shutdowns required by Technical Specifications but none associated with this same root cause.

LICENSEE EVENT REPORT (LER)

1. FACILITY NAME	2. DOCKET	6. LER NUMBER			3. PAGE
Palo Verde Nuclear Generating Station Units 2 and 3	05000529	YEAR	SEQUENTIAL NUMBER	REVISION NUMBER	2 OF 8
		2005	-- 005	-- 00	

17. NARRATIVE (If more space is required, use additional copies of NRC Form 366A)

1. REPORTING REQUIREMENT(S):

This LER (50-529/2005-005-00) is being submitted pursuant to 10 CFR 50.73(a)(2)(i)(A), to report the completion of a reactor shutdown required by Technical Specifications. Specifically, on October 12, 2005 Control Room personnel completed reactor shutdowns and cool downs to MODE 5 in Units 2 and 3 to comply with Technical Specification Limiting Condition for Operation (LCO) 3.0.3. LCO 3.0.3.a was entered when Units 2 & 3 declared both trains of Emergency Core Cooling (ECCS) and Containment Spray (CS) INOPERABLE due to the Refueling Water Tank (RWT) being declared INOPERABLE.

On October 16, 2005 Arizona Public Service Engineering concluded that analyses completed by Westinghouse Electric Company and Fauske and Associates Inc. adequately demonstrated that the ECCS and CS could perform their safety functions for their mission times under all postulated accident scenarios. Accordingly, on October 17, 2005 at 17:00 MST PVNGS determined that the RWT was, and had been OPERABLE. In view of the fact that the RWT had not been INOPERABLE, there is no need to address reporting under 10 CFR 50.73(a)(2)(ii)(B), (unanalyzed condition), or 10 CFR 50.73(a)(2)(v)(B) (removal of residual heat) and (D) (mitigate the consequences of an accident), as originally reported in ENS notification number 42050.

2. DESCRIPTION OF STRUCTURE(S), SYSTEM(S) AND COMPONENT(S):

The Safety Injection system (SI) (EIS:BP) is the emergency core cooling system for PVNGS. The SI system consists of three (3) distinct sub-systems:

- Safety injection sub-system, comprised of high pressure safety injection (HPSI) (EIS: BQ), low pressure safety injection (LPSI) (EIS: BP) and the safety injection tanks (SITs) (EIS:BP)
- Shutdown cooling (EIS:BP) sub-system, and
- Containment spray (EIS:BE) sub-system

(The attached simplified diagram below will aid in understanding the SI sub-system.)

LICENSEE EVENT REPORT (LER)

1. FACILITY NAME	2. DOCKET	6. LER NUMBER			3. PAGE
Palo Verde Nuclear Generating Station Units 2 and 3	05000529	YEAR	SEQUENTIAL NUMBER	REVISION NUMBER	3 OF 8
		2005	-- 005	-- 00	

17. NARRATIVE (If more space is required, use additional copies of NRC Form 366A)

The relationship between the systems is that all are used for some phase of plant cooldown on a loss of coolant accident (LOCA). The SI sub-system is the first system to respond to this condition by injecting borated water into the reactor coolant system (RCS) by means of safety injection pumps and/or safety injection tanks. The shutdown cooling sub-system supplements other heat rejection equipment to reduce temperature in post shutdown periods to the refueling temperature (125°F). The containment spray sub-system introduces borated water into the containment atmosphere to reduce containment pressure and temperature in the event of a pipe rupture and removes iodine from the containment atmosphere.

During a loss of coolant, a safety injection actuation signal (SIAS) is generated by low pressurizer pressure and/or high containment pressure. Once activated, the SI system delivers borated water to the reactor coolant system by means of active pumps and/or passive injection tanks. The refueling water tank (RWT) (E1IS:BQ) provides the initial source of water for the SI and CS pumps (injection mode). When the water level in the RWT reaches a low level set point, a recirculation actuation signal (RAS) is generated and the isolation valves for the containment sump suction line open automatically so SI and CS suction can transfer to the containment sump (recirculation mode). The suction isolation valves from the RWT do not automatically close on a RAS but operators are procedurally directed to close them after verifying the suction transfer is complete.

Due to the elevation difference between the RWT and containment sump, water under certain post-accident conditions could continue to drawdown from the RWT following a RAS until plant operators close the RWT suction isolation valves or until such time that the head is balanced between the containment sumps and RWT. This is referred to in this report as the drawdown period.

LICENSEE EVENT REPORT (LER)

1. FACILITY NAME	2. DOCKET	6. LER NUMBER		3. PAGE	
Palo Verde Nuclear Generating Station Units 2 and 3	05000529	YEAR	SEQUENTIAL NUMBER	REVISION NUMBER	4 OF 8
		2005 --	005 --	00	

17. NARRATIVE (If more space is required, use additional copies of NRC Form 366A)

SAFETY INJECTION SYSTEM SIMPLIFIED DIAGRAM

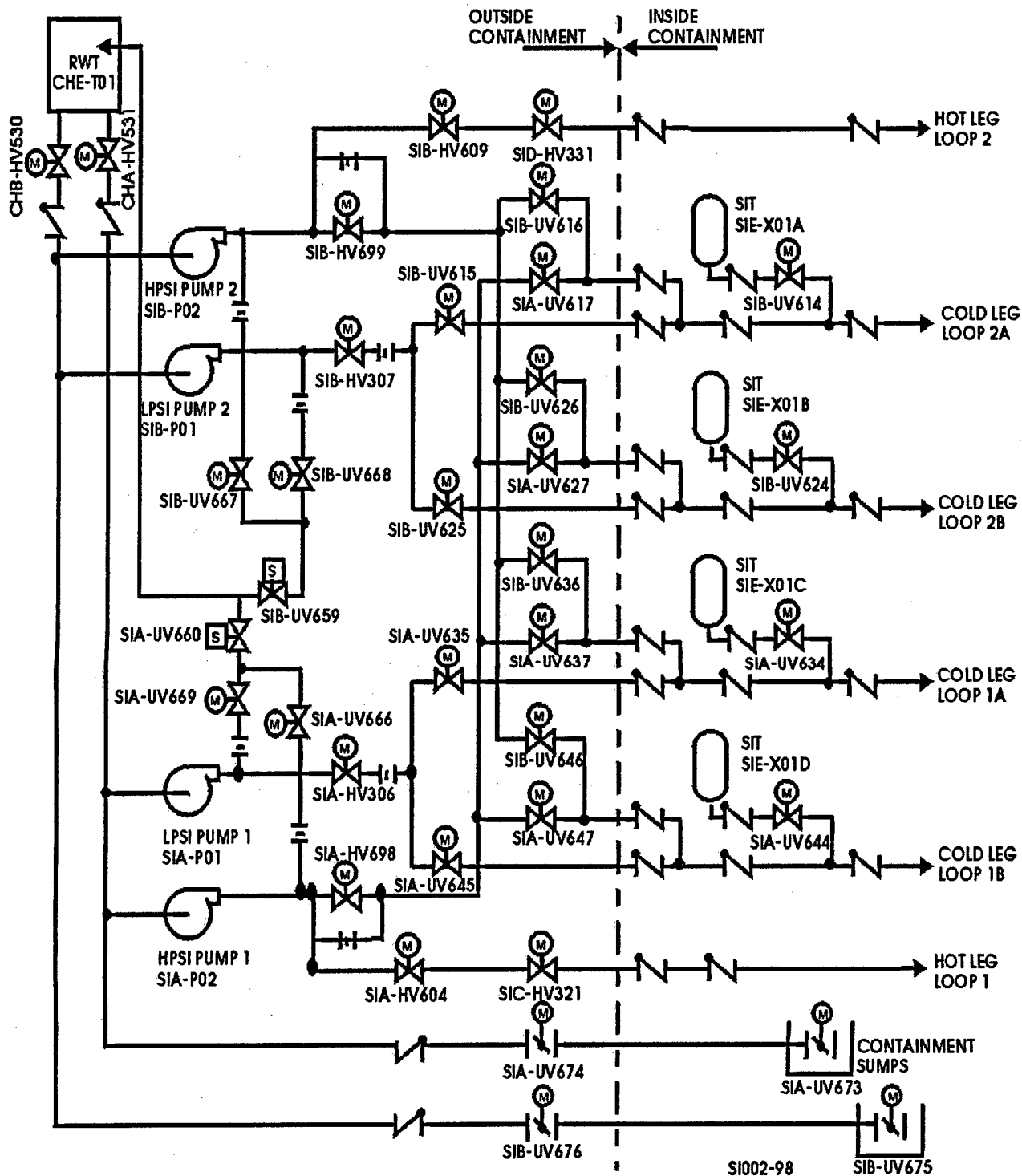

LICENSEE EVENT REPORT (LER)

1. FACILITY NAME	2. DOCKET	6. LER NUMBER			3. PAGE
Palo Verde Nuclear Generating Station Units 2 and 3	05000529	YEAR	SEQUENTIAL NUMBER	REVISION NUMBER	5 OF 8
		2005	-- 005	-- 00	

17. NARRATIVE (If more space is required, use additional copies of NRC Form 366A)

3. INITIAL PLANT CONDITIONS:

On October 11, 2005 Palo Verde Unit 2 and Unit 3 were in Mode 1 (Power Operations), operating at approximately 100 percent power. At the start of the event no other major structures, systems, or components were inoperable that contributed to the event.

4. EVENT DESCRIPTION:

On October 11, 2005 at 13:33 MST Unit 2 and Unit 3 declared both trains of ECCS and Containment Spray INOPERABLE due to the RWT being INOPERABLE, and entered LCO 3.0.3.a. During a Management Review Team (MRT) meeting, Engineering presented information indicating that existing design analyses did not adequately address the possibility of air ingestion into the ECCS and CS pumps during the drawdown period following a RAS. This resulted in the LCO 3.0.3 entry.

PVNGS Units 1, 2, and 3 were constructed in accordance with the Combustion Engineering interface requirements for the System 80 design, as augmented specifically for the Arizona Nuclear Power Project (ANPP). Requirements established for the Safety Injection System specified that the junction of the suction lines from the RWT and the containment sump be placed at an elevation of no less than 16 feet below the minimum containment water level during a LOCA. This requirement was established to ensure that the water level in the RWT suction line would not be reduced below this junction so that air would not be introduced into the ECCS and CS pumps during transfer of the suction from the RWT to the containment sump. Palo Verde implemented this interface requirement in a conservative manner with the actual plant configuration providing almost 40 feet of elevation between the minimum containment water level and the suction line junction.

NRC inspectors questioned the validity of the interface requirement during an extent of condition review conducted during a 95002 inspection (05000528/2005012, 05000529/2005012, and 5000530/2005012). Inspectors challenged the adequacy of the interface requirement to prevent air entrainment during the dynamic conditions of the drawdown period. The inspectors specifically questioned if vortexing, and /or consequential air entrainment could occur if the water level in the RWT were drawn

LICENSEE EVENT REPORT (LER)

1. FACILITY NAME	2. DOCKET	6. LER NUMBER			3. PAGE
Palo Verde Nuclear Generating Station Units 2 and 3	05000529	YEAR	SEQUENTIAL NUMBER	REVISION NUMBER	6 OF 8
		2005	-- 005	-- 00	

17. NARRATIVE (If more space is required, use additional copies of NRC Form 366A)

down below the top of the vortex breaker installed on the end of the suction line inside the RWT.

PVNGS Engineering reviewed the basis for the original Combustion Engineering interface requirement and other supplemental RWT level calculations and concluded that there had been no consideration of dynamic effects during the drawdown period. This information was communicated to the MRT, resulting in the LCO 3.0.3 entry and subsequent unit shutdowns.

The dynamic conditions during the drawdown period were subsequently evaluated by Westinghouse and Fauske and Associates, Inc. to establish the potential for air entrainment. The results of this evaluation are documented in calculation number FAI/05-107, Rev 0. The conclusion of FAI/05-107 is that there would be no degradation of the PVNGS ECCS pump performance during suction transfer from the RWT to the containment sump. However, a mechanistic, quantitative analysis sufficient to support the intent of the original design basis of no entrained air (not including soluble gasses) was not established. PVNGS concluded the Westinghouse/Fauske analysis was suitable for demonstrating operability of the ECCS systems. It provides acceptable technical arguments to support continued operability of the ECCS while a permanent resolution is developed and implemented. On October 17, 2005 at 17:00 MST PVNGS determined that the RWT was, and had been operable. PVNGS Units 2 and 3 were restarted on October 20, 2005.

Technical Specification LCO 3.0.3:

When an LCO is not met and the associated ACTIONS are not met, an associated ACTION is not provided, or if directed by the associated ACTIONS, the unit shall be placed in a MODE or other specified condition in which the LCO is not applicable.

Action shall be initiated within 1 hour to place the unit, as applicable, in:

- a. MODE 3 within 7 hours;
- b. MODE 5 within 37 hours.

Exceptions to this Specification are stated in the individual Specifications.

LICENSEE EVENT REPORT (LER)

1. FACILITY NAME	2. DOCKET	6. LER NUMBER			3. PAGE
Palo Verde Nuclear Generating Station Units 2 and 3	05000529	YEAR	SEQUENTIAL NUMBER	REVISION NUMBER	7 OF 8
		2005	-- 005	-- 00	

17. NARRATIVE (If more space is required, use additional copies of NRC Form 366A)

Where corrective measures are completed that permit operation in accordance with the LCO or ACTIONS, completion of the actions required by LCO 3.0.3 is not required. LCO 3.0.3 is only applicable in MODES 1, 2, 3, and 4.

At 16:03 MST on October 11, 2005, Unit 2 initiated a TS required shutdown IAW the requirements of LCO 3.0.3. On October 12, 2005 at 07:06 MST Unit 2 entered MODE 5 and exited LCO 3.0.3.

At 16:55 MST on October 11, 2005, Unit 3 initiated a TS required shutdown IAW the requirements of LCO 3.0.3. On October 12, 2005 at 02:33 MST Unit 3 entered MODE 5 and exited LCO 3.0.3.

5. ASSESSMENT OF SAFETY CONSEQUENCES:

As described previously, the condition did not prevent the fulfillment of any safety function and did not result in a safety system functional failure as defined by 10 CFR 50.73(a)(2)(v). Accordingly, the event did not result in any challenges to the fission product barriers, nor did it result in the release of radioactive materials. Therefore, there are no adverse safety consequences or implications as a result of this condition. The condition does not adversely affect the safe operation of the plant or health and safety of the public.

The condition did not result in a transient more severe than those analyzed in the updated Final Safety Evaluation Report Chapters 6 and 15. The condition did not have any nuclear safety consequences or personnel safety impact.

6. CAUSE OF THE EVENT:

The cause of Unit 2 and Unit 3 entering TS LCO 3.0.3 and completing the shutdowns was that on October 11, 2005 at approximately 13:33 PM, the Units declared both trains of Emergency Core Cooling (ECCS) and Containment Spray INOPERABLE due to the Refueling Water Tank (RWT) being declared INOPERABLE. This decision was based on Engineering input indicating that existing PVNGS design analyses did not acceptably address the potential for air entrainment in the ECCS suction lines resulting from the

LICENSEE EVENT REPORT (LER)

1. FACILITY NAME	2. DOCKET	6. LER NUMBER			3. PAGE
Palo Verde Nuclear Generating Station Units 2 and 3	05000529	YEAR	SEQUENTIAL NUMBER	REVISION NUMBER	8 OF 8
		2005	-- 005	-- 00	

17. NARRATIVE (If more space is required, use additional copies of NRC Form 366A)

dynamic conditions present in the RWT during the drawdown period immediately following a recirculation actuation signal (RAS). Both Units complied with the TS LCO action statements to shutdown and cooldown the plants.

7. CORRECTIVE ACTIONS:

At 16:03 MST on October 11, 2005, Unit 2 initiated a TS required shutdown IAW the requirements of LCO 3.0.3. On October 12, 2005 at 07:06 MST Unit 2 entered MODE 5 and exited LCO 3.0.3.

At 16:55 MST on October 11, 2005, Unit 3 initiated a TS required shutdown IAW the requirements of LCO 3.0.3. On October 12, 2005 at 02:33 MST Unit 3 entered MODE 5 and exited LCO 3.0.3.

On October 17, 2005 Westinghouse and Fauske and Associates completed calculation number FAI/05-107, Revision 0 demonstrating that there would be no degradation of the PVNGS ECCS pump performance during suction transfer from the RWT to the containment sump.

On November 17, 2005 Westinghouse and Fauske and Associates completed calculation number FAI/05-107, Revision 1 confirming that there would be no degradation of the PVNGS ECCS pump performance during suction transfer from the RWT to the containment sump.

Evaluation, including consideration of associated risks, of prospective actions to affect a permanent resolution to this issue is on-going.

8. PREVIOUS SIMILAR EVENTS:

In the past three years, Palo Verde reported reactor shutdowns required by Technical Specifications but none associated with this same root cause.