



Duratek™

140 Stoneridge Drive
Columbia, South Carolina 29210
803-256-0450 fax 803-256-0968
www.duratekinc.com

71-9196

October 5, 2005
E&L-086-05

Document Control Desk
Director, Spent Fuel Project Office
Office of Nuclear Material Safety and Safeguards, NMSS
U.S. Nuclear Regulatory Commission
Washington, DC 20555

Ref: H. Shamkhani, Duratek, to Director, Spent Fuel Project Office, US NRC, July 15, 2005,
E&L-039-05

Dear Sirs:

SUBJ: SUPPLEMENTAL SUBMITTAL; REQUEST FOR AMENDMENT OF CERTIFICATE OF COMPLIANCE NO. 9196, REV. NO. 21, FOR THE MODEL NO. UX-30 PACKAGE

The referenced application is to allow transport of less than 30" diameter UF₆ cylinders from East Tennessee Technology Park (ETTP) to the Gaseous Diffusion Plant Environmental Restoration Facility (PORTS), located near Portsmouth, OH using UX-30 overpacks. As requested, we are forwarding Ref. 2.3 from that application.

If you have any questions concerning this application, please contact Mr. Charles Witt at (803)758-1890 or crwitt@duratekinc.com.

Sincerely,

Patrick L. Paquin
General Manager, Engineering & Licensing

Attach: "Evaluation of 30" ECV Cylinders Under Various Loading Conditions," ST-499, Rev. 0, July 14, 2005

cc: Mark Allen, BJC
Doc. Control

NMSS01

ATTACHMENT

PROPERTY OF DURATEK INC. AND ITS SUBSIDIARIES

DESIGN DOCUMENT COVER SHEET

DOCUMENT ID NUMBER: ST-499 REVISION NUMBER: 0
PROJECT NUMBER: 5311
SECURITY STATUS: PROPRIETARY: NON-PROPRIETARY: X
RETENTION PERIOD: Life of the Project + 1 Year

TITLE: Evaluation of 30" ECV Cylinders Under Various Loading Conditions

PREPARED BY: *Mr. San Baug* DATE: 07-13-2005

TITLE: Chief Engineer

REVIEWED BY: *Paul D. H.* DATE: 7/14/05

TITLE: Principal Engineer

REVISION NOTES:

--

DOCUMENT CONTROL

Received By: *James D. White* Date: 7/14/05

Document Dated From: 7/13/05 To: 7/14/05

Verification to Index By: *Tala (9-paged)* Date 7/14/05

Storage Shelf Location: DCC

PROPERTY OF DURATEK INC. AND ITS SUBSIDIARIES

DESIGN DOCUMENT REVIEW CHECKLIST

Document ID No.: ST-499 Revision No.: 0

Date: 7/13/2005

ITEM	YES	N/A*
1. The purpose or objective is clear and consistent with the analysis.	√	
2. Design Inputs such as design bases, regulatory requirements, codes, and standards are identified and documented.	√	
3. Effect of design package on compliance with the Safety Analysis Report or Certificate of Compliance identified and documented.	√	
4. References are complete and accurate.	√	
5. Latest version of the drawings is used, and the revision numbers are correct on the list of drawings.	√	
6. Assumptions are reasonable, and the list of assumptions is complete and appropriate.	√	
7. Assumptions that must be verified as the design proceeds have appropriately identified.	√	
8. Analysis methodology is appropriate, and correct analysis method used.	√	
9. Correct values used from drawings?	√	
10. Answers and units correct?	√	
11. Summary of results matches calculations?	√	
12. Material properties properly taken from credible references?	√	
13. Figures match design drawings?	√	
14. Computer input complete and properly identified?	√	
15. Conclusions are consistent with the analysis results.	√	
16. Documentation of all hand calculations attached?	√	
17. Meeting minutes of the Design Review?		√

* Not Applicable, Explain

17. This document presents the analytical evaluation. No design review meeting was needed.

Independent Reviewer



PROPERTY OF DURATEK INC. AND ITS SUBSIDIARIES

DESIGN DOCUMENT REVIEW METHOD CHECKLIST

Document ID No.: ST-499 Revision No.: 0

Date: 7/13/2005

ITEM	
1. Alternate or simplified computational method.	<input type="checkbox"/>
2. Comparison of results to other calculations of a similar nature.	<input type="checkbox"/>
3. Numerical repetition of the calculations.	<input checked="" type="checkbox"/>
4. Comparison of calculations with experimental results.	<input type="checkbox"/>
5. Other (specify)	
6. Comments:	

Independent Reviewer



1.0 OBJECTIVE

To evaluate the 30" ECV cylinders under various loading conditions.

2.0 INTRODUCTION

As a part of the cleanup of the East Tennessee Technology Park (ETTP), cylinders containing varying amount of Uranium hexa-Fluoride (UF_6), will be shipped to Portsmouth, OH for eventual disposition. The ETTP UF_6 cylinders are made of various shapes and sizes. The 30" ECV cylinders (Reference 1) will be used to package less than 30" diameter ETTP UF_6 cylinders. They will be transported using NRC certified UX-30 overpacks (Reference 2). UX-30 overpacks are approved for transporting the ANSI standard UF_6 Model 30B/C cylinders. An application will be made to the US NRC for approval of the 30" ECV cylinders shipment in UX-30 overpacks. In order to support this application it must be demonstrated that the 30" ECV cylinders in UX-30 overpacks provide equivalent safety as Model 30B cylinders in the same overpacks. The 30" ECV cylinders are very close to the ANSI standard 30B cylinders (Reference 3) in dimensions. They have been designed, fabricated, and tested per ASME Section VIII (Reference 4) requirements. It is concluded from comparison that the 30" ECV cylinders, in UX-30 overpack, will perform, same or better than the ANSI 30B/C cylinders in the same overpack. The major difference between the 30" ECV cylinders and ANSI 30B/C cylinders is the closure. The 30" ECV cylinders use a bolted flange closure versus the welded structure of the ANSI 30B/C cylinders. An evaluation of the bolted connection is performed in this document to demonstrate that the design of the closure is capable of maintaining the seal under the most severe hypothetical accident conditions test loading.

3.0 REFERENCES

- (1) Duratek Drawing No. C-067-005311-008, Rev.0, 30 ECV Cylinder.
- (2) Safety Analysis Report for Model UX-30 Package, Revision 4, May 2004, Duratek Inc., Columbia, SC.
- (3) ANSI N14.1-2001, American National Standard for Nuclear Materials – Uranium Hexafluoride – Packaging for Transportation.
- (4) ASME B&PV Code, Sec. VIII.
- (5) Duratek Document ST-489, Rev.0, Comparison of 30B & ETTP 30" Cylinders Under Various Loading Conditions.
- (6) Code of Federal Regulations, Title10, Part 71, 2005 Edition.

4.0 MATERIAL PROPERTIES

None used in this document.

5.0 ALLOWABLE STRESSES & STRAINS

Evaluation performed with comparison.

6.0 EVALUATION DETAILS

30ECV & 30B/C Cylinder Package Comparison

Similar Features

- Both 30ECV and 30B/C Cylinders are shipped inside a UX-30 Overpack
- Similar Overall Dimensions

Quantity	30ECV	30B/C
Length	81.5 inch	81.5 inch
Body Diameter	30 inch	30 inch
Shell Diameter	20 inch	30 inch
Shell Thickness	½ inch	½ inch

- Both are constructed from the same material – SA 516 Gr. 70
- Both are designed for 200 psig, and hydrostatically tested to 400 psig
- Both are designed, fabricated, tested, and stamped per ASME Code, Section VIII

Superior Features

- Smaller 30" ECV weight – 4,000 lb versus 6,620 lb
- 2" thick baseplate versus ½" semi elliptical head
- 2" thick flange/lid versus ½" semi elliptical head

Title Evaluation of 30" ECV Cylinders Under Various Loading Conditions

Calc. No. ST-499

Rev. 0

Sheet 3 of 6

- 30ECV packages do not have valves, eliminating the most vulnerable component of the package during the HAC tests
- Gasket seal between the flange and lid of the ECV cylinders
- 30ECV lid secured by 20 1 1/8" bolts, torqued to 400 ft-lb, providing ample bolt pretension and gasket compression

Additional Features

- Recessed lid - provides protection against a direct impact during HAC events
- Cushioning material around the shell - provides uniform load distribution between the 30ECV vessel and the UX-30 Overpack
- Dunnage material inside the cavity – reduces the payload inertia during HAC, provides uniform load distribution between the payload and the 30ECV cylinders
- 30ECV controlled shipment – made under ETTP transportation plan versus the general shipment of the 30B/C cylinders – limits the likelihood and severity of the potential accidents.

Based on the above comparison, it can be concluded that the overall behavior of the 30" ECV cylinders in UX-30 will be same or superior to the 30B/C cylinders in the same overpack.

The main difference between the two types of cylinders is in their closure arrangement. Whereas the 30B/C cylinders have a welded structure, 30" ECV cylinder uses a bolted flange connection. This connection will be tested to 400 psig internal pressure. The successful testing will qualify the cylinder for the internal pressure-loading requirement. Under the normal conditions of transport and hypothetical accident conditions loading, the most severe loading on the bolted connection arises under a corner drop. The inertia of the lid and the payload is reacted by the bolts in a loading pattern as shown in Figure 1. The analysis performed in the following section shows that the bolted connection will maintain its sealing under a deceleration loading several times larger than the one expected during the HAC test.

Derivation of the Bolt Load Distribution

Consider the load distribution shown in Figure 1 below.

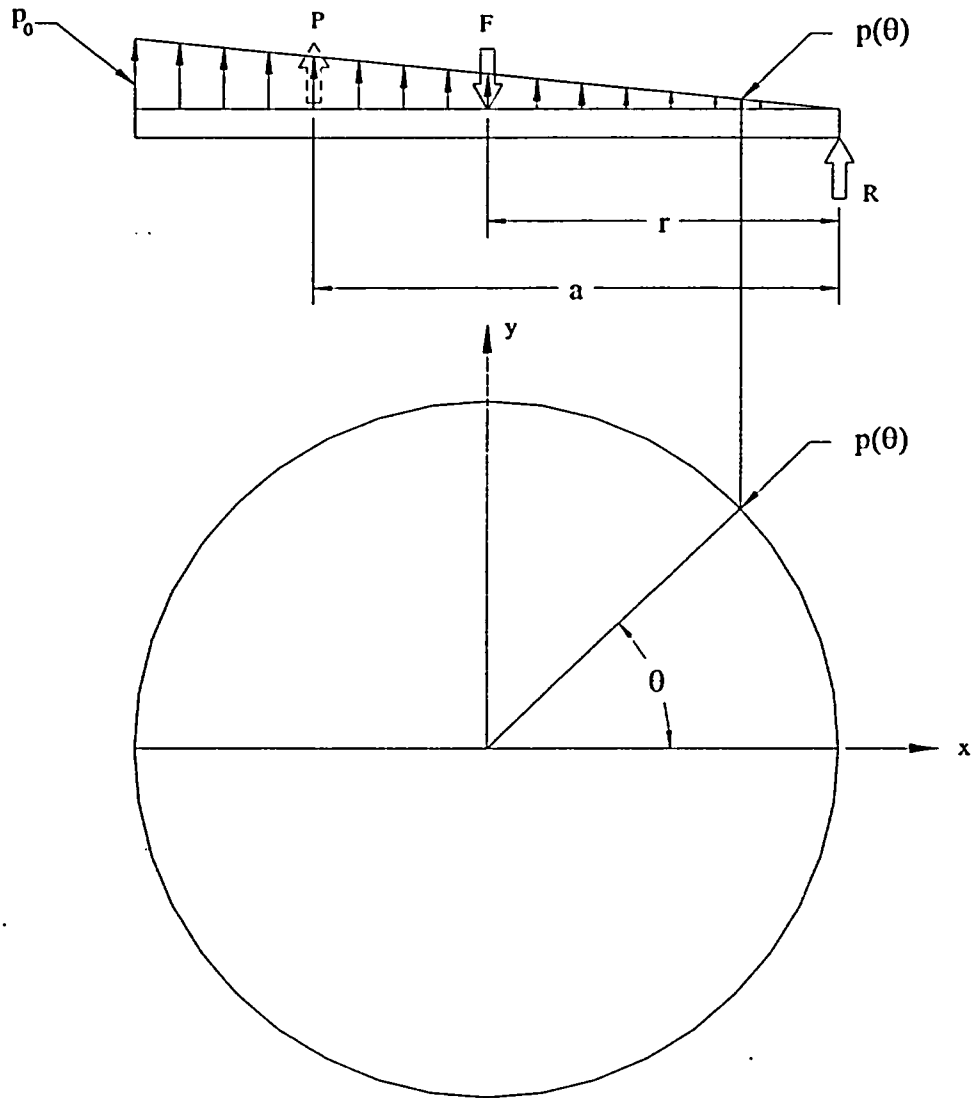

Figure 1
Lid Bolt Force Distribution

$$p(\theta) = \frac{p_0}{2} (1 - \cos \theta)$$

$$P = \int_0^{2\pi} p(\theta) r d\theta$$

$$= \int_0^{2\pi} \frac{p_0 r}{2} (1 - \cos \theta) d\theta$$

$$= \frac{p_0 r}{2} \int_0^{2\pi} (1 - \cos \theta) d\theta$$

$$= \frac{p_0 r}{2} \left[\theta - \sin \theta \right]_0^{2\pi}$$

$$= \pi r p_0$$

$$M = \int_0^{2\pi} p(\theta) r (1 - \cos \theta) r d\theta$$

$$= \frac{p_0 r^2}{2} \int_0^{2\pi} (1 - \cos \theta)^2 d\theta$$

$$= \frac{p_0 r^2}{2} \int_0^{2\pi} (1 - 2 \cos \theta + \cos^2 \theta) d\theta$$

$$= \frac{p_0 r^2}{2} \int_0^{2\pi} \left[1 - 2 \cos \theta + \frac{1}{2} (1 + \cos 2\theta) \right] d\theta$$

$$= \frac{p_0 r^2}{2} \int_0^{2\pi} \left[\frac{3}{2} - 2 \cos \theta + \frac{1}{2} \cos 2\theta \right] d\theta$$

$$= \frac{p_0 r^2}{2} \left[\frac{3}{2} \theta - 2 \sin \theta + \frac{1}{4} \sin 2\theta \right]_0^{2\pi}$$

$$= \frac{p_0 r^2}{2} \times 3\pi$$

$$= \frac{3}{2} \pi r^2 p_0$$

$$M = F \times r$$

$$F = \frac{M}{r} = \frac{3}{2} \pi r p_0 = \frac{3}{2} P$$

$$p_0 = \frac{2}{3} \frac{F}{\pi r}$$

$$a = \frac{F}{P} \times r$$

$$= \frac{\frac{3}{2} \pi r p_0}{\pi r p_0} \times r$$

$$= \frac{3}{2} r$$

$$R = F - P$$

$$= \frac{3}{2} \pi r p_0 - \pi r p_0$$

$$= \frac{1}{2} \pi r p_0$$

$$= \frac{1}{2} P$$

$$F = \frac{3}{2} P$$

$$P = \frac{2}{3} F$$

$$R = \frac{1}{3} F$$

If the number of bolts = N,

Each bolt carries the load corresponding a bolt circle length of $2 \times \pi \times r / N$.

The maximum bolt load is, therefore,

$$F_{\text{bolt}} = 2 \times \pi \times r \times p_0 / N$$

Maximum Payload = 1,600 lb

$$\text{Lid Mass} = \pi/4 \times 28.5^2 \times 2 \times 0.283 = 361 \text{ lb}$$

$$\text{Payload} + \text{Lid} = 1,600 + 361 = 1,961 \text{ lb, say } 2,000 \text{ lb}$$

$$\text{Number of Bolts} = 20$$

$$\text{Bolt Circle Radius} = 12.5 \text{ in}$$

For an assumed deceleration of the cylinder of 100g,

$$F = 100 \times 2,000 = 200,000 \text{ lb}$$

$$p_0 = 2F/(3\pi r) = 2 \times 200,000 / (3 \times \pi \times 12.5) = 3,395.3 \text{ lb/in}$$

The maximum bolt load,

$$F_{\text{bolt}} = 2 \times \pi \times r \times p_0 / N = 2 \times \pi \times 12.5 \times 3,395.3 / 20 = 13,333 \text{ lb}$$

The 30" ECV Cylinders have been designed to an internal pressure of 200 psig. Under this pressure the bolts are subjected to a load of:

$$F_{\text{press}} = \pi/4 \times 19^2 \times 200 / 20 = 2,835 \text{ lb}$$

The bolts (nominal diameter 1 1/8") are torqued to 400 ft-lb in lubricated state. In the bolts, this creates a preload of:

$$F_{\text{preload}} = 12 \times 400 / (0.1 \times 1.125) = 42,667 \text{ lb}$$

Subtracting the bolt load due to internal pressure of 200 psig, i.e. 2,835 lb from this load, 42,667-2,835 = 39,832 lb force in each bolt is available to resist the inertia load from the payload and the mass of the lid. This corresponds to a package deceleration of,

$$d = 39,832 / 13,333 \times 100 = 298.7 \text{ g}$$

The package consisting of a 30" ECV cylinder and a UX-30 overpack is comparable to packages consisting of 30B/C cylinders in UX-30 overpack. It has been shown in Reference 5 that such a package develops stresses in the cylinder close to the allowable value when subjected to a deceleration load of 100g. Therefore, it is concluded that the 30" ECV cylinders will maintain their sealing under a deceleration loading several times larger than the one expected during the HAC test.

7.0 CONCLUSIONS

It has been shown by comparison and supplemental analyses that the 30" ECV cylinders in UX-30 overpack meet the structural requirements of 10 CFR 71 (reference 6).