



September 27, 2005

L-MT-05-088  
10 CFR 50.55a(g)(5)(iii)

U.S. Nuclear Regulatory Commission  
Attn: Document Control Desk  
Washington, DC 20555

Monticello Nuclear Generating Plant  
Docket 50-263  
License No. DPR-22

10 CFR 50.55a Request No. 13: Relief from Impractical Examination Coverage Requirements Pursuant to 10 CFR 50.55a(g)(5)(iii) for the Fourth Ten-Year Inservice Inspection Interval

Pursuant to 10 CFR 50.55a(g)(5)(iii), the Nuclear Management Company, LLC requests relief from certain examination coverage requirements imposed by the American Society of Mechanical Engineers Boiler and Pressure Vessel Code, Section XI, "Rules for Inservice Inspection of Nuclear Power Plant Components," for the Monticello Nuclear Generating Plant (MNGP).

This 10 CFR 50.55a request is for weld examinations, performed during the 2005 refueling outage, where the required coverage of "essentially 100 percent" could not be obtained when examined to the extent practical. The basis for the 10 CFR 50.55a request is that compliance with the specified requirements is impractical due to plant design.

MNGP is submitting this request for the Fourth Ten-Year Inservice Inspection Interval scheduled to end on May 31, 2012.

This letter contains no new commitments and makes no revisions to existing commitments.

John T. Conway  
Site Vice President, Monticello Nuclear Generating Plant  
Nuclear Management Company, LLC

Enclosures (3)

cc: Administrator, Region III, USNRC  
Project Manager, Monticello, USNRC  
Resident Inspector, Monticello, USNRC  
Minnesota Department of Commerce (Attn: L. Brandon)

A047

**ENCLOSURE 1**  
**10 CFR 50.55a REQUEST NO. 13**  
**IN ACCORDANCE WITH 10 CFR 50.55a(g)(5)(iii)**  
**INSERVICE INSPECTION IMPRACTICALITY**

**1. ASME Code Component(s) Affected**

Components affected are American Society of Mechanical Engineers (ASME) Boiler and Pressure Vessel Code (Code), Section XI, Class 1, Reactor Vessel Nozzle-to-Vessel Shell welds specified below and in-detail in Table A:

Recirculation Suction	Nozzle N-1A	Weld - N-1A NV
Recirculation Inlet	Nozzle N-2D	Weld - N-2D NV
Recirculation Inlet	Nozzle N-2E	Weld - N-2E NV
Recirculation Inlet	Nozzle N-2J	Weld - N-2J NV
Main Steam Discharge	Nozzle N-3A	Weld - N-3A NV
Feedwater Inlet	Nozzle N-4C	Weld - N-4C NV
Core Spray Inlet	Nozzle N-5B	Weld - N-5B NV
Jet Pump Instrumentation	Nozzle N-8A	Weld - N-8A NV

**2. Applicable ASME Section XI Code Edition and Addenda**

The applicable ASME Section XI Code for the Monticello Nuclear Generating Plant (MNGP), Fourth Ten-Year Inservice Inspection (ISI) Interval is the 1995 Edition with the 1996 Addenda.

**3. Applicable Code Requirement**

ASME Class 1 Nozzle-to-Vessel Shell welds are subject to the examination requirements of Subsection IWB Table IWB-2500-1, as shown below, and are required to be examined once within the Fourth Ten-Year Interval:

Code Class: 1  
References: IWB-2500, Table IWB-2500-1  
Examination Category: B-D  
Item Number: B3.90  
Description: Nozzle-to-Vessel Shell Welds  
Component Numbers: See Section 1 and Table A  
System: Reactor Vessel  
Examination Method: Volumetric – Ultrasonic Testing (UT)

In lieu of the examination volume depicted in Figure IWB-2500-7(b), the United States Nuclear Regulatory Commission (NRC) has authorized the NMC to use the alternative examination volume requirements of Code Case N-613-1 (Reference 1) for the Nozzle-to-Vessel Shell welds listed in this request.

**ENCLOSURE 1**  
**10 CFR 50.55a REQUEST NO. 13**  
**IN ACCORDANCE WITH 10 CFR 50.55a(g)(5)(iii)**  
**INSERVICE INSPECTION IMPRACTICALITY**

The MNGP Fourth Ten-Year Interval Inservice Inspection Plan also implements Code Case N-460 (Reference 2), which is endorsed by the NRC in Regulatory Guide 1.147 (Reference 3). Code Case N-460 states in part, "when the entire examination volume or area cannot be examined due to interference by another component or part geometry, a reduction in examination coverage on any Class 1 or Class 2 weld may be accepted provided the reduction in coverage for that weld is less than 10 percent."

NRC Information Notice (IN) 98-42 (Reference 4) termed a reduction in coverage of less than 10 percent to be "essentially 100 percent." IN 98-42 states in part, 'The NRC has adopted and further refined the definition of "essentially 100 percent" to mean "greater than 90 percent"...has been applied to all examinations of welds or other areas required by ASME Section XI.'

**4. Impracticality of Compliance**

Construction Permit CPPR-31 was obtained for the MNGP in 1967. The MNGP systems and components were designed and fabricated before the examination requirements of ASME Section XI were formalized and published. Because this plant was not specifically designed to meet the requirements of ASME Section XI, full compliance is not feasible or practical within the limits of the current plant design.

10 CFR 50.55a recognizes the limitations to in-service inspection of components in accordance with Section XI of the ASME Code, that are imposed due to early plants' design and construction, as follows:

10 CFR 50.55a(g)(1): For a boiling or pressurized water-cooled nuclear power facility whose construction permit was issued prior to January 1, 1971, components (including supports) must meet the requirements of paragraphs (g) (4) and (5) of this section to the extent practical.

10 CFR 50.55a(g)(4): Throughout the service life of a boiling or pressurized water-cooled nuclear power facility, components (including supports) which are classified as ASME Code Class 1, Class 2, and Class 3 must meet the requirements, except design and access provisions and pre-service examination requirements, set forth in Section XI of editions of the ASME Boiler and Pressure Vessel Code ... to the extent practical within the limitations of design, geometry and materials of construction of the components.

**ENCLOSURE 1**  
**10 CFR 50.55a REQUEST NO. 13**  
**IN ACCORDANCE WITH 10 CFR 50.55a(g)(5)(iii)**  
**INSERVICE INSPECTION IMPRACTICALITY**

10 CFR 50.55a(g)(5)(iii): If the licensee has determined that conformance with certain code requirements is impractical for its facility, the licensee shall notify the Commission and submit, as specified in § 50.4, information to support the determinations.

The inspection limitations on the subject components are primarily due to inherent nozzle design geometric contours with some additional, minor interference from nearby welded attachments (see Table A).

A description of the examination methodology used to provide the maximum obtainable coverage is provided in Section 6 of this request. This methodology is based on ASME Section XI, Appendix VIII qualification and was applied to the extent practical within the design constraints of the components. Enclosure 3 provides cross-sectional diagrams of the subject welds showing the geometric contour of the component design in relation to the welds and the coverage obtained within the examination volume requirements of Code Case N-613-1, Figure 2.

**5. Burden Caused by Compliance**

Compliance with the examination coverage requirements of ASME Section XI would require modification, redesign, or replacement of components where geometry is inherent to the component design.

**6. Proposed Alternative and Basis for Use**

**Proposed Alternative**

In accordance with 10 CFR 50.55a(g)(5)(iii), relief is requested for the components listed in Table A on the basis that the required examination coverage of "essentially 100 percent" is impractical due to physical obstructions and the limitations imposed by design, geometry and materials of construction.

NMC performed qualified examinations that achieved the maximum, practical amount of coverage obtainable within the limitations imposed by the design of the components. Additionally, as Class 1 examination Category B-P components, a VT-2 examination is performed on the subject components of the Reactor Coolant Pressure Boundary during system pressure tests each refueling outage. This was completed during the 2005 refueling outage and no evidence of leakage was identified for these components.

**ENCLOSURE 1**  
**10 CFR 50.55a REQUEST NO. 13**  
**IN ACCORDANCE WITH 10 CFR 50.55a(g)(5)(iii)**  
**INSERVICE INSPECTION IMPRACTICALITY**

Therefore, pursuant to 10 CFR 50.55a(g)(5)(iii), NMC requests relief from the requirements of ASME Section XI Table IWB-2500-1, Category B-D, Item B3.90 and associated Code Cases, and proposes to utilize these completed exams as an acceptable alternative that provides reasonable assurance of continued structural integrity.

Basis For Use

The MNGP Nondestructive Examination (NDE) procedures incorporate improved inspection techniques qualified under Appendix VIII of the ASME Section XI Code by the Performance Demonstration Initiative (PDI) for examination of the subject nozzle-to-shell welds.

Coverage was obtained by following the scan parameters defined by the MNGP specific Electric Power Research Institute (EPRI) computer modeling report (Reference 5) for each nozzle configuration and angle, and as designated within MNGP NDE procedures.

The examinations were performed using a manual contact method from the nozzle outside blend and vessel shell surfaces as discussed in the EPRI modeling report and as stated in MNGP procedures. The shear wave mode of propagation was used for each of the transducer and wedge combinations required for the inner 15 percent of the required parallel scan volume. The refracted longitudinal wave mode of propagation was used for the remaining outer 85 percent of the volume for parallel scans, and all of the perpendicular scans.

The subject components received the required examination(s) to the extent practical within the limited access of the component design. For the examinations conducted, satisfactory results were achieved, and no evidence of unacceptable flaws were detected with the improved inspection techniques.

Due to the design of these welds it was not feasible to effectively perform a volumetric examination of 100 percent of the volume as described in IWB-2500-7(b). The nozzle-to-vessel welds are accessible from the vessel shell side of the weld, but examinations cannot be performed from the nozzle side of the weld because of the forging curvature. In addition, due to component configuration, certain nozzle-to-vessel weld examinations are further limited by the reactor pressure vessel design obstructions (such as appurtenances).

Additional coverage for the limited areas was not achievable or practical, based on the latest qualified ultrasonic technology, nor by other considered examinations methods, such as radiography. MNGP has concluded that if

**ENCLOSURE 1**  
**10 CFR 50.55a REQUEST NO. 13**  
**IN ACCORDANCE WITH 10 CFR 50.55a(g)(5)(iii)**  
**INSERVICE INSPECTION IMPRACTICALITY**

significant degradation existed in the subject welds, it should have been identified by the examinations performed.

Additionally, as Class 1 examination category B-P components, VT-2 examinations were performed on the subject components in association with the Reactor Coolant Pressure Boundary system pressure test performed during the 2005 refueling outage, and no evidence of leakage was identified.

The materials for the subject components are A533 Cl I nozzle forgings welded to A508 Cl II vessel shell plate. A review of operating experience within the nuclear industry did not reveal any instances of cracking in this location and type of weldment.

The MNGP reactor vessel water chemistry is controlled in accordance with the 2004 revision to the BWR Water Chemistry Guidelines (Reference 6). Also a hydrogen water chemistry system is used to reduce the oxidizing environment in the reactor coolant. These additional measures provide added assurance against the initiation of cracking or corrosion from the inside surface of the reactor vessel for the subject components listed in this request. An inerted primary containment environment during operation provides assurance of corrosion protection on the outside surface of the reactor vessel.

Based on the above, with due consideration of the earlier plant design, the underlying objectives of the Code required volumetric examinations have been met. The examinations were completed to the extent practical and evidenced no unacceptable flaws present. VT-2 examinations performed on the subject components during system pressure testing each refueling outage (in accordance with examination Category B-P) provide continued assurance that the structural integrity of the subject components is maintained. Additionally, the MNGP Water Chemistry Program and inerted primary containment environment provide added measures of protection for the component materials.

**7. Duration of Proposed Alternative**

NMC requests the granting of this relief for the Fourth Ten-Year Inservice Inspection Interval of the Inservice Inspection Program for the MNGP that is scheduled to end on May 31, 2012.

**8. Precedents**

The NRC has granted relief for the MNGP for previous ten-year inservice inspection intervals, most recently the Third Ten-Year Inservice Inspection Interval (Reference 7). Also, the NRC has granted relief for the Quad Cities Nuclear Power Station, Units 1 and 2 (Reference 8), the Dresden Nuclear Power

**ENCLOSURE 1**  
**10 CFR 50.55a REQUEST NO. 13**  
**IN ACCORDANCE WITH 10 CFR 50.55a(g)(5)(iii)**  
**INSERVICE INSPECTION IMPRACTICALITY**

Station, Units 2 and 3 (Reference 9), and the Prairie Island Nuclear Generating Plant, Unit 2 (Reference 10).

---

**REFERENCES**

1. ASME Section XI Code Case N-613-1, "Ultrasonic Examination of Full Penetration Nozzles in Vessels, Examination Category B-D, Item No's. B3.10 and B3.90, Reactor Nozzle-To-Vessel Welds, Figures IWB-2500-7(a), (b), and (c)."
2. ASME Section XI Code Case N-460, "Alternative Examination Coverage for Class 1 and Class 2 Welds."
3. Regulatory Guide 1.147, "Inservice Inspection Code Case Acceptability, ASME Section XI, Division 1," Revision 13, January 2004.
4. NRC Information Notice 98-42, "Implementation of 10 CFR 50.55a(g) In-service Inspection Requirements."
5. EPRI Internal Report IR-2004-63, "Monticello Nozzle Inner Radius and Nozzle-to-Shell Weld Examinations."
6. BWRVIP-130, "BWR Water Chemistry Guidelines – 2004 Revision" (EPRI Topical Report TR-1008192).
7. NRC letter to NMC, "Monticello Nuclear Generating Plant Third 10-Year Interval Inservice Inspection Relief Request No. 16, Parts A, B and C (TAC No. MB5487)," dated May 19, 2003.
8. Letter from NRC to Commonwealth Edison Company, "Quad Cities, Units 1 and 2 - Relief Request CR-32 for Third 10-Year Inservice Inspection Interval," dated September 6, 2000.
9. Letter from NRC to Exelon Generation Company, LLC, "Dresden Nuclear Power Station, Units 2 and 3 - Relief Request CR-24 For Third 10-Year Inservice Inspection Interval," dated January 8, 2003.
10. NRC letter to NMC, "Prairie Island Nuclear Generating Plant, Unit 2 – Evaluation of Relief Request No. 16 for the Unit 2 3<sup>rd</sup> 10-year Interval Inservice Inspection Program (TAC No. MC1775)," dated October 18, 2004.

**ENCLOSURE 2**  
**10 CFR 50.55a REQUEST NO. 13**  
**IN ACCORDANCE WITH 10 CFR 50.55a(g)(5)(iii)**  
**INSERVICE INSPECTION IMPRACTICALITY**

**TABLE A - Category B-D, "Full Penetration Welds of Nozzles in Vessels," Item No. B3.90**  
**Percent Coverage and Limitations for Nozzles N-1A, N-2D, N-2E, N-2J, N-3A, N-4C, N-5B, and N-8A**

Code Category and Item No.	System and Component Description	Component ID	Code Component and Examination Volume Required	Percent* Coverage Obtained	Limitations	Exam Report Number
B-D B3.90	Reactor Vessel, Recirculation Suction Nozzle N-1A	N-1A NV	Nozzle-to-Vessel Weld, Code Case N-613-1 Figure 2	83%	Limited due to nozzle configuration. Also, small reduction due to interference from welded thermocouple attachments.	2005UT041
B-D B3.90	Reactor Vessel, Recirculation Inlet Nozzle N-2D	N-2D NV	Nozzle-to-Vessel Weld, Code Case N-613-1 Figure 2	82%	Limited due to nozzle configuration. Also, small reduction due to interference from welded thermocouple attachment.	2005UT028
B-D B3.90	Reactor Vessel, Recirculation Inlet Nozzle N-2E	N-2E NV	Nozzle-to-Vessel Weld, Code Case N-613-1 Figure 2	78%	Limited due to nozzle configuration.	2005UT016
B-D B3.90	Reactor Vessel, Recirculation Inlet Nozzle N-2J	N-2J NV	Nozzle-to-Vessel Weld, Code Case N-613-1 Figure 2	78%	Limited due to nozzle configuration.	2005UT005
B-D B3.90	Reactor Vessel, Main Steam Discharge Nozzle N-3A	N-3A NV	Nozzle-to-Vessel Weld, Code Case N-613-1 Figure 2	83%	Limited due to nozzle configuration.	2005UT023
B-D B3.90	Reactor Vessel, Feedwater Inlet Nozzle N-4C	N-4C NV	Nozzle-to-Vessel Weld, Code Case N-613-1 Figure 2	79%	Limited due to nozzle configuration.	2005UT025



**ENCLOSURE 2**  
**10 CFR 50.55a REQUEST NO. 13**  
**IN ACCORDANCE WITH 10 CFR 50.55a(g)(5)(iii)**  
**INSERVICE INSPECTION IMPRACTICALITY**

Code Category and Item No.	System and Component Description	Component ID	Code Component and Examination Volume Required	Percent* Coverage Obtained	Limitations	Exam Report Number
B-D B3.90	Reactor Vessel, Core Spray Inlet Nozzle N-5B	N-5B NV	Nozzle-to-Vessel Weld, Code Case N-613-1 Figure 2	81%	Limited due to nozzle configuration. Also, small reduction due to interference from welded thermocouple attachments.	2005UT018
B-D B3.90	Reactor Vessel, Jet Pump Instrumentation Nozzle N-8A	N-8A NV	Nozzle-to-Vessel Weld, Code Case N-613-1 Figure 2	83%	Limited due to nozzle configuration.	2005UT037

\* Due to the nozzle design it was not feasible to effectively examine essentially 100 percent of the required examination volume as defined in Figure 2 of Code Case N-613-1. Percentages are conservatively rounded down to the nearest whole number. It should be noted that 100 percent of the inner 15 percent was examined in the parallel scans for all components listed above.

## ENCLOSURE 3

### 10 CFR 50.55a REQUEST NO. 13 IN ACCORDANCE WITH 10 CFR 50.55a(g)(5)(iii) INSERVICE INSPECTION IMPRACTICALITY

#### EXAM LIMITATIONS IMPOSED BY COMPONENT DESIGN AND CONSTRUCTION

This enclosure contains a series of excerpts from the ISI Ultrasonic Testing (UT) reports applicable to the subject components.

These excerpts contain sketches depicting the component configuration with physical limitations imposed by the design, e.g., geometrical contour, weld position, interferences, and a cross sectional view depicting the UT coverage and limitations in relation to the required examination volume.

Also included is a sketch of a typical nozzle contour and the resulting affect that causes the UT transducer to lose coupling contact when it reaches the nozzle blend radius.

COMPONENT	REPORT	PAGE(S)
N-1A NV	2005UT041	Pages 1-3
N-2D NV	2005UT028	Pages 4-5
N-2E NV	2005UT016	Pages 6-7
N-2J NV	2005UT005	Pages 8-9
N-3A NV	2005UT023	Page 10
N-4C NV	2005UT025	Pages 11-12
N-5B NV	2005UT018	Pages 13-14
N-8A NV	2005UT037	Page 15
Typical Nozzle Contour Affecting Transducer Contact		Page 16

16 Pages Follow

# Coverage drawings excerpted from applicable reports

Component – N-1A NV Report # 2005UT041



## Supplemental Report

Report No.: 2005UT041

Summary No.: 102652

Comments: Parallel scan limitation due to radius area, no contact  
Axial scan limitation due to transducer size and radius area, no contact.

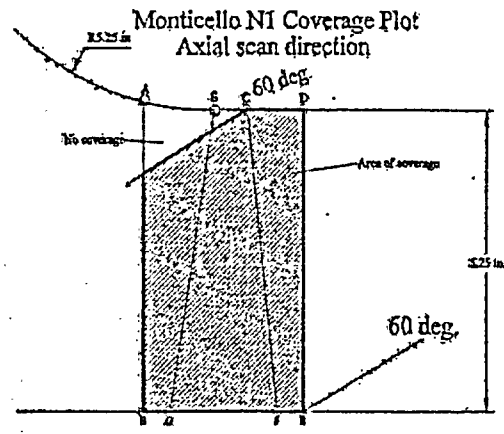
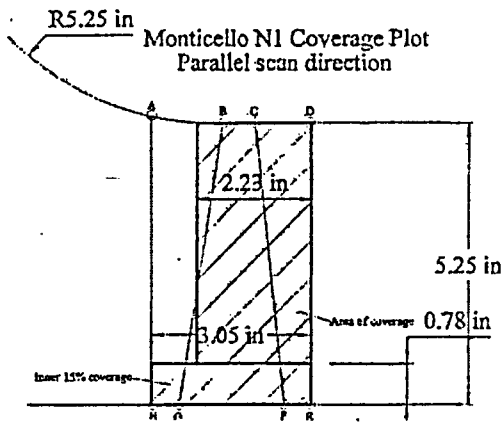

Component – N-1A NV Report # 2005UT041



Limitation Record

Summary No.: 102652

Report No.: 2005UT041

Description of Limitation:

4" Limitation due to thermo-couple.

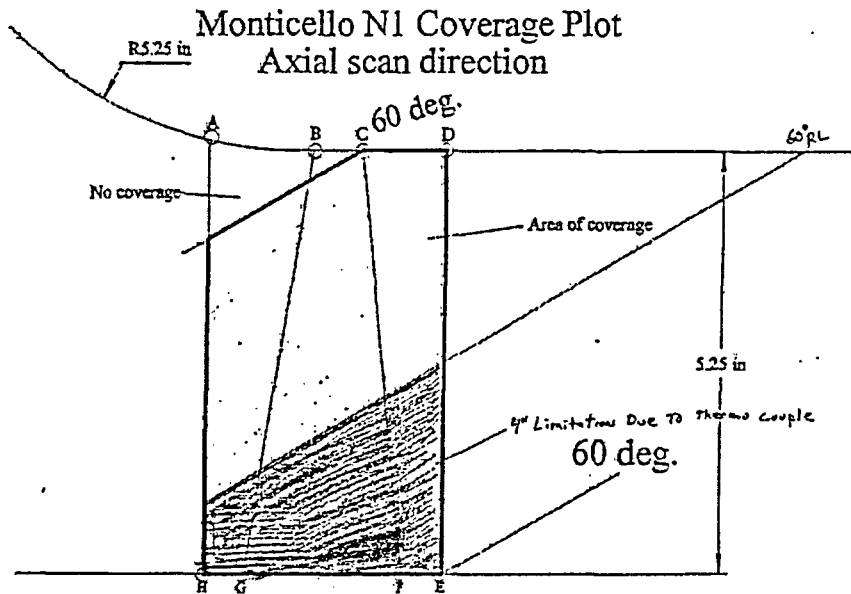



Supplemental Report

Report No.: 2005UT041

Summary No.: 102652

---

Comments: 4" Limitation due to thermo-couple at 18 1/2" counter clockwise.

NOZZLE TO VESSEL WELD

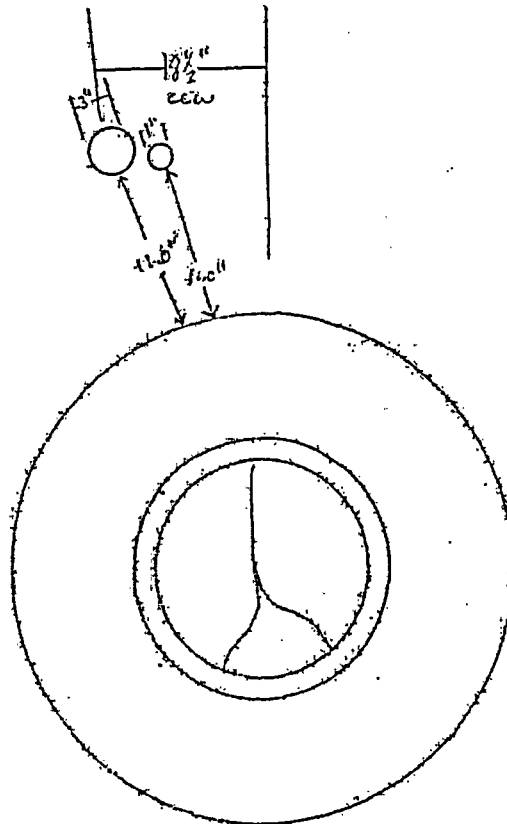

Component – N-2D NV Report # 2005UT028



Supplemental Report

Report No.: 2005UT028

Summary No.: 102662

- Comments: Monticello N2D Coverage plots.
- Axial scan limitation due to transducer size and radius area, no contact.
  - Parallel scan limitation due to radius area, no contact.

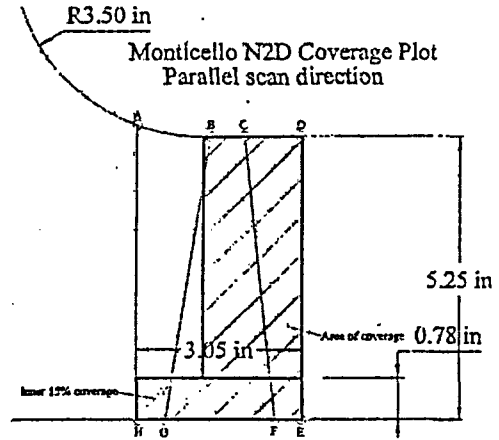
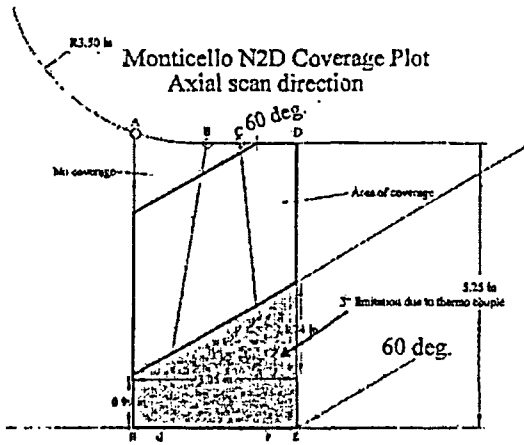

Component – N-2D NV Report # 2005UT028



Supplemental Report

Report No.: 2005UT028

Summary No.: 102662

---

Comments: 3" Limitation due to thermo-couple at 79° clockwise.

N2D Nozzle to Vessel Weld

Limitation Sketch

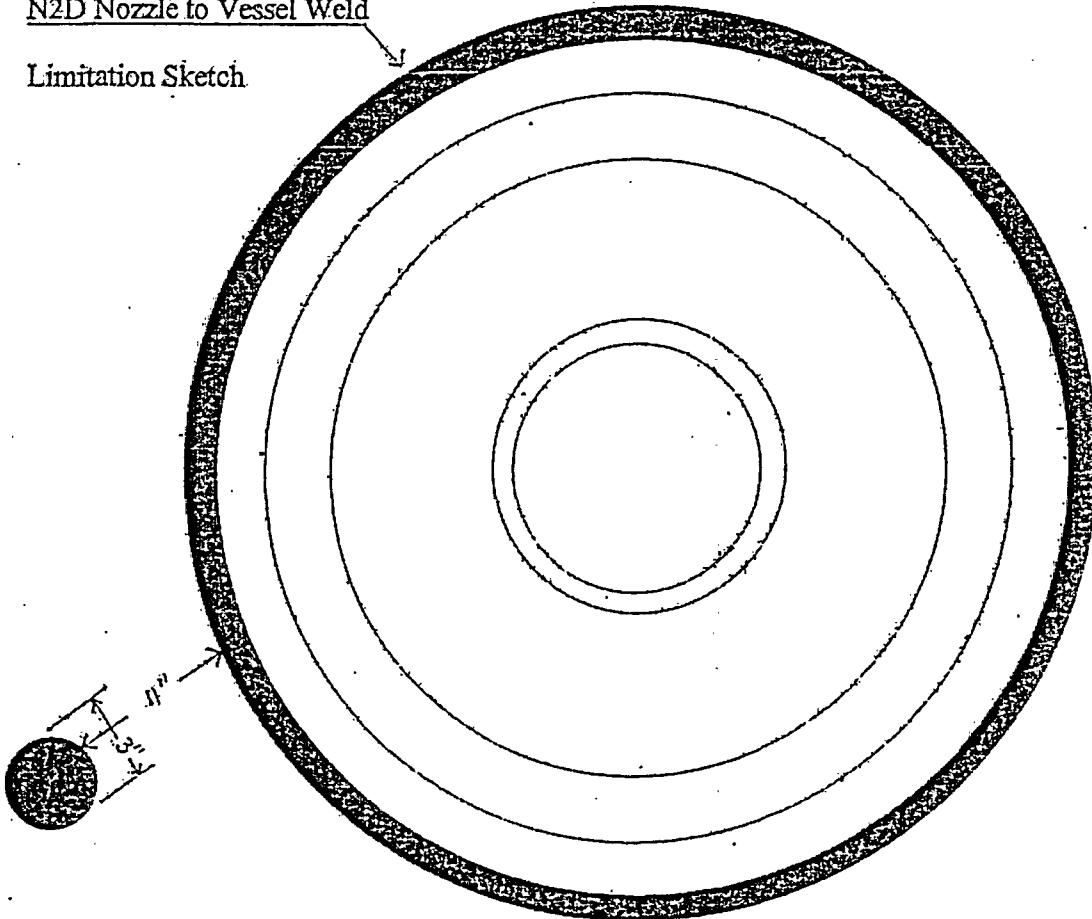

Component – N-2E NV Report # 2005UT016



Supplemental Report

Report No.: 2005UT016

Summary No.: 102664

Comments: Limitation due to radius area, no contact.

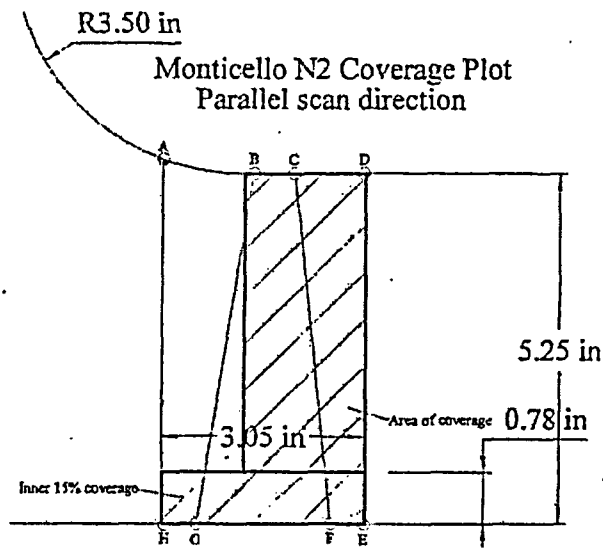



Component – N-2E NV Report # 2005UT016

Supplemental Report

Report No.: 2005UT016



Summary No.: 102664

Comments: Limitation due to transducer size and radius area, no contact.

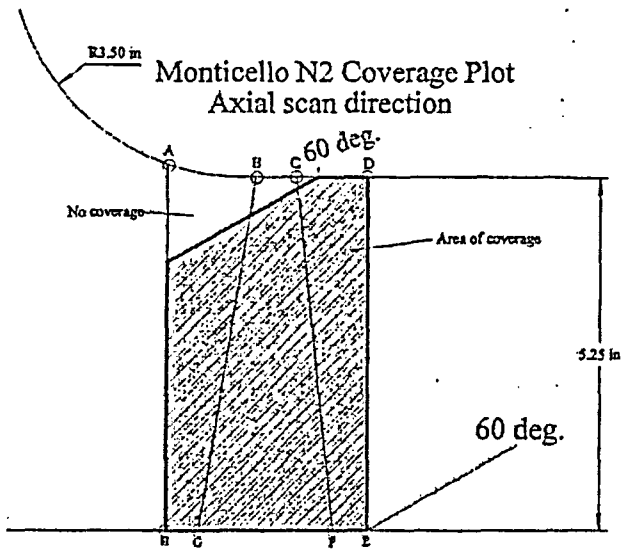



Supplemental Report

Report No.: 2005UT005

Summary No.: 102672

Comments: Limitation due to radius area, no contact.

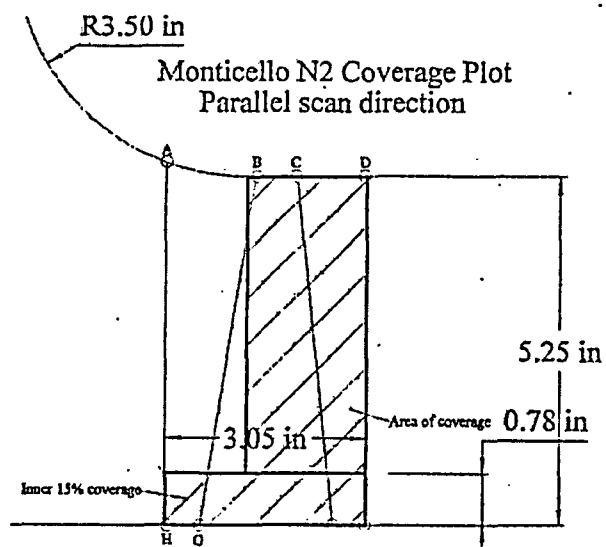

Component – N-2J NV Report # 2005UT005



Supplemental Report

Report No.: 2005UT005

Summary No.: 102672

Comments: Limitation due to transducer size and radius area, no contact.

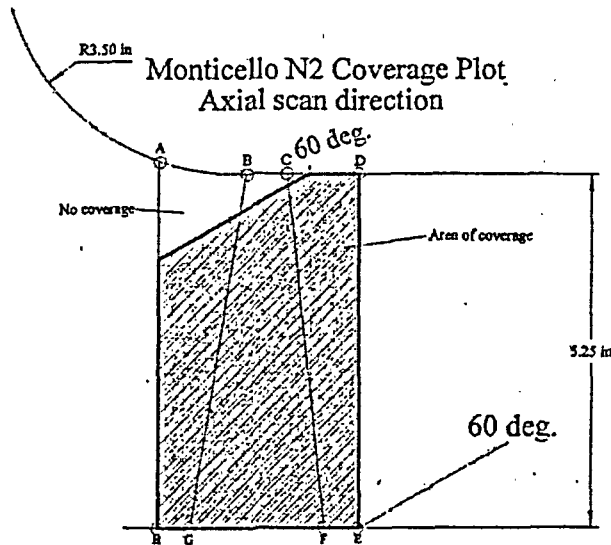

Component – N-3A NV Report # 2005UT023



Supplemental Report

Report No.: 2005UT023

Summary No.: 102676

Comments: Monticello N3 Coverage Plot  
 \* Axial scan limitation due to transducer size and radius area, no contact.  
 \* Parallel scan limitation due to radius area, no contact.

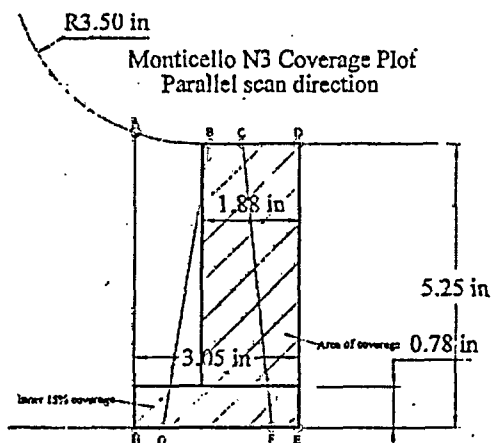
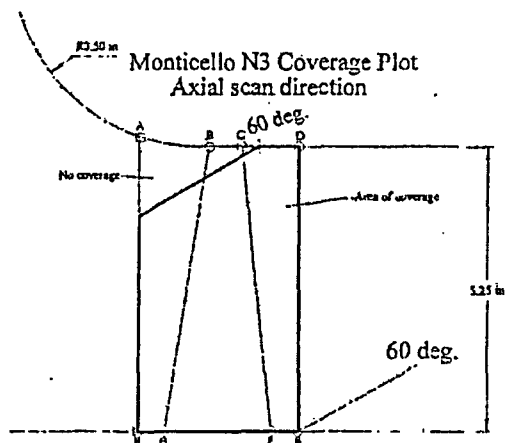



Supplemental Report

Report No.: 2005UT025

Summary No.: 102688

Comments: Limitation due to radius area, no contact.

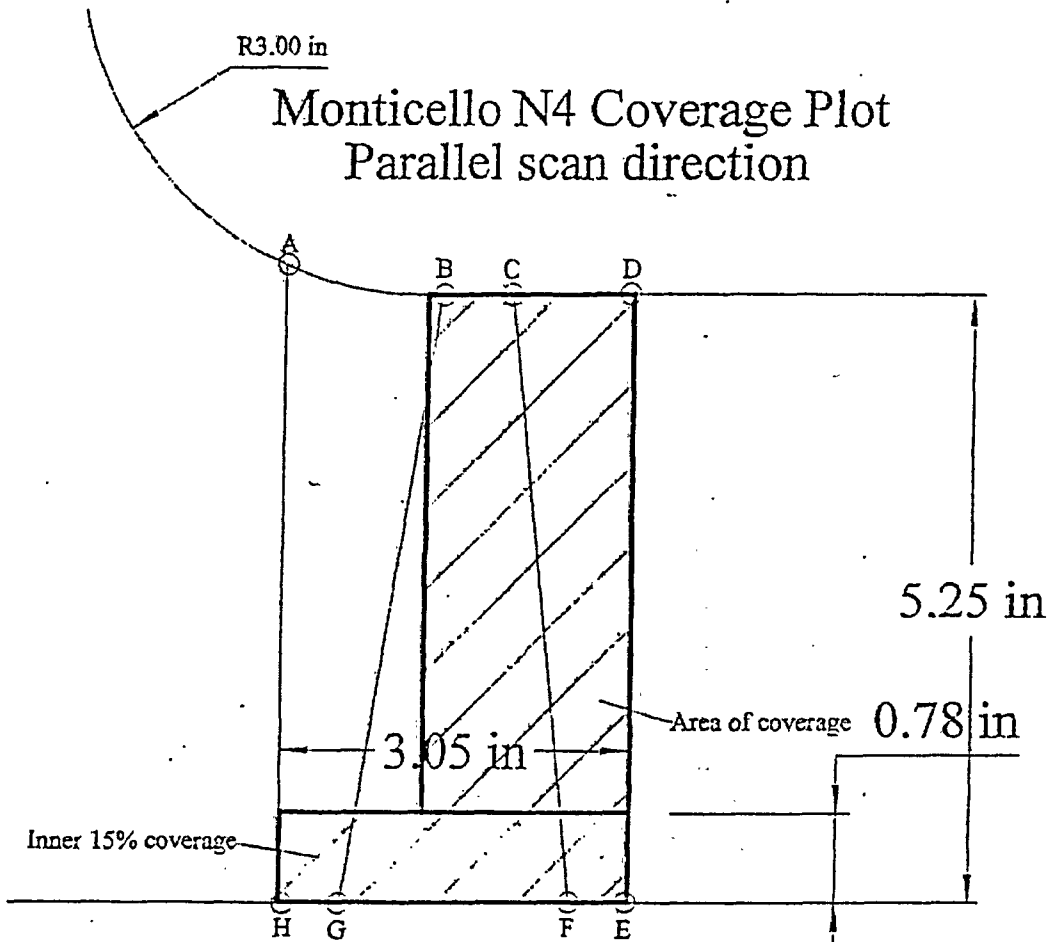



Supplemental Report

Report No.: 2005UT025

Summary No.: 102688

Comments: Limitation due to transducer size and radius area, no contact.

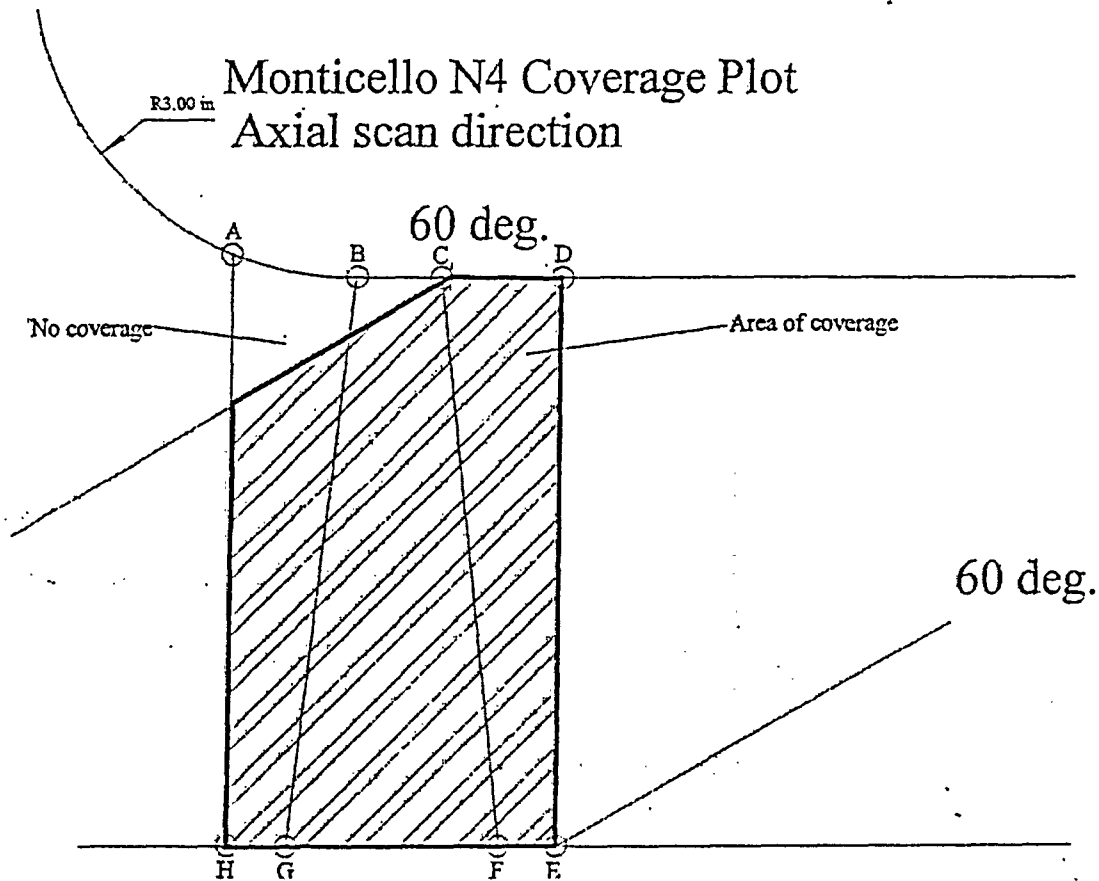

Component – N-5B NV Report # 2005UT018



Supplemental Report

Report No.: 2005UT018

Summary No.: 102694

Comments: Monticello N5B Coverage Plot  
\* Axial scan limitation due to transducer size and radius area, no contact.  
\* Parallel scan limitation due to radius area, no contact.

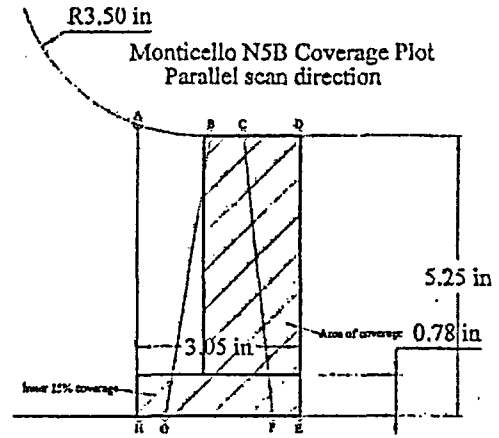
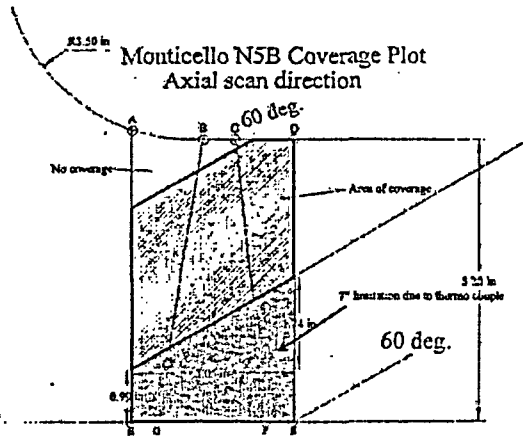



Supplemental Report

Report No.: 2005UT018

Summary No.: 102694

---

Comments: 7" Limitation due to thermo-couple top dead center of nozzle.

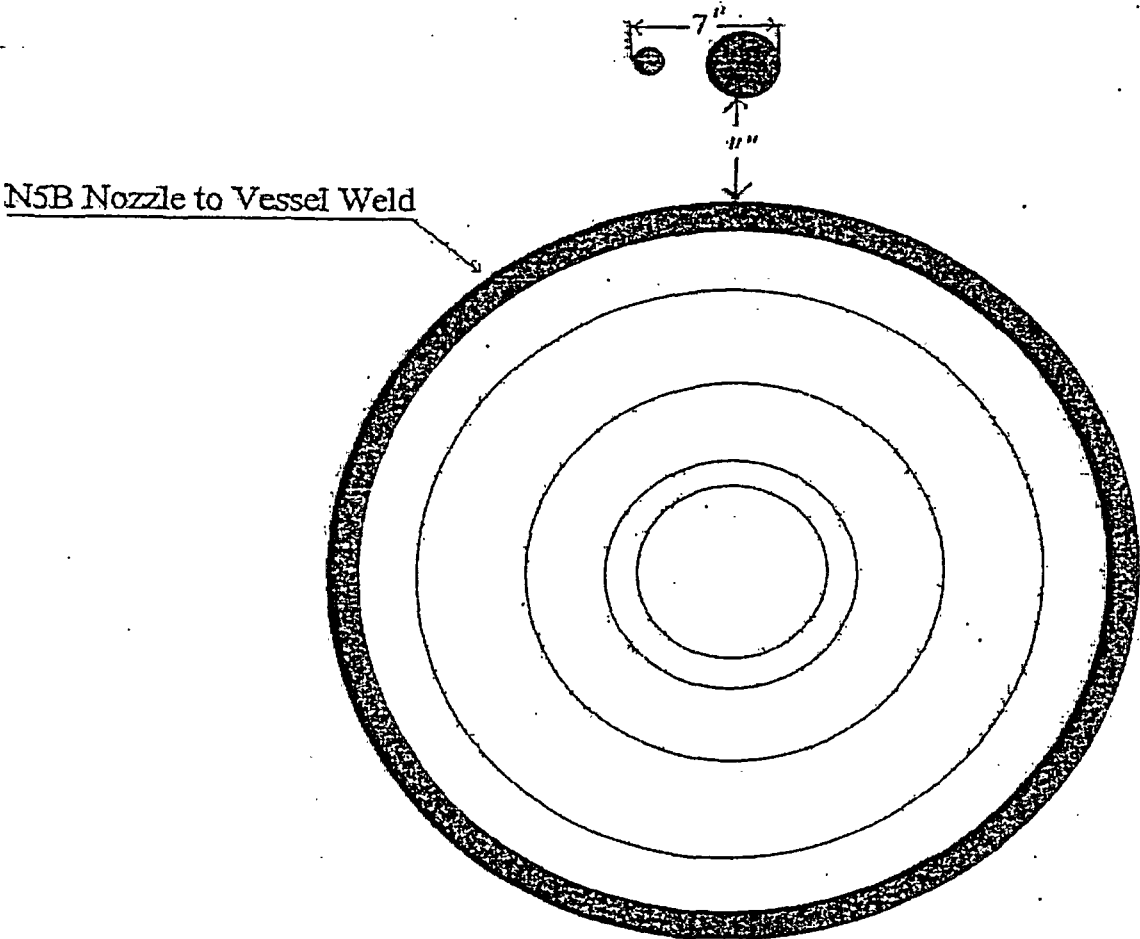



Component – N-8A NV Report # 2005UT037



Supplemental Report

Report No.: 2005UT037

Summary No.: 102696

Comments: Monticello N8 Coverage Plots.  
\* Axial scan limitation due to transducer size and radius area, no contact.  
\* Parallel scan limitation due to radius area, no contact.

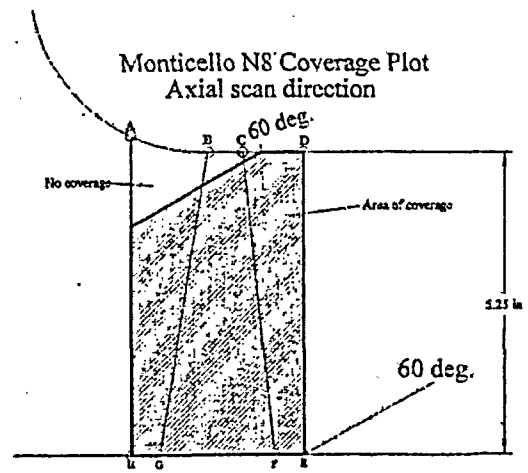
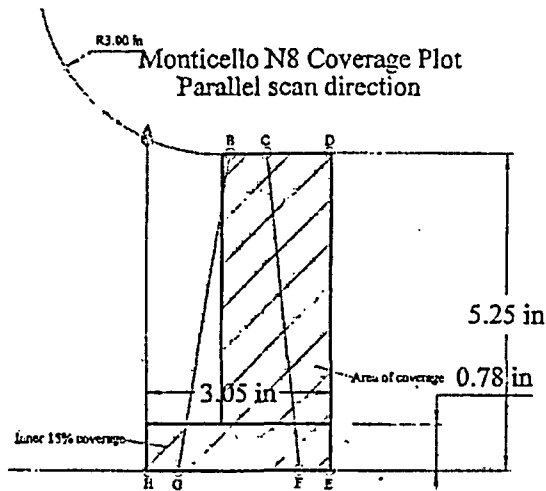

Typical for Nozzle Limitations

Coverage affected by liftoff  
due to radius

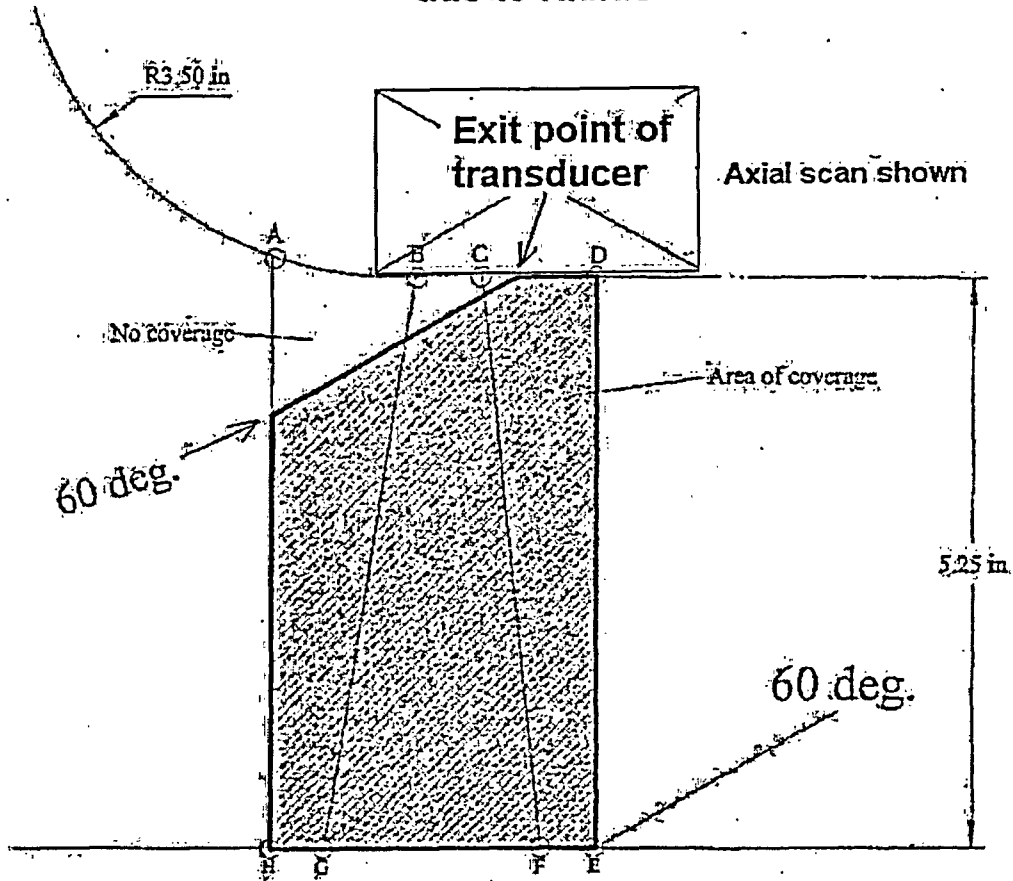

N2 Nozzle shown as example