

**UNITED STATES NUCLEAR REGULATORY COMMISSION
PRESSURIZED WATER REACTOR GENERIC FUNDAMENTALS EXAMINATION
SEPTEMBER 2005--FORM A**

Please Print

Name: _____

Facility: _____

Docket No.: _____

Start Time: _____ Stop Time: _____

INSTRUCTIONS TO APPLICANT

Answer all the test items using the answer sheet provided, ensuring a single answer is marked for each test item. Each test item has equal point value. A score of at least 80% is required to pass this portion of the NRC operator licensing written examination. All examination papers will be collected 3.0 hours after the examination starts. This examination applies to a typical pressurized water reactor (PWR) nuclear power plant.

SECTION	QUESTIONS	% OF TOTAL	SCORE
COMPONENTS	1 - 22		
REACTOR THEORY	23 - 36		
THERMODYNAMICS	37 - 50		
TOTALS	50		

All work performed on this examination is my own. I have neither given nor received aid.

))))))))))))))))))))))))))))))))))
Applicant's Signature

**RULES AND GUIDELINES FOR THE NRC
GENERIC FUNDAMENTALS EXAMINATION**

During the administration of this examination the following rules apply:

NOTE: The generic term "control rod" refers to the length of neutron absorber material that can be positioned by the operator to change core reactivity.

1. Print your name in the blank provided on the cover sheet of the examination.
2. Fill in the name of your facility.
3. Fill in your individual docket number.
4. Fill in your start and stop times at the appropriate time.
5. Two aids are provided for your use during the examination:
 - (1) An equations and conversions sheet contained within the examination copy, and
 - (2) Steam tables and Mollier Diagram provided by your proctor.
6. Place your answers on the answer sheet provided. Credit will only be given for answers properly marked on this sheet. Follow the instructions for filling out the answer sheet.
7. Scrap paper will be provided for calculations.
8. Cheating on the examination will result in the automatic forfeiture of this examination. Cheating could also result in severe penalties.
9. Restroom trips are limited. Only **ONE** examinee may leave the room at a time. In order to avoid the appearance or possibility of cheating, avoid all contact with anyone outside of the examination room.
10. After you have completed the examination, sign the statement on the cover sheet indicating that the work is your own and you have neither given nor received any assistance in completing the examination.
11. Turn in your examination materials, answer sheet on top, followed by the examination booklet, then examination aids - steam table booklets, handouts, and scrap paper used during the examination.
12. After turning in your examination materials, leave the examination area, as defined by the proctor. If after leaving you are found in the examination area while the examination is in progress, your examination may be forfeited.

GENERIC FUNDAMENTALS EXAMINATION
EQUATIONS AND CONVERSIONS HANDOUT SHEET

EQUATIONS

$$Q = \rho_p \Delta T$$

$$Q = \rho \Delta h$$

$$Q = UA\Delta T$$

$$Q \% \rho_{\text{Nat}}^3 \text{ Circ}$$

$$\Delta T \% \rho_{\text{Nat}}^2 \text{ Circ}$$

$$K_{\text{eff}} = 1/(1 - \rho)$$

$$\rho = (K_{\text{eff}} - 1)/K_{\text{eff}}$$

$$\text{SUR} = 26.06/\tau$$

$$\tau = \frac{\bar{\beta} \& \rho}{\lambda_{\text{eff}} \rho}$$

$$\rho = \frac{\bar{R}}{\tau} \% \frac{\bar{\beta}}{1 \% \lambda_{\text{eff}} \tau}$$

$$\bar{R} = 1 \times 10^{-4} \text{ sec}$$

$$\lambda_{\text{eff}} = 0.1 \text{ sec}^{-1} \text{ (for small positive } \rho)$$

$$\text{DRW} \% \phi_{\text{tip}}^2 / \phi_{\text{avg}}^2$$

$$P = P_0 10^{\text{SUR}(t)}$$

$$P = P_0 e^{(t/\tau)}$$

$$A = A_0 e^{-\lambda t}$$

$$\text{CR}_{\text{S/D}} = S/(1 - K_{\text{eff}})$$

$$\text{CR}_1(1 - K_{\text{eff}1}) = \text{CR}_2(1 - K_{\text{eff}2})$$

$$1/M = \text{CR}_1/\text{CR}_x$$

$$A = \pi r^2$$

$$F = PA$$

$$\rho = \rho A v$$

$$W_{\text{Pump}} = \rho \Delta P v$$

$$E = IR$$

$$P = IE$$

$$\text{Eff.} = \text{Net Work Out/Energy In}$$

$$\frac{g(z_2 - z_1)}{g_c} + \frac{(v_2^2 - v_1^2)}{2g_c} + v(P_2 - P_1) + (u_2 - u_1) + (q - w) = 0$$

$$g_c = 32.2 \text{ lbf-ft/lbf-sec}^2$$

CONVERSIONS

$$1 \text{ Mw} = 3.41 \times 10^6 \text{ Btu/hr}$$

$$1 \text{ hp} = 2.54 \times 10^3 \text{ Btu/hr}$$

$$1 \text{ Btu} = 778 \text{ ft-lbf}$$

$$\text{EC} = (5/9)(\text{EF} - 32)$$

$$\text{EF} = (9/5)(\text{EC}) + 32$$

$$1 \text{ Curie} = 3.7 \times 10^{10} \text{ dps}$$

$$1 \text{ kg} = 2.21 \text{ lbf}$$

$$1 \text{ gal}_{\text{water}} = 8.35 \text{ lbf}$$

$$1 \text{ ft}^3_{\text{water}} = 7.48 \text{ gal}$$

**USNRC GENERIC FUNDAMENTALS EXAMINATION
SEPTEMBER 2005 PWR--FORM A**

QUESTION: 1

A typical motor-operated valve (MOV) has just been opened from the main control room, and the breaker for the MOV has been opened. A plant operator has been directed to close the MOV locally for a surveillance test.

If the operator attempts to turn the MOV handwheel in the clockwise direction without first operating the clutch lever, which one of the following will occur?

- A. The handwheel will turn, but the valve stem will not move.
- B. The handwheel will not turn, and the valve stem will not move.
- C. The handwheel will turn, and the valve stem will move toward the closed position because the clutch is automatically engaged when the handwheel is turned.
- D. The handwheel will turn, and the valve stem will move toward the closed position because the clutch is automatically engaged when the breaker is opened.

QUESTION: 2

A typical check valve is designed to...

- A. permit flow in only one direction.
- B. prevent system overpressure.
- C. isolate system components.
- D. perform automatic pump venting.

**USNRC GENERIC FUNDAMENTALS EXAMINATION
SEPTEMBER 2005 PWR--FORM A**

QUESTION: 3

A differential pressure detector is being used with an orifice plate to measure water flow rate through a pipe. When the flow detector was last calibrated, the following parameters were observed:

Upstream Pressure: 125 psig Actual Flow Rate: 100 gpm
Downstream Pressure: 116 psig Indicated Flow Rate: 100 gpm

Significant erosion of the orifice has occurred since the calibration such that actual flow rate through the orifice has increased to 120 gpm while the upstream and downstream pressures have changed to 110 psig and 106 psig respectively.

What is the approximate flow rate that is currently indicated?

- A. 44 gpm
- B. 67 gpm
- C. 81 gpm
- D. 120 gpm

**USNRC GENERIC FUNDAMENTALS EXAMINATION
SEPTEMBER 2005 PWR--FORM A**

QUESTION: 4

Refer to the drawing of a pressurizer differential pressure (D/P) level detector (see figure below).

A nuclear power plant uses several differential pressure detectors like the one below to provide multiple channels of pressurizer water level indication. A hot channel was calibrated when the pressurizer was at normal operating temperature. A cold channel was calibrated when the pressurizer was at 160°F.

How do the two pressurizer level indication channels compare when the pressurizer is at normal operating temperature?

- A. The cold channel will indicate higher than the hot channel due to the difference in water density in the pressurizer at the two calibration temperatures.
- B. The cold channel will indicate lower than the hot channel due to the difference in water density in the pressurizer at the two calibration temperatures.
- C. The cold channel will indicate higher than the hot channel due to the difference in water density in the reference legs at the two calibration temperatures.
- D. The cold channel will indicate lower than the hot channel due to the difference in water density in the reference legs at the two calibration temperatures.

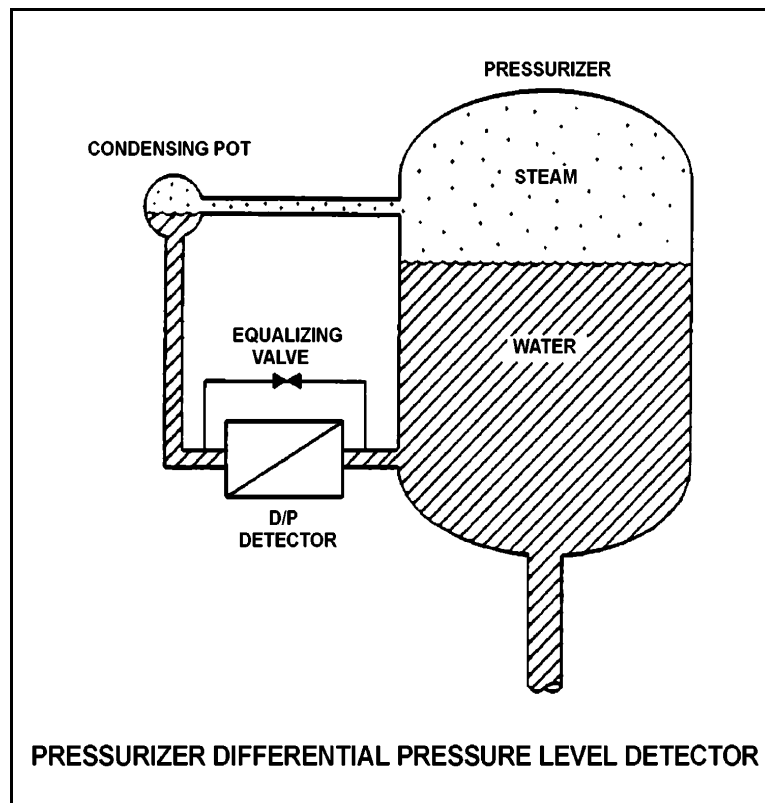

**USNRC GENERIC FUNDAMENTALS EXAMINATION
SEPTEMBER 2005 PWR--FORM A**

QUESTION: 5

A nuclear power plant startup is in progress immediately following a reactor refueling outage. The external nuclear instrumentation (NI) was calibrated at 90% power just prior to the refueling outage and has not been readjusted.

If actual reactor power level is increased to 90% and stabilized, NI power level will be _____ than actual reactor power level because, when compared to pre-outage 90% power level operation, _____.

- A. higher; the total core fission rate has increased
- B. lower; the total core fission rate has decreased
- C. higher; the fission rate in the outer portion of the core has increased
- D. lower; the fission rate in the outer portion of the core has decreased

QUESTION: 6

A nuclear power plant has been shutdown for one month. A portable gas-filled radiation detector is needed to monitor shutdown reactor core neutron level from a location outside the reactor vessel. The detector must be able to distinguish between ionizations caused by gamma and neutron radiation.

Which region(s) of the gas-filled detector characteristic curve is/are acceptable for operation of the detector?

- A. Geiger-Mueller, Ionization, and Proportional regions are all acceptable.
- B. Proportional region is acceptable, and Ionization region also may be usable.
- C. Ionization region is acceptable, and Geiger-Mueller region also may be usable.
- D. Geiger-Mueller region is acceptable, and Proportional region also may be usable.

**USNRC GENERIC FUNDAMENTALS EXAMINATION
SEPTEMBER 2005 PWR--FORM A**

QUESTION: 7

If the turbine shaft speed signal received by a typical turbine governor control system fails high during turbine startup, the turbine governor will cause turbine speed to...

- A. increase, until an upper limit is reached or the turbine trips on overspeed.
- B. decrease, until the mismatch with the turbine speed demand signal is nulled.
- C. increase, until the mismatch with the turbine speed demand signal is nulled.
- D. decrease, until a lower limit is reached or turbine steam flow is isolated.

**USNRC GENERIC FUNDAMENTALS EXAMINATION
SEPTEMBER 2005 PWR--FORM A**

QUESTION: 8

Refer to the drawing of four bistable symbols (see figure below).

A temperature controller uses a bistable that turns on to actuate a warning light when the controlled temperature reaches a high setpoint. The bistable turns off to extinguish the warning light when the temperature decreases to 5°F below the high setpoint.

Which one of the following bistable symbols indicates the characteristics of the bistable?

- A. 1.
- B. 2.
- C. 3.
- D. 4.

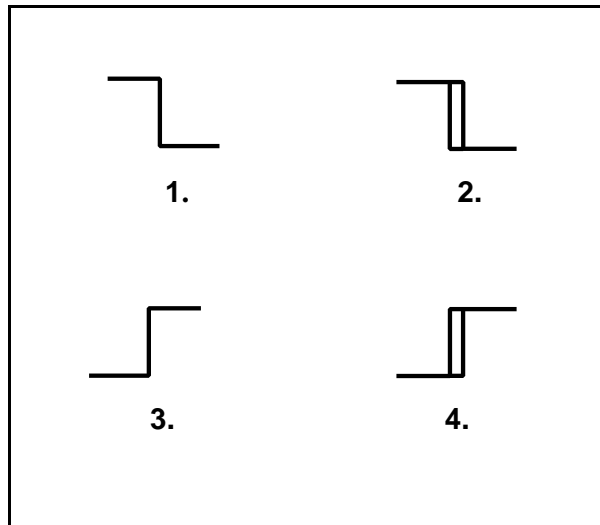

**USNRC GENERIC FUNDAMENTALS EXAMINATION
SEPTEMBER 2005 PWR--FORM A**

QUESTION: 9

Refer to the drawing of a water storage tank with a level control system (see figure below). The tank water level is being automatically controlled at 50% by a proportional-integral (PI) controller that positions the drain valve. Tank water level is currently stable with 500 gpm entering the tank and the drain valve 50% open.

Tank inlet flow rate suddenly increases to 700 gpm and remains constant. When tank water level stabilizes, level will be _____, and the drain valve position will be _____.

- A. higher than 50%; more open
- B. higher than 50%; the same
- C. 50%; more open
- D. 50%; the same

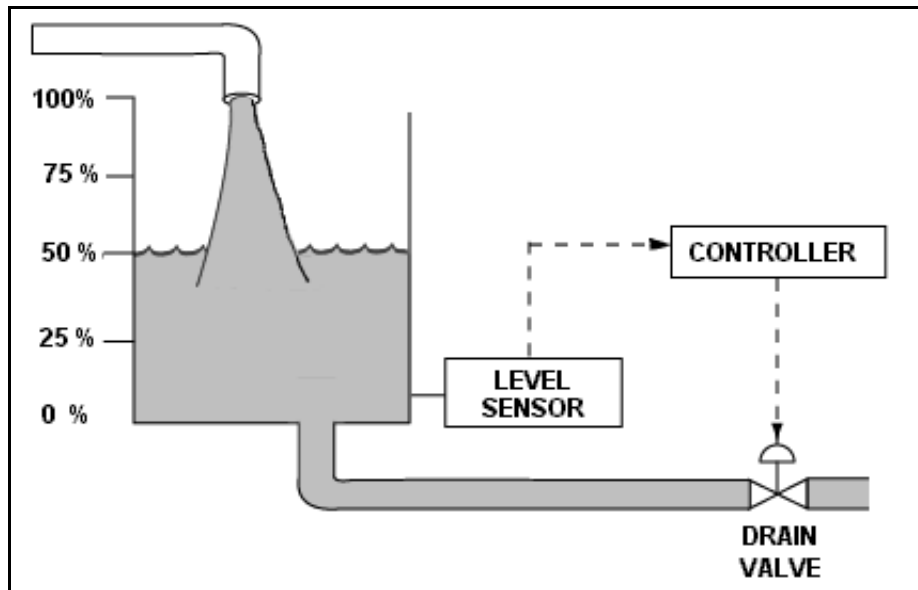

**USNRC GENERIC FUNDAMENTALS EXAMINATION
SEPTEMBER 2005 PWR--FORM A**

QUESTION: 10

Which one of the following is an effective method for ensuring that a centrifugal pump remains primed and does not become gas bound during operation and after shutdown?

- A. Install an orifice plate in the discharge piping of the pump.
- B. Install a pump recirculation line from the pump discharge piping to the pump supply piping.
- C. Install the pump below the level of the suction supply.
- D. Install a check valve in the discharge piping of the pump.

QUESTION: 11

A constant-speed centrifugal pump motor draws the most current when the pump is...

- A. operating at runout flow.
- B. at maximum rated flow conditions.
- C. at shutoff head with no recirculation flow.
- D. accelerating to normal speed during start.

**USNRC GENERIC FUNDAMENTALS EXAMINATION
SEPTEMBER 2005 PWR--FORM A**

QUESTION: 12

A centrifugal firewater pump is operating to pressurize a fire main. The pump takes suction from a water reservoir. A fire hose connected to the fire main is being used to suppress an elevated fire.

Given:

- The pump eye is located 5 feet above the reservoir water level.
- The pump has a design shutoff head of 120 feet.
- The required net positive suction head (NPSH) for the pump is 15 feet.
- The reservoir water temperature is 60°F.

At which one of the following elevations above the pump eye will the fire hose spray nozzle first be unable to provide flow? (Disregard all sources of system frictional head loss.)

- A. 111 feet
- B. 116 feet
- C. 121 feet
- D. 126 feet

**USNRC GENERIC FUNDAMENTALS EXAMINATION
SEPTEMBER 2005 PWR--FORM A**

QUESTION: 13

A section of reactor coolant piping is being hydrostatically tested to 2,900 psig using a positive displacement pump. The operating characteristics of the positive displacement pump are shown below identifying ideal, design, and actual pump performance during the test.

Which one of the following could have caused the observed difference between the design and the actual pump performance?

- A. Available NPSH decreased to slightly above the required NPSH for the pump.
- B. Available NPSH decreased to slightly below the required NPSH for the pump.
- C. A relief valve on the pump discharge piping failed to open at its set point of 2,900 psig.
- D. A relief valve on the pump discharge piping opened prior to its set point of 2,900 psig.

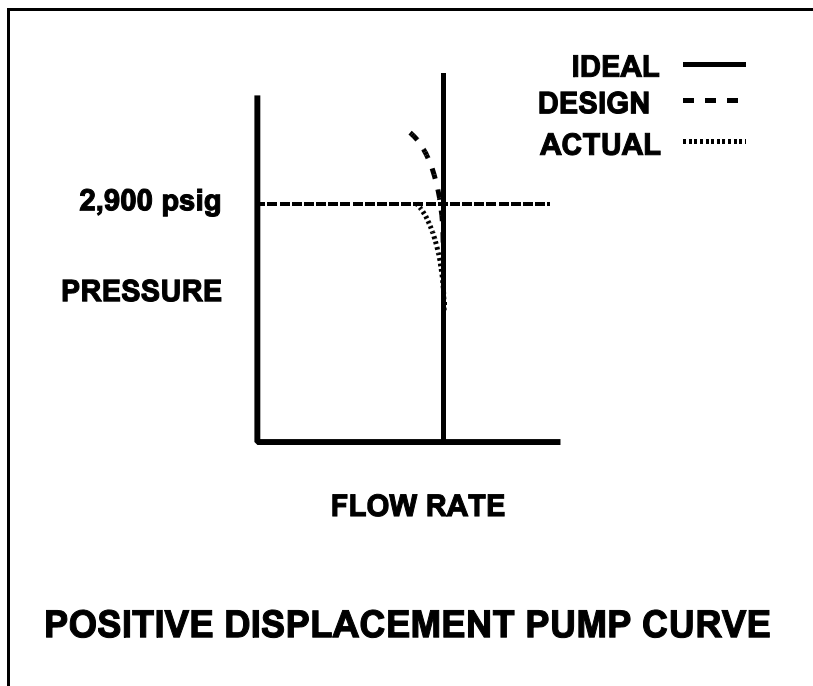

**USNRC GENERIC FUNDAMENTALS EXAMINATION
SEPTEMBER 2005 PWR--FORM A**

QUESTION: 14

Which one of the following breaker trip signals will trip the associated motor breaker if a motor bearing seizes while the motor is running?

- A. Undervoltage
- B. Underfrequency
- C. Time-delayed overcurrent
- D. Instantaneous overcurrent

**USNRC GENERIC FUNDAMENTALS EXAMINATION
SEPTEMBER 2005 PWR--FORM A**

QUESTION: 15

Refer to the pump performance curves for a centrifugal cooling water pump (see figure below). The pump is being driven by a single-speed ac induction motor. Pump flow rate is being controlled by a throttled discharge flow control valve.

The following initial pump conditions exist:

Pump motor current: 50 amps
Pump flow rate: 400 gpm
Pump suction temperature: 70°F

If the flow control valve is repositioned such that pump flow rate is now 800 gpm, what will be the approximate new pump motor current?

- A. Less than 100 amps
- B. 200 amps
- C. 400 amps
- D. More than 500 amps

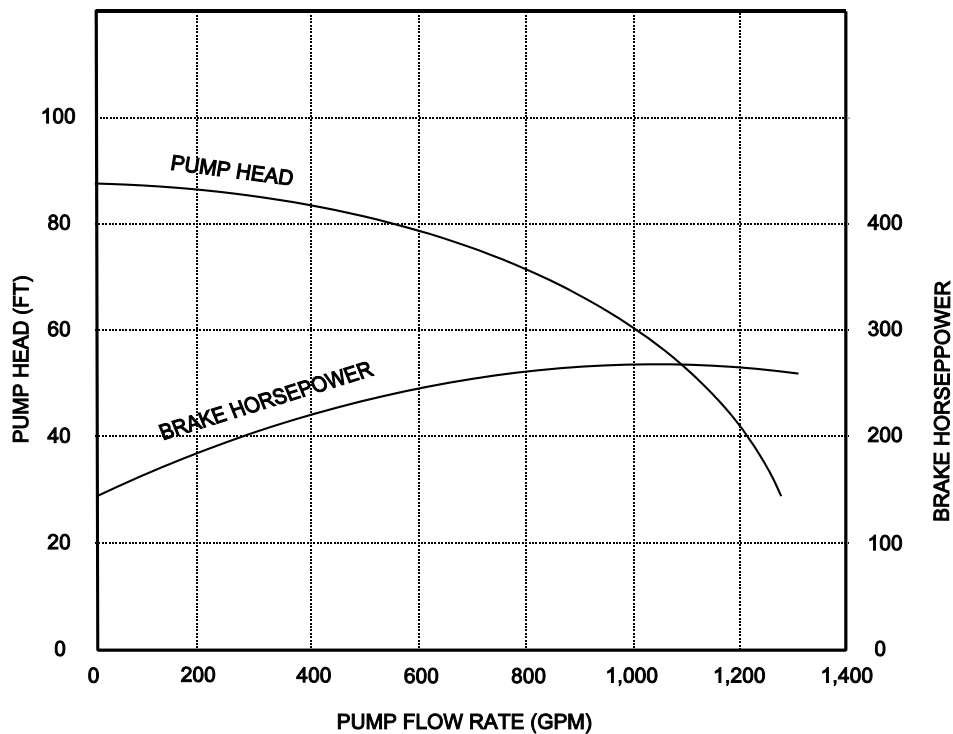

USNRC GENERIC FUNDAMENTALS EXAMINATION
SEPTEMBER 2005 PWR--FORM A

QUESTION: 16

Refer to the drawing of an operating water cleanup system (see figure below).

All valves are identical and are initially 50% open. To lower the temperature at point 4, the operator can adjust valve _____ in the _____ direction.

- A. D; shut
- B. C; open
- C. B; shut
- D. A; open

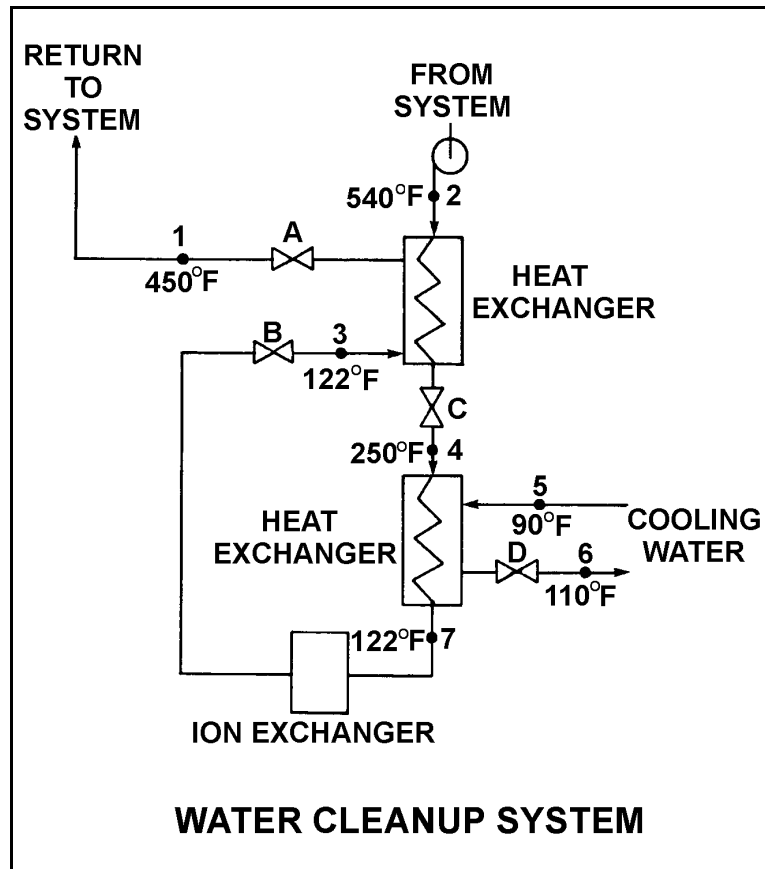

**USNRC GENERIC FUNDAMENTALS EXAMINATION
SEPTEMBER 2005 PWR--FORM A**

QUESTION: 17

Refer to the drawing of an operating lube oil heat exchanger (see figure below).

Given the following initial parameters:

Cooling water inlet temperature (T_{cw-in}) = 75EF
Cooling water outlet temperature (T_{cw-out}) = 105EF
Oil inlet temperature (T_{oil-in}) = 140EF
Oil outlet temperature ($T_{oil-out}$) = 100EF

Air introduction to the heat exchanger results in some of the heat exchanger tubes becoming uncovered. As a result, T_{cw-out} decreases to 99EF. Assume that the mass flow rate and specific heat of both fluids remain the same, and that T_{oil-in} does not change. Which one of the following will be the approximate temperature of the oil exiting the heat exchanger ($T_{oil-out}$)?

- A. 99EF
- B. 108EF
- C. 116EF
- D. 122EF

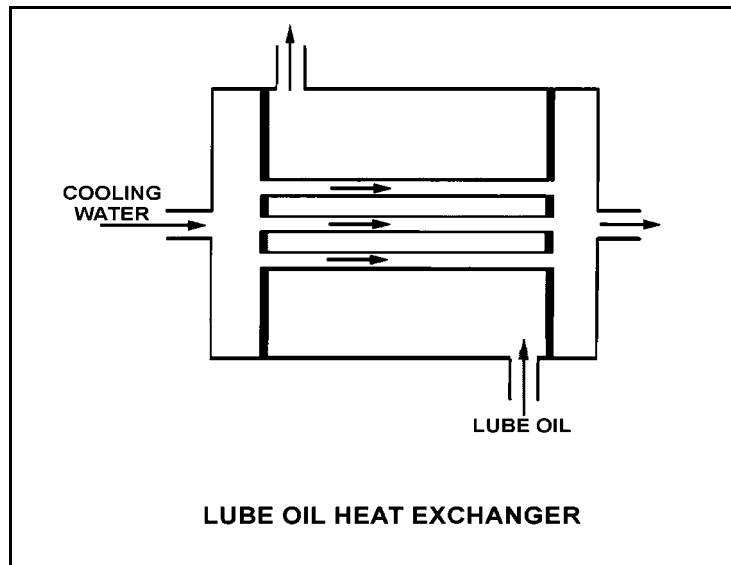

**USNRC GENERIC FUNDAMENTALS EXAMINATION
SEPTEMBER 2005 PWR--FORM A**

QUESTION: 18

As the operating time of a demineralizer resin bed increases, the differential pressure across the bed...

- A. increases due to depletion of resin sites.
- B. increases due to trapping of suspended solids.
- C. decreases due to gradual resin breakdown.
- D. decreases due to erosion of the resin sites.

**USNRC GENERIC FUNDAMENTALS EXAMINATION
SEPTEMBER 2005 PWR--FORM A**

QUESTION: 19

Refer to the drawing of a parallel demineralizer loop that is currently aligned for normal flow direction through the demineralizer (see figure below).

A minor seawater leak has occurred into the process water system, which is a closed system. Which one of the following will decrease the time required for the demineralizer loop to reduce the concentration of ionic impurities in the process water system?

- A. Reverse the flow direction through the demineralizer.
- B. Divert 50% of the loop flow to bypass the demineralizer.
- C. Increase the flow rate in the loop from 95 gpm to 105 gpm.
- D. Decrease the temperature in the loop from 110EF to 100EF.

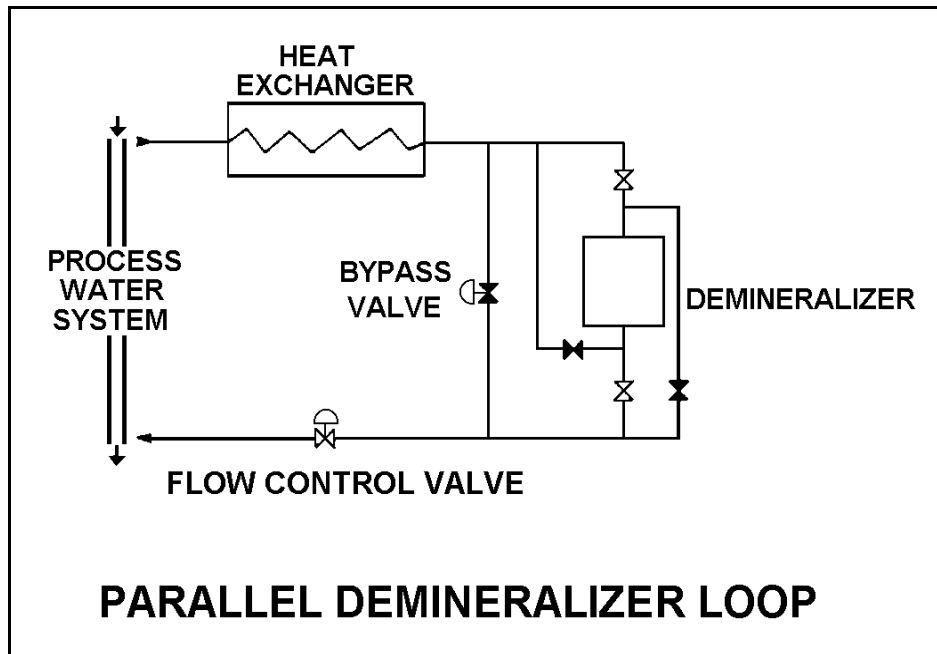

**USNRC GENERIC FUNDAMENTALS EXAMINATION
SEPTEMBER 2005 PWR--FORM A**

QUESTION: 20

Two identical 1,000 MW electrical generators are operating in parallel supplying the same isolated electrical bus. The generator output breakers also provide identical protection for the generators. Generator A and B output indications are as follows:

<u>Generator A</u>	<u>Generator B</u>
22 KV	22 KV
60.2 Hertz	60.2 Hertz
200 MW	200 MW
25 MVAR (out)	50 MVAR (out)

A malfunction causes the voltage regulator setpoint for generator A to slowly increase continuously toward a maximum of 25 KV. If no operator action is taken, generator B output current will...

- A. initially decrease, and then increase until the output breaker for generator A trips on overcurrent.
- B. initially decrease, and then increase until the output breaker for generator B trips on overcurrent.
- C. increase continuously until the output breaker for generator A trips on overcurrent.
- D. increase continuously until the output breaker for generator B trips on overcurrent.

**USNRC GENERIC FUNDAMENTALS EXAMINATION
SEPTEMBER 2005 PWR--FORM A**

QUESTION: 21

Refer to the drawing of a valve motor control circuit (see figure below) for a valve that is currently fully closed and has a 10-second stroke time. (Note: Limit switch (LS) contacts are shown open regardless of valve position, but relay contacts follow the standard convention for control circuit drawings.)

Which one of the following describes the valve response if the control switch is taken to the “Open” position for two seconds and then released?

- A. The valve will not move.
- B. The valve will open fully.
- C. The valve will begin to open and then close fully.
- D. The valve will begin to open and then stop moving.

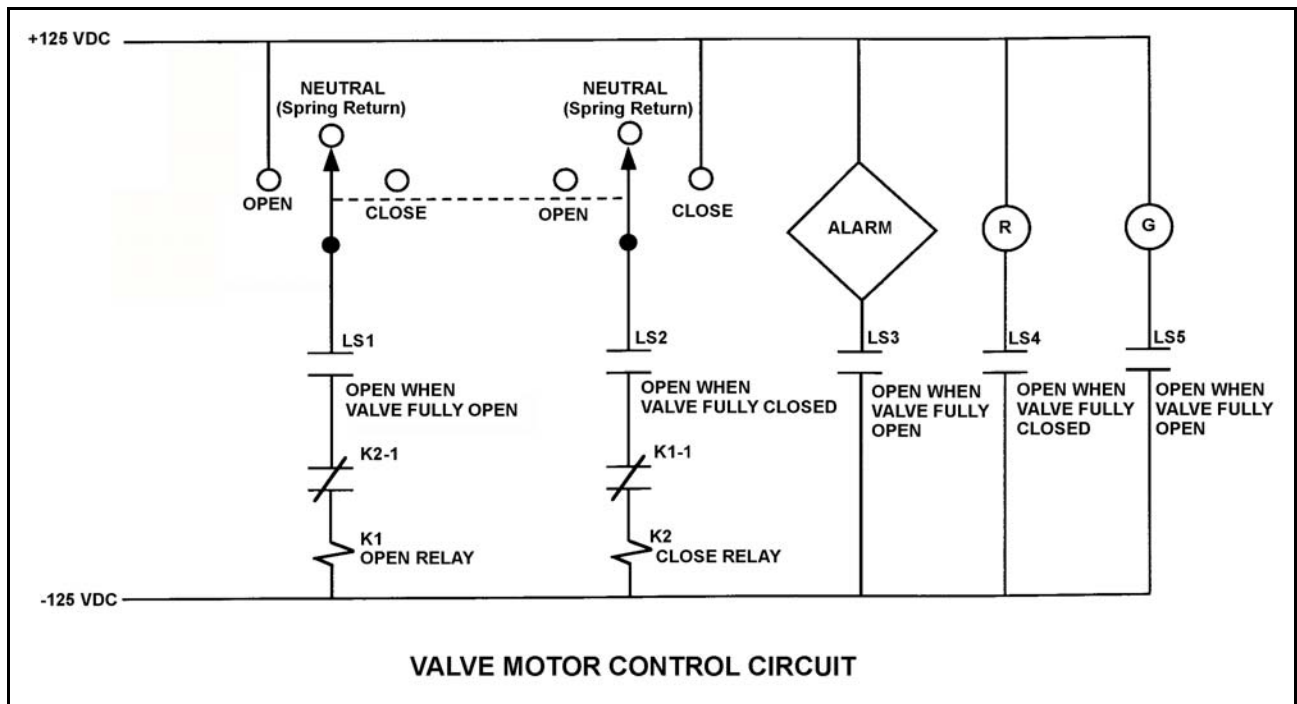

**USNRC GENERIC FUNDAMENTALS EXAMINATION
SEPTEMBER 2005 PWR--FORM A**

QUESTION: 22

A main generator is about to be connected to an infinite power grid. Generator voltage is slightly higher than grid voltage and the synchroscope is rotating slowly in the clockwise direction. The generator breaker is closed just as the synchroscope pointer reaches the 12 o'clock position.

Which one of the following will occur after the breaker is closed?

- A. The breaker will remain closed and the generator will supply only MW to the grid.
- B. The breaker will remain closed and the generator will supply both MW and MVAR to the grid.
- C. The breaker will open due to overcurrent.
- D. The breaker will open due to reverse power.

QUESTION: 23

A neutron that is born 1.0×10^{-2} seconds after the associated fission event is a _____ neutron.

- A. thermal
- B. delayed
- C. prompt
- D. capture

**USNRC GENERIC FUNDAMENTALS EXAMINATION
SEPTEMBER 2005 PWR--FORM A**

QUESTION: 24

A nuclear power plant is operating at 100% power with rod control in Manual. If no operator action is taken, then during the next two weeks of steady-state operation at 100% power shutdown margin will...

- A. continuously decrease
- B. initially decrease, then return to the same value due to changing coolant temperature.
- C. continuously increase
- D. initially increase, then return to the same value due to changing coolant temperature.

QUESTION: 25

A nuclear power plant is being cooled down from 500°F to 190°F. Just prior to commencing the cooldown, the readings for all source range nuclear instruments were stable at 32 counts per second (cps). After two hours, with reactor coolant temperature at 350°F, the source range count rate is stable at 64 cps.

Assume that the moderator temperature coefficient remains constant throughout the cooldown, reactor power remains below the point of adding heat, and no reactor protection actions occur.

Without additional operator action, what will be the status of the reactor when reactor coolant temperature reaches 190°F?

- A. Subcritical, with source range count rate below 150 cps
- B. Subcritical, with source range count rate above 150 cps
- C. Exactly critical
- D. Supercritical

**USNRC GENERIC FUNDAMENTALS EXAMINATION
SEPTEMBER 2005 PWR--FORM A**

QUESTION: 26

As core age increases, for the same power level the fuel temperature coefficient of reactivity becomes _____ negative because average fuel temperature _____.

- A. more; decreases
- B. more; increases
- C. less; decreases
- D. less; increases

QUESTION: 27

As moderator temperature increases, differential boron reactivity worth will become _____ negative because, at higher moderator temperatures, a 1 ppm increase in reactor coolant system boron concentration will add _____ boron atoms to the core.

- A. more; fewer
- B. more; more
- C. less; fewer
- D. less; more

**USNRC GENERIC FUNDAMENTALS EXAMINATION
SEPTEMBER 2005 PWR--FORM A**

QUESTION: 28

Reactor power was ramped from 80% power to 100% power over 4 hours. The 80% conditions were as follows:

Reactor coolant system (RCS) boron concentration:	600 ppm
Control rod position:	110 inches
RCS average temperature:	575 °F

The 100% conditions are as follows:

RCS boron concentration:	580 ppm
Control rod position:	130 inches
RCS average temperature:	580 °F

Given the following reactivity coefficient/worth values, and neglecting changes in fission product poison reactivity, what is the differential control rod worth?

Power coefficient:	-0.03% $\Delta K/K/\%$
Moderator temperature coefficient:	-0.02% $\Delta K/K/^\circ F$
Differential boron worth:	-0.01% $\Delta K/K/ppm$

- A. -0.02% $\Delta K/K/inch$
- B. -0.025% $\Delta K/K/inch$
- C. -0.04% $\Delta K/K/inch$
- D. -0.05% $\Delta K/K/inch$

**USNRC GENERIC FUNDAMENTALS EXAMINATION
SEPTEMBER 2005 PWR--FORM A**

QUESTION: 29

A nuclear power plant is operating at 80% power with manual rod control. It has been determined that power distribution is excessive in the lower half of the core.

Which one of the following will shift power distribution toward the upper half of the core? (Assume no additional operator actions.)

- A. Increasing power to 90%.
- B. Withdrawing control rods.
- C. Borating the reactor coolant system.
- D. Diluting the reactor coolant system.

QUESTION: 30

A nuclear reactor has been operating at full power for several weeks. Xenon-135 is being directly produced as a fission product in approximately _____% of all fissions.

- A. 0.3
- B. 3.0
- C. 30
- D. 100

**USNRC GENERIC FUNDAMENTALS EXAMINATION
SEPTEMBER 2005 PWR--FORM A**

QUESTION: 31

A nuclear reactor is initially operating at 80% power with equilibrium core xenon-135. Power is increased to 100% over a 2-hour period and average reactor coolant temperature is adjusted to 585°F using manual rod control. Rod control is left in Manual and no subsequent operator actions are taken.

Considering only the reactivity effects of core xenon-135 changes, which one of the following describes the average reactor coolant temperature 24 hours after the power change is completed?

- A. Greater than 585°F and decreasing slowly
- B. Greater than 585°F and increasing slowly
- C. Less than 585°F and decreasing slowly
- D. Less than 585°F and increasing slowly

QUESTION: 32

Which one of the following is not a function performed by burnable poisons in an operating nuclear reactor?

- A. Provide neutron flux shaping.
- B. Provide more uniform power density.
- C. Counteract the effects of control rod burnout.
- D. Allow higher fuel enrichment of initial core load.

**USNRC GENERIC FUNDAMENTALS EXAMINATION
SEPTEMBER 2005 PWR--FORM A**

QUESTION: 33

A nuclear power plant was operating at steady-state 100% power near the end of a fuel cycle when a reactor trip occurred. Four hours after the trip, with reactor coolant temperature at normal no-load temperature, which one of the following will cause the fission rate in the reactor core to increase?

- A. The operator fully withdraws the shutdown control rods.
- B. Reactor coolant temperature is allowed to increase by 3°F.
- C. Reactor coolant boron concentration is increased by 10 ppm.
- D. An additional two hours is allowed to pass with no other changes in plant parameters.

**USNRC GENERIC FUNDAMENTALS EXAMINATION
SEPTEMBER 2005 PWR--FORM A**

QUESTION: 34

A nuclear reactor is critical in the source range during a reactor startup with a core average delayed neutron fraction of 0.007. The operator then adds positive reactivity to establish a stable 0.5 dpm startup rate.

If the core average delayed neutron fraction had been 0.005, what would be the approximate stable startup rate after the addition of the same amount of positive reactivity?

- A. 0.6
- B. 0.66
- C. 0.7
- D. 0.76

USNRC GENERIC FUNDAMENTALS EXAMINATION
SEPTEMBER 2005 PWR--FORM A

QUESTION: 35

Refer to the drawing that shows two graphs (see figure below). The axes on each graph have linear scales.

A nuclear reactor is initially critical in the source range. At time = 0 seconds, a constant rate addition of positive reactivity commences. Assume reactor power remains below the point of adding heat for the entire time interval shown.

The general response of startup rate to this event is shown on graph ____; and the general response of reactor power to this event is shown on graph _____. (Note: Either graph may be chosen once, twice, or not at all.)

- A. A; A
- B. A; B
- C. B; A
- D. B; B

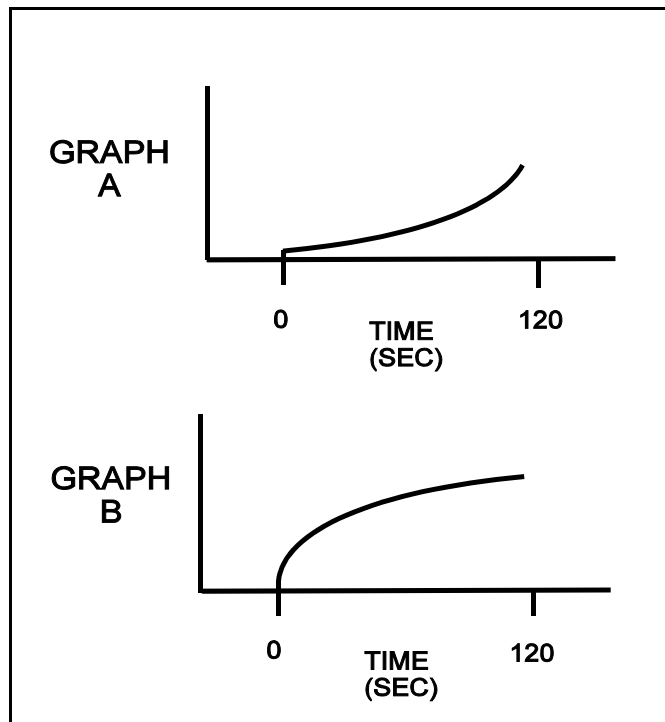

**USNRC GENERIC FUNDAMENTALS EXAMINATION
SEPTEMBER 2005 PWR--FORM A**

QUESTION: 36

Which one of the following describes the process for inserting control rods during a normal reactor shutdown?

- A. Control rods are inserted in reverse order one bank at a time to maintain acceptable power distribution.
- B. Control rods are inserted in reverse order one bank at a time to maintain a rapid shutdown capability from the remainder of the control rods.
- C. Control rods are inserted in reverse order in a bank overlapping sequence to maintain a relatively constant differential control rod worth.
- D. Control rods are inserted in reverse order in a bank overlapping sequence to limit the amount of positive reactivity added during a rod ejection accident.

QUESTION: 37

A water storage tank is vented to atmosphere. The tank is located at sea level and contains 100,000 gallons of water at 80°F. A pressure gauge at the bottom of the tank reads 9.0 psig. What is the approximate water level in the tank?

- A. 13 feet
- B. 17 feet
- C. 21 feet
- D. 25 feet

**USNRC GENERIC FUNDAMENTALS EXAMINATION
SEPTEMBER 2005 PWR--FORM A**

QUESTION: 38

A nuclear reactor is operating normally at 100% power. Reactor coolant enters the reactor vessel at a temperature of 556°F and a total flow rate of 320,000 gpm. The reactor coolant leaves the reactor vessel at 612°F.

What is the approximate flow rate of the reactor coolant leaving the reactor vessel?

- A. 320,000 to 329,000 gpm
- B. 330,000 to 339,000 gpm
- C. 340,000 to 349,000 gpm
- D. 350,000 to 359,000 gpm

QUESTION: 39

Consider a saturated water/steam mixture at 500°F with a quality of 90%. If the pressure of the mixture is decreased with no heat gain or loss, the temperature of the mixture will _____ and the quality of the mixture will _____. (Assume the mixture remains saturated.)

- A. decrease; decrease
- B. decrease; increase
- C. remain the same; decrease
- D. remain the same; increase

**USNRC GENERIC FUNDAMENTALS EXAMINATION
SEPTEMBER 2005 PWR--FORM A**

QUESTION: 40

Refer to the drawing of two 1,000 ft³ pressure vessels with relief protection (see figure below).

Both vessels are in saturated conditions at 281°F and approximately 35 psig. Vessel A is completely filled with saturated water. Vessel B contains one-half saturated steam (100% quality) volume and one-half saturated water (0% quality) volume. Both vessels are protected by identical relief valves.

If both relief valves begin to leak at a rate of 0.1% of design flow, the higher temperature fluid will initially be leaving the relief valve of vessel _____. And, if 100 lbm of fluid is released through both relief valves, the larger pressure decrease will occur in vessel _____.

- A. A; A
- B. A; B
- C. B; A
- D. B; B

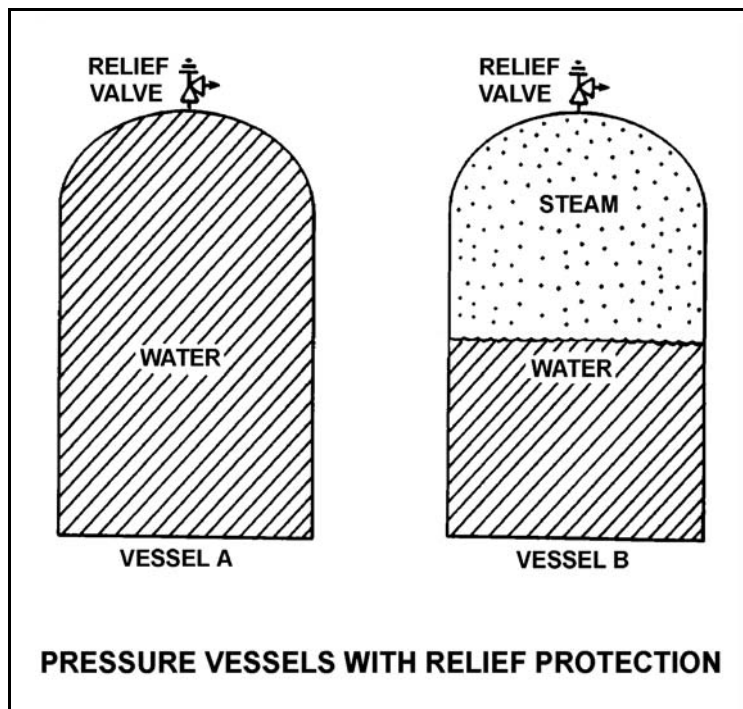

**USNRC GENERIC FUNDAMENTALS EXAMINATION
SEPTEMBER 2005 PWR--FORM A**

QUESTION: 41

The theoretical maximum efficiency of a steam cycle is given by the equation:

$$\text{Eff}_{\text{thmax}} = (1 - T_{\text{out}}/T_{\text{in}}) \times 100\%,$$

where T_{out} is the absolute temperature for heat rejection and T_{in} is the absolute temperature for heat addition. (Fahrenheit temperature is converted to absolute temperature by adding 460E.)

A nuclear power plant is operating with a stable steam generator pressure of 900 psia. What is the approximate theoretical maximum steam cycle efficiency this plant can achieve by establishing its main condenser vacuum at 1.0 psia?

- A. 35%
- B. 43%
- C. 57%
- D. 65%

QUESTION: 42

Which one of the following describes the relationship between the main steam mass flow rate leaving a steam generator and the main feedwater mass flow rate entering the same steam generator at steady-state power operation? (Assume no auxiliary addition/removal of steam generator inventory.)

- A. The mass flow rates will be the same only if downcomer level is constant.
- B. The mass flow rates will be the same only if the reactor is operating near rated power.
- C. The main steam mass flow rate is smaller than the main feedwater mass flow rate by the amount of moisture removed by the steam generator moisture separators.
- D. The main steam mass flow rate is greater than the main feedwater mass flow rate by the amount of moisture removed by the steam generator moisture separators.

**USNRC GENERIC FUNDAMENTALS EXAMINATION
SEPTEMBER 2005 PWR--FORM A**

QUESTION: 43

Refer to the drawing of a main water header that splits into two parallel headers (see figure below).

Header A has a 2-inch diameter and header B has a 3-inch diameter. The velocity of the water in both headers is the same.

If the main water header has a flow rate of 500 gpm, what is the approximate flow rate in each of the parallel headers?

	HEADER A (gpm)	HEADER B (gpm)
A.	125	375
B.	154	346
C.	200	300
D.	222	278

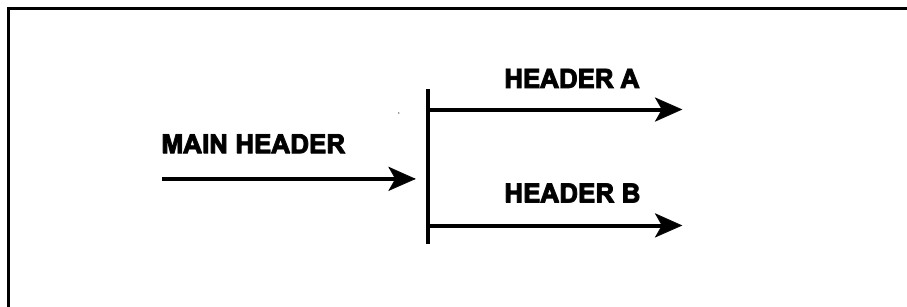

**USNRC GENERIC FUNDAMENTALS EXAMINATION
SEPTEMBER 2005 PWR--FORM A**

QUESTION: 44

Which one of the following pairs of fluids undergoing heat transfer in typical cross-flow design heat exchangers will yield the greatest heat exchanger overall heat transfer coefficient?

- A. Oil to water in a lube oil cooler
- B. Air to water in an air compressor after-cooler
- C. Steam to water in a turbine exhaust steam condenser
- D. Water to water in a cooling water heat exchanger

QUESTION: 45

A nuclear power plant is operating with the following initial conditions:

- Reactor power is 55% in the middle of a fuel cycle.
- Axial and radial power distributions are peaked in the center of the core.

Which one of the following will decrease the steady-state departure from nucleate boiling ratio?

- A. A reactor trip occurs and one control rod remains fully withdrawn from the core.
- B. A pressurizer malfunction increases reactor coolant system pressure by 20 psig.
- C. The operator increases reactor coolant boron concentration by 5 ppm with no rod motion.
- D. Core Xe-135 depletes in proportion to the axial and radial power distribution with no rod motion.

**USNRC GENERIC FUNDAMENTALS EXAMINATION
SEPTEMBER 2005 PWR--FORM A**

QUESTION: 46

Increasing coolant flow rate through the nuclear reactor core improves heat transfer from the fuel because it _____ the laminar film thickness and _____ the temperature of the coolant adjacent to the fuel.

- A. increases; increases
- B. increases; decreases
- C. decreases; increases
- D. decreases; decreases

**USNRC GENERIC FUNDAMENTALS EXAMINATION
SEPTEMBER 2005 PWR--FORM A**

QUESTION: 47

Refer to the drawing of a fuel rod and coolant flow channel at the beginning of a fuel cycle (see figure below).

At 100% reactor power, the greatest temperature difference in a fuel channel radial temperature profile will occur across the: (Assume the temperature profile begins at the fuel centerline.)

- A. fuel pellet centerline to pellet surface.
- B. fuel pellet surface-to-clad gap.
- C. zircaloy cladding.
- D. flow channel boundary (laminar) layer.

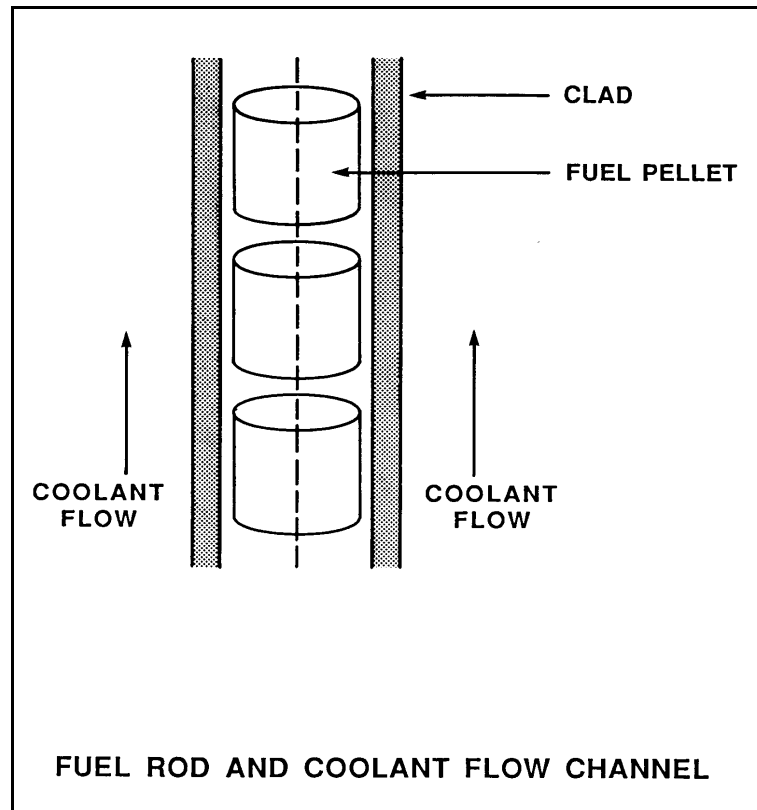

**USNRC GENERIC FUNDAMENTALS EXAMINATION
SEPTEMBER 2005 PWR--FORM A**

QUESTION: 48

A nuclear reactor is shut down at normal operating temperature and pressure with all reactor coolant pumps stopped. Stable natural circulation cooling is in progress with 50°F of RCS subcooling. Which one of the following, if increased, will not affect natural circulation flow rate?

- A. Reactor coolant pressure
- B. Time after reactor trip
- C. Feed water flow rate
- D. Steam generator pressure

QUESTION: 49

A nuclear reactor is operating at steady state 80% reactor power with core power distribution peaked both radially and axially in the center of the core. Reactor coolant boron concentration changes are used to maintain a constant T_{ave} and control rod position does not change.

Neglecting any change in fission product poison distribution, during the next three months the maximum radial peaking factor will _____ and the maximum axial peaking factor will _____.

- A. increase; decrease
- B. increase; increase
- C. decrease; decrease
- D. decrease; increase

**USNRC GENERIC FUNDAMENTALS EXAMINATION
SEPTEMBER 2005 PWR--FORM A**

QUESTION: 50

A nuclear reactor is shut down for refueling following 18 months of operation at an average power level of 85%. During the shutdown, a reactor vessel metal specimen was removed from the reactor vessel for testing. The tests determined that the nil-ductility transition (NDT) temperature of the specimen has increased from 42°F to 72°F since the previous refueling shutdown.

Which one of the following conclusions is warranted?

- A. The test results are credible and the reactor vessel is more likely to experience brittle fracture now than after the previous refueling shutdown.
- B. The test results are credible and the reactor vessel is less likely to experience brittle fracture now than after the previous refueling shutdown.
- C. The test results are questionable because the specimen NDT temperature would not increase during the described 18-month period of operation.
- D. The test results are questionable because the specimen NDT temperature would increase by less than indicated during the described 18-month period of operation.

***** FINAL ANSWER KEY *****

**SEPTEMBER 2005 NRC GENERIC FUNDAMENTALS EXAMINATION
PRESSURIZED WATER REACTOR - ANSWER KEY**

<u>FORM A</u>	<u>FORM B</u>	<u>ANS.</u>	<u>FORM A</u>	<u>FORM B</u>	<u>ANS.</u>
1	15	A	26	40	A
2	16	A	27	41	C
3	17	B	28	42	A
4	18	B	29	43	B
5	19	D	30	44	A
6	20	B	31	45	C
7	21	D	32	46	C
8	22	D	33	47	A
9	23	C	34	48	D
10	24	C	35	49	A
11	25	D	36	50	C
12	26	B	37	1	C
13	27	B	38	2	D
14	28	C	39	3	B
15	29	A	40	4	D
16	30	C	41	5	B
17	31	B	42	6	A
18	32	B	43	7	B
19	33	C	44	8	C
20	34	A	45	9	D
21	35	D	46	10	D
22	36	B	47	11	A
23	37	B	48	12	A
24	38	C	49	13	C
25	39	D	50	14	D