

Attachment N

(Calculation E4C-090, ICCN C-130)

Proposed Interim Change (219.5 kV)

SONGS Units 2 and 3

Southern California Edison Company <b>INTERIM CALCULATION          CHANGE NOTICE (ICCN)/          CALCULATION CHANGE          NOTICE (CCN)          COVER PAGE</b> SUMMARY CHANGE <input type="checkbox"/> NO <input checked="" type="checkbox"/> YES	CALC NO. <b>E4C-090</b>		ICCN NO./ PRELIM. CCN NO. <b>C - 130</b>	PAGE <b>1</b>	TOTAL NO. OF PAGES <b>64</b>
	BASE CALC. REV. <b>3</b>	UNIT <b>3</b>	CCN CONVERSION: CCN NO. <b>CCN-</b>	CALC. REV.	
	CALCULATION SUBJECT: <b>AUXILIARY SYSTEM VOLTAGE REGULATION</b>				
CALCULATION CROSS-INDEX <input checked="" type="checkbox"/> New/Updated Index Included <input type="checkbox"/> Existing Index is Complete	ENGINEERING SYSTEM NUMBER/PRIMARY STATION SYSTEM DESIGNATOR <b>1804 / PBA</b>			Q-CLASS <b>II</b>	
Site Programs / Procedure Impact? <input checked="" type="checkbox"/> NO <input type="checkbox"/> YES, AR No.	CONTROLLED PROGRAM OR DATABASE ACCORDING TO SO123-XXIV-5.1 <input checked="" type="checkbox"/> PROGRAM <input type="checkbox"/> DATABASE		PROGRAM/DATABASE NAME(S) <input type="checkbox"/> ALSO, LISTED BELOW <b>ETAP</b>	VERSION/RELEASE NO.(S) <b>5.0.0N</b>	
10CFR50.59/72.48 Review: AR No. <b>N/A - See PCN 561</b>					

**1. BRIEF DESCRIPTION OF ICCN/CCN:**

Purpose

This summary change ICCN supports ECP 050500255 – 34 and provides the basis for the revised setting for the Degraded Grid Voltage (DGV) Relay Setpoint for Class 1E bus 3A04. NCDBMEL identification numbers for these relays are 3A0420-127D-1, 3A0420-127D-2, 3A0420-127D-3, and 3A0420-127D-4. This ICCN also supports PCN 561.

Specifically, this ICCN defines the design voltage limit at the 4.16kV bus 3A04 based on a postulated switchyard voltage of 219.5kV. This value is then utilized in the DGV relay setpoint calculation E4C-130. The analysis focuses on the Class 1E system only.

Acceptance Criteria

For this ICCN, the Class 1E 4.16kV bus voltage is determined based on a postulated switchyard voltage of 219.5kV (see methodology on page 3). This value will be used to determine the maximum DGV relay reset (pickup) value indicated in calculation E4C-130 Rev. 1, ICCN C – 3. This value represents an output parameter of this calculation, and is not associated with a specific acceptance criterion.

For the study cases performed at the minimum DGV relay dropout setpoint, Class 1E loads are expected to have a minimum terminal voltage of 90% rated, consistent with the base calculation Section 1.3.

Results and Conclusions

The resultant 3A04 bus voltage derived in this ICCN is 4190V based on a postulated switchyard voltage of 219.5kV. In addition, all Class 1E loads experience a minimum terminal voltage greater than 90% rated, with 3A04 bus voltage at 4139V.

(continued on page 3)

INITIATING DOCUMENT (ECP, OTHER) ECP 050500255 – 34 Rev. 0

**2. OTHER AFFECTED DOCUMENTS (CHECK AS APPLICABLE FOR CCN ONLY);**

YES  NO OTHER AFFECTED DOCUMENTS EXIST AND ARE IDENTIFIED ON ATTACHED FORM 26-503.

**3. APPROVED BY:**

W. P. Lennartz W.P. Lennartz 5/26/05

ORIGINATOR (Print name/sign/date)  
 Approval requires PQS T3EN64 Qualification Verified: WPL  
 Initial

DISCIPLINE / ESC: Electrical / DEO

[Signature] 5/26/05

FLS (Signature/date)  
 Approval requires PQS T3EN64 Qualification Verified: [Signature]  
 Initial

J. I. Kim J. I. Kim 5/26/05

IRE (Print name/sign/date)  
 Approval requires PQS T3EN64 Qualification Verified: JIK  
 Initial

**4. CONVERSION TO CCN DATE** \_\_\_\_\_

SCE CDM-SONGS

# CALCULATION CROSS-INDEX

Calculation No. E4C-090

Sheet \_\_\_\_\_ of \_\_\_\_\_

CCN CONVERSION: CCN NO. <b>CCN--</b>
---

Calc. rev. number and responsible FLS initials and date	INPUTS <small>These interfacing calculations and/or documents provide input to the subject calculation, and if revised may require revision of the subject calculation.</small>		OUTPUTS <small>Results and conclusion of the subject calculation are used in these interfacing calculations and/or documents.</small>		Does the output interface calc/document require Change?	Identify output interface calc/document <small>CCN, ECP, TCN/Rev., or tracking number.</small>
	Calc / Document No.	Rev. No.	Calc / Document No.	Rev. No.	YES / NO	
Rev. 3 ICCN C-130  <i>ICW</i> <i>5/26/05</i>	ECP 050500255 - 34 90042, ECN A36442 E4C - 130, ICCN C - 3	0 10 1	E4C - 130	1	YES	ICCN C - 3

E&TS DEPARTMENT  
**CALCULATION SHEET**

ICCN NO./- PRELIM. CCN NO.	<b>C - 130</b>	Page <u>3</u> of <u>64</u>
-------------------------------	----------------	----------------------------

Project or ECP ECP 050500255 - 34 Calc No. E4C - 090  
 Subject AUXILIARY SYSTEM VOLTAGE REGULATION

CCN CONVERSION: CCN NO. CCN
--------------------------------

Sheet \_\_\_\_\_ of \_\_\_\_\_

REV	ORIGINATOR	DATE	IRE	DATE	REV	ORIGINATOR	DATE	IRE	DATE	REV INDICATOR
3										

Assumptions

There are no specific assumptions associated with this ICCN.

Design Input

The minimum DGV relay dropout setpoint is derived from calculation E4C-130 Rev. 1, ICCN C-3, Table 2.1.5. This value is 4139.7V.

Relative to the base calculation study cases, the analysis included in this ICCN conservatively postulates that the Unit 3 Train A Emergency Diesel Generator ancillary loads are operating (as described in AR 050201584 - 4) while connected to the offsite source. Refer to base calculation case 3A12a for postulated loading. Otherwise, the study case in this ICCN is similar to case 3A14 of the base calculation. This is the limiting study case for the accident scenario (see also methodology below) as described in the base calculation.

Methodology

This ICCN includes accident scenario analyses only, similar to base calculation study case 3A14. However, only the affected safety train is analyzed (Unit 3, Train A) to support associated ECP. The included study case is designated as "3A14aa".

This ICCN provides a resultant 4.16kV bus voltage level based on a postulated switchyard voltage of 219.5kV. The 4.16kV bus voltage will then be utilized for DGV relay maximum reset (pickup) design limit included in calculation E4C-130 Rev. 1, ICCN C-3. This setpoint will then ensure that the 4.16kV bus remains connected to the normal preferred (offsite) power source during the post-accident, post-load-sequencing period.

The minimum DGV relay dropout setpoint (4139.7V) derived in E4C-130 Rev. 1, ICCN C-3, Table 2.1.5 is utilized in this analysis to confirm Class 1E equipment operability. The analysis in this ICCN utilizes a bounding (lower) value of 4139V.

Page 4 of this ICCN includes the one-line diagram of the analyzed system.

The case where the Class 1E 4.16kV buses are cross-tied to Unit 2 (alternate preferred source) is not analyzed in this ICCN because the cross-tie condition places the operating unit in an action statement due to the connection to the alternate preferred source. The alternate preferred source at 219.5kV may not be capable of providing adequate voltage at the 4.16kV bus immediately after the trip event.

Calculation

ETAP load flow is utilized to ascertain the 4.16kV voltage level with a switchyard voltage of 219.5kV. The report is included in this ICCN on pages 5 through 34. The minimum DGV relay setpoint analysis is included on pages 35 through 64.

# E&TS DEPARTMENT CALCULATION SHEET

ICCN NO./  
PRELIM. CCN NO.

C - 130

Page 4 of 64

Project or ECP ECP 050500255 - 34 Calc No. E4C - 090  
 Subject AUXILIARY SYSTEM VOLTAGE REGULATION

CCN CONVERSION:  
CCN NO. CCN

Sheet      of     

REV	ORIGINATOR	DATE	IRE	DATE	REV	ORIGINATOR	DATE	IRE	DATE
3									
REV INDICATOR									

## BUS ALIGNMENT AND LOADING DIAGRAM CASE 3A14aa

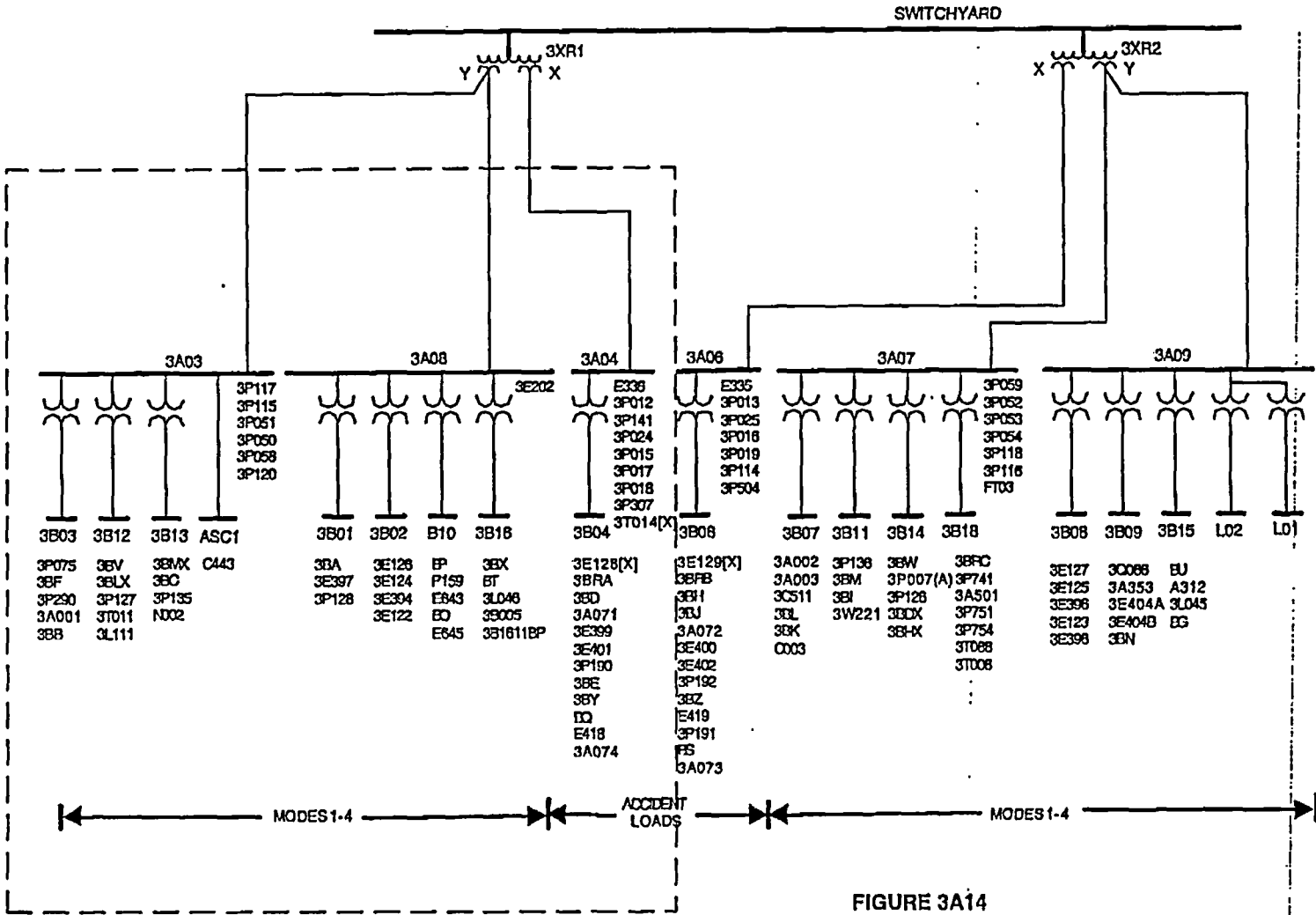

FIGURE 3A14

**AUXILIARY SYSTEM VOLTAGE REGULATION**

**ICCN C - 130**

CCN No. \_\_\_\_\_

Project: E4C-090 REV. 3 ICCN C - 130

ETAP

Page: 1

Location: SONGS 2 & 3

5.0.0N

Date: 05-25-2005

Contract:

SN: SCALEDISON

Engineer: W.P. Lennartz

Study Case: 3A14aa

Revision: Base

Filename: E4C090

Config.: 090-3A14aa

ECP 050500255 - 34 ICCN C - 130 UNIT 3 TRAIN A

Electrical Transient Analyzer Program

Load Flow Analysis

Loading Category (1): Design-BHP

Generation Category (1): Design

Load Diversity Factor: None

	<u>Swing</u>	<u>V-Control</u>	<u>Load</u>	<u>Total</u>
Number of Buses:	5	0	75	80

	<u>XFMR2</u>	<u>XFMR3</u>	<u>Reactor</u>	<u>Line/Cable</u>	<u>Impedance</u>	<u>Tie PD</u>	<u>Total</u>
Number of Branches:	8	1	0	41	0	24	74

Method of Solution: Newton-Raphson Method

Maximum No. of Iteration: 10

Precision of Solution: 0.001000

System Frequency: 60 Hz

Unit System: English

Project Filename: E4C090

Output Filename: C:\hvp\files\ETAPDATA\086-088-090\3A14aa219-5.lfr

AUXILIARY SYSTEM VOLTAGE REGULATION

ICCN C - 130

CCN No. \_\_\_\_\_

Project: E4C-090 REV.3 ICCN C-130

ETAP

Page: 2

Location: SONGS 2 & 3

5.0.0N

Date: 05-25-2005

Contract:

SN: SCALEDISON

Engineer: W. P. Lennartz

Study Case: 3A14aa

Revision: Base

Filename: E4C090

Config.: 090-3A14aa

ECP 050500255 - 34 ICCN C - 130 UNIT 3 TRAIN A

Adjustments

<u>Tolerance</u>	<u>Apply Adjustments</u>	<u>Individual /Global</u>	<u>Percent</u>
Transformer Impedance:	Yes	Individual	
Reactor Impedance:	Yes	Individual	
Overload Heater Resistance:	No		
Transmission Line Length:	No		
Cable Length:	No		

<u>Temperature Correction</u>	<u>Apply Adjustments</u>	<u>Individual /Global</u>	<u>Degree C</u>
Transmission Line Resistance:	Yes	Individual	
Cable Resistance:	Yes	Individual	

AUXILIARY SYSTEM VOLTAGE REGULATION

ICCN C - 130

CCN No. \_\_\_\_\_

Project: E4C-090 REV,3 ICCN C-130

ETAP

Page: 3

Location: SONGS 2 & 3

5.0.0N

Date: 05-25-2005

Contract:

SN: SCALEDISON

Engineer: W. P. Lennartz

Study Case: 3A14aa

Revision: Base

Filename: E4C090

Config.: 090-3A14aa

ECP 050500255 - 34 ICCN C - 130 UNIT 3 TRAIN A

Bus Input Data

Bus			Initial Voltage		Load							
ID	kV	Sub-sys	% Mag.	Ang.	Constant kVA		Constant Z		Constant I		Generic	
					MW	Mvar	MW	Mvar	MW	Mvar	MW	Mvar
2G002-BUS	4.160	2	105.3	0.0								
2G003-BUS	4.160	3	105.3	0.0								
3A03	4.160	1	97.8	-4.0	10.000	5.865						
3A04	4.160	1	100.7	-1.6	2.596	1.294	0.127	0.079				
3A08	4.160	1	97.8	-4.0	0.796	0.339						
3B01	0.480	1	93.6	-5.4	0.131	0.078						
3B01XH5	4.160	1	97.8	-4.0								
3B02	0.480	1	96.5	-6.8	0.049	0.031						
3B02XH5	4.160	1	97.8	-4.0								
3B03	0.480	1	94.5	-6.9	0.206	0.120						
3B03XH5	4.160	1	97.8	-4.0								
3B04	0.480	1	94.7	-5.9	0.261	0.172						
3B04XH5	4.160	1	100.7	-1.6								
3B12	0.480	1	93.7	-7.7	0.202	0.118	0.141	0.047				
3B12XH5	4.160	1	97.8	-4.0								
3B13	0.480	1	96.0	-5.9	0.151	0.079	0.082	0.031				
3B13XH5	4.160	1	97.8	-4.0								
3B16	0.480	1	93.0	-7.6	0.089	0.043	0.084	0.078				
3B16XH5	4.160	1	97.8	-4.0								
3B1611BP	0.480	1	91.1	-7.7	0.006	0.004	0.143	0.125				
3BA	0.480	1	93.3	-5.6	0.153	0.097	0.129	0.049				
3BB	0.480	1	91.9	-7.5	0.138	0.087	0.024	0.006				
3BC	0.480	1	94.9	-6.1	0.041	0.030	0.073	0.036				
3BD	0.480	1	90.7	-6.4	0.130	0.088						
3BD18-HTRS	0.480	1	90.7	-6.4								
3BDMM	0.460	1	94.6	-6.4	0.005	0.003						
3BD5M	0.480	1	90.7	-6.4			0.004	0.003				
3BE	0.480	1	94.6	-5.9	0.001	0.001	0.084	0.042				
3BEMM	0.460	1	98.8	-5.9	0.005	0.003						
3BESM	0.480	1	94.6	-5.9			0.004	0.003				
3BF	0.480	1	92.8	-7.6	0.104	0.052	0.156	0.059				
3BHP01	0.480	1	95.9	-7.0			0.157	0.030				
3BHP02	0.480	1	96.1	-7.0			0.210	0.000				
3BHP03	0.480	1	96.1	-7.0			0.210	0.000				



AUXILIARY SYSTEM VOLTAGE REGULATION

ICCN C - 130

CCN No. \_\_\_\_\_

Project: E4C-090 REV.3 ICCN C-130

ETAP

Page: 4

Location: SONGS 2 & 3

5.0.0N

Date: 05-25-2005

Contract:

SN: SCALEDISON

Engineer: W.P. Lennartz

Study Case: 3A14aa

Revision: Base

Filename: EAC090

Config.: 090-3A14aa

ECP 050500255-34 ICCN C-130 UNIT 3 TRAIN A

Bus			Initial Voltage		Load							
ID	kV	Sub-sys	% Mag.	Ang.	Constant kVA		Constant Z		Constant I		Generic	
					MW	Mvar	MW	Mvar	MW	Mvar	MW	Mvar
3BHP04	0.480	1	93.7	-6.6			0.210	0.000				
3BLX	0.480	1	93.1	-7.9	0.036	0.023	0.018	0.005				
3BMX	0.480	1	95.8	-5.9	0.035	0.022	0.018	0.005				
3BRA	0.480	1	94.7	-5.9								
3BRAMM	0.460	1	98.8	-5.9	0.005	0.003						
3BRASM	0.480	1	94.7	-5.9			0.004	0.003				
3BV	0.480	J	92.7	-8.0	0.101	0.073	0.119	0.059				
3BX	0.480	1	91.5	-8.2	0.107	0.070	0.238	0.083				
3BY	0.480	1	94.6	-6.0	0.139	0.082	0.061	0.048				
3BY39-HTRS	0.480	1	94.6	-6.0			0.008	0.030				
3BY40-HTRS	0.480	1	94.6	-6.0			0.003	0.000				
3BYMM	0.460	1	98.7	-6.0	0.005	0.003						
3BYSM	0.480	1	94.6	-6.0			0.004	0.003				
3D004-3A0409	4.160	1	100.7	-1.6								
3D004-3P018	4.160	1	100.7	-1.6	0.408	0.174						
3G002-BUS	4.160	5	105.3	0.0								
3G003-BUS	4.160	4	105.3	0.0								
3HV9377-N	0.480	1	94.6	-5.9			0.002	0.001				
3L111	0.480	1	90.4	-8.6	0.125	0.049	0.062	0.024				
3L707-3BRAC6	0.480	1	94.6	-5.9								
3PEXCC5	4.160	1	97.7	-4.0	1.770	0.907						
3Q020	0.480	1	90.7	-6.4			0.004	0.003				
3Q039	0.480	1	94.6	-6.0			0.017	0.011				
3Q074	0.480	1	94.7	-5.9			0.004	0.003				
3TD63	0.480	1	94.6	-5.9			0.021	0.013				
3XR1-X	4.160	1	100.9	-1.5								
3XR1-Y	4.160	1	98.1	-4.0								
ASCI	4.160	1	97.8	-4.0	0.232	0.115						
B10	0.480	1	95.6	-6.5	0.063	0.040	0.090	0.000				
B10XBHS	4.160	1	97.8	-4.0								
BO	0.480	1	95.1	-7.0	0.021	0.014	0.286	0.020				
BP	0.480	1	94.5	-6.9	0.163	0.108	0.125	0.040				
BQ	0.480	1	93.9	-6.0	0.061	0.038	0.054	0.030				
BQMM	0.460	1	98.0	-6.0	0.005	0.003						
BQSM	0.480	1	93.9	-6.0			0.004	0.003				
BT	0.480	1	90.7	-8.0	0.168	0.100	0.246	0.127				

AUXILIARY SYSTEM VOLTAGE REGULATION

ICCN C - 130

CCN No. \_\_\_\_\_

Project: E4C-090 REV.3 ICCN C-130

ETAP

Page: 5

Location: SONGS 2 & 3

5.0.0N

Date: 05-25-2005

Contract:

SN: SCALEDISON

Engineer: W. P. Lennartz

Study Case: 3A14aa

Revision: Base

Filename: E4C090

Config.: 090-3A14aa

ECP 050500255 - 34 ICCN C-130 UNIT 3 TRAIN A

Bus			Initial Voltage		Load							
ID	kV	Sub-sys	% Mag.	Ang.	Constant kVA		Constant Z		Constant I		Generic	
					MW	Mvar	MW	Mvar	MW	Mvar	MW	Mvar
BT-3B1603	0.480	1	90.7	-8.0								
D007-3A0402	4.160	1	100.7	-1.6								
D007-E336	4.160	1	100.7	-1.6	0.456	0.256						
D645	0.480	1	95.4	-6.6			0.009	0.000				
DB0415-3B0418	0.480	1	93.9	-5.9								
DB0415-E418	0.480	1	93.9	-5.9	0.111	0.071						
Q033	0.480	1	93.9	-6.0			0.013	0.008				
SWITCHYARD	230.000	1	95.4	0.0								
SWITCHYARD-3	230.000	1	95.4	0.0								
ZTB45	0.480	1	95.4	-6.6								
Total Number of Buses: 80					19.072	10.655	3.245	1.015	0.000	0.000	0.000	0.000

Generation Bus				Voltage		Generation			Mvar Limits	
ID	kV	Type	Sub-sys	% Mag.	Angle	MW	Mvar	% PF	Max	Min
2G002-BUS	4.160	Swing	2	105.3	0.0					
2G003-BUS	4.160	Swing	3	105.3	0.0					
3G002-BUS	4.160	Swing	5	105.3	0.0					
3G003-BUS	4.160	Swing	4	105.3	0.0					
SWITCHYARD	230.000	Swing	1	95.4	0.0					
						0.000	0.000			

AUXILIARY SYSTEM VOLTAGE REGULATION

ICCN C - 130

CCN No. \_\_\_\_\_

Project: E4C-090 REV. 3 ICCN C - 130

ETAP

Page: 6

Location: SONGS 2 & 3

5.0.0N

Date: 05-25-2005

Contract:

SN: SCALEDISON

Engineer: W. P. Lennartz

Study Case: 3A14aa

Revision: Base

Filename: E4C090

Config.: 090-3A14aa

ECP 050500255 - 34 ICCN C - 130 UNIT 3 TRAIN A

Line/Cable Input Data

Ohms or Siemens/1000 ft per Conductor (Cable) or per Phase (Line)

Line/Cable ID	Library	Size	Length		#/Phase	T (°C)	R	X	Y
			Adj. (ft)	% Tol.					
0XB1002P1	0.6MCUN1	750	175.0	0.0	1	75	0.028000	0.043800	
0XB1014P1	0.6MCUN1	750	131.0	0.0	1	75	0.028000	0.043800	
0XB1015P1	0.6MCUN1	1/0	378.0	0.0	1	75	0.131000	0.049500	
0XB1015P2	0.6MCUN1	6	20.0	0.0	1	75	0.498000	0.059800	
3AA0402P1	8.0MCUN3	250	48.0	0.0	1	75	0.054700	0.035600	
3AA0409P1	8.0MCUN3	250	278.0	0.0	1	75	0.054700	0.035600	
3AA0417P1	8.0MCUN3	250	70.0	0.0	1	75	0.054700	0.035600	
3AB0403P1	0.6MCUN1	350	31.0	0.0	1	75	0.046100	0.046900	
3AB0407P1	0.6MCUN1	350	765.0	0.0	1	75	0.046100	0.046900	
3AB0414P1	0.6MCUN1	350	31.0	0.0	1	75	0.046100	0.046900	
3AB0415P1	0.6MCUN1	750	31.0	0.0	1	75	0.028000	0.043800	
3AB0417P1	0.6MCUN1	350	181.0	0.0	1	75	0.046100	0.046900	
3AB0418P1	0.6MCUN1	3/0	148.0	0.0	1	75	0.086000	0.048600	
3ABRA06P1	0.6MCUN3	10	125.0	0.0	1	75	1.240000	0.044300	
3XA0304P1	8.0MCUN3	250	66.0	0.0	1	75	0.054700	0.035600	
3XA0309P1	8.0MCUN3	250	224.0	0.0	1	75	0.054700	0.035600	
3XA0310P1	8.0MCUN3	250	60.0	0.0	1	75	0.054700	0.035600	
3XA0311P1	8.0MCUN3	250	40.0	0.0	1	75	0.054700	0.035600	
3XA0312P1	8.0MCUN3	350	240.0	0.0	1	75	0.040000	0.034800	
3XA0801P1	8.0MCUN3	250	170.0	0.0	1	75	0.054700	0.035600	
3XA0802P1	8.0MCUN3	250	60.0	0.0	1	75	0.054700	0.035600	
3XA0808P1	8.0MCUN3	250	203.0	0.0	1	75	0.054700	0.035600	
3XA0809P1	8.0MCUN3	250	232.0	0.0	1	75	0.054700	0.035600	
3XB0102P1	0.6MCUN1	750	56.0	0.0	1	75	0.028000	0.043800	
3XB0205P1	0.6MCUN1	4/0	66.0	0.0	1	75	0.070000	0.048200	
3XB0206P1	0.6MCUN1	4/0	66.0	0.0	1	75	0.070000	0.048200	
3XB0210P1,P2	0.6MCUN1	2/0	83.0	0.0	1	75	0.106000	0.049000	
3XB0306P1	0.6MCUN1	750	314.0	0.0	1	75	0.028000	0.043800	
3XB0314P1	0.6MCUN1	500	549.0	0.0	1	75	0.035900	0.045000	
3XB0402P1	0.6MCUN1	350	268.0	0.0	1	75	0.046100	0.046900	
3XB1202P1	0.6MCUN1	750	181.0	0.0	1	75	0.028000	0.043800	
3XB1203P1	0.6MCUN1	500	377.0	0.0	1	75	0.035900	0.045000	
3XB1211P1	0.6MCUN1	350	605.0	0.0	1	75	0.046100	0.046900	
3XB1303P1	0.6MCUN1	500	189.0	0.0	1	75	0.035900	0.045000	

AUXILIARY SYSTEM VOLTAGE REGULATION

ICCN C - 130

CCN No. \_\_\_\_\_

Project: E4C-090 REV.3 ICCN C-130

ETAP

Page: 7

Location: SONGS 2 & 3

5.0.0N

Date: 05-25-2005

Contract:

SN: SCALEDISON

Engineer: W. P. Lennartz

Study Case: 3A14aa

Revision: Base

Filename: E4C090

Config.: 090-3A14aa

ECP 050500255 - 34 ICCN C-130 UNIT 3 TRAIN A

Ohms or Siemens/1000 ft per Conductor (Cable) or per Phase (Line)

Line/Cable ID	Library	Size	Length		#/Phase	T (°C)	R	X	Y
			Adj. (ft)	% Tol.					
3XB1305P1	0.6MCUN1	500	380.0	0.0	1	75	0.035900	0.045000	
3XB1602P1	0.6MCUN1	750	224.0	0.0	1	75	0.028000	0.043800	
3XB1603P1.P2	0.6MCUN1	350	371.0	0.0	2	75	0.046100	0.046900	
3XB1611P1	0.6MCUN1	350	370.0	0.0	1	75	0.046100	0.046900	
3XXR169P1-P3	8.0MCUN3	750	631.0	0.0	3	75	0.020800	0.030900	
3XXR169P7.P8	8.0MCUN3	750	610.0	0.0	2	75	0.020800	0.030900	
3XXR169PA-PD.P9	8.0MCUN3	750	374.0	0.0	5	75	0.020800	0.030900	

Line / Cable resistances are listed at the specified temperatures.

AUXILIARY SYSTEM VOLTAGE REGULATION

ICCN C - 130

CCN No. \_\_\_\_\_

Project: E4C-090 REV.3 ICCN C-130  
 Location: SONGS 2 & 3  
 Contract:  
 Engineer: W. P. Lennartz  
 Filename: E4C090

ETAP  
 5.0.0N

Study Case: 3A14aa

Page: 8  
 Date: 05-25-2005  
 SN: SCALEDISON  
 Revision: Base  
 Config.: 090-3A14aa

ECP 050500255 - 34 ICCN C-130 UNIT 3 TRAIN A

2-Winding Transformer Input Data

Transformer ID	Rating			Z Variation			% Tap Setting		Adjusted	Phase Shift			
	MVA	Prim. kV	Sec. kV	% Z	X/R	+5%	-5%	% Tol.	Prim.	Sec.	% Z	Type	Angle
3B01X	1.500	4.160	0.480	9.09	6.80	0	0	0	2.500	0	9.0900	Std Pos. Seq.	0.0
3B02X	1.000	4.160	0.480	8.05	5.30	0	0	0	0	0	8.0500	Std Pos. Seq.	0.0
3B03X	1.000	4.160	0.480	8.09	10.92	0	0	0	0	0	8.0900	Std Pos. Seq.	0.0
3B04X	1.500	4.160	0.480	10.07	6.64	0	0	0	0	0	10.0700	Std Pos. Seq.	0.0
3B12X	1.000	4.160	0.480	8.14	11.08	0	0	0	0	0	8.1400	Std Pos. Seq.	0.0
3B13X	1.000	4.160	0.480	8.13	10.96	0	0	0	0	0	8.1300	Std Pos. Seq.	0.0
3B16X	1.500	4.160	0.480	9.33	8.75	0	0	0	0	0	9.3300	Std Pos. Seq.	0.0
B10X-B	1.500	4.160	0.480	9.17	6.72	0	0	0	0	0	9.1700	Std Pos. Seq.	0.0

3-Winding Transformer Input Data

Transformer ID	Winding	Rating		Tap	Impedance			Z Variation		Phase Shift		
		MVA	kV	%	% Z	X/R	MVA <sub>b</sub>	% Tol.	+5%	-5%	Type	Angle
3XRJ	Primary:	30.000	230.000	-2.50	Z <sub>ps</sub> = 14.40	20.67	30.000	0	0	0		
	Secondary:	10.000	4.360	0	Z <sub>pt</sub> = 11.10	22.80	30.000	0			Std Pos. Seq.	0.0
	Tertiary:	20.000	4.360	0	Z <sub>st</sub> = 24.60	19.16	30.000	0			Std Pos. Seq.	0.0

AUXILIARY SYSTEM VOLTAGE REGULATION

ICCN C - 130

CCN No. \_\_\_\_\_

Project: E4C-090 REV.3 ICCN C - 130  
 Location: SONGS 2 & 3  
 Contract:  
 Engineer: W. P. Lennartz  
 Filename: E4C090

ETAP  
 5.0.0N  
 Study Case: 3A14aa

Page: 9  
 Date: 05-25-2005  
 SN: SCALEDISON  
 Revision: Base  
 Config.: 090-3A14aa

ECP 050500255 - 34 ICCN C - 130 UNIT 3 TRAIN A

Branch Connections

CKT/Branch		Connected Bus ID		% Impedance, Pos. Seq., 100 MVA Base			
ID	Type	From Bus	To Bus	R	X	Z	Y
3B01X	2W XFMR	3B01XHS	3B01	82.27	559.45	565.47	
3B02X	2W XFMR	3B02XHS	3B02	135.87	720.13	732.84	
3B03X	2W XFMR	3B03XHS	3B03	67.16	733.41	736.48	
3B04X	2W XFMR	3B04XHS	3B04	91.02	604.34	611.16	
3B12X	2W XFMR	3B12XHS	3B12	66.61	738.03	741.03	
3B13X	2W XFMR	3B13XHS	3B13	67.25	737.06	740.12	
3B16X	2W XFMR	3B16XHS	3B16	64.30	562.58	566.24	
B10X-B	2W XFMR	B10XBHS	B10	81.92	550.47	556.53	
3XR1	3W Xfmr	SWITCHYARD-3	3XR1-X	2.05	48.67	48.72	
	3W Xfmr	SWITCHYARD-3	3XR1-Y	1.45	37.16	37.19	
	3W Xfmr	3XR1-X	3XR1-Y	234.80	1143.83	1167.68	
0XB1002P1	Cable	B10	BP	193.61	302.86	359.46	
0XB1014P1	Cable	B10	BO	144.93	226.71	269.08	
0XB1015P1	Cable	B10	ZTB45	1956.57	739.31	2091.59	
0XB1015P2	Cable	ZTB45	D645	393.54	47.26	396.37	
3AA0402P1	Cable	3A04	D007-3A0402	1.38	0.90	1.65	
3AA0409P1	Cable	3A04	3D004-3A0409	8.00	5.21	9.54	
3AA0417P1	Cable	3A04	3B04XHS	2.01	1.31	2.40	
3AB0403P1	Cable	3B04	3BRA	56.47	57.45	80.55	
3AB0407P1	Cable	3B04	3BD	1393.46	1417.64	1987.82	
3AB0414P1	Cable	3B04	3BE	56.47	57.45	80.55	
3AB0415P1	Cable	3B04	3BY	34.30	53.65	63.68	
3AB0417P1	Cable	3B04	BQ	329.69	335.42	470.32	
3AB0418P1	Cable	3B04	DB0415-3B0418	502.91	284.20	577.66	
3ABRA06P1	Cable	3BRA	3L707-3BRA06	6124.39	221.27	6128.39	
3XA0304P1	Cable	3A03	3B13XHS	1.90	1.24	2.27	
3XA0309P1	Cable	3A03	ASCI	6.45	4.19	7.69	
3XA0310P1	Cable	3A03	3B12XHS	1.73	1.12	2.06	
3XA0311P1	Cable	3A03	3B03XHS	1.15	0.75	1.37	
3XA0312P1	Cable	3A03	3PEXCCS	5.05	4.39	6.69	
3XA0801P1	Cable	3A08	B10XBHS	4.89	3.18	5.84	
3XA0802P1	Cable	3A08	3B16XHS	1.73	1.12	2.06	
3XA0803P1	Cable	3A08	3B01XHS	5.84	3.80	6.97	
3XA0809P1	Cable	3A08	3B02XHS	6.68	4.34	7.97	
3XB0102P1	Cable	3B01	3BA	61.96	96.92	115.03	
3XB0205P1	Cable	3B02	3BHP02	182.55	125.70	221.64	
3XB0206P1	Cable	3B02	3BHP03	182.55	125.70	221.64	

AUXILIARY SYSTEM VOLTAGE REGULATION

ICCN C - 130

CCN No. \_\_\_\_\_

Project: E4C-090 REV.3 ICCN C - 130

ETAP

Page: 10

Location: SONGS 2 & 3

5.00N

Date: 05-25-2005

Contract:

SN: SCALEDISON

Engineer: W. P. Lennartz

Study Case: 3A14aa

Revision: Base

Filename: E4C090

Config.: 090-3A14aa

ECP 050500255 - 34 ICCN C - 130 UNIT 3 TRAIN A

CKT/Branch		Connected Bus ID		% Impedance, Pos. Seq., 100 MVA Base			
ID	Type	From Bus	To Bus	R	X	Z	Y
3XB0210P1,P2	Cable	3B02	3BHP01	347.63	160.70	382.97	
3XB0306P1	Cable	3B03	3BF	347.39	543.42	644.97	
3XB0314P1	Cable	3B03	3BB	778.75	976.15	1248.73	
3XB0402P1	Cable	3B04	3BHP04	488.17	496.64	696.39	
3XB1202P1	Cable	3B12	3BV	200.25	313.24	371.78	
3XB1203P1	Cable	3B12	3BLX	534.77	670.32	857.50	
3XB1211P1	Cable	3B12	3L111	1102.02	1121.14	1572.07	
3XB1303P1	Cable	3B13	3BMX	268.09	336.05	429.89	
3XB1305P1	Cable	3B13	3BC	539.03	675.66	864.33	
3XB1602P1	Cable	3B16	3BX	247.82	387.66	460.11	
3XB1603P1,P2	Cable	3B16	BT-3B1603	337.89	343.75	482.01	
3XB1611P1	Cable	3B16	3B1611BP	673.96	685.66	961.43	
3XXR169P1-P3	Cable	3XR1-X	3A04	2.30	3.42	4.12	
3XXR169P7,P8	Cable	3XR1-Y	3A08	3.34	4.96	5.98	
3XXR169PA-PD,P9	Cable	3XR1-Y	3A03	0.82	1.22	1.47	
3BD18	Tie Breakr	3BD	3BD18-HTRS				
3BD26	Tie Breakr	3BD	3Q020				
3BDM	Tie Breakr	3BD	3BDMM				
3BDS	Tie Breakr	3BD	3BDSM				
3BE51	Tie Breakr	3BE	3T063				
3BEM	Tie Breakr	3BE	3BEMM				
3BES	Tie Breakr	3BE	3BESM				
3BRA22	Tie Breakr	3BRA	3Q074				
3BRAM	Tie Breakr	3BRA	3BRAMM				
3BRAS	Tie Breakr	3BRA	3BRASM				
3BY39	Tie Breakr	3BY	3BY39-HTRS				
3BY40	Tie Breakr	3BY	3BY40-HTRS				
3BY42	Tie Breakr	3BY	3Q039				
3BYM	Tie Breakr	3BY	3BYMM				
3BYS	Tie Breakr	3BY	3BYSM				
BQ27	Tie Breakr	BQ	Q033				
BQM	Tie Breakr	BQ	BQMM				
BQS	Tie Breakr	BQ	BQSM				
U3-SWYD-CB	Tie Breakr	SWITCHYARD-3	SWITCHYARD				
3D004	Tie Switch	3D004-3P018	3D004-3A0409				
3L707X	Tie Switch	3HV9377-N	3L707-3BRA06				
BT XFRSW	Tie Switch	BT	BT-3B1603				
D007	Tie Switch	D007-E336	D007-3A0402				
DB0415	Tie Switch	DB0415-E418	DB0415-3B0418				

AUXILIARY SYSTEM VOLTAGE REGULATION

ICCN C - 130

CCN No. \_\_\_\_\_

Project: E4C-090 REV.3 ICCN C-130

ETAP

Page: 11

Location: SONGS 2 & 3

5.0.0N

Date: 05-25-2005

Contract:

SN: SCALEDISON

Engineer: W. P. Lennartz

Study Case: 3A14aa

Revision: Base

Filename: E4C090

Config.: 090-3A14aa

ECP 050500255 - 34 ICCN C - 130 UNIT 3 TRAIN A

Equipment Cable Input Data

Equipment Cable ID	Equipment ID	Equipment Type	Ohms or Siemens/1000 ft per Conductor									O/L Heater	
			Library	Size	Length			R	X	Y	Resistance		
					Adj. (ft)	% Tol	#/lb				T (°C)	Adj. (ohm)	% Tol
0ABQ07P1	2A173	Ind. Motor	0.6MCUN3	12	358.0	0.0	1	75	1.97200	.04560	.0000000	.0000	0.0
0ABQ08P1	2E255	Ind. Motor	0.6MCUN3	10	216.0	0.0	1	75	1.24000	.04480	.0000000	.0000	0.0
0ABQ05P1	2L270	Stat. Load	0.6MCUN3	12	410.0	0.0	1	75	1.97200	.04560	.0000000	.0000	0.0
3XB0310P1,P2	3A001	Ind. Motor	0.6MCUN1	1/0	227.0	0.0	1	75	.13100	.04950	.0000000	.0000	0.0
3AB0409P1-P3	3A071	Ind. Motor	0.6MCUN1	1/0	447.0	0.0	1	75	.13100	.04950	.0000000	.0000	0.0
3AB0419P1-P3	3A074	Ind. Motor	0.6MCUN1	1/0	498.0	0.0	1	75	.13100	.04950	.0000000	.0000	0.0
0ABQ14P1	3A173	Ind. Motor	0.6MCUN3	12	368.0	0.0	1	75	1.97200	.04560	.0000000	.0000	0.0
3ABD12P1	3A274	Ind. Motor	0.6MCUN3	2	58.0	0.0	1	75	.19700	.03440	.0000000	.0000	0.0
3ABD13P1	3A275	Ind. Motor	0.6MCUN3	2	122.0	0.0	1	75	.19700	.03440	.0000000	.0000	0.0
3ABY07P1	3A370	Ind. Motor	0.6MCUN3	12	403.0	0.0	1	75	1.97200	.04560	.0000000	.0000	0.0
3ABY08P1	3A373	Ind. Motor	0.6MCUN3	12	520.0	0.0	1	75	1.97200	.04560	.0000000	.0000	0.0
3ABY36P1	3A394	Ind. Motor	0.6MCUN3	10	628.0	0.0	1	75	1.24000	.04480	.0000000	.0000	0.0
3ABY03P1	3B001	Stat. Load	0.6MCUN1	1/0	122.0	0.0	1	75	.13100	.04950	.0000000	.0000	0.0
3ABE04P1	3B003	Stat. Load	0.6MCUN1	1/0	117.0	0.0	1	75	.13100	.04950	.0000000	.0000	0.0
3XB1609P2	3B005	Stat. Load	0.6MCUN1	3/0	191.0	0.0	1	75	.08600	.04860	.0000000	.0000	0.0
3XB0210P3-P5	3E122-H1	Stat. Load	0.6MCUN3	2	284.0	0.0	1	75	.19700	.03440	.0000000	.0000	0.0
3XB0206P2-P4	3E124-H1	Stat. Load	0.6MCUN3	2	290.0	0.0	1	75	.19700	.03440	.0000000	.0000	0.0
3XB0205P2,P3,PE	3E126-H1	Stat. Load	0.6MCUN3	2	282.0	0.0	1	75	.19700	.03440	.0000000	.0000	0.0
3XB0402P2,P3,P4	3E128-H1 [X]	Stat. Load	0.6MCUN3	2	314.0	0.0	1	75	.19700	.03440	.0000000	.0000	0.0
3XA0803P1	3E202	Ind. Motor	0.6MCUN3	250	142.0	0.0	1	75	.05470	.03560	.0000000	.0000	0.0
0ABQ15P1	3E255	Ind. Motor	0.6MCUN3	10	346.0	0.0	1	75	1.24000	.04480	.0000000	.0000	0.0
3ABY38P1	3E370	Ind. Motor	0.6MCUN3	2	450.0	0.0	1	75	.19700	.03440	.0000000	.0000	0.0
3ABY39P6	3E370H	Stat. Load	0.6MCUN3	12	460.0	0.0	1	75	1.97200	.04560	.0000000	.0000	0.0
3XB0209P1-P3	3E394	Ind. Motor	0.6MCUN1	1/0	308.0	0.0	1	75	.13100	.04950	.0000000	.0000	0.0
3XB0106P1-P3	3E397	Ind. Motor	0.6MCUN1	1/0	213.0	0.0	1	75	.13100	.04950	.0000000	.0000	0.0
3AB0410P1-P3	3E399	Ind. Motor	0.6MCUN1	3/0	315.0	0.0	1	75	.08600	.04860	.0000000	.0000	0.0
3ABY40P6,P7,P8	3E399H	Stat. Load	0.6MCUN3	12	442.0	0.0	1	75	1.97200	.04560	.0000000	.0000	0.0
3AB0411P1-P3	3E401	Ind. Motor	0.6MCUN1	3/0	316.0	0.0	1	75	.08600	.04860	.0000000	.0000	0.0
3ABY40P9,PA,PB	3E401H1	Stat. Load	0.6MCUN3	12	366.0	0.0	1	75	1.97200	.04560	.0000000	.0000	0.0
3ABY24P1	3E417	Ind. Motor	0.6MCUN3	10	430.0	0.0	1	75	1.24000	.04480	.0000000	.0000	0.0
3ABY22P1	3E427	Ind. Motor	0.6MCUN3	10	120.0	0.0	1	75	1.24000	.04480	.0000000	.0000	0.0
3ABY20P1	3E437	Ind. Motor	0.6MCUN3	12	370.0	0.0	1	75	1.97200	.04560	.0000000	.0000	0.0
3ABY21P1	3E438	Ind. Motor	0.6MCUN3	12	370.0	0.0	1	75	1.97200	.04560	.0000000	.0000	0.0
3ABY11P1	3E439	Ind. Motor	0.6MCUN3	12	330.0	0.0	1	75	1.97200	.04560	.0000000	.0000	0.0
3ABY12P1	3E440	Ind. Motor	0.6MCUN3	12	330.0	0.0	1	75	1.97200	.04560	.0000000	.0000	0.0
3ABY37P1	3E441	Ind. Motor	0.6MCUN3	12	460.0	0.0	1	75	1.97200	.04560	.0000000	.0000	0.0
3ABY30P1	3E453	Ind. Motor	0.6MCUN3	12	374.0	0.0	1	75	1.97200	.04560	.0000000	.0000	0.0
3ABY31P1	3E454	Ind. Motor	0.6MCUN3	12	309.0	0.0	1	75	1.97200	.04560	.0000000	.0000	0.0
3ABE03P1,P2	3E464	Stat. Load	0.6MCUN3	2	464.0	0.0	1	75	.19700	.03440	.0000000	.0000	0.0
3ABY25P1	3E517	Ind. Motor	0.6MCUN3	12	354.0	0.0	1	75	1.97200	.04560	.0000000	.0000	0.0
3ABD22P1	3E546	Ind. Motor	0.6MCUN3	2	148.0	0.0	1	75	.19700	.03440	.0000000	.0000	0.0
3ABD21P1	3E550	Ind. Motor	0.6MCUN3	2	178.0	0.0	1	75	.19700	.03440	.0000000	.0000	0.0
3ABE49P1,P2	3E652	Stat. Load	0.6MCUN3	12	500.0	0.0	1	75	1.97200	.04560	.0000000	.0000	0.0



AUXILIARY SYSTEM VOLTAGE REGULATION

ICCN C - 130

CCN No. \_\_\_\_\_

Project: E4C-090 REV.3 ICCN C - 130  
 Location: SONGS 2 & 3  
 Contract:  
 Engineer: W. P. Lennartz  
 Filename: E4C090

ETAP  
 5.0.0N

Study Case: 3A14aa

Page: 12  
 Date: 05-25-2005  
 SN: SCALEDISON  
 Revision: Base  
 Config.: 090-3A14aa

ECP 050500255 - 34 ICCN C - 130 UNIT 3 TRAIN A

Equipment Cable		Equipment		Ohms or Siemens/1000 ft per Conductor									O/L Heater	
ID	ID	Type	Library	Size	Length				T (°C)	R	X	Y	Resistance	
					Adj. (ft)	% Tol	#/ph						Adj. (ohm)	% Tol
3ABE36P1	3HV4731	Ind. Motor	0.6MCUN3	12	562.0	0.0	1	75	1.97200	.04560	.0000000	.0000	0.0	
3XBI606P1,P2	3L046	Ind. Motor	0.6MCUN1	250	416.0	0.0	2	75	.06080	.04800	.0000000	.0000	0.0	
3ABE42P1	3L256	Stat. Load	0.6MCUN3	6	360.0	0.0	1	75	.49300	.03910	.0000000	.0000	0.0	
0ABQ05P1	3L270	Stat. Load	0.6MCUN3	12	650.0	0.0	1	75	1.97200	.04560	.0000000	.0000	0.0	
3XBY23P1	3L411(X)	Stat. Load	0.6MCUN3	12	177.0	0.0	1	75	1.97200	.04560	.0000000	.0000	0.0	
3ABY34P1	3P009	Ind. Motor	0.6MCUN3	2	470.0	0.0	1	75	.19700	.03440	.0000000	.0000	0.0	
3AA0403P1	3P012	Ind. Motor	8.0MCUN3	250	332.0	0.0	1	75	.05470	.03560	.0000000	.0000	0.0	
3ABY40P1	3P012H	Stat. Load	0.6MCUN3	12	372.0	0.0	1	75	1.97200	.04560	.0000000	.0000	0.0	
3AA0407P1	3P015	Ind. Motor	8.0MCUN3	250	338.0	0.0	1	75	.05470	.03560	.0000000	.0000	0.0	
3ABY39P1	3P015H	Stat. Load	0.6MCUN3	12	369.0	0.0	1	75	1.97200	.04560	.0000000	.0000	0.0	
3AA0408P1	3P017	Ind. Motor	8.0MCUN3	250	364.0	0.0	1	75	.05470	.03560	.0000000	.0000	0.0	
3ABY39P2	3P017H	Stat. Load	0.6MCUN3	12	548.0	0.0	1	75	1.97200	.04560	.0000000	.0000	0.0	
3WAD004P1	3P018	Ind. Motor	8.0MCUN3	250	36.0	0.0	1	75	.05470	.03560	.0000000	.0000	0.0	
3ABY39P3	3P018HA	Stat. Load	0.6MCUN3	12	400.0	0.0	1	75	1.97200	.04560	.0000000	.0000	0.0	
3AA0405P1	3P024	Ind. Motor	8.0MCUN3	250	328.0	0.0	1	75	.05470	.03560	.0000000	.0000	0.0	
3XA0308P1	3P030	Ind. Motor	8.0MCUN3	750	73.0	0.0	1	75	.02080	.03090	.0000000	.0000	0.0	
3XA0307P1	3P031	Ind. Motor	8.0MCUN3	750	107.0	0.0	1	75	.02080	.03090	.0000000	.0000	0.0	
3XAC312P2	3P058	Ind. Motor	5.0MCUS1	350	36.0	0.0	1	75	.04610	.05140	.0000000	.0000	0.0	
3XB0303P1	3P075	Ind. Motor	0.6MCUN1	10	166.0	0.0	1	75	.13100	.04950	.0000000	.0000	0.0	
3ABD23P1	3P093	Ind. Motor	0.6MCUN3	12	170.0	0.0	1	75	1.97200	.04560	.0000000	.0000	0.0	
3ABD24P1	3P096	Ind. Motor	0.6MCUN3	12	170.0	0.0	1	75	1.97200	.04560	.0000000	.0000	0.0	
3ABY10P1	3P1018	Ind. Motor	0.6MCUN3	10	370.0	0.0	1	75	1.24000	.04480	.0000000	.0000	0.0	
3ABY39P9	3P1018H	Stat. Load	0.6MCUN3	12	370.0	0.0	1	75	1.97200	.04560	.0000000	.0000	0.0	
3ABY39P4	3P112H	Stat. Load	0.6MCUN3	12	482.0	0.0	1	75	1.97200	.04560	.0000000	.0000	0.0	
3XA0306P1	3P115	Ind. Motor	8.0MCUN3	500	308.0	0.0	1	75	.02920	.03340	.0000000	.0000	0.0	
3XA0305P1	3P117	Ind. Motor	8.0MCUN3	500	340.0	0.0	1	75	.02920	.03340	.0000000	.0000	0.0	
3XA0313P1	3P120	Ind. Motor	8.0MCUN3	250	678.0	0.0	1	75	.05470	.03560	.0000000	.0000	0.0	
3XB1206P1-P3	3P127	Ind. Motor	0.6MCUN1	500	563.0	0.0	1	75	.03590	.04500	.0000000	.0000	0.0	
3XB0110P1	3P128	Ind. Motor	0.6MCUN1	20	314.0	0.0	1	75	.10600	.04900	.0000000	.0000	0.0	
3XB1306P1	3P135	Ind. Motor	0.6MCUN1	40	701.0	0.0	1	75	.07000	.04820	.0000000	.0000	0.0	
3AA0404P1	3P141	Ind. Motor	8.0MCUN3	250	540.0	0.0	1	75	.05470	.03560	.0000000	.0000	0.0	
3ABY39P8	3P141H	Stat. Load	0.6MCUN3	12	779.0	0.0	1	75	1.97200	.04560	.0000000	.0000	0.0	
3ABY14P1	3P174	Ind. Motor	0.6MCUN3	6	330.0	0.0	1	75	.49300	.03910	.0000000	.0000	0.0	
3ABY40P2	3P174H	Stat. Load	0.6MCUN3	12	420.0	0.0	1	75	1.97200	.04560	.0000000	.0000	0.0	
3ABY15P1	3P175	Ind. Motor	0.6MCUN3	6	330.0	0.0	1	75	.49300	.03910	.0000000	.0000	0.0	
3ABY40P3	3P175H	Stat. Load	0.6MCUN3	12	300.0	0.0	1	75	1.97200	.04560	.0000000	.0000	0.0	
3AB0413P1	3P190	Ind. Motor	0.6MCUN1	30	316.0	0.0	1	75	.08500	.04860	.0000000	.0000	0.0	
3ABY40P4	3P190H	Stat. Load	0.6MCUN3	12	420.0	0.0	1	75	1.97200	.04560	.0000000	.0000	0.0	
3ABY40P5	3P191HA	Stat. Load	0.6MCUN3	12	336.0	0.0	1	75	1.97200	.04560	.0000000	.0000	0.0	
3XB0309P1	3P290	Ind. Motor	0.6MCUN1	10	198.0	0.0	1	75	.13100	.04950	.0000000	.0000	0.0	
3AA0411P1	3P307	Ind. Motor	8.0MCUN3	250	430.0	0.0	1	75	.05470	.03560	.0000000	.0000	0.0	
3ABY39P5	3P307H	Stat. Load	0.6MCUN3	12	466.0	0.0	1	75	1.97200	.04560	.0000000	.0000	0.0	
3ABD10P1	3P996/3P1015	Ind. Motor	0.6MCUN3	12	106.0	0.0	1	75	1.97200	.04560	.0000000	.0000	0.0	
3ABD11P1	3P997/3P1014	Ind. Motor	0.6MCUN3	12	60.0	0.0	1	75	1.97200	.04560	.0000000	.0000	0.0	
3ABE41P1	3RU7804-1	Stat. Load	0.6MCUN3	12	230.0	0.0	1	75	1.97200	.04560	.0000000	.0000	0.0	
3ABE02P1	3RU7822-1	Stat. Load	0.6MCUN3	12	500.0	0.0	1	75	1.97200	.04560	.0000000	.0000	0.0	
3XB1210P1	3T011	Stat. Load	0.6MCUN1	350	294.0	0.0	1	75	.04610	.04690	.0000000	.0000	0.0	

AUXILIARY SYSTEM VOLTAGE REGULATION

ICCN C - 130

CCN No. \_\_\_\_\_

Project: E4C-090 REV.3 ICCN C-130  
 Location: SONGS 2 & 3  
 Contract:  
 Engineer: W. P. Lennartz  
 Filename: E4C090

ETAP  
 5.0.0N

Study Case: 3A14aa

Page: 13  
 Date: 05-25-2005  
 SN: SCALEDISON  
 Revision: Base  
 Config.: 090-3A14aa

ECP 050500255 - 34 ICCN C-130 UNIT 3 TRAIN A

Equipment Cable		Equipment		Ohms or Siemens/1000 ft per Conductor									O/L Heater	
ID	ID	Type	Library	Size	Length			T (°C)	R	X	Y	Resistance		
					Adj. (ft)	% Tol	#/ph					Adj. (ohm)	% Tol	
3XA0412P1	3T014[X]	Stat. Load	8.0MCUN3	250	462.0	0.0	1	75	.05470	.03560	.0000000	.0000	0.0	
3XBY33P2,P3	3T110/3Q071[X]	Stat. Load	0.6MCUN1	2	949.0	0.0	1	75	.20300	.05130	.0000000	.0000	0.0	
0ABQ22P1	A053	Ind. Motor	0.6MCUN3	12	472.0	0.0	1	75	1.97200	.04560	.0000000	.0000	0.0	
0ABQ23P1	A056	Ind. Motor	0.6MCUN3	12	472.0	0.0	1	75	1.97200	.04560	.0000000	.0000	0.0	
0ABQ09P2	A207	Ind. Motor	0.6MCUN3	10	640.0	0.0	1	75	1.24000	.04480	.0000000	.0000	0.0	
0XAC101P2	C443	Ind. Motor	8.0MCUN1	250	90.0	0.0	1	75	.06090	.05250	.0000000	.0000	0.0	
0ABQ04P1,P2	E297	Stat. Load	0.6MCUN3	12	518.0	0.0	1	75	1.97200	.04560	.0000000	.0000	0.0	
0AAD007P1	E336	Ind. Motor	8.0MCUN3	250	216.0	0.0	1	75	.05470	.03560	.0000000	.0000	0.0	
0ABD415P1	E418	Ind. Motor	0.6MCUN1	3/0	415.0	0.0	1	75	.08600	.04860	.0000000	.0000	0.0	
0XB1011P1	E643	Stat. Load	0.6MCUN1	500	188.0	0.0	1	75	.03590	.04500	.0000000	.0000	0.0	
0XB1015P3	E645	Stat. Load	0.6MCUN3	10	10.0	0.0	1	75	1.24000	.04480	.0000000	.0000	0.0	
0ABQ13P1	L211-1	Stat. Load	0.6MCUN3	6	90.0	0.0	1	75	.49300	.03910	.0000000	.0000	0.0	
0ABQ26P1	L211-4	Stat. Load	0.6MCUN3	6	120.0	0.0	1	75	.49300	.03910	.0000000	.0000	0.0	
0XBQ11P1	L437[X]	Stat. Load	0.6MCUN3	10	300.0	0.0	1	75	1.24000	.04480	.0000000	.0000	0.0	
3XBY19P1	LP35A[X]	Stat. Load	0.6MCUN3	6	339.0	0.0	1	75	.49300	.03910	.0000000	.0000	0.0	
3XB1307P1	N002	Stat. Load	0.6MCUN1	1/0	824.0	0.0	1	75	.13100	.04950	.0000000	.0000	0.0	
CXB1006P1	P159	Ind. Motor	0.6MCUN1	1/0	402.0	0.0	1	75	.13100	.04950	.0000000	.0000	0.0	
0ABQ24P1	P162	Ind. Motor	0.6MCUN3	2	468.0	0.0	1	75	.19700	.03440	.0000000	.0000	0.0	
0ABQ20P1	P445	Ind. Motor	0.6MCUN3	12	584.0	0.0	1	75	1.97200	.04560	.0000000	.0000	0.0	
0ABQ25P1	W310	Ind. Motor	0.6MCUN3	12	584.0	0.0	1	75	1.97200	.04560	.0000000	.0000	0.0	



AUXILIARY SYSTEM VOLTAGE REGULATION

ICCN C - 130

CCN No. \_\_\_\_\_

Project: E4C-090 REV.3 ICCN C - 130  
 Location: SONGS 2 & 3  
 Contract:  
 Engineer: W. P. Lennartz  
 Filename: E4C090

ETAP  
 5.0.0N

Study Case: 3A14aa

Page: 15  
 Date: 05-25-2005  
 SN: SCALEDISON  
 Revision: Base  
 Config.: 090-3A14aa

ECP 050500255 - 34 ICCN C - 130 UNIT 3 TRAIN A

Bus		Voltage		Generation		Load		Load Flow				XFMR	
ID	kV	kV	Ang.	MW	Mvar	MW	Mvar	ID	MW	Mvar	Amp	% PF	% Tap
								3BHP04	0.186	0.002	236.4	100.0	
								3B04XHS	-1.179	-0.631	1698.0	88.2	
3B04XHS	4.160	4.189	-1.6	0	0	0	0	3A04	-1.199	-0.763	195.9	84.4	
								3B04	1.199	0.763	195.9	84.4	
3B12	0.480	0.450	-7.7	0	0	0.325	0.159	3BV	0.205	0.126	308.8	85.3	
								3BLX	0.052	0.027	75.2	88.5	
								3L111	0.180	0.073	250.1	92.6	
								3B12XHS	-0.762	-0.386	1097.0	89.2	
3B12XHS	4.160	4.069	-4.0	0	0	0	0	3A03	-0.768	-0.453	126.6	86.1	
								3B12	0.768	0.453	126.6	86.1	
3B13	0.480	0.461	-5.9	0	0	0.227	0.080	3BMX	0.052	0.026	72.4	89.2	
								3BC	0.108	0.064	157.1	86.0	
								3B13XHS	-0.386	-0.170	528.5	91.5	
3B13XHS	4.160	4.069	-4.0	0	0	0	0	3A03	-0.388	-0.186	61.0	90.2	
								3B13	0.388	0.186	61.0	90.2	
3B16	0.480	0.447	-7.6	0	0	0.162	0.111	3BX	0.309	0.145	441.7	90.6	
								BT-3B1603	0.379	0.212	561.2	87.2	
								3B1611BP	0.127	0.110	217.7	75.5	
								3B16XHS	-0.977	-0.579	1467.8	86.0	
3B16XHS	4.160	4.069	-4.0	0	0	0	0	3A08	-0.987	-0.671	169.4	82.7	
								3B16	0.987	0.671	169.4	82.7	
3B1611BP	0.480	0.437	-7.7	0	0	0.125	0.108	3B16	-0.125	-0.108	217.7	75.6	
3BA	0.480	0.448	-5.6	0	0	0.265	0.140	3B01	-0.265	-0.140	386.9	88.4	
3BB	0.480	0.441	-7.5	0	0	0.158	0.091	3B03	-0.158	-0.091	238.2	86.5	
3BC	0.480	0.455	-6.1	0	0	0.107	0.063	3B13	-0.107	-0.063	157.1	86.3	
3BD	0.480	0.435	-6.4	0	0	0.130	0.088	3B04	-0.142	-0.096	226.9	82.8	
								3BD18-HTRS	0.000	0.000	0.0	0.0	
								3Q020	0.003	0.002	5.5	85.0	
								3BDMM	0.005	0.003	7.3	83.0	
								3BDMM	0.003	0.002	5.5	85.0	
3BD18-HTRS	0.480	0.435	-6.4	0	0	0	0	3BD	0.000	0.000	0.0	0.0	
3BDMM	0.460	0.435	-6.4	0	0	0.005	0.003	3BD	-0.005	-0.003	7.3	83.0	
3BDMM	0.480	0.435	-6.4	0	0	0.003	0.002	3BD	-0.003	-0.002	5.5	85.0	
3BE	0.480	0.454	-5.9	0	0	0.076	0.039	3B04	-0.104	-0.056	150.1	87.9	
								3T063	0.019	0.012	28.5	85.0	
								3BEMM	0.005	0.003	7.0	83.0	
								3BESM	0.004	0.002	5.7	85.0	
3BEMM	0.460	0.454	-5.9	0	0	0.005	0.003	3BE	-0.005	-0.003	7.0	83.0	

AUXILIARY SYSTEM VOLTAGE REGULATION

ICCN C - 130

CCN No. \_\_\_\_\_

Project: E4C-090 REV.3 ICCN C-130

ETAP

Page: 16

Location: SONGS 2 & 3

5.0.0N

Date: 05-25-2005

Contract:

SN: SCALEDISON

Engineer: W. P. Lemartz

Study Case: 3A14aa

Revision: Base

Filename: E4C090

Config: 090-3A14aa

ECP 050500255 - 34 ICCN C-130 UNIT 3 TRAIN A

Bus		Voltage			Generation		Load		Load Flow				XFMR	
ID	kV	kV	Ang.	MW	Mvar	MW	Mvar	ID	MW	Mvar	Amp	% PF	% Tap	
3BESM	0.480	0.454	-5.9	0	0	0.004	0.002	3BE	-0.004	-0.002	5.7	85.0		
3BF	0.480	0.445	-7.6	0	0	0.238	0.103	3B03	-0.238	-0.103	336.8	91.7		
3BIIP01	0.480	0.460	-7.0	0	0	0.144	0.000	3B02	-0.144	0.000	181.0	100.0		
3BHPO2	0.480	0.461	-7.0	0	0	0.194	0.000	3B02	-0.194	0.000	242.6	100.0		
3BIIP03	0.480	0.461	-7.0	0	0	0.194	0.000	3B02	-0.154	0.000	242.6	100.0		
3BHPO4	0.480	0.450	-6.6	0	0	0.184	0.000	3B04	-0.184	0.000	236.4	100.0		
3BLX	0.480	0.447	-7.9	0	0	0.052	0.027	3B12	-0.052	-0.027	75.2	88.6		
3BMX	0.480	0.460	-5.9	0	0	0.051	0.026	3B13	-0.051	-0.026	72.4	89.2		
3BRA	0.480	0.455	-5.9	0	0	0	0	3B04	-0.014	-0.009	20.6	84.9		
								3L707-3BRA06	0.002	0.001	2.3	90.0		
								3Q074	0.004	0.002	5.7	85.0		
								3BRAMM	0.005	0.003	7.0	83.0		
								3BRASM	0.004	0.002	5.7	85.0		
3BRAMM	0.460	0.455	-5.9	0	0	0.005	0.003	3BRA	-0.005	-0.003	7.0	83.0		
3BRASM	0.480	0.455	-5.9	0	0	0.004	0.002	3BRA	-0.004	-0.002	5.7	85.0		
3BV	0.480	0.445	-8.0	0	0	0.204	0.123	3B12	-0.204	-0.123	308.8	85.5		
3BX	0.480	0.439	-8.2	0	0	0.306	0.139	3B16	-0.306	-0.139	441.7	91.0		
3BY	0.480	0.454	-6.0	0	0	0.193	0.125	3B04	-0.226	-0.140	338.3	85.1		
								3BY39-HTRS	0.007	0.000	8.9	100.0		
								3BY40-HTRS	0.003	0.000	3.4	100.0		
								3Q039	0.015	0.009	22.7	85.0		
								3BYMM	0.005	0.003	7.0	83.0		
								3BYSM	0.004	0.002	5.7	85.0		
3BY39-HTRS	0.480	0.454	-6.0	0	0	0.007	0.000	3BY	-0.007	0.000	8.9	100.0		
3BY40-HTRS	0.480	0.454	-6.0	0	0	0.003	0.000	3BY	-0.003	0.000	3.4	100.0		
3BYMM	0.460	0.454	-6.0	0	0	0.005	0.003	3BY	-0.005	-0.003	7.0	83.0		
3BYSM	0.480	0.454	-6.0	0	0	0.004	0.002	3BY	-0.004	-0.002	5.7	85.0		
3D004-3A0409	4.160	4.188	-1.6	0	0	0	0	3A04	-0.408	-0.174	61.1	92.0		
								3D004-3P018	0.408	0.174	61.1	92.0		
3D004-3P018	4.160	4.188	-1.6	0	0	0.408	0.174	3D004-3A0409	-0.408	-0.174	61.1	92.0		
3HV9377-N	0.480	0.454	-5.9	0	0	0.002	0.001	3L707-3BRA06	-0.002	-0.001	2.3	90.0		
3L111	0.480	0.434	-8.6	0	0	0.175	0.068	3B12	-0.175	-0.068	250.1	93.2		
3L707-3BRA06	0.480	0.454	-5.9	0	0	0	0	3BRA	-0.002	-0.001	2.3	90.0		
								3HV9377-N	0.002	0.001	2.3	90.0		
3PEXCCS	4.160	4.064	-4.0	0	0	1.770	0.907	3A03	-1.770	-0.907	282.6	89.0		
3Q020	0.480	0.435	-6.4	0	0	0.003	0.002	3B0	-0.003	-0.002	5.5	85.0		
3Q039	0.480	0.454	-6.0	0	0	0.015	0.009	3BY	-0.015	-0.009	22.7	85.0		
3Q074	0.480	0.455	-5.9	0	0	0.004	0.002	3BRA	-0.004	-0.002	5.7	85.0		

AUXILIARY SYSTEM VOLTAGE REGULATION

ICCN C - 130

CCN No. \_\_\_\_\_

Project: E4C-090 REV.3 ICCN C-130

ETAP

Page: 17

Location: SONGS 2 & 3

5.00N

Date: 05-25-2005

Contract:

SN: SCALEDISON

Engineer: W. P. Lennartz

Study Case: 3A14aa

Revision: Base

Filename: E4C090

Config.: 090-3A14aa

ECP 050500255 - 34 ICCN C-130 UNIT 3 TRAIN A

Bus	Voltage			Generation		Load		ID	Load Flow			XFMR	
	ID	kV	Ang.	MW	Mvar	MW	Mvar		MW	Mvar	Amp	% PF	% Tap
3T063	0.480	0.454	-5.9	0	0	0.019	0.012	3BE	-0.019	-0.012	28.5	85.0	
3XR1-X	4.160	4.199	-1.5	0	0	0	0	3A04	4.796	2.578	748.6	88.1	
								3XR1-Y	-4.796	-2.578	748.6	88.1	
								& SWITCHYARD-3					
3XR1-Y	4.160	4.080	-4.0	0	0	0	0	3A08	3.492	1.573	542.1	91.2	
								3A03	13.797	7.930	2252.2	86.7	
								SWITCHYARD-3	-17.290	-9.503	2792.2	87.6	
								& 3XR1-X					
ASC1	4.160	4.069	-4.0	0	0	0.232	0.115	3A03	-0.232	-0.115	36.8	89.5	
B10	0.480	0.459	-6.5	0	0	0.145	0.041	BP	0.276	0.147	394.0	88.2	
								BO	0.280	0.035	355.3	99.2	
								ZTB45	0.008	0.000	10.3	100.0	
								B10XBHS	-0.710	-0.223	935.9	95.4	
B10XBHS	4.160	4.068	-4.0	0	0	0	0	3A08	-0.715	-0.259	108.0	94.0	
								B10	0.715	0.259	108.0	94.0	
BO	0.480	0.456	-7.0	0	0	0.279	0.033	B10	-0.279	-0.033	355.3	99.3	
BP	0.480	0.454	-6.9	0	0	0.274	0.144	B10	-0.274	-0.144	394.0	88.5	
BQ	0.480	0.451	-6.0	0	0	0.108	0.065	3B04	-0.128	-0.077	190.9	85.6	
								Q033	0.011	0.007	16.9	85.0	
								BQMM	0.005	0.003	7.0	83.0	
								BQSM	0.004	0.002	5.6	85.0	
BQMM	0.460	0.451	-6.0	0	0	0.005	0.003	BQ	-0.005	-0.003	7.0	83.0	
BQSM	0.480	0.451	-6.0	0	0	0.004	0.002	BQ	-0.004	-0.002	5.6	85.0	
BT	0.480	0.435	-8.0	0	0	0.370	0.204	BT-3B1603	-0.370	-0.204	561.2	87.6	
BT-3B1603	0.480	0.435	-8.0	0	0	0	0	3B16	-0.370	-0.204	561.2	87.6	
								BT	0.370	0.204	561.2	87.6	
D007-3A0402	4.160	4.190	-1.6	0	0	0	0	3A04	-0.456	-0.256	72.0	87.2	
								D007-E336	0.456	0.256	72.0	87.2	
D007-E336	4.160	4.190	-1.6	0	0	0.456	0.256	D007-3A0402	-0.456	-0.256	72.0	87.2	
D645	0.480	0.458	-6.6	0	0	0.008	0.000	ZTB45	-0.008	0.000	10.3	100.0	
DB0415-3B0418	0.480	0.450	-5.9	0	0	0	0	3B04	-0.111	-0.071	169.0	84.1	
								DB0415-E418	0.111	0.071	169.0	84.1	
DB0415-E418	0.480	0.450	-5.9	0	0	0.111	0.071	DB0415-3B0418	-0.111	-0.071	169.0	84.1	
Q033	0.480	0.451	-6.0	0	0	0.011	0.007	BQ	-0.011	-0.007	16.9	85.0	
* SWITCHYARD	230.000	219.500	0.0	22.161	13.913	0	0	SWITCHYARD-3	22.161	13.913	68.8	84.7	
SWITCHYARD-3	230.000	219.500	0.0	0	0	0	0	SWITCHYARD	-22.161	-13.913	68.8	84.7	
								3XR1-X	22.161	13.913	68.8	84.7	-2.500
								& 3XR1-Y					

AUXILIARY SYSTEM VOLTAGE REGULATION

ICCN C - 130

CCN No. \_\_\_\_\_

Project: E4C-090 REV.3 ICCN C-130

ETAP

Page: 18

Location: SONGS 2 & 3

5.0.0N

Date: 05-25-2005

Contract:

SN: SCALEDISON

Engineer: W. P. Lennartz

Study Case: 3A14aa

Revision: Base

Filename: E4C090

Config.: 090-3A14aa

ECP 050500255 - 34 ICCN C - 130 UNIT 3 TRAIN A

Bus		Voltage			Generation		Load		Load Flow				XFMR	
ID	kV	kV	Ang.	MW	Mvar	MW	Mvar	ID	MW	Mvar	Amp	% PF	% Tap	
ZTB45	0.480	0.458	-6.6	0	0	0	0	B10	-0.008	0.000	10.3	100.0		
								D645	0.008	0.000	10.3	100.0		

\* Indicates a voltage regulated bus (voltage controlled or swing type machine connected to it)

# Indicates a bus with a load mismatch of more than 0.1 MVA

AUXILIARY SYSTEM VOLTAGE REGULATION

ICCN C - 130

CCN No. \_\_\_\_\_

Project: E4C-090 REV.3 ICCN C-130

ETAP

Page: 19

Location: SONGS 2 & 3

5.0.0N

Date: 05-25-2005

Contract:

SN: SCALEDISON

Engineer: W. P. Lennartz

Study Case: 3A14aa

Revision: Base

Filename: E4C090

Config.: 090-3A14aa

ECP 050500255 - 34 ICCN C-130 UNIT 3 TRAIN A

Bus Loading Summary Report

Bus ID	kV	Rated Amp	Directly Connected Load								Total Bus Load			Percent Loading
			Constant kVA		Constant Z		Constant I		Generic		MVA	% PF	Amp	
			MW	Mvar	MW	Mvar	MW	Mvar	MW	Mvar				
2G002-BUS	4.160		0	0	0	0	0	0	0	0	0	0.0	0.0	
2G003-BUS	4.160		0	0	0	0	0	0	0	0	0	0.0	0.0	
3G002-BUS	4.160		0	0	0	0	0	0	0	0	0	0.0	0.0	
3G003-BUS	4.160		0	0	0	0	0	0	0	0	0	0.0	0.0	
3A03	4.160	3000.0	10.000	5.865	0.0	0.0	0.0	0.0	0.0	0.0	15.875	86.8	2252.2	75.1
3A04	4.160	3000.0	2.596	1.294	0.129	0.080	0	0	0	0	5.433	88.1	748.6	25.0
3A08	4.160	1200.0	0.796	0.339	0	0	0	0	0	0	3.822	91.2	542.1	45.2
3B01	0.480	2000.0	0.131	0.078	0	0	0	0	0	0	0.453	87.5	581.8	29.1
3B01XHS	4.160		0	0	0	0	0	0	0	0	0.462	86.3	65.5	
3B02	0.480	1600.0	0.049	0.031	0	0	0	0	0	0	0.584	99.8	728.1	45.5
3B02XHS	4.160		0	0	0	0	0	0	0	0	0.592	99.4	84.0	
3B03	0.480	1600.0	0.206	0.120	0	0	0	0	0	0	0.689	88.3	877.3	54.8
3B03XHS	4.160		0	0	0	0	0	0	0	0	0.713	85.8	101.2	
3B04	0.480	2000.0	0.261	0.172	0	0	0	0	0	0	1.337	88.2	1698.0	84.9
3B04XHS	4.160		0	0	0	0	0	0	0	0	1.421	84.4	195.9	
3B12	0.480	1600.0	0.202	0.118	0.123	0.041	0	0	0	0	0.854	89.2	1097.0	68.6
3B12XHS	4.160		0	0	0	0	0	0	0	0	0.892	86.1	126.6	
3B13	0.480	1600.0	0.151	0.079	0.075	0.001	0	0	0	0	0.422	91.5	528.5	33.0
3B13XHS	4.160		0	0	0	0	0	0	0	0	0.430	90.2	61.0	
3B16	0.480	2000.0	0.089	0.043	0.073	0.068	0	0	0	0	1.135	86.0	1467.8	73.4
3B16XHS	4.160		0	0	0	0	0	0	0	0	1.194	82.7	169.4	
3B1611BP	0.480	800.0	0.006	0.004	0.119	0.104	0	0	0	0	0.165	75.6	217.7	27.2
3BA	0.480	600.0	0.153	0.097	0.112	0.043	0	0	0	0	0.300	88.4	386.9	64.5
3BB	0.480	600.0	0.138	0.087	0.020	0.005	0	0	0	0	0.182	86.5	238.2	39.7
3BC	0.480	600.0	0.041	0.030	0.066	0.033	0	0	0	0	0.124	86.3	157.1	26.2
3BD	0.480	600.0	0.130	0.088	0	0	0	0	0	0	0.171	82.8	226.9	37.8
3BD18-INTRS	0.480		0	0	0	0	0	0	0	0	0	0.0	0.0	
3BDMM	0.460		0.005	0.003	0	0	0	0	0	0	0.006	83.0	7.3	
3BDSM	0.480		0	0	0.003	0.002	0	0	0	0	0.004	85.0	5.5	
3BE	0.480	600.0	0.001	0.001	0.075	0.038	0	0	0	0	0.118	87.9	150.1	25.0
3BEMM	0.460		0.005	0.003	0	0	0	0	0	0	0.006	83.0	7.0	
3BESM	0.480		0	0	0.004	0.002	0	0	0	0	0.004	85.0	5.7	
3BF	0.480	600.0	0.104	0.052	0.134	0.051	0	0	0	0	0.260	91.7	336.8	56.1
3BHP01	0.480		0	0	0.144	0	0	0	0	0	0.144	100.0	181.0	
3BHP02	0.480		0	0	0.194	0	0	0	0	0	0.194	100.0	242.6	
3BHP03	0.480		0	0	0.194	0	0	0	0	0	0.194	100.0	242.6	



AUXILIARY SYSTEM VOLTAGE REGULATION

ICCN C - 130

CCN No. \_\_\_\_\_

Project: E4C-090 REV.3 ICCN C-130

ETAP

Page: 20

Location: SONGS 2 & 3

5.0.0N

Date: 05-25-2005

Contract:

SN: SCALEDISON

Engineer: W. P. Lennartz

Study Case: 3A14aa

Revision: Base

Filename: E4C090

Config.: 090-3A14aa

ECP 050500255 - 34 ICCN C-130 UNIT 3 TRAIN A

Bus	ID	kV	Rated Amp	Directly Connected Load								Total Bus Load			
				Constant kVA		Constant Z		Constant I		Generic		MVA	% PF	Amp	Percent Loading
				MW	Mvar	MW	Mvar	MW	Mvar	MW	Mvar				
3BHP04		0.480		0	0	0.184	0	0	0	0	0	0.184	100.0	236.4	
3BLX		0.480	600.0	0.036	0.023	0.015	0.004	0	0	0	0	0.058	88.6	75.2	12.5
3BMX		0.480	600.0	0.035	0.022	0.016	0.004	0	0	0	0	0.058	89.2	72.4	12.1
3BRA		0.480	600.0	0	0	0	0	0	0	0	0	0.016	84.9	20.6	3.4
3BRAMM		0.460		0.005	0.003	0	0	0	0	0	0	0.006	83.0	7.0	
3BRASM		0.480		0	0	0.004	0.002	0	0	0	0	0.004	85.0	5.7	
3BV		0.480	600.0	0.101	0.073	0.102	0.051	0	0	0	0	0.238	85.5	308.8	51.5
3BX		0.480	600.0	0.107	0.070	0.199	0.069	0	0	0	0	0.336	91.0	441.7	73.6
3BY		0.480	600.0	0.139	0.082	0.054	0.043	0	0	0	0	0.266	85.1	338.3	56.4
3BY39-HTRS		0.480		0	0	0.007	0	0	0	0	0	0.007	100.0	8.9	
3BY40-HTRS		0.480		0	0	0.003	0	0	0	0	0	0.003	100.0	3.4	
3BYMM		0.460		0.005	0.003	0	0	0	0	0	0	0.006	83.0	7.0	
3BYSM		0.480		0	0	0.004	0.002	0	0	0	0	0.004	85.0	5.7	
3D004-3A0409		4.160		0	0	0	0	0	0	0	0	0.443	92.0	61.1	
3D004-3P018		4.160		0.408	0.174	0	0	0	0	0	0	0.443	92.0	61.1	
3HV9377-N		0.480		0	0	0.002	0.001	0	0	0	0	0.002	90.0	2.3	
3L111		0.480		0.125	0.049	0.050	0.020	0	0	0	0	0.188	93.2	250.1	
3L707-3BRA06		0.480		0	0	0	0	0	0	0	0	0.002	90.0	2.3	
3PEXCC5		4.160		1.770	0.907	0	0	0	0	0	0	1.989	89.0	282.6	
3Q020		0.480		0	0	0.003	0.002	0	0	0	0	0.004	85.0	5.5	
3Q039		0.480		0	0	0.015	0.009	0	0	0	0	0.018	85.0	22.7	
3Q074		0.480		0	0	0.004	0.002	0	0	0	0	0.004	85.0	5.7	
3T063		0.480		0	0	0.019	0.012	0	0	0	0	0.022	85.0	28.5	
3XR1-X		4.160		0	0	0	0	0	0	0	0	5.445	88.1	748.6	
3XR1-Y		4.160		0	0	0	0	0	0	0	0	19.729	87.6	2792.2	
ASC1		4.160	400.0	0.232	0.115	0	0	0	0	0	0	0.259	89.5	36.8	9.2
B10		0.480	2000.0	0.063	0.040	0.082	0	0	0	0	0	0.744	95.4	935.9	46.8
B10XBHS		4.160		0	0	0	0	0	0	0	0	0.761	94.0	108.0	
BO		0.480	600.0	0.021	0.014	0.258	0.018	0	0	0	0	0.281	99.3	355.3	59.2
BP		0.480	600.0	0.163	0.108	0.111	0.036	0	0	0	0	0.310	88.5	394.0	65.7
BQ		0.480	600.0	0.061	0.038	0.047	0.026	0	0	0	0	0.149	85.6	190.9	31.8
BQMM		0.460		0.005	0.003	0	0	0	0	0	0	0.006	83.0	7.0	
BQSM		0.480		0	0	0.004	0.002	0	0	0	0	0.004	85.0	5.6	
BT		0.480	600.0	0.168	0.100	0.202	0.105	0	0	0	0	0.423	87.6	561.2	93.5
BT-3B1603		0.480		0	0	0	0	0	0	0	0	0.423	87.6	561.2	
D007-3A0402		4.160		0	0	0	0	0	0	0	0	0.523	87.2	72.0	
D007-E336		4.160		0.456	0.256	0	0	0	0	0	0	0.523	87.2	72.0	
D645		0.480		0	0	0.008	0	0	0	0	0	0.008	100.0	10.3	

AUXILIARY SYSTEM VOLTAGE REGULATION

ICCN C - 130

CCN No. \_\_\_\_\_

Project: E4C-090 REV.3 ICCN C - 130  
 Location: SONGS 2 & 3  
 Contract:  
 Engineer: W. P. Lennartz  
 Filename: E4C090

ETAP  
 5.0.0N

Study Case: 3A14aa

Page: 21  
 Date: 05-25-2005  
 SN: SCALEDISON  
 Revision: Base  
 Config.: 090-3A14aa

ECP 050500255-34 ICCN C-130 UNIT 3 TRAIN A

Bus			Directly Connected Load								Total Bus Load			Percent Loading
			Constant kVA		Constant Z		Constant I		Generic		MVA	% PF	Amp	
ID	kV	Rated Amp	MW	Mvar	MW	Mvar	MW	Mvar	MW	Mvar				
DB0415-3B0418	0.480		0	0	0	0	0	0	0	0	0.132	84.1	169.0	
DB0415-E418	0.480		0.111	0.071	0	0	0	0	0	0	0.132	84.1	169.0	
Q033	0.480		0	0	0.011	0.007	0	0	0	0	0.013	85.0	16.9	
SWITCHYARD	230.000		0	0	0	0	0	0	0	0	26.167	84.7	68.8	
SWITCHYARD-3	230.000		0	0	0	0	0	0	0	0	26.167	84.7	68.8	
ZTB45	0.480		0	0	0	0	0	0	0	0	0.008	100.0	10.3	

\* Indicates operating load of a bus exceeds the bus critical limit ( % of the Continuous Ampere rating).

# Indicates operating load of a bus exceeds the bus marginal limit ( % of the Continuous Ampere rating).

AUXILIARY SYSTEM VOLTAGE REGULATION

ICCN C - 130

CCN No. \_\_\_\_\_

Project: E4C-090 REV.3 ICCN C - 130

ETAP

Page: 22

Location: SONGS 2 & 3

5.0.0N

Date: 05-25-2005

Contract:

SN: SCALEDISON

Engineer: W. P. Lennartz

Study Case: 3A14aa

Revision: Base

Filename: E4C090

Config.: 090-3A14aa

ECP 050500255 - 34 ICCN C - 130 UNIT 3 TRAIN A

Branch Loading Summary Report

CKT / Branch		Cable & Reactor			Transformer				
ID	Type	Capacity (Amp)	Loading Amp	%	Capability (MVA)	Loading (Input)		Loading (output)	
						MVA	%	MVA	%
3B01X	Transformer				1.500	0.462	30.8	0.453	30.2
3B02X	Transformer				1.000	0.592	59.2	0.584	58.4
3B03X	Transformer				1.000	0.713	71.3	0.689	68.9
3B04X	Transformer				1.500	1.421	94.8	1.337	89.2
3B12X	Transformer				1.500	0.892	59.5	0.854	57.0
3B13X	Transformer				1.000	0.430	43.0	0.422	42.2
3B16X	Transformer				1.500	1.194	79.6	1.135	75.7
B10X-B	Transformer				1.500	0.761	50.7	0.744	49.6
3XR1	3W XFMR p				40.000	26.167	65.4		
	3W XFMR s				13.300	5.445	40.9		
	3W XFMR t				26.700	19.729	73.9		

\* Indicates a branch with operating load exceeding the branch capability.

AUXILIARY SYSTEM VOLTAGE REGULATION

ICCN C - 130

CCN No. \_\_\_\_\_

Project: E4C-090 REV.3 ICCN C- 130

ETAP

Page: 23

Location: SONGS 2 & 3

5.0.0N

Date: 05-25-2005

Contract:

SN: SCALEDISON

Engineer: W. P. Lennartz

Study Case: 3A14aa

Revision: Base

Filename: E4C090

Config.: 090-3A14aa

ECP 050500255 - 34 ICCN C-130 UNIT 3 TRAIN A

Branch Losses Summary Report

CKT / Branch ID	From-To Bus Flow		To-From Bus Flow		Losses		% Bus Voltage		Vd % Drop in Vmag
	MW	Mvar	MW	Mvar	kW	kvar	From	To	
3XA0304P1	0.388	0.186	-0.388	-0.186	0.0	0.0	97.8	97.8	0.01
3XA0309P1	0.232	0.115	-0.232	-0.115	0.0	0.0	97.8	97.8	0.02
3XA0310P1	0.769	0.453	-0.768	-0.453	0.2	0.1	97.8	97.8	0.02
3XA0311P1	0.612	0.366	-0.612	-0.366	0.1	0.0	97.8	97.8	0.01
3XA0312P1	1.773	0.909	-1.770	-0.907	2.3	2.0	97.8	97.7	0.15
3XXR169PA-PD,P9	-13.773	-7.894	13.797	7.930	23.7	35.2	97.8	98.1	0.23
3AA0402P1	0.456	0.256	-0.456	-0.256	0.0	0.0	100.7	100.7	0.01
3AA0409P1	0.408	0.174	-0.408	-0.174	0.2	0.1	100.7	100.7	0.05
3AA0417P1	1.200	0.763	-1.199	-0.763	0.4	0.3	100.7	100.7	0.04
3XXR169P1-P3	-4.789	-2.567	4.796	2.578	7.4	10.9	100.7	100.9	0.22
3XA0801P1	0.716	0.260	-0.715	-0.259	0.3	0.2	97.8	97.8	0.05
3XA0802P1	0.988	0.671	-0.987	-0.671	0.3	0.2	97.8	97.8	0.03
3XA0808P1	0.399	0.233	-0.399	-0.233	0.1	0.1	97.8	97.8	0.04
3XA0809P1	0.589	0.062	-0.589	-0.062	0.3	0.2	97.8	97.8	0.05
3XXR169P7,P8	-3.487	-1.565	3.492	1.573	5.6	8.3	97.8	98.1	0.22
3XB0102P1	0.266	0.141	-0.265	-0.140	0.7	1.1	93.6	93.3	0.35
3B01X	-0.396	-0.219	0.399	0.233	2.1	14.0	93.6	97.8	4.19
3XB0205P1	0.195	0.001	-0.194	0.000	0.8	0.6	96.5	96.1	0.40
3XB0206P1	0.195	0.001	-0.194	0.000	0.8	0.6	96.5	96.1	0.40
3XB0210P1,P2	0.145	0.001	-0.144	0.000	0.9	0.4	96.5	95.9	0.58
3B02X	-0.583	-0.033	0.589	0.062	5.5	29.0	96.5	97.8	1.29
3XB0306P1	0.241	0.108	-0.238	-0.103	3.0	4.7	94.5	92.8	1.65
3XB0314P1	0.161	0.095	-0.158	-0.091	3.4	4.2	94.5	91.9	2.53
3B03X	-0.608	-0.323	0.612	0.366	3.9	42.9	94.5	97.8	3.36
3AB0403P1	0.014	0.009	-0.014	-0.009	0.0	0.0	94.7	94.7	0.01
3AB0407P1	0.147	0.101	-0.142	-0.096	5.4	5.5	94.7	90.7	4.04
3AB0414P1	0.104	0.056	-0.104	-0.056	0.1	0.1	94.7	94.6	0.11
3AB0415P1	0.227	0.140	-0.226	-0.140	0.3	0.5	94.7	94.6	0.18
3AB0417P1	0.129	0.078	-0.128	-0.077	0.9	0.9	94.7	93.9	0.79
3AB0418P1	0.112	0.072	-0.111	-0.071	1.1	0.6	94.7	93.8	0.89
3XB0402P1	0.186	0.002	-0.184	0.000	2.1	2.1	94.7	93.7	1.06
3B04X	-1.179	-0.631	1.199	0.763	19.9	132.3	94.7	100.7	5.95
3XB1202P1	0.205	0.126	-0.204	-0.123	1.4	2.3	93.7	92.7	0.94
3XB1203P1	0.052	0.027	-0.052	-0.027	0.2	0.3	93.7	93.1	0.54
3XB1211P1	0.180	0.073	-0.175	-0.068	5.2	5.3	93.7	90.4	3.29

AUXILIARY SYSTEM VOLTAGE REGULATION

ICCN C - 130

CCN No. \_\_\_\_\_

Project: E4C-090 REV.3 ICCN C-130  
 Location: SONGS 2 & 3  
 Contract:  
 Engineer: W. P. Lennartz  
 Filename: E4C090

ETAP  
 5.0.0N  
 Study Case: 3A14aa

Page: 24  
 Date: 05-25-2005  
 SN: SCALEDISON  
 Revision: Base  
 Config.: 090-3A14aa

ECP 050500255 - 34 ICCN C-130 UNIT 3 TRAIN A

CKT / Branch ID	From-To Bus Flow		To-From Bus Flow		Losses		% Bus Voltage		Vd % Drop In Vmag
	MW	Mvar	MW	Mvar	kW	kvar	From	To	
3B12X	-0.762	-0.386	0.768	0.453	6.1	67.4	93.7	97.8	4.14
3XB1303P1	0.052	0.026	-0.051	-0.026	0.1	0.1	96.0	95.8	0.26
3XB1305P1	0.108	0.064	-0.107	-0.063	1.0	1.3	96.0	94.9	1.16
3B13X	-0.386	-0.170	0.388	0.186	1.4	15.6	96.0	97.8	1.78
3XB1602P1	0.309	0.145	-0.306	-0.139	3.7	5.7	93.0	91.5	1.56
3XB1603P1,P2	0.379	0.212	-0.370	-0.204	8.1	8.2	93.0	90.7	2.37
3XB1611P1	0.127	0.110	-0.125	-0.108	2.4	2.5	93.0	91.1	1.91
3B16X	-0.977	-0.579	0.987	0.671	10.5	92.0	93.0	97.8	4.77
3ABRA06P1	0.002	0.001	-0.002	-0.001	0.0	0.0	94.7	94.6	0.12
0XB1002P1	0.276	0.147	-0.274	-0.144	2.3	3.6	95.6	94.5	1.13
0XB1014P1	0.280	0.035	-0.279	-0.033	1.4	2.2	95.6	95.1	0.55
0XB1015P1	0.008	0.000	-0.008	0.000	0.0	0.0	95.6	95.4	0.18
B10X-B	-0.710	-0.223	0.715	0.259	5.4	36.6	95.6	97.8	2.17
0XB1015P2	-0.008	0.000	0.008	0.000	0.0	0.0	95.4	95.4	0.04
3XR1	22.161	13.913	-4.796	-2.578	75.5	1832.6	95.4	100.9	0.88
			-17.290	-9.503			95.4	98.1	1.87
					216.7	2372.9			

AUXILIARY SYSTEM VOLTAGE REGULATION

ICCN C - 130

CCN No. \_\_\_\_\_

Project: E4C-090 REV.3 ICCN C-130  
 Location: SONGS 2 & 3  
 Contract:  
 Engineer: W. P. Lennartz  
 Filename: E4C090

ETAP  
 5.0.0N

Study Case: 3A14aa

Page: 25  
 Date: 05-25-2005  
 SN: SCALEDISON  
 Revision: Base  
 Config.: 090-3A14aa

ECP 050500255 - 34 ICCN C-130 UNIT 3 TRAIN A

Equipment Cable and Heater Losses Summary Report

Connected Load		Cable/Heater		Losses		% Voltage			% Vd Operating	% Vst Starting
ID	Type	ID	Library	kW	kvar	Bus	Bus kV	Load kV		
3P117	Ind. Motor	3XA0305P1	8.0MCUN3	3.9	4.5	97.83	97.61	97.61	0.22	96.87
3P115	Ind. Motor	3XA0306P1	8.0MCUN3	3.5	4.1	97.83	97.63	97.63	0.20	96.96
3P051	Ind. Motor	3XA0307P1	8.0MCUN3	1.0	1.4	97.83	97.78	97.78	0.05	97.44
3P050	Ind. Motor	3XA0308P1	8.0MCUN3	0.7	1.0	97.83	97.79	97.79	0.04	97.56
3P120	Ind. Motor	3XA0313P1	8.0MCUN3	3.1	2.0	97.83	97.52	97.52	0.31	96.77
3P307	Ind. Motor	3AA0411P1	8.0MCUN3	0.2	0.1	100.73	100.66	100.66	0.06	100.45
3P012	Ind. Motor	3AA0403P1	8.0MCUN3	0.1	0.1	100.73	100.68	100.68	0.04	100.48
3P024	Ind. Motor	3AA0405P1	8.0MCUN3	0.3	0.2	100.73	100.67	100.67	0.06	100.43
3P017	Ind. Motor	3AA0408P1	8.0MCUN3	0.2	0.1	100.73	100.67	100.67	0.06	100.40
3P141	Ind. Motor	3AA0404P1	8.0MCUN3	1.0	0.6	100.73	100.57	100.57	0.15	100.00
3P015	Ind. Motor	3AA0407P1	8.0MCUN3	0.2	0.1	100.73	100.67	100.67	0.05	100.48
3E202	Ind. Motor	3XAC803P1	8.0MCUN3	0.4	0.2	97.85	97.80	97.80	0.05	97.63
3P018	Ind. Motor	3WAD004P1	8.0MCUN3	0.0	0.0	100.68	100.68	100.68	0.01	100.65
3P058	Ind. Motor	3XA0312P2	5.0MCUS1	0.4	0.4	97.69	97.66	97.66	0.03	97.54
C443	Ind. Motor	0XAC101P2	8.0MCUN1	0.0	0.0	97.81	97.80	97.80	0.01	97.74
E336	Ind. Motor	0AAD007P1	8.0MCUN3	0.2	0.1	100.72	100.68	100.68	0.04	100.35
3E397	Ind. Motor	3XB0106P1-P3	0.6MCUN1	0.5	0.2	93.62	92.84	96.88	0.78	90.68
3P128	Ind. Motor	3XB0110P1	0.6MCUN1	1.5	0.7	93.62	92.03	96.03	1.59	87.51
3E394	Ind. Motor	3XB0209P1-P3	0.6MCUN1	0.6	0.2	96.51	95.41	99.56	1.10	92.13
3P075	Ind. Motor	3XB0303P1	0.6MCUN1	0.7	0.3	94.46	93.60	97.67	0.87	91.75
3P250	Ind. Motor	3XB0309P1	0.6MCUN1	0.5	0.2	94.46	93.67	97.75	0.79	92.08
3A001	Ind. Motor	3XB0310P1-P2	0.6MCUN1	1.3	0.5	94.46	93.12	97.17	1.35	90.15
3A074	Ind. Motor	3AB0419P1-P3	0.6MCUN1	0.9	0.4	94.74	93.03	97.08	1.71	87.23
3A071	Ind. Motor	3AB0409P1-P3	0.6MCUN1	0.8	0.3	94.74	93.21	97.26	1.53	87.99
3E399	Ind. Motor	3AB0410P1-P3	0.6MCUN1	0.6	0.3	94.74	93.78	97.85	0.96	88.47
3E401	Ind. Motor	3AB0411P1-P3	0.6MCUN1	0.6	0.3	94.74	93.77	97.85	0.97	88.45
3P190	Ind. Motor	3AB0413P1	0.6MCUN1	0.6	0.3	94.74	93.78	97.85	0.96	90.11
3P127	Ind. Motor	3XB1206P1-P3	0.6MCUN1	5.5	6.8	93.67	90.41	94.34	3.26	78.23
3P135	Ind. Motor	3XB1306P1	0.6MCUN1	6.7	4.6	96.04	91.48	95.46	4.56	79.48
3LD46	Ind. Motor	3XB1606P1-P2	0.6MCUN1	0.6	0.5	93.05	92.32	96.33	0.73	87.01
3A274	Ind. Motor	3ABD12P1	0.6MCUN3	0.1	0.0	90.70	90.52	94.45	0.18	90.20
3A275	Ind. Motor	3ABD13P1	0.6MCUN3	0.2	0.0	90.70	90.32	94.25	0.37	89.65
3E550	Ind. Motor	3ABD21P1	0.6MCUN3	0.3	0.1	90.70	90.08	94.00	0.62	89.03
3E546	Ind. Motor	3ABD22P1	0.6MCUN3	0.2	0.0	90.70	90.19	94.11	0.51	89.32

AUXILIARY SYSTEM VOLTAGE REGULATION

ICCN C - 130

CCN No. \_\_\_\_\_

Project: E4C-090 REV.3 ICCN C-130

ETAP

Page: 26

Location: SONGS 2 & 3

5.0.0N

Date: 05-25-2005

Contract:

SN: SCALEDISON

Engineer: W. P. Lennartz

Study Case: 3A14aa

Revision: Base

Filename: E4C090

Config.: 090-3A14aa

ECP 050500255 - 34 ICCN C-130 UNIT 3 TRAIN A

Equipment Cable and Heater Losses Summary Report

Connected Load		Cable/Heater		Losses		% Voltage			% Vd Operating	% Vst Starting
ID	Type	ID	Library	kW	kvar	Bus	Bus kV	Load kV		
3P093	Ind. Motor	3ABD23P1	0.6MCUN3	0.0	0.0	90.70	90.58	94.52	0.12	90.48
3P096	Ind. Motor	3ABD24P1	0.6MCUN3	0.0	0.0	90.70	90.58	94.52	0.12	90.48
3P997/3P1014	Ind. Motor	3ABD11P1	0.6MCUN3	0.0	0.0	90.70	90.59	94.53	0.11	90.51
3P996/3P1015	Ind. Motor	3ABD10P1	0.6MCUN3	0.0	0.0	90.70	90.50	94.44	0.20	90.36
3HV4731	Ind. Motor	3ABE36P1	0.6MCUN3	0.0	0.0	94.63	94.00	98.09	0.64	93.41
3A373	Ind. Motor	3ABY08P1	0.6MCUN3	0.1	0.0	94.56	93.01	97.05	1.55	89.71
3A370	Ind. Motor	3ABY07P1	0.6MCUN3	0.1	0.0	94.56	93.37	97.42	1.20	90.97
3P1018	Ind. Motor	3ABY10P1	0.6MCUN3	0.1	0.0	94.56	93.12	97.17	1.44	91.92
3E439	Ind. Motor	3ABY11P1	0.6MCUN3	0.0	0.0	94.56	94.50	98.61	0.06	93.94
3E440	Ind. Motor	3ABY12P1	0.6MCUN3	0.0	0.0	94.56	94.50	98.61	0.06	93.94
3P174	Ind. Motor	3ABY14P1	0.6MCUN3	0.5	0.0	94.56	92.84	96.87	1.73	91.27
3P175	Ind. Motor	3ABY15P1	0.6MCUN3	0.5	0.0	94.56	92.84	96.87	1.73	91.27
3E437	Ind. Motor	3ABY20P1	0.6MCUN3	0.0	0.0	94.56	94.46	98.57	0.10	93.87
3E438	Ind. Motor	3ABY21P1	0.6MCUN3	0.0	0.0	94.56	94.46	98.57	0.10	93.87
3E427	Ind. Motor	3ABY22P1	0.6MCUN3	0.0	0.0	94.56	94.25	98.35	0.31	93.51
3E417	Ind. Motor	3ABY24P1	0.6MCUN3	0.1	0.0	94.56	93.20	97.26	1.36	91.12
3E517	Ind. Motor	3ABY25P1	0.6MCUN3	0.0	0.0	94.56	94.28	98.38	0.29	93.34
3E453	Ind. Motor	3ABY30P1	0.6MCUN3	0.0	0.0	94.56	94.33	98.43	0.24	93.57
3E454	Ind. Motor	3ABY31P1	0.6MCUN3	0.0	0.0	94.56	94.35	98.45	0.21	93.75
3P009	Ind. Motor	3ABY34P1	0.6MCUN3	0.3	0.0	94.56	93.53	97.60	1.03	91.71
3A394	Ind. Motor	3ABY36P1	0.6MCUN3	0.1	0.0	94.56	92.85	96.89	1.71	88.91
3E441	Ind. Motor	3ABY37P1	0.6MCUN3	0.0	0.0	94.56	94.27	98.37	0.29	93.70
3E370	Ind. Motor	3ABY38P1	0.6MCUN3	1.0	0.2	94.56	92.74	96.77	1.83	89.62
P159	Ind. Motor	0XB1006P1	0.6MCUN1	1.4	0.5	95.63	93.76	97.84	1.87	89.55
P162	Ind. Motor	0ABQ24P1	0.6MCUN3	0.4	0.1	93.95	92.72	96.75	1.23	90.32
2A173	Ind. Motor	0ABQ07P1	0.6MCUN3	0.0	0.0	93.95	93.10	97.15	0.84	90.91
2E255	Ind. Motor	0ABQ08P1	0.6MCUN3	0.1	0.0	93.95	93.09	97.14	0.85	91.67
A207	Ind. Motor	0ABQ09P2	0.6MCUN3	0.4	0.0	93.95	90.60	94.54	3.34	86.93
3A173	Ind. Motor	0ABQ14P1	0.6MCUN3	0.0	0.0	93.95	93.07	97.11	0.88	90.81
3E255	Ind. Motor	0ABQ15P1	0.6MCUN3	0.1	0.0	93.95	92.57	96.60	1.37	90.05
P445	Ind. Motor	0ABQ20P1	0.6MCUN3	0.0	0.0	93.95	93.15	97.20	0.80	92.49
A053	Ind. Motor	0ABQ22P1	0.6MCUN3	0.1	0.0	93.95	92.74	96.77	1.21	89.86
A056	Ind. Motor	0ABQ23P1	0.6MCUN3	0.0	0.0	93.95	93.53	97.60	0.41	91.80
W310	Ind. Motor	0ABQ25P1	0.6MCUN3	0.0	0.0	93.95	92.92	96.96	1.02	92.11

**AUXILIARY SYSTEM VOLTAGE REGULATION**

**ICCN C - 130**

CCN No. \_\_\_\_\_

Project: E4C-090 REV.3 ICCN C - 130

ETAP

Page: 27

Location: SONGS 2 & 3

5.0.0N

Date: 05-25-2005

Contract:

SN: SCALEDISON

Engineer: W. P. Lennartz

Study Case: 3A14aa

Revision: Base

Filename: E4C090

Config.: 090-3A14aa

ECP 050500255 - 34 ICCN C - 130 UNIT 3 TRAIN A

Equipment Cable and Heater Losses Summary Report

Connected Load		Cable/Heater		Losses		% Voltage			% Vd Operating	% Vst Starting
ID	Type	ID	Library	kW	kvar	Bus	Bus kV	Load kV		
E418	End. Motor	0ABD415P1	0.6MCUN1	3.1	1.7	93.85	91.35	95.33	2.50	81.87
2L270	St. Load	0ABQ05P1	0.6MCUN3	0.1	0.0	93.95	92.27	92.27	1.68	0.00
3B001	St. Load	3ABY03P1	0.6MCUN1	0.1	0.0	94.56	94.27	94.27	0.29	0.00
3B003	St. Load	3ABE04P1	0.6MCUN1	0.1	0.0	94.63	94.35	94.35	0.28	0.00
3B005	St. Load	3XB1609P2	0.6MCUN1	0.8	0.5	93.05	92.19	92.19	0.85	0.00
3E122-H1	St. Load	3XB0210P3-P5	0.6MCUN3	0.6	0.1	95.94	94.73	94.73	1.21	0.00
3E124-H1	St. Load	3XB0206P2-P4	0.6MCUN3	0.6	0.1	96.11	94.87	94.87	1.24	0.00
3E126-H1	St. Load	3XBC205P2,P3,PE	0.6MCUN3	0.6	0.1	96.11	94.90	94.90	1.20	0.00
3E128-H1 [X]	St. Load	3XB0402P2,P3,P4	0.6MCUN3	0.6	0.1	93.68	92.38	92.38	1.30	0.00
3E370H	St. Load	3ABY39P6	0.6MCUN3	0.0	0.0	94.56	94.32	94.32	0.25	0.00
3E399H	St. Load	3ABY40P6,P7,P8	0.6MCUN3	0.0	0.0	94.56	94.38	94.38	0.19	0.00
3E401H	St. Load	3ABY40P9,PA,PB	0.6MCUN3	0.0	0.0	94.56	94.41	94.41	0.15	0.00
3E464	St. Load	3ABE03P1,P2	0.6MCUN3	0.3	0.0	94.63	93.57	93.57	1.07	0.00
3E652	St. Load	3ABE49P1,P2	0.6MCUN3	0.1	0.0	94.63	93.12	93.12	1.51	0.00
3L266	St. Load	3ABE42P1	0.6MCUN3	0.2	0.0	94.63	93.48	93.48	1.16	0.00
3L270	St. Load	0ABQ06P1	0.6MCUN3	0.2	0.0	93.95	91.30	91.30	2.64	0.00
3L411[X]	St. Load	3XBY23P1	0.6MCUN3	0.0	0.0	94.56	94.44	94.44	0.12	0.00
3P012H	St. Load	3ABY40P1	0.6MCUN3	0.0	0.0	94.56	93.37	93.37	1.19	0.00
3P015H	St. Load	3ABY39P1	0.6MCUN3	0.0	0.0	94.56	93.38	93.38	1.18	0.00
3P017H	St. Load	3ABY39P2	0.6MCUN3	0.0	0.0	94.56	92.82	92.82	1.74	0.00
3P018HA	St. Load	3ABY39P3	0.6MCUN3	0.0	0.0	94.56	93.28	93.28	1.28	0.00
3P112H	St. Load	3ABY39P4	0.6MCUN3	0.0	0.0	94.56	94.25	94.25	0.31	0.00
3P141H	St. Load	3ABY39P8	0.6MCUN3	0.0	0.0	94.56	93.74	93.74	0.82	0.00
3P174H	St. Load	3ABY40P2	0.6MCUN3	0.0	0.0	94.56	94.48	94.48	0.08	0.00
3P175H	St. Load	3ABY40P3	0.6MCUN3	0.0	0.0	94.56	94.50	94.50	0.06	0.00
3P190H	St. Load	3ABY40P4	0.6MCUN3	0.0	0.0	94.56	94.48	94.48	0.08	0.00
3P191HA	St. Load	3ABY40P5	0.6MCUN3	0.0	0.0	94.56	94.50	94.50	0.07	0.00
3P307H	St. Load	3ABY39P5	0.6MCUN3	0.0	0.0	94.56	94.26	94.26	0.30	0.00
3P1018H	St. Load	3ABY39P9	0.6MCUN3	0.0	0.0	94.56	94.48	94.48	0.08	0.00
3RU7804-I	St. Load	3ABE41P1	0.6MCUN3	0.0	0.0	94.63	94.00	94.00	0.64	0.00
3RU7822-1	St. Load	3ABE02P1	0.6MCUN3	0.0	0.0	94.63	93.25	93.25	1.38	0.00
3TD11	St. Load	3XB1210P1	0.6MCUN1	1.1	1.2	93.67	92.64	92.64	1.04	0.00
3TD14[X]	St. Load	3XA0412P1	8.0MCUN3	0.0	0.0	100.73	100.70	100.70	0.03	0.00
3T110/3Q071[X]	St. Load	3XBY33P2,P3	0.6MCUN1	0.9	0.2	94.56	90.82	90.82	3.74	0.00



AUXILIARY SYSTEM VOLTAGE REGULATION

ICCN C - 130

CCN No. \_\_\_\_\_

Project: E4C-090 REV.3 ICCN C - 130

ETAP

Page: 28

Location: SONGS 2 & 3

5.0.0N

Date: 05-25-2005

Contract:

SN: SCALEDISON

Engineer: W. P. Lennartz

Study Case: 3A14aa

Revision: Base

Filename: E4C090

Config.: 090-3A14aa

ECP 050500255 - 34 ICCN C - 130 UNIT3 TRAIN A

Equipment Cable and Heater Losses Summary Report

Connected Load		Cable/Heater		Losses		% Voltage			% Vd Operating	% Vst Starting
ID	Type	ID	Library	kW	kvar	Bus	Bus kV	Load kV		
E297	St. Load	0ABQ04P1,P2	0.6MCUN3	0.1	0.0	93.95	91.99	91.99	1.96	0.00
E643	St. Load	0XB1011P1	0.6MCUN1	0.2	0.3	95.63	95.38	95.38	0.25	0.00
E645	St. Load	0XB1015P3	0.6MCUN3	0.0	0.0	95.41	95.36	95.36	0.05	0.00
L211-1	St. Load	0ABQ13P1	0.6MCUN3	0.1	0.0	93.95	93.64	93.64	0.31	0.00
L211-4	St. Load	0ABQ26P1	0.6MCUN3	0.1	0.0	93.95	93.54	93.54	0.41	0.00
L437(X)	St. Load	0XBQ11P1	0.6MCUN3	0.1	0.0	93.95	92.94	92.94	1.01	0.00
LP35A(X)	St. Load	3XBY19P1	0.6MCUN3	0.1	0.0	94.56	93.65	93.65	0.91	0.00
N002	St. Load	3XB1307P1	0.6MCUN1	2.9	1.1	96.04	92.35	92.35	3.69	0.00

**AUXILIARY SYSTEM VOLTAGE REGULATION**

ICCN C - 130

CCN No. \_\_\_\_\_

Project: E4C-090 REV.3 ICCN C - 130

ETAP

Page: 29

Location: SONGS 2 & 3

5.0.0N

Date: 05-25-2005

Contract:

SN: SCALEDISON

Engineer: W. P. Lennartz

Study Case: 3A14aa

Revision: Base

Filename: E4C090

Config.: 090-3A14aa

ECP 050500255 - 34 ICCN C - 130 UNIT3 TRAJN A

Alert Summary Report

% Alert Settings

Critical

Loading

Bus	0.0	0.0
Cable	0.0	0.0
Reactor	0.0	0.0
Line	100.0	95.0
Transformer	0.0	0.0
Panel	100.0	95.0
Protective Device	0.0	0.0
Generator	0.0	0.0

Bus Voltage

OverVoltage	130.0	1000.0
UnderVoltage	70.0	-100.0

Generator Excitation

OverExcited (Q Max.)	0.0	0.0
UnderExcited (Q Min.)		

Critical Report

ID	Device Type	Rating	Unit	Calculated	%Mag.	Condition
2G002	Generator	0.000	MW	0.000		UnderPower
2G003	Generator	0.000	MW	0.000		UnderPower
3G002	Generator	0.000	MW	0.000		UnderPower
3G003	Generator	0.000	MW	0.000		UnderPower

## AUXILIARY SYSTEM VOLTAGE REGULATION

ICCN C - 130

CCN No. \_\_\_\_\_

Project: E4C-090 REV.3 ICCN C-130

ETAP

Page: 30

Location: SONGS 2 &amp; 3

5.0.0N

Date: 05-25-2005

Contract:

SN: SCALEDISON

Engineer: W. P. Lennartz

Study Case: 3A14aa

Revision: Base

Filename: E4C090

Config.: 090-3A14aa

ECP 050500255-34 ICCN C-130 UNIT3 TRAIN A

SUMMARY OF TOTAL GENERATION, LOADING & DEMAND

	<u>MW</u>	<u>Mvar</u>	<u>MVA</u>	<u>% PF</u>
Source (Swing Buses):	22.161	13.913	26.167	84.69 Lagging
Source (Non-Swing Buses):	0.000	0.000	0.000	100.00 Lagging
Total Demand:	22.161	13.913	26.167	84.69 Lagging
Total Motor Load:	19.072	10.655	21.847	87.30 Lagging
Total Static Load:	2.872	0.885		
Apparent Losses:	0.217	2.373		
System Mismatch:	0.000	0.000		

Number of Iterations: 1

## AUXILIARY SYSTEM VOLTAGE REGULATION

ICCN C - 130

CCN No. \_\_\_\_\_

Project: E4C-090 REV.3 ICCN C - 130

ETAP

Page: 1

Location: SONGS 2 &amp; 3

5.0.0N

Date: 05-24-2005

Contract:

SN: SCALEDISON

Engineer: W. P. Lennartz

Study Case: 3A14aa

Revision: Base

Filename: E4C090

Config.: 090-3A14aa

ECP 050500255 - 34 ICCN C - 130 UNIT 3 TRAIN A

Electrical Transient Analyzer ProgramLoad Flow Analysis

Loading Category (1): Design-BHP

Generation Category (1): Design

Load Diversity Factor: None

	<u>Swing</u>	<u>V-Control</u>	<u>Load</u>	<u>Total</u>
Number of Buses:	5	0	75	80

	<u>XFMR2</u>	<u>XFMR3</u>	<u>Reactor</u>	<u>Line/Cable</u>	<u>Impedance</u>	<u>Tie PD</u>	<u>Total</u>
Number of Branches:	8	1	0	41	0	24	74

Method of Solution: Newton-Raphson Method

Maximum No. of Iteration: 10

Precision of Solution: 0.001000

System Frequency: 60 Hz

Unit System: English

Project Filename: E4C090

Output Filename: C:\wpfiles\ETAPDATA\086-088-090\3A14aa.lfr

AUXILIARY SYSTEM VOLTAGE REGULATION

ICCN C - 130

CCN No. \_\_\_\_\_

Project: E4C-090 REV.3 ICCN C - 130

ETAP

Page: 2

Location: SONGS 2 & 3

5.0.0N

Date: 05-24-2005

Contract:

SN: SCALEDISON

Engineer: W. P. Lennartz

Study Case: 3A14aa

Revision: Base

Filename: E4C090

Config.: 090-3A14aa

ECP 050500255 - 34 ICCN C-130 UNIT 3 TRAIN A

Adjustments

<u>Tolerance</u>	<u>Apply Adjustments</u>	<u>Individual /Global</u>	<u>Percent</u>
Transformer Impedance:	Yes	Individual	
Reactor Impedance:	Yes	Individual	
Overload Heater Resistance:	No		
Transmission Line Length:	No		
Cable Length:	No		

<u>Temperature Correction</u>	<u>Apply Adjustments</u>	<u>Individual /Global</u>	<u>Degree C</u>
Transmission Line Resistance:	Yes	Individual	
Cable Resistance:	Yes	Individual	

AUXILIARY SYSTEM VOLTAGE REGULATION

ICCN C - 130

CCN No. \_\_\_\_\_

Project: E4C-090 REV.3 ICCN C-130  
 Location: SONGS 2 & 3  
 Contract:  
 Engineer: W. P. Lennartz  
 Filename: E4C090

ETAP  
 5.0.0N  
 Study Case: 3A14aa

Page: 3  
 Date: 05-24-2005  
 SN: SCALEDISON  
 Revision: Base  
 Config.: 090-3A14aa

ECP 050500255 - 34 ICCN C-130 UNIT 3 TRAIN A

Bus Input Data

Bus			Initial Voltage		Load							
ID	kV	Sub-sys	% Mag.	Ang.	Constant kVA		Constant Z		Constant I		Generic	
					MW	Mvar	MW	Mvar	MW	Mvar	MW	Mvar
2G002-BUS	4.160	2	105.3	0.0								
2G003-BUS	4.160	3	105.3	0.0								
3A03	4.160	1	96.5	-4.1	10.000	5.865						
3A04	4.160	1	99.5	-1.6	2.596	1.294	0.127	0.079				
3A08	4.160	1	96.6	-4.1	0.796	0.339						
3B01	0.480	1	92.4	-5.5	0.131	0.078						
3B01XHS	4.160	1	96.5	-4.1								
3B02	0.480	1	95.2	-6.9	0.049	0.031						
3B02XHS	4.160	1	96.5	-4.1								
3B03	0.480	1	93.1	-7.1	0.206	0.120						
3B03XHS	4.160	1	96.5	-4.1								
3B04	0.480	1	93.4	-6.0	0.261	0.172						
3B04XHS	4.160	1	99.4	-1.6								
3B12	0.480	1	92.4	-7.9	0.202	0.118	0.141	0.047				
3B12XHS	4.160	1	96.5	-4.1								
3B13	0.480	1	94.7	-6.0	0.152	0.079	0.082	0.001				
3B13XHS	4.160	1	96.5	-4.1								
3B16	0.480	1	91.8	-7.7	0.089	0.043	0.084	0.078				
3B16XHS	4.160	1	96.5	-4.1								
3B1611BP	0.480	1	89.9	-7.8	0.006	0.004	0.143	0.125				
3BA	0.480	1	92.0	-5.7	0.153	0.097	0.129	0.049				
3BB	0.480	1	90.6	-7.7	0.138	0.087	0.024	0.006				
3BC	0.480	1	93.6	-6.2	0.041	0.030	0.073	0.036				
3BD	0.480	1	89.3	-6.5	0.130	0.088						
3BD18-IITRS	0.480	1	89.3	-6.5								
3BDMM	0.460	1	93.2	-6.5	0.005	0.003						
3BDSM	0.480	1	89.3	-6.5			0.004	0.003				
3BE	0.480	1	93.3	-6.0	0.001	0.001	0.084	0.042				
3BEMM	0.460	1	97.4	-6.0	0.005	0.003						
3BESM	0.480	1	93.3	-6.0			0.004	0.003				
3BF	0.480	1	91.5	-7.7	0.104	0.052	0.156	0.059				
3BHP01	0.480	1	94.7	-7.1			0.157	0.000				
3BHP02	0.480	1	94.8	-7.1			0.210	0.000				
3BHP03	0.480	1	94.8	-7.1			0.210	0.000				

AUXILIARY SYSTEM VOLTAGE REGULATION

ICCN C - 130

CCN No. \_\_\_\_\_

Project: E4C-090 REV.3 ICCN C-130

ETAP

Page: 4

Location: SONGS 2 & 3

5.00N

Date: 05-24-2005

Contract:

SN: SCALEDISON

Engineer: W. P. Lennartz

Study Case: 3A14aa

Revision: Base

Filename: E4C090

Config.: 090-3A14aa

ECP 050500255 - 34 ICCN C - 130 UNIT 3 TRAIN A

Bus	Load												
	ID	kV	Sub-sys	Initial Voltage		Constant kVA		Constant Z		Constant I		Generic	
				% Mag.	Ang.	MW	Mvar	MW	Mvar	MW	Mvar	MW	Mvar
3BHP04	0.480	1		92.4	-6.7			0.210	0.000				
3BLX	0.480	1		91.8	-8.0	0.036	0.023	0.018	0.005				
3BMX	0.480	1		94.5	-6.0	0.035	0.022	0.018	0.005				
3BRA	0.480	1		93.4	-6.0								
3BRAMM	0.460	1		97.5	-6.0	0.005	0.003						
3BRASM	0.480	1		93.4	-6.0			0.004	0.003				
3BV	0.480	1		91.4	-8.1	0.101	0.073	0.119	0.059				
3BX	0.480	1		90.2	-8.3	0.107	0.070	0.238	0.083				
3BY	0.480	1		93.3	-6.1	0.139	0.082	0.061	0.048				
3BY39-HTRS	0.480	1		93.3	-6.1			0.008	0.000				
3BY40-HTRS	0.480	1		93.3	-6.1			0.003	0.000				
3BYMM	0.460	1		97.3	-6.1	0.005	0.003						
3BYSM	0.480	1		93.3	-6.1			0.004	0.003				
3D004-3A0409	4.160	1		99.4	-1.6								
3D004-3F018	4.160	1		99.4	-1.6	0.408	0.174						
3G002-BUS	4.160	5		105.3	0.0								
3G003-BUS	4.160	4		105.3	0.0								
3HV9377-N	0.480	-1		93.3	-6.0			0.002	0.001				
3L111	0.480	1		89.0	-8.8	0.125	0.049	0.062	0.024				
3L707-3BRA06	0.480	1		93.3	-6.0								
3PEXCCS	4.160	1		96.4	-4.1	1.770	0.907						
3Q020	0.480	1		89.3	-6.5			0.004	0.003				
3Q039	0.480	1		93.3	-6.1			0.017	0.011				
3Q074	0.480	1		93.4	-6.0			0.004	0.003				
3T063	0.480	1		93.3	-6.0			0.021	0.013				
3XR1-X	4.160	1		99.7	-1.6								
3XR1-Y	4.160	1		96.8	-4.0								
ASCI	4.160	1		96.5	-4.1	0.232	0.115						
B10	0.480	1		94.3	-6.7	0.063	0.040	0.090	0.000				
B10XBHS	4.160	1		96.5	-4.1								
BO	0.480	1		93.8	-7.1	0.021	0.014	0.286	0.020				
BP	0.480	1		93.2	-7.0	0.163	0.108	0.125	0.040				
BQ	0.480	1		92.6	-6.2	0.061	0.038	0.054	0.030				
BQMM	0.460	1		96.7	-6.2	0.005	0.003						
BQSM	0.480	1		92.6	-6.2			0.004	0.003				
BT	0.480	1		89.4	-8.1	0.168	0.103	0.246	0.127				

AUXILIARY SYSTEM VOLTAGE REGULATION

ICCN C - 130

CCN No. \_\_\_\_\_

Project: E4C-090 REV.3 ICCN C-130

ETAP

Page: 5

Location: SONGS 2 & 3

5.0.0N

Date: 05-24-2005

Contract:

SN: SCALEDISON

Engineer: W. P. Lennartz

Study Case: 3A14aa

Revision: Base

Filename: E4C090

Config.: 090-3A14aa

ECP 050500255 - 34 ICCN C-130 UNIT 3 TRAIN A

Bus				Initial Voltage		Load							
ID	kV	Sub-sys		% Mag.	Ang.	Constant kVA		Constant Z		Constant I		Generic	
						MW	Mvar	MW	Mvar	MW	Mvar	MW	Mvar
BT-3B1603	0.480	1		89.4	-8.1								
D007-3A0402	4.160	1		99.5	-1.6								
D007-E336	4.160	1		99.5	-1.6	0.456	0.256						
D645	0.480	1		94.1	-6.7			0.009	0.000				
DB0415-3B0418	0.480	1		92.5	-6.0								
DB0415-E418	0.480	1		92.5	-6.0	0.111	0.071						
Q033	0.480	1		92.6	-6.2			0.013	0.008				
SWITCHYARD	230.000	1		94.3	0.0								
SWITCHYARD-3	230.000	1		94.3	0.0								
ZTB45	0.480	1		94.2	-6.7								
Total Number of Buses: 80						19.073	10.656	3.245	1.015	0.000	0.000	0.000	0.000

Generation Bus				Voltage		Generation			Mvar Limits	
ID	kV	Type	Sub-sys	% Mag.	Angle	MW	Mvar	% PF	Max	Min
2G002-BUS	4.160	Swing	2	105.3	0.0					
2G003-BUS	4.160	Swing	3	105.3	0.0					
3G002-BUS	4.160	Swing	5	105.3	0.0					
3G003-BUS	4.160	Swing	4	105.3	0.0					
SWITCHYARD	230.000	Swing	1	94.3	0.0					
						0.000	0.000			



**AUXILIARY SYSTEM VOLTAGE REGULATION**

**ICCN C - 130**

CCN No. \_\_\_\_\_

Project: E4C-090 REV.3 ICCN C-130

ETAP

Page: 6

Location: SONGS 2 & 3

5.0.0N

Date: 05-24-2005

Contract:

SN: SCALEDISON

Engineer: W. P. Lemartz

Study Case: 3A14aa

Revision: Base

Filename: E4C090

Config.: 090-3A14aa

ECP 050500255 - 34 ICCN C-130 UNIT 3 TRAIN A

Line/Cable Input Data

Ohms or Siemens/1000 ft per Conductor (Cable) or per Phase (Line)

Line/Cable ID	Library	Size	Length		#/Phase	T (°C)	R	X	Y
			Adj. (ft)	% Tol.					
0XB1002P1	0.6MCUN1	750	175.0	0.0	1	75	0.028000	0.043800	
0XB1014P1	0.6MCUN1	750	131.0	0.0	1	75	0.028000	0.043800	
0XB1015P1	0.6MCUN1	170	378.0	0.0	1	75	0.131000	0.049500	
0XB1015P2	0.6MCUN1	6	20.0	0.0	1	75	0.498000	0.059800	
3AA0402P1	8.0MCUN3	250	48.0	0.0	1	75	0.054700	0.035600	
3AA0409P1	8.0MCUN3	250	278.0	0.0	1	75	0.054700	0.035600	
3AA0417P1	8.0MCUN3	250	70.0	0.0	1	75	0.054700	0.035600	
3AB0403P1	0.6MCUN1	350	31.0	0.0	1	75	0.046100	0.046900	
3AB0407P1	0.6MCUN1	350	765.0	0.0	1	75	0.046100	0.046900	
3AB0414P1	0.6MCUN1	350	31.0	0.0	1	75	0.046100	0.046900	
3AB0415P1	0.6MCUN1	750	31.0	0.0	1	75	0.028000	0.043800	
3AB0417P1	0.6MCUN1	350	181.0	0.0	1	75	0.046100	0.046900	
3AB0418P1	0.6MCUN1	370	148.0	0.0	1	75	0.086000	0.048600	
3ABRA06P1	0.6MCUN3	10	125.0	0.0	1	75	1.240000	0.044800	
3XA0304P1	8.0MCUN3	250	66.0	0.0	1	75	0.054700	0.035600	
3XA0309P1	8.0MCUN3	250	224.0	0.0	1	75	0.054700	0.035600	
3XA0310P1	8.0MCUN3	250	60.0	0.0	1	75	0.054700	0.035600	
3XA0311P1	8.0MCUN3	250	40.0	0.0	1	75	0.054700	0.035600	
3XA0312P1	8.0MCUN3	350	240.0	0.0	1	75	0.040000	0.034800	
3XA0801P1	8.0MCUN3	250	170.0	0.0	1	75	0.054700	0.035600	
3XA0802P1	8.0MCUN3	250	60.0	0.0	1	75	0.054700	0.035600	
3XA0808P1	8.0MCUN3	250	203.0	0.0	1	75	0.054700	0.035600	
3XA0809P1	8.0MCUN3	250	232.0	0.0	1	75	0.054700	0.035600	
3XB0102P1	0.6MCUN1	750	56.0	0.0	1	75	0.028000	0.043800	
3XB0205P1	0.6MCUN1	470	66.0	0.0	1	75	0.070000	0.048200	
3XB0206P1	0.6MCUN1	470	66.0	0.0	1	75	0.070000	0.048200	
3XB0210P1,P2	0.6MCUN1	270	83.0	0.0	1	75	0.106000	0.049000	
3XB0306P1	0.6MCUN1	750	314.0	0.0	1	75	0.028000	0.043800	
3XB0314P1	0.6MCUN1	500	549.0	0.0	1	75	0.035900	0.045000	
3XB0402P1	0.6MCUN1	350	268.0	0.0	1	75	0.046100	0.046900	
3XB1202P1	0.6MCUN1	750	181.0	0.0	1	75	0.028000	0.043800	
3XB1203P1	0.6MCUN1	500	377.0	0.0	1	75	0.035900	0.045000	
3XB1211P1	0.6MCUN1	350	605.0	0.0	1	75	0.046100	0.046900	
3XB1303P1	0.6MCUN1	500	189.0	0.0	1	75	0.035900	0.045000	

## AUXILIARY SYSTEM VOLTAGE REGULATION

ICCN C - 130

CCN No. \_\_\_\_\_

Project: E4C-090 REV.3 ICCN C-130

ETAP

Page: 7

Location: SONGS 2 &amp; 3

5.0.0N

Date: 05-24-2005

Contract:

SN: SCALEDISON

Engineer: W. P. Lennartz

Study Case: 3A14aa

Revision: Base

Filename: EAC090

Config.: 090-3A14aa

ECP 050500255 - 34 ICCN C - 130 UNIT 3 TRAIN A

## Ohms or Siemens/1000 ft per Conductor (Cable) or per Phase (Line)

Line/Cable	Library	Size	Length		#/Phase	T (°C)	R	X	Y
			Adj. (ft)	% Tol.					
3XB1305P1	0.6MCUN1	500	380.0	0.0	1	75	0.035900	0.045300	
3XB1602P1	0.6MCUN1	750	224.0	0.0	1	75	0.028000	0.043800	
3XB1603P1,P2	0.6MCUN1	350	371.0	0.0	2	75	0.046100	0.046900	
3XB1611P1	0.6MCUN1	350	370.0	0.0	1	75	0.046100	0.046900	
3XXR169P1-P3	8.0MCUN3	750	631.0	0.0	3	75	0.020800	0.030900	
3XXR169P7,P8	8.0MCUN3	750	610.0	0.0	2	75	0.020800	0.030900	
3XXR169PA-PD,P9	8.0MCUN3	750	374.0	0.0	5	75	0.020800	0.030900	

Line / Cable resistances are listed at the specified temperatures.

AUXILIARY SYSTEM VOLTAGE REGULATION

ICCN C - 130

CCN No. \_\_\_\_\_

Project: E4C-090 REV.3 ICCN C-130  
 Location: SONGS 2 & 3  
 Contract:  
 Engineer: W. P. Lennartz  
 Filename: E4C090

ETAP  
 5.0.0N

Study Case: 3A14aa

Page: 8  
 Date: 05-24-2005  
 SN: SCALEDISON  
 Revision: Base  
 Config.: 090-3A14aa

ECP 050500255 - 34 ICCN C - 130 UNIT 3 TRAIN A

2-Winding Transformer Input Data

Transformer ID	Rating			Z Variation			% Tap Setting		Adjusted % Z	Phase Shift			
	MVA	Prim. kV	Sec. kV	% Z	X/R	+5%	-5%	% Tol.		Prim.	Sec.	Type	Angle
3B01X	1.500	4.160	0.480	9.09	6.80	0	0	0	2.500	0	9.0900	Std Pos. Seq.	0.0
3B02X	1.000	4.160	0.480	8.05	5.30	0	0	0	0	0	8.0500	Std Pos. Seq.	0.0
3B03X	1.000	4.160	0.480	8.09	10.92	0	0	0	0	0	8.0900	Std Pos. Seq.	0.0
3B04X	1.500	4.160	0.480	10.07	6.64	0	0	0	0	0	10.0700	Std Pos. Seq.	0.0
3B12X	1.000	4.160	0.480	8.14	11.08	0	0	0	0	0	8.1400	Std Pos. Seq.	0.0
3B13X	1.000	4.160	0.480	8.13	10.96	0	0	0	0	0	8.1300	Std Pos. Seq.	0.0
3B16X	1.500	4.160	0.480	9.33	8.75	0	0	0	0	0	9.3300	Std Pos. Seq.	0.0
B10X-B	1.500	4.160	0.480	9.17	6.72	0	0	0	0	0	9.1700	Std Pos. Seq.	0.0

3-Winding Transformer Input Data

Transformer ID	Winding	Rating		Tap	Impedance			Z Variation		Phase Shift			
		MVA	kV	%	% Z	X/R	MVA <sub>b</sub>	% Tol.	+5%	-5%	Type	Angle	
3XRI	Primary:	30.000	230.000	-2.50	Z <sub>ps</sub> =	14.40	20.67	30.000	0	0	0		
	Secondary:	10.000	4.360	0	Z <sub>pt</sub> =	11.10	22.80	30.000	0			Std Pos. Seq.	0.0
	Tertiary:	20.000	4.360	0	Z <sub>st</sub> =	24.60	19.16	30.000	0			Std Pos. Seq.	0.0

**AUXILIARY SYSTEM VOLTAGE REGULATION**

ICCN C - 130

CCN No. \_\_\_\_\_

Project: E4C-090 REV.3 ICCN C-130

ETAP

Page: 9

Location: SONGS 2 & 3

5.0.0N

Date: 05-24-2005

Contract:

SN: SCALEDISON

Engineer: W. P. Lennartz

Study Case: 3A14aa

Revision: Base

Filename: E4C090

Config.: 090-3A14aa

ECP 050500255 - 34 ICCN C-130 UNIT 3 TRAIN A

Branch Connections

CKT/Branch		Connected Bus ID		% Impedance, Pos. Seq., 100 MVA Base			
ID	Type	From Bus	To Bus	R	X	Z	Y
3B01X	2W XFMR	3B01XHS	3B01	82.27	559.45	565.47	
3B02X	2W XFMR	3B02XHS	3B02	135.87	720.13	732.84	
3B03X	2W XFMR	3B03XHS	3B03	67.16	733.41	736.48	
3B04X	2W XFMR	3B04XHS	3B04	91.02	604.34	611.16	
3B12X	2W XFMR	3B12XHS	3B12	66.61	738.03	741.03	
3B13X	2W XFMR	3B13XHS	3B13	67.25	737.06	740.12	
3B16X	2W XFMR	3B16XHS	3B16	64.30	562.58	566.24	
B10X-B	2W XFMR	B10XBHS	B10	81.92	550.47	556.53	
3XR1	3W Xfmr	SWITCHYARD-3	3XR1-X	2.05	48.67	48.72	
	3W Xfmr	SWITCHYARD-3	3XR1-Y	1.45	37.16	37.19	
	3W Xfmr	3XR1-X	3XR1-Y	234.80	1143.83	1167.68	
0XB1002P1	Cable	B10	BP	193.61	302.86	359.46	
0XB1014P1	Cable	B10	BO	144.93	226.71	269.08	
0XB1015P1	Cable	B10	ZTB45	1956.57	739.31	2091.59	
0XB1015P2	Cable	ZTB45	D645	393.54	47.26	396.37	
3AA0402P1	Cable	3A04	D007-3A0402	1.38	0.90	1.65	
3AAD409P1	Cable	3A04	3D004-3AD409	8.00	5.21	9.54	
3AA0417P1	Cable	3A04	3B04XHS	2.01	1.31	2.40	
3AB0403P1	Cable	3B04	3BRA	56.47	57.45	80.55	
3AB0407P1	Cable	3B04	3BD	1393.46	1417.64	1987.82	
3AB0414P1	Cable	3B04	3BE	56.47	57.45	80.55	
3AB0415P1	Cable	3B04	3BY	34.30	53.65	63.68	
3AB0417P1	Cable	3B04	BQ	329.69	335.42	470.32	
3AB0418P1	Cable	3B04	DB0415-3B0418	502.91	284.20	577.66	
3ABRA06P1	Cable	3BRA	3L707-3BRA06	6124.39	221.27	6128.39	
3XA0304P1	Cable	3A03	3B13XHS	1.90	1.24	2.27	
3XA0309P1	Cable	3A03	ASC1	6.45	4.19	7.69	
3XA0310P1	Cable	3A03	3B12XHS	1.73	1.12	2.06	
3XA0311P1	Cable	3A03	3B03XHS	1.15	0.75	1.37	
3XA0312P1	Cable	3A03	3PEXCC5	5.05	4.39	6.69	
3XA0801P1	Cable	3A08	B10XBHS	4.89	3.18	5.84	
3XA0802P1	Cable	3A08	3B16XHS	1.73	1.12	2.06	
3XA0808P1	Cable	3A08	3B01XHS	5.84	3.80	6.97	
3XA0809P1	Cable	3A08	3B02XHS	6.68	4.34	7.97	
3XB0102P1	Cable	3B01	3BA	61.96	96.92	115.03	
3XB0205P1	Cable	3B02	3BHP02	182.55	125.70	221.64	
3XB0206P1	Cable	3B02	3BHP03	182.55	125.70	221.64	

AUXILIARY SYSTEM VOLTAGE REGULATION

ICCN C - 130

Project: E4C-090 REV.3 ICCN C-130  
 Location: SONGS 2 & 3  
 Contract:  
 Engineer: W. P. Lennartz  
 Filename: E4C090

ETAP  
 5.0.0N  
 Study Case: 3A14aa

Page: 10  
 Date: 05-24-2005  
 SN: SCALEDISON  
 Revision: Base  
 Config.: 090-3A14aa

ECP 050500255 - 34 ICCN C-130 UNIT 3 TRAIN A

CKT/Branch		Connected Bus ID		% Impedance, Pos. Seq., 100 MVA Base			
ID	Type	From Bus	To Bus	R	X	Z	Y
3XB0210P1,P2	Cable	3B02	3BHP01	347.63	160.70	382.97	
3XB0306P1	Cable	3B03	3BF	347.39	543.42	644.97	
3XB0314P1	Cable	3B03	3BB	778.75	976.15	1248.73	
3XB0402P1	Cable	3B04	3BHP04	488.17	496.64	696.39	
3XB1202P1	Cable	3B12	3BV	200.25	313.24	371.78	
3XB1203P1	Cable	3B12	3BLX	534.77	670.32	857.50	
3XB1211P1	Cable	3B12	3L111	1102.02	1121.14	1572.07	
3XB1303P1	Cable	3B13	3BMX	268.09	336.05	429.89	
3XB1305P1	Cable	3B13	3BC	539.03	675.66	864.33	
3XB1602P1	Cable	3B16	3BX	247.82	387.66	460.11	
3XB1603P1,P2	Cable	3B16	BT-3B1603	337.89	343.75	482.01	
3XB1611P1	Cable	3B16	3B1611BP	673.96	685.66	961.43	
3XXR169P1-P3	Cable	3XR1-X	3A04	2.30	3.42	4.12	
3XXR169P7,P8	Cable	3XR1-Y	3A08	3.34	4.96	5.98	
3XXR169PA-PD,P9	Cable	3XR1-Y	3A03	0.82	1.22	1.47	
3BD18	Tie Breakr	3BD	3BD18-HTRS				
3BD26	Tie Breakr	3BD	3Q020				
3BDM	Tie Breakr	3BD	3BDMM				
3BDS	Tie Breakr	3BD	3BD5M				
3BE51	Tie Breakr	3BE	3T063				
3BEM	Tie Breakr	3BE	3BEMM				
3BES	Tie Breakr	3BE	3BESM				
3BRA22	Tie Breakr	3BRA	3Q074				
3BRAM	Tie Breakr	3BRA	3BRAMM				
3BRAS	Tie Breakr	3BRA	3BRASM				
3BY39	Tie Breakr	3BY	3BY39-HTRS				
3BY40	Tie Breakr	3BY	3BY40-HTRS				
3BY42	Tie Breakr	3BY	3Q039				
3BYM	Tie Breakr	3BY	3BYMM				
3BYS	Tie Breakr	3BY	3BY5M				
BQ27	Tie Breakr	BQ	Q033				
BQM	Tie Breakr	BQ	BQMM				
BQS	Tie Breakr	BQ	BQ5M				
U3-SWYD-CB	Tie Breakr	SWITCHYARD-3	SWITCHYARD				
3D004	Tie Switch	3D004-3P018	3D004-3A0409				
3L707X	Tie Switch	3HV9377-N	3L707-3BRA06				
BT XFRSW	Tie Switch	BT	BT-3B1603				
D007	Tie Switch	D007-E336	D007-3A0402				
DB0415	Tie Switch	DB0415-E418	DB0415-3B0418				

AUXILIARY SYSTEM VOLTAGE REGULATION

ICCN C - 130

CCN No. \_\_\_\_\_

Project: E4C-090 REV.3 ICCN C-130

ETAP

Page: 11

Location: SONGS 2 & 3

5.0.0N

Date: 05-24-2005

Contract:

SN: SCALEDISON

Engineer: W. P. Lennartz

Study Case: 3A14aa

Revision: Base

Filename: E4C090

Config.: 090-3A14aa

ECP 050500255 - 34 ICCN C-130 UNIT 3 TRAIN A

Equipment Cable Input Data

Equipment Cable ID	Equipment ID	Type	Library	Size	Ohms or Siemens/1000 ft per Conductor							O/L Heater	
					Length							Resistance	
					Adj. (ft)	% Tol	#/ph	T (°C)	R	X	Y	Adj. (ohm)	% Tol
0ABQ07P1	2A173	Ind. Motor	0.6MCUN3	12	358.0	0.0	1	75	1.97200	.04560	.0000000	.0000	0.0
0ABQ08P1	2E255	Ind. Motor	0.6MCUN3	10	216.0	0.0	1	75	1.24000	.04480	.0000000	.0000	0.0
0ABQ05P1	2L270	Stat. Load	0.6MCUN3	12	410.0	0.0	1	75	1.97200	.04560	.0000000	.0000	0.0
3XB0310P1,P2	3A001	Ind. Motor	0.6MCUN1	1/0	227.0	0.0	1	75	.13100	.04950	.0000000	.0000	0.0
3AB0409P1-P3	3A071	Ind. Motor	0.6MCUN1	1/0	447.0	0.0	1	75	.13100	.04950	.0000000	.0000	0.0
3AB0419P1-P3	3A074	Ind. Motor	0.6MCUN1	1/0	498.0	0.0	1	75	.13100	.04950	.0000000	.0000	0.0
0ABQ14P1	3A173	Ind. Motor	0.6MCUN3	12	368.0	0.0	1	75	1.97200	.04560	.0000000	.0000	0.0
3ABD12P1	3A274	Ind. Motor	0.6MCUN3	2	58.0	0.0	1	75	.19700	.03440	.0000000	.0000	0.0
3ABD13P1	3A275	Ind. Motor	0.6MCUN3	2	120.0	0.0	1	75	.19700	.03440	.0000000	.0000	0.0
3ABY07P1	3A370	Ind. Motor	0.6MCUN3	12	403.0	0.0	1	75	1.97200	.04560	.0000000	.0000	0.0
3ABY08P1	3A373	Ind. Motor	0.6MCUN3	12	520.0	0.0	1	75	1.97200	.04560	.0000000	.0000	0.0
3ABY36P1	3A394	Ind. Motor	0.6MCUN3	10	628.0	0.0	1	75	1.24000	.04480	.0000000	.0000	0.0
3ABY03P1	3B001	Stat. Load	0.6MCUN1	1/0	122.0	0.0	1	75	.13100	.04950	.0000000	.0000	0.0
3ABE04P1	3B003	Stat. Load	0.6MCUN1	1/0	117.0	0.0	1	75	.13100	.04950	.0000000	.0000	0.0
3XB1609P2	3B005	Stat. Load	0.6MCUN1	3/0	191.0	0.0	1	75	.08600	.04860	.0000000	.0000	0.0
3XB0210P3-P5	3E122-H1	Stat. Load	0.6MCUN3	2	284.0	0.0	1	75	.19700	.03440	.0000000	.0000	0.0
3XB0206P2-P4	3E124-H1	Stat. Load	0.6MCUN3	2	290.0	0.0	1	75	.19700	.03440	.0000000	.0000	0.0
3XB0205P2,P3,PE	3E126-H1	Stat. Load	0.6MCUN3	2	282.0	0.0	1	75	.19700	.03440	.0000000	.0000	0.0
3XB0402P2,P3,P4	3E128-H1 [X]	Stat. Load	0.6MCUN3	2	314.0	0.0	1	75	.19700	.03440	.0000000	.0000	0.0
3XA0803P1	3E202	Ind. Motor	0.6MCUN3	250	142.0	0.0	1	75	.05470	.03560	.0000000	.0000	0.0
0ABQ15P1	3E255	Ind. Motor	0.6MCUN3	10	346.0	0.0	1	75	1.24000	.04480	.0000000	.0000	0.0
3ABY38P1	3E370	Ind. Motor	0.6MCUN3	2	450.0	0.0	1	75	.19700	.03440	.0000000	.0000	0.0
3ABY39P6	3E370H	Stat. Load	0.6MCUN3	12	460.0	0.0	1	75	1.97200	.04560	.0000000	.0000	0.0
3XB0209P1-P3	3E394	Ind. Motor	0.6MCUN1	1/0	308.0	0.0	1	75	.13100	.04950	.0000000	.0000	0.0
3XB0106P1-P3	3E397	Ind. Motor	0.6MCUN1	1/0	213.0	0.0	1	75	.13100	.04950	.0000000	.0000	0.0
3AB0410P1-P3	3E399	Ind. Motor	0.6MCUN1	3/0	315.0	0.0	1	75	.08600	.04860	.0000000	.0000	0.0
3ABY40P6,P7,P8	3E399H	Stat. Load	0.6MCUN3	12	442.0	0.0	1	75	1.97200	.04560	.0000000	.0000	0.0
3AB0411P1-P3	3E401	Ind. Motor	0.6MCUN1	3/0	316.0	0.0	1	75	.08600	.04860	.0000000	.0000	0.0
3ABY40P9,PA,PB	3E401H	Stat. Load	0.6MCUN3	12	366.0	0.0	1	75	1.97200	.04560	.0000000	.0000	0.0
3ABY24P1	3E417	Ind. Motor	0.6MCUN3	10	430.0	0.0	1	75	1.24000	.04480	.0000000	.0000	0.0
3ABY22P1	3E427	Ind. Motor	0.6MCUN3	10	120.0	0.0	1	75	1.24000	.04480	.0000000	.0000	0.0
3ABY20P1	3E437	Ind. Motor	0.6MCUN3	12	370.0	0.0	1	75	1.97200	.04560	.0000000	.0000	0.0
3ABY21P1	3E438	Ind. Motor	0.6MCUN3	12	370.0	0.0	1	75	1.97200	.04560	.0000000	.0000	0.0
3ABY11P1	3E439	Ind. Motor	0.6MCUN3	12	330.0	0.0	1	75	1.97200	.04560	.0000000	.0000	0.0
3ABY12P1	3E440	Ind. Motor	0.6MCUN3	12	330.0	0.0	1	75	1.97200	.04560	.0000000	.0000	0.0
3ABY37P1	3E441	Ind. Motor	0.6MCUN3	12	460.0	0.0	1	75	1.97200	.04560	.0000000	.0000	0.0
3ABY30P1	3E453	Ind. Motor	0.6MCUN3	12	374.0	0.0	1	75	1.97200	.04560	.0000000	.0000	0.0
3ABY31P1	3E454	Ind. Motor	0.6MCUN3	12	309.0	0.0	1	75	1.97200	.04560	.0000000	.0000	0.0
3ABE03P1,P2	3E464	Stat. Load	0.6MCUN3	2	464.0	0.0	1	75	.19700	.03440	.0000000	.0000	0.0
3ABY25P1	3E517	Ind. Motor	0.6MCUN3	12	354.0	0.0	1	75	1.97200	.04560	.0000000	.0000	0.0
3ABD22P1	3E546	Ind. Motor	0.6MCUN3	2	148.0	0.0	1	75	.19700	.03440	.0000000	.0000	0.0
3ABD21P1	3E550	Ind. Motor	0.6MCUN3	2	178.0	0.0	1	75	.19700	.03440	.0000000	.0000	0.0
3ABE49P1,P2	3E652	Stat. Load	0.6MCUN3	12	500.0	0.0	1	75	1.97200	.04560	.0000000	.0000	0.0

AUXILIARY SYSTEM VOLTAGE REGULATION

ICCN C - 130

CCN No. \_\_\_\_\_

Project: E4C-090 REV.3 ICCN C-130  
 Location: SONGS 2 & 3  
 Contract:  
 Engineer: W. P. Lennartz  
 Filename: E4C090

ETAP  
 5.0.0N  
 Study Case: 3A14aa

Page: 12  
 Date: 05-24-2005  
 SN: SCALEDISON  
 Revision: Base  
 Config.: 090-3A14aa

ECP 050500255 - 34 ICCN C-130 UNIT 3 TRAIN A

Equipment Cable		Equipment		Ohms or Siemens/1000 ft per Conductor									O/L Header	
ID	ID	Type	Library	Size	Length				R	X	Y	Resistance		
					Adj. (ft)	% Tol	#/ft	T (°C)				Adj.(ohms)	% Tol	
3ABE36P1	311V4731	Ind. Motor	0.6MCUN3	12	562.0	0.0	1	75	1.97200	.04560	.0000000	.0000	0.0	
3XB1606P1.P2	3L046	Ind. Motor	0.6MCUN1	250	416.0	0.0	2	75	.06080	.04800	.0000000	.0000	0.0	
3ABE42P1	3L266	Stat. Load	0.6MCUN3	6	360.0	0.0	1	75	.49300	.03910	.0000000	.0000	0.0	
0ABQ06P1	3L270	Stat. Load	0.6MCUN3	12	650.0	0.0	1	75	1.97200	.04560	.0000000	.0000	0.0	
3XBY23P1	3L411(X)	Stat. Load	0.6MCUN3	12	177.0	0.0	1	75	1.97200	.04560	.0000000	.0000	0.0	
3ABY34P1	3P009	Ind. Motor	0.6MCUN3	2	470.0	0.0	1	75	.19700	.03440	.0000000	.0000	0.0	
3AA0403P1	3P012	Ind. Motor	8.0MCUN3	250	332.0	0.0	1	75	.05470	.03560	.0000000	.0000	0.0	
3ABY40P1	3P012H	Stat. Load	0.6MCUN3	12	372.0	0.0	1	75	1.97200	.04560	.0000000	.0000	0.0	
3AA0407P1	3P015	Ind. Motor	8.0MCUN3	250	338.0	0.0	1	75	.05470	.03560	.0000000	.0000	0.0	
3ABY39P1	3P015H	Stat. Load	0.6MCUN3	12	369.0	0.0	1	75	1.97200	.04560	.0000000	.0000	0.0	
3AA0408P1	3P017	Ind. Motor	8.0MCUN3	250	364.0	0.0	1	75	.05470	.03560	.0000000	.0000	0.0	
3ABY39P2	3P017H	Stat. Load	0.6MCUN3	12	548.0	0.0	1	75	1.97200	.04560	.0000000	.0000	0.0	
3WAD004P1	3P018	Ind. Motor	8.0MCUN3	250	36.0	0.0	1	75	.05470	.03560	.0000000	.0000	0.0	
3ABY39P3	3P018HA	Stat. Load	0.6MCUN3	12	400.0	0.0	1	75	1.97200	.04560	.0000000	.0000	0.0	
3AA0405P1	3P024	Ind. Motor	8.0MCUN3	250	328.0	0.0	1	75	.05470	.03560	.0000000	.0000	0.0	
3XA0308P1	3P050	Ind. Motor	8.0MCUN3	750	73.0	0.0	1	75	.02080	.03090	.0000000	.0000	0.0	
3XA0307P1	3P051	Ind. Motor	8.0MCUN3	750	107.0	0.0	1	75	.02080	.03090	.0000000	.0000	0.0	
3XA0312P2	3P058	Ind. Motor	5.0MCUS1	350	36.0	0.0	1	75	.04610	.05140	.0000000	.0000	0.0	
3XB0303P1	3P075	Ind. Motor	0.6MCUN1	170	166.0	0.0	1	75	.13100	.04950	.0000000	.0000	0.0	
3ABD23P1	3P093	Ind. Motor	0.6MCUN3	12	170.0	0.0	1	75	1.97200	.04560	.0000000	.0000	0.0	
3ABD24P1	3P096	Ind. Motor	0.6MCUN3	12	170.0	0.0	1	75	1.97200	.04560	.0000000	.0000	0.0	
3ABY10P1	3P101B	Ind. Motor	0.6MCUN3	10	370.0	0.0	1	75	1.24000	.04480	.0000000	.0000	0.0	
3ABY39P9	3P1018H	Stat. Load	0.6MCUN3	12	370.0	0.0	1	75	1.97200	.04560	.0000000	.0000	0.0	
3ABY39P4	3P112H	Stat. Load	0.6MCUN3	12	482.0	0.0	1	75	1.97200	.04560	.0000000	.0000	0.0	
3XA0306P1	3P115	Ind. Motor	8.0MCUN3	500	308.0	0.0	1	75	.02920	.03340	.0000000	.0000	0.0	
3XA0305P1	3P117	Ind. Motor	8.0MCUN3	500	340.0	0.0	1	75	.02920	.03340	.0000000	.0000	0.0	
3XA0313P1	3P120	Ind. Motor	8.0MCUN3	250	678.0	0.0	1	75	.05470	.03560	.0000000	.0000	0.0	
3XB1206P1-P3	3P127	Ind. Motor	0.6MCUN1	500	563.0	0.0	1	75	.03590	.04500	.0000000	.0000	0.0	
3XB0110P1	3P12B	Ind. Motor	0.6MCUN1	270	314.0	0.0	1	75	.10600	.04500	.0000000	.0000	0.0	
3XB1306P1	3P135	Ind. Motor	0.6MCUN1	470	701.0	0.0	1	75	.07000	.04820	.0000000	.0000	0.0	
3AA0404P1	3P141	Ind. Motor	8.0MCUN3	250	540.0	0.0	1	75	.05470	.03560	.0000000	.0000	0.0	
3ABY39P8	3P141H	Stat. Load	0.6MCUN3	12	779.0	0.0	1	75	1.97200	.04560	.0000000	.0000	0.0	
3ABY14P1	3P174	Ind. Motor	0.6MCUN3	6	330.0	0.0	1	75	.49300	.03910	.0000000	.0000	0.0	
3ABY40P2	3P174H	Stat. Load	0.6MCUN3	12	420.0	0.0	1	75	1.97200	.04560	.0000000	.0000	0.0	
3ABY15P1	3P175	Ind. Motor	0.6MCUN3	6	330.0	0.0	1	75	.49300	.03910	.0000000	.0000	0.0	
3ABY40P3	3P175H	Stat. Load	0.6MCUN3	12	300.0	0.0	1	75	1.97200	.04560	.0000000	.0000	0.0	
3AB0413P1	3P190	Ind. Motor	0.6MCUN1	370	316.0	0.0	1	75	.08600	.04860	.0000000	.0000	0.0	
3ABY40P4	3P190H	Stat. Load	0.6MCUN3	12	420.0	0.0	1	75	1.97200	.04560	.0000000	.0000	0.0	
3ABY40P5	3P191HA	Stat. Load	0.6MCUN3	12	336.0	0.0	1	75	1.97200	.04560	.0000000	.0000	0.0	
3XB0309P1	3P290	Ind. Motor	0.6MCUN1	170	198.0	0.0	1	75	.13100	.04950	.0000000	.0000	0.0	
3AA0411P1	3P307	Ind. Motor	8.0MCUN3	250	430.0	0.0	1	75	.05470	.03560	.0000000	.0000	0.0	
3ABY39P5	3P307H	Stat. Load	0.6MCUN3	12	466.0	0.0	1	75	1.97200	.04560	.0000000	.0000	0.0	
3ABD10P1	3P996/3P1015	Ind. Motor	0.6MCUN3	12	106.0	0.0	1	75	1.97200	.04560	.0000000	.0000	0.0	
3ABD11P1	3P997/3P1014	Ind. Motor	0.6MCUN3	12	60.0	0.0	1	75	1.97200	.04560	.0000000	.0000	0.0	
3ABE41P1	3RU7834-1	Stat. Load	0.6MCUN3	12	230.0	0.0	1	75	1.97200	.04560	.0000000	.0000	0.0	
3ABE02P1	3RU7822-1	Stat. Load	0.6MCUN3	12	500.0	0.0	1	75	1.97200	.04560	.0000000	.0000	0.0	
3XB1210P1	3T011	Stat. Load	0.6MCUN1	350	294.0	0.0	1	75	.04610	.04690	.0000000	.0000	0.0	

AUXILIARY SYSTEM VOLTAGE REGULATION

ICCN C - 130

CCN No. \_\_\_\_\_

Project: E4C-090 REV.3 ICCN C - 130

ETAP

Page: 13

Location: SONGS 2 & 3

5.0.0N

Date: 05-24-2005

Contract:

SN: SCALEDISON

Engineer: W. P. Lennartz

Study Case: 3A14aa

Revision: Base

Filename: E4C090

Config.: 090-3A14aa

ECP 050500255 - 34 ICCN C - 130 UNIT 3 TRAIN A

Equipment Cable	Equipment	Type	Library	Size	Ohms or Siemens/1000 ft per Conductor							O/L Heater	
					Length				Resistance			Resistance	
					Adj. (ft)	% Tol	#/ph	T (°C)	R	X	Y	Adj.(ohm)	% Tol
3XA0412P1	3T014[X]	Stat. Load	8.0MCUN3	250	462.0	0.0	1	75	.05470	.03560	.0000000	.0000	0.0
3XBY33P2,P3	3T110/3Q071[X]	Stat. Load	0.6MCUN1	2	949.0	0.0	1	75	.20300	.05130	.0000000	.0000	0.0
0ABQ22P1	A053	Ind. Motor	0.6MCUN3	12	472.0	0.0	1	75	1.97200	.04560	.0000000	.0000	0.0
0ABQ23P1	A056	Ind. Motor	0.6MCUN3	12	472.0	0.0	1	75	1.97200	.04560	.0000000	.0000	0.0
0ABQ09P2	A207	Ind. Motor	0.6MCUN3	10	640.0	0.0	1	75	1.24000	.04480	.0000000	.0000	0.0
0XAC101P2	C443	Ind. Motor	8.0MCUN1	250	90.0	0.0	1	75	.06090	.05250	.0000000	.0000	0.0
0ABQ04P1,P2	E297	Stat. Load	0.6MCUN3	12	518.0	0.0	1	75	1.97200	.04560	.0000000	.0000	0.0
0AAD007P1	E336	Ind. Motor	8.0MCUN3	250	216.0	0.0	1	75	.05470	.03560	.0000000	.0000	0.0
0ABD415P1	E418	Ind. Motor	0.6MCUN1	3/0	415.0	0.0	1	75	.08600	.04860	.0000000	.0000	0.0
0XB1011P1	E643	Stat. Load	0.6MCUN1	500	188.0	0.0	1	75	.03590	.04500	.0000000	.0000	0.0
0XB1015P3	E645	Stat. Load	0.6MCUN3	10	10.0	0.0	1	75	1.24000	.04480	.0000000	.0000	0.0
0ABQ13P1	L211-1	Stat. Load	0.6MCUN3	6	90.0	0.0	1	75	.49300	.03910	.0000000	.0000	0.0
0ABQ26P1	L211-4	Stat. Load	0.6MCUN3	6	120.0	0.0	1	75	.49300	.03910	.0000000	.0000	0.0
0XBQ11P1	L437[X]	Stat. Load	0.6MCUN3	10	300.0	0.0	1	75	1.24000	.04480	.0000000	.0000	0.0
3XBY19P1	LP35A[X]	Stat. Load	0.6MCUN3	6	339.0	0.0	1	75	.49300	.03910	.0000000	.0000	0.0
3XB1307P1	N002	Stat. Load	0.6MCUN1	1/0	824.0	0.0	1	75	.13100	.04950	.0000000	.0000	0.0
0XB1006P1	P159	Ind. Motor	0.6MCUN1	1/0	402.0	0.0	1	75	.13100	.04950	.0000000	.0000	0.0
0ABQ24P1	P162	Ind. Motor	0.6MCUN3	2	468.0	0.0	1	75	.19700	.03440	.0000000	.0000	0.0
0ABQ20P1	P445	Ind. Motor	0.6MCUN3	12	584.0	0.0	1	75	1.97200	.04560	.0000000	.0000	0.0
0ABQ25P1	W310	Ind. Motor	0.6MCUN3	12	584.0	0.0	1	75	1.97200	.04560	.0000000	.0000	0.0



AUXILIARY SYSTEM VOLTAGE REGULATION

ICCN C - 130

CCN No. \_\_\_\_\_

Project: E4C-090 REV.3 ICCN C-130

ETAP

Page: 14

Location: SONGS 2 & 3

5.0.0N

Date: 05-24-2005

Contract:

SN: SCALEDISON

Engineer: W. P. Lennartz

Study Case: 3A14aa

Revision: Base

Filename: E4C090

Config.: 090-3A14aa

ECP 050500255 - 34 ICCN C-130 UNIT 3 TRAIN A

LOAD FLOW REPORT

Bus		Voltage		Generation		Load		Load Flow					XFMR
ID	kV	kV	Ang.	MW	Mvar	MW	Mvar	ID	MW	Mvar	Amp	% PF	% Tap
3A03	4.160	4.017	-4.1	0	0	10.000	5.865	3B13XHS	0.384	0.185	61.2	90.1	
								ASCI	0.232	0.115	37.3	89.5	
								3B12XHS	0.761	0.451	127.1	86.0	
								3B03XHS	0.608	0.365	102.0	85.7	
								3PEXCC3	1.773	0.909	286.4	89.0	
								3XR1-Y	-13.758	-7.891	2279.8	86.7	
3A04	4.160	4.139	-1.6	0	0	2.722	1.372	D007-3A0402	0.456	0.256	72.9	87.2	
								3D004-3A0409	0.408	0.174	61.8	92.0	
								3B04XHS	1.188	0.761	196.8	84.2	
								3XR1-X	-4.774	-2.562	755.8	88.1	
3A08	4.160	4.017	-4.1	0	0	0.796	0.339	B10XB11S	0.703	0.258	107.7	93.9	
								3B16XHS	0.971	0.661	168.8	82.7	
								3B01XHS	0.396	0.232	65.9	86.3	
								3B02XHS	0.575	0.062	83.1	99.4	
								3XRJ-Y	-3.441	-1.552	542.5	91.2	
3B01	0.480	0.443	-5.5	0	0	0.131	0.078	3BA	0.263	0.140	388.1	88.2	
								3B01XHS	-0.394	-0.218	585.7	87.5	
3B01XHS	4.160	4.016	-4.1	0	0	0	0	3A08	-0.396	-0.232	65.9	86.3	
								3B01	0.396	0.232	65.9	86.3	2.500
3B02	0.480	0.457	-6.9	0	0	0.049	0.031	3BHP02	0.190	0.001	239.4	100.0	
								3BHP03	0.190	0.001	239.4	100.0	
								3BHP01	0.141	0.000	178.6	100.0	
								3B02XHS	-0.569	-0.033	720.2	99.8	
								3A08	-0.575	-0.062	83.1	99.4	
3B02XHS	4.160	4.015	-4.1	0	0	0	0	3A08	-0.575	-0.062	83.1	99.4	
3B03	0.480	0.447	-7.1	0	0	0.206	0.120	3BF	0.238	0.107	336.3	91.2	
								3BB	0.160	0.095	240.9	85.9	
3B03XHS	4.160	4.016	-4.1	0	0	0	0	3B03XHS	-0.604	-0.322	884.0	88.3	
								3A03	-0.608	-0.365	102.0	85.7	
								3B03	0.608	0.365	102.0	85.7	
3B04	0.480	0.449	-6.0	0	0	0.261	0.172	3BRA	0.014	0.008	20.5	84.9	
								3BD	0.147	0.101	230.0	82.3	
								3BE	0.101	0.055	148.3	87.8	
								3BY	0.224	0.139	339.6	85.1	
								BQ	0.127	0.077	191.1	85.5	
								DB0415-3B0418	0.112	0.072	171.5	84.1	

AUXILIARY SYSTEM VOLTAGE REGULATION

ICCN C - 130

CCN No. \_\_\_\_\_

Project: E4C-090 REV.3 ICCN C - 130

ETAP

Page: 15

Location: SONGS 2 & 3

5.0.0N

Date: 05-24-2005

Contract:

SN: SCALEDISON

Engineer: W. P. Lennartz

Study Case: 3A14aa

Revision: Base

Filename: E4C090

Config.: 090-3A14aa

ECP 050500255 - 34 ICCN C - 130 UNIT 3 TRAIN A

Bus		Voltage		Generation		Load		Load Flow				XFMR	
ID	kV	kV	Ang.	MW	Mvar	MW	Mvar	ID	MW	Mvar	Amp	% PF	% Tap
								3BHP04	0.181	0.002	233.2	100.0	
								3BD4XHS	-1.168	-0.627	1705.9	88.1	
3B04XHS	4.160	4.137	-1.6	0	0	0	0	3A04	-1.183	-0.760	196.8	84.2	
								3B04	1.188	0.760	196.8	84.2	
3B12	0.480	0.443	-7.9	0	0	0.322	0.158	3BV	0.202	0.124	309.0	85.2	
								3BLX	0.031	0.027	75.7	88.4	
								3L111	0.179	0.073	251.7	92.6	
								3B12XHS	-0.754	-0.383	1101.6	89.2	
3B12XHS	4.160	4.016	-4.1	0	0	0	0	3A03	-0.761	-0.451	127.1	86.0	
								3B12	0.761	0.451	127.1	86.0	
3B13	0.480	0.455	-6.0	0	0	0.225	0.080	3BMX	0.051	0.026	72.9	89.1	
								3BC	0.106	0.063	156.8	86.0	
								3B13XHS	-0.382	-0.169	530.6	91.4	
3B13XHS	4.160	4.016	-4.1	0	0	0	0	3A03	-0.384	-0.185	61.2	90.1	
								3B13	0.384	0.185	61.2	90.1	
3B16	0.480	0.441	-7.7	0	0	0.160	0.109	3BX	0.304	0.143	440.2	90.5	
								BT-3B1603	0.373	0.210	560.6	87.2	
								3B1611BP	0.124	0.108	215.0	75.5	
								3B16XHS	-0.961	-0.569	1463.3	86.0	
3B16XHS	4.160	4.016	-4.1	0	0	0	0	3A08	-0.571	-0.661	168.8	82.7	
								3B16	0.971	0.661	168.8	82.7	
3B1611BP	0.480	0.432	-7.8	0	0	0.121	0.105	3B16	-0.121	-0.105	215.0	75.6	
3BA	0.480	0.442	-5.7	0	0	0.262	0.139	3B01	-0.262	-0.139	388.1	88.4	
3BB	0.480	0.435	-7.7	0	0	0.157	0.091	3B03	-0.157	-0.091	240.9	86.5	
3BC	0.480	0.449	-6.2	0	0	0.105	0.062	3B13	-0.105	-0.062	156.8	86.2	
3BD	0.480	0.429	-6.5	0	0	0.130	0.088	3B04	-0.142	-0.096	230.0	82.8	
								3BD18-HTRS	0.000	0.000	0.0	0.0	
								3QC20	0.003	0.002	5.4	85.0	
								3BDMM	0.005	0.003	7.4	83.0	
								3BDSM	0.003	0.002	5.4	85.0	
3BD18-HTRS	0.480	0.429	-6.5	0	0	0	0	3BD	0.000	0.000	0.0	0.0	
3BDMM	0.460	0.429	-6.5	0	0	0.005	0.003	3BD	-0.005	-0.003	7.4	83.0	
3BDSM	0.480	0.429	-6.5	0	0	0.003	0.002	3BD	-0.003	-0.002	5.4	85.0	
3BE	0.480	0.443	-6.0	0	0	0.074	0.038	3B04	-0.101	-0.055	148.3	87.9	
								3T063	0.019	0.011	28.1	85.0	
								3BEMM	0.005	0.003	7.1	83.0	
								3BESM	0.004	0.002	5.6	85.0	
3BEMM	0.460	0.448	-6.0	0	0	0.005	0.003	3BE	-0.005	-0.003	7.1	83.0	

AUXILIARY SYSTEM VOLTAGE REGULATION

ICCN C - 130

CCN No. \_\_\_\_\_

Project: E4C-090 REV.3 ICCN C-130

ETAP

Page: 16

Location: SONGS 2 & 3

5.0.0N

Date: 05-24-2005

Contract:

SN: SCALEDISON

Engineer: W. P. Lennartz

Study Case: 3A14aa

Revision: Base

Filename: E4C090

Config.: 090-3A14aa

ECP 050500255 - 34 ICCN C-130 UNIT 3 TRAIN A

Bus		Voltage			Generation		Load		Load Flow				XFMR	
ID	kV	kV	Ang.	MW	Mvar	MW	Mvar	ID	MW	Mvar	Amp	% PF	% Tap	
3BESM	0.480	0.448	-6.0	0	0	0.004	0.002	3BE	-0.004	-0.002	5.6	85.0		
3BF	0.480	0.439	-7.7	0	0	0.235	0.102	3B03	-0.235	-0.102	336.3	91.7		
3BHP01	0.480	0.454	-7.1	0	0	0.141	0.000	3B02	-0.141	0.000	178.6	100.0		
3BHP02	0.480	0.455	-7.1	0	0	0.189	0.000	3B02	-0.189	0.000	239.4	100.0		
3BHP03	0.480	0.455	-7.1	0	0	0.189	0.000	3B02	-0.189	0.000	239.4	100.0		
3BHP04	0.480	0.444	-6.7	0	0	0.179	0.000	3B04	-0.179	0.000	233.2	100.0		
3BLX	0.480	0.441	-8.0	0	0	0.051	0.027	3B12	-0.051	-0.027	75.7	88.6		
3BMX	0.480	0.454	-6.0	0	0	0.051	0.026	3B13	-0.051	-0.026	72.9	89.1		
3BRA	0.480	0.449	-6.0	0	0	0	0	3B04	-0.014	-0.008	20.5	84.9		
								3L707-3BRA06	0.002	0.001	2.2	90.0		
								3Q074	0.004	0.002	5.6	85.0		
								3BRAMM	0.005	0.003	7.1	83.0		
								3BRASM	0.004	0.002	5.6	85.0		
3BRAMM	0.460	0.449	-6.0	0	0	0.005	0.003	3BRA	-0.005	-0.003	7.1	83.0		
3BRASM	0.480	0.449	-6.0	0	0	0.004	0.002	3BRA	-0.004	-0.002	5.6	85.0		
3BV	0.480	0.439	-8.1	0	0	0.201	0.122	3B12	-0.201	-0.122	309.0	85.5		
3BX	0.480	0.433	-8.3	0	0	0.300	0.137	3B16	-0.300	-0.137	440.2	91.0		
3BY	0.480	0.448	-6.1	0	0	0.192	0.124	3B04	-0.224	-0.138	339.6	85.1		
								3BY39-HTRS	0.007	0.000	8.8	100.0		
								3BY40-HTRS	0.003	0.000	3.3	100.0		
								3Q039	0.015	0.009	22.4	85.0		
								3BYMM	0.005	0.003	7.1	83.0		
								3BYSM	0.004	0.002	5.6	85.0		
3BY39-HTRS	0.480	0.448	-6.1	0	0	0.007	0.000	3BY	-0.007	0.000	8.8	100.0		
3BY40-HTRS	0.480	0.448	-6.1	0	0	0.003	0.000	3BY	-0.003	0.000	3.3	100.0		
3BYMM	0.460	0.448	-6.1	0	0	0.005	0.003	3BY	-0.005	-0.003	7.1	83.0		
3BYSM	0.480	0.448	-6.1	0	0	0.004	0.002	3BY	-0.004	-0.002	5.6	85.0		
3D004-3A0409	4.160	4.137	-1.6	0	0	0	0	3A04	-0.408	-0.174	61.8	92.0		
								3D004-3P018	0.408	0.174	61.8	92.0		
3D004-3P018	4.160	4.137	-1.6	0	0	0.408	0.174	3D004-3A0409	-0.408	-0.174	61.8	92.0		
3HV9377-N	0.480	0.448	-6.0	0	0	0.002	0.001	3L707-3BRA06	-0.002	-0.001	2.2	90.0		
3L111	0.480	0.427	-8.8	0	0	0.174	0.068	3B12	-0.174	-0.068	251.7	93.2		
3L707-3BRA06	0.480	0.448	-6.0	0	0	0	0	3BRA	-0.002	-0.001	2.2	90.0		
								3HV9377-N	0.002	0.001	2.2	90.0		
3PEXCCS	4.160	4.010	-4.1	0	0	1.770	0.907	3A03	-1.770	-0.907	286.4	89.0		
3Q020	0.480	0.429	-6.5	0	0	0.003	0.002	3BD	-0.003	-0.002	5.4	85.0		
3Q039	0.480	0.448	-6.1	0	0	0.015	0.009	3BY	-0.015	-0.009	22.4	85.0		
3Q074	0.480	0.449	-6.0	0	0	0.004	0.002	3BRA	-0.004	-0.002	5.6	85.0		

AUXILIARY SYSTEM VOLTAGE REGULATION

ICCN C - 130

CCN No. \_\_\_\_\_

Project: E4C-090 REV.3 ICCN C-130

ETAP

Page: 17

Location: SONGS 2 & 3

5.00N

Date: 05-24-2005

Contract:

SN: SCALEDISON

Engineer: W. P. Lennartz

Study Case: 3A14aa

Revision: Base

Filename: E4C090

Config.: 090-3A14aa

ECP 050500255 - 34 ICCN C - 130 UNIT 3 TRAIN A

Bus		Voltage		Generation		Load		Load Flow				XFMR	
ID	kV	kV	Ang.	MW	Mvar	MW	Mvar	ID	MW	Mvar	Amp	% PF	% Tap
3TD63	0.480	0.448	-6.0	0	0	0.019	0.011	3BE	-0.019	-0.011	28.1	85.0	
3XR1-X	4.160	4.148	-1.6	0	0	0	0	3A04	4.782	2.573	755.8	88.1	
								3XR1-Y	-4.782	-2.573	755.8	88.1	
								& SWITCHYARD-3					
3XR1-Y	4.160	4.026	-4.0	0	0	0	0	3A08	3.447	1.560	542.5	91.1	
								3A03	13.782	7.927	2279.8	86.7	
								SWITCHYARD-3	-17.229	-9.487	2820.2	87.6	
								& 3XR1-X					
ASCI	4.160	4.016	-4.1	0	0	0.232	0.115	3A03	-0.232	-0.115	37.3	89.5	
B10	0.480	0.453	-6.7	0	0	0.143	0.041	BP	0.273	0.147	395.5	88.1	
								BO	0.273	0.034	351.3	99.2	
								ZTB45	0.008	0.000	10.2	100.0	
								B10XBHS	-0.698	-0.221	933.1	95.3	
B10XBHS	4.160	4.015	-4.1	0	0	0	0	3A08	-0.703	-0.258	107.7	93.9	
								B10	0.703	0.258	107.7	93.9	
BO	0.480	0.450	-7.1	0	0	0.272	0.032	B10	-0.272	-0.032	351.3	99.3	
BP	0.480	0.447	-7.0	0	0	0.271	0.143	B10	-0.271	-0.143	395.5	88.5	
BQ	0.480	0.445	-6.2	0	0	0.107	0.064	3B04	-0.126	-0.076	191.1	85.6	
								Q033	0.011	0.007	16.7	85.0	
								BQMM	0.005	0.003	7.1	83.0	
								BQSM	0.004	0.002	5.6	85.0	
BQMM	0.460	0.445	-6.2	0	0	0.005	0.003	BQ	-0.005	-0.003	7.1	83.0	
BQSM	0.480	0.445	-6.2	0	0	0.004	0.002	BQ	-0.004	-0.002	5.6	85.0	
BT	0.480	0.429	-8.1	0	0	0.365	0.201	BT-3B1603	-0.365	-0.201	560.6	87.6	
BT-3B1603	0.480	0.429	-8.1	0	0	0	0	3B16	-0.365	-0.201	560.6	87.6	
								BT	0.365	0.201	560.6	87.6	
D007-3A0402	4.160	4.138	-1.6	0	0	0	0	3A04	-0.456	-0.256	72.9	87.2	
								D007-E336	0.456	0.256	72.9	87.2	
D007-E336	4.160	4.138	-1.6	0	0	0.456	0.256	D007-3A0402	-0.456	-0.256	72.9	87.2	
D645	0.480	0.452	-6.7	0	0	0.008	0.000	ZTB45	-0.008	0.000	10.2	100.0	
DB0415-3B0418	0.480	0.444	-6.0	0	0	0	0	3B04	-0.111	-0.071	171.5	84.1	
								DB0415-E418	0.111	0.071	171.5	84.1	
DB0415-E418	0.480	0.444	-6.0	0	0	0.111	0.071	DB0415-3B0418	-0.111	-0.071	171.5	84.1	
Q033	0.480	0.445	-6.2	0	0	0.011	0.007	BQ	-0.011	-0.007	16.7	85.0	
* SWITCHYARD	230.000	216.890	0.0	22.088	13.930	0	0	SWITCHYARD-3	22.088	13.930	69.5	84.6	
SWITCHYARD-3	230.000	216.890	0.0	0	0	0	0	SWITCHYARD	-22.088	-13.930	69.5	84.6	
								3XR1-X	22.088	13.930	69.5	84.6	-2.500
								& 3XR1-Y					

AUXILIARY SYSTEM VOLTAGE REGULATION

ICCN C - 130

CCN No. \_\_\_\_\_

Project: E4C-090 REV.3 ICCN C-130

ETAP

Page: 18

Location: SONGS 2 & 3

5.0.0N

Date: 05-24-2005

Contract:

SN: SCALEDISON

Engineer: W. P. Lennartz

Study Case: 3A14aa

Revision: Base

Filename: E4C090

Config.: 090-3A14aa

ECP 050500255 - 34 ICCN C - 130 UNIT 3 TRAIN A

Bus		Voltage			Generation		Load		Load Flow				XFMR	
ID	KV	kV	Ang.	MW	Mvar	MW	Mvar	ID	MW	Mvar	Amp	% PF	% Tap	
ZTB45	0.480	0.452	-6.7	0	0	0	0	B10	-0.003	0.000	10.2	100.0		
								D645	0.003	0.000	10.2	100.0		

\* Indicates a voltage regulated bus (voltage controlled or swing type machine connected to it)

# Indicates a bus with a load mismatch of more than 0.1 MVA

AUXILIARY SYSTEM VOLTAGE REGULATION

ICCN C - 130

CCN No. \_\_\_\_\_

Project: E4C-090 REV.3 ICCN C-130  
 Location: SONGS 2 & 3  
 Contract:  
 Engineer: W. P. Lennartz  
 Filename: E4C090

ETAP  
 5.0.0N  
 Study Case: 3A14aa

Page: 19  
 Date: 05-24-2005  
 SN: SCALEDISON  
 Revision: Base  
 Config.: 090-3A14aa

ECP 050500255 - 34 ICCN C - 130 UNIT 3 TRAIN A

Bus Loading Summary Report

Bus	Directly Connected Load										Total Bus Load				
	ID	kV	Rated Amp	Constant kVA		Constant Z		Constant I		Generic		MVA	% PF	Amp	Percent Loading
				MW	Mvar	MW	Mvar	MW	Mvar	MW	Mvar				
2G002-BUS	4.160			0	0	0	0	0	0	0	0	0	0.0	0.0	
2G003-BUS	4.160			0	0	0	0	0	0	0	0	0	0.0	0.0	
3G002-BUS	4.160			0	0	0	0	0	0	0	0	0	0.0	0.0	
3G003-BUS	4.160			0	0	0	0	0	0	0	0	0	0.0	0.0	
3A03	4.160	3000.0	10.000	5.865	0.0	0.0	0.0	0.0	0.0	0.0	15.860	86.7	2279.8	76.0	
3A04	4.160	3000.0	2.596	1.294	0.126	0.078	0	0	0	0	5.418	88.1	755.8	25.2	
3A08	4.160	1200.0	0.796	0.339	0	0	0	0	0	0	3.775	91.2	542.5	45.2	
3B01	0.480	2000.0	0.131	0.078	0	0	0	0	0	0	0.450	87.5	585.7	29.3	
3B01XHS	4.160		0	0	0	0	0	0	0	0	0.439	86.3	65.9		
3B02	0.480	1600.0	0.049	0.031	0	0	0	0	0	0	0.570	99.8	720.2	45.0	
3B02XHS	4.160		0	0	0	0	0	0	0	0	0.578	99.4	83.1		
3B03	0.480	1600.0	0.206	0.120	0	0	0	0	0	0	0.685	88.3	884.0	55.2	
3B03XHS	4.160		0	0	0	0	0	0	0	0	0.709	85.7	102.0		
3B04	0.480	2000.0	0.261	0.172	0	0	0	0	0	0	1.325	88.1	1705.9	85.3	
3B04XHS	4.160		0	0	0	0	0	0	0	0	1.410	84.2	196.8		
3B12	0.480	1600.0	0.202	0.118	0.120	0.040	0	0	0	0	0.846	89.2	1101.6	68.8	
3B12XHS	4.160		0	0	0	0	0	0	0	0	0.884	86.0	127.1		
3B13	0.480	1600.0	0.152	0.079	0.073	0.001	0	0	0	0	0.418	91.4	530.6	33.2	
3B13XHS	4.160		0	0	0	0	0	0	0	0	0.426	90.1	61.2		
3B16	0.480	2000.0	0.089	0.043	0.071	0.066	0	0	0	0	1.117	86.0	1463.3	73.2	
3B16XHS	4.160		0	0	0	0	0	0	0	0	1.175	82.7	168.8		
3B1611BP	0.480	800.0	0.006	0.004	0.116	0.101	0	0	0	0	0.161	75.6	215.0	26.9	
3BA	0.480	600.0	0.153	0.097	0.109	0.042	0	0	0	0	0.297	88.4	388.1	64.7	
3BB	0.480	600.0	0.138	0.087	0.019	0.005	0	0	0	0	0.181	86.5	240.9	40.2	
3BC	0.480	600.0	0.041	0.030	0.064	0.032	0	0	0	0	0.122	86.2	156.8	26.1	
3BD	0.480	600.0	0.130	0.088	0	0	0	0	0	0	0.171	82.8	230.0	38.3	
3BD18-HTRS	0.480		0	0	0	0	0	0	0	0	0	0.0	0.0	0.0	
3BDMM	0.460		0.005	0.003	0	0	0	0	0	0	0.006	83.0	7.4		
3BDSM	0.480		0	0	0.003	0.002	0	0	0	0	0.004	85.0	5.4		
3BE	0.480	600.0	0.001	0.001	0.073	0.037	0	0	0	0	0.115	87.9	148.3	24.7	
3BEMM	0.460		0.005	0.003	0	0	0	0	0	0	0.006	83.0	7.1		
3BESM	0.480		0	0	0.004	0.002	0	0	0	0	0.004	85.0	5.6		
3BF	0.480	600.0	0.104	0.052	0.131	0.050	0	0	0	0	0.256	91.7	336.3	56.1	
3BHP01	0.480		0	0	0.141	0	0	0	0	0	0.141	100.0	178.6		
3BHP02	0.480		0	0	0.189	0	0	0	0	0	0.189	100.0	239.4		
3BHP03	0.480		0	0	0.189	0	0	0	0	0	0.189	100.0	239.4		

AUXILIARY SYSTEM VOLTAGE REGULATION

ICCN C - 130

CCN No. \_\_\_\_\_

Project: E4C-090 REV.3 ICCN C-130

ETAP

Page: 20

Location: SONGS 2 & 3

5.0.0N

Date: 05-24-2005

Contract:

SN: SCALEDISON

Engineer: W. P. Lennartz

Study Case: 3A14aa

Revision: Base

Filename: E4C090

Config.: 090-3A14aa

ECP 050500255 - 34 ICCN C-130 UNIT 3 TRAIN A

Bus			Directly Connected Load								Total Bus Load			Percent Loading
ID	kV	Rated Amp	Constant kVA		Constant Z		Constant I		Generic		MVA	% PF	Amp	
			MW	Mvar	MW	Mvar	MW	Mvar	MW	Mvar				
3BHP04	0.480		0	0	0.179	0	0	0	0	0	0.179	100.0	233.2	
3BLX	0.480	600.0	0.036	0.023	0.015	0.004	0	0	0	0	0.058	88.6	75.7	12.6
3BMX	0.480	600.0	0.035	0.022	0.016	0.004	0	0	0	0	0.057	89.1	72.9	12.1
3BRA	0.480	600.0	0	0	0	0	0	0	0	0	0.016	84.9	20.5	3.4
3BRAMM	0.460		0.005	0.003	0	0	0	0	0	0	0.006	83.0	7.1	
3BRASM	0.480		0	0	0.004	0.002	0	0	0	0	0.004	85.0	5.6	
3BV	0.480	600.0	0.101	0.073	0.100	0.049	0	0	0	0	0.235	85.5	309.0	51.5
3BX	0.480	600.0	0.107	0.070	0.194	0.067	0	0	0	0	0.330	91.0	440.2	73.4
3BY	0.480	600.0	0.139	0.082	0.053	0.041	0	0	0	0	0.263	85.1	339.6	56.6
3BY39-HTRS	0.480		0	0	0.007	0	0	0	0	0	0.007	100.0	8.8	
3BY40-HTRS	0.480		0	0	0.003	0	0	0	0	0	0.003	100.0	3.3	
3BYMM	0.460		0.005	0.003	0	0	0	0	0	0	0.006	83.0	7.1	
3BYSM	0.480		0	0	0.004	0.002	0	0	0	0	0.004	85.0	5.6	
3D004-3A0409	4.160		0	0	0	0	0	0	0	0	0.443	92.0	61.8	
3DC04-3P018	4.160		0.408	0.174	0	0	0	0	0	0	0.443	92.0	61.8	
3HV9377-N	0.480		0	0	0.002	0.001	0	0	0	0	0.002	90.0	2.2	
3L111	0.480		0.125	0.049	0.049	0.019	0	0	0	0	0.186	93.2	251.7	
3L707-3BRA06	0.480		0	0	0	0	0	0	0	0	0.002	90.0	2.2	
3PEXCC5	4.160		1.770	0.907	0	0	0	0	0	0	1.989	89.0	286.4	
3Q020	0.480		0	0	0.003	0.002	0	0	0	0	0.004	85.0	5.4	
3Q039	0.480		0	0	0.015	0.009	0	0	0	0	0.017	85.0	22.4	
3Q074	0.480		0	0	0.004	0.002	0	0	0	0	0.004	85.0	5.6	
3T063	0.480		0	0	0.019	0.011	0	0	0	0	0.022	85.0	28.1	
3XR1-X	4.160		0	0	0	0	0	0	0	0	5.430	88.1	755.8	
3XR1-Y	4.160		0	0	0	0	0	0	0	0	19.668	87.6	2820.2	
ASC1	4.160	400.0	0.232	0.115	0	0	0	0	0	0	0.259	89.5	37.3	9.3
B10	0.480	2000.0	0.063	0.040	0.080	0	0	0	0	0	0.732	95.3	933.1	46.7
B10XBHS	4.160		0	0	0	0	0	0	0	0	0.749	93.9	107.7	
BO	0.480	600.0	0.021	0.014	0.251	0.018	0	0	0	0	0.274	99.3	351.3	58.5
BP	0.480	600.0	0.163	0.108	0.108	0.035	0	0	0	0	0.306	88.5	395.5	65.9
BQ	0.480	600.0	0.061	0.038	0.046	0.026	0	0	0	0	0.147	85.6	191.1	31.8
BQMM	0.460		0.005	0.003	0	0	0	0	0	0	0.006	83.0	7.1	
BQSM	0.480		0	0	0.004	0.002	0	0	0	0	0.004	85.0	5.6	
BT	0.480	600.0	0.168	0.100	0.197	0.102	0	0	0	0	0.417	87.6	560.6	93.4
BT-3B1603	0.480		0	0	0	0	0	0	0	0	0.417	87.6	560.6	
D007-3A0402	4.160		0	0	0	0	0	0	0	0	0.523	87.2	72.9	
D007-E336	4.160		0.456	0.256	0	0	0	0	0	0	0.523	87.2	72.9	
D645	0.480		0	0	0.008	0	0	0	0	0	0.008	100.0	10.2	

AUXILIARY SYSTEM VOLTAGE REGULATION

ICCN C - 130

CCN No. \_\_\_\_\_

Project: E4C-090 REV.3 ICCN C-130

ETAP

Page: 21

Location: SONGS 2 & 3

5.0.0N

Date: 05-24-2005

Contract:

SN: SCALEDISON

Engineer: W. P. Lennartz

Study Case: 3A14aa

Revision: Base

Filename: E4C090

Config.: 090-3A14aa

ECP 050500255 - 34 ICCN C-130 UNIT 3 TRAIN A

Bus			Directly Connected Load								Total Bus Load			Percent Loading
			Constant kVA		Constant Z		Constant I		Generic		MVA	% PF	Amp	
ID	kV	Rated Amp	MW	Mvar	MW	Mvar	MW	Mvar	MW	Mvar				
DB0415-3B0418	0.480		0	0	0	0	0	0	0	0	0.132	84.1	171.5	
DB0415-E418	0.480		0.111	0.071	0	0	0	0	0	0	0.132	84.1	171.5	
Q033	0.480		0	0	0.011	0.007	0	0	0	0	0.013	85.0	16.7	
SWITCHYARD	230.000		0	0	0	0	0	0	0	0	26.113	84.6	69.5	
SWITCHYARD-3	230.000		0	0	0	0	0	0	0	0	26.113	84.6	69.5	
ZTB45	0.480		0	0	0	0	0	0	0	0	0.008	100.0	10.2	

\* Indicates operating load of a bus exceeds the bus critical limit ( % of the Continuous Ampere rating).

# Indicates operating load of a bus exceeds the bus marginal limit ( % of the Continuous Ampere rating).



## AUXILIARY SYSTEM VOLTAGE REGULATION

ICCN C - 130

CCN No. \_\_\_\_\_

Project: E4C-090 REV.3 ICCN C-130

ETAP

Page: 22

Location: SONGS 2 &amp; 3

5.0.0N

Date: 05-24-2005

Contract:

SN: SCALEDISON

Engineer: W. P. Lennartz

Study Case: 3A14aa

Revision: Base

Filename: E4C090

Config.: 090-3A14aa

ECP 050500255 - 34 ICCN C-130 UNIT 3 TRAIN A

Branch Loading Summary Report

CKT / Branch		Cable & Reactor			Transformer				
ID	Type	Ampacity (Amp)	Loading Amp	%	Capability (MVA)	Loading (Input)		Loading (output)	
						MVA	%	MVA	%
3B01X	Transformer				1.500	0.459	30.6	0.450	30.0
3B02X	Transformer				1.000	0.578	57.8	0.570	57.0
3B03X	Transformer				1.000	0.709	70.9	0.685	68.5
3B04X	Transformer				1.500	1.410	94.0	1.325	88.4
3B12X	Transformer				1.500	0.884	58.9	0.846	56.4
3B13X	Transformer				1.000	0.426	42.6	0.418	41.8
3B16X	Transformer				1.500	1.175	78.3	1.117	74.4
B10X-B	Transformer				1.500	0.749	49.9	0.732	48.8
3XR1	3W XFMR p				40.000	26.113	65.3		
	3W XFMR s				13.300	5.430	40.8		
	3W XFMR t				26.700	19.668	73.7		

\* Indicates a branch with operating load exceeding the branch capability.

AUXILIARY SYSTEM VOLTAGE REGULATION

ICCN C - 130

CCN No. \_\_\_\_\_

Project: E4C-090 REV.3 ICCN C-130  
 Location: SONGS 2 & 3  
 Contract:  
 Engineer: W. P. Lennartz  
 Filename: E4C090

ETAP  
 5.0.0N  
 Study Case: 3A14aa

Page: 23  
 Date: 05-24-2005  
 SN: SCALEDISON  
 Revision: Base  
 Config.: 090-3A14aa

ECP 050500255 - 34 ICCN C-130 UNIT3 TRAIN A

Branch Losses Summary Report

CKT / Branch ID	From-To Bus Flow		To-From Bus Flow		Losses		% Bus Voltage		Vd % Drop in Vmag
	MW	Mvar	MW	Mvar	kW	kvar	From	To	
3XA0304P1	0.384	0.185	-0.384	-0.185	0.0	0.0	96.6	96.5	0.01
3XA0309P1	0.232	0.115	-0.232	-0.115	0.1	0.0	96.6	96.5	0.02
3XA0310P1	0.761	0.451	-0.761	-0.451	0.2	0.1	96.6	96.5	0.02
3XA0311P1	0.608	0.365	-0.608	-0.365	0.1	0.0	96.6	96.5	0.01
3XA0312P1	1.773	0.909	-1.770	-0.907	2.4	2.1	96.6	96.4	0.15
3XXR169PA-PD,P9	-13.758	-7.891	13.782	7.927	24.3	36.0	96.6	96.8	0.24
3AA0402P1	0.456	0.256	-0.456	-0.256	0.0	0.0	99.5	99.5	0.01
3AA0409P1	0.408	0.174	-0.408	-0.174	0.2	0.1	99.5	99.4	0.05
3AA0417P1	1.188	0.761	-1.188	-0.760	0.4	0.3	99.5	99.4	0.04
3XXR169P1-P3	-4.774	-2.562	4.782	2.573	7.5	11.1	99.5	99.7	0.22
3XA0801P1	0.703	0.258	-0.703	-0.258	0.3	0.2	96.6	96.5	0.05
3XA0802P1	0.971	0.661	-0.971	-0.661	0.3	0.2	96.6	96.5	0.03
3XA0808P1	0.396	0.232	-0.396	-0.232	0.1	0.1	96.6	96.5	0.04
3XA0809P1	0.575	0.062	-0.575	-0.062	0.3	0.2	96.6	96.5	0.05
3XXR169P7,P8	-3.441	-1.552	3.447	1.560	5.6	8.3	96.6	96.8	0.22
3XB0102P1	0.263	0.140	-0.262	-0.139	0.7	1.1	92.4	92.0	0.36
3B01X	-0.394	-0.218	0.396	0.232	2.1	14.2	92.4	96.5	4.17
3XB0205P1	0.190	0.001	-0.189	0.000	0.8	0.5	95.2	94.8	0.40
3XB0206P1	0.190	0.001	-0.189	0.000	0.8	0.5	95.2	94.8	0.40
3XB0210P1,P2	0.141	0.000	-0.141	0.000	0.8	0.4	95.2	94.7	0.57
3B02X	-0.569	-0.033	0.575	0.062	5.4	28.4	95.2	96.5	1.28
3XB0306P1	0.238	0.107	-0.235	-0.102	3.0	4.7	93.2	91.5	1.65
3XB0314P1	0.160	0.095	-0.157	-0.091	3.4	4.3	93.2	90.6	2.57
3B03X	-0.604	-0.322	0.608	0.365	4.0	43.5	93.2	96.5	3.39
3AB0403P1	0.014	0.008	-0.014	-0.008	0.0	0.0	93.5	93.4	0.01
3AB0407P1	0.147	0.101	-0.142	-0.096	5.6	5.7	93.5	89.4	4.10
3AB0414P1	0.101	0.055	-0.101	-0.055	0.1	0.1	93.5	93.4	0.10
3AB0415P1	0.224	0.139	-0.224	-0.138	0.3	0.5	93.5	93.3	0.18
3AB0417P1	0.127	0.077	-0.126	-0.076	0.9	0.9	93.5	92.7	0.80
3AB0418P1	0.112	0.072	-0.111	-0.071	1.1	0.6	93.5	92.6	0.90
3XB0402P1	0.181	0.002	-0.179	0.000	2.0	2.0	93.5	92.4	1.05
3B04X	-1.168	-0.627	1.188	0.760	20.1	133.5	93.5	99.4	5.99
3XB1202P1	0.202	0.124	-0.201	-0.122	1.5	2.3	92.4	91.4	0.94
3XB1203P1	0.051	0.027	-0.051	-0.027	0.2	0.3	92.4	91.8	0.54
3XB1211P1	0.179	0.073	-0.174	-0.068	5.3	5.4	92.4	89.1	3.31

AUXILIARY SYSTEM VOLTAGE REGULATION

ICCN C - 130

CCN No. \_\_\_\_\_

Project: E4C-090 REV.3 ICCN C-130

ETAP

Page: 24

Location: SONGS 2 & 3

5.0.0N

Date: 05-24-2005

Contract:

SN: SCALEDISON

Engineer: W. P. Lennartz

Study Case: 3A14aa

Revision: Base

Filename: E4C090

Config.: 090-3A14aa

ECP 050500255 - 34 ICCN C-130 UNIT 3 TRAIN A

CKT / Branch ID	From-To Bus Flow		To-From Bus Flow		Losses		% Bus Voltage		Vd % Drop in Vmag
	MW	Mvar	MW	Mvar	kW	kvar	From	To	
3B12X	-0.754	-0.383	0.761	0.451	6.1	68.0	92.4	96.5	4.16
3XB1303P1	0.051	0.026	-0.051	-0.026	0.1	0.1	94.7	94.5	0.26
3XB1305P1	0.106	0.063	-0.105	-0.062	1.0	1.3	94.7	93.6	1.16
3B13X	-0.382	-0.169	0.384	0.185	1.4	15.8	94.7	96.5	1.79
3XB1602P1	0.304	0.143	-0.300	-0.137	3.6	5.7	91.8	90.2	1.56
3XB1603P1,P2	0.373	0.210	-0.365	-0.201	8.1	8.2	91.8	89.4	2.37
3XB1611P1	0.124	0.108	-0.121	-0.105	2.4	2.4	91.8	89.9	1.88
3B16X	-0.961	-0.569	0.971	0.661	10.5	91.5	91.8	96.5	4.76
3ABRA06P1	0.002	0.001	-0.002	-0.001	0.0	0.0	93.4	93.3	0.12
0XB1002P1	0.273	0.147	-0.271	-0.143	2.3	3.6	94.3	93.2	1.13
0XB1014P1	0.273	0.034	-0.272	-0.032	1.4	2.1	94.3	93.8	0.55
0XB1015P1	0.008	0.000	-0.008	0.000	0.0	0.0	94.3	94.2	0.18
B10X-B	-0.698	-0.221	0.703	0.258	5.4	36.4	94.3	96.5	2.18
0XB1015P2	-0.008	0.000	0.008	0.000	0.0	0.0	94.1	94.2	0.04
3XR1	22.088	13.930	-4.782	-2.573	77.1	1869.5	94.3	99.7	0.83
			-17.229	-9.487			94.3	96.8	1.95
					219.2	2412.4			

AUXILIARY SYSTEM VOLTAGE REGULATION

ICCN C - 130

CCN No. \_\_\_\_\_

Project: E4C-090 REV.3 ICCN C-130

ETAP

Page: 25

Location: SONGS 2 & 3

5.0.0N

Date: 05-24-2005

Contract:

SN: SCALEDISON

Engineer: W. P. Lennartz

Study Case: 3A14aa

Revision: Base

Filename: E4C090

Config.: 090-3A14aa

ECP 050500255 - 34 ICCN C - 130 UNIT 3 TRAIN A

Equipment Cable and Heater Losses Summary Report

Connected Load		Cable/Heater		Losses		% Voltage			% Vd Operating	% Vst Starting
ID	Type	ID	Library	kW	kvar	Bus	Bus kV	Load kV		
3P117	Ind. Motor	3XA0305P1	8.0MCUN3	4.0	4.6	96.55	96.33	96.33	0.22	95.60
3P115	Ind. Motor	3XA0306P1	8.0MCUN3	3.6	4.2	96.55	96.35	96.35	0.20	95.69
3P051	Ind. Motor	3XA0307P1	8.0MCUN3	1.0	1.5	96.55	96.50	96.50	0.05	96.16
3P050	Ind. Motor	3XA0308P1	8.0MCUN3	0.7	1.0	96.55	96.51	96.51	0.04	96.29
3P120	Ind. Motor	3XA0313P1	8.0MCUN3	3.2	2.1	96.55	96.24	96.24	0.31	95.51
3P307	Ind. Motor	3AA0411P1	8.0MCUN3	0.2	0.1	99.49	99.42	99.42	0.06	99.21
3P012	Ind. Motor	3AA0403P1	8.0MCUN3	0.1	0.1	99.49	99.44	99.44	0.04	99.24
3P024	Ind. Motor	3AA0405P1	8.0MCUN3	0.3	0.2	99.49	99.42	99.42	0.06	99.19
3P017	Ind. Motor	3AA0408P1	8.0MCUN3	0.2	0.1	99.49	99.43	99.43	0.06	99.16
3P141	Ind. Motor	3AA0404P1	8.0MCUN3	1.0	0.7	99.49	99.33	99.33	0.16	98.77
3P015	Ind. Motor	3AA0407P1	8.0MCUN3	0.2	0.1	99.49	99.43	99.43	0.06	99.24
3E202	Ind. Motor	3XA0803P1	8.0MCUN3	0.4	0.2	96.57	96.52	96.52	0.05	96.35
3P018	Ind. Motor	3WAD004P1	8.0MCUN3	0.0	0.0	99.44	99.44	99.44	0.01	99.41
3P058	Ind. Motor	3XA0312P2	5.0MCUS1	0.4	0.5	96.40	96.38	96.38	0.03	96.26
C443	Ind. Motor	0XAC101P2	8.0MCUN1	0.0	0.0	96.53	96.52	96.52	0.01	96.47
E336	Ind. Motor	0AAD007P1	8.0MCUN3	0.2	0.1	99.48	99.43	99.43	0.04	99.31
3E397	Ind. Motor	3XB0106P1-P3	0.6MCUN1	0.5	0.2	92.36	91.57	95.55	0.79	89.46
3P128	Ind. Motor	3XB0110P1	0.6MCUN1	1.5	0.7	92.36	90.75	94.69	1.62	86.33
3E394	Ind. Motor	3XB0209P1-P3	0.6MCUN1	0.7	0.2	95.24	94.13	98.22	1.12	90.91
3P075	Ind. Motor	3XB0303P1	0.6MCUN1	0.7	0.3	93.15	92.27	96.28	0.88	90.47
3P290	Ind. Motor	3XB0309P1	0.6MCUN1	0.5	0.2	93.15	92.35	96.36	0.80	90.80
3A001	Ind. Motor	3XB0310P1,P2	0.6MCUN1	1.3	0.5	93.15	91.78	95.78	1.37	88.90
3A074	Ind. Motor	3AB0419P1-P3	0.6MCUN1	1.0	0.4	93.46	91.72	95.71	1.73	86.05
3A071	Ind. Motor	3AB0409P1-P3	0.6MCUN1	0.9	0.3	93.46	91.90	95.90	1.55	86.80
3E399	Ind. Motor	3AB0410P1-P3	0.6MCUN1	0.6	0.4	93.46	92.48	96.50	0.98	87.27
3E401	Ind. Motor	3AB0411P1-P3	0.6MCUN1	0.6	0.4	93.46	92.47	96.50	0.98	87.25
3P190	Ind. Motor	3AB0413P1	0.6MCUN1	0.6	0.3	93.46	92.48	96.50	0.98	88.89
3P127	Ind. Motor	3XB1206P1-P3	0.6MCUN1	5.6	7.0	92.37	89.05	92.92	3.31	77.14
3P135	Ind. Motor	3XB1306P1	0.6MCUN1	6.9	4.8	94.75	90.12	94.04	4.63	78.41
3L046	Ind. Motor	3XB1606P1,P2	0.6MCUN1	0.6	0.5	91.78	91.05	95.00	0.74	85.83
3A274	Ind. Motor	3ABD12P1	0.6MCUN3	0.1	0.0	89.36	89.18	93.05	0.18	88.87
3A275	Ind. Motor	3ABD13P1	0.6MCUN3	0.2	0.0	89.36	88.98	92.85	0.38	88.33
3E550	Ind. Motor	3ABD21P1	0.6MCUN3	0.3	0.1	89.36	88.73	92.59	0.62	87.72
3E546	Ind. Motor	3ABD22P1	0.6MCUN3	0.2	0.0	89.36	88.84	92.70	0.52	88.00

AUXILIARY SYSTEM VOLTAGE REGULATION

ICCN C - 130

CCN No. \_\_\_\_\_

Project: E4C-090 REV.3 ICCN C-130

ETAP

Page: 26

Location: SONGS 2 & 3

5.0.0N

Date: 05-24-2005

Contract:

SN: SCALEDISON

Engineer: W. P. Lennartz

Study Case: 3A14aa

Revision: Base

Filename: E4C090

Config.: 090-3A14aa

ECP 050500255 - 34 ICCN C-130 UNIT 3 TRAIN A

Equipment Cable and Heater Losses Summary Report

Connected Load		Cable/Heater		Losses		% Voltage			% Vd Operating	% Vst Starting
ID	Type	ID	Library	kW	kvar	Bus	Bus kV	Load kV		
3P093	Ind. Motor	3ABD23P1	0.6MCUN3	0.0	0.0	89.36	89.24	93.12	0.12	89.15
3P096	Ind. Motor	3ABD24P1	0.6MCUN3	0.0	0.0	89.36	89.24	93.12	0.12	89.15
3P997/3P1014	Ind. Motor	3ABD11P1	0.6MCUN3	0.0	0.0	89.36	89.25	93.13	0.11	89.17
3P996/3P1015	Ind. Motor	3ABD10P1	0.6MCUN3	0.0	0.0	89.36	89.16	93.04	0.20	89.02
3HV4731	Ind. Motor	3ABE36P1	0.6MCUN3	0.0	0.0	93.35	92.71	96.74	0.64	92.15
3A373	Ind. Motor	3ABY08P1	0.6MCUN3	0.1	0.0	93.28	91.70	95.69	1.57	88.49
3A370	Ind. Motor	3ABY07P1	0.6MCUN3	0.1	0.0	93.28	92.06	96.07	1.21	89.73
3P1018	Ind. Motor	3ABY10P1	0.6MCUN3	0.1	0.0	93.28	91.81	95.80	1.46	90.67
3E439	Ind. Motor	3ABY11P1	0.6MCUN3	0.0	0.0	93.28	93.22	97.27	0.06	92.67
3E440	Ind. Motor	3ABY12P1	0.6MCUN3	0.0	0.0	93.28	93.22	97.27	0.06	92.67
3P174	Ind. Motor	3ABY14P1	0.6MCUN3	0.5	0.0	93.28	91.53	95.50	1.75	90.03
3P175	Ind. Motor	3ABY15P1	0.6MCUN3	0.5	0.0	93.28	91.53	95.50	1.75	90.03
3E437	Ind. Motor	3ABY20P1	0.6MCUN3	0.0	0.0	93.28	93.18	97.23	0.10	92.59
3E438	Ind. Motor	3ABY21P1	0.6MCUN3	0.0	0.0	93.28	93.18	97.23	0.10	92.59
3E427	Ind. Motor	3ABY22P1	0.6MCUN3	0.0	0.0	93.28	92.96	97.01	0.31	92.24
3E417	Ind. Motor	3ABY24P1	0.6MCUN3	0.1	0.0	93.28	91.90	95.90	1.38	89.88
3E517	Ind. Motor	3ABY25P1	0.6MCUN3	0.0	0.0	93.28	92.99	97.03	0.29	92.07
3E453	Ind. Motor	3ABY30P1	0.6MCUN3	0.0	0.0	93.28	93.04	97.08	0.24	92.30
3E454	Ind. Motor	3ABY31P1	0.6MCUN3	0.0	0.0	93.28	93.06	97.11	0.21	92.48
3P009	Ind. Motor	3ABY34P1	0.6MCUN3	0.3	0.1	93.28	92.23	96.24	1.04	90.46
3A394	Ind. Motor	3ABY36P1	0.6MCUN3	0.1	0.0	93.28	91.54	95.52	1.74	87.70
3E441	Ind. Motor	3ABY37P1	0.6MCUN3	0.0	0.0	93.28	92.98	97.03	0.29	92.42
3E370	Ind. Motor	3ABY38P1	0.6MCUN3	1.0	0.2	93.28	91.42	95.40	1.85	88.40
P159	Ind. Motor	0XB1006P1	0.6MCUN1	1.4	0.5	94.34	92.45	96.47	1.89	88.35
P162	Ind. Motor	0ABQ24P1	0.6MCUN3	0.4	0.1	92.66	91.41	95.39	1.25	89.09
2A173	Ind. Motor	0ABQ07P1	0.6MCUN3	0.0	0.0	92.66	91.80	95.79	0.86	89.66
2E255	Ind. Motor	0ABQ08P1	0.6MCUN3	0.1	0.0	92.66	91.80	95.79	0.86	90.41
A207	Ind. Motor	0ABQ09P2	0.6MCUN3	0.4	0.0	92.66	89.27	93.15	3.39	85.74
3A173	Ind. Motor	0ABQ14P1	0.6MCUN3	0.0	0.0	92.66	91.77	95.76	0.89	89.57
3E255	Ind. Motor	0ABQ15P1	0.6MCUN3	0.1	0.0	92.66	91.27	95.24	1.39	88.82
P445	Ind. Motor	0ABQ20P1	0.6MCUN3	0.0	0.0	92.66	91.85	95.84	0.81	91.23
AG53	Ind. Motor	0ABQ22P1	0.6MCUN3	0.1	0.0	92.66	91.43	95.41	1.23	88.63
A056	Ind. Motor	0ABQ23P1	0.6MCUN3	0.0	0.0	92.66	92.24	96.25	0.42	90.54
W310	Ind. Motor	0ABQ25P1	0.6MCUN3	0.0	0.0	92.66	91.62	95.60	1.04	90.85

AUXILIARY SYSTEM VOLTAGE REGULATION

ICCN C - 130

CCN No. \_\_\_\_\_

Project: E4C-090 REV.3 ICCN C-130

ETAP

Page: 27

Location: SONGS 2 & 3

5.0.0N

Date: 05-24-2005

Contract:

SN: SCALEDISON

Engineer: W. P. Lennartz

Study Case: 3A14aa

Revision: Base

Filename: E4C090

Config.: 090-3A14aa

ECP 050500255 - 34 ICCN C-130 UNIT 3 TRAIN A

Equipment Cable and Heater Losses Summary Report

Connected Load		Cable/Heater		Losses		% Voltage			% Vd Operating	% Vst Starting
ID	Type	ID	Library	kW	kvar	Bus	Bus kV	Load kV		
E418	Ind. Motor	0ABD415P1	0.6MCUN1	3.1	1.8	92.55	90.02	93.93	2.53	80.74
2L270	St. Load	0ABQ05P1	0.6MCUN3	0.1	0.0	92.66	91.00	91.00	1.66	0.00
3B001	St. Load	3ABY03P1	0.6MCUN1	0.1	0.0	93.28	92.99	92.99	0.29	0.00
3B003	St. Load	3ABE04P1	0.6MCUN1	0.1	0.0	93.35	93.07	93.07	0.28	0.00
3B005	St. Load	3XB1609P2	0.6MCUN1	0.8	0.4	91.78	90.94	90.94	0.84	0.00
3E122-H1	St. Load	3XB0210P3-P5	0.6MCUN3	0.6	0.1	94.68	93.48	93.48	1.19	0.00
3E124-H1	St. Load	3XB0206P2-P4	0.6MCUN3	0.6	0.1	94.84	93.62	93.62	1.22	0.00
3E126-H1	St. Load	3XB0205P2,P3,PE	0.6MCUN3	0.6	0.1	94.84	93.66	93.66	1.19	0.00
3E128-H1 [X]	St. Load	3XB0402P2,P3,P4	0.6MCUN3	0.6	0.1	92.41	91.12	91.12	1.28	0.00
3E37CH	St. Load	3ABY39P6	0.6MCUN3	0.0	0.0	93.28	93.04	93.04	0.24	0.00
3E399H	St. Load	3ABY40P6,P7,P8	0.6MCUN3	0.0	0.0	93.28	93.09	93.09	0.18	0.00
3E401H	St. Load	3ABY40P9,PA,PB	0.6MCUN3	0.0	0.0	93.28	93.13	93.13	0.15	0.00
3E464	St. Load	3ABE03P1,P2	0.6MCUN3	0.3	0.0	93.35	92.30	92.30	1.05	0.00
3E652	St. Load	3ABE49P1,P2	0.6MCUN3	0.1	0.0	93.35	91.85	91.85	1.49	0.00
3L266	St. Load	3ABE42P1	0.6MCUN3	0.2	0.0	93.35	92.21	92.21	1.14	0.00
3L270	St. Load	0ABQ06P1	0.6MCUN3	0.2	0.0	92.66	90.06	90.06	2.60	0.00
3L411[X]	St. Load	3XBY23P1	0.6MCUN3	0.0	0.0	93.28	93.16	93.16	0.12	0.00
3P012H	St. Load	3ABY40P1	0.6MCUN3	0.0	0.0	93.28	92.10	92.10	1.17	0.00
3P015H	St. Load	3ABY39P1	0.6MCUN3	0.0	0.0	93.28	92.11	92.11	1.16	0.00
3P017H	St. Load	3ABY39P2	0.6MCUN3	0.0	0.0	93.28	91.56	91.56	1.72	0.00
3P018HA	St. Load	3ABY39P3	0.6MCUN3	0.0	0.0	93.28	92.02	92.02	1.26	0.00
3P112H	St. Load	3ABY39P4	0.6MCUN3	0.0	0.0	93.28	92.97	92.97	0.31	0.00
3P141H	St. Load	3ABY39P8	0.6MCUN3	0.0	0.0	93.28	92.46	92.46	0.81	0.00
3P174H	St. Load	3ABY40P2	0.6MCUN3	0.0	0.0	93.28	93.20	93.20	0.08	0.00
3P175H	St. Load	3ABY40P3	0.6MCUN3	0.0	0.0	93.28	93.22	93.22	0.06	0.00
3P190H	St. Load	3ABY40P4	0.6MCUN3	0.0	0.0	93.28	93.20	93.20	0.08	0.00
3P191HA	St. Load	3ABY40P5	0.6MCUN3	0.0	0.0	93.28	93.21	93.21	0.06	0.00
3P307H	St. Load	3ABY39P5	0.6MCUN3	0.0	0.0	93.28	92.98	92.98	0.30	0.00
3P1018H	St. Load	3ABY39P9	0.6MCUN3	0.0	0.0	93.28	93.19	93.19	0.08	0.00
3RU7804-1	St. Load	3ABE41P1	0.6MCUN3	0.0	0.0	93.35	92.72	92.72	0.63	0.00
3RU7822-1	St. Load	3ABE02P1	0.6MCUN3	0.0	0.0	93.35	91.99	91.99	1.36	0.00
3T011	St. Load	3XB1210P1	0.6MCUN1	1.1	1.1	92.37	91.34	91.34	1.02	0.00
3T014[X]	St. Load	3XA0412P1	0.6MCUN3	0.0	0.0	99.49	99.46	99.46	0.03	0.00
3T110/3Q071[X]	St. Load	3XBY33P2,P3	0.6MCUN1	0.8	0.2	93.28	89.59	89.59	3.69	0.00

AUXILIARY SYSTEM VOLTAGE REGULATION

ICCN C - 130

CCN No. \_\_\_\_\_

Project: E4C-090 REV.3 ICCN C - 130

ETAP

Page: 28

Location: SONGS 2 & 3

5.0.0N

Date: 05-24-2005

Contract:

SN: SCALEDISON

Engineer: W. P. Lennartz

Study Case: 3A14aa

Revision: Base

Filename: E4C090

Config.: 090-3A14aa

ECP 050500255 - 34 ICCN C - 130 UNIT 3 TRAIN A

Equipment Cable and Heater Losses Summary Report

Connected Load		Cable/Heater		Losses		% Voltage			% Vd Operating	% Vst Starting
ID	Type	ID	Library	kW	kvar	Bus	Bus kV	Load kV		
E297	St. Load	0ABQ04P1,P2	0.6MCUN3	0.1	0.0	92.66	90.73	90.73	1.93	0.00
E643	St. Load	0XB1011P1	0.6MCUN1	0.2	0.3	94.34	94.10	94.10	0.25	0.00
E645	St. Load	0XB1015P3	0.6MCUN3	0.0	0.0	94.13	94.08	94.08	0.05	0.00
L211-1	St. Load	0ABQ13P1	0.6MCUN3	0.1	0.0	92.66	92.36	92.36	0.30	0.00
L211-4	St. Load	0ABQ26P1	0.6MCUN3	0.1	0.0	92.66	92.26	92.26	0.40	0.00
L437(X)	St. Load	0XBQ11P1	0.6MCUN3	0.1	0.0	92.66	91.67	91.67	0.99	0.00
1P35A(X)	St. Load	3XBY19P1	0.6MCUN3	0.1	0.0	93.28	92.38	92.38	0.90	0.00
N002	St. Load	3XB1307P1	0.6MCUN1	2.8	1.1	94.75	91.11	91.11	3.64	0.00

**AUXILIARY SYSTEM VOLTAGE REGULATION**

ICCN C - 130

CCN No. \_\_\_\_\_

Project: E4C-090 REV.3 ICCN C-130

ETAP

Page: 29

Location: SONGS 2 & 3

5.0.0N

Date: 05-24-2005

Contract:

SN: SCALEDISON

Engineer: W. P. Lennartz

Study Case: 3A14aa

Revision: Base

Filename: E4C090

Config: 090-3A14aa

ECP 050500255 - 34 ICCN C - 130 UNIT 3 TRAIN A

Alert Summary Report

% Alert Settings

	<u>Critical</u>	
<u>Loading</u>		
Bus	0.0	0.0
Cable	0.0	0.0
Reactor	0.0	0.0
Line	100.0	95.0
Transformer	0.0	0.0
Panel	100.0	95.0
Protective Device	0.0	0.0
Generator	0.0	0.0
<u>Bus Voltage</u>		
OverVoltage	130.0	1000.0
UnderVoltage	70.0	-100.0
<u>Generator Excitation</u>		
OverExcited (Q Max.)	0.0	0.0
UnderExcited (Q Min.)		

Critical Report

<u>ID</u>	<u>Device Type</u>	<u>Rating</u>	<u>Unit</u>	<u>Calculated</u>	<u>%Mag.</u>	<u>Condition</u>
2G002	Generator	0.000	MW	0.000		UnderPower
2G003	Generator	0.000	MW	0.000		UnderPower
3G002	Generator	0.000	MW	0.003		UnderPower
3G003	Generator	0.000	MW	0.000		UnderPower



## AUXILIARY SYSTEM VOLTAGE REGULATION

ICCN C - 130

CCN No. \_\_\_\_\_

Project: E4C-090 REV. 3 ICCN C - 130

ETAP

Page: 30

Location: SONGS 2 &amp; 3

5.0.0N

Date: 05-24-2005

Contract:

SN: SCALEDISON

Engineer: W. P. Lennartz

Study Case: 3A14aa

Revision: Base

Filename: E4C090

Config.: 090-3A14aa

ECP 050500255 - 34 ICCN C - 130 UNIT 3 TRAIN A

SUMMARY OF TOTAL GENERATION, LOADING & DEMAND

	<u>MW</u>	<u>Mvar</u>	<u>MVA</u>	<u>% PF</u>
Source (Swing Buses):	22.088	13.930	26.113	84.58 Lagging
Source (Non-Swing Buses):	0.000	0.000	0.000	100.00 Lagging
Total Demand:	22.088	13.930	26.113	84.58 Lagging
Total Motor Load:	19.073	10.656	21.848	87.30 Lagging
Total Static Load:	2.795	0.861		
Apparent Losses:	0.219	2.412		
System Mismatch:	0.000	0.000		

Number of Iterations: 1