

March 2004

Revision 3

NAC-UMS

Universal MPC System

FINAL SAFETY ANALYSIS REPORT

for the UMS Universal Storage System

Docket No. 72-1015



Atlanta Corporate Headquarters: 3930 East Jones Bridge Road, Norcross, Georgia 30092 USA
Phone 770-447-1144, Fax 770-447-1797, www.nacintl.com

List of Effective Pages

Chapter 1	
1-i	Revision 3
1-ii	Revision 3
1-1	Revision 0
1-2	Revision 3
1-3	Revision 3
1-4	Revision 3
1-5	Amendment 2
1-6	Revision 3
1-7	Revision 3
1-8	Revision 3
1.1-1	Revision 3
1.1-2	Revision 3
1.1-3	Revision 3
1.1-4	Revision 0
1.2-1	Revision 3
1.2-2	Revision 3
1.2-3	Revision 3
1.2-4	Revision 3
1.2-5	Revision 3
1.2-6	Revision 3
1.2-7	Revision 3
1.2-8	Revision 3
1.2-9	Revision 3
1.2-10	Revision 3
1.2-11	Revision 3
1.2-12	Revision 3
1.2-13	Revision 3
1.2-14	Amendment 0
1.2-15	Revision 3
1.2-16	Amendment 0
1.2-17	Amendment 0
1.2-18	Amendment 0
1.2-19	Amendment 0
1.2-20	Revision 3
1.2-21	Revision 3
1.2-22	Revision 3
1.2-23	Revision 3
1.2-24	Revision 3
1.2-25	Revision 3
1.2-26	Revision 3
1.2-27	Revision 3
1.2-28	Revision 3
1.3-1	Revision 3
1.3-2	Revision 3
1.3-3	Amendment 2
1.4-1	Revision 0
1.4-2	Revision 0
1.5-1	Revision 0
1.5-2	Revision 0
1.5-3	Revision 0
1.5-4	Revision 0
1.5-5	Revision 3
1.5-6	Revision 0
1.5-7	Revision 0
1.5-8	Revision 3
1.5-9	Revision 3
1.5-10	Revision 0
1.5-11	Revision 3
1.5-12	Revision 0
1.5-13	Revision 0
1.5-14	Revision 0
1.5-15	Revision 0
1.5-16	Revision 0
1.5-17	Revision 3
1.5-18	Revision 0
1.5-19	Revision 0
1.5-20	Revision 0

List of Effective Pages (continued)

1.5-21	Revision 3	1.6-2	Revision 3
1.5-22	Revision 3	1.7-1	Revision 3
1.5-23	Revision 0	1.7-2	Revision 3
1.5-24	Revision 0	1.7-3	Revision 3
1.5-25	Revision 0	1.8-1	Revision 3
1.5-26	Revision 0	1.8-2	Revision 3
1.5-27	Revision 3		
1.5-28	Revision 0	31 drawings (see Section 1.8)	
1.5-29	Revision 0		
1.5-30	Revision 0		
1.5-31	Revision 0		
1.5-32	Revision 0		
1.5-33	Revision 3		
1.5-34	Revision 3		
1.5-35	Revision 0		
1.5-36	Revision 3		
1.5-37	Amendment 2		
1.5-38	Revision 3		
1.5-39	Revision 0		
1.5-40	Revision 0		
1.5-41	Revision 0		
1.5-42	Revision 0		
1.5-43	Revision 0		
1.5-44	Revision 3		
1.5-45	Revision 0		
1.5-46	Revision 0		
1.5-47	Revision 3		
1.5-48	Revision 3		
1.5-49	Revision 0		
1.5-50	Revision 0		
1.5-51	Revision 0		
1.5-52	Revision 0		
1.5-53	Revision 0		
1.5-54	Revision 0		
1.6-1	Revision 3		

Chapter 2

2-i	Revision 3
2-ii	Revision 3
2-iii	Revision 3
2-iv	Revision 3
2-1	Revision 0
2-2	Revision 3
2-3	Revision 3
2.1-1	Revision 3
2.1.1-1	Revision 3
2.1.1-2	Revision 3
2.1.1-3	Revision 3
2.1.2-1	Revision 3
2.1.2-2	Revision 3
2.1.2-3	Revision 3
2.1.3-1	Revision 3
2.1.3-2	Revision 3
2.1.3-3	Revision 3
2.1.3-4	Revision 3
2.1.3-5	Revision 3
2.1.3-6	Revision 3
2.1.3-7	Revision 3
2.1.3-8	Revision 3
2.1.3-9	Revision 3
2.1.3-10	Revision 3
2.1.3-11	Revision 3

List of Effective Pages (continued)

2.1.3-12	Revision 3	2.4-2	Revision 0
2.1.3-13	Revision 3	2.4-3	Revision 0
2.1.3-14	Revision 3	2.4-4	Revision 0
2.2-1	Amendment 1	2.5-1	Revision 3
2.2-2	Revision 0	2.5-2	Revision 3
2.2-3	Revision 0		
2.2-4	Revision 3		
2.2-5	Revision 3		
2.2-6	Revision 0		
2.2-7	Revision 0		
2.2-8	Revision 0		
2.2-9	Revision 0		
2.2-10	Revision 0		
2.2-11	Revision 3		
2.3-1	Amendment 2		
2.3-2	Amendment 2		
2.3-3	Revision 3		
2.3-4	Revision 3		
2.3-5	Revision 3		
2.3-6	Revision 3		
2.3-7	Revision 0		
2.3-8	Revision 3		
2.3-9	Revision 3		
2.3-10	Revision 0		
2.3-11	Revision 3		
2.3-12	Revision 3		
2.3-13	Revision 3		
2.3-14	Revision 3		
2.3-15	Revision 3		
2.3-16	Revision 3		
2.3-17	Revision 3		
2.3-18	Revision 3		
2.3-19	Revision 3		
2.3-20	Revision 3		
2.4-1	Revision 3		

Chapter 3

3-i	Revision 3
3-ii	Revision 3
3-iii	Revision 3
3-iv	Revision 3
3-v	Revision 3
3-vi	Revision 3
3-vii	Revision 3
3-viii	Revision 3
3.1-1	Revision 3
3.1-2	Revision 3
3.1-3	Revision 3
3.1-4	Revision 3
3.1-5	Revision 3
3.1-6	Revision 3
3.1-7	Revision 3
3.2-1	Revision 0
3.2-2	Revision 3
3.2-3	Revision 3
3.2-4	Revision 3
3.3-1	Revision 3
3.3-2	Revision 3
3.3-3	Revision 3
3.3-4	Revision 3
3.3-5	Revision 3
3.3-6	Revision 3
3.3-7	Revision 3
3.3-8	Revision 3
3.3-9	Revision 3

List of Effective Pages (continued)

3.3-10	Revision 3	3.4.3-15	Revision 3
3.3-11	Revision 3	3.4.3-16	Revision 3
3.3-12	Revision 3	3.4.3-17	Revision 3
3.3-13	Revision 3	3.4.3-18	Revision 3
3.3-14	Revision 3	3.4.3-19	Revision 3
3.3-15	Revision 3	3.4.3-20	Revision 3
3.3-16	Revision 3	3.4.3-21	Revision 3
3.4.1-1	Amendment 2	3.4.3-22	Revision 3
3.4.1-2	Revision 3	3.4.3-23	Revision 3
3.4.1-3	Amendment 2	3.4.3-24	Revision 3
3.4.1-4	Amendment 2	3.4.3-25	Revision 3
3.4.1-5	Revision 3	3.4.3-26	Revision 3
3.4.1-6	Revision 3	3.4.3-27	Revision 3
3.4.1-7	Revision 3	3.4.3-28	Revision 3
3.4.1-8	Amendment 2	3.4.3-29	Revision 3
3.4.1-9	Revision 3	3.4.3-30	Revision 3
3.4.1-10	Revision 3	3.4.3-31	Revision 3
3.4.1-11	Revision 3	3.4.3-32	Revision 3
3.4.1-12	Revision 3	3.4.3-33	Revision 3
3.4.2-1	Revision 0	3.4.3-34	Revision 3
3.4.2-2	Revision 3	3.4.3-35	Revision 3
3.4.3-1	Revision 3	3.4.3-36	Revision 3
3.4.3-2	Revision 3	3.4.3-37	Revision 3
3.4.3-3	Revision 3	3.4.3-38	Revision 3
3.4.3-4	Revision 0	3.4.3-39	Revision 3
3.4.3-5	Revision 3	3.4.3-40	Revision 3
3.4.3-6	Revision 3	3.4.3-41	Revision 3
3.4.3-7	Revision 3	3.4.3-42	Revision 3
3.4.3-8	Revision 3	3.4.3-43	Revision 3
3.4.3-9	Revision 3	3.4.3-44	Revision 3
3.4.3-10	Revision 3	3.4.3-45	Revision 3
3.4.3-11	Revision 3	3.4.3-46	Revision 3
3.4.3-12	Revision 3	3.4.3-47	Revision 3
3.4.3-13	Revision 3	3.4.3-48	Revision 3
3.4.3-14	Revision 3	3.4.3-49	Revision 3

List of Effective Pages (continued)

3.4.3-50	Revision 3	3.4.3-85	Revision 3
3.4.3-51	Revision 3	3.4.3-86	Revision 3
3.4.3-52	Revision 3	3.4.3-87	Revision 3
3.4.3-53	Revision 3	3.4.3-88	Revision 3
3.4.3-54	Revision 3	3.4.3-89	Revision 3
3.4.3-55	Revision 3	3.4.3-90	Revision 3
3.4.3-56	Revision 3	3.4.3-91	Revision 3
3.4.3-57	Revision 3	3.4.3-92	Revision 3
3.4.3-58	Revision 3	3.4.3-93	Revision 3
3.4.3-59	Revision 3	3.4.3-94	Revision 3
3.4.3-60	Revision 3	3.4.3-95	Revision 3
3.4.3-61	Revision 3	3.4.3-96	Revision 3
3.4.3-62	Revision 3	3.4.3-97	Revision 3
3.4.3-63	Revision 3	3.4.3-98	Revision 3
3.4.3-64	Revision 3	3.4.4-1	Revision 0
3.4.3-65	Revision 3	3.4.4-2	Revision 3
3.4.3-66	Revision 3	3.4.4-3	Revision 3
3.4.3-67	Revision 3	3.4.4-4	Revision 3
3.4.3-68	Revision 3	3.4.4-5	Revision 3
3.4.3-69	Revision 3	3.4.4-6	Revision 3
3.4.3-70	Revision 3	3.4.4-7	Revision 3
3.4.3-71	Revision 3	3.4.4-8	Revision 0
3.4.3-72	Revision 3	3.4.4-9	Revision 3
3.4.3-73	Revision 3	3.4.4-10	Revision 0
3.4.3-74	Revision 3	3.4.4-11	Revision 3
3.4.3-75	Revision 3	3.4.4-12	Revision 3
3.4.3-76	Revision 3	3.4.4-13	Revision 3
3.4.3-77	Revision 3	3.4.4-14	Revision 3
3.4.3-78	Revision 3	3.4.4-15	Revision 3
3.4.3-79	Revision 3	3.4.4-16	Revision 3
3.4.3-80	Revision 3	3.4.4-17	Revision 3
3.4.3-81	Revision 3	3.4.4-18	Revision 3
3.4.3-82	Revision 3	3.4.4-19	Revision 3
3.4.3-83	Revision 3	3.4.4-20	Revision 3
3.4.3-84	Revision 3	3.4.4-21	Revision 0

List of Effective Pages (continued)

3.4.4-22	Revision 0	3.4.4-57	Revision 3
3.4.4-23	Revision 0	3.4.4-58	Revision 3
3.4.4-24	Revision 0	3.4.4-59	Revision 3
3.4.4-25	Revision 0	3.4.4-60	Revision 3
3.4.4-26	Revision 0	3.4.4-61	Revision 3
3.4.4-27	Revision 0	3.4.4-62	Revision 3
3.4.4-28	Revision 0	3.4.4-63	Revision 3
3.4.4-29	Revision 0	3.4.4-64	Revision 3
3.4.4-30	Revision 0	3.4.4-65	Revision 0
3.4.4-31	Revision 0	3.4.4-66	Revision 3
3.4.4-32	Revision 0	3.4.4-67	Revision 3
3.4.4-33	Revision 0	3.4.4-68	Revision 3
3.4.4-34	Revision 0	3.4.4-69	Revision 3
3.4.4-35	Revision 0	3.4.4-70	Revision 0
3.4.4-36	Revision 0	3.4.4-71	Revision 0
3.4.4-37	Revision 0	3.4.4-72	Revision 0
3.4.4-38	Revision 0	3.4.4-73	Revision 0
3.4.4-39	Revision 3	3.4.4-74	Revision 0
3.4.4-40	Revision 3	3.4.4-75	Revision 3
3.4.4-41	Revision 3	3.4.4-76	Revision 3
3.4.4-42	Revision 3	3.4.4-77	Revision 3
3.4.4-43	Revision 3	3.4.5-1	Revision 3
3.4.4-44	Revision 3	3.5-1	Revision 0
3.4.4-45	Revision 3	3.6-1	Revision 3
3.4.4-46	Revision 3	3.6-2	Amendment 2
3.4.4-47	Revision 3	3.6-3	Revision 3
3.4.4-48	Revision 3	3.6-4	Revision 3
3.4.4-49	Revision 0	3.6-5	Revision 3
3.4.4-50	Revision 0	3.6-6	Amendment 1
3.4.4-51	Revision 0	3.6-7	Revision 3
3.4.4-52	Revision 3	3.6-8	Revision 3
3.4.4-53	Revision 3	3.7-1	Revision 3
3.4.4-54	Revision 3	3.7-2	Revision 3
3.4.4-55	Revision 3	3.7-3	Revision 3
3.4.4-56	Revision 3	3.8-1	Revision 3

List of Effective Pages (continued)

3.8-2	Revision 0	4.2-6	Revision 0
3.8-3	Revision 0	4.2-7	Revision 3
3.8-4	Revision 0	4.3-1	Revision 3
3.8-5	Revision 0	4.3-2	Revision 3
3.8-6	Revision 0	4.3-3	Revision 3
3.8-7	Revision 0	4.4-1	Revision 3
3.8-8	Revision 0	4.4.1-1	Revision 3
3.8-9	Revision 0	4.4.1-2	Revision 3
3.8-10	Revision 0	4.4.1-3	Revision 3
3.8-11	Revision 0	4.4.1-4	Revision 0
3.8-12	Revision 3	4.4.1-5	Revision 0
3.8-13	Revision 3	4.4.1-6	Revision 0
3.8-14	Revision 3	4.4.1-7	Revision 0
3.8-15	Revision 3	4.4.1-8	Amendment 2
		4.4.1-9	Revision 3
		4.4.1-10	Revision 3
		4.4.1-11	Revision 3
		4.4.1-12	Revision 3
		4.4.1-13	Revision 3
		4.4.1-14	Revision 3
		4.4.1-15	Revision 3
		4.4.1-16	Revision 3
		4.4.1-17	Revision 3
		4.4.1-18	Revision 3
		4.4.1-19	Revision 3
		4.4.1-20	Revision 3
		4.4.1-21	Revision 3
		4.4.1-22	Revision 3
		4.4.1-23	Revision 3
		4.4.1-24	Revision 3
		4.4.1-25	Revision 3
		4.4.1-26	Revision 3
		4.4.1-27	Revision 3
		4.4.1-28	Revision 3
		4.4.1-29	Revision 3

Chapter 4

4-i	Revision 3
4-ii	Revision 3
4-iii	Revision 3
4-iv	Revision 3
4-v	Revision 3
4-vi	Revision 3
4.1-1	Revision 3
4.1-2	Revision 3
4.1-3	Revision 3
4.1-4	Revision 0
4.1-5	Revision 3
4.1-6	Revision 3
4.1-7	Revision 3
4.1-8	Revision 3
4.2-1	Revision 3
4.2-2	Revision 3
4.2-3	Revision 3
4.2-4	Revision 0
4.2-5	Revision 0

List of Effective Pages (continued)

4.4.1-30	Revision 3	4.4.3-15	Revision 3
4.4.1-31	Revision 3	4.4.3-16	Revision 3
4.4.1-32	Revision 3	4.4.3-17	Revision 3
4.4.1-33	Revision 3	4.4.3-18	Revision 3
4.4.1-34	Revision 3	4.4.3-19	Revision 3
4.4.1-35	Revision 3	4.4.3-20	Revision 3
4.4.1-36	Revision 3	4.4.3-21	Revision 3
4.4.1-37	Revision 3	4.4.3-22	Revision 3
4.4.1-38	Revision 3	4.4.4-1	Revision 0
4.4.1-39	Revision 3	4.4.5-1	Revision 3
4.4.1-40	Revision 3	4.4.5-2	Revision 3
4.4.1-41	Revision 3	4.4.5-3	Revision 3
4.4.1-42	Revision 3	4.4.5-4	Revision 3
4.4.1-43	Revision 3	4.4.5-5	Revision 3
4.4.1-44	Revision 3	4.4.6-1	Revision 0
4.4.1-45	Revision 3	4.4.7-1	Revision 3
4.4.1-46	Revision 3	4.5-1	Revision 3
4.4.1-47	Revision 3	4.5-2	Revision 3
4.4.1-48	Revision 3	4.5-3	Amendment 2
4.4.1-49	Revision 3	4.5-4	Amendment 2
4.4.2-1	Revision 0	4.5-5	Revision 3
4.4.3-1	Revision 3	4.5-6	Amendment 2
4.4.3-2	Revision 3	4.5-7	Revision 3
4.4.3-3	Revision 3	4.5-8	Revision 3
4.4.3-4	Revision 3	4.5-9	Revision 3
4.4.3-5	Revision 3	4.5-10	Revision 3
4.4.3-6	Revision 3	4.5-11	Amendment 2
4.4.3-7	Revision 3	4.5-12	Amendment 2
4.4.3-8	Revision 3	4.5-13	Amendment 2
4.4.3-9	Revision 3	4.5-14	Amendment 2
4.4.3-10	Revision 3	4.5-15	Amendment 2
4.4.3-11	Revision 3	4.5-16	Amendment 2
4.4.3-12	Revision 3	4.5-17	Revision 3
4.4.3-13	Revision 3	4.5-18	Revision 3
4.4.3-14	Revision 3	4.5-19	Revision 3

List of Effective Pages (continued)

4.6-1	Revision 3	5.2-10	Revision 0
4.6-2	Revision 3	5.2-11	Revision 3
4.6-3	Revision 0	5.2-12	Revision 0
4.6-4	Revision 3	5.2-13	Revision 3
Chapter 5			
5-i	Revision 3	5.2-14	Revision 3
5-ii	Revision 3	5.2-15	Revision 3
5-iii	Revision 3	5.2-16	Revision 3
5-iv	Revision 3	5.2-17	Revision 3
5-v	Revision 3	5.2-18	Revision 3
5-vi	Revision 3	5.2-19	Revision 3
5-vii.....	Revision 3	5.2-20	Revision 3
5-viii.....	Revision 3	5.2-21	Revision 3
5-ix	Revision 3	5.2-22	Revision 3
5.1-1	Revision 3	5.2-23	Revision 0
5.1-2.....	Revision 3	5.2-24	Revision 0
5.1-3.....	Revision 3	5.2-25	Revision 0
5.1-4.....	Revision 3	5.2-26	Revision 0
5.1-5.....	Revision 3	5.2-27	Revision 0
5.1-6.....	Revision 3	5.2-28	Revision 3
5.1-7.....	Revision 3	5.2-29	Revision 3
5.1-8.....	Revision 3	5.2-30	Revision 0
5.1-9.....	Revision 3	5.2-31	Revision 0
5.1-10.....	Revision 3	5.2-32	Revision 3
5.1-11.....	Revision 3	5.2-33	Revision 3
5.2-1	Revision 3	5.2-34	Revision 3
5.2-2.....	Revision 3	5.2-35	Revision 3
5.2-3.....	Revision 3	5.3-1	Revision 3
5.2-4.....	Revision 3	5.3-2	Revision 3
5.2-5.....	Revision 3	5.3-3	Revision 3
5.2-6.....	Revision 3	5.3-4	Revision 3
5.2-7.....	Revision 3	5.3-5	Revision 3
5.2-8.....	Revision 3	5.3-6	Revision 3
5.2-9.....	Revision 0	5.3-7	Revision 3
		5.3-8	Revision 3
		5.3-9	Revision 3

List of Effective Pages (continued)

5.3-10	Revision 3	5.4-13	Revision 3
5.3-11	Revision 3	5.4-14	Revision 3
5.3-12	Revision 3	5.4-15	Revision 3
5.3-13	Revision 3	5.4-16	Revision 3
5.3-14	Revision 3	5.4-17	Revision 3
5.3-15	Revision 3	5.4-18	Revision 3
5.3-16	Revision 3	5.4-19	Revision 3
5.3-17	Revision 3	5.4-20	Revision 3
5.3-18	Revision 3	5.4-21	Revision 3
5.3-19	Revision 3	5.4-22	Revision 3
5.3-20	Revision 3	5.4-23	Revision 3
5.3-21	Revision 3	5.4-24	Revision 3
5.3-22	Revision 3	5.4-25	Revision 3
5.3-23	Revision 3	5.4-26	Revision 3
5.3-24	Revision 3	5.4-27	Revision 3
5.3-25	Revision 3	5.5-1	Revision 3
5.3-26	Revision 3	5.5-2	Revision 3
5.3-27	Revision 3	5.5-3	Revision 3
5.3-28	Revision 3	5.5-4	Revision 3
5.3-29	Revision 3	5.5-5	Revision 3
5.3-30	Revision 3	5.5-6	Revision 3
5.3-31	Revision 3	5.5-7	Revision 3
5.3-32	Revision 3	5.5-8	Revision 3
5.4-1	Revision 3	5.5-9	Revision 3
5.4-2	Revision 3	5.6-1	Amendment 1
5.4-3	Revision 3	5.6.1-1	Revision 3
5.4-4	Revision 3	5.6.1-2	Amendment 1
5.4-5	Revision 3	5.6.1-3	Amendment 1
5.4-6	Revision 3	5.6.1-4	Amendment 1
5.4-7	Revision 3	5.6.1-5	Amendment 1
5.4-8	Revision 3	5.6.1-6	Revision 3
5.4-9	Revision 3	5.6.1-7	Revision 3
5.4-10	Revision 3	5.6.1-8	Revision 3
5.4-11	Revision 3	5.6.1-9	Amendment 1
5.4-12	Revision 3	5.6.1-10	Amendment 1

List of Effective Pages (continued)

5.6.1-11	Revision 3	6-vii	Revision 3
5.6.1-12	Revision 3	6.1-1	Revision 3
5.6.1-13	Amendment 2	6.1-2	Revision 3
5.6.1-14	Amendment 2	6.1-3	Revision 3
5.6.1-15	Amendment 2	6.1-4	Revision 3
5.6.1-16	Amendment 2	6.1-5	Revision 3
5.6.1-17	Amendment 2	6.1-6	Revision 3
5.6.1-18	Amendment 2	6.2-1	Revision 3
5.6.1-19	Amendment 2	6.2-2	Revision 3
5.6.1-20	Amendment 2	6.2-3	Revision 3
5.6.1-21	Amendment 2	6.3-1	Revision 3
5.6.1-22	Amendment 2	6.3-2	Revision 3
5.6.1-23	Revision 3	6.3-3	Revision 3
5.6.1-24	Revision 3	6.3-4	Revision 3
5.6.1-25	Amendment 2	6.3-5	Revision 3
5.6.1-26	Revision 3	6.3-6	Revision 3
5.6.1-27	Revision 3	6.3-7	Revision 3
5.6.1-28	Amendment 2	6.3-8	Revision 3
5.6.1-29	Amendment 2	6.3-9	Revision 3
5.6.1-30	Amendment 2	6.3-10	Revision 3
5.6.1-31	Amendment 2	6.3-11	Revision 3
5.6.1-32	Amendment 2	6.3-12	Revision 3
5.6.1-33	Amendment 2	6.3-13	Revision 3
5.6.1-34	Amendment 2	6.3-14	Revision 3
5.7-1	Revision 0	6.3-15	Revision 3
5.7-2	Revision 0	6.3-16	Revision 3
5.7-3	Revision 3	6.3-17	Revision 3
		6.3-18	Revision 3
		6.4-1	Revision 3
		6.4-2	Revision 3
		6.4-3	Revision 3
		6.4-4	Revision 3
		6.4-5	Revision 3
		6.4-6	Revision 3
		6.4-7	Revision 3
Chapter 6			
6-i	Revision 3		
6-ii	Revision 3		
6-iii	Revision 3		
6-iv	Revision 3		
6-v	Revision 3		
6-vi	Revision 3		

List of Effective Pages (continued)

6.4-8	Revision 3	6.5-3	Revision 3
6.4-9	Revision 3	6.5-4	Revision 3
6.4-10	Revision 3	6.5-5	Revision 3
6.4-11	Revision 3	6.5-6	Revision 3
6.4-12	Revision 3	6.5-7	Revision 3
6.4-13	Revision 3	6.5-8	Revision 3
6.4-14	Revision 3	6.5-9	Revision 3
6.4-15	Revision 3	6.5-10	Revision 3
6.4-16	Revision 3	6.5-11	Revision 3
6.4-17	Revision 0	6.5-12	Revision 3
6.4-18	Revision 3	6.5-13	Revision 3
6.4-19	Revision 3	6.5-14	Revision 3
6.4-20	Revision 3	6.5-15	Revision 3
6.4-21	Revision 3	6.5-16	Revision 3
6.4-22	Revision 3	6.5-17	Revision 3
6.4-23	Revision 3	6.5-18	Revision 3
6.4-24	Revision 3	6.5-19	Revision 3
6.4-25	Revision 3	6.5-20	Revision 3
6.4-26	Revision 3	6.5-21	Revision 3
6.4-27	Revision 3	6.5-22	Revision 3
6.4-28	Revision 3	6.5-23	Revision 3
6.4-29	Revision 3	6.5-24	Revision 3
6.4-30	Revision 3	6.5-25	Revision 3
6.4-31	Revision 3	6.5-26	Revision 3
6.4-32	Revision 3	6.5-27	Revision 3
6.4-33	Revision 3	6.5-28	Revision 3
6.4-34	Revision 3	6.5-29	Revision 3
6.4-35	Revision 3	6.5-30	Revision 3
6.4-36	Revision 3	6.5-31	Revision 3
6.4-37	Revision 3	6.5-32	Revision 3
6.4-38	Revision 3	6.5-33	Revision 3
6.4-39	Revision 3	6.5-34	Revision 3
6.4-40	Revision 3	6.5-35	Revision 3
6.5-1	Revision 3	6.5-36	Revision 3
6.5-2	Revision 3	6.5-37	Revision 3

List of Effective Pages (continued)

6.5-38.....	Revision 3	6.6.1-23	Amendment 2
6.5-39.....	Revision 3	6.6.1-24	Amendment 2
6.5-40.....	Revision 3	6.7-1	Revision 0
6.5-41	Revision 3	6.7-2	Revision 3
6.5-42.....	Revision 3	6.8-1	Revision 3
6.5-43	Revision 3	6.8-2	Revision 0
6.5-44.....	Revision 3	6.8-3	Revision 0
6.5-45.....	Revision 3	6.8-4	Revision 0
6.5-46.....	Revision 3	6.8-5	Revision 0
6.5-47	Revision 3	6.8-6	Revision 0
6.5-48.....	Revision 3	6.8-7	Revision 0
6.5-49.....	Revision 3	6.8-8	Revision 0
6.6-1	Amendment 2	6.8-9	Revision 0
6.6.1-1	Amendment 2	6.8-10	Revision 0
6.6.1-2	Amendment 2	6.8-11	Revision 0
6.6.1-3	Amendment 2	6.8-12	Revision 0
6.6.1-4	Amendment 2	6.8-13	Revision 0
6.6.1-5	Revision 3	6.8-14	Revision 0
6.6.1-6.....	Amendment 2	6.8-15	Revision 0
6.6.1-7	Revision 3	6.8-16	Revision 0
6.6.1-8.....	Revision 3	6.8-17	Revision 0
6.6.1-9	Amendment 2	6.8-18	Revision 0
6.6.1-10.....	Amendment 2	6.8-19	Revision 0
6.6.1-11	Revision 3	6.8-20	Revision 0
6.6.1-12.....	Amendment 2	6.8-21	Revision 0
6.6.1-13	Amendment 2	6.8-22	Revision 0
6.6.1-14	Amendment 2	6.8-23	Revision 0
6.6.1-15	Amendment 2	6.8-24	Revision 0
6.6.1-16.....	Amendment 2	6.8-25	Revision 0
6.6.1-17	Amendment 2	6.8-26	Revision 0
6.6.1-18.....	Amendment 2	6.8-27	Revision 0
6.6.1-19	Amendment 2	6.8-28	Revision 0
6.6.1-20.....	Amendment 2	6.8-29	Revision 0
6.6.1-21	Amendment 2	6.8-30	Revision 0
6.6.1-22.....	Revision 3	6.8-31	Revision 0

List of Effective Pages (continued)

6.8-32 Revision 0
6.8-33 Revision 0
6.8-34 Revision 0
6.8-35 Revision 0
6.8-36 Revision 0
6.8-37 Revision 0
6.8-38 Revision 0
6.8-39 Revision 0
6.8-40 Revision 0
6.8-41 Revision 0
6.8-42 Revision 0
6.8-43 Revision 0
6.8-44 Revision 0
6.8-45 Revision 0
6.8-46 Revision 0
6.8-47 Revision 0
6.8-48 Revision 0
6.8-49 Revision 0
6.8-50 Revision 0
6.8-51 Revision 0
6.8-52 Revision 3
6.8-53 Revision 3
6.8-54 Revision 3
6.8-55 Revision 3
6.8-56 Revision 3
6.8-57 Revision 3
6.8-58 Revision 3
6.8-59 Revision 3
6.8-60 Revision 3
6.8-61 Revision 3
6.8-62 Revision 3
6.8-63 Revision 3
6.8-64 Revision 3
6.8-65 Revision 3
6.8-66 Revision 3

Chapter 7

7-i Amendment 1
7-ii Revision 0
7.1-1 Revision 3
7.1-2 Revision 3
7.1-3 Revision 3
7.1-4 Revision 3
7.1-5 Revision 3
7.1-6 Revision 3
7.1-7 Revision 3
7.1-8 Revision 3
7.1-9 Revision 3
7.1-10 Revision 3
7.1-11 Revision 0
7.2-1 Revision 3
7.2-2 Revision 0
7.3-1 Revision 0
7.4-1 Revision 3
7.5-1 Amendment 2

Chapter 8

8-i Amendment 1
8-ii Revision 3
8-1 Revision 3
8-2 Revision 3
8.1-1 Revision 3
8.1.1-1 Revision 3
8.1.1-2 Revision 3
8.1.1-3 Revision 3
8.1.1-4 Revision 3
8.1.1-5 Revision 3
8.1.1-6 Revision 3
8.1.1-7 Revision 3
8.1.1-8 Revision 3
8.1.1-9 Revision 3

List of Effective Pages (continued)

8.1.1-10	Revision 3	10.1-2	Revision 3
8.1.2-1	Revision 3	10.2-1	Revision 3
8.1.2-2	Revision 3	10.2-2	Revision 3
8.1.3-1	Revision 3	10.3-1	Revision 3
8.1.3-2	Revision 3	10.3-2	Revision 3
8.2-1	Amendment 2	10.3-3	Revision 3
8.2-2	Revision 3	10.3-4	Revision 0
8.3-1	Revision 3	10.3-5	Revision 3
8.3-2	Revision 3	10.3-6	Revision 3
8.3-3	Revision 3	10.3-7	Revision 0
8.3-4	Revision 3	10.3-8	Revision 3
8.4-1	Revision 0	10.3-9	Revision 3

Chapter 9

9-i	Revision 3
9.1-1	Revision 3
9.1-2	Revision 3
9.1-3	Revision 3
9.1-4	Revision 3
9.1-5	Revision 3
9.1-6	Revision 3
9.1-7	Revision 3
9.1-8	Revision 3
9.1-9	Revision 3
9.1-10	Revision 3
9.1-11	Revision 3
9.2-1	Revision 3
9.2-2	Revision 3
9.3-1	Revision 3

Chapter 10

10-i	Amendment 1
10-ii	Revision 3
10.1-1	Revision 3

10.4-1	Revision 3
10.4-2	Revision 3
10.4-3	Revision 3
10.4-4	Revision 3
10.4-5	Revision 3
10.5-1	Amendment 1
10.6-1	Revision 0

Chapter 11

11-i	Amendment 1
11-ii	Revision 3
11-iii	Revision 3
11-iv	Revision 3
11-v	Revision 3
11-vi	Revision 3
11-vii	Revision 3
11-viii	Revision 3
11-ix	Revision 3
11-x	Revision 3
11-1	Revision 0
11.1.1-1	Revision 0
11.1.1-2	Revision 3
11.1.1-3	Revision 0

List of Effective Pages (continued)

11.1.1-4.....	Revision 0	11.2.2-1	Revision 0
11.1.1-5.....	Revision 0	11.2.3-1	Revision 3
11.1.1-6.....	Revision 0	11.2.3-2	Revision 0
11.1.2-1.....	Revision 3	11.2.4-1	Revision 3
11.1.2-2.....	Revision 0	11.2.4-2	Revision 3
11.1.2-3.....	Revision 3	11.2.4-3	Revision 3
11.1.3-1.....	Revision 3	11.2.4-4	Revision 3
11.1.3-2.....	Revision 3	11.2.4-5	Revision 3
11.1.3-3.....	Revision 3	11.2.4-6	Revision 3
11.1.3-4.....	Revision 3	11.2.4-7	Revision 3
11.1.3-5.....	Revision 3	11.2.4-8	Revision 3
11.1.3-6.....	Revision 3	11.2.4-9	Revision 3
11.1.3-7.....	Revision 3	11.2.4-10.....	Revision 3
11.1.3-8.....	Revision 3	11.2.4-11.....	Revision 3
11.1.3-9.....	Revision 3	11.2.4-12.....	Revision 0
11.1.3-10.....	Revision 3	11.2.4-13.....	Revision 0
11.1.3-11.....	Revision 3	11.2.4-14.....	Revision 0
11.1.3-12.....	Revision 3	11.2.4-15.....	Revision 0
11.1.3-13.....	Revision 3	11.2.4-16.....	Revision 0
11.1.3-14.....	Revision 3	11.2.4-17.....	Revision 0
11.1.3-15.....	Revision 3	11.2.4-18.....	Revision 0
11.1.3-16.....	Revision 3	11.2.4-19.....	Revision 0
11.1.4-1.....	Amendment 1	11.2.4-20.....	Revision 0
11.1.4-2.....	Revision 0	11.2.4-21.....	Revision 0
11.1.5-1.....	Revision 0	11.2.4-22.....	Revision 3
11.1.5-2.....	Revision 0	11.2.4-23.....	Revision 3
11.1.6-1.....	Amendment 1	11.2.4-24.....	Revision 3
11.2-1.....	Amendment 1	11.2.4-25.....	Revision 3
11.2.1-1.....	Revision 3	11.2.4-26.....	Revision 3
11.2.1-2.....	Revision 3	11.2.4-27.....	Revision 3
11.2.1-3.....	Revision 3	11.2.5-1.....	Revision 0
11.2.1-4.....	Revision 3	11.2.6-1.....	Revision 3
11.2.1-5.....	Revision 3	11.2.6-2.....	Revision 3
11.2.1-6.....	Revision 3	11.2.6-3.....	Amendment 2
11.2.1-7.....	Revision 3	11.2.6-4.....	Revision 0

List of Effective Pages (continued)

11.2.6-5	Revision 3	11.2.11-13	Revision 0
11.2.7-1	Revision 3	11.2.11-14	Revision 3
11.2.7-2	Revision 3	11.2.12-1	Revision 0
11.2.8-1	Revision 3	11.2.12-2	Revision 3
11.2.8-2	Revision 0	11.2.12-3	Revision 3
11.2.8-3	Revision 3	11.2.12-4	Revision 3
11.2.8-4	Revision 3	11.2.12-5	Revision 3
11.2.8-5	Revision 3	11.2.12-6	Revision 3
11.2.8-6	Revision 3	11.2.12-7	Revision 3
11.2.8-7	Revision 3	11.2.12-8	Revision 3
11.2.8-8	Revision 3	11.2.12-9	Revision 3
11.2.8-9	Revision 3	11.2.12-10	Revision 3
11.2.9-1	Revision 0	11.2.12-11	Revision 0
11.2.9-2	Revision 3	11.2.12-12	Revision 0
11.2.9-3	Revision 3	11.2.12-13	Revision 3
11.2.9-4	Revision 3	11.2.12-14	Revision 3
11.2.9-5	Revision 3	11.2.12-15	Revision 3
11.2.9-6	Revision 3	11.2.12-16	Revision 0
11.2.9-7	Revision 3	11.2.12-17	Revision 0
11.2.10-1	Revision 0	11.2.12-18	Revision 0
11.2.10-2	Revision 0	11.2.12-19	Revision 3
11.2.10-3	Revision 0	11.2.12-20	Revision 3
11.2.10-4	Revision 0	11.2.12-21	Revision 0
11.2.11-1	Revision 0	11.2.12-22	Revision 3
11.2.11-2	Revision 3	11.2.12-23	Revision 0
11.2.11-3	Revision 3	11.2.12-24	Revision 3
11.2.11-4	Revision 3	11.2.12-25	Revision 3
11.2.11-5	Revision 0	11.2.12-26	Revision 3
11.2.11-6	Revision 0	11.2.12-27	Revision 3
11.2.11-7	Revision 0	11.2.12-28	Revision 3
11.2.11-8	Revision 3	11.2.12-29	Revision 3
11.2.11-9	Revision 3	11.2.12-30	Revision 3
11.2.11-10	Revision 3	11.2.12-31	Revision 3
11.2.11-11	Revision 3	11.2.12-32	Revision 3
11.2.11-12	Revision 0	11.2.12-33	Revision 3

List of Effective Pages (continued)

11.2.12-34	Revision 3	11.2.12-69	Revision 3
11.2.12-35	Revision 3	11.2.12-70	Revision 3
11.2.12-36	Revision 3	11.2.12-71	Revision 3
11.2.12-37	Revision 3	11.2.13-1	Revision 0
11.2.12-38	Revision 3	11.2.13-2	Revision 3
11.2.12-39	Revision 3	11.2.13-3	Revision 0
11.2.12-40	Revision 3	11.2.14-1	Revision 3
11.2.12-41	Revision 3	11.2.14-2	Revision 3
11.2.12-42	Revision 3	11.2.15-1	Revision 3
11.2.12-43	Revision 3	11.2.15-2	Revision 3
11.2.12-44	Revision 3	11.2.15-3	Amendment 1
11.2.12-45	Revision 3	11.2.15-4	Amendment 2
11.2.12-46	Revision 3	11.2.15-5	Amendment 2
11.2.12-47	Revision 3	11.2.15-6	Amendment 1
11.2.12-48	Revision 3	11.2.15-7	Amendment 1
11.2.12-49	Revision 3	11.2.15-8	Amendment 1
11.2.12-50	Revision 3	11.2.15-9	Amendment 1
11.2.12-51	Revision 3	11.2.15-10	Amendment 1
11.2.12-52	Revision 3	11.2.15-11	Amendment 1
11.2.12-53	Revision 3	11.2.15-12	Amendment 1
11.2.12-54	Revision 3	11.2.15-13	Amendment 1
11.2.12-55	Revision 3	11.2.15-14	Revision 3
11.2.12-56	Revision 3	11.2.15-15	Revision 3
11.2.12-57	Revision 3	11.2.15-16	Revision 3
11.2.12-58	Revision 3	11.2.15-17	Revision 3
11.2.12-59	Revision 3	11.2.15-18	Amendment 1
11.2.12-60	Revision 3	11.2.15-19	Amendment 1
11.2.12-61	Revision 3	11.2.15-20	Amendment 1
11.2.12-62	Revision 3	11.2.15-21	Amendment 1
11.2.12-63	Revision 3	11.2.15-22	Amendment 1
11.2.12-64	Revision 3	11.2.15-23	Amendment 2
11.2.12-65	Revision 3	11.2.15-24	Amendment 2
11.2.12-66	Revision 3	11.2.15-25	Amendment 2
11.2.12-67	Revision 3	11.2.15-26	Amendment 2
11.2.12-68	Revision 3	11.2.15-27	Amendment 1

List of Effective Pages (continued)

11.2.15-28	Amendment 2	12C3-5.....	Revision 0
11.2.15-29	Amendment 2	12C3-6.....	Revision 0
11.2.15-30	Revision 3	12C3-7.....	Revision 0
11.2.15-31	Revision 3	12C3-8.....	Revision 0
11.2.15-32	Amendment 2	12C3-9.....	Revision 3
11.2.15-33	Amendment 2	12C3-10.....	Revision 3
11.2.15-34	Amendment 2	12C3-11.....	Revision 3
11.2.15-35	Amendment 2	12C3-12.....	Revision 3
11.3-1	Revision 3	12C3-13.....	Revision 0
11.3-2	Revision 0	12C3-14.....	Revision 3
11.3-3	Revision 0	12C3-15.....	Revision 3
11.3-4	Revision 3	12C3-16.....	Revision 0
11.3-5	Revision 3	12C3-17.....	Revision 3
		12C3-18.....	Revision 3
		12C3-19.....	Revision 3
		12C3-20.....	Revision 3
		12C3-21.....	Revision 3
		12C3-22.....	Revision 3
		12C3-23.....	Revision 3
		12C3-24.....	Revision 3
		12C3-25.....	Revision 3
		12C3-26.....	Revision 3
		12C3-27.....	Revision 3
		12C3-28.....	Revision 3
		12C3-29.....	Revision 3
		12C3-30.....	Revision 3
		12C3-31.....	Revision 3
		12C3-32.....	Revision 3
		12C3-33.....	Revision 3
		12C3-34.....	Revision 3
		12C3-35.....	Revision 3
		12C3-36.....	Revision 3
		12C3-37.....	Revision 3
		12C3-38.....	Revision 3

Chapter 12

12-i	Amendment 1
12-ii.....	Amendment 1
12-1	Revision 3
12-2	Revision 3
12-3	Revision 3
12-4	Revision 3
12A-1	Revision 3
12A-2	Revision 3
12B-1	Revision 3
12B-2	Revision 3
12C-1	Revision 0
12C-2	Revision 3
12C1-1	Revision 3
12C2-1	Revision 3
12C2-2	Revision 3
12C3-1	Revision 0
12C3-2	Revision 0
12C3-3	Revision 0
12C3-4	Revision 0

List of Effective Pages (continued)

Chapter 13

13-i	Revision 0
13-ii.....	Revision 0
13.1-1	Revision 0
13.1-2.....	Revision 0
13.2-1	Revision 0
13.2-2.....	Revision 0
13.2-3	Revision 0
13.2-4.....	Revision 0
13.2-5.....	Revision 0
13.2-6.....	Revision 0
13.2-7	Revision 0
13.2-8.....	Revision 3
13.3-1	Revision 3

Table of Contents

1.0	GENERAL DESCRIPTION.....	1-1
1.1	Introduction.....	1.1-1
1.2	General Description of the Universal Storage System	1.2-1
1.2.1	Universal Storage System Components.....	1.2-1
1.2.1.1	Transportable Storage Canister.....	1.2-2
1.2.1.2	Fuel Baskets	1.2-3
1.2.1.3	Vertical Concrete Cask	1.2-6
1.2.1.4	Transfer Cask.....	1.2-7
1.2.1.5	Auxiliary Equipment.....	1.2-9
1.2.1.6	Universal Transport Cask	1.2-11
1.2.2	Operational Features	1.2-12
1.3	Universal Storage System Contents.....	1.3-1
1.3.1	Design Basis Spent Fuel	1.3-1
1.3.2	Site Specific Spent Fuel.....	1.3-2
1.3.2.1	Maine Yankee Site Specific Spent Fuel.....	1.3-3
1.4	Generic Vertical Concrete Cask Arrays.....	1.4-1
1.5	UMS® Universal Storage System Compliance with NUREG-1536.....	1.5-1
1.6	Identification of Agents and Contractors	1.6-1
1.7	References.....	1.7-1
1.8	License Drawings.....	1.8-1
1.8.1	License Drawings for the UMS® Universal Storage System.....	1.8-1
1.8.2	Site Specific Spent Fuel License Drawings	1.8-2

List of Figures

Figure 1.1-1	Major Components of the Universal Storage System (in Vertical Concrete Cask Loading Configuration).....	1.1-3
Figure 1.1-2	Transportable Storage Canister Containing PWR Spent Fuel Basket	1.1-4
Figure 1.1-3	Transportable Storage Canister Containing BWR Spent Fuel Basket.....	1.1-4
Figure 1.2-1	Vertical Concrete Cask	1.2-14
Figure 1.2-2	Transfer Cask.....	1.2-15
Figure 1.2-3	Transport Configuration of the Universal Transport Cask	1.2-16
Figure 1.2-4	Transfer Cask and Canister Arrangement.....	1.2-17
Figure 1.2-5	Vertical Concrete Cask and Transfer Cask Arrangement.....	1.2-18
Figure 1.2-6	Major Component Configuration for Loading the Vertical Concrete Cask ...	1.2-19
Figure 1.4-1	Typical ISFSI Storage Pad Layout	1.4-2

List of Tables

Table 1-1	Terminology.....	1-3
Table 1.2-1	Design Characteristics of the UMS® Universal Storage System.....	1.2-20
Table 1.2-2	Major Physical Design Parameters of the Transportable Storage Canister	1.2-23
Table 1.2-3	Transportable Storage Canister Fabrication Specification Summary	1.2-24
Table 1.2-4	Major Physical Design Parameters of the Fuel Basket.....	1.2-25
Table 1.2-5	Major Physical Design Parameters of the Vertical Concrete Cask.....	1.2-26
Table 1.2-6	Vertical Concrete Cask Fabrication Specification Summary	1.2-27
Table 1.2-7	Major Physical Design Parameters of the Transfer Casks.....	1.2-28
Table 1.5-1	NUREG-1536 Compliance Matrix	1.5-2

1.0 GENERAL DESCRIPTION

NAC International Inc. (NAC) has designed a canister-based system for the storage and transportation of spent nuclear fuel. The system is designated the Universal MPC System[®] (UMS[®]). The storage component of the UMS[®] is designated the Universal Storage System. This Safety Analysis Report (SAR) demonstrates the ability of the Universal Storage System to satisfy the requirements of the U.S. Nuclear Regulatory Commission (NRC) for the storage of spent nuclear fuel as prescribed in Title 10 of the Code of Federal Regulations, Part 72 (10 CFR 72) [1], and NUREG-1536 [2]. The transportation component of the UMS[®] is designated the Universal Transportation System, which is addressed in the NAC Safety Analysis Report for the Universal Transport Cask, Docket No. 71-9270 [3].

The Universal Storage System primary components consist of the Transportable Storage Canister, Vertical Concrete Cask, and a transfer cask. The Transportable Storage Canister is designed and fabricated to meet the requirements for transport in the Universal Transport Cask (part of the Universal Transportation System) and to be compatible with the U.S. Department of Energy (DOE) MPC Design Procurement Specification [4], so as not to preclude the possibility of permanent disposal in a deep Mined Geological Disposal System.

In long-term storage, the Transportable Storage Canister is installed in a Vertical Concrete Cask, which provides passive radiation shielding and natural convection cooling. The Vertical Concrete Cask also provides protection during storage for the Transportable Storage Canister under adverse environmental conditions. The cask employs a double-welded closure design to preclude loss of contents and to preserve the general health and safety of the public during long-term storage of spent fuel.

The transfer cask is used to move the Transportable Storage Canister from the work stations where the canister is loaded and closed to the Vertical Concrete Cask. It is also used to transfer the canister from the Vertical Concrete Cask to the Universal Transport Cask for transport.

This Safety Analysis Report is formatted in accordance with U.S. NRC Regulatory Guide 3.61 [5]. This chapter provides a general description of the major components of the Universal Storage System and a description of system operation. Definition of terminology used throughout this report is summarized in Table 1-1. The term “concrete cask” or “cask” is routinely used to refer to the Vertical Concrete Cask. The term “Transportable Storage Canister” or “canister” is used to refer to both the PWR and BWR canisters where the discussion is

common to both configurations. Discussion of features unique to each of the PWR and BWR configurations is handled in subsections, as appropriate, within each chapter.

Table 1.5-1 provides a compliance matrix to the regulatory requirements and acceptance criteria specified in NUREG-1536. This matrix describes how the Universal Storage System Safety Analysis Report addresses and demonstrates compliance with each requirement and criterion listed in NUREG-1536. Table B3-1 in Appendix B of the Amendment 3 Technical Specifications provides a list of the exceptions to the American Society of Mechanical Engineers (ASME) Boiler and Pressure Vessel Code.

Table 1-1 Terminology

Universal Storage System	The storage component of the Universal MPC System (UMS [®]) designed by NAC for the storage and transportation of spent nuclear fuel.
Universal Transport Cask	The packaging consisting of a Universal Transport Cask body with a closure lid and energy-absorbing impact limiters. The Universal Transport Cask is used to transport a Transportable Storage Canister containing spent fuel. The cask body provides the primary containment boundary during transport.
Confinement System	The components of the Transportable Storage Canister intended to retain the radioactive material during storage.
Contents	Twenty-four PWR fuel assemblies, or fifty-six BWR fuel assemblies. The fuel assemblies may be configured as Site Specific Fuel. The fuel assemblies are contained in a Transportable Storage Canister.
Standard Fuel	<p>Irradiated fuel assemblies with a burnup less than, or equal to, 45,000 MWD/MTU and having the same configuration as when originally fabricated consisting generally of the end fittings, fuel rods, guide tubes, and integral hardware. For PWR fuel, a flow mixer, an in-core instrument thimble or a burnable poison rod insert is considered to be a component of standard fuel. For BWR fuel, the channel is considered to be integral hardware.</p> <p>The design basis fuel characteristics and analysis are based on the standard fuel configuration.</p>
Consolidated Fuel	A nonstandard fuel configuration in which the individual intact fuel rods from one or more fuel assemblies are placed in a single container or a lattice structure that is dimensionally similar to a fuel assembly. Consolidated Fuel is stored in a Maine Yankee Fuel Can.
Intact Fuel (Assembly or Rod) (Undamaged Fuel)	A fuel assembly or fuel rod with no fuel rod cladding defects, or with known or suspected fuel rod cladding defects not greater than pinhole leaks or hairline cracks.

Table 1-1 Terminology (Continued)

**Damaged Fuel
(Failed Fuel)** A fuel assembly or fuel rod with known or suspected cladding defects greater than pinhole leaks or hairline cracks.

Damaged Fuel must be placed in a Maine Yankee Fuel Can.

High Burnup Fuel A fuel assembly having a burnup between 45,000 and 50,000 MWD/MTU, which must be preferentially loaded in peripheral positions of the basket.

Table 1-1 Terminology (Continued)

Site Specific Fuel	<p>Spent fuel configurations that are unique to a site or reactor due to the addition of other components or reconfiguration of the fuel assembly at the site. It includes fuel assemblies, which hold nonfuel-bearing components, such as control components or instrument and plug thimbles, or which are modified as required by expediency in reactor operations, research and development or testing. Modification may consist of individual fuel rod removal, fuel rod replacement of similar or dissimilar material or enrichment, the installation, removal or replacement of burnable poison rods, or containerizing damaged (failed) fuel.</p> <p>Site specific fuel includes irradiated fuel assemblies designed with variable enrichments and/or axial blankets, fuel that is consolidated and fuel that exceeds design basis fuel parameters.</p>
Maine Yankee Fuel Can	<p>A specially designed stainless steel screened can sized to hold an intact fuel assembly, consolidated fuel, or damaged fuel. The can screens permit draining and drying, while precluding the release of gross particulates into the canister cavity. The Maine Yankee Fuel Can may only be loaded in a Class 1 Canister.</p>
Transportable Storage Canister (Canister)	<p>The stainless steel cylindrical shell, bottom end plate, shield lid, and structural lid that contain the fuel basket structure and the contents.</p>
Shield Lid	<p>A thick stainless steel disk that is located directly above the fuel basket. The shield lid comprises the first part of a double-welded closure system for the Transportable Storage Canister. The shield lid provides a containment/confinement boundary for storage and shielding for the contents.</p>
- Drain Port	<p>A penetration located in the shield lid to permit draining of the canister cavity.</p>
- Vent Port	<p>A penetration located in the shield lid to aid in draining and in vacuum drying and backfilling the canister with helium.</p>

Table 1-1 Terminology (Continued)

- **Port Cover** The stainless steel covers that close the vent and drain ports, and that are welded in place following draining, drying, and backfilling operations.
- **Quick Disconnect** The valved nipple used in the vent and drain ports to facilitate operations.

Structural Lid A thick stainless steel disk that is positioned on top of the shield lid and welded to the canister. The structural lid is the second part of a double-welded closure system for the Transportable Storage Canister. The structural lid provides a confinement boundary for storage, shielding for the contents, and canister lifting/handling capability.

Fuel Basket (Basket) The structure located within the Transportable Storage Canister that provides structural support, criticality control, and primary heat transfer paths for the fuel assemblies.

- **Support Disk** The primary lateral load-bearing component of the fuel basket. The PWR support disk is a circular stainless steel plate with 24 square holes machined in a symmetrical pattern. The BWR support disk is a circular carbon steel plate with 56 square holes machined in a symmetrical pattern. Each square hole is a location for a fuel tube.

- **Heat Transfer Disk** A circular aluminum plate with 24 (PWR basket) or 56 (BWR basket) square holes machined in a symmetrical pattern. The heat transfer disk enhances heat transfer in the fuel basket.

- **Fuel Tube** A stainless steel tube having a square cross-section. One fuel tube is inserted through each square hole in the support disks and heat transfer disks. Fuel assemblies are loaded into the fuel tubes. A fuel tube may have neutron absorber material enclosed by a stainless steel sheet on one or more of its external faces, depending on fuel type and the position of the fuel tube in the basket.

Table 1-1 Terminology (Continued)

- Tie Rod	A stainless steel rod used to align, retain, and support the support disks and the heat transfer disks in the fuel basket structure. The tie rods extend from the top weldment to the bottom weldment.
- Spacer	Installed on the tie rod between the support disks (BWR only) or between the support disks and top and bottom weldments (BWR and PWR) to properly position the disks and provide axial support for the support disks.
- Split Spacer	Spacers installed on the tie rod between the support disks and the heat transfer disks to properly position the disks and provide axial support for the support disks and the heat transfer disks.
Vertical Concrete Cask (Concrete Cask)	A concrete cylinder that contains the Transportable Storage Canister during storage. The Vertical Concrete Cask is formed around a steel inner liner and base and is closed by a shield plug and lid.
- Shield Plug	A thick carbon steel plug, which also contains a neutron shield material, installed in the top end of the Vertical Concrete Cask to reduce skyshine radiation.
- Lid	A thick carbon steel plate that serves as the bolted closure for the Vertical Concrete Cask. The lid precludes access to the canister and provides additional radiation shielding.
- Liner	A thick carbon steel shell that forms the annulus of the concrete cask. The liner serves as the inner form during concrete pouring and provides radiation shielding of the canister contents.
- Base	A carbon steel weldment that contains the air inlets, the concrete cask jacking points and the pedestal that supports the canister inside of the concrete cask.

Table 1-1 Terminology (Continued)

Transfer Cask	A shielded lifting device for handling of the Transportable Storage Canister during loading of spent fuel, canister closure operations, and transfer of the canister into or out of the Vertical Concrete Cask during storage, or into or out of the Universal Transport Cask during transportation. The transfer cask incorporates bottom doors that permit the vertical loading of the storage and transport casks. The transfer cask is provided in either the standard or the advanced configuration. The advanced configuration has a higher weight capacity.
- Transfer Cask Lifting Trunnions	Four low alloy steel trunnions used to lift and move the transfer cask in a vertical orientation.
Transfer Adapter	A carbon steel plate assembly that is positioned on to the top of the transport or concrete cask to facilitate installation and alignment of the transfer cask. It also provides the operating mechanism for the transfer cask bottom doors.
NS-4-FR or NS-3	Solid hydrogenous materials with neutron absorption capabilities.
Air Pad Rig Set (Air Pallet)	A device used to lift the Vertical Concrete Cask by using high volume air.
Heavy Haul Trailer	The trailer used to transport the empty or loaded Vertical Concrete Cask.
Margin of Safety	An analytically determined value defined as the “factor of safety” minus 1. Factor of safety is also analytically determined, and is defined as the allowable stress or displacement of a material divided by its actual (calculated) value.

1.1 Introduction

The Universal Storage System is a spent fuel dry storage system that uses a Vertical Concrete Cask and a stainless steel Transportable Storage Canister with a double welded closure to safely store spent fuel. The Transportable Storage Canister is stored in the central cavity of the Vertical Concrete Cask and is compatible with the Universal Transport Cask for future off-site shipment. The concrete cask provides radiation shielding and contains internal air flow paths that allow the decay heat from the canister contents to be removed by natural air circulation around the canister wall. The Universal Storage System is designed and analyzed for a 50-year service life.

The principal components of the Universal Storage System are the canister, the concrete cask, and the transfer cask. The loaded canister is moved to and from the concrete cask by using the transfer cask. The transfer cask provides radiation shielding while the canister is being closed and sealed and while the canister is being transferred. The canister is placed in the concrete cask by positioning the transfer cask with the loaded canister on top of the concrete cask and lowering the canister into the concrete cask. Figure 1.1-1 depicts the major components of the Universal Storage System in such a configuration.

The Universal Storage System is designed to safely store up to 24 PWR or up to 56 BWR spent fuel assemblies. The fuel specifications and parameters that serve as the design basis are presented in Tables 2.1.1-1 and 2.1.2-1 for PWR and BWR fuel assemblies, respectively. The spent fuel considered in the design basis includes fuel assemblies that have different overall lengths. The range of overall lengths of the PWR fuel assembly population is grouped into three classes. To accommodate the three classes, the Universal Storage System principal components—the transportable storage canister, transfer cask and vertical concrete cask—are provided in three different lengths. Similarly, BWR fuel assemblies are grouped into two classes, which are also accommodated by two different lengths of the principal components. The class designations of these principal components, and corresponding lengths, are shown on the License Drawings. The identification of representative fuel assemblies, by class, is shown in Tables 6.2-1 and 6.2-2 for PWR and BWR fuel, respectively. Fuel assemblies were grouped to facilitate licensing evaluations. Bounding configurations were evaluated and no restriction is placed on the loading of a given fuel assembly type into a particular UMS[®] canister class.

The inclusion of nonfuel-bearing components or fixtures in a fuel assembly can increase its overall length, resulting in the need to use the next longer class of Universal Storage System components. Stainless steel spacers may be used in a given class of canister to allow loading of fuel that is significantly shorter than the canister length. The BWR fuel assembly classes are

evaluated for the effects of the Zircaloy channel that surrounds the fuel assembly in reactor operations.

In addition to the design basis fuel, fuel that is unique to a certain reactor site, referred to as site specific fuel, is also evaluated. Site specific fuel consists of fuel assemblies that are configured differently, or have different parameters (such as enrichment or burnup), than the design basis fuel assemblies. These site specific fuel configurations result from conditions that occurred during reactor operations, from participation in research and development programs (testing programs intended to improve reactor operations), or from the insertion of control components or other items within the fuel assembly.

Site specific spent fuels are described in Section 1.3.2. These site specific fuel configurations are either shown to be bounded by the design basis fuel analysis, or are separately evaluated. Unless specifically excepted, site specific fuel must also meet the conditions for the design basis fuel presented in Section 1.3.1.

Three canister classes accommodate the PWR fuel assemblies, and two canister classes accommodate the BWR fuel assemblies. Each of the five canisters is stored in a concrete cask of specific length designed to accommodate the specific canister. The fuel is loaded into the appropriate canister prior to movement of the canister into the concrete cask. Figure 1.1-2 depicts a Transportable Storage Canister containing a PWR spent fuel basket. A canister containing a BWR spent fuel basket is shown in Figure 1.1-3.

The system design and analyses are performed in accordance with 10 CFR 72, ANSI/ANS 57.9 [6] and the applicable sections of the ASME Boiler and Pressure Vessel Code and the American Concrete Institute Code [7].

Figure 1.1-1 Major Components of the Universal Storage System (in Vertical Concrete Cask Loading Configuration)

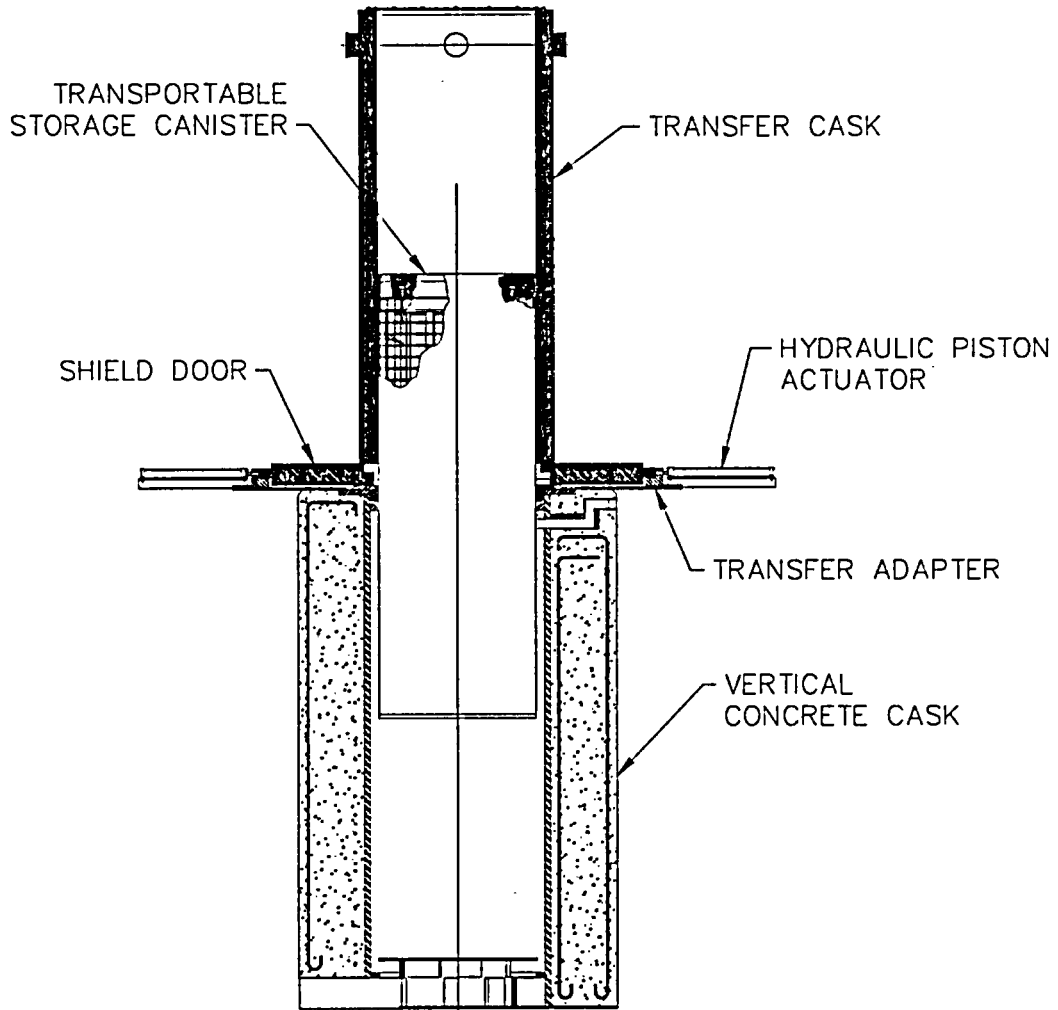

Figure 1.1-2 Transportable Storage Canister Containing PWR Spent Fuel Basket

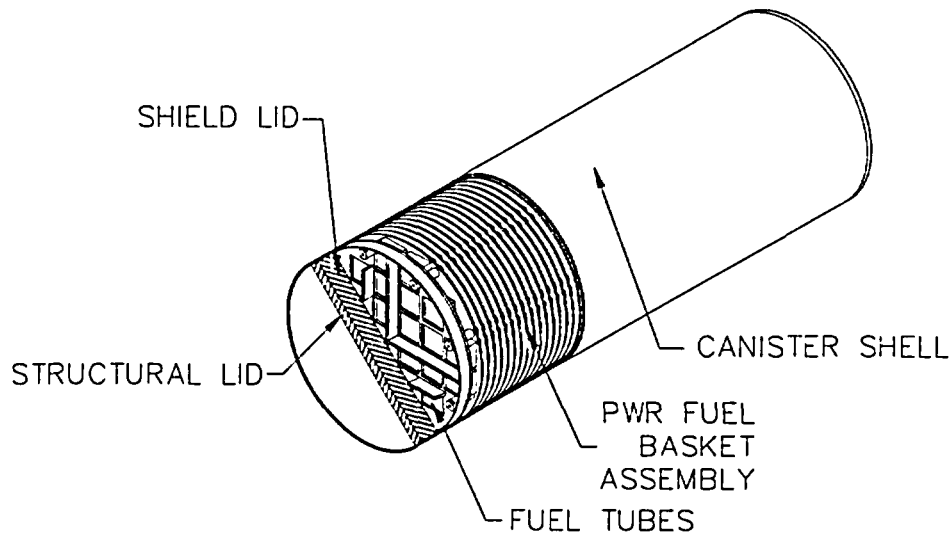
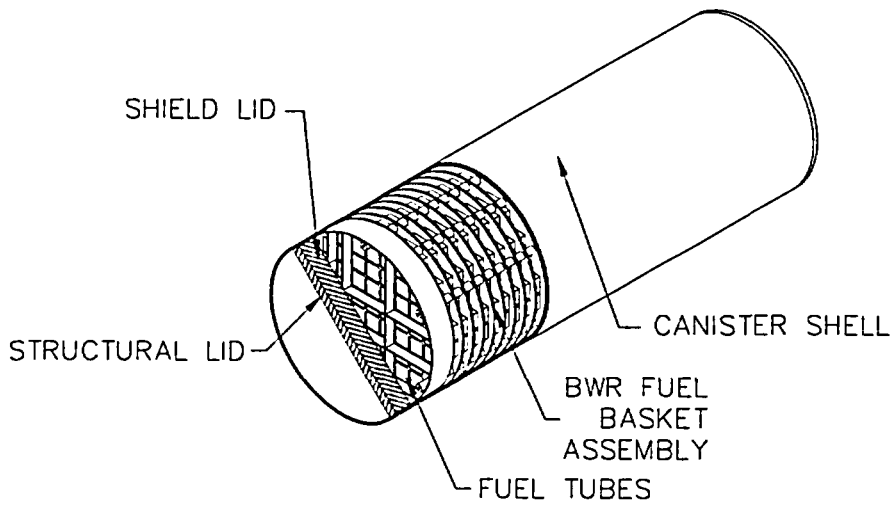

Figure 1.1-3 Transportable Storage Canister Containing BWR Spent Fuel Basket



1.2 General Description of the Universal Storage System

The Universal Storage System provides long-term storage of any of three classes of PWR fuel or two classes of BWR fuel, and subsequent transport using a Universal Transport Cask (Docket 71-9270). During long-term storage, the system provides an inert environment; passive shielding, cooling, and criticality control; and a confinement boundary closed by welding. The structural integrity of the system precludes the release of contents in any of the design basis normal conditions and off-normal or accident events, thereby assuring public health and safety during use of the system.

1.2.1 Universal Storage System Components

The design and operation of the principal components of the Universal Storage System and the associated ancillary equipment are described in the following sections. The weights of the principal components are provided in Section 3.2.

The Universal Storage System consists of three principal components:

- Transportable Storage Canister (including PWR or BWR fuel basket),
- Vertical Concrete Cask, and
- Transfer Cask.

The design characteristics of these components are presented in Table 1.2-1.

Ancillary equipment needed to use the Universal Storage System are:

- Automated or manual welding equipment;
- An air pallet or hydraulic roller skid (used to move the concrete cask on and off the heavy haul trailer and to position the concrete cask on the storage pad);
- Suction pump, vacuum drying, helium backfill and leak detection equipment;
- A heavy haul trailer or transporter (for transport of concrete cask to the storage pad);
- An adapter plate and hardware to position the transfer cask with respect to the storage or transport cask; and
- A lifting yoke for the transfer cask and lifting slings for the canister and canister lids.

In addition to these items, the system requires utility services (electric, helium, air and water), common tools and fittings, and miscellaneous hardware.

1.2.1.1 Transportable Storage Canister

Three classes of Transportable Storage Canisters accommodate the PWR fuel assemblies, and two classes of Transportable Storage Canisters accommodate the BWR fuel assemblies. The canister is designed to be transported in the Universal Transport Cask. Transport conditions establish the design basis load conditions for the canister, except for canister lifting. The transport load conditions produce higher stresses in the canister than would be produced by the storage load conditions. Consequently, the canister design is conservative with respect to storage conditions. The evaluation of the canister for transport conditions is documented in the Safety Analysis Report for the Universal Transport Cask, Docket No. 71-9270.

The Transportable Storage Canister consists of a stainless steel canister that contains the fuel basket structure and contents. The canister is defined as confinement for the spent fuel during storage and is provided with a double welded closure system. The welded closure system prevents the release of contents in any design basis normal, off-normal or accident condition. The basket assembly in the canister provides the structural support and primary heat transfer path for the fuel assemblies while maintaining a subcritical configuration for all normal conditions of storage, off-normal events and hypothetical accident conditions. The PWR and BWR fuel basket assemblies are discussed in Section 1.2.1.2.

The major components of the Transportable Storage Canister are the shell and bottom, basket assembly, shield lid, and structural lid. The canister and the shield and structural lids provide a confinement boundary during storage, shielding, and lifting capability for the basket. The Transportable Storage Canister design parameters for the storage of the five classes of fuel are provided in Table 1.2-2.

The canister consists of a cylindrical, 5/8-inch thick Type 304L stainless steel shell with a 1.75-inch thick Type 304L stainless steel bottom plate and a Type 304 stainless steel shield lid support ring. A basket assembly is placed inside the canister. The shield lid assembly is a 7-inch thick Type 304 stainless steel disk that is positioned on the shield lid support ring above the basket assembly. The shield lid is welded to the canister after the canister is loaded and moved to the workstation for completion of canister closure activities. Two penetrations through the shield lid are provided for draining, vacuum drying, and backfilling the canister with helium. The drain pipe is threaded into the shield lid after the canister is moved to the workstation. The vent penetration in the shield lid is used to aid water removal and for vacuum drying and backfilling the

canister with helium. After the shield lid is welded in place, it is pressure-tested and leak-tested to ensure that the required leak tightness is achieved.

The structural lid is a 3-inch thick Type 304L stainless steel disk positioned on top of the shield lid and welded to the shell after the shield lid is welded in place and the canister is drained, dried, and backfilled with helium. Removable lifting fixtures, installed in the structural lid, are used to lift and lower the loaded canister.

The Transportable Storage Canister is designed to the requirements of the ASME Boiler and Pressure Vessel Code (ASME Code), Section III, Division I, Subsection NB [8]. It is fabricated and assembled in accordance with the requirements of Subsection NB to the maximum extent practicable, consistent with the conditions of use. Exceptions to the ASME Code are noted in Table B3-1 in Appendix B.

A summary of the canister fabrication specifications is presented in Table 1.2-3. As shown in that table, the field installed welds joining the shield and structural lids to the canister shell are not full penetration welds. The shield lid weld is dye penetrant inspected on the root and final cover pass. The structural lid weld is either ultrasonically inspected when completed or it is dye penetrant inspected on the root and final cover passes and on each 3/8-inch intermediate layer. These inspections assure weld integrity in accordance with the requirements of ASME Code Section V, Articles 5 and 6 [9], as appropriate. The weld joining the shield lid to the canister shell is pressure tested and leak tested as described in Section 8.1.1. The structural and shield lid welds are made with the aid of a backing ring (also called a spacer ring) or shims, which cannot be removed when the weld is completed. There are no detrimental effects that result from the presence of the spacer ring or shims, and no structural credit is taken for their presence.

The design of the transportable storage canister and its fabrication controls would allow the canister to be ASME Code stamped in accordance with the ASME Code Section III, if desired.

1.2.1.2 Fuel Baskets

The transportable storage canister contains a fuel basket which positions and supports the stored fuel in normal, off-normal and accident conditions. As described in the following sections, the design of the basket is similar for the PWR and BWR configurations. The fuel basket for each fuel type is designed and fabricated to the requirements of the ASME Code, Section III, Division I, Subsection NG [10]. However, the basket assembly is not Code stamped and no reports

relative to Code stamping are prepared. Consequently, an exception is taken to Article NG-8000, Nameplates, Stamping and Reports.

1.2.1.2.1 PWR Fuel Basket

The PWR fuel basket is contained within the transportable storage canister. It is constructed of stainless steel, but incorporates aluminum disks for enhanced heat transfer. The fuel basket design is a right-circular cylinder configuration with square fuel tubes laterally supported by a series of support disks. The basket design parameters for the storage of the three classes of PWR fuel are provided in Table 1.2-4. The Class 1, 2 or 3 fuel baskets incorporate 30, 32 or 34 support disks, respectively. The disks are retained by a top nut and supported by spacers on tie rods at eight locations. The top nut is torqued at installation to provide a solid load path in compression between the support disks. The support disks are fabricated of SA-693, Type 630, 17-4 PH stainless steel. The disks are spaced axially at 4.92 inches center-to-center and contain square holes for the fuel tubes.

The top and bottom weldments are fabricated from Type 304 stainless steel and are geometrically similar to the support disks. The tie rods and top nuts are fabricated from SA-479, Type 304 stainless steel. The top nut is fabricated from a 3.5-in.-diameter bar, and the spacers are fabricated from a 2.5-in. pipe XXS, Type 304 stainless steel. The fuel tubes are fabricated from A-240, Type 304 stainless steel and support an enclosed neutron absorber sheet on each of the four sides. The neutron absorber provides criticality control in the basket. No credit is taken for the fuel tubes for structural strength of the basket or support of the fuel assemblies.

Each PWR fuel basket has a capacity of 24 PWR fuel assemblies in an aligned configuration in 8.80-inch square fuel tubes. The holes in the top weldment are 8.75-inch square. The holes in the bottom weldment are 8.65-inch square. The basket design traps the fuel tube between the top and bottom weldments, thereby preventing axial movement of the fuel tube. The support disk configuration includes webs between the fuel tubes with variable widths depending on location.

The PWR basket design incorporates Type 6061-T651 aluminum alloy heat transfer disks to enhance heat transfer in the basket. Twenty-nine heat transfer disks are contained in the Class 1 basket. Class 2 and 3 fuel baskets contain 31 and 33 disks, respectively. The heat transfer disks are spaced and supported by the tie rods and spacers, which also support and locate the support disks. The heat transfer disks, located at the center of the axial spacing between the support disks, are sized to eliminate contact with the canister inner shell due to differential thermal expansion.

The Transportable Storage Canister is designed to facilitate filling with water and subsequent draining. Water fills and drains freely between the basket disks through three separate paths. One path is the gaps that exist between the disks and canister shell. The second path is through the gaps between the fuel tubes and disk that surrounds the fuel tubes. The third path is through three 1.3-inch diameter holes in each of the disks that are intended to provide additional paths for water flow between disks. The basket bottom weldment supports the fuel tubes above the canister bottom plate. The fuel tubes are open at the top and bottom ends, allowing the free flow of water from the bottom of the fuel tube. The bottom weldment is positioned by supports 1.0 inch above the canister bottom to facilitate water flow to the drain line. These design features ensure that water flows freely in the basket so that the canister fills and drains evenly.

1.2.1.2.2 BWR Fuel Basket

Like the PWR fuel basket, the BWR basket is contained within the stainless steel Transportable Storage Canister. The BWR fuel basket is also a right-circular cylinder configuration with square fuel tubes laterally supported by a series of support disks (40 disks for the Class 4 fuel basket and 41 disks for the Class 5 fuel basket). The basket design parameters for the storage of the two classes of BWR fuel are provided in Table 1.2-4. The support disks are retained by cylindrical spacers on tie rods at six locations. The top nut is torqued at installation to provide a solid load path in compression between the support disks. The support disks are fabricated of SA-533, Type B, Class 2 carbon steel and are coated with electroless nickel to inhibit corrosion and the formation of combustible gases during fuel loading. The disks are spaced axially at 3.8-inch center-to-center and contain square holes for the fuel tubes.

The top and bottom weldments are fabricated from Type 304 stainless steel, and are geometrically similar to the support disks. The fuel tubes are also fabricated from Type 304 stainless steel. Three types of tubes are designed to contain one BWR fuel assembly: tubes with neutron absorber on two sides, tubes with neutron absorber one side, and tubes with no neutron absorber. No credit is taken for the fuel tubes for structural strength of the basket or support of the fuel assemblies.

Each BWR fuel basket has a capacity of 56 BWR fuel assemblies in an aligned configuration. The fuel tubes in 52 positions have an inside square dimension of 5.90 inches. The inside dimension of the four fuel tubes located in the outside corners of the basket array is 6.05-inches square. The holes in the top weldment are 5.75 inches by 5.75 inches, except for the four enlarged holes, which are 5.90 inches-square. The holes in the bottom weldment are 5.63-inches square. The basket design traps the fuel tube between the top and bottom weldments, thereby

preventing axial movement of the fuel tube. The support disk webs between the fuel tubes are 0.65-inch wide. The BWR fuel basket design also incorporates 17 Type 6061-T651 aluminum alloy heat transfer disks similar in design and function of those in the PWR baskets.

The BWR canister is also designed to facilitate filling with water and subsequent draining. Water fills and drains freely between the basket disks through three separate paths. One path is the gaps that exist between the disks and canister shell. The second path is through the gaps between the fuel tubes and disk that surrounds the fuel tubes. The third path is through three 1.3-inch diameter holes in each of the disks that are intended to provide additional paths for water flow between disks. The basket bottom weldment supports the fuel tubes above the canister bottom plate. The fuel tubes are open at the top and bottom ends, allowing the free flow of water from the bottom of the fuel tube. The bottom weldment is positioned by supports 1.0 inch above the canister bottom to facilitate water flow to the drain line. These design features ensure that water flows freely in the basket so that the canister fills and drains evenly.

1.2.1.3 Vertical Concrete Cask

The Vertical Concrete Cask is the storage overpack for the Transportable Storage Canister. Five concrete casks of different lengths are designed to store five canisters of different lengths containing one of three classes of PWR or of two classes of BWR fuel assemblies. The concrete cask provides structural support, shielding, protection from environmental conditions, and natural convection cooling of the canister during long-term storage. Table 1.2-5 lists the principal physical design parameters of the concrete cask.

The concrete cask is a reinforced concrete (Type II Portland cement) structure with a structural steel inner liner. The concrete wall and steel liner provide the neutron and gamma radiation shielding to reduce the average contact dose rate to less than 50 millirem per hour for design basis PWR or BWR fuel. Inner and outer reinforcing steel (rebar) assemblies are contained within the concrete. The reinforced concrete wall provides the structural strength to protect the canister and its contents in natural phenomena events such as tornado wind loading and wind driven missiles. The concrete cask incorporates reinforced chamfered corners at the edges to facilitate construction. The concrete cask is shown in Figure 1.2-1.

The Vertical Concrete Cask forms an annular air passage to allow the natural circulation of air around the canister to remove the decay heat from the spent fuel. The air inlets and outlets are steel-lined penetrations that take nonplanar paths to the concrete cask cavity to minimize radiation streaming. A baffle assembly directs inlet air upward and around the pedestal that

supports the canister. The weldment structure includes the baffle assembly configuration, as shown in Drawing 790-561. The decay heat is transferred from the fuel assemblies to the tubes in the fuel basket and through the heat transfer disks to the canister wall. Heat flows by radiation and convection from the canister wall to the air circulating through the concrete cask annular air passage and is exhausted through the air outlets. This passive cooling system is designed to maintain the peak cladding temperature of the Zircaloy-clad fuel well below acceptable limits during long-term storage. This design also maintains the bulk concrete temperature below 150°F and localized concrete temperatures below 200°F in normal operating conditions.

The top of the Vertical Concrete Cask is closed by a shield plug and lid. The shield plug is approximately 5 inches thick and incorporates carbon steel plate as gamma radiation shielding, and NS-4-FR or NS-3 as neutron radiation shielding. A carbon steel lid that provides additional gamma radiation shielding is installed above the shield plug. The shield plug and lid reduce skyshine radiation and provide a cover and seal to protect the canister from the environment and postulated tornado missiles. The lid is bolted in place and has tamper indicating seals on two of the installation bolts. An optional supplemental shielding fixture, shown in Drawing 790-613, may be installed in the air inlets to reduce the radiation dose rate at the base of the cask.

Fabrication of the concrete cask involves no unique or unusual forming, concrete placement, or reinforcement requirements. The concrete portion of the concrete cask is constructed by placing concrete between a reusable, exterior form and the inner metal liner. Reinforcing bars are used near the inner and outer concrete surfaces, to provide structural integrity. The inner liner and base of the concrete cask are shop fabricated. The principal fabrication specifications for the concrete cask are shown in Table 1.2-6.

1.2.1.4 Transfer Cask

The transfer cask is a heavy lifting device, which is designed, fabricated, and load-tested to meet the requirements of NUREG-0612 [11] and ANSIN14.6 [12]. The transfer cask can be provided in either a Standard or Advanced configuration. Canister handling, fuel loading and canister closing are operationally identical for either transfer cask configuration.

The transfer cask provides biological shielding when it contains a loaded canister and is used for the vertical transfer of the canister between work stations and the concrete cask, or transport cask. Five transfer casks of either configuration, having different lengths, are designed to handle the five canisters of different lengths containing one of three classes of PWR fuel assemblies or two classes of BWR fuel assemblies. In addition, a Transfer Cask Extension may be used to extend the

operational height, when using the standard transfer cask. This height extension allows a transfer cask designed for a specific canister class to be used with the next longer canister.

The transfer cask design incorporates a top retaining ring, which is bolted in place to prevent a loaded canister from being inadvertently lifted through the top of the transfer cask. The transfer cask has retractable bottom shield doors. During loading operations, the doors are closed and secured by door lock bolts/lock pins, so they cannot inadvertently open. During unloading, the doors are retracted using hydraulic cylinders to allow the canister to be lowered into a concrete cask for storage or into a transport cask. A typical transfer cask is shown in Figure 1.2-2. The principal design parameters of the transfer casks are shown in Table 1.2-7.

To minimize the potential for contamination of a canister or the inside of the transfer cask during loading operations in the spent fuel pool, clean water is circulated in the annular gap between the transfer cask interior surface and the canister exterior surface. Clean water is processed or filtered pool water, or any water external to the spent fuel pool that is compatible. The transfer cask has eight supply and two discharge lines passing through its wall. Normally, two of the lines are connected to allow clean water under pressure to flow into and through the annular gap to minimize potential for the intrusion of pool water when the canister is being loaded. Lines not used for clean water supply may be capped. The eight supply lines can also be used for the introduction of forced air at the bottom of the transfer cask to achieve cooling of the canister contents. This allows the canister to remain in the transfer cask for an extended period, if necessary, during canister closing operations.

Standard and Advanced Transfer Casks

The Standard and Advanced transfer casks are designed for lifting and handling in the vertical orientation only. The Standard transfer cask may be used to lift canisters weighing up to 88,000 pounds. The Advanced transfer cask is similar to the Standard transfer cask, except that the Advanced transfer cask incorporates a trunnion support plate that allows the Advanced transfer cask to lift canisters weighing up to 98,000 pounds. The Standard and Advanced transfer casks have four lifting trunnions, which allow for redundant load path lifting. Both transfer casks incorporate a multiwall (steel/lead/NS-4-FR/steel) design, and both designs have a maximum empty weight of approximately 121,500 pounds. The Standard and Advanced transfer cask designs are shown in Drawing 790-560.

1.2.1.5 Auxiliary Equipment

This section presents a brief description of the principal auxiliary equipment needed to operate the Universal Storage System in accordance with its design.

1.2.1.5.1 Transfer Adapter

The transfer adapter is a carbon steel table that is positioned on the top of the Vertical Concrete Cask or the Universal Transport Cask and mates the transfer cask to either of those casks. It has a large center hole that allows the Transportable Storage Canister to be raised or lowered through the plate into or out of the transfer cask. Rails are incorporated in the transfer adapter to guide and support the bottom shield doors of the transfer cask when they are in the open position. The transfer adapter also supports the hydraulic system and the actuators that open and close the transfer cask bottom doors.

1.2.1.5.2 Air Pad Rig Set

The air pad rig set (air pad set) is a commercially available device, sometimes referred to as an air pallet. When inflated, the air pad rig set lifts the concrete cask by using high volume air flow. The air pads employ a continuous, regulated air flow and a control system that equalizes lifting heights of the four air pads by regulating compressed air flow to each of the air pads. The compressed air supply creates an air film between the inflated air cushion and the supporting surface. The thin film of air allows the concrete cask to be lifted and moved. Once lifted, the cask can be moved by a suitable towing vehicle, such as a commercial tug or forklift.

1.2.1.5.3 Automatic Welding System

The automatic welding system consists of commercially available components with a customized weld head. The components include a welding machine, a remote pendant, a carriage, a drive motor and welding wire motor, and the weld head. The system is designed to make at least one weld pass automatically around the canister after its weld tip is manually positioned at the proper location. As a result, radiation exposure during canister closure is much less than would be incurred from manual welding.

1.2.1.5.4 Draining and Drying System

The draining and drying system consists of a suction pump and a vacuum pump. The suction pump is used to remove free water from the canister cavity. The vacuum pump is a two-stage unit for drying the interior of the canister. The first stage is a large capacity or “roughing” pump intended to remove free water not removed by the suction pump. The second stage is a vacuum pump used to evacuate the canister interior of the small amounts of remaining moisture and establish the vacuum condition.

1.2.1.5.5 Lifting Jacks

Hydraulic jacks are installed at jacking pads in the air inlets at the bottom of the concrete cask to lift the cask so that the air pad set can be installed or removed. Four hydraulic jacks are provided, along with a control panel, an electric hydraulic oil pump, an oil reservoir tank and all hydraulic lines and fittings. The jacks are used to lift the cask approximately three inches. This permits installation of the air pad rig set under the concrete cask.

1.2.1.5.6 Heavy-Haul Trailer

The heavy-haul trailer is used to move the Vertical Concrete Cask. A special trailer is designed for transport of the empty or loaded concrete cask. The design incorporates a jacking system that facilitates raising the concrete cask to allow installation of the air pad set used to move the cask onto the storage pad. The trailer incorporates both reinforcing to increase the trailer load-bearing area and design features that reduce its turning radius. However, any commercial double-drop-frame trailer having a deck height approximately matching that of the storage pad could be used.

1.2.1.5.7 Helium Leak Test Equipment

A helium leak detector and leak test fixture are required to verify the integrity of the welds of the canister shield lid. The helium leak detector is the mass spectrometer type.

1.2.1.5.8 Rigging and Slings

Load rated rigging attachments and slings are provided for major components. The rigging attachments are swivel hoist rings that allow attachment of the slings to the hook. All slings are commercially purchased to have adequate safety margin to meet the requirements of ANSI N14.6 and NUREG-0612. The slings include a concrete cask lid sling, concrete cask shield plug

sling, canister shield lid sling, loaded canister transfer sling (also used to handle the structural lid), and a canister retaining ring sling. The appropriate rings or eye bolts are provided to accommodate each sling and component.

The transfer cask lifting yoke is specially designed and fabricated for lifting the transfer cask. It is designed to meet the requirements of ANSI N14.6 and NUREG-0612. It is designed as a special lifting device for critical loads. The transfer cask lifting yoke is initially load tested to 300 percent of the maximum service load.

1.2.1.5.9 Transfer Cask Extension

A transfer cask extension may be used to extend the operational height of a transfer cask by approximately 10 inches. This height extension allows a transfer cask designed for a specific canister class to be used with the next longer canister. The extension is stainless steel.

1.2.1.5.10 Temperature Instrumentation

The Vertical Concrete Cask has four air outlets near the top of the cask and four air inlets at the bottom. Each outlet is equipped with a permanent remote temperature detector mounted in the outlet air plenum. The detector is used to measure the outlet air temperature, which can be read at a display device located on the outside surface of the concrete cask or at a remote location. The detectors are installed on all of the concrete casks at the Independent Spent Fuel Storage Installation (ISFSI) facility.

1.2.1.6 Universal Transport Cask

The Universal Transport Cask is designed to transport the Transportable Storage Canister. The canister, which may contain PWR or BWR spent fuel, is positioned in the Universal Transport Cask cavity by axial spacer(s) at the bottom of the cavity. A Class 1, 2 or 5 canister is located by one spacer. A Class 4 canister is located by four spacers. A Class 3 canister has no spacers. The spacer(s) are required because the Universal Transport Cask cavity length is 192.5 inches, while the lengths of the canisters for different classes of fuel vary from 175.3 inches to 192.0 inches.

The transport configuration of the Universal Transport Cask is shown in Figure 1.2-3. The Universal Transport Cask is assigned 10 CFR 71 [13] Docket No. 71-9270 [3].

1.2.2 Operational Features

In storage, the only active system is for temperature monitoring of the outlet air. This temperature is recorded daily as a check of the thermal performance of the concrete casks. This system does not penetrate the confinement boundary and is not essential to the safe operation of the Universal Storage System.

The principal activities associated with the use of the Universal Storage System are closing the canister and loading the canister in the concrete cask. The transfer cask is designed to meet the requirements of these operations. The transfer cask holds the canister during loading with fuel; provides biological shielding during closing of the canister; and provides the means by which the loaded canister is moved to, and installed in, the concrete cask.

The canister consists of five principal components: the canister shell (side wall and bottom); the shield lid; the vent port; the drain port (together with the vent and drain port covers); and the structural lid. A drain tube extends from the shield lid drain port to the bottom of the canister. The location of the drain and vent ports is shown in Figure 8.1.1-1. The vent and drain ports allow the draining, vacuum drying, and backfilling with helium necessary to provide a dry, inert atmosphere for the contents. The vent and drain port covers, the shield lid, the canister shell, and the joining welds form the primary confinement boundary. A secondary confinement boundary is formed over the shield lid by the structural lid and the weld that joins it to the canister shell. The primary and secondary boundaries are shown in Figures 7.1-1 and 7.1-2.

The structural lid contains the drilled and tapped holes for attachment of the swivel hoist rings used to lift the loaded canister. The drilled and tapped holes are filled with bolts or plugs to avoid collecting debris, and to preclude the possibility of radiation streaming from the holes, when the hoist rings are not installed.

The step-by-step procedures for the operation of the Universal Storage System are presented in Chapter 8.0. The following is a list of the principal activities. This list assumes that the empty canister is installed in the transfer cask for spent fuel pool loading (see Figure 1.2-4).

- Lift the transfer cask over the pool and start the flow of clean or filtered pool water to the transfer cask annulus and canister. After the annulus and canister fill, lower the cask to the bottom of the pool.
- Load the selected spent fuel assemblies into the canister and set the shield lid.

- Raise the transfer cask from the pool. Decontaminate the transfer cask exterior as it clears the pool surface. Drain the annulus. Place the transfer cask in the decontamination area.
Note: As an alternative, some sites may choose to perform welding operations for closure of the canister in a cask loading pit with water around the canister (below the trunnions) and in the annulus. This alternative provides additional shielding during the closure operation.
- Weld the shield lid to the canister shell. Inspect and pressure test the weld. Drain the pool water from the canister. Attach the vacuum system to the drain line, and operate the system to achieve a vacuum.
- Hold the vacuum and backfill with helium to 1 atmosphere. Restart the vacuum system and remove the helium. After achieving vacuum, backfill and pressurize the canister with helium.
- Helium leak check the shield lid welds. Vent the helium pressure to 1 atmosphere (absolute). Install the vent and drain port covers and weld them to the shield lid. Inspect the port cover welds.
- Install the structural lid and weld it to the canister shell. Inspect the structural lid weld. Install the hoist rings, and attach the canister lifting sling. Install the transfer adapter on the concrete cask.
- Lift the transfer cask to the top of the concrete cask and set it on the transfer adapter. (See Figure 1.2-5). Ensure that the bottom door hydraulic actuators are engaged.
- Attach the canister lifting slings to the crane hook and lift the canister.
- Open the bottom doors of the transfer cask.
- Lower the canister into the concrete cask (see Figure 1.2-6). Remove the canister lifting slings.
- Remove the transfer cask and transfer adapter.
- Install the shield plug and lid on the concrete cask.
- Move the loaded concrete cask to the storage pad.
- Using the air pad rig set and a towing vehicle, move the concrete cask to its designated location on the storage pad.

The removal operations are essentially the reverse of these steps, except that weld removal and cool down of the contents is required.

The auxiliary equipment needed to operate the Universal Storage System is described in Section 1.2.1.5. Other items required are miscellaneous hardware, connection hose and fittings, and hand tools typically found at a reactor site.

Figure 1.2-1 Vertical Concrete Cask

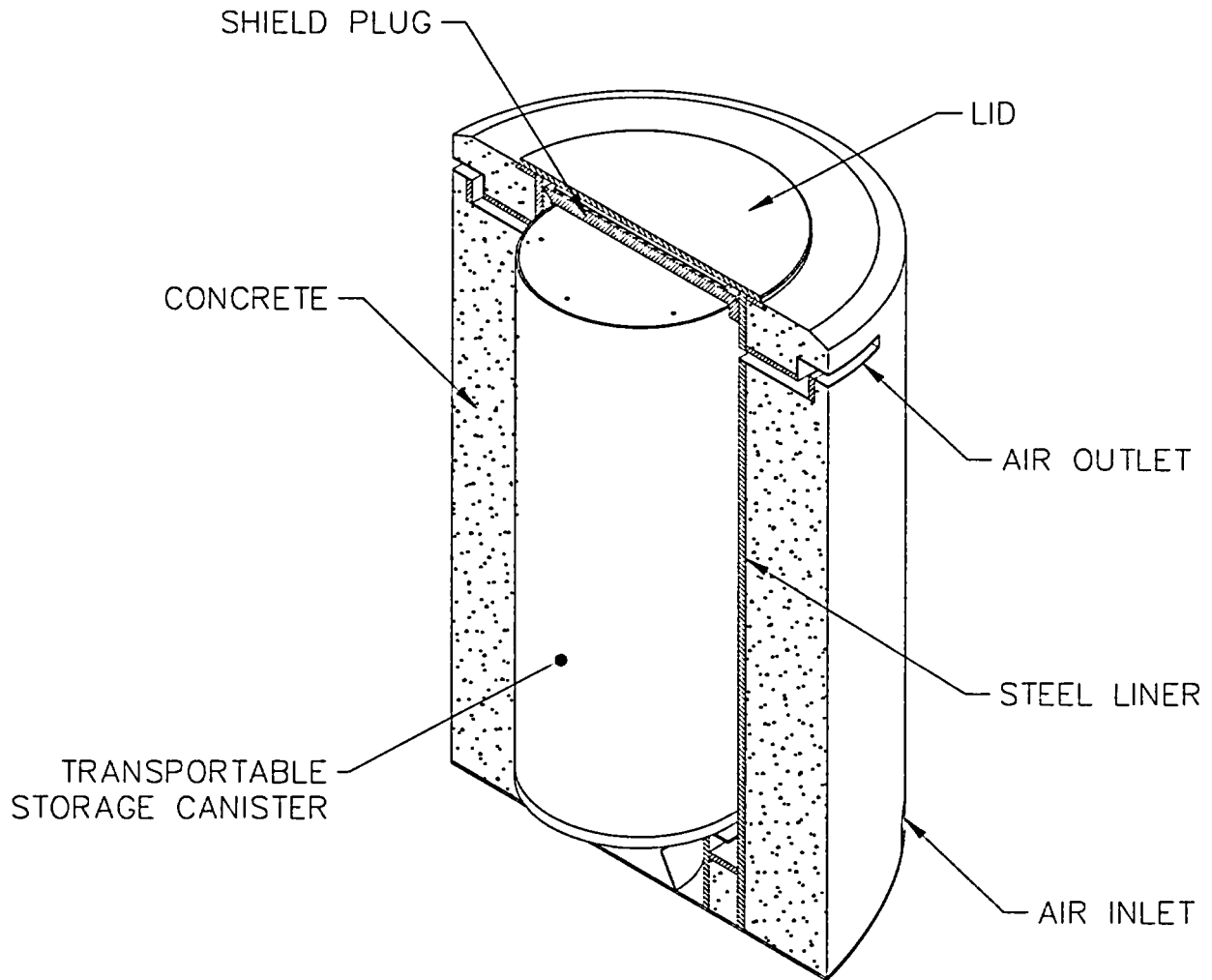
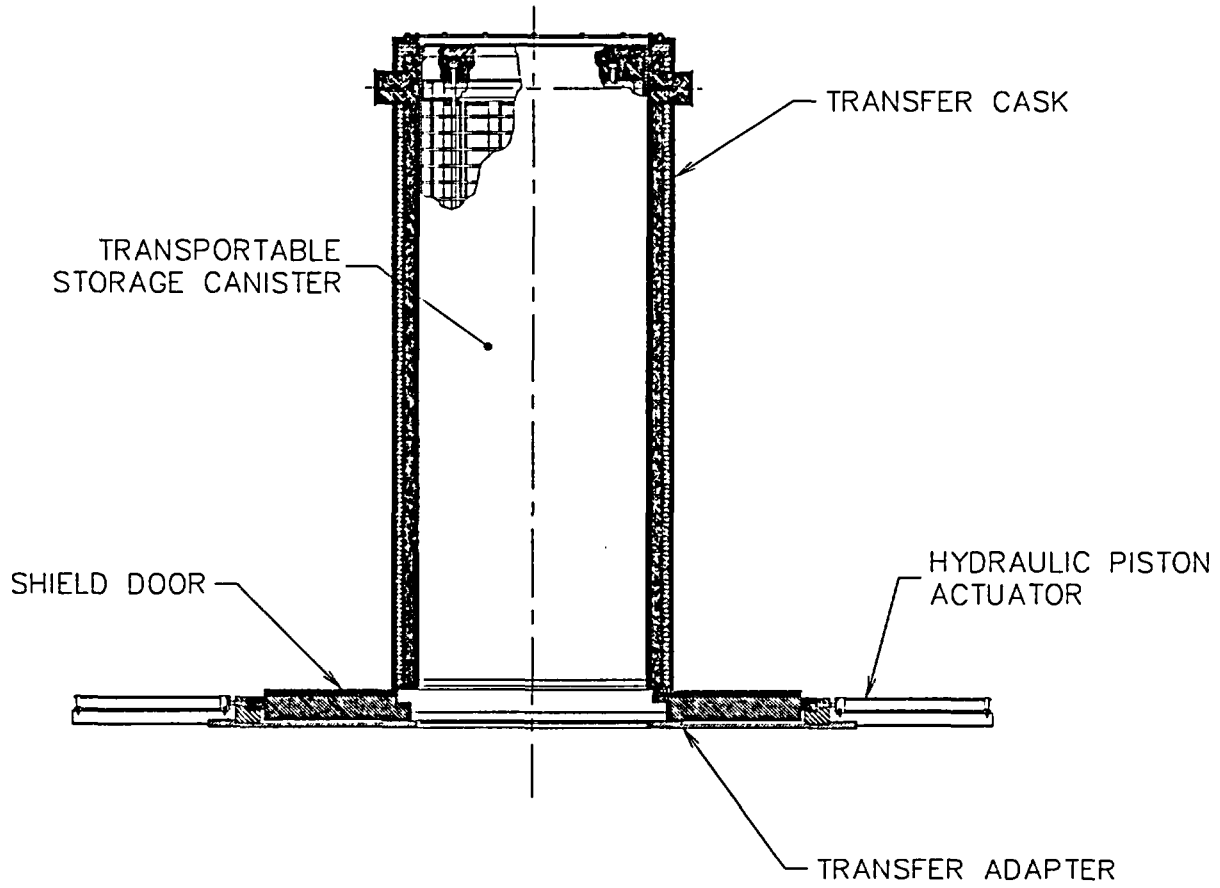

Figure 1.2-2 Transfer Cask



Typical Transfer Cask with Transfer Adapter

Figure 1.2-3 Transport Configuration of the Universal Transport Cask

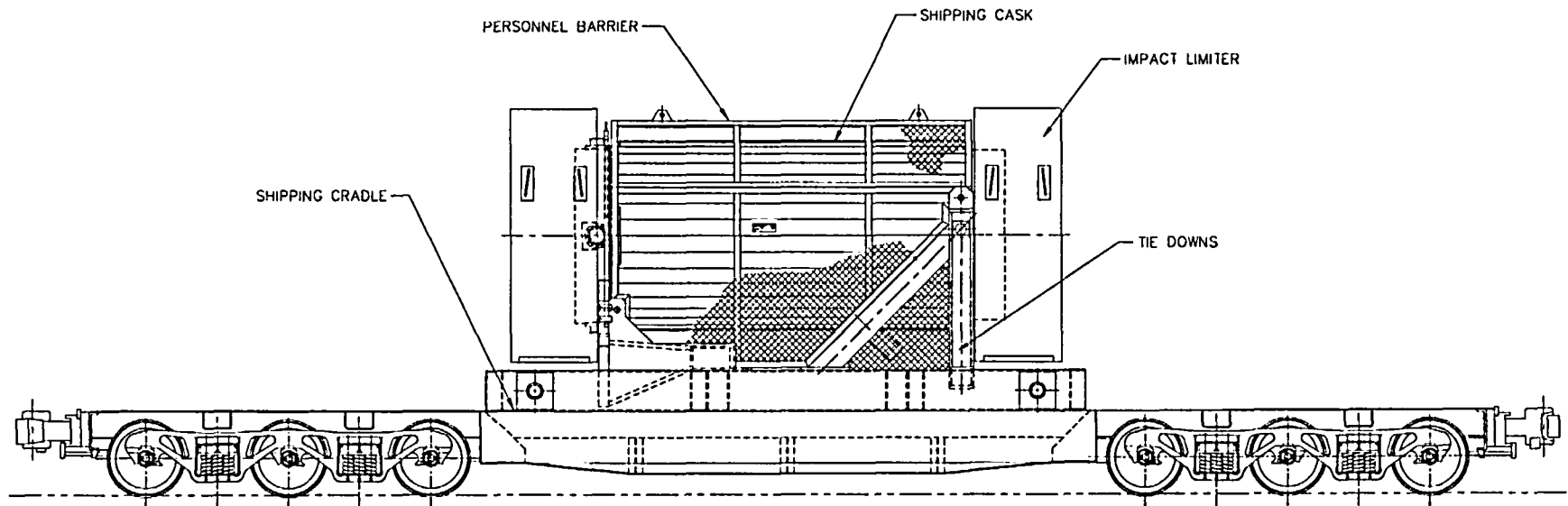

Figure 1.2-4 Transfer Cask and Canister Arrangement

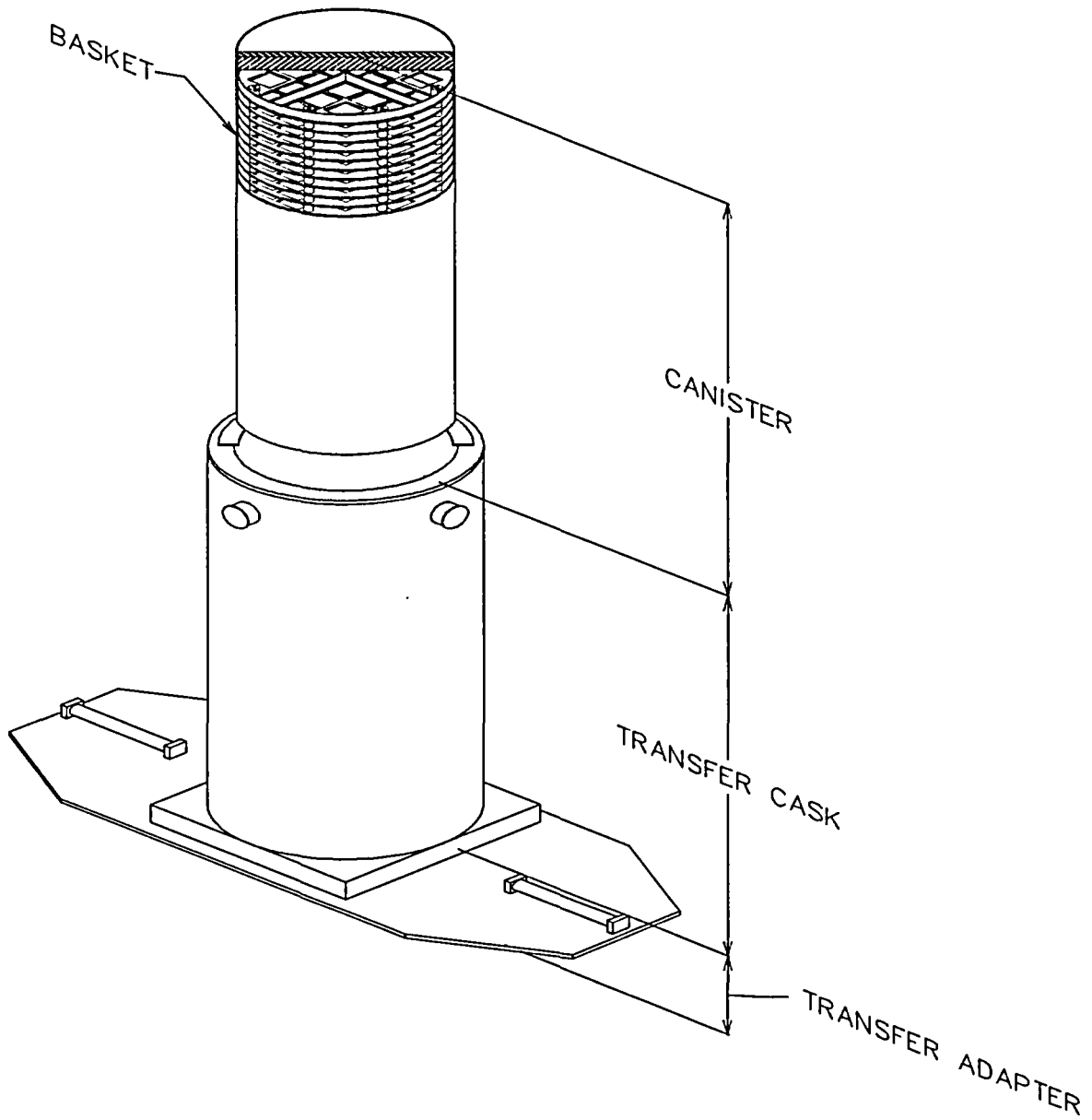

Figure 1.2-5 Vertical Concrete Cask and Transfer Cask Arrangement

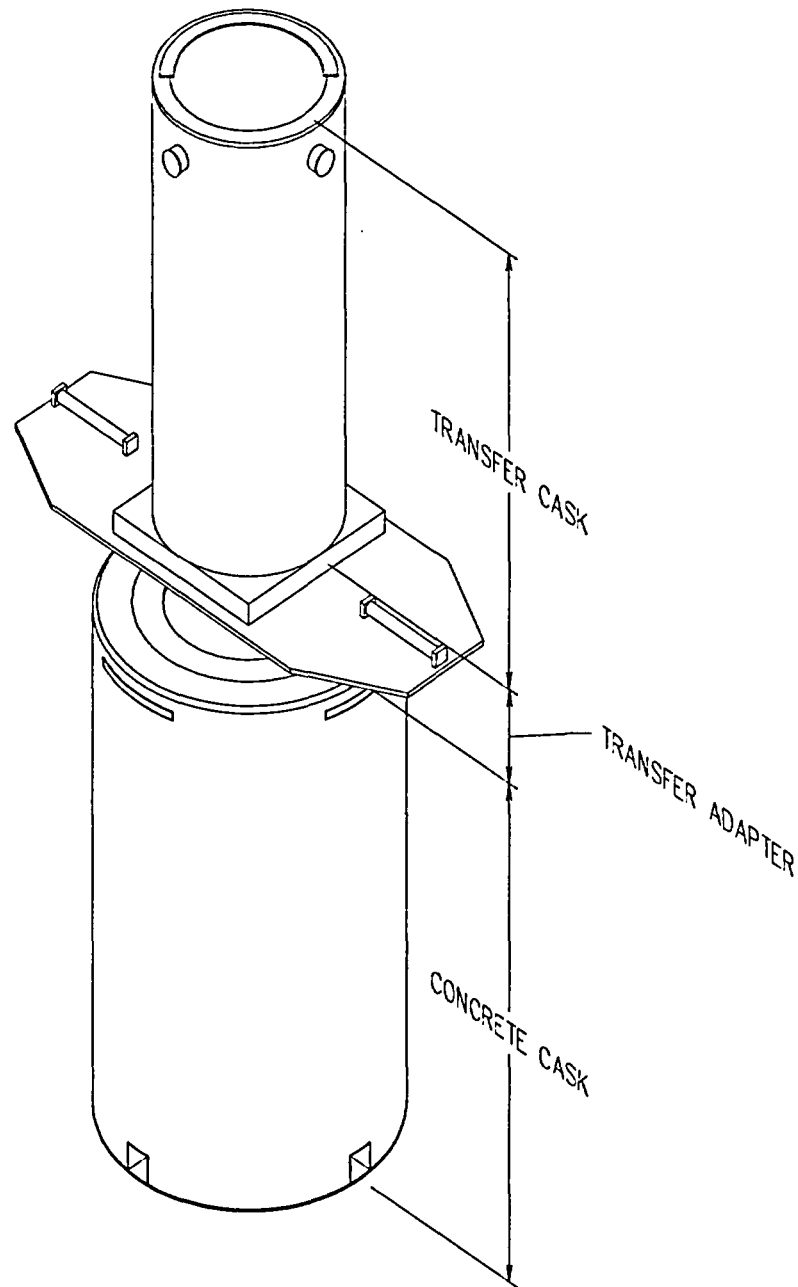

Figure 1.2-6 Major Component Configuration for Loading the Vertical Concrete Cask

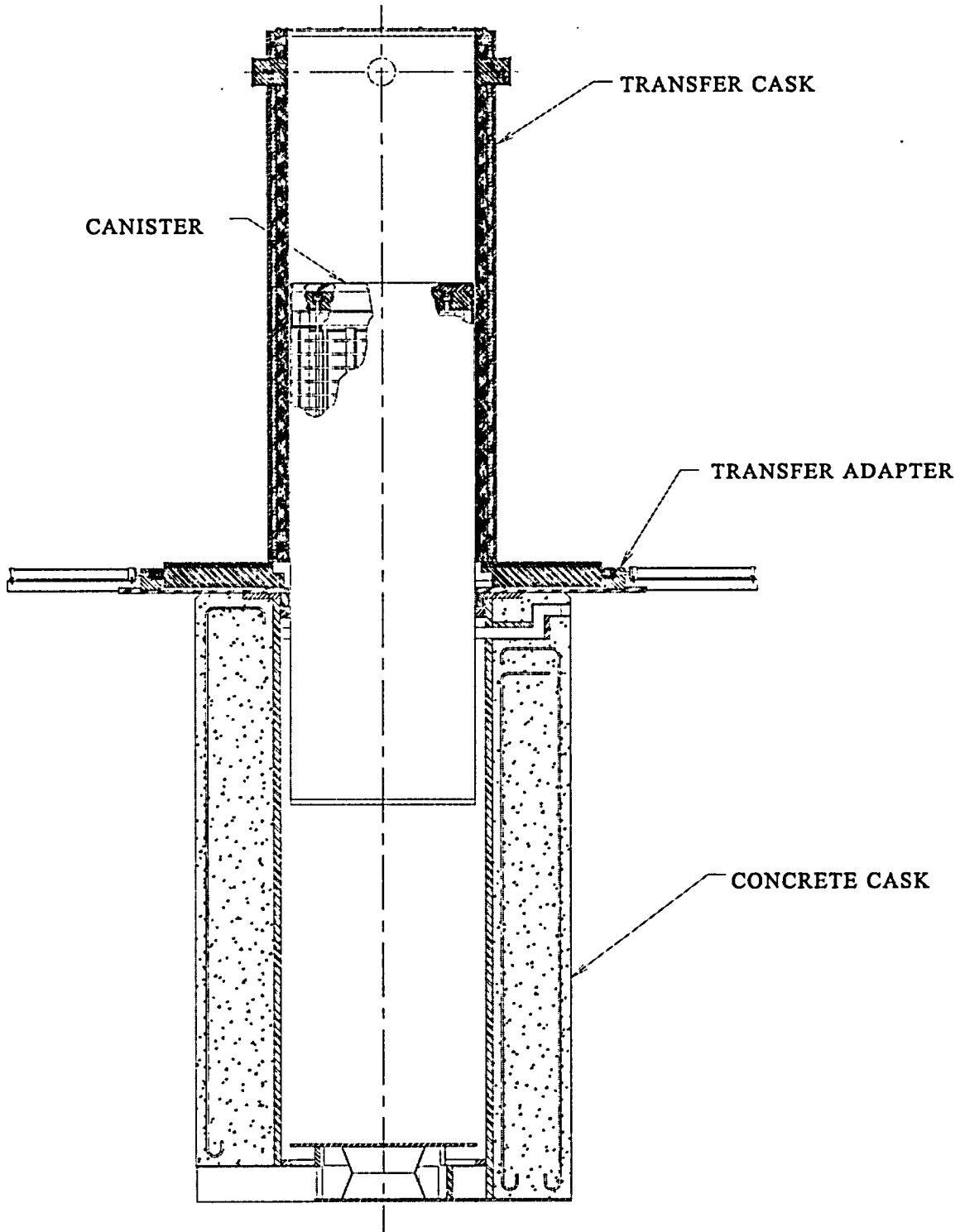

Table 1.2-1 Design Characteristics of the UMS[®] Universal Storage System

Design Characteristic	Value (in.)	Material
Transportable Storage Canister		
Shell thickness	0.625	Type 304L Stainless Steel
Shell bottom thickness	1.75	Type 304L Stainless Steel
Shield lid thickness	7	Type 304 Stainless Steel
Structural lid thickness	3	Type 304L Stainless Steel
Canister Fuel Basket		
Top weldment PWR thickness	1.25	Type 304 Stainless Steel
Bottom weldment PWR thickness	1.0	Type 304 Stainless Steel
Top and bottom weldment BWR thickness	1.0	Type 304 Stainless Steel
Support disks thickness		
- PWR	0.5	Type 17-4 PH Stainless Steel
- BWR	0.625	SA-533, Type B Class 2 Carbon Steel
Heat transfer disk thickness	0.5	Type 6061-T651 Aluminum Alloy
Fuel tube dimensions		
- PWR (inside)	8.8 × 8.8	Type 304 Stainless Steel Enclosing neutron absorber
- BWR Standard (inside)	5.9 × 5.9	Type 304 Stainless Steel Enclosing neutron absorber
- BWR Over-Sized Fuel (inside)	6.05 × 6.05	Type 304 Stainless Steel Enclosing neutron absorber
Spacer(s) diameter	2.875	Type 304 Stainless Steel
Tie rod diameter		
- PWR	1-5/8	Type 304 Stainless Steel
- BWR	1-5/8	Type 304 Stainless Steel

Table 1.2-1 Design Characteristics of the UMS® Universal Storage System (Continued)

Design Characteristic	Value (in.)	Material
Standard and Advanced Transfer Cask Outer Shell Inner Shell Retaining Ring Trunnions Bottom Plate Top Plate Shield Doors Door Rails Gamma Shield Neutron Shield	1.25 × 85.3 dia. 0.75 × 67.8 dia. 0.75 × 77.1 dia. 10.0 dia. 1.0 thick plate 2.0 thick plate 9.0 thick 9.4 × 6.5 4.0 thick 2.75 thick	ASTM A588 Low Alloy Steel ASTM A588 Low Alloy Steel ASTM A588 Low Alloy Steel A350 LF2 Low Alloy Steel ASTM A588 Low Alloy Steel ASTM A588 Low Alloy Steel A350 LF2 Low Alloy Steel and NS-4-FR A350 LF2 Low Alloy Steel ASTM B29, Chemical Copper Grade Lead NS-4-FR, Solid Synthetic Polymer
Transfer Adapter Base Plate Locating Ring	2.0 thick plate 2.75 wide × 73.75	ASTM A36 Carbon Steel ASTM A36 Carbon Steel

Table 1.2-1 Design Characteristics of the UMS[®] Universal Storage System (Continued)

Design Characteristic	Value (in.)	Material
Vertical Concrete Cask		
Weldment Structure		
Shell	2.5 thick × 79.50 dia	ASTM A36 Carbon Steel
Top Flange	2.0 thick × 101.40 dia.	ASTM A36 Carbon Steel
Support Ring	2.5 thick × 74.50 dia.	ASTM A36 Carbon Steel
Base Plate	2.0 thick × 67.50 dia.	ASTM A36 Carbon Steel
Concrete Cask		
Concrete Shell	28.3 thick × 136 dia.	Type II Portland Cement
Shield Plug (NS-4-FR)	5.13 × 74.0 dia.	ASTM A36 Carbon Steel and NS-4-FR
Shield Plug (NS-3)	5.63 × 74.0 dia.	ASTM A36 Carbon Steel and NS-3
Cask Lid	1.50 thick × 85.6 dia.	ASTM A36 Carbon Steel
Rebar	Various Lengths	ASTM A615, GR 60, ASTM A615, GR75, and A-706 Carbon Steel

Table 1.2-2 Major Physical Design Parameters of the Transportable Storage Canister

Canister Parameter	Value
Canister Shell	
Outside Diameter (in.)	67.1
Thickness (in.)	0.625
Overall Length (in.)	
Class 1 (PWR)	175.1
Class 2 (PWR)	184.2
Class 3 (PWR)	191.8
Class 4 (BWR)	185.6
Class 5 (BWR)	190.4
Capacity (No. of fuel assemblies)	
Classes 1 – 3 (PWR)	24
Classes 4 – 5 (BWR)	56
Maximum Heat Load (kW)	
PWR	23.0
BWR	23.0
Maximum Long-Term Fuel Cladding Temperature – 5-year cooled fuel (°F [°C])	
Classes 1 – 3 (PWR)	752 (400)
Classes 4 – 5 (BWR)	752 (400)
Internal Atmosphere	Helium

Table 1.2-3 Transportable Storage Canister Fabrication Specification Summary

Materials

- All material shall be in accordance with the referenced drawings and meet the applicable ASME code sections.

Welding

- All welds shall be in accordance with the referenced drawings.
- All filler metals shall be appropriate ASME materials.
- All welders and welding operators shall be qualified in accordance with ASME Section IX [14].
- All welding procedures shall be written and qualified in accordance with ASME Section IX.
- All welds specified to be visually examined shall be examined as specified in ASME Section V, Article 9 with acceptance per ASME Code Section VIII [15], UW-35 and UW-36.
- All welds specified to be dye penetrant examined shall be examined in accordance with the requirements of ASME Section V, Article 6, with acceptance in accordance with ASME Section III, NB-5350.
- All personnel performing examinations shall be qualified in accordance with the NAC International Quality Assurance program and SNT-TC-1A [16].
- All welds specified to be radiographed shall be examined in accordance with the requirements of ASME Code Section V, Article 2, with acceptance per ASME Code Section III, NB 5320.
- All welds specified to be ultrasonically examined shall be examined per ASME Code Section V, Article 5, with acceptance per ASME Code Section III, NB-5330.

Fabrication

- All cutting, welding, and forming shall be in accordance with ASME Code Section III, NB-4000 unless otherwise specified. Code stamping is not required.
- All surfaces shall be cleaned to a surface cleanliness classification C or better as defined in ANSI N45.2.1 [17], Section 2.
- All fabrication tolerances shall meet the requirements of the referenced drawings after fabrication.
- Fit-up testing of a “dummy” fuel assembly into each fuel tube and insertion of the completed basket into the canister shell is required. Verification of the basket overall length and diameter is required.

Packaging

- Packaging and shipping shall be in accordance with ANSI N45.2.2 [18].

Quality Assurance

- The canister shall be fabricated under a quality assurance program that meets 10 CFR 72 Subpart G and 10 CFR 71 Subpart H.
- The supplier’s quality assurance program must be accepted by the licensee prior to initiation of work.
- A Certificate of Conformance shall be issued by the fabricator stating that the canister meets the specifications and drawings.

Table 1.2-4 Major Physical Design Parameters of the Fuel Basket

Basket Parameter	Value
Basket Assembly Length, in.	
Class 1 (PWR)	162.6
Class 2 (PWR)	171.7
Class 3 (PWR)	179.3
Class 4 (BWR)	173.1
Class 5 (BWR)	177.9
Basket Assembly Diameter, in.	65.5
Number of Support Disks	
Class 1 (PWR)	30
Class 2 (PWR)	32
Class 3 (PWR)	34
Class 4 (BWR)	40
Class 5 (BWR)	41
Number of Heat Transfer Disks	
Class 1 (PWR)	29
Class 2 (PWR)	31
Class 3 (PWR)	33
Class 4 (BWR)	17
Class 5 (BWR)	17
Number of Fuel Tubes	
Classes 1 – 3 (PWR)	24 (with neutron absorber on all four sides)
Classes 4 – 5 (BWR)	56 (42 with neutron absorber on two sides; 11 with neutron absorber on one side; and 3 with no neutron absorber)
Number of Tie Rods	
Classes 1 – 3 (PWR)	8
Classes 4 – 5 (BWR)	6

Table 1.2-5 Major Physical Design Parameters of the Vertical Concrete Cask

Parameter	Value
Height (in.)	
Class 1 (PWR)	209.2
Class 2 (PWR)	218.3
Class 3 (PWR)	225.9
Class 4 (BWR)	219.7
Class 5 (BWR)	224.5
Outside diameter (in.)	136.0
Nominal weight (lbs), Without Canister (140 pcf concrete)	223,500
Class 1 (PWR)	232,300
Class 2 (PWR)	239,700
Class 3 (PWR)	233,700
Class 4 (BWR)	238,400
Class 5 (BWR)	
Shielding (side wall)	
Concrete thickness (in.)	28.2
Steel liner thickness (in.)	2.5
Radiation dose rate (mrem/hr):	
Side surface	< 50 (average)
Top surface	<50 (average)
Air inlet/outlet	< 100 (average)
Air flow at design heat load (lb-m)/sec	1
Material of construction	
Concrete	Type II Portland Cement
Reinforcing steel	A615 Grade 60
Steel liner	A36 Carbon Steel
Service life (years)	50
Maximum concrete temperatures for normal operation (°F)	150 (bulk) 200 (local)

Table 1.2-6 Vertical Concrete Cask Fabrication Specification Summary

Materials

- Concrete mix shall be in accordance with the requirements of ACI 318 and ASTM C94 [19].
- Type II Portland Cement, ASTM C150 [20].
- Fine aggregate ASTM C33 [21] or C637 [22].
- Coarse aggregate ASTM C33.
- If concrete temperatures of general or local areas exceed 200°F but would not exceed 300°F, aggregates are selected which are acceptable for concrete in this temperature range. The following criteria for fine and coarse aggregates are acceptable:
 - Satisfy ASTM C33 requirements and other requirements referenced in ACI 349 for aggregates, and
 - Have demonstrated a coefficient of thermal expansion (tangent in temperature range of 70°F to 100°F) no greater than 6×10^{-6} in./in./°F, or be one of the following minerals: limestone, dolomite, marble, basalt, granite, gabbro, or rhyolite.
- Admixtures
 - Water Reducing and Superplasticizing ASTM C494 [23].
 - Pozzolanic Admixture (Loss on Ignition 6% or less) ASTM C618 [24].
- Compressive Strength 4000 psi at 28 days.
- Specified Air Entrainment per ACI 318.
- All steel components shall be of material as specified in the referenced drawings.

Welding

- Visual inspection of all welds shall be performed to the requirements of AWS D1.1, Section 8.6.1 [25].

Construction

- A minimum of two concrete samples for each concrete cask shall be taken in accordance with ASTM C172 [26] and ASTM C31 [27] for the purpose of obtaining concrete slump, density, air entrainment, and 28-day compressive strength values. The two samples shall not be taken from the same batch or truckload.
- Test specimens shall be tested in accordance with ASTM C39 [28].
- Formwork shall be in accordance with ACI 318.
- All sidewall formwork shall remain in place in accordance with ACI 318.
- Grade, type, and details of all reinforcing steel shall be in accordance with the referenced drawings.
- Embedded items shall conform to ACI 318 and the referenced drawings.
- The placement of concrete shall be in accordance with ACI 318.
- Surface finish shall be in accordance with ACI 318.

Quality Assurance

The concrete cask shall be constructed under a quality assurance program that meets 10 CFR 72 Subpart G. The quality assurance program must be accepted by NAC International and the licensee prior to initiation of the work.

Table 1.2-7 Major Physical Design Parameters of the Transfer Casks

Parameter	Transfer Cask Configuration	
	Standard	Advanced
Inside Diameter (in.)	67.8	67.8
Outside Diameter (in.)	85.3	85.3
Cavity Height (nominal) (in.)		
Class 1	177.3	177.3
Class 2	186.4	186.4
Class 3	194.0	194.0
Class 4	187.8	187.8
Class 5	192.6	192.6
Empty Weight (nominal) (lbs)		
Class 1	112,300	112,300
Class 2	117,300	117,300
Class 3	121,500	121,500
Class 4	118,100	118,100
Class 5	120,700	120,700
Allowable Canister Weight	≤ 88,000	≤ 98,000

1.3 Universal Storage System Contents

The Universal Storage System is designed to store up to 24 PWR fuel assemblies or up to 56 BWR fuel assemblies. The design basis fuel contents are subject to the limits presented in Section 1.3.1. Site specific contents are described in Section 1.3.2. The site specific contents are either shown to be bounded by the evaluation of the design basis fuel, or are separately evaluated to establish limits which are maintained by administrative controls.

1.3.1 Design Basis Spent Fuel

The Universal Storage System is evaluated based on a set of fuel assembly parameters that establish bounding conditions for the system. The bounding fuel parameters are provided in Table 2.1.1-1 for PWR fuel and in Table 2.1.2-1 for BWR fuel. Fuel assembly designs having parameters bounded by those in Tables 2.1.1-1 and 2.1.2-1 are acceptable for loading. Four different assembly array sizes: 14 × 14, 15 × 15, 16 × 16 and 17 × 17, produced by several different fuel vendors, were evaluated in the development of the PWR design basis spent fuel description. Three different arrays: 7 × 7, 8 × 8 and 9 × 9, produced by several different fuel vendors were evaluated in the development of the BWR design basis spent fuel description.

The Universal Storage System fuel limits are:

1. The characteristics of the PWR and BWR fuel to be stored shall be in accordance with Tables 2.1.1-1 and 2.1.2-1, respectively.
2. The total decay heat of the PWR fuel shall not exceed 23.0 kW.
3. The total decay heat of the BWR fuel shall not exceed 23.0 kW.
4. The maximum UO₂ weight (MTU) shall not exceed 11.53 MTU for PWR and 11.08 MTU for BWR fuel assemblies.
5. The maximum initial enrichment shall not exceed 5.0 wt % ²³⁵U for PWR and 4.8 wt % ²³⁵U for BWR fuel assemblies.

6. The maximum initial enrichment of the PWR fuel is based on a pool/canister water boron content of at least 1,000 parts per million for some fuel parameter combinations. The maximum initial enrichment of the BWR fuel is defined as the maximum initial peak planar-average enrichment. The initial peak planar-average enrichment is the maximum initial peak planar-average enrichment at any height along the axis of the fuel assembly. The initial peak planar-average may be higher than the bundle average enrichment value that appears in fuel design or plant documents. Unenriched fuel assemblies are not evaluated and are not included as a proposed content.
7. The maximum PWR fuel assembly burnup (MWD/MTU) and minimum cooling time (years) shall be as defined by Table 2.1.1-2.
8. The maximum BWR fuel assembly burnup (MWD/MTU) and minimum cooling time (years) shall be as defined by Table 2.1.2-2.
9. Radiation levels shall not exceed the requirements of 10 CFR 72.104 and 10 CFR 72.106.
10. An inert atmosphere shall be maintained within the canister where spent fuel is stored.
11. Stainless steel spacers may be used to axially position PWR fuel assemblies that are shorter than the canister cavity length to facilitate handling.

1.3.2 Site Specific Spent Fuel

This section describes fuel assembly characteristics and configurations, which are unique to specific reactor sites. These site specific content configurations result from conditions that occurred during reactor operations, participation in research and development programs (testing programs intended to improve reactor operations), and from the placement of control components or other items within the fuel assembly.

Site specific fuel assembly configurations are either shown to be bounded by the analysis of the standard design basis fuel assembly configuration of the same type (PWR or BWR), or are shown to be acceptable contents by specific evaluation of the configuration.

Unless specifically excepted, site specific fuel must meet all of the conditions specified for the design basis fuel presented in Section 1.3.1 above. Site specific fuels are also described in Section 2.1.3.

1.3.2.1 Maine Yankee Site Specific Spent Fuel

The configurations of Maine Yankee site specific fuel assemblies that have been evaluated and found to be acceptable contents are:

- Fuel assemblies with up to 176 fuel rods removed from the assembly lattice.
- Fuel assemblies with fuel rods replaced with stainless steel rods, solid Zircaloy rods or fuel rods enriched to 1.95 wt % ²³⁵U.
- Fuel assemblies with burnable poison rods replaced with hollow Zircaloy tubes.
- Fuel assemblies that are variably enriched with a maximum fuel rod enrichment of 4.21 wt % ²³⁵U and that also have a maximum planar average enrichment of 3.99 wt % ²³⁵U.
- Fuel assemblies with variable enrichment and/or annular axial blankets.
- Fuel assemblies with a control element assembly inserted.
- Fuel assemblies with an instrument thimble inserted in the center guide tube.
- Fuel assemblies with up to two fuel rods inserted in any or all of the guide tubes.
- Fuel assemblies with inserted nonfuel components, including start-up sources.
- Consolidated fuel.
- Fuel assemblies having up to 100% of the rods damaged in each assembly.
- Fuel assemblies having a burnup of greater than 45,000 MWD/MTU but less than 50,000 MWD/MTU.

These site specific fuel configurations are evaluated against the limits established for the UMS[®] Storage System based on the design basis fuel. The site specific fuel is either shown to be bounded by the evaluation of the design basis fuel or is separately evaluated to establish limits which are maintained by preferential loading administrative controls. Where applicable to specific configurations, the preferential loading controls are described in Section 2.1.3.1.1. The preferential loading controls take advantage of design features of the UMS[®] Storage System to allow the loading of fuel configurations that may have higher burnup or additional hardware or fuel source material that is not specifically considered in the design basis fuel evaluation.

The Transportable Storage Canister loading procedures will indicate that the loading of a fuel configuration with removed fuel or poison rods, damaged or consolidated fuel in a Maine Yankee fuel can, or fuel with burnup greater than 45,000, but less than 50,000, MWD/MTU is administratively controlled in accordance with Section 2.1.3.1 and Table 2.1.3.1-1. As shown in the table, only one consolidated fuel lattice is loaded in any single canister. Preferential loading positions in the canister basket are shown in Figure 2.1.3.1-1.

THIS PAGE INTENTIONALLY LEFT BLANK

1.4 Generic Vertical Concrete Cask Arrays

A typical ISFSI storage pad layout for 20 concrete casks is provided in Figure 1.4-1. As shown in this figure, roads parallel the sides of the pad to facilitate transfer of the concrete cask from the transporter to the designated storage position on the pad. Loaded concrete casks are placed in the vertical position on the pad in a linear array. Array sizes could accommodate from 1 to more than 200 casks. Figure 1.4-1 shows typical spacing and representative site dimensions. Actual spacing and dimensions are dependent on the general site layout, access roads, site boundaries, and transfer equipment selection, but must conform to the spacing or dimension requirements established in Section 8.1.3 of the Operating Procedures.

The reinforced concrete foundation is capable of sustaining the transient loads from the air pad and the general loads of the stored casks. If necessary, the pad can be constructed in phases to specifically meet utility-required expansions.

Figure 1.4-1 Typical ISFSI Storage Pad Layout

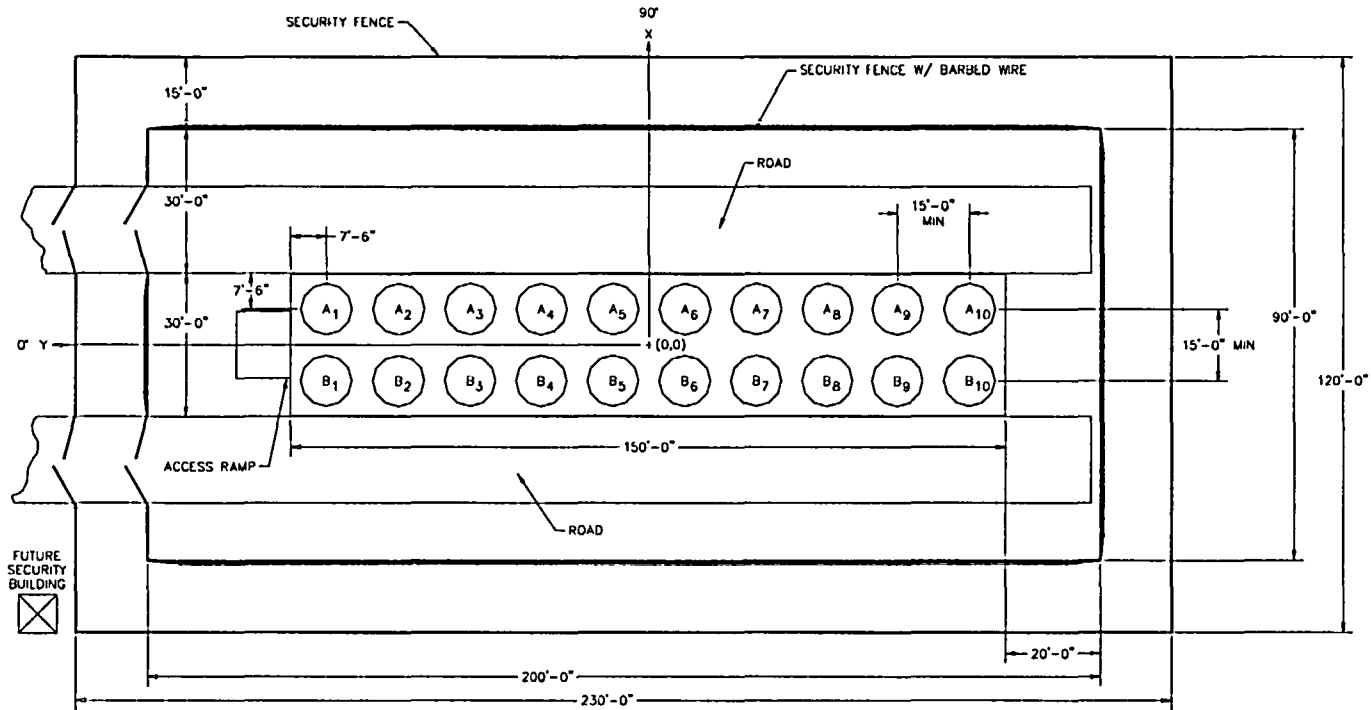

1.5 UMS[®] Universal Storage System Compliance with NUREG-1536

The design of the UMS[®] Universal Storage System meets the regulatory requirements and acceptance criteria specified in NUREG-1536 as shown in Table 1.5-1. This table provides a compliance matrix that shows the specified regulatory requirements and acceptance criteria of NUREG-1536, and the location in the UMS[®] Universal Storage System Safety Analysis Report where each of the requirements or criteria are addressed.

Table 1.5-1 NUREG-1536 Compliance Matrix

Chapter 1 – General Description			
Area	Requirement	Acceptance Criteria	Description of Compliance
1. General Description and Operational Features	The application must present a general description and discussion of the DCSS, with special attention to design and operating characteristics, unusual or novel design features, and principal safety considerations. [10 CFR Part 72.24(b)]	The applicant should provide a broad overview and a general, non-proprietary description (including illustrations) of the DCSS, clearly identifying the functions of all components and providing a list of those components classified by the applicant as being "important to safety."	A general description of the system is provided in Section 1.2. Safety classifications are provided in Table 2.3-1.
2. Drawings	Structures, systems, and components (SSCs) important to safety must be described in sufficient detail to enable reviewers to evaluate their effectiveness. [10 CFR Part 72.24(c)(3)]	The applicant should provide non-proprietary drawings of the storage system, of sufficient detail, that an interested party can ascertain its major design features and general operations.	Drawings of the system are provided in Section 1.8.
3. DCSS Contents	The applicant must provide specifications for the contents expected to be stored in the DCSS (normally spent fuel). These specifications may include, but not be limited to, type of spent fuel (i.e., boiling-water reactor (BWR), pressurized-water reactor (PWR), or both), maximum allowable enrichment of the fuel before any irradiation, burnup (i.e., megawatt-days/metric ton Uranium), minimum acceptable cooling time of the spent fuel before storage in the DCSS (aged at least 1 year), maximum heat designed to be dissipated, maximum spent fuel loading limit, condition of the spent fuel (i.e., intact assembly or consolidated fuel rods), weight and nature of non-spent fuel contents, and inert atmosphere requirements. [10 CFR Part 72.2(a)(1) and 10 CFR Part 72.236(a)]	The applicant should characterize the fuel and other radioactive wastes expected to be stored in the DCSS. If the potential exists that the DCSS will be used to store degraded fuel, the SAR should include a discussion of how the sub-criticality and retrievability requirements will be maintained.	A description of the contents to be stored is presented in Section 2.1, and Tables 2.1.1-1 and 2.1.2-1.

Table 1.5-1 NUREG-1536 Compliance Matrix (continued)

Chapter 1 – General Description			
Area	Requirement	Acceptance Criteria	Description of Compliance
4. Qualifications of the Applicant	The application must include the technical qualifications of the applicant to engage in the proposed activities. Qualifications should include training and experience. [10 CFR Part 72.24(j), 10 CFR Part 72.28(a)]	The reviewer should ensure that the applicant has clearly identified the roles and responsibilities that the DCSS designer, vendor, and other agents, such as potential licensees, fabricators, and contractors will have in the review process. Verify that the applicant has provided clear evidence demonstrating that they are qualified to engage in the proposed activities. In addition, verify that the applicant has delineated the responsibilities for all those who will be involved in the construction and operation of the DCSS if known. The reviewer should ensure that the applicant has specifically defined activities which they will not perform.	Applicant qualifications are discussed in Section 1.6.
5. Quality Assurance	The safety analysis report (SAR) must include a description of the applicant's quality assurance (QA) program, with reference to implementing procedures. This description must satisfy the requirements of 10 CFR Part 72, Subpart G, and must be applied to DCSS SSC that are important to safety throughout all design, fabrication, construction, testing, operations, modifications and decommissioning activities. These implementing procedures need not be explicitly included in the application. [10 CFR Part 72.24(n)]	Verify that the applicant has described the proposed QA program, citing the applicable implementing procedures. This description should satisfy all requirements of 10 CFR Part 72, Subpart G, that apply to the design, fabrication, construction, testing, operation, modification, and decommissioning of the DCSS SSCs that are important to safety.	Applicant QA program is presented in Chapter 13.
6. Consideration of 10 CFR Part 71 Requirements Regarding Transportation	If the DCSS under consideration has previously been reviewed and certified for use as a transportation cask, the application must include a copy of the Certificate of Compliance issued for the DCSS under 10 CFR Part 71, including drawings and other documents referenced in the certificate. [10 CFR 72.230(b)]	If the DCSS under review has previously been evaluated for use as a transportation cask, the submittal should include the Part 71 Certificate of Compliance and associated documents.	The transport application for issuance of a Part 71 Certificate of Compliance is discussed in Section 1.0.

Table 1.5-1 NUREG-1536 Compliance Matrix (continued)

Chapter 2 – Principal Design Criteria			
Area	Requirement	Acceptance Criteria	Description of Compliance
1. Structures, Systems, and Components (SSC) Important to Safety	<p>The applicant must identify all SSC that are important to safety, and describe the relationships of non-important to safety SSC on overall DCSS performance. [10 CFR 72.24(c)(3) and 72.44(d)]</p> <p>The applicant must specify the design bases and criteria all SSC that are important to safety. [10 CFR 72.24(c)(1), 72.24(c)(2), 72.120(a), and 72.236(b)]</p>	<p>The applicant should discuss the general configuration of the DCSS, and should provide an overview of specific components and their intended functions. In addition, the applicant should identify those components deemed to be important to safety, and should address the safety functions of those components in terms of how they meet the general design criteria and regulatory requirements discussed above.</p> <p>Additional information concerning specific functional requirements for individual DCSS components are addressed in the subsequent chapters of this SRP.</p>	<p>The safety classification of system components are described in Table 2.3-1.</p> <p>The design bases and criteria for the system are specified in Table 2-1. Detailed design criteria are presented in Section 2.2.</p>

Table 1.5-1 NUREG-1536 Compliance Matrix (continued)

Chapter 2 – Principal Design Criteria			
Area	Requirement	Acceptance Criteria	Description of Compliance
<p>2. Design Bases for Structures, Systems, and Components Important to Safety</p> <p>a. Spent Fuel Specifications</p>	<p>The applicant must provide the range of specifications for the spent fuel to be stored in the DCSS. These specifications should include, but are not to be limited to: the type of spent fuel (i.e., boiling-water reactor (BWR), pressurized-water reactor (PWR), or both); content, weight, dimensions and configurations of the fuel; maximum allowable enrichment of the fuel before any irradiation; maximum fuel burnup (i.e., megawatt-days/mtu); minimum acceptable cooling time of the spent fuel before storage in the DCSS (aged at least 1 year); maximum heat load to be dissipated; maximum spent fuel elements to be loaded; spent fuel condition (i.e., intact assembly or consolidated fuel rods); and any inerting atmosphere requirements. [10 CFR 72.2(a)(1) and 72.236(a)]</p>	<p>Detailed descriptions of each of the items listed below are generally found in specific sections of the SAR; however, a brief description of these areas, including a summary of the analytical techniques used in the design process, should also be captured in Section 2 of the SAR. This description gives reviewers a perspective on how specific DCSS components interact to meet the regulatory requirements of 10 CFR Part 72. This discussion should be non-proprietary since it may be used to familiarize interested persons with the design features and bounding conditions of operation of a given DCSS.</p> <p>The applicant should define the range and types of spent fuel or other radioactive materials that the DCSS is designed to store. In addition, these specifications should include, but are not to be limited to, the type of spent fuel (i.e., boiling-water reactor (BWR), pressurized-water reactor (PWR), or both), weights of the stored materials, dimensions & configurations of the fuel, maximum allowable enrichment of the fuel before any irradiation, burnup (i.e., megawatt-days/mtu), minimum acceptable cooling time of the spent fuel before storage in the DCSS (aged at least 1 year), maximum heat designed to be dissipated, maximum number of spent fuel elements, condition of the spent fuel (i.e., intact assembly or consolidated fuel rods), inerting atmosphere requirements, and the maximum amount of fuel permitted for storage in the DCSS. For DCSSs that will be used to store radioactive materials other than spent fuel, that is, activated components associated with a spent fuel assembly (e.g., control rods, BWR fuel channels), the applicant should specify the types and amounts of radionuclides, heat generation and the relevant source strengths and radiation energy spectra permitted for storage in the DCSS.</p>	<p>Specifications of the spent fuel contents are provided in Section 2.1. Specific physical parameters of the design basis fuel are listed in Tables 2.1.1-1 and 2.1.2-1.</p>

Table 1.5-1 NUREG-1536 Compliance Matrix (continued)

Chapter 2 – Principal Design Criteria			
Area	Requirement	Acceptance Criteria	Description of Compliance
<p>3. Design Bases for Structures, Systems, and Components Important to Safety</p> <p>b. External Conditions</p>	<p>The design bases for SSC important to safety must reflect an appropriate consideration of environmental conditions associated with normal operations, as well as design considerations for both normal and accident conditions and the effects of natural phenomena events. [10 CFR 72.122(b)]</p>	<p>The SAR should define the bounding conditions under which the DCSS is expected to operate. Such conditions include both normal and off-normal environmental conditions, as well as accident conditions. In addition, the applicant should consider the effects of natural events, such as tornadoes, earthquakes, floods, and lightning strikes. The effects of such events are addressed in individual chapters of the SRP (e.g., the effects of an earthquake on the DCSS structural components are addressed in Chapter 3, "Structural Analysis").</p>	<p>The environmental conditions and natural phenomena considered as design bases are described in Section 2.2.</p>
<p>3. Design Criteria for Safety Protection Systems</p> <p>a. General</p>	<p>The DCSS must be designed to safely store the spent fuel for a minimum of 20 years and to permit maintenance as required. [10 CFR 72.236(g)]</p> <p>SSC important to safety must be designed, fabricated, erected, and tested to quality standards commensurate with the importance to safety of the function to be performed. [10 CFR 72.122(a)]</p> <p>The applicant must identify all codes and standards applicable to the SSC. [10 CFR 72.24(c)(4)]</p>	<p>The SAR should define an expected lifetime for the cask design. The staff has accepted a minimum of 20 years as consistent with the licensing period. The applicant should also briefly describe the proposed quality assurance (QA) program, and applicable industry codes and standards, that will be applied to the design, fabrication, construction, and operation of the DCSS.</p> <p>In establishing normal and off-normal conditions applicable to the design criteria for DCSS designs, applicants should account for actual facility operating conditions. Design considerations should therefore reflect normal operational ranges, including any seasonal variations or effects.</p>	<p>The codes and standards of design and construction of the system and the design life are specified in Table 2-1, and discussed in Section 3.1.2.</p>

Table 1.5-1 NUREG-1536 Compliance Matrix (continued)

Chapter 2 – Principal Design Criteria			
Area	Requirement	Acceptance Criteria	Description of Compliance
<p>3. Design Criteria for Safety Protection Systems</p> <p>b. Structural</p>	<p>SSC that are important to safety must be designed to accommodate the combined loads of normal operations, accidents, and natural phenomena events with an adequate margin of safety. [10 CFR 72.24(c)(3), 72.122(b), and 72.122(c)]</p> <p>The design-basis earthquake must be equivalent to or exceed the safe shutdown earthquake of a nuclear plant at sites evaluated under 10 CFR Part 100. [10 CFR 72.102(f)]</p> <p>The DCSS must maintain confinement of radioactive material within the limits of 10 CFR Part 72 and Part 20, under normal, off-normal, and credible accident conditions. [10 CFR 72.236(l)]</p> <p>The DCSS must be designed and fabricated so that the spent fuel is maintained in a subcritical condition all under all credible normal, off-normal, and accident conditions. [10 CFR 72.124(a) and 72.236(c)]</p> <p>The spent fuel cladding must be protected during storage against degradation that leads to gross ruptures, or the fuel must be otherwise confined such that degradation of the fuel during storage will not pose operational safety problems with respect to its removal from storage. [10 CFR 72.122(h)(1)]</p> <p>Storage systems must be designed to allow ready retrieval of spent fuel waste for further processing or disposal. [10 CFR 72.122(l)]</p>	<p>The SAR should define how the DCSS structural components are designed to accommodate combined normal, off-normal, and accident loads, while protecting the DCSS contents from significant structural degradation, criticality, and loss of confinement, while preserving retrievability. This discussion is generally a summary of the analytical techniques and calculational results from the detailed analysis discussed in SAR Section 3 and should be presented in a non-proprietary forum.</p>	<p>A discussion of the structural design criteria are presented in Section 2.2. Combined loadings are addressed specifically in Section 2.2.5, and in Tables 2.2-1 and 2.2-2.</p> <p>The design-basis earthquake is specified in Section 2.2.3 in accordance with 10 CFR 72.102 criteria.</p> <p>Analyses show that the system maintains adequate margins of safety during normal (Section 3.4.4.1), off-normal (Section 11.1) and accident condition (Section 11.2) events, therefore, confinement of the radioactive material is assured.</p> <p>As the system maintains adequate structural margins of safety during normal, off-normal and accident condition events, criticality control is assured based on the analyses presented in Chapter 6.</p> <p>The maximum allowable cladding temperatures are specified in Tables 2-1 and 4.1-3. The temperature results for the fuel cladding listed in Tables 4.1-4 and 4.1-5 show that the allowable cladding temperatures are not exceeded. Therefore, the fuel cladding is protected against degradation during storage.</p> <p>As described in Section 1.2, the system is designed to be readily retrievable and transported off site as necessary for further processing or disposal.</p>

Table 1.5-1 NUREG-1536 Compliance Matrix (continued)

Chapter 2 – Principal Design Criteria			
Area	Requirement	Acceptance Criteria	Description of Compliance
3. Design Criteria for Safety Protection Systems c. Thermal	<p>Each spent fuel storage or handling system must be designed with a heat removal capability having testability and reliability consistent with its importance to safety. [10 CFR 72.128(a)(4)]</p> <p>The DCSS must be designed to provide adequate heat removal capacity without active cooling systems. [10 CFR 72.236(f)]</p>	<p>The applicant should provide a general discussion of the proposed heat removal mechanisms, including the reliability and verifiability of such mechanisms and any associated limitations. All heat removal mechanisms should be passive and independent of intervening actions under normal and off-normal conditions.</p>	<p>The testability of the heat removal capability of the storage system is described in Section 2.3.3.2. The reliability of the heat removal system is demonstrated in Chapter 4, and operating limits are established in Appendix A of the Amendment 3 Technical Specifications consistent with the temperature monitoring and routine surveillance described in Section 2.3.3.2 to ensure continued safe operation.</p> <p>As shown by the results of the thermal evaluation of the system reported in Tables 4.1-4 and 4.1-5, the storage system provides adequate heat removal through the passive cooling design features described in Section 1.2.1.3.</p>

Table 1.5-1 NUREG-1536 Compliance Matrix (continued)

Chapter 2 – Principal Design Criteria			
Area	Requirement	Acceptance Criteria	Description of Compliance
<p>3. Design Criteria for Safety Protection Systems</p> <p>d. Shielding/Confinement/Radiation Protection</p>	<p>The proposed DCSS design must provide radiation shielding and confinement features that are sufficient to meet the requirements of 10 CFR 72.104 and 72.106. [10 CFR 72.126(a), 72.128(a)(2), 72.128(a)(3), and 72.236(d)]</p> <p>During normal operations and other anticipated occurrences, the annual dose equivalent to any real individual who is located beyond the controlled area must not exceed 25 mrem to the whole body, 75 mrem to the thyroid, and 25 mrem to any other organ as a result of exposure to (1) planned discharges to the general environment of radioactive materials except radon and its decay products, (2) direct radiation from operations of the ISFSI or monitored retrievable storage (MRS), and (3) any other radiation from uranium fuel cycle operations within the region. [10 CFR 72.24(d), 72.104(a), and 72.236(d)]</p> <p>Any individual located at or beyond the nearest boundary of the controlled area shall not receive a dose greater than 5 rem to the whole body or any organ from any design-basis accident. The minimum distance from the spent fuel handling and storage facilities to the nearest boundary of the controlled area shall be 100 meters. [10 CFR 72.24(d), 72.24(m), 72.106(b), and 36(d)]</p> <p>The DCSS must be designed to provide redundant sealing of confinement systems. [10 CFR 72.236(e)]</p> <p>Storage confinement systems must have the capability for continuous monitoring in a manner such that the licensee will be able to determine when corrective action needs to be taken to maintain safe storage conditions. [10 CFR 72.122(h)(4) and 72.128(a)(1)]</p> <p>The DCSS design must include inspections, instrumentation and/or control (I&C) systems to monitor the SSC that are important to safety over anticipated ranges for normal and off-normal operation. In addition, the applicant must identify those control systems that must remain operational under accident conditions. [10 CFR 72.122(i)]</p>	<p>The applicant should describe those features of the cask that protect occupational workers and members of the public against direct radiation dosages and releases of radioactive material, and minimize the dose after any off-normal or accident conditions.</p>	<p>The confinement design features are described in Section 2.3.2.1, while the radiation shielding design features are described in Section 2.3.5.</p> <p>Section 10.4 presents the necessary minimum site boundary distances from an array of loaded storage systems to meet the controlled area dose limits.</p> <p>As stated in Section 10.2.2, there is no postulated accident condition that would result in a release of radioactive materials. Therefore, the accident dose limit is met.</p> <p>The redundant sealing features of the confinement system are presented in Section 2.3.2.1.</p> <p>As described in Section 2.3.1, the system is fully welded and can operate through all postulated normal, off-normal, and accident events while confining of the stored radioactive material. Therefore, continuous monitoring is not required.</p> <p>Appendix A, Section A 3.1.6 and Section A 5.4 specify the surveillance requirements for the system under normal conditions and after an accident, respectively. These activities are specified to ensure that the system is operated within its design parameters at all times.</p>

Table 1.5-1 NUREG-1536 Compliance Matrix (continued)

Chapter 2 – Principal Design Criteria			
Area	Requirement	Acceptance Criteria	Description of Compliance
3. Design Criteria for Safety Protection Systems e. Criticality	<p>Spent fuel transfer and storage systems must be designed to remain subcritical under all credible conditions. [10 CFR 72.124(a) and 72.236(c)]</p> <p>When practicable, the DCSS must be designed on the basis of favorable geometry, permanently fixed neutron-absorbing materials (poisons), or both. Where solid neutron-absorbing materials are used, the design shall allow for positive means to verify their continued efficacy. [10 CFR 72.124(b)]</p>	<p>The SAR should address the mechanisms and design features that enable the DCSS to maintain spent fuel in a subcritical condition under normal, off-normal, and accident conditions.</p>	<p>The criticality safety design criteria for the system are presented in Section 2.3.4.</p>

Table 1.5-1 NUREG-1536 Compliance Matrix (continued)

Chapter 2 – Principal Design Criteria			
Area	Requirement	Acceptance Criteria	Description of Compliance
<p>3. Design Criteria for Safety Protection Systems</p> <p>f. Operating Procedures</p>	<p>The DCSS must be compatible with wet or dry spent fuel loading and unloading procedures. [10 CFR 72.236(h)]</p> <p>Storage systems must be designed to allow ready retrieval of spent fuel for further processing or disposal. [10 CFR 72.122(l)]</p> <p>The DCSS must be designed to minimize the quantity of radioactive waste generated. [10 CFR 72.24(f) and 72.128(a)(5)]</p> <p>The applicant must describe equipment and processes proposed to maintain control of radioactive effluents. [10 CFR 72.24(l)(2)]</p> <p>To the extent practicable, the DCSS must be designed to facilitate decontamination. [10 CFR 72.236(l)]</p> <p>The applicant must establish operational restrictions to meet the limits defined in 10 CFR Part 20 and to ensure that radioactive materials in effluents and direct radiation levels associated with ISFSI operations will remain as low as is reasonably achievable (ALARA). [10 CFR 72.24(e) and 72.104(b)]</p>	<p>The applicant should provide potential licensees with guidance regarding the content of normal, off-normal, and accident response procedures. Cautions regarding both loading, unloading, and other important procedures should be mentioned here. Applicants may choose to provide model procedures to be used as an aid for preparing detailed site-specific procedures.</p>	<p>The operating procedures for the system are presented in Chapter 8, and include procedures for wet loading and unloading operations. Discussion is provided on the development of operating procedures for dry cask handling facilities.</p> <p>The procedures include methods for retrieving the spent fuel after storage for off-site transport or for return to the spent fuel pool.</p> <p>The decommissioning considerations of the system are described in Section 2.4. Operation of the system generates no radioactive waste, other than a limited amount of protective clothing and tools used during loading operations that could be easily disposed or decontaminated.</p> <p>The radiation protection design features of the system are presented in Section 2.3.5. Operating procedures for the system include provisions for controlling potential effluents from the system.</p> <p>The canister is designed to facilitate decontamination, as described in Section 2.3.5.3.</p> <p>Fuel assembly specifications are provided in Appendix B, Section B 2.1.1 to ensure that doses from direct radiation are maintained ALARA. There are no radioactive effluents from the canister or concrete cask in storage operations.</p>

Table 1.5-1 NUREG-1536 Compliance Matrix (continued)

Chapter 2 – Principal Design Criteria			
Area	Requirement	Acceptance Criteria	Description of Compliance
3. Design Criteria for Safety Protection Systems g. Acceptance Tests and Maintenance	<p>The DCSS design must permit testing and maintenance as required. [10 CFR 72.236(g)]</p> <p>SSC that are important to safety must be designed, fabricated, erected, tested, and maintained to quality standards commensurate with the importance to safety of the function to be performed. [10 CFR 72.24(c), 72.122(a), 72.122(f), and 72.128(a)(1)]</p>	<p>The applicant should identify the general commitments and industry codes and standards used to derive acceptance, maintenance, and periodic surveillance tests used to verify the capability of DCSS components to perform their designated functions. In addition, the applicant should discuss the methods used to assess the need for such tests with regard to specific components.</p>	<p>The acceptance tests and maintenance program for the system are provided in Chapter 9, including the associated commitments to industry standards and/or NRC regulations.</p>
3. Design Criteria for Safety Protection Systems g. Acceptance Tests and Maintenance	<p>The DCSS design must permit testing and maintenance as required. [10 CFR 72.236(g)]</p> <p>SSC that are important to safety must be designed, fabricated, erected, tested, and maintained to quality standards commensurate with the importance to safety of the function to be performed. [10 CFR 72.24(c), 72.122(a), 72.122(f), and 72.128(a)(1)]</p>	<p>The applicant should identify the general commitments and industry codes and standards used to derive acceptance, maintenance, and periodic surveillance tests used to verify the capability of DCSS components to perform their designated functions. In addition, the applicant should discuss the methods used to assess the need for such tests with regard to specific components.</p>	<p>The acceptance tests and maintenance program for the system are provided in Chapter 9, including the associated commitments to industry standards and/or NRC regulations.</p>

Table 1.5-1 NUREG-1536 Compliance Matrix (continued)

Chapter 2 – Principal Design Criteria			
Area	Requirement	Acceptance Criteria	Description of Compliance
<p>3. Design Criteria for Safety Protection Systems</p> <p>h. Decommissioning</p>	<p>The DCSS must be compatible with wet or dry unloading facilities. [10 CFR 72.236(h)]</p> <p>The DCSS must be designed for decommissioning. Provisions must be made to facilitate decontamination of structures and equipment and to minimize the quantity of radioactive wastes, contaminated equipment, and contaminated materials at the time the ISFSI is permanently decommissioned. [10 CFR 72.24(f), 72.130, and 72.236(I)]</p> <p>The applicant must provide information concerning the proposed practices and procedures for decontaminating the site and facilities and for disposing of residual radioactive materials after all spent fuel has been removed. Such information must provide reasonable assurance that decontamination and decommissioning will adequately protect the health and safety of the public. [10 CFR 72.24(q) and 72.30(a)]</p>	<p>Casks should be designed for ease of decontamination and eventual decommissioning. The applicant should describe the features of the design that support these two activities.</p>	<p>Decommissioning of the system is discussed in Section 2.4.</p>

Table 1.5-1 NUREG-1536 Compliance Matrix (continued)

Chapter 3 – Structural Evaluation		
Area	Regulatory Requirement	Description of Compliance
1. Structures, Systems, and Components Important to Safety	Structures, systems, and components (SSC) important to safety must meet the regulatory requirements established in 10 CFR 72.24(c)(3) and (4), as well as 10 CFR 72.122(a), (b), and (c).	
	10 CFR 72.24(c)(3) Contents of Application: Descriptions of Components Important to Safety	Component descriptions are provided in Section 1.2. Description of the structural design is provided in Section 3.1.1.
	10 CFR 72.24(c)(4) Contents of Application: Applicable Codes and Standards	The applicable codes and standards are specified in Table 2-1 and Sections 3.1.1 and 3.1.2.
	10 CFR 72.122(a) Overall Requirements: Quality Standards	The quality standards of the system are provided in Table 2.3-1.
	10 CFR 72.122(b) Overall Requirements: Protection Against Environmental Conditions and natural Phenomena	The system is evaluated structurally for normal operating loads in Sections 3.4.4 and 3.4.5. Off-normal and accident loads are evaluated in Sections 11.1 and 11.2, respectively.
10 CFR 72.122(c) Overall Requirements: Protection Against Fires and Explosions	The system is evaluated for fire and explosive loadings in Section 11.2.	

Table 1.5-1 NUREG-1536 Compliance Matrix (continued)

Chapter 3 – Structural Evaluation		
Area	Regulatory Requirement	Description of Compliance
2. Radiation, Shielding, Confinement, and Subcriticality	Radiation shielding, confinement, and subcriticality must meet the regulatory requirements defined in 10 CFR 72.24(d); 10 CFR 72.124(a); and 10 CFR 72.236(c), (d), and (l).	The margins of safety for normal conditions are listed in Sections 3.4.4.1 and 3.4.4.2. Off-normal and accident condition margins of safety are presented in Sections 11.1 and 11.2, respectively. Adequate safety margins are maintained for all events, ensuring the mitigation of accident consequences, and maintaining the shielding, confinement, and criticality analyses presented in the SAR.
	10 CFR 72.24(d) Contents of Application: Margins of Safety / Mitigation of Accident Consequences	
	10 CFR 72.124(a) Criteria for Nuclear Criticality Safety: Design for Criticality Safety	
	10 CFR 72.236(c) Specific Requirements for Spent Fuel Storage Cask Approval: Maintain Subcritical Configuration	
	10 CFR 72.236(d) Specific Requirements for Spent Fuel Storage Cask Approval: Radiation Protection	
10 CFR 72.236(l) Specific Requirements for Spent Fuel Storage Cask Approval: Maintain Confinement	Confinement of the spent fuel is discussed in Sections 7.2 and 7.3.	
3. Removal of Spent Fuel	As stated in 10 CFR 72.122(f) and (h)(l), the storage system design must allow ready retrieval of spent fuel without posing operational safety problems.	The system is not adversely affected by normal, off-normal, or accident condition events as demonstrated in Sections 3.4.4.1, 3.4.4.2, 11.1 and 11.2. Operating procedures for removing spent fuel from the system are presented in Sections 8.2 and 8.3.
4. Design Basis Earthquake	As stated in 10 CFR 72.102(f), the design-basis earthquake (DBE) must be equal to or greater than the safe-shutdown earthquake (SSE) of nuclear plant sites previously evaluated under 10 CFR Part 100 or, in the case of sites licensed before the implementation of 10 CFR Part 100, developed under Topic III-2 of the Systematic Evaluation Program (SEP).	As described in Section 2.2.3.1, the system is designed for a seismic event that meets the regulatory requirements.
5. Minimum Lifetime	As stated in 10 CFR 72.24(c) and 10 CFR 72.236(g), the analysis and evaluation of the structural design and performance must demonstrate that the cask system will allow storage of spent fuel for a minimum of 20 years with an adequate margin of safety.	Section 1.1 and Table 2-1 specify a 50-year design life for the system.

Table 1.5-1 NUREG-1536 Compliance Matrix (continued)

Chapter 3 – Structural Evaluation		
Area	Regulatory Requirement	Description of Compliance
6. Reinforced Concrete Structures	Reinforced concrete structures may have a role in shielding, form ventilation passages and weather enclosures, and providing protection against natural phenomena and accidents. The pertinent regulations include 10 CFR 72.24(c) and 10 CFR 72.182(b) and (c).	<p>A general description of the Vertical Concrete Cask (VCC) is provided in Section 1.2.1.3. The design criteria for the VCC is presented in Table 2-1. The design bases considered in the structural evaluation of the VCC are presented in Section 2.2.5.1.</p> <p>This requirement is applicable to the ISFSI, not the storage system.</p> <p>This requirement is applicable to the ISFSI, not the storage system.</p>
	10 CFR 72.24(c) Contents of Application: Design Criteria, Design Bases, Component Descriptions, Codes and Standards	
	10 CFR 72.182(b) Design for Physical Protection: Design Bases / Design Criteria	
	10 CFR 72.182(c) Design for Physical Protection: Security System Description	

Table 1.5-1 NUREG-1536 Compliance Matrix (continued)

Chapter 3 – Structural Evaluation		
Area	Acceptance Criteria	Description of Compliance
<p>1. Confinement Cask a. Steel Confinement Cask</p>	<p>The structural design, fabrication, and testing of the confinement system and its redundant sealing system should comply with an acceptable code or standard, such as Section III of the Boiler and Pressure Vessel Code (B&PV) promulgated by the American Society of Mechanical Engineers (ASME). (The NRC has accepted use of either Subsection NB or Subsection NC of this code.) Other design codes or standards may be acceptable depending on their application.</p> <p>i. The NRC staff evaluates the proposed limitations on allowable stresses and strains in the confinement cask, reinforced concrete components, system components important to safety, and other components subject to review, by comparison with those specified in applicable codes and standards. Where certain proposed load combinations will exceed the accepted limits for localized points on the structure, the applicant should provide adequate justification to show that the deviation will not affect the functional integrity of the structure.</p> <p>ii. The NRC has accepted the use of applicable subsections of the ASME B&PV Code, Division 1, for components used within the confinement cask but not integrated with it. This includes the "basket" structure used in casks to restrain and position multiple fuel elements.</p>	<p>As specified in Section 3.1.2, the canister and basket structure are designed in accordance with the ASME Code, Section III, Division I, 1995 Edition.</p> <p>The canister is designed in accordance with Subsection NB of the ASME Code, while the basket structure is designed in accordance with Subsection NG criteria.</p> <p>A list of exceptions from the ASME code is provided in Appendix B, Table B3-1.</p>

Table 1.5-1 NUREG-1536 Compliance Matrix (continued)

Chapter 3 – Structural Evaluation		
Area	Acceptance Criteria	Description of Compliance
b. Concrete Containments	<p>i. ACI 359 (also designated as Section III, Division 2, of the ASME B&PV Code, Subsection CC) constitutes an acceptable standard for prestressed and reinforced concrete that is an integral component of a radioactive material containment vessel that must withstand internal pressure in operation or testing.</p> <p>ii. If ACI 359 pertains to a given ISFSI structure, it applies to all aspects of the design, material selection, fabrication, and construction of that structure. The NRC has not accepted the proposed substitution of elements from ACI 318 or ACI 349 for any portion of ACI 359 with regard to the structure of an ISFSI. ISFSI structures to which ACI 359 applies shall also meet the minimum functional requirements of ANSI/ANS-57.9 for subject areas not specifically addressed in ACI 359.</p>	The UMS system does not utilize concrete containment vessels. Thus, ACI-359 is not applicable.
2. Reinforced Concrete (RC) Structures Important to Safety, but not within the Scope of ACI 359	The NRC accepts the use of ACI 349 for the design, material selection and specification, and construction of all reinforced concrete structures that are not addressed within the scope of ACI 359. However, in such instances, the design, material selection and specification, and construction must also meet any additional or more stringent requirements given in ANSI/ANS-57.9, as incorporated by reference in NRC Regulatory Guide (RG) 3.60. Section V of this chapter provides additional guidance regarding specific review procedures.	As stated in Section 3.1.2, the Vertical Concrete Cask is designed in accordance with ACI-349 and ANSI/ANS-57.9.
3. Other Reinforced Concrete Structures Subject to Approval	The NRC accepts the use of either ACI 318 or ACI 349 for reinforced concrete structures that are subject to approval but are not important to safety. Section V of this chapter provides additional guidance regarding specific review procedures.	The UMS system has no concrete structures other than that addressed in #2 above.

Table 1.5-1 NUREG-1536 Compliance Matrix (continued)

Chapter 3 – Structural Evaluation		
Area	Acceptance Criteria	Description of Compliance
<p>4. Other System Components Important to Safety</p>	<p>The NRC accepts the use of ANSI/ANS-57.9 (together with the codes and standards cited therein) as the basic reference for ISFSI structures important to safety that are not designed in accordance with the Section III of the ASME B&PV Code. However, both the lifting equipment design and the devices for lifting system components that are important to safety must comply with American National Standards Institute (ANSI) Standard N14.6.</p> <p>The NRC accepts the load combinations shown in Table 3-1 for structures not designed under either Section III of the ASME B&PV Code or ACI 359. These load combinations are based upon ANSI/ANS-57.9, with supplemental definition of terms and combinations.</p> <p>The principal codes and standards include the following references that may apply to steel structures and components:</p> <ul style="list-style-type: none"> a. American Institute of Steel Construction (AISC), "Specification for Structural Steel Buildings — Allowable Stress Design and Plastic Design" b. AISC, "Load and Resistance Factor Design Specification for Structural Steel Buildings" c. American Welding Society, "Structural Welding Code Steel," AWS D1.1 d. American Society of Civil Engineers, "Minimum Design Loads for Buildings and Other Structures," ASCE 7 [however, note that load combinations established on the basis of ANSI/ANS-57.9 (DCSS SRP Table 3-1) are to be used] e. ACI 349-85, Appendix B, for embedments or 10.14 for composite compression sections, as applicable, when constructed of structural steel embedded in reinforced concrete 	<p>The lifting devices of the UMS system are evaluated in accordance with NUREG-0612 and ANSI N14.6, as specified in Section 3.1.2.</p>

Table 1.5-1 NUREG-1536 Compliance Matrix (continued)

Chapter 3 – Structural Evaluation		
Area	Acceptance Criteria	Description of Compliance
5. Other Components Subject to NRC Approval	For structural design and construction of other components subject to NRC approval, the principal codes and standards include the following: <ul style="list-style-type: none"> a. ASCE 7 b. Uniform Building Code (UBC) c. AISC, "Specification for Structural Steel Buildings—Allowable Stress Design and Plastic Design" d. AISC "Code of Standard Practice for Steel Buildings and Bridges" e. ASME B&PV Code, Section VIII 	Not applicable. All components of the system subject to NRC approval are covered by the acceptance criteria specified in the previous sections.

Table 1.5-1 NUREG-1536 Compliance Matrix (continued)

Chapter 4 – Thermal Evaluation		
Area	Regulatory Requirement	Description of Compliance
1. Minimum Lifetime	10 CFR Part 72 requires an analysis and evaluation of DCSS thermal design and performance to demonstrate that the cask will permit safe storage of the spent fuel for a minimum of 20 years.	Section 1.1 and Table 2-1 specify a 50-year design life for the system. Tables 4.1-4 and 4.1-5 demonstrate that the system's temperatures are maintained within their allowable limits.
2. Spent Fuel Cladding Protection	The spent fuel cladding must be protected against degradation that may lead to gross ruptures.	Tables 4.1-4 and 4.1-5 demonstrate that the fuel cladding temperatures are maintained within allowable limits.
3. Thermal Structures, Systems, and Components	Thermal structures, systems, and components important to safety must be described in sufficient detail to permit evaluation of their effectiveness. Applicable thermal requirements are identified, in part, in 10 CFR 72.24(c)(3), 72.24(d), 72.122(h)(1), 72.122(l), 72.128(a)(4), 72.236(f), 72.236(g), and 72.236(h).	The discussion of the thermal design features of the system is presented in Section 4.1.
	10 CFR 72.24(c)(3) Contents of Application: Descriptions of Components Important to Safety	Tables 4.1-4 and 4.1-5 demonstrate that the temperatures of SSCs are maintained within allowable limits for all components of the system, including the fuel cladding.
	10 CFR 72.24(d) Contents of Application: Margins of Safety / Mitigation of Accident Consequences	Therefore, the system is not adversely affected by normal, off-normal, or accident condition events.
	10 CFR 72.122(h)(1) Overall Requirements: Confinement Barriers and Systems	The temperatures of the system are maintained within allowable limits, and do not preclude retrieval of spent fuel from the system.
	10 CFR 72.122(l) Overall Requirements: Retrievalability	
	10 CFR 72.128(a)(4) Criteria for Spent Fuel Storage and Handling: Testable Heat Removal Capacity	As specified in Section 9.1.7 and Appendix A, Section 3.1.6, the air temperature at the outlet vents is measured to ensure proper operation of the passive heat removal system.
	10 CFR 72.236(f) Specific Requirements for Spent Fuel Storage Cask Approval: Passive Heat Removal	Section 1.1 and Table 2-1 specify a 50-year design life for the system. Tables 4.1-4 and 4.1-5 demonstrate that the system's temperatures are maintained within their allowable limits.
	10 CFR 72.236(g) Specific Requirements for Spent Fuel Storage Cask Approval: Minimum 20-year Lifetime	
10 CFR 72.236(h) Specific Requirements for Spent Fuel Storage Cask Approval: Wet/Dry Loading and Unloading Compatibility	The operating procedures for the system, presented in Chapter 8, include procedures for wet and dry loading and unloading operations. A discussion is provided for development of dry loading and unloading procedures for dry cask handling facilities.	

Table 1.5-1 NUREG-1536 Compliance Matrix (continued)

Chapter 4 – Thermal Evaluation		
Area	Acceptance Criteria	Description of Compliance
1. Long-term Cladding Temperatures	Fuel cladding (zircaloy) temperature at the beginning of dry cask storage should generally be below the allowable temperature of 400°C (752°F) per ISG-11, Rev. 2.	As shown in Tables 4.1-4 and 4.1-5, the fuel cladding temperatures are maintained below allowable temperature limits for zircaloy clad fuel as determined in accordance with ISG 11, Rev. 2.
2. Short Term Cladding Temperatures	Fuel cladding temperature should generally be maintained below 570°C (1058°F) for short-term, off-normal and accident conditions (PNL 4835). For fuel transfer operations (e.g., vacuum drying of the cask or dry transfer), the temperature should generally be maintained below 400°C (752°F). (ISG-11, Rev 2)	As shown in Tables 4.1-4 and 4.1-5, the fuel cladding temperatures are maintained below 570°C (1058°F) for short-term, off-normal and accident conditions. For transfer operations, the fuel cladding temperatures are maintained below 400°C (752°F).
3. Maximum Internal Pressure	The maximum internal pressure of the cask should remain within its design pressures for normal, off-normal, and accident conditions assuming rupture of 1 percent, 10 percent, and 100 percent of the fuel rods, respectively. Assumptions for pressure calculations include release of 100 percent of the fill gas and 30 percent of the significant radioactive gases in the fuel rods.	The maximum normal condition pressure calculation is presented in Section 4.4.5. The accident condition pressure calculation is presented in Section 11.2.1. The off-normal condition is bounded by the accident condition, which assumes 100% failure of the cladding.
4. Maximum Material Temperatures	Cask and fuel materials should be maintained within their minimum and maximum temperature criteria for normal, off-normal, and accident conditions in order to enable components to perform their intended safety functions.	Tables 4.1-4 and 4.1-5 demonstrate that the temperatures are maintained within allowable limits for all components of the system, including the fuel cladding. Therefore, the system is not adversely affected by normal, off-normal, or accident condition events.
5. Fuel Cladding Protection	The spent fuel cladding is the primary structural component that is used to ensure that the spent fuel is contained in a known geometric configuration.	As concluded in ISG-11, Rev. 2, creep under normal conditions of storage will not cause gross rupture of the cladding, and the geometric configuration of the spent fuel will be preserved provided that the maximum cladding temperature does not exceed 400°C (752°F).
6. Long-Term Cladding Damage	Creep is the dominant mechanism for cladding deformation under normal conditions of storage. The relatively high temperatures, differential pressures, and corresponding hoop stress on the cladding will result in permanent creep deformation of the cladding over time.	A temperature limit of 400°C (752°F) for normal conditions of storage and for short-term storage operations will limit cladding hoop stresses and creep and limit the amount of soluble hydrogen available to form radial hydrides. (ISG-11, Rev. 2)
7. Passive Cooling	The cask system should be passively cooled. [10 CFR 72.236(f)]	As stated in Sections 1.2 and 4.1, the system is passively cooled.
8. Thermal Operating Limits	The thermal performance of the cask should be within the allowable design criteria specified in SAR Section 2 (e.g., materials, decay heat specifications) and SAR Section 3 (e.g., thermal stress analysis) for normal, off-normal, and accident conditions.	The thermal stress analyses of the canister and Vertical Concrete Cask for normal conditions are provided in Sections 3.4.4.1.1 and 3.4.4.2.3, respectively. The system is evaluated for off-normal thermal loading in Section 11.1.2, and the system is analyzed for accident thermal loading in Sections 11.2.6, 11.2.7 and 11.2.13.

Table 1.5-1 NUREG-1536 Compliance Matrix (continued)

Chapter 5 – Shielding Evaluation		
Area	Regulatory Requirement	Description of Compliance
I. Shielding System Description	10 CFR Part 72 requires that spent fuel radioactive waste storage and handling systems be designed with suitable shielding to provide adequate radiation protection under both normal and accident conditions. Consequently, the DCSS application must describe the shielding structures, systems, and components (SSCs) important to safety in sufficient detail to allow the NRC staff to thoroughly evaluate their effectiveness. It is the responsibility of the vendor, the facility owner, and the NRC staff to analyze such SSCs with the objective of assessing the impact of direct radiation doses on public health and safety.	A general description of the system is provided in Section 1.2, with a detailed description of the shielding features of the system provided in Section 5.1.

Table 1.5-1 NUREG-1536 Compliance Matrix (continued)

Chapter 5 – Shielding Evaluation		
Area	Regulatory Requirement	Description of Compliance
2. Protection During Accidents	In addition, SSCs important to safety must be designed to withstand the effects of both credible accidents and severe natural phenomena without impairing their capability to perform their safety functions. The applicable shielding requirements are identified, in part, in 10 CFR 72.24(c)(3), 72.24(d), 72.104(a), 72.106(b), 72.122(b), 72.122(c), 72.128(a)(2), and 72.236(d).	
	10 CFR 72.24(c)(3) Contents of Application: Descriptions of Components Important to Safety	A description of the shielding components of the system is provided in Section 5.1.
	10CFR 72.24(d) Contents of Application: Margins of Safety / Mitigation of Accident Consequences	The design basis dose rates for accident conditions are listed in Section 10.2.2. Specific details of the dose rate due to the tip-over accident are presented in Section 11.2.12.
	10 CFR 72.104(a) Criteria for Radioactive Materials in Effluents and Direct Radiation from an ISFSI or MRS: Annual Site Boundary Dose Limit	The controlled area boundary dose calculations and minimum site boundary distances are presented in Section 10.4.
	10 CFR 72.106(b) Controlled Area of an ISFSI or MRS: Design Basis Accident Site Boundary Dose Limit	The accident condition dose rates are discussed in Section 10.2.2.
	10 CFR, 72.122(b) Overall Requirements: Protection Against Environmental Conditions and Natural Phenomena	Evaluation of the system for off-normal and accident condition events is provided in Sections 11.1 and 11.2. The radiological consequences of each event are addressed.
	10 CFR 72.122(c) Overall Requirements: Protection Against Fires and Explosions	The radiological consequences of a fire accident are provided in Section 11.2.6. The radiological consequences of an explosion are provided in Section 11.2.5.
	10 CFR 72.128(a)(2) Criteria for Spent Fuel ... Storage and Handling: Radiation Protection	The dose rate results demonstrating the radiation protection features of the system are presented in Section 5.1.
	10 CFR 72.236(d) Specific Requirements for Spent Fuel Storage Cask Approval: Radiation Protection	As described above, the normal condition controlled area boundary dose rates are provided in Section 10.4. The accident condition doses are discussed in Section 10.2.2.

Table 1.5-1 NUREG-1536 Compliance Matrix (continued)

Chapter 5 – Shielding Evaluation		
Area	Acceptance Criteria	Description of Compliance
1. Minimum Distance from Controlled Area Boundary	The minimum distance from each spent fuel handling and storage facility to the controlled area boundary must be at least 100 meters. The “controlled area” is defined in 10 CFR 72.3 as the area immediately surrounding an ISFSI or monitored retrievable storage (MRS) facility, for which the licensee exercises authority regarding its use and within which ISFSI operations are performed.	As described in Section 10.4, the minimum allowable controlled area boundary distance for a single cask is 100 meters.
2. Controlled Area Boundary Dose Limits	The cask vendor must show that, during both normal operations and anticipated occurrences, the radiation shielding features of the proposed DCSS are sufficient to meet the radiation dose requirements in Sections 72.104(a). Specifically, the vendor must demonstrate this capability for a typical array of casks in the most bounding site configuration. For example, the most bounding configuration might be located at the minimum distance (100 meters) to the controlled area boundary, without any shielding from other structures or topography.	Section 10.4 presents the controlled area boundary dose rate evaluation for a typical array configuration. The minimum allowable controlled area boundary distance is 100 meters without taking credit for shielding provided by any intermediate structures or topography.
3. ALARA	Dose rates from the cask must be consistent with a well-established “as low as reasonably achievable” (ALARA) program for activities in and around the storage site.	The dose rates for the system are presented in Section 5.1. These dose rates are within the allowables specified in Section 10.2.1, which are consistent with ALARA principles.
4. Maximum Accident Controlled Area Boundary Dose	After a design-basis accident, an individual at the boundary or outside the controlled area shall not receive a dose greater than 5 rem to the whole body or any organ.	Section 10.2.2 indicates that the controlled area boundary dose as a result of an accident will not exceed 5 rem.
5. Occupational Dose Limits	The proposed shielding features must ensure that the DCSS meets the regulatory requirements for occupational and radiation dose limits for individual members of the public, as prescribed in 10 CFR Part 20, Subparts C and D.	Occupational dose estimates for typical loading operations are provided in Section 10.3. In practice, occupational doses would be controlled on a site-specific basis by the operator of the ISFSI.

Table 1.5-1 NUREG-1536 Compliance Matrix (continued)

Chapter 6 – Criticality Evaluation		
Area	Regulatory Requirement	Description of Compliance
	Spent fuel storage systems must be designed to remain subcritical unless at least two unlikely independent events occur. Moreover, the spent fuel cask must be designed to remain subcritical under all credible conditions. Regulations specific to nuclear criticality safety of the cask system are specified in 10 CFR 72.124 and 72.236(c). Other pertinent regulations include 10 CFR 72.24(c)(3), 72.24(d), and 72.236(g). Normal and accident conditions to be considered are also identified in 10 CFR Part 72.	
	10 CFR 72.24(c)(3) Contents of Application: Descriptions of Components Important to Safety	A general description of the system is provided in Section 1.2, with a detailed description of the criticality safety features of the system provided in Section 6.1.
	10 CFR 72.24(d) Contents of Application: Margins of Safety / Mitigation of Accident Consequences	Section 6.4 presents the results of the criticality evaluation of the transfer cask and storage cask.
	10 CFR 72.124 Criteria for Nuclear Criticality Safety	The criteria for criticality safety are provided in Sections 2.3.4 and 6.1.
	10 CFR 72.236(c) Specific Requirements for Spent Fuel Storage Cask Approval: Maintain Subcritical Configuration	Section 6.4 presents the results of the criticality evaluation of the storage cask for the most credible reactive conditions.
	10 CFR 72.236(g) Specific Requirements for Spent Fuel Storage Cask Approval: Minimum 20-year Lifetime	Section 1.1 and Table 2-1 specify a 50-year design life for the system.

Table 1.5-1 NUREG-1536 Compliance Matrix (continued)

Chapter 6 – Criticality Evaluation		
Area	Acceptance Criteria	Description of Compliance
1. Subcriticality Margin	The multiplication factor (k_{eff}), including all biases and uncertainties at a 95-percent confidence level, should not exceed 0.95 under all credible normal, off-normal, and accident conditions.	As stated in Section 6.1, the maximum allowable multiplication factor (k_e) for the system is 0.95, including adjustment for all biases and uncertainties, as calculated in Section 6.5.
2. Double Contingency	At least two unlikely, independent, and concurrent or sequential changes to the conditions essential to criticality safety, under normal, off-normal, and accident conditions, should occur before an accidental criticality is deemed to be possible.	As stated in Section 6.1, the criticality analyses are performed for the most reactive credible configuration of the cask, at the highest enrichment, without credit for fuel burnup, and at the most reactive internal water moderator density, even though it is stated that water intrusion is not a credible event.
3. Criticality Design Features	When practicable, criticality safety of the design should be established on the basis of favorable geometry, permanent fixed neutron-absorbing materials (poisons), or both. Where solid neutron-absorbing materials are used, the design should provide for a positive means to verify their continued efficacy during the storage period.	As stated in Section 6.1, the criticality safety of the design is based on geometry and fixed neutron poisons. Recently proposed rule changes (Federal Register, June 9, 1998) include discussion clarifying the 10 CFR 72.124(b) requirement to verify the “continued efficacy” of neutron poisons as applicable only to wet storage systems, and not to dry, provided that the effectiveness of the poisons is demonstrated at the outset. Verification of the neutron absorbing materials effectiveness is discussed in Section 9.1.
4. Conservative Assumptions	Criticality safety of the cask system should not rely on use of the following credits: a. burnup of the fuel b. fuel-related burnable neutron absorbers c. more than 75 percent for fixed neutron absorbers when subject to standard acceptance tests.	Section 6.1 provides a list of conservative assumptions that are used in the criticality safety evaluation. No fuel burnup is assumed, and only 75% of the minimum ¹⁰ B loading on the neutron absorber plates is used. Also, no integral fuel burnable neutron absorbers, nor fission product neutron poisons, are considered in the analysis.

Table 1.5-1 NUREG-1536 Compliance Matrix (continued)

Chapter 7 – Confinement Evaluation		
Area	Regulatory Requirement	Description of Compliance
1. Description of Structures, Systems, and Components Important to Safety	The SAR must describe the confinement structures, systems, and components (SSCs) important to safety in sufficient detail to facilitate evaluation of their effectiveness. [10 CFR 72.24(c)(3) and 10 CFR 72.24(l)]	A general description of the system is provided in Section 1.2, with a detailed description of the confinement features of the system provided in Section 7.1.
2. Protection of Spent Fuel Cladding	The design must adequately protect the spent fuel cladding against degradation that might otherwise lead to gross ruptures during storage, or the fuel must be confined through other means such that fuel degradation during storage will not pose operational safety problems with respect to removal of the fuel from storage. [10 CFR 72.122(h)(1)]	As described in Sections 7.2.1 and 7.3, the integrity of the canister is maintained under normal and accident conditions. Therefore, the inert helium atmosphere is maintained in the canister, protecting the fuel cladding against degradation.
3. Redundant Sealing	The cask design must provide redundant sealing of the confinement boundary. [10 CFR 72.236(e)]	As described in Section 7.1.3.2, the canister is sealed after loading by means of a redundant closure system.
4. Monitoring of Confinement System	Storage confinement systems must allow continuous monitoring, such that the licensee will be able to determine when to take corrective action to maintain safe storage conditions. [10 CFR 72.122(h)(4) and 10 CFR 72.128(a)(1)]	The canister is a fully welded class 1 component designed and fabricated in accordance with ASME Code, Section III, Subsection NB. It is closed with a fully welded redundant closure system. Therefore, in accordance with previous regulatory guidance, monitoring of the confinement is not required.
5. Instrumentation	The design must provide instrumentation and controls to monitor systems that are important to safety over anticipated ranges for normal and off-normal operation. In addition, the applicant must identify those control systems that must remain operational under accident conditions. [10 CFR 72.122(l)]	As monitoring is not required, there is no instrumentation and controls required.
6. Release of Nuclides to the Environment	The applicant must estimate the quantity of radionuclides expected to be released annually to the environment. [10 CFR 72.24(l)(1)]	As described in Sections 7.2.1 and 7.3, the leaktight integrity of the confinement boundary is maintained during all postulated normal and accident condition events. Therefore, no release of radionuclides to the environment is credible.

Table 1.5-1 NUREG-1536 Compliance Matrix (continued)

Chapter 7 – Confinement Evaluation		
Area	Regulatory Requirement	Description of Compliance
<p>7. Evaluation of Confinement System</p>	<p>The applicant must evaluate the cask and its systems important to safety, using appropriate tests or other means acceptable to the Commission, to demonstrate that they will reasonably maintain confinement of radioactive material under normal, off-normal, and credible accident conditions. [10 CFR 72.236(l) and 10 CFR 72.24(d)]</p> <p>In addition, SSCs important to safety must be designed to withstand the effects of credible accidents and severe natural phenomena without impairing their capability to perform safety functions. [10 CFR 72.122(b)]</p>	<p>The confinement system is analyzed for normal conditions in Sections 3.4.2 and 3.4.4.1, and for off-normal, and accident conditions in Sections 11.1 and 11.2, respectively. The confinement capability of the canister closure is verified by helium leakage testing of the shield lid-to-canister shell weld following fuel loading as specified in Section 8.1 and the Technical Specifications.</p>
<p>8. Annual Dose Limit in Effluents and Direct Radiation from an Independent Spent Fuel Storage Installation (ISFSI)</p>	<p>During normal operations and anticipated occurrences, the annual dose equivalent to any real individual who is located beyond the controlled area must not exceed 25 mrem to the whole body, 75 mrem to the thyroid, and 25 mrem to any other organ. [10 CFR 72.104(a)]</p>	<p>The site boundary dose calculations and minimum site boundary distances are presented in Section 10.4.</p>

Table 1.5-1 NUREG-1536 Compliance Matrix (continued)

Chapter 7 – Confinement Evaluation		
Area	Acceptance Criteria	Description of Compliance
1. Redundant Sealing	The cask design must provide redundant sealing of the confinement boundary sealing surface. Typically, this means that field closures of the confinement boundary must either have double seal welds or double metallic O-ring seals.	As described in Section 7.1.3.2, the canister is sealed after loading by means of a redundant lid closure system.
2. Code Compliance	The confinement design must be consistent with the regulatory requirements, as well as the applicant's "General Design Criteria" reviewed in Chapter 2 of this SRP. The NRC staff has accepted construction of the primary confinement barrier in conformance with Section III, Subsections NB or NC, of the Boiler and Pressure Vessel (B&PV) Code promulgated by the American Society of Mechanical Engineers (ASME). (This code defines the standards for all aspects of construction, including materials, design, fabrication, examination, testing, inspection, and certification required in the manufacture and installation of components.) In such instances, the staff has relied upon Section III to define the minimum acceptable margin of safety; therefore, the applicant must fully document and completely justify any deviations from the specifications of Section III. In some cases after careful and deliberate consideration, the staff has made exceptions to this requirement.	The codes and standards utilized for the confinement system design are specified in Section 7.1.1. ASME Code, Section III, Subsection NB is utilized for the design and fabrication of the canister.
3. Maximum Allowable Leakage Rates	The applicant must specify the maximum allowed leakage rates for the total primary confinement boundary and redundant seals. (Applicants frequently display this information in tabular form, including the leakage rate of each seal.) In addition, the applicant's leakage analysis should be consistent with the principles specified in the "American National Standard for Leakage Tests on Packages for Shipment of Radioactive Materials" (ANSI N14.5). Generally, the allowable leakage rate must be evaluated for its radiological consequences and its effect on maintaining the necessary inert atmosphere within the cask.	As specified in Sections 7.2.1 and 7.3, leakage from the confinement system under normal, off-normal, and accident conditions is not credible because the canister is demonstrated to be leaktight.

Table 1.5-1 NUREG-1536 Compliance Matrix (continued)

Chapter 7 – Confinement Evaluation		
Area	Acceptance Criteria	Description of Compliance
<p>4. Monitoring and Surveillance</p>	<p>The applicant should describe the proposed monitoring capability and/or surveillance plans for mechanical closure seals. In instances involving welded closures, the staff has previously accepted that no closure monitoring system is required. This practice is consistent with the fact that other welded joints in the confinement system are not monitored. However, the lack of a closure monitoring system has typically been coupled with a periodic surveillance program that would enable the licensee to take timely and appropriate corrective actions to maintain safe storage conditions after closure degradation. The discussion in (a) below taken from chapter 2 of this SRP expands on the requirement for continuous monitoring.</p> <p>(a) Continuous Monitoring</p> <p>The Office of the General Counsel (OGC) has developed an opinion as to what constitutes “continuous monitoring” as required in 10 CFR Part 72.122(h)(4). The staff, in accordance with that opinion has concluded that both routine surveillance programs and active instrumentation meets the intent of “continuous monitoring.” Cask vendors may propose, as part of the SAR, either active instrumentation and/or surveillance to show compliance with 10 CFR Part 72.122(h)(4).</p> <p>The reviewer should note that some DCSS designs may contain a component or feature whose continued performance over the licensing period has not been demonstrated to staff with a sufficient level of confidence. Therefore the staff may determine that active monitoring instrumentation is required to provide for the detection of component degradation or failure. This particularly applies to components whose failure immediately affects or threatens public health and safety. In some cases the vendor or staff in order to demonstrate compliance with 10 CFR Part 72.122(h)(4), may propose a technical specification requiring such instrumentation as part of the initial use of a cask system. After initial use, and if warranted and approved by staff, such instrumentation may be discontinued or modified.</p>	<p>The system utilizes welded closures, as specified in Section 7.1. Therefore, no monitoring system is required.</p>

Table 1.5-1 NUREG-1536 Compliance Matrix (continued)

Chapter 7 – Confinement Evaluation		
Area	Acceptance Criteria	Description of Compliance
5. Non-Reactive Environment	The cask must provide a non-reactive environment to protect fuel assemblies against fuel cladding degradation, which might otherwise lead to gross rupture. Measures for providing a non-reactive environment within the confinement cask typically include drying, evacuating air and water vapor, and backfilling with a non-reactive cover gas (such as helium). For dry storage conditions, experimental data have not demonstrated an acceptably low oxidation rate for UO ₂ spent fuel, over the 20-year licensing period, to permit safe storage in an air atmosphere. Therefore, to reduce the potential for fuel oxidation and subsequent cladding failure, an inert atmosphere (e.g., helium cover gas) has been used for storing UO ₂ spent fuel in a dry environment. (See Chapter 8 of this SRP for more detailed information on the cover gas filling process.) Note that other fuel types, such as graphite fuels for the high-temperature gas-cooled reactors (HTGRs), may not exhibit the same oxidation reactions as UO ₂ fuels and, therefore, may not require an inert atmosphere. Applicants proposing to use atmospheres other than inert gas should discuss how the fuel and cladding will be protected from oxidation.	As described in Sections 7.0 and 7.1.1, the confinement system is vacuum dried, the dryness verified, and then backfilled with inert helium gas during loading operations.

Table 1.5-1 NUREG-1536 Compliance Matrix (continued)

Chapter 8 – Operating Procedures		
Area	Regulatory Requirement	Description of Compliance
Health and Safety	1. The applicant must develop operating procedures that adequately protect health and minimize danger to life or property. [10 CFR 72.40(a)(5)]	Operating procedures are provided in Chapter 8. Notes and Cautions are listed among the steps to emphasize steps important to maintaining health and safety.
ALARA	2. The applicant must establish operational restrictions to meet the regulatory requirements of 10 CFR Part 20 and objective limits that are as low as is reasonably achievable (ALARA) for radioactive materials in effluents and direct radiation levels associated with ISFSI operations. [10 CFR 72.104(b) and 10 CFR 72.24(e)]	Section 8.0 specifies that the procedures are developed to maintain occupational dose ALARA. Automated welding systems and temporary shielding are utilized to minimize worker dose during canister loading operations. Appendix A, Section A 3.2.2 specifies maximum external dose rates to maintain reasonable dose level within a cask array for routine surveillance and inspection activities.
Control of Radioactive Effluents	3. The applicant must describe all equipment and processes used to maintain control of radioactive effluents. [10 CFR 72.24(l)(2)]	As described in Section 8.0, there are no radioactive effluents in routine operations other than pool water and helium gas that are removed from the canister. These effluents are routinely handled in Licensee operations.
Written Procedures	4. The general licensee shall conduct activities related to storage of spent fuel in accordance with written procedures. [10 CFR 72.212(b)(9)] 5. Vendors seeking approval of a cask design shall ensure that written procedures and appropriate tests are established before initial use of the casks. In addition, the vendor must provide a copy of these procedures and tests to each prospective cask user. [10 CFR 72.234(f)]	Written procedures for the system are provided in Chapter 8. These procedures are intended to provide general operational guidance for use of the system. These procedures will be used by an ISFSI operator to develop detailed, site specific procedures for use of the system.
Wet or Dry Loading and Unloading Facilities	6. The cask must be compatible with wet or dry spent fuel loading and unloading facilities. [10 CFR 72.236(h)]	The system design is compatible with both wet or dry loading and unloading facilities.
Decontamination Features	7. To the extent practicable, the design of the cask must facilitate decontamination. [10 CFR 72.236(i)]	The canister is designed to facilitate decontamination as described in Section 2.3.5.3. As described in Section 8.1.1, the annulus between the canister and transfer cask is filled with clean water prior to placement in the fuel pool to minimize the potential for contamination of the surface of the canister.
Ready Retrieval of Spent Fuel	8. The design of storage systems must allow ready retrieval of spent fuel for further processing or disposal. [10 CFR 72.122(l)]	The procedure provided in Section 8.2 and 8.3 specify the steps necessary for retrieval of the spent fuel from the system for further processing or disposal.

Table 1.5-1 NUREG-1536 Compliance Matrix (continued)

Chapter 8 – Operating Procedures		
Area	Regulatory Requirement	Description of Compliance
Radioactive Waste Generation	9. The design of the cask must minimize the quantity of radioactive waste generated. [10 CFR 72.128(a)(5) and 10 CFR 72.24(f)]	Operation of the system generates no radioactive waste, other than a limited amount of protective clothing and tools used during loading operations that could be easily disposed or decontaminated.
Inspection, Maintenance, and Testing	10. The design of structures, systems, and components (SSCs) that are important to safety must permit inspection, maintenance, and testing. [10 CFR 72.122(f)]	Appendix A of the Amendment 3 Technical Specifications specifies the inspection and maintenance activities required for the system.
Scope of Application	1. Major operating procedures apply to the principal activities expected to occur during dry cask storage. The expected scope of activities for the SAR operating procedure descriptions is described in Section II, "Areas of Review" (<i>of the SRP</i>), as well as Section 8 of Regulatory Guide 3.61. Operating procedure descriptions should be submitted to address the cask design features and planned operations.	The operating procedures provided in Chapter 8 cover all planned operations of the system, including loading of spent fuel, placement of the system at the site, and unloading of the system.
Process Control and Hazard Mitigation	2. Operating procedure descriptions should identify measures to control processes and mitigate potential hazards that may be present during planned normal operations. Section V, "Review Procedures" (<i>of the SRP</i>), discusses previously identified processes and potential hazards.	The operating procedures provided in Chapter 8 include Notes and Cautions to indicate steps important to mitigate potential hazards.
Operating Controls and Limits	3. Operating procedure descriptions should ensure conformance with the applicable operating controls and limits described in the technical specifications provided in SAR Chapter 12.	The operating controls and limits specified in Chapter 12 are included with the appropriate procedures in Chapter 8.

Table 1.5-1 NUREG-1536 Compliance Matrix (continued)

Chapter 8 – Operating Procedures		
Area	Acceptance Criteria	Description of Compliance
Operational Planning	<p>4. Operating procedure descriptions should reflect planning to ensure that operations will fulfill the following acceptance criteria:</p> <p>a. Occupational radiation exposures will remain ALARA</p> <p>b. Effective measures will be taken to preclude potential unplanned and uncontrolled releases of radioactive materials</p> <p>c. Offsite dose rates will be maintained within the limits of 10 CFR Part 20 and 10 CFR 72.104 for normal operations, and 10 CFR 72.106 for accident conditions.</p> <p>In addition, the operating procedure descriptions should support and be consistent with the bases used to estimate radiation exposures and total doses. (Refer to Chapter 10 of this SRP).</p>	<p>As stated in Section 8.0, the operating procedures are developed to support maintaining occupational doses ALARA.</p> <p>Sections 8.1.1 and 8.3 include steps to preclude releases of radioactive material during loading and unloading operations.</p> <p>Section 10.4 presents the site boundary dose rate evaluation, including the minimum controlled area boundary distance needed to meet an annual dose limit of 25 mrem for normal conditions. Section 10.2.2 indicates that the accident condition controlled area boundary dose will not exceed 5 rem to any organ.</p> <p>The operating procedures specified in Chapter 8, and the previous cask loading and unloading experience of NAC, support the calculation of occupational dose rates presented in Section 10.3.</p>

Table 1.5-1 NUREG-1536 Compliance Matrix (continued)

Chapter 8 – Operating Procedures		
Area	Acceptance Criteria	Description of Compliance
Surveillance, Maintenance, and Contingency Plans	<p>5. Operating procedure descriptions should include provisions for the following activities:</p> <p>a. testing, surveillance, and monitoring of the stored material and casks during storage and loading and unloading operations</p> <p>b. maintenance of casks and cask functions during storage</p> <p>c. contingency actions triggered by inspections, checks, observations, instrument readings, and so forth. (Some of these may involve off-normal conditions addressed in SAR Section 11.)</p>	<p>The testing and inspection requirements during loading and unloading operations are specified in Section 8.1 and 8.3. Section 9.2 specifies the inspection and maintenance activities required for the system during storage. The limits established in Appendix A, Section A3.0 and Appendix B, Section B3.0, are provided to ensure that the spent fuel is protected during loading and unloading operations.</p> <p>Normal operational maintenance and surveillance activities are specified in Section 9.2. These activities include contingency actions that may be required as a result of the inspection.</p>
Cladding Protection	<p>6. As required by 10 CFR 72.122(h)(1), the operating procedure descriptions should facilitate reducing the amount of water vapor and oxidizing material within the confinement cask to an acceptable level to protect the spent fuel cladding against degradation that might otherwise lead to gross ruptures.</p>	<p>As specified in Appendix A, Sections 3.1.2 and 3.1.3, the canister is vacuum dried to eliminate water, the cavity dryness is verified, and the cavity is then backfilled with inert helium gas during fuel loading operations to protect the fuel cladding against oxidation.</p>

Table 1.5-1 NUREG-1536 Compliance Matrix (continued)

Chapter 9 – Acceptance Test and Maintenance Program		
Area	Regulatory Requirement	Description of Compliance
1. Testing and Maintenance	a. The SAR must describe the applicant's program for preoperational testing and initial operations. [10 CFR 72.24(p)]	Section 9.1 presents the acceptance testing for the system.
	b. The cask design must permit maintenance as required. [10 CFR 72.236(g)]	Section 9.2 presents the maintenance activities for the system.
	c. Structures, systems, and components (SSCs) important to safety must be designed, fabricated, erected, tested, and maintained to quality standards commensurate with the importance to safety of the function they are intended to perform. [10 CFR 72.122(a), 10 CFR 72.122(d), 10 CFR 72.128(a)(1), and 10 CFR 72.24(c)]	The acceptance tests and maintenance activities presented in Sections 9.1 and 9.2 are performed to verify compliance with the design bases and criteria, and that the system continues to perform as designed.
	d. The applicant or licensee must establish a test program to ensure that all required testing is performed to meet applicable requirements and acceptance criteria. In addition, at least 30 days before the receipt of spent fuel, the licensee must submit to the NRC a report concerning the pre-operational test acceptance criteria and test results. [10 CFR 72.162 and 10 CFR 72.82(e)]	The testing and maintenance provided in Sections 9.1 and 9.2 are intended to be used by an ISFSI user in the development of site-specific programs.
	e. The applicant or licensee must evaluate the cask and its systems important to safety, using appropriate tests or other means acceptable to the Commission, to demonstrate that they will reasonably maintain confinement of radioactive material under normal, off-normal, and credible accident conditions. [10 CFR 72.236(l)]	The acceptance tests presented in Section 9.1 demonstrate that the system will maintain confinement of the spent fuel under normal, off-normal, and accident conditions.
	f. The applicant or licensee must inspect the cask to ascertain that there are no cracks, pinholes, uncontrolled voids, or other defects that could significantly reduce confinement effectiveness. [10 CFR 72.236(j)]	As described in Section 9.1.1, the canister is visually and non-destructively examined prior to use.
	g. The applicant must perform, and make provisions that permit the Commission to perform, tests that the Commission deems necessary or appropriate. [10 CFR 72.232(b)]	Provisions shall be made, as necessary, to facilitate additional NRC imposed testing as required.
	h. The general licensee must accurately maintain the record provided by the cask supplier showing any maintenance performed on each cask. This record must include evidence that any maintenance and testing have been conducted under an NRC-approved quality assurance (QA) program. [10 CFR 72.212(b)(8)] The applicant or licensee must assure that the casks are conspicuously and durably marked with a model number, unique identification number, and the empty weight. [10 CFR 72.236(k)]	Records of maintenance activities would be maintained by the ISFSI user, and thus are not applicable. As specified in Section 9.1.8, each system is to be marked with the model number, unique cask number, empty weight, and additional information.

Table 1.5-1 NUREG-1536 Compliance Matrix (continued)

Chapter 9 – Acceptance Test and Maintenance Program		
Area	Regulatory Requirement	Description of Compliance
2. Resolution of Issues Concerning Adequacy or Reliability	<p>The SAR must identify all SSCs important to safety for which the applicant cannot demonstrate functional adequacy and reliability through previous acceptable evidence. For this purpose, acceptable evidence may be established in any of the following ways:</p> <ul style="list-style-type: none"> • prior use for the intended purpose • reference to widely accepted engineering principles • reference to performance data in related applications <p>In addition, the SAR should include a schedule showing how the applicant or licensee will resolve any associated safety questions before the initial receipt of spent fuel. [10 CFR 72.24(i)]</p>	<p>As described in Sections 3.1 and 3.3, the design of the system is based on industry standard codes and standards for materials and margins of safety. The acceptance tests specified in Section 9.1 are performed to demonstrate the adequacy of each fabricated system in accordance with applied Codes and Standards.</p> <p>The system does not rely on any materials or design standards that lack acceptable evidence of functional adequacy.</p>
3. Cask Identification	<p>The applicant or licensee must conspicuously and durably mark the cask with a model number, unique identification number, and empty weight. [10 CFR 72.236(k)]</p>	<p>As specified in Section 9.1.8, each system is to be marked with the model number, unique cask number, empty weight, and additional information.</p>
Confinement System	<p>American Society of Mechanical Engineers (ASME), "Boiler and Pressure Vessel (B&PV) Code," Section III, Subsection NB or NC</p> <p>"American National Standard for Radioactive Materials— Leakage Tests on Packages for Shipment" (ANSI N14.5-1987)</p>	<p>As specified in Section 3.1.2, the canister is designed in accordance with the ASME Code, Section III, Subsection NB. Exceptions to the Code are provided in Appendix B, Table B3-1. The confinement system is leak tested in accordance with ANSI N14.5 following shield lid welding as specified in Appendix A, LCO 3.1.5.</p>
Confinement Internals (e.g., basket)	ASME B&PV Code, Section III, Subsection NG	As specified in Section 3.1.2, the basket structure is designed in accordance with the ASME Code, Section III, Subsection NG.
Metal Cask Overpack	ASME B&PV Code, Section VIII	Not applicable.
Concrete Cask Overpack	American Concrete Institute (ACI) Standards 318 and 349, as appropriate	As stated in Section 3.1.2, the concrete cask is designed in accordance with ACI-349 and ANSI/ANS-57.9.
Other Metal Structures	<p>ASME B&PV Code, Section III, Subsection NF</p> <p>American Institute of Steel Construction (AISC), "Manual of Steel Construction"</p>	Not applicable.

Table 1.5-1 NUREG-1536 Compliance Matrix (continued)

Chapter 10 – Radiation Protection		
Area	Regulatory Requirement	Description of Compliance
1. Effluent and Direct Radiation	<p>Criteria for radioactive material released due to effluents and direct radiation from an ISFSI or MRS are contained 10 CFR 72.104.</p> <p>10 CFR 72.104 Criteria for Radioactive Materials in Effluents and Direct Radiation from an ISFSI or MRS</p>	The controlled area boundary dose calculations and minimum controlled area boundary distances are presented in Section 10.4.
2. Occupational Exposures	<p>Criteria for Occupational Exposures are contained in 10 CFR 20.1201, 10 CFR 20.1207, 10 CFR 20.1208, and 10 CFR 20.1301</p> <p>10 CFR 20.1201 Occupational Dose Limits for Adults</p> <p>10 CFR 20.1207 Occupational Dose Limits for Minors</p> <p>10 CFR 20.1208 Dose to an Embryo/Fetus</p> <p>10 CFR 20.1301 Dose Limits for Individual Members of the Public</p>	Estimated occupational doses for typical loading operations are provided in Section 10.3. In practice, occupational doses would be controlled on a site-specific basis by the operator of the ISFSI.
3. Public Exposures	<p>Criteria for public exposures under normal and accident conditions are contained within. [10 CFR 72.104 and 10 CFR 72.106]</p> <p>10 CFR 72.104 Criteria for Radioactive Materials in Effluents and Direct Radiation from an ISFSI or MRS</p> <p>10 CFR 72.106 Controlled Area of an ISFSI or MRS</p>	<p>The controlled area boundary dose calculations and minimum site boundary distances are presented in Section 10.4.</p> <p>Section 10.2.2 indicates that the controlled area boundary dose as a result of an accident will not exceed 5 rem to any organ, exclusive of skin.</p>

Table 1.5-1 NUREG-1536 Compliance Matrix (continued)

Chapter 10 – Radiation Protection		
Area	Regulatory Requirement	Description of Compliance
4. ALARA	Criteria for ALARA are contained within 10 CFR 20.1101, 10 CFR 72.24(e), 10 CFR 72.104(b), and 10 CFR 72.126(a)	
	10 CFR 20.1101 Radiation Protection Programs	The description of the radiation protection and ALARA considerations of the system are provided in Section 10.1.
	10 CFR 72.24(e) Contents of Application: ALARA Features	
	10 CFR 72.104(b) Criteria for Radioactive Materials in Effluents and Direct Radiation from an ISFSI or MRS: Operational Restrictions	The design basis for radiation protection is presented in Section 10.2.
10 CFR 72.126(a) Criteria for Radiological Protection: Exposure Control	Operational methods utilized to provide radiation protection are discussed in Section 10.1.3.	

Table 1.5-1 NUREG-1536 Compliance Matrix (continued)

Chapter 10 – Radiation Protection		
Area	Acceptance Criteria	Description of Compliance
1. Design Criteria	Limitations on dose rates associated with direct radiation from the cask are established on the basis of the shielding and confinement evaluations in order to satisfy the regulatory requirements for public dose limits. As stated in 10 CFR Part 72.104, during normal operations and anticipated occurrences, the annual dose equivalent to a real individual located beyond the controlled area, must not exceed the limits discussed below.	The dose rate design criteria are specified in Section 10.2.1.
2. Occupational Exposures	a. dose limits for adults: 5 rem/yr (total effective dose equivalent) b. dose limits for minors: 0.5 rem/yr c. dose to an embryo or fetus (declared pregnant woman): 0.5 rem during entire pregnancy	Estimated occupational doses for typical loading operations are provided in Section 10.3. In practice, occupational doses would be controlled on a site-specific basis by the operator of the ISFSI.
3. Public Exposures	a. Normal Conditions: whole body: 25 mrem/yr thyroid: 75 mrem/yr other organ: 25 mrem/yr These doses include the cumulative effects of other nuclear fuel cycle facilities that may be at the same location as the storage system (i.e., the nuclear power plant) and apply to the limiting real individual of the general public residing at a permanent location nearest the facility. b. Accident Conditions and Natural Phenomenon Events 5 rem to the whole body or any organ of any individual located at or beyond the nearest boundary of the controlled area.	The controlled area boundary dose calculations and minimum controlled area boundary distances under normal conditions are presented in Section 10.4. Contribution to the controlled area boundary dose rate from other facilities co-located with the ISFSI are beyond the scope of the SAR, and are addressed on a site-specific basis by the ISFSI operator. Section 10.2.2 indicates that the controlled area boundary dose as a result of an accident will not exceed 5 rem to any organ, exclusive of skin.

Table 1.5-1 NUREG-1536 Compliance Matrix (continued)

Chapter 10 – Radiation Protection		
Area	Regulatory Requirement	Description of Compliance
4. ALARA	<p>As a minimum, the proposed ALARA policy must fulfill the following criteria:</p> <ul style="list-style-type: none"> a. To the extent practicable, the applicant should employ procedures and engineering controls that are founded upon sound radiation protection principles. b. Any design change should account for radiation protection, technological, and economical considerations. c. The applicant should have a written policy statement reflecting management commitment to maintain occupational and public exposures to radiation and radioactive material ALARA. 	<p>The description of the ALARA considerations of the system are provided in Section 10.1.</p> <p>The operating procedures provided in Chapter 8 are developed to keep occupational doses ALARA.</p>

Table 1.5-1 NUREG-1536 Compliance Matrix (continued)

Chapter 11 – Accident Analysis		
Area	Regulatory Requirement	Description of Compliance
1. Credible Accident and Natural Phenomena	Structures, systems, and components (SSC) important to safety must be designed to withstand credible accidents and natural phenomena without impairing their ability to perform safety functions. [10 CFR 72.24(d)(2); 10 CFR 72.122(b)(2), (3), (d), and (g)]	Analyses of the system for a variety of postulated off-normal and accident conditions are presented in Sections 11.1 and 11.2, respectively.
2. Controlled Area Boundary Dose	During normal operations and anticipated occurrences, the annual dose equivalent to any real individual who is located beyond the controlled area must not exceed 25 mrem to the whole body, 75 mrem to the thyroid and 25 mrem to any other organ as a result of exposure to the sources listed in the regulations. [10 CFR 72.104(a); 10 CFR 72.236(d); and 10 CFR 72.24(d)]	The controlled area boundary dose calculations and minimum controlled area boundary distances under normal conditions are presented in Section 10.4.
3. Design Basis Accident Dose	Dose Limits for Design-Basis Accidents require that any individual located on or beyond the nearest boundary of the controlled area shall not receive a dose greater than 5 rem to the whole body or any organ from any design basis accident. [10 CFR 72.106(b); 10 CFR 72.24(m); and 10 CFR 72.24(d)(2)]	Section 10.2.2 indicates that the controlled area boundary dose as a result of an accident will not exceed 5 rem to any organ, exclusive of skin.
4. Criticality Control	The spent fuel must be maintained in a subcritical condition under credible conditions. [10 CFR 72.236(c) and 10 CFR 72.124(a)]	Section 6.4 presents the results of the criticality evaluation of the storage cask for the most credible reactive conditions, including the consequences of the off-normal and accident condition events evaluated in Sections 11.1 and 11.2, respectively.
5. Confinement Control	The cask and its systems important to safety must be evaluated, using appropriate tests or by other means acceptable to the Commission, to demonstrate that they will reasonably maintain confinement of radioactive material under credible accident conditions. [10 CFR 72.236(l)]	As stated in Section 7.3, the confinement system maintains its integrity for all credible off-normal and accident conditions.
6. Ready Retrieval of Spent Fuel	Storage systems must allow ready retrieval of spent fuel for further processing or disposal. [10 CFR 72.122(l)]	The off-normal and accident condition analyses presented in Sections 11.1 and 11.2 demonstrate that the spent fuel contents are protected during off-normal and accident conditions. Therefore, retrieval of the spent fuel from the system is not impacted by these postulated events.

Table 1.5-1 NUREG-1536 Compliance Matrix (continued)

Chapter 11 – Accident Analysis		
Area	Regulatory Requirement	Description of Compliance
7. Monitoring Systems	Instrumentation and control systems must be provided to monitor systems that are important to safety over anticipated ranges for normal operation and off-normal operation. Those instruments and control systems that must remain operational under accident conditions must be identified in the Safety Analysis Report. [10 CFR 72.122(i)]	The system utilizes temperature monitoring instrumentation but utilizes routine inspection and surveillance to verify proper thermal operation of the system. The confinement system is fully welded and is leak tested to leaktight criteria as specified in Appendix A, Section A3.1.5. No seal monitoring is required.
8. Surveillance	Where instrumentation and control systems are not appropriate, storage confinement systems must have the capability for continuous monitoring in a manner such that the licensee will be able to determine when corrective action needs to be taken to maintain safe storage conditions. [72.122(h)(4)]	No active, continuous monitoring systems are required. Licensee radiological monitoring programs assure ISFSI operations meet 10 CFR 72.104 and 72.106 requirements.

Table 1.5-1 NUREG-1536 Compliance Matrix (continued)

Chapter 11 – Accident Analysis		
Area	Acceptance Criteria	Description of Compliance
1. Dose Limits for Off-Normal Events	<p>During normal operations and anticipated occurrences, the requirements specified in 10 CFR Part 20 must be met. In addition the annual dose equivalent to any individual located beyond the controlled area must not exceed 25 mrem to the whole body, 75 mrem to the thyroid, and 25 mrem to any other organ as a result of exposure to the following sources:</p> <ul style="list-style-type: none"> a. planned discharges to the general environment of radioactive materials (with the exception of radon and its decay products) b. direct radiation from operations of the independent spent fuel storage installation (ISFSI) c. any other cumulative radiation from uranium fuel cycle operations (i.e., nuclear power plant) in the affected area 	<p>The controlled area boundary dose calculations and minimum controlled area boundary distances under normal conditions are presented in Section 10.4. No off-normal events are postulated that would result in a controlled area boundary dose in excess of the normal condition analysis.</p>
2. Dose Limit for Design-Basis Accidents	<p>Any individual located at or beyond the nearest controlled area boundary must not receive a dose greater than 5 rem to the whole body or any organ from any design-basis accident.</p>	<p>Section 10.2.2 indicates that the controlled area boundary dose as a result of an accident will not exceed 5 rem to any organ, exclusive of skin.</p>
3. Criticality	<p>The spent fuel must be maintained in a subcritical condition under credible conditions (i.e., k_{eff} equal to or less than 0.95). At least two unlikely, independent, and concurrent or sequential changes must be postulated to occur in the conditions essential to nuclear criticality safety before a nuclear criticality accident is possible (double contingency).</p>	<p>Section 6.4 presents the results of the criticality evaluation of the storage cask for the most credible reactive conditions, including the consequences of the off-normal and accident condition events evaluated in Sections 11.1 and 11.2, respectively.</p> <p>As stated in Section 6.1, the criticality analyses are performed for the most reactive credible configuration of the cask, at the highest enrichment, without credit for fuel burnup, and at the most reactive internal water moderator density, even though it is stated that water intrusion is not a credible event.</p>

Table 1.5-1 NUREG-1536 Compliance Matrix (continued)

Chapter 11 – Accident Analysis		
Area	Acceptance Criteria	Description of Compliance
4. Confinement	The cask and its systems important to safety must be evaluated, using appropriate tests or by other means acceptable to the Commission, to demonstrate that they will reasonably maintain confinement of radioactive material under credible accident conditions.	As stated in Section 7.3, the confinement system maintains its integrity for all credible off-normal and accident conditions.
5. Retrievability	Retrievability is the capability to return the stored radioactive material to a safe condition without endangering public health and safety. This generally means ensuring that any potential release of radioactive materials to the environment or radiation exposures is not in excess of the limits in 10 CFR 20 or 10 CFR 72.122(h)(5). ISFSI and MRS storage systems must be designed to allow ready retrieval of the stored spent fuel or high level waste (MRS only) for compliance with 10 CFR 72.122(l).	The off-normal and accident condition analyses presented in Sections 11.1 and 11.2 demonstrate that the spent fuel contents are protected during off-normal and accident conditions. Therefore, retrieval of the spent fuel from the system is not impacted by these postulated events.
6. Instrumentation	The SAR must identify all instruments and control systems that must remain operational under accident conditions.	The system does not utilize instrumentation and control systems, but utilizes routine inspection and surveillance to verify proper operation of the system.

Table 1.5-1 NUREG-1536 Compliance Matrix (continued)

Chapter 12 – Operating Controls and Limits	
Regulatory Requirement	Description of Compliance
1. General Requirement for Technical Specifications	
<p>The applicant shall propose technical specifications (complete with acceptable bases and adequate justification). These specifications must include the following five areas [10 CFR 72.44(c), 10 CFR 72.24(g), and 10 CFR 72.26]:</p> <ul style="list-style-type: none"> a. functional/operating limits, monitoring instruments, and limiting controls b. limiting conditions c. surveillance requirements d. design features e. administrative controls <p>Subpart E, "Siting Evaluation Factors," and Subpart F, "General Design Criteria," to 10 CFR Part 72, provide the bases for the cask system design and, hence, are applicable as bases for appropriate technical specifications.</p>	<p>Functional and operating limits are specified in Appendix A, Section 3.0 and in Appendix B, Sections B2.0 and B3.0.</p> <p>Limiting conditions for operation are specified in Appendix A, Section A3.0.</p> <p>Surveillance requirements are specified in Appendix A, Section A3.0.</p> <p>Design features are specified in Appendix B, Section B3.0.</p> <p>Administrative controls are specified in Appendix A, Section A5.0.</p>
2. Specific Requirements for Technical Specifications — Storage Cask Approval	
<p>As a condition of approval, the design, fabrication, testing, and maintenance of a spent fuel DCSS must comply with the requirements of 10 CFR 72.236. [10 CFR 72.234(a)]</p> <p>10 CFR 72.236 Specific Requirements for Spent Fuel Storage Cask Approval</p>	<p>The operating controls, limits, and surveillance activities specified in Appendix A are intended to ensure that the system is maintained within its design basis through all normal, off-normal, and accident conditions.</p>

Table 1.5-1 NUREG-1536 Compliance Matrix (continued)

Chapter 12 – Operating Controls and Limits	
Regulatory Requirement	Description of Compliance
<p>The applicant must provide specifications for the spent fuel to be stored in the DCSS. At a minimum, these specifications should include, but not be limited to the following details [10 CFR 72.236(a)]:</p> <ul style="list-style-type: none"> a. type of spent fuel (i.e., BWR, PWR, or both) b. maximum allowable enrichment of the fuel prior to any irradiation c. burn-up (i.e., megawatt-days/MTU) d. minimum acceptable cooling time of the spent fuel prior to storage in the DCSS (minimum 1 year) e. maximum heat that the DCSS system is designed to dissipate f. maximum spent fuel loading limit weights and dimensions g. condition of the spent fuel (i.e., intact assembly or consolidated fuel rods) h. inerting atmosphere requirements 	<p>Specifications for the spent fuel contents are provided in Appendix B, Tables B2-1 through B2-5.</p> <p>As specified in Appendix A, LCO 3.1.3, the canister is backfilled with helium gas to maintain an inert atmosphere for the spent fuel.</p>
<p>The applicant must provide design bases and design criteria for structures, systems, and components (SSCs) important to safety. [10 CFR 72.236(b)]</p>	<p>The design bases and criteria for the system are specified in Section 2.2.</p>
<p>The applicant must design and fabricate the DCSS so that the spent fuel will be maintained in a subcritical condition under credible conditions. [10 CFR 72.236(c)]</p>	<p>As shown in Section 6.4, the spent fuel is maintained in a subcritical configuration under all credible configurations.</p>
<p>The applicant must provide radiation shielding and confinement features that are sufficient to meet the requirements in 10 CFR 72.104 and 72.106 regarding radioactive material in effluents, direct radiation, and area control. [10 CFR 72.236(d) and 10 CFR Part 20]</p>	<p>The maximum external dose rates for the system are specified in Appendix A, Section A3.2.2. These limits are established to ensure that, for the minimum controlled area boundary distance presented in Section 10.4, the controlled area boundary annual dose will be maintained within allowable limits.</p>
<p>10 CFR 72.104 Criteria for Radioactive Materials in Effluents and Direct Radiation from an ISFSI or MRS</p>	
<p>10 CFR 72.106 Controlled Area of an ISFSI or MRS</p>	

Table 1.5-1 NUREG-1536 Compliance Matrix (continued)

Chapter 12 – Operating Controls and Limits	
Regulatory Requirement	Description of Compliance
<p>The applicant must design the DCSS to meet the following criteria:</p> <ul style="list-style-type: none"> • Provide redundant sealing of confinement systems. [10 CFR 72.236(e)] • Provide adequate heat removal capacity without active cooling systems. [10 CFR 72.236(f)] • Safely store the spent fuel for a minimum of 20 years and permit maintenance as required. [10 CFR 72.236(g)] • Facilitate decontamination to the extent practicable. [10 CFR 72.236(i)] 	<p>The redundant sealing features of the confinement system are presented in Section 2.3.2.1 and Chapter 7.</p> <p>As shown in Table 4.1-4, the system provides adequate heat removal through the passive cooling design features described in Section 4.1.</p> <p>Section 1.1 and Table 2-1 specify a 50-year design life for the system. Routine maintenance is permitted as specified by Section 9.2.</p> <p>Decommissioning of the system is discussed in Section 2.4.</p>
<p>The DCSS must be compatible with wet or dry spent fuel loading and unloading facilities. [10 CFR 72.236(h)]</p>	<p>The operating procedures for the system are presented in Chapter 8, and include procedures for wet and dry loading and unloading operations.</p>
<p>The applicant must inspect the DCSS to ascertain that there are no cracks, pinholes, uncontrolled voids, or other defects that could significantly reduce its confinement effectiveness. [10 CFR 72.236(j)]</p>	<p>As described in Section 9.1.1, the canister is visually and non-destructively examined prior to use.</p>
<p>The applicant must evaluate the DCSS, and its systems important to safety, using appropriate tests or other means acceptable to the Commission, to demonstrate that they will reasonably maintain confinement of radioactive material under normal, off-normal, and credible accident conditions. [10 CFR 72.236(l)]</p>	<p>The canister is analyzed for normal conditions in Section 3.4.4.1, and for off-normal and accident conditions in Sections 11.1 and 11.2, respectively. Because the canister maintains adequate positive margins of safety, the system will reasonably maintain confinement under all credible conditions.</p>

Table 1.5-1 NUREG-1536 Compliance Matrix (continued)

Chapter 13 – Quality Assurance	
Regulatory Requirement	Description of Compliance
According to 10 CFR 72.24, "Contents of Application: Technical Information," the application must include, at a minimum, a description that satisfies the requirements of 10 CFR Part 72, Subpart G, "Quality Assurance," with regard to the QA program to be applied to the design, fabrication, construction, testing, and operation of the DCSS SSCs important to safety. Moreover, Subpart G states that the licensee shall establish the QA program at the earliest practicable time consistent with the schedule for accomplishing the activities.	A synopsis of the NAC Quality Assurance Program is presented in Section 13.2. This program description is consistent with the 18 criteria specified in Subpart G. The NAC Quality Assurance Program is approved by the NRC under 10 CFR 71, Subpart H.

Table 1.5-1 NUREG-1536 Compliance Matrix (continued)

Chapter 13 – Quality Assurance		
Area	Acceptance Criteria	Description of Compliance
1. Quality Assurance Organization	The SAR should describe (and illustrate in an appropriate chart) the organizational structure, interrelationships, and areas of functional responsibility and authority for all organizations performing quality- and safety-related activities, including both the applicant's organization and principal contractors, if applicable. Persons or organizations responsible for ensuring that an appropriate QA program has been established and verifying that activities affecting quality have been correctly performed should have sufficient authority, access to work areas, and organizational freedom to carry out that responsibility.	The QA organization is described in Section 13.2.1. An organizational chart is provided in Figure 13.2-1.
2. Quality Assurance Program	The SAR should provide acceptable evidence that the applicant's proposed QA program will be well-documented, planned, implemented, and maintained to provide the appropriate level of control over activities and SSCs, consistent with their relative importance to safety.	The implementation of the QA program is described in Section 13.2.2.
3. Design Control	The SAR should describe the approach that the applicant will use to define, control, and verify the design and development of the DCSS. An effective design control program will provide assurance that the proposed DCSS will be appropriately designed and tested and will perform its intended function.	Design control is described in Section 13.2.3.
4. Procurement Document Control	Documents used to procure SSCs or services should include or reference applicable design bases and other requirements necessary to ensure adequate quality. To the extent necessary, these procurement documents should require that suppliers have a QA program consistent with the quality level of the SSCs or services to be procured.	Procurement document control is described in Section 13.2.4.
5. Instructions, Procedures, and Drawings	The SAR should define the applicant's proposed procedures for ensuring that activities affecting quality will be prescribed by, and performed in accordance with, documented instructions, procedures, or drawings of a type appropriate for the circumstances.	Procedures, instructions and drawings are described in Section 13.2.5.
6. Document Control	The SAR should define the applicant's proposed procedures for preparing, issuing, and revising documents that specify quality requirements or prescribe activities affecting quality. These procedures should provide adequate control to ensure that only the latest documents are used. In addition, the applicant's authorized personnel should carefully review and approve the accuracy of all documents and associated revisions before they are released for use.	Document control is described in Section 13.2.6.

Table 1.5-1 NUREG-1536 Compliance Matrix (continued)

Chapter 13 – Quality Assurance		
Area	Acceptance Criteria	Description of Compliance
7. Control of Purchased Material, Equipment, and Services	The SAR should define the applicant's proposed procedures for controlling purchased material, equipment, and services to ensure conformance with specified requirements.	Control of purchased items and services is described in Section 13.2.7.
8. Identification and Control of Materials, Parts, and Components	The SAR should define the applicant's proposed provisions for identifying and controlling materials, parts, and components to ensure that incorrect or defective SSCs are not used.	Identification and control of material, parts and components are described in Section 13.2.8.
9. Control of Special Processes	The SAR should describe the controls that the applicant will establish to ensure the acceptability of special processes (such as welding, heat treatment, nondestructive testing, and chemical cleaning) and that they are performed by qualified personnel using qualified procedures and equipment.	Control of special processes is described in Section 13.2.9.
10. Licensee Inspection	The SAR should define the applicant's proposed provisions for inspection of activities affecting quality to verify conformance with instructions, procedures, and drawings.	Inspection is described in Section 13.2.10.
11. Test Control	The SAR should define the applicant's proposed provisions for tests to verify that SSCs conform to specified requirements and will perform satisfactorily in service. The applicant should specify test requirements in written procedures, including provisions for documenting and evaluating test results. In addition, the applicant should establish qualification programs for test personnel.	Test control is described in Section 13.2.11.
12. Control of Measuring and Test Equipment	The SAR should define the applicant's proposed provisions to ensure that tools, gauges, instruments, and other measuring and testing devices are properly identified, controlled, calibrated, and adjusted at specified intervals.	Control of measuring and test equipment is described in Section 13.2.12.
13. Handling, Storage, and Shipping Control	The SAR should define the applicant's proposed provisions to control the handling, storage, shipping, cleaning, and preservation of SSCs in accordance with work and inspection instructions to prevent damage, loss, and deterioration.	Handling, storage and shipping are described in Section 13.2.13.

Table 1.5-1 NUREG-1536 Compliance Matrix (continued)

Chapter 13 – Quality Assurance		
Area	Acceptance Criteria	Description of Compliance
14. Inspection, Test, and Operating Status	The SAR should define the applicant's proposed provisions to control the inspection, test, and operating status of SSCs to prevent inadvertent use or bypassing of inspections and tests.	Inspection, test, and operating status are described in Section 13.2.14.
15. Nonconforming Materials, Parts, or Components	The SAR should define the applicant's proposed provisions to control the use or disposition of nonconforming materials, parts, or components.	Control of nonconforming items is described in Section 13.2.15.
16. Corrective Action	The SAR should define the applicant's proposed provisions to ensure that conditions adverse to quality are promptly identified and corrected and that measures are taken to preclude recurrence.	Corrective action is described in Section 13.2.16.
17. Quality Assurance Records	The SAR should define the applicant's proposed provisions for identifying, retaining, retrieving, and maintaining records that document evidence of the control of quality for activities and SSCs important to safety.	Records are described in Section 13.2.17.
18. Audits	The SAR should define the applicant's proposed provisions for planning, scheduling, and conducting audits to verify compliance with all aspects of the QA program, and to determine the effectiveness of the overall program. The SAR should clearly identify responsibilities and procedures for conducting audits, documenting and reviewing audit results, and designating management levels to review and assess audit results. In addition, the SAR should describe the applicant's provisions for incorporating the status of audit recommendations in management reports.	Audits are described in Section 13.2.18.

Table 1.5-1 NUREG-1536 Compliance Matrix (continued)

Decommissioning		
Area	Regulatory Requirement	Description of Compliance
1. Facility Design Features	The ISFSI or MRS must be designed for decommissioning. Provisions must be made to facilitate decontamination of structures and equipment, minimize the quantity of radioactive wastes and contaminated equipment, and facilitate the removal of radioactive wastes and contaminated materials at the time the ISFSI or MRS is permanently decommissioned. [10 CFR 72.130.]	The design of the ISFSI facility is site-specific, and thus not applicable to a DCSS. Decommissioning considerations are discussed in Section 2.4.
2. Cask Design Features	The cask must be designed to facilitate decontamination to the extent practicable. [10 CFR 72.236(i).]	The decontamination features of the system are discussed in Section 2.4.
3. Financial / Records	The requirements for financial assurance and record keeping associated with decommissioning are found in 10 CFR 72.30. 10 CFR 72.30 Financial Assurance and Recordkeeping for Decommissioning	Financial assurance and record keeping issues are site-specific, and thus not applicable to a DCSS.
4. License Termination	The requirements for terminating an ISFSI license and decommissioning ISFSI sites and buildings are found in 10 CFR 72.54, including the requirements for submitting the final decommissioning plan.	ISFSI license termination is a site-specific issue, and thus not applicable to a DCSS.

Decommissioning	
Acceptance Criteria	Description of Compliance
1. Decontamination of buildings and equipment, as specified in RG 1.86.	The decontamination features of the system are discussed in Section 2.4.
2. Classification and disposal of wastes, as contained in 10 CFR 61.55.	Not applicable.

1.6 Identification of Agents and Contractors

The prime contractor for the Universal Storage System design is NAC. All design and specification activities are performed by NAC. Fabrication of the steel components is by qualified vendors. Assembly of the Vertical Concrete Cask is performed by a qualified concrete contractor. All fabrication activities are performed in accordance with quality assurance programs meeting the requirements of 10 CFR 71 and 10 CFR 72.

NAC is a private corporation founded in 1968, whose primary focus is the tracking, inspection, handling, storage, and transportation of spent nuclear fuel. NAC is recognized in the industry as expert in all aspects of the design, licensing, and operation of spent fuel handling, inspection, storage, and transport equipment, as well as in the management of spent fuel inventories.

NAC is the leading United States company in the transport of spent nuclear fuel, owning and operating the largest fleet of commercial spent fuel transport casks in the United States. This fleet includes the following casks:

- 5 NLI-1/2 (truck) – 1 PWR/2 BWR – Approved for the transport of LWR and metallic fuel and for high level waste.
- 8 NAC-LWT (truck) – 1 PWR/2 BWR – Approved for the transport of LWR fuel, metallic fuel, research reactor fuel and high level waste.
- 2 NLI-10/24 (Rail) – 10 PWR/24 BWR – Approved for the transport of LWR fuel

These casks are approved by the U.S. NRC under 10 CFR 71 and have successfully and safely completed more than 3,500 shipments of spent fuel and high-level waste for more than 60 nuclear facilities.

NAC has designed, analyzed, and obtained NRC approval for the following dry storage casks:

- NAC-I26 S/T – Approved on Part 72 Subpart K with Certificate of Compliance for storage of 26 PWR fuel assemblies (Docket 72-1002)
- NAC-I28 S/T – Approved as suitable reference for use in a site specific license application for the storage of 28 PWR fuel assemblies (Docket 72-1020)
- NAC-C28 S/T – Approved on Part 72 Subpart K with Certificate of Compliance for the storage of 28 consolidated PWR fuel canisters (56 assemblies) (Docket 72-1003)

Within the past 15 years, NAC has completed fabrication or has under construction the following storage and/or transportation casks:

Part 71 fabrication statistics:

- 8 NAC-LWT shipping casks
- 16 TRUPACT-II shipping casks
- 6 RH-TRU 72B shipping casks
- 2 NAC-STC shipping casks

Part 72 fabrication/construction statistics:

- 6 UMS/MPC transfer casks
- 2 NAC-I28 S/T storage casks
- 1 NAC-I26 S/T storage cask
- 173 UMS/MPC transportable storage canisters
- 179 UMS/MPC concrete storage casks

NAC has also designed the NAC-STC rail cask for the storage and transport of directly loaded spent fuel. The NAC-STC is approved for use in site specific applications (Docket 72-1013) for storage and for transport (Certificate of Compliance Number 71-9235) of directly-loaded fuel and canistered Yankee class spent fuel.

The Multi-Purpose Canister system (NAC-MPC) is approved for the long-term storage of Yankee class spent fuel (Docket 72-1025).

Finally, the Transportable Storage Canister reported in this SAR is designed to be transported in the Universal Transport Cask. The Safety Analysis Report for the Universal Transport Cask is submitted under Docket 71-9270.

1.7 References

1. Code of Federal Regulations, "Licensing Requirements for the Independent Storage of Spent Nuclear Fuel and High-Level Radioactive Waste," Part 72, Title 10, January 1996.
2. Nuclear Regulatory Commission, "Standard Review Plan for Dry Cask Storage Systems," NUREG-1536, January 1997.
3. NAC Document No. EA790-SAR-001, "Safety Analysis Report for the UMS® Universal Transport Cask," Docket No. 71-9270, April 1997.
4. Department of Energy, "Multi-Purpose Canister (MPC) Subsystem Design Procurement Specification," Document No. DBG000000-01717-6300-00001, Rev. 6, June 1996.
5. Nuclear Regulatory Commission, "Standard Format and Content for a Topical Safety Analysis Report for a Spent Fuel Dry Concrete Cask," Regulatory Guide 3.61, February 1989.
6. ANSI/ANS-57.9-1992, "Design Criteria for an Independent Spent Fuel Storage Installation (Dry Type)," American Nuclear Society, May 1992.
7. American Concrete Institute, "Building Code Requirements for Structural Concrete," (ACI 318-95) and Commentary (ACI 318R-95), October 1995.
8. ASME Boiler and Pressure Vessel Code, Division I, Section III, Subsection NB, "Class 1 Components," 1995 Edition with 1995 Addenda.
9. ASME Boiler and Pressure Vessel Code, Section V, "Nondestructive Examination," 1995 Edition with 1995 Addenda.
10. ASME Boiler and Pressure Vessel Code, Division I, Section III, Subsection NG, "Core Support Structures," 1995 Edition with 1995 Addenda.
11. Nuclear Regulatory Commission, "Control of Heavy Loads at Nuclear Power Plants," NUREG-0612, July 1980.

12. ANSI N14.6-1993, “American National Standard for Radioactive Materials – Special Lifting Devices for Shipping Containers Weighing 10,000 Pounds (4,500 kg) or More,” American National Standards Institute, Inc., June 1993.
13. Code of Federal Regulations, “Packaging and Transportation of Radioactive Materials,” Part 71, Title 10, April 1996.
14. ASME Boiler and Pressure Vessel Code, Section IX, “Qualification Standards for Welding and Brazing Procedures, Welders, Brazers, and Welding and Brazing Operators,” July 1995.
15. ASME Boiler and Pressure Vessel Code, Section VIII, “Rules for Construction of Pressure Vessels,” 1995 Edition with 1995 Addenda.
16. Recommended Practice No. SNT-TC-1A, “Personnel Qualification and Certification in Nondestructive Testing,” The American Society for Nondestructive Testing, Inc., edition as invoked by the applicable ASME Code.
17. ANSI N45.2.1, “Cleaning of Fluid Systems and Associated Components During Construction Phase of Nuclear Power Plants.”
18. ANSI N45.2.2-1978, “Packaging, Shipping, Receiving, Storage, and Handling of Items for Nuclear Power Plants.”
19. American Society for Testing and Materials, “Standard Specification for Ready-Mixed Concrete,” ASTM C 94-96, April 1996.
20. American Society for Testing and Materials, “Standard Specification for Portland Cement,” ASTM C 150-95a, March 1996.
21. American Society for Testing and Materials, “Standard Specification for Concrete Aggregates,” ASTM C 33-93, December 1993.
22. American Society for Testing and Materials, “Specification for Aggregates for Radiation-Shielding Concrete,” ASTM C 637-84.
23. American Society for Testing and Materials, “Standard Specification for Chemical Admixtures for Concrete,” ASTM C 494-92, August 1992.

24. American Society for Testing and Materials, "Specification for Fly Ash and Raw or Calcined Natural Pozzolan for Use as a Mineral Admixture in Portland Cement Concrete," ASTM C 618-87.
25. American Welding Society, "Structural Welding Code Steel," AWS D1.1-96, 1996.
26. American Society for Testing and Materials, "Standard Practice for Sampling Freshly Mixed Concrete," ASTM C 172-90, June 1990.
27. American Society for Testing and Materials, "Method of Making and Curing Concrete Test Specimens in the Field," ASTM C 31-88.
28. American Society for Testing and Materials, "Standard Test Method for Compressive Strength of Cylindrical Concrete Specimens," ASTM C 39-94, January 1995.
29. Nuclear Regulatory Commission, "Cladding Considerations for the Transport and Storage of Spent Fuel," Interim Staff Guidance-11, Revision 2.

THIS PAGE INTENTIONALLY LEFT BLANK

1.8 License Drawings

This section presents the list of License Drawings for the Universal Storage System.

1.8.1 License Drawings for the UMS® Universal Storage System

Drawing Number	Title	Revision No.	No. of Sheets
790-501	Canister/Basket Assembly Table, NAC-UMS®	3	1
790-559	Assembly, Transfer Adapter, NAC-UMS®	7	4
790-560	Assembly, Standard Transfer Cask (TFR), NAC-UMS®	16	6
790-561	Weldment, Structure, Vertical Concrete Cask (VCC), NAC-UMS®	10	4
790-562	Reinforcing Bar and Concrete Placement, Vertical Concrete Cask (VCC), NAC-UMS®	13	7
790-563	Lid, Vertical Concrete Cask (VCC), NAC-UMS®	4	1
790-564	Shield Plug, Vertical Concrete Cask (VCC), NAC-UMS®	7	3
790-565	Nameplate, Vertical Concrete Cask (VCC), NAC-UMS®	4	1
790-570	Fuel Basket Assembly, 56 Element BWR, NAC-UMS®	4	2
790-571	Bottom Weldment, Fuel Basket, 56 Element BWR, NAC-UMS®	3	1
790-572	Top Weldment, Fuel Basket, 56 Element BWR, NAC-UMS®	4	1
790-573	Support Disk and Misc. Basket Details, 56 Element BWR, NAC-UMS®	7	1
790-574	Heat Transfer Disk, Fuel Basket, 56 Element BWR, NAC-UMS®	3	1
790-575	BWR Fuel Tube, NAC-UMS®	9	2
790-581	PWR Fuel Tube, NAC-UMS®	8	2
790-582	Shell Weldment, Canister, NAC-UMS®	11	2
790-583	Assembly, Drain Tube, Canister, NAC-UMS®	7	1
790-584	Details, Canister, NAC-UMS®	17	3
790-585	Transportable Storage Canister (TSC), NAC-UMS®	15	3
790-587	Spacer Shim, Canister, NAC-UMS®	1	1
790-590	Loaded Vertical Concrete Cask (VCC), NAC-UMS®	5	2
790-591	Bottom Weldment, Fuel Basket, 24 Element PWR, NAC-UMS®	6	2

License Drawings
(Continued)

Drawing Number	Title	Revision No.	No. of Sheets
790-592	Top Weldment, Fuel Basket, 24 Element PWR, NAC-UMS®	8	1
790-593	Support Disk and Misc. Basket Details, 24 Element PWR, NAC-UMS®	7	2
790-594	Heat Transfer Disk, Fuel Basket, 24 Element PWR, NAC-UMS®	2	1
790-595	Fuel Basket Assembly, 24 Element PWR, NAC-UMS®	9	2
790-605	BWR Fuel Tube, Over-Sized Fuel, NAC-UMS®	10	2
790-613	Supplemental Shielding, VCC Inlets, NAC-UMS®	2	1
790-617	Door Stop, NAC-UMS®	2	2

1.8.2 Site Specific Spent Fuel License Drawings

Drawing Number	Title	Revision No.	No. of Sheets
412-501	Spent Fuel Can Assembly, Maine Yankee (MY), NAC-UMS®	4	2
412-502	Fuel Can Details, Maine Yankee (MY), NAC-UMS®	4	6

Figure Withheld Under 10 CFR 2.390



 NAC INTERNATIONAL	
CANISTER / BASKET ASSEMBLY TABLE NAC-UMS®	
MODEL 790	REV. 501
MADE IN U.S.A.	© 1988

Figure Withheld Under 10 CFR 2.390

 NAC INTERNATIONAL	
ASSEMBLY, TRANSFER ADAPTER, NAC-UMS®	
PROJECT 790	REVISED 559 7
DATE 1/10	BY NOTED

A

Figure Withheld Under 10 CFR 2.390

 NAC INTERNATIONAL	
ASSEMBLY, TRANSFER ADAPTER, NAC-UMS®	
790	559
DATE 1/10	DATE NOTED 12/2/10

A

Figure Withheld Under 10 CFR 2.390

 NAC INTERNATIONAL			
ASSEMBLY, TRANSFER ADAPTER, NAC-UMS®			
ORDER	790	QUANTITY	559
PAGE 1/3	REV. NOTED	1-3	of 4

A

Figure Withheld Under 10 CFR 2.390

 NAC INTERNATIONAL	
ASSEMBLY, TRANSFER ADAPTER, NAC-UMS®	
FORM NO. 790	REVISED 559 7
MAR 1/6	NOTES NOTED IN-4 OF 4 10/2011

A

Figure Withheld Under 10 CFR 2.390

 NAC INTERNATIONAL			
ASSEMBLY, STANDARD TRANSFER CASK (TFR) NAC-UMS®			
790	560	1/8	
1/20	NOTED	1	8

A

Figure Withheld Under 10 CFR 2.390

 NAC INTERNATIONAL	
ASSEMBLY, STANDARD TRANSFER CASK (TFR) NAC-UMS [®]	
MAX 790	MIN 560
DATE 1/15	REV. NOTED 1-2-81

A

Figure Withheld Under 10 CFR 2.390

 NAC INTERNATIONAL	
ASSEMBLY, STANDARD TRANSFER CASK (TFR) NAC-UMS [®]	
Model 790	Capacity 560 L
Std 1/15	REV. NOTED 03 06

A

Figure Withheld Under 10 CFR 2.390

 NAC INTERNATIONAL	
ASSEMBLY, STANDARD TRANSFER CASK (TFR) NAC-UMS [®]	
790	560
1/70	NOTED

1

Figure Withheld Under 10 CFR 2.390

 NAC INTERNATIONAL	
ASSEMBLY, STANDARD TRANSFER CASK (TFR) NAC-UMS®	
790	560
1/10	NOTED

A

Figure Withheld Under 10 CFR 2.390

 NAC INTERNATIONAL			
ASSEMBLY, STANDARD TRANSFER CASK (TFR) NAC-UMS®			
790	560		
1/10	NOTED	1	1

A

Figure Withheld Under 10 CFR 2.390



 NAC INTERNATIONAL	
WELDMENT, STRUCTURE, VERTICAL CONCRETE CASK (VCC) NAC-UMS®	
Model 790	Serial 561 10
Rev 1/16	1

Figure Withheld Under 10 CFR 2.390

 NAC INTERNATIONAL	
WELDMENT, STRUCTURE, VERTICAL CONCRETE CASK (VCC) NAC-UMS®	
PROJECT 790	REVISED 561 10
DATE 1/18	BY 2 OF 6

A

Figure Withheld Under 10 CFR 2.390

 NAC INTERNATIONAL	
WELDMENT, STRUCTURE, VERTICAL CONCRETE CASK (VCC) NAC-UMS®	
PROJECT 790	REVISED 561
SCALE 1/16	NO. 3 of 4

1 1

Figure Withheld Under 10 CFR 2.390

 NAC INTERNATIONAL	
WELDMENT, STRUCTURE, VERTICAL CONCRETE CASK (VCC) NAC-UMS®	
790	561
1/18	1/18

Figure Withheld Under 10 CFR 2.390

 NAC INTERNATIONAL	
REINFORCING BAR AND CONCRETE PLACEMENT, VERTICAL CONCRETE CASK (VCC) NAC-UMS®	
790	562
1/1	1 of 2

Figure Withheld Under 10 CFR 2.390



 NAC INTERNATIONAL			
REINFORCING BAR AND CONCRETE PLACEMENT, VERTICAL CONCRETE CASK (VCC) NAC-UMS®			
MODEL#	790	REV#	562 13
DATE 1/20	DATE	REV 2 2	REV

Figure Withheld Under 10 CFR 2.390

 NAC INTERNATIONAL	
REINFORCING BAR AND CONCRETE PLACEMENT, VERTICAL CONCRETE CASK (VCC) NAC-UMS®	
model 790	part no 562 13
serial 1/18	serial 1-3 of 7

1 1

Figure Withheld Under 10 CFR 2.390

 NAC INTERNATIONAL			
REINFORCING BAR AND CONCRETE PLACEMENT, VERTICAL CONCRETE CASK (VCC) NAC-UMS®			
790		562	13
1/12		2	

1 1

Figure Withheld Under 10 CFR 2.390

 NAC INTERNATIONAL	
REINFORCING BAR AND CONCRETE PLACEMENT, VERTICAL CONCRETE CASK (VCC) NAC-UMS®	
PROJECT 790	REVISED 562 13
SCALE 1/20	REVISED 11-5 13

Figure Withheld Under 10 CFR 2.390

 NAC INTERNATIONAL	
REINFORCING BAR AND CONCRETE PLACEMENT, VERTICAL CONCRETE CASK (VCC) NAC-UMS®	
Model	790
Part No.	562
Rev. 1/73	Rev. 8-73

Figure Withheld Under 10 CFR 2.390

 NAC INTERNATIONAL			
REINFORCING BAR AND CONCRETE PLACEMENT, VERTICAL CONCRETE CASK (VCC) A NAC-UMS®			
PROJECT	790	ISSUE	562 13
REVISION	1/3	DATE	07/07/00

Figure Withheld Under 10 CFR 2.390

 NAC INTERNATIONAL	
LID, VERTICAL CONCRETE CASK (VCC) NAC-UMS®	
MODEL 790	REVISED 563
Sheet 1/3	Sheet 24497

Figure Withheld Under 10 CFR 2.390

 NAC INTERNATIONAL	
SHIELD PLUG, VERTICAL CONCRETE CASK (VCC) NAC-UMS®	
MODEL 790	REVISED 564 7
Sheet 1/3	of 3

Figure Withheld Under 10 CFR 2.390

 NAC INTERNATIONAL	
SHIELD PLUG, VERTICAL CONCRETE CASK (VCC)	
Model 790	Serial 564
Unit 1/3	Rev 48458

Figure Withheld Under 10 CFR 2.390



 NAC INTERNATIONAL	
SHIELD PLUG, VERTICAL CONCRETE CASK (VCC)	
790	564
1/3	4849

Figure Withheld Under 10 CFR 2.390

 NAC INTERNATIONAL	
NAMEPLATE VERTICAL CONCRETE CASK (VCC) NAC-UMS®	
790	565
SEAL FULL	DATE

A

Figure Withheld Under 10 CFR 2.390



 NAC INTERNATIONAL	
FUEL BASKET ASSEMBLY, 56 ELEMENT BWR NAC-UMS®	
Part No. 790	Part No. 570
Rev. 1/78	Rev. 1 = 2

Figure Withheld Under 10 CFR 2.390

 NAC INTERNATIONAL	
FUEL BASKET ASSEMBLY, 56 ELEMENT BWR NAC-UMS®	
PROJECT 790	REVISED 570
DATE 1/8	BY

A

Figure Withheld Under 10 CFR 2.390



 NAC INTERNATIONAL	
BOTTOM WELDMENT, FUEL BASKET, 56 ELEMENT BWR NAC-UMS®	
part no. 790	part no. 571 1
sheet 1/3	of 1 of 1

Figure Withheld Under 10 CFR 2.390

 NAC INTERNATIONAL	
TOP WELDMENT, FUEL BASKET, 56 ELEMENT BWR NAC-UMS®	
Part No. 790	Part No. 572
Rev. 1/3	Rev. 1 of 1

1

Figure Withheld Under 10 CFR 2.390

 NAC INTERNATIONAL	
SUPPORT DISK AND MISC BASKET DETAILS. 56 ELEMENT BWR NAC-UMS®	
FORM NO. 790	REV. 573
DATE 1/73	1 OF 1

Figure Withheld Under 10 CFR 2.390

 NAC INTERNATIONAL	
HEAT TRANSFER DISK FUEL BASKET, S6 ELEMENT BWR NAC-UMS [®]	
790	574 3
1/3	1

Figure Withheld Under 10 CFR 2.390



 NAC INTERNATIONAL	
BWR FUEL TUBE, NAC-UMS®	
part no. 790	part no. 575
total 2/1	total 1

Figure Withheld Under 10 CFR 2.390

 NAC INTERNATIONAL	
BWR FUEL TUBE, NAC-UMS®	
Model 790	Part No. 575
Rev. 1/71	Rev. 1/71

1

A

Figure Withheld Under 10 CFR 2.390

 NAC INTERNATIONAL	
PWR FUEL TUBE, NAC-UMS®	
790	581
1	2

1

Figure Withheld Under 10 CFR 2.390

 NAC INTERNATIONAL	
PWR FUEL TUBE, NAC-UMS®	
790	581
Serial FULL	of 2

1 1

A

Figure Withheld Under 10 CFR 2.390





 NAC INTERNATIONAL	
SHELL WELDMENT CANISTER NAC-UMS®	
Weight 790	Volume 582 
Size 1/2	Dr 1 of 2 

Figure Withheld Under 10 CFR 2.390

 NAC INTERNATIONAL	
SHELL WELDMENT CANISTER NAC-UMS®	
790	582
1/0	2 2

A

Figure Withheld Under 10 CFR 2.390

 NAC INTERNATIONAL	
ASSEMBLY, DRAIN TUBE, CANISTER NAC-UMS [®]	
790	583
1 of 1	1 of 1

A

Figure Withheld Under 10 CFR 2.390

 NAC INTERNATIONAL	
DETAILS, CANISTER NAC-UMS®	
<small>FORM</small> 790	<small>REV</small> 584 17
<small>DATE 1/78</small>	<small>NO. 1 OF 3</small>

A

Figure Withheld Under 10 CFR 2.390

 NAC INTERNATIONAL	
DETAILS, CANISTER NAC-UMS®	
FORMER 790	FORMER 584 177
REV. 1/78	REV. 2 3

A

Figure Withheld Under 10 CFR 2.390

 NAC INTERNATIONAL	
DETAILS, CANISTER NAC-UMS®	
790	584 17
DATE 1/8	PP-01 3 3

A

Figure Withheld Under 10 CFR 2.390

 NAC INTERNATIONAL	
TRANSPORTABLE STORAGE CANISTER, (TSC) NAC-UMS®	
MODEL 790	WEIGHT 585 LB
SIZE 1/8	NO. 1 OF 3

A

Figure Withheld Under 10 CFR 2.390



 NAC INTERNATIONAL	
TRANSPORTABLE STORAGE CANISTER, (TSC) NAC-UMS [®]	
790	585
1	1

Figure Withheld Under 10 CFR 2.390

 NAC INTERNATIONAL	
TRANSPORTABLE STORAGE CANISTER, (TSC) NAC-UMS®	
790	585 13
1/0	3 3

A

Figure Withheld Under 10 CFR 2.390

 NAC INTERNATIONAL	
SPACER SHIM, CANISTER NAC-UMS®	
Part 790	Part 587
Rev 1/73	Rev NOICD 10-1-73

A

Figure Withheld Under 10 CFR 2.390



 NAC INTERNATIONAL	
LOADED VERTICAL CONCRETE CASK (VCC) NAC-UMS®	
PROJECT 790	REV 590
REV 1/18	REV 2

Figure Withheld Under 10 CFR 2.390

 NAC INTERNATIONAL	
LOADED VERTICAL CONCRETE CASK (VCC) NAC-UMS®	
790	590
<small>Model 1/4</small>	<small>NOTED</small>

A

Figure Withheld Under 10 CFR 2.390

 NAC INTERNATIONAL	
BOTTOM WELDMENT, FUEL BASKET, 24 ELEMENT PWR NAC-UMS®	
790	591
Sheet 1/3	Rev. 313P

Figure Withheld Under 10 CFR 2.390



 NAC INTERNATIONAL	
BOTTOM WELDMENT, FUEL BASKET, 24 ELEMENT PWR NAC-UMS®	
790	591
REV 1/5	REV 5/13

Figure Withheld Under 10 CFR 2.390

 NAC INTERNATIONAL			
TOP WELDMENT, FUEL BASKET, 24 ELEMENT PWR NAC-UMS®			
PROJECT	790	PLANT	592
Sheet 1/2	Sheet 225F	of 1 of 1	

1 1

A

Figure Withheld Under 10 CFR 2.390

 NAC INTERNATIONAL	
SUPPORT DISK AND MISC. BASKET DETAILS, 24 ELEMENT PWR NAC-UMS [®]	
790	593 7
1/5	1.0 2

A

Figure Withheld Under 10 CFR 2.390

 NAC INTERNATIONAL	
SUPPORT DISK AND MISC. BASKET DETAILS, 24 ELEMENT PWR NAC-UMS®	
790	593 7
<small>Page 1/3</small>	<small>1000</small>

A

Figure Withheld Under 10 CFR 2.390

 NAC INTERNATIONAL	
HEAT TRANSFER DISK, FUEL BASKET, 24 ELEMENT PWR NAC-UMS®	
790	594
1/3	1

A

Figure Withheld Under 10 CFR 2.390

 NAC INTERNATIONAL		
FUEL BASKET ASSEMBLY, 24 ELEMENT PWR NAC-UMS®		
790		595 13
1/8		2 1/2

Figure Withheld Under 10 CFR 2.390

 NAC INTERNATIONAL	
FUEL BASKET ASSEMBLY, 24 ELEMENT PWR NAC-UMS [®]	
PROJECT 790	REVISED 595
SCALE 1/8" = 1"	REV OF 1

Figure Withheld Under 10 CFR 2.390



 NAC INTERNATIONAL	
BWR FUEL TUBE, OVER-SIZED FUEL, NAC-UMS®	
QUANTITY 790	WEIGHT 605 <small>lb</small>
DATE 1/1	REV. 1

Figure Withheld Under 10 CFR 2.390

 NAC INTERNATIONAL	
BWR FUEL TUBE, OVER-SIZED FUEL, NAC-UMS®	
MODEL 790	605
REV 1/1	REV 2/2

A

Figure Withheld Under 10 CFR 2.390



 NAC INTERNATIONAL	
SUPPLEMENTAL SHIELDING, VCC INLETS, NAC-UMS[®]	
Model#	790
Standard	61.3 1/2"
Model 1/4"	1

Figure Withheld Under 10 CFR 2.390

 NAC INTERNATIONAL			
DOOR STOP NAC-UMS®			
790	617		
1/1	88	1	2

A

Figure Withheld Under 10 CFR 2.390

 NAC INTERNATIONAL	
DOOR STOP NAC-UMS®	
790	617 1/2
1	1

A

Figure Withheld Under 10 CFR 2.390

 NAC INTERNATIONAL	
SPENT FUEL CAN ASSEMBLY MAINE YANKEE (MY) NAC-UMS®	
PROJECT 412	ISSUE 501
REVISED FULL	REV. 1338
OF 1	OF 2

1

A

Figure Withheld Under 10 CFR 2.390

 NAC INTERNATIONAL	
SPENT FUEL CAN ASSEMBLY MAINE YANKEE (MY) NAC-UMS®	
<small>PACKAGE</small> 412	<small>SPENT</small> 501
<small>MAX FULL</small>	<small>FORM 1332</small> 2 of 2

A

Figure Withheld Under 10 CFR 2.390

 NAC INTERNATIONAL	
FUEL CAN DETAILS MAINE YANKEE (MY) NAC-UMS®	
412	502
FORM FULL	FORM NOTED

1

Figure Withheld Under 10 CFR 2.390



 NAC INTERNATIONAL	
FUEL CAN DETAILS MAINE YANKEE (MY) NAC-UMS®	
Product 412	Quantity 502
Unit FULL	Other NOTED
1	1

Figure Withheld Under 10 CFR 2.390

 NAC INTERNATIONAL	
FUEL CAN DETAILS MAINE YANKEE (NY) NAC-UMS®	
PROJECT 412	ISSUE 502
REV FULL	REV NOTED

1 1

A

Figure Withheld Under 10 CFR 2.390

 NAC INTERNATIONAL	
FUEL CAN DETAILS MAINE YANKEE (MY) NAC-UMS®	
412	502
FULL	NOTED

A

Figure Withheld Under 10 CFR 2.390

 NAC INTERNATIONAL	
FUEL CAN DETAILS MAINE YANKEE (MY) NAC-UMS*	
<small>PROJECT</small> 412	<small>REVISED</small> 502
<small>DATE</small> FULL	<small>DATE</small> NOTED

A

1

