

2004
WATTS BAR NUCLEAR PLANT
EFFLUENT AND WASTE DISPOSAL ANNUAL REPORT

ATTACHMENT 3.0
Offsite Dose Calculation Manual

WATTS BAR NUCLEAR PLANT

**OFFSITE DOSE
CALCULATION MANUAL (ODCM)**

Revision 13

Prepared by: Eddie Woods
Chemistry

Date: 10/15/2004

Submitted By: George Vickery

Date: 10/18/2004

Approved By: Larry Bryant
PORC Chairman

Date: 10/19/2004

PORC Meeting No.: 4047

Plant Manager: Larry Bryant

Effective Date: 10/22/2004

REVISION LOG
Page 1 of 1

REVISION NUMBER	EFFECTIVE DATE	AFFECTED PAGES	DESCRIPTION OF REVISION
Rev 6	01/22/2001	2, 55, 184	Non-intent change. Changed 3411 MWt to 3459 MWt in the Rated Thermal Power definition to support DCN-D-50494-A. Clarified the wording in Appendix B regarding when a full vacuum is established.
Rev 7	03/08/2001	2, 165-168, 171,172	Intent change. In Section 9.0 changed sampling locations for milk, vegetation, and an air sampling station. Clarified when vegetation sampling is required. Eliminated Sr-89 and Sr-90 analyses on vegetation, drinking and ground water. Revised Figures 9.2 and 9.3 to reflect the changes in sampling locations.
Rev 8	09/27/01	2, 37, 38, 162, 164-168, 170-172, 187-193	Intent change. Replaced the fish sampling requirement for three specific species with one fish sample representing a commercially important species and one recreationally important species. Eliminated the collection of Asiatic clams and bottom sediment. Revised sample locations and maps to reflect the elimination of clams and bottom sediment. Removed requirement to prepare a Safety Evaluation from Appendix C to correspond to SPP-9.4 and deleted Attachment A of Appendix C.
Rev 9	04/14/03	2, 168-170, 189, 192, 193	Intent change. Corrected REMP Table 9.2 and 9.3 monitoring locations as a result from the use of Global Positioning System. Corrected monitoring location #9 on Figure 9.1. Added signoffs to Appendix B.
Rev 10	06/06/2003	2, 3, 13 - 15,165 - 170, 177, 185	Intent change. Added action L and applicability 10 to Table 1.1-2 as a result of EDC 51461-A. Revised REMP Table 9.1 and Table 9.2 to support the increased sampling frequency and requirements to obtain baseline data for operating with TPBAR. Deleted Source Note 14 and the associated requirements since it was superseded by corrective actions from PER-01-017357.
Rev 11	10/19/2003	2,8,10,13,14, 15,16,27,28, 169, 170, 171, 175,185-188	Intent Change. Added requirements specified in the license amendment to operate with TPBAR's. Corrected monitoring location #9 sector and distance on Table 9.2 to support corrective action to PER-03-013023-000. Added map location #79 to Table 9.3 and updated Figure 9.1 to reflect the addition. Updated Appendix B.
Rev 12	09/27/2004	2, 8, 10, 16, 190, 191	Intent Change. Added requirement to perform daily channel check on tritium flow rate measuring devices FIQ-90-800 and FIQ-90-801 as corrective action to PER-9513. Changed liquid radwaste effluent line UNID from 0-F-77-5042 to 0-FIT-77-5042. Replaced Curator with BSL on Appendix C.
Rev 13	10/22/2004	1, 2, 27	Intent Change. Removed the requirement to sample and analyze tritium for containment and incore instrument room purges.

TABLE OF CONTENTS
(Page 1 of 2)

TABLE OF CONTENTS	3
LIST OF TABLES/FIGURES	4
1.0 INTRODUCTION.....	5
1.0/2.0 - CONTROLS AND SURVEILLANCE REQUIREMENTS.....	6
1/2.0 APPLICABILITY	6
1/2.1 INSTRUMENTATION.....	7
1/2.1.1 RADIOACTIVE LIQUID EFFLUENT MONITORING INSTRUMENTATION.....	7
1/2.1.2 RADIOACTIVE GASEOUS EFFLUENT MONITORING INSTRUMENTATION	12
1/2.1.3 METEOROLOGICAL INSTRUMENTATION/DATA.....	18
1/2.2 RADIOACTIVE EFFLUENTS	20
1/2.2.1 LIQUID EFFLUENTS	20
1/2.2.1.1 CONCENTRATION	20
1/2.2.1.2 DOSE	24
1/2.2.1.3 LIQUID RADWASTE TREATMENT SYSTEM	25
1/2.2.2 GASEOUS EFFLUENTS.....	26
1/2.2.2.1 DOSE RATE	26
1/2.2.2.2 DOSE - NOBLE GASES	30
1/2.2.2.3 DOSE - I-131, I-133, TRITIUM, AND RADIONUCLIDES IN PARTICULATE FORM WITH HALF-LIVES GREATER THAN EIGHT DAYS	31
1/2.2.2.4 GASEOUS RADWASTE TREATMENT	32
1/2.2.3 TOTAL DOSE	33
1/2.3 RADIOLOGICAL ENVIRONMENTAL MONITORING	34
1/2.3.1 MONITORING PROGRAM	34
1/2.3.2 LAND USE CENSUS	44
1/2.3.3 INTERLABORATORY COMPARISON PROGRAM	45
BASES	47
3.0 DEFINITIONS	54
4.0 - (NOT USED).....	60
5.0 ADMINISTRATIVE CONTROLS	60
6.0 - LIQUID EFFLUENTS	64
7.0 - GASEOUS EFFLUENTS	101
8.0 - TOTAL DOSE	161
9.0 - RADIOLOGICAL ENVIRONMENTAL MONITORING PROGRAM (REMP).....	162
10.0 REFERENCES.....	174
11.0 SOURCE NOTES	175
APPENDIX A - NOTATION CONVENTIONS.....	178
LIST OF ACRONYMS.....	183
LIST OF UNITS.....	184
APPENDIX B - DEVIATIONS IN THE WBN ODCM CONTROLS/SURVEILLANCE REQUIREMENTS FROM THOSE GIVEN IN NUREG-1301.....	185
APPENDIX C - WBN ODCM REVISION PROCESS.....	187

TABLE OF CONTENTS
(Page 2 of 2)
LIST OF TABLES/FIGURES

TABLES

1.1-1 - RADIOACTIVE LIQUID EFFLUENT MONITORING INSTRUMENTATION	8
2.1-1 - RADIOACTIVE LIQUID EFFLUENT MONITORING INSTRUMENTATION - SURVEILLANCE REQUIREMENTS.....	10
1.1-2 - RADIOACTIVE GASEOUS EFFLUENT MONITORING INSTRUMENTATION.....	13
2.1-2 - RADIOACTIVE GASEOUS EFFLUENT MONITORING INSTRUMENTATION - SURVEILLANCE REQUIREMENTS.....	16
1.1-3 - METEOROLOGICAL MONITORING INSTRUMENTATION.....	19
2.2-1 - RADIOACTIVE LIQUID WASTE SAMPLING AND ANALYSIS PROGRAM.....	21
2.2-2 - RADIOACTIVE GASEOUS WASTE MONITORING SAMPLING AND ANALYSIS PROGRAM.....	27
2.3-1 - MINIMUM REQUIRED RADIOLOGICAL ENVIRONMENTAL MONITORING PROGRAM.....	36
2.3-2 - REPORTING LEVELS FOR RADIOACTIVITY CONCENTRATIONS IN ENVIRONMENTAL SAMPLES...	41
2.3-3 - DETECTION CAPABILITIES FOR ENVIRONMENTAL SAMPLE ANALYSIS - LLD.....	42
3.1 - FREQUENCY NOTATION.....	57
3.2 - OPERATIONAL MODES.....	58
6.1 - RECEPTORS FOR LIQUID DOSE CALCULATIONS.....	81
6.2 - RADIONUCLIDE DECAY AND STABLE ELEMENT TRANSFER DATA.....	82
6.3 - DOSE CALCULATION FACTORS.....	85
6.4 - INGESTION DOSE FACTORS.....	87
6.5 - BIOACCUMULATION FACTORS FOR FRESHWATER FISH.....	95
6.6 - EXTERNAL DOSE FACTORS FOR STANDING ON CONTAMINATED GROUND.....	96
7.1 - WBN - OFFSITE RECEPTOR LOCATION DATA.....	135
7.2 - JOINT PERCENTAGE FREQUENCIES OF WIND DIRECTION AND WIND SPEED FOR DIFFERENT STABILITY CLASSES.....	136
7.3 - ADJUSTED DISPERSION FACTORS.....	143
7.4 - DOSE FACTORS FOR SUBMERSION IN NOBLE GASES.....	144
7.5 - SECTOR ELEMENTS CONSIDERED FOR POPULATION DOSES.....	145
7.6 - POPULATION WITHIN EACH SECTOR ELEMENT.....	146
7.7 - INHALATION DOSE FACTORS.....	147
9.1 - REMP - MONITORING, SAMPLING, AND ANALYSIS.....	164
9.2 - REMP - SAMPLING LOCATIONS.....	168
9.3 - REMP - THERMOLUMINESCENT DOSIMETRY LOCATIONS.....	169

FIGURES

3.1 - WBN SITE AREA MAP.....	59
6.1 - LIQUID EFFLUENT RELEASE POINTS.....	98
6.2 - LIQUID RADWASTE SYSTEM.....	99
6.3 - STEAM GENERATOR BLOWDOWN/CONDENSATE DEMINERALIZER.....	100
7.1 - GASEOUS EFFLUENT RELEASE/DISCHARGE POINTS.....	155
7.2 - DETAIL OF GASEOUS RELEASE/DISCHARGE POINTS.....	156
7.3 - GASEOUS RADWASTE TREATMENT SYSTEM.....	157
7.4 - PLUME DEPLETION EFFECT FOR GROUND LEVEL RELEASES.....	158
7.5 - VERTICAL STANDARD DEVIATION OF MATERIAL IN A PLUME.....	159
7.6 - RELATIVE DEPOSITION FOR GROUND LEVEL RELEASES.....	160
9.1 - REMP LOCATIONS WITHIN ONE MILE OF THE PLANT.....	170
9.2 - REMP LOCATIONS FROM ONE TO FIVE MILES FROM THE PLANT.....	171
9.3 - REMP LOCATIONS GREATER THAN FIVE MILES FROM THE PLANT.....	172

1.0 INTRODUCTION

The Watts Bar Nuclear Plant (WBN) Offsite Dose Calculation Manual (ODCM) is a supporting document of the WBN Technical Specifications (TS) required by WBN TS 5.7.2.3. The ODCM is divided into two major parts: Controls (Sections 1 through 5) and program description (Sections 6 through 9). References are given in each section as applicable and are further described in Section 10.0.

The first part of the ODCM (Sections 1 through 5) contains:

- 1) Radioactive Effluent Controls required by Section 5.7.2.7 of the WBN TS;
- 2) Radiological Environmental Monitoring Controls required by 10 CFR Part 50, Appendix I, Section IV.B;
- 3) Controls for Meteorological Monitoring Instrumentation;
- 4) Descriptions of the information that should be included in the Annual Radiological Environmental Operating and Radioactive Effluent Release Reports required by WBN Technical Specifications 5.9.2 and 5.9.3; and
- 5) Administrative Controls for the ODCM requirements.

These sections of the document have been prepared using the guidance provided in NUREG-1301 (Reference 1) and draft Nuclear Regulatory Commission Generic Letter (Reference 2). Exceptions to this guidance have been documented in Appendix B to the ODCM.

The second part of the ODCM (Sections 6 through 9) contains the methodologies and parameters used to:

- 1) Calculate offsite doses resulting from radioactive gaseous and liquid effluents;
- 2) Calculate gaseous and liquid effluent monitor Alarm/Trip setpoints; and,
- 3) Conduct the Radiological Environmental Monitoring Program (REMP).

These methodologies and parameters were developed using the guidance in NUREG-0133 (Reference 3); Regulatory Guide 1.109 (Reference 4); Regulatory Guide 1.111 (Reference 5); Regulatory Guide 1.113 (Reference 6); Regulatory Guide 1.21 (Reference 7); and Radiological Assessment Branch Technical Position on Environmental Monitoring (Reference 8). Where any methodology or parameter differs from the guidance provided in the above documents, it has been documented in the text and references given for the source of the information.

1.0/2.0 - CONTROLS AND SURVEILLANCE REQUIREMENTS

1/2.0 APPLICABILITY

CONTROLS

- 1.0.1 Controls shall be met during the MODES or other specified conditions in the Applicability, except as provided in Control 1.0.2.
- 1.0.2 Upon discovery of a failure to meet a Control, the Action(s) of the associated Conditions shall be met. If the Control is met or is no longer applicable prior to expiration of the Action(s), completion of the Action(s) is not required unless otherwise stated.

SURVEILLANCE REQUIREMENTS

- 2.0.1 Surveillance Requirements (SR) shall be met during MODES or other conditions in the Applicability for individual Controls, unless otherwise stated in the SR. Failure to meet the Control occurs when a surveillance is failed or when conditions occur between surveillances that would result in a failed surveillance if testing was performed. Failure to perform a surveillance within the specified frequency shall be failure to meet the Control except as provided in SR 2.0.3. Surveillances do not have to be performed on inoperable equipment or variables outside specified limits.
- 2.0.2 The specified frequency for each SR is met if the surveillance is performed within 1.25 times the interval specified in the frequency, as measured from the previous performance or as measured from a time a specified condition of the frequency is met.
- For frequencies specified as "once," the above interval extension does not apply.
- If an Action requires periodic performance on a "once per..." basis, the above frequency extension applies to each performance after the initial performance.
- Exceptions to this SR control section are stated in the individual SRs.
- 2.0.3 If it is discovered that a surveillance was not performed within its specified frequency, then compliance with the requirement to declare the Control not met may be delayed, from the time of discovery, up to 24 hours or up to the limit of the specified frequency, whichever is less. This delay period is permitted to allow performance of the surveillance.

If the surveillance is not performed within the delay period, the Control must immediately be declared not met, and the applicable Action(s) must be entered. The Action(s) begin immediately upon expiration of the delay period.

When the surveillance is performed within the delay period and the surveillance is not met, the Control must immediately be entered. The Action(s) begin immediately upon failure to meet the surveillance.

- 2.0.4 Entry into a MODE or other specified condition in the Applicability of a Control shall not be made unless the Control's surveillances have been met within their specified frequency. This provision shall not prevent passage through to MODES or other specified conditions in compliance with Action(s).

1/2 CONTROLS AND SURVEILLANCE REQUIREMENTS

1/2.1 INSTRUMENTATION

1/2.1.1 RADIOACTIVE LIQUID EFFLUENT MONITORING INSTRUMENTATION

CONTROLS

1.1.1 As required by WBN TS 5.7.2.7.a, the radioactive liquid effluent monitoring instrumentation channels shown in Table 1.1-1 shall be OPERABLE with their alarm/trip setpoints set to ensure that the limits of ODCM Control 1.2.1.1 are not exceeded. The alarm/trip setpoints of these channels shall be determined in accordance with the methodology and parameters in ODCM Section 6.2.

APPLICABILITY: This requirement is applicable as shown in Table 1.1-1.

ACTION:

- a. With a radioactive liquid effluent monitoring instrumentation channel alarm/trip setpoint less conservative than required by the above control, immediately suspend the release of radioactive liquid effluents monitored by the affected channel, or declare the channel inoperable, or change the setpoint so that it is acceptably conservative.
- b. With less than the minimum number of radioactive liquid effluent monitoring instrumentation channels OPERABLE, take the action shown in Table 1.1-1. Restore the inoperable instruments to OPERABLE status within 30 days and, if unsuccessful, explain in the next Annual Radioactive Effluent Release Report, pursuant to ODCM Administrative Control 5.2, why the inoperability was not corrected within 30 days.
- c. The provisions of SR 2.0.4 are not applicable. Report all deviations in the Annual Radioactive Effluent Release Report.

SURVEILLANCE REQUIREMENTS

2.1.1 Each radioactive liquid effluent monitoring instrumentation channel shall be demonstrated OPERABLE by performance of the CHANNEL CHECK, SOURCE CHECK, CHANNEL CALIBRATION, and CHANNEL OPERATIONAL TEST operations at the frequencies shown in Table 2.1-1.

Table 1.1-1 - RADIOACTIVE LIQUID EFFLUENT MONITORING INSTRUMENTATION
(Page 1 of 2)

INSTRUMENT	MINIMUM CHANNELS OPERABLE	ACTION	APPLICABILITY
1. RADIOACTIVITY MONITORS PROVIDING ALARM AND AUTOMATIC TERMINATION OF RELEASE			
a. Liquid Radwaste Effluent Line (RE-90-122)	1	A	(2)
b. Steam Generator Blowdown Effluent Line (RE-90-120A and -121)	1	B	(3)
c. Condensate Demineralizer Regenerant Effluent Line (RE-90-225)	1	A	(2)
2. RADIOACTIVITY MONITORS PROVIDING ALARM BUT NOT PROVIDING AUTOMATIC TERMINATION OF RELEASE			
a. Essential Raw Cooling Water Effluent Header (RE-90-133,-134,-140,-141)	1/Discharge Header	C	(1)
b. Turbine Building Sump Effluent Line (RE-90-212)	1	C	(1)
3. FLOW RATE MEASUREMENT DEVICES			
a. Liquid Radwaste Effluent Line (0-FIT-77-5042)	1	D	(2)
b. Steam Generator Blowdown Effluent Line (1-FIT-15-42)	1	D	(3)
c. Condensate Demineralizer Effluent Line (FI-14-456)	1	D	(2)
d. Diffuser Discharge Effluent Line (0-LPF-27-98)	1	D	(2)

Rev 12

Applicability Notation:

- (1) At all times.
- (2) During releases via this pathway.
- (3) During releases in MODES 1, 2, 3, and 4.

Table 1.1-1 RADIOACTIVE LIQUID EFFLUENT MONITORING INSTRUMENTATION
(Page 2 of 2)
TABLE NOTATION

ACTION A -With the number of channels OPERABLE less than required by the Minimum Channels OPERABLE requirement, the contents of the tank(s) may be released to the environment provided that prior to initiating the release:

- a. At least two independent samples of the tank's contents obtained by two technically qualified members of the facility staff are analyzed, and
- b. At least two technically qualified members of the facility staff independently verify the release rate calculations,
- c. At least two technically qualified members of the facility staff independently verify the discharge valve lineup;

Otherwise, suspend release of radioactive effluents via this pathway.

ACTION B - With the number of channels OPERABLE less than required by the Minimum Channels OPERABLE requirement, effluent releases via this pathway may continue provided grab samples are analyzed for principal gamma emitters in accordance with ODCM SR 2.2.1.1.1 and 2.2.1.1.2 .

- a. At least once per 12 hours when the specific activity of the secondary coolant is equal to or greater than $0.01\mu\text{Ci/g}$ DOSE EQUIVALENT I-131, or
- b. At least once per 24 hours when the specific activity of the secondary coolant is less than $0.01\mu\text{Ci/g}$ DOSE EQUIVALENT I-131.

ACTION C - With the number of channels OPERABLE less than required by the Minimum Channels OPERABLE requirement, effluent releases via this pathway may continue provided that, at least once per 12 hours, grab samples are collected and analyzed for principal gamma emitters in accordance with ODCM SR 2.2.1.1.1 and 2.2.1.1.2 .

ACTION D - With the number of channels OPERABLE less than required by the Minimum Channels OPERABLE requirement, effluent releases via this pathway may continue provided the flow rate is estimated at least once per 4 hours during actual releases. Pump curves or the change in tank level indication, if applicable, may be used to estimate flow.

Table 2.1-1 - RADIOACTIVE LIQUID EFFLUENT MONITORING INSTRUMENTATION -
SURVEILLANCE REQUIREMENTS*

(Page 1 of 2)

INSTRUMENT	CHANNEL CHECK	SOURCE CHECK	CHANNEL CALIBRATION	CHANNEL OPERATIONAL TEST
1. RADIOACTIVITY MONITORS PROVIDING ALARM AND AUTOMATIC TERMINATION OF RELEASE				
a. Liquid Radwaste Effluent Line (RE-90-122)	D	P	R(3)	3Q(1,6)
b. Steam Generator Blowdown Effluent Line (RE-90-120A and -121)	D	M	R(3)	3Q(5)
c. Condensate Demineralizer Regenerant Effluent Line (RE-90-225)	D	P/M**	R(3)	3Q(5)
2. RADIOACTIVITY MONITORS PROVIDING ALARM BUT NOT PROVIDING AUTOMATIC TERMINATION OF RELEASE				
a. Essential Raw Cooling Water Effluent Line (RE-90-133,-134,-140,-141)	D	M	R(3)	3Q(2)
b. Turbine Building Sump Effluent Line (RE-90-212)	D	M	R(3)	3Q(2)
3. FLOW RATE MEASUREMENT DEVICES				
a. Liquid Radwaste Effluent Line (0-FIT-77-5042)	D(4)	N/A	R	N/A
b. Steam Generator Blowdown Effluent Line (1-FIT-15-42)	D(4)	N/A	R	N/A
c. Condensate Demineralizer Effluent Line (FI-14-456)	D(4)	N/A	R	N/A
d. Diffuser Discharge Effluent Line (LPF-27-98)	D(4)	N/A	Y	Q

Rev 12

* See Table 3.1 (FREQUENCY NOTATION) for the surveillance frequency definitions.

** The source check on the condensate demineralizer radiation monitor will be performed monthly during periods of no release, and prior to each batch release during release periods (when secondary coolant activity determination (principal gamma emitters) is greater than 1×10^{-6} $\mu\text{Ci/g}$).

**Table 2.1-1 RADIOACTIVE LIQUID EFFLUENT MONITORING INSTRUMENTATION
SURVEILLANCE REQUIREMENTS**

(Page 2 of 2)

TABLE NOTATION

- (1) The CHANNEL OPERATIONAL TEST shall demonstrate that automatic isolation of this pathway occurs if the instrument indicates measured levels above the alarm/trip setpoint. The CHANNEL OPERATIONAL TEST also demonstrates control room annunciation occurs if any of the following conditions exist:
 1. Instrument indicates measured levels above the alarm setpoint, or
 2. Indication of downscale failure, or
 3. Instrumentation controls not set in operate mode, or
 4. Loss of sample flow.

- (2) The CHANNEL OPERATIONAL TEST shall demonstrate that control room alarm annunciation occurs if any of the following conditions exists:
 1. Instrument indicates measured levels above the alarm setpoint, or
 2. Indication of downscale failure, or
 3. Instrumentation controls not set in operate mode.

- (3) The initial CHANNEL CALIBRATION shall be performed using one or more of the reference standards certified by the National Institute of Standards and Technology (NIST) or using standards that have been obtained from suppliers that are traceable via measurement assurance activities with NIST. These standards shall permit calibrating the system over its intended range of energy and measurement range. For subsequent CHANNEL CALIBRATION, NIST traceable standards or sources that have been related to the initial calibration (transfer calibration sources) shall be used.

- (4) CHANNEL CHECK shall consist of verifying indication of flow during periods of release. CHANNEL CHECK shall be made at least once per 24 hours on days on which continuous, periodic or batch releases are made.

- (5) The CHANNEL OPERATIONAL TEST shall demonstrate that automatic isolation of this pathway occurs if the instrument indicates measured levels above the alarm/trip setpoint.

- (6) The CHANNEL OPERATIONAL TEST that demonstrates control room annunciation upon a loss of sample flow shall be performed at least once per 92 days.

1/2 CONTROLS AND SURVEILLANCE REQUIREMENTS

1/2.1 INSTRUMENTATION

1/2.1.2 RADIOACTIVE GASEOUS EFFLUENT MONITORING INSTRUMENTATION

CONTROLS

1.1.2 In accordance with WBN TS 5.7.2.7.a, the radioactive gaseous effluent monitoring instrumentation channels shown in Table 1.1-2 shall be OPERABLE with their alarm/trip setpoints set to ensure that the limits of ODCM Control 1.2.2.1 and Technical Specification 3.3.6 are not exceeded. The alarm/trip setpoints of these channels shall be determined and adjusted in accordance with the methodology and parameters in ODCM Section 7.1.

APPLICABILITY: As shown in Table 1.1-2.

ACTION:

- a. With a radioactive gaseous effluent monitoring instrumentation channel alarm/trip setpoint less conservative than required by the above Control, immediately suspend the release of radioactive gaseous effluents monitored by the affected channel, or declare the channel inoperable, or change the setpoint so it is acceptably conservative.
- b. With less than the minimum number of radioactive gaseous effluent monitoring instrumentation channels OPERABLE, take the ACTION shown in Table 1.1-2. Restore the inoperable instruments to OPERABLE status within 30 days and, if unsuccessful, explain in the next Annual Radioactive Effluent Release Report, per ODCM Administrative Control 5.2, why the inoperability was not corrected within 30 days.
- c. The provisions of SR 2.0.4 are not applicable. Report all deviations in the Annual Radioactive Effluent Release Report.

SURVEILLANCE REQUIREMENTS

2.1.2. Each radioactive gaseous effluent monitoring instrumentation channel shall be demonstrated OPERABLE by performance of the CHANNEL CHECK, SOURCE CHECK, CHANNEL CALIBRATION, and CHANNEL OPERATIONAL TEST at the frequencies shown in Table 2.1-2.

Table 1.1-2 - RADIOACTIVE GASEOUS EFFLUENT MONITORING INSTRUMENTATION
(Page 1 of 3)

INSTRUMENT	MINIMUM CHANNELS OPERABLE	APPLICABILITY	ACTION
1. WASTE GAS DISPOSAL SYSTEM			
a. Noble Gas Activity Monitor (RE-90-118)	1	(9)	A
b. Pressure Measuring Device	1	(9)(8)	J
WGDT A 0-PIS-77-115			
WGDT B 0-PIS-77-114			
WGDT C 0-PIS-77-113			
WGDT D 0-PIS-77-100			
WGDT E 0-PIS-77-101			
WGDT F 0-PIS-77-102			
WGDT G 0-PIS-77-145			
WGDT H 0-PIS-77-146			
WGDT J 0-PIS-77-147			
2. CONDENSER VACUUM EXHAUST SYSTEM			
a. Noble Gas Activity Monitors (RE-90-119)	1	(3)	C
b. Deleted in Revision 5			
c. Flow Rate Monitor (FE-2-256)	1	(3)	B
d. Iodine/Particulate Sample Line Heat Trace [SOURCE NOTE 13]	1	(3)	K
3. SHIELD BUILDING EXHAUST SYSTEM			
a. Noble Gas Low Range Activity Monitor (RE-90-400A)	1	(2)	E
b. Iodine/Particulate Sampler and Sampler Flow Rate Measuring Device (RE-90-400 - Monitor Item 028)	1	(2)(5)	D
c. Effluent Flow Rate Measuring Device (FI-90-400)	1	(2)	B, E
d. Isokinetic Flow Control Equipment [SOURCE NOTE 11]	1	(2)(6)	G
e. Iodine/Particulate Sample Line Heat Trace [SOURCE NOTE 13]	1	(2)	G
f. Tritium flowrate measuring device (FIQ-90-801)	1	(11)	M
4. AUXILIARY BUILDING VENTILATION SYSTEM AND FUEL HANDLING AREA VENTILATION SYSTEM			
a. Noble Gas Activity Monitor (RE-90-101B)	1	(1)	C
b. Iodine/Particulate Sampler and Sampler Flow Rate Measuring Device (FIS-90-101C)	1	(1)(5)(7)	D
c. Effluent Flow Rate Measuring Device (FI-90-300/1B)	1	(1)	B, L
d. Isokinetic Flow Control Equipment [SOURCE NOTE 11]	1	(10)	H
e. Tritium flowrate measuring device (FIQ-90-800)	1	(11)	M
5. SERVICE BUILDING VENTILATION SYSTEM			
a. Noble Gas Activity Monitor (RE-90-132B)	1	(1)	C
b. Effluent Flow Rate Measuring System (FI-90-320/1B)	1	(1)	B
6. CONTAINMENT PURGE AND EXHAUST SYSTEM			
a. Noble Gas Activity Monitors (RE-90-130, RE-90-131)	1	(4)	F

Table 1.1-2 - RADIOACTIVE GASEOUS EFFLUENT MONITORING INSTRUMENTATION
(Page 2 of 3)

Applicability Notation:

- (1) At all times.
- (2) At all times. Both Unit 1 and 2 Shield Building Exhaust System equipment must meet the minimum channel OPERABLE requirement, even for Unit 1 operation only. Operability of shield building noble gas activity monitor requires both flow rate and radiation inputs since the high radiation alarm is only on the effluent channel, which reads in $\mu\text{Ci/s}$.
- (3) In MODES 1 through 6 when Condenser Vacuum Exhaust System is in operation.
- (4) At all times in MODES 1, 2, 3, 4; during core alterations; during movement of irradiated fuel assemblies within containment.
- (5) Applies to charcoal and particulate filters, does not apply to detection channels.
- (6) Shield Building isokinetic flow control equipment may be considered operable if one primary sample pump 1,2-PMP-90-452A or -452B and the flow control valve 1,2-FCV-90-452 are operable. If automatic flow control, 1,2-FM-090-0400A, is unavailable, isokinetic flow control must be established manually (using 1,2-FC-90-452), based on flow rates determined during most recent flow rate measurement device calibration.
- (7) Auxiliary Building Exhaust iodine/particulate sampler may be considered operable with the isokinetic flow control equipment inoperable.
- (8) The pressure indicator for the WGDT being released must be operable for the tank to be released.
- (9) At all times during periods of release.
- (10) Isokinetic sampling on the Auxiliary Building Exhaust is required when flow rate exceeds 160,000 SCFM.
- (11) At all times during periods of release when irradiated TPBARs are in the Reactor or in the Spent Fuel Pool.

Compensatory Actions

- ACTION A -** With the number of channels OPERABLE less than required by the Minimum Channels OPERABLE requirement, the contents of the tank(s) may be released to the environment provided that prior to initiating the release:
- a. At least two independent samples of the tank's contents obtained by two technically qualified members of the facility staff are analyzed, and
 - b. At least two technically qualified members of the Facility Staff independently verify the release rate calculations, and
 - c. At least two technically qualified members of the Facility Staff independently verify the discharge valve lineup;
- Otherwise, suspend release of radioactive effluents via this pathway.
- ACTION B -** With the number of channels OPERABLE less than required by the Minimum Channels OPERABLE requirement, effluent releases via this pathway may continue provided the flow rate is estimated at least once per 4 hours during releases via this pathway.
- ACTION C -** With the number of channels OPERABLE less than required by the Minimum Channels OPERABLE requirement, effluent releases via this pathway may continue provided grab samples are taken at least once per 12 hours and these samples are analyzed for noble gases (gamma emitters) in accordance with plant procedures. Grab samples are required only during those periods when releases are being made.
- ACTION D -** With the number of channels OPERABLE less than required by the Minimum Channels OPERABLE requirement, effluent releases via the affected pathway may continue provided that within 4 hours after the channel has been declared inoperable, samples are continuously collected with auxiliary sampling equipment as required in Table 2.2-2. Continuous sampling is required only during those periods when releases are being made.

Table 1.1-2 - RADIOACTIVE GASEOUS EFFLUENT MONITORING INSTRUMENTATION
(Page 3 of 3)

Compensatory Actions (Continued)

ACTION E - Flow Rate Channel Inoperable - With an inoperable flow element on a discharge pathway where a fan is operating (Purge A, Purge B, ABGTS, or EGTS), effluent release may continue provided: (a) "Low Rng" on RE-90-400 is selected instead of "Eff"; and (b) at least once per 12 hours associated instrument malfunction is verified not annunciated; and (c) a reading from "Low Rng" on RE-90-400 is obtained at least once per 24 hours during the release.

Radiation Monitor Inoperable - With the "EFF" and "LOW RNG" channels inoperable, effluent releases may continue provided grab samples are taken at least once per 12 hours and these samples are analyzed for noble gases (gamma emitters) in accordance with plant procedures. Grab samples are required only during those periods when releases are being made.

ACTION F - With the number of channels OPERABLE less than required by the Minimum Channel OPERABLE requirement, immediately suspend PURGING of radioactive effluents via this pathway.

ACTION G - With the required equipment inoperable, immediately suspend any planned, routine releases via this pathway, ensure that continuous iodine/particulate sampling media are removed and analyzed [SOURCE NOTE 18], and ensure that no planned, routine releases are made until the equipment is OPERABLE.

ACTION H - With the required equipment inoperable, effluent releases may continue via this pathway provided the sampler's transmission factor(s) are corrected for the loss of this equipment.

ACTION J - With the number of channels OPERABLE less than required by the Minimum Channels OPERABLE requirement, effluent releases from that WGDT must be discontinued until the channel is OPERABLE.

ACTION K - With the heat trace inoperable and auxiliary sampling equipment required for iodine and particulate collection, effluent releases via the affected pathway may continue provided that steam generator activity is evaluated weekly to determine if a path exists for release of iodine or particulate activity, and any such activity being released is quantified in accordance with plant procedures.

ACTION L - With the required equipment INOPERABLE due to the flowrate being less than 100,000 scfm, manually adjust sample loop 0-LPF-90-300 flowrate to 20 scfm +/- 1 scfm within 4 hours to return the channel to operable status.

In addition, if the flow rate is less than 40,000scfm, then verify at least one Auxiliary Building or Fuel Handling exhaust fan is running.

ACTION M - With the required equipment inoperable, effluent releases may continue via the pathway provided that within 24 hours after the channel has been declared inoperable, samplers are replaced or tritium grab samples are taken once per 24 hours. Continuous sampling is required only during those periods when applicability note (11) is met.

Table 2.1-2 - RADIOACTIVE GASEOUS EFFLUENT MONITORING INSTRUMENTATION - SURVEILLANCE REQUIREMENTS*
(Page 1 of 2)

INSTRUMENT	CHANNEL CHECK	SOURCE CHECK	CHANNEL CALIBRATION	CHANNEL OPERATIONAL TEST
1. WASTE GAS DISPOSAL SYSTEM				
a. Noble Gas Activity Monitor (RE-90-118)	P	P	R(3)	3Q(1)
b. Pressure Measuring Device	P	N/A	R	N/A
WGDT A 0-PIS-77-115				
WGDT B 0-PIS-77-114				
WGDT C 0-PIS-77-113				
WGDT D 0-PIS-77-100				
WGDT E 0-PIS-77-101				
WGDT F 0-PIS-77-102				
WGDT G 0-PIS-77-145				
WGDT H 0-PIS-77-146				
WGDT J 0-PIS-77-147				
2. CONDENSER VACUUM EXHAUST SYSTEM				
a. Noble Gas Activity Monitor (RE-90-119)	D	M	R(3)	3Q(2)
b. Deleted in Revision 5				
c. Effluent Flow Rate Measuring Device (FE-2-256)	D	N/A	R	N/A
d. Deleted in Revision 5				
e. Iodine/Particulate Sample Line Heat Trace [SOURCE NOTE 13]	N/A	N/A	N/A	Q
3. SHIELD BUILDING EXHAUST SYSTEM				
a. Noble Gas Activity Monitor (RE-90-400A)	D	M	R(3)	3Q(2)
b. Iodine and Particulate Sampler (RE-90-402)	N/A	N/A	N/A	N/A
c. Effluent Flow Rate Measuring Device (FI-90-400)	D	N/A	R	Q
d. Sampler Flow Rate Measuring Device (RE-90-400 - Monitor Item 028)	D	N/A	R	Q
e. Iodine/Particulate Sample Line Heat Trace [SOURCE NOTE 13]	N/A	N/A	N/A	Q
f. Tritium Flow Rate Measuring Device (FIQ-90-801)	D	N/A	Y	N/A
4. AUXILIARY BUILDING VENTILATION AND FUEL HANDLING AREA VENTILATION SYSTEM				
a. Noble Gas Activity Monitor (RE-90-101B)	D	M	R(3)	3Q(2)
b. Iodine and Particulate Sampler (RE-90-101)	N/A	N/A	N/A	N/A
c. Effluent Flow Rate Measuring Device (FI-90-300/1B)	D	N/A	R	Q
d. Sampler Flow Rate Measuring Device (FIS-90-101C)	D	N/A	R	Q
e. Tritium Flow Rate Measuring Device (FIQ-90-800)	D	N/A	Y	N/A
5. SERVICE BUILDING VENTILATION SYSTEM				
a. Noble Gas Activity Monitor (RE-90-132)	D	M	R(3)	3Q(2)
b. Effluent Flow Rate Measuring System (FI-90-320/1B)	D	N/A	R	Q
6. CONTAINMENT PURGE AND EXHAUST SYSTEM				
Noble Gas Activity Monitors (RE-90-130, RE-90-131)	***	P	***(3)	***

Rev 12

Rev 12

* See Table 3.1 (FREQUENCY NOTATION) for the surveillance frequency definitions.

*** See WBN TS 3.3.6.1, 3.3.6.7, and 3.3.6.4 for these requirements.

**Table 2.1-2 - RADIOACTIVE GASEOUS EFFLUENT MONITORING INSTRUMENTATION
SURVEILLANCE REQUIREMENTS***

(Page 2 of 2)

TABLE NOTATION

- (1) The CHANNEL OPERATIONAL TEST shall also demonstrate that automatic isolation of this pathway and control room alarm annunciation occurs if any of the following conditions exists:
 1. Instrument indicates measured levels above the alarm/trip setpoint, or
 2. Indication of downscale failure, or
 3. Instrumentation controls not set in operate mode.

- (2) The CHANNEL OPERATIONAL TEST shall also demonstrate that control room alarm annunciation occurs if any of the following conditions exists:
 1. Instrument indicates measured levels above the alarm setpoint, or
 2. Indication of downscale failure, or
 3. Instrumentation controls not set in operate mode.

- (3) The initial CHANNEL CALIBRATION shall be performed using one or more of the reference standards certified by the National Institute of Standards and Technology (NIST) or using standards that have been obtained from suppliers that are traceable via measurement assurance activities with NIST. These standards shall permit calibrating the system over its intended range of energy and measurement range. For subsequent CHANNEL CALIBRATION, NIST traceable standards or sources that have been related to the initial calibration (transfer calibration sources) shall be used.

1/2 CONTROLS AND SURVEILLANCE REQUIREMENTS

1/2.1 INSTRUMENTATION

1/2.1.3 METEOROLOGICAL INSTRUMENTATION/DATA

CONTROLS

1.1.3 The meteorological monitoring instrumentation channels shown in Table 1.1-3 shall be OPERABLE.

APPLICABILITY: At all times.

ACTION:

With one or more required meteorological monitoring channels inoperable for more than 7 days, prepare and submit a Special Report to the NRC, pursuant to ODCM Administrative Control 5.4, within the next 10 days outlining the cause of the malfunction and the plans for restoring the channel(s) to OPERABLE status.

The provisions of SR 2.0.4 are not applicable.

SURVEILLANCE REQUIREMENTS

2.1.3 Each of the above meteorological instrumentation channels shall be demonstrated OPERABLE by the performance of the CHANNEL CHECK at least once per 24 hours and the CHANNEL CALIBRATION at least once per 184 days.

Table 1.1-3 - METEOROLOGICAL MONITORING INSTRUMENTATION

Instrument	Location	Minimum OPERABLE
1. WIND SPEED		
Channel 1	Nominal Height 10 m	2 of 3
Channel 2	Nominal Height 46 m	
Channel 3	Nominal Height 91 m	
2. WIND DIRECTION		
Channel 1	Nominal Height 10 m	2 of 3
Channel 2	Nominal Height 46 m	
Channel 3	Nominal Height 91 m	
3. AIR TEMPERATURE - DELTA T		
Channel 1	Nominal Height 10 to 46 m	1 of 3
Channel 2	Nominal Height 10 to 91 m	
Channel 3	Nominal Height 46 to 91 m	

1/2 CONTROLS AND SURVEILLANCE REQUIREMENTS

1/2.2 RADIOACTIVE EFFLUENTS

1/2.2.1 LIQUID EFFLUENTS

1/2.2.1.1 CONCENTRATION

CONTROLS

1.2.1.1 In accordance with WBN TS 5.7.2.7.b and c, the concentration of radioactive material released in liquid effluents to UNRESTRICTED AREAS (see Figure 3.1) shall be limited to 10 times the concentration values specified in Appendix B, Table 2, Column 2 to 10 CFR 20.1001-20.2401 for radionuclides other than dissolved or entrained noble gases. For dissolved or entrained noble gases, the concentration shall be limited to 2×10^{-4} $\mu\text{Ci/ml}$ total activity.

APPLICABILITY: At all times.

ACTION:

With the concentration of radioactive material released in liquid effluents exceeding the above limits, immediately restore the concentration to within the above limits.

The provisions of SR 2.0.4 are not applicable. Report all deviations in the Annual Radioactive Effluent Release Report.

SURVEILLANCE REQUIREMENTS

2.2.1.1.1 Radioactive liquid wastes shall be sampled and analyzed according to the sampling and analysis program of Table 2.2-1.

2.2.1.1.2 The results of the radioactivity analysis shall be used in accordance with the methodology and parameters in ODCM Section 6.1 to assure that the concentrations at the point of release are maintained within the limits of Control 1.2.1.1.

Table 2.2-1 - RADIOACTIVE LIQUID WASTE SAMPLING AND ANALYSIS PROGRAM*
(Page 1 of 3)

Liquid Release Type	Minimum Sampling Frequency	Minimum Analysis Frequency	Type of Activity Analysis	Lower Limit of Detection (LLD) ¹ (μCi/ml)	
Batch Release Tanks² A. Radwaste System Tanks Waste Condensate A, B, & C Cask Decontamination Chemical Drain Monitor Laundry and Hot Shower A&B B. Condensate Demineralizer System Tanks⁶ Waste Neutralization Non-Reclaimable Waste High Crud A&B	P Each Batch	P Each Batch	Principal Gamma Emitters ³	5×10^{-7}	
			I-131	1×10^{-6}	
	P One Batch/M	M	Dissolved/ Entrained Noble Gases (Gamma Emitters)	1×10^{-5}	
			H-3	1×10^{-5}	
				Gross Alpha	1×10^{-7}
				Sr-89, Sr-90	5×10^{-8}
P Each Batch	Q Lab Composite ⁴	Fe-55	1×10^{-6}		
		Continuous Releases⁵ C. Steam Generator Blowdown⁶ D. Turbine Building Sump⁶	D Each Grab Sample	D Each Grab Sample	Principal Gamma Emitters ³
I-131	1×10^{-6}				
M Grab Sample	M		Dissolved/ Entrained Noble Gases (Gamma Emitters)	1×10^{-5}	
			H-3	1×10^{-5}	
				Gross Alpha	1×10^{-7}
				Sr-89, Sr-90	5×10^{-8}
D Grab Sample	Q Lab Composite ⁴	Fe-55	1×10^{-6}		

*See Table 3.1 (FREQUENCY NOTATION) for the surveillance frequency definitions.

Table 2.2-1 - RADIOACTIVE LIQUID WASTE SAMPLING AND ANALYSIS PROGRAM

(Page 2 of 3)

TABLE NOTATION

¹ The LLD is defined for the purpose of these Controls as the smallest concentration of radioactive material in a sample that will yield a net count, above system background, that will be detected with 95% probability with only a 5% probability of falsely concluding that a blank observation represents a "real" signal. (Reference 8)

For a particular measurement system (which may include radiochemical separation):

$$LLD = \frac{4.66s_b}{E V 2.22E6 Y \exp(-\lambda\Delta t)}$$

where:

- LLD = the "a priori" lower limit of detection (microcurie per unit mass or volume).
 s_b = the standard deviation of the background counting rate or of the counting rate of a blank sample as appropriate (counts per minute).
 E = the counting efficiency (counts per disintegration).
 V = the sample size (units of mass or volume).
 2.22×10^6 = the number of disintegrations per minute per microcurie.
 Y = the fractional radiochemical yield, when applicable.
 λ = the radioactive decay constant for the particular radionuclide (s^{-1}), and
 Δt = the elapsed time between midpoint of sample collection and time of counting (s). The definition of Δt applies only to the calculation of the LLD. A more rigorous treatment of the buildup and decay during the sample collection and/or counting interval(s) may be applied to actual sample analysis if desired.

It should be recognized that the LLD is defined as an a priori (before the fact) limit representing the capability of a measurement system and not an a posteriori (after the fact) limit for a particular measurement.

Typical values of E , V , Y , and Δt should be used in the calculation.

- ² A batch release is the discharge of liquid wastes of a discrete volume. Prior to sampling for analyses, each batch shall be isolated and then thoroughly mixed by the method described in appropriate plant procedures to assure representative sampling.
- ³ The principal gamma emitters for which the LLD Control applies exclusively are the following radionuclides: Mn-54, Fe-59, Co-58, Co-60, Zn-65, Mo-99, Cs-134, Cs-137, Ce-141. Ce-144 shall also be measured, but with an LLD of 5×10^{-6} $\mu\text{Ci/ml}$. This list does not mean that only these nuclides are to be considered. Other gamma peaks which are identifiable, together with those of the above nuclides, shall also be analyzed and reported in the Annual Radioactive Effluent Release Report pursuant to ODCM Administrative Control 5.2, in the format outlined in Regulatory Guide 1.21, Appendix B, Revision 1, June 1974.
- ⁴ A laboratory composite sample is one prepared by combining representative samples from each release into one well-mixed, homogeneous sample. The volume of sample added to the composite from each release shall be proportional to the release volume. The composite sample shall be preserved according to plant procedures as appropriate.

Table 2.2-1 - RADIOACTIVE LIQUID WASTE SAMPLING AND ANALYSIS PROGRAM

(Page 3 of 3)

TABLE NOTATION

- ⁵ A continuous release is the discharge of liquid wastes of a nondiscrete volume; e.g., from a system that has an input flow during the continuous release.
- ⁶ Not applicable when most recent Secondary Coolant System activity determination (principal gamma emitters) is less than or equal to 1×10^{-6} $\mu\text{Ci/g}$ and either of the following conditions exist: (1) the discharge radiation monitor setpoint is less than or equal to 2 times background or (2) compensatory requirements associated with applicable inoperable monitors are met.

1/2 CONTROLS AND SURVEILLANCE REQUIREMENTS

1/2.2 RADIOACTIVE EFFLUENTS

1/2.2.1 LIQUID EFFLUENTS

1/2.2.1.2 DOSE

CONTROLS

1.2.1.2 In accordance with WBN TS 5.7.2.7.d and e, the dose or dose commitment to a MEMBER OF THE PUBLIC from radioactive materials in liquid effluents discharged from each unit to UNRESTRICTED AREAS (see Figure 3.1) shall be limited:

- a. During any calendar quarter to less than or equal to 1.5 mrem to the total body and to less than or equal to 5 mrem to any organ, and
- b. During any calendar year to less than or equal to 3 mrem to the total body and to less than or equal to 10 mrem to any organ.

APPLICABILITY: At all times.

ACTION:

With the calculated dose from the release of radioactive materials in liquid effluents exceeding any of the above limits, prepare and submit to the NRC within 30 days, pursuant to ODCM Administrative Control 5.4, a Special Report that identifies the cause(s) for exceeding the limit(s) and defines the corrective actions that have been taken to reduce the releases and the proposed corrective actions to be taken to assure that subsequent releases will be in compliance with the above limits. This Special Report shall also include: (1) the results of radiological analyses of drinking water sources and (2) the radiological impact on finished drinking water supplies with regard to the requirements of 40 CFR 141, Safe Drinking Water Act, (applicable only if drinking water supply is taken from the receiving water body within three miles downstream of the plant discharge).

The provisions of SR 2.0.4 are not applicable.

SURVEILLANCE REQUIREMENTS

2.2.1.2 Cumulative dose contributions from liquid effluents for the current calendar quarter and current calendar year shall be determined in accordance with the methodology and parameters in ODCM Section 6.3 at least once per 31 days.

[SOURCE NOTE 5]

1/2 CONTROLS AND SURVEILLANCE REQUIREMENTS

1/2.2 RADIOACTIVE EFFLUENTS

1/2.2.1 LIQUID EFFLUENTS

1/2.2.1.3 LIQUID RADWASTE TREATMENT SYSTEM

CONTROLS

1.2.1.3 In accordance with WBN TS 5.7.2.7.f, the Liquid Radwaste Treatment System (LRTS) shall be OPERABLE and appropriate portions of the system shall be used to reduce the radioactive materials in liquid wastes prior to their discharge when the projected doses due to the liquid effluent from each unit to UNRESTRICTED AREAS (see Figure 3.1) would exceed 0.06 mrem to the total body or 0.2 mrem to any organ in a 31-day period.

APPLICABILITY: At all times.

ACTION:

With radioactive liquid waste being discharged without treatment and in excess of the above limits and any portion of the LRTS not in operation, prepare and submit to the NRC within 30 days, pursuant to ODCM Administrative Control 5.4, a Special Report which includes the following information:

1. Explanation of why liquid waste was being discharged without treatment, identification of the inoperable equipment or subsystems, and the reason for the inoperability,
2. Action(s) taken to restore the inoperable equipment to OPERABLE status, and
3. Summary description of action(s) taken to prevent a recurrence.

The provisions of SR 2.0.4 are not applicable.

SURVEILLANCE REQUIREMENTS

2.2.1.3.1 Doses due to liquid releases from each unit to UNRESTRICTED AREAS shall be projected at least once per 31 days, in accordance with the methodology and parameters in ODCM Section 6.5 when the LRTS are not being fully utilized.
[SOURCE NOTE 9]

2.2.1.3.2 The installed LRTS shall be considered OPERABLE by meeting ODCM Controls 1.2.1.1 and 1.2.1.2.

1/2 CONTROLS AND SURVEILLANCE REQUIREMENTS

1/2.2 RADIOACTIVE EFFLUENTS

1/2.2.2 GASEOUS EFFLUENTS

1/2.2.2.1 DOSE RATE

CONTROLS

1.2.2.1 In accordance with WBN TS 5.7.2.7.g, the dose rate due to radioactive materials released in gaseous effluents from the site to areas at and beyond the UNRESTRICTED AREA BOUNDARY (see Figure 3.1) shall be limited to the following:

- a. For noble gases: Less than or equal to a dose rate of 500 mrem/y to the total body and less than or equal to a dose rate of 3000 mrem/y to the skin, and
- b. For Iodine-131, Iodine-133, tritium, and for all radionuclides in particulate form with half-lives greater than 8 days: Less than or equal to a dose rate of 1500 mrem/y to any organ.

APPLICABILITY: At all times.

ACTION:

With dose rate(s) exceeding the above limits, immediately restore the release rate to within the above limit(s).

The provisions of SR 2.0.4 are not applicable. Report all deviations in the Annual Radioactive Effluent Release Report.

SURVEILLANCE REQUIREMENTS

2.2.2.1.1 The dose rate due to noble gases in gaseous effluents shall be determined to be within the above limits in accordance with the methodology and parameters in ODCM Section 7.2.2 by obtaining representative samples and performing analyses in accordance with the sampling and analysis program specified in Table 2.2-2.
[SOURCE NOTE 7]

2.2.2.1.2 The dose rate due to Iodine-131, Iodine-133, tritium, and all radionuclides in particulate form with half-lives greater than 8 days in gaseous effluents shall be determined to be within the above limits in accordance with the methodology and parameters in ODCM Section 7.2.3 by obtaining representative samples and performing analyses in accordance with the sampling and analysis program specified in Table 2.2-2.
[SOURCE NOTE 7,1]

Table 2.2-2-RADIOACTIVE GASEOUS WASTE MONITORING SAMPLING AND ANALYSIS PROGRAM*
(Page 1 of 3)

Gaseous Release Type	Minimum Sampling Frequency	Analysis Frequency	Type of Activity Analysis	Lower Limit of Detection (LLD) ($\mu\text{Ci}/\text{ml}$) ¹
A. Waste Gas Decay Tank	P Each Tank Grab Sample	P Each Tank	Noble Gases ² (Gamma Emitters)	1×10^{-4}
			H-3 (oxide)	1×10^{-6}
B. Containment PURGE ³	P ⁸ Each PURGE Grab Sample	P Each Purge	Noble Gases ² (Gamma Emitters)	1×10^{-4}
C. Incore Instrument Room PURGE ³	Each PURGE ⁹ Grab Sample	Each Purge	Noble Gases ² (Gamma Emitters)	1×10^{-4}
D. Requirement Deleted				
E. Auxiliary Building Exh. ^{3,10} F. Condenser Vacuum Exh. ¹¹ G. Service Building Exh.	M Grab Sample	M	Noble Gases ² (Gamma Emitters)	1×10^{-4}
H. Deleted in Revision 11. I. Deleted in Revision 11. J. Deleted in Revision 11.				
K. Auxiliary Building Exh. L. Shield Building Exh. M. Condenser Vacuum Exh. ¹¹	Continuous ⁶ Tritium Sample	W	H-3 (oxide)	1×10^{-6}
	Continuous ⁶ Charcoal Sample	W ⁷	I-131 I-133	1×10^{-12} 1×10^{-10}
	Continuous ⁶ Particulate Sample	W ⁷	Principal Gamma Emitters ²	1×10^{-11}
	Continuous ⁶ Composite Particulate Sample	M	Gross Alpha	1×10^{-11}
		Q	Sr-89, Sr-90	1×10^{-11}

Rev 13

* See Table 3.1 (FREQUENCY NOTATION) for the surveillance frequency definitions.

Table 2.2-2-RADIOACTIVE GASEOUS WASTE MONITORING SAMPLING AND ANALYSIS PROGRAM

(Page 2 of 3)

TABLE NOTATION

- ¹ The LLD is defined in Note 1 of Table 2.2-1.
- ² The principal gamma emitters for which the LLD Control applies include the following radionuclides: Kr-87, Kr-88, Xe-133, Xe-133m, Xe-135, and Xe-138 in noble gas releases and Mn-54, Fe-59, I-131, Co-58, Co-60, Zn-65, Mo-99, Cs-134, Cs-137, Ce-141 and Ce-144 in Iodine and particulate releases. This list does not mean that only these nuclides are to be considered. Other gamma peaks that are identifiable, together with the above nuclides, shall also be analyzed and reported in the Annual Radioactive Effluent Release Report pursuant to ODCM Administrative Control 5.2, in the format outlined in Regulatory Guide 1.21, Appendix B, Revision 1, June 1974.
- ³ Sampling and analysis for containment purges, incore instrument room purges, and the Auxiliary Building Exhaust shall also be performed following shutdown, startup, or a thermal power change exceeding 15% of RATED THERMAL POWER within a 1 hour period unless (a) analysis shows that the DOSE EQUIVALENT I-131 concentration in the reactor coolant has not increased more than a factor of 3 and (b) the containment noble gas activity monitor (RE-90-106 or RE-90-112) or latest grab sample obtained as compensatory requirement associated with applicable inoperable monitor shows that the radioactivity has not increased by more than a factor of 3.
- ⁴ Deleted in Revision 11
- ⁵ Deleted in Revision 11
- ⁶ The ratio of the sample flow rate to the sampled stream flow rate shall be known for the time period covered by each dose or dose rate calculation made in accordance with ODCM Controls 1.2.2.1, 1.2.2.2, and 1.2.2.3.
- ⁷ Samples shall be changed at least once per 7 days and analyses shall be completed within 48 hours after changing, or after removal from sampler. Sampling shall also be performed at least once per 24 hours for at least 7 days following each shutdown, startup, or THERMAL POWER change exceeding 15% of RATED THERMAL POWER within a one hour period and analyses shall be completed within 48 hours of changing. When samples collected for 24 hours are analyzed, the corresponding LLDs may be increased by a factor of 10. This daily sampling and analysis requirement does not apply if: (1) analysis shows that the DOSE EQUIVALENT I-131 concentration in the reactor coolant has not increased by more than a factor of 3; and (2) the containment noble gas monitor aligned to lower containment (RE-90-106 or RE-90-112) or latest grab sample obtained as compensatory requirement associated with applicable inoperable monitor shows that the radioactivity has not increased by more than a factor of 3.
- ⁸ In all MODES, the compartment(s) of the containment to be purged shall be sampled for noble gas prior to PURGING.
- ⁹ The incore instrument room PURGE sample shall be obtained at the shield building monitor between 5 and 20 minutes following initiation of the incore instrument room PURGE.

Table 2.2-2-RADIOACTIVE GASEOUS WASTE MONITORING SAMPLING AND ANALYSIS PROGRAM

(Page 3 of 3)

TABLE NOTATION

- ¹⁰ Applicable in MODES 1, 2, 3, and 4, the containment will be VENTED to the containment annulus and then to the auxiliary building via containment annulus fans. The lower containment noble gas monitor (RE-90-106 or -112) response will be recorded daily when VENTING is occurring to monitor the radioactivity being discharged. The Auxiliary Building Exhaust will be re-sampled when the reading on the lower containment radiation monitor (RE-90-106 or -112) increases by 50% from the initial value. If the lower containment noble gas monitor (RE-90-106 or -112) is inoperable, noble gas grab samples may be used to perform this comparison.
- ¹¹ Not applicable when the most recent Secondary Coolant System radioactivity determination (principal gamma emitters) is less than or equal to 1×10^{-6} $\mu\text{Ci/g}$ and either of the following conditions exist:
(1) the discharge radiation monitor setpoint is less than or equal to 2 times background or
(2) compensatory requirements associated with applicable inoperable monitors are met.

1/2 CONTROLS AND SURVEILLANCE REQUIREMENTS

1/2.2 RADIOACTIVE EFFLUENTS

1/2.2.2 GASEOUS EFFLUENTS

1/2.2.2.2 DOSE - NOBLE GASES

CONTROLS

1.2.2.2 In accordance with WBN TS 5.7.2.7.h, the air dose due to noble gases released in gaseous effluents from each unit to areas at and beyond the UNRESTRICTED AREA BOUNDARY (see Figure 3.1) shall be limited to the following:

- a. During any calendar quarter: Less than or equal to 5 mrad for gamma radiation and less than or equal to 10 mrad for beta radiation, and
- b. During any calendar year: Less than or equal to 10 mrad for gamma radiation and less than or equal to 20 mrad for beta radiation.

APPLICABILITY: At all times.

ACTION:

With the calculated air dose from radioactive noble gases in gaseous effluents exceeding any of the above limits, prepare and submit to the NRC within 30 days, pursuant to ODCM Administrative Control 5.4, a Special Report that identifies the cause(s) for exceeding the limit(s) and defines the corrective actions that have been taken to reduce the releases and the proposed corrective actions to be taken to assure that subsequent releases will be in compliance with the above limits.

The provisions of SR 2.0.4 are not applicable.

SURVEILLANCE REQUIREMENTS

2.2.2.2 Cumulative dose contributions for the current calendar quarter and current calendar year for noble gases shall be determined in accordance with the methodology and parameters in ODCM Section 7.3 at least once per 31 days.
[SOURCE NOTE 5]

1/2 CONTROLS AND SURVEILLANCE REQUIREMENTS

1/2.2 RADIOACTIVE EFFLUENTS

1/2.2.2 GASEOUS EFFLUENTS

1/2.2.2.3 DOSE - I-131, I-133, TRITIUM, AND RADIONUCLIDES IN PARTICULATE FORM WITH HALF-LIVES GREATER THAN EIGHT DAYS

CONTROLS

1.2.2.3 In accordance with WBN TS 5.7.2.7.i, the dose to a MEMBER OF THE PUBLIC from I-131, I-133, tritium, and all radionuclides in particulate form with half-lives greater than 8 days in gaseous effluents released from each unit to areas at and beyond the UNRESTRICTED AREA BOUNDARY (see Figure 3.1) shall be limited to the following:

- a. During any calendar quarter: Less than or equal to 7.5 mrem to any organ and,
- b. During any calendar year: Less than or equal to 15 mrem to any organ.

APPLICABILITY: At all times.

ACTION:

With the calculated dose from the release of I-131, I-133, tritium, and all radionuclides in particulate form with half-lives greater than 8 days, in gaseous effluents exceeding any of the above limits, prepare and submit to the NRC within 30 days, pursuant to ODCM Administrative Control 5.4, a Special Report which identifies the cause(s) for exceeding the limit(s) and defines the corrective actions that have been taken to reduce the releases and the proposed corrective actions to be taken to assure that subsequent releases will be in compliance with the above limits.

The provisions of SR 2.0.4 are not applicable.

SURVEILLANCE REQUIREMENTS

2.2.2.3 Cumulative dose contributions for the current calendar quarter and current calendar year for I-131, I-133, tritium, and all radionuclides in particulate form with half-lives greater than 8 days shall be determined in accordance with the methodology and parameters in ODCM Section 7.4 at least once per 31 days.
[SOURCE NOTE 5]

1/2 CONTROLS AND SURVEILLANCE REQUIREMENTS

1/2.2 RADIOACTIVE EFFLUENTS

1/2.2.2 GASEOUS EFFLUENTS

1/2.2.2.4 GASEOUS RADWASTE TREATMENT

CONTROLS

1.2.2.4 In accordance with WBN TS 5.7.2.7.f, the VENTILATION EXHAUST TREATMENT SYSTEM and the WASTE GAS HOLDUP SYSTEM shall be OPERABLE and appropriate portions of these systems shall be used to reduce releases of radioactivity when the projected doses in 31 days due to gaseous effluent releases from each unit to areas at and beyond the UNRESTRICTED AREA BOUNDARY (See Figure 3.1) would exceed:

- a. 0.2 mrad to air from gamma radiation, or
- b. 0.4 mrad to air from beta radiation, or
- c. 0.3 mrem to any organ of a MEMBER OF THE PUBLIC.

APPLICABILITY: At all times.

ACTION:

With the radioactive gaseous waste being discharged without treatment and in excess of the above limits, prepare and submit to the NRC within 30 days, pursuant to ODCM Administrative Control 5.4, a Special Report that includes the following information:

1. Identification of the inoperable equipment or subsystems and the reason for inoperability.
2. Action(s) taken to restore the inoperable equipment to OPERABLE status, and
3. Summary description of action(s) taken to prevent a recurrence.

The provisions of SR 2.0.4 are not applicable.

SURVEILLANCE REQUIREMENTS

2.2.2.4.1 Doses due to gaseous releases from each unit to areas at and beyond the UNRESTRICTED AREA BOUNDARY shall be projected at least once per 31 days, in accordance with the methodology and parameters in ODCM Section 7.5 when the VENTILATION EXHAUST TREATMENT SYSTEMS and WASTE GAS HOLDUP SYSTEMS are not being fully utilized. [SOURCE NOTE 9]

2.2.2.4.2 The installed VENTILATION EXHAUST TREATMENT SYSTEMS and WASTE GAS HOLDUP SYSTEM shall be considered OPERABLE by meeting the requirements in ODCM Controls 1.2.2.1, 1.2.2.2, and 1.2.2.3.

1/2 CONTROLS AND SURVEILLANCE REQUIREMENTS

1/2.2 RADIOACTIVE EFFLUENTS

1/2.2.3 TOTAL DOSE

CONTROLS

1.2.3 In accordance with WBN TS 5.7.2.7.j, the annual (calendar year) dose or dose commitment to any MEMBER OF THE PUBLIC, due to releases of radioactivity and to direct radiation from uranium fuel cycle sources, shall be limited to less than or equal to 25 mrem to the total body or any organ, except the thyroid, which shall be limited to less than or equal to 75 mrem.

APPLICABILITY: At all times.

ACTION:

a. With the calculated doses from the release of radioactive materials in liquid or gaseous effluents exceeding twice the limits of ODCM Control 1.2.1.2, 1.2.2.2, or 1.2.2.3, calculations shall be made in accordance with ODCM Section 8.1 including direct radiation contributions from the reactor units and from outside storage tanks to determine whether the above limits have been exceeded. If such is the case, prepare and submit to the NRC within 30 days, pursuant to ODCM Administrative Control 5.4, a Special Report that defines the corrective action to be taken to reduce subsequent releases to prevent recurrence of exceeding the above limits and includes the schedule for achieving conformance with the above limits. This Special Report, as defined in 10 CFR 20.2203(a)(4), shall include an analysis that estimates the radiation exposure (dose) to a MEMBER OF THE PUBLIC from uranium fuel cycle sources, including all effluent pathways and direct radiation, for the calendar year that includes the release(s) covered by this report. It shall also describe levels of radiation and concentrations of radioactive materials involved, and the cause of the exposure levels or concentrations. If the estimated dose(s) exceeds the above limits, and if the release condition resulting in violation of 40 CFR 190 has not already been corrected, the Special Report shall include a request for a variance in accordance with the provisions of 40 CFR 190. Submittal of the report is considered a timely request, and a variance is granted until the staff action on the request is complete.

b. With the estimated doses exceeding the 40 CFR 190 dose limits, a separate determination must be made, in accordance with the requirements of 40 CFR 302.5, regarding the reportable quantities for radionuclide releases given in 40 CFR 302.4. Any required notifications will be made in accordance with ODCM Administrative Control 5.5.

c. The provisions of SR 2.0.4 are not applicable.

SURVEILLANCE REQUIREMENTS

2.2.3.1 Cumulative dose contributions from liquid and gaseous effluents shall be determined in accordance with ODCM Surveillance Requirements 2.2.1.2, 2.2.2.2, and 2.2.2.3 and in accordance with the methodology and parameters in ODCM Sections 6.3, 7.3, and 7.4.

2.2.3.2 Cumulative dose contributions from direct radiation from the units and from radwaste storage tanks shall be obtained from the REMP described in ODCM Section 9.1. This requirement is applicable only under conditions set forth in the action above.

1/2 CONTROLS AND SURVEILLANCE REQUIREMENTS**1/2.3 RADIOLOGICAL ENVIRONMENTAL MONITORING****1/2.3.1 MONITORING PROGRAM****CONTROLS**

1.3.1 As required by 10 CFR Part 50, Appendix I, Section IV.B, the Radiological Environmental Monitoring Program (REMP) shall be conducted as specified in Table 2.3-1.

APPLICABILITY: At all times.

ACTION:

- a. With the REMP not being conducted as specified in Table 2.3-1, prepare and submit to the NRC, in the Annual Radiological Environmental Operating Report described in ODCM Administrative Control 5.1, a description of the reasons for not conducting the program as required and the plan for preventing a recurrence.
- b. With the level of radioactivity as a result of plant effluents in an environmental sampling medium at a specified location exceeding the reporting levels of Table 2.3-2, when averaged over any calendar quarter, prepare and submit to the NRC within 30 days from the end of the affected quarter, pursuant to ODCM Administrative Control 5.4, a Special Report that identifies the cause(s) for exceeding the limit(s) and defines the corrective actions to be taken to reduce radioactive effluents so that the potential annual dose* to a MEMBER OF THE PUBLIC is less than the calendar year limits of ODCM Controls 1.2.1.2, 1.2.2.2 and 1.2.2.3. When more than one of the radionuclides in Table 2.3-2 are detected in the sampling medium, this report shall be submitted if:

$$\frac{\text{concentration}(i)}{\text{limit level } (i)} + \frac{\text{concentration}(i+1)}{\text{limit level } (i+1)} + \dots \geq 1$$

When radionuclides other than those in Table 2.3-2 are detected and are the result of plant effluents, this report shall be submitted if the potential annual dose* to a MEMBER OF THE PUBLIC from all radionuclides is equal to or greater than the calendar year limits of ODCM Controls 1.2.1.2, 1.2.2.2, and 1.2.2.3. This report is not required if the measured level of radioactivity was not the result of plant effluents; however, in such an event, the condition shall be reported and described in the Annual Radiological Environmental Operating Report described in ODCM Administrative Control 5.1.

- * The methodology and parameters used to determine the potential annual dose to a MEMBER OF THE PUBLIC shall be indicated in this report.

1/2 CONTROLS AND SURVEILLANCE REQUIREMENTS

1/2.3 RADIOLOGICAL ENVIRONMENTAL MONITORING

1/2.3.1 MONITORING PROGRAM

ACTION (CONTINUED):

- c. With milk or fresh leafy vegetation samples unavailable from one or more of the sample locations required by Table 2.3-1, identify specific locations for obtaining replacement samples and add them within 30 days to the REMP described in ODCM Section 9.0 (excluding short term or temporary unavailability). The specified locations from which samples were unavailable may then be deleted from the monitoring program.

Pursuant to ODCM Administrative Controls 5.2 and 5.3, submit in the next Effluent Release Report documentation for a change in the ODCM, with supporting information identifying the cause of the unavailability of samples and justifying the selection of the new location(s) for obtaining samples.

The provisions of SR 2.0.4 are not applicable.

SURVEILLANCE REQUIREMENTS

- 2.3.1 The radiological environmental monitoring samples shall be collected pursuant to Table 2.3-1 from the specific locations given in the tables and figures in ODCM Section 9.0 and shall be analyzed pursuant to the requirements of Table 2.3-1 and the detection capabilities required by Table 2.3-3. [SOURCE NOTE 6]

Table 2.3-1 - MINIMUM REQUIRED RADIOLOGICAL ENVIRONMENTAL MONITORING PROGRAM
(Page 1 of 5)

Exposure Pathway and/or Sample	Number of Samples and Sample Locations ¹	Sampling and Collection Frequency	Type and Frequency of Analyses
1. DIRECT RADIATION²			
	<p>Forty routine monitoring stations either with two or more dosimeters or with one instrument for measuring and recording dose rate continuously, placed as follows:</p> <p>An inner ring of stations, one in each meteorological sector in the general area of the UNRESTRICTED AREA BOUNDARY; and An outer ring of stations, one in each meteorological sector in the 6- to 8-km range from the site; and</p> <p>The balance of the stations to be placed in special interest areas such as population centers, nearby residences, schools, and in one or two areas to serve as control stations.</p>	Quarterly	Gamma dose quarterly
2. AIRBORNE			
Radioiodine and Particulates	<p>Samples from five locations:</p> <p>Three samples from close to the three unrestricted area boundary locations in different sectors of the highest calculated annual average ground-level D/Q;</p> <p>One sample from the vicinity of a community having the highest calculated annual average ground level D/Q; and</p> <p>One sample from a control location, as for example 15-30 km distant and in the least prevalent wind direction³</p>	Continuous sampler operation with sample collection weekly, or more frequently if required by dust loading.	<p>Radioiodine canister: I-131 analysis weekly</p> <p>Particulate sampler: Gross beta radioactivity analysis following filter change⁴ and gamma isotopic analysis⁵ of composite (by location quarterly)</p>

Table 2.3-1 - MINIMUM REQUIRED RADIOLOGICAL ENVIRONMENTAL MONITORING PROGRAM
(Page 2 of 5)

Exposure Pathway and/or Sample	Number of Samples and Sample Locations ¹	Sampling and Collection Frequency	Type and Frequency of Analyses
3. WATERBORNE			
Surface ⁶	One sample upstream. One sample downstream.	Composite sample over a 1-month period. ⁷	Gamma isotopic analysis ⁵ monthly; composite for tritium analysis quarterly.
Ground	Samples from one or two sources only if likely to be affected ⁸	At least once per 92 days	Gamma isotopic ⁵ and tritium analysis quarterly.
Drinking	One sample of each of one to three of the nearest water supplies that could be affected by the discharge ⁹	Composite sample over a one month period. ⁷	Gross beta and gamma isotopic analyses ⁵ monthly. Composite for tritium analysis quarterly.
Shoreline Sediment	One Sample from downstream area with existing or potential recreational value	Semiannually	Gamma isotopic ⁵ analysis semiannually
Holding Pond Sediment	Samples from at least three locations in the Yard Holding Pond	Annually	Gamma isotopic analysis ⁵ annually
4. INGESTION			
Milk	Samples from milking animals in three locations within 5 km distance having the highest dose potential. If there are none, then one additional sample from milking animals in each of one to three areas between 5 to 8 km distant where doses are calculated to be greater than 1 mrem/yr ¹⁰ One sample from milking animals at a control location 15-30 km distant and in the least prevalent wind direction. ³	Semimonthly when animals are on pasture; monthly at other times.	Gamma isotopic ⁵ and I-131 analysis semi-monthly when animals are on pasture; monthly at other times.

Table 2.3-1 MINIMUM REQUIRED RADIOLOGICAL ENVIRONMENTAL MONITORING PROGRAM
(Page 3 of 5)

Exposure Pathway and/or Sample	Number of Samples and Sample Locations ¹	Sampling and Collection Frequency	Type and Frequency of Analyses
INGESTION (continued)			
Fish	One sample of commercially important species and one sample of recreationally important species in vicinity of plant discharge area. One sample of same species in areas not influenced by plant discharge.	Sample in season, or semiannually if they are not seasonal	Gamma isotopic analysis ⁵ on edible portions.
Food Products	One sample of each principal class of food products from any area within 10 miles of the plant that is irrigated by water in which liquid plant wastes have been discharged. Samples of three different kinds of available broad leaf vegetation grown nearest each of two different offsite locations of highest predicted annual average ground-level D/Q if milk sampling is not performed as outlined in 4.a. above. One sample of each of the similar broad leaf vegetation grown 15-30 km distant in the least prevalent wind direction if milk sampling is not performed as outlined in 4.a. above. ³	At time of harvest ¹¹	Gamma isotopic analysis ⁵ on edible portion.

Table 2.3-1 - MINIMUM REQUIRED RADIOLOGICAL ENVIRONMENTAL MONITORING PROGRAM

(Page 4 of 5)

TABLE NOTATION

- ¹ Specific parameters of distance and direction sector from the centerline of one reactor, and additional description where pertinent, shall be provided for each and every sample location in Table 2.3-1 in a table(s) and figure(s) in ODCM Section 9.0. Refer to NUREG-1301, "Offsite Dose Calculation Manual Guidance: Standard Effluent Controls for Pressurized Water Reactors, Generic Letter 89-01, Supplement 1," April 1991. Deviations are permitted from the required sampling schedule if specimens are unobtainable due to hazardous conditions, seasonal unavailability, malfunction of automatic sampling equipment and other legitimate reasons. If specimens are unobtainable due to sampling equipment malfunction, every effort shall be made to complete corrective action prior to the end of the next sampling period. All deviations from the sampling schedule shall be documented in the Annual Radiological Environmental Operating Report pursuant to ODCM Administrative Control 5.1. It is recognized that, at times, it may not be possible or practicable to continue to obtain samples of the media of choice at the most desired location or time. In these instances suitable specific alternative media and locations may be chosen for the particular pathway in question and appropriate substitutions made within 30 days in the Radiological Environmental Monitoring Program given in ODCM Section 9.0. Pursuant to ODCM Administrative Controls 5.2 and 5.3, submit in the next Annual Radioactive Effluent Release Report documentation for a change in ODCM Section 9.0, including a revised figure(s) and table reflecting the new location(s) with supporting information identifying the cause of the unavailability of samples for that pathway and justifying the selection of the new location(s) for obtaining samples.
- ² One or more instruments, such as a pressurized ion chamber, for measuring and recording dose rate continuously may be used in place of, or in addition to, integrating dosimeters. For the purposes of this table, a thermoluminescent dosimeter (TLD) is considered to be one phosphor; two or more phosphors in a packet are considered as two or more dosimeters. Film badges shall not be used as dosimeters for measuring direct radiation. (The forty stations is not an absolute number. The number of direct radiation monitoring stations may be reduced according to geographical limitations, e.g., some sectors will be over water so that the number of dosimeters may be reduced accordingly. The frequency of analysis or readout for TLD systems will depend upon the characteristics of the specific system used and should be selected to obtain optimum dose information with minimal fading.)
- ³ The purpose of this sample is to obtain background information. If it is not practical to establish control locations in accordance with the distance and wind direction criteria, other sites that provide valid background data may be substituted.
- ⁴ Airborne particulate sample filters shall be analyzed for gross beta radioactivity 24 hours or more after sampling to allow for radon and thoron daughter decay. If gross beta activity in air particulate samples is greater than 10 times that of control samples, gamma isotopic analysis shall be performed on the individual samples.
- ⁵ Gamma isotopic analysis means the identification and quantification of gamma-emitting radionuclides that may be attributable to the effluents from the WBN plant.
- ⁶ The "upstream sample" shall be taken at a distance beyond significant influence of the discharge. The "downstream sample" shall be taken in an area beyond but near the mixing zone.

Table 2.3-1- MINIMUM REQUIRED RADIOLOGICAL ENVIRONMENTAL MONITORING PROGRAM

(Page 5 of 5)

TABLE NOTATION

- ⁷ A composite sample is one in which the quantity (aliquot) of liquid sampled is proportional to the quantity of flowing liquid and in which the method of sampling employed results in a specimen that is representative of the liquid flow. In this program composite sample aliquots shall be collected at time intervals that are very short (e.g., hourly) relative to the compositing period (e.g., monthly) in order to assure obtaining a representative sample. The composite sample shall be preserved according to plant procedures as appropriate.
- ⁸ Groundwater samples shall be taken when this source is tapped for drinking or irrigation purposes in areas where the hydraulic gradient or recharge properties are suitable for contamination. Groundwater flow in the area of WBN has been shown to be toward Chickamauga Reservoir (Reference 9). There are no sources tapped for drinking or irrigation purposes between the plant and the reservoir. Therefore, sampling of the medium is not required.
- ⁹ The surface water control shall be considered a control for the drinking water samples.
- ¹⁰ The dose shall be calculated for the maximum organ and age group, using the methodology and parameters in ODCM Section 7.4.
- ¹¹ If harvest occurs more than once a year, sampling shall be performed during each discrete harvest. If harvest occurs continuously, sampling shall be monthly. Attention shall be paid to including samples of tuberous and root food products.

Table 2.3-2 - REPORTING LEVELS FOR RADIOACTIVITY CONCENTRATIONS IN ENVIRONMENTAL SAMPLES

Analysis	Water (pCi/L) ³	Airborne Particulate or gases (pCi/m ³) ⁵	Fish (pCi/Kg, wet) ⁴	Milk (pCi/L) ³	Food Products (pCi/Kg, wet) ⁴
H-3	20,000 ¹	N/A	N/A	N/A	N/A
Mn-54	1,000	N/A	30,000	N/A	N/A
Fe-59	400	N/A	10,000	N/A	N/A
Co-58	1,000	N/A	30,000	N/A	N/A
Co-60	300	N/A	10,000	N/A	N/A
Zn-65	300	N/A	20,000	N/A	N/A
Zr-Nb-95	400	N/A	N/A	N/A	N/A
I-131	2 ²	0.9	N/A	3	100
Cs-134	30	10	1,000	60	1,000
Cs-137	50	20	2,000	70	2,000
Ba-La-140	200	N/A	N/A	300	N/A

¹For drinking water samples. This is 40 CFR Part 141 value. If no drinking water pathway exists, a value of 30,000 pCi/L may be used.

²For drinking water samples. If no drinking water pathway exists, value of 20 pCi/L may be used.

³ Multiply the values in this column by 10⁻⁹ to convert to units of µCi/ml.

⁴ Multiply the values in this column by 10⁻⁹ to convert to units of µCi/g(wet).

⁵ Multiply the values in this column by 10⁻¹² to convert to units of µCi/cc.

Table 2.3-3 - DETECTION CAPABILITIES FOR ENVIRONMENTAL SAMPLE ANALYSIS^{1,2}- LOWER LIMITS OF DETECTION (LLD)³
(Page 1 of 2)

Analysis	Water (pCi/L) ⁶	Airborne Particulate or Gases (pCi/m) ⁸	Fish (pCi/Kg, wet) ⁷	Milk (pCi/L) ⁶	Food Products (pCi/Kg, wet) ⁷	Sediment (pCi/Kg, dry) ⁷
gross beta	4	0.01	N/A	N/A	N/A	N/A
H-3	2000 ⁴	N/A	N/A	N/A	N/A	N/A
Mn-54	15	N/A	130	N/A	N/A	N/A
Fe-59	30	N/A	260	N/A	N/A	N/A
Co-58, 60	15	N/A	130	N/A	N/A	N/A
Zn-65	30	N/A	260	N/A	N/A	N/A
Zr-95	30	N/A	N/A	N/A	N/A	N/A
Nb-95	15	N/A	N/A	N/A	N/A	N/A
I-131	15 ⁵	0.07	N/A	1	60	N/A
Cs-134	15	0.05	130	15	60	150
Cs-137	18	0.06	150	18	80	180
Ba-140	60	N/A	N/A	60	N/A	N/A
La-140	15	N/A	N/A	15	N/A	N/A

TABLE NOTATION

- ¹ This list does not mean that only these nuclides are to be considered. Other nuclides that are identifiable, together with those of the above nuclides, shall also be analyzed and reported in the Annual Radiological Environmental Operating Report pursuant to Administrative Control 5.1.
- ² Required detection capabilities for TLDs used for environmental measurements shall be in accordance with the recommendations of Regulatory Guide 4.13.
- ³ The LLD is defined, for the purpose of these specifications, as the smallest concentration of radioactive material in a sample that will yield a net count, above system background, that will be detected with 95% probability with only a 5% probability of falsely concluding that a blank observation represents a "real" signal. (Reference 8)

For a particular measurement system (which may include radiochemical separation):

$$LLD = \frac{4.66 s_b}{E V 2.22 Y \exp(-\lambda \Delta t)}$$

Where:

LLD = the "a priori" lower limit of detection (pCi per unit mass or volume)

s_b = the standard deviation of the background counting rate or of the counting rate of a blank sample as appropriate (counts per minute)

E = the counting efficiency (counts per disintegration)

V = the sample size (units of mass or volume)

2.22 = the number of disintegrations per minute per picocurie

Table 2.3-3 - DETECTION CAPABILITIES FOR ENVIRONMENTAL SAMPLE ANALYSIS^{1,2}- LOWER LIMITS OF DETECTION (LLD)³

(Page 2 of 2)

- Y = the fractional radiochemical yield, when applicable
 λ = the radioactive decay constant for the particular radionuclide (s^{-1})
 Δt = the elapsed time between midpoint of environmental sample collection and time of counting (s).

Typical values of E, V, Y, and Δt should be used in the calculation.

It should be recognized that the LLD is defined as an a priori (before the fact) limit representing the capability of a measurement system and not an a posteriori (after the fact) limit for a particular measurement. Analysis will be performed in such a manner that the stated LLDs will be achieved under routine conditions. Occasionally background fluctuations, unavoidable small sample sizes, the presence of interfering nuclides, or other uncontrollable circumstances may render these LLDs unachievable. In such cases, the contributing factors shall be identified and described in the Annual Radiological Environmental Operating Report pursuant to ODCM Administrative Control 5.2.

- ⁴ If no drinking water pathway exists, a value of 3000 pCi/L may be used.
⁵ If no drinking water pathway exists, a value of 15 pCi/L may be used.
⁶ Multiply the values in this column by 10^{-9} to convert to units of $\mu\text{Ci/ml}$.
⁷ Multiply the values in this column by 10^{-9} to convert to units of $\mu\text{Ci/g(wet)}$.
⁸ Multiply the values in this column by 10^{-12} to convert to units of $\mu\text{Ci/cc}$.

1/2 CONTROLS AND SURVEILLANCE REQUIREMENTS

1/2.3 RADIOLOGICAL ENVIRONMENTAL MONITORING

1/2.3.2 LAND USE CENSUS

CONTROLS

1.3.2 A Land Use Census shall be conducted and shall identify within a distance of 8 km (5 miles) the location in each of the 16 meteorological sectors of the nearest milk animal, the nearest residence, and the nearest garden* of greater than 50 m² (500 ft²) producing fresh leafy vegetation.

* Broad leaf vegetation sampling of at least three different kinds of vegetation may be performed at the UNRESTRICTED AREA BOUNDARY in each of two different direction sectors with the highest predicted D/Qs in lieu of the garden census. Controls for broad leaf vegetation sampling in Table 2.3-1 Part 4.c., shall be followed, including analysis of control samples.

APPLICABILITY: At all times.

ACTION:

- a. With a Land Use Survey identifying a location(s) that yields a calculated dose or dose commitment greater than the values currently being calculated in Control 2.2.2.3, pursuant to ODCM Administrative Controls 5.1 and 5.2, identify the new location(s) in the next Annual Radioactive Effluent Release Report.
- b. With a Land Use Census identifying a location(s) that yields a calculated dose or dose commitment (via the same exposure pathway) 20% greater than at a location from which samples are currently being obtained in accordance with the requirements of ODCM Control 1.3.1, add the new location(s) within 30 days to the radiological environmental monitoring program given in ODCM Section 9.0, if samples are available. The sampling location(s), excluding the control station location, having the lowest calculated dose or dose commitment(s), via the same exposure pathway, may be deleted from this monitoring program after October 31 of the year in which this Land Use Census was conducted. Pursuant to ODCM Administrative Controls 5.2 and 5.3, submit in the next Annual Radioactive Effluent Release Report documentation for a change in the ODCM reflecting the new location(s) with the information supporting the change in sampling locations.
- c. The provisions of SR 2.0.4 are not applicable.

SURVEILLANCE REQUIREMENTS

2.3.2 The Land Use Census shall be conducted during the growing season at least once per 12 months using that information that will provide the best results, such as by a door-to-door survey, mail survey, telephone survey, aerial survey, or by consulting local agricultural authorities. The results of the Land Use Census shall be included in the Annual Radiological Environmental Operating Report pursuant to ODCM Administrative Control 5.1.

1/2 CONTROLS AND SURVEILLANCE REQUIREMENTS

1/2.3 RADIOLOGICAL ENVIRONMENTAL MONITORING

1/2.3.3 INTERLABORATORY COMPARISON PROGRAM

CONTROLS

1.3.3 Analyses shall be performed on all radioactive materials, supplied as part of an Interlaboratory Comparison Program which has been approved by the NRC, that correspond to samples required by Table 2.3-1.

APPLICABILITY: At all times.

ACTION:

With analyses not being performed as required above, report the corrective actions being taken to prevent a recurrence to the NRC in the Annual Radiological Environmental Operating Report pursuant to ODCM Administrative Control 5.1.

The provisions of SR 2.0.4 are not applicable.

SURVEILLANCE REQUIREMENTS

2.3.3 The Interlaboratory Comparison Program shall be described in ODCM Section 9.0. A summary of the results obtained as a part of the above required Interlaboratory Comparison Program shall be included in the Annual Radiological Environmental Operating Report pursuant to ODCM Administrative Control 5.1.

**BASES FOR SECTIONS 1.0 AND 2.0
CONTROLS AND SURVEILLANCE REQUIREMENTS**

NOTE

The BASES contained in succeeding pages summarize the reasons for the Controls in Sections 1.0 and 2.0, but are not part of these Controls.

BASES FOR SECTIONS 1.0 AND 2.0 - CONTROLS AND SURVEILLANCE REQUIREMENTS**1/2.1 INSTRUMENTATION****1/2.1.1 RADIOACTIVE LIQUID EFFLUENT MONITORING INSTRUMENTATION**

The radioactive liquid effluent instrumentation is provided to monitor and control, as applicable, the releases of radioactive materials in liquid effluents during actual and potential releases of liquid effluents. The alarm/trip setpoints for these instruments shall be calculated and adjusted in accordance with the methodology and parameters in ODCM Section 6.2 to ensure that the alarm/trip will occur prior to exceeding ten times the concentration limits of 10 CFR 20. The OPERABILITY and use of this instrumentation is consistent with the requirements of General Design Criteria 60, 63, and 64 of Appendix A to 10 CFR 50.

1/2.1.2 RADIOACTIVE GASEOUS EFFLUENT MONITORING INSTRUMENTATION

The radioactive gaseous effluent instrumentation is provided to monitor and control, as applicable, the releases of radioactive materials in gaseous effluents during actual and potential releases of gaseous effluents. The radiation monitor alarm/trip setpoints for each release point are based on the radioactive noble gases in gaseous effluents. It is not considered practical to apply the instantaneous alarm/trip setpoints to integrating radiation monitors sensitive to radioiodines, radioactive materials in particulate form, and radionuclides other than noble gases. The alarm/trip setpoints for these instruments shall be calculated and adjusted in accordance with the methodology and parameters in ODCM Section 7.1 to ensure that the alarm/trip will occur prior to exceeding the dose rate limits of ODCM Control 1.2.2.1. The OPERABILITY and use of this instrumentation is consistent with the requirements of General Design Criteria 60, 63, and 64 of Appendix A to 10 CFR 50.

1/2.1.3 METEOROLOGICAL INSTRUMENTATION/DATA

The OPERABILITY of the meteorological instrumentation ensures that sufficient meteorological data is available for estimating potential radiation doses to the public as a result of routine or accidental release of radioactive materials to the atmosphere. This capability is required to evaluate the need for initiating protective measures to protect the health and safety of the public and is consistent with the recommendations of Regulatory Guide 1.23, "Onsite Meteorological Programs," February 1972, ANSI/ANS-3.11-2000, "Standard for Determining Meteorological Information at Nuclear Power Sites," 2000, Regulatory Guide 1.97, "Instrumentation for Light-Water-Cooled Nuclear Power Plants to Assess Plant and Environs Conditions During and Following an Accident," May 1983, and Supplement 1 to NUREG-0737, "Requirements for Emergency Response Capability (Generic Letter 82-33)," December 1982.

The interval for the sensor calibration portion of the CHANNEL CALIBRATION is based on the length of time a sensor has been in service (i.e., non-service or "shelf" time, not to exceed six months, is not included).

NUREG-0452, "Standard Technical Specifications for Westinghouse Pressurized Water Reactors," contained meteorological monitoring instrumentation requirements. As part of the Technical Specification Improvement Program, these requirements have been split out of the Standard Technical Specifications. Therefore, the meteorological monitoring Control has been included in the ODCM.

1/2.2 RADIOACTIVE EFFLUENTS

1/2.2.1 LIQUID EFFLUENTS

1/2.2.1.1 CONCENTRATION

This Control is provided to ensure that the concentration of radioactive materials released in liquid waste effluents to UNRESTRICTED AREAS will be less than 10 times the concentration values specified in Appendix B, Table 2, Column 2 to 10 CFR 20.1001-20.2402. It provides operational flexibility for releasing liquid effluents in concentrations to follow the Section II.A and II.C design objectives of Appendix I to 10 CFR 50. This limitation provides reasonable assurance that the levels of radioactive materials in bodies of water in UNRESTRICTED AREAS will result in exposures within (1) the Section II.A design objectives of Appendix I, 10 CFR 50, to a MEMBER OF THE PUBLIC, and (2) restrictions authorized by 10 CFR 20.1301(e). The concentration limit for dissolved or entrained noble gases is based upon the assumption that Xe-135 is the controlling radioisotope and its concentration in air (submersion) was converted to an equivalent concentration in water. This specification does not affect the requirement to comply with the annual limitations of 10 CFR 20.1301(a).

This Control applies to the release of radioactive materials in liquid effluents from all reactors at the site.

The required detection capabilities for radioactive materials in liquid waste samples are tabulated in terms of the lower limits of detection (LLDs). Detailed description of the LLD, and other detection limits can be found in HASL Procedures Manual, HASL-300, Currie, L. A., "Limits for Qualitative Detection and Quantitative Determination - Application to Radiochemistry," Anal. Chem. 40, 586-93 (1968), and Hartwell, J. K., "Detection Limits for Radioanalytical Counting Techniques," Atlantic Richfield Hanford Company Report ARH-SA-215 (June 1975).

1/2.2.1.2 DOSE

This Control is provided to implement the requirements of Sections II.A, III.A, and IV.A of Appendix I, 10 CFR 50. The Control implements the guides set forth in Section II.A of Appendix I. Compliance with this Control will be considered to demonstrate compliance with the 0.1 rem limit of 10 CFR 20.1301(a)(1) per 56 FR 23374. The ACTION statements provide the required operating flexibility and at the same time implement the guides set forth in Section IV.A of Appendix I to assure that the releases of radioactive materials in liquid effluents to UNRESTRICTED AREAS will be kept "as low as reasonable achievable." Also, for fresh water sites with drinking water supplies which can be potentially affected by plant operations, there is reasonable assurance that the operation of the facility will not result in radionuclide concentrations in the finished drinking water that are in excess of the requirements of 40 CFR 141. The dose calculation methodology and parameters in the ODCM implement the requirements in Section III.A of Appendix I that conformance with the guides of Appendix I be shown by calculational procedures based on models and data, such that the actual exposure of a MEMBER OF THE PUBLIC through appropriate pathways is unlikely to be substantially underestimated. The equations specified in the ODCM section for calculating the doses due to the actual release rates of radioactive materials in liquid effluents are consistent with the methodology provided in Regulatory Guide 1.109, "Calculation of Annual Doses to Man from Routine Releases of Reactor Effluents for the Purposes of Evaluating Compliance with 10 CFR Part 50 Appendix I," Revision 1, October 1977 and Regulatory Guide 1.113, "Estimating Aquatic Dispersion of Effluents from Accidental and Routine Reactor Releases for the Purpose of Implementing Appendix I," April 1977.

This Control applies to the release of radioactive materials in liquid effluents from each unit at the site. When shared Radwaste Treatment Systems are used by more than one unit on a site, the wastes from all units are mixed for shared treatment; by such mixing, the effluent releases cannot accurately be ascribed to a specific unit. An estimate should be made of the contributions from each unit based on input conditions, e.g., flow to each of the radioactive producing units sharing the Radwaste Treatment System.

For determining conformance to controls, these allocations from shared Radwaste Treatment Systems are to be added to the releases specifically attributed to each unit to obtain the total release per site.

For those nuclides whose activities are determined from composite samples (as noted in Table 2.2-1), the concentrations for the previous composite period will be assumed as the concentration for the next period to perform the calculations in ODCM Sections 6.1 and 6.3.

1/2.2.1.3 LIQUID RADWASTE TREATMENT SYSTEM

The OPERABILITY of the LRTS ensures that this system will be available for use whenever liquid effluents require treatment prior to release to the environment. The Control that the appropriate portions of this system be used when specified provides assurance that the releases of radioactive materials in liquid effluents will be kept "as low as reasonably achievable." This requirement implements the requirements of 10 CFR 50.36a, General Design Criteria 60 of Appendix A to 10 CFR 50 and the design objective given in Section II.D of Appendix I to 10 CFR 50. The specified limits governing the use of appropriate portions of the liquid radwaste system were specified as a suitable fraction of the dose design objectives set forth in Section II.A of Appendix I, 10 CFR 50, for liquid effluents.

This Control applies to the release of radioactive materials in liquid effluents from each unit at the site. When shared LRTS are used by more than one unit on a site, the wastes from all units are mixed for shared treatment; by such mixing, the effluent releases cannot accurately be ascribed to a specific unit. An estimate should be made of the contributions from each unit based on input conditions, e.g., flow rates and radioactivity concentrations, or, if not practicable, the treated effluent releases be allocated equally to each of the radioactive producing units sharing the LRTS. For determining conformance to controls, these allocations from shared LRTS are to be added to the releases specifically attributed to each unit to obtain the total release per site.

1/2.2.2 GASEOUS EFFLUENTS

1/2.2.2.1 DOSE RATE

This Control provides reasonable assurance that radioactive material discharged in gaseous effluents will not result in the exposure of a MEMBER OF THE PUBLIC in an UNRESTRICTED AREA in excess of the design objectives of Appendix I to 10 CFR 50. This Control is provided to ensure that gaseous effluents from all units on the site will be appropriately controlled. It provides operational flexibility for releasing gaseous effluents to satisfy the Section II.A and II.C design objectives of Appendix I to 10 CFR 50. For MEMBERS OF THE PUBLIC who may at times be within the CONTROLLED or RESTRICTED AREAS, the occupancy of that MEMBER OF THE PUBLIC will usually be sufficiently low to compensate for the reduced atmospheric dispersion relative to that for the UNRESTRICTED AREA BOUNDARY. Examples of calculations for such MEMBERS OF THE PUBLIC, with the appropriate occupancy factors, shall be given in the ODCM. The specified release rate limits restrict, at all times, the corresponding gamma and beta dose rates above background to a MEMBER OF THE PUBLIC at or beyond the UNRESTRICTED AREA BOUNDARY to ≤ 500 mrem/y to the total body or to ≤ 3000 mrem/y to the skin. These limits also restrict, at all times, the corresponding thyroid dose rate above background to a child via the inhalation pathway to ≤ 1500 mrem/y. This Control does not affect the requirement to comply with the annual limitations of 10 CFR 20.1301(a).

This requirement applies to the release of radioactive material in gaseous effluents from all reactors at the site.

The required detection capabilities for radioactive materials in gaseous waste samples are tabulated in terms of the lower limits of detection (LLDs). Detailed description of the LLD, and other detection limits can be found in HASL Procedures Manual, HASL-300, Currie, L. A., "Limits for Qualitative Detection and Quantitative Determination - Application to Radiochemistry," *Anal. Chem.* 40, 586-93 (1968), and Hartwell, J. K., "Detection Limits for Radioanalytical Counting Techniques," Atlantic Richfield Hanford Company Report ARH-SA-215 (June 1975).

For those nuclides whose activities are determined from composite samples (as noted in Table 1.2-1), the concentrations for the previous composite period will be assumed as the concentration for the next period to perform the calculations in ODCM Sections 7.2.

1/2.2.2.2 DOSE - NOBLE GASES

This Control is provided to implement the requirements of Sections II.B, III.A and IV.A of Appendix I, 10 CFR 50. The requirement implements the guides set forth in Section I.B of Appendix I. Compliance with this control will be considered to demonstrate compliance with the 0.1 rem limit of 10 CFR 20.1301(a)(1) per 56 FR 23374. The ACTIONS to be taken provide the required operating flexibility and at the same time implement the guides set forth in Section IV.A of Appendix I to assure that the releases of radioactive material in gaseous effluents to UNRESTRICTED AREAS will be kept "as low as reasonably achievable." The surveillance implements the requirements in Section III.A of Appendix I that conformance with the guides of Appendix I be shown by calculational procedures based on models and data such that the actual exposure of a MEMBER OF THE PUBLIC through appropriate pathways is unlikely to be substantially underestimated. The dose calculation methodology and parameters established in ODCM Section 7.3 for calculating the doses due to the actual release rates of radioactive noble gases in gaseous effluents are consistent with the methodology provided in Regulatory Guide 1.109, "Calculation of Annual Doses to Man from Routine Releases of Reactor Effluents for the Purposes of Evaluating Compliance with 10 CFR Part 50, Appendix I," Revision 1, October 1977 and Regulatory Guide 1.111, "Methods for Estimating Atmospheric Transport and Dispersion of Gaseous Effluents in Routine Releases from Light-Water Cooled Reactors," Revision 1, July 1977. The equations provided for determining the air doses at and beyond the UNRESTRICTED AREA BOUNDARY are based upon the historical average atmospheric conditions.

This Control applies to the release of gaseous effluents from each reactor at the site. When shared Radwaste Treatment Systems are used by more than one unit on a site, the wastes from all units are mixed for shared treatment; by such mixing, the effluent releases cannot accurately be ascribed to a specific unit. An estimate should be made of the contributions from each unit based on input conditions, e.g., flow rates and radioactivity concentrations, or, if not practicable, the treated effluent releases be allocated equally to each of the radioactive producing units sharing the Radwaste Treatment System. For determining conformance to requirements, these allocations from shared Radwaste Treatment Systems are to be added to the releases specifically attributed to each unit to obtain the total release per site.

1/2.2.2.3 DOSE - IODINE-131, IODINE-133, TRITIUM, AND RADIONUCLIDES IN PARTICULATE FORM WITH HALF-LIVES GREATER THAN EIGHT DAYS

This Control is provided to implement the requirements of Sections II.C, III.A and IV.A of Appendix I, 10 CFR 50. The Control implements the guides set forth in Section II.C of Appendix I. Compliance with this control will be considered to demonstrate compliance with the 0.1 rem limit of 10 CFR 20.1301(a)(1) per 56 FR 23374. The ACTION to be taken provides the required operating flexibility and at the same time implements the guides set forth in Section IV.A of Appendix I to assure that the releases of radioactive material in gaseous effluents will be kept "as low as reasonably achievable." ODCM Section 7.4 calculational methods specified in the Surveillance Requirement implement the requirements in Section III.A of Appendix I that conformance with the guides of Appendix I be shown by calculational procedures based on models and data such that the actual exposure of a MEMBER OF THE PUBLIC through appropriately modeled pathways is unlikely to be substantially underestimated. ODCM Section 7.4 calculational methodology and parameters for calculating the doses due to the actual release rates of the subject materials are consistent with the methodologies provided in NUREG/CR-1004, "A Statistical Analysis of Selected Parameters for Predicting Food Chain Transport and Internal Dose of Radionuclides," October 1979 and Regulatory Guide 1.109, "Calculation of Annual Doses to Man from Routine Releases of Reactor Effluents for the Purposes of Evaluating Compliance with 10 CFR Part 50, Appendix I," Revision 1, October 1977 and Regulatory Guide 1.111, "Methods for Estimating Atmospheric Transport and Dispersion of Gaseous Effluents in Routine Releases from Light-Water Cooled Reactors," Revision 1, July 1977. These equations also provide for determining the actual doses based upon the historical average atmospheric conditions. The release rate controls for I-131, I-133, tritium and particulate radionuclides with half-lives greater than eight days are dependent upon the existing radionuclide pathways to man in the areas at and beyond the UNRESTRICTED AREA BOUNDARY. The pathways that were examined in the development of the calculations were: (1) individual inhalation of airborne radionuclides, (2) deposition of radionuclides onto green leafy vegetation with subsequent consumption by man, (3) deposition onto grassy areas where milk animals and beef producing animals graze with consumption of the milk and beef by man, and (4) deposition on the ground with subsequent exposure of man.

For those nuclides whose activities are determined from composite samples, the concentrations for the previous composite period will be assumed as the concentration for the next period to perform the calculations in ODCM Section 7.4.

1/2.2.2.4 GASEOUS RADWASTE TREATMENT SYSTEM

The OPERABILITY of the WASTE GAS HOLDUP SYSTEM and the VENTILATION EXHAUST TREATMENT SYSTEM ensures that the systems will be available for use whenever gaseous effluents require treatment prior to release to the environment. The Control that the appropriate portions of these systems be used when specified provides reasonable assurance that the releases of radioactive materials in gaseous effluents will be kept "as low as is reasonably achievable." This requirement implements the requirements of 10 CFR 50.36a, General Design Criteria 60 of Appendix A to 10 CFR 50, and the design objectives given in Section II.D of Appendix I to 10 CFR 50. The specified limits governing the use of appropriate portions of the systems were specified as a suitable fraction of the dose design objectives set forth in Section II.B and II.C of Appendix I, 10 CFR 50, for gaseous effluents.

This Control applies to the release of radioactive materials in gaseous effluents from each unit at the site. When shared Radwaste Treatment Systems are used by more than one unit on a site, the wastes from all units are mixed for shared treatment; by such mixing, the effluent releases cannot accurately be ascribed to a specific unit. An estimate should be made of the contributions from each unit based on input conditions, e.g., flow rates and radioactivity concentrations, or, if not practicable, the treated effluent releases be allocated equally to each of the radioactive producing units sharing the Radwaste Treatment System. For determining conformance to Controls, these allocations from shared Radwaste Treatment Systems are to be added to the releases specifically attributed to each unit to obtain the total release per site.

1/2.2.3 TOTAL DOSE

This Control is provided to meet the dose limitations of 40 CFR 190 that have been incorporated into 10 CFR 20.1301(d). The Control requires the preparation and submittal of a Special Report whenever the calculated doses due to releases of radioactivity and to radiation from uranium fuel cycle sources exceed 25 mrem to the total body or any other organ, except the thyroid, which shall be limited to less than or equal to 75 mrem. For sites containing up to 4 reactors, it is highly unlikely that the resultant dose to a MEMBER OF THE PUBLIC will exceed the dose limits of 40 CFR 190 if the individual reactors remain within twice the dose design objectives of Appendix I and if direct radiation doses from the units and from outside storage tanks are kept small. The Special Report will describe a course of action that should result in the limitation of annual dose to a MEMBER OF THE PUBLIC to within the 40 CFR 190 limits. For the purposes of the Special Report, it may be assumed that the dose commitment to the MEMBER OF THE PUBLIC from other uranium fuel cycle sources is negligible, with the exception that dose contributions from other nuclear fuel cycle facilities at the same site or within a radius of 8 km must be considered. If the dose to any MEMBER OF THE PUBLIC is estimated to exceed the requirements of 40 CFR Part 190, the Special Report with a request for a variance (provided the release conditions resulting in violation of 40 CFR 190 have not already been corrected), in accordance with the provisions of 40 CFR 190.11 and 10 CFR 20.2203(a)(4), is considered to be a timely request and fulfills the requirements of 40 CFR 190 until NRC staff action is completed. The variance only relates to the limits of 40 CFR 190, and does not apply in any way to the other requirements for dose limitation of 10 CFR 20, as addressed in ODCM Controls 1.2.1.1 and 1.2.2.1. An individual is not considered a MEMBER OF THE PUBLIC during any period in which he/she is engaged in carrying out any operation that is part of the nuclear fuel cycle. Demonstration of compliance with the limits of 40 CFR 190 or with the design objectives of Appendix I to 10 CFR 50 will be considered to demonstrate compliance with the 0.1 rem limit of 10 CFR 20.1301.

The requirements for evaluating compliance with 40 CFR 302 are added to ensure compliance with these limits. The regulation states that federally permitted releases do not have to determine compliance with the reportable quantities unless the permitted release allowance is exceeded.

1/2.3 RADIOLOGICAL ENVIRONMENTAL MONITORING

1/2.3.1 MONITORING PROGRAM

The Radiological Environmental Monitoring Program required by this Control provides representative measurements of radiation and of radioactive materials in those exposure pathways and for those radionuclides that lead to the highest potential radiation exposures of MEMBERS OF THE PUBLIC resulting from the plant operation. This monitoring program implements Section IV.B.2 of Appendix I to 10 CFR 50 and thereby supplements the Radiological Effluent Monitoring Program by verifying that the measurable concentration of radioactive materials and levels of radiation are not higher than expected on the basis of the effluent measurements and modeling of the environmental exposure pathways. Guidance for this monitoring program is provided by the Radiological Assessment Branch Technical Position on Environmental Monitoring, Revision 1, November 1979. The initially specified monitoring program will be effective for at least the first three years of commercial operation. Following this period, program changes may be initiated based on operational experience.

The required detection capabilities for environmental sample analyses are tabulated in terms of the lower limits of detection (LLDs). The LLDs required by Table 2.3-3 are considered optimum for routine environmental measurements in industrial laboratories. It should be recognized that the LLD is defined as an a priori (before the fact) limit representing the capability of a measurement system and not as a a posteriori (after the fact) limit for a particular measurement.

Detailed description of the LLD, and other detection limits can be found in HASL Procedures Manual, HASL-300, Currie, L. A., "Limits for Qualitative Detection and Quantitative Determination - Application to Radiochemistry," Anal. Chem. 40, 586-93 (1968), and Hartwell, J. K., "Detection Limits for Radioanalytical Counting Techniques," Atlantic Richfield Hanford Company Report ARH-SA-215 (June 1975).

1/2.3.2 LAND USE CENSUS

This Control is provided to ensure that changes in the use of areas at and beyond the UNRESTRICTED AREA BOUNDARY are identified and that modifications to the monitoring program are made if required by the results of that census. The best information from the door-to-door survey, mail survey, telephone survey, aerial survey, or by consulting with local agricultural authorities shall be used. This census satisfies the requirements of Section IV.B.3 of Appendix I to 10 CFR 50. Restricting the census to gardens of greater than 50 m² provides assurance that significant exposure pathways via leafy vegetables will be identified and monitored since a garden of this size is the minimum required to provide the quantity (26 kg/y) of leafy vegetables assumed in Regulatory Guide 1.109 for consumption by a child. To determine this minimum garden size, the following assumptions were used, 1) that 20% of the garden was used for growing broad leaf vegetation (i.e., similar to lettuce and cabbage), and 2) a vegetation yield of 2 kg/m².

1/2.3.3 INTERLABORATORY COMPARISON

The Control for participation in an approved Interlaboratory Comparison Program is provided to ensure that independent checks on the precision and accuracy of the measurements of radioactive material in environmental sample matrices are performed as part of the quality assurance program for environmental monitoring in order to demonstrate that the results are valid for the purposes of Section IV.B.2 of Appendix I to 10 CFR 50.

3.0 DEFINITIONS

The defined terms in this section appear in capitalized type in the text and are applicable throughout these Controls and Bases.

3.1 ACTION

ACTION shall be that part of a Control that prescribes remedial measures required under designated conditions.

3.2 CHANNEL CALIBRATION

A **CHANNEL CALIBRATION** shall be the adjustment, as necessary, of the channel such that it responds within the necessary range and accuracy to known values of input. The **CHANNEL CALIBRATION** shall encompass the entire channel including the sensor and alarm, interlock, display, and/or trip functions. Calibration of instrument channels with resistance temperature detector or thermocouple sensors shall consist of an in place cross calibration of the remaining adjustable devices in the channel. Whenever a sensing element is replaced, the next required in place cross calibration consists of comparing the other sensing elements with the recently installed sensing element. The **CHANNEL CALIBRATION** may be performed by any series of sequential, overlapping channel calibrations or total channel steps such that the entire channel is calibrated.

3.3 CHANNEL CHECK

A **CHANNEL CHECK** shall be the qualitative assessment, by observation, of channel behavior during operation. This determination shall include, where possible, comparison of the channel indication and status to other indications or status derived from independent instrument channels measuring the same parameter.

3.4 CHANNEL OPERATIONAL TEST

A **CHANNEL OPERATIONAL TEST** shall be the injection of a simulated signal or actual signal into the channel as close to the sensor as practicable to verify **OPERABILITY** of alarm, interlock, and/or trip functions. The **CHANNEL OPERATIONAL TEST** shall include adjustments, as necessary, of the required alarm, interlock, and/or trip setpoints such that the setpoints are within the required range and accuracy.

3.5 CONTROLLED AREA

A **CONTROLLED AREA**, as defined in 10 CFR 20, is the area outside the **RESTRICTED AREA** but inside the 10 CFR 20 defined **UNRESTRICTED AREA BOUNDARY**, access to which can be limited by the licensee for any reason (see Figure 3.1).

3.6 DOSE EQUIVALENT I-131

DOSE EQUIVALENT I-131 shall be that concentration of I-131 ($\mu\text{Ci/g}$) that alone would produce the same thyroid dose as the quantity and isotopic mixture of I-131, I-132, I-133, I-134, and I-135 actually present. The thyroid dose conversion factors used for this calculation shall be those listed in Table E-7 of NRC Regulatory Guide 1.109, Revision 1, October 1977.

3.0 DEFINITIONS

3.7 FREQUENCY NOTATION

The FREQUENCY NOTATION specified for the performance of Surveillance Requirements shall correspond to the intervals defined in Table 3.1.

3.8 MEMBER(S) OF THE PUBLIC

MEMBER(S) OF THE PUBLIC, as defined in 10 CFR 20, is any individual except when that individual is receiving an occupational dose.

3.9 MODE

A MODE shall correspond to any one inclusive combination of core reactivity condition, power level, and average reactor coolant temperature specified in Table 3.2 with fuel in the reactor vessel and reactor vessel head closure bolt tensioning.

3.10 OPERABLE - OPERABILITY

A system, subsystem, train, component, or device shall be OPERABLE or have OPERABILITY when it is capable of performing its specified function(s), and when all necessary attendant instrumentation, controls, normal or emergency electrical power, cooling and seal water, lubrication and other auxiliary equipment that are required for the system, subsystem, train, component, or device to perform its specified function(s) are also capable of performing their related support function(s).

3.11 PURGE - PURGING

PURGE or PURGING shall be any controlled process of discharging air or gas from a confinement to maintain temperature, pressure, humidity, concentration or other operating condition, in such a manner that replacement air or gas is required to purify the confinement.

3.12 RATED THERMAL POWER

RATED THERMAL POWER shall be a total reactor core heat transfer rate to the reactor coolant of 3459 MWt.

3.13 REPORTABLE EVENT

A REPORTABLE EVENT shall be any of those conditions specified in Section 50.73 of 10 CFR 50.

3.14 RESTRICTED AREA

The RESTRICTED AREA, as defined in 10 CFR 20, is that area, access to which is limited by the licensee for the purposes of protecting individuals against undue risks from exposure to radiation and radioactive materials. RESTRICTED AREA does not include areas used as residential quarters, but separate rooms in a residential building may be set apart as a RESTRICTED AREA (see Figure 3.1).

3.0 DEFINITIONS

3.15 SITE BOUNDARY

The site boundary is defined in 10 CFR 20 as that line beyond which the land or property is not owned, leased, or otherwise controlled by the licensee (see Figure 3.1).

3.16 SOURCE CHECK

A SOURCE CHECK shall be the qualitative assessment of channel response when the channel sensor is exposed to a radioactive source or other channel sensor internal test circuits.

3.17 UNRESTRICTED AREA/UNRESTRICTED AREA BOUNDARY

An UNRESTRICTED AREA, as defined in 10 CFR 20, shall be any area, access to which is not controlled by the licensee for the purposes of protection of individuals from exposure to radiation and radioactive materials, or any area within the SITE BOUNDARY used for residential quarters or for industrial, commercial, institutional, and/or recreational purposes.

3.18 VENTILATION EXHAUST TREATMENT SYSTEM

A VENTILATION EXHAUST TREATMENT SYSTEM is any system designed and installed to reduce gaseous radioiodine or radioactive material in particulate form in effluents by passing ventilation or vent exhaust gases through charcoal adsorbers and/or HEPA filters for the purpose of removing iodines or particulates from the gaseous exhaust stream prior to the release to the environment (such a system is not considered to have any effect on noble gas effluents). Engineered Safety Feature (ESF) atmospheric cleanup systems are not considered to be VENTILATION EXHAUST TREATMENT SYSTEM components.

3.19 VENTING

VENTING is the controlled process of discharging air or gas from a confinement to maintain temperature, pressure, humidity, concentration, or other operating condition, in such a manner that replacement air or gas is not provided or required during VENTING. Vent, used in system names, does not imply a VENTING process.

3.20 WASTE GAS HOLDUP SYSTEM

A WASTE GAS HOLDUP SYSTEM is any system designed and installed to reduce radioactive gaseous effluents by collecting Reactor Coolant System offgases from the Reactor Coolant System and providing for delay or holdup for the purpose of reducing the total radioactivity prior to release to the environment.

Table 3.1 - FREQUENCY NOTATION

NOTATION FREQUENCY

S	At least once per 12 hours.
D	At least once per 24 hours.
W	At least once per 7 days.
M	At least once per 31 days.
Q	At least once per 92 days.
SA	At least once per 184 days.
3Q	At least once per 276 days.
Y	At least once per 365 days.
R	At least once per 18 months.
N/A	Not applicable.
P	Completed prior to each release.

Table 3.2 - OPERATIONAL MODES

MODE	REACTIVITY CONDITION, K_{eff}	% RATED THERMAL POWER*	AVERAGE COOLANT TEMPERATURE
1. Power Operation	≥ 0.99	$> 5\%$	N/A
2. Startup	≥ 0.99	$\leq 5\%$	N/A
3. Hot Standby	< 0.99	N/A	$\geq 350^\circ\text{F}$
4. Hot Shutdown**	< 0.99	N/A	$350^\circ\text{F} > T_{avg} > 200^\circ\text{F}$
5. Cold Shutdown**	< 0.99	N/A	$\leq 200^\circ\text{F}$
6. Refueling***	N/A	N/A	N/A

* Excluding decay heat.

** All reactor vessel head closure bolts fully tensioned.

*** One or more reactor vessel head closure bolts less than fully tensioned.

Figure 3.1 - WBN SITE AREA MAP

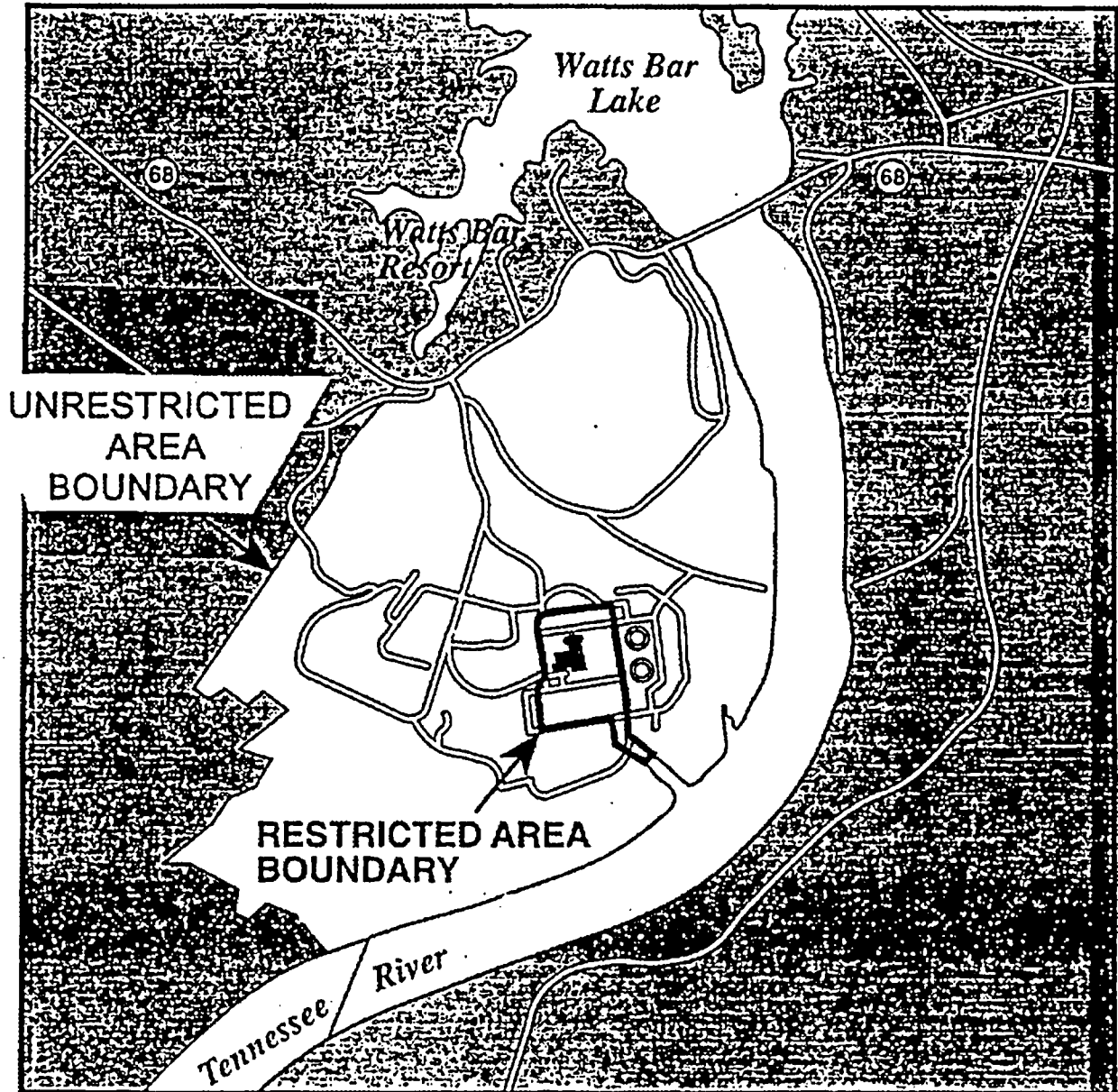

4.0 - (NOT USED)

5.0 ADMINISTRATIVE CONTROLS

5.1 ANNUAL RADIOLOGICAL ENVIRONMENTAL OPERATING REPORT

As required by WBN TS 5.9.2, Routine Annual Radiological Environmental Operating Reports covering the operation of the unit during the previous calendar year shall be submitted prior to May 15 of each year.

The annual radiological environmental operating reports shall include summaries, interpretations, and an analysis of trends of the results of the radiological environmental surveillance activities for the report period, including a comparison with preoperational studies, with operational controls, and with previous environmental surveillance reports and an assessment of the observed impacts of the plant operation on the environment. The reports shall also include the results of land use censuses required by ODCM Control 1.3.2.

The annual radiological environmental operating reports shall include summarized and tabulated results of these analyses and measurements in the format of the table in the Radiological Assessment Branch Technical Position, Revision 1, November 1979. In the event that some results are not available for inclusion with the report, the report shall be submitted noting and explaining the reasons for the missing results. The missing data shall be submitted as soon as possible in a supplementary report.

The reports shall also include the following: a summary description of the radiological environmental monitoring program; at least two legible maps (one map shall cover stations near the UNRESTRICTED AREA BOUNDARY, a second shall include the more distant stations) covering all sampling locations keyed to a table giving distances and directions from the centerline of one reactor; and the results of licensee participation in the Interlaboratory Comparison Program and the corrective actions being taken if the specified program is not being performed as required by ODCM Control 1.3.1; discussion of all deviations from the sampling schedule of Table 2.3-1; reasons for not conducting the radiological environmental monitoring program as required by ODCM Control 1.3.1 and discussions of environmental sample measurements that exceed the reporting levels of Table 2.3-2 but are not the result of plant effluents, pursuant to action b. of ODCM Control 1.3.1; and discussion of all analyses in which the LLD required by Table 2.3-3 was not achievable.

5.2 ANNUAL RADIOACTIVE EFFLUENT RELEASE REPORT

As required by WBN TS 5.9.3, a Radioactive Effluent Release Report covering the operation of the unit during the previous year shall be submitted prior to May 1 of each year. The period of the first report shall begin with the date of initial criticality.

The Annual Radioactive Effluent Release Report shall include a summary of the quantities of radioactive liquid and gaseous effluents and solid waste released from the units as outlined in Regulatory Guide 1.21, "Measuring, Evaluating, and Reporting Radioactivity in Solid Wastes and Releases of Radioactive Materials in Liquid and Gaseous Effluents from Light-Water-Cooled Nuclear Power Plants," Revision 1, June 1974, with data summarized on a quarterly basis following the format of Appendix B thereof, as applicable. Additional requirements for reporting solid waste are specified in the Process Control Program.

The radioactive effluent release reports shall include a list and description of unplanned releases from the site to UNRESTRICTED AREAS of radioactive materials in gaseous and liquid effluents made during the reporting period.

The radioactive effluent release reports shall include any changes made during the reporting period to the Process Control Program, and to the ODCM pursuant to ODCM Administrative Control 5.3, as well as any major changes to Liquid, Gaseous, or Solid Radwaste Treatment Systems, pursuant to WBN Technical Specifications. It shall also include a listing of new location for dose calculations and/or environmental monitoring identified by the Land Use Census pursuant to ODCM Control 1.3.2.

The radioactive effluent release reports shall also include the following: an explanation as to why the inoperability of liquid or gaseous effluent monitoring instrumentation was not corrected within the time specified in ODCM Controls 1.1.1 or 1.1.2, respectively.

The radioactive effluent release report shall include an annual summary of hourly meteorological data collected over the previous year. This annual summary may be either in the form of an hour-by-hour listing on magnetic tape of wind speed, wind direction, atmospheric stability, and precipitation (if measured), or in the form of joint frequency distributions of wind speed, wind direction, and atmospheric stability. In lieu of submission with the radioactive effluent release report, this summary of required meteorological data may be retained on site in a file that shall be provided to NRC upon request. This same report shall include an assessment of the radiation doses due to radioactive liquid and gaseous effluents released from the unit or station during the previous calendar year. This same report shall also include an assessment of the radiation doses from radioactive liquid and gaseous effluents to MEMBERS OF THE PUBLIC due to their activities inside the UNRESTRICTED AREA BOUNDARY during the report period. All assumptions used in making these assessments (i.e., specific activity, exposure time, and location) shall be included in these reports. The meteorological conditions concurrent with the time of release of radioactive materials in gaseous effluents, as determined by sampling frequency and measurement, shall be used for determining the gaseous pathway doses. The assessment of radiation doses shall be performed in accordance with Sections 6.6 and 7.7. [SOURCE NOTE 8]

The radioactive effluent release report shall also include an assessment of radiation doses to the likely most exposed MEMBER OF THE PUBLIC from reactor releases and other nearby uranium fuel cycle sources, including doses from primary effluents and direct radiation, for the previous calendar year to show conformance with 40 CFR 190, in accordance with ODCM Section 8.1.

5.3 OFFSITE DOSE CALCULATION MANUAL CHANGES

As required by WBN TS 5.7.2.3, changes to the ODCM:

1. Shall be documented and records of reviews performed shall be retained . This documentation shall contain:
 - a. Sufficient information to support the change together with the appropriate analyses or evaluations justifying the change(s) and
 - b. A determination that the change will maintain the level of radioactive effluent control required by 10 CFR 20.1302, 40 CFR 190, 10 CFR 50.36a, and Appendix I to 10 CFR 50 and not adversely impact the accuracy or reliability of effluent, dose, or setpoint calculations.
2. Shall become effective after review and acceptance by the PORC and the approval of the Plant Manager.
3. Shall be submitted to the NRC in the form of a complete, legible copy of the entire ODCM as a part of or concurrent with the Annual Radioactive Effluent Release Report for the period of the report in which any change to the ODCM was made. Each change shall be identified by markings in the margin of the affected pages, clearly indicating the area of the page that was changed, and shall indicate the date (i.e., month/year) the change was implemented.

Changes to the ODCM shall be performed in accordance with the requirements of Appendix C.

5.4 SPECIAL REPORTS

Special Reports shall be submitted in accordance with 10 CFR Part 50.4.[SOURCE NOTE 16]

5.5 40 CFR 302 REPORTING

Any releases of radioactivity exceeding both the 40 CFR 190 dose limits and 40 CFR 302.4 reportable quantities, shall be reported immediately to the National Response Center in accordance with the requirements given in 40 CFR 302.6.

5.6 CHANGES TO RADWASTE TREATMENT SYSTEM

Licensee-initiated major changes to the Radwaste Treatment Systems (liquid and gaseous) shall be reported to the Commission in the Annual Radioactive Effluent Release Report for the period in which the evaluation was reviewed by the Plant Operations Review Committee (PORC). The discussion of each change shall contain:

1. A summary of the evaluation that led to the determination that the change could be made in accordance with 10 CFR 50.59;
2. Sufficient detailed information to totally support the reason for the change without benefit of additional or supplemental information;
3. A detailed description of the equipment, components, and processes involved and the interfaces with other plant systems;
4. An evaluation of the change, which shows the predicted releases of radioactive materials in liquid and gaseous effluents that differ from those previously evaluated in the Final Safety Analysis Report;
5. An evaluation of the change, which shows that the expected maximum exposures to a MEMBER OF THE PUBLIC in the UNRESTRICTED AREA and to the general population that differ from those previously estimated in the Final Safety Analysis Report;
6. A comparison of the predicted releases of radioactive materials, in liquid and gaseous effluents, to the actual releases for the period prior to when the changes are to be made;
7. An estimate of the exposure to plant operating personnel as a result of the change;
8. Documentation of the fact that the change was reviewed and found acceptable by the PORC.

6.0 - LIQUID EFFLUENTS INTRODUCTION

Radioactive liquid effluents from WBN enter the UNRESTRICTED AREA through the diffusers into the Tennessee River. There are four plant systems from which radioactive effluents are released. These are the Liquid Radwaste Treatment System (LRTS), the Condensate Demineralizer System, the Turbine Building Sump (TBS), and the Units 1 and 2 Steam Generator Blowdown (SGBD). Figure 6.1 provides an outline of these liquid release paths with associated radiation monitors.

The LRTS, the Condensate Demineralizer System and the SGBDs flow into the Cooling Tower Blowdown (CTBD) for dilution. There is a flow element on the CTBD which suspends the release if the flow is less than the minimum 20,000 gpm required for dilution. Each of these release paths is also monitored by a radiation monitor. These monitors perform two main functions: to identify any unexpected radioactivity releases, and to ensure that the concentration limits of ODCM Control 1.2.1.1 are not exceeded. Each monitor has an alarm/trip setpoint which will alarm if the monitor's setpoint is exceeded. Alarm and trip functions are not provided by separate devices, therefore the alarm/trip setpoint is a single calculated value. The monitors on the Radwaste, Condensate Demineralizer, and SGBD systems will alarm and isolate any release which exceeds the alarm/trip setpoint. The TBS radiation monitor will alarm if the setpoint is exceeded, but this monitor does not have an isolation function.

Releases are made as either a batch or continuous release. Releases from Radwaste Tanks (see Figure 6.2) and the Condensate Demineralizer tanks (see Figure 6.3) are made as batch releases. The TBS and SGBD are continuous releases when flow exists.

For batch releases, any tank to be released is sampled for radioactivity, as described in ODCM Section 6.1.1. The tank contents are analyzed to determine the maximum allowable release flow rates to ensure compliance with the concentration limits of ODCM Control 1.2.1.1 as described in ODCM Section 6.1.2. The sampling results are also used to determine a setpoint for the associated radiation monitor for the release in accordance with ODCM Section 6.2.3. Pre-release calculations are performed assuming the minimum dilution flow of 20,000 gpm for conservatism.

For continuous releases, the pathways are sampled for radioactivity periodically, as described in ODCM Section 6.1.1. The samples are analyzed to ensure compliance with the concentration limits of ODCM Control 1.2.1.1, as described in ODCM Section 6.1.2. The sampling results are also used to determine a setpoint for the associated radiation monitor for the release in accordance with ODCM Section 6.2.3. Pre-release calculations for points other than the Turbine Building Sump are performed assuming the minimum dilution flow of 20,000 gpm for conservatism.

Dose calculations are performed for each sampling period, or release, as applicable, to determine compliance with ODCM Control 1.2.1.2 as detailed in ODCM Sections 6.3 and 6.4. Once per month, the projected dose is calculated, as outlined in Section 6.5, to determine compliance with ODCM Control 1.2.1.3. The calculational methodologies are based on the guidance provided in NUREG 0133 and Regulatory Guide 1.109.

The quantities of each radionuclide identified and released are input into a more rigorous calculation methodology, described in ODCM Section 6.6, to determine the individual and population doses to be reported to the NRC in the Annual Radioactive Effluent Release Report. These dose methodologies are based on the guidance provided in Regulatory Guide 1.109.

RELEASE POINTS

Liquid Radwaste Treatment System

The LRTS processes liquid from the Reactor Building and Auxiliary Building Floor Drains, the CVCS Holdup Tanks, the Laundry/Hot Shower, the Waste Condensate Tanks and Chemical Drain Tanks. Figure 6.2 provides a schematic of the Liquid Radwaste System, showing the flow pathways and flow rates. The LRTS has individual release points for each of the tanks. The routine release points for liquid radwaste are the Monitor Tank and the Cask Decontamination Collector Tank (CDCT). The Monitor Tank has a capacity of 20,000 gal and can be released at a maximum design flow rate of 150 gpm. The CDCT has a capacity of 15,000 gal and can be released at a maximum design flow rate of 100 gpm. The Monitor Tank and CDCT discharge to the Cooling Tower Blowdown line as a batch release and are monitored by radiation monitor 0-RE-90-122.

Condensate Demineralizer System

The Condensate Demineralizer System liquid wastes are released from the High Crud Tanks (HCT-A and -B), the Neutralization Tank, and the Non-Reclaimable Waste Tank (NRWT). Figure 6.3 provides a schematic of the Condensate Demineralizer System, showing the flow pathways and flow rates. The HCTs have a capacity of 20,000 gal and a maximum design discharge flow rate of 150 gpm. The Neutralization Tank has a capacity of 20,000 gal and a maximum design discharge flow rate of 100 gpm. The NRWT has a capacity of 11,000 gal and a maximum design discharge flow rate of 30 gpm. Each of these tanks is defined as a release point for the system. When tank contents are required to be permitted for radioactivity, the Condensate Demineralizer System waste is released to the CTBD line and is monitored by radiation monitor 0-RE-90-225.

Turbine Building Sump

The TBS normally releases to the Low Volume Waste Treatment Pond, but can be released to either the Metal Waste Cleaning Ponds or the 35 acre Yard Holding Pond. The TBS has a capacity of 57,783 gal and a design discharge release rate of 2,000 gpm per pump. The TBS is monitored by radiation monitor 0-RE-90-212.

Steam Generator Blowdown

The SGBD is processed in the Steam Generator Blowdown Flash Tanks or SGBD Heat Exchangers. Figure 6.3 provides a schematic of the SGBD System, showing the flow pathways and flow rates. The SGBD discharge has a maximum design flow rate of 65.5 gpm per steam generator when discharging to the Cooling Tower Blowdown. SGBD is recycled or is released to the CTBD line and monitored by radiation monitors 1,2-RE-90-120A and 1,2-RE-90-121.

6.1 LIQUID RELEASES

6.1.1 Pre-Release Analysis

Radwaste and Condensate Demineralizer tanks will be mixed for a period of time (specified in plant procedures) prior to sampling to ensure that a representative sample is obtained. Recirculation times to ensure adequate mixing will be established by testing. Periodically, checks will be made to ensure a representative mixing of tank contents. Prior to any batch release, a grab sample will be taken and analyzed in accordance with Table 2.2-1.

Releases from the steam generator blowdown and turbine building sump are considered continuous. For continuous releases, daily grab or composite samples will be taken on days when releases are being made and analyzed in accordance with Table 2.2-1.

Composite samples are maintained during periods of radioactive discharge from all pathways (as required by Table 2.2-1) to determine the concentration of certain nuclides (H-3, Fe-55, Sr-89, Sr-90, and gross alpha). For those nuclides whose activities are determined from composite samples, the concentrations for the previous composite period can be assumed as the concentration for the next period to perform the calculations in Sections 6.3 and 6.5. The actual measured concentrations will be used for the dose calculations described in Section 6.6.

A maximum allowable waste flow rate, which will ensure compliance with ODCM Control 1.2.1.1, will be determined using Equations 6.1 and 6.2. Setpoints for the release are determined as described in Section 6.2. Dose calculations are performed in accordance with Section 6.3

6.1.2 Effluent Concentration Limits (ECL)-Sum of the Ratios

To determine release parameters to ensure compliance with ODCM Control 1.2.1.1, a sum of the ratios calculation is performed. The sum of the ratios (R) for each release point will be calculated by the following relationship.

$$R = \sum \frac{C_i}{ECL_i} \quad (6.1)$$

where:

R = the sum of the ratios for the release point.

ECL_i = the ECL of radionuclide i, $\mu\text{Ci/ml}$, from 10 CFR 20, Appendix B, Table 2, Column 2.

C_i = concentration of radionuclide i, $\mu\text{Ci/ml}$.

The sum of the ECL ratios must be ≤ 10 following dilution due to the releases from any or all of the release points described above. The ECL ratios for releases from the Turbine Building Sump will be ≤ 10 at the sump.

The following relationship is used to ensure that this criterion is met:

$$R_{TBS} + \frac{f_1 R_1 + f_2 R_2 + f_3 R_3 + f_4 R_4}{F} \leq 10.0 \quad (6.2)$$

where:

R_{TBS} = sum of the ECL ratios of the turbine building sump as determined by equation 6.1.

$f_{1,2,3,4}$ = effluent flow rate for radwaste, condensate demineralizer system and the steam generator blowdowns, respectively, gpm.

$R_{1,2,3,4}$ = sum of ECL ratios for radwaste, condensate demineralizer system and the steam generator blowdowns, respectively, as determined by equation 6.1.

F = dilution flow rate for CTBD. The minimum assumed flow of 20,000 gpm will be used for all pre-release calculations.

6.1.3 Post-Release Analysis

A post-release evaluation will be done using actual release data to ensure that the limits specified in ODCM Control 1.2.1.1 were not exceeded.

A composite list of concentrations (C_i), by nuclide, will be used with the actual waste flow (f) and dilution (F) flow rates (or volumes) during the release. The data will be evaluated to demonstrate compliance with the limits in ODCM Control 1.2.1.1. [SOURCE NOTE 10]

6.2 INSTRUMENT SETPOINTS

Liquid effluent monitor setpoints are determined to ensure that the concentration of radioactive material released at any time from the site to UNRESTRICTED AREAS does not exceed ten times the ECL limits referenced in ODCM Control 1.2.1.1 and to identify any unplanned releases.

The liquid effluent radiation monitors and their setpoint information are outlined below:

Pathway	Monitor	Default Setpoint	Setpoint Limit	ODCM Section
ERCW	0-RE-90-133 0-RE-90-134 0-RE-90-140 0-RE-90-141	2 times background	N/A	6.2.1
Radwaste	0-RE-90-122	N/A	S_{max}	6.2.2
Condensate Demineralizer	0-RE-90-225	N/A	S_{max}	6.2.2
TBS	0-RE-90-212	≤ 2 times background during periods of no primary to secondary leak indication	S_{max}	6.2.2
SGBD	1-RE-90-120A 2-RE-90-120A 1-RE-90-121 2-RE-90-121	≤ 2 times background during periods of no primary to secondary leak indication	S_{max}	6.2.2

6.2.1 Process Discharge Point Monitor Setpoints (0-RE-90-133,-134,-140,-141)

The setpoints for the ERCW monitors (RE-90-133,-134,-140,-141) must ensure that the concentration of radioactive materials released at any time from the site do not exceed the limits given in ODCM Control 1.2.1.1. Since this effluent stream will not routinely contain radioactivity, the setpoints for these monitors will be set at two times background to ensure that any radioactivity is identified. Site procedures will document and control this value.

6.2.2 Release Point Monitor Setpoints (0-RE-90-122; 0-RE-90-225; 0-RE-90-212; 1,2-RE-90-120A,-121)

The radiation monitor for batch release points, the Liquid Radwaste System and the Condensate Demineralizer System, monitors the undiluted waste stream as it comes out of a tank. The purpose of the monitor setpoints for these batch releases is to identify any gamma-emitting release that is larger than expected and would have the potential to exceed the limits after dilution. Setpoints are calculated as described by equations 6.3, 6.4, and 6.5.

The continuous release points, the Steam Generator Blowdowns, and the Turbine Building Sump, will not be releasing gamma-emitting radioactivity unless there is or has been a primary to secondary leak. If this is the case, the continuous release points are monitored to identify any gamma-emitting release that is larger than expected and would have the potential to exceed the ODCM Control 1.2.1.1 concentration limits after dilution. The monitor setpoints are calculated using Equations 6.3, 6.4, and 6.5 when this is the case. When these release points are being treated in this manner, a single release is defined as all effluent released through this point on a continuous bases for a period of time (usually one week). During periods when there is no identified primary to secondary leak, these monitors are set to ≤ 2 times background. Site procedures will document and control these setpoint values.

For each release from a release point, two setpoints are calculated: one based on the monitor response to the contents of the effluent stream (as described below in Equation 6.4); and another based on the predicted response of the monitor to the activity in the release stream if it were large enough to exceed ten times the 10 CFR 20 limits after dilution (as described below in Equation 6.5). A comparison is made between these two calculated setpoints and the lower of the two is used for the release.

6.2.2.1 Expected Response

An expected response (ER) is calculated for the monitor for each release:

$$ER = BKG + \sum_i (E_i C_i) \quad (6.3)$$

where:

BKG = monitor background, cpm. The monitor's background is controlled at an appropriate limit to ensure adequate sensitivity in accordance with site procedures.

E_i = monitor efficiency for nuclide i , cpm per $\mu\text{Ci/ml}$. This term may also be referred to as a response or calibration factor.

C_i = tank concentration of nuclide i , $\mu\text{Ci/ml}$.

6.2.2.2 Expected Response Setpoint

An expected response setpoint S_{ER} is calculated for the monitor for each release:

$$S_{ER} = X \sum_i E_i C_i + X BKG \quad (6.4)$$

where:

X = administrative factors designed to account for expected variations in monitor response and background (as defined in plant procedures). The ranges of values are: $0 < X \leq 2.0$.

6.2.2.3 Calculated Maximum Monitor Setpoint

A second setpoint is calculated for the release based on the predicted response of the monitor to the gamma-emitting activity in the release stream if it were large enough to exceed ODCM Control 1.2.1.1 limits after dilution. This setpoint ensures that the release will be stopped if it exceeds this limit. The maximum calculated setpoint calculation must satisfy the following relationship from NUREG-0133:

$$\frac{sf}{(F+f)} \leq C$$

where:

- C = the effluent concentration limit from 10 CFR 20 Appendix B, Table 2, Column 2, in $\mu\text{Ci/ml}$, represented by a value of 1.
- s = the setpoint, in $\mu\text{Ci/ml}$, of the monitor measuring the radioactivity concentration in the effluent line prior to dilution and subsequent release. The setpoint, which is proportional to the volumetric flow of the effluent line and inversely proportional to the volumetric flow of the dilution stream, represents a value which, if exceeded, would result in release concentrations exceeding the limits of ODCM Control 1.2.1.1 when the effluent enters the Tennessee River.
- f = the flow rate of the waste stream, gpm.
- F = the dilution flow rate, gpm.

To determine the setpoint in cpm, if no dilution is available, then $s \leq C$.

Since C in the above equation represents the concentration equal to the limit, the setpoint s can be replaced by:

$$s = c_a D_{req}$$

where

- c_a = the actual effluent concentration, $\mu\text{Ci/ml}$.
- D_{req} = the required dilution factor.

The required dilution can be defined as:

$$D_{req} = \frac{R}{10 SF}$$

where:

- R = the sum of the ratios for gamma-emitting radionuclides, as determined by equation 6.1.
 10 = a value which implements the concentration limits of ODCM Control 1.2.1.1.
 SF = a safety factor. The range of values for SF is: $0 < SF \leq 1$.

Substituting $c_a D_{req}$ into the above equation for s, substituting 1 for C, and solving for c_a :

$$c_a \leq \frac{10 SF (F + f)}{f R}$$

This value represents the amount that the expected response setpoint would be adjusted upward to account for the downstream dilution. For WBN, a portion of the total dilution flow is allocated to each release point using an allocation factor (AF). To determine the maximum calculated monitor setpoint, S_{max} , in cpm for a release point, the following equation is used:

$$S_{max} = \left\{ \frac{10 SF (f + (AF \times F))}{f R} \right\} (ER - BKG) + BKG \quad (6.5)$$

where:

AF = fraction of dilution flow allocated to this release point. For the TBS, AF = 0. The fractions for the remaining 4 release points are normally defined as the ratio of the allocated CTBD flow for that release point to the total CTBD flow. The CTBD flow allocation fractions for these release points are routinely:

Radwaste	0.6
Condensate demineralizer	0.2
Steam Generator Blowdown (U1)	0.1
Steam Generator Blowdown (U2)	0.1

These allocation factors may be adjusted for a particular release if it is known that there are no releases being made through other release points into the CTBD. For example, if there are no releases being made through the Condensate Demineralizer or either SGBD, the AF for the Radwaste System may be set equal to one.

ER = expected monitor response, cpm, as calculated in Equation 6.3.

BKG = background, cpm.

6.3 CUMULATIVE LIQUID EFFLUENT DOSE CALCULATIONS

Doses due to liquid effluents are calculated for each release for the following age groups: adult (17 years and older), teen (11-17 years), child (1-11 years), infant (0-1 years) (Reference 4); and the following organs: bone, liver, total body, thyroid, skin, kidney, lung, and GI tract.

Using the methodology presented in NUREG-0133, Section 4.3, doses due to liquid effluents are calculated for the ingestion of drinking water and freshwater fish consumption. Due to the amount of recreation along the Tennessee River, a dose for shoreline recreation is also calculated. This recreation dose is calculated by deriving a dose factor for use in the dose equation for the recreation pathway using equations A-4 and A-6 in Regulatory Guide 1.109. Dose factors for these three pathways are calculated as described in Section 6.7. For pathways with no age or organ specific dose factors (i.e., shoreline recreation), the total body dose will be added to the internal organ doses for all age groups. The consumption of freshwater invertebrates and consumption of food crops irrigated with Tennessee River water are not considered significant pathways for the area surrounding WBN (References 9 and 10), so they are not considered in the dose calculations.

The maximum individual dose from drinking water is assumed to be that calculated at the location immediately downstream from the diffuser. The maximum individual dose from fish ingestion is assumed to be that calculated for the consumption of fish caught anywhere between the plant and the 100% mixing point downstream (Table 6.1). The maximum potential recreation dose is calculated for a location immediately downstream of the plant outfall.

The general equation for the dose to an organ j is:

$$D_j = \sum_i A_{ij} T C_i D \quad (6.6)$$

where:

A_{ij} = the total dose factor to the total body or any organ j for nuclide i , mrem/h per $\mu\text{Ci/ml}$. The total dose factor is the sum of the dose factors for water ingestion, fish ingestion, and shoreline recreation, as defined in Section 6.7.

T = the length of time period over which the concentrations and the flows are averaged, h.

C_i = the average concentration of radionuclide i , in undiluted liquid effluent during the time period T from any liquid release, $\mu\text{Ci/ml}$.

D = the near field average dilution factor for C_i during any effluent release. D is calculated by the following equation:

$$D = \frac{f}{0.10 \times \text{RF}} \quad (6.7)$$

where:

f = maximum undiluted liquid waste flow during the release, cfs. For TBS releases, this term is the waste flow into the pond.

0.10 = mixing fraction of effluent in river, defined as the fraction of the riverflow which is available for dilution of the release (Reference 11).

RF = default riverflow, cfs. For each release, this value is set to 25,657 cfs (the average quarterly riverflow recorded from the period 1985-94).

From the four age groups considered, the maximum organ dose is determined by comparing all organ doses for all age groups. The age group with the highest single organ dose is selected as the critical age group. The total body and maximum organ doses for the critical age group are used in the calculation of the cumulative doses described in Section 6.3.1.

6.3.1 Cumulative Doses

Cumulative quarterly and annual sums of all doses are determined for each release to compare to the limits given in ODCM Control 1.2.1.2. These quarterly and annual sums will be the sum of the doses for each release which occurred in that quarter or year. These doses will be used in the comparison to the limits.

6.3.2 Comparison to Limits

The cumulative calendar quarter and calendar year doses are compared to the limits in ODCM Control 1.2.1.2 at least once per 31 days to determine compliance.

6.4 LIQUID WASTE TREATMENT SYSTEM

The LRTS described in the WBN FSAR shall be maintained and operated to keep releases ALARA. A flow diagram for the LRTS is given in Figure 6.2.

6.5 DOSE PROJECTIONS

In accordance with ODCM Surveillance Requirements 2.2.1.3.1 and 2.2.1.3.2, dose projections will be performed at least once per 31 days using the equation below:

$$D = \left\{ \frac{(a+b)}{d} \times 31 \right\} + c \quad (6.8)$$

where:

- D = the 31-day dose projection, mrem.
- a = the cumulative dose for the quarter, mrem.
- b = the projected dose for this release, mrem.
- c = any anticipated additional dose in the next month from other sources, mrem.
- d = current number of days into the quarter up to the time of the release under consideration.

6.6 DOSE CALCULATIONS FOR REPORTING

A complete dose analysis utilizing the total estimated liquid releases for each calendar quarter will be performed and reported as required in ODCM Administrative Control 5.2. Methodology for this analysis is based on the methodology presented in Regulatory Guide 1.109 and is described in this section. The releases are assumed, for this calculation, to be continuous over the 90 day period.

The near-field dilution factor, D_{NF} , used for the quarterly calculations is:

$$D_{NF} = \frac{1}{0.10 \text{ RF}} \quad (\text{for receptors upstream of Tennessee River Mile 510.0}) \quad (6.9)$$

and

$$D_{NF} = \frac{1}{\text{RF}} \quad (\text{for receptors downstream of Tennessee River Mile 510.0}) \quad (6.10)$$

where:

RF = the average actual riverflow for the location at which the dose is being determined, cfs.

0.10 = the fraction of the riverflow available for dilution in the near field, dimensionless (Reference 11).

Note: TRM 510.0 is the point at which the effluent is considered to be fully mixed with the riverflow (Reference 11).

6.6.1 Water Ingestion

Water ingestion doses are calculated for each water supply identified within a 50 mile radius downstream of WBN (Table 6.1). The water ingestion dose equation is based on Regulatory Guide 1.109, Equation 1:

$$D = k \left(\frac{U_{ap} M_p}{F} \right) \sum_i q_i A_{Wai} \exp(-\lambda_i t_d)$$

For WBN, the dilution factor (M_p/F) is replaced by the near field dilution factor (D_{NF}) described by Equations 6.9 and 6.10, and the usage factor (U_{ap}) and dose conversion factors (A_{Wai}) are incorporated into the dose factor (as described in Section 6.7.1). The resulting equation for the water ingestion dose, D_j , in mrem, to organ j is:

$$D_j = 10^6 (9.80E-09) 0.25 \sum_i A_{Wai} q_i D_{NF} \exp(-8.64E04 \lambda_i t_d) \quad (6.11)$$

where:

10^6 = conversion factor, $\mu\text{Ci}/\text{Ci}$.

$9.80E-09$ = conversion factor, cfs per ml/h.

0.25 = fraction of the yearly water consumption in one quarter, dimensionless.

A_{Wai} = dose factor for water ingestion for age group a , nuclide i , mrem/h per $\mu\text{Ci}/\text{ml}$, as calculated in Section 6.7.1.

q_i = quantity of nuclide i released during the quarter, Ci .

D_{NF} = dilution factor, as described above, cfs^{-1} .

λ_i = radiological decay constant of nuclide i , s^{-1} (Table 6.2).

t_d = decay time for water ingestion, equal to the travel time from the plant to the water supply plus one day to account for the time of processing at the water supply (per Regulatory Guide 1.109), d.

$8.64E+04$ = conversion factor, s/d.

6.6.2 Fish Ingestion

Fish ingestion doses are calculated for each identified reach within a 50 mile radius downstream of WBN (Table 6.1). The fish ingestion dose equation is based on Regulatory Guide 1.109, Equation 2:

$$D = k \left(\frac{U_{ap} M_p}{F} \right) \sum_i q_i B_i A_{Faij} \exp(-\lambda_i t_d)$$

For WBN, the dilution factor (M_p/F) is replaced by the near field dilution factor (D_{NF}) described by Equations 6.9 and 6.10, and the usage factor (U_{ap}), bioaccumulation factor (B_i), and dose conversion factors (A_{Faij}) are incorporated into the dose factor (as described in Section 6.7.2). The resulting equation for the fish ingestion dose D_j , in mrem, to organ j is:

$$D_j = 10^6 (9.80E-09) 0.25 \sum_i A_{Faij} q_i D_{NF} \exp(-8.64E04 \lambda_i t_d) \quad (6.12)$$

where:

10^6 = conversion factor, $\mu\text{Ci}/\text{Ci}$.

$9.80E-09$ = conversion factor, cfs per ml/h.

0.25 = fraction of the yearly fish consumption eaten in one quarter, dimensionless.

A_{Faij} = dose factor for fish ingestion for nuclide i , age group a , organ j , mrem/h per $\mu\text{Ci}/\text{ml}$, as calculated in Section 6.7.2.

q_i = quantity of nuclide i released during the quarter, Ci .

D_{NF} = dilution factor, as described above, cfs^{-1} .

λ_i = radiological decay constant of nuclide i , s^{-1} (Table 6.2).

t_d = decay time for fish ingestion, equal to the travel time from the plant to the center of the reach plus one day to account for transit through the food chain and food preparation time (per Regulatory Guide 1.109), d.
8.64E+04 = conversion factor, s/d.

6.6.3 Shoreline Recreation

Recreation doses are calculated for each identified reach within a 50 mile radius downstream of WBN (Table 6.1). It is assumed that the maximum exposed individual spends 500 hours per year on the shoreline at a location immediately downstream from the diffusers. This is a more conservative usage factor than that provided in Regulatory Guide 1.109. It assumes that an individual visits the shoreline for an average of 10 hours per week for 50 weeks per year. The shoreline recreation dose equation is based on Regulatory Guide 1.109, Equation 3:

$$D = k \left(\frac{U_{ap} M_p}{F} \right) SWF \sum_i q_i T_i A_{Raij} \left[\exp(-\lambda_i t_d) \right] \left[1 - \exp(-\lambda_i t_b) \right]$$

For WBN, the dilution factor M_p/F is replaced by the near field dilution factor (D_{NF}) described by Equations 6.9 and 6.10, and the usage factor (U_{ap}), shoreline width factor (SWF), radioactive half-life (T_i), dose conversion factor (A_{Raij}) and the second exponential term are incorporated into the dose factor (as described in Section 6.7.3). The resulting equation for the shoreline recreation dose D_j , in mrem, to organ j is:

$$D_j = 10^6 (9.80E-09) rf \sum_i A_{Raij} q_i D_{NF} \exp(-8.64E04 \lambda_i t_d) \quad (6.13)$$

where:

10^6 = conversion factor, $\mu\text{Ci}/\text{Ci}$.

$9.80E-09$ = conversion factor, cfs per ml/h.

rf = recreation factor, used to account for the fact that the same amount of time will not be spent at a recreation site during each quarter (Reference 25). Recreation factors used are:

1st quarter - 0.1

2nd quarter - 0.3

3rd quarter - 0.4

4th quarter - 0.2.

A_{Raij} = dose factor for shoreline recreation for nuclide i , age group a , organ j , mrem/h per $\mu\text{Ci}/\text{ml}$, as calculated in Section 6.7.3.

q_i = quantity of nuclide i released during the quarter, Ci.

D_{NF} = dilution factor, as described above, cfs^{-1}

λ_i = radiological decay constant of nuclide i , s^{-1} (Table 6.2).

t_d = decay time for recreation, equal to the travel time from the plant to the center of the reach, d.

$8.64E+04$ = conversion factor, s/d.

6.6.4 Total Maximum Individual Dose

The total maximum individual quarterly total body dose for each age group a , $D(\text{tb})_a$, is obtained using the following equation:

$$D(\text{tb})_a = D_W + D_F + D_R \quad (6.14)$$

where:

D_W = the highest total body water ingestion dose for age group a from among all the public water supplies

D_F = the highest total body fish ingestion dose for age group a from among all the reaches

D_R = the total body maximum shoreline recreation dose.

The total maximum individual quarterly organ dose for each age group a and each organ j , $D(\text{org})_{aj}$, is obtained using the following equation:

$$D(\text{org})_{aj} = D_W + D_F + D_R \quad (6.15)$$

where:

D_W = the highest water ingestion dose for age group a and organ j from among all the public water supplies

D_F = the highest fish ingestion dose for age group a and organ j from among all the reaches

D_R = the maximum shoreline recreation dose for organ j . The total body dose is used for all organs except skin.

The doses reported are the highest total body dose (selected from all age groups) and the highest maximum organ dose (selected from all remaining organs and all age groups).

6.6.5 Population Doses

For determining population doses to the 50-mile population around the plant, an average dose is calculated for each age group and each pathway and then multiplied by the population and the fraction of the population in each age group. The population dose is determined using equation D-1 from Regulatory Guide 1.109:

$$D = k \sum_m \text{POP}_m \sum_a D_{jma} fP_a$$

For WBN, the average individual doses (D_{jma}) are determined by obtaining the ratio of the average consumption rate to the maximum consumption rate and multiplying this by the maximum individual dose. For water ingestion, the general equation used for calculating the population doses, POPWTR, in person-rem for a given Public Water Supply (PWS) is:

$$\text{POPWTR}_j = 10^{-3} \sum_{m=1}^3 \text{POP}_m \sum_{a=1}^4 fP_a \text{ATMW}_a \text{TWDOS}_{amj} \quad (6.16)$$

where:

POPWTR_j = water ingestion population dose to organ j, person-rem.

fP_a = fraction of population in each age group a (from NUREG CR-1004, table 3.39).

Adult = 0.665

Child = 0.168

Infant = 0.015

Teen = 0.153

POP_m = population at PWS m. The 3 PWSs and their populations are listed in Table 6.1.

ATMW_a = ratio of average to maximum water ingestion rates for each age group a. The values for maximum water ingestion rates are given as U_{wa} in Table 6.3. Average water ingestion rates, in L/y, (from Reference 4, Table E-4) are:

Adult = 370

Child = 260

Infant = 260

Teen = 260

TWDOS_{amj} = total individual water ingestion dose to organ j at PWS m, to the age group a (calculated as described in Section 6.6.1), mrem.

10^{-3} = conversion factor for rem/mrem.

For population doses resulting from fish ingestion the calculation assumes that all fish caught within a 50-mile radius downstream of WBN are consumed by local population. The total fish harvest is calculated by multiplying the average fish harvest for the Tennessee River (HVST) by the size of the river reach under consideration (APR). These terms replace POP_m . The general equation for calculating population doses, POPF, in person-rem from fish ingestion of all fish caught within a 50-mile radius downstream is:

$$\text{POPF}_j = 10^{-3} 10^{-3} 453.6 \text{HVST APR} \sum_{r=1}^4 \sum_{a=1}^3 \frac{\text{TFDOS}_{arj} fP_a}{\text{FISH}_a fP_a} \quad (6.17)$$

where:

POPF_j = total fish ingestion population dose to organ j, person-rem.

HVST = fish harvest for the Tennessee River, 3.04 lbs/acre/y edible weight (Reference 12).

APR = size of reach, acres (Table 6.1).

TFDOS_{arj} = total fish ingestion dose to organ j for reach r, for the age group a, (calculated as described in Section 6.6.2), mrem.

fP_a = fraction of population in each age group a, as given above.

FISH_a = amount of fish ingested by each age group a, kg/y. Average fish ingestion rates, kg/y (Reference 4, Table E-4) are:

Adult = 6.9
 Child = 2.2
 Teen = 5.2
 Infant = 0.0

453.6 = conversion factor, g/lb.
 10^{-3} = conversion factor, rem/mrem.
 10^{-3} = conversion factor, kg/g.

For shoreline recreation, the total recreation dose is determined by multiplying the average dose rate (TSHDOS) to an individual by the number of visits to that river reach (SHVIS) and the length of the average visit (HRSVIS). The general equation used for calculating the population doses, POPR, in person-rem is:

$$POPR_j = \frac{rf}{10^3 \cdot 8760} \sum_{r=1}^4 TSHDOS_{ij} SHVIS_r HRSVIS_r \quad (6.18)$$

where:

POPR_j = total recreation population dose for all reaches to organ j, person-rem.
 rf = fraction of yearly recreation which occurs in that quarter, as given in Section 6.6.3.
 TSHDOS_{ij} = total shoreline dose rate for organ j, in reach r, mrem/h.
 SHVIS_r = shoreline visits per year at each reach r, (Table 6.1).
 HRSVIS_r = length of average shoreline recreation visit at reach r, 5 hours.
 10^3 = conversion factor, mrem/rem.
 8760 = conversion factor, h/y.

6.7 LIQUID DOSE FACTOR EQUATIONS

The general form of the liquid dose factor equation from NUREG-0133 is:

$$A_i = k_0 \left(\frac{U_w}{D_w} + U_f BF_i + U_I BF_i \right) DF_i$$

where:

k_0 = conversion factors.

U_w = water consumption rate, L/y.

D_w = dilution factor from the near field area within one-quarter mile of the release point to the potable water intake for water consumption, dimensionless.

U_f = fish consumption rate, kg/y.

BF_i = bioaccumulation factor for nuclide i in freshwater fish, pCi/kg per pCi/L.

U_I = invertebrate consumption rate, kg/y.

DF_i = ingestion dose conversion factor, mrem/pCi.

Since the value of the term U_I is negligible, WBN will not be considering the dose from invertebrate ingestion and that portion of the equation is dropped. In addition, a term is added to account for recreation. The near-field dilution factor is assigned a value of 1 in the water ingestion portion of the equation and is not used for WBN due to the use of riverflow as the dilution factor in the dose calculation. The resulting general dose factor equation is:

$$A_i = k_0 (U_w + U_f BF_i) DF_i + k_1 U_R C_s DFG_i$$

where:

$k_{0,1}$ = conversion factors.

U_R = recreation usage factor, h/y.

C_s = accumulation factor for buildup of activity in sediment, pCi/m² per pCi/L.

DFG_i = dose factor for standing on contaminated ground, mrem/h per pCi/m².

The equations for each of the individual pathway dose factors are presented in the following sections.

6.7.1 Water Ingestion Dose Factor - A_{Waij} (mrem/h per μ Ci/ml)

$$A_{Waij} = \frac{10^6 10^3 DF_{aij} U_{wa}}{8760} \quad (6.19)$$

where:

DF_{aij} = ingestion dose conversion factor for nuclide i , age a , organ j , mrem/pCi, (Table 6.4).

U_{wa} = water consumption rate for age group a , L/y, (Table 6.3).

10^6 = conversion factor, pCi/ μ Ci.

10^3 = conversion factor, ml/L.

8760 = conversion factor, h/y.

6.7.2 Fish Ingestion Dose Factor - A_{Faij} (mrem/h per $\mu\text{Ci/ml}$)

$$A_{Faij} = \frac{10^6 10^3 DF_{aij} U_{fa} B_i}{8760} \quad (6.20)$$

where:

DF_{aij} = ingestion dose conversion factor for nuclide i, age a, organ j, mrem/pCi, (Table 6.4).

U_{fa} = fish consumption rate for age group a, kg/y, (Table 6.3).

B_i = bioaccumulation factor for nuclide i, pCi/kg per pCi/L, (Table 6.5).

10^6 = conversion factor, pCi/ μCi .

10^3 = conversion factor, ml/L.

8760 = conversion factor, h/y.

6.7.3 Shoreline Recreation Dose Factor - A_{Raij} (mrem/h per $\mu\text{Ci/ml}$).

Equation A-6 in Regulatory Guide 1.109 provides a methodology for calculating the dose due to shoreline recreation along a water body:

$$\text{Dose} = k K_c U \text{SWF} \sum_i C_{iw} T_i \text{DFG}_i [1 - \exp(-\lambda_i t_b)]$$

Since the terms C_{iw} and T are part of the dose equation (Equation 6.6), the equation for the dose factor becomes:

$$A_{Raij} = \left\{ \frac{(10^3 10^6 \text{DFG}_i K_c M \text{SWF} U_R)}{8760 \cdot 3600 \lambda_i} \right\} [1 - \exp(-\lambda_i t_b)] \quad (6.21)$$

where:

DFG_{ij} = dose conversion factor for standing on contaminated ground for nuclide i and organ j (total body and skin), mrem/h per pCi/ m^2 , (Table 6.6).

K_c = transfer coefficient from water to shoreline sediment, L/kg-h, (Table 6.3).

M = mass density of sediment, kg/ m^2 , (Table 6.3).

SWF = shoreline width factor, dimensionless, (Table 6.3).

10^3 = conversion factor, ml/L.

10^6 = conversion factor, pCi/ μCi .

3600 = conversion factor, s/h.

λ_i = decay constant for nuclide i, s^{-1} , (Table 6.2).

t_b = time shoreline is exposed to the concentration of the water, s, (Table 6.3).

U_R = recreation usage factor, 500 h/y.

8760 = conversion factor, h/y.

Table 6.1 - RECEPTORS FOR LIQUID DOSE CALCULATIONS

Tennessee River Reaches Within 50 Mile Radius Downstream of WBN

Name	Beginning TRM	Ending TRM	Size ¹ (acres)	Recreation ² visits/y
Chickamauga Lake (from WBN to 100% mixing point)	528	510 ³	4799	85,200
Chickamauga Lake (from 100% mixing point to Sequoyah Nuclear Plant)	510 ³	484	22101	914,000
Chickamauga Lake (from Sequoyah Nuclear Plant to Chickamauga Dam)	484	471	9889	5,226,700
Nickajack Lake (from Chickamauga Dam to WBN 50-mile radius)	471	460	1799	200,000

TRM - Tennessee River Mile.

¹ Reference 13.² Reference 14.³ 100% Mixing Point (Reference 11).

Public Water Supplies Within 50 Mile Radius Downstream of WBN

Name	TRM	1990 Population
Dayton, TN	504	13,500
Soddy-Daisy/Falling Water Utility District	487	10,000
East Side Utility, TN	473	35,000
Chattanooga, TN	465	167,500

NOTE: Tennessee river mile locations are rounded to the nearest mile for dose calculation purposes.

Table 6.2 - RADIONUCLIDE DECAY AND STABLE ELEMENT TRANSFER DATA
(Page 1 of 3)

Nuclide	Half-Life (minutes)	λ (s ⁻¹)	B _{IV}	F _{mi} (cow)	F _{mi} (goat)	F _n (beef)
H-3	6.46E+06	1.79E-09	4.80E+00	1.00E-02	1.70E-01	1.20E-02
C-14	3.01E+09	3.84E-12	5.50E+00	1.20E-02	1.00E-01	3.10E-02
Na-24	9.00E+02	1.28E-05	5.20E-02	4.00E-02	4.00E-02	3.00E-02
P-32	2.06E+04	5.61E-07	1.10E+00	2.50E-02	2.50E-01	4.60E-02
Cr-51	3.99E+04	2.90E-07	2.50E-04	2.20E-03	2.20E-03	2.40E-03
Mn-54	4.50E+05	2.57E-08	2.90E-02	2.50E-04	2.50E-04	8.00E-04
Mn-56	1.55E+02	7.45E-05	2.90E-02	2.50E-04	2.50E-04	8.00E-04
Fe-55	1.42E+06	8.13E-09	6.60E-04	1.20E-03	1.30E-04	1.20E-02
Fe-59	6.43E+04	1.80E-07	6.60E-04	1.20E-03	1.30E-04	1.20E-02
Co-57	3.90E+05	2.96E-08	9.40E-03	1.00E-03	1.00E-03	1.30E-02
Co-58	1.02E+05	1.13E-07	9.40E-03	1.00E-03	1.00E-03	1.30E-02
Co-60	2.77E+06	4.17E-09	9.40E-03	1.00E-03	1.00E-03	1.30E-02
Ni-63	5.27E+07	2.19E-10	1.90E-02	6.70E-03	6.70E-03	5.30E-02
Ni-65	1.51E+02	7.65E-05	1.90E-02	6.70E-03	6.70E-03	5.30E-02
Cu-64	7.62E+02	1.52E-05	1.20E-01	1.40E-02	1.30E-02	9.70E-04
Zn-65	3.52E+05	3.28E-08	4.00E-01	3.90E-02	3.90E-02	3.00E-02
Zn-69m	8.26E+02	1.40E-05	4.00E-01	3.90E-02	3.90E-02	3.00E-02
Zn-69	5.56E+01	2.08E-04	4.00E-01	3.90E-02	3.90E-02	3.00E-02
Br-82	2.12E+03	5.45E-06	7.60E-01	5.00E-02	5.00E-02	2.60E-02
Br-83	1.43E+02	8.08E-05	7.60E-01	5.00E-02	5.00E-02	2.60E-02
Br-84	3.18E+01	3.63E-04	7.60E-01	5.00E-02	5.00E-02	2.60E-02
Br-85	2.87E+00	4.02E-03	7.60E-01	5.00E-02	5.00E-02	2.60E-02
Rb-86	2.69E+04	4.29E-07	1.30E-01	3.00E-02	3.00E-02	3.10E-02
Rb-88	1.78E+01	6.49E-04	1.30E-01	3.00E-02	3.00E-02	3.10E-02
Rb-89	1.54E+01	7.50E-04	1.30E-01	3.00E-02	3.00E-02	3.10E-02
Sr-89	7.28E+04	1.59E-07	1.70E-02	1.40E-03	1.40E-02	6.00E-04
Sr-90	1.50E+07	7.70E-10	1.70E-02	1.40E-03	1.40E-02	6.00E-04
Sr-91	5.70E+02	2.03E-05	1.70E-02	1.40E-03	1.40E-02	6.00E-04
Sr-92	1.63E+02	7.09E-05	1.70E-02	1.40E-03	1.40E-02	6.00E-04
Y-90	3.85E+03	3.00E-06	2.60E-03	1.00E-05	1.00E-05	4.60E-03
Y-91m	4.97E+01	2.32E-04	2.60E-03	1.00E-05	1.00E-05	4.60E-03
Y-91	8.43E+04	1.37E-07	2.60E-03	1.00E-05	1.00E-05	4.60E-03
Y-92	2.12E+02	5.45E-05	2.60E-03	1.00E-05	1.00E-05	4.60E-03
Y-93	6.06E+02	1.91E-05	2.60E-03	1.00E-05	1.00E-05	4.60E-03
Zr-95	9.22E+04	1.25E-07	1.70E-04	5.00E-06	5.00E-06	3.40E-02
Zr-97	1.01E+03	1.14E-05	1.70E-04	5.00E-06	5.00E-06	3.40E-02
Nb-95	5.05E+04	2.29E-07	9.40E-03	2.50E-03	2.50E-03	2.80E-01
Nb-97	7.21E+01	1.60E-04	9.40E-03	2.50E-03	2.50E-03	2.80E-01
Mo-99	3.96E+03	2.92E-06	1.20E-01	7.50E-03	7.50E-03	1.10E-03
Tc-99m	3.61E+02	3.20E-05	2.50E-01	2.50E-02	2.50E-02	4.00E-01
Tc-101	1.42E+01	8.13E-04	2.50E-01	2.50E-02	2.50E-02	4.00E-01
Ru-103	5.67E+04	2.04E-07	5.00E-02	1.00E-06	1.00E-06	4.00E-01

Table 6.2 - RADIONUCLIDE DECAY AND STABLE ELEMENT TRANSFER DATA
(Page 2 of 3)

Nuclide	Half-Life (minutes)	λ (s ⁻¹)	B _{IV}	F _{mi} (cow)	F _{mi} (goat)	F _{fi} (beef)
Ru-105	2.66E+02	4.34E-05	5.00E-02	1.00E-06	1.00E-06	4.00E-01
Ru-106	5.30E+05	2.18E-08	5.00E-02	1.00E-06	1.00E-06	4.00E-01
Ag-110m	3.60E+05	3.21E-08	1.50E-01	5.00E-02	5.00E-02	1.70E-02
Sb-124	8.67E+04	1.33E-07	N/A	1.50E-03	1.50E-03	N/A
Sb-125	1.46E+06	7.91E-09	N/A	1.50E-03	1.50E-03	N/A
Te-125m	8.35E+04	1.38E-07	1.30E+00	1.00E-03	1.00E-03	7.70E-02
Te-127m	1.57E+05	7.36E-08	1.30E+00	1.00E-03	1.00E-03	7.70E-02
Te-127	5.61E+02	2.06E-05	1.30E+00	1.00E-03	1.00E-03	7.70E-02
Te-129m	4.84E+04	2.39E-07	1.30E+00	1.00E-03	1.00E-03	7.70E-02
Te-129	6.96E+01	1.66E-04	1.30E+00	1.00E-03	1.00E-03	7.70E-02
Te-131m	1.80E+03	6.42E-06	1.30E+00	1.00E-03	1.00E-03	7.70E-02
Te-131	2.50E+01	4.62E-04	1.30E+00	1.00E-03	1.00E-03	7.70E-02
Te-132	4.69E+03	2.46E-06	1.30E+00	1.00E-03	1.00E-03	7.70E-02
I-130	7.42E+02	1.56E-05	2.00E-02	1.20E-02	4.30E-01	2.90E-03
I-131	1.16E+04	9.96E-07	2.00E-02	1.20E-02	4.30E-01	2.90E-03
I-132	1.38E+02	8.37E-05	2.00E-02	1.20E-02	4.30E-01	2.90E-03
I-133	1.25E+03	9.24E-06	2.00E-02	1.20E-02	4.30E-01	2.90E-03
I-134	5.26E+01	2.20E-04	2.00E-02	1.20E-02	4.30E-01	2.90E-03
I-135	3.97E+02	2.91E-05	2.00E-02	1.20E-02	4.30E-01	2.90E-03
Cs-134	1.08E+06	1.06E-08	1.00E-02	8.00E-03	3.00E-01	1.50E-02
Cs-136	1.90E+04	6.08E-07	1.00E-02	8.00E-03	3.00E-01	1.50E-02
Cs-137	1.59E+07	7.26E-10	1.00E-02	8.00E-03	3.00E-01	1.50E-02
Cs-138	3.22E+01	3.59E-04	1.00E-02	8.00E-03	3.00E-01	1.50E-02
Ba-139	8.31E+01	1.39E-04	5.00E-03	4.00E-04	4.00E-04	3.20E-03
Ba-140	1.84E+04	6.28E-07	5.00E-03	4.00E-04	4.00E-04	3.20E-03
Ba-141	1.83E+01	6.31E-04	5.00E-03	4.00E-04	4.00E-04	3.20E-03
Ba-142	1.07E+01	1.08E-03	5.00E-03	4.00E-04	4.00E-04	3.20E-03
La-140	2.41E+03	4.79E-06	2.50E-03	5.00E-06	5.00E-06	2.00E-04
La-142	9.54E+01	1.21E-04	2.50E-03	5.00E-06	5.00E-06	2.00E-04
Ce-141	4.68E+04	2.47E-07	2.50E-03	1.00E-04	1.00E-04	1.20E-03
Ce-143	1.98E+03	5.83E-06	2.50E-03	1.00E-04	1.00E-04	1.20E-03
Ce-144	4.09E+05	2.82E-08	2.50E-03	1.00E-04	1.00E-04	1.20E-03
Pr-143	1.95E+04	5.92E-07	2.50E-03	5.00E-06	5.00E-06	4.70E-03
Pr-144	1.73E+01	6.68E-04	2.50E-03	5.00E-06	5.00E-06	4.70E-03
Nd-147	1.58E+04	7.31E-07	2.40E-03	5.00E-06	5.00E-06	3.30E-03
W-187	1.43E+03	8.08E-06	1.80E-02	5.00E-04	5.00E-04	1.30E-03
Np-239	3.39E+03	3.41E-06	2.50E-03	5.00E-06	5.00E-06	2.00E-04
Ar-41	1.10E+02	1.05E-04	N/A	N/A	N/A	N/A
Kr-83m	1.10E+02	1.05E-04	N/A	N/A	N/A	N/A
Kr-85m	2.69E+02	4.29E-05	N/A	N/A	N/A	N/A
Kr-85	5.64E+06	2.05E-09	N/A	N/A	N/A	N/A
Kr-87	7.63E+01	1.51E-04	N/A	N/A	N/A	N/A

Table 6.2 - RADIONUCLIDE DECAY AND STABLE ELEMENT TRANSFER DATA
(Page 3 of 3)

Nuclide	Half-Life (minutes)	λ (s ⁻¹)	B _{IV}	F _{mi} (cow)	F _{mi} (goat)	F _n (beef)
Kr-88	1.70E+02	6.79E-05	N/A	N/A	N/A	N/A
Kr-89	3.16E+00	3.66E-03	N/A	N/A	N/A	N/A
Kr-90	5.39E-01	2.14E-02	N/A	N/A	N/A	N/A
Xe-131m	1.70E+04	6.79E-07	N/A	N/A	N/A	N/A
Xe-133m	3.15E+03	3.67E-06	N/A	N/A	N/A	N/A
Xe-133	7.55E+03	1.53E-06	N/A	N/A	N/A	N/A
Xe-135m	1.54E+01	7.50E-04	N/A	N/A	N/A	N/A
Xe-135	5.47E+02	2.11E-05	N/A	N/A	N/A	N/A
Xe-137	3.83E+00	3.02E-03	N/A	N/A	N/A	N/A
Xe-138	1.41E+01	8.19E-04	N/A	N/A	N/A	N/A

References:

All nuclides half-lives from: Reference 15.

Transfer factors for Sb- isotopes: Reference 16 Table 2-7.

Cow-milk transfer factors for I, Sr, and Cs nuclides are from Reference 21, Table 3.17.

Goat-milk transfer factors for I nuclides are from Reference 21, Table 3.17.

Beef transfer factors for Fe, Cu, Mo, and Cs nuclides are from Reference 21, Table 3.18.

All other nuclides transfer factors are from Reference 4, Tables E-1 and E-2.

Table 6.3 - DOSE CALCULATION FACTORS
(Page 1 of 2)

Factor	Value	Units	Reference
BR _a (infant)	1400	m ³ /y	Reference 20
BR _a (child)	5500	m ³ /y	Reference 20
BR _a (teen)	8000	m ³ /y	Reference 20
BR _a (adult)	8100	m ³ /y	Reference 20
f _g	1		Conservatively assumes all stored vegetables are grown locally.
f _l	1		Reference 4 (Table E-15)
f _p	1		see Note
f _s	0		see Note
H	9	g/m ³	TVA Value
K _c	0.072	L/kg-h	Reference 4 (Section 2.C.)
M	40	kg/m ²	Reference 4 (Section 2.C.)
P	240	kg/m ²	Reference 4 (Table E-15)
Q _r (cow)	64	kg/day	Reference 21 (Sect. 3.4)
Q _r (goat)	08	kg/day	Reference 21 (Sect. 3.4)
r	0.47		Reference 21 (Sect. 3.2)
t _b	4.73E+08 (15 y)	s	Reference 4 (Table E-15)
t _{cb}	7.78E+06 (90 d)	s	Reference 10, Section 11.3.9.1
t _{caf}	1.56E+07 (180 d)	s	Reference 10, Section 11.3.9.1
t _c	5.18E+06 (60 d)	s	Reference 4 (Table E-15)
t _{cp}	2.59E+06 (30 d)	s	Reference 4 (Table E-15)
t _{caf}	7.78E+06 (90 d)	s	Reference 4 (Table E-15)
t _{fm}	8.64E+04 (1 d)	s	Reference 10, Section 11.3.9.1
t _{hc}	8.64E+04 (1 d)	s	Reference 21, Table 3.40
t _s	1.12E+06(13 d)	s	Reference 21, Table 3.40
t _{sv}	2.38E+07(275 d)	s	Reference 10, Section 11.3.9.1
U _{am} (infant)	0	kg/y	Reference 4 (Table E-5)
U _{am} (child)	41	kg/y	Reference 4 (Table E-5)
U _{am} (teen)	65	kg/y	Reference 4 (Table E-5)
U _{am} (adult)	110	kg/y	Reference 4 (Table E-5)

Note: Calculations for release permits use the conservative value given in the table for these parameters. The calculations performed for reporting purposes (as described in Section 7.7) use actual grazing percentages identified in the land use census.

Table 6.3 - DOSE CALCULATION FACTORS
(Page 2 of 2)

Factor	Value	Units	Reference
U_{ap} (infant)	330	L/y	Reference 4 (Table E-5)
U_{ap} (child)	330	L/y	Reference 4 (Table E-5)
U_{ap} (teen)	400	L/y	Reference 4 (Table E-5)
U_{ap} (adult)	310	L/y	Reference 4 (Table E-5)
U_{fa} (infant)	0	kg/y	Reference 4 (Table E-5)
U_{fa} (child)	6.9	kg/y	Reference 4 (Table E-5)
U_{fa} (teen)	16	kg/y	Reference 4 (Table E-5)
U_{fa} (adult)	21	kg/y	Reference 4 (Table E-5)
U_{FLa} (infant)	0	kg/y	Reference 4 (Table E-5)
U_{FLa} (child)	26	kg/y	Reference 4 (Table E-5)
U_{FLa} (teen)	42	kg/y	Reference 4 (Table E-5)
U_{FLa} (adult)	64	kg/y	Reference 4 (Table E-5)
U_{Sa} (infant)	0	kg/y	Reference 4 (Table E-5)
U_{Sa} (child)	520	kg/y	Reference 4 (Table E-5)
U_{Sa} (teen)	630	kg/y	Reference 4 (Table E-5)
U_{Sa} (adult)	520	kg/y	Reference 4 (Table E-5)
U_{Wa} (infant)	330	L/y	Reference 4 (Table E-5)
U_{Wa} (child)	510	L/y	Reference 4 (Table E-5)
U_{Wa} (teen)	510	L/y	Reference 4 (Table E-5)
U_{Wa} (adult)	730	L/y	Reference 4 (Table E-5)
SWF	0.2	none	Reference 4 (Table A-2)
Y_f	1.85	kg/m ²	Reference 21 (Table 3.4)
Y_p	1.18	kg/m ²	Reference 21 (Table 3.3)
Y_{sf}	0.64	kg/m ²	Reference 21 (Table 3.3)
Y_{sv}	0.57	kg/m ²	Reference 21 (Table 3.4) (value selected is for non-leafy vegetables)
λ_w (iodines)	7.71E-07 (15.4 d half-life)	s ⁻¹	Reference 21 (Table 3.10)
λ_w (particulates)	5.21E-07 (10.4 d half-life)	s ⁻¹	Reference 21 (Table 3.10)

Table 6.4 - INGESTION DOSE FACTORS - DF_{aij}
(mrem/pCi ingested) (Page 1 of 8)
ADULT

Nuclide	bone	liver	total body	thyroid	kidney	lung	GI-LLI
H-3	1.05E-07	1.05E-07	1.05E-07	1.05E-07	1.05E-07	1.05E-07	1.05E-07
C-14	2.84E-06	5.68E-07	5.68E-07	5.68E-07	5.68E-07	5.68E-07	5.68E-07
Na-24	1.70E-06	1.70E-06	1.70E-06	1.70E-06	1.70E-06	1.70E-06	1.70E-06
P-32	1.93E-04	1.20E-05	7.46E-06	0.00E+00	0.00E+00	0.00E+00	2.17E-05
Cr-51	0.00E+00	0.00E+00	2.66E-09	1.59E-09	5.86E-10	3.53E-09	6.69E-07
Mn-54	0.00E+00	4.57E-06	8.72E-07	0.00E+00	1.36E-06	0.00E+00	1.40E-05
Mn-56	0.00E+00	1.15E-07	2.04E-08	0.00E+00	1.46E-07	0.00E+00	3.67E-06
Fe-55	2.75E-06	1.90E-06	4.43E-07	0.00E+00	0.00E+00	1.06E-06	1.09E-06
Fe-59	4.34E-06	1.02E-05	3.91E-06	0.00E+00	0.00E+00	2.85E-06	3.40E-05
Co-57	0.00E+00	1.75E-07	2.91E-07	0.00E+00	0.00E+00	0.00E+00	4.44E-06
Co-58	0.00E+00	7.45E-07	1.67E-06	0.00E+00	0.00E+00	0.00E+00	1.51E-05
Co-60	0.00E+00	2.14E-06	4.72E-06	0.00E+00	0.00E+00	0.00E+00	4.02E-05
Ni-63	1.30E-04	9.01E-06	4.36E-06	0.00E+00	0.00E+00	0.00E+00	1.88E-06
Ni-65	5.28E-07	6.86E-08	3.13E-08	0.00E+00	0.00E+00	0.00E+00	1.74E-06
Cu-64	0.00E+00	8.33E-08	3.91E-08	0.00E+00	2.10E-07	0.00E+00	7.10E-06
Zn-65	4.84E-06	1.54E-05	6.96E-06	0.00E+00	1.03E-05	0.00E+00	9.70E-06
Zn-69	1.03E-08	1.97E-08	1.37E-09	0.00E+00	1.28E-08	0.00E+00	2.96E-09
Zn-69m	1.70E-07	4.08E-07	3.73E-08	0.00E+00	2.47E-07	0.00E+00	2.49E-05
Br-82	0.00E+00	0.00E+00	2.26E-06	0.00E+00	0.00E+00	0.00E+00	2.59E-06
Br-83	0.00E+00	0.00E+00	4.02E-08	0.00E+00	0.00E+00	0.00E+00	5.79E-08
Br-84	0.00E+00	0.00E+00	5.21E-08	0.00E+00	0.00E+00	0.00E+00	4.09E-13
Br-85	0.00E+00	0.00E+00	2.14E-09	0.00E+00	0.00E+00	0.00E+00	0.00E+00
Rb-86	0.00E+00	2.11E-05	9.83E-06	0.00E+00	0.00E+00	0.00E+00	4.16E-06
Rb-88	0.00E+00	6.05E-08	3.21E-08	0.00E+00	0.00E+00	0.00E+00	8.36E-19
Rb-89	0.00E+00	4.01E-08	2.82E-08	0.00E+00	0.00E+00	0.00E+00	2.33E-21
Sr-89	3.08E-04	0.00E+00	8.84E-06	0.00E+00	0.00E+00	0.00E+00	4.94E-05
Sr-90	7.58E-03	0.00E+00	1.86E-03	0.00E+00	0.00E+00	0.00E+00	2.19E-04
Sr-91	5.67E-06	0.00E+00	2.29E-07	0.00E+00	0.00E+00	0.00E+00	2.70E-05
Sr-92	2.15E-06	0.00E+00	9.30E-08	0.00E+00	0.00E+00	0.00E+00	4.26E-05
Y-90	9.62E-09	0.00E+00	2.58E-10	0.00E+00	0.00E+00	0.00E+00	1.02E-04
Y-91m	9.09E-11	0.00E+00	3.52E-12	0.00E+00	0.00E+00	0.00E+00	2.67E-10
Y-91	1.41E-07	0.00E+00	3.77E-09	0.00E+00	0.00E+00	0.00E+00	7.76E-05
Y-92	8.45E-10	0.00E+00	2.47E-11	0.00E+00	0.00E+00	0.00E+00	1.48E-05
Y-93	2.68E-09	0.00E+00	7.40E-11	0.00E+00	0.00E+00	0.00E+00	8.50E-05
Zr-95	3.04E-08	9.75E-09	6.60E-09	0.00E+00	1.53E-08	0.00E+00	3.09E-05
Zr-97	1.68E-09	3.39E-10	1.55E-10	0.00E+00	5.12E-10	0.00E+00	1.05E-04
Nb-95	6.22E-09	3.46E-09	1.86E-09	0.00E+00	3.42E-09	0.00E+00	2.10E-05
Nb-97	5.22E-11	1.32E-11	4.82E-12	0.00E+00	1.54E-11	0.00E+00	4.87E-08
Mo-99	0.00E+00	4.31E-06	8.20E-07	0.00E+00	9.76E-06	0.00E+00	9.99E-06
Tc-99m	2.47E-10	6.98E-10	8.89E-09	0.00E+00	1.06E-08	3.42E-10	4.13E-07
Tc-101	2.54E-10	3.66E-10	3.59E-09	0.00E+00	6.59E-09	1.87E-10	1.10E-21
Ru-103	1.85E-07	0.00E+00	7.97E-08	0.00E+00	7.06E-07	0.00E+00	2.16E-05
Ru-105	1.54E-08	0.00E+00	6.08E-09	0.00E+00	1.99E-07	0.00E+00	9.42E-06
Ru-106	2.75E-06	0.00E+00	3.48E-07	0.00E+00	5.31E-06	0.00E+00	1.78E-04

Table 6.4 - INGESTION DOSE FACTORS - DF_{aj}
(mrem/pCi ingested) (Page 2 of 8)
ADULT

Nuclide	bone	liver	total body	thyroid	kidney	lung	GI-LLI
Ag-110m	1.60E-07	1.48E-07	8.79E-08	0.00E+00	2.91E-07	0.00E+00	6.04E-05
Sb-124	2.80E-06	5.29E-08	1.11E-06	6.79E-09	0.00E-00	2.18E-06	7.95E-05
Sb-125	1.79E-06	2.00E-08	4.26E-07	1.82E-09	0.00E-00	1.38E-06	1.97E-05
Te-125m	2.68E-06	9.71E-07	3.59E-07	8.06E-07	1.09E-05	0.00E+00	1.07E-05
Te-127m	6.77E-06	2.42E-06	8.25E-07	1.73E-06	2.75E-05	0.00E+00	2.27E-05
Te-127	1.10E-07	3.95E-08	2.38E-08	8.15E-08	4.48E-07	0.00E+00	8.68E-06
Te-129m	1.15E-05	4.29E-06	1.82E-06	3.95E-06	4.80E-05	0.00E+00	5.79E-05
Te-129	3.14E-08	1.18E-08	7.65E-09	2.41E-08	1.32E-07	0.00E+00	2.37E-08
Te-131m	1.73E-06	8.46E-07	7.05E-07	1.34E-06	8.57E-06	0.00E+00	8.40E-05
Te-131	1.97E-08	8.23E-09	6.22E-09	1.62E-08	8.63E-08	0.00E+00	2.79E-09
Te-132	2.52E-06	1.63E-06	1.53E-06	1.80E-06	1.57E-05	0.00E+00	7.71E-05
I-130	7.56E-07	2.23E-06	8.80E-07	1.89E-04	3.48E-06	0.00E+00	1.92E-06
I-131	4.16E-06	5.95E-06	3.41E-06	1.95E-03	1.02E-05	0.00E+00	1.57E-06
I-132	2.03E-07	5.43E-07	1.90E-07	1.90E-05	8.65E-07	0.00E+00	1.02E-07
I-133	1.42E-06	2.47E-06	7.53E-07	3.63E-04	4.31E-06	0.00E+00	2.22E-06
I-134	1.06E-07	2.88E-07	1.03E-07	4.99E-06	4.58E-07	0.00E+00	2.51E-10
I-135	4.43E-07	1.16E-06	4.28E-07	7.65E-05	1.86E-06	0.00E+00	1.31E-06
Cs-134	6.22E-05	1.48E-04	1.21E-04	0.00E+00	4.79E-05	1.59E-05	2.59E-06
Cs-136	6.51E-06	2.57E-05	1.85E-05	0.00E+00	1.43E-05	1.96E-06	2.92E-06
Cs-137	7.97E-05	1.09E-04	7.14E-05	0.00E+00	3.70E-05	1.23E-05	2.11E-06
Cs-138	5.52E-08	1.09E-07	5.40E-08	0.00E+00	8.01E-08	7.91E-09	4.65E-13
Ba-139	9.70E-08	6.91E-11	2.84E-09	0.00E+00	6.46E-11	3.92E-11	1.72E-07
Ba-140	2.03E-05	2.55E-08	1.33E-06	0.00E+00	8.67E-09	1.46E-08	4.18E-05
Ba-141	4.71E-08	3.56E-11	1.59E-09	0.00E+00	3.31E-11	2.02E-11	2.22E-17
Ba-142	2.13E-08	2.19E-11	1.34E-09	0.00E+00	1.85E-11	1.24E-11	3.00E-26
La-140	2.50E-09	1.26E-09	3.33E-10	0.00E+00	0.00E+00	0.00E+00	9.25E-05
La-142	1.28E-10	5.82E-11	1.45E-11	0.00E+00	0.00E+00	0.00E+00	4.25E-07
Ce-141	9.36E-09	6.33E-09	7.18E-10	0.00E+00	2.94E-09	0.00E+00	2.42E-05
Ce-143	1.65E-09	1.22E-06	1.35E-10	0.00E+00	5.37E-10	0.00E+00	4.56E-05
Ce-144	4.88E-07	2.04E-07	2.62E-08	0.00E+00	1.21E-07	0.00E+00	1.65E-04
Pr-143	9.20E-09	3.69E-09	4.56E-10	0.00E+00	2.13E-09	0.00E+00	4.03E-05
Pr-144	3.01E-11	1.25E-11	1.53E-12	0.00E+00	7.05E-12	0.00E+00	4.33E-18
Nd-147	6.29E-09	7.27E-09	4.35E-10	0.00E+00	4.25E-09	0.00E+00	3.49E-05
W-187	1.03E-07	8.61E-08	3.01E-08	0.00E+00	0.00E+00	0.00E+00	2.82E-05
Np-239	1.19E-09	1.17E-10	6.45E-11	0.00E+00	3.65E-10	0.00E+00	2.40E-05

References:

Dose Factors for Co-57, Zn-69m, Br-82, Nb-97, Sb-124, Sb-125 are from Reference 17, Table 4.
All others are from Reference 4, Table E-11.

NOTE: The tritium dose factor for bone is assumed to be equal to the total body dose factor. This assumes that tritium will act similarly in all organs (Reference 24).

Table 6.4 - INGESTION DOSE FACTORS - DF_{aij}
(mrem/pCi ingested) (Page 3 of 8)
TEEN

Nuclide	bone	liver	total body	thyroid	kidney	lung	GI-LLI
H-3	1.06E-07	1.06E-07	1.06E-07	1.06E-07	1.06E-07	1.06E-07	1.06E-07
C-14	4.06E-06	8.12E-07	8.12E-07	8.12E-07	8.12E-07	8.12E-07	8.12E-07
Na-24	2.30E-06	2.30E-06	2.30E-06	2.30E-06	2.30E-06	2.30E-06	2.30E-06
P-32	2.76E-04	1.71E-05	1.07E-05	0.00E+00	0.00E+00	0.00E+00	2.32E-05
Cr-51	0.00E+00	0.00E+00	3.60E-09	2.00E-09	7.89E-10	5.14E-09	6.05E-07
Mn-54	0.00E+00	5.90E-06	1.17E-06	0.00E+00	1.76E-06	0.00E+00	1.21E-05
Mn-56	0.00E+00	1.58E-07	2.81E-08	0.00E+00	2.00E-07	0.00E+00	1.04E-05
Fe-55	3.78E-06	2.68E-06	6.25E-07	0.00E+00	0.00E+00	1.70E-06	1.16E-06
Fe-59	5.87E-06	1.37E-05	5.29E-06	0.00E+00	0.00E+00	4.32E-06	3.24E-05
Co-57	0.00E+00	2.38E-07	3.99E-07	0.00E+00	0.00E+00	0.00E+00	4.44E-06
Co-58	0.00E+00	9.72E-07	2.24E-06	0.00E+00	0.00E+00	0.00E+00	1.34E-05
Co-60	0.00E+00	2.81E-06	6.33E-06	0.00E+00	0.00E+00	0.00E+00	3.66E-05
Ni-63	1.77E-04	1.25E-05	6.00E-06	0.00E+00	0.00E+00	0.00E+00	1.99E-06
Ni-65	7.49E-07	9.57E-08	4.36E-08	0.00E+00	0.00E+00	0.00E+00	5.19E-06
Cu-64	0.00E+00	1.15E-07	5.41E-08	0.00E+00	2.91E-07	0.00E+00	8.92E-06
Zn-65	5.76E-06	2.00E-05	9.33E-06	0.00E+00	1.28E-05	0.00E+00	8.47E-06
Zn-69	1.47E-08	2.80E-08	1.96E-09	0.00E+00	1.83E-08	0.00E+00	5.16E-08
Zn-69m	2.40E-07	5.66E-07	5.19E-08	0.00E+00	3.44E-07	0.00E+00	3.11E-05
Br-82	0.00E+00	0.00E+00	3.04E-06	0.00E+00	0.00E+00	0.00E+00	0.00E+00
Br-83	0.00E+00	0.00E+00	5.74E-08	0.00E+00	0.00E+00	0.00E+00	0.00E+00
Br-84	0.00E+00	0.00E+00	7.22E-08	0.00E+00	0.00E+00	0.00E+00	0.00E+00
Br-85	0.00E+00	0.00E+00	3.05E-09	0.00E+00	0.00E+00	0.00E+00	0.00E+00
Rb-86	0.00E+00	2.98E-05	1.40E-05	0.00E+00	0.00E+00	0.00E+00	4.41E-06
Rb-88	0.00E+00	8.52E-08	4.54E-08	0.00E+00	0.00E+00	0.00E+00	7.30E-15
Rb-89	0.00E+00	5.50E-08	3.89E-08	0.00E+00	0.00E+00	0.00E+00	8.43E-17
Sr-89	4.40E-04	0.00E+00	1.26E-05	0.00E+00	0.00E+00	0.00E+00	5.24E-05
Sr-90	8.30E-03	0.00E+00	2.05E-03	0.00E+00	0.00E+00	0.00E+00	2.33E-04
Sr-91	8.07E-06	0.00E+00	3.21E-07	0.00E+00	0.00E+00	0.00E+00	3.66E-05
Sr-92	3.05E-06	0.00E+00	1.30E-07	0.00E+00	0.00E+00	0.00E+00	7.77E-05
Y-90	1.37E-08	0.00E+00	3.69E-10	0.00E+00	0.00E+00	0.00E+00	1.13E-04
Y-91m	1.29E-10	0.00E+00	4.93E-12	0.00E+00	0.00E+00	0.00E+00	6.09E-09
Y-91	2.01E-07	0.00E+00	5.39E-09	0.00E+00	0.00E+00	0.00E+00	8.24E-05
Y-92	1.21E-09	0.00E+00	3.50E-11	0.00E+00	0.00E+00	0.00E+00	3.32E-05
Y-93	3.83E-09	0.00E+00	1.05E-10	0.00E+00	0.00E+00	0.00E+00	1.17E-04
Zr-95	4.12E-08	1.30E-08	8.94E-09	0.00E+00	1.91E-08	0.00E+00	3.00E-05
Zr-97	2.37E-09	4.69E-10	2.16E-10	0.00E+00	7.11E-10	0.00E+00	1.27E-04
Nb-95	8.22E-09	4.56E-09	2.51E-09	0.00E+00	4.42E-09	0.00E+00	1.95E-05
Nb-97	7.37E-11	1.83E-11	6.68E-12	0.00E+00	2.14E-11	0.00E+00	4.37E-07
Mo-99	0.00E+00	6.03E-06	1.15E-06	0.00E+00	1.38E-05	0.00E+00	1.08E-05
Tc-99m	3.32E-10	9.26E-10	1.20E-08	0.00E+00	1.38E-08	5.14E-10	6.08E-07
Tc-101	3.60E-10	5.12E-10	5.03E-09	0.00E+00	9.26E-09	3.12E-10	8.75E-17
Ru-103	2.55E-07	0.00E+00	1.09E-07	0.00E+00	8.99E-07	0.00E+00	2.13E-05
Ru-105	2.18E-08	0.00E+00	8.46E-09	0.00E+00	2.75E-07	0.00E+00	1.76E-05
Ru-106	3.92E-06	0.00E+00	4.94E-07	0.00E+00	7.56E-06	0.00E+00	1.88E-04

Table 6.4 - INGESTION DOSE FACTORS - DF_{aj}
(mrem/pCi ingested) (Page 4 of 8)
TEEN

Nuclide	bone	liver	total body	thyroid	kidney	lung	GI-LLI
Ag-110m	2.05E-07	1.94E-07	1.18E-07	0.00E+00	3.70E-07	0.00E+00	5.45E-05
Sb-124	3.87E-06	7.13E-08	1.51E-06	8.78E-09	0.00E-00	3.38E-06	7.80E-05
Sb-125	2.48E-06	2.71E-08	5.80E-07	2.37E-09	0.00E+00	2.18E-06	1.93E-05
Te-125m	3.83E-06	1.38E-06	5.12E-07	1.07E-06	0.00E+00	0.00E+00	1.13E-05
Te-127m	9.67E-06	3.43E-06	1.15E-06	2.30E-06	3.92E-05	0.00E+00	2.41E-05
Te-127	1.58E-07	5.60E-08	3.40E-08	1.09E-07	6.40E-07	0.00E+00	1.22E-05
Te-129m	1.63E-05	6.05E-06	2.58E-06	5.26E-06	6.82E-05	0.00E+00	6.12E-05
Te-129	4.48E-08	1.67E-08	1.09E-08	3.20E-08	1.88E-07	0.00E+00	2.45E-07
Te-131m	2.44E-06	1.17E-06	9.76E-07	1.76E-06	1.22E-05	0.00E+00	9.39E-05
Te-131	2.79E-08	1.15E-08	8.72E-09	2.15E-08	1.22E-07	0.00E+00	2.29E-09
Te-132	3.49E-06	2.21E-06	2.08E-06	2.33E-06	2.12E-05	0.00E+00	7.00E-05
I-130	1.03E-06	2.98E-06	1.19E-06	2.43E-04	4.59E-06	0.00E+00	2.29E-06
I-131	5.85E-06	8.19E-06	4.40E-06	2.39E-03	1.41E-05	0.00E+00	1.62E-06
I-132	2.79E-07	7.30E-07	2.62E-07	2.46E-05	1.15E-06	0.00E+00	3.18E-07
I-133	2.01E-06	3.41E-06	1.04E-06	4.76E-04	5.98E-06	0.00E+00	2.58E-06
I-134	1.46E-07	3.87E-07	1.39E-07	6.45E-06	6.10E-07	0.00E+00	5.10E-09
I-135	6.10E-07	1.57E-06	5.82E-07	1.01E-04	2.48E-06	0.00E+00	1.74E-06
Cs-134	8.37E-05	1.97E-04	9.14E-05	0.00E+00	6.26E-05	2.39E-05	2.45E-06
Cs-136	8.59E-06	3.38E-05	2.27E-05	0.00E+00	1.84E-05	2.90E-06	2.72E-06
Cs-137	1.12E-04	1.49E-04	5.19E-05	0.00E+00	5.07E-05	1.97E-05	2.12E-06
Cs-138	7.76E-08	1.49E-07	7.45E-08	0.00E+00	1.10E-07	1.28E-08	6.76E-11
Ba-139	1.39E-07	9.78E-11	4.05E-09	0.00E+00	9.22E-11	6.74E-11	1.24E-06
Ba-140	2.84E-05	3.48E-08	1.83E-06	0.00E+00	1.18E-08	2.34E-08	4.38E-05
Ba-141	6.71E-08	5.01E-11	2.24E-09	0.00E+00	4.65E-11	3.43E-11	1.43E-13
Ba-142	2.99E-08	2.99E-11	1.84E-09	0.00E+00	2.53E-11	1.99E-11	9.18E-20
La-140	3.48E-09	1.71E-09	4.55E-10	0.00E+00	0.00E+00	0.00E+00	9.82E-05
La-142	1.79E-10	7.95E-11	1.98E-11	0.00E+00	0.00E+00	0.00E+00	2.42E-06
Ce-141	1.33E-08	8.88E-09	1.02E-09	0.00E+00	4.18E-09	0.00E+00	2.54E-05
Ce-143	2.35E-09	1.71E-06	1.91E-10	0.00E+00	7.67E-10	0.00E+00	5.14E-05
Ce-144	6.96E-07	2.88E-07	3.74E-08	0.00E+00	1.72E-07	0.00E+00	1.75E-04
Pr-143	1.31E-08	5.23E-09	6.52E-10	0.00E+00	3.04E-09	0.00E+00	4.31E-05
Pr-144	4.30E-11	1.76E-11	2.18E-12	0.00E+00	1.01E-11	0.00E+00	4.74E-14
Nd-147	9.38E-09	1.02E-08	6.11E-10	0.00E+00	5.99E-09	0.00E+00	3.68E-05
W-187	1.46E-07	1.19E-07	4.17E-08	0.00E+00	0.00E+00	0.00E+00	3.22E-05
Np-239	1.76E-09	1.66E-10	9.22E-11	0.00E+00	5.21E-10	0.00E+00	2.67E-05

References:

Dose Factors for Co-57, Zn-69m, Br-82, Nb-97, Sb-124, Sb-125 are from Reference 9, Table 4.
All others are from Reference 4, Table E-12.

NOTE: The tritium dose factor for bone is assumed to be equal to the total body dose factor. This assumes that tritium will act similarly in all organs (Reference 24).

Table 6.4 - INGESTION DOSE FACTORS - DF_{aij}
(mrem/pCi ingested) (Page 5 of 8)
CHILD

Nuclide	bone	liver	total body	thyroid	kidney	lung	GI-LLI
H-3	2.03E-07	2.03E-07	2.03E-07	2.03E-07	2.03E-07	2.03E-07	2.03E-07
C-14	1.21E-05	2.42E-06	2.42E-06	2.42E-06	2.42E-06	2.42E-06	2.42E-06
Na-24	5.80E-06	5.80E-06	5.80E-06	5.80E-06	5.80E-06	5.80E-06	5.80E-06
P-32	8.25E-04	3.86E-05	3.18E-05	0.00E+00	0.00E+00	0.00E+00	2.28E-05
Cr-51	0.00E+00	0.00E+00	8.90E-09	4.94E-09	1.35E-09	9.02E-09	4.72E-07
Mn-54	0.00E+00	1.07E-05	2.85E-06	0.00E+00	3.00E-06	0.00E+00	8.98E-06
Mn-56	0.00E+00	3.34E-07	7.54E-08	0.00E+00	4.04E-07	0.00E+00	4.84E-05
Fe-55	1.15E-05	6.10E-06	1.89E-06	0.00E+00	0.00E+00	3.45E-06	1.13E-06
Fe-59	1.65E-05	2.67E-05	1.33E-05	0.00E+00	0.00E+00	7.74E-06	2.78E-05
Co-57	0.00E+00	4.93E-07	9.98E-07	0.00E+00	0.00E+00	0.00E+00	4.04E-06
Co-58	0.00E+00	1.80E-06	5.51E-06	0.00E+00	0.00E+00	0.00E+00	1.05E-05
Co-60	0.00E+00	5.29E-06	1.56E-05	0.00E+00	0.00E+00	0.00E+00	2.93E-05
Ni-63	5.38E-04	2.88E-05	1.83E-05	0.00E+00	0.00E+00	0.00E+00	1.94E-06
Ni-65	2.22E-06	2.09E-07	1.22E-07	0.00E+00	0.00E+00	0.00E+00	2.56E-05
Cu-64	0.00E+00	2.45E-07	1.48E-07	0.00E+00	5.92E-07	0.00E+00	1.15E-05
Zn-65	1.37E-05	3.65E-05	2.27E-05	0.00E+00	2.30E-05	0.00E+00	6.41E-06
Zn-69	4.38E-08	6.33E-08	5.85E-09	0.00E+00	3.84E-08	0.00E+00	3.99E-06
Zn-69m	7.10E-07	1.21E-06	1.43E-07	0.00E+00	7.03E-07	0.00E+00	3.94E-05
Br-82	0.00E+00	0.00E+00	7.55E-06	0.00E+00	0.00E+00	0.00E+00	0.00E+00
Br-83	0.00E+00	0.00E+00	1.71E-07	0.00E+00	0.00E+00	0.00E+00	0.00E+00
Br-84	0.00E+00	0.00E+00	1.98E-07	0.00E+00	0.00E+00	0.00E+00	0.00E+00
Br-85	0.00E+00	0.00E+00	9.12E-09	0.00E+00	0.00E+00	0.00E+00	0.00E+00
Rb-86	0.00E+00	6.70E-05	4.12E-05	0.00E+00	0.00E+00	0.00E+00	4.31E-06
Rb-88	0.00E+00	1.90E-07	1.32E-07	0.00E+00	0.00E+00	0.00E+00	9.32E-09
Rb-89	0.00E+00	1.17E-07	1.04E-07	0.00E+00	0.00E+00	0.00E+00	1.02E-09
Sr-89	1.32E-03	0.00E+00	3.77E-05	0.00E+00	0.00E+00	0.00E+00	5.11E-05
Sr-90	1.70E-02	0.00E+00	4.31E-03	0.00E+00	0.00E+00	0.00E+00	2.29E-04
Sr-91	2.40E-05	0.00E+00	9.06E-07	0.00E+00	0.00E+00	0.00E+00	5.30E-05
Sr-92	9.03E-06	0.00E+00	3.62E-07	0.00E+00	0.00E+00	0.00E+00	1.71E-04
Y-90	4.11E-08	0.00E+00	1.10E-09	0.00E+00	0.00E+00	0.00E+00	1.17E-04
Y-91m	3.82E-10	0.00E+00	1.39E-11	0.00E+00	0.00E+00	0.00E+00	7.48E-07
Y-91	6.02E-07	0.00E+00	1.61E-08	0.00E+00	0.00E+00	0.00E+00	8.02E-05
Y-92	3.60E-09	0.00E+00	1.03E-10	0.00E+00	0.00E+00	0.00E+00	1.04E-04
Y-93	1.14E-08	0.00E+00	3.13E-10	0.00E+00	0.00E+00	0.00E+00	1.70E-04
Zr-95	1.16E-07	2.55E-08	2.27E-08	0.00E+00	3.65E-08	0.00E+00	2.66E-05
Zr-97	6.99E-09	1.01E-09	5.96E-10	0.00E+00	1.45E-09	0.00E+00	1.53E-04
Nb-95	2.25E-08	8.76E-09	6.26E-09	0.00E+00	8.23E-09	0.00E+00	1.62E-05
Nb-97	2.17E-10	3.92E-11	1.83E-11	0.00E+00	4.35E-11	0.00E+00	1.21E-05
Mo-99	0.00E+00	1.33E-05	3.29E-06	0.00E+00	2.84E-05	0.00E+00	1.10E-05
Tc-99m	9.23E-10	1.81E-09	3.00E-08	0.00E+00	2.63E-08	9.19E-10	1.03E-06
Tc-101	1.07E-09	1.12E-09	1.42E-08	0.00E+00	1.91E-08	5.92E-10	3.56E-09
Ru-103	7.31E-07	0.00E+00	2.81E-07	0.00E+00	1.84E-06	0.00E+00	1.89E-05
Ru-105	6.45E-08	0.00E+00	2.34E-08	0.00E+00	5.67E-07	0.00E+00	4.21E-05
Ru-106	1.17E-05	0.00E+00	1.46E-06	0.00E+00	1.58E-05	0.00E+00	1.82E-04

Table 6.4 - INGESTION DOSE FACTORS - DF_{aij}
(mrem/pCi ingested) (Page 6 of 8)
CHILD

Nuclide	bone	liver	total body	thyroid	kidney	lung	GI-LLI
Ag-110m	5.39E-07	3.64E-07	2.91E-07	0.00E+00	6.78E-07	0.00E+00	4.33E-05
Sb-124	1.11E-05	1.44E-07	3.89E-06	2.45E-08	0.00E+00	6.16E-06	6.94E-05
Sb-125	7.16E-06	5.52E-08	1.50E-06	6.63E-09	0.00E+00	3.99E-06	1.71E-05
Te-125m	1.14E-05	3.09E-06	1.52E-06	3.20E-06	0.00E+00	0.00E+00	1.10E-05
Te-127m	2.89E-05	7.78E-06	3.43E-06	6.91E-06	8.24E-05	0.00E+00	2.34E-05
Te-127	4.71E-07	1.27E-07	1.01E-07	3.26E-07	1.34E-06	0.00E+00	1.84E-05
Te-129m	4.87E-05	1.36E-05	7.56E-06	1.57E-05	1.43E-04	0.00E+00	5.94E-05
Te-129	1.34E-07	3.74E-08	3.18E-08	9.56E-08	3.92E-07	0.00E+00	8.34E-06
Te-131m	7.20E-06	2.49E-06	2.65E-06	5.12E-06	2.41E-05	0.00E+00	1.01E-04
Te-131	8.30E-08	2.53E-08	2.47E-08	6.35E-08	2.51E-07	0.00E+00	4.36E-07
Te-132	1.01E-05	4.47E-06	5.40E-06	6.51E-06	4.15E-05	0.00E+00	4.50E-05
I-130	2.92E-06	5.90E-06	3.04E-06	6.50E-04	8.82E-06	0.00E+00	2.76E-06
I-131	1.72E-05	1.73E-05	9.83E-06	5.72E-03	2.84E-05	0.00E+00	1.54E-06
I-132	8.00E-07	1.47E-06	6.76E-07	6.82E-05	2.25E-06	0.00E+00	1.73E-06
I-133	5.92E-06	7.32E-06	2.77E-06	1.36E-03	1.22E-05	0.00E+00	2.95E-06
I-134	4.19E-07	7.78E-07	3.58E-07	1.79E-05	1.19E-06	0.00E+00	5.16E-07
I-135	1.75E-06	3.15E-06	1.49E-06	2.79E-04	4.83E-06	0.00E+00	2.40E-06
Cs-134	2.34E-04	3.84E-04	8.10E-05	0.00E+00	1.19E-04	4.27E-05	2.07E-06
Cs-136	2.35E-05	6.46E-05	4.18E-05	0.00E+00	3.44E-05	5.13E-06	2.27E-06
Cs-137	3.27E-04	3.13E-04	4.62E-05	0.00E+00	1.02E-04	3.67E-05	1.96E-06
Cs-138	2.28E-07	3.17E-07	2.01E-07	0.00E+00	2.23E-07	2.40E-08	1.46E-07
Ba-139	4.14E-07	2.21E-10	1.20E-08	0.00E+00	1.93E-10	1.30E-10	2.39E-05
Ba-140	8.31E-05	7.28E-08	4.85E-06	0.00E+00	2.37E-08	4.34E-08	4.21E-05
Ba-141	2.00E-07	1.12E-10	6.51E-09	0.00E+00	9.69E-11	6.58E-10	1.14E-07
Ba-142	8.74E-08	6.29E-11	4.88E-09	0.00E+00	5.09E-11	3.70E-11	1.14E-09
La-140	1.01E-08	3.53E-09	1.19E-09	0.00E+00	0.00E+00	0.00E+00	9.84E-05
La-142	5.24E-10	1.67E-10	5.23E-11	0.00E+00	0.00E+00	0.00E+00	3.31E-05
Ce-141	3.97E-08	1.98E-08	2.94E-09	0.00E+00	8.68E-09	0.00E+00	2.47E-05
Ce-143	6.99E-09	3.79E-06	5.49E-10	0.00E+00	1.59E-09	0.00E+00	5.55E-05
Ce-144	2.08E-06	6.52E-07	1.11E-07	0.00E+00	3.61E-07	0.00E+00	1.70E-04
Pr-143	3.93E-08	1.18E-08	1.95E-09	0.00E+00	6.39E-09	0.00E+00	4.24E-05
Pr-144	1.29E-10	3.99E-11	6.49E-12	0.00E+00	2.11E-11	0.00E+00	8.59E-08
Nd-147	2.79E-08	2.26E-08	1.75E-09	0.00E+00	1.24E-08	0.00E+00	3.58E-05
W-187	4.29E-07	2.54E-07	1.14E-07	0.00E+00	0.00E+00	0.00E+00	3.57E-05
Np-239	5.25E-09	3.77E-10	2.65E-10	0.00E+00	1.09E-09	0.00E+00	2.79E-05

References:

Dose Factors for Co-57, Zn-69m, Br-82, Nb-97, Sb-124, Sb-125 are from Reference 17, Table 4.
All others are from Reference 4, Table E-13.

NOTE: The tritium dose factor for bone is assumed to be equal to the total body dose factor. This assumes that tritium will act similarly in all organs (Reference 24).

Table 6.4 - INGESTION DOSE FACTORS - DF_{aij}
(mrem/pCi ingested) (Page 7 of 8)
INFANT

Nuclide	bone	liver	total body	thyroid	kidney	lung	GI-LLI
H-3	3.08E-07	3.08E-07	3.08E-07	3.08E-07	3.08E-07	3.08E-07	3.08E-07
C-14	2.37E-05	5.06E-06	5.06E-06	5.06E-06	5.06E-06	5.06E-06	5.06E-06
Na-24	1.01E-05	1.01E-05	1.01E-05	1.01E-05	1.01E-05	1.01E-05	1.01E-05
P-32	1.70E-03	1.00E-04	6.59E-05	0.00E+00	0.00E+00	0.00E+00	2.30E-05
Cr-51	0.00E+00	0.00E+00	1.41E-08	9.20E-09	2.01E-09	1.79E-08	4.11E-07
Mn-54	0.00E+00	1.99E-05	4.51E-06	0.00E+00	4.41E-06	0.00E+00	7.31E-06
Mn-56	0.00E+00	8.18E-07	1.41E-07	0.00E+00	7.03E-07	0.00E+00	7.43E-05
Fe-55	1.39E-05	8.98E-06	2.40E-06	0.00E+00	0.00E+00	4.39E-06	1.14E-06
Fe-59	3.08E-05	5.38E-05	2.12E-05	0.00E+00	0.00E+00	1.59E-05	2.57E-05
Co-57	0.00E+00	1.15E-06	1.87E-06	0.00E+00	0.00E+00	0.00E+00	3.92E-06
Co-58	0.00E+00	3.60E-06	8.98E-06	0.00E+00	0.00E+00	0.00E+00	8.97E-06
Co-60	0.00E+00	1.08E-05	2.55E-05	0.00E+00	0.00E+00	0.00E+00	2.57E-05
Ni-63	6.34E-04	3.92E-05	2.20E-05	0.00E+00	0.00E+00	0.00E+00	1.95E-06
Ni-65	4.70E-06	5.32E-07	2.42E-07	0.00E+00	0.00E+00	0.00E+00	4.05E-05
Cu-64	0.00E+00	6.09E-07	2.82E-07	0.00E+00	1.03E-06	0.00E+00	1.25E-05
Zn-65	1.84E-05	6.31E-05	2.91E-05	0.00E+00	3.06E-05	0.00E+00	5.33E-05
Zn-69	9.33E-08	1.68E-07	1.25E-08	0.00E+00	6.98E-08	0.00E+00	1.37E-05
Zn-69m	1.50E-06	3.06E-06	2.79E-07	0.00E+00	1.24E-06	0.00E+00	4.24E-05
Br-82	0.00E+00	0.00E+00	1.27E-05	0.00E+00	0.00E+00	0.00E+00	0.00E+00
Br-83	0.00E+00	0.00E+00	3.63E-07	0.00E+00	0.00E+00	0.00E+00	0.00E+00
Br-84	0.00E+00	0.00E+00	3.82E-07	0.00E+00	0.00E+00	0.00E+00	0.00E+00
Br-85	0.00E+00	0.00E+00	1.94E-08	0.00E+00	0.00E+00	0.00E+00	0.00E+00
Rb-86	0.00E+00	1.70E-04	8.40E-05	0.00E+00	0.00E+00	0.00E+00	4.35E-06
Rb-88	0.00E+00	4.98E-07	2.73E-07	0.00E+00	0.00E+00	0.00E+00	4.85E-07
Rb-89	0.00E+00	2.86E-07	1.97E-07	0.00E+00	0.00E+00	0.00E+00	9.74E-08
Sr-89	2.51E-03	0.00E+00	7.20E-05	0.00E+00	0.00E+00	0.00E+00	5.16E-05
Sr-90	1.85E-02	0.00E+00	4.71E-03	0.00E+00	0.00E+00	0.00E+00	2.31E-04
Sr-91	5.00E-05	0.00E+00	1.81E-06	0.00E+00	0.00E+00	0.00E+00	5.92E-05
Sr-92	1.92E-05	0.00E+00	7.13E-07	0.00E+00	0.00E+00	0.00E+00	2.07E-04
Y-90	8.69E-08	0.00E+00	2.33E-09	0.00E+00	0.00E+00	0.00E+00	1.20E-04
Y-91m	8.10E-10	0.00E+00	2.76E-11	0.00E+00	0.00E+00	0.00E+00	2.70E-06
Y-91	1.13E-06	0.00E+00	3.01E-08	0.00E+00	0.00E+00	0.00E+00	8.10E-05
Y-92	7.65E-09	0.00E+00	2.15E-10	0.00E+00	0.00E+00	0.00E+00	1.46E-04
Y-93	2.43E-08	0.00E+00	6.62E-10	0.00E+00	0.00E+00	0.00E+00	1.92E-04
Zr-95	2.06E-07	5.02E-08	3.56E-08	0.00E+00	5.41E-08	0.00E+00	2.50E-05
Zr-97	1.48E-08	2.54E-09	1.16E-09	0.00E+00	2.56E-09	0.00E+00	1.62E-04
Nb-95	4.20E-08	1.73E-08	1.00E-08	0.00E+00	1.24E-08	0.00E+00	1.46E-05
Nb-97	4.59E-10	9.79E-11	3.53E-11	0.00E+00	7.65E-11	0.00E+00	3.09E-05
Mo-99	0.00E+00	3.40E-05	6.63E-06	0.00E+00	5.08E-05	0.00E+00	1.12E-05
Tc-99m	1.92E-09	3.96E-09	5.10E-08	0.00E+00	4.26E-08	2.07E-09	1.15E-06
Tc-101	2.27E-09	2.86E-09	2.83E-08	0.00E+00	3.40E-08	1.56E-09	4.86E-07
Ru-103	1.48E-06	0.00E+00	4.95E-07	0.00E+00	3.08E-06	0.00E+00	1.80E-05
Ru-105	1.36E-07	0.00E+00	4.58E-08	0.00E+00	1.00E-06	0.00E+00	5.41E-05
Ru-106	2.41E-05	0.00E+00	3.01E-06	0.00E+00	2.85E-05	0.00E+00	1.83E-04

Table 6.4 - INGESTION DOSE FACTORS - DF_{aij}
(mrem/pCi ingested) (Page 8 of 8)
INFANT

Nuclide	bone	liver	total body	thyroid	kidney	lung	GI-LLI
Ag-110m	9.96E-07	7.27E-07	4.81E-07	0.00E+00	1.04E-06	0.00E+00	3.77E-05
Sb-124	2.14E-05	3.15E-07	6.63E-06	5.68E-08	0.00E+00	1.34E-05	6.60E-05
Sb-125	1.23E-05	1.19E-07	2.53E-06	1.54E-08	0.00E+00	7.72E-06	1.64E-05
Te-125m	2.33E-05	7.79E-06	3.15E-06	7.84E-06	0.00E+00	0.00E+00	1.11E-05
Te-127m	5.85E-05	1.94E-05	7.08E-06	1.69E-05	1.44E-04	0.00E+00	2.36E-05
Te-127	1.00E-06	3.35E-07	2.15E-07	8.14E-07	2.44E-06	0.00E+00	2.10E-05
Te-129m	1.00E-04	3.43E-05	1.54E-05	3.84E-05	2.50E-04	0.00E+00	5.97E-05
Te-129	2.84E-07	9.79E-08	6.63E-08	2.38E-07	7.07E-07	0.00E+00	2.27E-05
Te-131m	1.52E-05	6.12E-06	5.05E-06	1.24E-05	4.21E-05	0.00E+00	1.03E-04
Te-131	1.76E-07	6.50E-08	4.94E-08	1.57E-07	4.50E-07	0.00E+00	7.11E-06
Te-132	2.08E-05	1.03E-05	9.61E-06	1.52E-05	6.44E-05	0.00E+00	3.81E-05
I-130	6.00E-06	1.32E-05	5.30E-06	1.48E-03	1.45E-05	0.00E+00	2.83E-06
I-131	3.59E-05	4.23E-05	1.86E-05	1.39E-02	4.94E-05	0.00E+00	1.51E-06
I-132	1.66E-06	3.37E-06	1.20E-06	1.58E-04	3.76E-06	0.00E+00	2.73E-06
I-133	1.25E-05	1.82E-05	5.33E-06	3.31E-03	2.14E-05	0.00E+00	3.08E-06
I-134	8.69E-07	1.78E-06	6.33E-07	4.15E-05	1.99E-06	0.00E+00	1.84E-06
I-135	3.64E-06	7.24E-06	2.64E-06	6.49E-04	8.07E-06	0.00E+00	2.62E-06
Cs-134	3.77E-04	7.03E-04	7.10E-05	0.00E+00	1.81E-04	7.42E-05	1.91E-06
Cs-136	4.59E-05	1.35E-04	5.04E-05	0.00E+00	5.38E-05	1.10E-05	2.05E-06
Cs-137	5.22E-04	6.11E-04	4.33E-05	0.00E+00	1.64E-04	6.64E-05	1.91E-06
Cs-138	4.81E-07	7.82E-07	3.79E-07	0.00E+00	3.90E-07	6.09E-08	1.25E-06
Ba-139	8.81E-07	5.84E-10	2.55E-08	0.00E+00	3.51E-10	3.54E-10	5.58E-05
Ba-140	1.71E-04	1.71E-07	8.81E-06	0.00E+00	4.06E-08	1.05E-07	4.20E-05
Ba-141	4.25E-07	2.91E-10	1.34E-08	0.00E+00	1.75E-10	1.77E-10	5.19E-06
Ba-142	1.84E-07	1.53E-10	9.06E-09	0.00E+00	8.81E-11	9.26E-11	7.59E-07
La-140	2.11E-08	8.32E-09	2.14E-09	0.00E+00	0.00E+00	0.00E+00	9.77E-05
La-142	1.10E-09	4.04E-10	9.67E-11	0.00E+00	0.00E+00	0.00E+00	6.86E-05
Ce-141	7.87E-08	4.80E-08	5.65E-09	0.00E+00	1.48E-08	0.00E+00	2.48E-05
Ce-143	1.48E-08	9.82E-06	1.12E-09	0.00E+00	2.86E-09	0.00E+00	5.73E-05
Ce-144	2.98E-06	1.22E-06	1.67E-07	0.00E+00	4.93E-07	0.00E+00	1.71E-04
Pr-143	8.13E-08	3.04E-08	4.03E-09	0.00E+00	1.13E-08	0.00E+00	4.29E-05
Pr-144	2.74E-10	1.06E-10	1.38E-11	0.00E+00	3.84E-11	0.00E+00	4.93E-06
Nd-147	5.53E-08	5.68E-08	3.48E-09	0.00E+00	2.19E-08	0.00E+00	3.60E-05
W-187	9.03E-07	6.28E-07	2.17E-07	0.00E+00	0.00E+00	0.00E+00	3.69E-05
Np-239	1.11E-08	9.93E-10	5.61E-10	0.00E+00	1.98E-09	0.00E+00	2.87E-05

References:

Dose Factors for Co-57, Zn-69m, Br-82, Nb-97, Sb-124, Sb-125 are from Reference 17, Table 4.
All others are from Reference 4, Table E-14.

NOTE: The tritium dose factor for bone is assumed to be equal to the total body dose factor. This assumes that tritium will act similarly in all organs (Reference 24).

Table 6.5 - BIOACCUMULATION FACTORS (B_f) FOR FRESHWATER FISH

Nuclide	B_f	Nuclide	B_f
H-3	9.0E-01	Tc-99m	1.5E+01
C-14	4.6E+03	Tc-101	1.5E+01
Na-24	1.0E+02	Ru-103	1.0E+01
P-32	1.0E+05	Ru-105	1.0E+01
Cr-51	2.0E+02	Ru-106	1.0E+01
Mn-54	4.0E+02	Ag-110m	1.0E+00
Mn-56	4.0E+02	Sb-124	1.0E+00
Fe-55	1.0E+02	Sb-125	1.0E+00
Fe-59	1.0E+02	Te-125m	4.0E+02
Co-57	5.0E+01	Te-127m	4.0E+02
Co-58	5.0E+01	Te-127	4.0E+02
Co-60	5.0E+01	Te-129m	4.0E+02
Ni-63	1.0E+02	Te-129	4.0E+02
Ni-65	1.0E+02	Te-131m	4.0E+02
Cu-64	5.0E+01	Te-131	4.0E+02
Zn-65	2.0E+03	Te-132	4.0E+02
Zn-69	2.0E+03	I-130	4.0E+01
Zn-69m	2.0E+03	I-131	4.0E+01
Br-82	4.2E+02	I-132	4.0E+01
Br-83	4.2E+02	I-133	4.0E+01
Br-84	4.2E+02	I-134	4.0E+01
Br-85	4.2E+02	I-135	4.0E+01
Rb-86	2.0E+03	Cs-134	1.9E+03
Rb-88	2.0E+03	Cs-136	1.9E+03
Rb-89	2.0E+03	Cs-137	1.9E+03
Sr-89	5.6E+01	Cs-138	1.9E+03
Sr-90	5.6E+01	Ba-139	4.0E+00
Sr-91	5.6E+01	Ba-140	4.0E+00
Sr-92	5.6E+01	Ba-141	4.0E+00
Y-90	2.5E+01	Ba-142	4.0E+00
Y-91m	2.5E+01	La-140	2.5E+01
Y-91	2.5E+01	La-142	2.5E+01
Y-92	2.5E+01	Ce-141	1.0E+00
Y-93	2.5E+01	Ce-143	1.0E+00
Zr-95	3.3E+00	Ce-144	1.0E+00
Zr-97	3.3E+00	Pr-143	2.5E+01
Nb-95	3.0E+04	Pr-144	2.5E+01
Nb-97	3.0E+04	Nd-147	2.5E+01
Mo-99	1.0E+01	W-187	1.2E+03
		Np-239	1.0E+01

References:

Bioaccumulation factors for Sb- nuclides are from Reference 16.
 Bioaccumulation factors for I-, Cs-, and Sr- nuclides are from Reference 21, Table 3.2.4.
 All other nuclides' bioaccumulation factors are from Reference 4, Table A-1.

Table 6.6 - EXTERNAL DOSE FACTORS FOR STANDING ON CONTAMINATED GROUND - DF_{ij}
(mrem/h per pCi/m²) (Page 1 of 2)

Nuclide	Total Body	Skin
H-3	0.0	0.0
C-14	0.0	0.0
Na-24	2.50E-08	2.90E-08
P-32	0.0	0.0
Cr-51	2.20E-10	2.60E-10
Mn-54	5.80E-09	6.80E-09
Mn-56	1.10E-08	1.30E-08
Fe-55	0.0	0.0
Fe-59	8.00E-09	9.40E-09
Co-57	1.77E-09	2.21E-09
Co-58	7.00E-09	8.20E-09
Co-60	1.70E-08	2.00E-08
Ni-63	0.0	0.0
Ni-65	3.70E-09	4.30E-09
Cu-64	1.50E-09	1.70E-09
Zn-65	4.00E-09	4.60E-09
Zn-69	0.0	0.0
Zn-69m	5.50E-09	6.59E-09
Br-82	3.18E-08	3.90E-08
Br-83	6.40E-11	9.30E-11
Br-84	1.20E-08	1.40E-08
Br-85	0.0	0.0
Rb-86	6.30E-10	7.20E-10
Rb-88	3.50E-09	4.00E-09
Rb-89	1.50E-08	1.80E-08
Sr-89	5.60E-13	6.50E-13
Sr-91	7.10E-09	8.30E-09
Sr-92	9.00E-09	1.00E-08
Y-90	2.20E-12	2.60E-12
Y-91m	3.80E-09	4.40E-09
Y-91	2.40E-11	2.70E-11
Y-92	1.60E-09	1.90E-09
Y-93	5.70E-10	7.80E-10
Zr-95	5.00E-09	5.80E-09
Zr-97	5.50E-09	6.40E-09
Nb-95	5.10E-09	6.00E-09
Nb-97	8.11E-09	1.00E-08
Mo-99	1.90E-09	2.20E-09
Tc-99m	9.60E-10	1.10E-09
Tc-101	2.70E-09	3.00E-09
Ru-103	3.60E-09	4.20E-09
Ru-105	4.50E-09	5.10E-09

Table 6.6 - EXTERNAL DOSE FACTORS FOR STANDING ON CONTAMINATED GROUND - DF_{ij}
(mrem/h per pCi/m²) (Page 2 of 2)

Nuclide	Total Body	Skin
Ru-106	1.50E-09	1.80E-09
Ag-110m	1.80E-08	2.10E-08
Sb-124	2.17E-08	2.57E-08
Sb-125	5.48E-09	6.80E-09
Te-125m	3.50E-11	4.80E-11
Te-127m	1.10E-12	1.30E-12
Te-127	1.00E-11	1.10E-11
Te-129m	7.70E-10	9.00E-10
Te-129	7.10E-10	8.40E-10
Te-131m	8.40E-09	9.90E-09
Te-131	2.20E-09	2.60E-06
Te-132	1.70E-09	2.00E-09
I-130	1.40E-08	1.70E-08
I-131	2.80E-09	3.40E-09
I-132	1.70E-08	2.00E-08
I-133	3.70E-09	4.50E-09
I-134	1.60E-08	1.90E-08
I-135	1.20E-08	1.40E-08
Cs-134	1.20E-08	1.40E-08
Cs-136	1.50E-08	1.70E-08
Cs-137	4.20E-09	4.90E-09
Cs-138	2.10E-08	2.40E-08
Ba-139	2.40E-09	2.70E-09
Ba-140	2.10E-09	2.40E-09
Ba-141	4.30E-09	4.90E-09
Ba-142	7.90E-09	9.00E-09
La-140	1.50E-08	1.70E-08
La-142	1.50E-08	1.80E-08
Ce-141	5.50E-10	6.20E-10
Ce-143	2.20E-09	2.50E-09
Ce-144	3.20E-10	3.70E-10
Pr-143	0.0	0.0
Pr-144	2.00E-10	2.30E-10
Nd-147	1.00E-09	1.20E-09
W-187	3.10E-09	3.60E-09
Np-239	9.50E-10	1.10E-09

References:

Dose Factors for Co-57, Zn-69m, Br-82, Nb-97, Sb-124 and Sb-125 are from Reference 18.
All others are from Reference 4, Table E-6.

Figure 6.1 - LIQUID EFFLUENT RELEASE POINTS

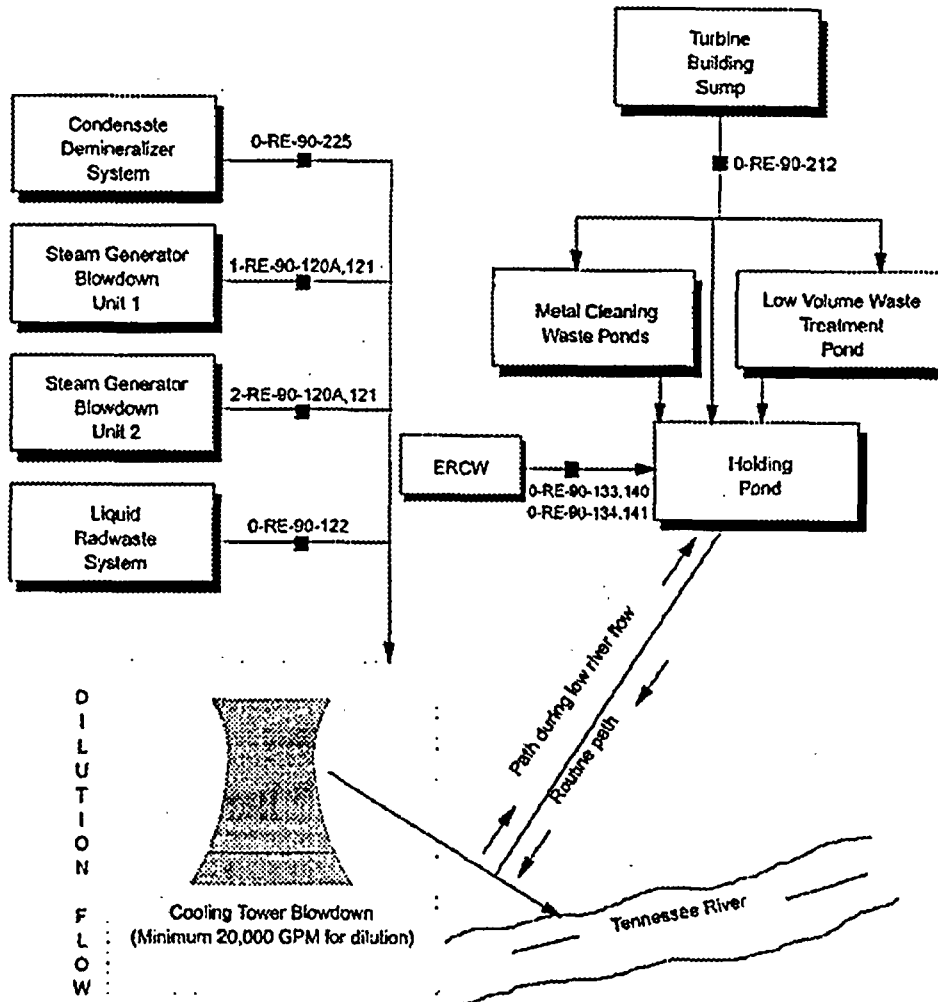

Figure 6.2 - LIQUID RADWASTE SYSTEM

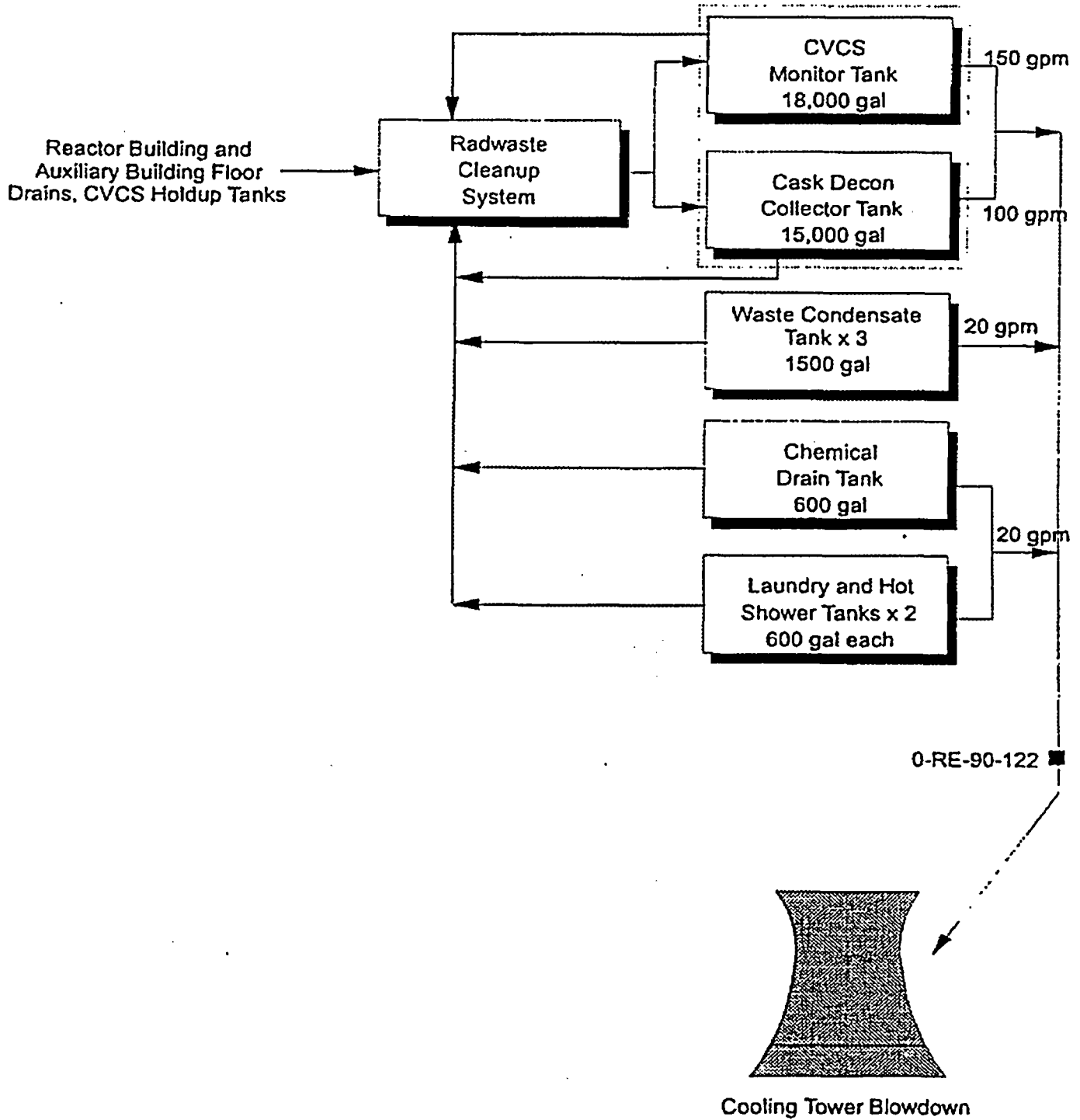
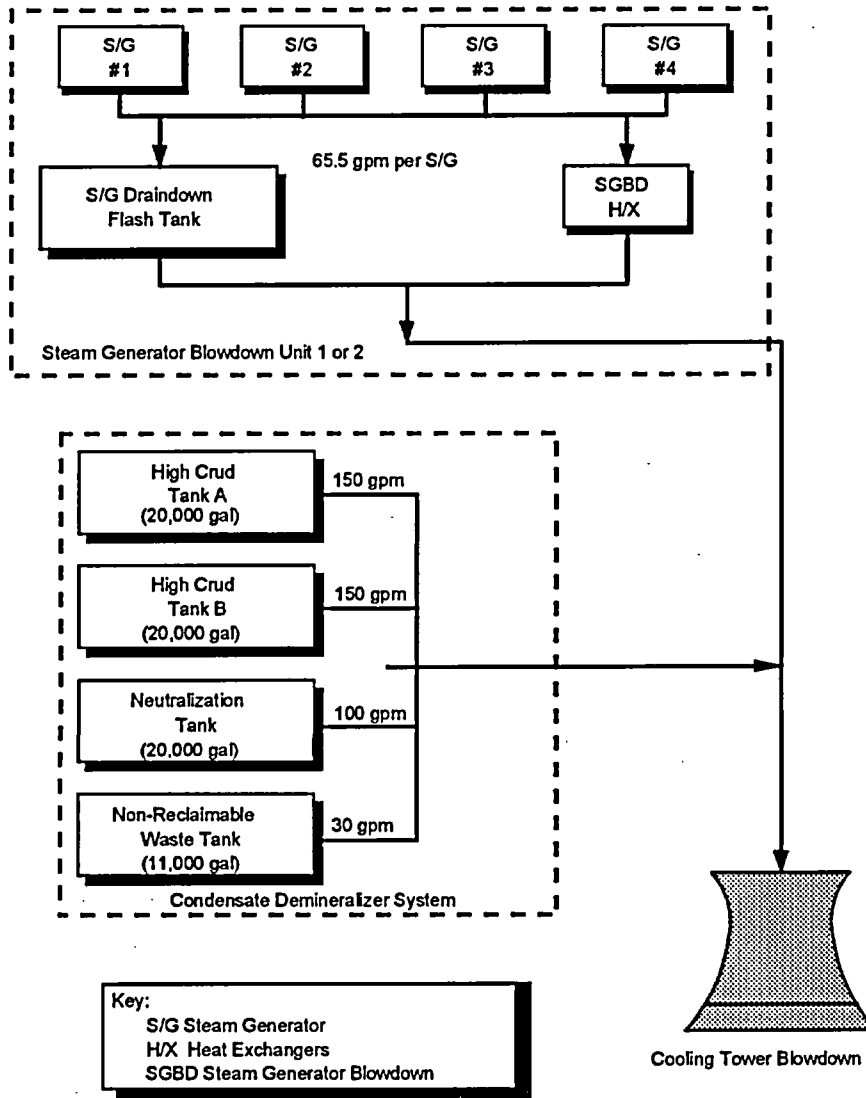

Figure 6.3 - STEAM GENERATOR BLOWDOWN/CONDENSATE DEMINERALIZER



7.0 - GASEOUS EFFLUENTS INTRODUCTION

There are six discharge points for gaseous radioactive effluents from WBN. These discharge points are: Unit 1 Condenser Vacuum Exhaust (CVE), Unit 2 CVE, Service Building Exhaust, Auxiliary Building Exhaust, Unit 1 Shield Building Exhaust, and Unit 2 Shield Building Exhaust. Detailed descriptions are provided below, and Figure 7.1 provides an outline of these airborne discharge points with associated radiation monitors. None of these discharge points meets the criteria of Regulatory Guide 1.111 for elevated releases; therefore, all releases are considered to be ground-level. Various plant systems contribute activity to the CVE, the Service Building Exhaust and the Auxiliary Building Exhaust, but these sources are not treated as individual release points. There are two gas systems associated with each Shield Building Exhaust: the Waste Gas Decay Tank (WGDT) System and the Containment Purge System which includes the Incore Instrument Room Purge.

The discharge points and the two associated gas systems are each monitored by noble gas radiation monitors. These monitors perform two main functions: to identify any unexpected radioactivity releases, and to ensure that the dose rate limits of ODCM Control 1.2.2.1 are met. Each monitor has an alarm/trip setpoint which causes the monitor to alarm if the monitor's setpoint is exceeded. The monitors do not have separate alarm and trip setpoints; they have one setpoint which performs both functions. The noble gas radiation monitors for Containment Purge and the WGDT release points initiate an isolation function if the alarm/trip setpoint is exceeded. The radiation monitor alarm/trip setpoints for each release point and discharge point are based on the radioactive noble gases in the gaseous effluent. It is not considered practical to apply instantaneous alarm/trip setpoints for integrating radiation monitors sensitive to radioiodines, radioactive materials in particulate form, and radionuclides other than noble gases.

Releases are continuous, except for releases from the WGDT or Containment Purge Systems which are made as batch releases.

For batch releases, the WGDT or Containment to be released is grab sampled for radioactivity in accordance with Table 2.2-2. The samples are analyzed to determine the maximum allowable release flow rate to ensure compliance with the dose rate limits of ODCM Control 1.2.2.1 as described in ODCM Section 7.2. The sampling results are also used to determine a setpoint for the associated noble gas radiation monitor for the release. The setpoints are determined in accordance with ODCM Section 7.1. Dose calculations are performed for each release, as outlined in ODCM Sections 7.3 and 7.4, to determine compliance with ODCM Controls 1.2.2.2 and 1.2.2.3.

For continuous releases, the pathways are sampled for radioactivity periodically, as required by Table 2.2-2. The samples are analyzed to ensure compliance with the dose and dose rate limits of ODCM Control 1.2.2.1, 1.2.2.2, and 1.2.2.3, as described in ODCM Sections 7.1 and 7.2. The sampling results are also used to determine a setpoint for the associated noble gas radiation monitor for the release. The setpoints are determined in accordance with ODCM Section 7.1. Dose calculations are performed for each sampling period, as outlined in ODCM Sections 7.3 and 7.4, to determine compliance with ODCM Controls 1.2.2.2 and 1.2.2.3.

Once per month, the projected dose is calculated, as outlined in ODCM Section 7.5, to determine compliance with ODCM Control 1.2.2.4.

All dose calculations performed to determine compliance with ODCM Controls 1.2.2.2, 1.2.2.3 and 1.2.2.4 are detailed in ODCM Sections 7.3 and 7.4. The calculational methodologies are based on the guidance provided in NUREG-0133 and Regulatory Guide 1.109. Because all releases are ground level, semi-infinite cloud models are used in the dose calculations.

The quantities of each radionuclide identified and released are input into a more rigorous calculation methodology, described in ODCM Section 7.7, to determine the individual and population doses to be reported to the NRC in the Annual Radioactive Effluent Release Report. These dose calculation methodologies are based on the guidance provided in Regulatory Guide 1.109.

RELEASE/DISCHARGE POINTS DESCRIPTION

There are six discharge points at WBN that are monitored for airborne radioactive effluents. These are: a CVE for each unit, a Service Building Exhaust, an Auxiliary Building Exhaust and a Shield Building Exhaust for each unit. Each of these discharge points may have one or more release points associated with it as described below. Figure 7.1 provides a simplified outline of the airborne effluent release and discharge points with associated radiation monitor identifications. Figure 7.2 provides a more detailed description of the release and discharge points, with flow rates, radiation monitors, and associated inputs.

Condenser Vacuum Exhaust

The CVEs are located in the turbine building. They exhaust at a maximum design flow rate of 45 cfm per pump. These discharge points are monitored by radiation monitors 1,2-RE-90-119 for normal operation.

Service Building Exhaust

Areas in the Service Building in which work is conducted which may produce radioactive effluents all exhaust to the Service Building Exhaust. This discharge point exhausts at a maximum design flow rate of approximately 10,000 cfm and is monitored by radiation monitor 0-RE-90-132B.

Auxiliary Building Exhaust

The Auxiliary Building exhausts at a maximum total design flow of 228,000 cfm (2 of 4 ventilation fans and 1 fuel handling fan). This discharge point exhaust is monitored by radiation monitor 0-RE-90-101B. The annulus vacuum priming fans (2 fans at 1000 cfm each) exhaust to the auxiliary building fuel handling exhaust header.

Shield Building Exhaust

There is one Shield Building Exhaust for each unit. These discharge points are monitored by radiation monitors 1,2-RE-90-400A.

There are nine Waste Gas Decay Tanks (WGDTs) that discharge into the waste gas header which is released into the Unit 1 Shield Building Vent (see Figure 7.3). The Train A Auxiliary Building Gas Treatment System (ABGTS) is operated during a WGDT release. Each WGDT has a design capacity of 600 ft³ and a maximum design release rate of 100 cfm [SOURCE NOTE 17]. The WGDT release point is monitored by radiation monitor 0-RE-90-118.

The Auxiliary Building Gas Treatment System (ABGTS) draws from the Auxiliary Building Secondary Containment Enclosure and exhausts to the Shield Building Exhaust. Any activity released from the Auxiliary Building through the ABGTS is accounted for as a part of the Auxiliary Building Exhaust releases, and will not be tracked separately. An Auxiliary Building Isolation signal starts the ABGTS. The Emergency Gas Treatment System is used to draw a vacuum in the annulus and exhaust to the Shield Building Exhaust under emergency conditions, and could do so during normal operation.

Both the Containment Purge and the Incore Instrument Room Purge from each unit tie into the Shield Building Exhaust. The Containment Purge release point exhausts at a maximum of 28,000 cfm and is monitored by radiation monitors 1,2-RE-90-130 and 1,2-RE-90-131. If the Incore Instrument Room Purge is operating exclusively, it exhausts at 800 cfm, and is monitored by the Containment Purge Monitors given above. The common header exhausts to the Shield Building Exhaust.

7.1 GASEOUS EFFLUENT MONITOR INSTRUMENT SETPOINTS

Airborne effluent noble gas monitor setpoints are determined to ensure that the dose rate at the UNRESTRICTED AREA BOUNDARY does not exceed the dose rate limits given in ODCM Control 1.2.2.1 and to identify unexpected releases. ODCM Control 1.1.2 establishes operability requirements for these monitors. Allocation factors (AF) are used in the setpoint calculation to allocate a fraction of the total body dose rate limit to each discharge point. These allocation factors may be changed as required to support plant operational needs, but shall not exceed a sum of one. Therefore, a particular monitor reaching the calculated maximum setpoint as described below does not necessarily mean that the dose rate limit at the UNRESTRICTED AREA BOUNDARY is being exceeded; the alarm indicates that the specific release/discharge point is contributing a greater fraction of the dose rate limit than was allocated to the associated monitor and will require further evaluation.

The gaseous effluent radiation monitors and their setpoint information are outlined below:

Pathway	Monitor	Default Setpoint	Setpoint Limit	Release Setpoint
Containment Purge	1-RE-90-130 2-RE-90-130 1-RE-90-131 2-RE-90-131	Section 7.1.1.1	(1)	Section 7.1.2
WGDT	0-RE-90-118	Section 7.1.1.2	S_{max}	Section 7.1.2
Shield Building Exhaust	1-RE-90-400A 2-RE-90-400A	Section 7.1.1.3	S_{max}	Section 7.1.2
Auxiliary Building Exhaust	0-RE-90-101B	Section 7.1.1.3	S_{max}	Section 7.1.2
Service Building Exhaust	0-RE-90-132B	Section 7.1.1.3	S_{max}	Section 7.1.2
CVE	1-RE-90-119 2-RE-90-119	Section 7.1.1.4	S_{max}	Section 7.1.2

(1) S_{max} or Tech Spec value from setpoint and scaling document, whichever is smaller.

7.1.1 Default Monitor Setpoints

7.1.1.1 Section Deleted

7.1.1.2 Waste Gas Decay Tank Effluent Monitor (0-RE-90-118)

During periods of release, the methodology in Section 7.1.2 will be used to determine the monitor setpoint.

7.1.1.3 Shield Building Exhaust (1,2-RE-90-400A), Auxiliary Building Exhaust(0-RE-90-101B), Containment Purge Effluent Monitors (1,2-RE-90-130,-131), and Service Building Exhaust (0-RE-90-132B)

These discharge point effluent monitors are set to ensure compliance with ODCM Control 1.2.2.1. The default setpoints are determined by calculating the maximum calculated setpoint described by Equation 7.3 using Xe-133 monitor efficiencies, design flow rates, and setting the ratio DR_{lim}/DR equal to 1.0. The default setpoints for the shield building monitors are calculated in units of $\mu\text{Ci/s}$. The default setpoints will be defined in plant procedures.

7.1.1.4 Condenser Vacuum Exhaust Vent (1,2-RE-90-119)

This discharge point effluent monitor is set to ensure compliance with ODCM Control 1.2.2.1 and to identify the presence of primary to secondary leakage of radioactivity. The default setpoint is determined in one of two ways: by calculating the maximum calculated setpoint as described in Section 7.1.1.3, and then taking a percentage of this value as the setpoint; or by defining the setpoint as two times the normal background. The default setpoint will be defined in plant instructions. Once a primary to secondary leak is identified, the setpoint on this monitor may be incrementally adjusted upward as defined in plant procedures to enable it to be used to identify any further increases in the leak rate.

7.1.2 Release Permit Monitor Setpoint Determination

For each release, two setpoints are calculated for the monitor: one based on the expected response of the monitor to the radioactivity in the effluent stream (described in Sections 7.1.2.1 and 7.1.2.2) which allows for the identification of any release of radioactivity above the expected amount; and a calculated maximum setpoint which corresponds to the most restrictive dose rate limit given in ODCM Control 1.2.2.1 (described in Section 7.1.2.3) which ensures that the release will be stopped if it exceeds the dose rate limits after dilution. A comparison is then made (as described in Section 7.1.2.4) between these two calculated setpoints and the default setpoints (described in Section 7.1.1) to determine which is used for the release.

7.1.2.1 Expected Monitor Response

The expected monitor response, ER, is determined using the following equation:

$$ER = BKG + \sum_i E_i C_i \quad (7.1)$$

where:

BKG = monitor background, cpm.

E_i = efficiency factor for the monitor for nuclide i , cpm per $\mu\text{Ci/cc}$. This term may also be referred to as a response or calibration factor.

C_i = measured concentration of nuclide i , $\mu\text{Ci/cc}$.

7.1.2.2 Expected Response Setpoint

An expected response setpoint S_{ER} is calculated for the monitor for each release:

$$S_{ER} = X \sum_i E_i C_i + X BKG \quad (7.2)$$

where:

X = administrative factors designed to account for expected variations in monitor response and background (as defined in plant procedures). The ranges of values are: $0 < X \leq 2.0$.
[SOURCE NOTE 15]

7.1.2.3 Calculated Maximum Setpoint

The calculated maximum setpoint, S_{max} in cpm, corresponding to the dose rate limit is determined using the following equation:

$$S_{max} = \left\{ AF \ VCF \ SF \left[\frac{DR_{Lim}}{DR} (ER - BKG) \right] \right\} + BKG \quad (7.3)$$

where:

AF = dose rate allocation factor for the release point, dimensionless. The sum of all dose rate allocation factors must be ≤ 1 . The dose rate allocation factors for release points are defined in approved plant procedures.

VCF = Vacuum correction factor applied to noble gas monitors whose detector operates at a negative pressure. This factor will be defined in plant procedures for applicable monitors and will have a range of: $0 < VCF \leq 1.0$. [SOURCE NOTE 2]

SF = safety factor for the monitor, dimensionless. Safety factors will be ≤ 1 . Safety factors for each monitor are defined in approved plant procedures.

DR_{Lim} = the dose rate limit, mrem/y.

= 500 mrem/y to the total body for noble gases,

= 3000 mrem/y to the skin for noble gases, and

DR = the calculated dose rate for the release, mrem/y.

= DR_{TB} for total body (as described in Section 7.2.1),

= DR_s for skin (as described in Section 7.2.2), and

ER = expected monitor response (as calculated in Equation 7.1), cpm.

BKG = the monitor background, cpm.

7.2 GASEOUS EFFLUENTS - DOSE RATES

Dose rates are calculated for total body and skin due to submersion within a cloud of noble gases using a semi-infinite cloud model as described in NUREG-0133. The dose rates are compared to their respective limits and are used in the determination of setpoints for noble gas radiation monitors.

7.2.1 Total Body Dose Rate

The calculated total body dose rate must meet the condition (from NUREG-0133 Section 5.2.1):

$$\sum_I \left[V_i Q_{iV} + DFB_i \left\{ \left(\frac{z}{\sigma} \right)_V Q_{iV} \right\} \right] \leq 500 \text{ mrem/y}$$

Since there are no elevated release points at WBN, the elevated release terms in the equation (V_i and Q_{iV}) are not used. Substituting the flow (f) multiplied by the concentration (C) for the release rate (Q) in the above equation, the dose rate to the total body, DR_{TB} in mrem/y, is calculated using the following equation:

$$DR_{TB} = \frac{z}{\sigma} f \sum_I C_i DFB_i \quad (7.4)$$

where:

z/σ = terrain adjusted relative concentration, s/m^3 . Relative air concentrations are calculated for the unrestricted area boundary in each of the 16 sectors as described in Section 7.9.2 using the historical meteorological data for the period 1974-93 given in Table 7.2. For dose rate calculations, the highest value from the 16 unrestricted area boundary locations is used. The values for each of the sixteen sectors are given in Table 7.3 (maximum values are highlighted on the table).

f = flowrate of effluent stream, cc/s.

C_i = concentration of noble gas nuclide i in effluent stream, $\mu\text{Ci/cc}$.

DFB_i = total body dose factor due to gamma radiation for noble gas nuclide i , mrem/y per $\mu\text{Ci/m}^3$ (Table 7.4).

The total body dose rate is calculated for each release. It is compared to the limit of 500 mrem/y and is also used in the determination of the radiation monitor setpoint as described in Section 7.1.2.

7.2.2 Skin Dose Rate

The calculated skin dose rate must meet the condition (from NUREG-0133 Section 5.2.1):

$$\sum_i \left\{ \left[\left(DFS_i \left(\frac{x}{Q} \right)_s + 1.1 B_i \right) Q_{is} \right] + \left[DFS_i + 1.1 DF_{\gamma i} \right] \left[\left(\frac{x}{Q} \right)_s Q_{iv} \right] \right\} \leq 3000 \text{ mrem/y}$$

Since there are no elevated release points at WBN, the stack terms in the equation, DFS_i , $(x/Q)_s$, B_i , and Q_{is} , are not used. Substituting the flow (f) multiplied by the concentration (C) for the release rate (Q) in the above equation, the dose rate to the skin, DR_s in mrem/y, is calculated using the following equation:

$$DR_s = \frac{x}{Q} f \sum_i C_i (DFS_i + 1.1 DF_{\gamma i}) \quad (7.5)$$

where:

x/Q = terrain adjusted relative concentration, s/m^3 . Relative air concentrations are calculated for the unrestricted area boundary in each of the 16 sectors as described in Section 7.9.2 using the historical meteorological data for the period 1974-93 given in Table 7.2. For dose rate calculations, the highest value from the 16 unrestricted area boundary locations is used. The values for each of the sixteen sectors are given in Table 7.3 (maximum values are highlighted on the table).

f = flowrate of effluent stream, cc/s.

C_i = concentration of noble gas nuclide i in effluent stream, $\mu\text{Ci/cc}$.

DFS_i = skin dose factor due to beta radiation for noble gas nuclide i , mrem/y per $\mu\text{Ci/m}^3$ (Table 7.4).

1.11 = the average ratio of tissue to air energy absorption coefficients, mrem/mrad.

$DF_{\gamma i}$ = dose conversion factor for external gamma for noble gas nuclide i , mrad/y per $\mu\text{Ci/m}^3$ (Table 7.4).

The skin dose rate is calculated for each release. It is compared to the limit of 3000 mrem/y and is also used in the determination of the radiation monitor setpoint as described in Section 7.1.2.

7.2.3 I-131, I-133, Tritium and All Radionuclides in Particulate Form with Half-Lives of Greater Than 8 Days - Organ Dose Rate

Organ dose rates due to I-131, I-133, tritium and all radionuclides in particulate form with half-lives of greater than 8 days, DR_j in mrem/y, are calculated for all age groups (adult, teen, child, and infant) and all organs (bone, liver, total body, thyroid, kidney, lung, and GI Tract). The calculated organ dose rate must meet the condition (from NUREG-0133 Section 5.2.1):

$$\sum_i P_i (W_i Q_i + W_v Q_{iv}) \leq 1500 \text{ mrem/y}$$

Since there are no elevated release points at WBN, the elevated release terms (W_i and Q_i) are not used. Substituting the flow (f) multiplied by the concentration (C) for the release rate (Q) in the above equation, and inserting the appropriate dispersion factor (χ/Q or D/Q) for each pathway considered, the organ dose rate, DR_j in mrem/y, is calculated using the following equation:

$$DR_j = f \left\{ C_T \frac{\chi}{Q} (R_{IT} + R_{CTP}) + \sum_i C_i \left[\frac{\chi}{Q} R_{ii} + \frac{D}{Q} (R_{CPI} + R_{GI}) \right] \right\} \quad (7.6)$$

where:

- f = flowrate of effluent stream, cc/s.
- C_T = concentration of tritium in effluent stream, $\mu\text{Ci/cc}$.
- χ/Q = terrain adjusted relative concentration, s/m^3 . Relative air concentrations are calculated for the unrestricted area boundary in each of the 16 sectors as described in Section 7.9.2 using the historical meteorological data for the period 1974-93 given in Table 7.2. For dose rate calculations, the highest value from the 16 unrestricted area boundary locations is used. The values for each of the sixteen sectors are given in Table 7.3 (maximum values are highlighted on the table).
- R_{IT} = inhalation dose factor for tritium, mrem/y per $\mu\text{Ci/m}^3$. Dose factor is calculated as described in Section 7.8.13.
- R_{CTP} = Grass-cow-milk dose factor for tritium, mrem/y per $\mu\text{Ci/m}^3$. Dose factor is calculated as described in Section 7.8.7.
- C_i = concentration of nuclide i in effluent stream, $\mu\text{Ci/cc}$.
- R_{ii} = inhalation dose factor for each identified nuclide i , mrem/y per $\mu\text{Ci/m}^3$. Dose factors are calculated as described in Section 7.8.13.
- D/Q = terrain adjusted relative deposition, $1/\text{m}^2$. Relative deposition is calculated for the unrestricted area boundary in each of the 16 sectors as described in Section 7.9.3 using the historical meteorological data for the period 1974-93 given in Table 7.2. For dose rate calculations, the highest value from the 16 unrestricted area boundary locations is used. The values for each of the sixteen sectors are given in Table 7.3 (maximum values are highlighted on the table).
- R_{CPI} = Grass-cow-milk dose factor for each identified nuclide i , $\text{m}^2\text{-mrem/y per } \mu\text{Ci/s}$. Dose factors are calculated as described in Section 7.8.1.
- R_{Gi} = ground plane dose factor for each identified nuclide i , $\text{m}^2\text{-mrem/y per } \mu\text{Ci/s}$. Dose factors are calculated as described in Section 7.8.14.

The maximum organ dose rate is selected from among the dose rates calculated for all the organs and all age groups. It is compared to the limit of 1500 mrem/y.

7.3 DOSE - NOBLE GASES

Doses are calculated for gamma and beta air doses due to exposure to a semi-infinite cloud of noble gases. These doses will be calculated at the unrestricted area boundary location with the highest terrain adjusted annual-average χ/Q based on 1974-93 meteorological data (Table 7.2). This location is chosen from the UNRESTRICTED AREA BOUNDARY locations listed in Table 7.1. Dispersion factors are calculated using the methodology described in Section 7.9.2.

No credit is taken for radioactive decay.

7.3.1 Gamma Dose to Air

NUREG-0133 Section 5.3.1 provides the following equation for the calculation of the gamma air dose from noble gases:

$$D = k \sum_i \left[M_i \left(\frac{\chi}{Q} \right)_v Q_{iv} + \left(\frac{\chi}{Q} \right)_v q_{iv} \right] + [b_1 Q_{is} + b_2 q_{is}]$$

Because there are no elevated release points, the terms subscripted s in the equation are not used. Since all releases are considered to be long-term, the terms using lower case variables are not used. Since WBN will be calculating a dose for each release made, the total release (Q) in the above equation is replaced by the release rate (Q) multiplied by the length of the release (T). The gamma air dose, D_γ in mrad, is calculated for each release using the following equation:

$$D_\gamma = 1.9E-06 \frac{\chi}{Q} \sum_i Q_i DF_{\gamma i} T \quad (7.7)$$

where:

1.9E-06 = conversion factor, y/min.

χ/Q = highest terrain adjusted unrestricted area boundary annual-average relative concentration, s/m³ (from Table 7.3).

Q_i = release rate for nuclide i, $\mu\text{Ci/s}$.

$DF_{\gamma i}$ = dose conversion factor for external gamma for nuclide i (Table 7.4), mrad/y per $\mu\text{Ci/m}^3$.

T = duration of release, min.

The gamma air dose calculated by this method will be used in the cumulative dose calculations discussed in Section 7.3.3.

7.3.2 Beta Dose to Air

NUREG-0133 Section 5.3.1 provides the following equation for the calculation of the beta air dose from noble gases:

$$D = k \sum_i \left\{ N_i \left[\left(\frac{x}{Q} \right)_v Q_{iv} + \left(\frac{x}{Q} \right)_v q_{iv} \right] + \left[\left(\frac{x}{Q} \right)_s Q_{is} + \left(\frac{x}{Q} \right)_s q_{is} \right] \right\}$$

Because there are no elevated release points, the terms subscripted s in the equation are not used. Since all releases are considered to be long-term, the terms using lower case variables are not used. Since WBN will be calculating a dose for each release made, the total release (Q) in the above equation is replaced by the release rate (Q) multiplied by the length of the release (T). The beta air dose, D_β in mrad, is calculated for each release using the following equation:

$$D_\beta = 1.9E-06 \frac{x}{Q} \sum_i Q_i DF_{\beta i} T \quad (7.8)$$

where:

1.9E-06 = conversion factor, y/min.

x/Q = highest terrain adjusted unrestricted area boundary annual-average relative concentration, s/m^3 (from Table 7.3).

Q_i = release rate for nuclide i, $\mu Ci/s$.

$DF_{\beta i}$ = dose conversion factor for external beta for nuclide i, mrad/y per $\mu Ci/m^3$ (from Table 7.4).

T = duration of release, min.

The beta air dose calculated by this method will be used in the cumulative dose calculations discussed in Section 7.3.3.

7.3.3 Cumulative Dose - Noble Gas

Quarterly and annual sums of all doses are calculated for each release as described below to compare to the limits listed in ODCM Control 1.2.2.2.

For noble gases, cumulative doses are calculated for gamma and beta air doses. Doses due to each release are summed with the doses for all previous releases in the current quarter or year to obtain cumulative quarterly and annual doses.

7.3.4 Comparison to Limits

The cumulative calendar quarter and calendar year doses are compared to their respective limits in accordance with Surveillance Requirement 2.2.2.2. to determine compliance.

7.4 DOSE DUE TO I-131, I-133, TRITIUM AND ALL RADIONUCLIDES IN PARTICULATE FORM WITH HALF-LIVES OF GREATER THAN 8 DAYS

7.4.1 Organ Dose Calculation

Organ doses due to I-131, I-133, tritium and all radionuclides in particulate form with half-lives of greater than 8 days are calculated for each release for the critical receptor. The critical receptor is defined as the unrestricted area boundary in the sector with the highest annual average terrain adjusted χ/Q . The annual average χ/Q and D/Q are calculated using the methodology in Sections 7.9.2 and 7.9.3 using the historical 1974-93 meteorological data (Table 7.2). A conservative assumption is used to select the dispersion factors for the critical receptor. The highest calculated χ/Q and D/Q values are chosen from Table 7.1 values after being multiplied by the applicable terrain adjustment factors (from Table 7.3), and may not be for the same compass sector. Pathways considered to exist at this location are inhalation, ground plane exposure, grass-cow-milk ingestion, grass-cow-beef ingestion and fresh leafy and stored vegetable ingestion. All age groups are considered (adult, teen, child and infant). Dose factors for these age groups and pathways are calculated as described in Section 7.8. For the ground exposure pathway, which has no age or organ specific dose factors, the total body dose will be added to the internal organ doses for all age groups. No credit is taken for radioactive decay.

NUREG-0133 Section 5.3.1 provides the following equation for the calculation of the organ dose from radioiodines, radioactive materials in particulate form with half-lives greater than 8 days:

$$D = k \sum_i R_i (W_s Q_{is} + w_s q_{is} + W_v Q_{iv} + w_v q_{iv})$$

Because there are no elevated release points, the terms subscripted s in the equation are not used. Since all releases are considered to be long-term, the terms using lower case variables are not used. Since WBN will be calculating a dose for each release made, the total release (Q) in the above equation is replaced by the release rate (Q) times the length of the release (T). The general equation for the calculation of organ dose is:

$$D_i = 3.17E-08 T \sum_i \sum_P R_{Pi} (W_P Q_i) \quad (7.9)$$

where:

3.17E-08 = conversion factor, y/s

T = duration of release, s.

R_{Pi} = dose factor for pathway P for each identified nuclide i, $m^2\text{-mrem/y}$ per $\mu\text{Ci/s}$ for ground plane, grass-milk animal-milk, grass-cow-beef, and vegetation pathways, and $m\text{rem/y}$ per $\mu\text{Ci/m}^3$ for inhalation and tritium ingestion pathways. Equations for calculating these dose factors are given in Section 7.8.

W_P = dispersion factor for the location and pathway P (from Table 7.3),
= terrain adjusted χ/Q for the inhalation and tritium ingestion pathways,
= terrain adjusted D/Q for the food and ground plane pathways,

Q_i = release rate for radionuclide i, $\mu\text{Ci/s}$.

From the four age groups considered, the maximum is determined by comparing all organ doses for all age groups. The age group with the highest single organ dose is selected as the critical age group. The organ doses for the critical age group will be used in the cumulative doses discussed in Section 7.4.2.

7.4.2 Cumulative Organ Doses

Quarterly and annual sums of all doses are calculated for each release as described below to compare to the limits listed in ODCM Control 1.2.2.3.

For maximum organ dose, cumulative quarterly and annual doses are maintained for each of the eight organs considered. The cumulative dose is obtained by summing the doses for each organ of the critical age group (as calculated in Section 7.4.1) as determined for each release with the organ doses for all previous releases in the quarter or year to obtain the cumulative quarterly and annual doses. Thus, the cumulative organ doses will be conservative values, consisting of doses belonging to various age groups depending on the mix of radionuclides. The highest of these cumulative organ doses is used for the comparison to the limits described in ODCM Control 1.2.2.3.

7.4.3 Comparison to Limits

The cumulative calendar quarter and calendar year doses are compared to their respective limits in accordance with ODCM Surveillance Requirement 2.2.2.3 to determine compliance.

7.5 DOSE PROJECTIONS

In accordance with ODCM Surveillance Requirement 2.2.2.4.1, dose projections will be performed. This will be done for the gamma dose, the beta dose and the maximum organ dose.

$$D = \left\{ \frac{(a+b)}{d} \times 31 \right\} + c \quad (7.10)$$

where:

- D = the 31-day dose projection, mrem.
- a = the cumulative dose for the quarter, mrem.
- b = the projected dose for this release (as calculated in Sections 7.4.1, 7.4.2 and 7.4.3), mrem.
- c = any anticipated additional dose in the next month from other sources, mrem.
- d = current number of days into the quarter up to the time of the release under consideration.

The 31-day projected dose will be compared to the limits given in ODCM Control 1.2.2.4 in accordance with Surveillance Requirement 2.2.2.4.1 to determine compliance.

7.6 GASEOUS RADWASTE TREATMENT SYSTEM DESCRIPTION

The GASEOUS RADWASTE TREATMENT SYSTEM (GRTS) described in the WBN FSAR shall be maintained and operated to keep releases ALARA. A simplified flow diagram for the GRTS is given in Figure 7.3.

7.7 DOSE CALCULATIONS FOR REPORTING

A complete dose analysis utilizing the total estimated gaseous releases for each calendar quarter will be performed and reported as required in ODCM Administrative Control 5.2. All real pathways and receptor locations identified by the most recent land use survey are considered. In addition, actual meteorological data representative of a ground level release for each corresponding calendar quarter will be used. For iodine releases, it is assumed that half the iodine released is in organic form. Organic iodine causes a dose only by inhalation. For cow-milk and beef ingestion doses, the fraction of the time the animals are on stored feed (identified in the survey) is used in the calculation.

7.7.1 Noble Gas - Gamma and Beta Air Dose

Regulatory Guide 1.109 Equation B-5 provides the following equation for the calculation of gamma and beta air doses from noble gas releases:

$$D = \sum_i Q_i \chi_{im} (DF_{\gamma i} \text{ or } DF_{\beta i}) \quad (7.11)$$

where:

χ_{im} = concentration of nuclide i at location m , $\mu\text{Ci}/\text{m}^3$. Air concentrations are calculated as described by Equation 7.33.

$DF_{\gamma i}$ = dose conversion factor for external gamma for nuclide i , mrad/y per $\mu\text{Ci}/\text{m}^3$ (Table 7.4).

$DF_{\beta i}$ = dose conversion factor for external beta for nuclide i , mrad/y per $\mu\text{Ci}/\text{m}^3$ (Table 7.4).

7.7.2 Noble Gas - Air Submersion Dose

Regulatory Guide 1.109 Equation B-8 provides the following equation for the calculation of the total body submersion dose from noble gas releases:

$$D = SF \sum_i \chi_{im} DFB_i \quad (7.12)$$

where:

SF = shielding factor. This factor is conservatively set equal to 1.0.

χ_{im} = concentration of nuclide i at location m , $\mu\text{Ci}/\text{m}^3$. Air concentrations are calculated as described by Equation 7.33.

DFB_i = total body dose conversion factor due to submersion in a semi-infinite cloud of noble gases for nuclide i , mrem/y per $\mu\text{Ci}/\text{m}^3$ (Table 7.4).

Regulatory Guide 1.109 Equation B-9 provides the following equation for the calculation of the skin submersion dose from noble gas releases:

$$D = \left\{ 1.11 SF \sum_i \chi_{im} DF_{\gamma i} \right\} + \sum_i \chi_{im} DFS_i \quad (7.13)$$

where:

1.11 = the average ratio of tissue to air energy absorption coefficients, mrem/mrad .

SF = shielding factor. This factor is conservatively set equal to 1.0.

χ_{im} = concentration of nuclide i at location m , $\mu\text{Ci}/\text{m}^3$. Air concentrations are calculated as described by Equation 7.33.

$DF_{\gamma i}$ = dose conversion factor for external gamma for nuclide i , mrad/y per $\mu\text{Ci}/\text{m}^3$ (Table 7.4).

DFS_i = skin dose conversion factor due to submersion in a semi-infinite cloud of noble gases for nuclide i , mrem/y per $\mu\text{Ci}/\text{m}^3$ (Table 7.4).

7.7.3 Radioiodine, Particulate, and Tritium - Maximum Organ Dose

Regulatory Guide 1.109 Equations B-12, -13, and -14 provides the following equation for the calculation of doses from the release of iodine and particulate radionuclides:

$$D = S_F \sum_i C_{Gi} R_{Gi} \quad (\text{for ground contamination})$$

$$D = BR_a \sum_i \chi_i R_{Pi} \quad (\text{for inhalation})$$

$$D = \sum_i R_{Pi} (U_{va} f_g C_{iv} + U_{ma} C_{im} + U_{Fa} C_{Fi} + U_{La} f_L C_{Li}) \quad (\text{for ingestion})$$

These three equations are combined into one equation for this presentation by dropping the subscripts on the dose factors, and substituting the appropriate dispersion factor (D/Q or χ/Q) multiplied by the total release (Q) for the concentration terms (C) as follows:

$$D = BR_a \sum_i \frac{\chi}{Q} Q_i R_{Pi} + S_F \sum_i \frac{D}{Q} Q_i R_{Gi} + \sum_i R_{Pi} \frac{D}{Q} Q_i (U_{va} f_g + U_{ma} + U_{Fa} + U_{La} f_L)$$

The shielding factor (S_F) is conservatively set equal to 1.0, therefore, that term drops out of the equation. The vegetable fractions (f), ingestion rates (U) and breathing rate (BR) are included in the calculation of the dose factors, given in ODCM Sections 7.8.1 through 7.8.14, therefore, they may also be dropped from this equation. The equation then becomes:

$$D = \sum_i \frac{\chi}{Q} Q_i R_{Pi} + \sum_i \frac{D}{Q} Q_i R_{Gi} + \sum_i \frac{D}{Q} Q_i R_{Pi}$$

Since the calculation of tritium concentration in vegetation is based on air concentration rather than ground deposition (Equation C-9 in Regulatory Guide 1.109), a separate term is added to the equation to account for the tritium ingestion dose pathways. In addition, a terrain adjustment factor (TAF) is added. Therefore the equation for calculating the organ dose, D_j in mrem, is:

$$D_j = 3.17E-08 \left\{ \left(\frac{\chi}{Q} \right) (TAF) \sum_P R_{PT} Q_T + \sum_i \left[\left(\frac{D}{Q} \right) (TAF) \sum_P R_{Pi} + \left(\frac{D}{Q} \right) (TAF) R_{Gi} + \left(\frac{\chi}{Q} \right) (TAF) R_{Pi} \right] Q_i \right\} \quad (7.14)$$

where:

3.17E-08 = conversion factor, y/s.

D/Q = Relative deposition for location under consideration, m^{-2} . Relative deposition is calculated as described in Equation 7.35.

R_{PT} = ingestion dose factor for pathway P for tritium, $m^2\text{-mrem/y}$ per $\mu\text{Ci/s}$. Ingestion pathways available for consideration are the same as those listed above for R_{Pi} . Equations for calculating ingestion dose factors for tritium are given in Sections 7.8.7 through 7.8.12.

Q_T = adjusted release rate for tritium for location under consideration, $\mu\text{Ci/s}$. The initial release rate is adjusted to account for decay between the release point and the location, depending on the frequency of wind speeds applicable to that sector. Hence, the adjusted release rate is equal to the actual release rate decayed for an average travel time during the period.

$$Q_T = \sum_{k=1}^n f_k \exp\left(-\lambda_i \frac{x}{u_j}\right) \quad (7.15)$$

where:

Q_T = initial average release rate for tritium over the period, $\mu\text{Ci/s}$.

f_k = joint relative frequency of occurrence of winds in windspeed class k blowing toward this exposure point, expressed as a fraction.

λ_i = radiological decay constant for nuclide i, s^{-1} .

x = downwind distance, m.

u_j = midpoint value of wind speed class interval k, m/s.

- R_{pi} = ingestion dose factor for pathway P for each identified nuclide i (except tritium), m²-mrem/y per μ Ci/s. Ingestion pathways available for consideration include:
 pasture grass-milk animal-milk ingestion - R_{CP} (see Section 7.8.1).
 stored feed-milk animal-milk ingestion - R_{CS} (see Section 7.8.2).
 pasture grass-beef ingestion - R_{MP} (see Section 7.8.3).
 stored feed-beef ingestion - R_{MS} (see Section 7.8.4).
 fresh leafy vegetable ingestion - R_{VF} (see Section 7.8.5).
 stored vegetable ingestion - R_{VS} (see Section 7.8.6).
- R_{Gi} = Dose factor for standing on contaminated ground, m²-mrem/y per μ Ci/s. The equation for calculating the ground plane dose factor is given in Section 7.8.14.
- λ/Q = Relative concentration for location under consideration, s/m³. Relative concentrations are calculated as described by Equation 7.34.
- R_{Ii} = Inhalation dose factor, mrem/y per μ Ci/m³. The equation for calculating the inhalation dose factor is given in Section 7.8.13.
- Q_i = adjusted release rate for nuclide i for location under consideration, μ Ci/s. Calculated in the same manner as Q_T above.

The highest organ dose for a real receptor is determined by summing the dose contribution from all identified pathways for each receptor including ground contamination, inhalation, vegetable ingestion (for identified garden locations), cow and/or goat milk ingestion (if a cow or goat is identified for the location), beef ingestion (the beef ingestion dose for the location of highest beef dose for all receptors will be considered the beef dose for all receptors).

7.7.4 Population Doses

The population dose is determined using Equation D-1 from Regulatory Guide 1.109:

$$D = k \sum_m \text{POP}_m \sum_i D_{oij} \text{FP}_{ma}$$

For determining population doses to the 50-mile population around the plant, each compass sector is broken down into elements. These elements are defined in Table 7.5. Dispersion factors are calculated for the midpoint of each sector element (see Table 7.5). For each of these sector elements, an average dose is calculated, and then multiplied by the population in that sector element. The average dose is determined by multiplying the maximum individual dose for the sector by the ratio of the average to the maximum usage rates. For population doses resulting from ingestion, it is conservatively assumed that all food eaten by the average individual is grown within the sector element. The general equation used for calculating the population dose in a given sector element is:

$$\text{Dose}_{\text{pop}} = 0.001 \sum_P \text{RATIO}_P \text{POP}_m \text{FP}_a \text{DOSE}_P$$

where:

0.001 = conversion from mrem to rem.

RATIO_P = ratio of average to maximum dose for pathway P. Maximum ingestion rates are given in Table 6.3. (Average ingestion rates are obtained from Reference 4, Table E-4.)

= 0.5 for submersion and ground exposure pathways, a shielding/occupancy factor.

= 1.0 for the inhalation pathway.

= 0.515, 0.515, 0.5, and 0.355 for milk, for infant, child, teen and adult, respectively. (It is assumed that the ratio of average to maximum infant milk ingestion rates is the same as that for child.)

= 1.0, 0.90, 0.91, 0.86 for beef ingestion, for infant, child, teen and adult, respectively.

= 1.0, 0.38, 0.38, 0.37 for vegetable ingestion, for infant, child, teen and adult, respectively. (It is assumed that the average individual eats no fresh leafy vegetables, only stored vegetables.)

POP_m = the population of the sector element m, persons (Table 7.6).

FP_a = fraction of the population belonging to each age group.

= 0.015, 0.168, 0.153, 0.665 for infant, child, teen and adult, respectively (fractions taken from Reference 21, Table 3.39).

$DOSE_p$ = the dose for pathway P to the maximum individual at the location under consideration, mrem (as described in Sections 7.7.1, 7.7.2, and 7.7.3). For ingestion pathways, this dose is multiplied by an average decay correction to account for decay as the food is moved through the food distribution cycle. This average decay correction, ADC, is defined as follows:

For milk and vegetables:

$$ADC = \exp(-\lambda_i t_d) \quad (7.17)$$

For beef:

$$ADC = \frac{\exp(-\lambda_i t_d) \lambda_i t_{cb}}{1 - \exp(-\lambda_i t_{cb})} \quad (7.18)$$

where:

λ_i = decay constant for nuclide i, s.

t_d = distribution time for food product under consideration (values from Reference 4, Table D-1).

= 1.21E+06 s (14 d) for vegetables.

= 3.46E+05 s (4 d) for milk.

= 7d for beef

t_{cb} = time to consume a whole beef, as described in Section 7.8.3.

For beef ingestion, the additional factors in the calculation of ADC negate the integration of the dose term over the period during which a whole beef is consumed, for the calculation of population dose. In other words, this assumes that the maximum individual freezes and eats a whole beef, while the average individual buys smaller portions at a time.

Population doses are summed over all sector elements to obtain a total population dose for the 50-mile population.

7.7.5 Reporting of Doses

The calculated quarterly doses and calculated population doses described in Section 7.7 are reported in the Annual Radioactive Effluent Release Report as required by ODCM Administrative Control 5.2.

7.7.6 Dose to a MEMBER OF THE PUBLIC Inside the CONTROLLED or RESTRICTED AREA

The Basis for ODCM Control 1.2.2.1 states that for MEMBERS OF THE PUBLIC who may at times be within the CONTROLLED or RESTRICTED AREA, the occupancy factor of that MEMBER OF THE PUBLIC will usually be sufficiently low to compensate for any increase in the atmospheric dispersion factor above that for the unrestricted area boundary. This basis also states that examples of calculations for such MEMBERS OF THE PUBLIC will be given in the ODCM.

Calculations are presented in Section 12.4 of the WBN UFSAR which estimate the annual doses at the boundary of the restricted area (WBN UFSAR Table 12.4-2). The total dose rate is the sum of the adult whole body inhalation dose rate, the gamma dose rate from the plume and ground contamination, and the gamma dose rate from outdoor storage tanks. As indicated in the UFSAR, the highest total dose rate at the boundary of the restricted area is 105 mrem/y, based on a continuous 2000 h/y occupancy. Use of a more realistic occupancy, reflective of the transient traffic expected for this location, would result in a much lower dose estimate. It is, therefore, considered highly unlikely that a member of the public would receive greater than 100 mrem/y at or beyond the restricted area boundary.

In addition to this calculation, the dose to these MEMBERS OF THE PUBLIC (obtained from Thermoluminescent Dosimeters deployed at the Restricted Area Boundary and from estimates of the dose from gaseous effluents) will be reviewed on an annual basis to ensure that the actual exposure to any individuals is less than 100 mrem/y for these locations. The results of this review will be included in the Annual Radiological Effluent Report pursuant to ODCM Administrative Control 5.2.

7.8 GASEOUS RELEASES - DOSE FACTORS

7.8.1 Pasture Grass-Cow/Goat-Milk Ingestion Dose Factors - R_{CPI} (m^2 -mrem/y per $\mu Ci/s$)

The general dose equation stated in Regulatory Guide 1.109 for calculating the annual dose from consuming foods containing atmospherically released radionuclides (Equation C-13) is:

$$\text{Dose}(D) = \text{Dose Conversion Factor}(\text{DFL}) * \text{Usage Rate}(U) * \text{Radionuclide Concentration in Media}(C)$$

For the milk pathway, Regulatory Guide 1.109 Equations C-5 and C-10 are inserted into the above equation to yield the following:

$$D = \text{DFL} U_{ap} F_{mi} Q_f \exp(-\lambda_i t_{fm}) d_i \exp(-\lambda_i t_h) \left\{ \frac{r [1 - \exp(-\lambda_E t_e)]}{Y_p \lambda_E} + \frac{B_{iv} [1 - \exp(-\lambda_i t_b)]}{P \lambda_i} \right\} \exp(-\lambda_i t_h)$$

Since the dose equation in Sections 7.4 and 7.7.3 (Equations 7.9 and 7.14) contain the variable d_i (equal to the product of the release rate (Q) and the deposition factor (D/Q)), the factors remaining in the above equation are defined as the dose factor. For pasture grass, the variable t_h is defined as zero in Regulatory Guide 1.109, therefore that exponential term drops out of the equation. The resulting dose factor equation is:

$$R_{CPI} = 10^6 \text{DFL}_{iaj} U_{ap} F_{mi} Q_f \exp(-\lambda_i t_{fm}) f_p \left\{ \frac{r [1 - \exp(-\lambda_i t_{ep})]}{Y_p \lambda_E} + \frac{B_{iv} [1 - \exp(-\lambda_i t_b)]}{P \lambda_i} \right\} \quad (7.19)$$

where:

10^6 = conversion factor, pCi/ μCi .

DFL_{iaj} = ingestion dose conversion factor for nuclide i, age group a, organ j, mrem/pCi (Table 6.4).

U_{ap} = milk ingestion rate for age group a, L/y.

F_{mi} = transfer factor for nuclide i from animal's feed to milk, d/L (Table 6.2).

Q_f = animal's consumption rate, kg/d.

λ_i = decay constant for nuclide i, s^{-1} (Table 6.2).

t_{fm} = transport time from milking to receptor, s.

f_p = fraction of time animal spends on pasture, dimensionless.

r = fraction of activity retained on pasture grass, dimensionless.

λ_E = the effective decay constant, due to radioactive decay and weathering, s^{-1} .

$$= \lambda_i + \lambda_w.$$

λ_w = weathering decay constant for leaf and plant surfaces, s^{-1} .

t_{ep} = time pasture is exposed to deposition, s.

Y_p = agricultural productivity by unit area of pasture grass, kg/m².

B_{iv} = transfer factor for nuclide i from soil to vegetation, pCi/kg (wet weight of vegetation) per pCi/kg (dry soil). (Table 6.2)

t_b = time period over which accumulation on the ground is evaluated, s.

P = effective surface density of soil, kg/m².

NOTE: Factors defined above which do not reference a table for their numerical values are given in Table 6.3.

7.8.2 Stored Feed-Cow/Goat-Milk Ingestion Dose Factors - R_{CSI} (m^2 -mrem/y per $\mu Ci/s$)

The general dose equation stated in Regulatory Guide 1.109 for calculating the annual dose from consuming foods containing atmospherically released radionuclides (Equation C-13) is:

$$\text{Dose}(D) = \text{Dose Conversion Factor}(\text{DFL}) \cdot \text{Usage Rate}(U) \cdot \text{Radionuclide Concentration in Media}(C)$$

For the milk pathway, Regulatory Guide 1.109 Equations C-5 and C-10 are inserted into the above equation to yield the following:

$$D = \text{DFL } U_{ap} F_{mi} Q_f \exp(-\lambda_i t_{fm}) d_i \left\{ \frac{r [1 - \exp(-\lambda_E t_e)]}{Y_v \lambda_E} + \frac{B_{iv} [1 - \exp(-\lambda_i t_b)]}{P \lambda} \right\} \exp(-\lambda_i t_h)$$

Since the dose equation in Sections 7.4 and 7.7.3 (Equations 7.9 and 7.14) contain the variable d_i (equal to the product of the release rate (Q) and the deposition factor (D/Q)), the factors remaining in the above equation are defined as the dose factor. For stored feed, it is assumed that the milk animals will be eating the feed continuously from the time of harvest, therefore the decay term for the consumption of stored feed used is not that given in Reg. Guide 1.109 for the end of the period between harvest and consumption, but is instead an integrated decay over the period (Reference 10). The resulting dose factor is:

$$R_{CSI} = 10^6 \text{DFL}_{iaj} U_{ap} F_{mi} Q_f \exp(-\lambda_i t_{fm}) f_s \left\{ \frac{1 - \exp(-\lambda_i t_{csf})}{t_{csf} \lambda_i} \right\} \left\{ \frac{r [1 - \exp(-\lambda_i t_e)]}{Y_{sf} \lambda_E} + \frac{B_{iv} [1 - \exp(-\lambda_i t_b)]}{P \lambda_i} \right\} \quad (7.20)$$

where:

- 10^6 = conversion factor, $pCi/\mu Ci$.
- DFL_{iaj} = ingestion dose conversion factor for nuclide i , age group a , organ j , $mrem/pCi$ (Table 6.4).
- U_{ap} = milk ingestion rate for age group a , L/y .
- F_{mi} = transfer factor for nuclide i from animal's feed to milk, d/L (Table 6.2).
- Q_f = animal's consumption rate, kg/d .
- f_s = fraction of time animal spends on stored feed, dimensionless.
- λ_i = decay constant for nuclide i , s^{-1} (Table 6.2).
- t_{fm} = transport time from milking to receptor, s .
- t_{csf} = time between harvest of stored feed and consumption by animal, s .
- r = fraction of activity retained on pasture grass, dimensionless.
- λ_E = the effective decay constant, due to radioactive decay and weathering, s^{-1}
= $\lambda_i + \lambda_w$.
- λ_w = weathering decay constant for leaf and plant surfaces, s^{-1} .
- t_e = time stored feed is exposed to deposition, s .
- Y_{sf} = agricultural productivity by unit area of stored feed, kg/m^2 .
- B_{iv} = transfer factor for nuclide i from soil to vegetation, pCi/kg (wet weight of vegetation) per pCi/kg (dry soil). (Table 6.2)
- t_b = time period over which accumulation on the ground is evaluated, s .
- P = effective surface density of soil, kg/m^2 .

NOTE: Factors defined above which do not reference a table for their numerical values are given in Table 6.3.

7.8.3 Pasture Grass-Beef Ingestion Dose Factors - R_{MPI} (m^2 -mrem/y per $\mu Ci/s$)

The general dose equation stated in Regulatory Guide 1.109 for calculating the annual dose from consuming foods containing atmospherically released radionuclides (Equation C-13) is:

Dose(D) = Dose Conversion Factor(DFL)*Usage Rate(U)*Radionuclide Concentration in Media(C)

For the beef pathway, Regulatory Guide 1.109 Equations C-5 and C-12 are inserted into the above equation to yield the following:

$$D = DFL U_{op} F_f Q_f \exp(-\lambda_i t_s) d_i \left\{ \frac{r [1 - \exp(-\lambda_E t_e)]}{Y_V \lambda_E} + \frac{B_{iv} [1 - \exp(-\lambda_i t_b)]}{P \lambda_i} \right\} \exp(-\lambda_i t_h)$$

Since the dose equation in Sections 7.4 and 7.7.3 (Equations 7.9 and 7.14) contain the variable d_i (equal to the product of the release rate (Q) and the deposition factor (D/Q)), the factors remaining in the above equation are defined as the dose factor. In addition, a factor is added to account for the decay during the time the beef is being consumed. This term assumes that the individual slaughters and eats the animal over a period of time (t_{cb}) (Reference 10). For pasture grass, the variable t_h is defined as zero in Regulatory Guide 1.109, therefore that exponential term drops out of the equation. The resulting dose factor is:

$$R_{MPI} = 10^6 DFL_{iaj} U_{am} F_{fi} Q_f \left\{ \frac{[1 - \exp(-\lambda_i t_{cb})]}{\lambda_i t_{cb}} \right\} \exp(-\lambda_i t_s) f_p \left\{ \frac{r [1 - \exp(-\lambda_i t_{ep})]}{Y_V \lambda_E} + \frac{B_{iv} [1 - \exp(-\lambda_i t_b)]}{P \lambda_i} \right\} \quad (7.21)$$

where:

10^6 = conversion factor, pCi/ μCi .

DFL_{iaj} = ingestion dose conversion factor for nuclide i, age group a, organ j, mrem/pCi (Table 6.4).

U_{am} = beef ingestion rate for age group a, kg/y.

F_{fi} = transfer factor for nuclide i from cow's feed to beef, d/kg (Table 6.2).

Q_f = cow's consumption rate, kg/d.

λ_i = decay constant for nuclide i, s^{-1} (Table 6.2).

t_{cb} = time for receptor to consume a whole beef, s.

t_s = transport time from slaughter to consumer, s.

f_p = fraction of time cow spends on pasture, dimensionless.

r = fraction of activity retained on pasture grass, dimensionless.

λ_E = the effective decay constant, due to radioactive decay and weathering, s^{-1} , equal to $\lambda_i + \lambda_W$.

λ_W = weathering decay constant for leaf and plant surfaces, s^{-1} .

t_{ep} = time pasture is exposed to deposition, s.

Y_p = agricultural productivity by unit area of pasture grass, kg/m².

B_{iv} = transfer factor for nuclide i from soil to vegetation, pCi/kg (wet weight of vegetation) per pCi/kg (dry soil). (Table 6.2)

t_b = time over which accumulation on the ground is evaluated, s.

P = effective surface density of soil, kg/m².

NOTE: Factors defined above which do not reference a table for their numerical values are given in Table 6.3.

7.8.4 Stored Feed-Beef Ingestion Dose Factors - R_{MSI} (m^2 -mrem/y per $\mu Ci/s$)

The general dose equation stated in Regulatory Guide 1.109 for calculating the annual dose from consuming foods containing atmospherically released radionuclides (Equation C-13) is:

$$\text{Dose}(D) = \text{Dose Conversion Factor}(\text{DFL}) * \text{Usage Rate}(U) * \text{Radionuclide Concentration in Media}(C)$$

For the beef pathway, Regulatory Guide 1.109 Equations C-5 and C-12 are inserted into the above equation to yield the following:

$$D = \text{DFL } U_{ap} F_f Q_f \exp(-\lambda t_s) d_i \left\{ \frac{r [1 - \exp(-\lambda_E t_e)]}{Y_V \lambda_E} + \frac{B_{iv} [1 - \exp(-\lambda t_b)]}{P \lambda} \right\} \exp(-\lambda t_h)$$

Since the dose equation in Sections 7.4 and 7.7.3 (Equations 7.9 and 7.14) contain the variable d_i (equal to the product of the release rate (Q) and the deposition factor (D/Q)), the factors remaining in the above equation are defined as the dose factor. In addition, factors are added to account for the decay during the time the animals are consuming the stored feed (t_{csf}) and during the time period of over which the beef is being consumed (t_{cb}) (Reference 10). The resulting dose factor is:

$$R_{MSI} = 10^6 \text{DFL}_{iaj} U_{am} F_{fi} Q_f \left\{ \frac{[1 - \exp(-\lambda_i t_{cb})]}{\lambda_i t_{cb}} \right\} \exp(-\lambda_i t_s) f_s \left\{ \frac{[1 - \exp(-\lambda_i t_{csf})]}{\lambda_i t_{csf}} \right\} \left\{ \frac{r [1 - \exp(-\lambda_i t_e)]}{Y_V \lambda_E} + \frac{B_{iv} [1 - \exp(-\lambda_i t_b)]}{P \lambda_i} \right\} \quad (7.22)$$

where:

- 10^6 = conversion factor, pCi/ μ Ci.
- DFL_{iaj} = ingestion dose conversion factor for nuclide i, age group a, organ j, mrem/pCi (Table 6.4).
- U_{am} = beef ingestion rate for age group a, kg/y.
- F_{fi} = transfer factor for nuclide i from cow's feed to beef, d/kg (Table 6.2).
- Q_f = cow's consumption rate, kg/d.
- λ_i = decay constant for nuclide i, s^{-1} (Table 6.2).
- t_{cb} = time for receptor to consume a whole beef, s.
- t_s = transport time from slaughter to consumer, s.
- f_s = fraction of time cow spends on stored feed, dimensionless.
- t_{csf} = time between harvest of stored feed and consumption by cow, s.
- r = fraction of activity retained on pasture grass, dimensionless.
- t_e = time stored feed is exposed to deposition, s.
- Y_{sf} = agricultural productivity by unit area of stored feed, kg/ m^2 .
- λ_E = the effective decay constant, due to radioactive decay and weathering, s^{-1} ,
= $\lambda_i + \lambda_W$.
- λ_W = weathering decay constant for leaf and plant surfaces, s^{-1} .
- B_{iv} = transfer factor for nuclide i from soil to vegetation, pCi/kg (wet weight of vegetation) per pCi/kg (dry soil). (Table 6.2)
- t_b = time over which accumulation on the ground is evaluated, s.
- P = effective surface density of soil, kg/ m^2 .

NOTE: Factors defined above which do not reference a table for their numerical values are given in Table 6.3.

7.8.5 Fresh Leafy Vegetable Ingestion Dose Factors - R_{VFI} (m^2 -mrem/y per $\mu Ci/s$)

The general dose equation stated in Regulatory Guide 1.109 for calculating the annual dose from consuming foods containing atmospherically released radionuclides (Equation C-13) is:

$$\text{Dose}(D) = \text{Dose Conversion Factor(DFL)} * \text{Usage Rate}(U) * \text{Radionuclide Concentration in Media}(C)$$

For the vegetable pathway, Regulatory Guide 1.109 Equation C-5 is inserted into the above equation to yield the following:

$$D = \text{DFL} \text{UFL}_a d_i \left\{ \frac{r [1 - \exp(-\lambda_E t_e)]}{Y_V \lambda_E} + \frac{B_{iv} [1 - \exp(-\lambda_i t_b)]}{P \lambda_i} \right\} \exp(-\lambda_i t_{hc})$$

Since the dose equation in Sections 7.4 and 7.7.3 (Equations 7.9 and 7.14) contain the variable d_i (equal to the product of the release rate (Q) and the deposition factor (D/Q)), the factors remaining in the above equation are defined as the dose factor. Thus, the dose factor is:

$$RVFI = 10^6 \text{DFL}_{iaj} \exp(-\lambda_i t_{hc}) \text{UFL}_a f_L \left\{ \frac{r [1 - \exp(-\lambda_E t_e)]}{Y_f \lambda_E} + \frac{B_{iv} [1 - \exp(-\lambda_i t_b)]}{P \lambda_i} \right\} \quad (7.23)$$

where:

10^6 = conversion factor, pCi/ μ Ci.

DFL_{iaj} = ingestion dose conversion factor for nuclide i, age group a, organ j, mrem/pCi (Table 6.4).

λ_i = decay constant for nuclide i, s^{-1} (Table 6.2).

t_{hc} = average time between harvest of vegetables and their consumption and/or storage, s.

UFL_a = consumption rate of fresh leafy vegetables by the receptor in age group a, kg/y.

f_L = fraction of fresh leafy vegetables grown locally, dimensionless.

r = fraction of deposited activity retained on vegetables, dimensionless.

λ_E = the effective decay constant, due to radioactive decay and weathering, s^{-1} .

$$= \lambda_i + \lambda_W$$

λ_W = decay constant for removal of activity on leaf and plant surfaces by weathering, s^{-1} .

t_e = exposure time in garden for fresh leafy and/or stored vegetables, s.

Y_f = agricultural yield for fresh leafy vegetables, kg/ m^2 .

B_{iv} = transfer factor for nuclide i from soil to vegetables, pCi/kg (wet weight of vegetation) per pCi/kg (dry soil). (Table 6.2)

t_b = time period over which accumulation on the ground is evaluated, s.

P = effective surface density of soil, kg/ m^2 .

NOTE: Factors defined above which do not reference a table for their numerical values are given in Table 6.3.

7.8.6 Stored Vegetable Ingestion Dose Factors - R_{VSI} m²-mrem/y per μ Ci/s)

The general dose equation stated in Regulatory Guide 1.109 for calculating the annual dose from consuming foods containing atmospherically released radionuclides (Equation C-13) is:

$$\text{Dose}(D) = \text{Dose Conversion Factor}(\text{DFL}) \cdot \text{Usage Rate}(U) \cdot \text{Radionuclide Concentration in Media}(C)$$

For the vegetable pathway, Regulatory Guide 1.109 Equation C-5 is inserted into the above equation to yield the following:

$$D = \text{DFL} \cdot \text{UFL}_a \cdot d_i \left\{ \frac{r [1 - \exp(-\lambda_E t_e)]}{Y_v \lambda_E} + \frac{B_{iv} [1 - \exp(-\lambda t_b)]}{P \lambda} \right\} \exp(-\lambda t_{hc})$$

Since the dose equation in Sections 7.4 and 7.7.3 (Equations 7.9 and 7.14) contain the variable d_i (equal to the product of the release rate (Q) and the deposition factor (D/Q)), the factors remaining in the above equation are defined as the dose factor. One additional decay term is added to account for the decay during the period of time after harvest during which the food is consumed (t_{sv}); this term assumes that the stored vegetables are eaten throughout the storage period (Reference 10). Thus, the dose factor is:

$$RVS_i = 10^6 \text{DFL}_{iaj} \exp(-\lambda_i t_{hc}) U_{Sa} f_g \left\{ \frac{[1 - \exp(-\lambda_i t_{sv})]}{\lambda_i t_{sv}} \right\} \left\{ \frac{r [1 - \exp(-\lambda_E t_e)]}{Y_{sv} \lambda_E} + \frac{B_{iv} [1 - \exp(-\lambda_i t_b)]}{P \lambda_i} \right\} \quad (7.24)$$

where:

- 10^6 = conversion factor, pCi/ μ Ci.
- DFL_{iaj} = ingestion dose conversion factor for nuclide i, age group a, organ j, mrem/pCi (Table 6.4).
- λ_i = decay constant for nuclide i, s⁻¹ (Table 6.2).
- t_{hc} = average time between harvest of vegetables and their consumption and/or storage, s.
- U_{Sa} = consumption rate of stored vegetables by the receptor in age group a, kg/y.
- f_g = fraction of stored vegetables grown locally, dimensionless.
- t_{sv} = time between storage of vegetables and their consumption, s.
- r = fraction of deposited activity retained on vegetables, dimensionless.
- λ_E = the effective decay constant, due to radioactive decay and weathering, s⁻¹.
= $\lambda_i + \lambda_w$
- λ_w = decay constant for removal of activity on leaf and plant surfaces by weathering, s⁻¹.
- t_e = exposure time in garden for fresh leafy and/or stored vegetables, s.
- Y_{sv} = agricultural yield for stored vegetables, kg/m².
- B_{iv} = transfer factor for nuclide i from soil to vegetables, pCi/kg (wet weight of vegetation) per pCi/kg (dry soil). (Table 6.2)
- t_b = time period over which accumulation on the ground is evaluated, s.
- P = effective surface density of soil, kg/m².

NOTE: Factors defined above which do not reference a table for their numerical values are given in Table 6.3.

7.8.7 Tritium-Pasture Grass-Cow/Goat-Milk Dose Factor - R_{CPT} (mrem/y per $\mu\text{Ci}/\text{m}^3$)

The general dose equation stated in Regulatory Guide 1.109 for calculating the annual dose from consuming foods containing atmospherically released radionuclides (Equation C-13) is:

Dose(D) = Dose Conversion Factor(DFL)*Usage Rate(U)*Radionuclide Concentration in Media(C)

For the milk pathway, Regulatory Guide 1.109 Equations C-9 and C-10 are inserted into the above equation to yield the following:

$$D = \text{DFL} U_{\text{ap}} F_{\text{m}} Q_{\text{f}} \exp(-\lambda t_{\text{fm}}) Q_{\text{T}} \frac{\chi}{Q} \left[0.75 \left(\frac{0.5}{H} \right) \right]$$

Since the dose equation in Sections 7.4 and 7.7.3 (Equations 7.9 and 7.14) contain the variables for the release rate (Q) and the dispersion factor (χ/Q), the factors remaining in the above equation are defined as the dose factor. The resulting dose factor equation is:

$$RCT_P = 10^3 10^6 \text{DFL}_{\text{Taj}} F_{\text{mT}} Q_{\text{f}} U_{\text{ap}} \frac{\chi}{Q} \left[0.75 \left(\frac{0.5}{H} \right) \right] f_{\text{p}} \exp(-\lambda_{\text{T}} t_{\text{fm}}) \quad (7.25)$$

where:

10^3 = conversion factor, g/kg.

10^6 = conversion factor, pCi/ μCi .

DFL_{Taj} = ingestion dose conversion factor for tritium for age group a, organ j, mrem/pCi (Table 6.4).

F_{mT} = transfer factor for tritium from animal's feed to milk, d/L (Table 6.2).

Q_{f} = animal's consumption rate, kg/d.

U_{ap} = milk ingestion rate for age group a, L/y.

0.75 = the fraction of total feed that is water.

0.5 = the ratio of the specific activity of the feed grass water to the atmospheric water.

H = absolute humidity of the atmosphere, g/ m^3 .

f_{p} = fraction of time animal spends on pasture, dimensionless.

λ_{T} = decay constant for tritium, s^{-1} (Table 6.2).

t_{fm} = transport time from milking to receptor, s.

7.8.8 Tritium-Stored Feed-Cow/Goat-Milk Dose Factor - R_{CST} (mrem/y per $\mu\text{Ci}/\text{m}^3$)

The general dose equation stated in Regulatory Guide 1.109 for calculating the annual dose from consuming foods containing atmospherically released radionuclides (Equation C-13) is:

Dose(D) = Dose Conversion Factor(DFL)*Usage Rate(U)*Radionuclide Concentration in Media(C)

For the milk pathway, Regulatory Guide 1.109 Equations C-9 and C-10 are inserted into the above equation to yield the following:

$$D = \text{DFL} U_{\text{ap}} F_{\text{m}} Q_{\text{f}} \exp(-\lambda t_{\text{fm}}) Q_{\text{T}} \frac{\chi}{Q} \left[0.75 \left(\frac{0.5}{H} \right) \right] \quad (7.26)$$

Since the dose equation in Sections 7.4 and 7.7.3 (Equations 7.9 and 7.14) contain the variables for the release rate (Q) and the dispersion factor (χ/Q), the factors remaining in the above equation are defined as the dose factor. In addition, a factor is added to account for the decay during the time the animals are consuming the stored feed (Reference 10). The resulting dose factor is:

$$R_{CST} = 10^3 10^6 \text{DFL}_{\text{Taj}} F_{\text{fT}} Q_{\text{f}} U_{\text{am}} \frac{\chi}{Q} \left[0.75 \left(\frac{0.5}{H} \right) \right] f_{\text{s}} \exp(-\lambda_{\text{T}} t_{\text{s}}) \left\{ \frac{[1 - \exp(-\lambda_{\text{T}} t_{\text{csf}})]}{\lambda_{\text{T}} t_{\text{csf}}} \right\}$$

where:

10^3 = conversion factor, g/kg.

10^6 = conversion factor, pCi/ μCi .

DFL_{Taj} = ingestion dose conversion factor for H-3 for age group a, organ j, mrem/pCi (Table 6.4).

F_{fT} = transfer factor for H-3 from cow's feed to beef, d/kg (Table 6.2).

Q_{f} = cow's consumption rate, kg/d.

U_{am} = beef ingestion rate for age group a, kg/y.

0.75 = the fraction of total feed that is water.

0.5 = the ratio of the specific activity of the feed grass water to the atmospheric water.

H = absolute humidity of the atmosphere, g/ m^3 .

f_{s} = fraction of time cow spends on stored feed, dimensionless.

λ_{T} = decay constant for tritium, s^{-1} (Table 6.2).

t_{s} = transport time from slaughter to consumer, s.

t_{csf} = time to consume stored feed, s.

NOTE: Factors defined above which do not reference a table for their numerical values are given in Table 6.3.

7.8.9 Tritium-Pasture Grass-Beef Dose Factor - R_{MPT} (mrem/y per $\mu\text{Ci}/\text{m}^3$)

The general dose equation stated in Regulatory Guide 1.109 for calculating the annual dose from consuming foods containing atmospherically released radionuclides Equation C-13) is:

Dose(D) = Dose Conversion Factor(DFL)*Usage Rate(U)*Radionuclide Concentration in Media(C)

For the beef pathway, Regulatory Guide 1.109 Equations C-9 and C-10 are inserted into the above equation to yield the following:

$$D = \text{DFL} U_{\text{ap}} F_{\text{f}} Q_{\text{f}} \exp(-\lambda_{\text{T}} t_{\text{s}}) Q_{\text{T}} \frac{\chi}{Q} \left[0.75 \left(\frac{0.5}{H} \right) \right]$$

Since the dose equation in Sections 7.4 and 7.7.3 (Equations 7.9 and 7.14) contain the variables for the release rate (Q) and the dispersion factor (χ/Q), the factors remaining in the above equation are defined as the dose factor. Two decay terms are added to the equation to account for the decay during the time the pasture is exposed to the activity in the air, and the decay during the time the beef is being consumed (Reference 10). The resulting dose factor is:

$$R_{MPT} = 10^3 10^6 \text{DFL}_{\text{Taj}} F_{\text{fT}} Q_{\text{f}} U_{\text{am}} \left[0.75 \left(\frac{0.5}{H} \right) \right] f_{\text{p}} \exp(-\lambda_{\text{T}} t_{\text{s}}) \left\{ \frac{[1 - \exp(-\lambda_{\text{T}} t_{\text{ap}})]}{\lambda_{\text{T}} t_{\text{ap}}} \right\} \left\{ \frac{[1 - \exp(-\lambda_{\text{T}} t_{\text{cb}})]}{\lambda_{\text{T}} t_{\text{cb}}} \right\} \quad (7.27)$$

where:

10^3 = conversion factor, g/kg.

10^6 = conversion factor, pCi/ μCi .

DFL_{Taj} = ingestion dose conversion factor for H-3 for age group a, organ j, mrem/pCi (Table 6.4).

F_{fT} = transfer factor for H-3 from cow's feed to beef, d/kg (Table 6.2).

Q_{f} = cow's consumption rate, kg/d.

U_{am} = beef ingestion rate for age group a, kg/y.

0.75 = the fraction of total feed that is water.

0.5 = the ratio of the specific activity of the feed grass water to the atmospheric water.

H = absolute humidity of the atmosphere, g/ m^3 .

f_{p} = fraction of time cow spends on pasture, dimensionless.

λ_{T} = decay constant for tritium, s^{-1} (Table 6.2).

t_{s} = transport time from slaughter to consumer, s.

t_{cp} = time pasture is exposed to deposition, s.

t_{cb} = time for receptor to consume a whole beef, s.

7.8.10 Tritium-Stored Feed-Beef Dose Factor - R_{MST} (mrem/y per $\mu\text{Ci}/\text{m}^3$)

The general dose equation stated in Regulatory Guide 1.109 for calculating the annual dose from consuming foods containing atmospherically released radionuclides (Equation C-13) is:

$$\text{Dose}(D) = \text{Dose Conversion Factor}(\text{DFL}) * \text{Usage Rate}(U) * \text{Radionuclide Concentration in Media}(C)$$

For the beef pathway, Regulatory Guide 1.109 Equations C-9 and C-10 are inserted into the above equation to yield the following:

$$D = \text{DFL} U_{\text{am}} F_f Q_f \exp(-\lambda t_s) Q_T \frac{\chi}{Q} \left[0.75 \left(\frac{0.5}{H} \right) \right]$$

Since the dose equation in Sections 7.4 and 7.7.3 (Equations 7.9 and 7.14) contain the variables for the release rate (Q) and the dispersion factor (χ/Q), the factors remaining in the above equation are defined as the dose factor. Two decay terms are added to the equation to account for the decay during the time the pasture is exposed to the activity in the air, and the decay during the time the beef is being consumed (Reference 10). The resulting dose factor is:

$$R_{MST} = 10^3 10^6 \text{DFL}_{Taj} F_{ff} Q_f U_{\text{am}} \left[0.75 \left(\frac{0.5}{H} \right) \right] f_s \exp(-\lambda_T t_s) \left\{ \frac{[1 - \exp(-\lambda_T t_{cf})]}{\lambda_T t_{cf}} \right\} \left\{ \frac{[1 - \exp(-\lambda_T t_{cb})]}{\lambda_T t_{cb}} \right\} \quad (7.28)$$

where:

10^3 = conversion factor, g/kg.

10^6 = conversion factor, pCi/ μCi .

DFL_{Taj} = ingestion dose conversion factor for H-3 for age group a, organ j, mrem/pCi (Table 6.4).

F_{ff} = transfer factor for H-3 from cow's feed to beef, d/kg (Table 6.2).

Q_f = cow's consumption rate, kg/d.

U_{am} = beef ingestion rate for age group a, kg/y.

0.75 = the fraction of total feed that is water.

0.5 = the ratio of the specific activity of the feed grass water to the atmospheric water.

H = absolute humidity of the atmosphere, g/ m^3 .

f_s = fraction of time cow spends on stored feed, dimensionless.

λ_T = decay constant for tritium, s^{-1} (Table 6.2).

t_s = transport time from slaughter to consumer, s.

t_{cf} = time to consume stored feed, s.

t_{cb} = time for receptor to consume a whole beef, s.

NOTE: Factors defined above which do not reference a table for their numerical values are given in Table 6.3.

7.8.11 Tritium-Fresh Leafy Vegetable Dose Factor - R_{VFT} (mrem/y per $\mu\text{Ci}/\text{m}^3$)

The general dose equation stated in Regulatory Guide 1.109 for calculating the annual dose from consuming foods containing atmospherically released radionuclides (Equation C-13) is:

Dose(D) = Dose Conversion Factor(DFL)*Usage Rate(U)*Radionuclide Concentration in Media(C)

For the vegetable pathway, Regulatory Guide 1.109 Equation C-9 is inserted into the above equation to yield the following:

$$D = \text{DFL} U_{\text{ap}} \exp(-\lambda t_{\text{hc}}) Q_T \frac{\chi}{Q} \left[0.75 \left(\frac{0.5}{H} \right) \right]$$

Since the dose equation in Sections 7.4 and 7.7.3 (Equations 7.9 and 7.14) contain the variables for the release rate (Q) and the dispersion factor (χ/Q), the factors remaining in the above equation are defined as the dose factor. The resulting dose factor is:

$$R_{VFT} = 10^3 10^6 \text{DFL}_{\text{Taj}} \left[0.75 \left(\frac{0.5}{H} \right) \right] U_{\text{FLa}} f_L \exp(-\lambda_T t_{\text{hc}}) \quad (7.29)$$

where:

10^3 = conversion factor, g/kg.

10^6 = conversion factor, pCi/ μCi .

DFL_{Taj} = ingestion dose conversion factor for tritium for age group a, organ j, mrem/pCi (Table 6.4).

0.75 = the fraction of total vegetation that is water.

0.5 = the ratio of the specific activity of the vegetables water to the atmospheric water.

H = absolute humidity of the atmosphere, g/ m^3 .

U_{FLa} = consumption rate of fresh leafy vegetables by the receptor in age group a, kg/y.

f_L = fraction of fresh leafy vegetables grown locally, dimensionless.

λ_T = decay constant for tritium, s^{-1} (Table 6.2).

t_{hc} = time between harvest of vegetables and their consumption and/or storage, s.

NOTE: Factors defined above which do not reference a table for their numerical values are given in Table 6.3.

7.8.12 Tritium-Stored Vegetable Dose Factor - R_{VST} (mrem/y per $\mu\text{Ci}/\text{m}^3$)

The general dose equation stated in Regulatory Guide 1.109 for calculating the annual dose from consuming foods containing atmospherically released radionuclides (Equation C-13) is:

$$\text{Dose}(D) = \text{Dose Conversion Factor}(\text{DFL}) \cdot \text{Usage Rate}(U) \cdot \text{Radionuclide Concentration in Media}(C)$$

For the vegetable pathway, Regulatory Guide 1.109 Equation C-9 is inserted into the above equation to yield the following:

$$D = \text{DFL} U_{\text{ap}} \exp(-\lambda t_{\text{hc}}) Q_{\text{T}} \frac{\chi}{Q} \left[0.75 \left(\frac{0.5}{H} \right) \right]$$

Since the dose equation in Sections 7.4 and 7.7.3 (Equations 7.9 and 7.14) contain the variables for the release rate (Q) and the dispersion factor (χ/Q), the factors remaining in the above equation are defined as the dose factor. An additional decay term is added to account for the decay during the time the vegetables are stored (this term assumes that the vegetables are being eaten during the storage period) (Reference 10). The resulting dose factor is:

$$R_{VST} = 10^3 10^6 \text{DFL}_{\text{Taj}} \left[0.75 \left(\frac{0.5}{H} \right) \right] U_{\text{Sa}} f_{\text{g}} \left\{ \frac{[1 - \exp(-\lambda_{\text{T}} t_{\text{sv}})]}{\lambda_{\text{T}} t_{\text{sv}}} \right\} \exp(-\lambda_{\text{T}} t_{\text{hc}}) \quad (7.30)$$

where:

10^3 = conversion factor, g/kg.

10^6 = conversion factor, pCi/ μCi .

DFL_{Taj} = ingestion dose conversion factor for tritium for age group a, organ j, mrem/pCi (Table 6.4).

0.75 = the fraction of total vegetation that is water.

0.5 = the ratio of the specific activity of the vegetation water to the atmospheric water.

H = absolute humidity of the atmosphere, g/ m^3 .

U_{Sa} = consumption rate of stored vegetables by the receptor in age group a, kg/y.

f_{g} = fraction of stored vegetables grown locally, dimensionless.

λ_{T} = decay constant for tritium, s^{-1} (Table 6.2).

t_{sv} = time between harvest of stored vegetables and their consumption and/or storage, s.

t_{hc} = time between harvest of vegetables and their storage, s.

7.8.13 Inhalation Dose Factors - R_{II}
(mrem/y per $\mu\text{Ci}/\text{m}^3$)

The inhalation dose factors are calculated using the equation provided in NUREG-0133, Section 5.3.1.1.

$$R_{II} = 10^6 \text{ DFA}_{iaj} \text{ BR}_a \quad (7.31)$$

where:

10^6 = conversion factor, pCi/ μCi .

DFA_{iaj} = inhalation dose conversion factor for nuclide i, age group a and organ j, mrem/pCi (Table 7.7).

BR_a = breathing rate for age group a, m^3/y (Table 6.3).

7.8.14 Ground Plane Dose Factors - R_{GI}
(m^2 -mrem/y per $\mu\text{Ci}/\text{s}$)

The ground plane dose factors are calculated using the equation provided in NUREG-0133, Section 5.3.1.2. The shielding factor in that equation is conservatively assumed to be 1.0.

$$R_{GI} = 10^6 \text{ 8760 DFG}_{ij} \frac{1}{\lambda_i} [1 - \exp(-\lambda_i t_b)] \quad (7.32)$$

where:

10^6 = conversion factor, pCi/ μCi .

8760 = conversion factor, h/y.

DFG_{ij} = dose conversion factor for standing on contaminated ground for nuclide i and organ j (total body and skin), mrem/h per pCi/ m^2 (Table 6.6).

λ_i = decay constant of nuclide i, s^{-1} (Table 6.2).

t_b = time period over which the ground accumulation is evaluated, s (Table 6.3).

7.9 DISPERSION METHODOLOGY

Dispersion factors are calculated for radioactive effluent releases using hourly average meteorological data consisting of wind speed and direction measurements at 10m and temperature measurements at 10m and 46m.

A sector-average dispersion equation consistent with Regulatory Guide 1.111 is used. The dispersion model considers plume depletion (using information from Figure 7.4), and building wake effects. Terrain effects on dispersion are considered as described in Section 7.9.4.

Hourly average meteorological data are expressed as a joint-frequency distribution of wind speed, wind direction, and atmospheric stability. The joint-frequency distribution which represents the historical meteorological data for the period January 1974 to December 1993 is given in Table 7.2.

The wind speed classes that are used are as follows:

Number	Range (m/s)	Midpoint (m/s)
1	<0.3	0.13
2	0.3-0.6	0.45
3	0.7-1.5	1.10
4	1.6-2.4	1.99
5	2.5-3.3	2.88
6	3.4-5.5	4.45
7	5.6-8.2	6.91
8	8.3-10.9	9.59
9	>10.9	10.95

The stability classes that will be used are the standard Pasquill A through G classifications. The stability classes 1-7 will correspond to A=1, B=2, ..., G=7.

7.9.1 Air Concentration - X

Air concentrations of nuclides at downwind locations are calculated using the following equation:

$$X_i = \sum_{k=1}^9 \sum_{l=1}^7 \sqrt{\frac{2}{\pi}} \frac{f_{kl} Q_i p \text{TAF}}{\sum_{k=1}^9 u_k \left(\frac{2\pi x}{n}\right)} \exp\left(-\lambda_l \frac{x}{u_k}\right) \quad (7.33)$$

where:

f_{kl} = joint relative frequency of occurrence of winds in windspeed class k , stability class l , blowing toward this exposure point, expressed as a fraction.

Q_i = average annual release rate of radionuclide i , $\mu\text{Ci/s}$.

p = fraction of radionuclide remaining in plume (Figure 7.4).

TAF = site specific terrain adjustment factor (from Table 7.3). Calculated as described in Section 7.9.4.

Σ_{z1} = vertical dispersion coefficient for stability class l which includes a building wake adjustment,

$$= \sqrt{\sigma_{z1}^2 + \frac{c\alpha}{\pi}},$$

or $= \sqrt{3} \sigma_{z1}$, whichever is smaller.

where:

σ_{z1} is the vertical dispersion coefficient for stability class l (m) (Figure 7.5),

c is a building shape factor ($c=0.5$) (Reference 5),

α is the minimum building cross-sectional area (1630 m^2) (Reference 23).

u_k = midpoint value of wind speed class interval k , m/s.

- x = downwind distance, m.
 n = number of sectors, 16.
 λ_i = radioactive decay coefficient of radionuclide i , s^{-1}
 $2\pi x/n$ = sector width at point of interest, m.

7.9.2 Relative Concentration - χ/Q

Relative concentrations of nuclides at downwind locations are calculated using the following equation:

$$\frac{\chi}{Q} = \sum_{k=1}^9 \sum_{l=1}^7 \sqrt{\frac{2}{\pi}} \frac{f_{kl} \text{TAF}}{\sum_{j=1}^n u_j \left(\frac{2\pi x}{n}\right)} \quad (7.34)$$

where:

f_{kl} = joint relative frequency of occurrence of winds in windspeed class k , stability class l , blowing toward this exposure point, expressed as a fraction.

TAF = site specific terrain adjustment factor (from Table 7.3). Calculated as described in Section 7.9.4.

Σ_{z1} = vertical dispersion coefficient for stability class l which includes a building wake adjustment,

$$= \sqrt{\sigma_{z1}^2 + \frac{c\alpha}{\pi}},$$

or = $\sqrt{3} \sigma_{z1}$, whichever is smaller.

where:

σ_{z1} is the vertical dispersion coefficient for stability class l (m) (Figure 7.5),

c is a building shape factor ($c=0.5$) (Reference 5),

α is the minimum building cross-sectional area (1630 m^2) (Reference 23).

u_k = midpoint value of wind speed class interval k , m/s.

x = downwind distance, m.

n = number of sectors, 16.

$2\pi x/n$ = sector width at point of interest, m.

7.9.3 Relative Deposition - D/Q

Relative deposition of nuclides at downwind locations is calculated using the following equation:

$$\frac{D}{Q} = \sum_{k=1}^9 \sum_{l=1}^7 \frac{f_{kl} \text{ dr TAF}}{\left(\frac{2\pi x}{n}\right)} \quad (7.35)$$

where:

f_{kl} = joint relative frequency of occurrence of winds in windspeed class k and stability class l , blowing toward this exposure point, expressed as a fraction.

dr = relative deposition rate, m^{-1} (from Figure 7.6).

TAF = site specific terrain adjustment factor (from Table 7.3). Calculated as described in Section 7.9.4.

x = downwind distance, m.

n = number of sectors, 16.

$2\pi x/n$ = sector width at point of interest, m.

7.9.4 Terrain Adjustment Factor - TAF

As discussed in Reference 5, the straight-line dispersion model does not account for spatial and temporal variations in the airflow expected from the southwest-northeast aligned river valley. Such variations are considered by application of site-specific terrain adjustment factors, TAF. These factors were developed through the comparison of variable trajectory model results with straight-line model results for onsite meteorological data for 1978 (Reference 19). The ratio of the variable trajectory model dispersion factors to the straight-line model dispersion factors is defined as the TAF.

The dispersion factors used in the dose rate and dose calculations described in Sections 7.2.2, 7.2.3, 7.3.1, 7.3.2, and 7.4.1 are calculated using the meteorological data from the 1974 to 1993 period (in Table 7.2). χ/Q and D/Q values are calculated for each of the 16 UNRESTRICTED AREA BOUNDARY sector locations (Table 7.1). These are multiplied by the TAF associated with each of these sectors (see Table 7.3). The highest of these dispersion values are chosen for the dose or dose rate calculations.

The dispersion factors used in the dose calculations described in Section 7.7 are calculated using the actual meteorological data for the period. χ/Q or D/Q values are calculated using Equations 7.34 and 7.35 for the unrestricted area boundary locations identified in Table 7.1, for the 16 nearest resident locations, and all garden and milk animal locations identified in the annual land use census described in Section 9.3. The TAF values associated with these dispersion factors is the ratio of the dispersion factor calculated by the variable trajectory model to that calculated by the straight-line model for each of these locations using the 1978 meteorological data. These values will be calculated for all locations identified by the land use census and then used to modify the χ/Q and D/Q values determined with the actual meteorological data. Any TAF values of less than 1.0 will be defined as 1.0.

Table 7.1 - WBN - OFFSITE RECEPTOR LOCATION DATA

Receptor	Sector	DISTANCE from plant (m)	χ/Q^* (s/m ³)	D/Q* (1/m ²)
Unrestricted Area Boundary	N	1550	2.94E-06	4.89E-09
Unrestricted Area Boundary	NNE	1980	2.89E-06	6.78E-09
Unrestricted Area Boundary	NE	1580	3.50E-06	4.36E-09
Unrestricted Area Boundary	ENE	1370	5.11E-06	4.49E-09
Unrestricted Area Boundary	E	1280	5.93E-06	5.41E-09
Unrestricted Area Boundary	ESE	1250	5.67E-06	5.42E-09
Unrestricted Area Boundary	SE	1250	7.27E-06	6.80E-09
Unrestricted Area Boundary	SSE	1250	4.38E-06	5.66E-09
Unrestricted Area Boundary	S	1340	2.75E-06	5.68E-09
Unrestricted Area Boundary	SSW	1550	2.18E-06	5.45E-09
Unrestricted Area Boundary	SW	1670	2.16E-06	3.62E-09
Unrestricted Area Boundary	WSW	1430	3.97E-06	4.52E-09
Unrestricted Area Boundary	W	1460	2.35E-06	2.41E-09
Unrestricted Area Boundary	WNW	1400	9.48E-07	9.52E-10
Unrestricted Area Boundary	NW	1400	1.44E-06	1.48E-09
Unrestricted Area Boundary	NNW	1460	2.13E-06	2.49E-09
Liquid Discharge			N/A	N/A

NOTE: For quarterly airborne dose calculations, doses will also be calculated for all locations identified in the most recent land use census, and for any additional points deemed necessary.

*These χ/Q and D/Q values must be multiplied by the sector specific Terrain Adjustment Factor (from Table 7.3) prior to selecting the critical UNRESTRICTED AREA BOUNDARY location to be used in dose calculations.

Table 7.2 - JOINT PERCENTAGE FREQUENCIES OF WIND DIRECTION AND WIND SPEED FOR
DIFFERENT STABILITY CLASSES

(Page 1 of 7)

Stability Class A ($\Delta T \leq -1.9^\circ\text{C}/100\text{ M}$)
Watts Bar Nuclear Plant
January 1, 1974-December 31, 1993

Wind Dir	Calm	Wind Speed (mph)								TOTAL
		0.6- 1.4	1.5- 3.4	3.5- 5.4	5.5- 7.4	7.5- 12.4	12.5- 18.4	18.5- 24.4	≥ 24.5	
N	0.000	0.001	0.008	0.021	0.036	0.060	0.003	0.000	0.000	0.129
NNE	0.000	0.001	0.012	0.054	0.074	0.141	0.004	0.000	0.000	0.285
NE	0.000	0.000	0.035	0.088	0.078	0.089	0.000	0.000	0.000	0.289
ENE	0.000	0.001	0.037	0.079	0.071	0.032	0.000	0.000	0.000	0.220
E	0.000	0.002	0.037	0.041	0.015	0.005	0.000	0.000	0.000	0.100
ESE	0.000	0.000	0.016	0.016	0.002	0.001	0.000	0.000	0.000	0.035
SE	0.000	0.001	0.021	0.027	0.005	0.001	0.001	0.000	0.000	0.055
SSE	0.000	0.001	0.042	0.055	0.020	0.013	0.002	0.000	0.000	0.133
S	0.000	0.002	0.058	0.139	0.127	0.129	0.018	0.001	0.000	0.473
SSW	0.000	0.001	0.046	0.257	0.476	0.743	0.113	0.005	0.000	1.639
SW	0.000	0.000	0.018	0.093	0.118	0.102	0.012	0.000	0.000	0.343
WSW	0.000	0.000	0.006	0.016	0.017	0.063	0.021	0.002	0.000	0.125
W	0.000	0.000	0.004	0.010	0.014	0.064	0.014	0.001	0.000	0.106
WNW	0.000	0.000	0.001	0.004	0.007	0.033	0.005	0.000	0.000	0.050
NW	0.000	0.000	0.003	0.005	0.010	0.029	0.006	0.000	0.000	0.052
NNW	0.000	0.001	0.007	0.021	0.035	0.057	0.011	0.000	0.000	0.131
SUB- TOTAL	0.001	0.008	0.350	0.925	1.102	1.563	0.210	0.008	0.000	4.166

Total hours of valid stability observations 167789

Total hours of stability class A 6970

Total hours of valid wind direction-wind speed-stability class A 6849

Total hours of valid wind direction-wind speed-stability observations 164406

Total hours calm 1

Mean wind speed = 7.21

Meteorological facility located 0.8 km SSW of Watts Bar Nuclear Plant

Stability based on ΔT between 9.51 and 45.63 meters

Wind speed and direction measured at 9.72 meter level

NOTE: Totals and subtotals are obtained from unrounded numbers.

Table 7.2 - JOINT PERCENTAGE FREQUENCIES OF WIND DIRECTION AND WIND SPEED FOR
DIFFERENT STABILITY CLASSES

(Page 2 of 7)

Stability Class B (-1.9 < Delta-T <= -1.7°C/100 M)
Watts Bar Nuclear Plant
January 1, 1974-December 31, 1993

Wind Dir	Calm	Wind Speed (mph)							TOTAL	
		0.6-1.4	1.5-3.4	3.5-5.4	5.5-7.4	7.5-12.4	12.5-18.4	18.5-24.4		≥24.5
N	0.000	0.000	0.021	0.055	0.052	0.080	0.007	0.000	0.000	0.213
NNE	0.000	0.001	0.040	0.108	0.112	0.186	0.012	0.000	0.000	0.458
NE	0.000	0.000	0.069	0.123	0.107	0.086	0.002	0.000	0.000	0.387
ENE	0.000	0.001	0.052	0.101	0.071	0.024	0.000	0.000	0.000	0.249
E	0.000	0.001	0.061	0.055	0.015	0.002	0.000	0.000	0.000	0.133
ESE	0.000	0.002	0.021	0.024	0.002	0.001	0.000	0.000	0.000	0.049
SE	0.000	0.000	0.030	0.028	0.003	0.002	0.001	0.000	0.000	0.064
SSE	0.000	0.001	0.046	0.046	0.013	0.005	0.000	0.000	0.000	0.111
S	0.000	0.001	0.052	0.128	0.077	0.054	0.012	0.002	0.000	0.326
SSW	0.000	0.000	0.068	0.211	0.289	0.238	0.046	0.003	0.000	0.855
SW	0.000	0.000	0.027	0.114	0.080	0.029	0.003	0.000	0.000	0.252
WSW	0.000	0.000	0.007	0.024	0.026	0.023	0.007	0.000	0.000	0.085
W	0.000	0.000	0.005	0.010	0.023	0.049	0.012	0.001	0.000	0.099
WNW	0.000	0.000	0.005	0.005	0.019	0.060	0.007	0.000	0.000	0.097
NW	0.000	0.000	0.007	0.013	0.023	0.063	0.005	0.001	0.000	0.112
NNW	0.000	0.000	0.008	0.027	0.033	0.081	0.010	0.001	0.000	0.161
SUB-TOTAL	0.000	0.006	0.519	1.072	0.944	0.982	0.123	0.007	0.000	3.654

Total hours of valid stability observations 167789

Total hours of stability class B 6109

Total hours of valid wind direction-wind speed-stability class B 6007

Total hours of valid wind direction-wind speed-stability observations 164406

Total hours calm 0

Mean wind speed = 6.38

Meteorological facility located 0.8 km SSW of Watts Bar Nuclear Plant

Stability based on delta-T between 9.51 and 45.63 meters

Wind speed and direction measured at 9.72 meter level

NOTE: Totals and subtotals are obtained from unrounded numbers.

Table 7.2 - JOINT PERCENTAGE FREQUENCIES OF WIND DIRECTION AND WIND SPEED FOR
DIFFERENT STABILITY CLASSES

(Page 3 of 7)

Stability Class C (-1.7 < Delta-T <= -1.5°C/100 M)

Watts Bar Nuclear Plant

January 1, 1974-December 31, 1993

Wind Dir	Calm	Wind Speed (mph)								TOTAL
		0.6- 1.4	1.5- 3.4	3.5- 5.4	5.5- 7.4	7.5- 12.4	12.5- 18.4	18.5- 24.4	≥24.5	
N	0.000	0.001	0.041	0.099	0.117	0.154	0.008	0.000	0.000	0.419
NNE	0.000	0.001	0.099	0.205	0.221	0.292	0.019	0.000	0.000	0.837
NE	0.000	0.002	0.130	0.234	0.163	0.128	0.001	0.000	0.000	0.658
ENE	0.000	0.001	0.117	0.172	0.082	0.027	0.001	0.000	0.000	0.400
E	0.000	0.004	0.101	0.126	0.022	0.005	0.001	0.000	0.000	0.258
ESE	0.000	0.002	0.041	0.040	0.004	0.000	0.000	0.000	0.000	0.088
SE	0.000	0.001	0.055	0.056	0.008	0.001	0.002	0.000	0.000	0.123
SSE	0.000	0.001	0.085	0.109	0.029	0.012	0.004	0.000	0.000	0.238
S	0.000	0.001	0.116	0.245	0.114	0.068	0.017	0.001	0.000	0.561
SSW	0.000	0.001	0.099	0.418	0.375	0.268	0.062	0.004	0.000	1.227
SW	0.000	0.001	0.049	0.193	0.103	0.036	0.007	0.000	0.000	0.388
WSW	0.000	0.001	0.021	0.057	0.037	0.023	0.009	0.000	0.000	0.148
W	0.000	0.001	0.018	0.027	0.050	0.060	0.011	0.002	0.000	0.169
WNW	0.000	0.000	0.011	0.022	0.038	0.113	0.018	0.000	0.000	0.201
NW	0.000	0.000	0.020	0.040	0.051	0.144	0.015	0.001	0.000	0.270
NNW	0.000	0.000	0.024	0.056	0.081	0.129	0.011	0.000	0.000	0.301
SUB- TOTAL	0.000	0.015	1.027	2.097	1.494	1.460	0.184	0.009	0.000	6.286

Total hours of valid stability observations 167789

Total hours of stability class C 10556

Total hours of valid wind direction-wind speed-stability class C 10335

Total hours of valid wind direction-wind speed-stability observations 164406

Total hours calm 0

Mean wind speed = 6.06

Meteorological facility located 0.8 km SSW of Watts Bar Nuclear Plant

Stability based on delta-T between 9.51 and 45.63 meters

Wind speed and direction measured at 9.72 meter level

NOTE: Totals and subtotals are obtained from unrounded numbers.

Table 7.2 - JOINT PERCENTAGE FREQUENCIES OF WIND DIRECTION AND WIND SPEED FOR
DIFFERENT STABILITY CLASSES

(Page 4 of 7)

Stability Class D (-1.5 < Delta-T <= -0.5°C/100 M)
Watts Bar Nuclear Plant
January 1, 1974-December 31, 1993

Wind Dir	Calm	Wind Speed (mph)								TOTAL
		0.6-1.4	1.5-3.4	3.5-5.4	5.5-7.4	7.5-12.4	12.5-18.4	18.5-24.4	≥24.5	
N	0.005	0.046	0.502	0.875	0.968	1.192	0.046	0.000	0.000	3.634
NNE	0.006	0.043	0.584	1.226	1.348	1.457	0.063	0.000	0.000	4.729
NE	0.008	0.067	0.727	1.043	0.615	0.355	0.009	0.001	0.000	2.824
ENE	0.010	0.108	0.860	0.585	0.159	0.052	0.001	0.000	0.000	1.775
E	0.007	0.135	0.568	0.260	0.064	0.016	0.000	0.000	0.000	1.050
ESE	0.003	0.070	0.245	0.082	0.013	0.007	0.000	0.000	0.000	0.420
SE	0.005	0.078	0.378	0.151	0.029	0.023	0.007	0.000	0.000	0.670
SSE	0.007	0.130	0.591	0.256	0.052	0.046	0.018	0.002	0.000	1.102
S	0.011	0.133	0.991	0.816	0.339	0.294	0.100	0.011	0.001	2.697
SSW	0.014	0.106	1.259	1.837	1.071	1.119	0.246	0.021	0.000	5.671
SW	0.009	0.129	0.784	0.742	0.249	0.151	0.018	0.001	0.001	2.084
WSW	0.006	0.083	0.498	0.335	0.170	0.121	0.029	0.001	0.000	1.243
W	0.005	0.095	0.408	0.336	0.347	0.409	0.044	0.002	0.000	1.647
WNW	0.004	0.098	0.325	0.359	0.436	0.571	0.055	0.003	0.000	1.851
NW	0.004	0.080	0.341	0.398	0.530	0.748	0.069	0.001	0.000	2.171
NNW	0.004	0.048	0.370	0.526	0.626	0.903	0.047	0.000	0.000	2.524
SUB-TOTAL	0.108	1.450	9.430	9.829	7.016	7.464	0.751	0.042	0.001	36.091

Total hours of valid stability observations 167789

Total hours of stability class D 60312

Total hours of valid wind direction-wind speed-stability class D 59336

Total hours of valid wind direction-wind speed-stability observations 164406

Total hours calm 177

Mean wind speed = 5.37

Meteorological facility located 0.8 km SSW of Watts Bar Nuclear Plant

Stability based on delta-T between 9.51 and 45.63 meters

Wind speed and direction measured at 9.72 meter level

NOTE: Totals and subtotals are obtained from unrounded numbers.

Table 7.2 - JOINT PERCENTAGE FREQUENCIES OF WIND DIRECTION AND WIND SPEED FOR DIFFERENT STABILITY CLASSES
(Page 5 of 7)

Stability Class E (-0.5 < Delta-T <= 1.5°C/100 M)
Watts Bar Nuclear Plant
January 1, 1974-December 31, 1993

Wind Dir	Calm	Wind Speed (mph)								TOTAL
		0.6-1.4	1.5-3.4	3.5-5.4	5.5-7.4	7.5-12.4	12.5-18.4	18.5-24.4	≥24.5	
N	0.103	0.164	0.499	0.599	0.272	0.082	0.002	0.000	0.000	1.647
NNE	0.025	0.138	0.415	0.422	0.213	0.070	0.003	0.000	0.000	1.286
NE	0.030	0.156	0.513	0.266	0.088	0.030	0.000	0.000	0.000	1.085
ENE	0.057	0.280	0.988	0.290	0.040	0.009	0.001	0.000	0.000	1.662
E	0.034	0.304	0.461	0.083	0.016	0.010	0.001	0.000	0.000	0.910
ESE	0.013	0.148	0.147	0.028	0.007	0.002	0.001	0.000	0.000	0.347
SE	0.019	0.208	0.209	0.049	0.030	0.021	0.004	0.000	0.000	0.539
SSE	0.039	0.341	0.519	0.114	0.059	0.066	0.014	0.001	0.000	1.152
S	0.067	0.450	1.037	0.478	0.206	0.186	0.061	0.007	0.000	2.492
SSW	0.090	0.505	1.499	1.117	0.743	0.751	0.148	0.016	0.000	4.869
SW	0.071	0.566	1.008	0.300	0.176	0.131	0.021	0.002	0.000	2.274
WSW	0.063	0.651	0.764	0.178	0.106	0.071	0.010	0.001	0.000	1.844
W	0.059	0.671	0.645	0.222	0.111	0.067	0.008	0.000	0.000	1.783
WNW	0.055	0.626	0.595	0.214	0.091	0.037	0.002	0.001	0.000	1.622
NW	0.059	0.652	0.664	0.256	0.111	0.049	0.002	0.000	0.000	1.793
NNW	0.039	0.349	0.512	0.308	0.146	0.075	0.002	0.000	0.000	1.430
SUB-TOTAL	0.748	6.208	10.478	4.925	2.414	1.656	0.280	0.028	0.000	26.733

Total hours of valid stability observations 167789
 Total hours of stability class E 44959
 Total hours of valid wind direction-wind speed-stability class E 43951
 Total hours of valid wind direction-wind speed-stability observations 164406
 Total hours calm 1229
 Mean wind speed = 3.28

Meteorological facility located 0.8 km SSW of Watts Bar Nuclear Plant
 Stability based on delta-T between 9.51 and 45.63 meters
 Wind speed and direction measured at 9.72 meter level

NOTE: Totals and subtotals are obtained from unrounded numbers.

**Table 7.2 - JOINT PERCENTAGE FREQUENCIES OF WIND DIRECTION AND WIND SPEED FOR
DIFFERENT STABILITY CLASSES**

(Page 6 of 7)

Stability Class F ($1.5 < \Delta T \leq 4.0^\circ\text{C}/100 \text{ M}$)
Watts Bar Nuclear Plant
January 1, 1974-December 31, 1993

Wind Dir	Calm	Wind Speed (mph)							TOTAL	
		0.6- 1.4	1.5- 3.4	3.5- 5.4	5.5- 7.4	7.5- 12.4	12.5- 18.4	18.5- 24.4		≥ 24.5
N	0.051	0.288	0.245	0.027	0.006	0.001	0.000	0.000	0.000	0.617
NNE	0.043	0.230	0.219	0.027	0.001	0.001	0.000	0.000	0.000	0.520
NE	0.054	0.246	0.318	0.025	0.002	0.001	0.000	0.000	0.000	0.645
ENE	0.087	0.345	0.567	0.058	0.002	0.002	0.000	0.000	0.000	1.062
E	0.046	0.286	0.200	0.010	0.001	0.001	0.000	0.000	0.000	0.544
ESE	0.016	0.120	0.048	0.001	0.000	0.000	0.000	0.000	0.000	0.185
SE	0.023	0.159	0.082	0.005	0.001	0.000	0.000	0.000	0.000	0.270
SSE	0.042	0.254	0.189	0.018	0.002	0.002	0.000	0.000	0.000	0.508
S	0.061	0.338	0.304	0.040	0.005	0.004	0.000	0.000	0.000	0.751
SSW	0.078	0.387	0.435	0.175	0.063	0.013	0.000	0.000	0.000	1.151
SW	0.096	0.517	0.498	0.064	0.018	0.005	0.001	0.000	0.000	1.199
WSW	0.126	0.738	0.588	0.038	0.007	0.001	0.000	0.000	0.000	1.497
W	0.131	0.884	0.499	0.028	0.001	0.001	0.000	0.000	0.000	1.544
WNW	0.126	0.937	0.393	0.024	0.002	0.001	0.000	0.000	0.000	1.483
NW	0.184	1.225	0.707	0.041	0.004	0.002	0.001	0.000	0.000	2.164
NNW	0.099	0.644	0.398	0.030	0.004	0.000	0.000	0.000	0.000	1.175
SUB- TOTAL	1.262	7.599	5.690	0.609	0.119	0.035	0.001	0.000	0.000	15.315

Total hours of valid stability observations 167789

Total hours of stability class F 25810

Total hours of valid wind direction-wind speed-stability class F 25178

Total hours of valid wind direction-wind speed-stability observations 164406

Total hours calm 2075

Mean wind speed = 1.53

Meteorological facility located 0.8 km SSW of Watts Bar Nuclear Plant

Stability based on delta-T between 9.51 and 45.63 meters

Wind speed and direction measured at 9.72 meter level

NOTE: Totals and subtotals are obtained from unrounded numbers.

Table 7.2 - JOINT PERCENTAGE FREQUENCIES OF WIND DIRECTION AND WIND SPEED FOR
DIFFERENT STABILITY CLASSES

(Page 7 of 7)

Stability Class G (Delta-T > 4.0°C/100 M)
Watts Bar Nuclear Plant
January 1, 1974-December 31, 1993

Wind Dir	Calm	Wind Speed (mph)								TOTAL	
		0.6- 1.4	1.5- 3.4	3.5- 5.4	5.5- 7.4	7.5- 12.4	12.5- 18.4	18.5- 24.4	≥24.5		
N	0.034	0.195	0.066	0.001	0.000	0.000	0.000	0.000	0.000	0.000	0.296
NNE	0.038	0.196	0.095	0.002	0.000	0.000	0.000	0.000	0.000	0.000	0.330
NE	0.054	0.257	0.161	0.001	0.000	0.000	0.000	0.000	0.000	0.000	0.473
ENE	0.091	0.376	0.327	0.008	0.000	0.001	0.000	0.000	0.000	0.000	0.803
E	0.047	0.257	0.105	0.002	0.000	0.000	0.000	0.000	0.000	0.000	0.411
ESE	0.015	0.095	0.024	0.000	0.000	0.000	0.000	0.000	0.000	0.000	0.135
SE	0.027	0.159	0.049	0.000	0.000	0.000	0.000	0.000	0.000	0.000	0.235
SSE	0.031	0.176	0.065	0.002	0.000	0.000	0.000	0.000	0.000	0.000	0.274
S	0.035	0.192	0.075	0.005	0.001	0.000	0.000	0.000	0.000	0.000	0.308
SSW	0.042	0.217	0.107	0.012	0.002	0.000	0.000	0.000	0.000	0.000	0.379
SW	0.053	0.278	0.130	0.005	0.000	0.000	0.000	0.000	0.000	0.000	0.466
WSW	0.089	0.436	0.251	0.007	0.000	0.000	0.000	0.000	0.000	0.000	0.782
W	0.094	0.464	0.260	0.005	0.000	0.000	0.000	0.000	0.000	0.000	0.823
WNW	0.075	0.406	0.172	0.004	0.000	0.000	0.000	0.000	0.000	0.000	0.656
NW	0.101	0.516	0.264	0.010	0.001	0.000	0.000	0.000	0.000	0.000	0.892
NNW	0.056	0.306	0.128	0.003	0.000	0.000	0.000	0.000	0.000	0.000	0.494
SUB- TOTAL	0.881	4.524	2.273	0.068	0.004	0.001	0.000	0.000	0.000	0.000	7.755

Total hours of valid stability observations 167789

Total hours of stability class G 13073

Total hours of valid wind direction-wind speed-stability class G 12750

Total hours of valid wind direction-wind speed-stability observations 164406

Total hours calm 1448

Mean wind speed = 1.23

Meteorological facility located 0.8 km SSW of Watts Bar Nuclear Plant

Stability based on delta-T between 9.51 and 45.63 meters

Wind speed and direction measured at 9.72 meter level

NOTE: Totals and subtotals are obtained from unrounded numbers.

Table 7.3 - ADJUSTED DISPERSION FACTORS

Sector	TAF*	$\gamma/Q(TAF)$ (s/m ³)	D/Q(TAF) (1/m ²)
N	1.7	4.99E-06	8.31E-09
NNE	1.8	5.20E-06	1.22E-08
NE	2.1	7.34E-06	9.16E-09
ENE	1.7	8.68E-06	7.64E-09
E	1.6	9.48E-06	8.65E-09
ESE	1.8	1.02E-05	9.76E-09
SE	1.5	1.09E-05	1.02E-08
SSE	1.5	6.57E-06	8.49E-09
S	1.9	5.22E-06	1.08E-08
SSW	2.0	4.35E-06	1.09E-08
SW	2.1	4.53E-06	7.60E-09
WSW	1.8	7.15E-06	8.13E-09
W	1.2	2.82E-06	2.89E-09
WNW	2.5	2.37E-06	2.38E-09
NW	1.7	2.45E-06	2.52E-09
NNW	1.6	3.40E-06	3.99E-09

*The Site Specific Terrain Adjustment Factor (TAF) is equal to the ratio of the variable trajectory γ/Q to the straight-line γ/Q . See ODCM Section 7.9.4 for a full explanation.

Table 7.4 - DOSE FACTORS FOR SUBMERSION IN NOBLE GASES

	Submersion dose mrem/y per $\mu\text{Ci}/\text{m}^3$		Air dose mrad/y per $\mu\text{Ci}/\text{m}^3$	
	DF_{BI}	DF_{SI}	DF_{AI}	DF_{BI}
Kr-83m	7.56E-02	—	1.93E+01	2.88E+02
Kr-85m	1.17E+03	1.46E+03	1.23E+03	1.97E+03
Kr-85	1.61E+01	1.34E+03	1.72E+01	1.95E+03
Kr-87	5.92E+03	9.73E+03	6.17E+03	1.03E+04
Kr-88	1.47E+04	2.37E+03	1.52E+04	2.93E+03
Kr-89	1.66E+04	1.01E+04	1.73E+04	1.06E+04
Kr-90	1.56E+04	7.29E+03	1.63E+04	7.83E+03
Xe-131m	9.15E+01	4.76E+02	1.56E+02	1.11E+03
Xe-133m	2.51E+02	9.94E+02	3.27E+02	1.48E+03
Xe-133	2.94E+02	3.06E+02	3.53E+02	1.05E+03
Xe-135m	3.12E+03	7.11E+02	3.36E+03	7.39E+02
Xe-135	1.81E+03	1.86E+03	1.92E+03	2.46E+03
Xe-137	1.42E+03	1.22E+04	1.51E+03	1.27E+04
Xe-138	8.83E+03	4.13E+03	9.21E+03	4.75E+03
Ar-41	8.84E+03	2.69E+03	9.30E+03	3.28E+03

Reference:
Regulatory Guide 1.109, Table B-1.

Table 7.5 - SECTOR ELEMENTS CONSIDERED FOR POPULATION DOSES

Range of Sector Element (mi)	Midpoint of Sector Element (mi)
Unrestricted Area Boundary - 1	0.8
1 - 2	1.5
2 - 3	2.5
3 - 4	3.5
4 - 5	4.5
5 - 10	7.5
10 - 20	15
20 - 30	25
30 - 40	35
40 - 50	45

Table 7.6 - POPULATION WITHIN EACH SECTOR ELEMENT

	Distance from Site (miles)									
	0-1	1-2	2-3	3-4	4-5	5-10	10-20	20-30	30-40	40-50
N	0	111	32	47	135	893	2071	2166	3453	4040
NNE	0	25	25	76	43	796	8591	19187	9342	1194
NE	0	0	130	208	130	861	3381	19210	30623	54111
ENE	0	2	55	53	78	252	2445	9497	38457	136395
E	0	2	7	53	38	482	9716	8837	10649	17404
ESE	0	2	4	47	58	591	4514	12085	3420	300
SE	0	0	16	35	29	505	17835	10818	3969	3756
SSE	12	23	3	27	24	714	4018	8056	3899	6362
S	0	54	14	24	257	1368	1141	34699	40812	11522
SSW	0	34	7	19	32	739	5653	17523	25829	117868
SW	0	0	5	2	0	519	6490	9411	68565	125338
WSW	0	10	40	38	30	1281	10369	2091	7134	6571
W	2	5	19	59	65	837	965	5337	2839	2035
WNW	5	30	10	140	121	244	1461	2925	3440	17598
NW	0	10	111	113	387	2279	314	7266	7004	9802
NNW	0	0	62	87	98	2081	874	18279	4784	2983
Total	19	308	540	1028	1525	14442	79838	187387	264219	517279
									Total	1066585

1990 Population data from Reference 10

Table 7.7 - INHALATION DOSE FACTORS - DF_{Iao}
(mrem/pCi inhaled)
(Page 1 of 8)

Nuclide	ADULT						
	bone	liver	total body	thyroid	kidney	lung	GI-LLI
H-3	1.58E-07	1.58E-07	1.58E-07	1.58E-07	1.58E-07	1.58E-07	1.58E-07
C-14	2.27E-06	4.26E-07	4.26E-07	4.26E-07	4.26E-07	4.26E-07	4.26E-07
Na-24	1.28E-06	1.28E-06	1.28E-06	1.28E-06	1.28E-06	1.28E-06	1.28E-06
P-32	1.65E-04	9.64E-06	6.26E-06	0.00E+00	0.00E+00	0.00E+00	1.08E-05
Cr-51	0.00E+00	0.00E+00	1.25E-08	7.44E-09	2.85E-09	1.80E-06	4.15E-07
Mn-54	0.00E+00	4.95E-06	7.87E-07	0.00E+00	1.23E-06	1.75E-04	9.67E-06
Mn-56	0.00E+00	1.55E-10	2.29E-11	0.00E+00	1.63E-10	1.18E-06	2.53E-06
Fe-55	3.07E-06	2.12E-06	4.93E-07	0.00E+00	0.00E+00	9.01E-06	7.54E-07
Fe-59	1.47E-06	3.47E-06	1.32E-06	0.00E+00	0.00E+00	1.27E-04	2.35E-05
Co-57	0.00E+00	8.65E-08	8.39E-08	0.00E+00	0.00E+00	4.62E-05	3.93E-06
Co-58	0.00E+00	1.98E-07	2.59E-07	0.00E+00	0.00E+00	1.16E-04	1.33E-05
Co-60	0.00E+00	1.44E-06	1.85E-06	0.00E+00	0.00E+00	7.46E-04	3.56E-05
Ni-63	5.40E-05	3.93E-06	1.81E-06	0.00E+00	0.00E+00	2.23E-05	1.67E-06
Ni-65	1.92E-10	2.62E-11	1.14E-11	0.00E+00	0.00E+00	7.00E-07	1.54E-06
Cu-64	0.00E+00	1.83E-10	7.69E-11	0.00E+00	5.78E-10	8.48E-07	6.12E-06
Zn-65	4.05E-06	1.29E-05	5.82E-06	0.00E+00	8.62E-06	1.08E-04	6.68E-06
Zn-69	4.23E-12	8.14E-12	5.65E-13	0.00E+00	5.27E-12	1.15E-07	2.04E-09
Zn-69m	1.02E-09	2.45E-09	2.24E-10	0.00E+00	1.48E-09	2.38E-06	1.71E-05
Br-82	0.00E+00	0.00E+00	1.69E-06	0.00E+00	0.00E+00	0.00E+00	1.30E-06
Br-83	0.00E+00	0.00E+00	3.01E-08	0.00E+00	0.00E+00	0.00E+00	2.90E-08
Br-84	0.00E+00	0.00E+00	3.91E-08	0.00E+00	0.00E+00	0.00E+00	2.05E-13
Br-85	0.00E+00	0.00E+00	1.60E-09	0.00E+00	0.00E+00	0.00E+00	0.00E+00
Rb-86	0.00E+00	1.69E-05	7.37E-06	0.00E+00	0.00E+00	0.00E+00	2.08E-06
Rb-88	0.00E+00	4.84E-08	2.41E-08	0.00E+00	0.00E+00	0.00E+00	4.18E-19
Rb-89	0.00E+00	3.20E-08	2.12E-08	0.00E+00	0.00E+00	0.00E+00	1.16E-21
Sr-89	3.80E-05	0.00E+00	1.09E-06	0.00E+00	0.00E+00	1.75E-04	4.37E-05
Sr-90	1.24E-02	0.00E+00	7.62E-04	0.00E+00	0.00E+00	1.20E-03	9.02E-05
Sr-91	7.74E-09	0.00E+00	3.13E-10	0.00E+00	0.00E+00	4.56E-06	2.39E-05
Sr-92	8.43E-10	0.00E+00	3.64E-11	0.00E+00	0.00E+00	2.06E-06	5.38E-06
Y-90	2.61E-07	0.00E+00	7.01E-09	0.00E+00	0.00E+00	2.12E-05	6.32E-05
Y-91m	3.26E-11	0.00E+00	1.27E-12	0.00E+00	0.00E+00	2.40E-07	1.66E-10
Y-91	5.78E-05	0.00E+00	1.55E-06	0.00E+00	0.00E+00	2.13E-04	4.81E-05
Y-92	1.29E-09	0.00E+00	3.77E-11	0.00E+00	0.00E+00	1.96E-06	9.19E-06
Y-93	1.18E-08	0.00E+00	3.26E-10	0.00E+00	0.00E+00	6.06E-06	5.27E-05
Zr-95	1.34E-05	4.30E-06	2.91E-06	0.00E+00	6.77E-06	2.21E-04	1.88E-05
Zr-97	1.21E-08	2.45E-09	1.13E-09	0.00E+00	3.71E-09	9.84E-06	6.54E-05
Nb-95	1.76E-06	9.77E-07	5.26E-07	0.00E+00	9.67E-07	6.31E-05	1.30E-05
Nb-97	2.78E-11	7.03E-12	2.56E-12	0.00E+00	8.18E-12	3.00E-07	3.02E-08
Mo-99	0.00E+00	1.51E-08	2.87E-09	0.00E+00	3.64E-08	1.14E-05	3.10E-05
Tc-99m	1.29E-13	3.64E-13	4.63E-12	0.00E+00	5.52E-12	9.55E-08	5.20E-07
Tc-101	5.22E-15	7.52E-15	7.38E-14	0.00E+00	1.35E-13	4.99E-08	1.36E-21
Ru-103	1.91E-07	0.00E+00	8.23E-08	0.00E+00	7.29E-07	6.31E-05	1.38E-05
Ru-105	9.88E-11	0.00E+00	3.89E-11	0.00E+00	1.27E-10	1.37E-06	6.02E-06
Ru-106	8.64E-06	0.00E+00	1.09E-06	0.00E+00	1.67E-05	1.17E-03	1.14E-04

Table 7.7 - INHALATION DOSE FACTORS - DF_{Ino}
(mrem/pCi inhaled)
(Page 2 of 8)

Nuclide	ADULT						
	bone	liver	total body	thyroid	kidney	lung	GI-LLI
Ag-110m	1.35E-06	1.25E-06	7.43E-07	0.00E+00	2.46E-06	5.79E-04	3.78E-05
Sb-124	3.90E-06	7.36E-08	1.55E-06	9.44E-09	0.00E+00	3.10E-04	5.08E-05
Sb-125	6.67E-06	7.44E-08	1.58E-06	6.75E-09	0.00E+00	2.18E-04	1.26E-05
Sn-125	1.16E-06	3.12E-08	7.03E-08	2.59E-08	0.00E+00	7.37E-05	6.81E-05
Te-125m	4.27E-07	1.98E-07	5.84E-08	1.31E-07	1.55E-06	3.92E-05	8.83E-06
Te-127m	1.58E-06	7.21E-07	1.96E-07	4.11E-07	5.72E-06	1.20E-04	1.87E-05
Te-127	1.75E-10	8.03E-11	3.87E-11	1.32E-10	6.37E-10	8.14E-07	7.17E-06
Te-129m	1.22E-06	5.84E-07	1.98E-07	4.30E-07	4.57E-06	1.45E-04	4.79E-05
Te-129	6.22E-12	2.99E-12	1.55E-12	4.87E-12	2.34E-11	2.42E-07	1.96E-08
Te-131m	8.74E-09	5.45E-09	3.63E-09	6.88E-09	3.86E-08	1.82E-05	6.95E-05
Te-131	1.39E-12	7.44E-13	4.49E-13	1.17E-12	5.46E-12	1.74E-07	2.30E-09
Te-132	3.25E-08	2.69E-08	2.02E-08	2.37E-08	1.82E-07	3.60E-05	6.37E-05
I-130	5.72E-07	1.68E-06	6.60E-07	1.42E-04	2.61E-06	0.00E+00	9.61E-07
I-131	3.15E-06	4.47E-06	2.56E-06	1.49E-03	7.66E-06	0.00E+00	7.85E-07
I-132	1.45E-07	4.07E-07	1.45E-07	1.43E-05	6.48E-07	0.00E+00	5.08E-08
I-133	1.08E-06	1.85E-06	5.65E-07	2.69E-04	3.23E-06	0.00E+00	1.11E-06
I-134	8.05E-08	2.16E-07	7.69E-08	3.73E-06	3.44E-07	0.00E+00	1.26E-10
I-135	3.35E-07	8.73E-07	3.21E-07	5.60E-05	1.39E-06	0.00E+00	6.56E-07
Cs-134	4.66E-05	1.06E-04	9.10E-05	0.00E+00	3.59E-05	1.22E-05	1.30E-06
Cs-136	4.88E-06	1.83E-05	1.38E-05	0.00E+00	1.07E-05	1.50E-06	1.46E-06
Cs-137	5.98E-05	7.76E-05	5.35E-05	0.00E+00	2.78E-05	9.40E-06	1.05E-06
Cs-138	4.14E-08	7.76E-08	4.05E-08	0.00E+00	6.00E-08	6.07E-09	2.33E-13
Ba-139	1.17E-10	8.32E-14	3.42E-12	0.00E+00	7.78E-14	4.70E-07	1.12E-07
Ba-140	4.88E-06	6.13E-09	3.21E-07	0.00E+00	2.09E-09	1.59E-04	2.73E-05
Ba-141	1.25E-11	9.41E-15	4.20E-13	0.00E+00	8.75E-15	2.42E-07	1.45E-17
Ba-142	3.29E-12	3.38E-15	2.07E-13	0.00E+00	2.86E-15	1.49E-07	1.96E-26
La-140	4.30E-08	2.17E-08	5.73E-09	0.00E+00	0.00E+00	1.70E-05	5.73E-05
La-142	8.54E-11	3.88E-11	9.65E-12	0.00E+00	0.00E+00	7.91E-07	2.64E-07
Ce-141	2.49E-06	1.69E-06	1.91E-07	0.00E+00	7.83E-07	4.52E-05	1.50E-05
Ce-143	2.33E-08	1.72E-08	1.91E-09	0.00E+00	7.60E-09	9.97E-06	2.83E-05
Ce-144	4.29E-04	1.79E-04	2.30E-05	0.00E+00	1.06E-04	9.72E-04	1.02E-04
Pr-143	1.17E-06	4.69E-07	5.80E-08	0.00E+00	2.70E-07	3.51E-05	2.50E-05
Pr-144	3.76E-12	1.56E-12	1.91E-13	0.00E+00	8.81E-13	1.27E-07	2.69E-18
Nd-147	6.59E-07	7.62E-07	4.56E-08	0.00E+00	4.45E-07	2.76E-05	2.16E-05
W-187	1.06E-09	8.85E-10	3.10E-10	0.00E+00	0.00E+00	3.63E-06	1.94E-05
Np-239	2.87E-08	2.82E-09	1.55E-09	0.00E+00	8.75E-09	4.70E-06	1.49E-05

Reference:

Dose Factors for Co-57, Zn-69m, Br-82, Nb-97, Sb-124, Sb-125 are from Reference 17, Table 8.
All others from: Regulatory Guide 1.109, Table E-7.

NOTE: The tritium dose factor for bone is assumed to be equal to the total body dose factor. This assumes that tritium will act similarly in all organs (Reference 24).

Table 7.7 - INHALATION DOSE FACTORS - DF_{ino}

(mrem/pCi inhaled)

(Page 3 of 8)

TEEN

Nuclide	bone	liver	total body	thyroid	kidney	lung	GI-LLI
H-3	1.59E-07	1.59E-07	1.59E-07	1.59E-07	1.59E-07	1.59E-07	1.59E-07
C-14	3.25E-06	6.09E-07	6.09E-07	6.09E-07	6.09E-07	6.09E-07	6.09E-07
Na-24	1.72E-06	1.72E-06	1.72E-06	1.72E-06	1.72E-06	1.72E-06	1.72E-06
P-32	2.36E-04	1.37E-05	8.95E-06	0.00E+00	0.00E+00	0.00E+00	1.16E-05
Cr-51	0.00E+00	0.00E+00	1.69E-08	9.37E-09	3.84E-09	2.62E-06	3.75E-07
Mn-54	0.00E+00	6.39E-06	1.05E-06	0.00E+00	1.59E-06	2.48E-04	8.35E-06
Mn-56	0.00E+00	2.12E-10	3.15E-11	0.00E+00	2.24E-10	1.90E-06	7.18E-06
Fe-55	4.18E-06	2.98E-06	6.93E-07	0.00E+00	0.00E+00	1.55E-05	7.99E-07
Fe-59	1.99E-06	4.62E-06	1.79E-06	0.00E+00	0.00E+00	1.91E-04	2.23E-05
Co-57	0.00E+00	1.18E-07	1.15E-07	0.00E+00	0.00E+00	7.33E-05	3.93E-06
Co-58	0.00E+00	2.59E-07	3.47E-07	0.00E+00	0.00E+00	1.68E-04	1.19E-05
Co-60	0.00E+00	1.89E-06	2.48E-06	0.00E+00	0.00E+00	1.09E-03	3.24E-05
Ni-63	7.25E-05	5.43E-06	2.47E-06	0.00E+00	0.00E+00	3.84E-05	1.77E-06
Ni-65	2.73E-10	3.66E-11	1.59E-11	0.00E+00	0.00E+00	1.17E-06	4.59E-06
Cu-64	0.00E+00	2.54E-10	1.06E-10	0.00E+00	8.01E-10	1.39E-06	7.68E-06
Zn-65	4.82E-06	1.67E-05	7.80E-06	0.00E+00	1.08E-05	1.55E-04	5.83E-06
Zn-69	6.04E-12	1.15E-11	8.07E-13	0.00E+00	7.53E-12	1.98E-07	3.56E-08
Zn-69m	1.44E-09	3.39E-09	3.11E-10	0.00E+00	2.06E-09	3.92E-06	2.14E-05
Br-82	0.00E+00	0.00E+00	2.28E-06	0.00E+00	0.00E+00	0.00E+00	0.00E+00
Br-83	0.00E+00	0.00E+00	4.30E-08	0.00E+00	0.00E+00	0.00E+00	0.00E+00
Br-84	0.00E+00	0.00E+00	5.41E-08	0.00E+00	0.00E+00	0.00E+00	0.00E+00
Br-85	0.00E+00	0.00E+00	2.29E-09	0.00E+00	0.00E+00	0.00E+00	0.00E+00
Rb-86	0.00E+00	2.38E-05	1.05E-05	0.00E+00	0.00E+00	0.00E+00	2.21E-06
Rb-88	0.00E+00	6.82E-08	3.40E-08	0.00E+00	0.00E+00	0.00E+00	3.65E-15
Rb-89	0.00E+00	4.40E-08	2.91E-08	0.00E+00	0.00E+00	0.00E+00	4.22E-17
Sr-89	5.43E-05	0.00E+00	1.56E-06	0.00E+00	0.00E+00	3.02E-04	4.64E-05
Sr-90	1.35E-02	0.00E+00	8.35E-04	0.00E+00	0.00E+00	2.06E-03	9.56E-05
Sr-91	1.10E-08	0.00E+00	4.39E-10	0.00E+00	0.00E+00	7.59E-06	3.24E-05
Sr-92	1.19E-09	0.00E+00	5.08E-11	0.00E+00	0.00E+00	3.43E-06	1.49E-05
Y-90	3.73E-07	0.00E+00	1.00E-08	0.00E+00	0.00E+00	3.66E-05	6.99E-05
Y-91m	4.63E-11	0.00E+00	1.77E-12	0.00E+00	0.00E+00	4.00E-07	3.77E-09
Y-91	8.26E-05	0.00E+00	2.21E-06	0.00E+00	0.00E+00	3.67E-04	5.11E-05
Y-92	1.84E-09	0.00E+00	5.36E-11	0.00E+00	0.00E+00	3.35E-06	2.06E-05
Y-93	1.69E-08	0.00E+00	4.65E-10	0.00E+00	0.00E+00	1.04E-05	7.24E-05
Zr-95	1.82E-05	5.73E-06	3.94E-06	0.00E+00	8.42E-06	3.36E-04	1.86E-05
Zr-97	1.72E-08	3.40E-09	1.57E-09	0.00E+00	5.15E-09	1.62E-05	7.88E-05
Nb-95	2.32E-06	1.29E-06	7.08E-07	0.00E+00	1.25E-06	9.39E-05	1.21E-05
Nb-97	3.92E-11	9.72E-12	3.55E-12	0.00E+00	1.14E-11	4.91E-07	2.71E-07
Mo-99	0.00E+00	2.11E-08	4.03E-09	0.00E+00	5.14E-08	1.92E-05	3.36E-05
Tc-99m	1.73E-13	4.83E-13	6.24E-12	0.00E+00	7.20E-12	1.44E-07	7.66E-07
Tc-101	7.40E-15	1.05E-14	1.03E-13	0.00E+00	1.90E-13	8.34E-08	1.09E-16
Ru-103	2.63E-07	0.00E+00	1.12E-07	0.00E+00	9.29E-07	9.79E-05	1.36E-05
Ru-105	1.40E-10	0.00E+00	5.42E-11	0.00E+00	1.76E-10	2.27E-06	1.13E-05
Ru-106	1.23E-05	0.00E+00	1.55E-06	0.00E+00	2.38E-05	2.01E-03	1.20E-04

Table 7.7 - INHALATION DOSE FACTORS - DF_{Ino}
(mrem/pCi inhaled)
(Page 4 of 8)

Nuclide	TEEN						
	bone	liver	total body	thyroid	kidney	lung	GI-LLI
Ag-110m	1.73E-06	1.64E-06	9.99E-07	0.00E+00	3.13E-06	8.44E-04	3.41E-05
Sb-124	5.38E-06	9.92E-08	2.10E-06	1.22E-08	0.00E+00	4.81E-04	4.98E-05
Sb-125	9.23E-06	1.01E-07	2.15E-06	8.80E-09	0.00E+00	3.42E-04	1.24E-05
Te-125m	6.10E-07	2.80E-07	8.34E-08	1.75E-07	0.00E+00	6.70E-05	9.38E-06
Te-127m	2.25E-06	1.02E-06	2.73E-07	5.48E-07	8.17E-06	2.07E-04	1.99E-05
Te-127	2.51E-10	1.14E-10	5.52E-11	1.77E-10	9.10E-10	1.40E-06	1.01E-05
Te-129m	1.74E-06	8.23E-07	2.81E-07	5.72E-07	6.49E-06	2.47E-04	5.06E-05
Te-129	8.87E-12	4.22E-12	2.20E-12	6.48E-12	3.32E-11	4.12E-07	2.02E-07
Te-131m	1.23E-08	7.51E-09	5.03E-09	9.06E-09	5.49E-08	2.97E-05	7.76E-05
Te-131	1.97E-12	1.04E-12	6.30E-13	1.55E-12	7.72E-12	2.92E-07	1.89E-09
Te-132	4.50E-08	3.63E-08	2.74E-08	3.07E-08	2.44E-07	5.61E-05	5.79E-05
I-130	7.80E-07	2.24E-06	8.96E-07	1.86E-04	3.44E-06	0.00E+00	1.14E-06
I-131	4.43E-06	6.14E-06	3.30E-06	1.83E-03	1.05E-05	0.00E+00	8.11E-07
I-132	1.99E-07	5.47E-07	1.97E-07	1.89E-05	8.65E-07	0.00E+00	1.59E-07
I-133	1.52E-06	2.56E-06	7.78E-07	3.65E-04	4.49E-06	0.00E+00	1.29E-06
I-134	1.11E-07	2.90E-07	1.05E-07	4.94E-06	4.58E-07	0.00E+00	2.55E-09
I-135	4.62E-07	1.18E-06	4.36E-07	7.76E-05	1.86E-06	0.00E+00	8.69E-07
Cs-134	6.28E-05	1.41E-04	6.86E-05	0.00E+00	4.69E-05	1.83E-05	1.22E-06
Cs-136	6.44E-06	2.42E-05	1.71E-05	0.00E+00	1.38E-05	2.22E-06	1.36E-06
Cs-137	8.38E-05	1.06E-04	3.89E-05	0.00E+00	3.80E-05	1.51E-05	1.06E-06
Cs-138	5.82E-08	1.07E-07	5.58E-08	0.00E+00	8.28E-08	9.84E-09	3.38E-11
Ba-139	1.67E-10	1.18E-13	4.87E-12	0.00E+00	1.11E-13	8.08E-07	8.06E-07
Ba-140	6.84E-06	8.38E-09	4.40E-07	0.00E+00	2.85E-09	2.54E-04	2.86E-05
Ba-141	1.78E-11	1.32E-14	5.93E-13	0.00E+00	1.23E-14	4.11E-07	9.33E-14
Ba-142	4.62E-12	4.63E-15	2.84E-13	0.00E+00	3.92E-15	2.39E-07	5.99E-20
La-140	5.99E-08	2.95E-08	7.82E-09	0.00E+00	0.00E+00	2.68E-05	6.09E-05
La-142	1.20E-10	5.31E-11	1.32E-11	0.00E+00	0.00E+00	1.27E-06	1.50E-06
Ce-141	3.55E-06	2.37E-06	2.71E-07	0.00E+00	1.11E-06	7.67E-05	1.58E-05
Ce-143	3.32E-08	2.42E-08	2.70E-09	0.00E+00	1.08E-08	1.63E-05	3.19E-05
Ce-144	6.11E-04	2.53E-04	3.28E-05	0.00E+00	1.51E-04	1.67E-03	1.08E-04
Pr-143	1.67E-06	6.64E-07	8.28E-08	0.00E+00	3.86E-07	6.04E-05	2.67E-05
Pr-144	5.37E-12	2.20E-12	2.72E-13	0.00E+00	1.26E-12	2.19E-07	2.94E-14
Nd-147	9.83E-07	1.07E-06	6.41E-08	0.00E+00	6.28E-07	4.65E-05	2.28E-05
W-187	1.50E-09	1.22E-09	4.29E-10	0.00E+00	0.00E+00	5.92E-06	2.21E-05
Np-239	4.23E-08	3.99E-09	2.21E-09	0.00E+00	1.25E-08	8.11E-06	1.65E-05

References:

Dose Factors for Co-57, Zn-69m, Br-82, Nb-97, Sb-124, Sb-125 are from Reference 17, Table 8.
All others from: Regulatory Guide 1.109, Table E-8.

NOTE: The tritium dose factor for bone is assumed to be equal to the total body dose factor. This assumes that tritium will act similarly in all organs (Reference 24).

Table 7.7 - INHALATION DOSE FACTORS - $DF_{h,io}$
(mrem/pCi inhaled)
(Page 5 of 8)

Nuclide	CHILD						
	bone	liver	total body	thyroid	kidney	lung	GI-LLI
H-3	3.04E-07	3.04E-07	3.04E-07	3.04E-07	3.04E-07	3.04E-07	3.04E-07
C-14	9.70E-06	1.82E-06	1.82E-06	1.82E-06	1.82E-06	1.82E-06	1.82E-06
Na-24	4.35E-06	4.35E-06	4.35E-06	4.35E-06	4.35E-06	4.35E-06	4.35E-06
P-32	7.04E-04	3.09E-05	2.67E-05	0.00E+00	0.00E+00	0.00E+00	1.14E-05
Cr-51	0.00E+00	0.00E+00	4.17E-08	2.31E-08	6.57E-09	4.59E-06	2.93E-07
Mn-54	0.00E+00	1.16E-05	2.57E-06	0.00E+00	2.71E-06	4.26E-04	6.19E-06
Mn-56	0.00E+00	4.48E-10	8.43E-11	0.00E+00	4.52E-10	3.55E-06	3.33E-05
Fe-55	1.28E-05	6.80E-06	2.10E-06	0.00E+00	0.00E+00	3.00E-05	7.75E-07
Fe-59	5.59E-06	9.04E-06	4.51E-06	0.00E+00	0.00E+00	3.43E-04	1.91E-05
Co-57	0.00E+00	2.44E-07	2.88E-07	0.00E+00	0.00E+00	1.37E-04	3.58E-06
Co-58	0.00E+00	4.79E-07	8.55E-07	0.00E+00	0.00E+00	2.99E-04	9.29E-06
Co-60	0.00E+00	3.55E-06	6.12E-06	0.00E+00	0.00E+00	1.91E-03	2.60E-05
Ni-63	2.22E-04	1.25E-05	7.56E-06	0.00E+00	0.00E+00	7.43E-05	1.71E-06
Ni-65	8.08E-10	7.99E-11	4.44E-11	0.00E+00	0.00E+00	2.21E-06	2.27E-05
Cu-64	0.00E+00	5.39E-10	2.90E-10	0.00E+00	1.63E-09	2.59E-06	9.92E-06
Zn-65	1.15E-05	3.06E-05	1.90E-05	0.00E+00	1.93E-05	2.69E-04	4.41E-06
Zn-69	1.81E-11	2.61E-11	2.41E-12	0.00E+00	1.58E-11	3.84E-07	2.75E-06
Zn-69m	4.26E-09	7.28E-09	8.59E-10	0.00E+00	4.22E-09	7.36E-06	2.71E-05
Br-82	0.00E+00	0.00E+00	5.66E-06	0.00E+00	0.00E+00	0.00E+00	0.00E+00
Br-83	0.00E+00	0.00E+00	1.28E-07	0.00E+00	0.00E+00	0.00E+00	0.00E+00
Br-84	0.00E+00	0.00E+00	1.48E-07	0.00E+00	0.00E+00	0.00E+00	0.00E+00
Br-85	0.00E+00	0.00E+00	6.84E-09	0.00E+00	0.00E+00	0.00E+00	0.00E+00
Rb-86	0.00E+00	5.36E-05	3.09E-05	0.00E+00	0.00E+00	0.00E+00	2.16E-06
Rb-88	0.00E+00	1.52E-07	9.90E-08	0.00E+00	0.00E+00	0.00E+00	4.66E-09
Rb-89	0.00E+00	9.33E-08	7.83E-08	0.00E+00	0.00E+00	0.00E+00	5.11E-10
Sr-89	1.62E-04	0.00E+00	4.66E-06	0.00E+00	0.00E+00	5.83E-04	4.52E-05
Sr-90	2.73E-02	0.00E+00	1.74E-03	0.00E+00	0.00E+00	3.99E-03	9.28E-05
Sr-91	3.28E-08	0.00E+00	1.24E-09	0.00E+00	0.00E+00	1.44E-05	4.70E-05
Sr-92	3.54E-09	0.00E+00	1.42E-10	0.00E+00	0.00E+00	6.49E-06	6.55E-05
Y-90	1.11E-06	0.00E+00	2.99E-08	0.00E+00	0.00E+00	7.07E-05	7.24E-05
Y-91m	1.37E-10	0.00E+00	4.98E-12	0.00E+00	0.00E+00	7.60E-07	4.64E-07
Y-91	2.47E-04	0.00E+00	6.59E-06	0.00E+00	0.00E+00	7.10E-04	4.97E-05
Y-92	5.50E-09	0.00E+00	1.57E-10	0.00E+00	0.00E+00	6.46E-06	6.46E-05
Y-93	5.04E-08	0.00E+00	1.38E-09	0.00E+00	0.00E+00	2.01E-05	1.05E-04
Zr-95	5.13E-05	1.13E-05	1.00E-05	0.00E+00	1.61E-05	6.03E-04	1.65E-05
Zr-97	5.07E-08	7.34E-09	4.32E-09	0.00E+00	1.05E-08	3.06E-05	9.49E-05
Nb-95	6.35E-06	2.48E-06	1.77E-06	0.00E+00	2.33E-06	1.66E-04	1.00E-05
Nb-97	1.16E-10	2.08E-11	9.74E-12	0.00E+00	2.31E-11	9.23E-07	7.52E-06
Mo-99	0.00E+00	4.66E-08	1.15E-08	0.00E+00	1.06E-07	3.66E-05	3.42E-05
Tc-99m	4.81E-13	9.41E-13	1.56E-11	0.00E+00	1.37E-11	2.57E-07	1.30E-06
Tc-101	2.19E-14	2.30E-14	2.91E-13	0.00E+00	3.92E-13	1.58E-07	4.41E-09
Ru-103	7.55E-07	0.00E+00	2.90E-07	0.00E+00	1.90E-06	1.79E-04	1.21E-05
Ru-105	4.13E-10	0.00E+00	1.50E-10	0.00E+00	3.63E-10	4.30E-06	2.69E-05
Ru-106	3.68E-05	0.00E+00	4.57E-06	0.00E+00	4.97E-05	3.87E-03	1.16E-04

Table 7.7 - INHALATION DOSE FACTORS - DF_{iao}
(mrem/pCi inhaled)
(Page 6 of 8)

Nuclide	CHILD						
	bone	liver	total body	thyroid	kidney	lung	GI-LLI
Ag-110m	4.56E-06	3.08E-06	2.47E-06	0.00E+00	5.74E-06	1.48E-03	2.71E-05
Sb-124	1.55E-05	2.00E-07	5.41E-06	3.41E-08	0.00E+00	8.76E-04	4.43E-05
Sb-125	2.66E-05	2.05E-07	5.59E-06	2.46E-08	0.00E+00	6.27E-04	1.09E-05
Te-125m	1.82E-06	6.29E-07	2.47E-07	5.20E-07	0.00E+00	1.29E-04	9.13E-06
Te-127m	6.72E-06	2.31E-06	8.16E-07	1.64E-06	1.72E-05	4.00E-04	1.93E-05
Te-127	7.49E-10	2.57E-10	1.65E-10	5.30E-10	1.91E-09	2.71E-06	1.52E-05
Te-129m	5.19E-06	1.85E-06	8.22E-07	1.71E-06	1.36E-05	4.76E-04	4.91E-05
Te-129	2.64E-11	9.45E-12	6.44E-12	1.93E-11	6.94E-11	7.93E-07	6.89E-06
Te-131m	3.63E-08	1.60E-08	1.37E-08	2.64E-08	1.08E-07	5.56E-05	8.32E-05
Te-131	5.87E-12	2.28E-12	1.78E-12	4.59E-12	1.59E-11	5.55E-07	3.60E-07
Te-132	1.30E-07	7.36E-08	7.12E-08	8.58E-08	4.79E-07	1.02E-04	3.72E-05
I-130	2.21E-06	4.43E-06	2.28E-06	4.99E-04	6.61E-06	0.00E+00	1.38E-06
I-131	1.30E-05	1.30E-05	7.37E-06	4.39E-03	2.13E-05	0.00E+00	7.68E-07
I-132	5.72E-07	1.10E-06	5.07E-07	5.23E-05	1.69E-06	0.00E+00	8.65E-07
I-133	4.48E-06	5.49E-06	2.08E-06	1.04E-03	9.13E-06	0.00E+00	1.48E-06
I-134	3.17E-07	5.84E-07	2.69E-07	1.37E-05	8.92E-07	0.00E+00	2.58E-07
I-135	1.33E-06	2.36E-06	1.12E-06	2.14E-04	3.62E-06	0.00E+00	1.20E-06
Cs-134	1.76E-04	2.74E-04	6.07E-05	0.00E+00	8.93E-05	3.27E-05	1.04E-06
Cs-136	1.76E-05	4.62E-05	3.14E-05	0.00E+00	2.58E-05	3.93E-06	1.13E-06
Cs-137	2.45E-04	2.23E-04	3.47E-05	0.00E+00	7.63E-05	2.81E-05	9.78E-07
Cs-138	1.71E-07	2.27E-07	1.50E-07	0.00E+00	1.68E-07	1.84E-08	7.29E-08
Ba-139	4.98E-10	2.66E-13	1.45E-11	0.00E+00	2.33E-13	1.56E-06	1.56E-05
Ba-140	2.00E-05	1.75E-08	1.17E-06	0.00E+00	5.71E-09	4.71E-04	2.75E-05
Ba-141	5.29E-11	2.95E-14	1.72E-12	0.00E+00	2.56E-14	7.89E-07	7.44E-08
Ba-142	1.35E-11	9.73E-15	7.54E-13	0.00E+00	7.87E-15	4.44E-07	7.41E-10
La-140	1.74E-07	6.08E-08	2.04E-08	0.00E+00	0.00E+00	4.94E-05	6.10E-05
La-142	3.50E-10	1.11E-10	3.49E-11	0.00E+00	0.00E+00	2.35E-06	2.05E-05
Ce-141	1.06E-05	5.28E-06	7.83E-07	0.00E+00	2.31E-06	1.47E-04	1.53E-05
Ce-143	9.89E-08	5.37E-08	7.77E-09	0.00E+00	2.26E-08	3.12E-05	3.44E-05
Ce-144	1.83E-03	5.72E-04	9.77E-05	0.00E+00	3.17E-04	3.23E-03	1.05E-04
Pr-143	4.99E-06	1.50E-06	2.47E-07	0.00E+00	8.11E-07	1.17E-04	2.63E-05
Pr-144	1.61E-11	4.99E-12	8.10E-13	0.00E+00	2.64E-12	4.23E-07	5.32E-08
Nd-147	2.92E-06	2.36E-06	1.84E-07	0.00E+00	1.30E-06	8.87E-05	2.22E-05
W-187	4.41E-09	2.61E-09	1.17E-09	0.00E+00	0.00E+00	1.11E-05	2.46E-05
Np-239	1.26E-07	9.04E-09	6.35E-09	0.00E+00	2.63E-08	1.57E-05	1.73E-05

Reference:

Dose Factors for Co-57, Zn-69m, Br-82, Nb-97, Sb-124, Sb-125 are from Reference 17, Table 8.
All others from: Regulatory Guide 1.109, Table E-9.

NOTE: The tritium dose factor for bone is assumed to be equal to the total body dose factor. This assumes that tritium will act similarly in all organs (Reference 24).

Table 7.7 - INHALATION DOSE FACTORS - DF_{Ino}

(mrem/pCi inhaled)

(Page 7 of 8)

INFANT

Nuclide	bone	liver	total body	thyroid	kidney	lung	GI-LLI
H-3	4.62E-07	4.62E-07	4.62E-07	4.62E-07	4.62E-07	4.62E-07	4.62E-07
C-14	1.89E-05	3.79E-06	3.79E-06	3.79E-06	3.79E-06	3.79E-06	3.79E-06
Na-24	7.54E-06	7.54E-06	7.54E-06	7.54E-06	7.54E-06	7.54E-06	7.54E-06
P-32	1.45E-03	8.03E+05	5.53E-05	0.00E+00	0.00E+00	0.00E+00	1.15E-05
Cr-51	0.00E+00	0.00E+00	6.39E-08	4.11E-08	9.45E-09	9.17E-06	2.55E-07
Mn-54	0.00E+00	1.81E-05	3.56E-06	0.00E+00	3.56E-06	7.14E-04	5.04E-06
Mn-56	0.00E+00	1.10E-09	1.58E-10	0.00E+00	7.86E-10	8.95E-06	5.12E-05
Fe-55	1.41E-05	8.39E-06	2.38E-06	0.00E+00	0.00E+00	6.21E-05	7.82E-07
Fe-59	9.69E-06	1.68E-05	6.77E-06	0.00E+00	0.00E+00	7.25E-04	1.77E-05
Co-57	0.00E+00	4.65E-07	4.58E-07	0.00E+00	0.00E+00	2.71E-04	3.47E-06
Co-58	0.00E+00	8.71E-07	1.30E-06	0.00E+00	0.00E+00	5.55E-04	7.95E-06
Co-60	0.00E+00	5.73E-06	8.41E-06	0.00E+00	0.00E+00	3.22E-03	2.28E-05
Ni-63	2.42E-04	1.46E-05	8.29E-06	0.00E+00	0.00E+00	1.49E-04	1.73E-06
Ni-65	1.71E-09	2.03E-10	8.79E-11	0.00E+00	0.00E+00	5.80E-06	3.58E-05
Cu-64	0.00E+00	1.34E-09	5.53E-10	0.00E+00	2.84E-09	6.64E-06	1.07E-05
Zn-65	1.38E-05	4.47E-05	2.22E-05	0.00E+00	2.32E-05	4.62E-04	3.67E-05
Zn-69	3.85E-11	6.91E-11	5.13E-12	0.00E+00	2.87E-11	1.05E-06	9.44E-06
Zn-69m	8.98E-09	1.84E-08	1.67E-09	0.00E+00	7.45E-09	1.91E-05	2.92E-05
Br-82	0.00E+00	0.00E+00	9.49E-06	0.00E+00	0.00E+00	0.00E+00	0.00E+00
Br-83	0.00E+00	0.00E+00	2.72E-07	0.00E+00	0.00E+00	0.00E+00	0.00E+00
Br-84	0.00E+00	0.00E+00	2.86E-07	0.00E+00	0.00E+00	0.00E+00	0.00E+00
Br-85	0.00E+00	0.00E+00	1.46E-08	0.00E+00	0.00E+00	0.00E+00	0.00E+00
Rb-86	0.00E+00	1.36E-04	6.30E-05	0.00E+00	0.00E+00	0.00E+00	2.17E-06
Rb-88	0.00E+00	3.98E-07	2.05E-07	0.00E+00	0.00E+00	0.00E+00	2.42E-07
Rb-89	0.00E+00	2.29E-07	1.47E-07	0.00E+00	0.00E+00	0.00E+00	4.87E-08
Sr-89	2.84E-04	0.00E+00	8.15E-06	0.00E+00	0.00E+00	1.45E-03	4.57E-05
Sr-90	2.92E-02	0.00E+00	1.85E-03	0.00E+00	0.00E+00	8.03E-03	9.36E-05
Sr-91	6.83E-08	0.00E+00	2.47E-09	0.00E+00	0.00E+00	3.76E-05	5.24E-05
Sr-92	7.50E-09	0.00E+00	2.79E-10	0.00E+00	0.00E+00	1.70E-05	1.00E-04
Y-90	2.35E-06	0.00E+00	6.30E-08	0.00E+00	0.00E+00	1.92E-04	7.43E-05
Y-91m	2.91E-10	0.00E+00	9.90E-12	0.00E+00	0.00E+00	1.99E-06	1.68E-06
Y-91	4.20E-04	0.00E+00	1.12E-05	0.00E+00	0.00E+00	1.75E-03	5.02E-05
Y-92	1.17E-08	0.00E+00	3.29E-10	0.00E+00	0.00E+00	1.75E-05	9.04E-05
Y-93	1.07E-07	0.00E+00	2.91E-09	0.00E+00	0.00E+00	5.46E-05	1.19E-04
Zr-95	8.24E-05	1.99E-05	1.45E-05	0.00E+00	2.22E-05	1.25E-03	1.55E-05
Zr-97	1.07E-07	1.83E-08	8.36E-09	0.00E+00	1.85E-08	7.88E-05	1.00E-04
Nb-95	1.12E-05	4.59E-06	2.70E-06	0.00E+00	3.37E-06	3.42E-04	9.05E-06
Nb-97	2.44E-10	5.21E-11	1.88E-11	0.00E+00	4.07E-11	2.37E-06	1.92E-05
Mo-99	0.00E+00	1.18E-07	2.31E-08	0.00E+00	1.89E-07	9.63E-05	3.48E-05
Tc-99m	9.98E-13	2.06E-12	2.66E-11	0.00E+00	2.22E-11	5.79E-07	1.45E-06
Tc-101	4.65E-14	5.88E-14	5.80E-13	0.00E+00	6.99E-13	4.17E-07	6.03E-07
Ru-103	1.44E-06	0.00E+00	4.85E-07	0.00E+00	3.03E-06	3.94E-04	1.15E-05
Ru-105	8.74E-10	0.00E+00	2.93E-10	0.00E+00	6.42E-10	1.12E-05	3.46E-05
Ru-106	6.20E-05	0.00E+00	7.77E-06	0.00E+00	7.61E-05	8.26E-03	1.17E-04

Table 7.7 - INHALATION DOSE FACTORS - DF_{iao}
(mrem/pCi inhaled)
(page 8 of 8)
INFANT

Nuclide	bone	liver	total body	thyroid	kidney	lung	GI-LLI
Ag-110m	7.13E-06	5.16E-06	3.57E-06	0.00E+00	7.80E-06	2.62E-03	2.36E-05
Sb-124	2.71E-05	3.97E-07	8.56E-06	7.18E-08	0.00E+00	1.89E-03	4.22E-05
Sb-125	3.69E-05	3.41E-07	7.78E-06	4.45E-08	0.00E+00	1.17E-03	1.05E-05
Te-125m	3.40E-06	1.42E-06	4.70E-07	1.16E-06	0.00E+00	3.19E-04	9.22E-06
Te-127m	1.19E-05	4.93E-06	1.48E-06	3.48E-06	2.68E-05	9.37E-04	1.95E-05
Te-127	1.59E-09	6.81E-10	3.49E-10	1.32E-09	3.47E-09	7.39E-06	1.74E-05
Te-129m	1.01E-05	4.35E-06	1.59E-06	3.91E-06	2.27E-05	1.20E-03	4.93E-05
Te-129	5.63E-11	2.48E-11	1.34E-11	4.82E-11	1.25E-10	2.14E-06	1.88E-05
Te-131m	7.62E-08	3.93E-08	2.59E-08	6.38E-08	1.89E-07	1.42E-04	8.51E-05
Te-131	1.24E-11	5.87E-12	3.57E-12	1.13E-11	2.85E-11	1.47E-06	5.87E-06
Te-132	2.66E-07	1.69E-07	1.26E-07	1.99E-07	7.39E-07	2.43E-04	3.15E-05
I-130	4.54E-06	9.91E-06	3.98E-06	1.14E-03	1.09E-05	0.00E+00	1.42E-06
I-131	2.71E-05	3.17E-05	1.40E-05	1.06E-02	3.70E-05	0.00E+00	7.56E-07
I-132	1.21E-06	2.53E-06	8.99E-07	1.21E-04	2.82E-06	0.00E+00	1.36E-06
I-133	9.46E-06	1.37E-05	4.00E-06	2.54E-03	1.60E-05	0.00E+00	1.54E-06
I-134	6.58E-07	1.34E-06	4.75E-07	3.18E-05	1.49E-06	0.00E+00	9.21E-07
I-135	2.76E-06	5.43E-06	1.98E-06	4.97E-04	6.05E-06	0.00E+00	1.31E-06
Cs-134	2.83E-04	5.02E-04	5.32E-05	0.00E+00	1.36E-04	5.69E-05	9.53E-07
Cs-136	3.45E-05	9.61E-05	3.78E-05	0.00E+00	4.03E-05	8.40E-06	1.02E-06
Cs-137	3.92E-04	4.37E-04	3.25E-05	0.00E+00	1.23E-04	5.09E-05	9.53E-07
Cs-138	3.61E-07	5.58E-07	2.84E-07	0.00E+00	2.93E-07	4.67E-08	6.26E-07
Ba-139	1.06E-09	7.03E-13	3.07E-11	0.00E+00	4.23E-13	4.25E-06	3.64E-05
Ba-140	4.00E-05	4.00E-08	2.07E-06	0.00E+00	9.59E-09	1.14E-03	2.74E-05
Ba-141	1.12E-10	7.70E-14	3.55E-12	0.00E+00	4.64E-14	2.12E-06	3.39E-06
Ba-142	2.84E-11	2.36E-14	1.40E-12	0.00E+00	1.36E-14	1.11E-06	4.95E-07
La-140	3.61E-07	1.43E-07	3.68E-08	0.00E+00	0.00E+00	1.20E-04	6.06E-05
La-142	7.36E-10	2.69E-10	6.46E-11	0.00E+00	0.00E+00	5.87E-06	4.25E-05
Ce-141	1.98E-05	1.19E-05	1.42E-06	0.00E+00	3.75E-06	3.69E-04	1.54E-05
Ce-143	2.09E-07	1.38E-07	1.58E-08	0.00E+00	4.03E-08	8.30E-05	3.55E-05
Ce-144	2.28E-03	8.65E-04	1.26E-04	0.00E+00	3.84E-04	7.03E-03	1.06E-04
Pr-143	1.00E-05	3.74E-06	4.99E-07	0.00E+00	1.41E-06	3.09E-04	2.66E-05
Pr-144	3.42E-11	1.32E-11	1.72E-12	0.00E+00	4.80E-12	1.15E-06	3.06E-06
Nd-147	5.67E-06	5.81E-06	3.57E-07	0.00E+00	2.25E-06	2.30E-04	2.23E-05
W-187	9.26E-09	6.44E-09	2.23E-09	0.00E+00	0.00E+00	2.83E-05	2.54E-05
Np-239	2.65E-07	2.37E-08	1.34E-08	0.00E+00	4.73E-08	4.25E-05	1.78E-05

Reference:

Dose Factors for Co-57, Zn-69m, Br-82, Nb-97, Sb-124, Sb-125 are from Reference 17, Table 8.
All others from: Regulatory Guide 1.109, Table E-10.

NOTE: The tritium dose factor for bone is assumed to be equal to the total body dose factor. This assumes that tritium will act similarly in all organs (Reference 24).

Figure 7.1 - GASEOUS EFFLUENT RELEASE/DISCHARGE POINTS

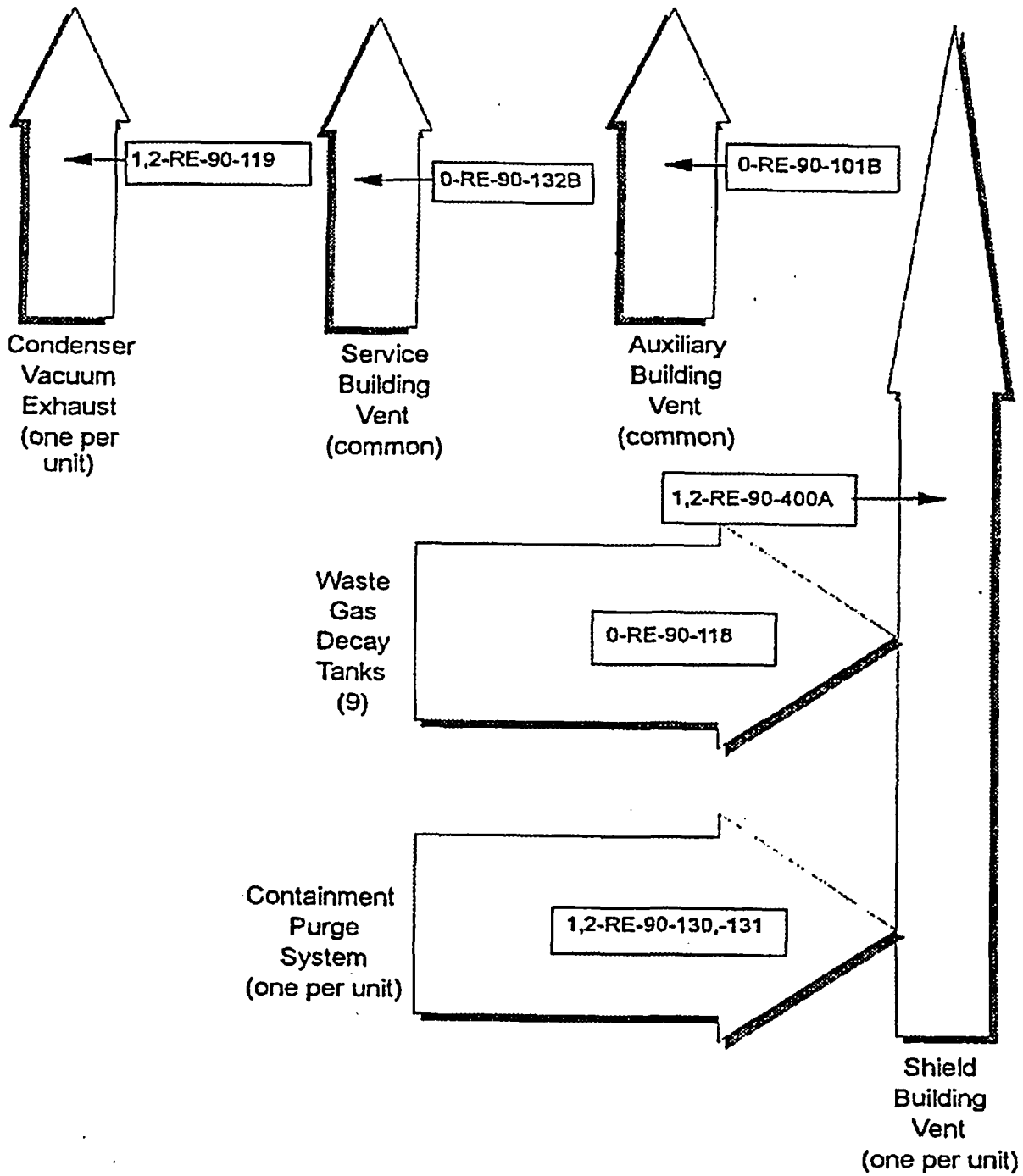

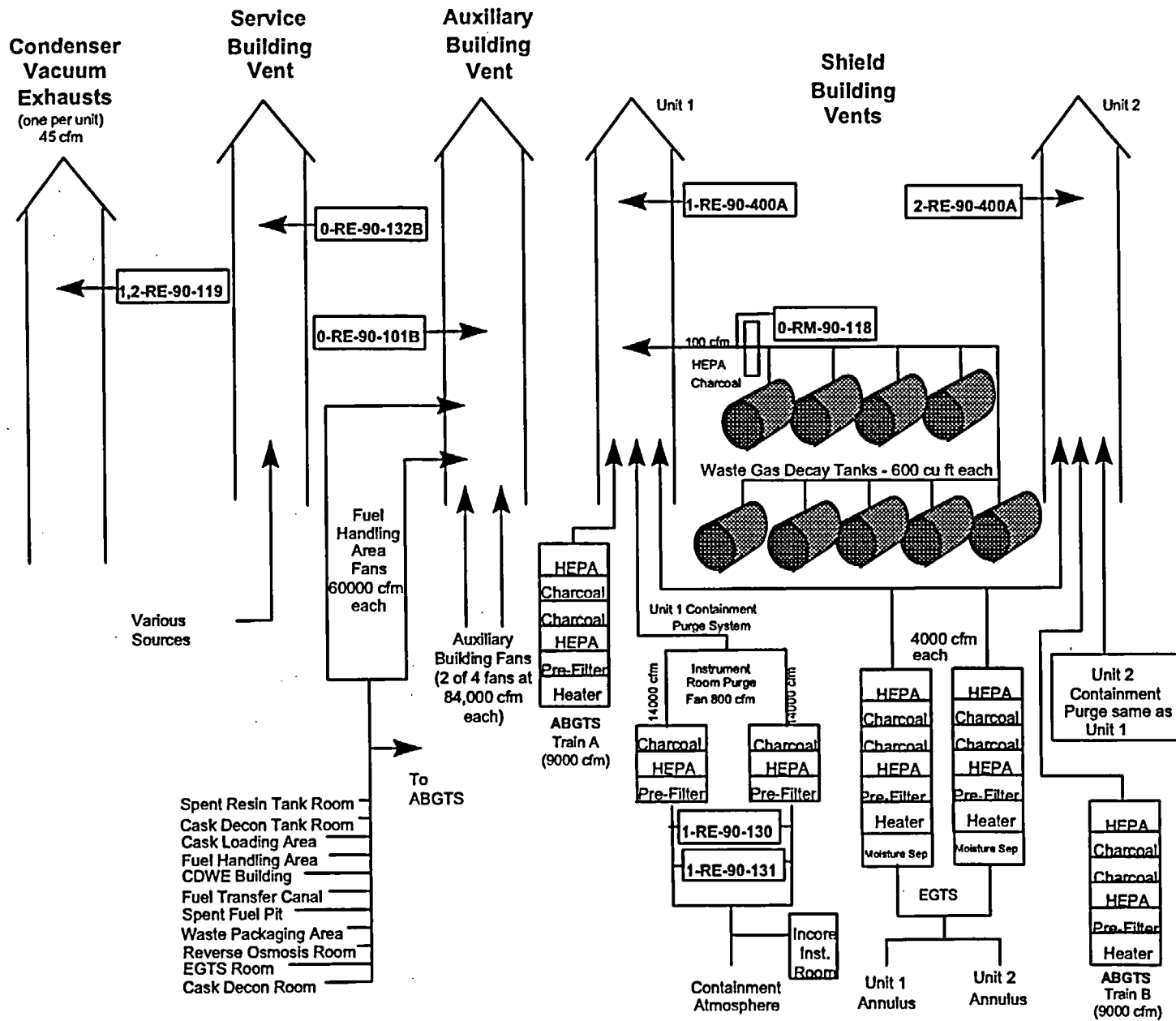

Figure 7.2 - DETAIL OF GASEOUS RELEASE/DISCHARGE POINTS

Figure 7.3 - GASEOUS RADWASTE TREATMENT SYSTEM

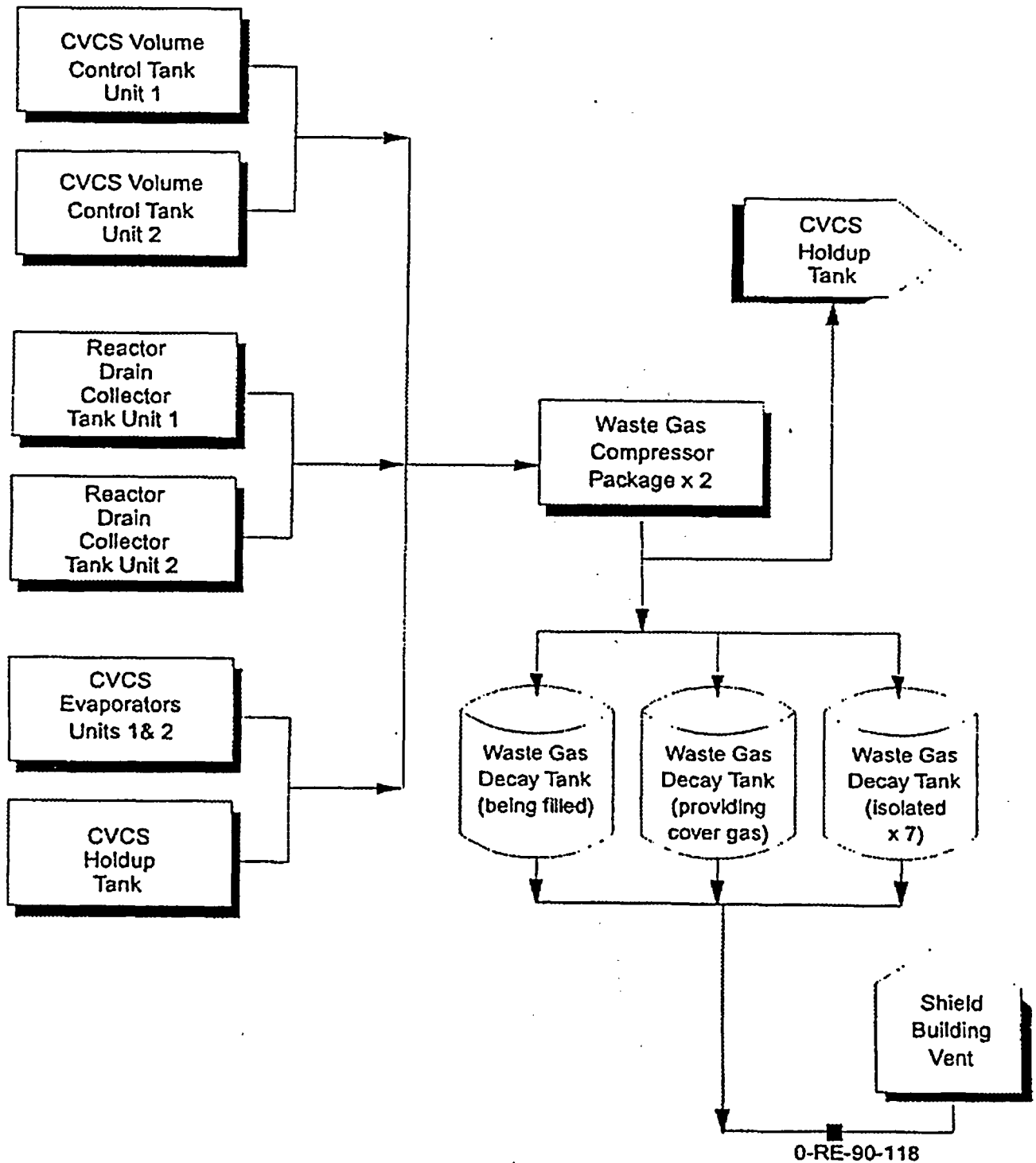
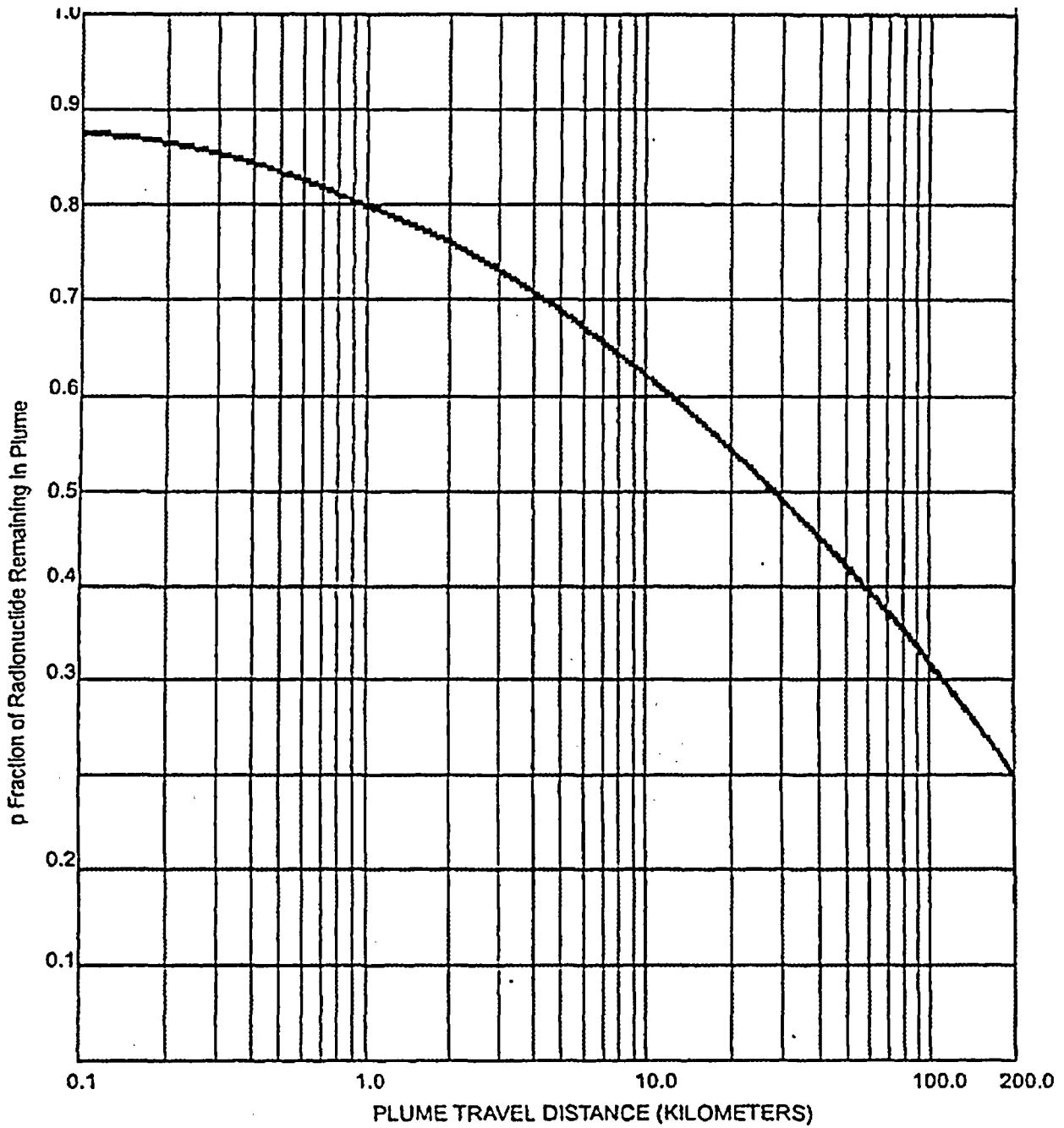
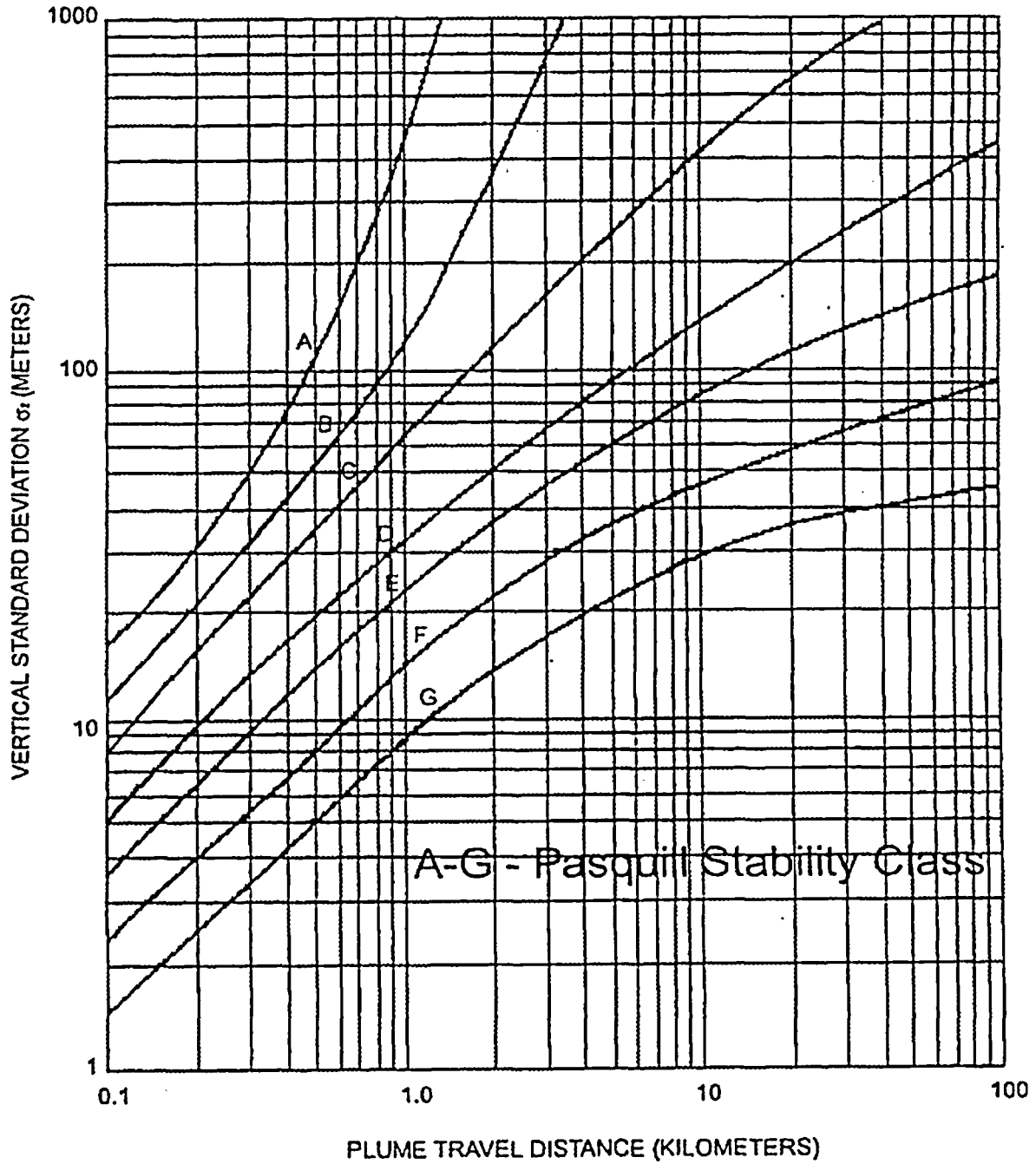

Figure 7.4 - PLUME DEPLETION EFFECT FOR GROUND LEVEL RELEASES
(All Stability Classes)



Source: Reference 5, Figure 2

Figure 7.5 - VERTICAL STANDARD DEVIATION OF MATERIAL IN A PLUME



Source: Reference 5, Figure 1

Figure 7.6 - RELATIVE DEPOSITION FOR GROUND LEVEL RELEASES
(All Stability Classes)

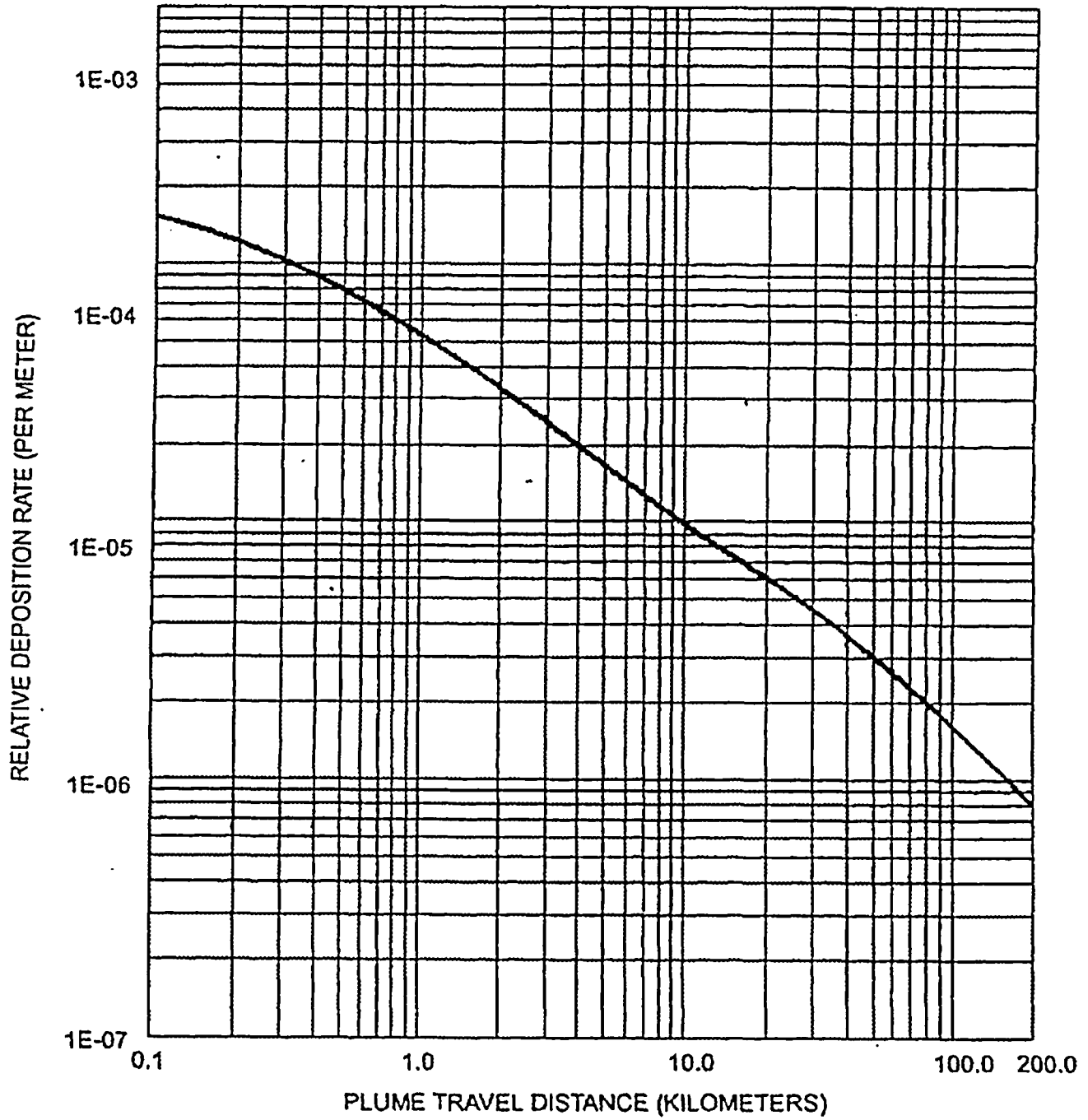

Source: Reference 5, Figure 6

8.0 - TOTAL DOSE

8.1 TOTAL MAXIMUM INDIVIDUAL DOSES

To determine compliance with 40 CFR 190 as required in ODCM Surveillance Requirement 2.2.3.1 and 2.2.3.2, the dose contributions to the maximum individual from WBN radioactive effluents and all other nearby uranium fuel cycle sources will be considered. The annual dose to the maximum individual will be conservatively estimated by using the following equation:

$$D = \sum_{q=1}^4 D(\text{airtb}) + D(\text{airorg}) + D(\text{liqtb}) + D(\text{liqorg}) + D(\text{direct}) \quad (8.1)$$

where:

q = calendar quarter

D(airtb) = the total body air submersion dose (as calculated in Section 7.7)

D(airorg) = the critical organ dose from gaseous effluents (as calculated in Section 7.7),

D(liqtb) = the total body dose from liquid effluents (as calculated in Section 6.6.4),

D(liqorg) = the critical organ dose from liquid effluents (as calculated in Section 6.6.4),

D(direct) = the direct radiation dose measured by the environmental monitoring program.

The dose calculated is compared to the total body/organ limit of 25 mrem. If the dose is greater than 25 mrem, then the dose to each individual organ will be evaluated separately for comparison to the limits.

9.0 - RADIOLOGICAL ENVIRONMENTAL MONITORING PROGRAM (REMP)

9.1 MONITORING PROGRAM DESCRIPTION

The REMP shall be conducted in accordance with the requirements of ODCM Control 1.3.1. The monitoring program described in Tables 9.1, 9.2, and 9.3, and in Figures 9.1, 9.2 and 9.3 shall be conducted.

The program consists of 3 major sections corresponding to the atmospheric pathway, the terrestrial pathway, and the waterborne pathway. In the atmospheric monitoring program, samples of air particulates and atmospheric radiiodines are collected from established stations. The stations are identified as Local Monitor (LM) stations, located at or near the unrestricted area boundary; Perimeter Monitor (PM) stations, located typically 3-10 miles from the site; and Remote Monitor (RM) stations, located greater than 10 miles from the site. The remote monitors are considered as background or control stations.

The terrestrial monitoring program includes the collection of milk, soil, and food crops. In addition, direct gamma radiation levels will be measured in the vicinity of the plant.

The waterborne monitoring program consists of the collection of samples of surface and ground water, drinking water, sediment, and fish. Samples are collected both downstream and upstream from the plant site.

The basic description of the REMP is included in Tables 9.1 and 9.2. Table 9.3 describes the locations of the direct gamma radiation detectors (thermoluminescent detectors or TLDs). Figures 9.1, 9.2, and 9.3 show the locations of the stations within one mile of the site, between one and five miles from the site, and greater than 5 miles from the site, respectively.

Deviations are permitted from the required sampling schedule if specimens are unobtainable due to hazardous conditions, sample unavailability, or malfunction of sampling equipment. If the latter, every effort shall be made to complete corrective action prior to the end of the next sampling period. Deviations from the required program will be reported in the Annual Radiological Environmental Operating Report in accordance with the provisions of ODCM Control 1.3.1.a and Administrative Control 5.1. Changes made in the program resulting from unavailability of samples will be reported in accordance with ODCM Control 1.3.1.c.

9.2 DETECTION CAPABILITIES

Analytical techniques shall be such that the detection capabilities listed in Table 2.3-3 are achieved.

9.3 LAND USE CENSUS

A land use survey shall be conducted in accordance with the requirements given in ODCM Control 1.3.2. The results of the survey shall be reported in the Annual Radiological Environmental Operating Report. Changes made in the REMP as a result of the Land Use Census will be reported in accordance with the provisions of ODCM Control 1.3.2.b.

9.4 INTERLABORATORY COMPARISON PROGRAM

Analyses shall be performed on radioactive materials supplied as part of an Interlaboratory Comparison Program which has been approved by the NRC. A summary of the results obtained in the intercomparison shall be included in the Annual Radiological Environmental Operating Report (or the EPA program code designation may be provided).

If analyses are not performed as required corrective actions taken to prevent a recurrence shall be reported in the Annual Radiological Environmental Operating Report.

9.5 DATA REVIEW AND REPORTING

Results of this program shall be reported in accordance with ODCM Administrative Control 5.1, Annual Radiological Environmental Monitoring Report. Analytical results exceeding the reporting levels outlined in ODCM Table 2.3-2 will be reported in accordance with the requirements of ODCM Control 1.3.1.b. As noted in WBN FSAR Section 11.6, routine releases from WBN will result in environmental concentrations well below the detection limits for environmental media, making correlations between calculated effluent release data and environmental measurements impractical. Only if radioactive releases from the site result in statistically measurable increases in environmental levels can dose correlations be made.

Table 9.1 - REMP - MONITORING, SAMPLING, AND ANALYSIS
(Page 1 of 5)

Exposure Pathway and/or Sample	Sample Locations ¹	Sampling and Collection Frequency	Type and Frequency of Analysis
1. DIRECT RADIATION			
	<p>2 or more TLDs placed at locations (in different sectors) at or near the unrestricted area boundary in each of the 16 sectors.</p> <p>2 or more TLDs placed at stations located approximately 5 miles from the plant in each of the 16 sectors</p> <p>2 or more TLDs in at least 8 additional locations of special interest, including at least 2 control stations.</p>	Once per 92 days	Gamma dose at least once per 92 days

Table 9.1 - REMP - MONITORING, SAMPLING, AND ANALYSIS
(Page 2 of 5)

Exposure Pathway and/or Sample	Sample Locations ¹	Sampling and Collection Frequency	Type and Frequency of Analysis
2. AIRBORNE			
Particulates and Radioiodines	<p>4 samples from locations (in different sectors) at or near the unrestricted area boundary (LM-1,2,3,and 4)</p> <p>4 samples from communities approximately 6-10 miles distance from the plant. (PM-2,3,4,and 5)</p> <p>2 samples from control locations greater than 10 miles from the plant (RM-2 and 3)</p>	Continuous sampler operation with sample collection once per 7 days (more frequently if required by dust loading)	<p>Particulate samples: Analyze for gross beta radioactivity \geq 24 hours following filter change. Perform gamma isotopic analysis on each sample if gross beta > 10 times that of control sample.</p> <p>Composite at least once per 31 days (by location) for gamma scan.</p> <p>Radioiodine cartridge: I-131 at least once per 7 days</p>
Atmospheric Moisture	<p>4 samples from locations (in different sectors) at or near the site boundary (LM-1,2,3,and 4)</p> <p>2 samples from communities approximately 4-10 miles distance from the plant. (PM-2,5,)</p> <p>1 sample from control location greater than 10 miles from the plant (RM-3)</p>	Continuous sampler operation with sample collection biweekly	Analyze each sample for H-3
Soil	Samples from same location as air particulates.	Once per year	Gamma scan, Sr-89, Sr-90 once per year

Table 9.1 - REMP - MONITORING, SAMPLING, AND ANALYSIS
(Page 3 of 5)

Exposure Pathway and/or Sample	Sample Locations ¹	Sampling and Collection Frequency	Type and Frequency of Analysis
3. WATERBORNE			
Surface	TRM 529.3 TRM 523.1 TRM 517.9	Collected by automatic sequential-type sampler ² with composite samples collected at least once per 31 days	Gamma scan and H-3 analysis of each sample
Ground	5 sampling locations from ground water monitoring wells adjacent to plant 1 sampling location from groundwater source upgradient from the plant	Collected by automatic sequential-type sampler ² with composite samples collected at least once per 31 days	Gross beta, gamma scan, and H-3 analysis of each sample
Drinking	1 sample at the first potable surface water supply downstream from the plant (TRM 503.8) 1 sample at the next downstream potable surface water supplier (greater than 10 miles downstream) (TRM 473.0) 1 sample at control location ³ (TRM 529.3)	Collected by automatic sequential type sampler ² with composite sample collected at least once per 31 days	Gross beta, gamma scan, and H-3 analysis of each sample
Shoreline	TRM 513, TRM 530.2	At least once per 184 days	Gamma scan of each sample.
Pond Sediment	One sample from at least three locations in Yard Holding Pond.	Annually	Gamma scan of each sample.

Table 9.1 - REMP - MONITORING, SAMPLING, AND ANALYSIS
(Page 4 of 5)

Exposure Pathway and/or Sample	Sample Locations ¹	Sampling and Collection Frequency	Type and Frequency of Analysis
4. INGESTION			
Milk	<p>1 sample from milk producing animals in each of 1-3 areas indicated by the cow census where doses are calculated to be highest. If samples are not available from a milk animal location, doses to that area may be estimated by projecting the doses from concentrations detected in milk from other sectors or samples of vegetation may be taken monthly where milk is produced but is not available.</p> <p>At least 1 sample from a control location</p>	At least once per 15 days	Gamma isotopic and I-131 analysis of each sample. Sr-89, Sr-90 once per quarter
Fish	One sample of commercially important species and one sample of recreationally important species. One sample of each species from Chickamauga and Watts Bar Reservoirs.	At least once per 184 days.	Gamma scan on edible portion.
Food Products	1 sample each of principal food products grown at private gardens and/or farms in the vicinity of the plant.	<p>At least once per 365 days at the time of harvest. The types of foods available will vary. Following is a list of typical foods which may be available:</p> <p>Cabbage and/or Lettuce Corn Green Beans Potatoes Tomatoes</p>	Gamma scan on edible portion.

Table 9.1 - REMP - MONITORING, SAMPLING, AND ANALYSIS
(Page 5 of 5)

Exposure Pathway and/or Sample	Sample Locations ¹	Sampling and Collection Frequency	Type and Frequency of Analysis
Vegetation ⁴	Samples from farms producing milk but not providing a milk sample	At least once per 31 days	I-131 and gamma scan at least once per 31 days.

¹ Sample locations are listed in Tables 9.2 and 9.3 and shown on Figures 9.1, 9.2 and 9.3.

² Samples shall be collected by collecting an aliquot at intervals not exceeding 2 hours.

³ The surface water sample collected at TRM 529.3 is considered a control for the raw drinking water sample.

⁴ Vegetation sampling is applicable only for farms that meet the criteria for milk sampling and when milk sampling cannot be performed.

Other Notes: LM = Local Monitor
PM = Perimeter Monitor
RM = Remote Monitor
TRM = Tennessee River Mile

Table 9.2 - REMP - SAMPLING LOCATIONS

Map Location Number	Station ^a	Sector	Approximate Distance (ml)	Indicator (I) or Control(C)	Samples Collected ^b
2	PM-2	NW	7.0	I	AP, CF, S, AM
3	PM-3	NNE	10.4	I	AP, CF, S
4	PM-4	NE/ENE ^c	7.6	I	AP, CF, S
5	PM-5	S	8.0	I	AP, CF, S, AM
6	RM-2	SW	15.0	C	AP, CF, S
7	RM-3	NNW	15.0	C	AP, CF, S, AM
8	LM-1	SSW	0.5	I	AP, CF, S, AM
9	LM-2	NNE	0.4	I	AP, CF, S, AM
10	LM-3	NNE	1.9	I	AP, CF, S, AM
11	LM-4	SE	0.9	I	AP, CF, S, AM
12	Farm L	SSW	1.3	I ^d	M, V, W
15	Farm B	E	15.0	C	M
18	Well #1	S	0.6	I	W
19	Farm Mu	ESE	3.7	I	M
20	Farm N	ESE	4.1	I	M
22	Farm EH	SSW	24.0	C	M
23	Well#5	N	0.5	C	W
25	TRM 517.9	-	9.9 ^e	I	SW
26	TRM 523.1	-	4.7 ^e	I	SW
27	TRM 529.3	-	1.5 ^e	C	SW, PW ^f
31	TRM 473.0 (C.F. Industries)	-	54.8 ^e	I	PW
32	TRM 513.0	-	14.8 ^e	I	SS
33	TRM 530.2	-	2.4 ^e	C	SS
35	TRM 503.8 (Dayton)	-	24.0 ^e	I	PW
38	TRM 471-530 (Chickamauga Lake)	-	-	I	F
39	TRM 530-602 (Watts Bar Lake)	-	-	C	F
81	Yard Pond	SSE/S/SSW	Onsite	I	PS
82	Well A	SSE	0.6	I	W
83	Well B	SSE	0.5	I	W
84	Well C	ESE	0.3	I	W
85	Well D	SSE	0.4	I	W

^a See Figures 9.1, 9.2, and 9.3

^b Sample codes: AP = Air particulate filter; CF = Charcoal Filter; F = Fish; S = Soil; AM = atmospheric moisture, M = Milk; PW = Public Water; V = Vegetation; SS = Shoreline Sediment; SW = Surface Water; W = Well Water, PS = Pond Sediment

^c Station located on boundary between these sectors

^d A control for well water

^e Distance from plant discharge (TRM 527.8)

f The surface water sample from TRM 529.3 is also considered a control for raw Public Water samples.

Table 9.3 - REMP - THERMOLUMINESCENT DOSIMETRY LOCATIONS

Map Location Number	Station	Sector	Approx. Dist. (mi)	On/ Offsite ^a	Map Location Number	Station	Sector	Approx. Dist. (mi)	On/ Offsite ^a
2	NW-3	NW	7.0	Off	55	SSE-1A	SSE	0.6	On
3	NNE-3	NNE	10.4	Off	56	SSE-2	SSE	5.8	Off
4	ENE-3	ENE	7.6	Off	57	S-1	S	0.7	On
5	S-3	S	7.8	Off	58	S-2	S	4.8	Off
6	SW-3	SW	15.0	Off	59	SSW-1	SSW	0.8	On
7	NNW-4	NNW	15.0	Off	60	SSW-3	SSW	5.0	Off
10	NNE-1A	NNE	1.9	On	62	SW-1	SW	0.8	On
11	SE-1A	SE	0.9	On	63	SW-2	SW	5.3	Off
12	SSW-2	SSW	1.3	On	64	WSW-1	WSW	0.9	On
14	W-2	W	4.8	Off	65	WSW-2	WSW	3.9	Off
15	E-3	E	15.0	Off	66	W-1	W	0.9	On
40	N-1	N	1.2	On	67	WNW-1	WNW	0.9	On
41	N-2	N	4.7	Off	68	WNW-2	WNW	4.9	Off
42	NNE-1	NNE	1.2	On	69	NW-1	NW	1.1	On
43	NNE-2	NNE	4.1	Off	70	NW-2	NW	4.7	Off
44	NE-1	NE	0.9	On	71	NNW-1	NNW	1.0	On
45	NE-2	NE	2.9	Off	72	NNW-2	NNW	4.5	Off
46	NE-3	NE	6.1	Off	73	NNW-3	NNW	7.0	Off
47	ENE-1	ENE	0.7	On	74	ENE-2A	ENE	3.5	Off
48	ENE-2	ENE	5.8	Off	75	SE-2A	SE	3.1	Off
49	E-1	E	1.3	On	76	S-2A	S	2.0	Off
50	E-2	E	5.0	Off	77	W-2A	W	3.2	Off
51	ESE-1	ESE	1.2	On	78	NW-2A	NW	3.0	Off
52	ESE-2	ESE	4.4	Off	79	SSE-1	SE	0.5	On
54	SE-2	SE	5.3	Off					

^a TLDs designated onsite (On) are those located two miles or less from the plant. TLDs designated offsite (Off) are those located more than two miles from the plant.

Figure 9.1 - REMP LOCATIONS WITHIN ONE MILE OF THE PLANT

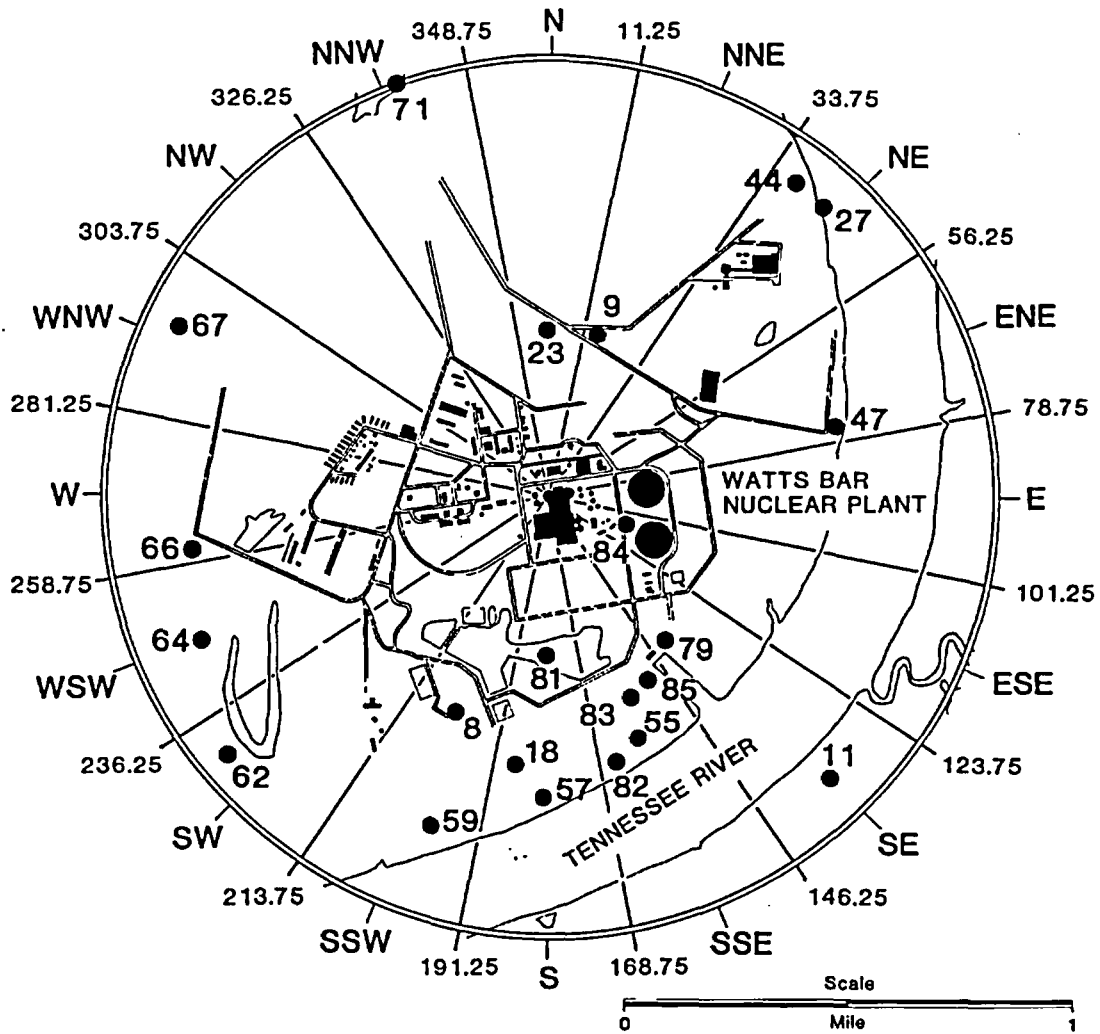

Figure 9.2 - REMP LOCATIONS FROM ONE TO FIVE MILES FROM THE PLANT

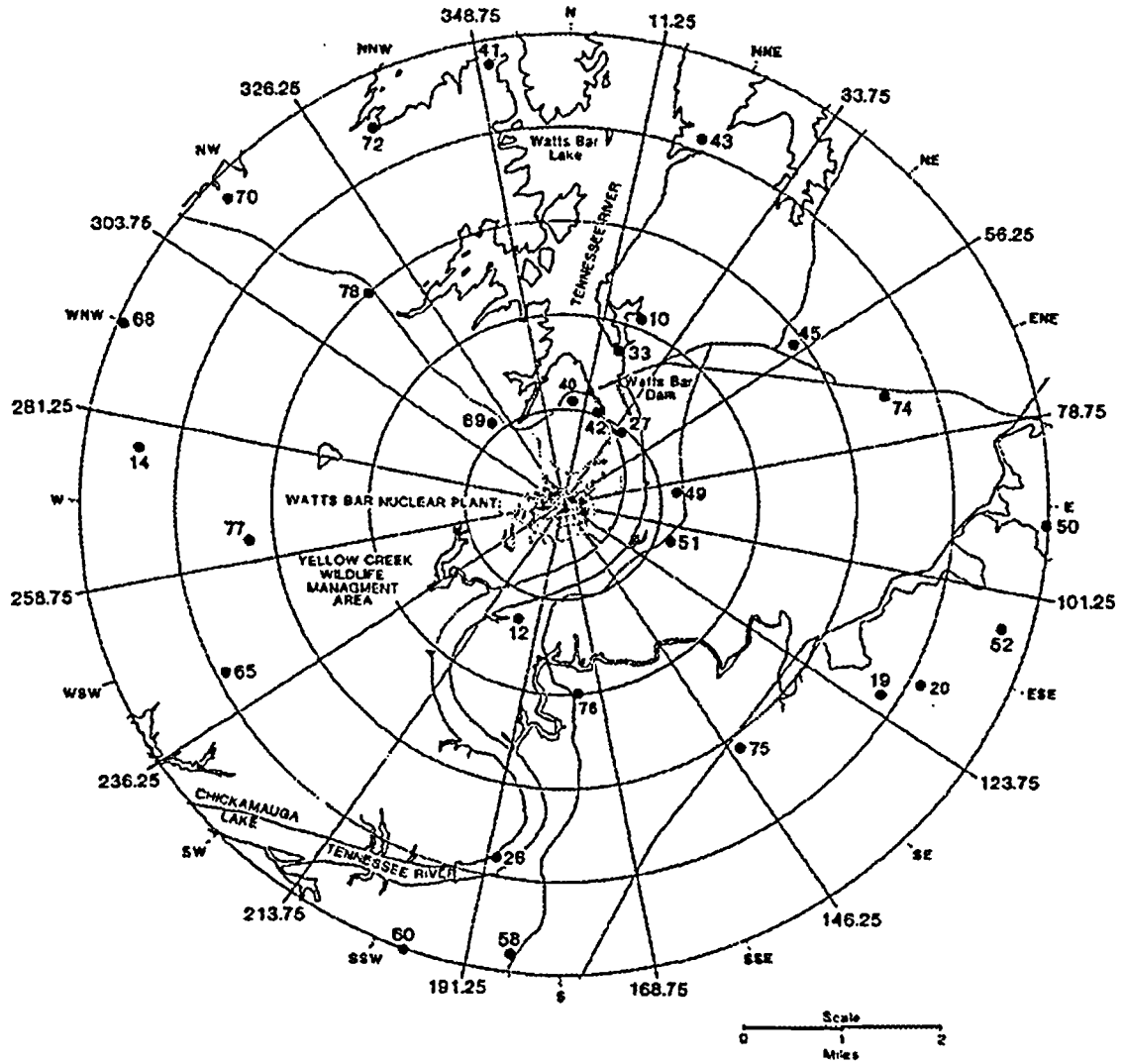
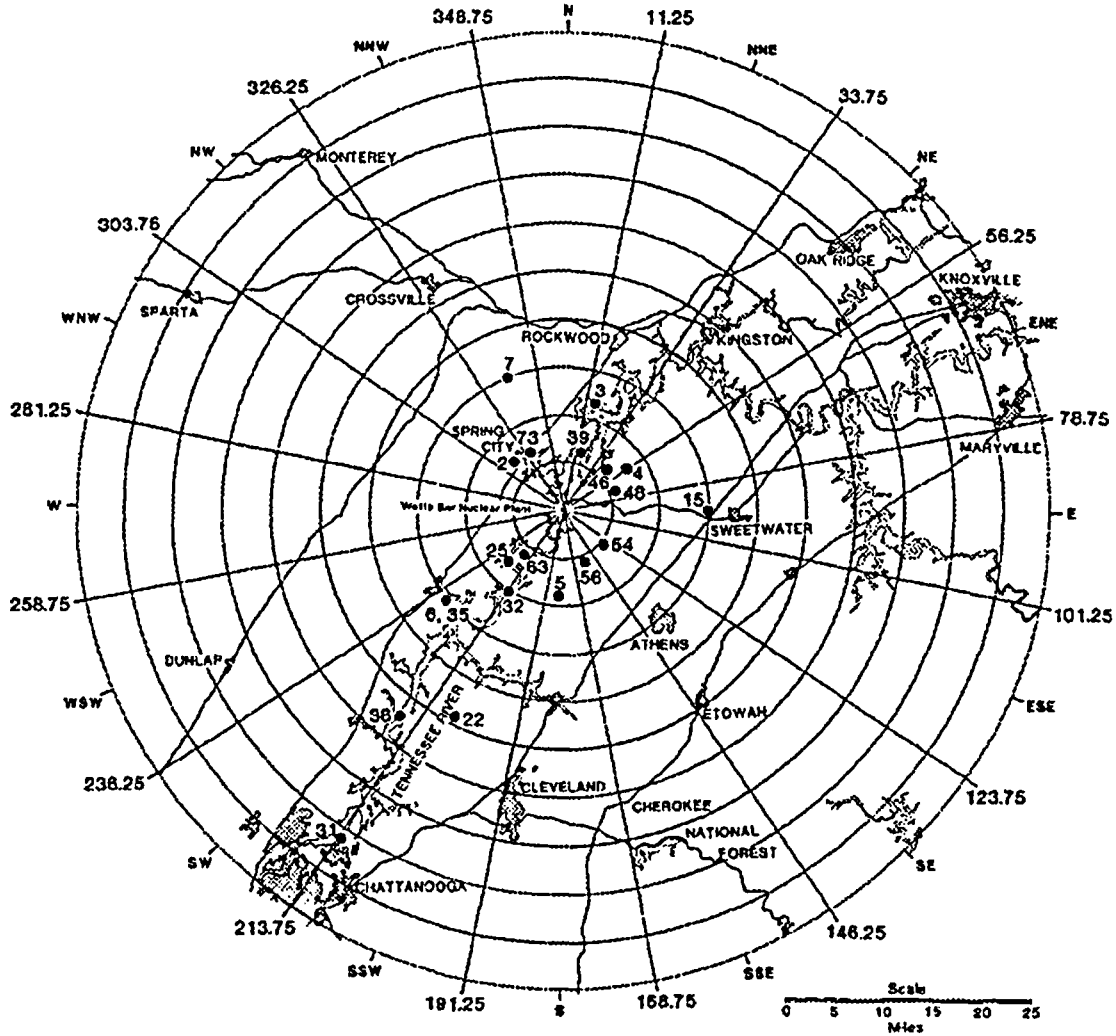

Figure 9.3 - REMP LOCATIONS GREATER THAN FIVE MILES FROM THE PLANT



10.0 REFERENCES

1. NUREG-1301, "Offsite Dose Calculation Manual Guidance: Standard Radiological Effluent Controls for Pressurized Water Reactors," Generic Letter 89-01, Supplement No. 1. April 1991.
2. Draft NRC Generic Letter, "Guidance for Modification of Technical Specifications to Reflect (a) Revisions to 10 CFR Part 20, 'Standards for Protection Against Radiation' and 10 CFR 50.36a, 'Technical Specifications on Effluents from Nuclear Power Reactors', (b) Related Current Industry Initiatives and (c) Miscellaneous Related Editorial Clarifications."
3. NUREG-0133, "Preparation of Radiological Effluent Technical Specifications for Nuclear Power Plants," September 1978.
4. Regulatory Guide 1.109, "Calculation of Annual Doses to Man from Routine Releases of Reactor Effluents for the Purpose of Evaluating Compliance with 10 CFR Part 50, Appendix I," Revision 1, October 1977.
5. Regulatory Guide 1.111, "Methods for Estimating Atmospheric Transport and Dispersion of Gaseous Effluents in Routine Releases from Light-Water-Cooled Reactors," Revision 1, July 1977.
6. Regulatory Guide 1.113, "Estimating Aquatic Dispersion of Effluents from Accidental and Routine Reactor Releases for the Purpose of Implementing 10 CFR Part 50 Appendix I," Revision 1, April 1977.
7. Regulatory Guide 1.21, "Measuring, Evaluating, and Reporting Radioactivity in Solid Wastes and Releases of Radioactive Materials in Liquid and Gaseous Effluents from Light-Water-Cooled Reactors," Revision 1, June 1974.
8. Radiological Assessment Branch Technical Position on Environmental Monitoring, Revision 1, November 1979.
9. WBN Final Environmental Statement, WBNP Units 1,2,3, Chattanooga, TN, November 9, 1972.
10. WBN Final Safety Analysis Report.
11. TVA Memorandum, E. E. Driver to R. B. Maxwell, "Watts Bar Nuclear Plant Dispersion," December 3, 1984.
12. TVA Memorandum, Edwin M. Scott to Betsy Eiford-Lee, "Fish Harvest Estimates for the Revision of the QWATA Computer Code," December 15, 1987.
13. TVA Memorandum, D. L. Stone to B. Eiford-Lee, "Surface area Computations for the Revision of the QWATA Code," April 26, 1988.
14. TVA Memorandum, R. A. Marker, "Revision to QWATA Computer Code," January 6, 1988.
15. DOE-TIC-11026, "Radioactive Decay Data Tables - A Handbook of Decay Data for Application to Radiation Dosimetry and Radiological Assessment," D. C. Kocher, 1981.

16. ORNL 4992, "Methodology for Calculating Radiation Doses from Radioactivity Released to the Environment," March 1976,.
17. NUREG-0172, "Age Specific Radiation Dose Commitment Factors for a One Year Chronic Intake," November 1977.
18. Dose-Rate Conversion Factors for External Exposure to Photon and Electron Radiation from Radionuclides Occurring in Routine Releases from Nuclear Fuel Cycle Facilities. D. C. Kocher, Health Physics Volume 38, April 1980.
19. TVA Memorandum, John P. Blackwell to M. L. Millinor, "Development of Atmospheric Dispersion Adjustment Factors for Application in the Watts Bar Nuclear Plant Offsite Dose Calculation Manual," November 16, 1990.
20. International Commission on Radiological Protection Publication 23, "Report of the Task Group on Reference Man," 1975.
21. NUREG/CR-1004, "A Statistical Analysis of Selected Parameters for Predicting Food Chain Transport and Internal Dose of Radionuclides," October 1979.
22. "Tennessee Valley Authority Effluent Management System (48-8434) Technical Reference Manual," Canberra Nuclear - Nuclear Data Systems Division, January 1994.
23. TVA Memorandum, M. S. Robinson to Radiological Hygiene Branch Files, "Cross-Sectional Areas of Nuclear Reactor Buildings," November 2, 1977.
24. Sequoyah Nuclear Plant Offsite Dose Calculation Manual.
25. TVA Quarterly Water Dose Assessment Computer Code Documentation, Revision 2.0, November 1989
26. TVA Memorandum, M. C. Brickey to M. E. Greeno, "Watts Bar Nuclear Plant Offsite Dose Calculation Manual - Changes Required - Revised agreements based on meeting between Nuclear Engineering and Chemistry on March 9, 1994," March 17, 1994
27. TVA Memorandum, Ed Steinhauer and Stan Nelson to Mike Greeno, "Offsite Dose Calculation Manual for Systems 14 and 15," February 10, 1994
28. TVA Memorandum, M. C. Brickey to Mike Greeno, "ODCM Change Request," March 3, 1995
29. NDP-00-0344, Revision 1, "Implementation and Utilization of Tritium Producing Burnable Absorber Rods (TPBARS) in Watts Bar Unit 1."

11.0 SOURCE NOTES

<u>SOURCE NOTE</u>	<u>Source Document</u>	<u>Summary</u>
1	NCO850192001	TVA response as described in NRC evaluation SER No. 5, Section 11.7, paragraph 4.
2	NRC IE Bulletin 82-49 SQN LER 50-327/92019	Adjust noble gas monitor setpoints based on chamber pressure.
3		Source Note deleted and calibration interval changed to 18 months per NE SSD 1-F-90-400A,B,C,D,-452 and 2-F-90-400C,-452.
4	NCO920030880	Specifications will ensure compliance with 10 CFR 50.34a (ALARA) and to ensure that concentrations of radioactive effluents released to unrestricted areas are within the limits specified in 10 CFR 20.106 (20.1301). The reporting requirements of 50.36a (a)(2) will also be included in these specifications.
5	NCO920042424	To ensure compliance with Radiological Effluent Tech Specs, cumulative dose calculations will be performed once per month.
6	NCO920042422	ODCM shall contain Radiological Environmental Monitoring Program sampling and analysis frequencies.
7	NCO920042500	Dose Calculations will be performed monthly to ensure that the dose rate in unrestricted areas due to gaseous effluents from the reactor at the site will be limited to the prescribed values.
8	NCO920042501	A complete analysis utilizing the total estimated liquid release for each calendar quarter will be performed and reported as required by Technical Specifications.
9	NCO920042502	Dose projections will be performed in accordance with Technical Specifications.
10	NCO920042423	Post-release analysis will be done using actual release data to ensure that limits were not exceeded. This data and setpoints will be recorded in auditable records by plant personnel.
11	WBPER960319	Operability requirements for Kurz isokinetic sampling panels will be added to the ODCM.

<u>SOURCE NOTE</u>	<u>Source Document</u>	<u>Summary</u>
13	WBPER970486 NCO970059002 NCO970059004	Added operability requirements for heat trace on iodine/particulate sample lines for Condenser Vacuum Exhaust and Shield Building Exhausts.
15	WBPER970492	Changed allowable monitor tolerance factor to 2.0 for gaseous monitor setpoint calculations.
16	WBPER971422	Changed submittal requirements to correspond to CFR requirements.
17	WBPER970332	Changed maximum design release flow rate for WGDT from 55 cfm to 100 cfm to reflect current design output.

APPENDIX A - NOTATION CONVENTIONS

(Page 1 of 7)

Symbol Key

This symbol key provides a cross-reference between the symbols used in the Watts Bar ODCM and those symbols used in the Regulatory Guidance documents for the ODCM (References 1, 2, 3, 4, and 5). The Watts Bar symbol is given, along with a definition of the term; then the reference document is given for that term, along with the corresponding symbol used in that reference.

Some terms may be subscripted in the WBN ODCM text and in the regulatory document. For simplification, no subscripts are included in this symbol key. The use of subscripts is standard throughout the WBN ODCM as follows:

subscript a: age group
 subscript i: radionuclide (T is used to denote tritium)
 subscript j: organ
 subscript k: windspeed category
 subscript l: Pasquill stability class
 subscript m: Public Water Supply or population element
 subscript P: dose pathway
 subscript r: river reach

WBN ODCM Symbol	Definition	Source Reference	Source Symbol
α	Minimum building cross-sectional area	R.G. 1.111 (p. 11)	D_z^2
A	Liquid dose factor	NUREG-0133 (p. 15)	A
a	Cumulative dose for a quarter	N/A	
ADC	Average decay correction	N/A	
AF	Allocation Fraction	N/A	
APR	Size of river reach	N/A	
A_F	Dose factor for fish ingestion	NUREG-0133 (p. 15)	
A_R	Dose factor for shoreline recreation	N/A	
ATMW	Ratio of average to maximum ingestion rates	N/A	
BKG	Background	N/A	
B	Bioaccumulation factor	NUREG-0133 (p. 16)	BF
b	Projected dose for a release	N/A	
B_{iv}	Transfer factor for nuclide i from soil to vegetation	R.G. 1.109 (p. 3)	B_{iv}
BR	Breathing rate	NUREG-0133 (p. 25)	BR
χ	Air concentration	R.G. 1.109 (p. 25)	χ
c	Any anticipated additional dose in the next month from other sources	N/A	
C	Concentration	NUREG-0133 (p. 15)	C
χ/Q	Relative concentration	R.G. 1.109 (p. 5)	χ/Q

APPENDIX A - NOTATION CONVENTIONS
(Page 2 of 7)

Symbol Key

WBN ODCM Symbol	Definition	Source Reference	Source Symbol
d	Number of days in the current quarter prior to the time of a release	N/A	
D	Dose	NUREG-0133 (p. 15)	D
D_{NF}	Near-field dilution	NUREG-0133 (p. 15)	F
D/Q	Relative deposition	R.G. 1.109 (p. 24)	δ
DFB	Dose Conversion Factor for total body submersion	R.G. 1.109 (p. 6)	DFB
DF_{β}	Dose Conversion Factor for beta air dose	R.G. 1.109 (p. 5)	DF_{β}
DFG	Dose conversion factor for standing on contaminated ground	NUREG-0133 (p. 26)	DFG
DF_{γ}	Dose conversion factor for gamma air dose	R.G. 1.109 (p. 5)	DF_{γ}
DF	Ingestion dose conversion factor	NUREG-0133 (p. 16, 33)	DF, DFL
DFA	Inhalation Dose Conversion Factor	NUREG-0133 (p. 25)	DFA
DFS	Dose conversion factor for skin submersion dose	R.G. 1.109 (p. 6)	DFS
DR	Dose rate	N/A	
dr	Relative deposition rate	R.G. 1.111 (p. 12)	dr
E	Efficiency	NUREG-1301 (p. 40)	E
ECL	Effluent Concentration Limit	N/A	
ER	Expected Monitor Response	N/A	
F	Dilution flow	NUREG-0133 Addendum A	F
f	Waste flow	NUREG-0133 Addendum A	f
F_f	Transfer factor from cow's feed to beef	R.G. 1.109 (p. 28)	F_f
f_g	Fraction of stored vegetables grown locally	R.G. 1.109 (p. 7)	f_g
FISH	Average amount of fish ingested	N/A	
f_{kl}	Joint relative frequency of occurrence of winds in windspeed class k and stability class l	R.G. 1.111 (p. 9)	n/N
f_L	Fraction of fresh leafy vegetables grown locally	R.G. 1.109 (p. 7)	F_l
F_m	Transfer factor from animal's feed to milk	R.G. 1.109 (p. 27)	F_m
fP	Fraction of population in an age group	R.G. 1.109 (p. 30)	f
f_p	Fraction of time animal spends on pasture	R.G. 1.109 (p. 28)	f_p

APPENDIX A - NOTATION CONVENTIONS
(Page 3 of 7)

Symbol Key

WBN ODCM Symbol	Definition	Source Reference	Source Symbol
f_s	Fraction of time animal spends on stored feed	R.G. 1.109 (p. 28)	f_s
H	Absolute humidity of the atmosphere	R.G. 1.109 (p. 27)	H
HRSVIS	Length of shoreline recreation visit	N/A	
HVST	Fish harvest for the Tennessee River	N/A	
K_c	Transfer coefficient from water to shoreline sediment	R.G. 1.109 (p. 14)	K_c
λ	Radioactive decay constant	N/A	
λ_E	Effective decay constant	R.G. 1.109 (p. 4)	λ_E
LLD	Lower Limit of detection	NUREG-1301 (p. 40)	LLD
λ_w	Weathering decay constant	R.G. 1.109 (p. 4)	λ_w
M	Mass density of sediment	R.G. 1.109 (p. 14)	M
n	Number of compass sectors	N/A	
P	Effective surface density of soil	R.G. 1.109 (p. 3)	P
p	Fraction of radionuclide remaining in plume	R.G. 1.111 (p. 12)	p
POP	Population	R.G. 1.109 (p. 30)	P
POPF	Population dose due to fish ingestion	R.G. 1.109 (p. 30)	D^P
POPR	Total recreation population dose	R.G. 1.109 (p. 30)	D^P
POPWTR	Population dose due to water ingestion	R.G. 1.109 (p. 30)	D^P
Q	Release rate	NUREG-0133 (p. 22)	Q
q	Total release in a period	NUREG-0133 (p. 29)	q
Q_f	Milk animal's consumption rate	R.G. 1.109 (p. 3)	Q_f
r	Fraction of activity retained on pasture grass.	R.G. 1.109 (p. 3)	r
R_p	Gaseous Dose Factor for Pathway P	NUREG-0133 (p. 26)	P
R_I	Inhalation dose factor	NUREG-0133 (p. 26)	P
R_G	Ground plane dose factor	NUREG-0133 (p. 26)	P
R_{CP}	Pasture grass-milk animal-milk ingestion	NUREG-0133 (p. 26)	P
R_{CS}	Stored feed-milk animal-milk ingestion	NUREG-0133 (p. 26)	P
R_{MP}	Pasture grass-beef ingestion	NUREG-0133 (p. 26)	P
R_{MS}	Stored feed-beef ingestion	NUREG-0133 (p. 26)	P
R_{VF}	Fresh leafy vegetable ingestion	NUREG-0133 (p. 26)	P

APPENDIX A - NOTATION CONVENTIONS
(Page 4 of 7)

Symbol Key

WBN ODCM Symbol	Definition	Source Reference	Source Symbol
R_{VS}	Stored vegetable ingestion	NUREG-0133 (p. 26)	P
R	Sum of the ratios	N/A	
RATIO	Ratio of average to maximum dose	N/A	
REQFRA	Fraction of yearly recreation which occurs in a quarter	N/A	
rf	Recreation factor	N/A	
RF	River flow	N/A	
s_b	Standard deviation	NUREG-1301 (p. 40)	s_b
SF	Safety factor	N/A	
SHVIS	Shoreline visits per year	N/A	
S_{max}	Setpoint corresponding to the ODCM Limit	N/A	
Σ_z	Vertical dispersion coefficient	R.G. 1.111 (p. 11)	Σ_z
σ_z	Vertical dispersion coefficient	R.G. 1.111 (p. 11)	σ_z
T	Duration of release	NUREG-0133 (p. 15)	Δt
Δt	Elapsed time between midpoint of sample collection and counting time	NUREG-1301 (p. 40)	Δt
TAF	Terrain adjustment factor	N/A	
t_b	Time period over which accumulation on the ground is evaluated	R.G. 1.109 (p. 14, 26)	t_b, t
t_{cb}	Time for receptor to consume a whole beef	N/A	
t_d	Distribution time for water, fish, milk, beef, or vegetables	R.G. 1.109 (p. 4)	t_p
t_{csf}	Time between harvest of stored feed and consumption by animal	R.G. 1.109 (p. 4)	t_h
t_e	Exposure time in garden for fresh leafy and/or stored vegetables	R.G. 1.109 (p. 4)	t_e
t_{ep}	Time pasture is exposed to deposition	R.G. 1.109 (p. 4)	t_e
t_{esf}	Time stored feed is exposed to deposition	R.G. 1.109 (p. 4)	t_e
TFDOS	Individual fish ingestion dose	R.G. 1.109 (p. 30)	D
t_{fm}	Transport time from milking to receptor	N/A	t_{fm}
t_{hc}	Average time between harvest of vegetables and their consumption and/or storage	R.G. 1.109 (p. 4)	t_h

APPENDIX A - NOTATION CONVENTIONS
(Page 5 of 7)

Symbol Key

WBN ODCM Symbol	Definition	Source Reference	Source Symbol
t_s	Transport time from slaughter to consumer	R.G. 1.109 (p. 28)	t_s
TSHDOS	Total shoreline dose rate	R.G. 1.109 (p. 30)	D
t_{sv}	Time period over which stored vegetables are consumed	N/A	
TWDOS	Total individual water dose	R.G. 1.109 (p. 30)	D
u	Wind speed	R.G. 1.111 (p. 9)	u
U_f	Fish consumption rate	NUREG-0133 (p. 16)	U_F
U_{FL}	Consumption rate of fresh leafy vegetables	R.G. 1.109 (p. 7)	U_L
U_m	Meat ingestion rate	R.G. 1.109 (p. 7)	U^F
U_p	Milk ingestion rate	R.G. 1.109 (p. 7)	U_p
U_R	Recreation usage factor	R.G. 1.109 (p. 14)	U
U_S	Consumption rate of stored vegetables by the receptor	R.G. 1.109 (p. 7)	U^V
U_w	Water consumption rate	NUREG-0133 (p. 16)	U_W
V	Sample size	NUREG-1301 (p. 40)	V
W	Dispersion factor	NUREG-0133 (p. 22)	W
SWF	Shoreline width factor	R.G. 1.109 (p. 14)	W
x	Downwind distance	R.G. 1.111 (p. 11)	x
Y	Radiochemical yield	NUREG-1301 (p. 40)	Y
Y_f	Agricultural yield for fresh leafy vegetables	R.G. 1.109 (p. 4)	Y_v
Y_p	Agricultural productivity by unit area of pasture grass	R.G. 1.109 (p. 4)	Y_v
Y_{sf}	Agricultural productivity by unit area of stored feed	R.G. 1.109 (p. 4)	Y_v
Y_{sv}	Agricultural yield for stored vegetables	R.G. 1.109 (p. 4)	Y_v

APPENDIX A - NOTATION CONVENTIONS
(Page 6 of 7)

List of Acronyms

ABGTS - Auxiliary Building Gas Treatment System
ALARA - As Low As Reasonably Achievable
CDCT - Cask Decontamination Collector Tank
CFR - Code of Federal Regulations
CTBD - Cooling Tower Blowdown
CVCS - Chemical Volume Control System
CVE - Condenser Vacuum Exhaust
EPA - Environmental Protection Agency
ERCW - Essential Raw Cooling Water
ESF - Engineered Safety Feature
FI - Flow Indicator
FSAR - Final Safety Analysis Report
GRTS - Gaseous Radwaste Treatment System
HCT - High Crud Tanks
HEPA - High Efficiency Particulate Air
LLD - Lower Limit of Detection
LM - Local Monitor
LPF - Loop Flow
LRTS - Liquid Radwaste Treatment System
NIST - National Institute of Standards and Technology
NRC - Nuclear Regulatory Commission
NRWT - Non-Reclaimable Waste Tank
ODCM - Offsite Dose Calculation Manual
PM - Perimeter Monitor
PWS - Public Water Supply
REMP - Radiological Environmental Monitoring Program
RE - Radiation Element
RM - Remote Monitor
SGBD - Steam Generator Blowdown
SQN - Sequoyah Nuclear Plant
SR - Surveillance Requirement
SSP - Site Standard Practice
TBS - Turbine Building Sump
TLD - Thermoluminescent Dosimeter
TRM - Tennessee River Mile
TS - Technical Specifications
WBN - Watts Bar Nuclear Plant
WGDT - Waste Gas Decay Tank

APPENDIX A - NOTATION CONVENTIONS
(Page 7 of 7)

List of Units

The following units are used consistently throughout the WBN ODCM. The table is included to provide the reader with the unit corresponding to each abbreviation used.

cc	cubic centimeters
cfs	cubic feet per second
Ci	Curie
cpm	counts per minute
d	day
g	gram
gpm	gallons per minute
h	hour
kg	kilogram
L	liter
lb	pound
m	meters
μ Ci	microcurie
mi	mile
min	minute
ml	milliliter
mrad	millirad
mrem	millirem
pCi	picocurie
s	second
y	year

Other Notes:

Equations in the text of the WBN ODCM are numbered by section, i.e., equations in Section 6.0 are numbered as 6.1, 6.2, etc. Only final equations are numbered; any equations which are reproduced from Regulatory Guides or NUREGs and used to derive a WBN specific equation are not numbered.

**APPENDIX B - Deviations in the WBN ODCM Controls/Surveillance
Requirements from Those Given in NUREG-1301
(Page 1 of 4)**

1. Controls 1.0.1 and 1.0.2 and Surveillance Requirements 2.0.1-2.0.4 have been replaced by the most recent WBN LCOs 3.0.1 and 3.0.2 and SRs 3.0.1-3.0.4. This has been done to ensure consistency between the WBN TS and the WBN ODCM.

2. Control 1/2.1.1 NUREG-1301 does not list the applicability for liquid monitoring instrumentation. Applicability for WBN liquid effluent instrumentation is defined in Table 1.1-1 to match the requirements provided in the ACTION statements associated with the table.
Table 2.1-1 - Channel calibration for the Diffuser Discharge Flow Indicator is changed to yearly due to requirements in the NPDES permit. This is more conservative than required by NUREG-1301.
Table 2.1-1 - The Channel Operational Test Frequency for Items 3.a (Radwaste Flow), 3.b (Steam Generator Blowdown Flow), and 3.c (Condensate Demineralizer Flow) are N/A. These items do not have an associated alarm, interlock, and/or trip setpoint, therefore a Channel Operational Test cannot be performed for these items.
Table 2.1-1 - Footnote 1 is deleted from Items 1.b (Steam Generator Blowdown Radiation) and 1.c (Condensate Demineralizer radiation). Item 1.b and 1.c generate an automatic isolation on level above the alarm/trip setpoint, not instrument malfunction.

Table 2.1-1 - The circuit failure test associated with the channel operational test (COT) has been deleted. By definition a COT verifies the channel can process an input signal and actuate output devices and that there are no circuit failures that impact the required functions. The notes in Tables 2.1-2 which supplement the COT definition require tests to verify operation of specific features that alert the operator of a malfunction. These include downscale failure (loss of counts), controls not in operate mode (switch mispositioned), and loss of sample flow. Circuit failure could be caused by any number of subcomponent failures. There is not a specific circuit that is monitoring for each of those subcomponent failures.

3. Control 1/2.1.2 - Table 1.1-2 limits operability for WGDT release instrumentation to periods of release.
Table 1.1-2 - Includes operability requirements for heat trace on iodine/particulate sample lines for Condenser Vacuum Exhaust and Shield Building Exhaust.
Tables 1.1-2 and 2.1-2 require that both Unit 1 and 2 Shield Building Exhaust monitors must meet operability requirements to operate either unit. This is because releases through the ABGTS may exit from either unit's Shield Building Vent.
Table 1.1-2 - Wording is added to clarify the Shield Building Vent monitor noble gas channel operability requirements. This monitor has the capability to read in units of $\mu\text{Ci}/\text{cc}$ or $\mu\text{Ci}/\text{s}$. The usual channel will read in $\mu\text{Ci}/\text{s}$, but this wording allows the monitor to be switched to read in $\mu\text{Ci}/\text{cc}$ if the flow channel becomes inoperable to eliminate the need for compensatory samples.
Table 1.1-2 - The Applicability for Items 2.a, c, and d (Condenser Vacuum Exhaust (CVE) radiation monitors and flow instruments) is MODES 1, 2, 3, and 4 and during MODES 5 and 6 with CVE System in operation. The radiation monitoring instrumentation does not have to be operable if the Exhaust system is not in operation.
Table 1.1-2 - Items 3.f and 4.e were added as part of the changes associated with operating with a TPBAR core.
Table 2.1-2 - Includes surveillance requirements for heat trace on iodine/particulate sample lines for Condenser Vacuum Exhaust and Shield Building Exhaust.
Table 2.1-2 - The channel operational test frequency for 3.b (Shield Building Exhaust Iodine and Particulate Sampler), and 4.b (Auxiliary Building Exhaust Iodine and Particulate Sampler) of Table 2.1-2 are N/A. These items have no associated alarm, interlock, and/or trip setpoint, therefore a Channel Operational Test cannot be performed.

**APPENDIX B - Deviations in the WBN ODCM Controls/Surveillance
Requirements from Those Given in NUREG-1301
(Page 2 of 4)**

Table 2.1-2 - The channel check requirements for all iodine and particulate samplers are N/A. The channel check requirement is intended to demonstrate that the sampler is operable. An indication of flow through the sampler verifies its operability. The daily channel check for the sampler flow(s) and the weekly sampler filter changeout required by the sampling and analysis program in Table 2.2-2 provide this indication of operability, therefore a channel check requirement in this Table is redundant.

Table 2.1-2 - The circuit failure test associated with the channel operational test (COT) has been deleted. By definition a COT verifies the channel can process an input signal and actuate output devices and that there are no circuit failures that impact the required functions. The notes in Tables 2.1-2 which supplement the COT definition require tests to verify operation of specific features that alert the operator of a malfunction. These include downscale failure (loss of counts), controls not in operate mode (switch mispositioned), and loss of sample flow. Circuit failure could be caused by any number of subcomponent failures. There is not a specific circuit that is monitoring for each of those subcomponent failures.

4. Control 1/2.1.3 is added to place the meteorological monitoring requirements in the ODCM.
5. Control 1/2.2.1.1 - Table 2.2-1, the requirements for sampling of continuous liquid release pathways (TBS and SGBD) are for daily grab samples rather than a continuous sampler. This is consistent with the requirements for SQN for the same points. The definition of a composite liquid effluent sample is somewhat different than that given in NUREG-1301 (WBN will be creating the composite in the lab from the grab samples, the NUREG is referring to a composite sample from a continuous sampler). The analyses for these daily grab samples are daily, rather than weekly. Each sample will be analyzed, rather than compositing the samples for the week.
Table 2.2-1 - Footnote 6 is added to require that the continuous liquid release points be sampled only if primary to secondary leakage is identified, and either the monitor must be set to two times background OR compensatory samples are being collected. This is consistent with requirements in the SQN effluent control program. The activity determination is clarified to state that principal gamma emitters will be used for the determination.
6. Control 1/2.2.2.1:
Table 2.2-2 is reformatted from the NUREG version to place more of the requirements in the table itself, and eliminate some of the footnotes. This allows easier implementation of the sampling requirements in plant procedures.
 - a. Table 2.2-2 requires sampling of containment purge and vent following shutdown, startup, or a thermal power change exceeding 15% of RATED THERMAL POWER within a 1 hour period. This is consistent with the NUREG, but WBN goes further to state that this does not need to be done if analysis shows that the DEI has not increased by a factor of 3 or more, AND if the lower containment noble gas monitor does not show an increase of a factor of 3 or more. This is consistent with the requirements in the SQN effluent control program.
 - b. Table 2.2-2, Footnote 8 details applicability and timing requirements for sampling of the containment for purges. This note is consistent with one in the SQN ODCM, except that MODE requirements and times are different.
 - c. Table 2.2-2, Footnote 8 details applicability and timing requirements for sampling for incore instrument room purges. This note is consistent with one in the SQN ODCM, except that MODE requirements and times are different.
 - c. Table 2.2-2, Footnote 10 details applicability requirements for sampling of the containment for venting. This note is consistent with one in the SQN ODCM, but details are different.

**APPENDIX B - Deviations in the WBN ODCM Controls/Surveillance
Requirements from Those Given in NUREG-1301
(Page 3 of 4)**

- d. Table 2.2-2, the Shield Building Exhaust is excluded from the monthly requirement for grab sampling to analyze for noble gas and tritium, since all releases through this point will have been quantified previously.
 - e. Table 2.2-2, Footnote 11 excludes the Condenser Vacuum Exhaust from the requirements for sampling until a primary to secondary leak is identified. The activity determination is clarified to state that principal gamma emitters will be used for the determination.
 - f. Table 2.2-2, the table limits the principal gamma emitters for grab samples to the noble gas nuclides to clarify that particulate releases are quantified from filter analyses.
 - g. Table 2.2-2 - Footnotes 3 and 7 allow compensatory grab samples to be used to determine if activity levels have increased during periods of radiation monitor inoperability.
 - h. Table 2.2-2 - Requirements for continuous tritium sampling were added for the Auxiliary Building Exhaust and Shield Building Exhaust to quantify releases during the irradiation and storage of TPBARs. Since tritium samples will be collected continuously footnotes 4 and 5, which required tritium grab samples, were removed. The use of continuous tritium samplers provides a more accurate account of the tritium released than grab samples.
 - i. Footnotes 8 and 10 clarifies that only the containment compartment to be released needs to be sampled. This will eliminate unnecessary sampling.
 - j. Table 2.2-2- Prior to release each Waste Gas Decay Tank will require tritium analysis as part as the changes associated with operating with a TPBAR core.
7. Control 1/2.3.1:
- a. Table 2.3-1 - the drinking water control sample location is defined in footnote 9 to be the upstream surface water sample.
 - b. Requirements for drinking water sample analysis differ from the NUREG. Due to the large downstream distance of the first public water supply (> 10 miles) and the volume of dilution water available, doses due to water ingestion will be very low under normal circumstances. This situation applies at both SQN and BFN and is reflected in their Environmental Monitoring Programs.
 - c. Text is added to Table 2.3-1 footnote 8 to state that the hydraulic gradient of the groundwater at the WBN site is such that the groundwater will move from the site toward the river, therefore groundwater sampling is not required.
 - d. Table 2.3-1 footnote 3 is added to clarify identification of control samples for iodine and particulate airborne monitoring.
 - e. Table 2.3-1, The invertebrate sampling requirements have been relocated to the waterborne section of the Table to more accurately reflect the purpose of these samples. There is negligible ingestion of invertebrates from the Tennessee River.
8. BASES 1/2.1.3 - Bases for the meteorological monitoring instrumentation Control are in the ODCM.
9. BASES 1/2.2.1.1 - An additional reference is given for further LLD discussion (ARH-SA-215, June 1975). Allocation of activity between the reactor units for dose calculation purposes is discussed in more detail.
10. BASES 1/2.2.1.2 - Text is added to explain that the dose for composited nuclides will be calculated using the values from the previous compositing period.
11. BASES 1/2.2.1.4 Allocation of activity between the reactor units for dose calculation purposes is discussed in more detail.

**APPENDIX B - Deviations in the WBN ODCM Controls/Surveillance
Requirements from Those Given in NUREG-1301
(Page 4 of 4)**

12. BASES 1/2.2.2.1 An additional reference is given for further LLD discussion (ARH-SA-215, June 1975). Allocation of activity between the reactor units for dose calculation purposes is discussed in more detail.
13. BASES 1/2.2.2.2 and 1/2.2.2.4 Allocation of activity between the reactor units for dose calculation purposes is discussed in more detail.
14. BASES 1/2.3.1 An additional reference is given for further LLD discussion (ARH-SA-215, June 1975).
15. The definitions of Member of the Public and Restricted area are not consistent with those given in NUREG-1301. This is due to the revision to 10 CFR 20 implemented by TVA on 1/1/94. The definitions are consistent with that regulation. Similar changes are made to the BASES sections to clarify the wording where these definitions are used. Figure 3.1 shows the locations of these boundaries and areas. A calculation is given in Section 7.7.6 for a member of the public inside the Site Boundary demonstrating that the location of the unrestricted area boundary on the opposite side of the Tennessee River meets the intent of the regulation.
16. The Source Check definition is changed to reflect changes made in the definition for SQN (revision 27). The new definition will allow the use of internal test circuits in lieu of a radioactive source (some monitors use an LED light source to provide the check signal to the photomultiplier tube).
17. The Operational Modes Table (Table 3.2) is consistent with the WBN TS.

APPENDIX C - WBN ODCM REVISION PROCESS (Page 1 of 7)

This Appendix establishes the minimum requirements for preparation, review, and approval of the Watts Bar Nuclear Plant Offsite Dose Calculation Manual. This Appendix also implements the requirements of ODCM Section 5.3 and WBN TS 5.7.2.3.

1.0 Reviewer Responsibilities

1.1 Affected Organization Review (AOR)

The identification of affected organizations is the responsibility of the Sponsor and applies to all revisions of the ODCM.

The affected organizations shall ensure that their reviewers have adequate understanding of the requirements and intent of the ODCM and access to pertinent background information.

The AO reviews the draft for impact on the organization and adequate interface - not technical content.

1.2 Independent Qualified Review (IQR)

An independent qualified review is the process of independent technical review by Qualified Reviewers of activities potentially affecting nuclear safety.

The IQR shall NOT be the person who prepared the ODCM revision.

An IQR is performed by an individual designated by responsible department level managers to perform an independent technical review of activities potentially affecting nuclear safety.

The IQR must be qualified to perform the 10 CFR 50.59 review.

1.3 Cross Disciplinary Review (CDR)

The need for a CDR is determined by the IQR.

CDR is a technical review by disciplines other than those responsible for the document preparation.

The CDR is responsible for only the technical aspects of the areas specified by the IQR and any portions of the document that support or justify those areas.

Persons performing CDR do not have to be IQR qualified.

1.4 Plant Operations Review Committee (PORC) Review

The PORC reviews and recommends final approval of the ODCM.

1.5 Approval Authority

The Plant Manager will approve all revisions to the ODCM as required by Technical Specifications.

Signature authority shall not be delegated to a lower level manager.

APPENDIX C - WBN ODCM REVISION PROCESS
(Page 2 of 7)

2.0 Processing ODCM Revisions

2.1 Requestor (If other than the Sponsor)

Identify the need for an ODCM improvement.

Prepare a justification for the ODCM revision.

Attach a marked-up copy of the existing ODCM.

Forward the requested ODCM revision to the sponsoring organization.

2.2 ODCM Sponsor

Evaluate requested changes and determine if necessary.

If the requested change is not necessary, return the request to the requestor with explanation why the change is not needed.

Incorporate all changes in a draft revision on BSL.

Rev 12

Identify the organizations to perform AOR and complete the top portion of Attachment A for each organization.

Distribute Attachment A to each Affected Organization and request completion of the review prior to expected PORC review date.

Obtain appropriate reviews of the ODCM revision in BSL.

Rev 12

2.3 Reviews

2.3.1 IQR

Review the ODCM using all questions on Attachment B as a guideline and forward comments to the Sponsor.

Identify discipline or organization to perform CDR, if needed.

APPENDIX C - WBN ODCM REVISION PROCESS
(Page 3 of 7)

2.3.2 Affected Organization Reviewer

Review the proposed changes on BSL and provide comments to the ODCM Sponsor.

Rev 12

Review the ODCM for impact on assigned organization, identify procedures/documents which require revision to implement the ODCM revision on the Attachment A, and return the Attachment A to the ODCM Sponsor.

2.4 Sponsor

Resolve comments and obtain reviewer's concurrence in BSL. Escalate any unresolved comments to appropriate management.

Rev 12

Ensure ODCM has been reviewed by sponsor and IQR in accordance with Attachment B.

Ensure all Affected Organizations have reviewed the ODCM change and have identified the affected procedures on Attachment A.

Ensure all IQR, and CDR review requirements have been met.

Assign an Effective Date typically 60 calendar days forward UNLESS there is reasonable justification for making it effective earlier, such as plant operating conditions, test schedules, commitment or corrective action deadlines, or implementation of upper-tier requirements, or lack of affected procedures identified on Attachment A.

2.5 PORC

Review changes and Attachment B. Document recommendation for approval in BSL.

Rev 12

2.6 Plant Manager

Approve the ODCM revision in BSL.

Rev 12

3.7 ODCM Sponsor

Record the ODCM approval date and implementation date on each completed Attachment A provided by the affected organizations.

Return the Attachment A to each affected organization.

3.8 Affected Organization

Revise procedures identified on the Attachment A and assign an effective date which matches that of the ODCM revision.

Complete the Attachment A and return to the ODCM Sponsor.

APPENDIX C - WBN ODCM REVISION PROCESS
(Page 4 of 7)

3.9 ODCM Sponsor

Ensure all Affected Organizations have completed and returned Attachment A prior to the effective date of the ODCM.

Forward the approved ODCM change to Management Services at least three working days before the implementation date.

The completed Attachments A and B are QA records, and are handled in accordance with the Document Control and Records Management Program.

Forward a completed copy of each revision to Licensing to be filed and forwarded to the NRC in the Annual Radiological Effluent Release Report.

3.10 Management Services

Issue the ODCM and implementing procedures on the effective date of the ODCM revision.

APPENDIX C - WBN ODCM REVISION PROCESS
(Page 6 of 7)

Attachment B

ODCM Review Checklist

All questions of this checklist are considered by the ODCM preparer and reviewed by the Independent Qualified Reviewer (IQR). Only the revised portion of the ODCM should be evaluated.

	Changes to Section(s) 1.0-5.0	YES	NO	N/A
1.	Does the revision meet the intent of the guidance provided in NUREG-1301 for radiological effluent and environmental monitoring controls/surveillance requirements?			
2.	Do definitions in Section 3.0 match those provided in the WBN TS, NUREG-1301, or other NRC guidance?			
3.	Do Administrative Controls in Section 5.0 match those provided in WBN TS, NUREG-1301, or other NRC guidance?			
4.	Does the ODCM fulfill the requirements of TVA, Federal or State Laws, WBN FSAR, and any other referenced requirements documents?			
5.	Does the numbering of the Control and its accompanying Surveillance Requirement correspond?			
6.	Are instrument/equipment numbers and units of measure an exact match with those on the equipment?			
7.	Does nomenclature accurately describe the equipment and correspond to label identifiers?			
8.	Are referenced documents applicable, valid, and listed in the reference section?			
9.	Does this change maintain the level of radioactive effluent control required by 10 CFR Part 20.1302, 40 CFR Part 190, 1- CFR Part 50.36a, and Appendix I to 10 CFR Part 50? Provide justification for answer:			

_____/_____
Preparer Date

_____/_____
IQR Date

APPENDIX C - WBN ODCM REVISION PROCESS
(Page 7 of 7)

Attachment B

ODCM Review Checklist (continued)

	Changes to Section(s) 6.0-11.0	YES	NO	N/A
10.	Are there methodologies given in Sections 6.0 through 9.0 which implement the applicable ODCM Controls?			
11.	Are references to ODCM Controls and Surveillance Requirements accurate and correct?			
12.	Are changes to setpoint calculation methodologies consistent with the guidance provided in NUREG-0133?			
13.	Are changes to liquid effluent concentration compliance methodologies consistent with the guidance provided in NUREG-0133 and 10 CFR Part 20?			
14.	Are changes to gaseous effluent dose rate calculation/compliance methodologies consistent with the guidance provided in NUREG-0133 and/or Regulatory Guide 1.109?			
15.	Are changes to dose or dose projection calculation/compliance methodologies consistent with the guidance provided in NUREG-0133 and/or Regulatory Guide 1.109?			
16.	Are instrument/equipment numbers and units of measure an exact match with those on the equipment?			
17.	Are referenced documents applicable, valid, and listed in the references?			
18.	Are ODCM Sections numbered consistently and consecutively?			
19.	Are references to other ODCM Sections correct?			
20.	Are references to ODCM Tables and Figures accurate and correct?			
21.	Are any new acronyms defined in Appendix A?			
22.	Are equations numbered consecutively?			
23.	Does dimensional analysis yield the correct units for equations?			
24.	Are terms used in equations defined after the equation (and in Appendix A) and the proper units given for that term?			
25.	Do units on equation terms which reference tables match the units used for that term in the Table?			
26.	Are references given for table and other values correct and accurate?			
27.	Do data values given match those in the reference?			
28.	Do text descriptions of release/discharge points in Sections 6.0 and 7.0 correspond with the Figures referenced in those sections?			
29.	The change does not adversely impact the accuracy or reliability of effluent, dose, or setpoint calculations? Provide justification for answer:			

_____/_____
Preparer / Date

_____/_____
IQR / Date

Enclosure 2

Watts Bar Nuclear Plant Process Control Program (PCP) Reporting Requirements

Section 2.4.D.2 and Section 2.4.E of the PCP address the reporting requirements applicable to the PCP. Section 2.4.D.2 requires that revisions to the PCP, which occurred during the reporting period of the Annual Radioactive Effluent Release Report (ARERR), be forwarded to NRC with the ARERR. Revision 1 of the PCP became effective on April 14, 2004, and a copy of this revision is attached. Section 2.4.E of the PCP requires that major changes to the radiological waste treatment systems be reported in conjunction with the ARERR. For this reporting period, no major changes to the radiological waste treatment systems were made.

TENNESSEE VALLEY AUTHORITY

WATTS BAR NUCLEAR PLANT

PCP

PROCESS CONTROL PROGRAM

REVISION 1

QUALITY RELATED

LEVEL OF USE: INFORMATION

PREPARED BY: Cheryl Whitaker

DATE: 04/05/04

SPONSORING ORGANIZATION: Radwaste

APPROVED BY: Ed Robinson

DATE: 04/14/04

EFFECTIVE DATE: 04/14/04

<p style="text-align: center;">WBN UNIT 0</p>	<p style="text-align: center;">PROCESS CONTROL PROGRAM</p>	<p style="text-align: center;">PCP Revision 1 Page 2 of 12</p>
---------------------------------------------------	------------------------------------------------------------	------------------------------------------------------------------------

REVISION LOG

<u>REVISION OR CHANGE NUMBER</u>	<u>EFFECTIVE DATE</u>	<u>AFFECTED PAGE NUMBER</u>	<u>DESCRIPTION OF REVISION OR CHANGE</u>
0	6-10-02	ALL	Initial issue replace PAI-13.01 (PER 01-017150-000). Intent Change.
1	04/14/04	ALL	Reworded section 2.3.B to clarify filters are dewatered and surveyed prior to placing in the HIC. Added a reference in to NRC Branch Technical Position on Concentration Averaging and Encapsulation. Insert level of use information. Changed sample frequency in section 2.1.C.to be consistent with references 5.1 and 5.4. Corrected minor typographical errors. These are intent changes.

TABLE OF CONTENTS

Section	Title	Page
	REVISION LOG.....	2
	TABLE OF CONTENTS.....	3
1.0	INTRODUCTION.....	4
2.0	DETAILS.....	4
2.1	Waste Characteristics.....	4
2.2	Processing of Wet Radioactive Waste.....	6
2.3	Waste Stream Processing Methods.....	8
2.4	Administrative Controls.....	8
3.0	RECORDS	9
4.0	DEFINITIONS.....	9
5.0	REFERENCES	11

WBN UNIT 0	PROCESS CONTROL PROGRAM	PCP Revision 1 Page 4 of 12
---------------	-------------------------	-----------------------------------

1.0 INTRODUCTION

1.1 PURPOSE

The purpose of the Watts Bar Nuclear Plant (WBN) Process Control Program (PCP) is to establish a program which provides reasonable assurance that all radioactive wastes processed at WBN for disposal at a land disposal facility are processed and packaged such that applicable Federal and State regulations and disposal site criteria are satisfied. The PCP contains a general description of the methods for controlling the processing and packaging of radioactive wastes, specific parameters for each method, and the administrative controls and quality assurance required to ensure compliance with applicable regulations and requirements. This PCP is not applicable to wastes transported to an off-site vendor for processing.

1.2 SCOPE

This PCP applies to the processing of wet solid radioactive wastes generated as a result of plant operation and maintenance. This PCP does not apply to the treatment of mixed radioactive and hazardous wastes.

2.0 DETAILS

2.1 WASTE CHARACTERISTICS

A. Waste Streams

1. There are six waste streams that have been identified at WBN. These are primary resins, secondary resins, mobile demineralizer resin, filter elements, oil, and dry active waste (DAW). This PCP is not normally applicable to DAW. Other waste streams may be identified based upon plant operating characteristics.
2. Primary resins are collected in the spent resin storage tank for blending, decay, and storage. Primary resin sources are Chemical and Volume Control System (CVCS) letdown demineralizers, boron recovery demineralizers, and the fuel pool demineralizers.
3. Secondary resins are generated from the condensate polisher demineralizers.
4. Mobile demineralizer resins are fed by several sources including floor drain wastes, equipment drain wastes, laundry and hot shower wastes, and chemical wastes.
5. Filter elements will be accumulated from one or more plant systems. These are CVCS, seal injection, boron recovery, and spent fuel pool clean-up.
6. Oil is contaminated with radioactivity from various areas within the plant, as a result of normal operation and maintenance.
7. The Condensate Demineralizer Waste Evaporator (CDWE) is not part of the Unit 1 license, but may be incorporated into the Unit 2 license application. If the CDWE is to be operated as part of the Unit 2 startup, the PCP shall be revised to incorporate the processing of the CDWE bottoms.
8. DAW is generated within the plant and is not appropriately attributed to the above mentioned waste streams. DAW normally includes paper, plastic, wood, metal, and other such material generated as a result of the operation and maintenance of the plant.

WBN UNIT 0	PROCESS CONTROL PROGRAM	PCP Revision 1 Page 5 of 12
-------------------	-------------------------	-----------------------------------

B. Waste Form

Wastes are processed as appropriate to ensure that the minimum physical characteristics required by 10 CFR 61 and disposal site criteria are met. All class B and C waste must be stabilized. This shall be accomplished by placement into a high integrity container (HIC), or by solidification using a process that produces a product which meets the stability requirements of 10 CFR 61, per section 2.2 of this PCP. The vendors topical report shall include documentation of testing which verifies that the HIC or solidified product meets these stability requirements. Additionally, WBN shall comply with Federal and/or State requirements imposed specifically on an approved HIC or solidification product which limit the type and/or radioactive concentration of the waste to be placed in the HIC or solidified product.

C. Waste Classification

Radioactive waste shall be classified as Class A, B, or C in accordance with the requirements of 10 CFR 61, using one or more of the classification methods given in the USNRC's "Low-Level Waste Licensing Branch Technical Position on Radioactive Waste Classification (May 1983)." and "NRC Branch Technical Position on Concentration Averaging and Encapsulation" dated January 17, 1995 which replaced section C.3 of the original 1983 Technical Position. Waste classification shall be in accordance with approved station procedures.

The following specific requirements shall be incorporated in the program for sampling and analysis for waste classification:

1. Analysis frequency shall be determined by the waste classification and the date of the last sample taken. Class A waste shall be sampled at least every two years while class B and C waste shall be sampled at least annually for the nuclides listed in Table 1 and Table 2 of 10 CFR 61.55 unless the stream is unavailable for sampling. For waste streams that are not processed annually, the annual analysis need not be performed until the waste is processed. Isotopic data from other PWR's may be utilized until annual analysis can be performed.
2. The results of these annual analysis shall be used to develop isotopic abundances and scaling factors for difficult to measure nuclides (i.e., beta emitters and transuranics) based on correlations between those nuclides and more easily measured gamma emitters.
3. Calculational methods for determining the total activity in each container shall be developed which utilizes the results from the annual analysis.
4. The classification program shall establish criteria and include provisions for an increased frequency for sampling and analysis required by paragraph 1 above, if the waste stream isotopic content may have changed by a factor of 10.

WBN UNIT 0	PROCESS CONTROL PROGRAM	PCP Revision 1 Page 6 of 12
---------------	-------------------------	-----------------------------------

2.2 PROCESSING OF WET RADIOACTIVE WASTE

A. Processing Methods

Wet radioactive waste processed at WBN shall be processed into a form acceptable for disposal at a licensed facility. Processing shall be performed utilizing vendor supplied equipment operated in accordance with the vendor's PCP and procedures. Any vendor selected to provide services or products used for compliance with 10 CFR 61 stability requirements shall have a topical report addressing 10 CFR 61 requirements under review or approved by the NRC. The topical reports and PCP's of other vendors may be referenced in this PCP even if all vendors are not actively providing service or products at WBN. However, if any vendor is selected whose documents are not referenced, this document shall be revised to reference them.

B. System Qualification Tests

1. Prior to the initial solidification of a given waste stream using a specified process, a test shall be conducted to demonstrate the ability of the process to produce an acceptable waste form over the range of critical parameters identified during the prequalification testing. Bounds for critical parameters and specific operating limits shall be specified in the vendor's PCP.
2. These tests shall be performed on laboratory scale or full scale specimens and shall ensure that the acceptance criteria specified in Section 2.2.E are achieved.
3. The dewatering process shall specify an endpoint for each dewatering evolution so as to assure that the acceptance criteria specified in Section 2.2.E are achieved.

C. Batch Processing

Each batch of waste offered for processing shall be sampled and analyzed, as appropriate, in accordance with site procedures, the vendor's PCP and the topical report that addresses the 10 CFR 61 stability requirements. This sampling shall:

1. Provide the necessary data to estimate curie content and to perform the waste classification analysis.
2. When solidification is involved, sampling shall provide data necessary to:
 - a. Ensure that waste stream parameters are within the bounds for critical parameters established in the vendor's PCP and topical report.
 - b. Verify the application of preestablished mix ratios.

<p style="text-align: center;">WBN UNIT 0</p>	<p style="text-align: center;">PROCESS CONTROL PROGRAM</p>	<p style="text-align: center;">PCP Revision 1 Page 7 of 12</p>
---------------------------------------------------	------------------------------------------------------------	------------------------------------------------------------------------

D. Testing/Inspections

1. Tests are performed on those wastes which are solidified to ensure the adequacy of the solidification agent and/or procedural technique. The vendor's PCP shall be used to verify the solidification of at least one representative test specimen from at least every tenth batch of each type waste being processed.
2. If any test specimen fails to verify solidification, the solidification of the batch under test shall be suspended until such time as additional test specimens can be obtained, alternative solidification parameters can be determined in accordance with the vendor's PCP, and a subsequent test verifies solidification. Solidification of the batch may then be resumed using the alternative solidification parameters determined by the vendor's PCP.
3. If the initial test specimen from a batch fails to verify solidification, the vendor's PCP shall provide for the collection and testing of representative test specimens from each consecutive batch of waste until at least 3 consecutive test specimens demonstrate solidification.

E. Acceptance Criteria

1. All classes of waste shall satisfy the following acceptance criteria:
 - a. Liquid wastes shall be solidified.
 - b. Solid waste containing liquids shall not contain freestanding liquid in excess of 1% of the internal volume of the container.
2. For wastes which require structural stability, the acceptance criteria are as follows:
 - a. The waste shall have structural stability.
 - b. Notwithstanding the provisions of Section 2.2.E.1, liquid wastes or wastes containing liquid shall be converted into a form in which the freestanding liquid shall not exceed 1% of the internal volume of the container when contained in a HIC, or 0.5% of the volume of the waste for waste processed to a stable form.

F. Corrective Actions

With processing not meeting the above acceptance criteria or otherwise not meeting disposal site, shipping and/or transportation requirements, suspend shipment of inadequately processed waste and correct the PCP, procedures, and/or waste processing equipment as necessary to prevent recurrence. The disposition of inadequately processed wastes will be handled on a case-by-case basis.

WBN UNIT 0	PROCESS CONTROL PROGRAM	PCP Revision 1 Page 8 of 12
---------------	-------------------------	-----------------------------------

2.3 WASTE STREAM PROCESSING METHODS

A. Spent Resins

1. Normally spent resins are processed for disposal by dewatering. The resin is transferred to the liner or HIC where it is processed utilizing vendor supplied services, per Section 2.2.
2. Alternatively, resins may be processed for disposal by solidification. The resins shall be sampled for isotopic content and PCP parameters as defined in the vendor's PCP. The resins are transferred to the vendor's processing skid where they are solidified per Section 2.2.

B. Spent Filter Elements

Spent filter elements are surveyed for dose rate prior to placement in a disposal container. The measured dose rate is used to calculate isotopic content using a dose-to-curie conversion and scaling factors per Section 2.1. Based on the isotopic content and waste classification, the appropriate process and container to be used for disposal are determined. Normally, filters are dewatered and placed in a liner or HIC; however, filters may be dried and handled as DAW if conditions allow, or may be encapsulated.

C. Miscellaneous Wastes

Sludges and other miscellaneous wastes will be collected and handled on a case-by-case basis, and processed per Section 2.2. Oil and, on a case-by-case basis, other acceptable liquid waste will normally be shipped off-site to a licensed incinerator for disposal.

2.4 ADMINISTRATIVE CONTROLS

A. Procedures

Activities associated with the implementation of the requirements of this program shall be conducted in accordance with approved procedures or vendor documents that have been reviewed and approved by WBN.

B. Quality Assurance/Quality Control

Quality assurance assessments are conducted by the Quality Assurance organization, and by the Corporate Radiological Control organization. Assessment findings are reviewed by WBN management. Quality control measures include site review of all radwaste vendor procedures before use and verification, by site personnel, of end points or acceptance criteria in vendor procedures. Quality control of solidification methods is performed through controlled testing of a minimum of one sample from each batch to be solidified. Proportions of solidification agents are established which meet the standards for waste form and free standing liquid criteria.

C. Training

WBN UNIT 0	PROCESS CONTROL PROGRAM	PCP Revision 1 Page 9 of 12
---------------	-------------------------	-----------------------------------

Personnel involved in processing radioactive waste for shipment are trained in site procedures, regulatory requirements, and disposal site criteria applicable to the individuals responsibilities. The retraining of personnel shall be at the frequency specified in site procedures.

D. Licensee Initiated Changes to the PCP

1. Licensee initiated changes to the PCP shall be documented and records of reviews performed shall be retained for the duration of the unit Operating License. This documentation shall contain:
 - a. Sufficiently detailed information to support the change(s) and appropriate analyses or evaluations justifying the change(s); and
 - b. A determination that the change(s) maintain the overall conformance of the solidified waste product to existing requirements of Federal, State, or other applicable regulations.
 - c. Shall be effective after review and acceptance by the Plant Operations Review Committee (PORC) and the approval of the Plant Manager.
2. Licensee initiated changes to the PCP shall be reported to the Commission in the Annual Radioactive Effluent Release Report for the period in which the revision was reviewed by the PORC, in accordance with the WBN Off-site Dose Calculation Manual (ODCM).

E. Major Changes To Liquid Gaseous Radwaste Treatment Systems

Licensee initiated major changes to the Radwaste Treatment Systems (liquid and gaseous) shall be reported to the Commission in the Annual Radioactive Effluent Release Report for the period in which the evaluation was reviewed by the PORC, in accordance with the WBN ODCM.

3.0 RECORDS

None

4.0 DEFINITIONS

Batch - An isolated quantity of waste to be processed having constant physical and chemical characteristics.

Dewatered - Wet solid wastes which have had excess water removed.

Free liquid - Uncombined liquid not bound by the solid matrix of the solid waste mass; capable of flowing.

Homogeneous - Of uniform composition; the waste is uniformly distributed throughout the container.

Liquid waste - Any aqueous or non-aqueous radioactive liquid which requires processing before disposal. This may include oils, chemicals, water, or other liquids unsuitable for inplant cleanup or treatment.

Mixed waste - Low level radioactive wastes containing chemical constituents which are hazardous under 40 CFR 261.

WBN UNIT 0	PROCESS CONTROL PROGRAM	PCP Revision 1 Page 10 of 12
---------------	-------------------------	------------------------------------

Solidification agent - Material which, when mixed in prescribed proportions with liquid or wet solid wastes, can form a free standing product with no free liquid.

Solidification - The conversion of wet wastes into a solid form that meets shipping and burial site criteria.

Stability - A property of the waste form such that it is able to maintain its structural integrity under the expected disposal conditions; stabilized waste should maintain its gross physical properties and identity over a 300 year period.

WBN UNIT 0	PROCESS CONTROL PROGRAM	PCP Revision 1 Page 11 of 12
---------------	-------------------------	------------------------------------

5.0 REFERENCES

- 5.1 Code of Federal Regulations (CFR) Title 10, Parts 20, 61, 71; 10 CFR 20, 10 CFR 61, 10 CFR 71.
- 5.2 Code of Federal Regulations (CFR) Title 49.
- 5.3 Watts Bar Nuclear Plant Off-site Dose Calculation Manual
- 5.4 USNRC Low Level Waste Licensing Branch Technical Position on Radioactive Waste Classification, May 1983
- 5.5 USNRC Low Level Waste Licensing Branch Technical Position on Radioactive Waste Form, January 1991
- 5.6 NRC Branch Technical Position on Concentration Averaging and Encapsulation, January 1995
- 5.7 Topical Report CNSI DW-11118-01-P-A for Chem-Nuclear Systems, Inc., Dewatering Control Process Containers
- 5.8 CNSI, FO-OP-023, Bead Resin/Activated Carbon Dewatering Procedure for CNSI 14-215 or Smaller Liners
- 5.9 CNSI, FO-OP-19, Polyethylene High Integrity Container Overpack Handling Procedure
- 5.10 CNSI, FO-AD-002, Operating Guidelines for Use of Polyethylene High Integrity Containers

WBN UNIT 0	PROCESS CONTROL PROGRAM	PCP Revision 1 Page 12 of 12
---------------	-------------------------	------------------------------------

Source Notes

None.