

**UNITED STATES NUCLEAR REGULATORY COMMISSION
BOILING WATER REACTOR GENERIC FUNDAMENTALS EXAMINATION
JUNE 2004--FORM A**

Please Print

Name: _____

Facility: _____

Docket No.: _____

Start Time: _____ Stop Time: _____

INSTRUCTIONS TO APPLICANT

Answer all the test items using the answer sheet provided, ensuring a single answer is marked for each test item. Each test item has equal point value. A score of at least 80% is required to pass this portion of the NRC operator licensing written examination. All examination papers will be collected 3.0 hours after the examination starts. This examination applies to a typical boiling water reactor (BWR) nuclear power plant.

SECTION	QUESTIONS	% OF TOTAL	SCORE
COMPONENTS	1 - 22		
REACTOR THEORY	23 - 36		
THERMODYNAMICS	37 - 50		
TOTALS	50		

All work performed on this examination is my own. I have neither given nor received aid.

Applicant's Signature

**RULES AND GUIDELINES FOR THE NRC
GENERIC FUNDAMENTALS EXAMINATION**

During the administration of this examination the following rules apply:

NOTE: The generic term "control rod" refers to the length of neutron absorber material that can be positioned by the operator to change core reactivity.

1. Print your name in the blank provided on the cover sheet of the examination.
2. Fill in the name of your facility.
3. Fill in your individual docket number.
4. Fill in your start and stop times at the appropriate time.
5. Two aids are provided for your use during the examination:
 - (1) An equations and conversions sheet contained within the examination copy, and
 - (2) Steam tables provided by your proctor.
6. Place your answers on the answer sheet provided. Credit will only be given for answers properly marked on this sheet. Follow the instructions for filling out the answer sheet.
7. Scrap paper will be provided for calculations.
8. Cheating on the examination will result in the automatic forfeiture of this examination. Cheating could also result in severe penalties.
9. Restroom trips are limited. Only **ONE** examinee may leave the room at a time. In order to avoid the appearance or possibility of cheating, avoid all contact with anyone outside of the examination room.
10. After you have completed the examination, sign the statement on the cover sheet indicating that the work is your own and you have neither given nor received any assistance in completing the examination.
11. Turn in your examination materials, answer sheet on top, followed by the examination booklet, then examination aids - steam table booklets, handouts, and scrap paper used during the examination.
12. After turning in your examination materials, leave the examination area, as defined by the proctor. If after leaving you are found in the examination area while the examination is in progress, your examination may be forfeited.

GENERIC FUNDAMENTALS EXAMINATION
EQUATIONS AND CONVERSIONS HANDOUT SHEET

EQUATIONS

$$\dot{Q} = \dot{m}c_p\Delta T$$

$$\dot{Q} = \dot{m}\Delta h$$

$$\dot{Q} = UA\Delta T$$

$$\dot{Q} \propto \dot{m}_{\text{Nat Circ}}^3$$

$$\Delta T \propto \dot{m}_{\text{Nat Circ}}^2$$

$$K_{\text{eff}} = 1/(1 - \rho)$$

$$\rho = (K_{\text{eff}} - 1)/K_{\text{eff}}$$

$$\text{SUR} = 26.06/\tau$$

$$\tau = \frac{\bar{\beta} - \rho}{\lambda_{\text{eff}} \rho}$$

$$\rho = \frac{\ell^*}{\tau} + \frac{\bar{\beta}}{1 + \lambda_{\text{eff}}\tau}$$

$$\ell^* = 1 \times 10^{-4} \text{ sec}$$

$$\lambda_{\text{eff}} = 0.1 \text{ sec}^{-1} \text{ (for small positive } \rho)$$

$$\text{DRW} \propto \phi_{\text{tip}}^2 / \phi_{\text{avg}}^2$$

$$P = P_o 10^{\text{SUR}(t)}$$

$$P = P_o e^{(t/\tau)}$$

$$A = A_o e^{-\lambda t}$$

$$\text{CR}_{\text{S/D}} = S/(1 - K_{\text{eff}})$$

$$\text{CR}_1(1 - K_{\text{eff}1}) = \text{CR}_2(1 - K_{\text{eff}2})$$

$$1/M = \text{CR}_1/\text{CR}_x$$

$$A = \pi r^2$$

$$F = PA$$

$$\dot{m} = \rho A \bar{v}$$

$$\dot{W}_{\text{pump}} = \dot{m}\Delta P v$$

$$E = IR$$

$$\text{Eff.} = \text{Net Work Out/Energy In}$$

$$v(P_2 - P_1) + \frac{(\bar{v}_2^2 - \bar{v}_1^2)}{2g_c} + \frac{g(z_2 - z_1)}{g_c} = 0$$

$$g_c = 32.2 \text{ lbm-ft/lbf-sec}^2$$

CONVERSIONS

$$1 \text{ Mw} = 3.41 \times 10^6 \text{ Btu/hr}$$

$$1 \text{ hp} = 2.54 \times 10^3 \text{ Btu/hr}$$

$$1 \text{ Btu} = 778 \text{ ft-lbf}$$

$$^\circ\text{C} = (5/9)(^\circ\text{F} - 32)$$

$$^\circ\text{F} = (9/5)(^\circ\text{C}) + 32$$

$$1 \text{ Curie} = 3.7 \times 10^{10} \text{ dps}$$

$$1 \text{ kg} = 2.21 \text{ lbm}$$

$$1 \text{ gal}_{\text{water}} = 8.35 \text{ lbm}$$

$$1 \text{ ft}^3_{\text{water}} = 7.48 \text{ gal}$$

**USNRC GENERIC FUNDAMENTALS EXAMINATION
JUNE 2004 BWR--FORM A**

QUESTION: 1

Refer to the drawing of a water supply pump with two suction sources (see figure below). All motor-operated valves (MOVs) are currently closed.

Which one of the following MOV interlocks will permit the pump to take a suction on either the building sump or the water storage tank, while preventing the two sources from being cross-connected?

- A. Neither MOV-1 nor MOV-2 can be opened unless MOV-3 is fully closed.
- B. None of the MOVs can be opened unless at least one MOV remains fully closed.
- C. None of the MOVs can be opened unless at least two MOVs remain fully closed.
- D. Neither MOV-1 nor MOV-2 can be opened unless the other source MOV is fully closed.

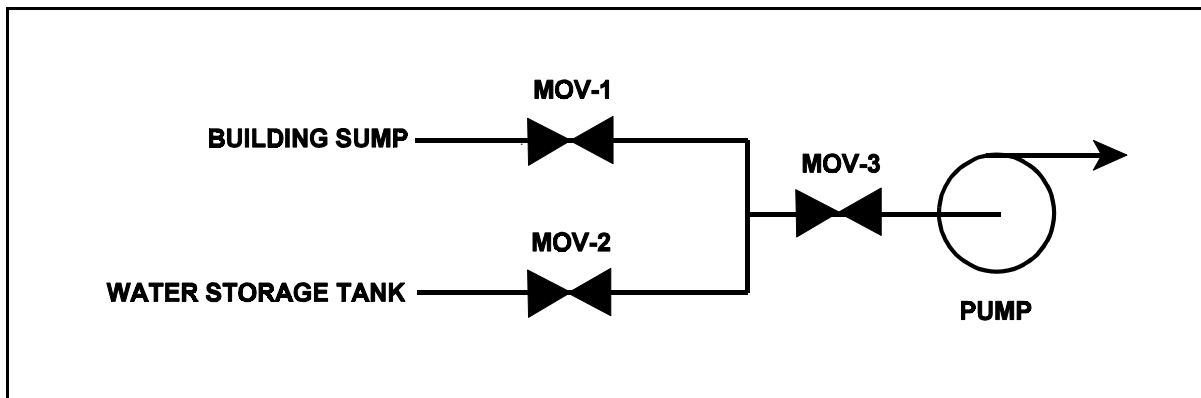

**USNRC GENERIC FUNDAMENTALS EXAMINATION
JUNE 2004 BWR--FORM A**

QUESTION: 2

Why must an operator pay particular attention when an auto/manual valve controller is placed in the manual mode?

- A. Manual valve control is not as stable as automatic valve control.
- B. Valve position will no longer change in response to changes in system parameters.
- C. The position of the valve can only be determined locally during manual control.
- D. The valve can only be operated locally during manual control.

QUESTION: 3

Various types of valves are being considered for use in an application that requires local manual closure capability in the event of an inoperable motor actuator.

Which one of the following types of similarly sized valves requires the most manual valve stem rotation to move the valve from fully open to fully closed? (Assume that each valve has a non-rising stem.)

- A. Ball
- B. Gate
- C. Plug
- D. Butterfly

**USNRC GENERIC FUNDAMENTALS EXAMINATION
JUNE 2004 BWR--FORM A**

QUESTION: 4

A venturi is being used to measure flow rate in a cooling water system. As the cooling water flows from the inlet to the throat of the venturi, water pressure will _____ and volumetric flow rate will _____. (Assume water is incompressible.)

- A. increase; remain the same
- B. increase; increase
- C. decrease; remain the same
- D. decrease; increase

QUESTION: 5

A differential pressure detector is being used with an orifice plate to measure water flow rate through a pipe. When the flow instrument was last calibrated, the following parameters were observed:

Upstream Pressure: 125 psig	Actual Flow Rate: 100 gpm
Downstream Pressure: 116 psig	Indicated Flow Rate: 100 gpm

Since the calibration, debris has collected in the orifice such that the actual flow rate through the orifice has decreased to 80 gpm while the upstream and downstream pressures have changed to 135 psig and 110 psig, respectively.

What is the approximate flow rate that is currently indicated by the flow instrument?

- A. 125 gpm
- B. 133 gpm
- C. 156 gpm
- D. 167 gpm

**USNRC GENERIC FUNDAMENTALS EXAMINATION
JUNE 2004 BWR--FORM A**

QUESTION: 6

Refer to the drawing of an open water storage tank with a differential pressure (D/P) level detector (see figure below).

The level instrument has just been calibrated to indicate actual tank water level. Assume that tank water temperature and level remain constant. If the reference leg temperature increases by 20°F, indicated tank water level will...

- A. be unpredictable.
- B. equal the actual level.
- C. read less than the actual level.
- D. read greater than the actual level.

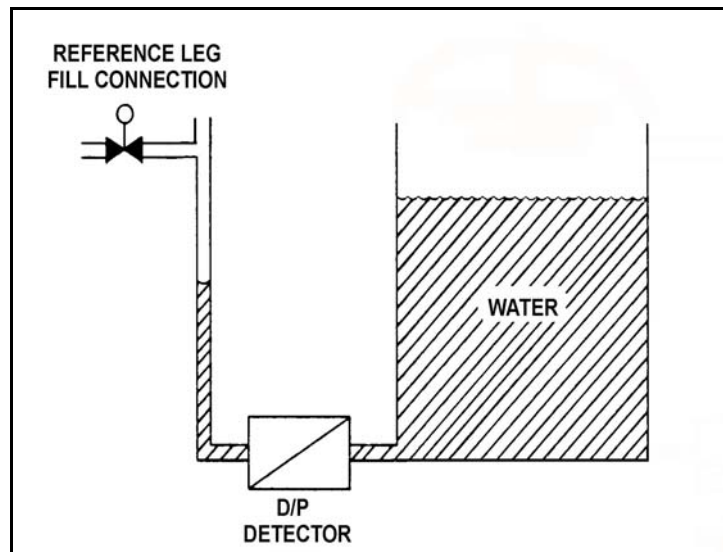

**USNRC GENERIC FUNDAMENTALS EXAMINATION
JUNE 2004 BWR--FORM A**

QUESTION: 7

What is the effect on a proportional neutron detector if it is operated at a voltage near the high end of the proportional (true proportional) region on the gas-filled detector characteristic curve?

- A. Neutron-induced pulses will become so large that gamma pulse discrimination is no longer needed, yielding a more accurate neutron count rate.
- B. The positive space charge effect will increase and prevent collection of both gamma- and neutron-induced pulses, yielding a less accurate neutron count rate.
- C. A high rate of incident gamma radiation will result in the combination of multiple small gamma-induced pulses into larger pulses. The larger combined pulses will be counted as neutron-induced pulses, yielding a less accurate neutron count rate.
- D. Detection of any single ionizing event will result in ionizing nearly the entire detector gas volume. The resulting large pulses will prevent the detector from differentiating between radiation types, yielding a less accurate neutron count rate.

**USNRC GENERIC FUNDAMENTALS EXAMINATION
JUNE 2004 BWR--FORM A**

QUESTION: 8

Refer to the drawing of a water storage tank with an automatic level control system (see figure below).

Given:

- The drain valve fails open on loss of controller output signal.
- The level sensor output signal changes directly with tank water level.

For proper automatic control of tank water level, the controller must be _____; and the control loop must be _____.

- A. direct-acting; open
- B. direct-acting; closed
- C. reverse-acting; open
- D. reverse-acting; closed

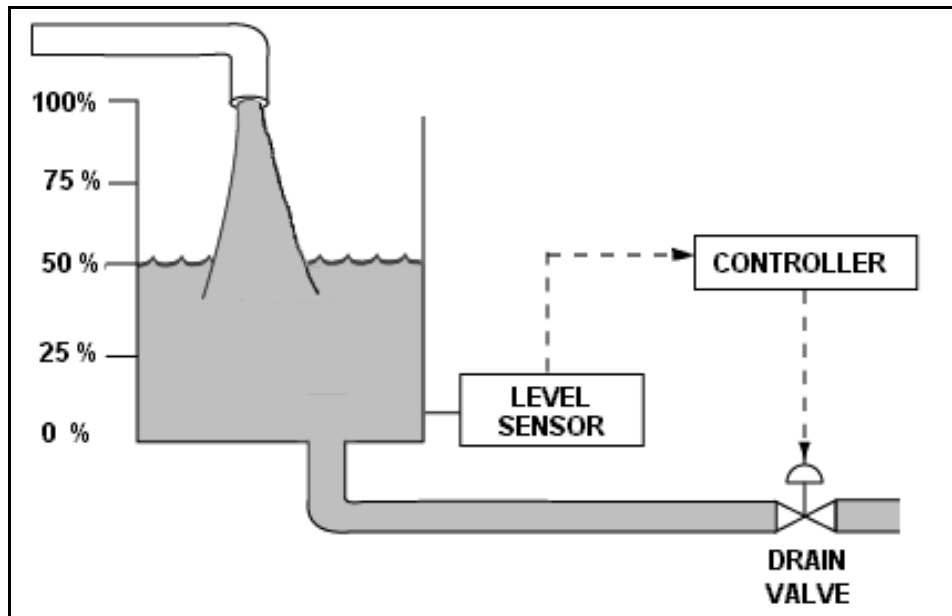

**USNRC GENERIC FUNDAMENTALS EXAMINATION
JUNE 2004 BWR--FORM A**

QUESTION: 9

A diesel generator (DG) is supplying an isolated electrical bus with the DG governor operating in the speed droop mode. Assuming the DG does not trip, if a large electrical bus load trips, bus frequency will initially...

- A. increase, then decrease and stabilize below the initial value.
- B. increase, then decrease and stabilize above the initial value.
- C. decrease, then increase and stabilize below the initial value.
- D. decrease, then increase and stabilize above the initial value.

QUESTION: 10

Which one of the following is an effective method for ensuring that a centrifugal pump remains primed and does not become gas bound during operation and after shutdown?

- A. Install an orifice plate in the discharge piping of the pump.
- B. Install a pump recirculation line from the pump discharge piping to the pump supply piping.
- C. Install the pump below the level of the suction supply.
- D. Install a check valve in the discharge piping of the pump.

**USNRC GENERIC FUNDAMENTALS EXAMINATION
JUNE 2004 BWR--FORM A**

QUESTION: 11

Refer to the drawing below of a centrifugal pump taking suction from the bottom of an open storage tank containing water at 66°F. Pump and water level elevations are indicated in the figure. Assume standard atmospheric pressure.

Assuming that pump suction fluid velocity head loss is negligible, what is the approximate value of net positive suction head available to the pump.

- A. 6 feet
- B. 13 feet
- C. 20 feet
- D. 25 feet

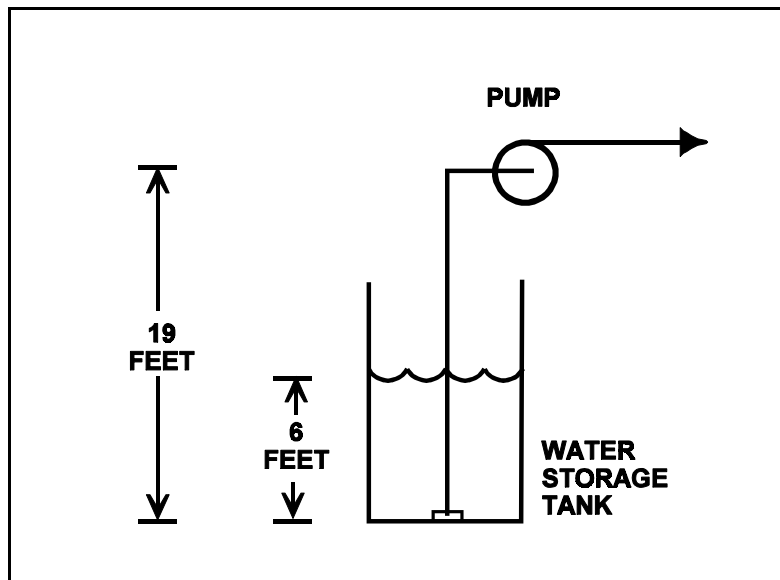

**USNRC GENERIC FUNDAMENTALS EXAMINATION
JUNE 2004 BWR--FORM A**

QUESTION: 12

A centrifugal fire water pump takes a suction on an open storage tank and discharges through a fire hose. Which one of the following will cause the pump to operate at shutoff head?

- A. A firefighter inadvertently severs the fire hose.
- B. The fire hose becomes partially crimped in a fire door.
- C. Fire water storage tank level drops below the pump suction tap.
- D. A firefighter adjusts the fire hose nozzle spray pattern from “deluge” to “off”.

QUESTION: 13

Which one of the following describes the typical purpose of minimum flow piping for a centrifugal pump?

- A. Prevent pump runout during high flow conditions.
- B. Prevent vortexing at the pump suction during high flow conditions.
- C. Ensure adequate net positive suction head during low flow conditions.
- D. Ensure adequate pump cooling during low flow conditions.

**USNRC GENERIC FUNDAMENTALS EXAMINATION
JUNE 2004 BWR--FORM A**

QUESTION: 14

Two identical 1000 MW ac electrical generators are operating in parallel supplying all the loads on a common electrical bus. The generator output breakers also provide identical protection for the generators. Generator A and B output indications are as follows:

<u>Generator A</u>	<u>Generator B</u>
28,000 KV	28,000 KV
60 Hertz	60 Hertz
150 MW	100 MW
25 MVAR (out)	50 MVAR (out)

A malfunction causes the voltage regulator set point for generator B to slowly and continuously decrease. If no operator action is taken, the current indication for generator B will...

- A. initially decrease, and then increase until the output breaker for generator A trips on overcurrent.
- B. initially decrease, and then increase until the output breaker for generator B trips on overcurrent.
- C. decrease continuously until the output breaker for generator A trips on overcurrent.
- D. decrease continuously until the output breaker for generator B trips on reverse power.

**USNRC GENERIC FUNDAMENTALS EXAMINATION
JUNE 2004 BWR--FORM A**

QUESTION: 15

Refer to the drawing of an electrical system power curve (see figure below).

If the system is operating at point A, which one of the following is the power factor for this system?

- A. 0.80
- B. 0.88
- C. 0.93
- D. 0.97

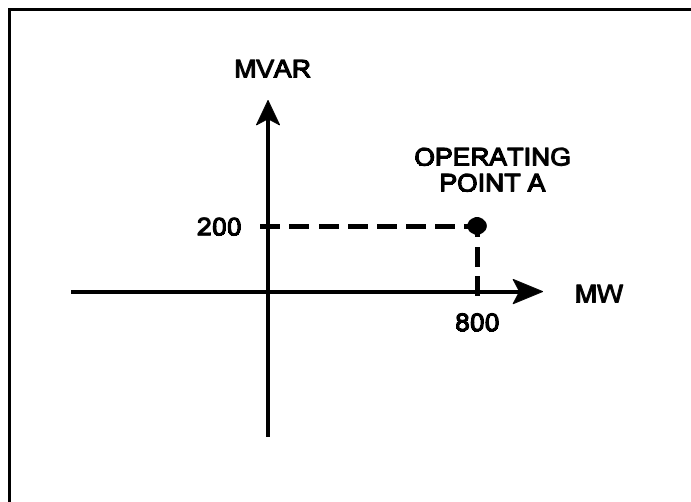

**USNRC GENERIC FUNDAMENTALS EXAMINATION
JUNE 2004 BWR--FORM A**

QUESTION: 16

Which one of the following describes the proper sequence for placing a steam (shell) and water (tube) heat exchanger into service?

- A. Water side is valved in before the steam side to ensure adequate venting.
- B. Water side is valved in before the steam side to minimize thermal shock.
- C. Steam side is valved in before the water side to minimize scale buildup on the heat exchanger tubes.
- D. Steam side is valved in before the water side to ensure that the cooldown rate does not exceed 100°F/hr.

QUESTION: 17

The rate of heat transfer between two liquids in a heat exchanger will be decreased if the: (Assume single-phase conditions and a constant specific heat for both liquids.)

- A. inlet temperature of the hotter liquid is increased by 20°F.
- B. inlet temperature of the colder liquid is decreased by 20°F.
- C. flow rates of both liquids are decreased by 10%.
- D. flow rates of both liquids are increased by 10%.

**USNRC GENERIC FUNDAMENTALS EXAMINATION
JUNE 2004 BWR--FORM A**

QUESTION: 18

Refer to the drawing of an operating lube oil heat exchanger (see figure below).

Given the following initial parameters:

Cooling water inlet temperature (T_{cw-in}) = 75°F
Cooling water outlet temperature (T_{cw-out}) = 95°F
Oil inlet temperature (T_{oil-in}) = 150°F
Oil outlet temperature ($T_{oil-out}$) = 120°F

Air introduction to the heat exchanger results in some of the heat exchanger tubes becoming uncovered. As a result, T_{cw-out} decreases to 91°F. Assume the inlet temperatures, mass flow rates, and specific heats of both fluids remain the same.

Which one of the following will be the new approximate temperature of the oil exiting the heat exchanger ($T_{oil-out}$)?

- A. 126°F
- B. 130°F
- C. 134°F
- D. 138°F

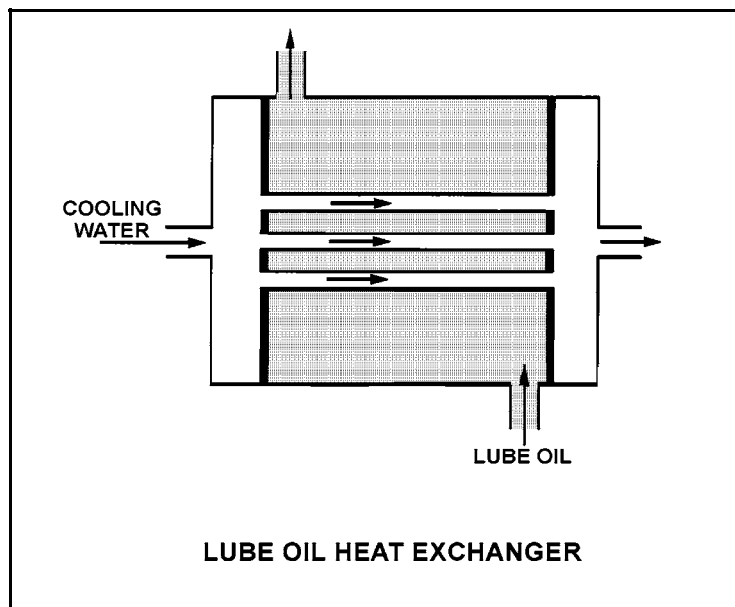

**USNRC GENERIC FUNDAMENTALS EXAMINATION
JUNE 2004 BWR--FORM A**

QUESTION: 19

Which one of the following conditions will lead to channeling in a demineralizer?

- A. Suspended solids and insoluble particles forming a mat on the surface of the resin bed.
- B. A sudden 10°F decrease in the temperature of the influent to the demineralizer.
- C. Exhaustion of the resin bed due to high conductivity of the demineralizer influent.
- D. Operation of the demineralizer with influent flow rate at 10% below design flow rate.

QUESTION: 20

Which one of the following describes the process of regenerating a mixed-resin deep bed demineralizer? (Assume the demineralizer has already been backwashed.)

- A. Alternating the flow of acidic and caustic solutions through the demineralizer to remove suspended solids and colloidal matter.
- B. Alternating the flow of acidic and caustic solutions through the demineralizer to remove ionic impurities.
- C. Reversing flow of pure water through the demineralizer to remove suspended solids and colloidal matter.
- D. Reversing flow of pure water through the demineralizer to remove ionic impurities.

**USNRC GENERIC FUNDAMENTALS EXAMINATION
JUNE 2004 BWR--FORM A**

QUESTION: 21

Given the following indications for an open 4160 Vac breaker:

The local OPEN/CLOSED mechanical flag indicates open
A breaker overcurrent trip flag is actuated on one phase
The line-side voltmeter indicates 4160 Vac
The load-side voltmeter indicates 0 volts

Assuming no operator actions were taken since the breaker opened, which one of the following could have caused the breaker to open?

- A. A ground fault caused an automatic breaker trip.
- B. An operator tripped the breaker normally at the breaker.
- C. A loss of control power caused an automatic breaker trip.
- D. An operator tripped the breaker normally from a remote location.

QUESTION: 22

A typical 120 Vac manual circuit breaker has tripped due to overload. To close this circuit breaker the handle must be moved from the...

- A. OFF position directly to the ON position; trip latch reset is not required.
- B. midposition directly to the ON position; trip latch reset is not required.
- C. OFF position to the midposition to reset the trip latch, and then to the ON position.
- D. midposition to the OFF position to reset the trip latch, and then to the ON position.

**USNRC GENERIC FUNDAMENTALS EXAMINATION
JUNE 2004 BWR--FORM A**

QUESTION: 23

During moderation of a fission neutron, the neutron is most susceptible to resonance absorption when it is a/an _____ neutron.

- A. slow
- B. fast
- C. epithermal
- D. thermal

QUESTION: 24

With $K_{\text{eff}} = 0.985$, how much positive reactivity is required to make the reactor exactly critical?

- A. 1.487% $\Delta K/K$
- B. 1.500% $\Delta K/K$
- C. 1.523% $\Delta K/K$
- D. 1.545% $\Delta K/K$

**USNRC GENERIC FUNDAMENTALS EXAMINATION
JUNE 2004 BWR--FORM A**

QUESTION: 25

Two nuclear reactors are identical in every way except that reactor A is near the end of core life and reactor B is near the beginning of core life. Both reactors are operating at 100% power when a reactor scram occurs at the same time on each reactor. The reactor systems for each reactor respond identically to the scram and no operator action is taken.

Ten minutes after the scram, the higher fission rate will exist in reactor _____ because it has a _____ delayed neutron fraction.

- A. A; larger
- B. B; larger
- C. A; smaller
- D. B; smaller

QUESTION: 26

Which one of the following pairs of isotopes is responsible for the negative reactivity associated with a fuel temperature increase near the end of core life?

- A. U-235 and Pu-239
- B. U-235 and Pu-240
- C. U-238 and Pu-239
- D. U-238 and Pu-240

**USNRC GENERIC FUNDAMENTALS EXAMINATION
JUNE 2004 BWR--FORM A**

QUESTION: 27

A nuclear reactor has been shut down for one week from long-term power operation and shutdown cooling is in service. Upon a loss of cooling water to the shutdown cooling heat exchangers, which one of the following coefficients of reactivity will act first to change core reactivity? (Assume continued forced circulation through the core.)

- A. Moderator temperature coefficient
- B. Fuel temperature coefficient
- C. Void coefficient
- D. Pressure coefficient

QUESTION: 28

Rod position indications indicate that a control rod is at position 16. When the control rod is moved to position 22, it is being...

- A. inserted 18 inches.
- B. withdrawn 18 inches.
- C. inserted 36 inches.
- D. withdrawn 36 inches.

**USNRC GENERIC FUNDAMENTALS EXAMINATION
JUNE 2004 BWR--FORM A**

QUESTION: 29

Criticality has been achieved during a xenon-free reactor startup. The core neutron flux level is low in the intermediate range and a stable positive 60-second reactor period has been established. The operator begins inserting control rods in an effort to stabilize the core neutron flux level near its current value. The operator stops inserting control rods exactly when the reactor period indicates infinity.

Immediately after the operator stops inserting the control rods, the reactor period will become _____; then the core neutron flux level will _____.

- A. positive; increase exponentially
- B. positive; increase linearly
- C. negative; decrease exponentially
- D. negative; decrease linearly

QUESTION: 30

Fission product poisons can be differentiated from other fission products in that fission product poisons...

- A. have a longer half-life.
- B. are stronger absorbers of thermal neutrons.
- C. are produced in a larger percentage of fissions.
- D. have a higher fission cross section for thermal neutrons.

**USNRC GENERIC FUNDAMENTALS EXAMINATION
JUNE 2004 BWR--FORM A**

QUESTION: 31

A reactor scram recently occurred from steady state 100% power and a reactor startup is currently in progress. Which one of the following sets of initial startup conditions will require the most control rod withdrawal to achieve criticality? (BOC = beginning of fuel cycle; EOC = end of fuel cycle.)

	<u>CORE AGE</u>	<u>TIME SINCE REACTOR SCRAM</u>
A.	BOC	12 hours
B.	BOC	40 hours
C.	EOC	12 hours
D.	EOC	40 hours

QUESTION: 32

Which one of the following is not a function performed by burnable poisons in an operating reactor?

- A. Provide neutron flux shaping.
- B. Provide more uniform power density.
- C. Counteract the effects of control rod burnout.
- D. Allow higher fuel enrichment of initial core load.

**USNRC GENERIC FUNDAMENTALS EXAMINATION
JUNE 2004 BWR--FORM A**

QUESTION: 33

A nuclear reactor is undergoing a startup with reactor pressure and temperature initially stable at 731.4 psia and 508°F. Main steam isolation valves are closed and reactor criticality has been achieved. The reactor currently has a stable positive 100-second reactor period with reactor power well below the point of adding heat (POAH).

Which one of the following will occur first when reactor power reaches the POAH?

- A. Reactor period will shorten.
- B. Reactor pressure will increase.
- C. Reactor coolant temperature will decrease.
- D. Intermediate range power level will decrease.

QUESTION: 34

A nuclear reactor is initially critical in the source range. Then a constant rate addition of positive reactivity commences and lasts for 120 seconds. Assume reactor power remains below the point of adding heat for the entire 120 second time interval.

During the 120 second time interval, reactor period will initially shorten and then _____; and reactor power will initially increase and then _____.

- A. continue to shorten at a decreasing rate; continue to increase at an increasing rate
- B. continue to shorten at a decreasing rate; continue to increase at a decreasing rate
- C. continue to shorten at a increasing rate; continue to increase at an increasing rate
- D. continue to shorten at an increasing rate; continue to increase at a decreasing rate

**USNRC GENERIC FUNDAMENTALS EXAMINATION
JUNE 2004 BWR--FORM A**

QUESTION: 35

Neglecting the effects of changes in core Xe-135, which one of the following power changes requires the smallest amount of positive reactivity addition?

- A. 3% power to 10% power
- B. 10% power to 15% power
- C. 15% power to 30% power
- D. 30% power to 40% power

QUESTION: 36

A nuclear power plant is operating at 60% of rated power in the middle of a fuel cycle when a turbine control system malfunction opens the turbine steam inlet valves an additional 5 percent. Which one of the following describes the initial reactor power change and the cause for the power change?

- A. Decrease, because the rate of neutron absorption in the moderator initially increases.
- B. Decrease, because the rate of neutron absorption at U-238 resonance energies initially increases.
- C. Increase, because the rate of neutron absorption in the moderator initially decreases.
- D. Increase, because the rate of neutron absorption at U-238 resonance energies initially decreases.

**USNRC GENERIC FUNDAMENTALS EXAMINATION
JUNE 2004 BWR--FORM A**

QUESTION: 37

Refer to the drawing of four identical tank differential pressure (D/P) level detectors (see figure below).

The tanks are identical and are presently at 2 psig overpressure, the same constant water level, and a temperature of 60°F. They are surrounded by atmospheric pressure. All level detectors have been calibrated and are producing the same level indication. A leak in the top of each tank causes a complete loss of overpressure in both tanks.

Which level detector(s) will produce the lowest level indication?

- A. No. 1 only
- B. No. 2 only
- C. No. 1 and 4
- D. No. 2 and 3

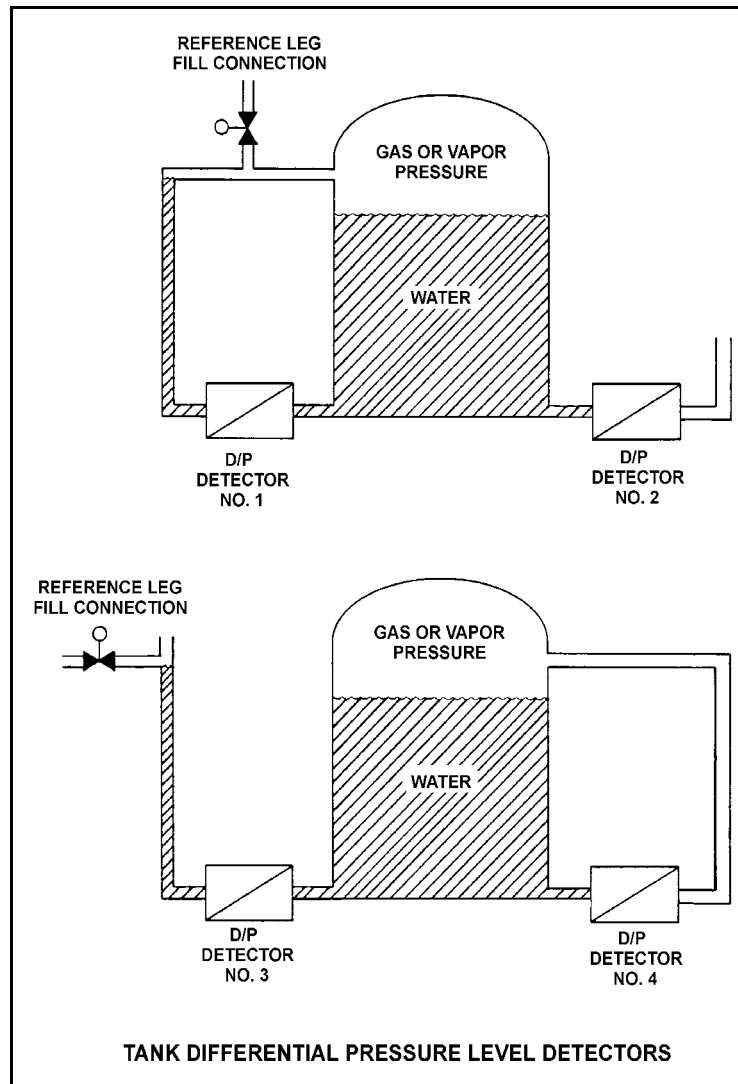

**USNRC GENERIC FUNDAMENTALS EXAMINATION
JUNE 2004 BWR--FORM A**

QUESTION: 38

A 100 ft³ vessel contains a saturated water-steam mixture at 1,000 psia. The water portion occupies 70 ft³ and the steam portion occupies the remaining 30 ft³. What is the approximate total mass of the mixture in the vessel?

- A. 1,547 lbm
- B. 2,612 lbm
- C. 3,310 lbm
- D. 4,245 lbm

QUESTION: 39

A nuclear power plant is operating at 80% of rated power with 5°F of condensate depression in the main condenser. If the condensate depression increases to 10°F, plant efficiency will _____ and the probability of condensate pump cavitation will _____.

- A. increase; increase
- B. increase; decrease
- C. decrease; increase
- D. decrease; decrease

**USNRC GENERIC FUNDAMENTALS EXAMINATION
JUNE 2004 BWR--FORM A**

QUESTION: 40

If the moisture content of the steam supplied to a main turbine increases, (assume no change in steam pressure, condenser pressure, or control valve position) turbine work will...

- A. decrease, because the enthalpy of the steam being supplied to the turbine has decreased.
- B. decrease, because moist steam results in more windage losses in the turbine.
- C. increase, because the enthalpy of the steam being supplied to the turbine has increased.
- D. increase, because moist steam results in less windage losses in the turbine.

**USNRC GENERIC FUNDAMENTALS EXAMINATION
JUNE 2004 BWR--FORM A**

QUESTION: 41

Refer to the drawing of two lengths of 6-inch piping, each containing an identical automatic isolation valve. The actual pipe lengths are proportional to their symbols in the drawing

Water at 65°F is flowing at 1,000 gpm through each pipe. If the isolation valves suddenly and simultaneously close, valve A and its associated piping will experience a maximum pressure that is _____ the maximum pressure experienced by valve B and its associated piping. The pressure spike will dissipate quicker in the _____ length of pipe.

- A. equal to; shorter
- B. equal to; longer
- C. less than; shorter
- D. less than; longer

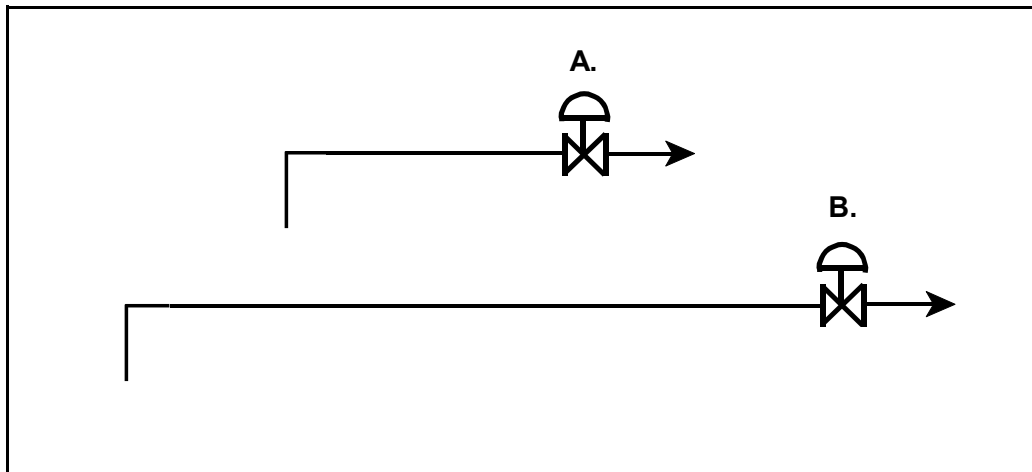

**USNRC GENERIC FUNDAMENTALS EXAMINATION
JUNE 2004 BWR--FORM A**

QUESTION: 42

Which one of the following components of a centrifugal pump has the specific primary function of converting the kinetic energy of a fluid into pressure?

- A. Volute
- B. Impeller
- C. Pump shaft
- D. Discharge nozzle

QUESTION: 43

During a nuclear power plant outage, 6% of the main condenser tubes were plugged. The following 100% power conditions existed before the outage:

Main condenser pressure:	1.10 psia
Cooling water inlet temperature:	60°F
Cooling water outlet temperature:	86°F

After the outage, the plant was returned to 100% power. The following 100% power conditions existed after the outage:

Main condenser pressure:	1.20 psia
Cooling water inlet temperature:	60°F
Cooling water outlet temperature:	?

If the total heat transfer rate in the main condenser is the same, which one of the following will be the approximate final cooling water outlet temperature?

- A. 86°F
- B. 88°F
- C. 90°F
- D. 92°F

**USNRC GENERIC FUNDAMENTALS EXAMINATION
JUNE 2004 BWR--FORM A**

QUESTION: 44

Which one of the following is a characteristic of saturated nucleate boiling but not subcooled nucleate boiling?

- A. T_{Clad} equals T_{Sat}
- B. T_{Clad} is greater than T_{Sat}
- C. $T_{\text{Bulk Coolant}}$ equals T_{Sat}
- D. $T_{\text{Bulk Coolant}}$ is less than T_{Sat}

QUESTION: 45

Following a reactor accident, transition boiling is occurring near the top of one fuel assembly coolant channel. At the coolant channel elevation where the onset of transition boiling is occurring, coolant flow is changing from _____ flow to _____ flow.

- A. annular; slug
- B. annular; vapor
- C. bubbly; slug
- D. bubbly; vapor

**USNRC GENERIC FUNDAMENTALS EXAMINATION
JUNE 2004 BWR--FORM A**

QUESTION: 46

Given:

- Reactors A and B are identical except that reactor A has no core orificing while reactor B is equipped with orifices.
- Both reactors always operate with identical recirculation system flow rates.
- Both reactors are currently operating at 80% of full power with the thermal neutron flux radially peaked in the center of both cores.

Compared to identical locations in the core of reactor A, the critical power ratio (CPR) in the central fuel bundles of reactor B is _____; and the peak power in the peripheral fuel bundles of reactor B is _____.

- A. larger; larger
- B. larger; smaller
- C. smaller; larger
- D. smaller; smaller

QUESTION: 47

If the linear heat generation rate (LHGR) limiting condition for operation is exceeded, the most probable type of fuel failure is cladding...

- A. cracking due to high stress.
- B. gross failure due to a lack of cooling.
- C. embrittlement due to excessive oxidation.
- D. distortion due to inadequate cooling of the clad.

**USNRC GENERIC FUNDAMENTALS EXAMINATION
JUNE 2004 BWR--FORM A**

QUESTION: 48

The fuel thermal time constant describes the amount of time required for...

- A. the fuel to change its rate of heat generation by 63%.
- B. the fuel centerline temperature to undergo 63% of its total change resulting from a given power change.
- C. the fuel cladding temperature to undergo 63% of its total change resulting from a given change in fuel temperature.
- D. reactor power to undergo 63% of its total change resulting from a given reactivity insertion.

QUESTION: 49

Why does the threshold power for pellet-clad interaction decrease as fuel burnup increases?

- A. The fuel pellet thermal conductivity is reduced significantly by irradiation.
- B. The buildup of certain fission product gases causes chemical embrittlement of the cladding.
- C. Fuel pellet densification causes the center of the pellet to expand against the cladding as the pellet length shrinks.
- D. Zirconium hydriding increases significantly as the zirconium oxide layer builds up on the clad.

**USNRC GENERIC FUNDAMENTALS EXAMINATION
JUNE 2004 BWR--FORM A**

QUESTION: 50

Reactor coolant system pressure-temperature limit curves are derived by using an assumed value for the reactor vessel reference temperature for nil ductility transition (RT_{NDT}).

During the first few fuel cycles, the assumed value of RT_{NDT} is _____ than actual RT_{NDT} ; and actual RT_{NDT} is verified periodically over core life by _____.

- A. higher; removing and testing irradiated specimens of reactor vessel material
- B. higher; inservice inspection and analysis of the reactor vessel wall
- C. lower; removing and testing irradiated specimens of reactor vessel material
- D. lower; inservice inspection and analysis of the reactor vessel wall

***** FINAL ANSWER KEY *****

**JUNE 2004 NRC GENERIC FUNDAMENTALS EXAMINATION
BOILING WATER REACTOR - ANSWER KEY**

<u>FORM A</u>	<u>FORM B</u>	<u>ANS.</u>	<u>FORM A</u>	<u>FORM B</u>	<u>ANS.</u>
1	15	D	26	40	D
2	16	B	27	41	A
3	17	B	28	42	B
4	18	C	29	43	A
5	19	D	30	44	B
6	20	B	31	45	C
7	21	C	32	46	C
8	22	D	33	47	B
9	23	B	34	48	A
10	24	C	35	49	B
11	25	C	36	50	B
12	26	D	37	1	D
13	27	D	38	2	C
14	28	A	39	3	D
15	29	D	40	4	A
16	30	B	41	5	A
17	31	C	42	6	A
18	32	A	43	7	B
19	33	A	44	8	C
20	34	B	45	9	B
21	35	A	46	10	B
22	36	D	47	11	A
23	37	C	48	12	C
24	38	C	49	13	B
25	39	B	50	14	A