

An Exelon Company
AmerGen Energy Company, LLC
4300 Winfield Road
Warrenville, IL 60555

www.exeloncorp.com

Nuclear
Exelon Generation
4300 Winfield Road
Warrenville, IL 60555

10 CFR 50.55a

RS-04-065
5928-04-20122
2130-04-20095
April 26, 2004

U. S. Nuclear Regulatory Commission
Attn: Document Control Desk
Washington, DC 20555

Braidwood Station, Units 1 and 2
Facility Operating License Nos. NPF-72 and NPF-77
NRC Docket Nos. STN 50-456 and STN 50-457

Byron Station, Units 1 and 2
Facility Operating License Nos. NPF-37 and NPF-66
NRC Docket Nos. STN 50-454 and STN 50-455

Clinton Power Station
Facility Operating License No. NPF-62
NRC Docket No. 50-461

Dresden Nuclear Power Station, Units 2 and 3
Facility Operating License Nos. DPR-19 and DPR-25
NRC Docket Nos. 50-237 and 50-249

LaSalle County Station, Units 1 and 2
Facility Operating License Nos. NPF-11 and NPF-18
NRC Docket Nos. 50-373 and 50-374

Oyster Creek Generating Station
Facility Operating License No. DPR-16
NRC Docket No. 50-219

Peach Bottom Atomic Power Station, Units 2 and 3
Facility Operating License Nos. DPR-44 and DPR-56
NRC Docket Nos. 50-277 and 50-278

Quad Cities Nuclear Power Station, Units 1 and 2
Facility Operating License Nos. DPR-29 and DPR-30
NRC Docket Nos. 50-254 and 50-265

Three Mile Island, Unit 1
Facility Operating License No. DPR-50
NRC Docket No. 50-289

A047

Limerick Generating Station, Units 1 and 2
Facility Operating License Nos. NPF-39 and NPF-85
NRC Docket Nos. 50-352 and 50-353

Subject: Request for Relief From ASME Section XI for Performance of Class 2 and 3
Raw Water Piping Repairs

Pursuant to 10 CFR 50.55a(a)(3)(i), Exelon Generation Company (Exelon), LLC and AmerGen Energy Company (AmerGen), LLC are requesting relief from American Society of Mechanical Engineers (ASME) Boiler and Pressure Vessel Code, Section XI, "Rules for Inservice Inspection of Nuclear Power Plant Components," on the basis that the proposed alternative provides an acceptable level of quality and safety. Specifically, this proposed alternative concerns the use of Code Case N-661 for Class 2 and 3 plant raw water piping system repairs resulting from degradation mechanisms such as erosion, corrosion, cavitation, or pitting. Copies of the 10 CFR 50.55a request and Code Case N-661 are enclosed.

We request your review and approval of this fleet request by September 30, 2004 in order to support the Fall 2004 outages.

If you have any questions, please contact Tom Loomis, 610-765-5510.

Very truly yours,

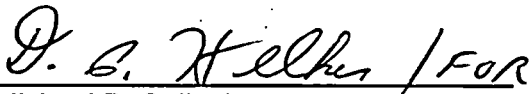

Michael P. Gallagher
Director, Licensing and Regulatory Affairs
Exelon Generation Company, LLC
AmerGen Energy Company, LLC

Enclosures

cc: Regional Administrator – NRC Region I
Regional Administrator – NRC Region III
NRC Project Manager – Braidwood Station
NRC Project Manager – Byron Station
NRC Project Manager – Dresden Nuclear Power Station
NRC Project Manager – LaSalle County Station
NRC Project Manager – Peach Bottom Atomic Power Station
NRC Project Manager – Quad Cities Nuclear Power Station
NRC Project Manager – Clinton Power Station
NRC Project Manager – Oyster Creek Generating Station
NRC Project Manager – Three Mile Island, Unit 1
NRC Project Manager – Limerick Generating Station

ATTACHMENT 1

**Request for Relief From ASME Section XI, IWA-4120(a) of 1989 Edition
(or IWA-4410(a) and (b) of 1995 Edition through 1996 Addenda)
and IWA-4310 of 1989 Edition (or IWA-4611.1 of 1995 Edition
through 1996 Addenda) for Performance of
Class 2 and 3 Raw Water Piping Repairs**

Attachment 1

**10 CFR 50.55a Request
Proposed Alternative
In Accordance with 10 CFR 50.55a(a)(3)(i)
Page 1 of 3**

ASME Code Components Affected

All ASME Class 2 and 3 carbon steel plant raw water piping systems.

Applicable Code Edition and Addenda

<u>PLANT</u>	<u>INTERVAL</u>	<u>EDITION</u>	<u>START</u>	<u>PROJECTED END</u>
Byron Station, Unit 1	Second	1989 Edition, no addenda	June 30, 1996	June 30, 2005
Byron Station, Unit 2	Second	1989 Edition, no addenda	August 16, 1998	August 16, 2007
Braidwood Station, Unit 1	Second	1989 Edition, no addenda.	July 29, 1998	July 28, 2008
Braidwood Station, Unit 2	Second	1989 Edition, no addenda.	October 17, 1998	October 16, 2008
Quad Cities Nuclear Power Station, Units 1 and 2	Fourth	1995 Edition through 1996 Addenda	March 10, 2003	March 9, 2013
LaSalle County Station, Unit 1	Second	1989 Edition, no addenda	November 23, 1994	October 11, 2006
LaSalle County Station, Unit 2	Second	1989 Edition, no addenda	October 17, 1994	July 4, 2007
Clinton Power Station	Second	1989 Edition, no addenda	January 1, 2000	December 31, 2009
Dresden Nuclear Power Station, Units 2 and 3	Fourth	1995 Edition with 1996 Addenda	January 20, 2003	January 19, 2013
Three Mile Island, Unit 1	Third	1995 Edition, 1996 Addenda	April 20, 2001	April 19, 2011
Peach Bottom Atomic Power Station, Unit 2	Third	1989 Edition, no Addenda	November 5, 1998	November 4, 2008
Peach Bottom Atomic Power Station, Unit 3	Third	1989 Edition, no Addenda	August 15, 1998	August 14, 2008
Oyster Creek Generating Station	Fourth	1995 Edition, through 1996 Addenda	October 15, 2002	October 14, 2012
Limerick Generating Station, Units 1 and 2	Second	1989 Edition, no Addenda	January 8, 2000	January 7, 2010

Attachment 1

10 CFR 50.55a Request Proposed Alternative In Accordance with 10 CFR 50.55a(a)(3)(i) Page 2 of 3

Applicable Code Requirement

ASME Code, Section XI, IWA-4120(a) of 1989 Edition (or IWA-4410(a) and (b) of 1995 Edition through 1996 Addenda) requires that repairs be performed in accordance with the Owner's Design Specification/Owner's Requirements and the original or later Construction Code of the component or system.

ASME Code, Section XI, IWA-4310 of 1989 Edition (or IWA-4611.1 of 1995 Edition through 1996 Addenda) requires that the defect be removed or reduced in size in accordance with Article IWA-4000.

Reason for Request

Relief is requested from replacement or internal weld repair of wall thinning conditions resulting from various wall thinning degradation mechanisms such as erosion, corrosion, cavitation, and pitting in Class 2 and 3 carbon steel raw water piping systems in accordance with the design specification/owner's requirements and the original construction code. The primary reason for this request is to provide adequate time for additional examination of adjacent piping so that pipe replacement can be planned to reduce impact on system availability including Maintenance Rule applicability and availability of replacement materials.

Proposed Alternative and Basis for Use

Exelon Generation Company (Exelon), LLC and AmerGen Energy Company (AmerGen), LLC will implement the requirements of ASME Code Case N-661 for Class 2 and 3 plant raw water piping system repairs resulting from degradation mechanisms such as erosion, corrosion, cavitation, or pitting as an alternative to the requirements of IWA-4000. These type defects are typically identified by small leaks in the piping system or by pre-emptive non-code required examinations performed by the Licensee to monitor the degradation mechanisms. The alternative repair technique described in Code Case N-661 involves the application of additional weld metal on the exterior of the piping system, which restores the wall thickness requirement. This repair technique will be utilized whenever engineering evaluation determines that such a repair is suitable for the particular defect or degradation being resolved. Provisions for use of this Code Case will be addressed in the Repair and Replacement Program.

Those provisions will require that adjacent areas be examined to verify that the entire flawed area will be encompassed by the repair and that there are no other unacceptable degraded locations within a representative area dependent on the degradation mechanism present. An evaluation of the degradation mechanism will be performed to determine the re-examination schedule to be performed over the life of the repair. The repair will be considered to have a maximum service life of two fuel cycles unless examinations during each of the two fuel cycles are performed to establish the expected life of the repair.

Additionally, the following restrictions will be placed on the use of Code Case N-661, to assure that the use of the Code Case will provide an acceptable alternative pursuant to 10 CFR 50.55a(a)(3)(i):

- (a) If the cause of the degradation has not been determined, the repair is only acceptable for one cycle.
- (b) Weld overlay repair of an area can only be performed once in the same location.
- (c) When through-wall repairs are made by welding on surfaces that are wet or exposed to water, the weld overlay repair is only acceptable until the next refueling outage.

Attachment 1

10 CFR 50.55a Request Proposed Alternative In Accordance with 10 CFR 50.55a(a)(3)(i) Page 3 of 3

The basis for use of the repair technique described in Code Case N-661 is Section XI of the ASME Code determined this repair technique provides an acceptable alternative to the requirements of IWA-4000 and provides an acceptable level of quality and safety. Therefore, the proposed alternative is justified per 10 CFR 50.55a(a)(3)(i).

Code Case N-661 was approved by the ASME Section XI Code on July 23, 2002; however, it has not been incorporated into NRC Regulatory Guide 1.147 and thus is not available for application at nuclear power plants without specific NRC approval. Therefore, Exelon Generation Company (Exelon), LLC and AmerGen Energy Company (AmerGen), LLC is documenting the request to apply the alternative repair technique described in the Code Case via this relief request. A copy of ASME Section XI Code Case N-661 is attached for reference.

Duration of Proposed Alternative

The proposed alternative is for the use of the remainder of each plant's ten (10) year interval or until the NRC publishes Code Case N-661 in a future revision of the applicable Regulatory Guide.

Precedents

Edwin I. Hatch Nuclear Plant, Units 1 and 2, Joseph M. Farley Nuclear Power Plant, Units 1 and 2, and Vogtle Electric Generating Plant, Units 1 and 2 (TAC Nos. MB8959, MB8960, MB8961, MB8962, MB8963, and MB8964), dated November 21, 2003.

ATTACHMENT 2

**Request for Relief From ASME Section XI for
Performance of Class 2 and 3 Raw Water Piping Repairs**

Code Case N-661

CASES OF ASME BOILER AND PRESSURE VESSEL CODE

Approval Date: July 23, 2002

See Numeric Index for expiration
and any reaffirmation dates.

Case N-661
Alternative Requirements for Wall Thickness
Restoration of Classes 2 and 3 Carbon Steel
Piping for Raw Water Service
Section XI, Division 1

Inquiry: As an alternative to replacement or internal weld repair, what requirements may be applied for wall thickness restoration of Classes 2 and 3 carbon steel raw water¹ piping systems that have experienced internal wall thinning from localized erosion, corrosion, cavitation, or pitting?

Reply: It is the opinion of the Committee that areas of Classes 2 and 3 carbon steel raw water piping experiencing internal wall thinning from localized erosion, corrosion, cavitation, or pitting may have the wall thickness restored externally by means of a weld-deposited carbon or low-alloy steel reinforcement on the outside surface of the piping in accordance with the following requirements. Excluded from these provisions are conditions involving corrosion-assisted cracking or any other form of cracking.

1.0 GENERAL REQUIREMENTS

(a) The wall thickness restoration shall be performed in accordance with a Repair/Replacement Plan satisfying the requirements of IWA-4150.²

(b) The wall thickness restoration shall meet the requirements of IWA-4000,³ except as stated in this Case.

(c) If the minimum required thickness of deposited weld metal necessary to satisfy the requirements of 3.0 is greater than the nominal thickness for the size and schedule of the piping, the provisions of this Case shall not apply. In addition, the total thickness of filler metal applied over multiple repairs shall not exceed the original nominal thickness of the piping.

or brackish/salt water used in plant equipment, area coolers, and heat exchangers. In many plants it is referred to as "Service Water."
²IWA-4140 in the 1989 Edition with the 1991 Addenda through 1995 Edition. IWA-4130 (Repair Program) in the 1989 Edition with the 1990 Addenda and earlier Editions and Addenda.

³IWA-4000/7000 and IWC/IWD-4000/7000, as applicable, in the 1989 Edition with the 1990 Addenda and earlier Editions and Addenda.

⁴IWA-4150 in the 1989 Edition with the 1991 Addenda through

2.0 INITIAL EVALUATION

The material beneath the surface to which the weld overlay is to be applied shall be evaluated to establish the existing average wall thickness and the extent and configuration of degradation to be reinforced by the weld overlay. The adjacent area shall be examined to verify that the repair will encompass the entire defective area. Consideration shall be given to the cause of degradation. The extent of degradation in the piping, shall be evaluated to ensure that there are no other unacceptable locations within the surrounding area that could affect the integrity of the repaired piping. The dimensions of the surrounding area to be evaluated shall be determined by the Owner, considering the type of degradation present. The effect of the repair on the piping, and any remaining degradation shall be evaluated in accordance with IWA-4160.⁴

3.0 DESIGN

3.1 General Design Requirements

(a) Unless otherwise established by theoretical or experimental analysis, or by proof testing as provided for in 3.3 or 3.4, the full thickness of the weld overlay shall extend a distance of at least s in each direction beyond the area predicted, over the design life of the restoration to infringe upon the required thickness.⁵

where

$$s = \geq \frac{3}{4} \sqrt{R t_{\text{nom}}}$$

R = outer radius of the component

t_{nom} = nominal wall thickness of the component

Edges of the weld overlay shall be tapered to the existing piping surface at a maximum angle ("α" in

1995 Edition. IWA-4130 (Repair Program) in the 1989 Edition with the 1990 Addenda and earlier Editions and Addenda.

⁵Design thickness as prescribed by the Construction Code.

⁶IWA-4540 in the 1989 Edition with the 1991 Addenda through

CASES OF ASME BOILER AND PRESSURE VESSEL CODE

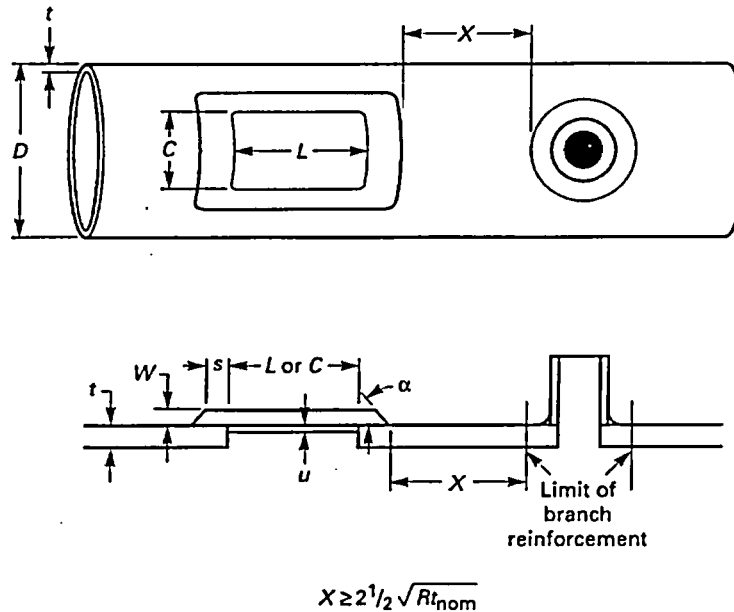

FIG. 1 BRANCH REINFORCEMENT

Fig. 1) of 45 deg. Final configuration of the reinforcement shall permit the examinations and evaluations required herein, including any required preservice or inservice examinations of encompassed or adjacent welds.

(b) The thickness shall be sufficient to maintain required thickness for the predicted life of the repair, and, except for the tapered edges, the overlay shall have a uniform thickness.

(c) The tensile strength of the weld filler metal for the reinforcement shall be at least that specified for the base metal to which it is applied.

(d) The predicted maximum degradation of the overlaid piping and the overlay over the design life of the restoration shall be considered in the design. The predicted degradation of the piping shall be based on in situ inspection and established data for similar base metals. If the weld overlay is predicted to become exposed to the corroding medium, the predicted degradation of the overlay shall be based upon established data for base metals or weld metals with similar chemical composition to that of the filler metal used for the weld overlay.

(e) The effect of weld overlay application on interior coatings shall be addressed in the Repair/Replacement Plan (previously Repair Program).

3.2 Design

The design of weld overlays not prequalified by 3.3, 3.4, or 3.5 shall be in accordance with the applicable requirements of the Construction Code or NC/ND-3100 and NC/ND-3600 (including Appendix II), and shall consider the weld overlay as an integral portion of the piping or component upon which it is applied (not as a weld). The allowable stress values of the base metal shall apply to the design of the deposited weld metal. The following factors shall be considered, as applicable, in the design and application of the reinforcement:

- (a) The shrinkage effects, if any, on the piping;
- (b) Stress concentrations caused by application of the overlay or resulting from existing and predicted piping internal surface configuration;
- (c) If flexibility analysis was required by the original Construction Code, the effect of the weld overlay shall be reconciled with the original analysis. For rectangular-shaped overlays on piping designed to NC/ND-3650 and aligned parallel or perpendicular to the axis of the piping, unless a lower stress intensification factor (SIF or *i*) is established, an SIF (*i*) of 2.1 shall be applied for overlays on straight pipe and adjacent welds. Also, a stress multiplier of 1.7 shall be applied to the SIF (*i*) for standard elbows; and an SIF (*i*) of 2.1 shall be

CASES OF ASME BOILER AND PRESSURE VESSEL CODE

applied for tees and branch connections when the toe of the overlay is not less than $2\frac{1}{2}\sqrt{Rt_{nom}}$ from any branch reinforcement in Fig. 1.

3.3 Proof Test Qualification as a Piping Product

As an alternative to design, the configuration of weld overlays may be qualified by performance of proof testing of a mockup in accordance with the following requirements:

(a) A satisfactory mockup burst test shall qualify the design or configuration for application in the same orientation on the same type of item, and the same location on fittings, when the following conditions are satisfied (see Fig. 1).

(1) The base metal is of the same P-No. and Group Number when impact properties are applicable, as the base metal tested.

(2) The specified minimum tensile strength of the item does not exceed that specified for the base metal tested.

(3) The average thickness of the overlay areas is at least the thickness of the mockup plug, u .

(4) The overlap on the full thickness of base metal, s , is at least that of the mockup.

(5) The transition angle at the outer edges of the overlay, α , is not greater than that of the mockup.

(6) The overlay surface finish is similar to or smoother than that tested.

(7) The maximum proportionate axial dimension, L/D , is not more than that tested.

(8) The maximum proportionate circumferential dimension, C/D , is not more than that tested.

(9) The nominal diameter is not less than one-half nor more than two times the diameter tested.

(10) The nominal thickness/diameter ratio, t/D , is not less than one-half nor more than three times the t/D , ratio tested.

(b) The mockup base shall consist of new base material of similar configuration, or type of item, as the item to be overlaid. A rounded-corner segment of the base material shall be removed to represent the maximum proportionate size (axial dimension of L and circumferential dimension of C) and location of thinning or pitting to be compensated for by the weld overlay. A plug of the same base metal and of uniform thickness, u , which shall not exceed the smallest average thickness on which the overlays will be permanently applied, shall be full-penetration welded around the opening and flush with the outside surface of the piping. Alterna-

tively, an equivalent volume of base metal may be removed from the inside surface of the mockup by machining or grinding, without need for welding in a closure plug.

(c) The mockup weld overlay shall be applied in accordance with the design or specified configuration using the specified weld filler metal. Maximum section thickness at the overlaid opening (weld metal plus base metal plug, or $u + w$) shall not exceed 87½% of the nominal thickness of the piping.

(d) Straight pipe equivalent to a minimum of one pipe diameter, or one-half diameter for piping over NPS 14, shall be provided (butt-welded to the mockup, if necessary) beyond both ends of the overlay. The piping shall be capped, and the completed mockup assembly shall be thoroughly vented and hydrostatically pressure tested to bursting. To qualify the design for general application within the limits of 3.3(a), burst pressure shall not be less than;

$$P = \frac{2tS_{act}}{D_o}$$

where

P = minimum acceptable burst pressure, psi

t = minimum specified thickness (excluding manufacturing tolerances) of the base metal being tested, in.

S_{act} = reported actual tensile strength of the base metal being tested, psi

D_o = outside diameter of the pipe, in.

(e) If flexibility analysis was required by the original Construction Code, the effect of the weld overlay shall be reconciled in accordance with 3.2(c).

3.4 Proof Test Qualification for Specific Applications

As an alternative to design by analysis or proof test qualification as a piping product, the design or configuration of weld overlays may be qualified for limited service conditions using the provisions of NC/ND-6900, "Proof Tests to Establish Design Pressure," except that component hydrostatic testing is not required (other than as required by IWA-4000³). The mockups shall be fabricated and tested in accordance with the provisions of 3.3(b), (c), and (d), and shall be applied in accordance with the provisions and conditions of 3.3(a). The provisions of 3.3(e) shall be met.

N-661

CASES OF ASME BOILER AND PRESSURE VESSEL CODE

3.5 Prequalified Design

Application of weld overlays on straight pipe, portions of tees not less than $2\frac{1}{2}\sqrt{Rt_{nom}}$ from any branch reinforcement in Fig. 1, standard elbows, and associated welds to correct limited degradation shall be exempt from the requirements of 3.2 through 3.4 provided all of the following conditions are satisfied.

- (a) All the requirements of 3.1 apply.
- (b) The provisions of 3.3(e) shall be met.
- (c) The full thickness of weld overlay shall not exceed a maximum axial length of the greater of 6 in. or the outside diameter of the piping.
- (d) The finished overlay shall be circular, oval, full-circumferential or rectangular in shape.
 - (1) For each repair, the maximum dimension compensated by a circular overlay shall not exceed $\frac{2}{3}$ the nominal outside diameter of the piping.
 - (2) Rectangular overlays shall be aligned parallel with or perpendicular to the axis of the piping, and corners shall be rounded with radii not less than the overlay thickness.
 - (3) For oval overlays, the end radii shall not be less than $\frac{3}{4}\sqrt{Rt_{nom}}$, and the axis of the overlay shall be aligned parallel with or perpendicular to the axis of the piping.
- (e) The distance between toes of adjacent overlays shall not be less than t_{nom} .

4.0 WATER-BACKED APPLICATIONS

(a) Manual application of overlays on water-backed piping shall be restricted to P-No. 1 base materials. Welding of such overlays shall use the SMAW process and low-hydrogen electrodes. In addition, the surface examination required in 6.0 shall be performed no sooner than 48 hr after completion of welding. For such overlays consideration should be given to using a temper bead technique similar to that described in IWA-4650.⁶

(b) Piping with wall thickness less than the diameter of the electrode shall be depressurized before welding.

the 1995 Edition. IWE-4200 in the 1986 Edition with the 1988 Addenda through the 1989 Edition with the 1990 Addenda. IWE-4320 in the 1986 Edition with the 1987 Addenda and earlier Editions and Addenda.

⁷IWA-4500 and either IWA-4510 or IWA-4540 in the 1989 Edition

5.0 INSTALLATION

(a) The entire surface area to which the weld overlay is to be applied shall be examined using the liquid penetrant or magnetic particle method, with acceptance criteria in accordance with NC/ND-2500, NC/ND-5300 for the product form (base metal or weld) involved.

(b) If through-wall repairs are required to satisfy the acceptance criteria, or result from application of the weld overlay, they shall be accomplished by sealing with weld metal using a qualified weld procedure suitable for open-root welding. This weld shall be examined in accordance with 5.0(a). In addition, the first layer of overlay over the repaired area shall be examined in accordance with 5.0(a).

(c) Overlay weld metal shall be deposited using a groove-welding procedure qualified in accordance with Section IX and the Construction Code, or Section IX and Section XI, IWA-4610 and either IWA-4620 or IWA-4650.⁷ The qualified minimum thickness specified in the weld procedure does not apply to the weld overlay or associated base metal repairs.⁸

(d) The surface of the weld overlay shall be prepared by machining or grinding, as necessary, to permit performance of surface and volumetric examinations required by 6.0. For ultrasonic examination, a surface finish of 250 RMS or better is required.

6.0 EXAMINATION

(a) The completed weld overlay shall be examined using the liquid penetrant or magnetic particle method and shall satisfy the surface examination acceptance criteria for welds of the Construction Code or NC/ND-5300.

(b) The weld overlay, including the existing piping upon which it is applied, shall be examined to verify acceptable wall thickness.

(c) Weld overlays shall be volumetrically examined as base metal repairs when required by the Construction Code, except as follows:

(1) Weld overlays not exceeding 10 in.² surface area are exempt from volumetric examination.

with the 1991 Addenda through 1995 Edition. IWA-4510 or IWE-4200 in the 1986 Edition with the 1988 Addenda through 1989 Edition with the 1990 Addenda. IWB-4320 or IWE-4320 in the 1986 Edition with the 1987 Addenda or earlier Editions and Addenda.

⁸Exception to IWA-4000.

⁹IWA-3000 and IWB-3514 in the 1989 Edition with the 1990

CASES OF ASME BOILER AND PRESSURE VESSEL CODE

(2) Other weld overlays shall be exempt from volumetric examination when the finished applied thickness (w in Fig. 1) does not exceed:

(a) $\frac{1}{3}t$ for $t \leq \frac{3}{4}$ in.

(b) $\frac{1}{4}$ in. for $\frac{3}{4}$ in. $< t \leq 2\frac{1}{2}$ in.

(c) The lesser of $\frac{3}{8}$ in. or 10% of t for $t > 2\frac{1}{2}$ in.

where

t = finished full-section thickness of compensated area (e.g., $w + u$ in Fig. 1)

When volumetric examination is required, the full volume of the finished overlay, excluding the tapered edges, but including the volume of base metal required for the design life of the overlay, shall be examined using either the ultrasonic or radiographic method, and shall, to the depth at the surface of the existing piping, satisfy the acceptance criteria for weldments of the Construction Code or NC/ND-5300. The volume of the existing piping, beneath the weld overlay, taken credit for in the design, shall satisfy the volumetric acceptance

¹Raw water is defined as water such as from a river, lake, or well

criteria of NC/ND-2500, NC/ND-5300 for the product form, or IWA-3000.⁹

7.0 INSERVICE EXAMINATION

(a) The Owner shall prepare a plan for additional examination to verify that minimum wall thickness is not violated over the life of the repair. The frequency and method of examination shall be determined based on an evaluation of the degradation mechanism.

(b) The maximum expected life of the repair shall be two fuel cycles unless examinations during each of the two fuel cycles are performed to establish the expected life of the repair.

8.0 DOCUMENTATION

Use of this Case shall be documented on an NIS-2 Form.

Addenda and earlier Editions and Addenda.