

# AmerGen<sub>SM</sub>

Telephone No. (609) 971-4652 RM Dept.

An Exelon Company

## DOCUMENT TRANSMITTAL

April 5, 2004

To:  
PETER S TAM-USNRC  
SR. PROJECT MANAGER  
COPY SERIAL #72  
WASHINGTON DC 20555

**PLEASE NOTE: IT IS IMPERATIVE THAT YOU NOTIFY RM OF ADDRESS CHANGES!!**

**FILE INSTRUCTIONS:**

2000-EMG-3200.12 REV 5

**DESTROY OUTDATED:**

2000-EMG-3200.12 REV 4

**FAILURE TO COMPLY WITH REQUIRED ACTION, WITHIN TWO (2) WORKING DAYS OF THIS REQUEST, COULD RESULT IN A CAP.**

- REQUIRED ACTION:**
1. ADD REVISION TO YOUR CONTROLLED COPIES.
  2. DESTROY OUTDATED MATERIAL.
  3. RETURN TRANSMITTAL SIGNED AND DATED.

**SIGN AND RETURN TO: RECORDS MANAGEMENT, OCAB-1**

**NAME:** \_\_\_\_\_ **DATE:** \_\_\_\_\_

**YOUR SIGNATURE ON THIS FORM INDICATES THAT YOU HAVE FILED THE CURRENT REVISION. THIS SIGNED FORM CAN BE USED FOR AUDITING PURPOSES.**

AG5942 (08/02)

A045

<b>AmerGen</b> An Exelon Company	OYSTER CREEK NUCLEAR GENERATING STATION PROCEDURE	Number <b>EMG-3200.12</b>
-------------------------------------	--	------------------------------

Title <b>RADIOACTIVITY RELEASE CONTROL</b>	Revision No. <b>5</b>
---	--------------------------

Applicability/Scope EMERGENCY OPERATING PROCEDURE FOR OYSTER CREEK	Usage Level <b>1</b>	Responsible Department <b>OPERATIONS</b>
		Effective Date

Prior Revision 4 incorporated the following Temporary Changes:  
N/A

This Revision 5 incorporates the following Temporary Changes:  
N/A

LIST OF PAGES (all pgs. rev'd to Rev. 5)  
 1.0 to 2.0  
 E1-1  
 E2-1 to E2-2

OYSTER CREEK  
 CONTROLLED DISTRIBUTION  
 DOCUMENT SERIAL NUMBER 72  
 IRMC

	Signature	Concurring Organization Element	Date
Originator	/s/	EOP COORDINATOR	3/16/04
Concurred By	/s/	EOP COMMITTEE	3/16/04
	/s/	DIRECTOR ENGINEERING	3/20/04
	/s/	PLANT OPERATIONS DIRECTOR	3/22/04
Approved By	/s/	PLANT MANAGER	3/24/04

<b>AmerGen</b>	OYSTER CREEK NUCLEAR GENERATING STATION PROCEDURE	Number <b>EMG-3200.12</b>
Title <b>RADIOACTIVITY RELEASE CONTROL</b>		Revision-No. <b>5</b>
Applicability/Scope EMERGENCY OPERATING PROCEDURE FOR OYSTER CREEK	Usage Level <b>1</b>	Responsible Department OPERATIONS
		Effective Date <b>4/2/04</b>

Prior Revision 4 incorporated the following Temporary Changes:

N/A

This Revision 5 incorporates the following Temporary Changes:

N/A

LIST OF PAGES (all pgs. rev'd to Rev. 5)

1.0 to 2.0  
E1-1  
E2-1

	Signature	Concurring Organization Element	Date
Originator	<i>[Signature]</i>	EOP COORDINATOR	3/16/04
Concurred By	<i>[Signature]</i>	EOP COMMITTEE	3/16/04
	<i>[Signature]</i>	DIRECTOR ENGINEERING	3/25/04
	<i>[Signature]</i>	PLANT OPERATIONS DIRECTOR	3/22/04
Approved By	<i>[Signature]</i>	PLANT MANAGER	3/24/04

Title

**RADIOACTIVITY RELEASE CONTROL**

Revision No.

**5**

1.0 PURPOSE

The purpose of the Radioactivity Release Control Procedure is to limit the radioactivity release into areas outside the Primary and Secondary Containments.

2.0 REFERENCES

2.1 Procedures

- AD-OC-103, EOP-SAM Program Control
- 329, Turbine Bldg. Heating and Ventilation System

2.2 - 2000-GLN-3200.01, OC Plant Specific Technical Guidelines

2.3 - 2000-STD-1218.04, EOP Writer's Guide

3.0 ATTACHMENTS

3.1 Attachment A - Secondary Containment and Radioactivity Release Control EOP Flowchart  
EMG-3200.11 & EMG-3200.12 Rev. 5

3.2 Attachment B - Support Procedure 51, Turbine Building Ventilation Restart

ATTACHMENT A

Attachment A to EMG-3200.12, Radioactivity Release Control, is the Secondary Containment and Radioactivity Release Control EOP Flowchart, EMG-3200.11 & EMG-3200.12 Rev. 5.

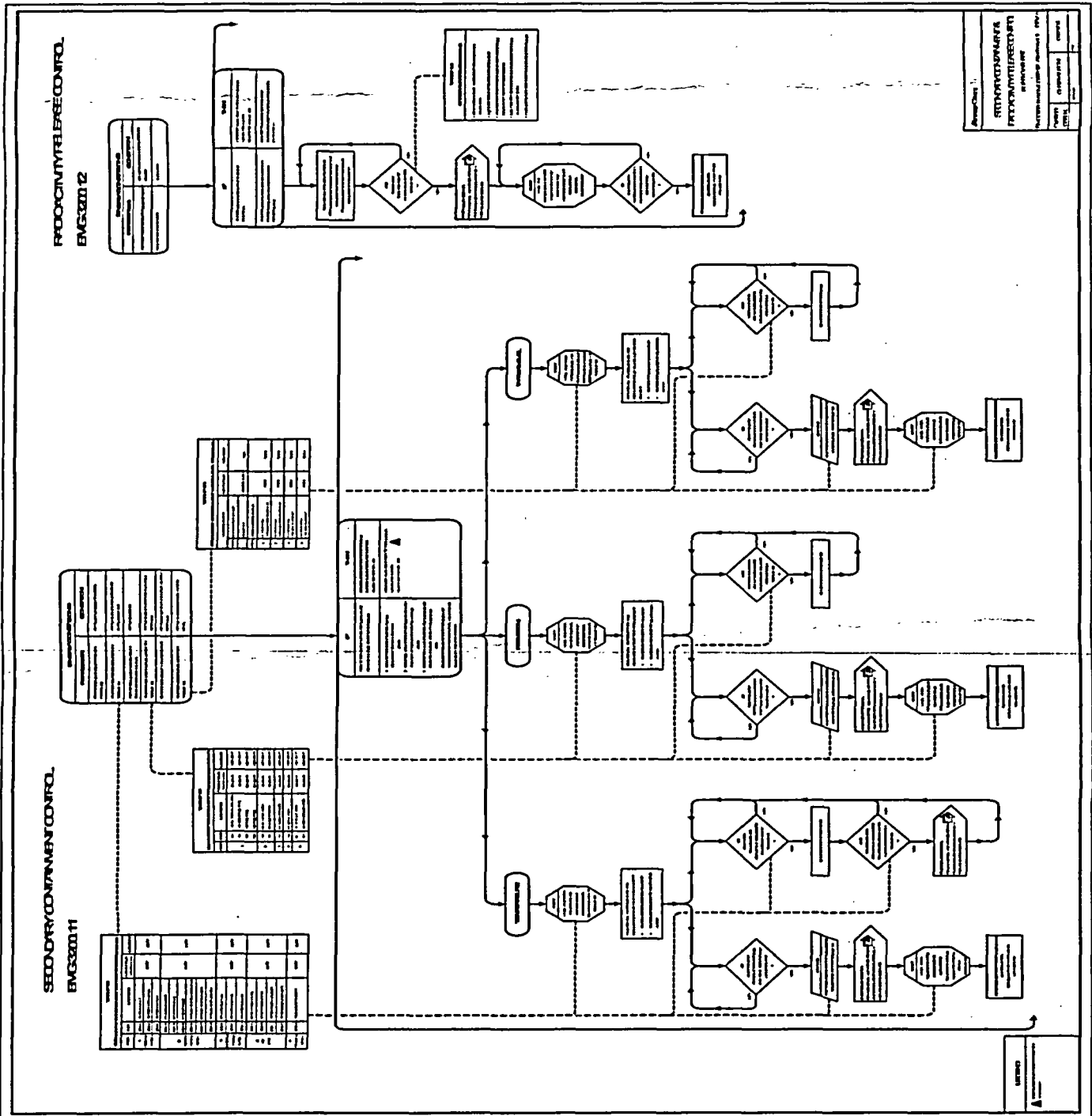

## SUPPORT PROCEDURE 51

### TURBINE BUILDING VENTILATION RESTART

#### 1.0 PREREQUISITES

Operation of Turbine Building Ventilation has been directed by the Emergency Operating Procedures.

#### 2.0 PREPARATION

None.

#### 3.0 PROCEDURE

3.1 Confirm TB Operating Floor Exhaust Fan EF 1-33 secured  
(Panel 11R).

3.2 IF Turbine Building Ventilation is shutdown,  
THEN complete the following:

1. Reset the Turbine Bldg. Ventilation System by momentarily depressing the system RESET pushbutton (Panel 11R).
2. IF Exhaust Fan EF 1-7 was previously running,  
THEN start Exhaust Fan EF 1-7 by placing its control\_switch to START position (Panel 11R).
3. IF Exhaust Fan EF 1-6 was previously running,  
THEN start Exhaust Fan EF 1-6 by placing its control switch to START position (Panel 11R).
4. Select and start either Supply Fan SF 1-1 or SF 1-2 by placing its control switch in the ON position (Panel 11R).
5. Select and start either Supply Fan SF 1-3 or SF 1-4 by placing its control switch in the ON position (Panel 11R).

OVER

Procedure EMG-3200.12

6. Select and start either Supply Fan SF 1-5 or SF 1-6  
by placing its control switch in the ON position  
(Panel 11R). \_\_\_\_\_
7. Verify Exhaust Fan EF 1-4 automatically starts. \_\_\_\_\_
8. Confirm Feed and Condensate Pump Room Supply Fan SF  
1-7 and Exhaust Fan EF 1-1 operating (Panel 11R). \_\_\_\_\_