

# Environmental Impact Statement

# Accelerator Production of Tritium at the Savannah River Site

**UNCLASSIFIED**  
DOES NOT CONTAIN  
UNCLASSIFIED CONTROLLED  
NUCLEAR INFORMATION

ADC & Reviewing Official: Kate Davis Petco  
(Name and Title)  
Date: 3-19-02

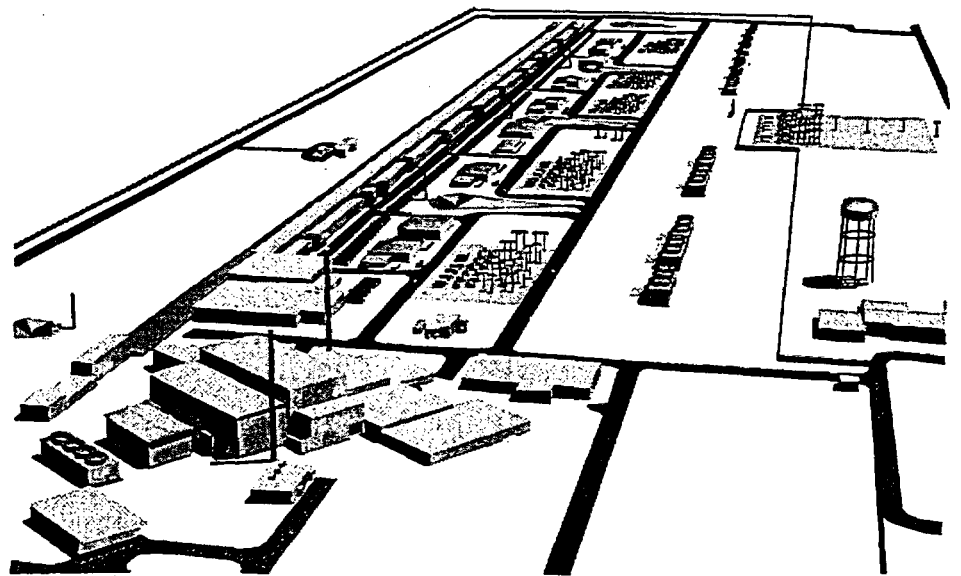

U.S. Department of Energy  
Savannah River Operations Office  
Aiken, South Carolina

**Draft**  
**December 1997**

**UNCLASSIFIED**

UNCLASSIFIED  
EXCEPT WHERE SHOWN  
OTHERWISE

DATE OF REVIEW: 01/11/2011  
BY: [REDACTED]

## COVER SHEET

**RESPONSIBLE AGENCY:** U.S. Department of Energy (DOE)

**TITLE:** Draft Environmental Impact Statement: Accelerator Production of Tritium at the Savannah River Site (DOE/EIS-0270D)

**LOCATION:** Aiken and Barnwell Counties, South Carolina

**CONTACT:** For additional information on this environmental impact statement, write or call:

Andrew R. Grainger  
NEPA Compliance Officer  
U.S. Department of Energy  
Savannah River Operations Office  
Building 773-42A, Room 212  
Aiken, South Carolina 29802  
Attention: Accelerator Production of Tritium EIS  
Local and Nationwide Telephone: (800) 881-7292  
E-mail: nepa@SRS.gov

The EIS is also available on the internet at: <http://www.srs.gov/general/sci-tech/apt/index.html>

For general information on the DOE National Environmental Policy Act (NEPA) process, write or call:

Carol M. Borgstrom, Director  
Office of NEPA Policy and Assistance, EH-42  
U.S. Department of Energy  
1000 Independence Avenue, S.W.  
Washington, D.C. 20585  
Telephone: (202) 586-4600, or leave a message at (800) 472-2756.

**ABSTRACT:** The purpose of the action proposed in this environmental impact statement (EIS) is to construct and operate a linear accelerator that would produce tritium, which is a gaseous radioactive isotope of hydrogen essential to the operation of the weapons in the nation's nuclear arsenal. This EIS is tiered (linked) to the *Final Programmatic Environmental Impact Statement for Tritium Supply and Recycling* (DOE/EIS-0161; October 1995), from which DOE determined that it would produce tritium either in an accelerator as described in this EIS or in a commercial light-water reactor as described in a separate EIS. This EIS evaluates the alternatives for the siting, construction, and operation of an accelerator on the Savannah River Site and the impacts of those alternatives on the Site's physical and manmade environment, its human and biological environment, and the regional economic and social environment.

**PUBLIC COMMENTS:** In preparing this Draft EIS, DOE considered comments received by letter and voice mail, and in comments given at public meetings in Savannah, Georgia, and Aiken, South Carolina, on December 3 and 5, 1996, respectively. (NOTE: These were joint meetings held by DOE to discuss the scopes of two related EISs: this one for the accelerator production of tritium and a proposed EIS for the construction and operation of a Tritium Extraction Facility at the Savannah River Site.) A summary of public comments was made available on April 28, 1997, and may be obtained by contacting Andrew R. Grainger as shown above.

A 45-day comment period on this Draft APT EIS begins with publication of a Notice of Availability in the *Federal Register*. Comments on the Draft EIS must be received by February 2, 1998. A public meeting to discuss and receive comments on the Draft EIS will be held on January 13, 1998, at the North Augusta Community Center, 101 Brookside Drive, North Augusta, South Carolina. Comments may also be submitted by voice, e-mail, or regular mail at the address provided above.



## TABLE OF CONTENTS

<u>Section</u>	<u>Page</u>
SUMMARY .....	S-1
1 BACKGROUND AND PURPOSE AND NEED FOR ACTION .....	1-1
1.1 Background.....	1-1
1.2 Review of the Final Programmatic Environmental Impact Statement for Tritium Supply and Recycling.....	1-3
1.3 Purpose and Need.....	1-4
1.4 SRS Role in Tritium Supply .....	1-4
1.5 Related Department of Energy Actions .....	1-4
1.6 Nonproliferation.....	1-7
1.7 Medical Isotope Production.....	1-7
1.8 Stakeholder Participation.....	1-8
1.9 Organization of the EIS .....	1-9
References .....	1-10
2 PROPOSED ACTION AND ALTERNATIVES.....	2-1
2.1 The Proposed Action and No Action Alternative .....	2-1
2.2 APT Overview .....	2-2
2.3 APT Design Features and Technology Alternatives.....	2-5
2.3.1 Radiofrequency Power Alternatives .....	2-5
2.3.2 Operating Temperature Alternatives.....	2-6
2.3.3 Feedstock Material Alternatives .....	2-7
2.3.4 Cooling Water System Alternatives .....	2-8
2.3.5 APT Site Location Alternatives .....	2-13
2.3.6 Electric Power Supply Alternatives .....	2-16
2.4 Activities Associated with the Proposed Action and Alternatives .....	2-18
2.4.1 Construction and Operation of New Facilities .....	2-18
2.4.2 Use of Existing SRS Facilities to Support APT Operations .....	2-21
2.5 APT Design Variations.....	2-21
2.5.1 Modular or Staged Accelerator Configuration.....	2-21
2.5.2 Increasing Tritium Production.....	2-22
2.5.3 Combining Tritium Extraction Facilities.....	2-23
2.6 Cost and Schedule .....	2-25
2.7 Comparison of Environmental Impacts Among Alternatives .....	2-26
References .....	2-40
3 AFFECTED ENVIRONMENT .....	3-1
3.1 Location of Proposed Actions .....	3-1
3.2 Exposure Pathways .....	3-3
3.3 Physical and Manmade Environment .....	3-6
3.3.1 Landforms, Soils, and Geology.....	3-6
3.3.2 Water Resources .....	3-18

**TABLE OF CONTENTS (continued)**

<u>Sections</u>	<u>Page</u>
3.3.3 Climate.....	3-27
3.3.4 Air Resources.....	3-28
3.3.5 Historic and Archaeological Resources.....	3-30
3.3.6 Site Land Use and Infrastructure.....	3-31
3.3.7 Visual Resources and Noise.....	3-38
3.4 Human and Biological Environment.....	3-39
3.4.1 Human Health.....	3-39
3.4.2 Terrestrial Ecology.....	3-43
3.4.3 Aquatic Ecology.....	3-46
3.4.4 Wetland Ecology.....	3-52
3.4.5 Threatened and Endangered Species.....	3-54
3.5 The Regional Economic and Social Environment.....	3-55
3.5.1 Current Economic Conditions.....	3-55
3.5.2 Current Social Conditions.....	3-56
3.5.3 Projected Economic and Population Conditions.....	3-59
References.....	3-65
4 ENVIRONMENTAL IMPACTS.....	4-1
4.1 Impacts on the Physical and Manmade Environment.....	4-3
4.1.1 Landforms, Soils, Geology, and Hydrology.....	4-3
4.1.2 Surface Water Resources.....	4-5
4.1.3 Air Resources.....	4-11
4.1.4 Land Use and Infrastructure.....	4-22
4.1.5 Waste Management.....	4-23
4.1.6 Visual Resources and Noise.....	4-29
4.2 Impacts on Human and Biological Environment.....	4-32
4.2.1 Human Health.....	4-32
4.2.2 Ecology.....	4-44
4.3 Socioeconomics.....	4-56
4.3.1 Preferred Alternative.....	4-57
4.3.2 APT With Superconducting Alternative.....	4-59
4.3.3 APT With Lithium-6 Feedstock.....	4-62
4.3.4 APT With K-Area Cooling Tower and APT With Once-Through Cooling.....	4-63
4.3.5 Environmental Justice.....	4-63
4.4 Impacts of Electric Power Supply.....	4-66
4.4.1 Electricity from Existing Capacity and Through Market Transactions.....	4-68
4.4.2 Construction and Operation of New Electricity Generating Plant.....	4-69
4.4.3 Comparison of Power Supply Alternatives and Powerplant Options.....	4-79
References.....	4-82

**TABLE OF CONTENTS (continued)**

<u>Sections</u>	<u>Page</u>
5 CUMULATIVE IMPACTS.....	5-1
5.1 Water Resources .....	5-2
5.2 Air Resources .....	5-3
5.3 Waste Generation .....	5-4
5.4 Utilities and Energy.....	5-6
5.5 Public and Worker Health.....	5-8
5.6 Ecological Resources .....	5-8
5.7 Socioeconomics .....	5-10
References .....	5-12
6 RESOURCE COMMITMENTS.....	6-1
6.1 Unavoidable Adverse Impacts.....	6-1
6.2 Short-Term Uses Versus Long-Term Productivity.....	6-1
6.3 Irreversible And Irretrievable Resource Commitments .....	6-2
6.4 Waste Minimization, Pollution Prevention, and Energy Conservation.....	6-3
References .....	6-5
7 APPLICABLE LAWS, REGULATIONS, AND OTHER REQUIREMENTS .....	7-1
7.1 Statutes and Regulations Requiring Permits or Consultations.....	7-1
7.1.1 Environmental Protection Permits.....	7-3
7.1.2 Protection of Biological, Historic, and Archaeological Resources .....	7-6
7.2 Statutes and Regulations Related to Emergency Planning, Worker Safety, and Protection of Public Health and the Environment.....	7-8
7.2.1 Environmental Protection .....	7-8
7.2.2 Emergency Planning and Response .....	7-9
7.3 Executive Orders .....	7-11
7.4 DOE Regulations and Orders .....	7-12
References .....	7-15

LIST OF PREPARERS

GLOSSARY

APPENDIX A - FACILITY AND PROCESS DESCRIPTIONS

APPENDIX B - ACCIDENTS

APPENDIX C - LIST OF PLANTS AND ANIMALS MENTIONED IN THE APT EIS

**TABLE OF CONTENTS (continued)**

**List of Tables**

<u>Tables</u>	<u>Page</u>
S-1 Comparison of impacts among alternatives .....	S-9
2-1 APT site selection criteria.....	2-15
2-2 APT Functions that could be located on the APT site or M-Area .....	2-22
2-3 Comparison of impacts among alternatives .....	2-28
3-1 Summary of soils covering the APT sites .....	3-10
3-2 Hydrogeologic units and associated geologic formations at preferred APT site .....	3-12
3-3 Water-bearing characteristics of the hydrogeologic units beneath the preferred APT site .....	3-13
3-4 Water-bearing characteristics of the hydrogeologic units beneath the alternate APT site .....	3-14
3-5 Water quality in the Savannah River upstream and downstream from SRS (calendar year 1995).....	3-21
3-6 Water quality in SRS streams and Par Pond.....	3-22
3-7 Summary of radiological groundwater quality and field sampling results beneath the preferred APT Site .....	3-26
3-8 Radioactivity in air at the SRS boundary, at the 25-mile radius, and at the 100-mile radius during 1995 (picocuries per cubic meter).....	3-29
3-9 Estimated ambient concentration contributions of air pollutants from existing SRS sources and sources planned for construction or operation through 1995 (micrograms per cubic meter of air) .....	3-30
3-10 Doses to maximally exposed individual during 1995 and comparison to DOE limits (millirem per year) .....	3-42
3-11 SRS annual individual and collective radiation doses .....	3-43
3-12 Comparison of 1996 rates for SRS construction subcontractors and SRS construction to 1995 rates for general industry construction.....	3-44
3-13 Comparison of 1996 rates for SRS operations to 1995 incidence rates for private industry and manufacturing .....	3-44
3-14 Potential Occupational Safety and Health Hazards and Associated Exposure Limits.....	3-45
3-15 Relative abundance (percent) of major taxonomic groups of macroinvertebrates on Hester-Dendy Multiplate Samplers in the Savannah River, 1984-1985 .....	3-50
3-16 Threatened and endangered species of the Savannah River Site .....	3-54
3-17 Population distribution and percent of region of influence for counties and selected communities .....	3-57
3-18 Population projections and percent of region of influence .....	3-58
3-19 General racial characteristics of population in the Savannah River Site region of interest.....	3-60
3-20 General poverty characteristics of population in the Savannah River Site region of interest.....	3-63
4-1 Estimated annual releases (curies) of major radionuclides in liquid discharges from the APT .....	4-6
4-2 Average annual radiological and nonradiological constituents discharged in liquid effluents for the preferred configuration, and percent differences in alternatives to the Preferred alternatives.....	4-7



## TABLE OF CONTENTS (continued)

### List of Tables

<u>Tables</u>	<u>Page</u>
4-3 Monthly discharge temperatures (°F).....	4-8
4-4 Monthly average and maximum water temperatures in Par Pond system from Once-Through Cooling with River Water Alternative (°F).....	4-9
4-5 Monthly solids discharge concentrations (milligrams per liter).....	4-10
4-6 Sources of air emissions for the APT project.....	4-12
4-7 Estimated maximum concentrations (micrograms per cubic meter) of regulated air pollutants at the SRS boundary from construction activities at the preferred APT site.....	4-14
4-8 Estimated maximum concentrations (milligrams per cubic meter) of nonradiological air pollutants regulated by OSHA at hypothetical worker location (640 meters) from construction at the preferred APT site.....	4-15
4-9 Nonradiological air emissions (tons per year) for APT routine operations.....	4-16
4-10 Estimated maximum concentrations of regulated nonradiological air emissions at SRS boundary from APT operations at preferred APT site (micrograms per cubic meter).....	4-17
4-11 Estimated maximum concentrations at hypothetical worker location (2,000 feet) from APT operations of nonradiological air pollutants regulated by OSHA at the preferred APT site (milligrams per cubic meter).....	4-18
4-12 Annual radionuclide emissions from routine operations of the APT facility (curies).....	4-20
4-13 Annual radiological doses from routine radiological air emissions from the APT.....	4-21
4-14 Electric power and water use for APT operations.....	4-24
4-15 Waste generation and impacts comparison for preferred configuration and alternatives.....	4-26
4-16 Waste types, generating activities, and examples.....	4-27
4-17 Impacts on treatment, storage, and disposal facilities for operation of preferred configuration and alternatives.....	4-28
4-18 Peak and attenuated noise levels (in dBA) expected from operation of construction equipment.....	4-30
4-19 Major noise sources during accelerator operations.....	4-31
4-20 Noise impacts by alternative.....	4-33
4-21 Impacts on public and workers from construction of APT facilities.....	4-34
4-22 Impacts on public health from normal operation of APT facilities.....	4-37
4-23 Impacts on worker health from operation of APT facilities.....	4-39
4-24 General information on accidents associated with APT facilities.....	4-41
4-25 Calculated accident consequences for accidents listed in Table 4-24 for preferred APT site.....	4-43
4-26 Estimated annual rates of impingement and entrainment for APT cooling water alternatives.....	4-48
4-27 Temperature requirements of selected fish species of the Savannah River Site.....	4-50
4-28 Comparison of maximum discharge temperatures in Ponds 2 and 5 and temperatures lethal to resident fish species.....	4-51
4-29 Preferred alternative work force.....	4-57
4-30 Rates of growth for economic measures.....	4-61

**TABLE OF CONTENTS (continued)**

**List of Tables**

<u>Tables</u>	<u>Page</u>
4-31 Workforce by alternative .....	4-62
4-32 Annular sector factors for local dose evaluations .....	4-65
4-33 Estimated per capita annual dose for identified communities in 50-mile region .....	4-67
4-34 Comparison of rated capacities .....	4-69
4-35 Water requirements and operating parameters .....	4-71
4-36 Estimated powerplant emission rates (pounds per hour) .....	4-72
4-37 Estimated air quality impacts for coal- and natural-gas-fired powerplants at the Savannah River Site.....	4-72
4-38 Estimated coal-fired solid waste generation.....	4-74
4-39 Coal-fired electricity generating plant work force .....	4-75
4-40 Natural gas-fired electricity generating plant work force .....	4-79
4-41 Projected environmental impacts for APT electric power supply alternatives.....	4-80
4-42 Projected resource consumption for APT electric powerplant options.....	4-81
5-1 Estimated average annual cumulative radiological doses and resulting health effects to offsite population from liquid releases.....	5-3
5-2 Estimated maximum nonradiological cumulative ground-level concentrations of criteria and toxic pollutants (micrograms per cubic meter) at SRS boundary .....	5-4
5-3 Estimated average annual cumulative radiological doses and resulting health effects to offsite population from airborne releases.....	5-5
5-4 Estimated cumulative waste generation from SRS operations (cubic meters).....	5-5
5-5 Estimated average annual cumulative electrical consumption .....	5-7
5-6 Estimated average annual cumulative radiological doses and resulting health effects to offsite population and facility workers.....	5-9
5-7 Cumulative economic and population measure.....	5-11
6-1 Estimated amounts of materials required for construction and operation of an accelerator at the Savannah River Site.....	6-3
7-1 Environmental permits and consultations required by regulation.....	7-2
7-2 DOE Orders and Notices relevant to the accelerator production of tritium.....	7-13

## TABLE OF CONTENTS (continued)

### List of Figures

<u>Figures</u>	<u>Page</u>
1-1 Savannah River Site.....	-
1-2 Estimated tritium inventory and reserve requirements .....	1-2
1-3 NEPA documentation for related DOE actions.....	1-6
2-1 Major steps in the APT process .....	2-3
2-2 Accelerator schematic.....	2-3
2-3 A pictorial representation of tritium production using neutrons generated by spallation. The proton strikes the target atom, which breaks into multiple fragments with the emission of neutrons. The neutrons then strike atoms ( $^3\text{He}$ or $^6\text{Li}$ ), producing tritium and a by-product atom ( $^1\text{H}$ or $^4\text{He}$ ) .....	2-4
2-4 Schematic diagram of the cooling water system alternatives for APT components with approximate water flows. This drawing assumes that the component to be cooled has the potential for radioactive contamination. For nonradioactive systems, the illustrated secondary coolant system would not be present and the final cooling water system would be linked to the primary coolant loop .....	2-9
2-5 Map of the SRS showing existing features that could be used to provide cooling water for the accelerator.....	2-10
2-6 An example of mechanical-draft cooling towers at the SRS. This cooling tower is located in A-Area and has four exhaust areas on top .....	2-11
2-7 Photograph of the K-Area natural-draft cooling tower that was constructed in the early 1990s but never operated.....	2-12
2-8 Preferred and alternate sites for the APT.....	2-14
2-9 Alternatives for supplying electricity to the APT. Existing transmission lines would be used and DOE would obtain power from existing plants and through market transactions or would obtain electricity from a new coal-fired or natural gas-fired plant.....	2-17
2-10 Conceptual layout of APT facilities and structure (LANL 1997).....	2-19
2-11 Staging with extended linac tunnel .....	2-23
2-12 The modular configuration and possible stages of expansion .....	2-24
3-1 M-Area (toward the southeast).....	3-2
3-2 H-Area tritium facilities .....	3-4
3-3 Common exposure pathways for radioactive effluents to reach members of the public.....	3-5
3-4 Land forms, topography, and 100-year floodplain of the preferred and alternate sites .....	3-7
3-5 Soil types at the preferred and alternate APT sites .....	3-9
3-6 Water table elevations and groundwater flow in the water table aquifer at the preferred and alternate sites .....	3-15
3-7 Savannah River Site, showing seismic fault lines and locations of onsite earthquakes and their dates of occurrence .....	3-17
3-8 Regional epicenters of seismic activity .....	3-19
3-9 Savannah River Site, showing 100-year floodplain and major stream systems.....	3-20
3-10 Location of groundwater contamination and waste sites at the Savannah River Site .....	3-25
3-11 Principal SRS facilities, roads, and railroads.....	3-33

**TABLE OF CONTENTS (continued)**

**List of Figures**

<u>Figures</u>	<u>Page</u>
3-12 Electrical distribution system at the Savannah River Site .....	3-34
3-13 Domestic water distribution system at the Savannah River Site.....	3-36
3-14 Wastewater collection system at the Savannah River Site.....	3-37
3-15 Major sources of radiation exposure in the vicinity of the Savannah River Site .....	3-41
3-16 Forest cover of preferred APT site.....	3-47
3-17 Forest cover of alternate APT site.....	3-48
3-18 Distribution of minority population by census tracts in the SRS region of analysis .....	3-61
3-19 Low-income census tracts in the SRS region of analysis .....	3-62
3-20 Projected Regional Employment .....	3-63
3-21 Projected Regional Population .....	3-64
3-22 Projected Regional Total Personal Income, Gross Regional Product, and State and Local Government Expenditures .....	3-64
4-1 An accident resulting in a release of material.....	4-40
4-2 Regional employment differences greater than No Action alternative.....	4-58
4-3 Regional population differences greater than No Action alternative.....	4-58
4-4 Regional total personal income differences greater than No Action alternative.....	4-60
4-5 Gross regional product differences greater than No Action alternative.....	4-60
4-6 State and local government expenditures differences greater than No Action alternative.....	4-61
4-7 Annular sectors around the Savannah River Site .....	4-64
4-8 Community impacts from a unit population dose .....	4-67
4-9 Employment differences for electricity generating and APT Preferred alternatives from No Action alternative.....	4-76
4-10 Population differences for electricity generating and APT Preferred alternatives from No Action alternative.....	4-77
4-11 Total personal income differences for electricity generating and APT Preferred alternatives from No Action alternative .....	4-77
4-12 Gross regional product differences for electricity generating and APT Preferred alternatives from No Action alternative .....	4-78
4-13 State and local government expenditure differences for electricity generating and APT Preferred alternatives from No Action alternative .....	4-78

## ACRONYMS AND ABBREVIATIONS

AAQS	Ambient Air Quality Standard
ALARA	as low as reasonably achievable
ANSP	Academy of Natural Sciences of Philadelphia
APT	Accelerator Production of Tritium
AWQC	ambient water quality criteria
BA	Biological Assessment
BLS	Bureau of Labor Statistics
CEQ	Council on Environmental Quality
CFR	Code of Federal Regulations
CLWR	commercial light-water reactor
CO	carbon monoxide
CSRA	Central Savannah River Area
CTM	Critical Thermal Maxima
dBA	A-weighted decibel
dB	decibel
DOE	U.S. Department of Energy
DOT	U.S. Department of Transportation
EIS	environmental impact statement
EMF	electromagnetic field
EPA	U.S. Environmental Protection Agency
FONSI	Finding of No Significant Impact
FR	Federal Register
GRP	Gross Regional Product
HVAC	heating, ventilation, and air conditioning
ICRP	International Commission on Radiological Protection
MEI	maximally exposed individual
NAAQS	National Ambient Air Quality Standard
NEPA	National Environmental Policy Act
NOI	Notice of Intent
NO <sub>x</sub>	oxides of nitrogen
NPDES	National Pollutant Discharge Elimination System
NWSM	Nuclear Weapons Stockpile Memorandum
O <sub>3</sub>	ozone
OSHA	Occupational Safety and Health Administration

---

PEIS	Programmatic Environmental Impact Statement
PEL	Permissible Exposure Limit
PM <sub>10</sub>	particulate matter smaller than 10 microns
PSD	Prevention of Significant Deterioration
RCRA	Resource Conservation and Recovery Act
ROD	Record of Decision
SCDHEC	South Carolina Department of Health and Environmental Control
SCE&G	South Carolina Electric and Gas Company
SHPO	State Historic Preservation Officer
SO <sub>2</sub>	sulfur dioxide
SO <sub>x</sub>	sulfur oxides
SRS	Savannah River Site
START	Strategic Arms Reduction Treaty
TDS	total dissolved solids
TEF	Tritium Extraction Facility
TSP	total suspended particulates
TWA	time-weighted average
USC	United States Code
USGS	U.S. Geological Survey
VOC	volatile organic compound

**Metric Conversion Chart**

To convert into metric			To convert out of metric		
If you know	Multiply by	To get	If you know	Multiply by	To get
<b>Length</b>					
inches	2.54	centimeters	centimeters	0.3937	inches
feet	30.48	centimeters	centimeters	0.0328	feet
feet	0.3048	meters	meters	3.281	feet
yards	0.9144	meters	meters	1.0936	yards
miles	1.60934	kilometers	kilometers	0.6214	miles
<b>Area</b>					
sq. inches	6.4516	sq. centimeters	sq. centimeters	0.155	sq. inches
sq. feet	0.092903	sq. meters	sq. meters	10.7639	sq. feet
sq. yards	0.8361	sq. meters	sq. meters	1.196	sq. yards
acres	0.0040469	sq. kilometers	sq. kilometers	247.1	acres
sq. miles	2.58999	sq. kilometers	sq. kilometers	0.3861	sq. miles
<b>Volume</b>					
fluid ounces	29.574	milliliters	milliliters	0.0338	fluid ounces
gallons	3.7854	liters	liters	0.26417	gallons
cubic feet	0.028317	cubic meters	cubic meters	35.315	cubic feet
cubic yards	0.76455	cubic meters	cubic meters	1.308	cubic yards
<b>Weight</b>					
ounces	28.3495	grams	grams	0.03527	ounces
pounds	0.4536	kilograms	kilograms	2.2046	pounds
short tons	0.90718	metric tons	metric tons	1.1023	short tons
<b>Temperature</b>					
Fahrenheit	Subtract 32 then multiply by 5/9ths	Celsius	Celsius	Multiply by 9/5ths, then add 32	Fahrenheit

**Metric Prefixes**

Prefix	Symbol	Multiplication Factor
exa-	E	1 000 000 000 000 000 000 = 10 <sup>18</sup>
peta-	P	1 000 000 000 000 000 = 10 <sup>15</sup>
tera-	T	1 000 000 000 000 = 10 <sup>12</sup>
giga-	G	1 000 000 000 = 10 <sup>9</sup>
mega-	M	1 000 000 = 10 <sup>6</sup>
kilo-	k	1 000 = 10 <sup>3</sup>
centi-	c	0.01 = 10 <sup>-2</sup>
milli	m	0.001 = 10 <sup>-3</sup>
micro-	μ	0.000 001 = 10 <sup>-6</sup>
nano-	n	0.000 000 001 = 10 <sup>-9</sup>
pico-	p	0.000 000 000 001 = 10 <sup>-12</sup>
femto-	f	0.000 000 000 000 001 = 10 <sup>-15</sup>
atto-	a	0.000 000 000 000 000 001 = 10 <sup>-18</sup>

# Summary

---

---



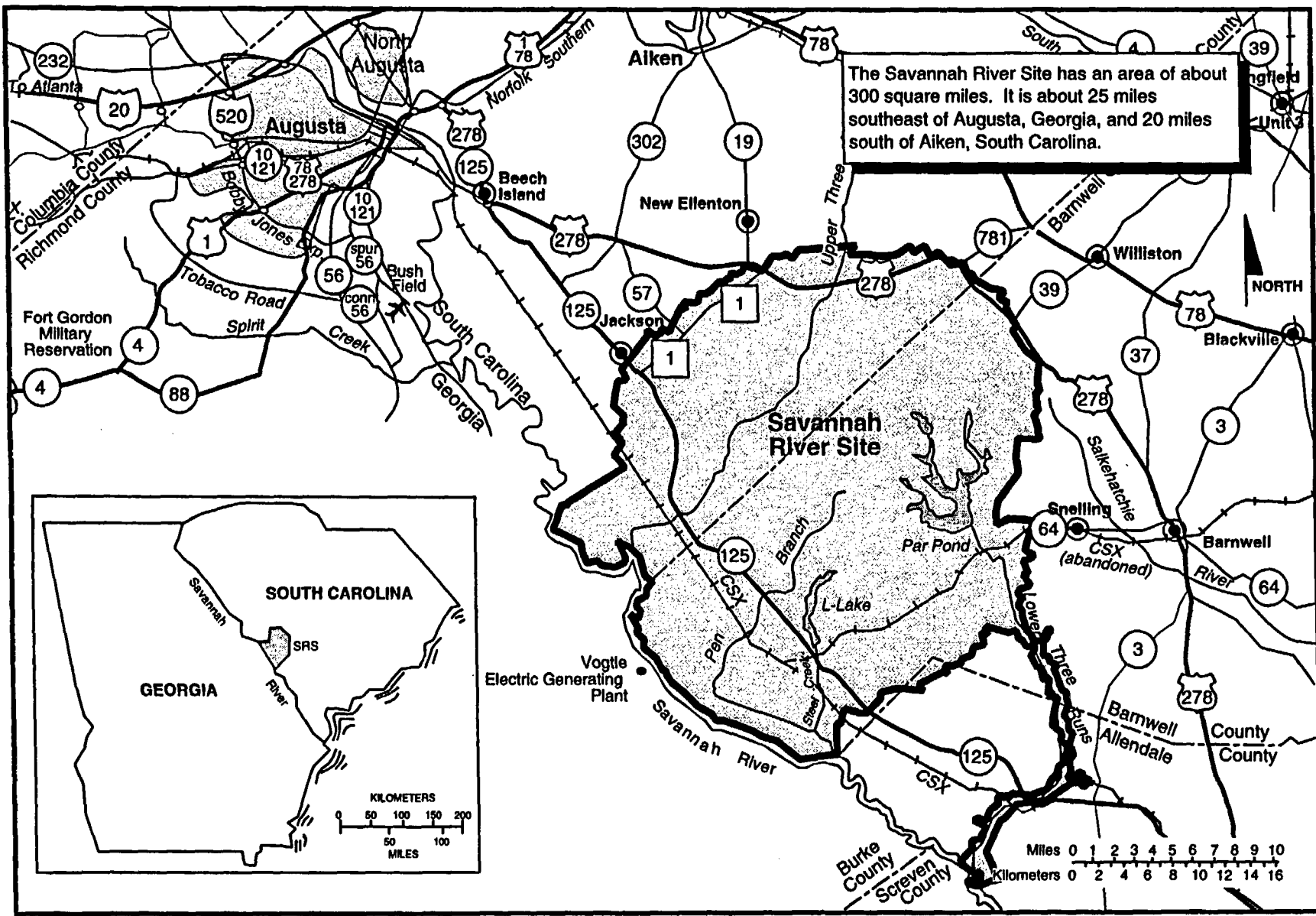

The Savannah River Site has an area of about 300 square miles. It is about 25 miles southeast of Augusta, Georgia, and 20 miles south of Aiken, South Carolina.

## SUMMARY

The U.S. Department of Energy (DOE) is responsible for ensuring that the nation has a supply of materials for the operation of its stockpile of nuclear weapons -- even though a series of treaties has reduced that stockpile to a fraction of what it was during the Cold War. One of these materials is tritium -- a gaseous isotope of hydrogen that increases the yield of nuclear weapons. None of the weapons in the nuclear arsenal would function as designed without tritium.

In other words, as long as the United States chooses to maintain a nuclear deterrent -- of any size -- it will need tritium.

There are two issues related to the United States' need for tritium: The first is that it no longer has operating facilities to produce this material. DOE has shut down the reactors that irradiated the base material from which the gas was derived -- and will not restart them.

The second issue related to tritium is that it decays at a rate of about 5.5 percent per year. This means that present supplies will be cut in half before 2010, and that the United States will run out in about 2040.

Therefore, it is essential that the United States needs a new source of tritium.

For the past several years DOE has been studying how to obtain such a source. Following the requirements of the National Environmental Policy Act (NEPA), the Department took its first step toward a solution with a document titled *Final Programmatic Environmental Impact Statement for Tritium Supply and Recycling* (Tritium Supply PEIS), which evaluated both the need for a new tritium source and the alternatives to provide that source. Continuing the NEPA process, on December 12, 1995, DOE published a Record of Decision (ROD; 60 FR 63878) for the programmatic environmental impact statement (EIS), in which it announced

that it would pursue a dual-track approach to the two most promising alternatives:

- To initiate the purchase of an existing commercial light-water reactor (operating or partially complete) for conversion to a defense facility, or the purchase of irradiation services with an option to purchase the reactor
- To design, build, and test critical components of an accelerator system for tritium production

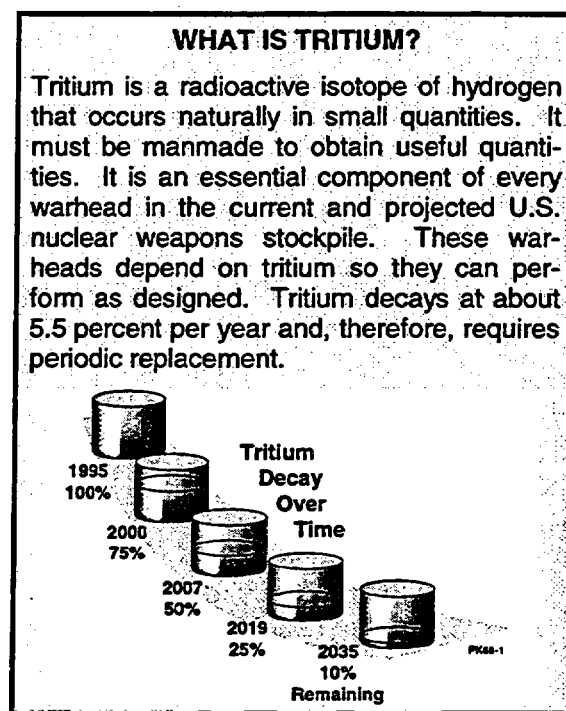

The Record of Decision committed DOE to, within 3 years (by late 1998), selecting one of these approaches to be the primary source of tritium. In addition, the Department would, if possible, continue to develop the other alternative as a backup tritium source. Further, the ROD announced DOE's selection of the Savannah River Site (SRS) in South Carolina as the location for an accelerator, if the Department decided to build one, and its decision to up-

grade and consolidate the existing SRS tritium recycling facilities and to construct a Tritium Extraction Facility at the SRS to support either dual-track alternative.

As a continuation of its NEPA process, DOE developed the following strategy: (1) make decisions on the alternatives described and evaluated in the Tritium Supply PEIS, and (2) tier (link) the Tritium Supply PEIS with site-specific assessments that implement those decisions. Thus, the Department is preparing three documents tiered to the programmatic EIS: this EIS on the construction and operation of an Accelerator for the Production of Tritium (APT), an EIS on the construction and operation of a Tritium Extraction Facility at the SRS, and an EIS on the use of a Commercial Light-Water Reactor to produce tritium.

On September 5, 1996, DOE published the "Notice of Intent To Prepare an Environmental Impact Statement for the Construction and Operation of an Accelerator for the Production of Tritium at the Savannah River Site" (61 FR 46787). As stated in the Notice of Intent, the purpose of this EIS is to evaluate technology and site options for the use of an accelerator for the production of tritium, and to assess the impacts of accelerator construction and operation at the SRS.

**PURPOSE AND NEED FOR ACTION**

The purpose and need for the Department's action is described in the *Programmatic Environmental Impact Statement for Tritium Supply and Recycling*. The Tritium Supply PEIS identified the 1994 Nuclear Weapons Stockpile Plan as the guidance document the Department must follow. Since the issuance of the Tritium Supply PEIS, the President has approved the 1996 Nuclear Weapons Stockpile Plan which is based on START I stockpile levels. The change between the two Nuclear Weapons Stockpile Plans is to change the projection of when a new tritium source is needed from approximately 2011 used in the PEIS to 2005 to 2007 in the 1996 Nuclear Weapons Stockpile Plan. However, the need for tritium for the nuclear weapons stockpile, as discussed in the Tritium Supply PEIS, remains unchanged.

**PROPOSED ACTION AND ALTERNATIVES**

DOE proposes to design, build, and operate a linear accelerator at the Savannah River Site. The Department will use the EIS and the NEPA process to inform decision makers about the potential environmental impacts of the proposed action and alternatives (the estimated impacts of constructing and operating an accelerator to produce tritium are summarized in Table S-1 at the end of this Summary).

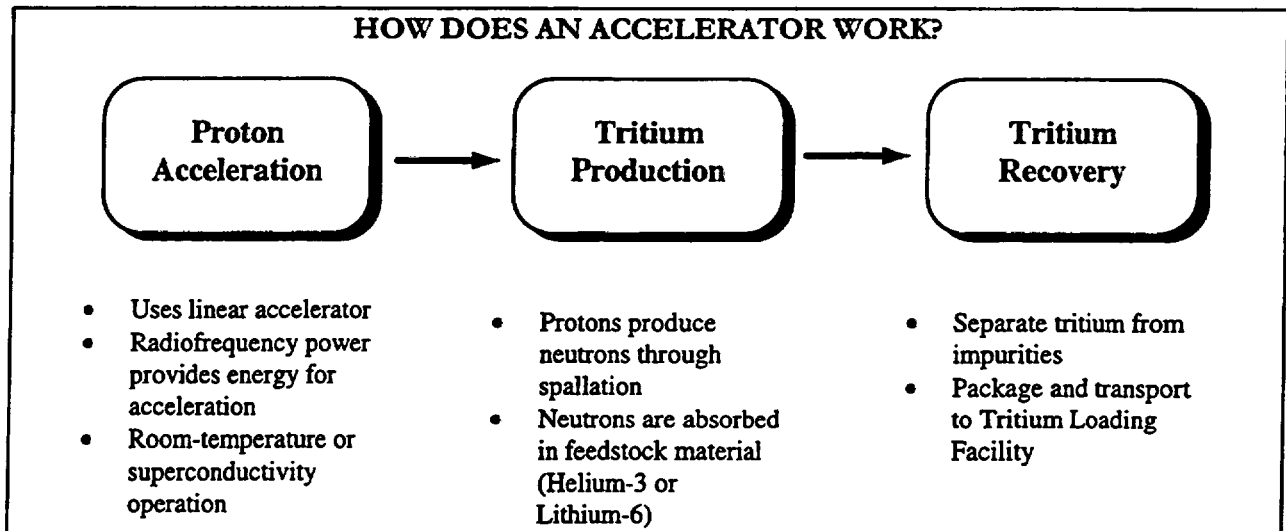

**Preferred Alternative.** Based on the research and development it has performed, DOE proposes the following preferred design and support features for the APT:

- Klystron radiofrequency power tubes
- Superconducting operation of accelerator structures
- Helium-3 feedstock material
- Mechanical-draft cooling towers with river water makeup
- Construction of the APT on a site 3 miles northeast of the Tritium Loading Facility
- Purchase of electricity from existing capacity and market transactions

**No Action Alternative.** In compliance with the regulations of the Council on Environmental Quality (CEQ) for implementing NEPA (40 CFR Part 1500), this EIS also assesses a No Action alternative, under which DOE would defer indefinitely any decision on the final selection of APT design features and would place the research and development information completed at the time it made its decision in an archive. If DOE chose No Action, it would have to meet its tritium production requirements through other methods, or it would not be able to support the long-term defense policies of the United States, which is not acceptable.

Under the No Action alternative, SRS recycling and loading activities related to tritium would continue. In addition, other actions determined in the Record of Decision for the Tritium Supply PEIS -- the potential construction and

### WHAT WOULD AN ACCELERATOR LOOK LIKE?

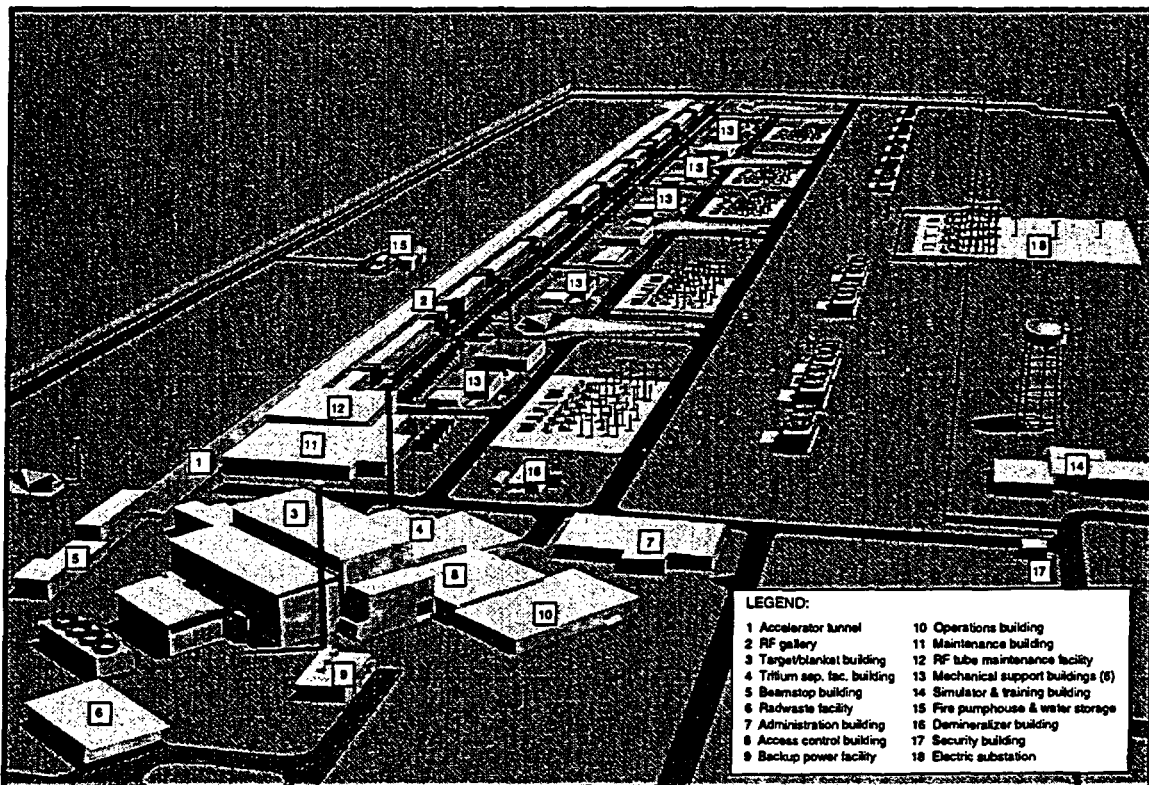

PK68-Z1-PC

*Summary*

operation of a Tritium Extraction Facility and the potential modernization and consolidation of existing SRS tritium facilities -- would proceed as planned.

**DESIGN FEATURES AND SYSTEM ALTERNATIVES***Radiofrequency Power Alternatives*

The APT would use radiofrequency waves to accelerate protons. Specially designed vacuum electron tubes would convert electric power to radiofrequency waves outside the accelerator beam, and waveguides (hollow metal conduits) would transmit them to cells along the beam path. Because radiofrequency waves have both an electric and a magnetic field component, their presence would affect the charged proton beam. The accelerator design would enable the proton beam to intersect the radiofrequency waves at the proper angle to cause acceleration; in other words, the waves would push the protons down the beam tube faster.

Two alternatives could supply radiofrequency power for the accelerator:

- Klystron radiofrequency power tubes (DOE's preference)
- Inductive output radiofrequency power tubes

*Operating Temperature Alternatives*

The operating temperature would affect the electric components of an accelerator, depending on the type and intended use. Electrical resistance usually increases as temperature increases, causing the generation of more heat in the component and resulting in a greater use of electricity. The converse is also true: electrical resistance usually decreases as temperature decreases, causing less heat generation and resulting in less use of electricity. If the temperature of some materials (e.g., niobium) falls to a value very near absolute zero (-459°F), the electrical resistance becomes essentially zero, and the

component uses much less electricity. This phenomenon is superconductivity.

There are two operating temperature alternatives for the design of the accelerator:

- Operating electric components at essentially room temperature
- Operating most components at superconducting temperatures and the rest at room temperature (DOE's preference)

*Feedstock Material Alternatives*

The accelerator would produce protons with an energy greater than 1,000 million electron volts. To produce tritium, the protons would strike a target/blanket assembly of tungsten and lead. The high energy of the protons as they struck the tungsten atoms would cause a phenomenon called spallation in which the atom would emit neutrons. The lead in the target/blanket would be an additional source of neutrons through more spallation events and other nuclear reactions. The neutrons freed during spallation would strike the feedstock material, the atoms of which would undergo a nuclear reaction that absorbed neutrons, resulting in the production of a tritium atom and a byproduct atom.

DOE could use the same type of target/blanket (lead and tungsten) as the neutron source regardless of the feedstock material. The Department has identified two feedstock materials that could produce tritium through the absorption of neutrons produced by spallation events:

- Helium-3 (DOE's preference)
- Lithium-6

*Cooling Water System Alternatives*

The equipment and activities in the APT would generate heat that DOE would have to remove to prevent the components from overheating. Air cooling would keep parts of the APT cool. Other areas would experience high localized temperatures (e.g., the target and blanket re-

### WHAT WOULD COOLING TOWERS LOOK LIKE?

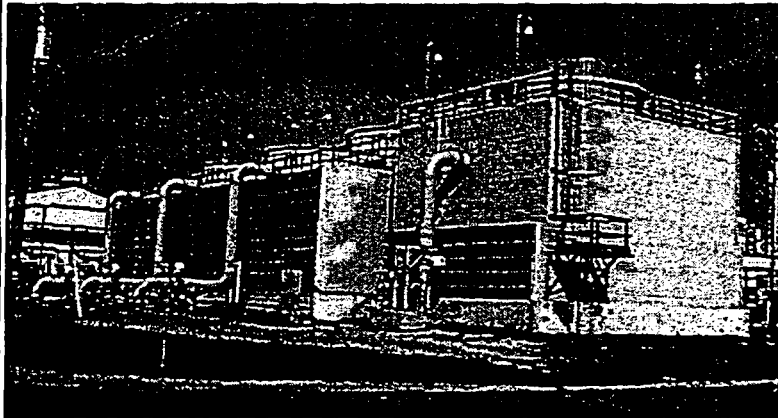

**Mechanical-Draft Cooling Tower**

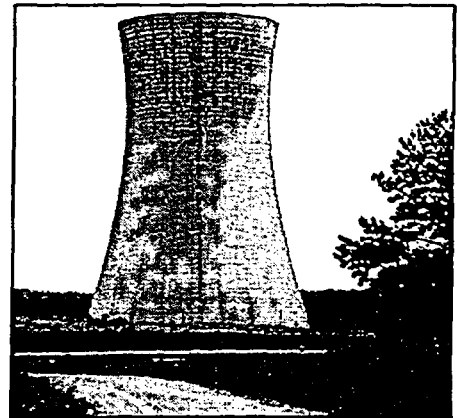

**Natural-Draft Cooling Tower**

gions due to the impingement of the proton beam on the target and the heat generated by radioactive decay in the target/blanket). Those temperatures would require cooling water to keep the target/blanket components, radiation shielding, beamstops, and other components from overheating.

Although these components would not necessarily be connected to the same cooling system, DOE proposes to use a similar method -- a primary coolant loop isolated from the environment through heat exchangers -- to cool each component. The primary coolant loop would be the first system in contact with a component that required cooling, and heat would transfer from the component to the primary coolant loop. Components with a potential for radioactive contamination would require a secondary loop to supply cooling to the primary loop and isolate potential contamination from the environment. The final cooling for the systems, regardless of the number of cooling loops, would use a cooling water system to discharge heat to the environment.

Four cooling water system designs could provide the necessary cooling capacity for the APT:

- Mechanical-draft cooling towers with river water makeup (DOE's preference)

- Mechanical-draft cooling towers with groundwater makeup
- Once-through cooling using river water
- The existing K-Area cooling tower (i.e., natural draft) with river water makeup

#### *APT Design Variations*

There are two potential design variations which could enhance the Department's flexibility to supply the nation's future tritium needs. The first is a modular or staged accelerator configuration. The second is combining tritium separation and tritium extraction facilities.

The modular design variation would use the same accelerator architecture as the baseline accelerator, but would be constructed in stages. The combined tritium separation and tritium extraction facilities would take advantage of common process systems and would be capable of handling both Helium-3 and Lithium-6 feedstock material.

The variations described in the EIS are based on the best information available. This information allows for a preliminary analysis of potential impacts. A more quantified analysis will be included in the final EIS. Based on current

design information, DOE believes potential impacts of the design variations would vary little from those identified for the baseline accelerator.

#### *APT Site Alternatives*

DOE conducted a screening process to select potentially suitable sites for the APT. This multiple-phase process identified areas with a set of suitable features and minimal conflicts with onsite resources and operational areas.

Based on a weighing and balancing of the criteria, DOE selected two sites for further analysis:

- The preferred site 3 miles northeast of the Tritium Loading Facility, and approximately 6.5 miles from the SRS boundary
- The alternate site 2 miles northwest of the Tritium Loading Facility, and approximately 4 miles from the SRS boundary

#### *Electric Power Supply Alternatives*

The APT will require large amounts of electricity (a peak load as high as 600 megawatts-electric for the room temperature alternative) to operate. At present, the SRS obtains its electric power from South Carolina Electric and Gas Company (SCE&G) through existing transmission lines and substations. Both the preferred and alternate APT sites are close to existing electric power supply lines. Due to the projected magnitude of the electrical power usage; however, DOE is studying alternatives for the source of electricity for the APT, and has identified the following two:

- Obtain electricity from existing commercial capacity and through market transactions (DOE's preference)
- Obtain electricity from the construction and operation of a new coal-fired or a natural-gas-fired generating plant

## AFFECTED ENVIRONMENT

DOE would locate the APT on one of two SRS sites. The preferred site is located approximately 3 miles northeast of the existing Tritium Loading Facility, about 6.5 miles from the SRS boundary. The alternate site is located approximately 2 miles northwest of the Tritium Loading Facility, about 4 miles from the SRS boundary. Both sites are 250-acre forested tracts largely dominated by stands of loblolly and slash pine. No threatened or endangered species occur at either site.

Most support activities not located at the APT site would be in M- or H-Area. The following sections describe the proposed APT sites, M-Area, and H-Area.



**APT Sites.** As previously mentioned, DOE used a multiphase screening process to find suitable sites for the APT. This process identified areas with suitable features and minimal conflicts with onsite resources and operational areas.

The first phase involved the identification of land requirements based on the sizes of the proposed facilities. Next came the development of exclusionary criteria to identify areas that could present operational or environmental conflicts with the APT (e.g., locations of threatened or endangered species or seismic faults).

The third phase involved a more detailed comparison, weighing and balancing the sites in four categories: ecology, geology and hydrology, human health, and engineering. DOE evaluated each site against the exclusionary criteria using either quantitative analyses or, if quantitative information was not available, the professional judgment of experts. The site screening process led DOE to the selection of the preferred and alternate sites.

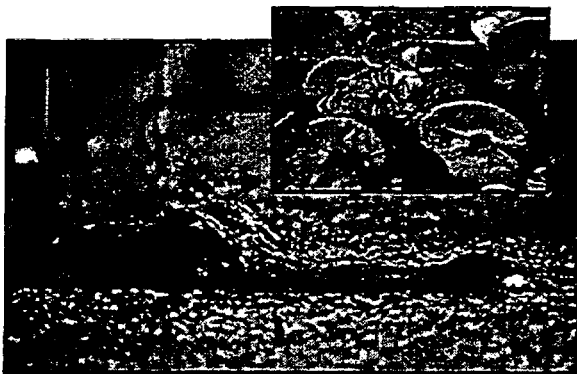

**M-Area.** M-Area, an industrialized area on the SRS, is the proposed host for a number of APT support functions. DOE has declared that several M-Area facilities are surplus and available for new uses. Historically, the Department used M-Area to fabricate fuel, special targets, and components for irradiation in the SRS production reactors. The facilities contain furnaces, extrusion presses, lathes, handling equipment, and storage racks for melting, casting, and shaping metal.

**H-Area.** H-Area is also an industrialized area. At present, the H-Area tritium facilities consist of four buildings, three of which have been part of the historic SRS tritium mission and are second-generation tritium structures. The fourth building, the Tritium Loading Facility (called the Replacement Tritium Facility during its con-

struction and startup) is a third-generation facility that became operational in 1994. Operations in this building include unloading gases from reservoirs returned from the Department of Defense, separating and purifying useful hydrogen isotopes, mixing the gases to exact specifications, and loading the reservoirs.

## Comparison of Environmental Impacts Among Alternatives

Table S-1 presents a comparison of the environmental impacts associated with construction and operation of the baseline APT as a function of alternative. For each technical discipline, the impacts of the Preferred alternative are discussed. The Preferred alternative is composed of the following:

- Klystron radiofrequency power tubes
- Superconducting operation of accelerator structures
- Helium-3 feedstock material
- Mechanical-draft cooling towers with river water makeup
- Electricity from existing capacity and market transactions
- Use of the Preferred APT site

Differences in impacts that could occur if different alternatives were implemented are also presented.

Based on current design information, most of the potential environmental impacts of the two design variations (the modular APT design and combining tritium extraction facilities) are bounded by the baseline APT. In the case of the modular APT design, more land would be required and potential socioeconomic impacts would occur over a greater time period than for the baseline accelerator.



In the case of the modular APT design, however, more land could be required. The potential socioeconomic impacts would initially be less. If the modular APT is expanded to 3 kilograms/year, socioeconomic impacts could extend beyond the construction period assumed for the baseline APT.

In general, DOE considers the expected impacts on the biological, human, and socioeconomic environment of construction and operation of an accelerator for production of tritium at the SRS to be minor and consistent with what might be expected for any industrial facility. Construction and operation of the Preferred alternative would result in the loss of about 250 acres of mixed pine/hardwood upland forest. Waste would be generated during both the construction and operation phases but in quantities that would have negligible impacts on SRS waste management facilities. No high-level waste or transuranic waste would be generated during construction or operation.

Some small impacts from discharge of cooling water to SRS streams and reservoirs and from nonradiological emissions to air and water would occur. Radiological releases during normal operation of the facility are expected to result in no latent cancer fatalities in workers or the public. Because no high or adverse impacts are expected, no disproportionately high or adverse impacts on minority or low-income communities are expected.

Implementation of certain of the technology alternatives could result in impacts different from those resulting from construction and operation of the Preferred alternative. Most notable would be the impacts from implementation of cooling water system alternatives and electric power supply alternatives. Once-Through Cooling Using River Water would result in withdrawal from the Savannah River of

about 125,000 gallons per minute of river water and discharge of heated water to the Par Pond system during operation. Thermal impacts would be restricted to the upper portions of the Par Pond system and would not affect Par Pond discharges to Lower Three Runs. There would be a small increase in Lower Three Runs flows, however. The implementation of the Mechanical-Draft Cooling Towers with Groundwater Makeup alternative would result in the withdrawal of 6,000 gallons per minute of groundwater. Total groundwater withdrawal at the SRS could therefore exceed the estimated groundwater production capacity of the aquifer. This could affect groundwater flow to site streams.

The Preferred alternative includes buying electricity from the commercial grid to support APT operation. In the case of commercial electricity purchases, the environmental impacts attributed to the APT load would be decentralized. In the case of the construction of a new electricity generating plant to support the APT, the environmental impacts would be localized at the site selected for the plant. Construction and operation of such a facility could require about 290 acres for a coal-fired plant and about 110 acres for a gas-fired plant.

Should the Department select the No Action alternative, design work on the APT would be concluded and the information archived. The APT would not be constructed at the preferred site and the 250 acres of land would revert to forestry or other uses. On-going SRS missions would continue. Incremental amounts of waste generation and electricity consumption that would have been attributable to the APT would not occur. Employment would be a function of on-going missions and funding levels.

Table S-1. Comparison of impacts among alternatives.

Preferred alternative	Radio frequency power alternative	Operating temperature alternative	Feedstock material alternative	Cooling water system alternatives			Site location alternative	Electric power supply alternative
Described in text	Inductive output tube	Room temperature	Lithium-6	Once-through using river water as makeup	Mechanical-draft using groundwater as makeup	K-Area cooling tower using river water as makeup	Alternate site	Construct new plant
<b>Impacts from Construction on Landforms, Soils, Geology, and Hydrology</b>								
Negligible impacts. Some 250 acres of land would be graded or leveled. No geologically significant formations or soils occur. Dewatering necessary. No surface faulting on site. Sites for electricity generation exist.	No change estimated from Preferred alternative	No change estimated from Preferred alternative	No change estimated from Preferred alternative	No change estimated from Preferred alternative	No change estimated from Preferred alternative	No change estimated from Preferred alternative	Water table is deeper and would require less dewatering; no other changes estimated from Preferred alternative.	Impacts would depend upon the specific location of a new facility. Could require about 110 acres for natural gas or 290 acres for coal.
<b>Impacts from Operation on Landforms, Soils, Geology, and Hydrology</b>								
No impacts. No dewatering required for operations.	No change estimated from Preferred alternative	No change estimated from Preferred alternative	No change estimated from Preferred alternative	No change estimated from Preferred alternative	Removal of 6,000 gpm on a sustained basis could impact groundwater flow to streams and compact clay layers	No change estimated from Preferred alternative	No change estimated from Preferred alternative	Impacts would depend upon the specific location of a new facility
<b>Impacts from Construction on Surface Water</b>								
Negligible impacts. Dewatering of construction site could result in short-term increases in solids to the receiving water bodies.	No change estimated from Preferred alternative	No change estimated from Preferred alternative	No change estimated from Preferred alternative	No change estimated from Preferred alternative	No change estimated from Preferred alternative	No change estimated from Preferred alternative	No change estimated from Preferred alternative	Impacts would depend upon the specific location of a new facility

S-9

Table S-1. (Continued).

Preferred alternative	Radio frequency power alternative	Operating temperature alternative	Feedstock material alternative	Cooling water system alternatives			Site location alternative	Electric power supply alternative
Described in text	Inductive output tube	Room temperature	Lithium-6	Once-through using river water as makeup	Mechanical-draft using groundwater as makeup	K-Area cooling tower using river water as makeup	Alternate site	Construct new plant
<b>Impacts from Operation on Surface Water</b>								
Blowdown rates (about 2,000 gpm) would cause negligible impact on surface water levels; using Par Pond as discharge point for cooling water. Temperatures would not exceed 90°F. Contaminated sediments would be resuspended in addition to radiological releases from APT.  Estimated fatal cancers: 0.00007	Would require 7% less cooling water than Preferred due to lower waste heat generation; no other changes estimated from Preferred alternative	Would require 33% more cooling water than Preferred; no other changes from Preferred alternative	No change estimated from Preferred alternative	Blowdown rates (about 125,000 gpm) would result in higher temperatures to water bodies (about 100° F). A slight increase in "pre-cooler" pond water levels would occur. No other changes estimated from Preferred alternative.	No change estimated from Preferred alternative	No change estimated from Preferred alternative	No change estimated from Preferred alternative	Discharges would be similar to the Preferred alternative, although concentrations would vary and be localized.
<b>Impacts from Construction on Nonradiological Air Emissions</b>								
Air emissions (fugitive dust and exhaust emissions) would be negligible, well below the applicable regulatory standards, for impacts would be dispersed.	No change estimated from Preferred alternative	No change estimated from Preferred alternative	No change estimated from Preferred alternative	No change estimated from Preferred alternative	No change estimated from Preferred alternative	No change estimated from Preferred alternative	No change estimated from Preferred alternative	Emission types would be similar to the Preferred alternative, although concentrations would vary and be localized.
<b>Impacts from Operation on Nonradiological Air Emissions</b>								
No radiological emissions would be well within the applicable regulatory standards. Operations would result in small amounts of salt deposition and plumes from cooling-tower operations.	No change estimated from Preferred alternative	No change estimated from Preferred alternative	No change estimated from Preferred alternative	No change estimated from Preferred alternative	No change estimated from Preferred alternative	No change estimated from Preferred alternative	No change estimated from Preferred alternative	Nonradiological emissions would be well within applicable regulatory standards.

S-10

Summary

DOE/EIS-0270D  
DRAFT, December 1997

Table S-1. (Continued).

Preferred alternative	Radio frequency power alternative	Operating temperature alternative	Feedstock material alternative	Cooling water system alternatives			Site location alternative	Electric power supply alternative
Described in text	Inductive output tube	Room temperature	Lithium-6	Once-through using river water as makeup	Mechanical-draft using groundwater as makeup	K-Area cooling tower using river water as makeup	Alternate site	Construct new plant
<b>Impacts from Construction on Radiological Air Emissions</b>								
No impacts; no radioactive materials stored during construction.	No change estimated from Preferred alternative	No change estimated from Preferred alternative	No change estimated from Preferred alternative	No change estimated from Preferred alternative	No change estimated from Preferred alternative	No change estimated from Preferred alternative	No change estimated from Preferred alternative	No change estimated from Preferred alternative
<b>Impacts from Operation on Radiological Air Emissions</b>								
Negligible impacts from radioactive airborne effluents  Latent Cancer Fatalities (L.C.F.'s) expected: 0.0006	No change estimated from Preferred alternative	No change estimated from Preferred alternative	Reduced doses from airborne emissions  L.C.F.'s expected: 0.00029	No change estimated from Preferred alternative	No change estimated from Preferred alternative	No change estimated from Preferred alternative	Higher doses from airborne emissions due to closer distance to SRS boundary  L.C.F.'s expected: 0.00065	Impacts would depend upon the specific location of a new facility. However, the dose from radioactive effluents would be negligible.
<b>Impacts from Construction on Land Use and Infrastructure</b>								
Conversion of 250 acres of forested land to industrial use. Additional roads, bridge upgrades, rail lines and utility upgrades would be required.	No change estimated from Preferred alternative	No change estimated from Preferred alternative	No change estimated from Preferred alternative	No change estimated from Preferred alternative	No change estimated from Preferred alternative	Additional cooling water piping to K-area needed.	No change estimated from Preferred alternative	Impacts would depend upon the specific location of a new facility. Could require conversion of up to 290 acres to industrial use.

Table S-1. (Continued).

Preferred alternative	Radio frequency power alternative	Operating temperature alternative	Feedstock material alternative	Cooling water system alternatives			Site location alternative	Electric power supply alternative
Described in text	Inductive output tube	Room temperature	Lithium-6	Once-through using river water as makeup	Mechanical-draft using groundwater as makeup	K-Area cooling tower using river water as makeup	Alternate site	Construct new plant
<b>Impacts from Operation on Land Use and Infrastructure</b>								
No land use changes beyond construction. Electricity use: 3.1 terawatt-hrs	No change estimated from Preferred alternative	No change estimated from Preferred alternative Electricity use 23% higher than Preferred alternative	No change estimated from Preferred alternative	No change estimated from Preferred alternative	No change estimated from Preferred alternative	No change estimated from Preferred alternative	No change estimated from Preferred alternative	No change estimated from Preferred alternative
<b>Impacts from Construction on Waste Management</b>								
Small construction landfill required. Most waste generated would be solid waste and sanitary solid and liquid waste. Waste disposed at SRS.  (Annual Values) Sanitary solid: 560 cubic meters  Construction debris: 30,000 cubic meters	No change estimated from Preferred alternative	9% more waste generated due to greater construction activities required.	No change estimated from Preferred alternative	No change estimated from Preferred alternative	No change estimated from Preferred alternative	No change estimated from Preferred alternative	No change estimated from Preferred alternative	Additional construction waste generated from construction of facility.

Table S-1. (Continued).

Preferred alternative	Radio frequency power alternative	Operating temperature alternative	Feedstock material alternative	Cooling water system alternatives			Site location alternative	Electric power supply alternative
				Once-through using river water as makeup	Mechanical-draft using groundwater as makeup	K-Area cooling tower using river water as makeup		
Described in text	Inductive output tube	Room temperature	Lithium-6	Once-through using river water as makeup	Mechanical-draft using groundwater as makeup	K-Area cooling tower using river water as makeup	Alternate site	Construct new plant
Impacts from Operation on Waste Management								
<p>Would generate solid and liquid wastes, but no high-level or transuranic waste; waste volumes would have negligible impact on capacities of waste facilities.</p> <p>Generation of electricity will generate various types of waste including fly ash, bottom ash, and scrubber sludge.</p> <p>(Annual Values)</p> <p>Sanitary solid: 1,800 metric tons</p> <p>Industrial: 3,800 metric tons</p> <p>Radioactive wastewater: 140,000 gallons</p> <p>High concentration waste Greater-than-Class-C 15 cubic meters</p> <p>Sanitary wastewater: 3.3 million gallons</p> <p>Nonradioactive process wastewater: 920 million gallons</p>	No change estimated from Preferred alternative	37% more nonradioactive process wastewater required.	17% more low-level and 50% more high concentration mixed waste generated than Preferred alternative.	2,000% greater flow of nonradioactive process wastewater required.	No change estimated from Preferred alternative	No change estimated from Preferred alternative	No change estimated from Preferred alternative	Impacts would depend upon the type of power plant selected. However, waste rates for new power plant would not be very different than for the Preferred alternative.
Impacts from Construction on Visual Resources								
Negligible, facilities far from SRS boundaries and not visible to offsite traffic; facilities would look like other industrial areas at SRS.	No change estimated from Preferred alternative	No change estimated from Preferred alternative	No change estimated from Preferred alternative	No change estimated from Preferred alternative	No change estimated from Preferred alternative	No change estimated from Preferred alternative	No change estimated from Preferred alternative	Impacts would depend upon the specific location of a new facility

S-13

Summary

Table S-1. (Continued)

Preferred alternative	Radio frequency power alternative	Operating temperature alternative	Feedstock material alternative	Cooling water system alternatives			Site location alternative	Electric power supply alternative
Described in text	Inductive output tube	Room temperature	Lithium-6	Once-through using river water as makeup	Mechanical-draft using groundwater as makeup	K-Area cooling tower using river water as makeup	Alternate site	Construct new plant
<b>Impacts from Operation on Visual Resources</b>								
Negligible, plumes from mechanical-draft cooling towers would be visible under certain meteorological conditions.	No change estimated from Preferred alternative	No change estimated from Preferred alternative	No change estimated from Preferred alternative	Negligible, would not generate visible plumes.	No change estimated from Preferred alternative	Plume from K-area cooling tower would likely be more visible.	No change estimated from Preferred alternative	Impacts would depend upon the specific location of a new facility
<b>Impacts from Construction on Noise</b>								
Noise primarily from construction equipment at APT site. Not audible at SRS boundaries; however, construction workers could encounter noise levels that would require administrative controls or protective equipment.	No change estimated from Preferred alternative	No change estimated from Preferred alternative	No change estimated from Preferred alternative	No change estimated from Preferred alternative	No change estimated from Preferred alternative	No change estimated from Preferred alternative	No change estimated from Preferred alternative	Noise would be similar to Preferred alternative, but specific impacts would depend upon the location of a new facility
<b>Impacts from Operation on Noise</b>								
Noise from APT equipment operation and traffic; mechanical-draft cooling towers largest single source, not audible at SRS boundary.	No change estimated from Preferred alternative	No change estimated from Preferred alternative	No change estimated from Preferred alternative	No mechanical - draft cooling tower noise at APT site. Pump noise could be occasionally audible to river traffic.	No change estimated from Preferred alternative	No mechanical-draft-cooling tower noise at APT site. Pump and cooling tower noise at K-area.	No change estimated from Preferred alternative	Noise would be similar to Preferred alternative, but specific impacts would depend upon the location of a new facility

Table S-1. (Continued).

Preferred alternative	Radio frequency power alternative	Operating temperature alternative	Feedstock material alternative	Cooling water system alternatives			Site location alternative	Electric power supply alternative
				Once-through using river water as makeup	Mechanical-draft using groundwater as makeup	K-Area cooling tower using river water as makeup		
Described in text	Inductive output tube	Room temperature	Lithium-6	Once-through using river water as makeup	Mechanical-draft using groundwater as makeup	K-Area cooling tower using river water as makeup	Alternate site	Construct new plant
Impacts from Construction on Human Health								
Concentrations of nonradiological constituents would be less than applicable limits for workers and public. Traffic-related accidents resulting in about 2 fatalities to the public and workers due to increased local traffic would be reduced with finish of construction. Occupational injuries to workers would be due to industrial activities and would have the following impacts for the construction period:  Number requiring First Aid: 1,100  Number requiring medical attention: 280  Number resulting in lost work time: 93	No change estimated from Preferred alternative	Occupational injuries 6% less than Preferred alternative	No change estimated from Preferred alternative	No change estimated from Preferred alternative	No change estimated from Preferred alternative	No change estimated from Preferred alternative	No change estimated from Preferred alternative  Traffic fatalities 20% less than Preferred alternative	Impacts would be similar to Preferred alternative, but specific impacts would depend upon the location of a new facility



Table S-1. (Continued).

Preferred alternative	Radio frequency power alternative	Operating temperature alternative	Feedstock material alternative	Cooling water system alternatives			Site location alternative	Electric power supply alternative
Described in text	Inductive output tube	Room temperature	Lithium-6	Once-through using river water as makeup	Mechanical-draft using groundwater as makeup	K-Area cooling tower using river water as makeup	Alternate site	Construct new plant
<b>Impacts from Operation on Human Health</b>								
Public would receive source radiation exposure from APT emissions and transportation of radioactive material; workers would receive radiation exposure from facility operations and transportation of radioactive material and from electromagnetic fields.  Total I.C.I.'s to population (air, water, and transport) 0.0012  Total worker fatal cancers 0.04	No change estimated from Preferred alternative	No change estimated from Preferred alternative	No change estimated from Preferred alternative	No change estimated from Preferred alternative	No change estimated from Preferred alternative	No change estimated from Preferred alternative	No change estimated from Preferred alternative	No change estimated from Preferred alternative. Impacts would be local vs. dispersed for electricity generation.
<b>Impacts from Accidents on Human Health</b>								
Negligible consequences for accidents with frequency of less than once in operating lifetime of facility.	No change estimated from Preferred alternative	No change estimated from Preferred alternative	Minor decreases in accident doses for low probability events.	No change estimated from Preferred alternative	No change estimated from Preferred alternative	No change estimated from Preferred alternative	No change estimated from Preferred alternative	Accident consequences would be reduced since no radioactive material is involved.
<b>Impacts from Construction on Terrestrial Ecology</b>								
Would result in the loss of up to 250 acres of forested land; no marked reduction in plant/animal abundance or diversity.	No change estimated from Preferred alternative	No change estimated from Preferred alternative	No change estimated from Preferred alternative	No change estimated from Preferred alternative	No change estimated from Preferred alternative	No change estimated from Preferred alternative	No change estimated from Preferred alternative	No change estimated from Preferred alternative; specific impacts would depend upon the location of a new facility.

S-16

Table S-1. (Continued).

Preferred alternative	Radio frequency power alternative	Operating temperature alternative	Feedstock material alternative	Cooling water system alternatives			Site location alternative	Electric power supply alternative
Described in text	Inductive output tube	Room temperature	Lithium-6	Once-through using river water as makeup	Mechanical-draft using groundwater as makeup	K-Area cooling tower using river water as makeup	Alternate site	Construct new plant
<b>Impacts from Operation on Terrestrial Ecology</b>								
Negligible impacts. Mechanical-draft cooling towers would result in salt deposition on vegetation; however, maximum rates (60 lb/acres/yr) are below threshold levels (180 lb/acres/yr).	No change estimated from Preferred alternative	No change estimated from Preferred alternative	No change estimated from Preferred alternative	No change estimated from Preferred alternative	No change estimated from Preferred alternative	No change estimated from Preferred alternative	No change estimated from Preferred alternative	Specific impacts would depend upon the location of a new facility
<b>Impacts from Construction on Wetlands Ecology</b>								
No impacts are projected from construction activities.	No change estimated from Preferred alternative	No change estimated from Preferred alternative	No change estimated from Preferred alternative	No change estimated from Preferred alternative	No change estimated from Preferred alternative	No change estimated from Preferred alternative	No change estimated from Preferred alternative	Specific impacts would depend upon the location of a new facility
<b>Impacts from Operation on Wetlands Ecology</b>								
Would result in minor impacts to wetlands. Temperature of the blowdown would be marginally higher than the ambient maximum temperature. During cooler months the warmth could have a positive impact by lengthening the growing season for some aquatic vegetation.	No change estimated from Preferred alternative	No change estimated from Preferred alternative	No change estimated from Preferred alternative	Would raise water level in Ponds 2 and 5 by 1.5 feet, possibly affecting wetland plant communities.	No change estimated from Preferred alternative	No change estimated from Preferred alternative	No change estimated from Preferred alternative	Specific impacts would depend upon the location of a new facility

Table S-1. (Continued).

Preferred alternative	Radio frequency power alternative	Operating temperature alternative	Feedstock material alternative	Cooling water system alternatives			Site location alternative	Electric power supply alternative
Described in text	Inductive output tube	Room temperature	Lithium-6	Once-through using river water as makeup	Mechanical-draft using groundwater as makeup	K-Area cooling tower using river water as makeup	Alternate site	Construct new plant
<b>Impacts from Construction on Aquatic Ecology</b>								
Impacts to aquatic organisms in Upper Three Runs and tributaries would be minor due to use of soil and erosion control measures.	No change estimated from Preferred alternative	No change estimated from Preferred alternative	No change estimated from Preferred alternative	No changes estimated from Preferred alternative.	No change estimated from Preferred alternative	No change estimated from Preferred alternative	No change estimated from Preferred alternative	Specific impacts would depend upon the location of a new facility
<b>Impacts from Operation on Aquatic Ecology</b>								
Impingement (132 fish) and entrainment (173,000 fish eggs and 326,000 larvae annually) would not substantially affect Savannah River fisheries. Solids in blowdown would have no impacts on aquatic ecology. Discharge temperatures would have only small localized effects on aquatic communities.	No change estimated from Preferred alternative	No change estimated from Preferred alternative	No change estimated from Preferred alternative	Impingement (2,600 fish) and entrainment (3.4 million fish eggs and 6.4 million larvae annually) would be increased. Discharge temperatures would be high enough to adversely affect aquatic communities.	No change estimated from Preferred alternative	No change estimated from Preferred alternative	No change estimated from Preferred alternative	Specific impacts would depend upon the location of a new facility
<b>Impacts from Construction on Threatened or Endangered Species</b>								
Negligible, no threatened or endangered species at preferred site.	No change estimated from Preferred alternative	No change estimated from Preferred alternative	No change estimated from Preferred alternative	No change estimated from Preferred alternative	No change estimated from Preferred alternative	No change estimated from Preferred alternative	Negligible, no threatened or endangered species at alternate site.	Specific impacts would depend upon the location of a new facility

S-18

Table S-1. (Continued).

Preferred alternative	Radio frequency power alternative	Operating temperature alternative	Feedstock material alternative	Cooling water system alternatives			Site location alternative	Electric power supply alternative
Described in text	Inductive output tube	Room temperature	Lithium-6	Once-through using river water as makeup	Mechanical-draft using groundwater as makeup	K-Area cooling tower using river water as makeup	Alternate site	Construct new plant
<b>Impacts from Operation on Threatened or Endangered Species</b>								
Negligible impacts to threatened and endangered species.	No change estimated from Preferred alternative	No change estimated from Preferred alternative	No change estimated from Preferred alternative	Fish kills in pre-cooler ponds could be beneficial to bald eagles. Heated discharges could force alligators to leave pre-cooler ponds in late summer.	No change estimated from Preferred alternative	No change estimated from Preferred alternative	No threatened or endangered species at alternate site.	Impacts would depend upon the specific location.
<b>Impacts from Construction on Socioeconomics</b>								
Increases in the work force for API construction would not result in a boom situation.  Peak employment is about 1,400 jobs.	No change estimated from Preferred alternative	Employment would be lower.  Fewer jobs - about 100.	No change estimated from Preferred alternative	No change estimated from Preferred alternative	No change estimated from Preferred alternative	No change estimated from Preferred alternative	No change estimated from Preferred alternative	Peak workforce would be about 1,100 additional no change from Preferred alternative.
<b>Impacts from Operations on Socioeconomics</b>								
Operational work force about 500. No impacts.	No change estimated from Preferred alternative	No change estimated from Preferred alternative	No change estimated from Preferred alternative	No change estimated from Preferred alternative	No change estimated from Preferred alternative	No change estimated from Preferred alternative	No change estimated from Preferred alternative	Additional operational workforce about 200. No impacts.
<b>Impacts from Construction on Environmental Justice</b>								
No adverse impacts on minority or low-income populations expected.	No change estimated from Preferred alternative	No change estimated from Preferred alternative	No change estimated from Preferred alternative	No change estimated from Preferred alternative	No change estimated from Preferred alternative	No change estimated from Preferred alternative	No change estimated from Preferred alternative	Specific impacts would depend upon the location of a new facility.

S-19

Table S-1. (Continued)

Preferred alternative	Radio frequency power alternative	Operating temperature alternative	Feedstock material alternative	Cooling water system alternatives			Site location alternative	Electric power supply alternative
Described in text	Inductive output tube	Room temperature	Lithium-6	Once-through using river water as makeup	Mechanical-draft using groundwater as makeup	K-Area cooling tower using river water as makeup	Alternate site	Construct new plant
Impacts from Operations on Environmental Justice								
No adverse impact on minority or low-income populations expected.	No change estimated from Preferred alternative	No change estimated from Preferred alternative	No change estimated from Preferred alternative	No change estimated from Preferred alternative	No change estimated from Preferred alternative	No change estimated from Preferred alternative	No change estimated from Preferred alternative	Specific impacts would depend upon the location of a new facility.

# Chapter 1

Background and Purpose and Need for Action

---

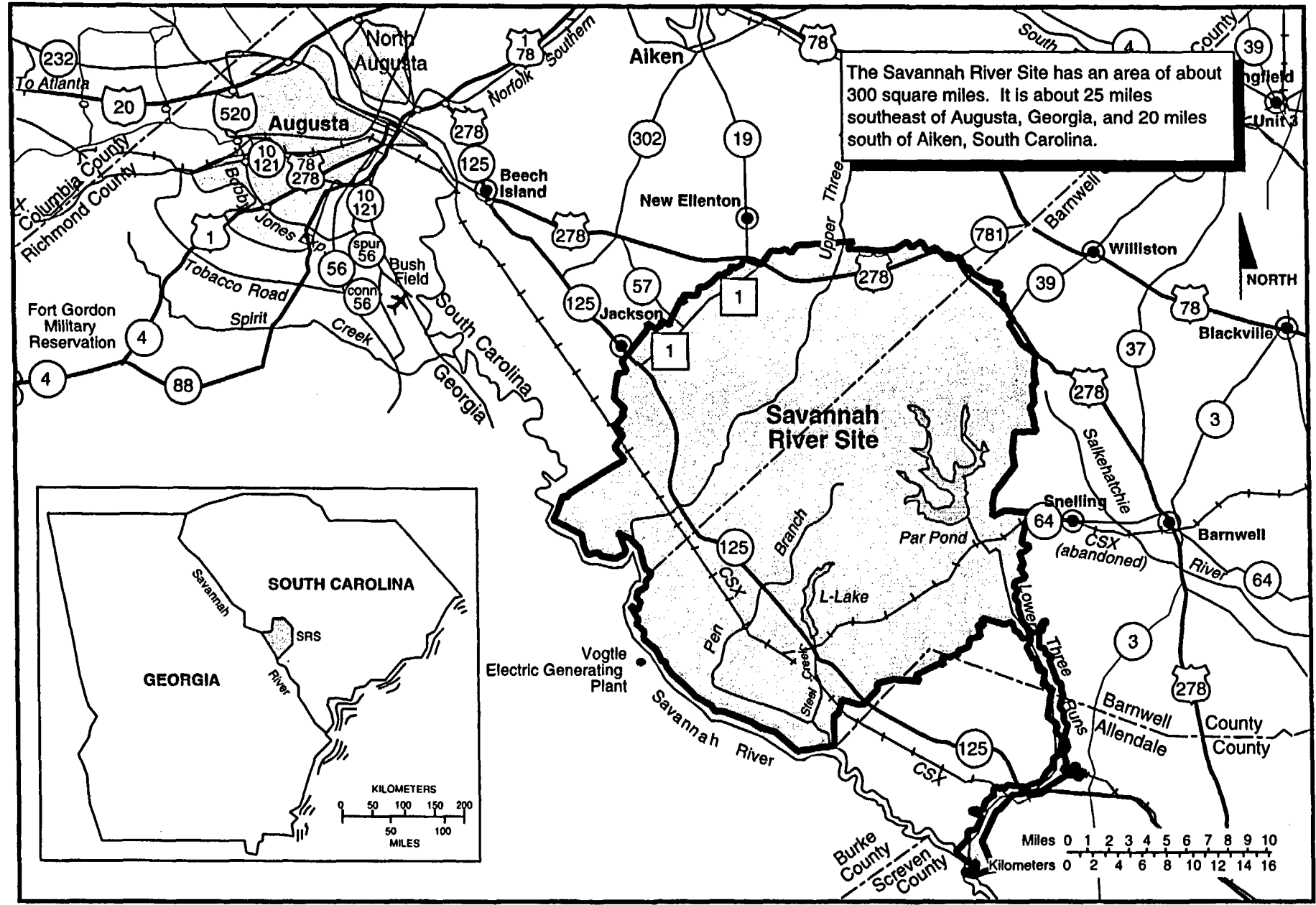

Figure 1-1. Savannah River Site.

PK68-Z1-PC

## CHAPTER 1. BACKGROUND AND PURPOSE AND NEED FOR ACTION

The Department of Energy (DOE) is designing, building, and testing critical components of an accelerator for the production of tritium. If the Department decides to build a production accelerator, it will do so at the Savannah River Site in South Carolina (Figure 1-1). This chapter describes activities that have led to the Proposed Action and Alternatives evaluated in this environmental impact statement. It evaluates the Purpose and Need for this action, and how the capability to produce tritium in an accelerator relates to other ongoing and planned missions at the Savannah River Site.

### 1.1 Background

Since nuclear weapons came into existence in 1945, a nuclear deterrent has been a cornerstone of the Nation's defense policy and national security. President Clinton reiterated this principle in his July 3, 1993, radio address to the Nation. U.S. strategic nuclear systems are based on designs that use tritium, which enhances the yield of nuclear weapons. Because tritium decays over time, new tritium is required to maintain the Nation's nuclear weapons stockpile.

Tritium is a radioactive isotope of hydrogen that occurs naturally in small quantities. It must be manmade to obtain useful quantities. It is an essential component of every warhead in the current and projected U.S. nuclear weapons stockpile. These warheads depend on tritium so they can perform as designed. Tritium decays at about 5.5 percent per year and, therefore, requires periodic replacement.

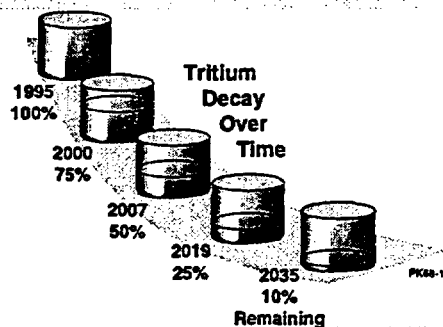

The Nation needs tritium to ensure that each weapon remaining in the stockpile operates as designed. Tritium has a relatively short radioactive half-life of 12.3 years. This rapid decay rate necessitates the periodic replenishment of

tritium in nuclear weapons to ensure that they can function as designed. Over the years DOE built and operated 14 reactors around the country to produce tritium and other nuclear materials. None of the reactors is currently operational, and DOE has not produced tritium since 1988. However, according to the Atomic Energy Act of 1954, DOE is responsible for developing and maintaining the capability to produce nuclear materials such as tritium for the defense of the United States.

Until a new tritium supply source is operational, DOE will continue to support requirements by recycling tritium from weapons retired from the Nation's stockpile. However, because of the tritium decay rate (about 5.5 percent per year), recycling can only meet the tritium demands for a limited time, even with the reduction in stockpile requirements and no identified need for new weapons. Current projections, derived from classified projections of future stockpile scenarios, indicate that recycled tritium will support the Nation's nuclear weapons stockpile adequately until approximately 2005 (see Figure 1-2).

The United States will need a new production source of tritium by 2005. The APT could be available for production in 2007 which means tritium reserves could be utilized in the interim.

Without a new supply source, after 2005 the United States would have to use its strategic reserve, which maintains tritium for emergencies and contingencies, to maintain the readiness of the nuclear weapons stockpile. In such a



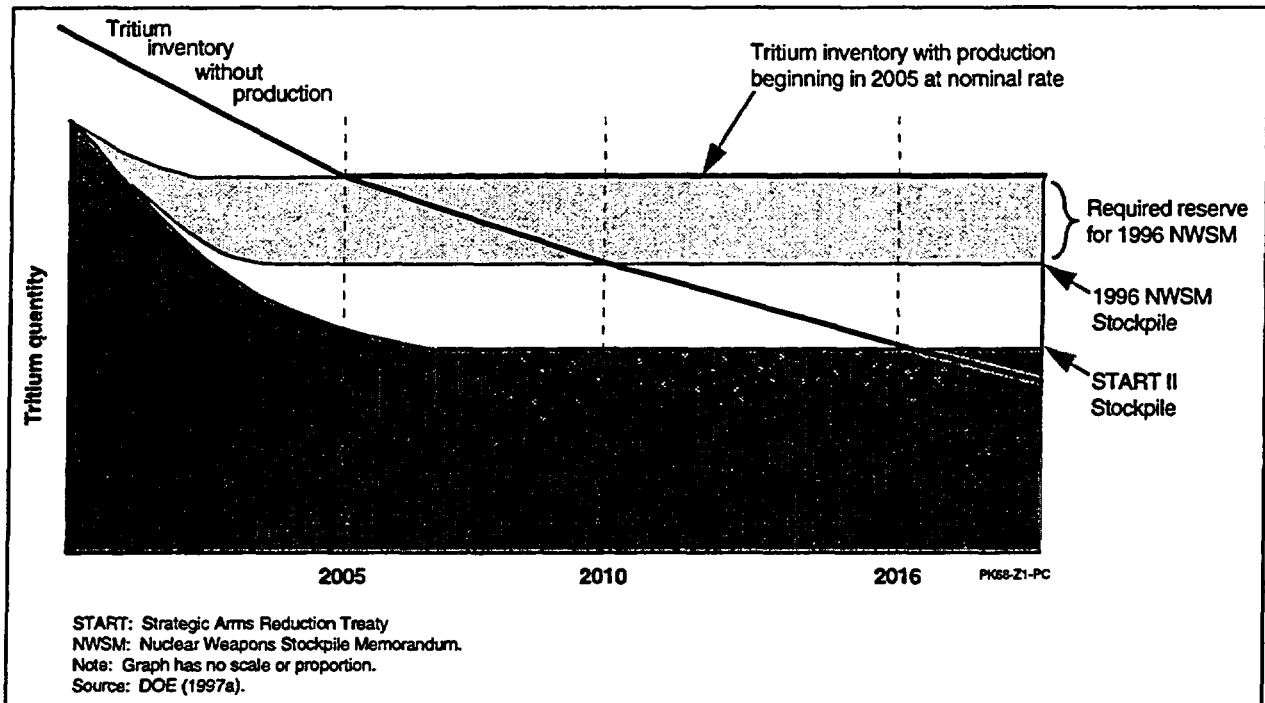

Figure 1-2. Estimated tritium inventory and reserve requirements.

scenario, the depletion of the strategic reserve would degrade U.S. nuclear deterrent capability (based on current designs which require tritium) because some weapons in the stockpile would not be able to function as designed. Eventually, the United States would lose its nuclear deterrent.

In its *Final Programmatic Environmental Impact Statement for Tritium Supply and Recycling* (Tritium Supply PEIS) (DOE 1995), the U.S. Department of Energy evaluated the need for a new tritium source. DOE published a Record of Decision (ROD) for that Programmatic Environment Impact Statement on December 12, 1995 (60 FR 63878). Based on the findings in the Tritium Supply PEIS and on other technical, cost, and schedule evaluations, DOE announced the decision to pursue a dual-track approach to the two most promising alternatives for supplying tritium:

- To design, build, and test critical components of an accelerator system for tritium production

- To initiate the purchase of an existing commercial reactor (operating or partially complete) for conversion to a defense facility, or the purchase of irradiation services with an option to purchase the reactor

In the Record of Decision, DOE committed that it would, within a 3-year period (by late 1998), select one of these approaches to be the primary source of tritium. If feasible, it would continue to develop the other alternative as a backup tritium source. In the interim, testing of critical accelerator components would be performed at the Los Alamos National Laboratory. Further, DOE selected the Savannah River Site (SRS) as the location for an accelerator, if it decides to build one, and decided to upgrade and consolidate the tritium recycling facilities at the SRS and to construct a Tritium Extraction Facility at the SRS to support both dual-track alternatives.

The DOE strategy for compliance with the National Environmental Policy Act (NEPA) has been to (1) make decisions on programmatic

alternatives as described and evaluated in the Tritium Supply PEIS, and (2) follow (tier from the Tritium Supply PEIS) with site-specific assessments that implement the selected programmatic decisions. Following this strategy, DOE is preparing this EIS on the Accelerator for the Production of Tritium (APT), an EIS on the Tritium Extraction Facility, and a Commercial Light Water Reactor EIS. On September 5, 1996, the Department published the "Notice of Intent To Prepare an Environmental Impact Statement for the Construction and Operation of an Accelerator for the Production of Tritium at the Savannah River Site" (61 FR 46787). This EIS evaluates specific technology and site options for the use of an accelerator for the production of tritium at the SRS, and assesses the impacts of accelerator construction and operation.

To support this analysis, DOE is completing an engineering development and demonstration program that will increase technical confidence in those parts of the facility where uncertainties still exist. The descriptions and analyses in this EIS contain the information from this program as it affects the design and anticipated operating parameters of the APT facilities.

DOE proposes specific technology options for an accelerator to be used for the production of tritium at the Savannah River Site.

Also, on September 5, 1996, DOE published a Notice of Intent for the Construction and Operation of a Tritium Extraction Facility at SRS (61 FR 46790). This proposed facility would be able to support either an accelerator or a commercial light-water reactor (CLWR).

The Tritium Supply PEIS is the upper tier document that established the proposed actions described in this follow-up EIS and for the other actions described in Section 1.5, with the exception of the proposed shutdown of the SRS River Water System. This EIS has been prepared consistent with the regulations promulgated by the Council on Environmental Quality (CEQ; see 40 CFR Parts 1502 - 1508). Further,

DOE has prepared this EIS in accordance with Section 102(2)(c) of NEPA as amended (42 USC *et seq.*) and implemented by the CEQ regulations (40 CFR 1500-1508) and the DOE NEPA regulations (10 CFR 1021).

DOE has placed copies of the *Final Programmatic Environmental Impact Statement for Tritium Supply and Recycling* in its Public Reading Rooms. The reading room for the Savannah River Site is at the Gregg-Graniteville Library, University of South Carolina-Aiken Campus, Aiken, South Carolina 29801, 803-641-3465. Interested persons can obtain copies by calling 1-800-881-7292 or writing to: Andrew R. Grainger, U.S. Department of Energy, Savannah River Operations Office, Aiken, South Carolina 29802.

## 1.2 Review of the Final Programmatic Environmental Impact Statement for Tritium Supply and Recycling

In the Tritium Supply PEIS, DOE evaluated facilities that will safely and reliably fulfill future national defense requirements for tritium. As used in the title, "Supply" means the production of new tritium in either a reactor or an accelerator (by irradiating target materials with neutrons) and the subsequent extraction of the tritium in pure form for use in weapons. "Recycling" means recovering residual tritium from weapons components, purifying it, and refilling the components with both recovered and new tritium (when it becomes available).

DOE evaluated four tritium supply technologies for new tritium supply facilities: a Heavy-Water Reactor, a Modular High-Temperature Gas-Cooled Reactor, an Advanced Light-Water Reactor, and an accelerator. The Tritium Supply PEIS included a commercial light water reactor option that evaluated existing commercial light-water reactors for irradiation services or for purchase and conversion to tritium production. The Tritium Supply PEIS also addressed the impacts of a reactor used for the multiple purposes of producing tritium, burning plutonium,

and generating revenues through the sale of electric power (the "triple-play" reactor).

The Tritium Supply PEIS evaluated the siting, construction, and operation of each alternative and recycling facility at five DOE sites: the Idaho National Engineering Laboratory, the Nevada Test Site, the Oak Ridge Reservation, the Pantex Plant, and the Savannah River Site. The tritium recycling facilities process and recycle tritium for use in nuclear weapons; this includes emptying reservoirs returned from weapons in the stockpile, recovering and purifying the tritium, reclaiming reusable reservoirs, providing new gas mixtures, and refilling reservoirs. The facilities also test reservoirs and provide appropriate waste management activities.

In the Record of Decision for the Tritium Supply PEIS, DOE decided that, if it placed the tritium supply and recycling facilities at any site other than the SRS, it would also build new recycling facilities at that site. On the other hand, if the Department decided to put the tritium supply mission at the SRS, it would upgrade the existing facilities there (see Section 1.4).

In the Tritium Supply PEIS, the Department evaluated locating the new tritium supply facilities at one of the five sites mentioned above or at a commercial reactor site. The Department did not evaluate a specific reactor site. In the ROD for the Tritium Supply PEIS, the Department decided the SRS would be the location of the accelerator, if it selected that option.

### 1.3 Purpose and Need

The purpose and need for the Department's action is described in the *Final Programmatic Environmental Impact Statement for Tritium Supply and Recycling* (DOE 1995). The Tritium Supply PEIS identified the 1994 Nuclear Weapons Stockpile Plan as the guidance document the Department must follow. Since the issuance of the PEIS, the President has approved the 1996 Nuclear Weapons Stockpile Plan which is based on START I stockpile levels. The change between the two Nuclear Weapons Stockpile

Plans is to change the projection of when a new tritium source is needed from approximately 2011 used in the PEIS to 2005 to 2007 in the 1996 Nuclear Weapons Stockpile Plan. However, the need for tritium for the nuclear weapons stockpile, as discussed in the PEIS, remains unchanged.

### 1.4 SRS Role in Tritium Supply

The SRS has supported Defense Program activities since it became operational in 1953; the Site has been the center for U.S. tritium production and recycling. The SRS complex for the production of nuclear materials, including tritium, consisted of five reactors, a fuel and target fabrication plant, two chemical separation plants, a tritium-target processing facility, a heavy water rework facility, and waste management facilities. In 1993, DOE put the last operational reactor (K-Reactor) in cold standby with no plan or provision for restart, thereby ending the Nation's capability to produce tritium.

The SRS is continuing to support stockpile requirements with its recycling operation using retired weapons as the tritium source. The SRS facilities empty tritium from retired reservoirs, purify it, and fill replacement reservoirs with tritium for stockpile weapons. DOE then delivers the filled reservoirs to the Pantex Plant near Amarillo, Texas, for weapons assembly, or to the military for placement in weapons in the stockpile.

SRS tritium recycling activities occur primarily in H-Area. If DOE built an accelerator for the production of tritium, it would be on a preferred site approximately 3 miles northeast of H-Area, or on an alternate site north of Upper Three Runs between Roads F and 2, approximately 2 miles northwest of H-Area.

### 1.5 Related Department of Energy Actions

In January 1991, the Secretary of Energy announced that DOE would prepare a program-

matic EIS to examine alternatives for the re-configuration of the Nation's Nuclear Weapons Complex. The Department described the framework for that EIS in its *Nuclear Weapons Complex Reconfiguration Study* (DOE 1991), a detailed examination of alternatives for the proposed Complex.

Due to significant changes since January 1991, especially in relation to projected requirements for the U.S. nuclear weapons stockpile, the framework described in the *Nuclear Weapons Reconfiguration Study* no longer exists. To keep pace with the changes, DOE separated the Reconfiguration Programmatic EIS into the *Final Programmatic Environmental Impact Statement for Tritium Supply and Recycling* (Tritium Supply PEIS) (DOE 1995) and the *Stockpile Stewardship and Management Programmatic EIS* (DOE 1996a). Chapter 1 of the Tritium Supply PEIS discusses the evolution of this program.

As mentioned in Section 1.1, the Record of Decision supported by the Tritium Supply PEIS has resulted in a series of actions by DOE which require site-specific evaluation under the National Environmental Policy Act. These actions are the APT described in this EIS, the purchase or use of a commercial light water reactor to make tritium, the construction of a new tritium extraction facility at SRS, and the upgrade and consolidation of SRS tritium facilities. In addition, the shutdown of the river water system at SRS is related to cooling water alternatives in this EIS. Because of the relationships of these various proposed actions to tritium supply and recycling DOE is closely coordinating the range of proposed actions.

The following sections describe the DOE NEPA implementation strategy including the NEPA documents which it intends to prepare.

**NEPA Implementation Strategy:** Chapter 2 presents the Proposed Action and Alternatives for the APT. These alternatives focus on various technologies and site locations on the Savannah River Site. In a separate environmental impact statement, the DOE is evaluating alternatives for a new tritium extraction facility

(TEF). An additional alternative to those discussed in the TEF EIS would modify the APT to include the equipment needed for TEF operations in the APT. This alternative is described in Section 2.5.3 of this EIS.

DOE proposes to make one or more records of decision to select technology alternatives and a site for the APT. These decisions would be based on the environmental analysis contained in this EIS and policy, technical, cost, and schedule information.

A separate record of decision would select the TEF alternative and would be based on the environmental analysis in the TEF EIS and the environmental analysis on combining the TEF facilities into the APT presented in this EIS. Policy, technical, cost, and schedule information would also be used in this decision.

DOE will prepare an EIS for the commercial light water reactor and has prepared an EIS for the shutdown of the river water system. DOE proposes to make one or more records of decision based on each of these EISs. The upgrade and consolidation of tritium facilities will be evaluated in an environmental assessment followed by a finding of no significant impact or an EIS. The key milestones and status of each of these documents is presented in Figure 1-3.

**Commercial Light Water Reactor(s).** As it is for this document, the Tritium Supply PEIS is also the upper-tier document for the EIS that DOE will prepare on the potential use of a commercial reactor as the primary source of tritium production. The CLWR EIS will assess the environmental differences of producing tritium in commercial reactors. Among its alternatives, that EIS will consider the purchase of an existing or partially completed reactor and the purchase of irradiation services. Further, the Record of Decision for the Tritium Supply and Recycling Programmatic EIS provides guidance for DOE in the preparation of the CLWR EIS and this APT EIS.

If the Secretary selects the commercial light-water reactor option, DOE would transport the

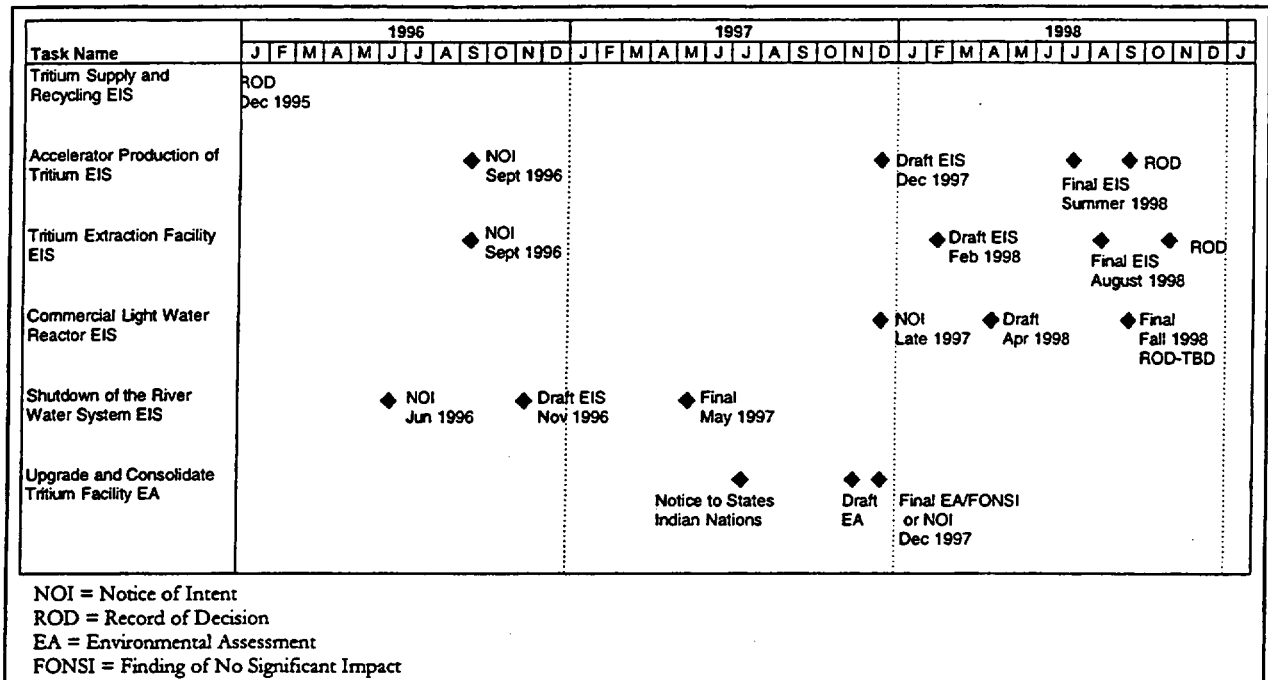

Figure 1-3. NEPA documentation for related DOE actions.

target material from the reactors to the SRS for tritium extraction.

**Tritium Extraction.** On September 5, 1996, DOE issued a "Notice of Intent to Prepare the Construction and Operation of a Tritium Extraction Facility at the Savannah River Site Environmental Impact Statement" (61 FR 4670). As currently planned, that EIS will evaluate the environmental impacts of facility construction and operation for two tritium extraction scenarios:

- The construction and operation of a new extraction facility that would provide the capability to process irradiated target rods from a commercial light water reactor, remove the impurity gases, and deliver weapons quality tritium to the existing Tritium Loading Facility (formerly known as the Replacement Tritium Facility). The extraction facility would be capable of extracting tritium from Lithium targets if DOE selects them for use in the accelerator.
- The upgrade and use of the existing Allied-General Nuclear Services facility located

approximately one mile east of the SRS in Barnwell, SC.

As with the APT and CLWR EISs, the upper-tier document for the tritium extraction EIS is the Tritium Supply and Recycling Programmatic EIS. The scheduled completion date for that EIS is August 1998.

**Upgrade and Consolidate SRS Tritium Facilities.** The Department is preparing an environmental assessment (EA) on the upgrade and consolidation of the SRS Tritium Facilities scheduled for completion in December 1997. In the Record of Decision for the Tritium Supply PEIS, DOE decided that the consolidated upgrade would result in closing one building (232-H) and transferring its functions to two other buildings in H-Area. The Department would upgrade four buildings in H-Area to meet environmental, health, and safety requirements and one other building to accept the transferred activities.

**Shutdown of the River Water System at the Savannah River Site.** DOE built the River Water System to pump large quantities of cooling water from the Savannah River to the SRS

nuclear reactors. Because the Department has shut the reactors down, no cooling water is currently required and the *SRS Strategic Plan* (DOE 1996b) has identified the system as potential surplus infrastructure. However, if the Department decides to build the APT, cooling water would be needed and may require parts of the existing cooling water system.

In May 1997, the Department issued its *Final Environmental Impact Statement: Shutdown of the River Water System at the Savannah River Site* (DOE 1997b). That document proposes to shut down the River Water System and place all or part of the system in a standby condition. Under the preferred "standby" alternative, DOE could place portions of the system in several different conditions; for example, surplus portions of the system could be shut down and deactivated. The deactivated portions would not be capable of restart. Other portions could be placed in a "layup" condition so they could support potential future missions such as an accelerator for the production of tritium. To attain the layup condition, DOE would shut the equipment down but would preserve it for future restart if necessary. As an alternative, DOE could place some portions of the system in a higher state of readiness than layup that would allow restart in a relatively short time.

## 1.6 Nonproliferation

Accelerator technology has been in use for more than 75 years. During this time they have been constructed in many different types and sizes, with power ranging from a few watts to approximately one megawatt. The possibility of producing special nuclear material (i.e., plutonium) using an accelerator was recognized several decades ago. However, using this option for large scale production was more costly than production in nuclear reactors. Therefore, special nuclear material production using an accelerator was not pursued by the nuclear weapons states, and basic science research became the primary use of accelerators. This research mission is promoted by the International Atomic Energy Agency through a program of informa-

tion sharing. The APT is the first known accelerator proposed for a mission to produce weapons materials in a sustained production operating mode.

Nuclear weapon's proliferation concerns arise when a technology is used to develop special nuclear materials. Using an accelerator to produce special nuclear materials in quantities which could be a proliferation concern requires a particle beam power of approximately 1 megawatt or greater. Research accelerators with beam powers in the 1 megawatt range have been viable for at least 20 years.

The APT brings together different pieces of accelerator technology which increase efficiency, and will be sufficiently large so production can meet the current and projected requirements of tritium. Since this is a change in the historic application of accelerator technology, the Department is reviewing how it controls the export of accelerator technology.

Currently, Section 57b. of the Atomic Energy Act requires that "persons" subject to U.S. jurisdiction who engage directly or indirectly in the production of special nuclear material outside of the United States must be authorized to do so by the Secretary of Energy. This requirement is implemented by DOE's regulations in 10 CFR Part 810, "Assistance to Foreign Atomic Energy Activities."

In implementing these requirements, the Department has determined they implicitly cover exports of accelerator technology to produce special nuclear materials. The Department is now in the process of determining whether to make this implicit coverage explicit. A proposed rulemaking amending the Part 810 regulations to this effect is under consideration.

## 1.7 Medical Isotope Production

With the high beam current and energy, the APT facilities could produce a reliable supply of medical radionuclides. The motivating force for the production of such radionuclides is the aging of existing U.S. production facilities and the

increasing reliance on foreign suppliers. A single foreign company supplies the medical nuclide most used in the United States (technetium-99m). A number of other nuclides used for treatment diagnosis, or research either are not available or are expensive due to short supply. The APT capability to produce radionuclides could meet present needs and adapt to future demands.

DOE could make medical isotopes in several areas of the accelerator. For example, it could extract some isotopes from the window cooling system, target, target cooling system, and the blanket region without modifying the current APT design. DOE could modify the design by installing devices to divert packets of protons at different energy levels to radionuclide-producing targets, or by modifying the blanket surrounding the target to insert targets for radionuclide production. If it decides to produce medical isotopes, DOE would build an isotope production facility or modify existing SRS facilities for that purpose.

The Department is considering the feasibility of using the accelerator, if it decides to build one, for medical isotope production. A preliminary feasibility study is under way. If that study results in a decision to proceed, DOE would have to perform additional conceptual design work. Because the design information will not be available for some time, this EIS does not discuss the use of the APT facilities to produce medical isotopes. DOE will complete a separate National Environmental Policy Act evaluation if it decides to proceed with a proposal to make medical isotopes in the APT facilities.

## 1.8 Stakeholder Participation

DOE conducted a public comment period to solicit input on the scope of this EIS. The public scoping period extended from September 5, 1996, to December 20, 1996. Public scoping

meetings were held on December 3 and December 5, 1996, in Savannah, Georgia, and Aiken, South Carolina, respectively. These meetings were attended by 63 members of the public. In addition, the Department received approximately 24 mail and phone comments on the scope of this EIS.

As a result of the scoping process for the APT and TEF EISs, the Department identified about 90 separate comments. The following is a brief summary of comments pertaining to APT issues or concerns being addressed in the EIS:

- Type of target material to be used -- The Department is evaluating both Helium-3 and Lithium-6 feedstock material.
- Benefits of using the existing river water system -- The potential use by the river water system to provide cooling water to the APT is an alternative being considered.
- Human health issues related to tritium production and the emissions from a new coal or gas-fired power plant that may be required -- The Department is considering the health impacts of its actions from both tritium production and a coal/gas-fired power plant.
- Impacts on surface water and groundwater -- Both surface water and groundwater impacts are being considered.

Several issues brought forth in scoping are not specifically being addressed in the APT EIS but are being considered by the Department in other forums, or were considered in the PEIS on Tritium Supply: most notably the potential impacts from commercial light water reactors, siting at the DOE complex sites, the use of other technologies, and cost and schedule.

Interested persons can review a summary of the comments received during the public scoping period and how they influenced the scope of the Draft EIS at the Department of Energy Public Reading Rooms, or can obtain a copy of this summary by phoning 1-800-881-7292, by contacting Andrew R. Grainger, U.S. Department of Energy, Savannah River Operations Office, Building 773-42A, Rm. 212, Aiken, South Carolina 29802; or by sending E-mail to nepa@SRS.gov.

## 1.9 Organization of the EIS

This EIS has seven chapters, supported by three appendixes, and discusses the important technology alternatives, including:

1. Type of accelerator technology
2. Type of feedstock material used to produce tritium
3. Water source and cooling technology
4. Type of radiofrequency amplifiers
5. Sources of electricity
6. APT site location on the SRS
7. Tritium extraction and modular or staged design option

Chapter 2 describes the Proposed Action and Alternatives for the accelerator. Chapter 3 discusses the SRS and the Central Savannah River Area in terms of the environment that the alternatives could impact and environmental features that could influence the construction and operation of the accelerator. Chapter 4 presents the estimated impacts for the construction and operation of the APT. Chapter 5 discusses cumulative impacts. Chapter 6 presents resource commitments. Chapter 7 discusses applicable laws, regulations, and permit requirements.

This EIS also contains 3 appendixes. Appendix A contains a description of facilities and processes. Appendix B provides information on accident scenarios. Appendix C is a list of plants and animals mentioned in this EIS. To aid readability, common names are used in the body of the text for plant and animal species. Scientific names are included in Appendix C for additional clarification. Throughout the text, the units of measurement utilized are those commonly employed for a particular parameter. A conversion table is included on page xix.



## References

- DOE (U.S. Department of Energy), 1991, *Nuclear Weapons Complex Reconfiguration Study*, Washington, D.C.
- DOE (U.S. Department of Energy), 1995, *Final Programmatic Environmental Impact Statement for Tritium Supply and Recycling*, DOE/EIS-0161, Office of Reconfiguration, Washington, D.C.
- DOE (U.S. Department of Energy), 1996a, *Final Programmatic Environmental Impact Statement for Stockpile Stewardship and Management*, DOE/EIS-0236, Washington, D.C.
- DOE (U.S. Department of Energy), 1996b, *Savannah River Site Strategic Plan*, Savannah River Operations Office, Aiken, South Carolina.
- DOE (U.S. Department of Energy), 1997a, *Section II, Chapter 11, Tritium Supply: Critical Sciences, Technologies and Capabilities for Stockpile Stewardship and Management*, Washington, D.C.
- DOE (U.S. Department of Energy), 1997b, *Final Environmental Impact Statement: Shutdown of the River Water System at the Savannah River Site*, DOE/EIS-268, Savannah River Operations Office, Aiken, South Carolina.

# Chapter 2

Proposed Action and Alternatives

---

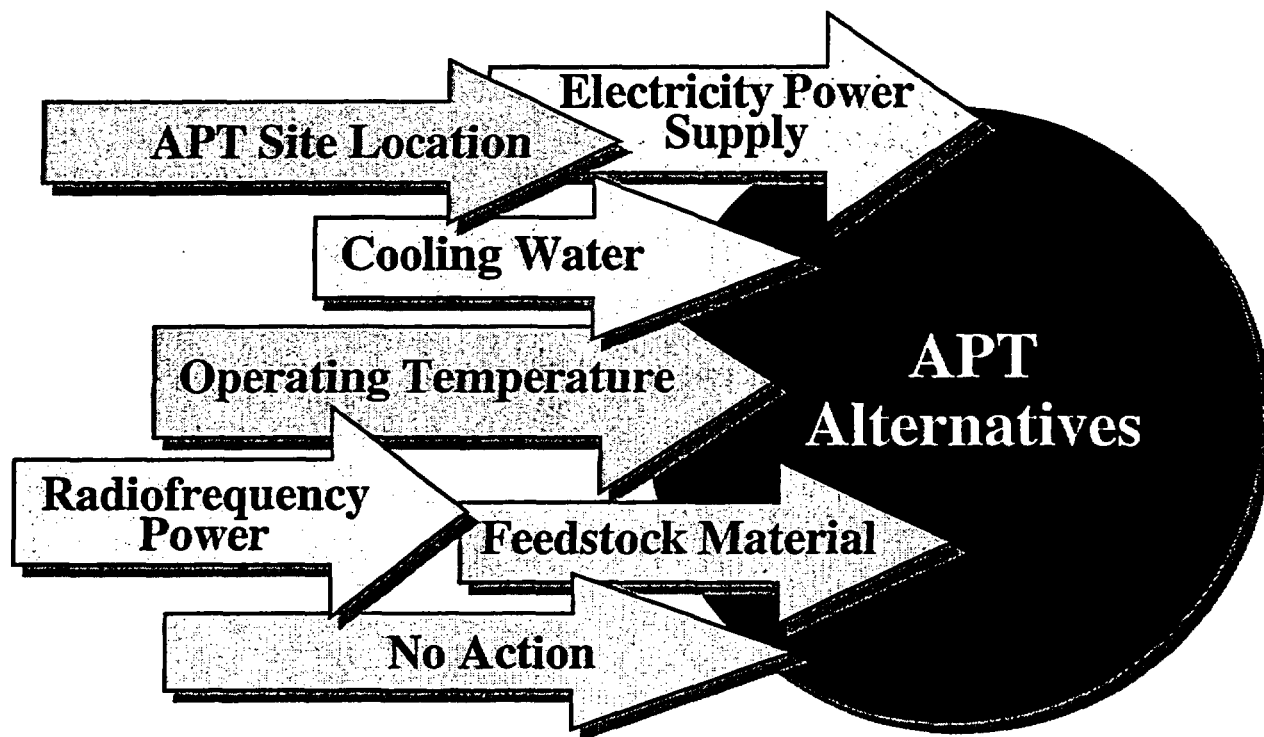

DOE is considering alternative design features for an accelerator at the Savannah River Site: how the accelerator would be supplied electricity; which of two sites on the SRS would be used; how the accelerator would be cooled; the operating temperature to be used; which feedstock material (Helium-3 or Lithium-6) to be used for tritium production; and the types of radiofrequency amplifiers. Additionally, two design variations are under consideration: the construction of a modular accelerator that could be expanded if tritium stockpile requirements increase, and a tritium extraction facility within the accelerator that could extract tritium from Lithium-6 feedstock material.

## CHAPTER 2. PROPOSED ACTION AND ALTERNATIVES

Chapter 1 describes the dual-track strategy the Department of Energy developed to ensure the production of tritium for the Nation's defense needs in the 21st Century. Part of the strategy calls for DOE to evaluate the construction and operation of the APT to produce tritium and to propose different design features for the APT. This chapter describes alternative design features and support systems. It discusses operating temperatures, target configurations, radiofrequency power supplies, cooling water scenarios, electricity options, and facility location. It also compares potential environmental impacts associated with each design feature. Additionally, the chapter considers design variations which could enhance DOE's ability to meet changing requirements for tritium.

The regulations of the Council on Environmental Quality (CEQ; 40 CFR Parts 1500-1508) direct Federal agencies to use the process established by the National Environmental Policy Act (NEPA) to identify and assess reasonable alternatives, including a "No Action" alternative, to proposed actions that could have effects on the quality of the human environment.

### 2.1 The Proposed Action and No Action Alternative

The Nation's need for new production of tritium, in terms of both the quantity required and the date by which it must be available, has changed substantially in the past several years and is likely to continue to change. DOE's tritium production program must, therefore, be sufficiently flexible to respond to a variety of potential production requirements. This requirement for programmatic flexibility is driven by the range of possible outcomes of nuclear weapons treaty negotiation and ratification activities, and the annual Federal budget and approval process (WSRC 1997).

**The Proposed Action.** In responding to this need, the Department is developing a baseline APT design that would be capable of producing 3 kilograms per year of tritium by 2007. The Proposed Action is to design, build, and operate a linear accelerator at the Savannah River Site with specific design features as discussed below. Development work is ongoing, however, on two design variations that could enhance the flexibility and cost efficiency of supplying the nation's tritium need. The first would utilize a modular or staged approach whereby an accel-

erator initially designed to produce 1.5 kilograms per year of tritium could be expanded in stages to meet higher production levels; secondly, the proposed Tritium Extraction Facility, required to separate tritium from targets irradiated in commercial light water reactors, could be incorporated into the APT design

Following the discussion of the proposed APT baseline configuration and alternatives (see Section 2.3), the two design variations are discussed in Section 2.5 of this chapter. This section also compares how tritium production levels could be increased in the proposed baseline configuration and in the modular design. Section 2.4 describes other actions that could occur regardless of the design alternatives selected.

Based on its research and development activities, DOE proposes the following Preferred alternative design and support features for the baseline APT:

- Klystron radiofrequency power tubes
- Superconducting operation of accelerator structures
- Helium-3 feedstock material
- Mechanical-draft cooling towers with river water makeup
- Construction of the APT on a 250-acre site 3 miles northeast of the Tritium Loading Facility

- Purchase of electricity from existing capacity and market transactions

In addition, DOE has identified the following alternative design features and support systems:

- Inductive output radiofrequency power tubes
- Room-temperature operation of some electrical components
- Lithium-6 feedstock material
- Once-through cooling using river water; mechanical-draft cooling towers with groundwater makeup; K-Area cooling tower with river water makeup
- Construction of the APT on a site 2 miles northwest of the Tritium Loading Facility
- Construction of a new generating plant for electricity

Section 2.3 describes the proposed and alternative design features and support systems. In addition, if DOE constructed and operated the APT, it would conduct activities at specific locations on the Site that would not depend on selected design features or support systems. Section 2.4 describes activities that are independent of the alternatives (except No Action). Appendix A provides more detailed facility descriptions.

**No Action Alternative.** In compliance with CEQ regulations (40 CFR Part 1502), this environmental impact statement (EIS) assesses a No Action alternative, under which DOE would defer indefinitely any decision related to the final selection of APT design features and would place the research and development information completed at the time it made its decision in an archive. As a result of this alternative, DOE would have to meet its tritium production requirements through other methods, or it would not be able to support the long-term defense policies of the United States.

Under the No Action alternative, other SRS operations related to tritium, specifically recycling and loading activities, would continue. Other actions that DOE determined in its Record of Decision for the *Final Programmatic Environmental Impact Statement for Tritium Supply and Recycling* (DOE 1995) -- the potential construction and operation of a new Tritium Extraction Facility and the potential modernization and consolidation of existing SRS tritium facilities -- would proceed as planned.

## 2.2 APT Overview

The design of an accelerator facility depends heavily on its purpose. The APT would be about 4,000 feet long and could provide about 1.5-3.0 kilograms of tritium a year. For the analyses in this EIS, DOE assumed that the APT would produce 3 kilograms of tritium a year. Section 2.5.1 describes how DOE could increase tritium production levels from a goal quantity of 1.5 kilograms of tritium per year.

The many individual systems and components of the APT are used to perform one of two functions: production of tritium or support for the production. This section discusses the overall approach to producing and recovering tritium in the APT. Support facilities are described in more detail in Section 2.4 and Section A.5.

Figure 2-1 shows the major steps of the process used at the APT to produce and recover tritium. As shown in the figure, the first step is to accelerate protons to high energies. Figure 2-2 shows the relationship of the major APT structures. The second step in producing tritium involves using the protons to produce neutrons through spallation (see Figure 2-3) and the production of tritium by allowing feedstock material to absorb the neutrons. The final step is to recover the tritium from the feedstock material and purify it for eventual use.

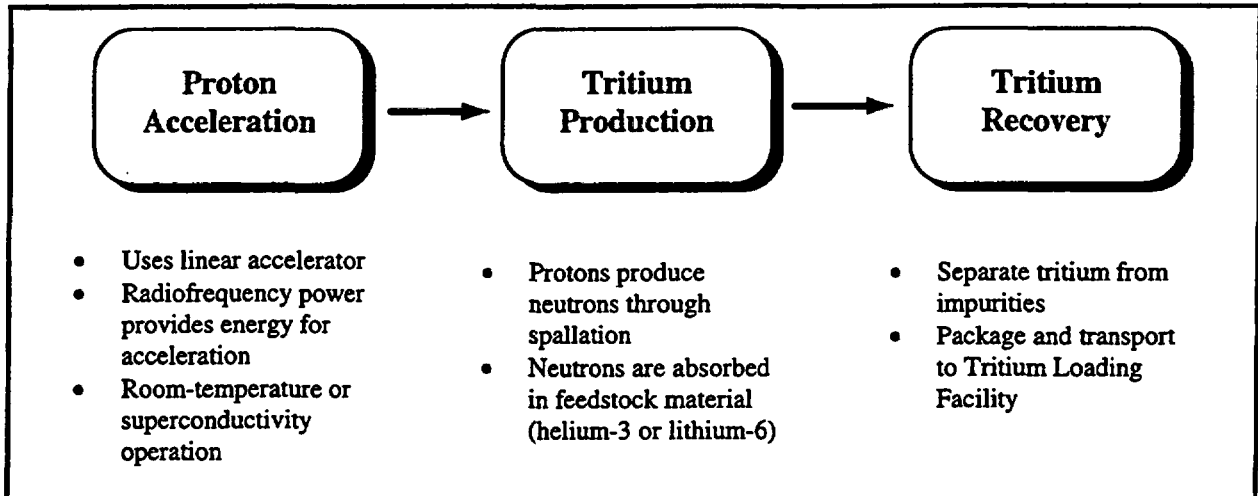

Figure 2-1. Major steps in the APT process.

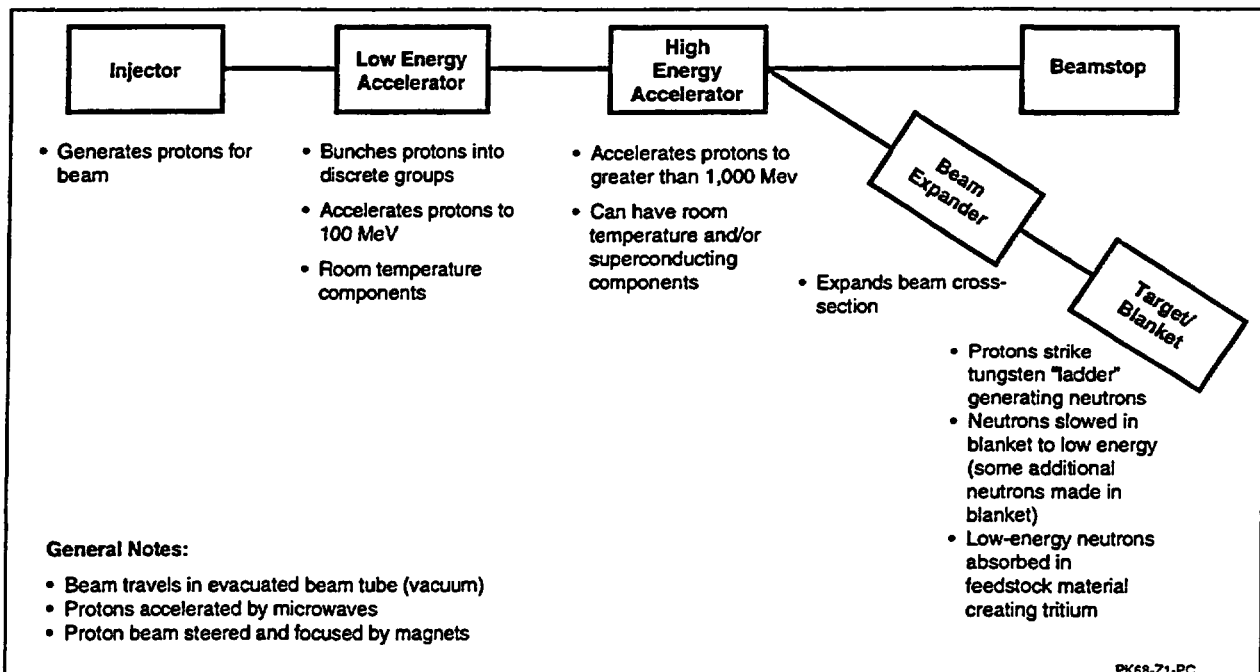
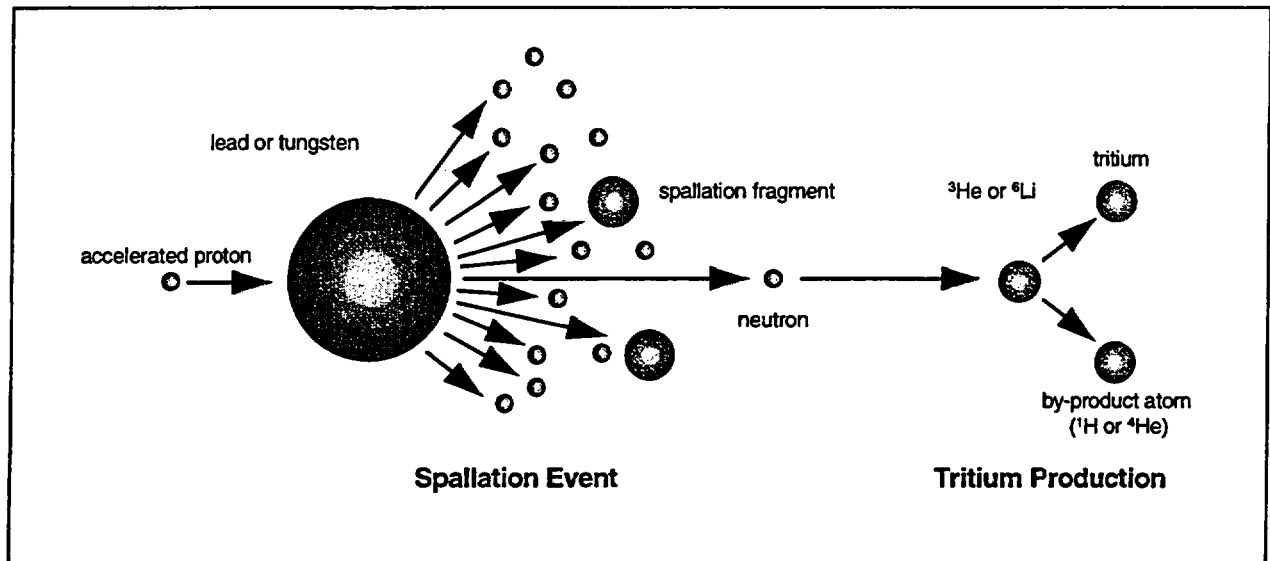

Figure 2-2. Accelerator schematic.



**Figure 2-3.** A pictorial representation of tritium production using neutrons generated by spallation. The proton strikes the target atom, which breaks into multiple fragments with the emission of neutrons. The neutrons then strike atoms ( $^3\text{He}$  or  $^6\text{Li}$ ), producing tritium and a by-product atom ( $^1\text{H}$  or  $^4\text{He}$ ).

### Proton Acceleration

The APT project will use a linear accelerator to accelerate a beam of protons to energies greater than 1,000 MeV. The specific final energy of the beam is dependent upon the selection of design alternatives.

*MeV* is a unit of energy. In this EIS, it describes a particle's kinetic energy, which is an indicator of the particle's speed. A proton with 1,700 MeV of kinetic energy would travel at 94 percent of the speed of light.

The first part of the APT accelerator is an injector which serves as the source of protons. To provide these protons, hydrogen gas at low pressure is piped into the injector assembly, and microwaves heat the gas to a plasma state in which the hydrogen atoms lose their electrons leaving behind the positively charged protons which are the nuclei of hydrogen atoms. An electric voltage is applied to remove the protons from the injector and to direct them to the next stage of the accelerator.

The protons extracted from the injector are focused using electromagnetic fields so that the protons are formed into and maintained as a

beam to be transported down the length of the accelerator. Acceleration of the protons is accomplished using radiofrequency waves which are generated in radiofrequency power tubes, captured in conducting metal conduits (waveguides), and guided to strategic points along the accelerator to specially designed cavities. As the protons move down the length of the accelerator, they are exposed to the radiofrequency waves at optimum times for acceleration.

Although it is convenient to think of the accelerator as a single unit, it actually consists of several different accelerators with different geometries in series. The geometries are selected to provide maximum efficiency in radiofrequency power to beam power at each energy level. All these designs are highly modular and provide easy operation and maintenance because the operators and maintainers can adjust and service the system in short sections.

### Tritium Production

Once the protons reach the desired energy, they are directed toward the target/blanket assembly. As the proton beam approaches the entrance to the target/blanket, however, it will have power

in excess of 100 megawatts, much of which would be converted to heat in the target/blanket assembly. To prevent a highly localized heating of the target/blanket, a beam expander will be used. This device will increase the cross-sectional area of the beam using magnets and create a more uniform distribution of protons to generate the maximum useful neutron flux and to allow the engineered heat removal systems for the target/blanket to better dissipate the heat.

After passing through the beam expander, the proton beam would be directed to the tungsten target (heavy water cooled) and blanket modules. The high energy of the protons as they strike the tungsten target causes the nuclei of the atoms in the target to break into fragments, ejecting neutrons and secondary particles in all directions; this process is called spallation. The number of neutrons produced by high-energy spallation processes can be considerable. For example, in an ideal thick tungsten or lead target, approximately 31 neutrons are produced per incident 1,000 MeV proton, and approximately 58 at 1,700 MeV.

The target is surrounded by blanket modules which contain lead, feedstock (Helium-3 or Lithium-6), and a light water moderator coolant. The neutrons are moderated (slowed down) by D<sub>2</sub>O (heavy water) and H<sub>2</sub>O to an energy low enough to be efficiently absorbed by the tritium-production feedstock. Thus, tritium is produced through a series of nuclear reactions. First, the protons are used to produce neutrons through spallation; then the neutrons are absorbed in a feedstock material to form tritium.

### Tritium Recovery

Once the tritium is produced in the feedstock material, it must be recovered and purified. The exact method for recovering the material depends on the type of feedstock material being used (as discussed in Section 2.3). For the case of the Helium-3 feedstock, recovering the tritium is a matter of separating the tritium from the other isotopes of hydrogen and Helium in a gaseous mixture. For the case of Lithium-6

feedstock, recovering the tritium involves extracting the tritium from a solid aluminum matrix through melting of the rods and then separating it from other isotopes of hydrogen and Helium. In both cases, the tritium recovered from the feedstock material would be transported to the Tritium Loading Facility at the Savannah River Site.

## 2.3 APT Design Features and Technology Alternatives

### 2.3.1 RADIOFREQUENCY POWER ALTERNATIVES

As discussed in Section 2.2, the APT would accelerate protons by the use of radiofrequency (RF) waves. Specially designed vacuum electron tubes would convert electric power to RF waves in a separate building, and waveguides (hollow metal conduits) would transmit them to cells along the beam path. Because radiofrequency waves have an electric and magnetic field component, their presence would affect the charged proton beam. The accelerator design would enable the proton beam to be exposed to the radiofrequency waves at the proper orientation to cause acceleration.

Because the protons get their energy from the radiofrequency waves, the electron tubes that generate the waves are the largest electrical load in the APT.

DOE has identified two alternatives -- klystrons and inductive output tubes -- that could supply radiofrequency power for the accelerator. Regardless of the type of tube selected, approximately 240 would be needed to provide enough power to accelerate the protons. Several tubes are expected to fail each month. If DOE decides to build the APT, it would construct a facility at the APT site to rebuild damaged tubes and provide replacement tubes. This would permit the rapid replacement of damaged tubes and increase the operational availability of the accelerator. The following sections describe the two potential radiofrequency power alternatives -- klystrons and inductive output tubes.



**Klystron.** The klystron is an established technology that radar installations and television broadcast stations have used for years to generate broadcast signals. The klystron is an electron tube that uses a beam of electrons to amplify a microwave signal. In principle, the electron beam is directed to a relatively weak microwave field inside the tube. The presence of the electromagnetic fields in the microwave signal causes modulation of the electron beam into "packets" of electrons. The beam then passes through a cavity tuned to the same frequency as the input signal, and the electrons induce a microwave signal that is an amplified version of the original signal.

**Inductive Output Tube.** The inductive output tube was developed in the 1930s and has been used extensively since the 1970s in television transmitters. As with the klystron, its purpose is to amplify microwaves, but it does so in a different way. The inductive output tube also extracts large amounts of RF power from a high current electron beam that is modulated into electron "packets." However, in contrast to the klystron, the modulation is produced directly in the electron beam by using the input signal to control emission of electrons. Inductive output tubes are typically smaller than radiofrequency power tubes and have greater efficiency, thereby providing the same microwave amplification with less input power and smaller energy losses.

### 2.3.2 OPERATING TEMPERATURE ALTERNATIVES

Accelerator structures would be affected by the temperatures at which they operate, depending on the type and intended use. Electrical resistance usually increases as temperature increases, which causes more heat generation in the component and results in a greater use of electricity. The converse is also true: that is, electrical resistance usually decreases as temperature decreases, causing less heat generation and resulting in less electricity use. If the temperature of some materials (e.g., niobium) is reduced to a very low value near absolute zero (-456°F),

their electrical resistance becomes essentially zero, and the component will use much less electricity. This phenomenon is referred to as superconductivity.

DOE has identified two operating temperature alternatives for the design of the accelerator:

- Operation of accelerator structures at essentially room temperature
- Operation of most of the accelerator structures at superconducting temperatures and the remaining components at room temperature

**Room Temperature Operation.** Under this alternative, DOE would provide necessary cooling to ensure the maintenance of electric components of the accelerator at approximately room temperature. The Department would use either air or water cooling of the components to prevent overheating.

**Superconducting Operation.** Under this alternative, DOE would divide the linear accelerator into two subsystems, the low-energy and high-energy accelerator systems. The low-energy system would operate at room temperature; the cells of the high-energy system, responsible for accelerating protons from about 200 to 1,700 MeV, would be superconducting. This alternative would supply liquid Helium to accelerating cavities of niobium and maintain the cavities at approximately -456°F, which would ensure superconductivity. Other electronic components would operate at room temperature, as described above.

If DOE implements this alternative, it would build a refrigerator and liquid Helium distribution system to serve the accelerator. This facility, which the Department would build on the same site as the accelerator, would produce liquid Helium by compressing Helium gas stored in tanks. DOE would maintain enough liquid Helium to cool the accelerator components in the event of a power loss.

The temperature of the niobium cavities in the accelerator would be about  $-456^{\circ}\text{F}$ , which is about  $4^{\circ}\text{F}$  above absolute zero, the coldest possible temperature that can exist.

### 2.3.3 FEEDSTOCK MATERIAL ALTERNATIVES

The accelerator would produce protons with an energy greater than 1,000 MeV. To produce tritium, the proton beam would be expanded from its relatively small size (a diameter of approximately 0.079 inch) in the accelerator to a rectangular beam that would be 6.3 inches wide and 63 inches tall. The protons would strike a target/blanket assembly of tungsten and lead. The high energy of the protons as they impacted the tungsten atoms would cause spallation events, as described in Section 2.2, with the emission of neutrons. The lead in the blanket modules would further increase the number of neutrons through additional reactions. The neutrons would strike the tritium feedstock material, the atoms of which would undergo a nuclear reaction that absorbed neutrons, resulting in the production of a tritium atom and another byproduct atom (Figure 2-3).

DOE has identified two possible feedstock materials that would produce tritium through the absorption of neutrons produced by spallation events. In addition, the Department has concluded that it could use the same type of target/blanket (lead and tungsten) as the neutron source regardless of the feedstock material used. The following sections describe the two potential feedstock materials -- gaseous Helium-3 and solid Lithium-6.

**Helium-3 Feedstock Material.** Helium-3 is a nonradioactive gas that exists naturally in small quantities in the atmosphere. It is also produced through the radioactive decay of tritium. It has been used for many years to make radiation detectors for neutrons, and its chemical and physical properties are well understood. Helium-3 is available for use at the SRS from past operations of the Tritium Loading Facility and from the DOE Mound Facility in Miamis-

burg, Ohio. Thus, DOE could ensure a supply of Helium-3 for immediate use in the APT if it selected this alternative.

Under this alternative, the Helium-3 would be contained in aluminum tubes within the target/blanket assembly. Helium reacting with a neutron would be converted to tritium producing a mixture of tritium and other atoms as shown in Figure 2-3. The Helium-3 and tritium mixture would be continuously transported via piping to the Tritium Separation Facility (TSF) in close proximity to the Target/Blanket Building.

A series of devices would be used to remove impurities and spallation products from the Helium-3 stream before it is sent to the TSF building. Extraction of the hydrogen isotopes from Helium-3 would be performed with palladium-silver permeators, which allow hydrogen isotopes, but not Helium-3, to permeate. Helium-3 would be recirculated back to blanket modules. Then, tritium would be separated from the other hydrogen isotopes by using cryogenic distillation (separate from the cryogenic system that would be used in the superconductive alternative). The purified tritium product would be stored in the TSF and loaded into shipping containers for transportation to SRS tritium facilities.

The Helium-3 blanket system would permit the continuous extraction of tritium as it was produced, thereby limiting the inventory of tritium in the blanket area at any time.

Additional information regarding TSF and its operation is provided in Section A.4 of Appendix A. A brief description of TEF functions is provided in Section A.6.2 of Appendix A.

**Lithium-6 Feedstock Material.** This alternative would incorporate Lithium-6 into a solid aluminum matrix and form it into rods that DOE would place in the blanket area of the accelerator. While not identical to the rods DOE used when it operated the SRS tritium production reactors, the rods would produce tritium in a similar fashion.

For this alternative, the Lithium-6 rods would be in the form of aluminum-Lithium alloy rods clad in aluminum. The rods would be placed in the target/blanket assembly to be irradiated by neutrons. After irradiation, DOE would shut down the accelerator and replace the irradiated rods with new unirradiated rods. After the rods cool enough to handle safely, DOE would transport them to the proposed Tritium Extraction Facility (61 FR 46790), which would remove tritium from Lithium rods using processes similar to those DOE used in SRS Tritium Facilities. The Lithium rods would be cut into pieces, placed in large crucibles, and heated in a furnace to melt the aluminum and drive the tritium from the matrix. The TEF would collect and purify the gaseous tritium and send it to the Tritium Loading Facility. See also Section 2.5.3 regarding the potential of combining the TEF with the APT TSF.

Because the Lithium must be incorporated in a solid rod matrix, the Lithium feedstock alternative would require batch production of tritium instead of continuous extraction. The accelerator would operate during the irradiation, and would be in shutdown mode during the removal of the irradiated rods and the insertion of the new rods into the target/blanket assembly.

### 2.3.4 COOLING WATER SYSTEM ALTERNATIVES

The equipment and activities in the APT would generate heat that would have to be removed to prevent overheating of components. Air cooling would be sufficient to keep some parts of the APT cool. Other areas would be subject to high localized temperatures (e.g., the target and blanket regions due to the impingement of the proton beam on the target and the heat generated by radioactive decay in the target/blanket). Cooling water would be required to keep the target/blanket components, radiation shielding, beamstops, and other APT components from overheating.

Although these components would not necessarily be connected to the same cooling system, DOE proposes to use a primary coolant loop

isolated from the environment through heat exchangers to cool each component. The primary coolant loop would be the first system in contact with a component that required cooling, and heat would transfer from the component to the primary coolant loop.

*A heat exchanger allows heat to pass from one system to another without mixing the contents of the systems. For example, a car radiator is an air-cooled heat exchanger because it permits heat from the primary coolant (the antifreeze/water mixture) to dissipate by passing air over the cooling fins of the radiator.*

For components with the potential for radioactive contamination, a secondary coolant loop would cool the primary loop through water-cooled heat exchangers and would be isolated from the environment in a manner similar to the primary coolant loop. For these systems, a tertiary coolant system would cool the secondary loop through water-cooled heat exchangers, and would be the principal point of heat discharge to the environment. The tertiary system would be a "clean" system; that is, it likely would not release more than extremely small amounts of contamination to the environment. For components with little or no potential for radioactive contamination, the final cooling water system would be linked to the primary coolant loop.

DOE has considered both surface and ground-water sources for the cooling water system. If DOE selects surface water, it would be drawn from the Savannah River using portions of the existing River Water System (WSRC 1996a) upgraded as necessary to support APT operation. If DOE selects groundwater, new wells would be drilled near the APT site.

DOE has identified four designs for the tertiary coolant system to provide the necessary cooling capacity for the accelerator:

- Mechanical-draft cooling towers with river water makeup

- Mechanical-draft cooling towers with groundwater makeup
- Once-through cooling using river water
- K-Area natural-draft cooling tower with river water makeup

Figure 2-4 is a schematic diagram of the cooling water system alternatives this EIS analyzes; it shows how DOE could implement these alternatives. The figure is drawn assuming that the component to be cooled has the potential for radiation contamination and, thus, has a primary and secondary loop. For nonradioactive systems, the illustrated secondary coolant system would not be present and the cooling water system would be linked to the primary coolant loop.

In assessing the cooling water system alternatives, DOE considered existing structures and systems to the extent possible. Figure 2-5 shows these systems and structures, notable among which are the River Water System, which has lines throughout the SRS; Par Pond, which could receive cooling water or blowdown via the "pre-cooler" ponds (Ponds 2, 5 and C); K-Area, which contains a natural-draft cooling tower that discharges to Indian Grave Branch and Pen Branch; and the preferred and alternate accelerator sites. Information related to the cooling water alternatives described in the following sections was derived from the APT Cooling Water Supply Makeup Trade Study (WSRC 1996a).

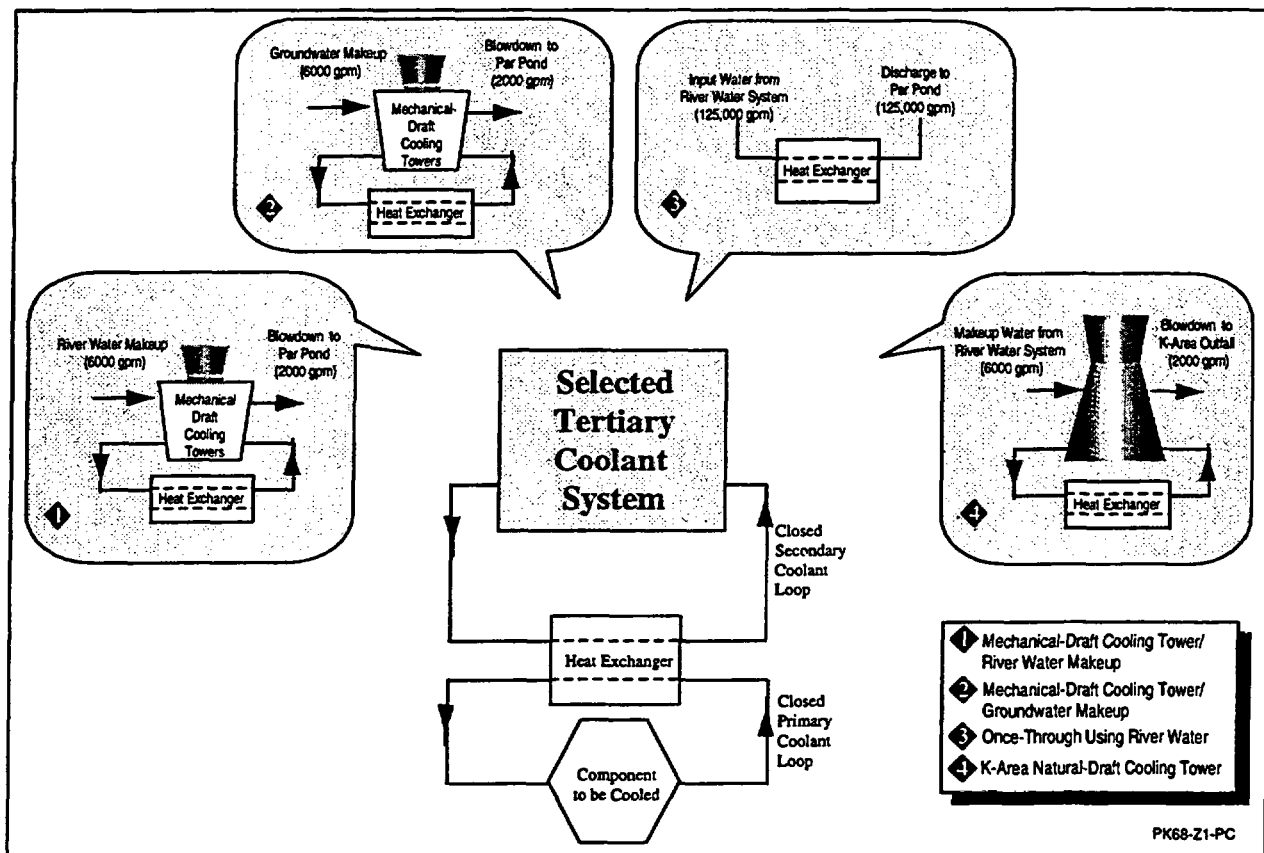

Figure 2-4. Schematic diagram of the cooling water system alternatives for APT components with approximate water flows. This drawing assumes that the component to be cooled has the potential for radioactive contamination. For nonradioactive systems, the illustrated secondary coolant system would not be present and the final cooling water system would be linked to the primary coolant loop.

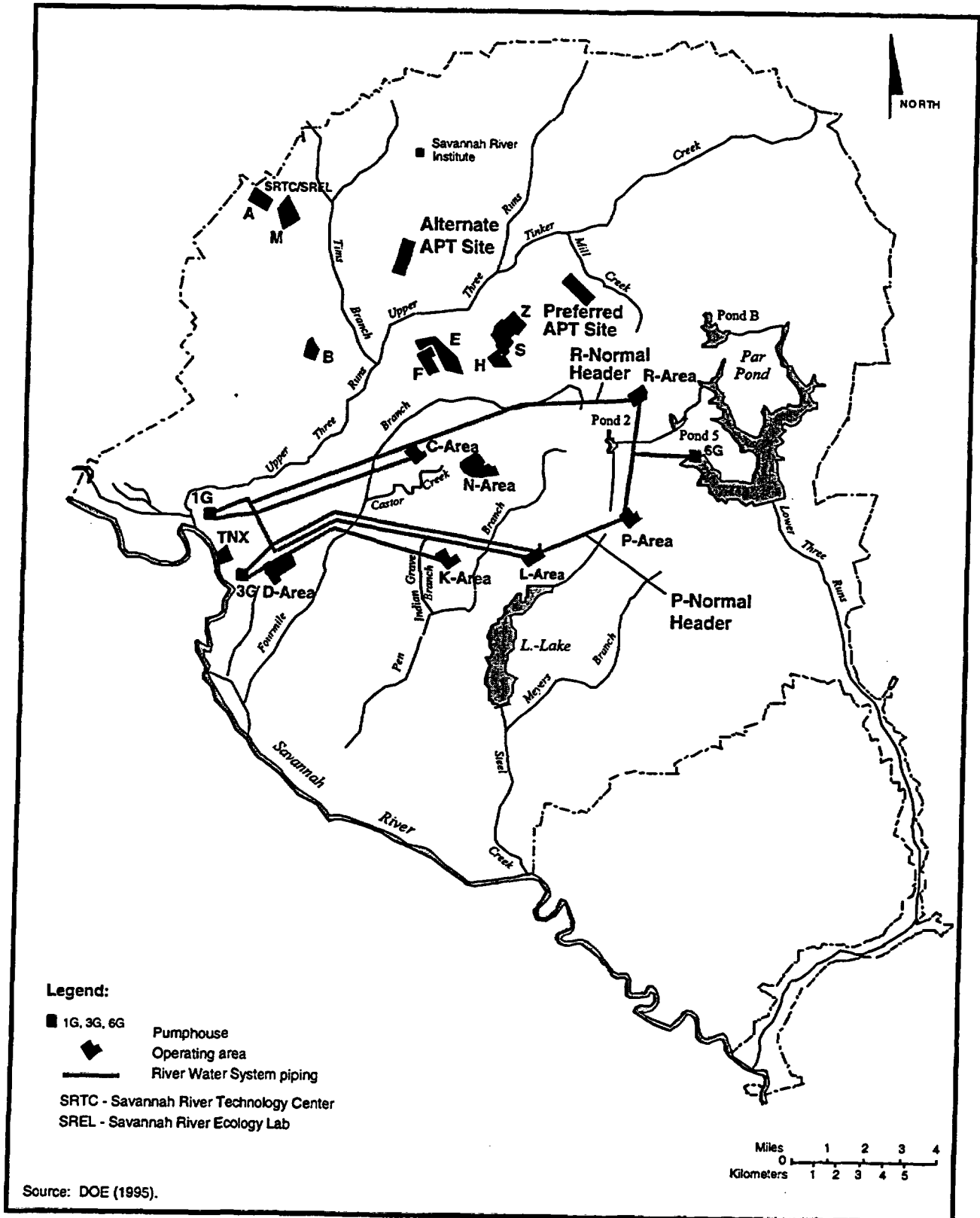

Figure 2-5. Map of the SRS showing existing features that could be used to provide cooling water for the accelerator.

PK68-Z1-PC

**Mechanical-Draft Cooling Towers with River Water Makeup.** A mechanical-draft cooling tower uses forced air to cool water that circulates through it. In principle, cool water from the tower circulates through a piece of equipment that requires cooling. The water heats as it cools the equipment, and circulates back to the cooling tower. The heated water flows into the cooling tower and is dispersed in the tower as small droplets. Large fans at the top of the tower draw in ambient air, which evaporates some of the heated water and cools the rest. Finally, the cooled water collects in a basin in the bottom of the tower and recirculates back to cool the equipment. Figure 2-6 is a photograph of a typical mechanical-draft cooling tower.

This alternative would involve the construction of mechanical-draft cooling towers with recirculating cooling water (i.e., most of the water that flows through the cooling tower would circulate continuously to provide cooling). Water from the towers (at a flow rate of approximately 125,000 gallons per minute) would pass through a heat exchanger that would transfer heat from the secondary coolant loop of the accelerator. The heated water (as illustrated in Figure 2-4)

would pass from the heat exchanger to the cooling towers, where ambient air would cool the water, resulting in a release of heat to the atmosphere. The cooled water would pass to the heat exchanger again to receive heat from the secondary coolant loop.

Over time, the water in the cooling tower system would require replenishment because the water:

- Evaporates from the system
- Leaves the system as water droplets to the atmosphere (drift)
- Leaks from the system
- Is discharged intentionally from the system (as blowdown) because of relatively high concentrations of salts

Makeup water (i.e., water to replenish these losses) for the cooling tower would come from the SRS River Water System (see Figure 2-5) after some modification. DOE originally used this system to provide cooling for the onsite re-

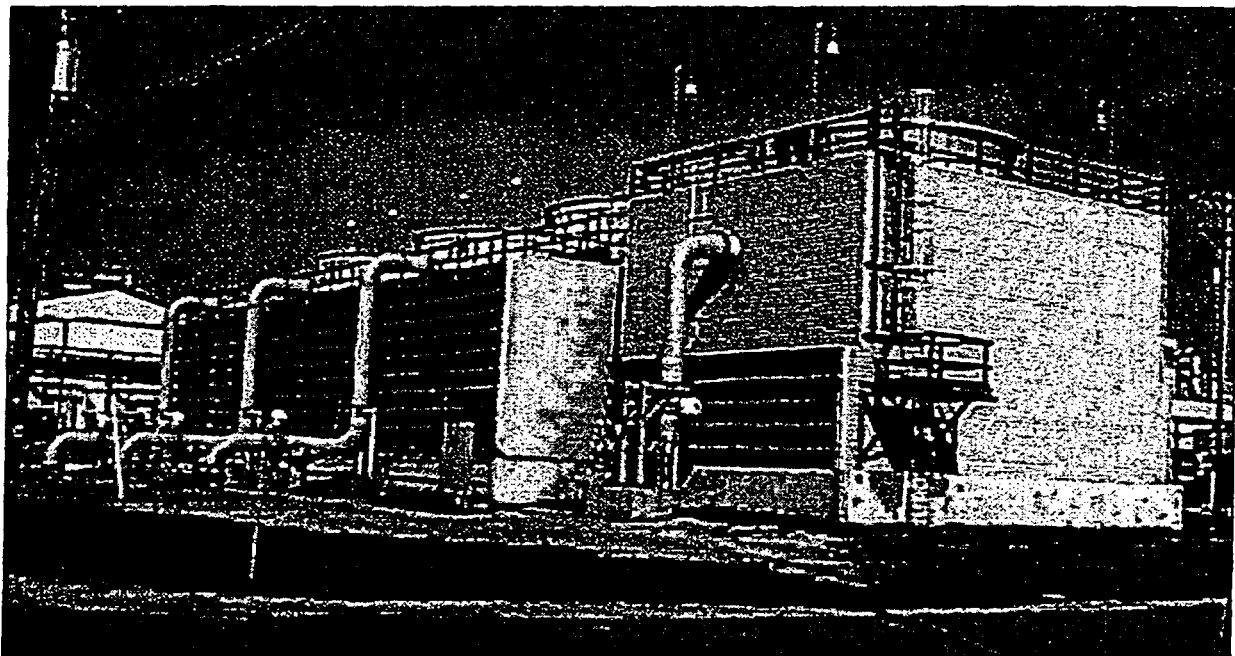

Figure 2-6. An example of mechanical-draft cooling towers at the SRS. This cooling tower is located in A-Area and has four exhaust areas on top.

actors; the system now has a capacity of about 150,000 gallons per minute. DOE estimates that it would need about 6,000 gallons per minute to keep a constant level of coolant in the cooling tower system. DOE would upgrade the River Water System to supply water to the APT site. This would include installing two new pumps in a pumphouse to handle required flow rates, which would be lower than those historically used in the River Water System; using the existing "R-Normal" river water header; and adding pipe to move the water to the APT site and to move the continuous blowdown to the Par Pond system.

**Mechanical-Draft Cooling Towers with Groundwater Makeup.** This alternative would be similar to that described above, except the makeup water would come from groundwater wells drilled near the accelerator site. Because this alternative would use recirculating water in the cooling tower loop, about 6,000 gallons per minute, would be required to maintain a constant level of coolant in the system. However, the projected capacity of a single production well is only about 500 gallons per minute. To supply 6,000 gallons per minute and provide backup capacity, DOE would drill 18 wells and route the pumped water to a central well field tank for transfer to the APT cooling towers.

DOE would connect all 18 wells to the central well field tank by piping. Additional pipe would connect the tank to the cooling towers. As described above, the blowdown from this cooling alternative would flow to the Par Pond system (see Figure 2-5), which would require additional pipe.

**Once-Through Cooling Using River Water.** Under this alternative, the APT would not use a cooling tower. Instead, DOE would pipe large volumes of water from the Savannah River, using the River Water System (see Figure 2-5) with modification (i.e., replacement of pumps, addition of pipe) to move the water from the R-Normal header to the APT site. The water would pass through heat exchangers to remove heat from the secondary coolant loop (as illus-

trated in Figure 2-4) and would discharge directly to the Par Pond system.

The River Water System now has a capacity of about 150,000 gallons per minute. DOE estimates that once-through cooling would use no more than 125,000 gallons per minute. DOE would upgrade the system by adding pipe to transport river water to the APT site. In addition, DOE would install four pumps and additional pipe to transport the heated water from the APT to Par Pond.

**K-Area Cooling Tower with River Water Makeup.** Under this alternative, the K-Area cooling tower (see Figure 2-7) would provide cooling for the APT. DOE built this natural-draft cooling tower to mitigate thermal impacts from K-Reactor operation. However, the tower was never used because of the decision to permanently shutdown K-Reactor. A natural-draft cooling tower operates on the principle of water evaporation, just as a mechanical-draft tower. However, a natural-draft tower is designed to use natural air currents, whereas a mechanical-draft cooling tower uses fans to generate air currents. As a consequence, natural-draft cooling towers are typically taller than mechanical-draft towers to create more air flow through the tower structure.

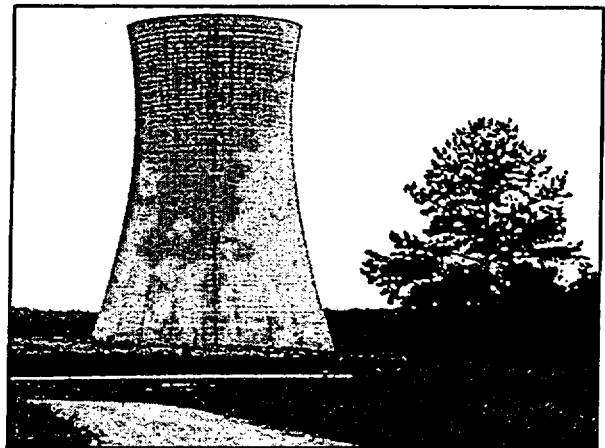

Figure 2-7. Photograph of the K-Area natural-draft cooling tower that was constructed in the early 1990s but never operated.

DOE would use the River Water System to provide makeup water for the cooling tower and to move the cooling water between the tower and the APT. This would minimize the need for new piping. As shown in Figure 2-5, K-Area is some distance from the sites proposed for the accelerator. Several miles of pipe would supply the 125,000-gallon-per-minute flow rate from K-Area to the APT using pumps at the cooling tower. Much of this would use existing river water system piping, but some additional pipe would be required to tie into the APT site. The return leg of the cooling loop would require additional pumps and pipe that would connect to the R-Normal header of the River Water System. DOE would modify the river water lines in R- and P-Areas to enable flow from the R-Normal header to a portion of the P-Normal header. Finally, 300 feet of pipe would connect the P-Normal header to the K-Area Cooling Tower.

### 2.3.5 APT SITE LOCATION ALTERNATIVES

The Department conducted a site screening process (described below) to select potentially suitable APT sites. Using a multiple phase process, site areas exhibiting a set of suitable site features with minimal conflicts with onsite resources and operational areas were identified. A complete set of criteria used can be found in the *Site Selection for the Accelerator for Production of Tritium at the Savannah River Site* (Wike et al. 1996).

The Department selected two sites for further analysis, as shown in Figure 2-8. In this EIS, the Department has chosen to designate these sites as the preferred site and the alternate site. A brief description of each site is included below; Chapter 3 describes the characteristics of both sites in detail.

**Preferred Site.** The preferred site is located approximately 3 miles northeast of the Tritium Loading Facility and is northeast of the intersection of Roads F and E. The site is bordered on the southwest by a 115 kV transmission line, a buried control and relay cable, and Monroe Owens Road, a natural surface secondary road.

The site is at an elevation of 300-330 feet above mean sea level and has several streams (Mill Creek, McQueen Branch, and Tinker Creek) nearby. The preferred site is approximately 6.5 miles from the SRS boundary.

**Alternate Site.** The alternate site is located approximately 2 miles northwest of the Tritium Loading Facility and is southeast of the intersection of Roads F and 2. The alternate site is crossed by a 115-kV power line and Deer Kill Road and is at an elevation of 210-300 feet above mean sea level. Upper Three Runs and Crouch Branch are the major streams near the alternate site to the southeast. The alternate site is approximately 4 miles from the SRS boundary.

**Site Selection Process.** DOE conducted a screening process to select suitable sites for the APT. Using a process with several phases, the Department identified areas with suitable features and minimal conflicts with onsite resources and operational areas.

The first phase was the identification of basic land requirements. The minimum requirements assumed that an APT complex would include the following components:

- An accelerator in a long concrete tunnel approximately 40 feet below grade
- A building to house the target/blanket assembly
- A Tritium Separation Facility
- A radiofrequency tube remanufacturing and maintenance facility
- Facilities for the management of waste streams
- Administrative and infrastructure support facilities
- Cooling towers



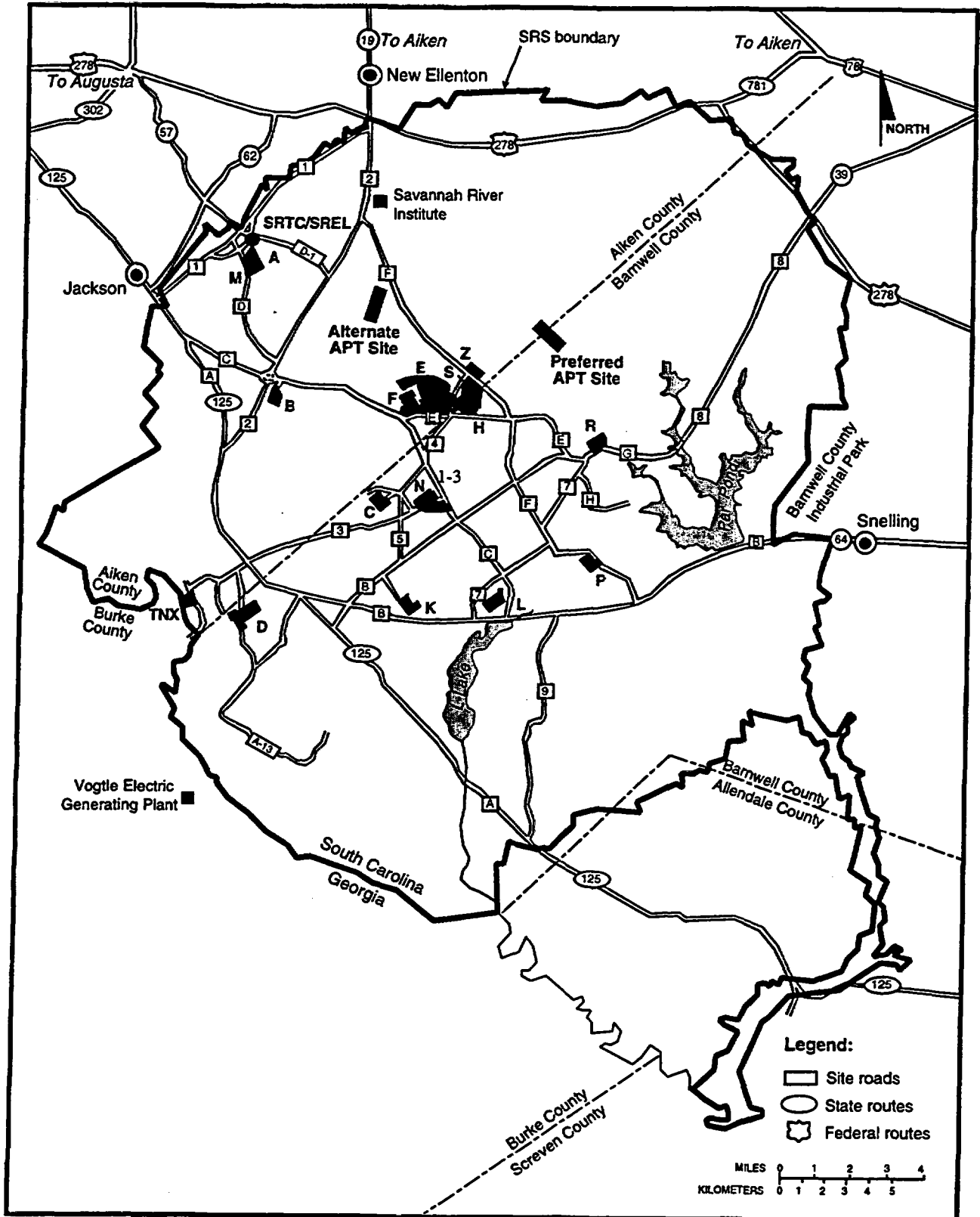

Figure 2-8. Approximate location of preferred and alternate sites for the APT.

PK68-Z1-PC

- Electrical substations
- Construction laydown yards

Based on these assumed components, DOE determined the APT complex would require approximately 250 acres of land with a footprint 6,560 feet long by 1,640 feet wide. The area requirements would not vary much with any combination of the technology or design options described in this chapter.

With the land requirements established, the next phase of the screening process was to develop exclusionary criteria (disqualifying conditions). Examples of these criteria include avoiding adverse impacts to threatened and endangered species, avoiding adverse impacts to wetlands and sensitive ecosystems, and proximity to seismic faults. Wike et al. (1996) contains a complete listing of these exclusionary criteria. Seven potential sites (numbered 1-7) were initially identified. Two sites (numbered 5 and 7) were subsequently eliminated due to the presence of disqualifying conditions (proximity to seismic faults). One site (number 8) was added based on a request to examine a site in the vicinity of A- and M-Areas. Although not explicitly used as exclusionary criteria, existing industrially developed areas were not examined as sites because of (1) the presence of existing operating structures, (2) the presence of non-operating structures that would require extensive decontamination and decommissioning (D&D) prior to site preparation, or (3) the presence of active environmental restoration activities.

The next phase of the screening process was to develop and apply a set of weighted selection criteria to the remaining sites. The selection criteria used are listed in Table 2-1. Each site was evaluated against these criteria using either quantitative analysis or the professional judgment of experts if quantitative information was not available.

The final phase of the screening process was to examine the results. One candidate (number 2) stood out and became DOE's preferred site.

**Table 2-1. APT site selection criteria.**

Category	Criterion
Ecology	Terrestrial ecology
	Aquatic ecology
	Wetland ecology
Human health	Distance to population center
	Distance to SRS boundary
	Existing facility incident impact (on APT)
Geology/Hydrology	Groundwater supply
	Depth to groundwater
	Stability of subsurface conditions
	Thermal capacity of soil
Engineering	Distance to RTF
	Distance to rail lines
	Archaeology
	Distance to acceptable road
	Terrain (including slope)
	Foundation conditions (subsidence tolerances)
	Distance to existing NPDES discharge point
	Distance to site utilities
	Distance to centralized sewage treatment plant tie-in
	Disruption to site infrastructure
	Presence of existing waste site

Sites 6, 8, and 4 were ranked next. Sites 1 and 3 scored substantially lower than the other sites. Site 6 is ranked second, with sites 8 and 4 close in ranking. However, site 4 scored the worst in subsurface stability and was dropped from further consideration when DOE decided that it preferred to use site 4 for other purposes. Site 8 was the only site that has an existing waste site located within the footprint. This left site 6 as DOE's choice for an alternate site.

Chapter 3 summarizes the existing environment for the preferred (site 2) and alternate (site 6) sites.

Because DOE has considered the preferred site for past missions, a considerable amount of information about the site is available. The information available for the alternate site is not quite as mature. Chapter 4 compares and contrasts the potential impacts of the construction

and operation of the APT at the alternate location with those for the preferred location.

### 2.3.6 ELECTRIC POWER SUPPLY ALTERNATIVES

The APT will require large amounts of electricity (up to 600 MWe peak load). Currently, the SRS obtains its electrical power from South Carolina Electric and Gas Company (SCE&G) through existing transmission lines and substations. As shown in Figure 3-12, both the preferred and alternate APT sites are in close proximity to existing electrical power supply lines.

In its consideration of electrical power sources, DOE has identified two alternatives:

- The Preferred alternative is to obtain electrical power from existing capacity and through market transactions
- An alternative is to obtain electrical power from construction and operation of a new coal-fired or natural gas-fired electricity generating plant. Should this alternative be selected, it could be a privatized action. Appropriate NEPA documentation would be tiered to this EIS.

Figure 2-9 illustrates the relationship of the APT to each of the electrical power alternatives. Section 4.1.4 discusses the range of possible electrical power requirements for the APT, and Section 4.4 discusses the impacts of providing electricity to the APT.

**Electricity from Existing Capacity and Through Market Transactions.** Under this alternative, the Department would use existing electrical transmission lines on the SRS to route power to the APT site. The APT sites are near suitable transmission lines to provide connections.

The SRS currently obtains its electrical power from South Carolina Electric and Gas Company; Section 3.3.6 contains a discussion of the power usage on the SRS and the electrical gen-

eration capacity of SCE&G. The Department could buy electrical power through competitive acquisition for the APT; however, under current State law regarding franchised service areas (Section 8093 of Public Law 100-202), competitive acquisition of power for the APT could only occur if SCE&G voluntarily relinquishes its exclusive service rights, South Carolina law is modified to accommodate a competitive acquisition, or federal legislation is passed specifying that the APT load can be competed (Exeter 1996). Because DOE believes that these actions to enable competitive acquisition are speculative, the Department has assumed that it would acquire power through SCE&G for the APT. SCE&G could supply power either through existing SCE&G capacity or through brokering power competitively acquired. In the latter case, SCE&G could pass the costs of acquiring the power to the Department or provide DOE with "retail wheeling services." Regardless of the ultimate source of electrical power (i.e., SCE&G or another utility who sells power to SCE&G who in turn sells the power to the Department), a new power plant would not be constructed specifically to meet the load requirements of the APT.

**Retail wheeling is a common utility practice of accepting power from or providing power to other utilities in times when system loads require augmentation or create a surplus. The receiving utility pays a negotiated price for the power and fees for the use of transmission and support systems.**

### **Construction and Operation of a New Electricity Generating Plant**

The Tritium Supply PEIS identified two types of potential electricity generating plants as reasonable options should a new plant be built.

As with the previous alternative discussed above, existing electrical transmission lines on the SRS would be used to route power to the APT. Under this alternative, a new electricity generating plant would be constructed to service the APT. The plant could be on the SRS or

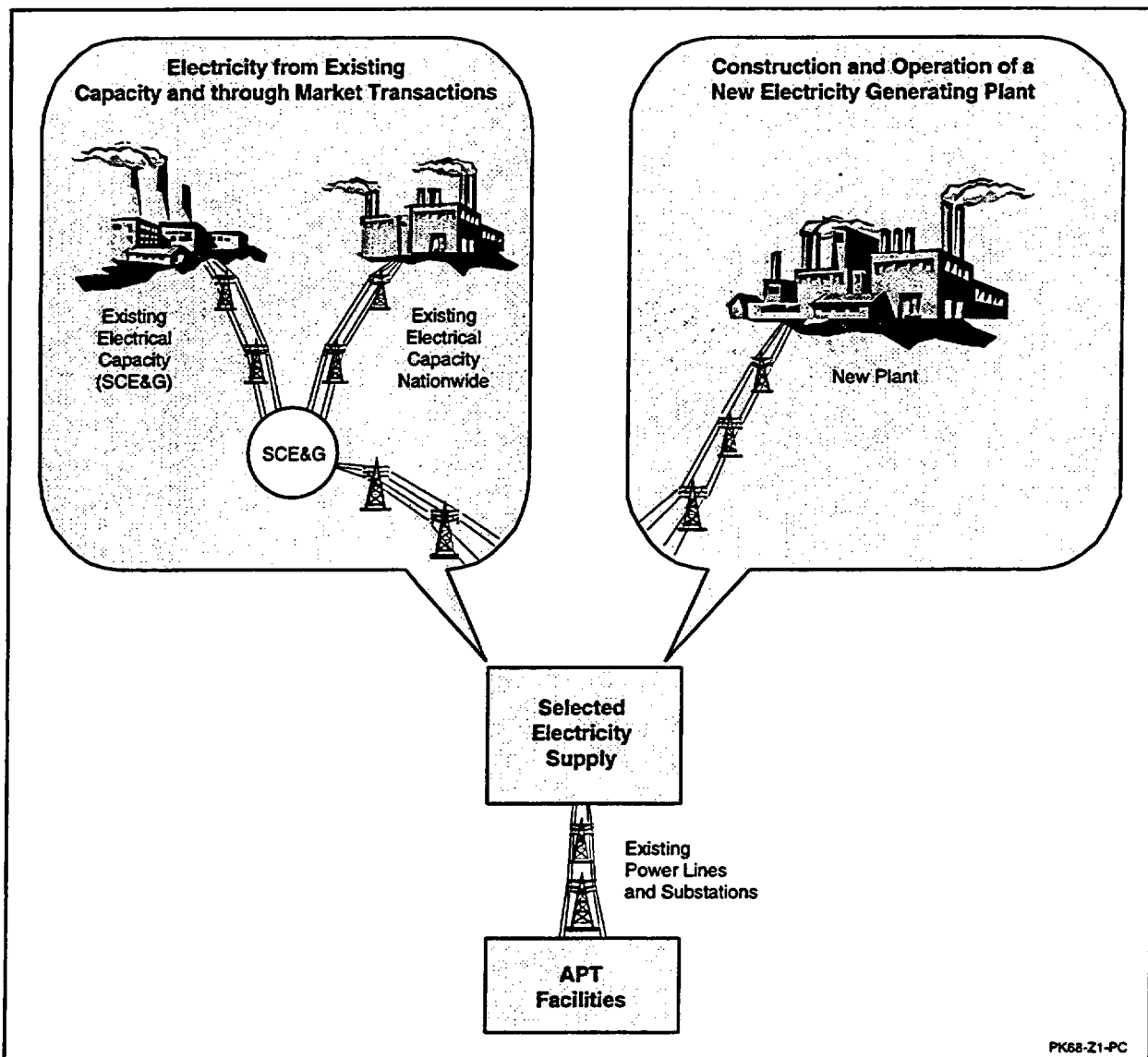

PK68-Z1-PC

Figure 2-9. Alternatives for supplying electricity to the APT. Existing transmission lines would be used and DOE would obtain power from existing plants and through market transactions or would obtain electricity from a new coal-fired or natural gas-fired plant.

located elsewhere. Two types of electricity generating plants could be used: (1) coal-fired, or (2) natural gas-fired.

The ultimate decision as to the type of generation facility used requires the consideration of many factors, including projected fuel costs, operation and maintenance costs, capital costs, engineering efficiencies, and operational requirements such as whether the facility should be base-load or load following. Coal-fired plants are historically the preferred method of

providing power to the region, especially with the decline in the nuclear sector. The majority of SCE&G's existing capacity is provided by coal power plants. Combined cycle gas-fired power plants provide certain advantages over coal-fired plants in terms of lower capital costs, emission rates, and plant efficiencies. However, the projected life cycle fuel costs associated with natural gas is higher and more volatile than that expected with coal (Beaman and Wade 1997). Section 4.4 presents the impacts for a generic coal-fired and natural gas-fired electric plant

that could supply power to the APT and for the purpose of estimating representative impacts, assumes SRS is the plant's location.

**Coal-fired Electricity Generating Plant.** The major components of a coal-fired electricity generating plant are: steam generator; turbine-generator; air emissions control system (dry scrubber and baghouse); stack; circulating water system for cooling; water supply; waste management and disposal facilities; fuel receiving, storage, and handling facilities. In addition to the above components, ancillary facilities for the plant as a whole would typically include access roads, parking areas, a railroad spur, switchyard, warehouses, and maintenance facilities. Approximately 290 acres of land would be required.

**Natural Gas-Fired Power Plant.** The Tritium Supply PEIS evaluated the impacts of constructing and operating a natural gas-fired electricity generating plant at the SRS. The facility description and summary of impacts are summarized in Section 4.8.2.2 of the Tritium Supply PEIS. In general, a gas-fired plant would consist of combustion turbines, a natural gas supply system, a fuel oil delivery and storage system for backup capacity, a water supply system, a demineralization system, and transmission distribution equipment. Ancillary facilities for the plant would include access roads, parking areas, warehouses, and maintenance facilities. Approximately 110 acres of land would be required.

## 2.4 Activities Associated with the Proposed Action and Alternatives

Section 2.3 describes the alternatives that DOE could implement if it decided to build an accelerator at the SRS, and describes facilities that DOE would construct to support specific alternatives. However, if DOE decided to construct an accelerator, it would construct several facilities in addition to those listed in Section 2.3 that would not depend on which of the alternatives

DOE implemented. In addition, DOE could modify several SRS facilities to provide support functions for the accelerator that would not depend on which alternative DOE implemented.

The following sections describe activities related to the construction and operation of new facilities and the use of existing facilities at the SRS that were not described in Section 2.3.

### 2.4.1 CONSTRUCTION AND OPERATION OF NEW FACILITIES

Based on the alternatives described in Section 2.3, DOE would perform the following construction activities to support one or more alternatives:

#### APT Site Improvements

1. Drainage for rain water during design-basis rainfall event
2. Tie-ins to SRS services, including roadways and bridges, rail service, utility power lines, sanitary sewer service, and domestic and River Water System
3. Buried utilities inside the APT boundary for communications, electric power, blowdown system, sanitary sewer, security monitoring, and heat removal piping
4. Parking facilities for operations and support personnel, and for visitors
5. Construction and operation of concrete batch plants to support APT construction
6. Construction and operation of a landfill for the disposal of construction waste

#### APT Site Facilities and Structures

The following subsections describe the major facilities that would be constructed as part of the APT. Figure 2-10 shows a conceptual illus-

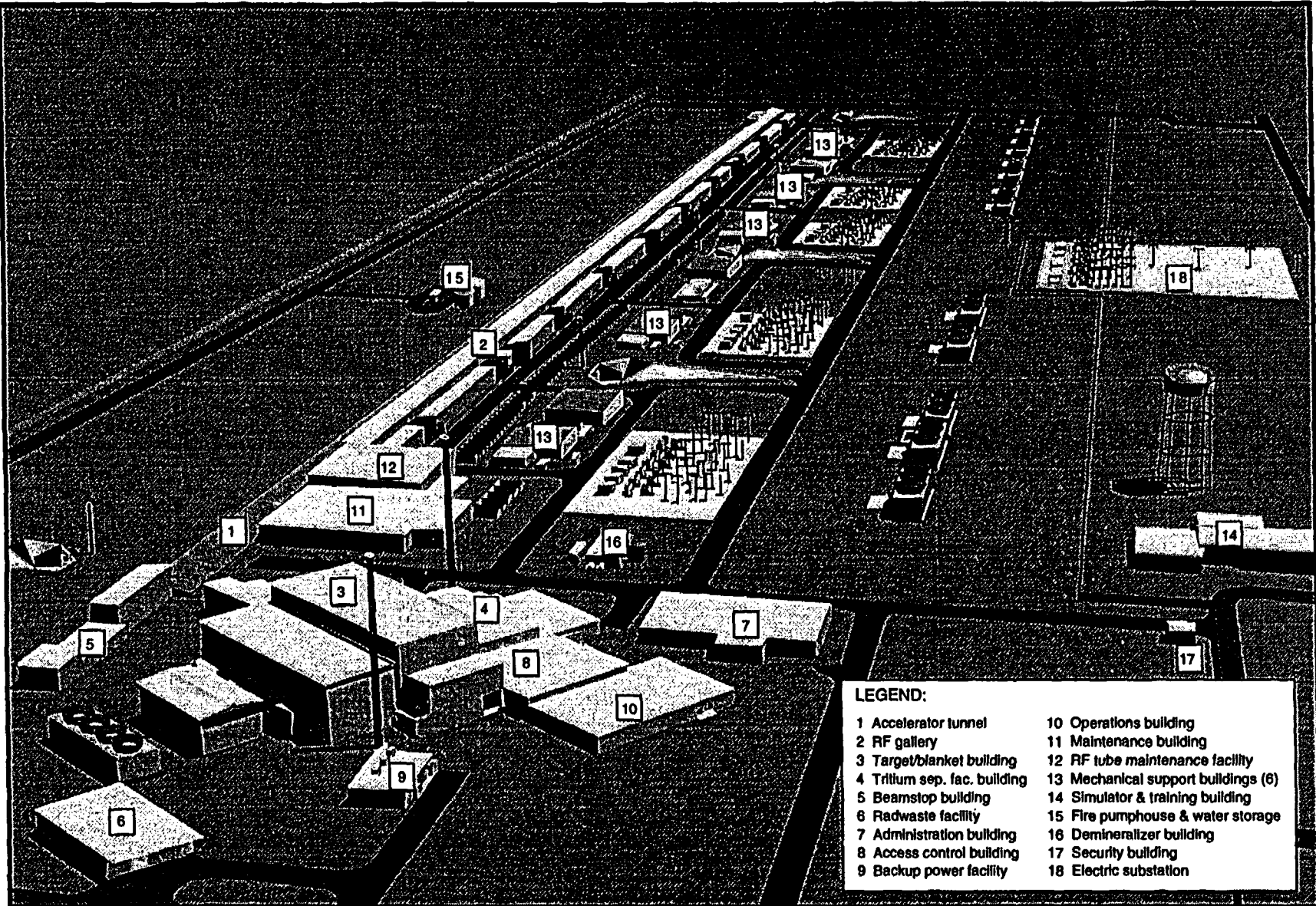

**LEGEND:**

1 Accelerator tunnel	10 Operations building
2 RF gallery	11 Maintenance building
3 Target/blanket building	12 RF tube maintenance facility
4 Tritium sep. fac. building	13 Mechanical support buildings (6)
5 Beamstop building	14 Simulator & training building
6 Radwaste facility	15 Fire pumphouse & water storage
7 Administration building	16 Demineralizer building
8 Access control building	17 Security building
9 Backup power facility	18 Electric substation

Figure 2-10. Conceptual layout of APT facilities and structure (LANL 1997).

PK68-Z1-PC

tration of the APT and the relative placement of these facilities.

1. Accelerator Tunnel: This subterranean (less than 40 feet below grade), rectangular, reinforced concrete structure would house accelerator components, and would have branches to the Target/Blanket Building and the Beamstop Building, as well as waveguide and electrical conduit penetrations to connect to the RF Gallery. An earthen berm of about 25-foot thickness over the main and high-energy tunnel sections would provide radiation shielding.
2. RF Gallery: This structure would extend the length of the injector and main acceleration tunnel sections adjacent to the tunnel berm. It would house the klystrons tubes or inductive output tubes and support systems that would supply radiofrequency power.
3. Target/Blanket Building: Located about 60 feet below grade, this facility would house the target and blanket systems. It would be of reinforced concrete and have three floors below grade and one floor above grade.
4. Tritium Separation Facility Building. The TSF building houses the tritium separation process. It would be located adjacent to the T/B building to minimize the length of piping runs. The facility would include a process area for the separation of Helium and tritium in a series of gloveboxes, an analytical laboratory, shipping area, maintenance glovebox, local control area, support center, and personnel areas and offices for the facility staff. The process area would be reinforced concrete shear wall construction and the balance of the building would be steel frame construction with architectural type siding.
5. Beamstop Building: This building would house the beamstop and its associated equipment. The building consists of two parts. The first part houses the beam expansion, the beamstop, and associated shielding. The second part of the building houses the beamstop heat removal systems.
6. Radioactive Waste Facility: This building would provide storage for packaged radioactive waste before shipment for final disposition, and would include monitoring facilities and offices.
7. Administration Building: This building would provide offices, conference rooms, lunchrooms, and medical facilities for the APT staff.
8. Access Control Building: This building would provide facilities for controlling access to the Tritium Separation Facility and the Target/Blanket Building.
9. Backup Power Facility: This structure would contain three diesel generators and supporting backup power equipment.
10. Operations Building: This building would provide office space, conference rooms, and a facility control room for the APT.
11. Maintenance Building: This building would provide facilities to perform maintenance, calibration, and assembly/disassembly activities.
12. RF Tube Maintenance Facility: This facility would provide space to repair and remanufacture radiofrequency power tubes or inductive output tubes.
13. Mechanical Support Buildings: These facilities would include components for high-volume air conditioning (HVAC) and heat removal. They would house circulation pumps, heat exchangers, water chillers, expansion tanks, and pressurization pumps.
14. Simulator and Training Building: This building would be outside the APT security perimeter; it would provide space for operator training and evaluation and for devel-

opment of new operational procedures, and would also serve as the visitors' center.

15. Fire Pump House and Water Storage Tanks: The pump house would contain fire protection equipment to support APT operations. The aboveground water storage tanks would hold water to support the fire protection system.
16. Demineralizer Building: This facility would house fixtures and equipment for the treatment and supply of makeup water for use in the closed-loop cooling systems.
17. Security Building: This building would house security personnel and facilities to control access and monitor the APT facility.
18. Electric Substation: Transformers in this facility would convert electric power from the 115-kilovolt power lines near the APT to the necessary voltages for the various equipment. All APT power would come from these power lines.

#### **2.4.2 USE OF EXISTING SRS FACILITIES TO SUPPORT APT OPERATIONS**

In designing the APT Project, DOE identified several areas on the SRS that contain facilities that it could use in APT operations. The descriptions of the alternatives in Section 2.3 mention facilities in H-Area (the Tritium Loading Facility and the Tritium Extraction Facility). DOE has also identified several functions that it could locate in M-Area. Table 2-2 lists the function description and the potential M-Area location(s) identified to accommodate the function (WSRC 1996b). If DOE determines that it should locate any of these functions in M-Area, it could modify the appropriate facilities to fulfill the new function. The modifications could include such activities as changing the facility layout, increasing the structural strength, installing mechanical equipment, upgrading or installing climate control systems, or installing safety equipment.

## **2.5 APT Design Variations**

This section describes the two potential design variations that could enhance the Department's flexibility to supply the nation's future tritium needs. The accelerator's inherent operational characteristics, hardware components, and support structures described elsewhere in this chapter, and in Appendix A, for the baseline accelerator design would be essentially the same as those for a modular accelerator. Section 2.5.1 summarizes the operational characteristics of the modular accelerator. Section 2.5.2 compares how tritium production could be increased from 1.5 to 3 kilograms per year for the baseline accelerator and the modular accelerator. The incorporation of the proposed Tritium Extraction Facility design into the APT is also discussed. While the specifics of the proposed TEF, as a stand-alone facility, is not discussed in this chapter or Appendix A, the extraction process and design is described in Section 2.5.3.

### **2.5.1 MODULAR OR STAGED ACCELERATOR CONFIGURATION**

The modular accelerator would be arranged in a straight line as would the baseline accelerator. It would use the same accelerator architecture, a normal-conducting low-energy linac injecting into a superconducting high energy-energy linac (see Section 2.3.2). As in the superconducting alternative for the baseline accelerator, the modular accelerator would require cryomodules. The accelerator current would be 100 mA. This level provides power for efficient operation for tritium goal quantity of 1.5 kilograms per year but is optimized at 3 kilograms per year. The nominal output energy for the initial stage would be 1015 MeV (WSRC 1997).

The target/blanket building, and much of the equipment contained therein would be sized to accommodate the full 3 kilograms per year production level and corresponding beam energy and power, as would the cavity vessel. The high energy beam stop would be designed to accommodate 2% of the beam power at full pro-



**Table 2-2.** APT Functions that could be located on the APT site or M-Area.

Function Description	Potential Location(s)
Construction staging	All facilities
Receipt/inspection of equipment	320-M 321-M 315-M
Storage of electrical and electronic equipment	320-M 321-M 313-M 315-M 330-M 331-M
Preoperational test verification of electrical and electronic equipment	320-M 321-M 313-M 322-M
Helium-3 piping fabrication and test (loop between blanket and Tritium Separation Facility) <sup>a</sup>	321-M
Control room simulator <sup>a</sup>	321-M
Program Development Center (develop computer software, receive and test new equipment, and ensure operability of Integrated Control System) <sup>a</sup>	320-M 321-M
Magnet equipment maintenance	320-M 321-M
Fabricate target/blanket components, piping assembled, steel assemblies, HVAC	320-M 321-M
Preoperational testing of vacuum valves	313-M 320-M 321-M
Training Facility <sup>a</sup>	313-M 320-M 321-M 305-1M
Target/blanket flow testing (testing for proper heat removal) <sup>a</sup>	320-M
Small-scale accelerator experiments to improve operation of APT <sup>a</sup>	313-M 320-M 321-M 322-M

a. Facilities which could be located on the APT site or at other locations.

duction levels (the same as the baseline accelerator). The target, decoupler, and inner-blanket modules would be designed for each production stage to optimize tritium production at the corresponding beam energy. The same blanket and shielding design would be used for all production levels. The window would be designed to accommodate the maximum beam power. The modular design would include a full production capacity tritium separation facility for Helium-3 feedstock material (WSRC 1997).

## 2.5.2 INCREASING TRITIUM PRODUCTION

In comparing upgrade configurations for the acceleration designs, baseline and modular, an

initial tritium goal quantity of 1.5 kilograms per year (Stage 1) is increased to 3 kilograms per year (Stage 2). In reality, however, additional staging could be at lower production levels.

For the baseline accelerator, the linac, high-energy beam transport, and the tunnels that house them, are in a straight line. A system design for tritium production at 3 kilograms per year determines the maximum energy of the accelerator, the length of the tunnel and RF gallery, and the location and size of the target blanket building. A staged baseline APT approach beginning with lower tritium production would be accomplished by building a lower energy accelerator; only as much linac equipment would be installed in the tunnel as needed to ac-

complete the beginning level of production (1.5 kilograms per year) but the structure would be able to accommodate 3 kilograms per year production levels. Initially, the remainder of the accelerator tunnel would contain only a quadrupole magnet transport system that conveys the beam to the high-level beam for the baseline 3 kilograms per year design. Effectively, the high-level beam transport is extended backwards to join up with the Stage 1 - 1015 MeV linac (see Figure 2-11). If the decision is made to increase production levels additional RF stations would be required, and in the case of the superconduction alternative, additional cryomodules. Tritium production would have to be suspended for a period of six-months to 1-year for the upgrades to take place (WSRC 1997).

In the case of the modular design variation, the accelerator, tunnel and RF gallery, and the cooling and electrical systems supporting the accelerator are built in Stage 1 to the length that matches the energy needed for the initial tritium production requirement. The beam transport line would connect to the target located in a separate offset tunnel parallel to the accelerator, but displaced horizontally by about 164 feet. The beam would bend 180 degrees to connect the ends of the linac stages to the transport beam lines. Since it only has to contain magnets, vacuum system, and beam diagnostics, this offset transport tunnel could have a much

smaller cross section than the baseline linac tunnel. A production upgrade would be accomplished by building additional modular sections of the linac, tunnel, RF gallery, and utilities, thus increasing the output beam energy to the level appropriate for the final production rate. A transfer line would connect the linac to the offset beam transport at the new output energy. If the upgrade is in more than one stage, multiple transfer lines could be built (see Figure 2-12). A design layout in which the linac and offset beam-transport tunnels are parallel and relatively close together minimizes the total length of the transfer lines and could simplify beam optics. Because the beam transport line is offset from the accelerator axis, the add-on linac for subsequent stages could be constructed in line with the Stage 1 linac, and operations could continue until the new section is ready to be connected and commissioned. Production downtime to increase tritium production levels for the baseline accelerator would be only weeks.

### 2.5.3 COMBINING TRITIUM EXTRACTION FACILITIES

As part of its dual-track decision described in Section 1.1 related to the Tritium Supply PEIS, DOE announced it would construct a Tritium Extraction Facility (TEF) at the SRS to support the commercial light-water reactor (CLWR)

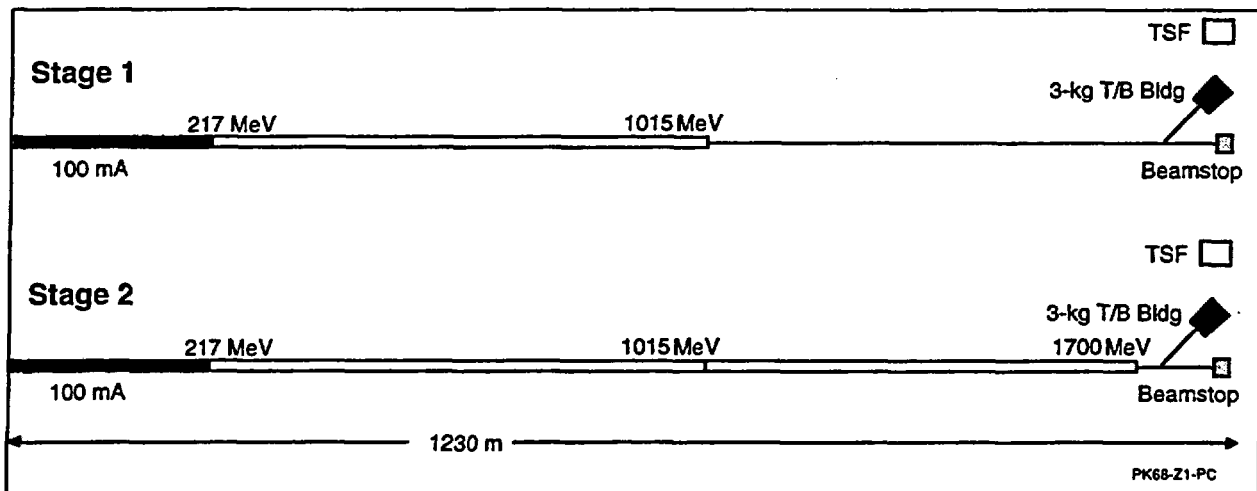

Figure 2-11. Staging with extended linac tunnel.

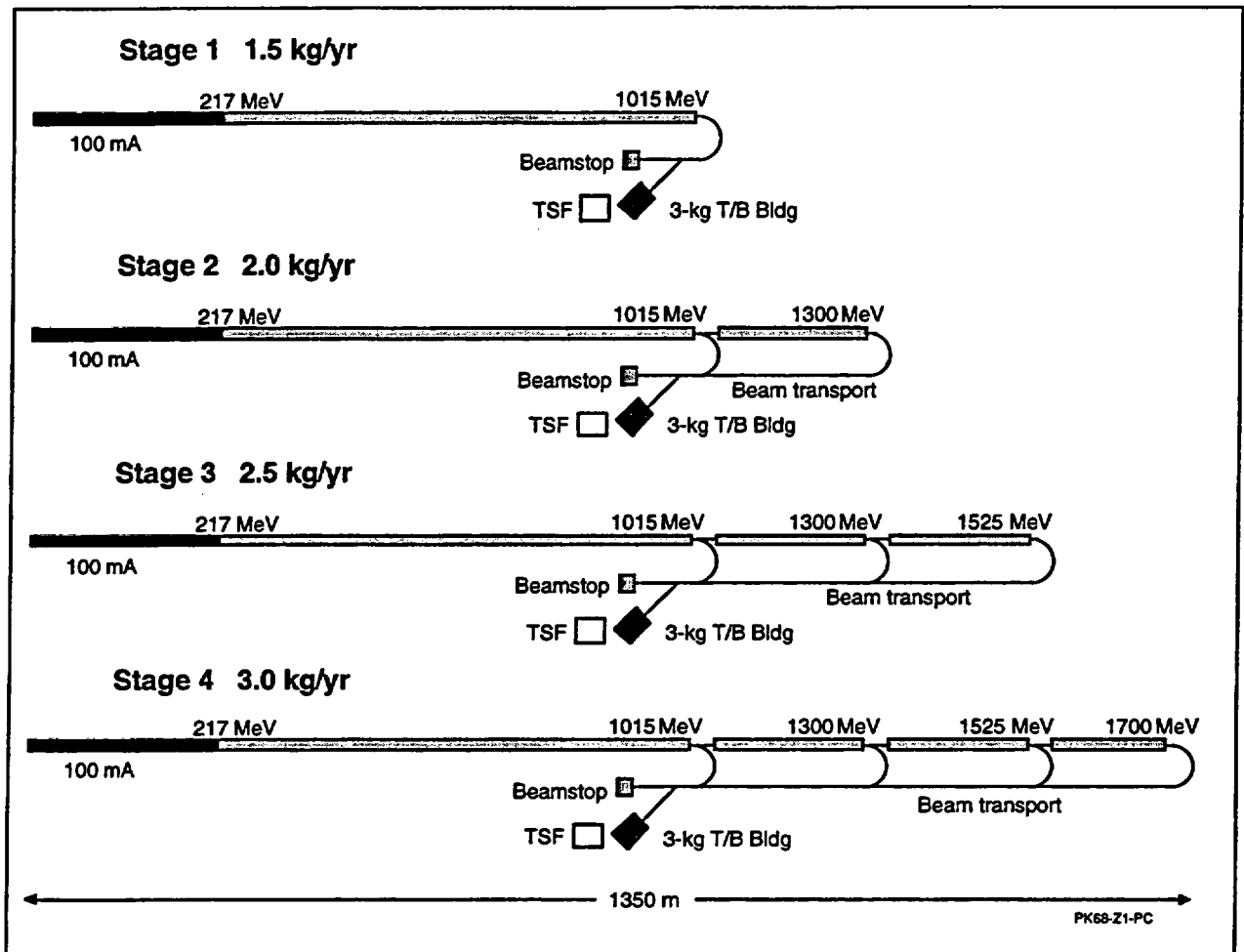

Figure 2-12. The modular configuration and possible stages of expansion.

track, if that was the track it chose. Since that decision, DOE issued a Notice of Intent (NOI) to prepare an EIS for the construction and operation of a TEF (see Section 1.5). DOE would build the TEF at the SRS to extract tritium from either CLWR target rods or the Lithium-6 feedstock material from the APT.

The Notice of Intent for the Tritium Extraction Facility explained the proposed action of constructing and operating a TEF that would be collocated with and would share common support facilities with Building 233-H at the SRS. As currently planned, the alternatives to the proposed action are: (1) not constructing and operating the TEF -- the No Action alternative and (2) upgrade and use of the existing Allied-General Nuclear Services facility located ap-

proximately one mile east of the SRS near Barnwell, South Carolina.

The process for completing the conceptual designs for the Accelerator for the Production of Tritium and the Tritium Extraction Facility identified an APT design option. This option would place the equipment necessary for extracting tritium from target rods irradiated in a commercial reactor or the Lithium-6 feedstock from the APT in the APT target/blanket building. In addition, the Tritium Separation Facility (TSF) would be built, regardless of the choice of feedstock material. The TSF handling and purification equipment would then be used to extract tritium from the CLWR or Lithium-6 rods.

This is an additional option from those presented in the Notice of Intent to prepare this EIS and the TEF EIS. If the APT is selected as the primary track for tritium supply, the Department would still need, in the case of a national emergency, capability to extract tritium from rods irradiated in a commercial reactor. This capability could be provided through this design option (i.e., combining the TEF with the APT) or one of the alternatives described in the TEF EIS.

While detailed technical data on the combining of the TEF and the TSF has not been finalized, the operational environmental impacts from this design option are not expected to significantly vary from the impacts for the baseline accelerator discussed in Chapter 4. As described below, this conclusion is based on the assumptions that the TEF and TSF will not operate at the same time and the administrative limit for tritium would be the same as that established for the APT without a TEF.

In the event tritium is produced in a commercial light-water reactor, DOE would ship the target rods from the CLWR to the SRS in a transport cask, remove the rods from the cask, and place them in dry storage to await extraction. DOE would prepare the rods for extraction by puncturing the cladding and cutting off the top ends, and then would place the rods in a double-vacuum extraction furnace that would drive off tritium and other gases. DOE would use the same process to purify the gases from the rods that it would use to extract tritium from the APT Helium-3 feedstock (Appendix A describes this process), and would move the purified tritium to the Tritium Loading Facility.

If Lithium-6 feedstock is used to produce tritium in APT, the tritium would be extracted in the same manner as described in Section 2.3.3, except that no transportation would be needed because equipment necessary to perform the operations would be colocated with the APT.

To accommodate this option, DOE would have to make the following modifications to the accelerator facilities:

- Increase the width of the target/blanket building.
- Create a new Tritium Extraction Pit in the target/blanket building and place the TEF remote handling functions and two furnaces in it.
- Place the TEF Water Cracker Room and associated equipment in the room previously identified as the APT Tritium Gas Storage Room; relocate the gas storage equipment to the new area (see above).
- Consolidate TEF requirements into the APT processes and complete appropriate modifications to the support systems.
- Design the TEF furnaces to process APT blanket modules to recover residual tritium implanted in the tubes (DOE 1997b).

The two processes -- target rod tritium extraction and Helium-3 tritium extraction -- could not operate concurrently. Specifically, DOE would complete the modifications listed above, but would not operate the TEF furnaces in parallel with the APT process.

Since the designed production capacity of the combination TEF-TSF would be the same as for the Helium-3 feedstock alternative without the TEF at the APT site, the expected releases of effluents as well as waste streams would also be the same as described in Chapter 4, as would be the consequences.

As a result, the radionuclide inventories used in the effluent calculations and accident analyses including the waste streams used in this document remain valid and encompass the combined facility.

## 2.6 Cost and Schedule

Information on the cost and schedule for the construction and operation of the APT can be found in the Conceptual Design Report (LANL 1997).

## 2.7 Comparison of Environmental Impacts Among Alternatives

Table 2-3 presents a comparison of the environmental impacts associated with construction and operation of the baseline APT as a function of alternative. For each technical discipline, the impacts of the Preferred alternative are discussed. The Preferred alternative is composed of the following:

- Klystron radiofrequency tubes
- Superconducting operation of accelerator structures
- Helium-3 feedstock material
- Mechanical-draft cooling towers with river water makeup
- Electricity from existing capacity and market transactions
- Use of the Preferred APT site

Differences in impacts that could occur if different alternatives were implemented are also presented.

Based on current design information, most of the potential environmental impacts of the two design variations (the modular APT design and combining tritium extraction facilities) are bound by the baseline APT.

In the case of the modular APT design, however, more land could be required. The potential socioeconomic impacts would initially be less. If the modular APT is expanded to 3 kilograms/year, socioeconomic impacts could extend beyond the construction period assumed for the baseline APT.

In general, DOE considers the expected impacts on the biological, human, and socioeconomic environment of construction and operation of an accelerator for production of

tritium at the SRS to be minor and consistent with what might be expected for any industrial facility. Construction and operation of the Preferred alternative would result in the loss of about 250 acres of mixed pine/hardwood upland forest. Waste would be generated during both the construction and operation phases but in quantities that would have negligible impacts on SRS waste management facilities. No high-level waste or transuranic waste would be generated during construction or operation.

Some small impacts from discharge of cooling water to SRS streams and from nonradiological emissions to air and water would occur. Radiological releases during normal operation of the facility are expected to result in no latent cancer fatalities in workers or the public. Because no high or adverse impacts are expected, no disproportionately high or adverse impacts on minority or low-income communities are expected.

Implementation of certain of the technology alternatives could result in impacts different from those resulting from construction and operation of the Preferred alternative. Most notable would be the impacts from implementation of cooling water system alternatives and electric power supply alternatives. Once-Through Cooling Using River Water would result in withdrawal from the Savannah River of about 125,000 gallons per minute of river water and discharge of hot water to the Par Pond system during operation. Thermal impacts would be restricted to the upper portions of the Par Pond system and would not affect Par Pond discharges to Lower Three Runs. There would be a small increase in Lower Three Runs flows, however. The implementation of the Mechanical-Draft Cooling Towers with Groundwater Makeup alternative would result in the withdrawal of 6,000 gallons per minute of groundwater. Total groundwater withdrawal at the SRS could therefore exceed the estimated groundwater production capacity of the aquifer. This could affect groundwater flow to site streams.

The Preferred alternative includes buying electricity from the commercial grid to support APT operation. In the case of commercial electricity purchases, the environmental impacts attributed to the APT load would be decentralized. In the case of the construction of a new electricity generating plant to support the APT, the environmental impacts would be localized at the site selected for the plant. Construction and operation of such a facility could require about 290 acres for a coal-fired plant and about 110 acres for a gas-fired plant.

Should the Department select the No Action alternative, design work on the APT would be concluded and the information archived. The APT would not be constructed at the preferred site and the 250 acres of land would revert to forestry or other uses. On-going SRS missions would continue. Incremental amounts of waste generation and electricity consumption that would have been attributable to the APT would not occur. Employment would be a function of on-going missions and funding levels.

**Table 2-3. Comparison of impacts among alternatives.**

Preferred alternative	Radio frequency power alternative	Operating temperature alternative	Feedstock material alternative	Cooling water system alternatives			Site location alternative	Electric power supply alternative
				Once-through using river water as makeup	Mechanical-draft using groundwater as makeup	K-Area cooling tower using river water as makeup		
Described in text	Inductive output tube	Room temperature	Lithium-6	Once-through using river water as makeup	Mechanical-draft using groundwater as makeup	K-Area cooling tower using river water as makeup	Alternate site	Construct new plant
<b>Impacts from Construction on Landforms, Soils, Geology, and Hydrology</b>								
Negligible impacts. Some 250 acres of land would be graded or leveled. No geologically significant formations or soils occur. Dewatering necessary. No surface faulting on site. Sites for electricity generation exist.	No change estimated from Preferred alternative	No change estimated from Preferred alternative	No change estimated from Preferred alternative	No change estimated from Preferred alternative	No change estimated from Preferred alternative	No change estimated from Preferred alternative	Water table is deeper and would require less dewatering; no other changes estimated from Preferred alternative.	Impacts would depend upon the specific location of a new facility. Could require about 110 acres for natural gas or 290 acres for coal.
<b>Impacts from Operation on Landforms, Soils, Geology, and Hydrology</b>								
No impacts No dewatering required for operations.	No change estimated from Preferred alternative	No change estimated from Preferred alternative	No change estimated from Preferred alternative	No change estimated from Preferred alternative	Removal of 6,000 gpm on a sustained basis could impact groundwater flow to streams and compact clay layers	No change estimated from Preferred alternative	No change estimated from Preferred alternative	Impacts would depend upon the specific location of a new facility
<b>Impacts from Construction on Surface Water</b>								
Negligible impacts. Dewatering of construction site could result in short-term increases in solids to the receiving water bodies.	No change estimated from Preferred alternative	No change estimated from Preferred alternative	No change estimated from Preferred alternative	No change estimated from Preferred alternative	No change estimated from Preferred alternative	No change estimated from Preferred alternative	No change estimated from Preferred alternative	Impacts would depend upon the specific location of a new facility

Table 2-3. (Continued).

Preferred alternative	Radio frequency power alternative	Operating temperature alternative	Feedstock material alternative	Cooling water system alternatives			Site location alternative	Electric power supply alternative
Described in text	Inductive output tube	Room temperature	Lithium-6	Once-through using river water as makeup	Mechanical-draft using groundwater as makeup	K-Area cooling tower using river water as makeup	Alternate site	Construct new plant
<b>Impacts from Operation on Surface Water</b>								
Blowdown rates (about 2,000 gpm) would cause negligible impact on surface water levels; using Par Pond as discharge point for cooling water. Temperatures would not exceed 90°F. Contaminated sediments would be resuspended in addition to radiological releases from APT.  Estimated fatal cancers: 0.00007	Would require 7% less cooling water than Preferred due to lower waste heat generation; no other changes estimated from Preferred alternative	Would require 33% more cooling water than Preferred; no other changes from Preferred alternative	No change estimated from Preferred alternative	Blowdown rates (about 125,000 gpm) would result in higher temperatures to water bodies (about 100° F). A slight increase in "pre-cooler" pond water levels would occur. No other changes estimated from Preferred alternative.	No change estimated from Preferred alternative	No change estimated from Preferred alternative	No change estimated from Preferred alternative	Discharges would be similar to the Preferred alternative, although concentrations would vary and be localized.
<b>Impacts from Construction on Nonradiological Air Emissions</b>								
Air emissions (fugitive dust and exhaust emissions) would be negligible, well below the applicable regulatory standards, electricity purchases, for impacts would be dispersed.	No change estimated from Preferred alternative	No change estimated from Preferred alternative	No change estimated from Preferred alternative	No change estimated from Preferred alternative	No change estimated from Preferred alternative	No change estimated from Preferred alternative	No change estimated from Preferred alternative	Emission types would be similar to the Preferred alternative, although concentrations would vary and be localized.
<b>Impacts from Operation on Nonradiological Air Emissions</b>								
No radiological emissions would be well within the applicable regulatory standards. Operations would result in small amounts of salt deposition and plumes from cooling-tower operations.	No change estimated from Preferred alternative	No change estimated from Preferred alternative	No change estimated from Preferred alternative	No change estimated from Preferred alternative	No change estimated from Preferred alternative	No change estimated from Preferred alternative	No change estimated from Preferred alternative	Nonradiological emissions would be well within applicable regulatory standards.



Table 2-3. (Continued).

Preferred alternative	Radio frequency power alternative	Operating temperature alternative	Feedstock material alternative	Cooling water system alternatives			Site location alternative	Electric power supply alternative
Described in text	Inductive output tube	Room temperature	Lithium-6	Once-through using river water as makeup	Mechanical-draft using groundwater as makeup	K-Area cooling tower using river water as makeup	Alternate site	Construct new plant
<b>Impacts from Construction on Radiological Air Emissions</b>								
No impacts; no radioactive materials stored during construction.	No change estimated from Preferred alternative	No change estimated from Preferred alternative	No change estimated from Preferred alternative	No change estimated from Preferred alternative	No change estimated from Preferred alternative	No change estimated from Preferred alternative	No change estimated from Preferred alternative	No change estimated from Preferred alternative
<b>Impacts from Operation on Radiological Air Emissions</b>								
Negligible impacts from radioactive airborne effluents  Latent Cancer Fatalities (L.C.F.'s) expected: 0.0006	No change estimated from Preferred alternative	No change estimated from Preferred alternative	Reduced doses from airborne emissions  L.C.F.'s expected: 0.00029	No change estimated from Preferred alternative	No change estimated from Preferred alternative	No change estimated from Preferred alternative	Higher doses from airborne emissions due to closer distance to SRS boundary  L.C.F.'s expected: 0.00065	Impacts would depend upon the specific location of a new facility. However, the dose from radioactive effluents would be negligible.
<b>Impacts from Construction on Land Use and Infrastructure</b>								
Conversion of 250 acres of forested land to industrial use. Additional roads, bridge upgrades, rail lines and utility upgrades would be required.	No change estimated from Preferred alternative	No change estimated from Preferred alternative	No change estimated from Preferred alternative	No change estimated from Preferred alternative	No change estimated from Preferred alternative	Additional cooling water piping to K-area needed.	No change estimated from Preferred alternative	Impacts would depend upon the specific location of a new facility. Could require conversion of up to 290 acres to industrial use.

Table 2-3. (Continued).

Preferred alternative	Radio frequency power alternative	Operating temperature alternative	Feedstock material alternative	Cooling water system alternatives			Site location alternative	Electric power supply alternative
Described in text	Inductive output tube	Room temperature	Lithium-6	Once-through using river water as makeup	Mechanical-draft using groundwater as makeup	K-Area cooling tower using river water as makeup	Alternate site	Construct new plant
<b>Impacts from Operation on Land Use and Infrastructure</b>								
No land use changes beyond construction. Electricity use: 3.1 terawatt-hrs	No change estimated from Preferred alternative	No change estimated from Preferred alternative Electricity use 23% higher than Preferred alternative	No change estimated from Preferred alternative	No change estimated from Preferred alternative	No change estimated from Preferred alternative	No change estimated from Preferred alternative	No change estimated from Preferred alternative	No change estimated from Preferred alternative
<b>Impacts from Construction on Waste Management</b>								
Small construction landfill required. Most waste generated would be solid waste and sanitary solid and liquid waste. Waste disposed at SRS.  (Annual Values) Sanitary solid: 560 cubic meters  Construction debris: 30,000 cubic meters	No change estimated from Preferred alternative	9% more waste generated due to greater construction activities required.	No change estimated from Preferred alternative	No change estimated from Preferred alternative	No change estimated from Preferred alternative	No change estimated from Preferred alternative	No change estimated from Preferred alternative	Additional construction waste generated from construction of facility.

Table 2-3. (Continued).

Preferred alternative	Radio frequency power alternative	Operating temperature alternative	Feedstock material alternative	Cooling water system alternatives			Site location alternative	Electric power supply alternative
Described in text	Inductive output tube	Room temperature	Lithium-6	Once-through using river water as makeup	Mechanical-draft using groundwater as makeup	K-Area cooling tower using river water as makeup	Alternate site	Construct new plant
<b>Impacts from Operation on Waste Management</b>								
<p>Would generate solid and liquid wastes, but no high-level or transuranic waste; waste volumes would have negligible impact on capacities of waste facilities.</p> <p>Generation of electricity will generate various types of waste including fly ash, bottom ash, and scrubber sludge.</p> <p>(Annual Values) Sanitary solid: 1,800 metric tons Industrial: 3,800 metric tons Radioactive wastewater: 140,000 gallons High concentration waste Greater-than-Class-C 15 cubic meters Sanitary wastewater: 3.3 million gallons Nonradioactive process wastewater: 920 million gallons</p>	No change estimated from Preferred alternative	37% more nonradioactive process wastewater required.	17% more low-level and 50% more high concentration mixed waste generated than Preferred alternative.	2,000% greater flow of nonradioactive process wastewater required.	No change estimated from Preferred alternative	No change estimated from Preferred alternative	No change estimated from Preferred alternative	Impacts would depend upon the type of power plant selected. However, waste rates for new power plant would not be very different than for the Preferred alternative.
<b>Impacts from Construction on Visual Resources</b>								
Negligible, facilities far from SRS boundaries and not visible to offsite traffic; facilities would look like other industrial areas at SRS.	No change estimated from Preferred alternative	No change estimated from Preferred alternative	No change estimated from Preferred alternative	No change estimated from Preferred alternative	No change estimated from Preferred alternative	No change estimated from Preferred alternative	No change estimated from Preferred alternative	Impacts would depend upon the specific location of a new facility

Table 2-3. (Continued).

Preferred alternative	Radio frequency power alternative	Operating temperature alternative	Feedstock material alternative	Cooling water system alternatives			Site location alternative	Electric power supply alternative
Described in text	Inductive output tube	Room temperature	Lithium-6	Once-through using river water as makeup	Mechanical-draft using groundwater as makeup	K-Area cooling tower using river water as makeup	Alternate site	Construct new plant
<b>Impacts from Operation on Visual Resources</b>								
Negligible, plumes from mechanical-draft cooling towers would be visible under certain meteorological conditions.	No change estimated from Preferred alternative	No change estimated from Preferred alternative	No change estimated from Preferred alternative	Negligible, would not generate visible plumes.	No change estimated from Preferred alternative	Plume from K-area cooling tower would likely be more visible.	No change estimated from Preferred alternative	Impacts would depend upon the specific location of a new facility
<b>Impacts from Construction on Noise</b>								
Noise primarily from construction equipment at API site. Not audible at SRS boundaries; however, construction workers could encounter noise levels that would require administrative controls or protective equipment.	No change estimated from Preferred alternative	No change estimated from Preferred alternative	No change estimated from Preferred alternative	No change estimated from Preferred alternative	No change estimated from Preferred alternative	No change estimated from Preferred alternative	No change estimated from Preferred alternative	Noise would be similar to Preferred alternative, but specific impacts would depend upon the location of a new facility
<b>Impacts from Operation on Noise</b>								
Noise from API equipment operation and traffic; mechanical-draft cooling towers largest single source, not audible at SRS boundary.	No change estimated from Preferred alternative	No change estimated from Preferred alternative	No change estimated from Preferred alternative	No mechanical-draft cooling tower noise at API site. Pump noise could be occasionally audible to river traffic.	No change estimated from Preferred alternative	No mechanical-draft-cooling tower noise at API site. Pump and cooling tower noise at K-area.	No change estimated from Preferred alternative	Noise would be similar to Preferred alternative, but specific impacts would depend upon the location of a new facility

Table 2-3. (Continued).

Preferred alternative	Radio frequency power alternative	Operating temperature alternative	Feedstock material alternative	Cooling water system alternatives			Site location alternative	Electric power supply alternative
				Once-through using river water as makeup	Mechanical-draft using groundwater as makeup	K-Area cooling tower using river water as makeup		
Described in text	Inductive output tube	Room temperature	Lithium-6	Once-through using river water as makeup	Mechanical-draft using groundwater as makeup	K-Area cooling tower using river water as makeup	Alternate site	Construct new plant
Impacts from Construction on Human Health								
Concentrations of nonradiological constituents would be less than applicable limits for workers and public. Traffic-related accidents resulting in about 2 fatalities to the public and workers due to increased local traffic would be reduced with finish of construction. Occupational injuries to workers would be due to industrial activities and would have the following impacts for the construction period:  Number requiring First Aid: 1,100  Number requiring medical attention: 280  Number resulting in lost work time: 93	No change estimated from Preferred alternative	Occupational injuries 6% less than Preferred alternative	No change estimated from Preferred alternative	No change estimated from Preferred alternative	No change estimated from Preferred alternative	No change estimated from Preferred alternative	No change estimated from Preferred alternative  Traffic fatalities 20% less than Preferred alternative	Impacts would be similar to Preferred alternative, but specific impacts would depend upon the location of a new facility

Table 2-3. (Continued).

Preferred alternative	Radio frequency power alternative	Operating temperature alternative	Feedstock material alternative	Cooling water system alternatives			Site location alternative	Electric power supply alternative
				Once-through using river water as makeup	Mechanical-draft using groundwater as makeup	K-Area cooling tower using river water as makeup		
Described in text	Inductive output tube	Room temperature	Lithium-6	Once-through using river water as makeup	Mechanical-draft using groundwater as makeup	K-Area cooling tower using river water as makeup	Alternate site	Construct new plant
<b>Impacts from Operation on Human Health</b>								
Public would receive source radiation exposure from AP1 emissions and transportation of radioactive material; workers would receive radiation exposure from facility operations and transportation of radioactive material and from electromagnetic fields.  Total ICI's to population (air, water, and transport) 0.0012  Total worker fatal cancers 0.04	No change estimated from Preferred alternative	No change estimated from Preferred alternative	No change estimated from Preferred alternative	No change estimated from Preferred alternative	No change estimated from Preferred alternative	No change estimated from Preferred alternative	No change estimated from Preferred alternative	No change estimated from Preferred alternative. Impacts would be local vs. dispersed for electricity generation.
<b>Impacts from Accidents on Human Health</b>								
Negligible consequences for accidents with frequency of less than once in operating lifetime of facility.	No change estimated from Preferred alternative	No change estimated from Preferred alternative	Minor decreases in accident doses for low probability events.	No change estimated from Preferred alternative	No change estimated from Preferred alternative	No change estimated from Preferred alternative	No change estimated from Preferred alternative	Accident consequences would be reduced since no radioactive material is involved.
<b>Impacts from Construction on Terrestrial Ecology</b>								
Would result in the loss of up to 250 acres of forested land; no marked reduction in plant/animal abundance or diversity.	No change estimated from Preferred alternative	No change estimated from Preferred alternative	No change estimated from Preferred alternative	No change estimated from Preferred alternative	No change estimated from Preferred alternative	No change estimated from Preferred alternative	No change estimated from Preferred alternative	No change estimated from Preferred alternative; specific impacts would depend upon the location of a new facility.

Table 2-3. (Continued).

Preferred alternative	Radio frequency power alternative	Operating temperature alternative	Feedstock material alternative	Cooling water system alternatives			Site location alternative	Electric power supply alternative
Described in text	Inductive output tube	Room temperature	Lithium-6	Once-through using river water as makeup	Mechanical-draft using groundwater as makeup	K-Area cooling tower using river water as makeup	Alternate site	Construct new plant
<b>Impacts from Operation on Terrestrial Ecology</b>								
Negligible impacts. Mechanical-draft cooling towers would result in salt deposition on vegetation; however, maximum rates (60 lb/acres/yr) are below threshold levels (180 lb/acres/yr).	No change estimated from Preferred alternative	No change estimated from Preferred alternative	No change estimated from Preferred alternative	No change estimated from Preferred alternative	No change estimated from Preferred alternative	No change estimated from Preferred alternative	No change estimated from Preferred alternative	Specific impacts would depend upon the location of a new facility
<b>Impacts from Construction on Wetlands Ecology</b>								
No impacts are projected from construction activities.	No change estimated from Preferred alternative	No change estimated from Preferred alternative	No change estimated from Preferred alternative	No change estimated from Preferred alternative	No change estimated from Preferred alternative	No change estimated from Preferred alternative	No change estimated from Preferred alternative	Specific impacts would depend upon the location of a new facility
<b>Impacts from Operation on Wetlands Ecology</b>								
Would result in minor impacts to wetlands. Temperature of the blowdown would be marginally higher than the ambient maximum temperature. During cooler months the warmth could have a positive impact by lengthening the growing season for some aquatic vegetation.	No change estimated from Preferred alternative	No change estimated from Preferred alternative	No change estimated from Preferred alternative	Would raise water level in Ponds 2 and 5 by 1.5 feet, possibly affecting wetland plant communities.	No change estimated from Preferred alternative	No change estimated from Preferred alternative	No change estimated from Preferred alternative	Specific impacts would depend upon the location of a new facility

2-36

Table 2-3. (Continued).

Preferred alternative	Radio frequency power alternative	Operating temperature alternative	Feedstock material alternative	Cooling water system alternatives			Site location alternative	Electric power supply alternative
Described in text	Inductive output tube	Room temperature	Lithium-6	Once-through using river water as makeup	Mechanical-draft using groundwater as makeup	K-Area cooling tower using river water as makeup	Alternate site	Construct new plant
<b>Impacts from Construction on Aquatic Ecology</b>								
Impacts to aquatic organisms in Upper Three Runs and tributaries would be minor due to use of soil and erosion control measures.	No change estimated from Preferred alternative	No change estimated from Preferred alternative	No change estimated from Preferred alternative	No changes estimated from Preferred alternative.	No change estimated from Preferred alternative	No change estimated from Preferred alternative	No change estimated from Preferred alternative	Specific impacts would depend upon the location of a new facility
<b>Impacts from Operation on Aquatic Ecology</b>								
Impingement (132 fish) and entrainment (173,000 fish eggs and 326,000 larvae annually) would not substantially affect Savannah River fisheries. Solids in blowdown would have no impacts on aquatic ecology. Discharge temperatures would have only small localized effects on aquatic communities.	No change estimated from Preferred alternative	No change estimated from Preferred alternative	No change estimated from Preferred alternative	Impingement (2,600 fish) and entrainment (3.4 million fish eggs and 6.4 million larvae annually) would be increased. Discharge temperatures would be high enough to adversely affect aquatic communities.	No change estimated from Preferred alternative	No change estimated from Preferred alternative	No change estimated from Preferred alternative	Specific impacts would depend upon the location of a new facility
<b>Impacts from Construction on Threatened or Endangered Species</b>								
Negligible, no threatened or endangered species at preferred site.	No change estimated from Preferred alternative	No change estimated from Preferred alternative	No change estimated from Preferred alternative	No change estimated from Preferred alternative	No change estimated from Preferred alternative	No change estimated from Preferred alternative	Negligible, no threatened or endangered species at alternate site.	Specific impacts would depend upon the location of a new facility



Table 2-3. (Continued).

Preferred alternative	Radio frequency power alternative	Operating temperature alternative	Feedstock material alternative	Cooling water system alternatives			Site location alternative	Electric power supply alternative
Described in text	Inductive output tube	Room temperature	Lithium-6	Once-through using river water as makeup	Mechanical-draft using groundwater as makeup	K-Area cooling tower using river water as makeup	Alternate site	Construct new plant
<b>Impacts from Operation on Threatened or Endangered Species</b>								
Negligible impacts to threatened and endangered species.	No change estimated from Preferred alternative	No change estimated from Preferred alternative	No change estimated from Preferred alternative	Fish kills in pre-cooler ponds could be beneficial to bald eagles. Heated discharges could force alligators to leave pre-cooler ponds in late summer.	No change estimated from Preferred alternative	No change estimated from Preferred alternative	No threatened or endangered species at alternate site.	Impacts would depend upon the specific location.
<b>Impacts from Construction on Socioeconomics</b>								
Increases in the work force for APT construction would not result in a boom situation.  Peak employment is about 1,400 jobs.	No change estimated from Preferred alternative	Employment would be lower.  Fewer jobs - about 100.	No change estimated from Preferred alternative	No change estimated from Preferred alternative	No change estimated from Preferred alternative	No change estimated from Preferred alternative	No change estimated from Preferred alternative	Peak workforce would be about 1,100 additional no change from Preferred alternative.
<b>Impacts from Operations on Socioeconomics</b>								
Operational work force about 500. No impacts.	No change estimated from Preferred alternative	No change estimated from Preferred alternative	No change estimated from Preferred alternative	No change estimated from Preferred alternative	No change estimated from Preferred alternative	No change estimated from Preferred alternative	No change estimated from Preferred alternative	Additional operational workforce about 200. No impacts.
<b>Impacts from Construction on Environmental Justice</b>								
No adverse impacts on minority or low-income populations expected.	No change estimated from Preferred alternative	No change estimated from Preferred alternative	No change estimated from Preferred alternative	No change estimated from Preferred alternative	No change estimated from Preferred alternative	No change estimated from Preferred alternative	No change estimated from Preferred alternative	Specific impacts would depend upon the location of a new facility.

Table 2-3. (Continued).

Preferred alternative	Radio frequency power alternative	Operating temperature alternative	Feedstock material alternative	Cooling water system alternatives			Site location alternative	Electric power supply alternative
Described in text	Inductive output tube	Room temperature	Lithium-6	Once-through using river water as makeup	Mechanical-draft using groundwater as makeup	K-Area cooling tower using river water as makeup	Alternate site	Construct new plant
<b>Impacts from Operations on Environmental Justice</b>								
No adverse impact on minority or low-income populations expected.	No change estimated from Preferred alternative	No change estimated from Preferred alternative	No change estimated from Preferred alternative	No change estimated from Preferred alternative	No change estimated from Preferred alternative	No change estimated from Preferred alternative	No change estimated from Preferred alternative	Specific impacts would depend upon the location of a new facility.

## References

- Beaman, J. Alan and S. H. Wade, 1997, "Energy Equipment Choices: Fuel Costs and Other Determinants," Energy Information Administration, Washington, D.C.
- DOE (U.S. Department of Energy), 1995, *Final Programmatic Environmental Impact Statement for Tritium Supply and Recycling*, DOE/EIS-0161, Office of Reconfiguration, Washington, D.C.
- DOE (U.S. Department of Energy), 1997a, *Final Environmental Impact Statement: Shutdown of the River Water System at the Savannah River Site*, DOE/EIS-0268, Savannah River Operations Office, Aiken, South Carolina.
- DOE (U.S. Department of Energy), 1997b, "APT/CLWR-TEF Scope Combination Study," M-ADS-X-00003, Savannah River Operations Office, Aiken, South Carolina.
- Exeter, 1996, "Estimated Power Supply Costs for the Accelerator Production of Tritium Project," Exeter Associates, Inc., Silver Springs, M.D.
- LANL (Los Alamos National Laboratory) 1997, Accelerator Production of Tritium Conceptual Design Report, LAUR97-1329, U.S. Department of Energy, Los Alamos, New Mexico, April.
- Wike, L. D., D. B. Moore-Shedrow, C. B. Shedrow, 1996, *Site Selection for the Accelerator for Production of Tritium at the Savannah River Site*, WSRC-TR-96-0279, Westinghouse Savannah River Company, Aiken, South Carolina, September.
- WSRC (Westinghouse Savannah River Company), 1996a, APT Cooling Water Supply Make-up Trade Study, Savannah River Site, Aiken, South Carolina.
- WSRC (Westinghouse Savannah River Company), 1996b, "Report on Use of Excess M-Area Facilities," SPM-TMD-96-0132, Savannah River Site, Aiken, South Carolina.
- WSRC (Westinghouse Savannah River Company), 1997, "APT Staging Comparisons," SPM-APT-97-0129, Savannah River Site, Aiken, South Carolina.

# Chapter 3

Affected Environment

---

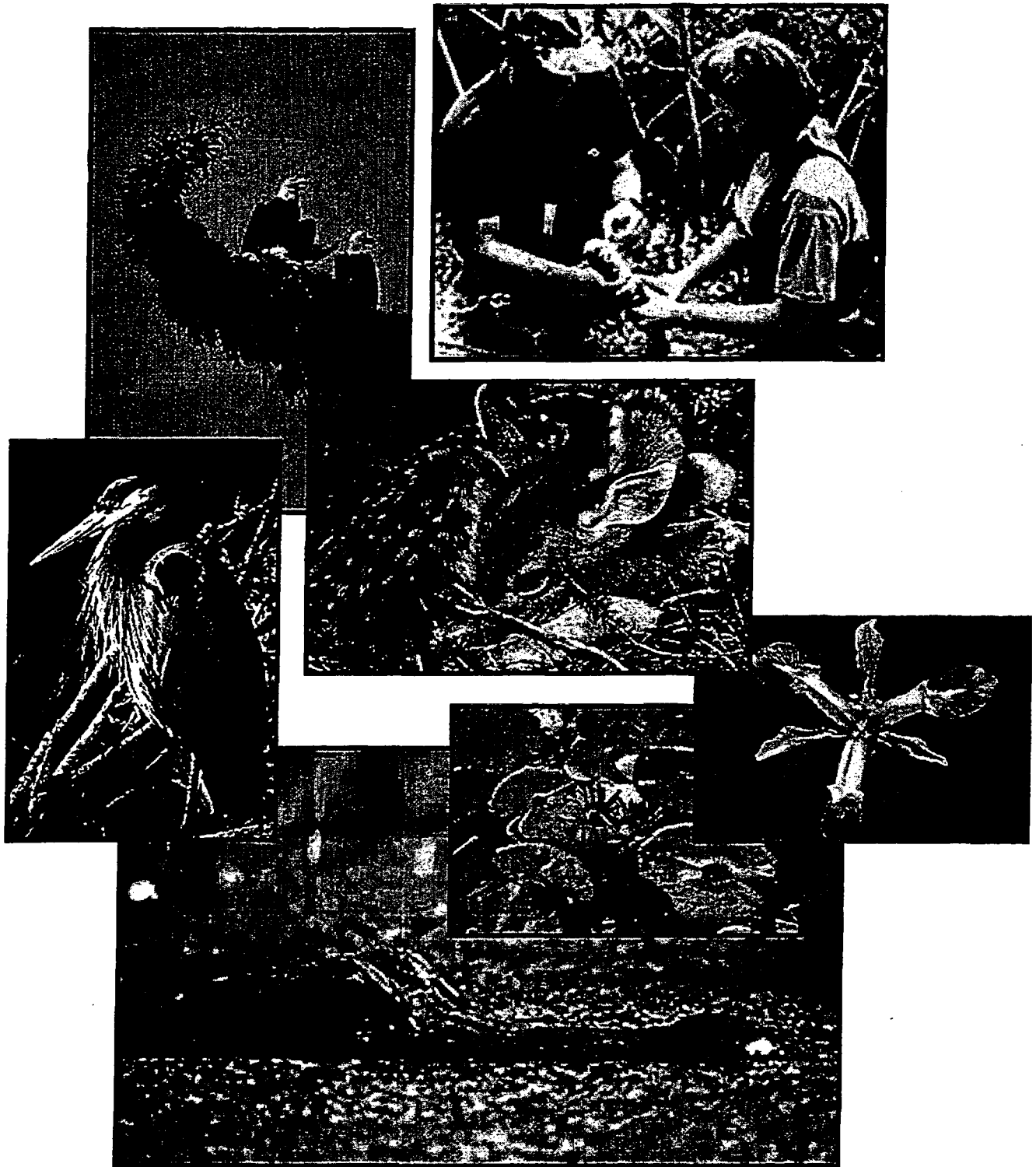

The Savannah River Site encompasses 198,000 acres in southwestern South Carolina. Industrial areas occupy approximately 17,000 acres and the remaining 181,000 acres are swamps and forest land inhabited by a rich array of plant and animal life.

## CHAPTER 3. AFFECTED ENVIRONMENT

The affected environment includes the physical and natural environment around the potential sites for the Accelerator Production of Tritium (APT) and the relationship of people with that environment. The descriptions in this chapter provide a basis for understanding the direct, indirect, and cumulative impacts of the proposed actions and alternatives. This chapter describes the existing situation for each environmental resource the construction and operation of the APT could affect. The depth of the descriptions varies depending on the relevance of the resource to the construction and operation of the APT.

The affected environment is the foundation or baseline for understanding potential impacts from the construction and operation of the APT. The information in this chapter comes primarily from the comprehensive environmental monitoring and surveillance programs that the U.S. Department of Energy (DOE) maintains at the Savannah River Site (SRS). In 1995, DOE performed effluent monitoring and environmental surveillance work within a 31,000-square-mile area around the SRS (extending as far as 100 miles) that includes cities, towns, and counties in Georgia and South Carolina.

This chapter describes the following:

- Land, biota, geology and soils, and cultural features for locations on the SRS that could host APT activities
- Site and regional ambient conditions for air, surfacewater, and groundwater supplies
- Socioeconomic conditions for the counties and communities that comprise the SRS region of influence; and projections of regional growth and related socioeconomic indicators

In addition, this chapter includes information on existing facility operations and the SRS infrastructure to provide a basis for an examination of the capacity of existing systems to handle projected waste streams, power and water requirements, and intrasite transportation.

### 3.1 Location of Proposed Actions

As mentioned in Chapter 1, DOE proposes to locate the APT, if it is built, on one of two sites on the SRS. Characterizations of the sites are described in the remainder of this chapter. See Section 2.3.5 for a description of the site selection process. Most APT support activities not located with the APT would be in either M- or H-Area. This section describes both areas. The remainder of the chapter contains more detailed information.

APT construction, operation, and support activities would occur primarily in three areas on the Savannah River Site:

- The APT site
- The existing industrialized M-Area
- The existing industrialized H-Area

The preferred APT site consists of about 250 acres of forested land north of the intersection of Roads F and E. The site, which is divided by the Aiken-Barnwell County line, is bordered on the southwest by a 115-kilovolt transmission line, a buried super control and relay cable, and Monroe Owens Road. Three other secondary roads, including E-2, cross the site. The alternate site consists of about 250 acres on a forested tract north of Upper Three Runs between Roads F and 2 (see Figure 2-8).

**M-Area.** M-Area (see Figure 3-1), an industrialized area consisting of existing buildings, paved parking lots and graveled areas, is the potential host for a number of APT support functions, as



3-2

Figure 3-1. M-Area (toward the southeast).

PK88-Z1-PC

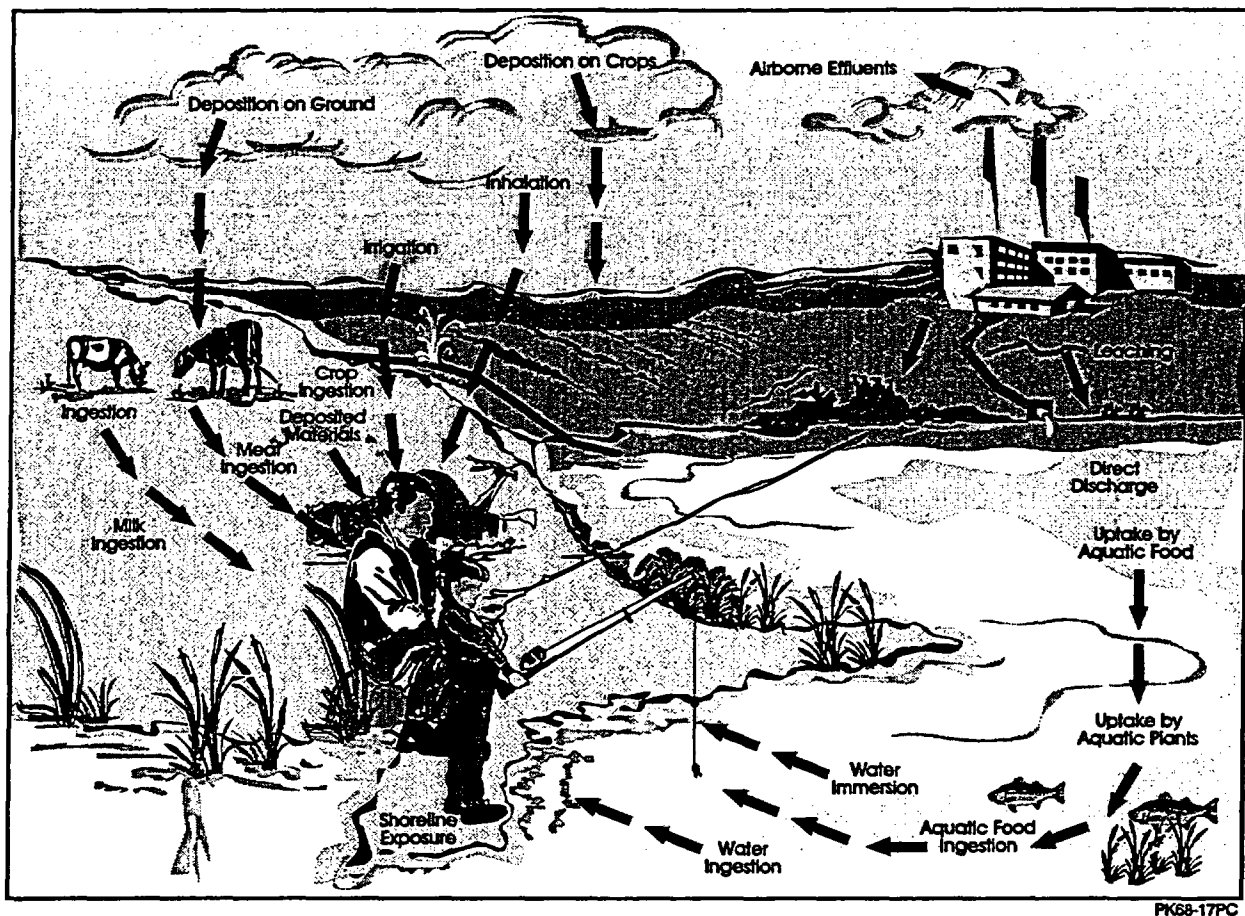

Figure 3-3. Common exposure pathways for radioactive effluents to reach members of the public.

nonradioactive liquid effluents are monitored at the point of discharge.

Similarly, the SRS maintains a radiological and nonradiological surveillance program that surveys and quantifies the presence of contaminants on the Site and the surrounding area. Sampled media include air, seepage basins, site streams, the Savannah River, drinking water, rainwater, sediment, soil, vegetation, food products, fish, deer, hogs, turkeys, and beavers. The nonradiological surveillance program involves sampling and analyzing site streams, the Savannah River, drinking water, sediment, groundwater, and fish for a number of chemicals and metals. The *Savannah River Site Environmental Report for 1995* (Arnett and Mamatey 1996) contains details on these programs.

**Effluent Monitoring** is the collection and analysis of samples or measurements of liquid and gaseous effluents to characterize and quantify contaminants, assess radiation exposure to members of the public, and demonstrate compliance with applicable standards.

**Environmental Surveillance** is the collection and analysis of samples of air, water, soil, foodstuffs, biota, and other media and the measurement of external radiation to demonstrate compliance with applicable standards, assess radiation exposures to members of the public, and assess effects, if any, on the local environment.

**Effluent Monitoring** occurs at the point of discharge, such as an air stack or drainage pipe; **Environmental Surveillance** involves looking for contaminants in the environment.



The information in the annual environmental report provides a picture of existing conditions at the SRS. Chapter 4 of this EIS describes potential impacts through each exposure pathway. A comparison of these impacts to the information in this chapter indicates the level of potential incremental effects the APT would have on the environment.

### 3.3 Physical and Manmade Environment

This section provides three types of information. First, it describes physical characteristics (geology, soils, and seismic considerations) that could influence the construction and operation of the APT. Second, it provides baseline air and water information because air and water are the media through which contaminants could reach people and animals. Third, it identifies man-made features at the SRS to provide a basis for understanding impacts the APT could have on the current infrastructure, as well as features from past Site inhabitation. It also discusses baseline noise levels from existing operations and visual considerations.

#### 3.3.1 LANDFORMS, SOILS, AND GEOLOGY

##### 3.3.1.1 Landforms

Both the preferred and alternate APT sites are on relatively flat, broad, and sandy upland areas typical of the Aiken Plateau portion of the Savannah River Site that formed in deep beds of marine sediments (Wike et al. 1994). The orientation of the APT footprint on the preferred site is from southeast to northwest; the footprint orientation on the alternate site is from southwest to northeast. Figure 3-4 shows the locations of the sites and their surface features (topography and nearby surface waters).

The elevation of the preferred APT site varies from about 300 to 330 feet above mean sea level (USGS 1987) with an average slope of less than 4 percent (WSRC 1991a). The upland ridge at the preferred site extends to the south

for a mile or more. However, 0.5 mile or more to the west, east, and north, the surface elevations start to drop more rapidly to the low-lying streams and headwaters prevalent in this area. Slopes range from 10 to 40 percent along the narrow steep-sided valleys between the upland areas and the flat floodplains along nearby Mill Creek, McQueen Branch, Tinker Creek, and Upper Three Runs.

The Upper Three Runs watershed drains both APT sites. Tributaries of Upper Three Runs in the area include Mill Creek and its headwaters to the east, McQueen Branch and its headwaters to the west, and Tinker Creek from the confluence of Mill Creek to the north (see Figure 3-4). Stream elevations range from about 250 feet above mean sea level at the headwaters to about 150 feet above mean sea level at the confluence of McQueen Branch and Tinker Creek. The watershed for the preferred APT site empties into Upper Three Runs just past the confluence of McQueen Branch and Tinker Creek. Upper Three Runs flows to the Savannah River. Figure 3-4 also shows the 100-year floodplain.

There is an upland Carolina bay with an area of about 15 acres approximately 0.3 mile north of the alternate site (WSRC 1996b). The alternate site ranges in elevation from about 200 feet above mean sea level at the south end to 310 feet above mean sea level at the north end (USGS 1987). The steepest slopes of the alternate site occur at the south end toward Upper Three Runs with a grade of nearly 17 percent. The upland area extends and rises to the north and there are low-lying wetland areas [ranging from 140 feet to 220 feet above mean sea level] within 0.5 mile to the east, west, and south. Similarly, the APT support operations proposed for M- and H-Areas would be on level topographic highs, but in existing heavily industrialized areas.

##### 3.3.1.2 Soil Conditions

The surface soils at the preferred APT site are nearly level to sloping and well-drained, with a sandy surface and subsurface layer and a loamy

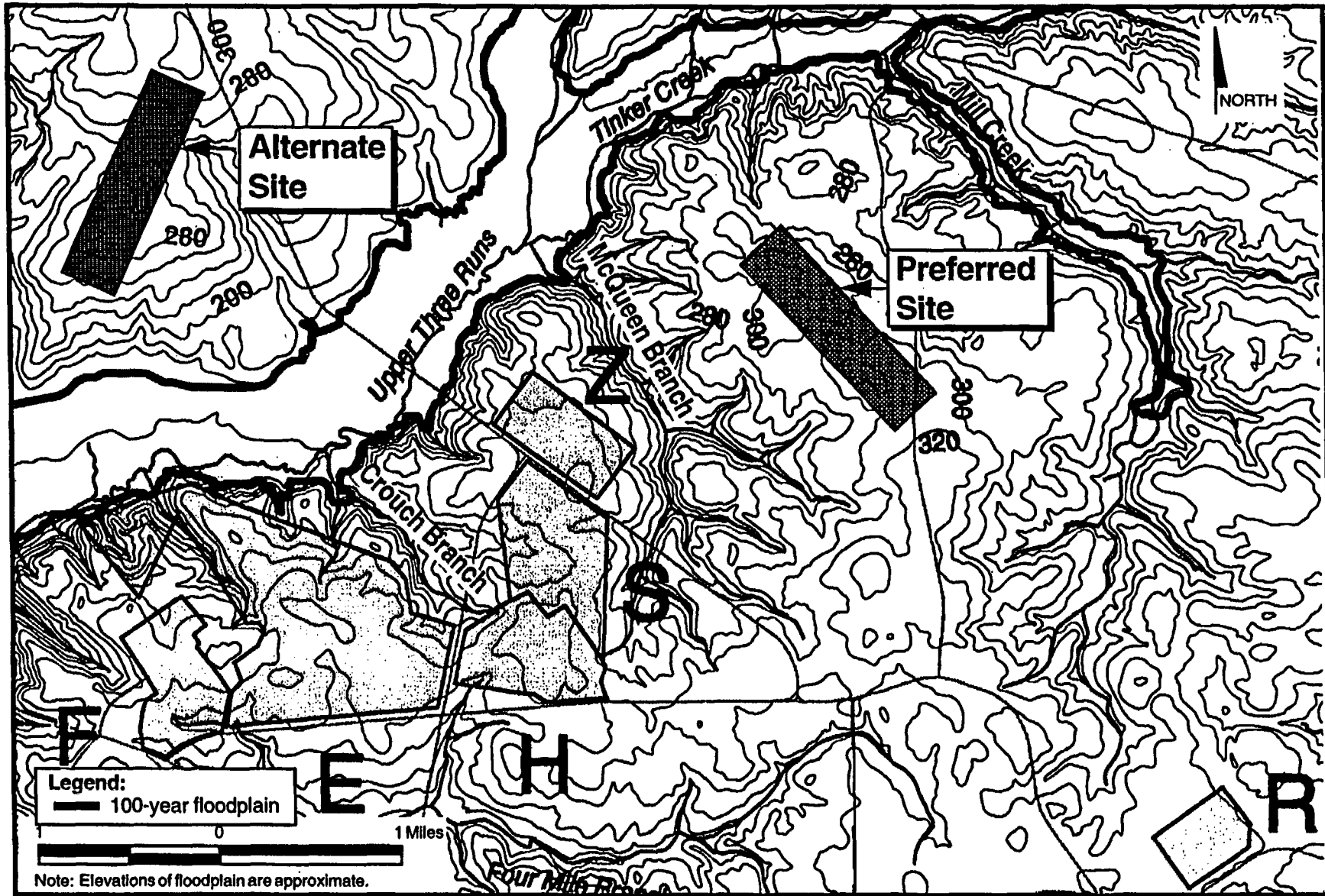

Figure 3-4. Land forms, topography, and 100-year floodplain of the preferred and alternate sites.

PK68-Z1-PC

subsoil (USDA 1990). The Fuquay sand (2 to 6 percent slopes) is the dominant soil mapping unit on the SRS, covering about 73 percent (about 180 acres) of the preferred site area. Figure 3-5, a soil survey map for the preferred and alternate sites, shows the boundaries of the soil mapping units. Table 3-1 lists the physical, chemical, and engineering features of Fuquay sand and other surface soils at the sites.

In general, the Fuquay sand, like the other soils that occur on the SRS, is well suited as habitat for open-land wildlife, fairly well suited as woodland wildlife habitat, and poorly suited as wetland wildlife habitat (USDA 1990). The slope is a moderate limitation affecting sites for buildings, but DOE could minimize this limitation by grading and shaping the land. The poorly drained Ogeechee sandy loam collects surface water during wet periods (USDA 1990). The seasonal wetness could be a severe limitation for buildings. This soil is fairly well suited as habitat for open land and woodland wildlife. It usually is well suited to wetland wildlife but not after periods of low rainfall, when some or all of the area will dry (USDA 1990).

In general, the soils at both APT sites range from nearly level to sloping and well-drained with a sandy surface and subsurface layer and a loamy subsoil. This soil is fairly suited to habitat for open land and woodland wildlife. It usually is well suited to wetland wildlife but not after periods of low rainfall, when some or all of the area will dry (USDA 1990). The slopes (2 to 6 percent) are moderate limitations affecting sites for buildings.

Surface soils at the alternate site are nearly identical to those at the preferred location. The Fuquay sand (2- to 6-percent slopes) is the dominant soil unit covering about 42 percent (approximately 104 acres) of the site. The physical, chemical, and engineering features and the uses of and management concerns about the surface soil at the alternate site are the same as those discussed for the preferred site, except there are no poorly drained soils within the alternate site boundaries (USDA, 1990).

DOE has evaluated the engineering properties of deeper soils near the preferred APT site to a depth of 50 feet (WSRC 1991a). In general, the soils from 0 to 50 feet range from silty sands to sandy clays with Atterberg liquid limit values (an index that is directly proportional to the compressibility of a soil) in the range of  $50 \pm 10$  percent, which indicates that these soils have moderate to high compressibility using mechanical compaction techniques during the preparation of deeper soils for supporting buildings and other structures (Sowers and Sowers 1961). Standard Proctor values for these soils range from approximately 101 to 107 pounds per cubic foot at 17 to 22 percent moisture. [Proctor values determine optimum-soil moistures and maximum densities for soil compaction during construction (Sowers and Sowers 1961)]. DOE has not characterized deeper soils at the alternate site.

The surface soils at the industrialized M- and H-Areas where APT support activities would occur are mostly well drained; these soils were formed from excavated areas, borrow pits, and other areas where major land-shaping or grading activities occurred. The soils are beside and under streets, sidewalks, buildings, parking lots, and other structures. Because this material has been moved, soil properties can vary within few feet. In general, the slopes of soils in these areas range from 0 to 10 percent with a moderate erosion potential. Soils range from sandy to clayey, depending on the source of the soil material (USDA 1990).

### 3.3.1.3 Geology, Hydrogeology, and Seismicity

**Geology.** The geology of SRS is well documented in publications such as the *Hydrogeologic Framework for West Central South Carolina* (Aadland, Gellici, and Thayer 1995). DOE used surface and deeper core borings and seismic survey techniques to characterize the geology at the preferred APT location and determined that this location is typical of the SRS. DOE has not characterized the alternate site, but based on a

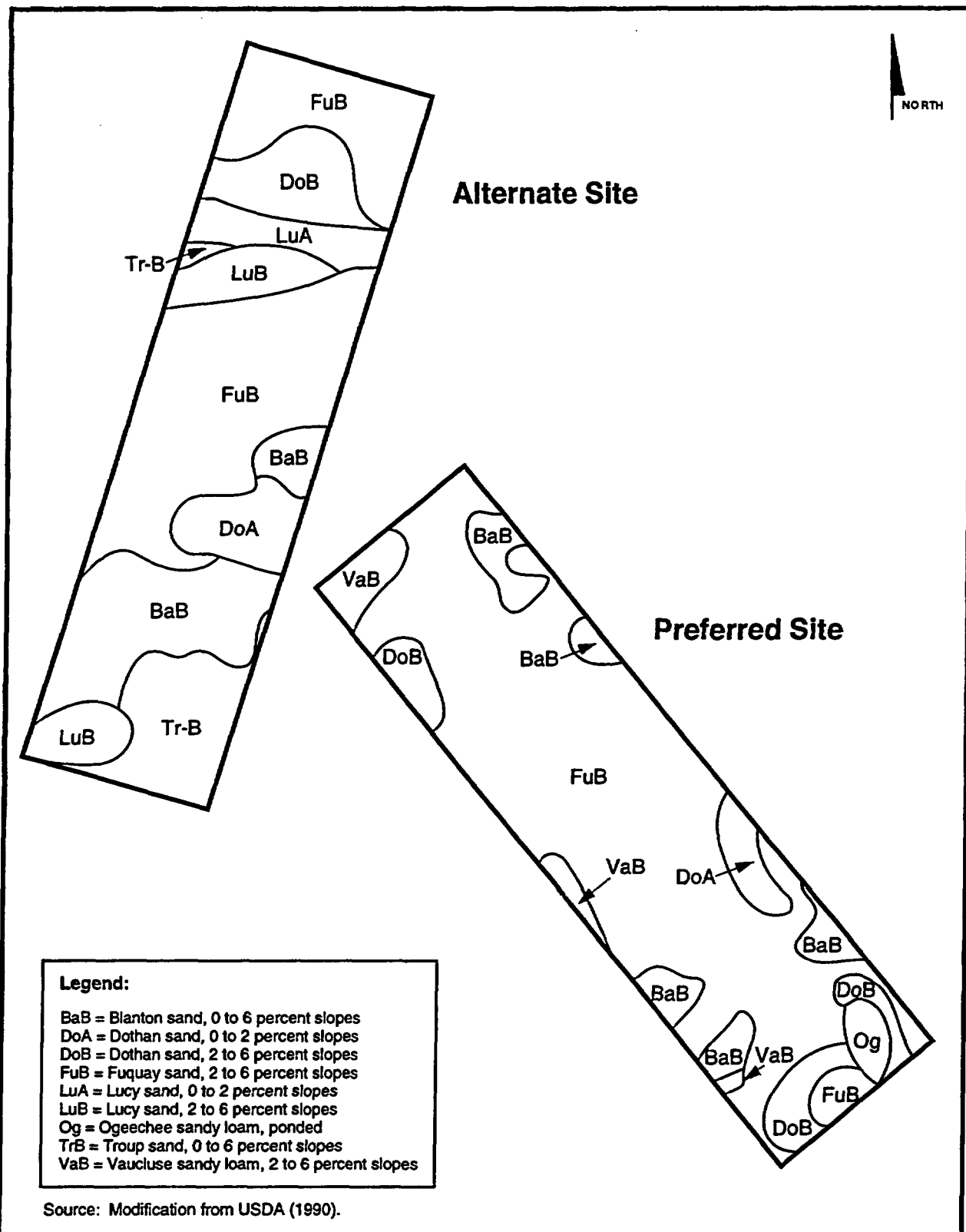

PK68-Z1-PC

Figure 3-5. Soil types at the preferred and alternate APT sites.

**Table 3-1. Summary of soils covering the APT sites.<sup>a</sup>**

Soil Name (soil mapping unit designation)	Relative surface area at APT sites (percent)		Erosion hazard	Soil texture			Soil reaction (pH)	Risk of corrosion	
	Preferred	Alternate		Surface	Subsoil	Drainage class		Uncovered steel	Concrete
Blanton sand, 0 to 6 percent slopes (BaB)	9	19	Slight <sup>b</sup>	Sandy	Loamy	Somewhat excessively drained <sup>c</sup>	4.5 - 6.0	High	High
Dothan sand, 0 to 2 percent slopes (DoA)	8	6	Slight	Sandy	Loamy and clayey	well drained <sup>d</sup>	3.6 - 6.0	Moderate	Moderate
Dothan sand, 2 to 6 percent slopes (DoB)	3	8	Slight	Sandy	Loamy and clayey	Well drained	3.6 - 6.0	Moderate	Moderate
Fuquay sand, 2 to 6 percent slopes (FuB)	73	42	Slight	Sandy	Loamy	Well drained	4.5 - 6.0	Low	High
Lucy sand, 0 to 2 percent slopes (LuA)	0	5	Slight	Sandy	Loamy and clayey	Well drained	4.5 - 6.0	Low	High
Lucy sand, 2 to 6 percent slopes (LuB)	0	7	Slight	Sandy	Loamy and clayey	Well drained	4.5 - 6.0	Low	High
Ogeechee sandy loam, ponded (Og)	2	0	Slight	Loamy	Loamy	Poorly drained <sup>e</sup>	4.5 - 5.5	High	High
Troup sand, 0 to 6 percent slopes (TrB)	0	13	Slight	Sandy	Loamy	Well drained	4.5 - 6.0	Low	Moderate
Vaocluse sandy loam, 2 to 6 percent slopes (VaB)	5	0	Moderate <sup>f</sup>	Loamy	Loamy and sandy	Well drained	3.6 - 5.5	Low	High
Vaocluse -Ailey complex, 6 to 10 percent slopes (VeC)	<1	0	Moderate	Loamy	Sandy, loamy, and clayey	Well drained	3.6 - 5.5	Low	High

a. Source: USDA 1990.

b. Slight = No particular erosion preventive measures are needed under ordinary farming practices.

c. Excessively drained = Water is removed from the soil very rapidly.

d. Well drained = Water is readily removed from a well drained soil, but not rapidly. It is available to plants throughout most of the growing season and wetness does not inhibit growth of roots for significant periods during the growing seasons.

e. Poorly drained = Water is removed so slowly that the soil is saturated periodically during the growing season or remains wet for long periods.

f. Moderate = Erosion control measures are needed for particular silvicultural activities.

review of the United States Geological Survey's *Preliminary Geologic Map of the Savannah River Site* (USGS 1994), DOE believes it is similar to the preferred location. The Gordon Confining Unit is thought to be thinner and less continuous laterally on the northern side of Upper Three Runs Creek and hence may be absent at that locality (Aadland, Gellici, and Thayer 1995).

A hard crystalline bedrock lies about 960 feet below the surface at the preferred APT site. Above the bedrock are several geologic formations comprised of layers and mixtures of sandy clays and clayey sands, although occasional beds of clays, silts, sands, gravels, or carbonate occur. In some cases, continuous clay layers act as confining units and restrict the upward or downward movement of groundwater below the APT site. The closest subsurface fault to the preferred APT site is more than 0.5 mile to the northeast.

Table 3-2 summarizes the geologic formations beneath the preferred APT site including the composition and depths of the formations. In addition, the information in the table is useful in understanding the geology of the alternate site.

A hard crystalline bedrock lies approximately 960 feet below the surface of the south end of the preferred APT site (WSRC 1997). Above the bedrock are 11 geologic formations comprised of layers and mixtures of sandy clays and clayey sands, along with occasional beds of clays, silts, sands, gravels, or carbonate. In some cases, continuous clay layers act as confining units and restrict the upward or downward movement of groundwater below the APT site.

**Hydrogeology.** Tables 3-3 and 3-4 summarize the water-bearing characteristics of the hydrogeologic units beneath the two APT sites and their significance as sources of water supply. In addition, the table lists typical SRS values for the hydrogeologic parameters of these units.

The depth to the top of the water table (Upper Three Runs Aquifer) averages 40 feet below the surface at the south end of the preferred APT

site and drops to around 60 feet at the north end (WSRC 1997). The water table aquifer extends down to the top of the Gordon Confining Unit and discharges into Tinker Creek north of the site and to the northeast toward Mill Creek, a tributary of Tinker Creek (WSRC 1991a).

As shown in Figure 3-6, the groundwater movement of the water table aquifer to nearby streams follows the downslope surface topography. However, the many lenses and discontinuous layers of clay, silt, and sandy/silty clay in the geologic formations associated with the aquifer affect the local movement of groundwater. Estimated flow rates for the water table aquifer range from 1.5 to 108 feet per year (WSRC 1991a). Using a flow rate of 108 feet per year, the estimated time for groundwater in the water table aquifer beneath the preferred APT site to reach Tinker Creek is 37 years. In addition, isolated zones of perched water (i.e., surface soils saturated with water) occur above the water table aquifer at the north and south ends of the preferred site (WSRC 1997).

The Gordon Aquifer, which is the first confined aquifer beneath the water table aquifer, is between the Gordon and Crouch Branch Confining Units. In the immediate vicinity of the preferred APT site, flow within the Gordon Aquifer is predominantly lateral with a slight upward flow gradient (WSRC 1991a). The Gordon Aquifer discharges, at least in part, to Tinker Creek, and has an estimated flow rate of 13.8 feet per year (WSRC 1991a). In the vicinity of the site, the Gordon Aquifer receives water from overlying and underlying units (Hiergesell 1997). The regional-scale direction of Gordon Aquifer flow at the SRS (i.e., the overall flow of the aquifer across the Site) is toward the Savannah River. The deeper confined aquifers beneath the preferred site flow southwest toward discharge zones in the vicinity of the Savannah River. Flow directions in these aquifers are not appreciably influenced by Upper Three Runs, as they are in the Gordon Aquifer. In addition, hydrogeologic investigations indicate that the deeper aquifers have an upward flow

**Table 3-2. Hydrogeologic units and associated geologic formations at preferred APT site.**

Unit <sup>a</sup>	Formation <sup>b</sup>	Depth and description <sup>b,c</sup>
Vadose Zone - unsaturated soils	Upland Unit	<ul style="list-style-type: none"> <li>• Depth below surface: 0 to 40 feet</li> <li>• Description: Very fine to medium grained, clayey sand overlain by one or more soil horizons.</li> </ul>
	Tobacco Road	<ul style="list-style-type: none"> <li>• Depth below surface: 10 to 110 feet</li> <li>• Moderately to poorly sorted red, brown, tan, purple and orange quartz sands.</li> </ul>
Upper Three Runs Aquifer	Dry Branch	<ul style="list-style-type: none"> <li>• Depth below surface: 40 to 60 feet</li> <li>• Description: Red to purple, fine to medium sands and sandy clays interbedded with purple and red clays. Thickness of Dry Branch formation ranged from 38 feet to 48 feet. Calcareous materials (e.g., cemented, fragmented shells, calcareous clayey sand, and calcite cemented sandstone) occur at 146 to 156 feet and 115 to 135 feet below ground surface.</li> </ul>
	Tinker/Santee	<ul style="list-style-type: none"> <li>• Depth below surface: 130 to 190 feet</li> <li>• Description: Fine to medium grained, white to pale green sand with some shell fragments. Thickness of Tinker/Santee Formation at site ranged from 24 feet to 49 feet.</li> </ul>
Gordon Confining Unit	Warley Hill <sup>d</sup>	<ul style="list-style-type: none"> <li>• Depth below surface: 160 to 200 feet</li> <li>• Description: Base of Santee is tight, sandy clay layer, 8 to 20 feet thick, called Warley Hill, which is major confining bed, 15.2 feet thick on average, continuous throughout APT site.</li> </ul>
Gordon Aquifer	Congaree	<ul style="list-style-type: none"> <li>• Depth below surface: 165 to 236 feet</li> <li>• Description: Green to orange, moderately well sorted, fine- to coarse-grained sand, with minor amounts of silt and clay. Average thickness of Congaree formation at APT site is 70 feet.</li> </ul>
Crouch Branch Con- fining Unit	Lang Syne/ Saw- dust Landing and Snapp <sup>d</sup>	<ul style="list-style-type: none"> <li>• Depth below surface: 215 to 320 feet</li> <li>• Description: Sequence of interbedded sands and clays. Sediments are generally light to dark gray, micaceous and lignitic. Lang Syne/Sawdust Landing and Snapp formations are major confining bed continuous throughout APT site with average thickness of 55 feet (ranging from 26 to 84 feet thick).</li> </ul>
Crouch Branch Aqi- fer	Steel Creek <sup>d</sup>	<ul style="list-style-type: none"> <li>• Depth below surface: 320 to 515 feet</li> <li>• Description: Light to dark gray, medium to very coarse, quartz sand with white to light gray kaolinitic clays.</li> </ul>
McQueen Branch Confining Unit	Black Creek	<ul style="list-style-type: none"> <li>• Depth below surface: 515 to 640 feet</li> <li>• Description: Gray to dark gray, medium to coarse quartz sands interbedded with medium to dark gray micaceous clays as much as 11 feet thick.</li> </ul>
McQueen Branch Aquifer	Middendorf	<ul style="list-style-type: none"> <li>• Depth: 640 to 840 feet</li> <li>• Description: Thick, variegated, brown, gray, red, and tan clay with gray to brown, silty fine to very coarse sands with zones of granules and pebbles. Several distinct clay layers occur in the Middendorf.</li> </ul>
Appleton Confining Unit	Cape Fear	<ul style="list-style-type: none"> <li>• Depth below surface: 842 to 960 feet</li> <li>• Description: Medium to dark gray, fine grained sand with dark gray clay.</li> </ul>
Piedmont Hydro- geologic Province	Bedrock	<ul style="list-style-type: none"> <li>• Depth below surface: 960+ feet<sup>e</sup></li> <li>• Paleozoic crystalline basement rock.</li> </ul>

a. Aadland, Gellici, and Thayer (1995) matches hydrogeologic nomenclature with geologic formations.

b. Unless indicated, WSRC (1991a) contains geologic formation names and descriptions.

c. Overlapping ranges in depths between formations are due to changes in surface elevation across preferred APT site and natural dip of geologic formations.

d. Aadland, Gellici, and Thayer (1995) contains revised nomenclature for formation names. Warley Hill Formation is commonly known as the Green Clay. Lang Syne/Sawdust Landing and Snapp Formations are commonly known as Williamsburg/Rhems Formations. Steel Creek Formation is commonly known as Pee Dee Formation.

e. WSRC (1997) contains depth to bedrock.

**Table 3-3. Water-bearing characteristics of the hydrogeologic units beneath the preferred APT site.<sup>a</sup>**

Hydrogeologic unit <sup>b</sup>	Hydrogeologic characteristics <sup>c</sup>	Significance as water supply <sup>c</sup>	Hydrogeologic parameters <sup>b</sup>
Vadose Zone	Unsaturated conditions exist except for isolated perched water zones at the north and south ends of the proposed APT site (WSRC 1997).	Not applicable.	Not applicable.
Upper Three Runs Aquifer	The Upper Three Runs Aquifer is the water table aquifer commonly referred to as the first unconfined aquifer. Discontinuous, low permeability, clay layers are common throughout the water table aquifer and they can serve to confine the groundwater occurring beneath them, on a local basis.	At the SRS, no water supply wells are known to be screened in the water table aquifer. Outside of the boundaries of the SRS, rural domestic and light industrial wells are screened in these aquifers.	Recharge rate: 15 inches per year Hydraulic conductivity <sup>c</sup> : 0.05 to 45.5 feet per day Transmissivity: 62 to 6,300 square feet per day
Gordon Confining Unit	This confining unit is continuous over at least the southeastern two-thirds of the SRS including the proposed APT site.	Not used as a source of water.	Leakance coefficient: $4.98 \times 10^{-5}$ per day Vertical hydraulic conductivity <sup>c</sup> : 0.00002 feet per day
Gordon Aquifer	Well yields as high as 660 gallons per minute with 50 feet of drawdown have been obtained near the center of SRS. Throughout the central portion of the SRS, the Gordon Aquifer flows toward either Upper Three Runs Creek or the Savannah river, which are discharge areas.	Regionally significant aquifer. The only drinking water supply wells screened in the Congaree aquifer at the SRS are at the Site perimeter patrol barricades.	Hydraulic conductivity: 24 to 41 feet per day Transmissivity: 1,124 to 13,400 square feet per day
Crouch Branch Confining Unit	This confining unit is mostly clay with some sand interbeds; usually considered to be an aquitard.	Not used as a source of water.	Leakance coefficient: $2.82 \times 10^{-6}$ per day Vertical hydraulic conductivity <sup>c</sup> : 0.000002 to 0.0034 feet per day
Crouch Branch Aquifer	Wells screened in the Crouch Branch Aquifer are capable of producing 500-600 gallons per minute. Groundwater at the SRS from the Crouch Branch Aquifer flows from north to south/southwest toward the Savannah River, which is its discharge area.	Regionally significant aquifer and provides drinking water to a large geographic area.	Hydraulic conductivity: 30 to 227 feet per day Transmissivity: 3,000 to 27,000 square feet per day
McQueen Branch Confining Unit	This confining unit consists of interbedded, silty, often sandy clay and sand beds.	Not used as a source of water.	Leakance coefficient: $1.03 \times 10^{-5}$ per day Vertical hydraulic conductivity <sup>c</sup> : 0.00007 to 0.02 feet per day
McQueen Branch Aquifer	Wells screened in the Middendorf are reported to produce as much as 3,000 gallons per minute. The aquifer associated with this formation is called the McQueen Branch Aquifer. Groundwater at the SRS from this aquifer generally flows from north to south and southwest toward the Savannah River, which is a discharge area for the aquifer.	A regionally significant aquifer.	Hydraulic conductivity: 53 to 210 feet per day Transmissivity: 14,000 to 50,100 square feet per day
Undifferentiated	Consists primarily of relatively low permeability clay and therefore acts hydraulically as a confining bed.	The Cape Fear is not used as a source of water.	Not applicable.

a. See Table 3.2 for a description of the associated geologic formations and approximate depths of these hydrogeologic units.

b. Source of information for column was Aadland, Gellici, and Thayer (1995) unless noted.

c. Source of information for column was WSRC (1991a) unless noted.



**Table 3-4. Water-bearing characteristics of the hydrogeologic units beneath the alternate APT site.<sup>a</sup>**

Hydrogeologic unit <sup>b</sup>	Hydrogeologic characteristics <sup>c</sup>	Significance as water supply <sup>c</sup>	Hydrogeologic parameters <sup>b</sup>
Vadose Zone	Unsaturated conditions exist except for isolated perched water zones at the north and south ends of the proposed APT site (WSRC 1997).	Not applicable.	Not applicable.
Steed Pond Aquifer	To the north of Upper Three Runs, the Gordon confining unit becomes discontinuous, allowing the Upper Three Runs Aquifer and the Congaree Aquifer (as described in Table 3-2) to merge into a single unit known as the Steed Pond Aquifer (Water Table). The groundwater flow in the Steed Pond Aquifer is towards Upper Three Runs with well yields similar to that of the Gordon Aquifer.	The upper portion of the aquifer is not suitable for wells due to low production capability. The lower portion of the aquifer could be used as a limited supply of water.	Recharge Rate: 15 inches per year Hydraulic Conductivity: 31.6 to 63.1 feet per day Transmissivity: 2500 to 5000 square feet per day.
Crouch Branch Confining Unit	This confining unit is mostly clay with some sand interbeds and is usually considered to be an aquitard.	Not used as a source of water.	Leakance Coefficient: $2.82 \times 10^{-6}$ per day Vertical Hydraulic Conductivity <sup>c</sup> : 0.000002 to 0.0034 feet per day
Crouch Branch Aquifer	Wells screened in the Crouch Branch Aquifer are capable of producing 500-600 gallons per minute. Groundwater at the SRS from the Crouch Branch Aquifer flows from north to south/southwest toward the Savannah River, which is its discharge area.	Regionally significant aquifer and provides drinking water to a large geographic area.	Hydraulic Conductivity: 30 to 227 feet per day Transmissivity: 3,000 to 27,000 square feet per day
McQueen Branch Confining Unit	This confining unit consists of interbedded, silty, often sandy clay and sand beds.	Not used as a source of water.	Leakance Coefficient: $1.03 \times 10^{-5}$ per day Vertical Hydraulic Conductivity <sup>c</sup> : 0.000007 to 0.02 feet per day
McQueen Branch Aquifer	Wells screened in the Middendorf are reported to produce as much as 3,000 gallons per minute. The aquifer associated with this formation is called the McQueen Branch Aquifer. Groundwater at the SRS from this aquifer generally flows from north to south and southwest toward the Savannah River, which is a discharge area for the aquifer.	A regionally significant aquifer.	Hydraulic Conductivity: 53 to 210 feet per day Transmissivity: 14,000 to 50,100 square feet per day
Appleton Confining Unit	Consists primarily of relatively low permeability clay and therefore acts hydraulically as a confining bed.	The Cape Fear is not used as a source of water.	Not applicable.

a. See Table 3.1 for a description of the associated geologic formations and approximate depths of these hydrogeologic units.

b. Source of information for column was compiled from Adland, Gellici, and Thayer (1995) unless noted.

c. Source of information for column was compiled from WSRC (1991a) unless noted.

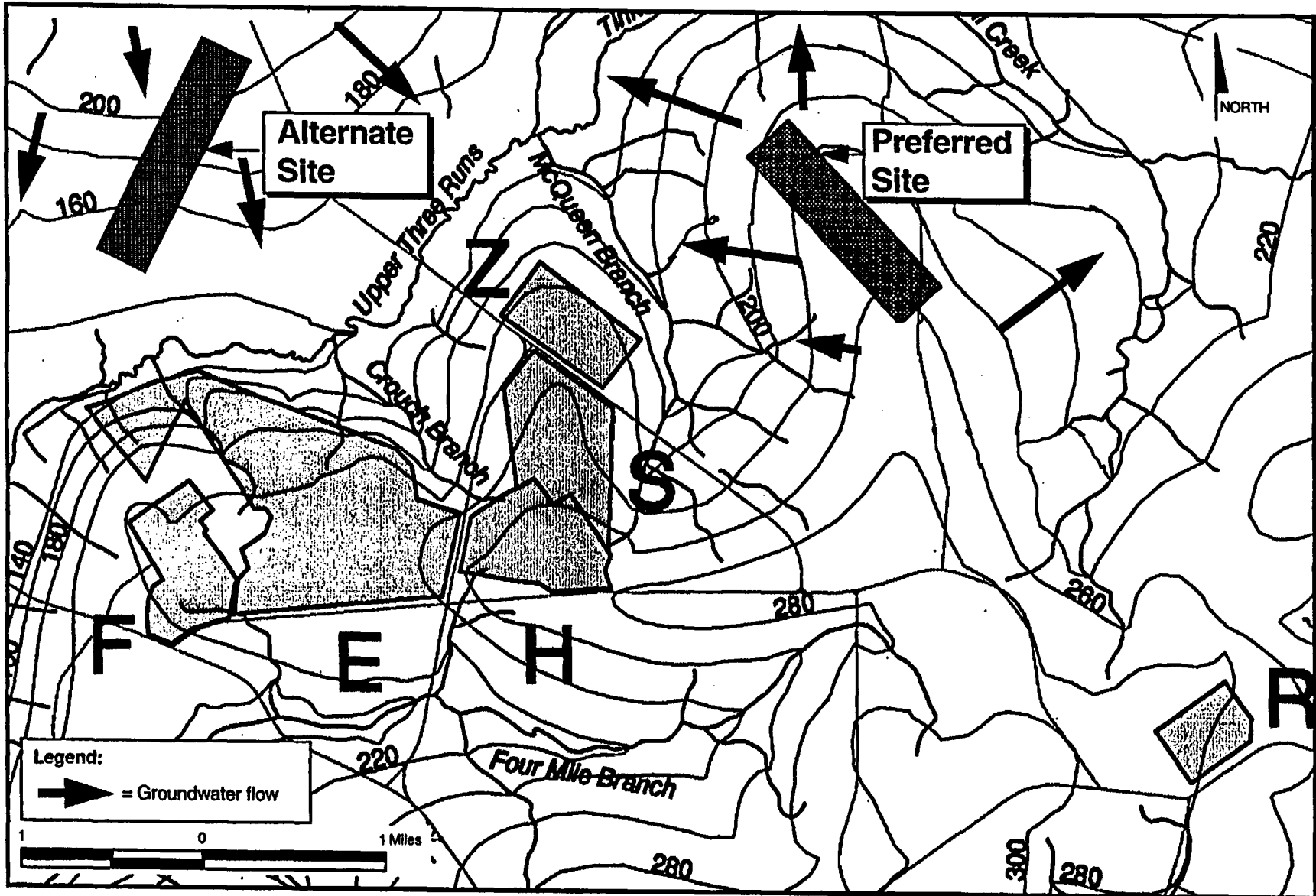

Figure 3-6. Water table elevations and groundwater flow in the water table aquifer at the preferred and alternate sites.

PK68-Z1-PC

gradient resulting in the potential for groundwater flow from the deeper aquifers to the shallower aquifers (WSRC 1991a).

The aquifers of interest for the alternate site include the Steed Pond Aquifer (water table aquifer), Crouch Branch Aquifer, and the McQueen Branch Aquifer. The Steed Pond Aquifer (the water table) is a merge of the Upper Three Runs and Gordon Aquifers due to the thinning or absence of the Gordon as a confining unit north of Upper Three Runs (see Table 3-4). The Crouch Branch Confining Unit, which separates the Steed Pond (water table aquifer) from the lower drinking water aquifer (Crouch Branch Aquifer), allows the migration of groundwater down from the overlying units. North of Upper Three Runs groundwater movement is upward across the Crouch Branch Confining Unit. This upward movement is due to the groundwater flow in the water table aquifer to streams such as Upper Three Runs. The result is an upward flow from the Crouch Branch to the water table aquifer that prevents the downward migration of contaminants to lower aquifer units (Aadland, Gellici, and Thayer 1995).

The depth to water at the alternate site is approximately 70 feet, 10 to 30 feet deeper than at the preferred site. The water table aquifer discharges to Upper Three Runs to the south and to two unnamed drainages to the east and west (Shedrow 1997).

**Seismicity.** There are several fault systems under and near the SRS (DOE 1990). A recent study of geophysical evidence (Stephenson and Stieve 1992) identified six subsurface faults -- Pen Branch, Steel Creek, Advanced Tactical Training Area, Crackerneck, Ellenton, and Upper Three Runs -- under the SRS. Figure 3-7 shows their locations. Lines on this figure represent projections of the subsurface faults to the ground surface; the actual faults do not reach the surface, but stop several hundred feet below. The closest subsurface fault to the preferred and the alternate APT sites is more than 0.5 mile away (WSRC 1996b). This deeper bedrock fault does not cut through the overlying unconsolidated sandy clays and clayey sands.

Based on the information developed to date, none of the SRS faults discussed in this section is capable. This means that none of these faults has moved at or near the ground surface within the past 35,000 years or was associated with another fault that had moved in the past 35,000 years. (10 CFR 100 contains a more detailed definition of a capable fault.)

Two major earthquakes have occurred within 186 miles of the SRS:

- The Charleston, South Carolina, earthquake of 1886 had an estimated Richter scale magnitude of 6.8; it occurred about 90 miles from the SRS area, which experienced an estimated peak horizontal acceleration of 10 percent of gravity (URS/Blume 1982).
- The Union County, South Carolina, earthquake of 1913, which had an estimated Richter scale magnitude of 6.0, occurred about 99 miles from the SRS (Bollinger 1973)

Because the earthquakes were not associated conclusively with a specific fault, researchers cannot determine the amount of displacement they caused. In recent years, three earthquakes occurred inside the SRS boundary.

- On June 8, 1985, an earthquake with a local Richter scale magnitude of 2.6 and a focal depth of 0.59 mile; its epicenter was approximately 8 miles southwest of the preferred APT site.
- On August 5, 1988, an earthquake with a local Richter scale magnitude of 2.0 and a focal depth of 1.66 miles; its epicenter was also more than 8 miles southwest of the preferred APT site.
- On May 17, 1997, an earthquake with a local Richter scale magnitude of 2.3 and a focal depth of 3.38 miles; its epicenter was more than 8 miles southwest of the preferred APT site.

Existing information does not relate these on-site earthquakes conclusively with known faults on the SRS. Figure 3-7 shows the locations of the epicenters of these earthquakes. Outside the Site boundary, an earthquake with a Richter scale magnitude of 3.2 occurred on August 8, 1993, approximately 10 miles east of the City of Aiken near Couchton, South Carolina. Residents reported feeling this earthquake in Aiken, New Ellenton (immediately north of the SRS), and North Augusta (approximately 25 miles northwest of the SRS), and on the Site. Figure 3-8 shows regional epicenters of seismic activity.

### 3.3.2 WATER RESOURCES

#### 3.3.2.1 Surface Water

The Savannah River is the principal surface water system associated with the SRS. Five of its major tributaries drain the Site and flow to the river. The *Final Environmental Impact Statement, Shutdown of the River Water System at the Savannah River Site* (DOE 1997) contains detailed information on SRS surface waters. The following sections provide information for water bodies that construction and operation of an accelerator could affect. Figure 3-9 shows the location of the Site's major water bodies and the 100-year floodplain. A more detailed floodplain map is found in Figure 3-4.

**Savannah River.** At the Site, river flows average about 10,000 cubic feet per second. River flows range from 3,960 to 71,700 cubic feet per second (Wike et al. 1994). Five upstream reservoirs (Jocassee, Keowee, Hartwell, Richard B. Russell, and Strom Thurmond/Clarks Hill) moderate the effects of droughts and the impacts of low flows on downstream water quality and fish and wildlife resources in the river (DOE 1990).

The Savannah River supplies potable water to several municipalities. Upstream from the SRS, the river supplies domestic and industrial water for Augusta, Georgia, and North Augusta, South Carolina. Approximately 126 river miles

downstream from the SRS, the river supplies domestic and industrial water needs for the Cherokee Hill Water Treatment Plant at Port Wentworth, Georgia, through intakes at River Mile 29, and for Beaufort and Jasper Counties in South Carolina through intakes at River Mile 39.2. In addition, the Vogtle Electric Generating Plant, across the river from the Site, and the Urquhart Steam Generating Station at Beech Island, South Carolina, withdraw an average 46 cubic feet and 265 cubic feet per second, respectively, for cooling.

The South Carolina Department of Health and Environmental Control (SCDHEC) regulates the physical properties and concentrations of chemicals and metals in SRS effluents under the National Pollutant Discharge Elimination System (NPDES) program. This agency also regulates chemical and biological water quality standards for SRS waters. Table 3-5 lists the water quality characteristics of the Savannah River upstream and downstream of the Site.

**Upper Three Runs.** Both proposed APT sites are in the Upper Three Runs watershed. Surface waters near the preferred site drain to Mill Creek and McQueen Branch, both of which flow to Tinker Creek and then to Upper Three Runs; the alternate site drains directly to Upper Three Runs. Upper Three Runs is a large, cool (annual maximum temperature of 79°F), black-water stream in the northern portion of the SRS. It drains an area of approximately 210 square miles and discharges directly to the Savannah River. Upper Three Runs is approximately 25 miles long, with the lower 17 miles within the Site boundaries. The average flow rate at Road A during the period from 1974-1995 was 245 cubic feet per second (Cooney et al. 1995).

Upper Three Runs receives more water from underground sources than other SRS streams and, as a result, has low conductivity, hardness, and pH values. It is the only major tributary on the SRS that has not received thermal dis-

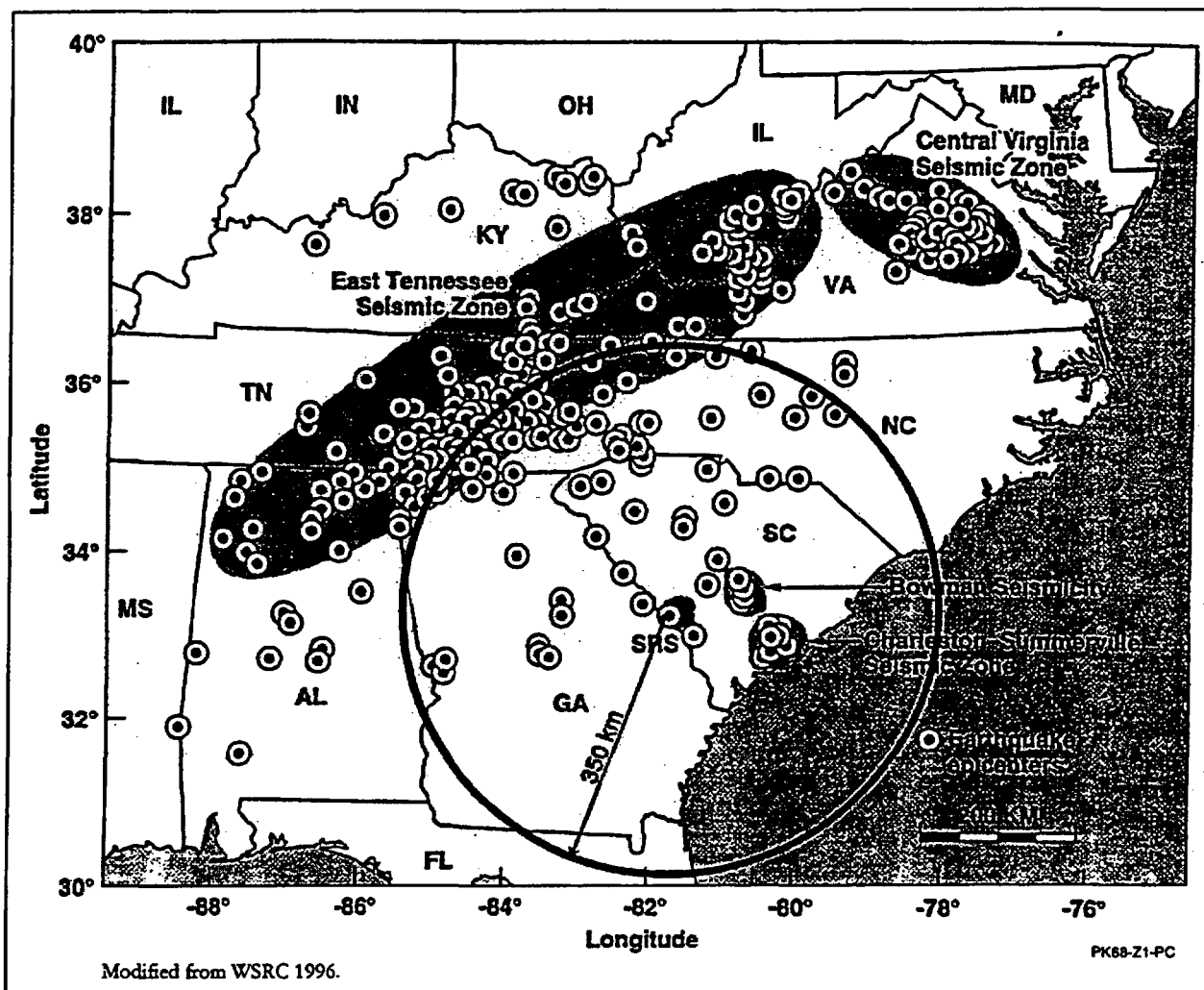

Figure 3-8. Regional epicenters of seismic activity.

charges from onsite activities. It does receive surface runoff and water from NPDES-permitted discharges in A-, E-, H-, M-, S-, and Z-Areas. Monitoring studies indicate no adverse impacts to Upper Three Runs water quality from SRS operations in these areas (Wike et al. 1994). Table 3-6 characterizes the water quality in Upper Three Runs at Road A.

**Pen Branch and Indian Grave Branch.** Pen Branch and its tributary, Indian Grave Branch, drain an area of about 21 square miles. Pen Branch is approximately 15 miles long and flows in a southwesterly direction from its headwaters about 2 miles northeast of K-Area to the Savannah River Swamp. After entering the swamp, the creek flows parallel to the Sa-

vannah River for about 5 miles before it enters and mixes with the waters of Steel Creek about 0.2 mile from the mouth of Steel Creek. In its headwaters, Pen Branch is a largely undisturbed blackwater stream. Until K-Reactor shut down in 1988, Indian Grave Branch received thermal effluent from that facility. The reactor discharge increased flow from natural levels of 10 cubic feet per second to 400 cubic feet per second. At present, Indian Grave Branch receives nonthermal effluents of nonprocess cooling water, ash basin effluent waters, powerhouse wastewater, and sanitary wastewater from K-Area and sanitary effluent from the Central Shops Area (Wike et al. 1994). Table 3-6 lists the characteristics of Pen Branch at Road A-17.

Table 3-5. Water quality in the Savannah River upstream and downstream from SRS (calendar year 1995).<sup>a,b</sup>

Parameter	Unit of measure <sup>c</sup>	MCL <sup>d,e</sup> or DCG <sup>f</sup>	Upstream		Downstream	
			Minimum <sup>g</sup>	Maximum <sup>g</sup>	Minimum	Maximum
Aluminum	mg/L	0.05-0.2 <sup>h</sup>	.31	0.65	ND	.47
Ammonia	mg/L	NA <sup>i,j</sup>	ND	0.16	ND	0.55
Cadmium	mg/L	0.005 <sup>d</sup>	ND <sup>k</sup>	ND	ND	ND
Chemical oxygen demand	mg/L	NA	ND	ND	ND	ND
Chloride	mg/L	250 <sup>h</sup>	5	11	5	11
Chromium	mg/L	0.1 <sup>d</sup>	ND	ND	ND	ND
Copper	mg/L	1.3 <sup>l</sup>	ND	0.02	ND	.01
Dissolved oxygen	mg/L	>5.0 <sup>m</sup>	6.7	10.8	6.0	9.4
Fecal coliform	Colonies per 100 ml	1,000 <sup>m</sup>	79	3,200	5	700
Gross alpha radioactivity	pCi/L	15 <sup>d</sup>	<DL <sup>n</sup>	0.586	<DL	0.325
Lead	mg/L	0.015 <sup>l</sup>	ND	ND	ND	ND
Mercury	mg/L	0.002 <sup>d,e</sup>	ND	.0006	ND	.0015
Nickel	mg/L	0.1 <sup>d</sup>	ND	ND	ND	ND
Nitrite/Nitrate (as nitrogen)	mg/L	10 <sup>d</sup>	0.27	0.45	0.27	0.47
Nonvolatile (dissolved) beta radioactivity	pCi/L	50 <sup>d</sup>	5.58E-10	1.2E-08	5.1E-10	3.4E-09
pH	pH units	6.5-8.5 <sup>h</sup>	6.0	7.0	6.3	7.1
Phosphate	mg/L	NA	ND	ND	ND	ND
Sulfate	mg/L	250 <sup>h</sup>	4	11	5	11
Suspended solids	mg/L	NA	3	16	5	27
Temperature	°F	90 <sup>p</sup>	46	76	47	79
Total dissolved solids	mg/L	500 <sup>h</sup>	48	91	52	89
Tritium	pCi/L	20,000 <sup>d,e</sup>	-7.1E-08 <sup>o</sup>	1E-06	4.2E-07	2.4E-06
Zinc	mg/L	5 <sup>h</sup>	ND	0.59	ND	.043

- a. Source: Arnett (1996).
- b. Parameters are those DOE routinely measures as a regulatory requirement or as part of ongoing monitoring programs.
- c. mg/L = milligrams per liter, a measure of concentration equivalent to the weight/volume ratio.  
pCi/L = picocuries per liter, a picocurie is a unit of radioactivity; one trillionth of a curie.
- d. Maximum Contaminant Level (MCL), EPA National Primary Drinking Water Standards (40 CFR Part 141).
- e. Maximum Contaminant Level (MCL): SCDHEC (1976).
- f. DOE Derived Concentration Guides (DCGs) for water (DOE Order 5400.5, "Radiation Protection for the Public and the Environment"). DCG values are based on committed effective dose of 100 millirem per year for consistency with drinking water MCL of 4 millirem per year.
- g. Minimum concentrations of samples. The maximum listed concentration is the highest single result found during one sampling event.
- h. Secondary Maximum Contaminant Level (SMCL). EPA National Secondary Drinking Water Regulations (40 CFR Part 143).
- i. NA = none applicable.
- j. Dependent upon pH and temperature.
- k. ND = none detected.
- l. Action level for lead and copper.
- m. WQS = water quality standard. See glossary.
- n. Less than (<) indicates concentration below analytical detection limit (DL).
- o. This value is an anomaly of sampling technique.
- p. Shall not exceed weekly average of 90°F after mixing nor rise more than 5°F in 1 week unless appropriate temperature criterion mixing zone has been established.

Table 3-6. Water quality in SRS streams and Par Pond.<sup>a</sup>

		Temperature (°F)	pH	Dissolved oxygen (mg/L)	Specific conductance (µmhos/cm)	Turbidity (NTU)	Total suspended solids (mg/L)
Upper Three Runs at Road A <sup>b</sup>	Mean	62	NA	8.36	24.5	5.24	10.2
	Range	45 - 90	4.7 - 8.0	4.9 - 12	3.0 - 41	1.0 - 22	20 - 97
Pen Branch and Indian Grave Branch <sup>b</sup>	Mean	72	NA	8.5	69	6.6	7.7
	Range	40 - 133	5.7 - 7.9	4.2 - 11	13 - 171	1.1 - 54.1	2.0 - 42
Lower Three Runs at Patterson Mill <sup>b</sup>	Mean	64	NA	8.0	75	2.8	4.9
	Range	46 - 84	5.9 - 7.4	5.8 - 11	13 - 140	0.94 - 38	1 - 34
Par Pond Near Cold Dam <sup>c</sup>	Mean	65	6.33	6.01	70	NA	2.02
	Range	47 - 88	5.5 - 7.3	0 - 11.6	46 - 126	NA	0 - 10

NA = Not available.

a. Source: Wike et al. 1994.

b. 1987 - 1991.

c. 1985 - 1991.

**Lower Three Runs.** Lower Three Runs is a large blackwater creek draining about 177 square miles; Par Pond is a 2,500-acre mainstream impoundment on this stream (described in the next section). From the Par Pond Dam, Lower Three Runs flows about 15 miles before it enters the Savannah River (Wike et al. 1994). Lower Three Runs received heated effluent from R-Reactor through Joyce Branch from 1953 to 1958. The construction of the Par Pond Dam in 1958 modified flows in the stream. Effluents from R- and P-Reactors flowed to the Par Pond system and, therefore, affected Lower Three Runs until DOE shut the reactors down in 1963 and 1988, respectively. Historically, SRS operations caused large discharge fluctuations just downstream of the Par Pond dam, but groundwater and tributary inputs were sufficient to dampen these fluctuations farther downstream (Wike et al. 1994). High flows also occurred during the drawdown of Par Pond in 1991. Based on 1996 water year data, the mean flow in Lower Three Runs below Par Pond was 28 cubic feet per second with the highest and lowest daily mean discharges being 82 and 6.4 cubic feet per second, respectively (Cooney 1996). Flows are seasonal, and the winter and spring months have the highest average flow. Table 3-6 lists water quality information for Lower Three Runs.

**Par Pond.** In 1958, DOE constructed Par Pond, a 2,500-acre reservoir, by building an earthen dam across the upper reaches of Lower Three Runs (Wike et al. 1994). The lake has an average depth of 59 feet (Du Pont 1987). At full pool, the reservoir storage volume is approximately 52,800 acre-feet.

Par Pond was a cooling water reservoir for P- and R- Reactors until 1964, when DOE suspended R-Reactor operations (Wilde 1985). It continued to receive heated cooling water until 1988 when DOE suspended P-Reactor operations (Paller and Wike 1996). During reactor operations, recirculating water flowed through the reactor heat exchangers, where it reached temperatures of 150 to 165°F, and discharged through a series of pre-cooler ponds and canals. Water lost from the Par Pond system due to evaporation and seepage was replaced by makeup water pumped from the Savannah River. Par Pond operated as a closed-loop system with the exception of the additions of makeup water and the overflow and seepage to Lower Three Runs at the dam.

During a routine inspection of the Par Pond dam in March 1991, a small depression was discovered in the downstream slope of the earthen dam. DOE ordered a structural investigation

into the cause of the depression and simultaneously initiated a precautionary drawdown of Par Pond (DOE 1995a). From June through September of 1991, Par Pond was lowered about 19 feet, from about 200 to 181 feet (mean sea level) elevation. The drawdown reduced the volume of the reservoir by one-third and exposed about 1,340 acres of lakebed (DOE 1995a).

Par Pond remained lowered at two-thirds of its original volume for more than three years while the dam was being repaired. Repairs included grouting of voids around the outlet conduit, the addition of an energy dissipation structure, and construction of a downstream berm and filter system at the toe of the dam (Marcy et al. 1994). Based on these planned structural improvements to the dam, a Probabilistic Risk Assessment (PRA) was conducted (Olson 1993). The PRA determined that once the permanent repairs had been completed, the probability of a loss of human life due to the failure of the structure ( $2.0 \times 10^{-7}$ ) would be less than the DOE guideline ( $4.0 \times 10^{-7}$ ).

In 1996, DOE stopped pumping river water into Par Pond to allow water levels to fluctuate naturally between 195 and 200 feet. Since then, inflows from the watershed and groundwater have maintained Par Pond level at 199 to 200 feet. The *Final Environmental Impact Statement, Shutdown of the River Water System at the Savannah River Site* (DOE 1997) discusses the results of a water balance study.

Releases from R-Reactor (process leaks, purges, and makeup cooling water) contaminated Par Pond with low levels of radioactive materials, primarily Cesium-137. Releases (except tritium) stopped after the shutdown of R-Reactor in 1964. Most of the Cesium-137 in Par Pond lies in the upper 1 foot of fine sediments, primarily in the area of the original stream corridor. An estimated 43 curies of Cesium-137 remain (DOE 1997).

In the 1960s researchers found elevated levels of mercury in Par Pond bottom sediments. In the early 1970s, an estimated 40 pounds of mer-

cury were in Par Pond water, sediments, and biota (Newman and Messier 1994), approximately half of which came from Savannah River water and half from natural sources (i.e., soils inundated when the reservoir was filled). The sources of mercury in the river water were industrial and manufacturing operations upstream of the SRS that discharged wastes to the river. With the implementation of the Clean Water Act and NPDES regulations in the mid-1970s, these industries dramatically reduced the levels of pollutants in their permitted discharges. Levels of mercury entering SRS water bodies with river water showed a corresponding decline (Newman and Messier 1994). Recent surveys of Par Pond sediments (Koch, Martin, and Friday 1996) found no elevated concentrations of mercury. Table 3-6 lists water quality parameters near the Par Pond Cold Dam and reflect conditions since DOE stopped reactor operations.

*The "Pre-cooler" Ponds: Ponds 2, 5, and C.* DOE built Pond C at the same time it built Par Pond (1957-1958) to pre-cool heated effluent from P-Reactor before it entered Par Pond. Ponds 2 and 5 were added in 1961 to enhance Par Pond's efficiency as a cooling reservoir. These small impoundments and their connecting canals dissipated about 86 percent of the heat in the P-Reactor effluent by the time it entered Par Pond (Wilde 1985). When P-Reactor was operating, its thermal effluents caused surface temperatures in the immediate discharge area of Par Pond (the "bubble up") to be approximately 9°F higher than those in control areas in the North and South Arms of the reservoir (Wilde and Tilly 1985).

Since DOE shut down P-Reactor in 1988, the pre-cooler ponds have received no heated effluents. Inputs from the River Water System stopped in early 1996 (Cooney et al. 1996). Pond 2, which has an area of about 17 acres, appears to be relatively shallow, but details about its basin morphometry are not readily available. Pond 5, which is actually two ponds connected by a narrow dredged channel, has an area of about 41 acres. Pond C has an area of 165 acres, a mean depth of 13 feet, a maximum



depth of 36 feet, and a shoreline length of 4.7 miles (Wilde and Tilly 1985). Water in Pond C flows to Par Pond through a culvert in the Hot Dam.

### 3.3.2.2 Groundwater

Industrial solvents, metals, tritium, and other chemicals used or generated on the SRS have contaminated the shallow aquifers beneath 5 to 10 percent of the Site (Arnett, Karapatalis, and Mamatey 1993). In general, DOE does not use these aquifers for SRS operations or drinking water, although there are a few low-yield wells in the Gordon Aquifer. The shallow aquifer units discharge to SRS streams and eventually to the Savannah River (Arnett and Mamatey 1996). Figure 3-10 shows the locations of major sources and potential sources of groundwater contamination at SRS.

F- and H- Areas, more than 1 mile southwest of the preferred APT site, are the closest sources of contaminated groundwater. As discussed in Section 3.3.1, the general direction of groundwater flow from the northern portions of F- and H-Areas is toward Upper Three Runs (toward the alternate site) in the water table aquifer and to the northwest in the Gordon Aquifer, and toward the Savannah River in the Crouch Branch and McQueen Branch Aquifers (Aadland, Gellici, and Thayer 1995).

The groundwater at the APT site has no detectable or only minor concentrations of organic compounds; inorganic constituents (metals, chlorine, fluorine, nitrogen, sulfate, etc.) occur within the range expected for regional aquifers. Radiological analysis of groundwater from the water table (Upper Three Runs) aquifer showed that gross alpha, nonvolatile beta, total radium, and tritium are present in some locations beneath the preferred APT site and are slightly above the respective drinking water standards.

In January 1991 a groundwater quality study (WSRC 1991a) at the preferred APT site collected samples from 34 sampling wells. Twenty samples were from the Upper Three Runs Aquifer

(i.e., the water table aquifer), 10 were from the underlying Gordon Aquifer, three were from the deeper Crouch Branch Aquifer, and one was from the deepest McQueen Branch Aquifer. The study also recorded field data (pH, water temperature, etc.) during the groundwater sample collection (Table 3-7 lists field sampling results).

Laboratory analyses of the groundwater samples characterized aquifer geochemistry and screened the groundwater for any potential contamination. The analyses tested for the following chemical parameters:

- Metals (arsenic, barium, cadmium, calcium, chromium, copper, iron, lead, magnesium, mercury, nickel, selenium, silver, sodium)
- Inorganic constituents (chlorine, fluorine, ammonia, nitrate, sulfate, total phosphate)
- Twenty-eight volatile organic constituents
- Phenol (a semivolatile organic)
- Six selected pesticides and herbicides
- Total organic Carbon content (indicator parameter for a general group of organic constituents) Total organic halogens content (indicator parameter for a general group of organic constituents)
- Radiological testing for gross alpha, nonvolatile beta, total radium, and tritium content

No pesticides or herbicides were detected in the 34 groundwater samples. This was similar to the other organic constituents, of which only phenol, total organic Carbon, and total organic halogens had detectable concentrations. The highest concentrations of total organic halogens were 121 micrograms per liter in the Upper Three Runs Aquifer, 238 micrograms per liter in the Gordon Aquifer, 24.5 micrograms per liter in the Crouch Branch aquifer, and none in the

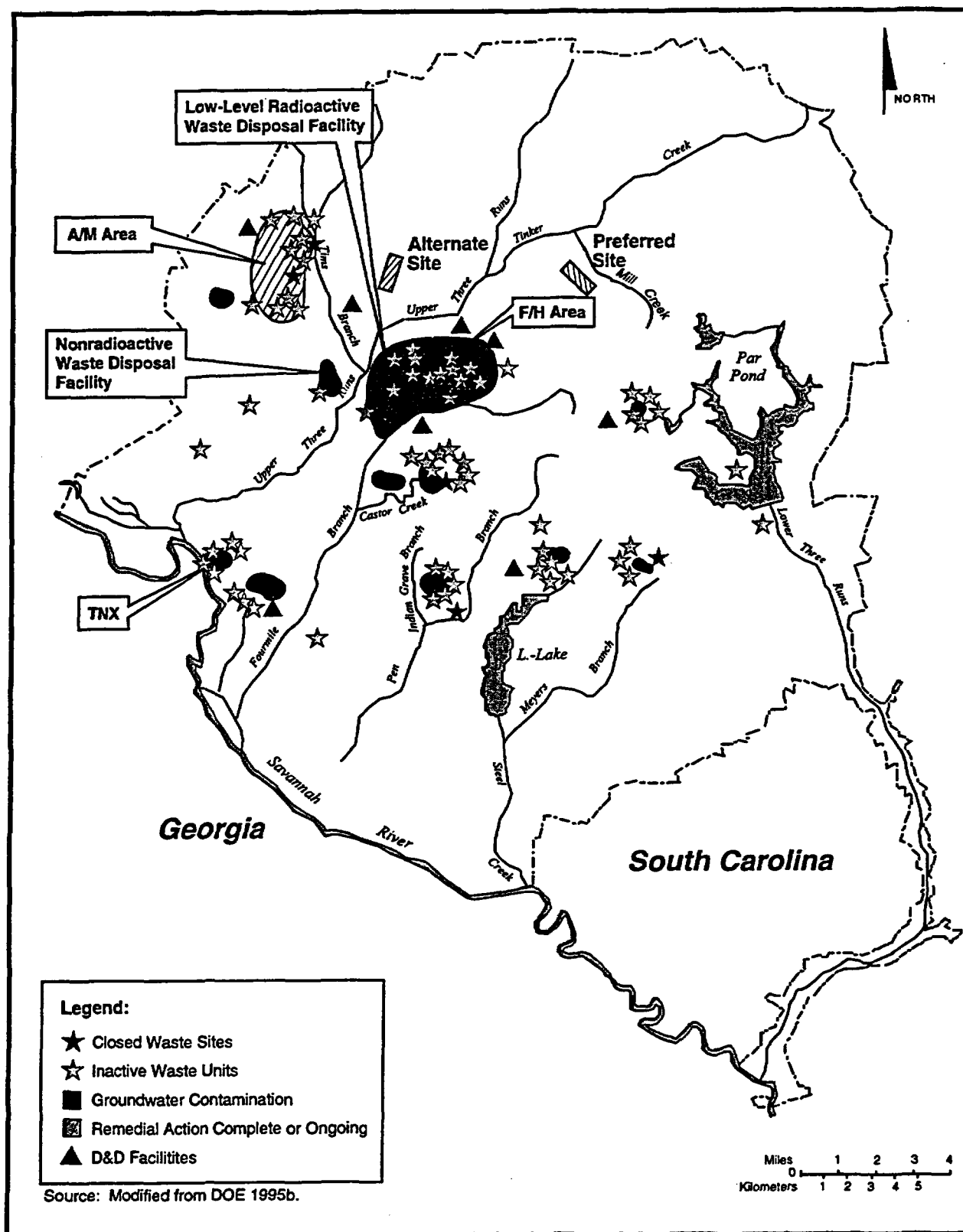

Figure 3-10. Location of groundwater contamination and waste sites at the Savannah River Site.

**Table 3-7. Summary of radiological groundwater quality and field sampling results beneath the preferred APT Site.<sup>a</sup>**

Aquifer	Groundwater parameter	Unit	Lowest analytical detection level	Number of samples		Range of detected values		Drinking water standard <sup>b</sup> (status)
				Collected	Above detection level	Low	High	
Upper Three Runs	Nonvolatile beta	pCi/l	4	20	10	12	97 <sup>c</sup>	50 (interim final)
	Total radium	pCi/l	1	20	16	1.1	20 <sup>c</sup>	20 (proposed)
	Tritium	pCi/ml	1	20	16	1.4	20 <sup>c</sup>	20 (final)
	pH	NA	NA	19	NA	5.39	10.6	NA
	Water temperature	Fahrenheit	NA	19	NA	54.5	65.3	NA
	Gross alpha	pCi/l	2.5	10	6	2.5	10	15 (final)
Gordon	Nonvolatile beta	pCi/l	4	10	9	4.8	30	50 (interim final)
	Total radium	pCi/l	1	10	8	1.1	6.3	20 (proposed)
	Tritium	pCi/ml	1	10	2	2.3	4.3	20 (final)
	pH	NA	NA	9	NA	5.49	12.09	NA
	Water temperature	Fahrenheit	NA	9	NA	61	64.6	NA
	Gross alpha	pCi/l	3	3	0	NA	NA	15 (final)
Crouch Branch	Nonvolatile beta	pCi/l	4	3	1	5.5	5.5	50 (interim final)
	Total radium	pCi/l	1	3	3	1.1	2	20 (proposed)
	Tritium	pCi/ml	1	3	0	NA	NA	20 (final)
	pH	NA	NA	1	NA	5.50	5.50	NA
	Water temperature	Fahrenheit	NA	2	NA	65.3	65.3	NA
	Gross alpha	pCi/l	4	1	0	NA	NA	15 (final)
McQueen Branch	Nonvolatile beta	pCi/l		1	1	5.6	5.6	50 (interim final)
	Total radium	pCi/l		1	1	4.6	4.6	20 (proposed)
	Tritium	pCi/ml	1	1	0	NA	NA	20 (final)
	pH	NA	NA	1	NA	5.85	5.85	NA
	Water temperature	Fahrenheit	NA	1	NA	67.3	67.3	NA
	Gross alpha	pCi/l	2	20	10	6.9	72 <sup>c</sup>	15 (final)

a. Source of information for table compiled from WSRC 1991b.  
 b. Source of drinking water standards is WSRC 1996c.  
 c. Indicates values equal to or higher than the drinking water standard.  
 NA = Not applicable.

deepest McQueen Branch Aquifer (WSRC 1991a).

Detected concentrations of total organic carbon and phenols were only marginally above the detection level of 1 milligram per liter and 5 micrograms per liter, respectively. Phenol was detected in one sample from the Upper Three Runs Aquifer at a concentration of 5.18 micrograms per liter. The highest detected concentrations of total organic carbon were 4.82 and 5.56 micrograms per liter in the Upper Three Runs and Gordon Aquifers, respectively. Total organic carbon is a gross indicator that can reflect compounds such as natural organic acids and organic matter. The absence of volatile organic constituents (typical of solvents used at the SRS) in the groundwater indicates that industrial activities have not affected the groundwater (WSRC 1991a).

Air and water measurements for radioactivity often include measurements for gross alpha, nonvolatile beta, and total radium content. *Gross alpha* refers to the total alpha emission rate of the sample and is an indicator of the radionuclides in the sample that decay by alpha emission. Similarly, *nonvolatile beta* refers to the beta emission rate but is limited to constituents that are not gaseous (i.e., not capable of being volatilized). *Total radium* refers to measurements of the radium content in the sample; because most radium isotopes also emit alpha particles, the gross alpha measurement includes a contribution from radium isotopes. Measurements of gross alpha, nonvolatile beta, and total radium content cannot be used by themselves to calculate radiation dose, because the specific radionuclides are not known. However, using these measurements to develop trends over time can help assess small increases in radioactive material in the environment.

In general, inorganic parameters were within the ranges expected for regional aquifers, indicating that agricultural and other human impacts to groundwater have been negligible (WSRC 1991a). However, one groundwater sample from the water table aquifer showed concentrations of lead (126 micrograms per liter) and

mercury (2.39 micrograms per liter) that exceeded the drinking water standards (50 micrograms per liter for lead and 2 micrograms per liter for mercury). These exceedances were caused by the assimilation of components of the drilling mud (sodium bentonite) that were still being desorbed by sediments around the monitoring well, indicated by the higher than normal sodium and calcium concentrations in the same well (WSRC 1991a).

Radiological analyses of groundwater from the water table aquifer (Upper Three Runs Aquifer) showed that gross alpha, nonvolatile beta, total radium, and tritium are present in some locations under the preferred APT site at or slightly above the drinking water standard. The analyses detected total radium and tritium only once at a concentration equal to their respective drinking water standards. All other groundwater samples had either nondetectable levels of total radium and tritium or concentrations that were less than the drinking water standard. Analyses of the deeper aquifers below the preferred site revealed no other radiological constituents in excess of the drinking water standards (WSRC 1991a). Table 3-7 summarizes the radiological sampling results for each aquifer beneath the preferred site.

DOE has not characterized the groundwater quality at the alternate APT site for geochemical properties or contamination. DOE would complete characterization studies if the alternate site is selected.

### 3.3.3 CLIMATE

The climate at the SRS is relatively mild, with an average frost-free season of approximately 246 days. The average annual rainfall, about 48 inches, is fairly evenly distributed throughout the year. There is no strong prevailing wind direction; however, there is a relatively high frequency of east-to-northeast winds during the summer and fall and of south-to-northwest winds during the late fall, winter, and spring (Hunter 1990). The average wind speed is 8.5 miles per hour. With the exception of the

Savannah River, no topographic features significantly influence the general climate.

DOE uses meteorological data as input for atmospheric transport and dose models that estimate the dispersion of radionuclides and emissions from various SRS facilities. Analyses use a 5-year average data base rather than actual annual data because of the difficulty of compiling, entering, and validating the data in time for use in current-year calculations, and because there is little year-to-year variation in the SRS meteorology. These measurements include dispersion conditions observed during the 5-year period, ranging from *unstable* (considerable turbulence, which leads to rapid dispersion), to *very stable* (very little turbulence, which produces a narrow, undispersed plume). In general, as the atmosphere becomes more unstable, atmospheric dispersion of airborne pollutants increases and ground-level concentrations decrease. The meteorology at the SRS is unstable about 56 percent of the time.

The average annual temperature at the SRS is 64°F. The average relative humidity is greatest during the summer and lowest during the winter and ranges from 90 percent in the early morning to about 43 percent in the afternoon (Hunter 1990). During the summer months, the maximum and minimum daily average humidities range from 98 to 41 percent, respectively. During the winter, the maximum and minimum daily average humidity ranges from 89 to 36 percent, respectively.

*Savannah River Site Affected Environment* (Shedrow 1993) contains more detailed information on the SRS climate, including severe weather patterns.

### 3.3.4 AIR RESOURCES

#### 3.3.4.1 Radiological Air Quality

In the SRS region, airborne radionuclides originate from natural sources (i.e., terrestrial and cosmic), worldwide fallout, and nuclear facility operations. DOE maintains a network of air

monitoring stations on and around the Site to determine concentrations of radioactive particulates and aerosols in the air (Arnett and Mamatey 1996).

Tritium is the only radionuclide of SRS origin detected routinely in offsite air samples. All radiological releases are within regulatory limits.

Table 3-8 lists average and maximum atmospheric concentrations of radioactivity at the SRS boundary, at a 25-mile radius, and at background monitoring locations (100-mile radius) during 1995. Tritium is the only radionuclide of SRS origin detected routinely in offsite air samples above background concentrations (Arnett and Mamatey 1996). Most of the radionuclides cannot be measured in the environment around the Site due to their extremely low concentrations. However, DOE used SRS-specific computer models such as MAXIGASP and POPGASP to calculate radiological doses for members of the public for the 1995 releases based on the amount released and the estimated concentrations in the environment.

#### 3.3.4.2 Nonradiological Air Quality

The SRS is in a region that is designated an *attainment area* because it complies with National Ambient Air Quality Standards (NAAQS) for criteria pollutants. The closest nonattainment area (an area that does not meet NAAQ standards) is the Atlanta, Georgia, air quality region, about 145 miles to the west. Attainment areas do not have restrictions on growth that nonattainment areas might have. Prevention of Significant Deterioration (PSD) regulations apply to new or modified sources of air pollution if a net increase in emissions from the new or modified source exceeds the PSD maximum allowable increments (40 CFR 52.21).

DOE models the atmospheric dispersion of both maximum potential and actual emissions of regulated pollutants using the U.S. Environmental Protection Agency (EPA) *Industrial Source*

**Table 3-8. Radioactivity in air at the SRS boundary, at the 25-mile radius, and at the 100-mile radius during 1995 (picocuries per cubic meter).<sup>a</sup>**

Location	Gross alpha	Nonvolatile beta	Tritium
Site boundary			
Average	0.0014	0.018	16
Maximum	0.0043	0.035	96
25-mile radius			
Average	0.0014	0.018	10
Maximum	0.0036	0.032	42
Background (100-mile radius)			
Average	0.0016	0.018	10
Maximum	0.0041	0.032	20

a. Sources: Arnett and Mamatey (1996); Arnett (1996).

DOE measures nonradiological air emissions from SRS facilities at their points of discharge by direct measurement, sample extraction and measurement, or process knowledge. Using monitoring data and meteorological information, DOE estimates the concentration of certain pollutants at the Site boundary. The Site is in compliance with National Ambient Air Quality Standards.

The Environmental Protection Agency recently approved revisions to the national ambient air quality standards for ozone and particulate matter that will become effective on September 16, 1997 (62 FR 138). For ozone, the current 1-hour primary standard will be replaced with a more stringent 8-hour standard with a limit of 0.08 part per million. In addition, the revision adds strict monitoring requirements for particulate matter with a diameter less than or equal to 2.5 micrometer. According to the Clean Air Act, the next step for EPA is to complete a periodic review of the new standards -- during the next 5 years for particulate matter and during the next 3 years for ozone. In that time, EPA will determine areas that are in nonattainment with the new standards. These areas will have 3 years to develop pollution control plans and submit them to the EPA, showing how they will meet the new standards. Then the areas will have 10 years to reach attainment with the revised standards. In the SRS region, Augusta-Richmond County, Georgia, is likely to fail the new ozone standards; it is uncertain if the county would exceed the new particulate matter standards.

*Complex Short Term Model* (EPA 1992). The major categories of monitored emissions include sulfur dioxide (SO<sub>2</sub>), Carbon monoxide (CO), oxides of nitrogen (NO<sub>x</sub>), particulate matter smaller than 10 microns (PM<sub>10</sub>), volatile organic compounds (VOCs) (ozone precursors), and toxic air pollutants. SRS facilities that produce such emissions include those associated with diesel-engine-powered equipment, package steam boilers, the Defense Waste Processing Facility, the in-tank precipitation process, groundwater air strippers, and other process facilities. In addition, the periodic prescribed burning of forested areas across the Site contributes to the release of several criteria pollutants (SO<sub>2</sub>, CO, NO<sub>x</sub>, PM<sub>10</sub>, ozone (O<sub>3</sub>), lead, and gaseous fluorides) (Arnett and Mamatey 1996). Some 14,000 to 18,000 acres are prescribed burned annually, primarily in the spring of the year (Myers 1997). Table 3-9 lists estimated ambient concentrations of these regulated air pollutants.

The South Carolina Department of Health and Environmental Control has the authority to regulate air quality over the SRS and determine compliance based on pollutant emission rates and estimates of concentrations at the Site boundary based on modeling. The SRS is in compliance with SCDHEC Regulation 61-62.5, Standard 2 (Ambient Air Quality Standards) and Standard 8 (Toxic Air Pollutants). Table 3-9 lists limits from these standards. Standard 2 sets

**Table 3-9.** Estimated ambient concentration contributions of air pollutants from existing SRS sources and sources planned for construction or operation through 1995 (micrograms per cubic meter of air).<sup>a,b</sup>

Pollutant <sup>c</sup>	Averaging time	SRS maximum potential concentration ( $\mu\text{g}/\text{m}^3$ ) <sup>d</sup>	Concentrations based on actual emissions ( $\mu\text{g}/\text{m}^3$ ) <sup>e</sup>	Most stringent AAQS <sup>f</sup> (Federal or state) ( $\mu\text{g}/\text{m}^3$ )	Maximum potential concentration as a percent of AAQS <sup>g</sup>
SO <sub>2</sub>	3 hours	1210	634	1,300 <sup>h,i</sup>	93
	24 hours	356	185	365 <sup>h,i</sup>	98
	Annual	18	9.5.5	80 <sup>h</sup>	23
NO <sub>2</sub> (as NO <sub>x</sub> )	Annual	30	3.8	100 <sup>h</sup>	30
CO	1 hour	3553	180	40,000 <sup>h</sup>	9
	8 hours	819	23	10,000 <sup>h</sup>	8
Gaseous fluorides (as HF)	12 hours	241.2	0.62	3.7 <sup>g</sup>	65
	24 hours	0.60	0.314	2.9 <sup>g</sup>	41
	1 week	0.11	0.170.03	1.6 <sup>g</sup>	38
	1 month			0.8 <sup>g</sup>	14
PM <sub>10</sub>	24 hours	93	56	150 <sup>h</sup>	62
	Annual	9.1	2.7	50 <sup>h</sup>	18
O <sub>3</sub>	1 hour	NA <sup>j</sup>	NA	235 <sup>h</sup>	NA
TSP	Annual geometric mean	20	11	75 <sup>g</sup>	27
Lead	Calendar quarter mean	0.002	0.0003	1.5 <sup>g</sup>	0.13

a. Source: Hunter and Stewart (1994).

b. The concentrations are the maximum values at the SRS boundary.

c. SO<sub>2</sub> = sulfur dioxide; NO<sub>x</sub> = nitrogen oxides; CO = carbon monoxide; HF = hydrogen fluoride; PM<sub>10</sub> = particulate matter  $\leq 10$  microns in diameter; O<sub>3</sub> = ozone; TSP = total suspended particulates.

d. Based on maximum potential emissions from all SRS sources permitted through July 1993; listed values are from calculations reported to SCDHEC in September 1993.

e. Based on actual emissions from SRS sources plus maximum potential emission for sources permitted for construction through December 1992.

f. AAQS = Ambient Air Quality Standard.

g. Source: SCDHEC (1976).

h. Source: 40 CFR Part 50.

i. Concentration not to be exceeded more than once a year.

j. NA = not available.

limits for the six NAAQ criteria pollutants and two additional pollutants, gaseous fluorides and total suspended particulates (TSP). Standard 8 regulates the emission of 257 toxic air pollutants. DOE has identified emission sources for 139 of these substances.

### 3.3.5 HISTORIC AND ARCHAEOLOGICAL RESOURCES

Field studies conducted since the 1970s by the South Carolina Institute of Archaeology and Anthropology of the University of South Caro-

lina, under contract to DOE and in consultation with the South Carolina State Historic Preservation Officer (SHPO), have provided information about the distribution and content of archaeological and historic sites on the SRS. By the end of October 1996, these studies had examined about 70 percent of the Site, and had identified 1,200 archaeological (historic and prehistoric) sites. Of these sites, 53 are eligible for the National Register of Historic Places. No SRS facilities have been nominated for the National Register, and there are no plans for nominations at this time (Brooks 1996). Archaeologists have divided the SRS into three zones related to their potential for containing sites with multiple archaeological components or dense or diverse artifacts, and their potential for nomination to the National Register of Historic Places (DOE 1995b).

- Zone 1 is the zone of the highest archaeological site density, with a high probability of encountering large archaeological sites with dense and diverse artifacts, and a high potential for nomination to the National Register of Historic Places.
- Zone 2 includes areas of moderate archaeological site density. Activities in this zone have a moderate probability of encountering large sites with more than three prehistoric components or that would be eligible for nomination to the National Register of Historic Places.
- Zone 3 includes areas of low archaeological site density. Activities in this zone have a low probability of encountering archaeological sites and virtually no chance of encountering large sites with more than three prehistoric components; the need for site preservation is low. Some exceptions to this definition have been discovered in Zone 3; some sites in the zone could be considered eligible for nomination to the National Register of Historic Places.

The preferred APT site falls in archaeology zone 3 and consists of a large portion of a tract

evaluated by the Savannah River Archaeological Research Program (SRARP) in 1986 for a new waste storage/disposal facility (Brooks et al. 1986). No archaeological sites were located at the time. In June 1996, the SRARP conducted additional surveys for the APT site areas that were not part of the 1986 work and to further evaluate 20th-century homesites. The most recent survey resulted in the discovery of seven archaeological sites: one site consists of a prehistoric lithic scatter; the remaining sites are late 19th- and 20th-century homesites.

The alternate site includes archaeology zones 1, 2, and 3, although more than half lies in Zone 3. This site has not had a systematic survey and evaluation, but because it is in an area with low potential for significant prehistoric sites, the Savannah River Archaeology Research Program does not expect to find prehistoric sites that would be eligible for nomination to the National Historic Register. There is greater potential for sites of the historic period (Sassaman 1997).

In 1991 DOE solicited the concerns of Native Americans about religious rights in the Central Savannah River Valley. During this study, three Native American groups -- the Yuchi Tribal Organization, the National Council of Muskogee Creek, and the Indian People's Muskogee Tribal Town Confederacy -- expressed general concerns about SRS and the Central Savannah River Area, but did not identify specific sites as having religious significance. The Yuchi Tribal Organization and the National Council of Muskogee Creek are interested in plant species traditionally used in tribal ceremonies, such as redroot, button snakeroot, and American ginseng (NUS 1991a). Redroot and button snakeroot occur on the SRS (Batson, Angerman, and Jones 1985).

### 3.3.6 SITE LAND USE AND INFRA-STRUCTURE

SRS occupies approximately 198,000 acres in a generally rural area in western South Carolina. Administrative, production, and support facilities occupy 5 percent (approximately 17,000



acres) of the total SRS area. The remaining land, approximately 181,000 acres is forest land and swamp managed by the U.S. Forest Service (under an interagency agreement with DOE). Approximately 14,000 acres of SRS have been set aside exclusively for nondestructive environmental research (DOE 1993) in accordance with SRS's designation as a National Environmental Research Park. Research in the set-aside areas is coordinated by the University of Georgia's Savannah River Ecology Laboratory.

### Roads and Rail

The SRS transportation infrastructure consists of more than 143 miles of primary roads, 1,200 miles of unpaved roads, and 64 miles of railroad track. These roads and railroads provide connections between the SRS facilities and links to offsite transportation (see Figure 3-11).

In general, heavy traffic on roads occurs in the early morning and late afternoon when workers commute to and from the SRS. The *Savannah River Waste Management Final Environmental Impact Statement* (DOE 1995b) summarizes baseline traffic flows for primary SRS roads. During working hours official vehicles, solid waste haulers, and logging trucks constitute most of the traffic. The *Environmental Assessment for the Construction and Operation of the Three Rivers Solid Waste Authority Regional Waste Management Center at the Savannah River Site* (DOE 1995c) describes the projected traffic volume associated with solid waste landfill operations.

The SRS rail yard, an eight-track facility east of P-Reactor, sorts and redirects onsite rail cars. Deliveries of shipments to the SRS can occur at rail stations in the former towns of Ellenton and Dunbarton. From these stations, an SRS engine moves rail cars to the appropriate facility. Historically, the Ellenton station, which is on the main Augusta-Yemassee line, received coal for the D-Area Powerhouse, while the Dunbarton station received other rail shipments and coal for the smaller SRS Powerhouses. However, coal is now delivered to the Site by truck, not by rail. As a result, the SRS railroad

system receives sporadic limited use (McInain 1997).

Current railroad use consists of shipments of radioactive casks of spent nuclear fuel from off the Site or between the reactor areas and separations facilities. In addition, shipments of radioactive waste destined for treatment or disposal at the SRS arrive on the Site by rail.

### Utilities and Resource Usage

**Electrical Power Distribution System.** The South Carolina Electric and Gas Company (SCE&G) supplies SRS electric power needs via one 160-kilovolt and two 115-kilovolt transmission lines with available power of about 390 megawatts. Current Site demand is about 70 megawatts. Figure 3-12 shows the SRS electric distribution system (Shedrow 1997). The D-Area Powerhouse, which once provided a portion of the Site's electricity needs, is now under lease to SCE&G, which in turn sells electricity to DOE.

SCE&G also provides electric service to more than 446,000 customers in a 15,000-square-mile service area in the central, southern, and southwestern portions of South Carolina; the area extends into 24 of the State's 46 counties. System-wide electric sales grew by 3.4 percent in 1990 to 15.4 billion kilowatt-hours. Residential and commercial sales accounted for most of the increase. The electric base grew by 2.6 percent. Over a 4-year period before 1990, total customers and kilowatt-hour sales increased at average annual rates of 2.4 and 3.0 percent, respectively (SCE&G 1995). SCE&G has a combined generating capacity of 4,200 megawatts. The current peak load is 3,700 megawatts; resulting in a reserve capacity of 500 megawatts (White 1997). In addition, SCE&G has the ability to sell power to or purchase power from companies within the region through a common utility practice known as "retail wheeling," when system loads require augmenting or when the system has excess power.

**Steam Distribution System.** Steam generation facilities at the SRS include coal-fired powerhouses at A-, D-, and H-Areas, and two package boilers, which use number 2 fuel oil, in K-Area. At present, steam generation occurs continuously at the A- and D-Area facilities. DOE has privatized the D-Area Powerhouse, which provides most of the steam for the SRS. DOE leases this area to SCE&G, which in turn produces and sells steam to DOE.

**Natural Gas.** The Site does not have natural gas distribution systems.

**Domestic and Process Water Distribution System.** Current groundwater withdrawals at SRS for domestic and process uses total 9 to 12 million gallons per day (Arnett and Mamatey 1996). Domestic water is supplied from groundwater wells in several SRS areas. The main well system supplies water to A-, M-, B-, C-, F, and H- Areas. The outlying areas (P-, L-, TNX) receive water from wells in those areas. Figure 3-13 shows the SRS domestic water system; the average current demand is about 960 gallons per minute; the peak available flow is about 3,450 gallons per minute (Shedrow 1997).

The Primary Sanitary Sewer Collection System at SRS consists of 16.5 miles of force main piping, 1 mile of gravity lines, and 12 pump stations in different areas. Wastewater from this collection system is treated at the Central Sanitary Wastewater Treatment Facility, which discharges to Fourmile Branch. The facility has a treatment capacity of 1.05 million gallons per day and a current average daily flow of 30,000 gallons per day. In addition, there are small satellite wastewater treatment plants in D-, K-, L-, P-, and TNX-Areas (Shedrow 1997). Figure 3-14 shows the SRS wastewater collection system. The total average daily wastewater flows from these facilities (D-, K-, L-, P-, and TNX) to SRS streams and ultimately the Savannah River total 26,500 gallons per day (Shedrow 1997).

**River Water System.** The River Water System (see Figure 2-5) includes three pumphouses, two (1G and 3G) on the Savannah River, and

one (6G) on Par Pond. Pumphouse 5G is also on the Savannah River, but it is a separate piping system that supplies cooling water to the D-Area Powerhouse. Pumphouses 1G and 6G are no longer operating, but DOE has maintained the 1G pumphouse and system. The total design capacity of the 1G and 3G pumphouses is 400,000 gallons per minute. In 1997, DOE installed a 5,000 gallon per minute pump in Pumphouse 3G to save energy and costs. At present, only Pumphouse 3G is in use, withdrawing 5,000 gallons per minute from the Savannah River to supply SRS facilities.

DOE prepared an environmental impact statement that investigated alternatives for placing all or parts of the River Water System in standby [*Final Environmental Impact Statement, Shutdown of the River Water System at the Savannah River Site* (DOE 1997)]. The alternatives included shutting down and deactivating the system with no capability for restart, and placing all or parts of the system in a layup condition to support future missions.

### Waste Generation and Facilities

SRS activities generate several types of wastes: low-level (low and intermediate activity) radioactive waste, liquid high-level radioactive waste, hazardous waste, mixed waste (radioactive and hazardous combined), and transuranic waste. The *Savannah River Site Waste Management Environmental Impact Statement* (DOE 1995b) discusses the waste generation forecast and the current treatment, storage, and disposal of these wastes at the Site. As discussed in Chapter 2, the APT will not generate high-level or transuranic waste. Therefore, this section does not discuss the SRS facilities that handle such wastes.

The following paragraphs discuss SRS waste handling systems. Appendix A contains more details on facility operations.

**Low-Level Radioactive Waste.** Low-level radioactive waste is waste that contains radioactivity and is not classified as high-level waste,

transuranic waste, spent nuclear fuel, or by-product material. DOE packages low-level waste for disposal in the SRS Low-Level Radioactive Waste Disposal Facility, which consists of a series of vaults in E-Area that began receiving such waste in September 1994. The vaults store low-activity, intermediate-activity, intermediate-level nontritium, and intermediate-level tritium wastes.

**Hazardous Waste.** At the SRS, routine facility operations and environmental restoration projects can generate hazardous waste as defined by the Resource Conservation and Recovery Act (RCRA). DOE stores such waste in hazardous waste storage facilities in new buildings in B- and N- Areas before shipping it to permitted treatment, storage, and disposal facilities.

DOE began offsite shipments of hazardous waste to treatment and disposal facilities in 1987. In 1990 the Department imposed a moratorium on shipments of hazardous waste from radiological materials areas or waste that was not proven to be nonradioactive. DOE continues to send hazardous waste that is not subject to the moratorium (e.g., recyclable solvents) off the Site for recycling, treatment, or disposal.

**Mixed Waste.** Mixed waste contains both hazardous waste (as discussed above), and source, special nuclear, or byproduct material (subject to the Atomic Energy Act of 1954). The SRS mixed waste program consists primarily of continuing to store such wastes safely until treatment and disposal facilities are available. The SRS mixed waste storage facilities are in E-, N-, M-, S-, and A- Areas. In addition, DOE built the Consolidated Incineration Facility in H-Area to treat mixed, low-level, and hazardous waste.

**Sanitary Waste.** Sanitary waste is solid waste that is neither hazardous as defined by RCRA, nor radioactive. It consists of salvageable material and materials deposited in municipal sanitary landfills. Sanitary waste streams include such items as paper, glass, discarded office material, and construction debris. At present, DOE trucks sanitary waste off the SRS for dis-

posal at the Beaufort County Landfill. Further, the Department has signed an agreement that would allow the Three Rivers Solid Waste Authority to construct and operate a solid waste landfill on the SRS at the intersection of Highway 125 and SRS Road 2. The Authority has received a solid waste landfill permit from SCDHEC to operate the landfill, which will receive SRS waste and sanitary waste from a number of counties in the area. This landfill will begin accepting waste in mid-1998.

DOE also operates the Burma Road Landfill on the SRS for the disposal of demolition and construction debris. This landfill has a South Carolina Department of Health and Environmental Control permit for the disposal of wastes and uncontaminated soil, rock (stone), concrete rubble, and inert construction debris. DOE estimates that the landfill will reach its permitted capacity by 2008 (DOE 1995c).

### 3.3.7 VISUAL RESOURCES AND NOISE

#### Visual Resources

The dominant aesthetic settings in the SRS vicinity are agricultural land and forest, with limited residential and industrial areas. The SRS is almost completely forested, with only about 5 percent of the total area in industrial use. The industrial areas are primarily in the interior of the Site, away from public access. Because of the distance to the boundary from the industrialized areas, the rolling terrain, normally hazy atmospheric conditions, and heavy vegetation, SRS facilities are not generally visible from roads with public access.

#### Noise

SRS facilities include many noise sources, most of which are in areas that are a considerable distance from the Site boundary and, therefore, result in little or no contribution to offsite sound levels under most conditions. Major SRS noise sources include cooling towers, fans, pumps, compressors, steam vents, paging systems, construction equipment, material handling

## Noise Measurement

### What are sound and noise?

When an object vibrates it possesses energy, some of which transfers to the air, causing the air molecules to vibrate. The disturbance in the air travels to the eardrum, causing it to vibrate at the same frequency. The ear and brain translate the vibration of the eardrum to what we call *sound*. *Noise* is simply unwanted sound.

### How is sound measured?

The human ear responds to sound pressures over an extremely large range of values. The range of sounds people normally experience extends from low to high pressures by a factor of 1 million. Accordingly, scientists have devised a special scale to measure sound. The term *decibel* (abbreviated dB), borrowed from electrical engineering, is the unit commonly used.

Another common sound measurement is the A-weighted sound level, denoted as dBA. The A-weighting accounts for the fact that the human ear responds more effectively to some pitches than to others. Higher pitches receive less weighting than lower ones. Most of the sound levels provided in this EIS are A-weighted; however, some are in decibels due to a lack of information on the frequency spectrum of the sound. The scale to the right provides common references to sound on the A-weighted sound-level scale.

### TYPICAL A-WEIGHTED SOUND LEVELS

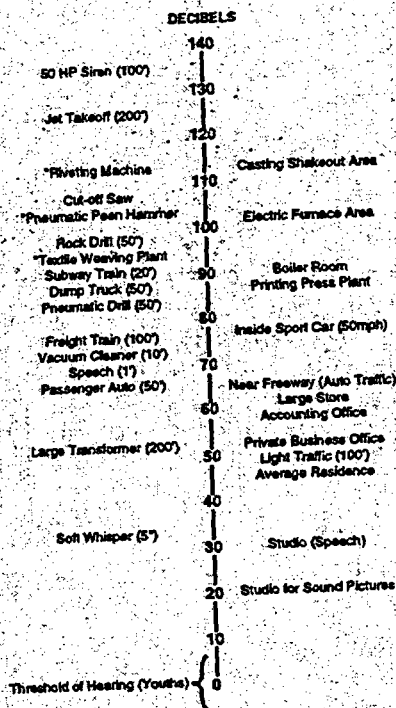

equipment, alarms, and vehicles. Major sources outside the activity areas consist of vehicle and railroad operations, which are also the major sources of noise at offsite areas that can be attributed to SRS activities.

A sound-level study performed in 1989 and 1990 provided background sound-level data for major transportation routes near the SRS and for a limited number of onsite locations. The estimated 24-hour equivalent sound levels at all measurement locations were below the EPA guideline level of 70 dBA, which is required to protect the public from hearing loss. The EPA general guideline for environmental noise protection limits the average day-night sound level to 55 dBA; many SRS areas exceed this level, largely because of insect and wildlife noise. *Air Quality, Cooling Tower, and Noise Impact Analyses in Support of the New Production Reactor Environmental*

*Impact Statement* (NUS 1991b) summarizes the results of this study.

## 3.4 Human and Biological Environment

This section provides information on human health, plants, and animals. The human and biological environment comprises the receptor groups that exposures generated by an accelerator and associated operations would affect.

### 3.4.1 HUMAN HEALTH

The actions described in this EIS have the potential to affect the health of the public and SRS workers. Emissions from the Site can expose both groups to radioactive and nonradioactive materials. In addition, workers are exposed to

occupational hazards similar to the hazards at any industrial work site.

The following paragraphs discuss current releases of radioactive and nonradioactive sources. Historic information establishes a baseline for a comparison to the estimated impacts described in Chapter 4.

### Public Health

**Radiological.** The release of radioactive material to the environment from any nuclear facility is a sensitive issue. Because there are many other sources of radiation in the human environment, evaluations of releases from nuclear facilities must consider all ionizing radiation from which people receive routine exposures.

Public radiation exposure in the SRS region amounts to approximately 360 millirem per year, consisting of natural background radiation from cosmic, terrestrial, and internal body sources along with radiation from medical diagnostic and therapeutic practices; weapons test fallout; consumer and industrial products; and nuclear facilities. Figure 3-15 shows the relative contributions of each type of source to people living near the SRS. All radiation doses mentioned in this EIS are effective dose equivalents; internal exposures are reported as committed effective dose equivalents.

DOE uses the dose-to-risk conversion factors recommended by the National Council on Radiation Protection and Measurements (NCRP) to estimate the number of latent cancer fatalities that could result from radiation exposure. No data indicate that small radiation doses cause cancer; to be conservative, however, the NCRP assumes that any amount of radiation carries some risk of inducing cancer. DOE has adopted the NCRP factors of 0.0005 latent cancer fatality for each person-rem of radiation dose to the general public and 0.0004 latent cancer fatality for each person-rem of radiation dose to radiation workers (NCRP 1993).

Releases of radioactive material to the environment from the SRS account for less than 0.1 percent of the total annual average environmental radiation dose to individuals within 50 miles of the Site. Natural background radiation contributes about 82 percent of the annual dose of 360 millirem.

Nuclear facilities within 50 miles of the SRS include a low-level waste burial site operated by Chem-Nuclear Systems, Inc., near the eastern Site boundary, and the Georgia Power Company Vogtle Electric Generating Plant, directly across the Savannah River from the Site. In addition, Carolina Metals, Inc., which is northwest of Boiling Springs in Barnwell County, processes depleted Uranium. Based on DOE measurements, the Chem-Nuclear and Carolina Metals facilities do not influence radioactivity levels in the air, precipitation, groundwater, soil, vegetation, or external radiation (SCDHEC 1995). In 1992, releases from Plant Vogtle produced an annual dose to the maximally exposed individual of 0.11 millirem at the plant boundary and a total population dose within a 50-mile radius of 0.045 person-rem (NRC 1996).

In 1995, releases of radioactive material to the environment from SRS operations resulted in a maximum individual dose from such releases of 0.064 millirem per year at the boundary in the north-northwest sector around the Site, and a maximum dose from liquid releases of 0.14 millirem per year, for a maximum total annual dose at the Site boundary of 0.20 millirem. The maximum dose to downstream consumers of Savannah River water -- 0.053 millirem per year -- occurred to users of the Port Wentworth public water supply (Arnett 1996). All releases are within the established regulatory guideline of 100 millirem for all exposure pathways. Table 3-10 lists the 1995 dose to the hypothetical maximally exposed individual and the exposure limits DOE has established in Order 5400.5.

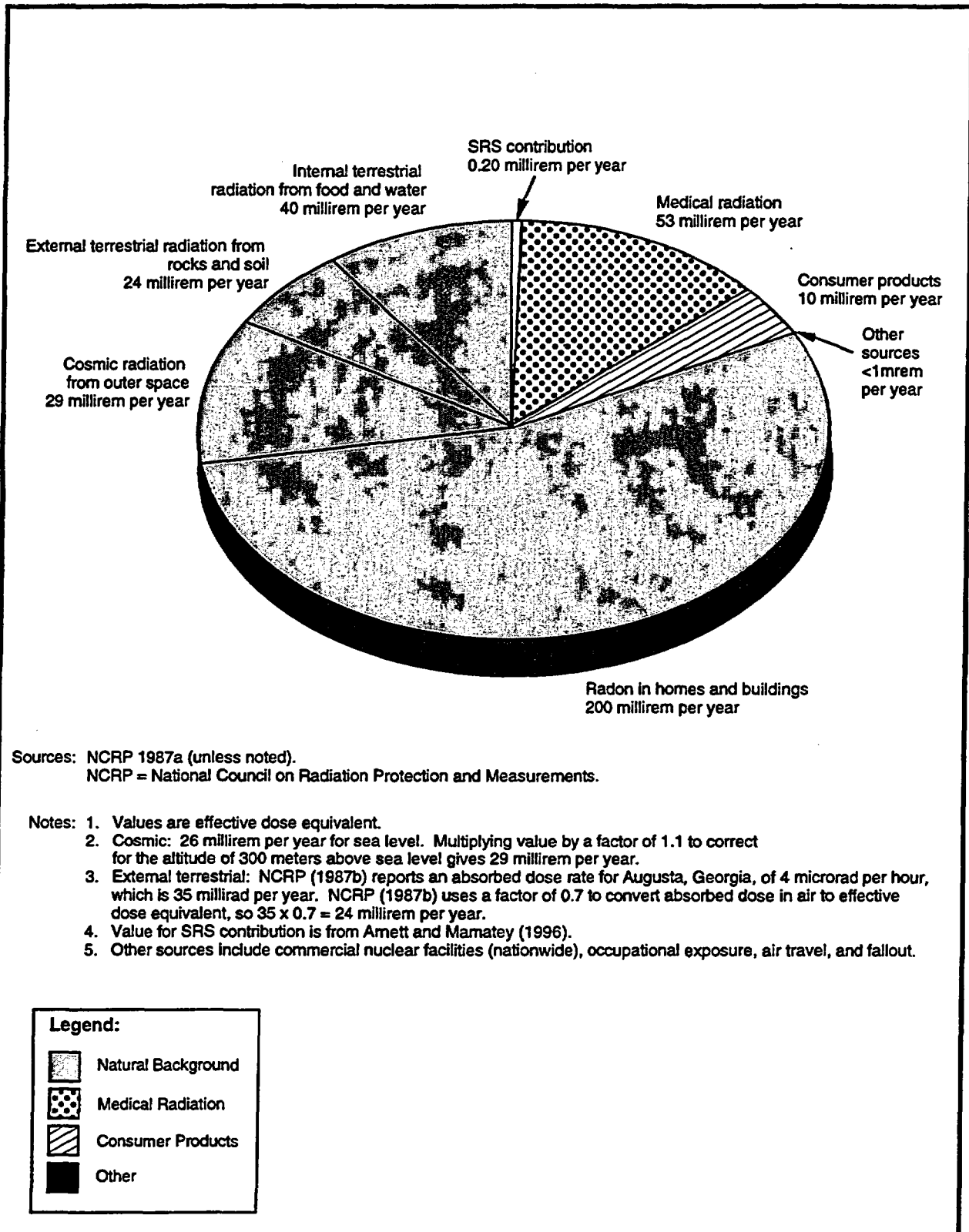

PK68-Z1-PC

Figure 3-15. Major sources of radiation exposure in the vicinity of the Savannah River Site.

**Table 3-10.** Doses to maximally exposed individual during 1995 and comparison to DOE limits (millirem per year).

Source	Dose	DOE standard
SRS air emissions	0.064	10
Consumption of water from Savannah River	0.053	4
All environmental pathways from SRS emissions	0.120 <sup>a</sup>	100

- a. This dose assumes that the same person receives both the air and liquid doses, which is highly unlikely.

The maximally exposed individual (MEI) is a hypothetical member of the public who would receive the highest radiation dose from the activity being considered. In determining the dose to the MEI, assumptions are made about the MEI's habits, such as where the MEI resides; how the MEI obtains water; and the amounts of meat, fruit, and vegetables ingested.

In 1990 the population within 50 miles of the SRS was about 620,000. In 1995 the collective effective dose equivalent to that population (i.e., the total dose received by all 620,000 people) was 3.5 person-rem from atmospheric releases. Downstream users of the Savannah River (some of whom might not live within 50 miles of the SRS) received a collective dose equivalent of 1.7 person-rem from liquid pathways (e.g., drinking water, consumption of contaminated fish and invertebrates, and exposure during recreational activities along the river) (Arnett 1996). Population statistics indicate that cancer caused 23.5 percent of the deaths in the United States in 1990 (CDC 1993). If this percentage of deaths from cancer continues, 23.5 percent of the U.S. population will contract a fatal cancer. Thus, in the population of 620,000 within 50 miles of the Site, 145,700 persons would be likely to contract fatal cancers from all causes. The population dose from the SRS of 3.5 person-rem from atmospheric pathways could result in 0.0018 additional latent cancer death expected in the same population (based on 0.0005 cancer death

per person-rem). Thus, the annual radiation dose from atmospheric doses from the SRS results in a calculated risk of cancer death that is essentially zero in comparison to the overwhelming incidence of fatal cancer expected in the same population from all causes. The 1.7 person-rem from liquid pathways similarly could result in 0.0009 additional latent cancers.

**Nonradiological.** The hazards associated with the alternatives described in this EIS include exposure to nonradiological chemicals in air and water pollution. Table 3-9 lists ambient air quality standards and concentrations for selected pollutants; Table 3-5 lists water quality standards and concentrations. These standards are designed to protect the public health. The concentrations from SRS sources, as listed in the tables, are lower than the established standards.

#### Worker Health

**Radiological.** One of the major goals of the SRS Health Protection Program is to keep worker exposures to radiation and radioactive material as low as reasonably achievable (ALARA). An effective ALARA program must balance minimizing individual worker doses with minimizing the collective dose of all workers in a given group.

The purpose of an ALARA program is to minimize doses from both external and internal exposures. Such a program must evaluate both doses with the goal to minimize the total effective dose equivalent. ALARA evaluations must consider individual and collective doses to ensure the minimization of both. For example, using many workers to perform extremely small portions of a task would reduce the individual worker doses to very low levels. However, the frequent worker changes could make the work inefficient, with the result that the total dose received by all workers could be significantly higher than if fewer workers received slightly higher individual doses.

DOE set administrative exposure guidelines at a fraction of the exposure limits to help enforce doses that are as low as reasonably achievable. SRS worker doses are typically well below the DOE guidelines. For example, the current DOE worker exposure limit is 5 rem per year, and the current SRS administrative exposure guideline was 0.80 rem per year.

Table 3-11 lists the maximum and average individual doses and SRS collective doses from 1988 to 1995.

**Table 3-11. SRS annual individual and collective radiation doses.<sup>a</sup>**

Year	Individual dose (rem)		Site collective dose (person-rem)
	Maximum	Average <sup>b</sup>	
1988	2.040	0.070	864
1989	1.645	0.056	754
1990	1.470	0.056	661
1991	1.025	0.038	392
1992	1.360	0.049	316
1993	0.878	0.051	263
1994	0.957	0.022	311
1995	1.335	0.018	247
1996	1.399	0.019	237

- a. Sources: Du Pont (1989), Petty (1993), WSRC (1991b, 1992, 1993, 1994, 1995, 1996c).  
 b. The average dose includes only workers who received a measurable dose during the year.

In 1995, 13,307 SRS workers received a measurable dose of radiation. Statistically, these workers would be likely to contract approximately 3,130 fatal cancers from all causes during their lifetimes; however, this cancer incidence rate depends on the age and sex distribution of the population. In 1995 this group received 247 person-rem and could experience as many as 0.1 additional cancer death due to their 1995 occupational exposure. Continuing operation of the SRS could result in as many as 0.1 additional cancer death for each year of operation, assuming future annual worker exposures continue at the 1995 level. Thus, as with the public, the annual radiation dose to SRS workers results in a calculated cancer risk that is extremely small in

comparison to the natural incidence of fatal cancer.

*Nonradiological.* A well-defined worker protection program is in place at the SRS to protect the occupational health of DOE and contractor employees. To prevent occupational illnesses and injuries and to preserve the health of the SRS workforce, contractors involved in the construction and operation of Site facilities establish and implement essential health and safety programs based on DOE Orders, DOE-prescribed standards, and contractor worker protection standards and procedures. The historic data in Tables 3-12 and 3-13 indicate that the implementation of health and safety programs based on these requirements results in accident and injury rates lower than those that occur in general industry. In addition, the Occupational Safety and Health Administration (OSHA) has established Permissible Exposure Limits (PELs) to regulate worker exposure to hazardous chemicals. These limits refer to airborne concentrations of substances and represent conditions under which nearly all workers could receive repeated exposures day after day without adverse health effects.

Table 3-14 lists OSHA-regulated workplace pollutants likely to be generated by the accelerator and its associated facilities and the applicable OSHA limit.

### 3.4.2 TERRESTRIAL ECOLOGY

Both the preferred and alternate APT sites are largely forested, dominated by stands of loblolly and slash pine. The loblolly stands on the preferred site are generally larger and older (10 to 12 inches in diameter; planted in the late 1950s) than those on the alternate site (about 10 inches in diameter and planted from 1972 to 1982). Younger stands of loblolly pine planted in the late 1980s cover about 20 percent of the preferred site. About 15 percent of the alternate site is longleaf pine planted in 1992. The stands of slash pine are generally older, dating back to the early 1950s (SRFS 1997). Understory species common in the pine stands include black



**Table 3-12.** Comparison of 1996 rates for SRS construction subcontractors and SRS construction to 1995 rates for general industry construction.<sup>a,b</sup>

Incident rate	SRS Construction Subcontractors <sup>a</sup>	SRS Construction Department <sup>a</sup>	Construction industry <sup>b</sup>
Total recordable cases	4.69	5.05	10.60
Total lost workday cases	1.48	1.93	4.90

a. Source: Saban 1997.

b. Source: Bureau of Labor Statistics 1995.

**Table 3-13.** Comparison of 1996 rates for SRS operations to 1995 incidence rates for private industry and manufacturing.<sup>a,b</sup>

Incident rate	SRS operations <sup>a</sup>	Private industry <sup>b</sup>	Manufacturing <sup>b</sup>
Total recordable cases	0.88	8.10	11.60
Total lost workday cases	0.40	3.60	5.30

a. Source: Saban 1997.

b. Source: Bureau of Labor Statistics 1995.

cherry, various oaks, and persimmon (Wike et al. 1994). Both sites also have small pockets of 40- and 60-year old upland hardwood stands of white oak, red oak, and hickory ranging in size from 8 to 12 inches in diameter (SRFS 1997). Understory species found on the preferred site include vacciniums (blueberries), sparkleberry, hickories, laurel oak, water oak, southern red oak, sweetgum, black cherry, persimmon, sassafras, and winged sumac. Ground cover includes Japanese honeysuckle, yellow jessamine, green brier, muscadine grape, spotted wintergreen, various grasses, legumes, and composites (Imm 1997). Figures 3-16 and 3-17 show the forest cover types of each site.

The SRS contains diverse reptile and amphibian communities due to its physiographic characteristics, large size, climate, variety of terrestrial and aquatic habitats, and protection from public intrusion (Gibbons and Patterson 1978; Gibbons and Semlitsch 1991). Thirty-six species of snakes, 26 frogs and toads, 17 salamanders, 12 turtles, 9 lizards, and the American alligator occur on the Site (Wike et al. 1994). Amphibian and reptile species likely to occur in the pine and upland hardwoods stands found at both APT sites include the southern toad, eastern fence lizard, and the black racer.

A variety of mammals also inhabit the SRS. White-tailed deer, feral hog, gray and red foxes, raccoon, gray and fox squirrels, eastern cottontail rabbit, and Virginia opossum are species that are likely to occur on the proposed accelerator sites (Cothran et al. 1991; Imm 1997).

A variety of birds including migrants and permanent residents occur in the pine forests and open acres of the SRS and would likely be found at both APT sites. Some 213 species of birds have been identified on the SRS (Wike et al. 1994). Species likely to utilize the pine dominated forests of the preferred and alternate sites include common native songbirds (e.g., Carolina wren, wood thrush, northern mockingbird, and rufous-sided towhee), neotropical migrant songbirds (e.g., pine warbler, prairie warbler, and red-eyed vireo), woodpeckers (e.g., red-bellied woodpecker and common yellow-shafted flicker), birds of prey (e.g., sharp-shinned hawk and common screech owl), and upland game birds (common bobwhite and eastern wild turkey) (Wike et al. 1994). Open areas such as powerlines, openings and roadsides would be utilized by northern mockingbird, mourning dove, rufous-sided towhee, and common bobwhite (Imm 1997). Appendix D

**Table 3-14. Potential Occupational Safety and Health Hazards and Associated Exposure Limits.\***

System	Hazard	Limit
Water chemistry laboratory	Acetic acid	10 parts per million
	Acetone	1,000 parts per million
	Ammonium persulfate	None established
	Argon	Asphyxiant
	n-butyl acetate	150 parts per million
	Ethanol	1,000 parts per million
	Ethylenediaminetetraacetic acid	None established
	Hexane	500 parts per million
	Hydrochloric acid	5 parts per million -- ceiling
	Hydrofluoric acid	3 parts per million
	Methanol	200 parts per million
	Nitric acid	2 parts per million
	Nitrogen	Asphyxiant
	Oxalic acid	1 milligram per cubic meter
	Pentane	1,000 parts per million
	Potassium hydroxide	2 milligrams per cubic meter -- ceiling
	Sulfuric acid	1 milligram per cubic meter
	Xylene	100 parts per million
	Demineralizer building radwaste reverse osmosis	Ammonium hydroxide
Citric acid		None established
1-(2-chloroallyl)-3,5,7-triaza-1-azoniaadamantane chloride		None established
Hexamethylenetetraamine hydrochloride		None established
Nitric acid		2 parts per million
Phosphoric acid		1 milligram per cubic meter
Sodium bicarbonate		None established
Sodium hydroxide		2 milligrams per cubic meter
Tetrasodium EDTA		None established
Cryogenics maintenance facility		Hydrofluoric acid
	Nitric acid	2 parts per million
	Phosphoric acid	1 milligram per cubic meter
HVAC and process chillers	Hydrotreated heavy naphthentic distillates	5 milligrams per cubic meter
	Potassium hydroxide	2 milligrams per cubic meter -- ceiling
	1-h-benzotriazole, methyl	None established
	Ethane, 1,2 - dichlorotetrafluoro (Freon-114)	1,000 parts per million
Water treatment facility	Noise	90 dBA
	Anionic polymer	None established
	5-chloro-2-methyl-4 isothiazolin-3-one	0.1 milligram per cubic meter
	2,2-dibromo-3-nitrilopropionamide	2.0 milligrams per cubic meter manufacturer recommended limit
	Hydrazine	0.1 part per million
	2-methyl-4-isothiazolin-3-one	None established
	Sodium molybdate	5 milligrams per cubic meter
	Sodium nitrate	None established
	Sulfuric acid	1 milligram per cubic meter
	Noise	90 dBA

Table 3-14. (continued).

System	Hazard	Limit
Linear accelerator	Electromagnetic frequencies	Frequency dependent ACGIH recommendations
	Ozone	0.1 part per million
	Nitric acid	2 parts per million
	Lasers	Wavelength dependent ACGIH recommendations
	Visible light	Wavelength dependent ACGIH recommendations

- a. The OSHA permissible exposure limits listed in Tables Z-1-A or Z-2 of the OSHA General Industry Air Contaminants Standard (29 CFR 1910.1000) provided if appropriate. These limits, unless otherwise noted (e.g., ceiling), must not be exceeded during any 8-hour work shift of a 40-hour work week. If the designation of "ceiling" is associated with one of the limits listed in this table, the air concentration must not exceed that limit during any part of the workday.

of the *Final Environmental Impact Statement, Shut-down of the River Water System at the Savannah River Site* (DOE 1997) contains a comprehensive list of wildlife found on the Savannah River Site.

### 3.4.3 AQUATIC ECOLOGY

The aquatic resources of the SRS have been the subject of intensive study for more than 40 years. Research has focused on the flora and fauna of the Savannah River, the five tributary streams of the river that drain the Site, and two manmade impoundments (Par Pond and L-Lake) that DOE built to receive heated effluents from nuclear production reactors. Detailed information on SRS aquatic biota and aquatic ecosystems appears in several monographs (Patrick, Cairns, and Roback 1967; Bennett and McFarlane 1983), the 8-volume Comprehensive Cooling Water Study (Du Pont 1987), and a number of environmental impact statements concerned with SRS water resources (DOE 1984; 1987; 1990; 1997).

#### Savannah River

Since 1951, DOE has sponsored continual monitoring of periphyton or attached algae, in the Savannah River above, below, and adjacent to the SRS (Wike et al. 1994). These ongoing studies, conducted by the Academy of Natural Sciences of Philadelphia (ANSP) include semi-monthly surveys of diatom communities, quarterly cursory studies of both diatom and non-

diatom algae, and detailed surveys of attached algae every 4 years. The annual environmental reports published annually by DOE (e.g., Arnett and Mamatey 1996) summarize the results of the ANSP studies. The studies have generally concluded that SRS effluents do not have an adverse impact on the health of the Savannah River.

**Periphyton** – Small organisms, such as algae, that attach to rocks, submerged logs, stems, and leaves of plants, and other substrates in streams, rivers, ponds, and lakes.

**Benthic macroinvertebrates** – Small animals that live on the bottom of a body of water that are visible to the naked eye and have no vertebral column (backbone), such as larval aquatic insects (mayflies and caddisflies) and mollusks (clams and mussels).

**Plankton** – Microscopic organisms in rivers, ponds, lakes, and reservoirs that are suspended in the water column and whose movements and distribution are largely determined by winds and currents. Phytoplankton are microscopic plants (algae); zooplankton are microscopic animals (e.g., "water fleas").

**Ichthyoplankton** – Eggs and early larvae of fish that are carried passively with currents in rivers and lakes.

Benthic macroinvertebrates (small, bottom-dwelling organisms) such as insect larvae were

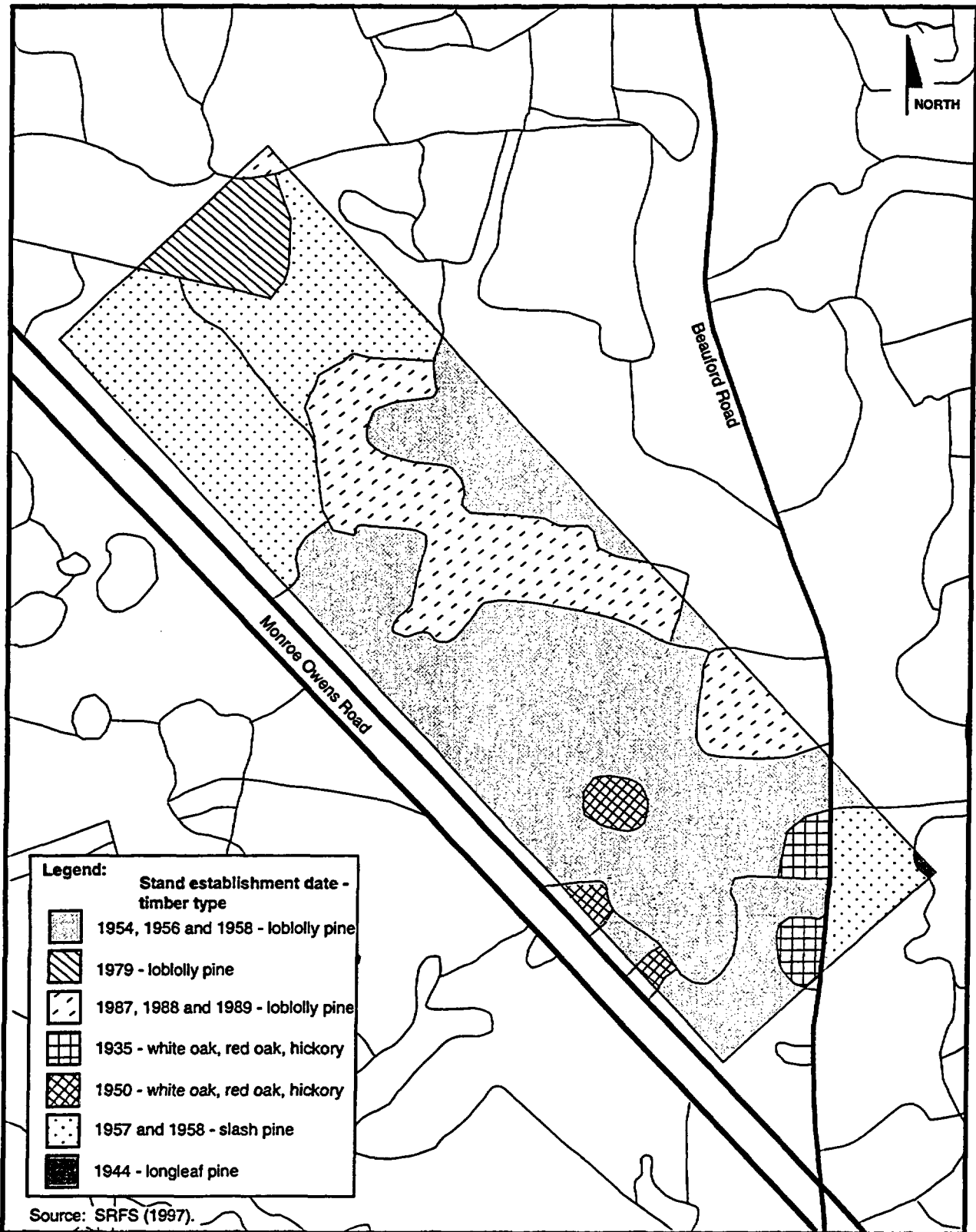

PK68-Z1-PC

Figure 3-16. Forest cover of preferred APT site.

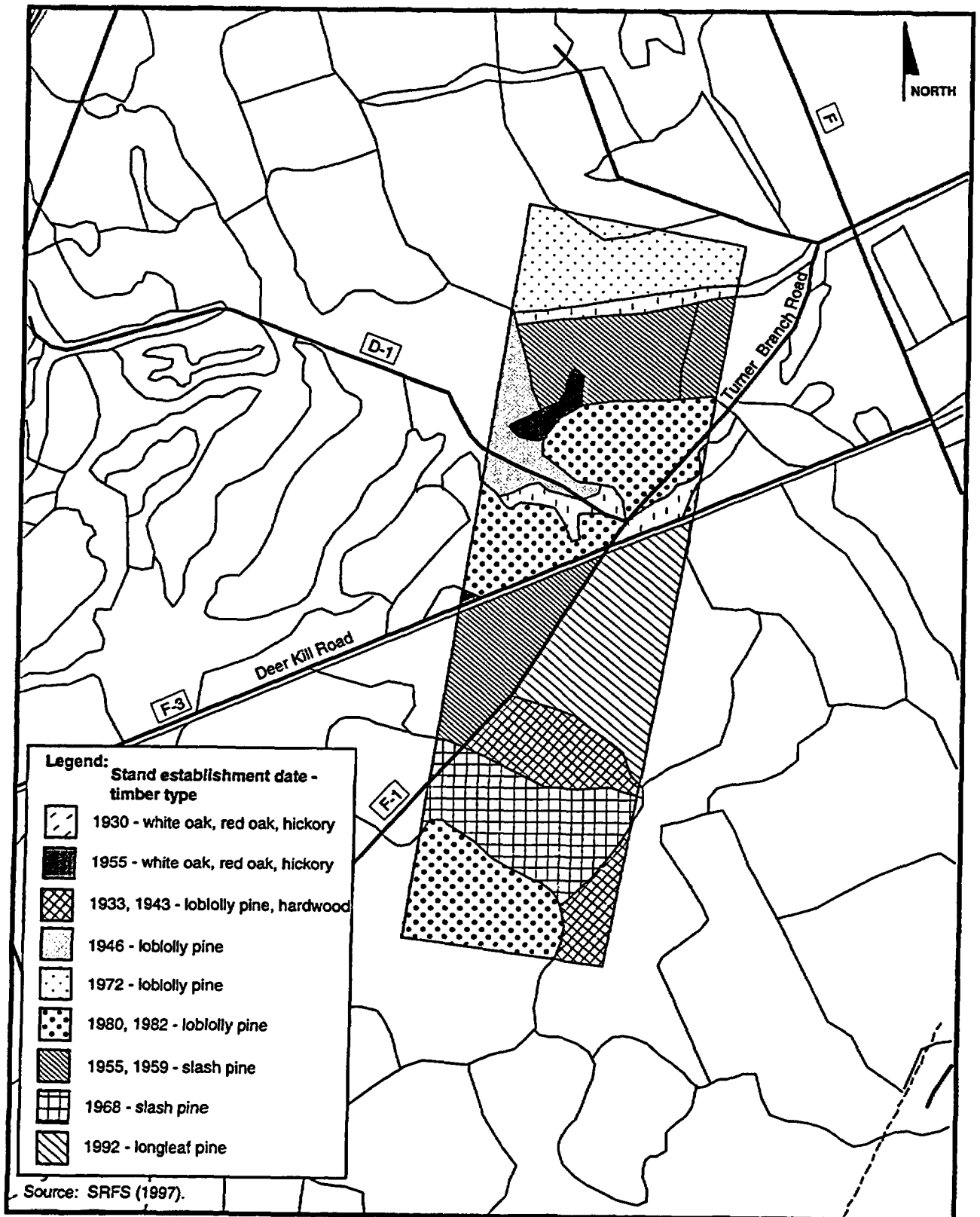

Figure 3-17. Forest cover of alternate APT site.

PK68-Z1-PC

collected monthly at nine locations in the Savannah River from October 1983 through September 1985 using artificial substrate samplers (Wike et al. 1994). Table 3-15 summarizes the results of the study. These same locations (plus two additional stations) were sampled quarterly over the same period with drift nets to determine if organisms were moving from location to location or abandoning particular areas.

During the 2-year study, 146 macroinvertebrate taxa were collected from the Savannah River. Of these, 96 taxa were collected from the multiplate samplers and 50 were collected exclusively in the drift. Dipterans accounted for 46.5 to 73.8 percent of the organisms collected from the multiplate samplers (Table 3-15). The most commonly collected dipterans included chironomids and blackflies. Other common insect groups included Trichoptera (caddisflies; 18.5 to 30.3 percent), Ephemeroptera (mayflies; 5.2 to 17.3 percent), and Plecoptera (stoneflies; 1.2 to 3.1 percent). Oligochaetes and amphipods were also locally abundant at one or more stations.

The most abundant groups of macroinvertebrates in the drift were oligochaetes (aquatic earthworms) and chironomids (midges). Other common taxa included nematodes, *Hydracarina*, amphipods, mayflies, caddisflies, and blackflies.

Most fisheries studies in the Savannah River can be grouped into two categories: those emphasizing the reproductive requirements and success of striped bass and those designed to assess the impacts of SRS operations on fish spawning and the survival of fish eggs and larvae. Early efforts concentrated on the identification of striped bass spawning areas and the assessment of tide-gate operations on striped bass spawning success. Recent studies have focused on the reproduction, recruitment, and habitat requirements of striped bass (Wike et al. 1994).

Programs designed to assess the impacts of SRS operations began in 1977 with studies on the entrainment of American shad eggs in the SRS Savannah River intakes (Wike et al. 1994). Beginning in 1982, the SRS initiated a much larger project in the midreaches of the Savannah River

that, at one point, encompassed 26 sample stations in the river (plus 36 more in oxbows and the mouths of tributary creeks) between River Miles 18.4 and 116.3. Specific project objectives were to assess entrainment rates for fish eggs and larvae at SRS water intakes and, more generally, the impacts of SRS operations on fish spawning. This study also generated information on the distribution and abundance of ichthyoplankton (fish eggs and plankton) in the river.

Over the 1983-1985 period, an average of 7,603 fish were impinged on river water pump intake screens each year (Wike et al. 1994). Entrainment losses averaged 10 million eggs and 18.8 million larvae annually. Species most affected by impingement were bluespotted sunfish and threadfin shad. Entrainment losses were primarily American shad and other clupeids.

Additional entrainment-related studies were conducted during 1991 (Dames and Moore 1992). A total of 33 taxa were collected during this study. American shad and striped bass accounted for 76 percent and 5 percent, respectively, of the fish eggs collected. Minnows and spotted sucker comprised most of the fish larvae collected. These patterns were generally similar to those observed during the earlier studies. Four sturgeon larvae were collected, but it was not determined if these were larvae of the Atlantic sturgeon or the endangered short-nose sturgeon.

### Upper Three Runs

At least 551 species of aquatic insects occur in Upper Three Runs (Wike et al. 1994). A 1993 study identified 93 species of caddisflies, including three not previously found in South Carolina and two that were new to science. In addition, Davis and Mulvey (1993) identified a rare clam species in the Upper Three Runs drainage. In 1997, the U.S. Fish and Wildlife Service redesignated the American sand-burrowing mayfly, a relatively common mayfly in Upper Three Runs, a species of Federal concern from its former Category 2 species status

**Table 3-15.** Relative abundance (percent) of major taxonomic groups of macroinvertebrates on Hester-Dendy Multiplate Samplers in the Savannah River, 1984-1985.

Taxon	Station (river mile)								
	152.2	152.0	150.8	150.4	141.7	141.5	137.7	129.1	128.9
Oligochaeta (aquatic earthworms)	2.4	2.0	0.4	0.2	<0.1	0.2	4.2	0.8	0.3
Amphipoda (scuds)	<0.1	<0.1	<0.1	<0.1	<0.1	1.4	0.2	<0.1	<0-1
Ephemeroptera (mayflies)	6.0	5.6	6.1	5.2	8.5	10.2	13.4	17.3	16.3
Plecoptera (stoneflies)	1.2	1.5	1.3	1.2	1.2	1.6	3.1	1.9	2.0
Trichoptera (caddisflies)	25.6	22.4	27.5	18.5	29.8	30.3	29.6	30.0	22.1
Diptera (true flies)	63.2	66.3	63.6	73.8	59.5	54.8	46.5	48.7	58.0
Other <sup>a</sup>	1.6	2.2	1.1	1.1	1.0	1.5	3.0	1.3	1.3

Source: Wike et al. (1994).

a. Taxa that each comprised less than 1 percent of the organisms collected at a station; these included Turbellaria, Nematoda, Hirudinea, Gastropoda, Pelecypoda, Hydracarina, Decapoda, Collembola, Odonata, Hemiptera, Coleoptera, and Lepidoptera.

(Fridell 1997). This species is sensitive to siltation, organic loading, and toxic releases (Wike et al. 1994). Between 1987 and 1991, the density and variety of insects collected from Upper Three Runs decreased for unknown reasons. Data collected more recently indicate, however, that the insect communities might be recovering (Wike et al. 1994).

Fish were sampled in Upper Three Runs in 1984-1985, 1992, and 1993. The 1984-1985 samples were part of the Comprehensive Cooling Water Study, and included ichthyoplankton collections from the lower reaches of the stream. The 1992 samples were part of an effort to characterize fish assemblages on the SRS and assess possible impacts resulting from the outcropping of contaminated groundwater from F- and H-Areas into Upper Three Runs (Wike et al. 1994).

The fish assemblages at most Upper Three Runs sample stations were dominated by shiners and sunfishes. Larger predatory and bottom-feeding species were typical of those found in larger streams. The smaller tributary sample stations were dominated by shiners, followed by pirate perch, madtoms, and darters -- a pattern typical of unimpacted streams on the SRS (Paller 1994).

### Pen Branch and Indian Grave Branch

The macroinvertebrate communities of Pen Branch were surveyed from 1983 to 1985 when K-Reactor was discharging heated effluent to that stream, and in 1988 and 1989 after the K-Reactor shutdown (Wike et al. 1994). Before the shutdown, portions of Pen Branch directly downstream from the reactor outfall contained few benthic macroinvertebrate taxa, while areas farther removed from the outfall (such as the Savannah River Swamp) had a more diverse benthic macroinvertebrate community. The macroinvertebrates in thermally impacted areas were generally pollution-tolerant forms (e.g., chironomids, nematodes, and oligochaetes) capable of surviving high temperatures and low oxygen levels. After the K-Reactor shutdown, macroinvertebrate communities began to recover, with densities and taxa richness generally higher (86 taxa collected in 1988-1989 versus 51 in 1984-1985). The benthos continued to be dominated by pollution-tolerant groups (e.g. chironomids and blackflies) after K-Reactor operations ended.

Aho et al. (1986) investigated the community structure of fishes in Pen Branch, Meyers Branch, and Steel Creek in 1984 and 1985 as part of the Comprehensive Cooling Water

Study. Steel Creek had the highest diversity, with slightly lower values for Pen Branch and Meyers Branch. In each stream, diversity was highest at downstream locations.

Upper reaches of Pen Branch were characterized by low species richness (11 species collected) and diversity: six species (mud sunfish, brown bullhead, dollar sunfish, chubsucker, redbfin pickerel, and mosquitofish) made up more than 91 percent of all fish collected (Aho et al. 1986). Lower reaches of Pen Branch contained more species (27), a higher percentage of which were small-bodied species (e.g., yellowfin shiners, madtoms, and darters) commonly found in blackwater streams of the Coastal Plain.

After the K-Reactor shutdown, fish rapidly recolonized Pen Branch and Indian Grave Branch (Wike et al. 1994). Yellowfin shiners, bluehead chubs, and pirate perch were the most common species in the upper reaches of the stream. Largemouth bass, lake chubsucker, redear sunfish, and redbreast sunfish were most abundant in the middle reaches. Brook silversides, coastal shiners, spotted sunfish, and lake chubsuckers were most common in the delta. Indian Grave Branch collections were dominated by four species: spotted sucker (22.2 percent of total), coastal shiner (18.5 percent), lake chubsucker (14.8) percent, and redbreast sunfish (14.8 percent).

### Lower Three Runs

The macroinvertebrate communities of Lower Three Runs were last surveyed in 1983 and 1985 as part of the Comprehensive Cooling Water Study (Wike et al. 1994). The macroinvertebrate community just downstream of the Par Pond dam was characterized by extremely high densities, most notably midges (chironomids). Caddisflies and blackflies were also abundant. Many of these organisms are filter feeders, presumably taking advantage of nutrients carried downstream from Par Pond.

At a station roughly 16 miles downstream of the Par Pond dam, densities of macroinvertebrates

were reduced, but species richness (diversity) was high (Wike et al. 1994). Common taxa included a number of midges, a stonefly, two mayfly species, and a caddisfly.

The macroinvertebrate community in the lower reach of Lower Three Runs (just above its confluence with the Savannah River) was characterized by relatively high densities and relatively low diversity. Midges (chironomids) made up 84 percent of all organisms collected. Other common organisms included a mayfly and a caddisfly.

Flows in Lower Three Runs during the 1984-1985 study were higher than those observed in more recent years, and the 1984-1985 community characterizations might not reflect current conditions. However, general upstream-to-downstream trends likely remain the same: relatively high densities of macroinvertebrates in the area below the dam and at the mouth of the stream; and highest species richness and diversity in middle reaches of the stream.

Surveys of fish in Lower Three Runs were conducted in 1990 as part of an effort to assess fish community structure in SRS streams (Wike et al. 1994; Paller 1994). Fish communities showed pronounced upstream-to-downstream trends. Upstream areas where the stream is shallow and relatively narrow were dominated by a mixed assemblage of sunfish (primarily redbreast and spotted sunfish), shiners, and pirate perch. More downstream areas, which are typically deeper and wider, were dominated by spotted suckers, largemouth bass, and creek chubsuckers. This pattern -- a mixed community of small-to-medium sized insectivorous species at shallow, narrow stream sites and a community of large benthic insect-eating and predatory fish at wider, deeper sites -- was fairly typical of southeastern coastal plain streams (Paller 1994).

### Par Pond System

DOE has not conducted a systematic survey of the flora and fauna of Ponds 2, 5, and C (the "pre-cooler" ponds). For this EIS, the Department conducted a cursory field survey of



plants and animals on July 14, 1997 (Kennemore 1997). This survey and interviews of scientists from the Savannah River Ecology Laboratory led to the development of basic information on the ecological communities of Ponds 2 and 5. Pond C was the subject of several studies of behavioral thermoregulation in fishes (and recurring fish kills) in the 1970s and 1980s, but little is known of its plant and invertebrate communities.

Because the pre-cooler ponds historically received water from the River Water System and Par Pond (recirculated through Pumphouse 6G), DOE assumes that the aquatic communities of these ponds represent a less diverse subset of the communities in Par Pond. In addition, DOE assumes that the pre-cooler ponds contain periphyton (attached algae) communities similar to those in Par Pond, which are dominated by three major taxonomic groups -- green algae, diatoms, and blue-green algae (Wilde 1985; Wilde 1987). Community composition of the periphyton in these ponds almost certainly changes seasonally, in response to changes in temperature, light intensity, rainfall, and nutrient inputs from the watershed. Similarly, DOE assumes that the pre-cooler ponds contain macroinvertebrate communities numerically dominated by dipterans ("true" flies) and oligochaetes (aquatic earthworms) with small numbers of aquatic insects such as odonates (dragonflies), trichopterans (caddisflies), and ephemeropterans (mayflies) also present (Wilde 1985; Wilde 1987). The following fish species are known to occur or likely occur in Ponds 2, 5, and C: gizzard shad, redbreast sunfish, golden shiner, true shiners (*Notropis* spp.), lake chubsucker, bullheads (*Ameiurus* spp.), pirate perch, mosquitofish, brook silverside, redbreast sunfish, warmouth, bluegill, spotted sunfish, and largemouth bass. The relative abundance of these species is unknown, but bluegill and largemouth bass are particularly abundant in Pond C and Par Pond (Bennett and McFarlane 1983; Aho and Anderson 1985).

The aquatic ecology of Par Pond was studied intensively from January 1984 through June

1985 as part of a Clean Water Act Section 316(a) thermal effects demonstration. It found that the reservoir supports a diverse phytoplankton (algae) community; green algae were most abundant, followed by diatoms and blue-green algae (Chimney, Cody, and Starkel 1985). In terms of density, diatoms were the most abundant algal group. In terms of primary productivity, chlorophyll-*a* concentrations and algal community composition, Par Pond was similar to other lakes in the southeastern United States.

Protozoans and rotifers dominated the zooplankton community, with protozoans more abundant in the winter and spring and rotifers in the summer (Chimney, Cody, and Starkel 1985). Larger-bodied cladocerans (water fleas) and copepods were most abundant in the summer, indicating a lack of strong pressure from fish predation. As with phytoplankton, the zooplankton community in Par Pond was similar to that in other southeastern lakes.

The fishes of Par Pond have been studied intensively for more than 25 years; Wike et al. (1994) lists 50 major studies (journal articles and monographs) dealing with Par Pond fish. Most of these studies were concerned with the effects of thermal discharges from SRS reactors on fish behavior, physiology, and ecology. Population studies in the 1970s and 1980s showed largemouth bass, bluegill, black crappie, lake chubsucker, brook silverside, and mosquitofish to be particularly abundant in Par Pond (Wike et al. 1994).

The 1991-1995 drawdown of Par Pond temporarily affected fish populations due to reduced spawning and nursery habitat for many species and increased predation on small forage species [e.g., brook silverside, golden shiner, and minnows (*Notropis* species)] and young-of-the-year sunfish that use littoral zone macrophyte beds for escape cover.

#### 3.4.4 WETLAND ECOLOGY

The SRS has extensive widely distributed wetlands, most of which are associated with floodplains, creeks, or impoundments. Using

information from a land cover and land use geographic information system data base developed from multirate aerial photography taken in the late 1980s, DOE estimates that SRS wetlands cover almost 49,000 acres (Wike et al. 1994). There are about 300 Carolina bays (Kirkman et al. 1996), a wetland feature unique to the southeastern United States, on the Site; they exhibit extremely variable hydrology with resident plant communities ranging from herbaceous marshes to forested wetlands.

### Savannah River

The Savannah River supports an extensive swamp, covering about 9,400 acres of the SRS; a natural levee separates the swamp from the river. Predominating the forest cover in the swamp is second-growth bald cypress, black gum, and other hardwood species. The five streams draining the Site have floodplains with bottomland hardwood forests or scrub-shrub wetlands in varying stages of succession. Dominant species include red maple, box elder, bald cypress, water tupelo, sweetgum, and black willow (Wike et al. 1994).

### Pen Branch-Indian Grave Branch

The Pen Branch-Indian Grave Branch system would receive blowdown from the K-Area natural-draft cooling tower, if DOE chose it to cool the heated water from the APT facilities. At present, the stream receives nonthermal effluents (nonprocess cooling water, ash basin effluent waters, powerhouse wastewater, and sanitary wastewater) from K-Area and sanitary effluents from the Central Shops Area. Since shutdown of the K-Reactor, wetlands in the Pen Branch corridor and delta have shifted from nonpersistent vegetation and water to more persistent vegetation and drier conditions. Acreage in the stream corridor consists predominantly of bottomland hardwood (64 percent) along with willow (18 percent), scrub-shrub (10 percent), deep water (9 percent), and mud flats (6 percent). The delta is dominated by willow (36 percent), cattails (32 percent), shallow water (17 percent), scrub-shrub (9 per-

cent), and deep water (4 percent) (Wike et al. 1994).

### Par Pond System

Since the P-Reactor shutdown in 1988, the Par Pond system has not received heated effluent. Flow from the River Water System stopped in early 1996 (Cooney et al. 1996). The canals connecting the pre-cooler ponds are lined with rip-rap and contain a heavy growth of alligator-weed. Zones of dense emergent vegetation along the margins of the ponds provide habitat for a variety of aquatic and semi-aquatic animals (water snakes, frogs, turtles, and wading birds). Cattails and burweed dominate the shoreline of Pond 2; sedges, grasses, and bulrushes are also present but are minor components of the emergent vegetation community. The Pond 5 shoreline is dominated by cattails, with arrowhead, rushes, sedges, and bulrushes as minor components. Pond C, like Pond 5, has a shoreline dominated by cattail, with spike-rush and water-shield in some areas (Kennemore 1997).

In March 1991 DOE discovered a depression on the downstream slope of the Par Pond dam. While DOE was determining what repairs were needed, it lowered the water level from 200 feet to 181 feet. As a result, the wetlands vegetation that developed with the fairly stable water levels that characterized Par Pond from 1958 to 1991 were exposed to drying conditions, and extensive losses occurred along the shoreline (DOE 1997). In the spring of 1995, DOE restored Par Pond to a full pool level. Shoreline aquatic vegetation is undergoing rapid redevelopment. Maidencane, the current dominant emergent species, has become less abundant in deeper water since DOE refilled the pond. Several other species that dominated wetland areas before the drawdown are increasing in abundance, including lotus, water lily, watershield and spike rush. Cattails are scattered throughout most of Par Pond, and long beds are forming in the Middle Arm. In 1996 lotus expanded into areas formerly dominated by cattails. Woody species (e.g., loblolly pine, willow, and red maple) that colonized the edge of the reservoir during the

drawdown, are declining in abundance since the refill, although there is a band of willow and red maple around the margin of the lake (DOE 1997).

For the most part, wetlands along Lower Three Runs downstream of Par Pond are bottomland-hardwood swamps associated with the floodplain (DOE 1990). Bottomland hardwoods on the SRS are typical of the mixed hardwood forests in low wet areas of the southeastern Coastal Plain (Workman and McLeod 1990). Common tree species in these areas tolerate flooding of limited depth, which is normally restricted to late winter and early spring when the plants are dormant (Whipple, Wellman, and Good 1981). This includes several species of oak, sweetgum, cottonwood, American elm, sycamore, and red maple. In addition, some scrub-shrub and other emergent wetlands occur in the main channel and tributaries of Lower Three Runs. Although most influenced by Par Pond releases, these bottomland areas have also been affected by beaver activity (DOE 1990). Some cypress-tupelo areas are near the confluence of Lower Three Runs and the Savannah River (DOE 1997).

Mammal species found in the wetland areas include beaver, otter, weasel, marsh rabbit, muskrat, star-nosed mole, mink, rice rat, and raccoon (Wike et al. 1994). Extensive studies of reptile and amphibian use of the wetlands of the SRS have been conducted by the Savannah River Ecology Laboratory (Gibbons and Semlitsch 1991; Schalles et al. 1989). Christmas bird counts and ecological inventories provide information on the avian species common to SRS wetlands (Wike et al. 1994).

### 3.4.5 THREATENED AND ENDANGERED SPECIES

Table 3-16 lists the threatened and endangered species that occur on the SRS (Wike et al. 1994). There is no designated critical habitat for any listed threatened or endangered species on the proposed APT sites.

**Table 3-16. Threatened and endangered species of the Savannah River Site.**

Common name	Status
Bald eagle	T <sup>a</sup>
Wood stork	E <sup>b</sup>
Red-cockaded woodpecker	E
American alligator	T/SA <sup>c</sup>
Shortnose sturgeon	E
Smooth coneflower	E

- a. T - Federally threatened species.
- b. E - Federally endangered species.
- c. T/SA - Threatened due to similarity of appearance to the endangered American crocodile.

The smooth coneflower is the only endangered plant species on the SRS. The closest colony of this plant is on Burma Road approximately 1 mile south of the intersection with Road C, approximately 6 miles from the preferred APT site. A second colony is near the junctions of SRS Roads 9 and B (LeMaster 1994). The habitat of the smooth coneflower is open woods, cedar barrens, roadsides, clearcuts, and power line rights-of-way. Optimum sites are characterized by abundant sunlight and little competition in the herbaceous layer (FWS 1995). Suitable habitat for this species occurs throughout the SRS, including the powerline right-of way adjacent to the preferred APT site, though none have been found in the vicinity of either sites (Imm 1997).

Wood storks feed in the Savannah River Swamp and the lower reaches of Steel Creek, Pen Branch, Beaver Dam Creek, and Fourmile Branch. They foraged at Par Pond during the drawdown in 1991 (Bryan 1992). Neither of the APT sites contains suitable foraging habitat for wood storks, and no storks have been reported in these areas (Imm 1997). Bald eagles nest near Par Pond and L-Lake and forage in these reservoirs (USDA 1988; Bryan et al. 1996; LeMaster 1996). One bald eagle was reported flying near the junction of SRS Roads E and 4, south of H-Area, in November 1985 (Mayer,

Kennamer, and Hoppe 1986). However, neither APT site contains suitable foraging habitat for bald eagles (Imm 1997). The red-cockaded woodpecker inhabits and uses open pine forests with mature trees (older than 70 years for nesting and 30 years for foraging). While the preferred site contains no red-cockaded woodpecker nesting or foraging areas in use by the birds, it does contain unoccupied habitat approaching suitable age (LeMaster 1997).

Shortnose sturgeon, typically residents of large coastal rivers and estuaries, have not been collected in the tributaries of the Savannah River that drain the SRS. Sturgeon ichthyoplankton have been collected in the river near the Site (Wike et al. 1994).

The American alligator occurs in a variety of SRS habitats, including river swamps, small streams, abandoned farm ponds, and Par Pond and L-Lake (Du Pont 1987). Par Pond contains the largest concentration of alligators, with more than 200 animals (LeMaster 1996). High stream flows and temperatures from K-Reactor operations made most of Pen Branch unsuitable for alligators until 1988, but there are indications that the lowest reaches of the stream are being recolonized (Wike et al. 1994). Lower Three Runs has historically supported a reproducing population of alligators, most of which are concentrated in an area below the Par Pond dam where they are protected from human encroachment (Murphy 1981; Wike et al. 1994).

### 3.5 The Regional Economic and Social Environment

This section describes the economic and demographic baseline for the area around the SRS. The purpose of this information is to assist in understanding the impacts accelerator construction and operation could have on community service needs and prospects for economic growth, and any disproportionate impacts they could have on minority and low-income neighborhoods.

#### 3.5.1 CURRENT ECONOMIC CONDITIONS

The socioeconomic region of influence for the proposed action is a six-county area around the SRS where the majority of Site workers reside and where socioeconomic impacts are likely to occur. The six counties are Aiken, Allendale, Barnwell and Bamberg in South Carolina, and Columbia and Richmond in Georgia. *Socioeconomic Characteristics of Selected Counties and Communities Adjacent to the Savannah River Site* (HNUS 1997) contains details on the region of influence, as well as most of the information discussed in the following sections.

##### 3.5.1.1 Regional Fiscal Conditions

The counties with the greatest potential to be affected by activities at the Savannah River Site are Aiken and Barnwell in South Carolina and Richmond and Columbia in Georgia. Data available for fiscal year 1994 for these counties indicate that revenues exceeded expenses in all but Columbia County. Barnwell County had the lowest revenues at \$8 million. Columbia, Aiken, and Richmond Counties followed with \$20, \$30, and \$62 million, respectively. *Socioeconomic Characteristics of Selected Counties and Communities Adjacent to the Savannah River Site* (HNUS 1997) contains the funding levels for the Cities of Aiken, Barnwell, and New Ellenton, South Carolina, and Augusta, Georgia.

##### 3.5.1.2 Employment and Income

In 1994 the total civilian labor force for the region of influence was 206,518, with 6.9 percent unemployment. The unemployment rate for the United States for the same period was 6.1 percent. In 1994 total employment according to Standard Industrial Code sectors ranged from 479 workers in the mining sector (e.g., clay and gravel pits) to 58,415 workers in the services sector (e.g., health care and education). Average per capita personal income in 1993 (adjusted to 1995 dollars) was \$18,867, in comparison to the U.S. figure of \$21,937.

Based on a detailed workforce survey completed in the Fall of 1995, the SRS had 16,625 workers (including contractors, permanent and temporary workers, and persons affiliated with Federal agencies and universities who work on the Site) with a total payroll of slightly over \$634 million. DOE has continued to reduce the size of the Site workforce. By March 1997 the workforce was 15,112.

### 3.5.1.3 Housing

In 1990 (the latest housing census data), there were 167,356 year-round housing units in the six-county region, approximately 12 percent of which were vacant. About 68 percent of the year-round housing are single-unit structures, 14 percent are mobile homes, and 18 percent are multi-unit structures. According to the Multiple Listing Service, more than 3,500 residential housing units were for sale in January 1997 in the greater Augusta area.

### 3.5.1.4 Community Services and Infrastructure

**Water Supply.** The 55 public water systems in the region of influence serve almost 90 percent of the population in the six counties. In areas not served by a public water system, private wells supply water to individual residences. Most county and municipal water supply systems obtain water from deep wells. Other jurisdictions derive their water from nearby creeks and rivers such as the Savannah River. In 1996 all 55 systems were operating at well below capacity (50 percent or less) and could accommodate additional demand.

**Wastewater Treatment.** The region has 15 major public wastewater treatment facilities that provide sewer services to almost 60 percent of the housing units, serving almost 70 percent of the population. In 1996 four of the six counties (Aiken, Barnwell, Columbia, and Richmond) are at 50- to 60-percent capacity, while Allendale County is at capacity and Bamberg County exceeds its treatment capacity.

**Solid Waste.** As discussed in Section 3.3.6, the Three Rivers Waste Authority is building a 1,400-acre solid waste management facility on the SRS with projected operation in mid-1998. Three of the four South Carolina counties in the region of influence (Aiken, Bamberg, and Barnwell) are participating in the project. Allendale County will not participate, and will transport its solid waste to neighboring Hampton County. The other three counties will close their existing landfills when the Three Rivers facility opens. The new facility will receive as much as 2,000 tons of solid waste a day, and will accommodate member-county and SRS solid waste needs for at least the next 20 years.

Both Georgia counties in the region (Richmond and Columbia) have landfills. The Richmond County landfill has an area of approximately 1,100 acres and probably can accommodate the county's waste at current generation rates for the next 100 years. Columbia County operates a landfill of approximately 130 acres. To extend the life of this landfill, a 40-acre site in the county has received a permit to operate as an inert landfill to accept lawn trimmings and wood waste; this could be expanded to construction and demolition waste. Two smaller landfills serve the two municipalities in the county.

## 3.5.2 CURRENT SOCIAL CONDITIONS

### 3.5.2.1 Population

Based on state and Federal agency surveys and trends, the estimated 1994 population in the region of influence was 457,824. More than 89 percent lived in Aiken (29 percent), Columbia (17 percent), and Richmond (43 percent) Counties (see Table 3-17). The population in the region grew at an average annual growth rate of 1.2 percent during the 1980s, which slowed to less than 1 percent between 1990 and 1994. The positive net immigration that occurred in the region was consistent with population growth in Georgia and South Carolina. Columbia County experienced the greatest in

**Table 3-17.** Population distribution and percent of region of influence for counties and selected communities.

Jurisdiction	1994 Population	1994 % ROI
South Carolina	3,663,984	
Aiken County	132,060	28.8
Aiken <sup>a</sup>	24,929	5.4
Jackson <sup>a</sup>	1,876	0.4
New Ellenton <sup>a</sup>	2,494	0.5
North Augusta <sup>a</sup>	17,610	3.8
Allendale County	11,690	2.6
Bamberg County	16,702	3.6
Barnwell County	21,418	4.7
Barnwell <sup>a</sup>	5,600	1.2
Georgia	7,055,336	
Columbia County	79,922	17.5
Richmond County	196,032	42.8
Augusta <sup>a</sup>	43,459	9.5
Six-county total	457,824	
United States	260,341,000	

a. City data presented is also included in the respective counties.

crease, 146 percent of the total net increase. Aiken County was second with 53 percent of the total net increase. Over the same period, however, Bamberg, Barnwell, and Richmond Counties experienced net outmigration.

In 1992 the estimated median age of the population in the region was 31.8 years, an estimated 13-percent increase from 1980, although median ages in the region are generally lower than those of the nation and the two states. The region had slightly higher percentages of persons in younger age groups (under 5 and 5 to 19) than the United States, while for all other age groups, the region was comparable to U.S. percentages. The only exception to this was Columbia County, with only 6 percent of its population 65 years or older while the other counties and the United States were 10 percent or greater in this age group.

Population projections indicate that the overall population in the region should continue to grow until about 2040. Three counties -- Allendale, Bamberg, and Barnwell -- should experience little growth after 2000, while the others should increase consistently (see Table 3-18).

Columbia County will continue to show a significant upward growth pattern. The proportion of persons younger than 20 should continue to decrease, while the proportion of persons older than 64 should increase.

### 3.5.2.2 Social Services and Institutions

**Emergency Services.** The six-county region has 50 fire departments, 20 of which are classified as municipal departments with 564 paid staff and 1,100 volunteer personnel. Some of the municipal departments also serve rural areas outside their municipal limits.

Emergency medical and ambulance service in the six counties is not uniformly associated with the fire departments, although rescue squads and ambulance services often house their equipment in fire stations. The six-county region has 19 ambulance and rescue units (9 county or city and 10 private). In 1996 these units had 333 paid full-time, 119 part-time, and 249 volunteer medical personnel who operated 85 ambulance and rescue vehicles and a variety of other trucks and equipment.

Table 3-18. Population projections and percent of region of influence.<sup>a</sup>

Jurisdiction	2000		2010		2020	
	Population	% ROI	Population	% ROI	Population	% ROI
South Carolina						
Aiken County	133,760	26.8	145,798	26.3	156,587	26.2
Allendale County	12,965	2.6	14,131	2.6	15,177	2.5
Bamberg County	18,694	3.8	20,376	3.7	21,884	3.7
Barnwell County	22,444	4.5	24,464	4.4	26,274	4.4
Georgia						
Columbia County	80,294	16.1	90,009	16.3	97,390	16.3
Richmond County	230,698	46.2	258,613	46.7	279,819	46.9
Six-county total	498,854	100	553,391	100	597,091	100

Jurisdiction	2030		2040	
	Population	% ROI	Population	% ROI
South Carolina				
Aiken County	168,175	26.2	180,619	26.1
Allendale County	16,300	2.5	17,506	2.5
Bamberg County	23,503	3.7	25,243	3.6
Barnwell County	28,219	4.4	30,307	4.4
Georgia				
Columbia County	105,376	16.4	114,017	16.5
Richmond County	300,526	46.8	325,169	46.9
Six-county total	642,099	100	692,861	100

a. Source: HNUS (1997).

County sheriff departments and municipal police departments provide most law enforcement services in the region. State law enforcement agents and state troopers assigned to each county provide additional protection. There are 26 county and municipal law enforcement departments in the region with 976 full-time officers (1992 data) and 788 detention facility beds. The region has fewer officers than the South Carolina and Georgia state averages, but it also has a lower crime rate than the states as a whole.

**Health Care.** Eight hospitals that serve the general public plus two military hospitals operate in the six-county region. In 1993 these hospitals had a combined bed capacity of 3,754. There were 5.2 licensed beds per 1,000 population, higher than either of the two states and the United States. The region had a combined nursing home capacity of 2,208 beds, and three

mental health facilities provided a total capacity of 342 beds. Current data on physicians and nurses indicate the region has higher ratios than either of the two states or the United States. There are 3 physicians per 1,000 population compared to 1.7, 1.8, and 2.4 for South Carolina, Georgia, and the United States, respectively.

### 3.5.2.3 Educational Services

In 1995, there were 110 elementary and middle schools, 24 high schools, and 16 post-secondary institutions in the region. In addition, 46 private schools serve 5.5 percent of the student population. The average number of elementary and middle school students per teacher ranged from a low of 14 in Allendale County to a high of 18 in Aiken and Columbia Counties. High school students per teacher ranged from a low of 13 in Allendale County to a high of 21 in

Aiken County. Recent data on school capacities indicate that Aiken County and parts of Barnwell County are over the South Carolina state average of 16.2; parts of the Columbia County system are operating over capacity including all middle schools, one elementary school, and three high schools. Richmond County schools are also generally over capacity; the county is in a 4-year construction program to build several new schools: one high school, one middle school, and four or five elementary schools.

#### 3.5.2.4 Environmental Justice

In 1995 DOE completed an analysis of the economic and racial characteristics of the population in areas affected by SRS operations for the *Environmental Impact Statement, Interim Management of Nuclear Materials* (DOE 1995d). That EIS evaluated whether minority communities or low income communities could receive disproportionately high and adverse human health and environmental impacts. Geographically, it examined the population within a 50-mile (80-kilometer) radius plus areas downstream of the Site that withdraw drinking water from the Savannah River. The area encompasses a total of 147 census tracts, resulting in a total affected population of 993,667. Of that population, 618,000 (62 percent) are white. In the minority population, approximately 94 percent are African American; the remainder consists of small percentages of Asian, Hispanic, and Native American persons (see Table 3-19).

The analysis determined that, of the 147 census tracts in the combined region, 80 contain populations of 50 percent or more minorities. An additional 50 tracts contain between 35 and 50 percent minorities. These tracts are well distributed throughout the region, although there are more of them toward the south and in the immediate vicinities of Augusta and Savannah (see Figure 3-18).

Low income communities [25 percent or more of the population as living in poverty (i.e., income of \$8,076 for a family of two)] occur in 72 census tracts distributed throughout the region of interest, but primarily to the south and west

of the SRS (see Figure 3-19). This represents more than 169,000 persons or about 17 percent of the total population (see Table 3-20).

### 3.5.3 PROJECTED ECONOMIC AND POPULATION CONDITIONS

This section establishes the projected economic and population baseline for the No action alternative. The No action alternative assumes no new missions at the Savannah River Site and a leveling of the workforce at approximately 10,000 by 2001. To show the regional effects of the changed workforce for the No action alternative, a simulation using the Regional Economic Models, Inc. Economic-Demographic Forecasting and Simulation 53-Sector Model (REMI EDF5-53) was run (REMI 1996). The regional model provides control and simulation forecasts through 2035 for the eight-county region under review. These counties are Aiken, Allendale, Bamberg, Barnwell, and Edgefield in South Carolina, and Burke, Columbia, and Richmond in Georgia. REMI uses Bureau of Economic Analysis regional employment, wage, and personal income data, supplemented by Bureau of Labor Statistics (BLS) and County Business Pattern data to establish historical tables which are the basis for the control forecasts. Control economic projections are primarily based on BLS moderate growth benchmark projections. BLS labor force and Census Bureau projections are used to project labor force. Occupational data are from BLS, and population data and projections are from the Census Bureau.

Recently, Bridgestone-Firestone, Inc. announced plans to construct and operate a \$435 million tire factory in Aiken County, employing 800 when in full operation. However, there has been no attempt in either this projection or the Chapter 4 impacts analyses to factor in this or other expected or potential changes in regional employment except as described based on the SRS scenarios. This will allow the APT EIS to focus on a comparison of the APT alternatives. Impacts of the Bridgestone factory will be discussed in the cumulative impacts section.



**Table 3-19.** General racial characteristics of population in the Savannah River Site region of interest.

State	Total population	White	Minorities	African American	Hispanic	Asian	Native American	Other	Percent Minorities <sup>a</sup>
South Carolina ROI	418,685	267,639	151,046	144,147	3,899	1,734	911	355	36.1%
Georgia ROI	<u>574,982</u>	<u>350,233</u>	<u>224,749</u>	<u>208,017</u>	<u>7,245</u>	<u>7,463</u>	<u>1,546</u>	<u>478</u>	<u>39.1%</u>
Total	993,667	617,872	375,795	352,164	11,144	9,197	2,457	833	37.8%

<sup>a</sup> Minorities population divided by total population.

In the short term, total regional employment for the No action alternative would be expected to fall and in year 2 of the analysis regional employment would be down by more than 2,600 from current levels. However, after the second year of the analysis, regional employment would again begin to increase, returning to current levels in year 5. After that time, regional employment would continue to grow at rates consistent with historic regional trends. Figure 3-20 shows the projected total regional employment for the no action alternative.

The annual rate of regional population growth under the No action alternative for the first 4 years of the analysis would be approximately 60 percent of the rate of growth for the 4 years prior to the period of analysis, slowing from 1.0 to 0.6 percent per year. After that period, the rate of annual growth would be expected to return to rates of approximately 0.8 percent for the analysis period of 10 to 20 years. Figure 3-21 shows the projected population for the no action alternative.

Total regional personal income (annual) under the No action alternative would continue to grow, although at a slower pace during the early years of the analysis than during the years immediately preceding the analysis period. During years 1 to 4 of the analysis, total personal income would be expected to increase by approximately \$600 million dollars, an annual increase of 1.4 percent, in contrast to the annualized increases of 2.7 percent for the 4 years prior to the analysis period.

Gross Regional Product (GRP, analogous to Gross Domestic Product) under the No action

alternative would decrease slightly from current levels by approximately 0.54 percent, \$70 million dollars (1996 dollars), in year 1 of the analysis, although it would begin to grow again in year 2. The annual growth rate for the 4 years immediately prior to the analysis period was approximately 2.1 percent, although the rate had slowed to less than 1.4 percent in the last year. In the long run, the GRP would be expected to stabilize at approximately 1.3 percent annual growth.

For the analysis period years 1 through 4, the annual rate of growth for state and local government expenditures will be approximately 1.4 percent, a decrease from approximately 2.4 percent from the prior four year period. In the longer run, it is expected that the annual rate of government expenditures will increase by approximately 1.8 percent over the first 10 years of the analysis before leveling at growth rates of less than 1.5 percent after that.

Under the No Action alternative, the regional economy and population will grow at a reduced rate from recent years.

Figure 3-22 shows projected personal income, GRP, and state and local government expenditures for the no action alternative over the analysis period.

In summary, because the largest influence on regional economies is the national economy (assumed to be growing), it would be expected that after a few years changes in the SRS workforce would be assimilated and the regional economy will return to a steady growth stage.

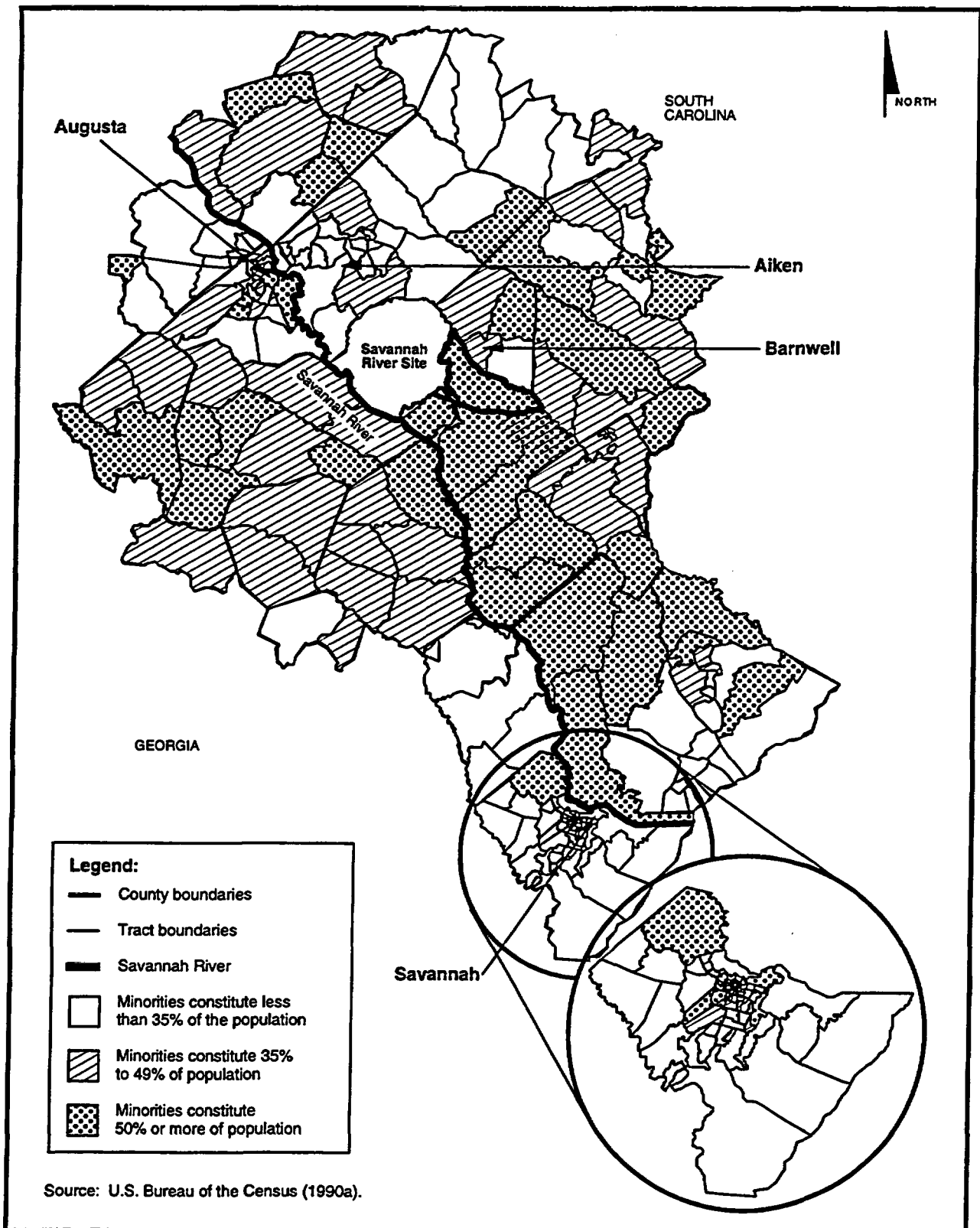

Figure 3-18. Distribution of minority population by census tracts in the SRS region of analysis.

PK68-Z1-PC

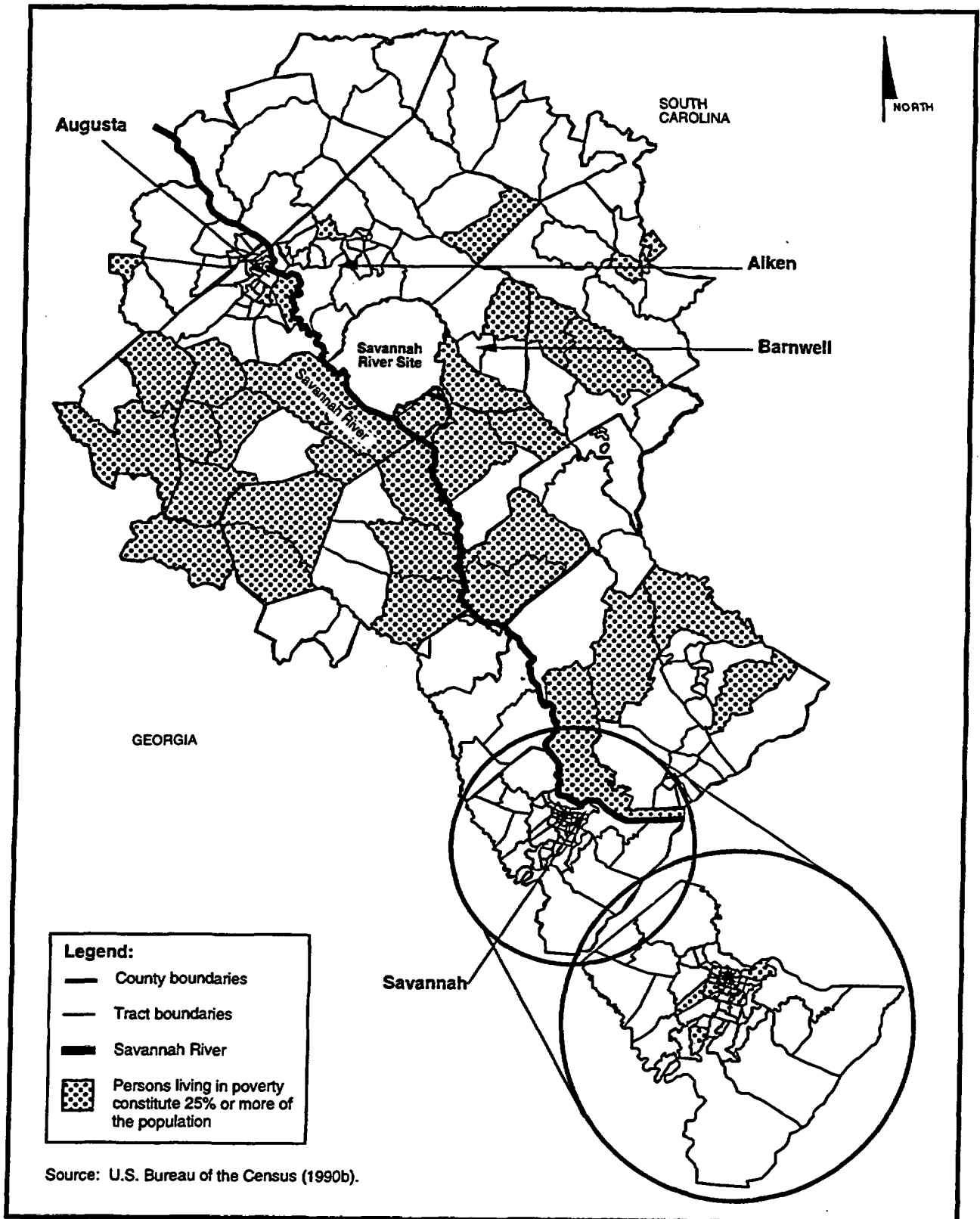

Figure 3-19. Low income census tracts in the SRS region of analysis.

PK68-Z1-PC

**Table 3-20. General poverty characteristics of population in the Savannah River Site region of interest.**

Area	Total population	Persons living in poverty <sup>a</sup>	Percent living in poverty
South Carolina	418,685	72,345	17.3%
Georgia	<u>574,982</u>	<u>96,672</u>	<u>16.8%</u>
Total	993,667	169,017	17.0%

a. Families with income less than the statistical poverty threshold, which in 1990 was 1989 income of \$8,076 for a family of two.

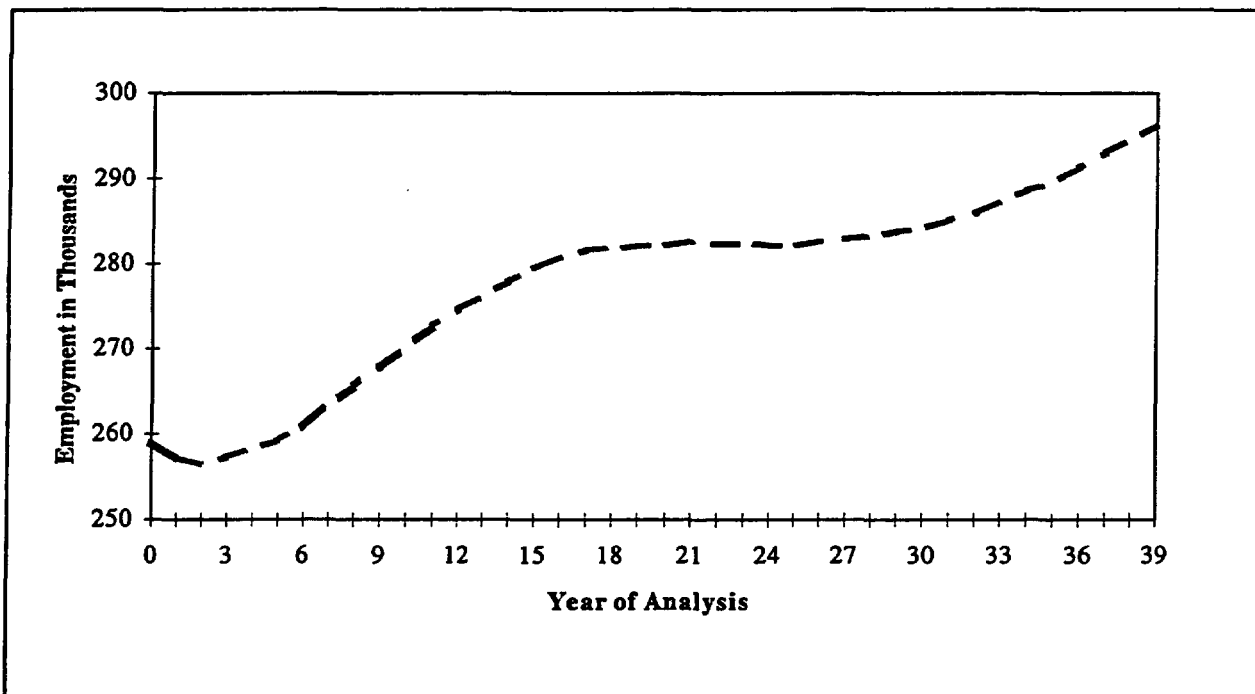

**Figure 3-20. Projected Regional Employment.**

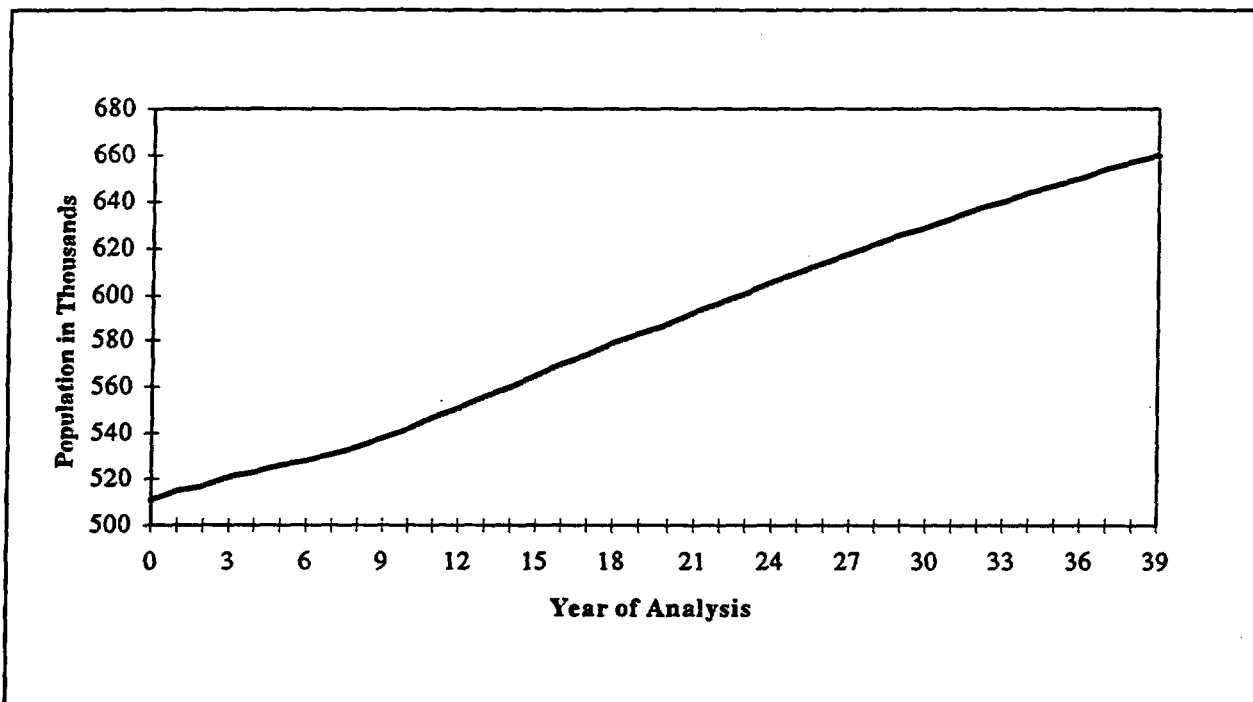

Figure 3-21. Projected Regional Population.

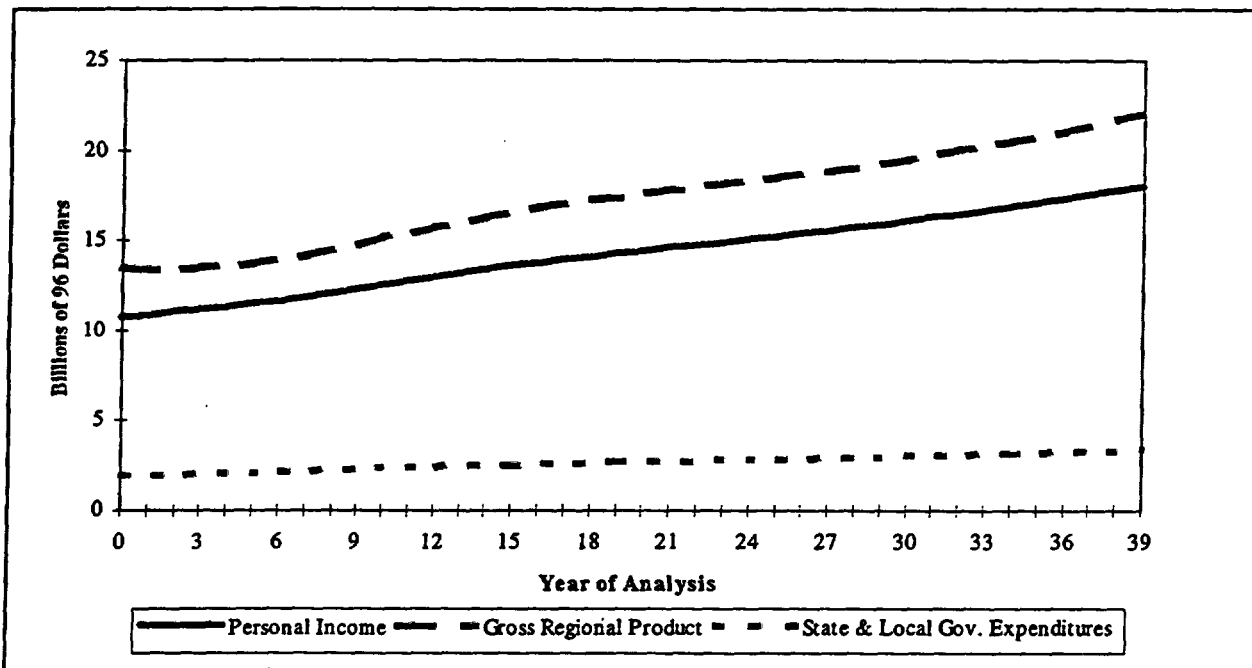

Figure 3-22. Projected Regional Total Personal Income, Gross Regional Product, and State and Local Government Expenditures.

## References

- Aadland, R., J. A. Gellici, and P. A. Thayer, 1995, *Hydrologic Framework for West Central South Carolina*, Water Resources Division Report 5, State of South Carolina, Department of Natural Resources, Columbia, South Carolina.
- Aho, J. M. and C. S. Anderson, 1985, *Fish Populations in Pond C: Dynamics of the Fish Kills (a Preliminary Report)*, SWED-85/1209, Savannah River Ecology Laboratory, Aiken, South Carolina.
- Aho, J. M., C. S. Anderson, and J. W. Terrell, 1986, *Habitat suitability index models and instream flow suitability curves: redbreast sunfish*, U.S. Fish and Wildlife Service, Fort Collins, Colorado.
- Arnett, M. W., 1996, *Savannah River Site Environmental Data for 1995*, WSRC-TR-96-0077, Westinghouse Savannah River Company, Savannah River Site, Aiken, South Carolina.
- Arnett, M. W., L. K. Karapatakis, and A. R. Marnatey, 1993, *Savannah River Environmental Report for 1992*, WSRC-TR-93-075, Westinghouse Savannah River Company, Aiken, South Carolina.
- Arnett, M. W., and A. R. Marnatey, 1996, *Savannah River Site Environmental Report for 1995*, WSRC-TR-96-0075, Westinghouse Savannah River Company, Savannah River Site, Aiken, South Carolina.
- Batson, W. T., J. S. Angerman, and J. T. Jones, 1985, *Flora of the Savannah River Plant: An Inventory of the Vascular Plants on the Savannah River Plant, South Carolina*, Savannah River Plant National Environmental Research Park Program, Aiken, South Carolina.
- Bennett, D. H. and R. W. McFarlane, 1983, *The Fishes of the Savannah River Plant: National Environmental Research Park*, SRO-NERP-12, Savannah River Ecology Laboratory, Aiken, South Carolina.
- Bollinger, G. A., 1973, *Seismicity of the Southeastern United States*, *Bulletin of the Seismological Society of America*, Volume 63, No. 5, pp. 1785-1808.
- Brooks, F., 1994, "Bald Eagle Nests on the Savannah River Site," personal communication with R. K. Abernethy (Halliburton NUS Corporation), Aiken, South Carolina.
- Brooks, M. J., G. T. Hanson, and R. D. Brooks, 1986, *An Intensive Archaeological Survey and Testing of Alternative, New Low-Level Radioactive and Hazardous/Mixed Waste Storage/Disposal Facilities, Savannah River Plant, Aiken and Barnwell Counties, South Carolina*, manuscript on file with the Savannah River Archaeological Research Program, South Carolina Institute of Archaeology and Anthropology, University of South Carolina, Columbia, South Carolina.
- Brooks, R. D., 1996, "Archeological and Cultural Resources Associated with Proposed APT Sites," personal communication with Y. F. Abernethy (Halliburton NUS Corporation), Savannah River Archaeological Research Program, South Carolina Institute of Archaeology and Anthropology, University of South Carolina, Columbia, South Carolina.
- Bryan, A. L., 1992, "Recent Work with Natural Resource Trusteeship concerning Wood Storks," personal communication with R. K. Abernethy (Halliburton NUS Corporation), Savannah River Ecology Laboratory, Aiken, South Carolina.

- Bryan, A. L., T. M. Murphy, K. L. Bildstein, I. L. Brisbin, and J. J. Mayer, 1996, "Use of Reservoirs and Other Artificial Impoundments by Bald Eagles in South Carolina," in D. M. Bird (ed.), *Raptors in Human Landscapes*, Academic Press, London, England, pp. 287-298.
- Bureau of Labor Statistics, 1995, *Survey of Occupational Injuries and Illnesses*, U.S. Department of Labor, Washington, D.C.
- CDC (Center for Disease Control and Prevention), 1993, *Monthly Vital Statistics Report*, Volume 1, No. 7, Supplement, January 7, 1993, *Advance Report of Final Mortality Statistics*, 1990, U.S. Public Health Service, Department of Health and Human Services, Washington, D.C.
- Chimney, M. J., W. R., Cody, and W. M. Starkel, 1985, *Final Report on the Water Quality, Phytoplankton, and Zooplankton of Par Pond and Pond B: January 1984 - June 1985*, Volumes I, II, III, DPST-85-789, prepared by Environmental and Chemical Sciences, Inc., for Savannah River Laboratory, E. I. du Pont de Nemours & Company, Savannah River Plant, Aiken, South Carolina.
- Cooney, T. W., K. H. Jones, P. A. Drewes, J. W. Gissendanner, and B. W. Church, 1995, *Water Resources Data South Carolina Water Year 1995*, USGS-WDR-SC-95-1, U.S. Geological Survey, Water Resources Division, Columbia, South Carolina.
- Cooney, T. W., 1996, *Water Resources Data South Carolina Water Year 1996*, USGS-WDR-SC-96-1, U.S. Geological Survey, Water Resources Division, Columbia, South Carolina.
- Cothran, E. G., M. H. Smith, J. O. Wolff, and J. B. Gentry, 1991, *Mammals of the Savannah River Site*, SRO-NERP-21, Savannah River Ecology Laboratory, Aiken, South Carolina.
- Dames & Moore, 1992, *Ichthyoplankton Entrainment Study at the SRS Savannah River Water Intakes*, WSRC-TR-92-179, Westinghouse Savannah River Company, Savannah River Site, Aiken, South Carolina.
- Davis, G. M. and M. Mulvey, 1993, *Species Status of Mill Creek Elliptio*, SRO-NERP-22, Savannah River Site National Environmental Research Park, Savannah River Ecology Laboratory, Aiken, South Carolina.
- DOE (U.S. Department of Energy), 1984, *Final Environmental Impact Statement, L-Reactors Operation, Savannah River Plant, Aiken, South Carolina*, DOE/EIS-0180, Savannah River Operations Office, Aiken, South Carolina.
- DOE (U.S. Department of Energy), 1987, *Final Environmental Impact Statement, Waste Management Activities for Groundwater Protection, Savannah River Plant, Aiken, South Carolina*, DOE/EIS-0120, Savannah River Operations Office, Aiken, South Carolina.
- DOE (U.S. Department of Energy), 1990, *Final Environmental Impact Statement, Continued Operation of K-, L-, and P-Reactors*, DOE/EIS-0147, Savannah River Operations Office, Aiken, South Carolina.
- DOE (U.S. Department of Energy), 1993, *Introduction to Natural Resources Management at the Savannah River Site*, Savannah River Operations Office, Aiken, South Carolina.
- DOE (U.S. Department of Energy), 1995a, *Environmental Assessment for the Natural Fluctuation of Water Level in Par Pond and Reduced Water Flow in Steel Creek Below L-Lake at the Savannah River Site* (DOE-EA-1070), U.S. Department of Energy, Savannah River Operations Office, Savannah River Site.

- DOE (U.S. Department of Energy), 1995b, *Final Savannah River Site Waste Management Environmental Impact Statement*, DOE/EIS-0217, Savannah River Operations Office, Aiken, South Carolina.
- DOE (U.S. Department of Energy), 1995c, *Environmental Assessment for the Construction and Operation of the Three Rivers Solid Waste Authority, Regional Waste Management Center at the Savannah River Site*, DOE/EA-1079, Savannah River Operations Office, Aiken, South Carolina.
- DOE (U.S. Department of Energy), 1995d, *Environmental Impact Statement, Interim Management of Nuclear Materials*, DOE/EIS-0220, Savannah River Operations Office, Aiken, South Carolina.
- DOE (U.S. Department of Energy), 1997, *Final Environmental Impact Statement, Shutdown of the River Water System at the Savannah River Site*, DOE/EIS-0268D, Savannah River Operations Office, Aiken, South Carolina.
- du Pont (E. I. du Pont de Nemours and Company, Inc.), 1987, *Comprehensive Cooling Water Study - Final Report*, Volumes I-VIII, DP-1739, Savannah River Plant, Aiken, South Carolina.
- du Pont (E. I. du Pont de Nemours and Company, Inc.), 1989, *Radiation Exposure Report, Annual Report for 1988*, DPSPU-89-11-1, Savannah River Plant, Aiken, South Carolina.
- EPA (U.S. Environmental Protection Agency), 1992, *Industrial Source Complex (ISC) Dispersion Model User's Guide*, Second Edition (Revised), Volume 1, II, National Technical Information Service, Springfield, Virginia.
- Fridell, J., 1997, "Status of Sandburrowing Mayfly," personal communication with Y. F. Abernethy (Halliburton NUS Corporation), U.S. Fish and Wildlife Service, Asheville, North Carolina, October 7.
- FWS (Fish and Wildlife Service), 1995, *Smooth Coneflower Recovery Plan*, Southeast Region (Region IV) Atlanta, Georgia.
- Gibbons, J. W. and K. K. Patterson, 1978, *The Reptiles and Amphibians of the Savannah River Plant*, SRO-NERP-2, Savannah River Ecology Laboratory, Aiken, South Carolina.
- Gibbons, J. W., and R. D. Semlitsch, 1991, *Guide to the Reptiles and Amphibians of the Savannah River Site*, University of Georgia Press, Athens, Georgia.
- Hiergesell, R., 1997, Interoffice memorandum to B. Shedrow, Westinghouse Savannah River Company, Aiken, South Carolina, September 19.
- HNUS (Halliburton NUS Corporation), 1997, *Socioeconomic Characteristics of Selected Counties and Communities Adjacent to the Savannah River Site*, prepared for the U.S. Department of Energy, Savannah River Operations Office, Aiken, South Carolina.
- Hunter, C. H., 1990, *A Climatological Description of the Savannah River Site*, WSRC-RP-89-313, Westinghouse Savannah River Company, Savannah River Site, Aiken, South Carolina.
- Hunter, C. H. and J. Stewart, 1994, *Air Quality Calculations for DWPF Supplemental Environmental Impact Statement*, SRT-ETS-940891, Westinghouse Savannah River Company, Savannah River Site, Aiken, South Carolina.



- Imm, D. W., 1997, *Threatened, Endangered, and Sensitive Species Listing and Habitat Evaluation of the Proposed APT Project*, Savannah River Institute, New Ellenton, South Carolina.
- Kennemore, D. E., 1997, "Site Investigation of Ponds 2, 5, and C," Halliburton NUS Corporation, Aiken, South Carolina, July.
- Kirkman, L. K., R. F. Lide, G. Wein, and R. R. Sharitz, 1996, Vegetation Changes and Land Use Legacies of Depression Wetlands of the Western Coastal Plain of South Carolina, 1951-1992 Wetlands, Volume 16, Number 4, pages 564-576.
- Koch II, J. W., F. D. Martin, and G. P. Friday, 1996, *Results of Submerged Sediment Core Sampling and Analysis on Par Pond, Pond C, and L-Lake. July 1995* (U), Draft WSRC-TR-96-0238, Westinghouse Savannah River Company, Aiken, South Carolina.
- LeMaster, E. T., 1994, "Location of a Second Colony of Smooth Coneflower," personal communication with R. K. Abernethy (Halliburton NUS Corporation), Aiken, South Carolina.
- LeMaster, E. T., 1996, *Biological Assessment - Shutdown of the River Water System at the Savannah River Site*, U.S. Department of Agriculture, Forest Service, Savannah River Forest Station, Aiken, South Carolina, August.
- LeMaster, E. T., 1997, "Red-cockaded Woodpecker Survey," personal communication with Y. F. Abernethy (Halliburton NUS Corporation), Aiken, South Carolina.
- Marcy, B. C., J. A. Bowers, J. B. Gladden, H. M. Hickey, M. P. Jones, E. A. Mackey, J. J. Mayer, and A. C. Doswell, 1994, *Remediation of a Large Contaminated Reactor Cooling Reservoir: Resolving an Environmental/Regulatory Paradox*. From proceedings of a National Association of Environmental Professionals conference held June 12-15, 1994 in New Orleans, Louisiana.
- Mayer, J. J., R. A. Kennamer, and R. T. Hoppe, 1986, *Bald and Golden Eagles of the SRP*, SREL-21. Savannah River Ecology Laboratory, Aiken, South Carolina.
- Mclain, R., 1997, personal communication to P. F. Wise (Halliburton NUS Corporation), U.S. Department of Energy, Savannah River Operations Office, Aiken, South Carolina.
- Murphy, T. M., 1981, *The Population Status of the American Alligator on the Savannah River Plant, South Carolina*, SRO-NERP-4, Savannah River Ecology Laboratory, Aiken, South Carolina.
- Myers, P., 1997, "Prescribed Burning Program at SRS," personal communication to Y. F. Abernethy (Halliburton NUS Corporation), Savannah River Institute, New Ellenton, South Carolina.
- NCRP (National Council on Radiation Protection and Measurements), 1987a, *Ionizing Radiation Exposure to the Population of the United States*, Report No. 93, Washington, D.C.
- NCRP (National Council on Radiation Protection and Measurements), 1987b, *Exposure of the Population in the United States and Canada from Natural Background Radiation*, Report No. 94, Washington, D.C.
- NCRP (National Council on Radiation Protection and Measurements), 1993, *Limitation of Exposure to Ionizing Radiation*, Report Number 116, Washington, D.C.

- Newman, M. C., and A. Messier, 1994, *Mercury Bioaccumulation in Mosquitofish (Gambusia holbrooki) Sampled On and Around the Savannah River Site*, Savannah River Ecology Laboratory, Aiken, South Carolina.
- NRC (U.S. Nuclear Regulatory Commission), 1996, *Dose Commitments Due to Radioactive Releases from Nuclear Power Plant Sites in 1992*, NUREG KR-2850, Volume 14, Washington, D.C.
- NUS (NUS Corporation), 1991a, *American Indian Religious Freedom Act Compliance at the Savannah River Site*, Aiken, South Carolina.
- NUS (NUS Corporation), 1991b, *Air Quality, Cooling Tower, and Noise Impact Analyses in Support of the New Production Reactor Environmental Impact Statement*, Aiken, South Carolina.
- Olson, R. L., 1993, *Risk of Failure of the Par Pond Dam*, Rev. 1 (U), WSRC-RP-92-1355, Westinghouse Savannah River Company, Savannah River Site, Aiken, South Carolina.
- Paller, M. H., 1994, *Stream Fisheries Characterization Study*, WSRC-TR-94-0123, Westinghouse Savannah River Company, Savannah River Site, Aiken, South Carolina.
- Paller, M. H. and L. D. Wike, 1996, *Par Pond Fish, Water, and Sediment Chemistry*, WSRC-TR-96-0208, Revision 1, Westinghouse Savannah River Company, Savannah River Site, Aiken, South Carolina.
- Patrick, R., J. Cairns, Jr., and S. S. Roback, 1967, "An ecosystematic study of the fauna and flora of the Savannah River Plant," *Proceedings of the Academy of Natural Sciences of Philadelphia*, Volume 118, Number 5, pp. 109-407.
- Petty, K. R., 1993, "Health Protection Department 1992 Annual Report," interoffice memorandum to Distribution, Westinghouse Savannah River Company, WSRC-ESH-HPD-9200-035, Aiken, South Carolina.
- REMI, 1996, *Economic Demographic Forecasting and Simulation 53-Sector Model*, Regional Economic Models, Inc., Amherst, Massachusetts.
- Saban, C. L., 1997, interoffice memorandum to W. Craig, "SRS Occupational Injured Illness Trending Data," Halliburton NUS Corporation, Aiken, South Carolina, September 12.
- Sassaman, K., 1997, memorandum to B. Shedrow (Westinghouse Savannah River Company), Savannah River Archaeological Research Program, South Carolina Institute of Archaeology and Anthropology, University of South Carolina.
- SCDHEC (South Carolina Department of Health and Environmental Control), 1976, *Air Pollution Control Regulations and Standards, South Carolina Code of Laws*, Regulations 61-62, Columbia, South Carolina.
- SCDHEC (South Carolina Department of Health and Environmental Control), 1995, *South Carolina Nuclear Facility Environmental Radiation Monitoring-1995 Annual Report*, Division of Radiological Environmental Monitoring, Bureau of Environmental Quality Control Labs, Columbia, South Carolina.
- SCE&G (South Carolina Electric and Gas Company), 1995, *Environmental Assessment for Cope Power Plant*, Volume 1, Columbia, South Carolina.

- Schalles, J. F., R. R. Sharitz, J. W. Gibbons, G. J. Leversee, and J. N. Knox, 1989, *Carolina Bays of the Savannah River Plant*, SRO-NERP-18, Savannah River Ecology Laboratory, Aiken, South Carolina.
- Shedrow, B. C., 1993, *Savannah River Site Affected Environment*, WSRC-TR-93-667, Westinghouse Savannah River Company, Savannah River Site, Aiken, South Carolina.
- Shedrow, B. C., 1997, *Submittal of Technical Data for Preparation of APT EIS*, ESH-EAP-97-0082, Westinghouse Savannah River Company, Aiken, South Carolina.
- Sowers, G. B., and G. F. Sowers, 1961, *Introductory Soil Mechanics and Foundations*, Second Edition, The Macmillan Company, New York, New York.
- SRFS (Savannah River Forest Station), 1997, base maps for Timber Compartments 51 and 52, U.S. Forest Service, New Ellenton, South Carolina.
- Stephenson, D. E., and A. L. Stieve, 1992, *Structural Model of the Basement in the Central Savannah Area, South Carolina and Georgia*, WSRC-TR-92-120, Westinghouse Savannah River Company, Savannah River Site, Aiken, South Carolina.
- URS/Blume (URS/Blume and Associates Engineers), 1982, *Update of Seismic Criteria for the Savannah River Plant*, Volume 1: *Geotechnical*, DPE-3699, prepared for E. I. du Pont de Nemours and Company, Inc., Aiken, South Carolina.
- U.S. Bureau of the Census, 1990a, Summary Tape File 1B, Table P8, Washington, D.C.
- U.S. Bureau of the Census, 1990b, Summary Tape File 1B, Table 117, Washington, D.C.
- USDA (U. S. Department of Agriculture), 1988, *Eagle Bay Management Plan*, Savannah River Forest Station, New Ellenton, South Carolina.
- USDA (United States Department of Agriculture), 1990, *Soil Survey of the Savannah River Plant Area, Parts of Aiken, Barnwell, and Allendale Counties, South Carolina*, Soil Conservation Service, Washington, D.C.
- USGS (United States Geological Survey), 1987, *Topographic Map of the Savannah River Plant*, 10-foot contour interval.
- USGS (United States Geological Survey), 1994, Preliminary Geologic Map of the Savannah River Site, Aiken, Allendale, and Barnwell Counties, South Carolina, Columbia, South Carolina.
- Whipple, S. A., L. H. Wellman, and B. J. Good, 1981, *A Classification of Hardwood Old Swamp Forests of the Savannah River Plant, South Carolina*, SRO-NERP-6, Savannah River Ecology Laboratory, Aiken, South Carolina.
- White, C., 1997, "South Carolina Electric and Gas's (SCE&G) power generating at reserve capacity," personal communication with P. Wise (Halliburton NUS Corporation), SCE&G, Columbia, South Carolina, September 10.
- Wike, L. D., R. W. Shipley, A. L. Bryan, Jr., J. A. Bowers, C. L. Cunningham, S. R. del Carmen, G. P. Friday, J. E. Irwin, J. J. Mayer, E. A. Nelson, M. H. Paller, V. A. Roger, W. L. Specht, and E. Wilde, 1994, *Savannah River Site Ecology Environmental Information Document*, WSRC-RP-93-496, Westinghouse Savannah River Company, Savannah River Site, Aiken, South Carolina.

- Wilde, E. W., 1985, *Compliance of the Savannah River Plant P-Reactor Cooling System with Environmental Regulations*, DP-1708, E. I. du Pont de Nemours and Company, Inc., Savannah River Plant, Aiken, South Carolina.
- Wilde, E. W. and L. J. Tilly, 1985, *Influence of P-Reactor Operation on the Aquatic Ecology of Par Pond: A Literature Review*, DP-1698, E. I. du Pont de Nemours and Company, Savannah River Laboratory, Aiken, South Carolina.
- Wilde, E. W., 1987, *Comprehensive Cooling Water Study Final Report, Volume VII, Ecology of Par Pond*, Savannah River Plant, DP-1739-7, E. I. DuPont de Nemars & Company, Savannah River Laboratory, Aiken, South Carolina.
- Workman, S. W. and K. W. McLeod, 1990, *Vegetation of the Savannah River Site, Major Community Types*, SRO-NERP-19, Savannah River Ecology Laboratory, Aiken, South Carolina.
- WSRC (Westinghouse Savannah River Company), 1991a, *Site Hydrologic/Geotechnical Characterization Report for Site B New Municipal Solid Waste Landfill, Savannah River Site*, Volume 1, WSRC-RP-91-392, Savannah River Site, Aiken, South Carolina.
- WSRC (Westinghouse Savannah River Company), 1991b, *Radiation Protection and Industrial Hygiene Annual Report, 1989*, ESH-QIS-910027, Savannah River Site, Aiken, South Carolina.
- WSRC (Westinghouse Savannah River Company), 1992, *1990 Health Protection Annual Report*, ESH-HPD-920072, Savannah River Site, Aiken, South Carolina.
- WSRC (Westinghouse Savannah Company), 1993, *Radiological Control Procedure Manual, 5Q*, Chapter 1, Part 1, Savannah River Site, Aiken, South Carolina.
- WSRC (Westinghouse Savannah River Company), 1994, *Savannah River Site Radiological Performance, 4th Quarter 1993*, ESH-PAS-94-0018, Savannah River Site, Aiken, South Carolina.
- WSRC (Westinghouse Savannah River Company), 1995, *Savannah River Site Radiological Performance, 4th Quarter 1994*, ESH-RCD-95-0016, Savannah River Site, Aiken, South Carolina.
- WSRC (Westinghouse Savannah River Company), 1996a, *Report on Use of Excess M-Area Facilities*, WSRC-SPM-TMD-96-0132, Savannah River Site, Aiken, South Carolina.
- WSRC (Westinghouse Savannah River Company), 1996b, *Site Selection for the Accelerator for Production of Tritium at the Savannah River Site*, WSRC-TR-96-0279, Savannah River Site, Aiken, South Carolina.
- WSRC (Westinghouse Savannah River Company), 1996c, *Savannah River Site Radiological Performance, 4th Quarter 1995*, ESH-RCO-96-0002, Savannah River Site, Aiken, South Carolina.
- WSRC (Westinghouse Savannah River Company), 1997, *APT Site 2, Phase 1 Data Summary Report, Revision 0*, Savannah River Site, Aiken, South Carolina.

# Chapter 4

## Environmental Impacts

---

---

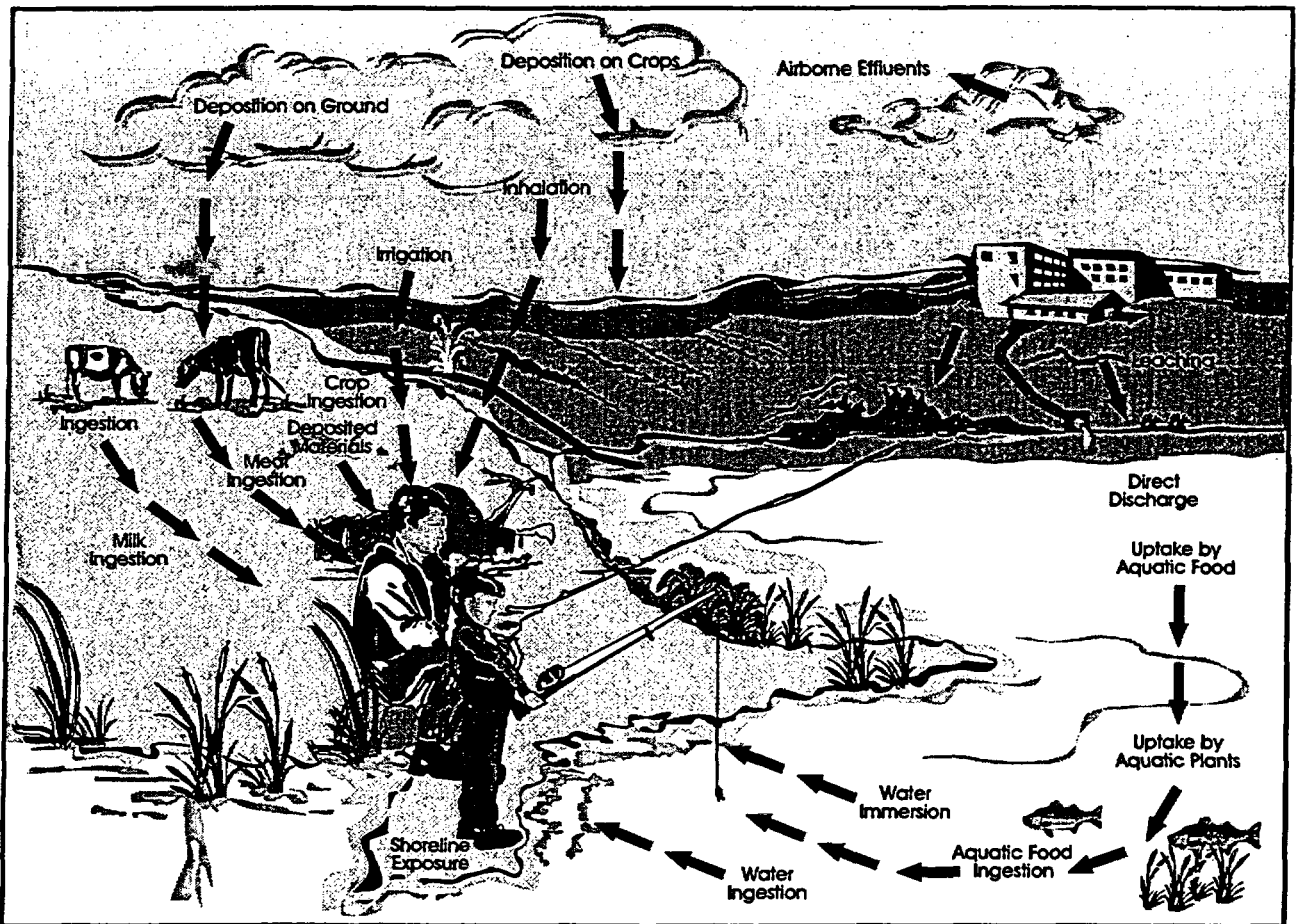

PK68-17PC

Materials released from the SRS reach the environment and people in a number of ways. The routes the materials follow to get from an SRS facility to the environment and then to people are called exposure pathways. A person can take airborne effluents into the body directly by breathing or indirectly due to deposition on crops, followed by ingestion of the crops. Similarly, a person can ingest liquid effluents directly from drinking water or indirectly from food that has absorbed the effluents. Tritium can also be absorbed through the skin.

## CHAPTER 4. ENVIRONMENTAL IMPACTS

This chapter estimates the potential environmental impacts that might occur from the construction and operation of the APT at the Savannah River Site. In general, analyses of potential impacts show that the consequences of the proposed actions would be within established Federal and state guidelines. The potential impacts of each technology alternative are compared to the Preferred APT alternative (Superconducting Operations of Accelerator Structures, Helium-3 Feedstock Material, Mechanical-Draft Cooling Towers with River Water Makeup, construction on a site 3 miles northeast of the Tritium loading facility, and electricity supplied from existing capacity and market transactions). Design variations for the modular accelerator and the extraction facility for Lithium-6 feedstock material within the APT are still being developed. Current estimates indicate the potential environmental impacts associated with these design variations are bounded by the projected impacts for the APT. The modular design variation would require a larger site footprint. Some of the following sections in this chapter have text boxes that summarize key differences between the impacts of the alternatives or simply information the reader should note.

The U.S. Department of Energy (DOE) has estimated the impacts of the alternatives described in Chapter 2 above the baseline conditions described in Chapter 3; in other words, the impacts described in this chapter are in addition to those that exist from other operations at the Savannah River Site (SRS). DOE determined these impacts by analyzing the actions it would complete under each alternative; assessing the actions that could have impacts; identifying the nature of the environmental impact; and quantifying (if possible) the magnitude of the impact.

Most actions would occur at the preferred or alternate Accelerator Production of Tritium (APT) site on about 250 acres of land. Should the Department decide to implement the modular design option described in Section 2.5.1, additional land would be required. Prior to expanding the footprint of either APT site, DOE would evaluate adjacent land for the presence of threatened and endangered species, archaeological sites, and other sensitive resources such as wetlands. The primary environmental impacts would occur at the APT site. Smaller impacts could occur as the result of clearing and construction activities in corridors totaling about 30 acres on the SRS that would connect to the Site infrastructure (e.g., existing roads, pipelines, and outfalls). Prior to selection of specific routes, DOE would evaluate the corridors for the presence of threatened and endangered species, archaeological sites, and other sensitive resources, such as wetlands. This envi-

ronmental impact statement (EIS) also discusses potential impacts of providing electricity for the APT through market transactions or the construction of a new electric generating facility in Sections 4.3 (as part of the evaluation of socioeconomic impacts) and 4.4.

In addition to the construction activities described in Chapter 2, DOE could build two temporary facilities -- concrete batch plants and a construction debris landfill. DOE would ultimately use water from existing sources of process water on the SRS to make concrete. The batch plants could be located near the construction site to reduce the amount of construction-related traffic on roads. The construction and operation of the batch plants could result in some land clearing and airborne emissions. DOE would ensure that the batch plants met stringent permit requirements so the impact of operating these plants would not be a substantial contributor to construction-related impacts.

DOE is currently investigating the need for a landfill to receive debris from APT construction activities. The landfill would require the clearing of land. The landfill would comply with SCDHEC landfill requirements.

As in the case of utility corridors, prior to the selection of sites for batch plants and a construction debris landfill, DOE would evaluate the sites for the presence of threatened and en-

dangered species, archaeological sites, and other sensitive resources such as Carolina bays and wetlands.

In addition to constructing and operating the accelerator at the preferred or alternate site, DOE could place support functions in M-Area. Because these activities would involve existing facilities in industrialized areas and the existing SRS transportation infrastructure, DOE believes there would be little or no impact on the environment. DOE does not anticipate impacts to ecological resources, surface water, or their associated wetlands because activities would be confined to developed areas. For APT-related missions in H-Area, the proposed construction and operation of the Tritium Extraction Facility and the upgrade and consolidation of existing Tritium facilities, the Department is preparing a separate EIS and environmental assessment (EA), respectively. However, this APT EIS includes estimated emissions for the proposed Tritium Extraction Facility for the Lithium-6 feedstock alternative.

Should the Department discover threatened, endangered, or other sensitive resources on either potentially affected areas, avoidance or other appropriate mitigation measures would be taken. Likewise, the potential exists that excavation-related activities could result in the discovery of previously unknown and undocumented hazardous, toxic, and/or radioactive material. In the event that any hazardous, toxic, and/or radioactive material were discovered, DOE would remove and dispose of such material in accordance with all applicable laws and regulations.

DOE has not identified any significant cultural resources (see Sections 3.3.5 and 7.1.2) that the APT could affect. However, if DOE discovered such sites during the construction of the accelerator, utility corridors, other infrastructure, or on potential landfill and batch plant sites, it would comply with the stipulations of the Programmatic Memorandum of Agreement (PMOA) between DOE, the South Carolina State Historic Preservation Officer, and the Advisory Council on Historic Preservation.

The PMOA is the instrument for the management of cultural resources at the SRS; DOE uses it to identify cultural resources, assess them in terms of eligibility for the National Register of Historic Places, and develop mitigation plans for affected resources in consultation with the State Historic Preservation Officer.

This chapter presents construction and operation impacts separately; this enables a clear distinction between the one-time impacts associated with construction activities and the recurring impacts associated with routine operations. Where possible, the chapter presents construction impacts as total impacts over the period of construction; in some instances, however, it provides construction impacts on an annual basis to indicate how construction effects would vary by time.

This EIS presents operational impacts on an annual basis. For some resource areas, DOE has estimated quantitative impacts; for these, DOE presents the impacts of the Preferred alternative (i.e., the collection of preferred design elements described in Chapter 2) and then presents the impacts for other alternatives as percentage increases or decreases in relation to the Preferred alternative. This approach enables a comparison of impacts, and enables the decisionmaker to select any combination of alternatives and evaluate the impacts of combining the relative percentage increases or decreases for the selected alternatives. The potential impacts associated with design alternatives (e.g., exchanging room temperature for superconducting as one of the elements of the Preferred alternative) do not change and are independent of the impacts associated with the other elements comprising the Preferred alternative.

## **IMPACTS OF THE NO ACTION ALTERNATIVE**

As discussed in Chapter 2, the No Action alternative would result in the design, but not the construction of the APT facilities. Therefore, the No Action alternative would result in no incremental environmental impacts beyond the current baseline for the SRS. Because DOE



used the existing baseline of impacts from the Site as its basis for discussion in Chapter 3, it believes that the descriptions in Chapter 3 are representative of the impacts of the No Action alternative.

## 4.1 Impacts on the Physical and Manmade Environment

### 4.1.1 LANDFORMS, SOILS, GEOLOGY, AND HYDROLOGY

In its consideration of landforms, soils, geology, and hydrogeology, this EIS evaluates the potential for the construction and operation of the APT facilities to cause the following impacts:

- Erosion of soil
- Changes to the topography
- Reduction or destruction of economically valuable or geologically significant formations
- Depletion of aquifers beyond their capacity to replenish due to the use of wells to supply cooling water to the APT site
- Change in the groundwater flow near the APT site
- Contamination of the aquifers through activation of stable atoms in the soil and groundwater

#### 4.1.1.1 Construction

No known deposits of economic or geologic value occur on either APT site. Changes to landforms would occur during construction activities for the APT, its support facilities, and utilities. These activities would include the excavation of surface and subsurface materials, their possible use as fill for the site, the excavation for APT facilities, and construction of the roads and utility corridors. Construction at either APT site would level the surface topogra-

phy to accommodate the proposed structures. The accelerator tunnel would be bermed.

Because the erosion potential for the soils at either APT site is slight and because DOE would use best management practices and would ensure compliance with Federal and state regulations to ensure that the excavation and placement of soils during construction would limit soil loss, impacts would be minimal.

Construction of the APT could require an excavation about 65 feet deep. At the preferred site, this would reach the water table and thus require dewatering. The potentially affected aquifer is not a source of potable process water. Impacts to the water table would be minimal due to the relatively short period of dewatering and the fact construction would only affect the shallowest portion.

APT operations, however, could result in potentially greater impacts if the groundwater makeup alternative is chosen. The removal of 6,000 gpm on a sustained basis could result in changes or reduction of groundwater flows to some streams surrounding the well field, and compaction of clay layers.

During operations, neutrons would be produced which could penetrate the accelerator's shielding and be absorbed by the soil and groundwater. The accelerator would be designed so that the dose associated with this activity is less than one-eighth of the EPA drinking water standard of 4 millirem.

Conceptual design information indicates that the Target/Blanket Building would be deep enough, approximately 65 feet, in the soil to intersect the water table at the preferred APT site, making it necessary to remove water from the shallowest portion of the aquifer to permit construction. Dewatering over a short period would cause minimal impacts to the aquifer because construction would occur only in the shallowest portion. The potentially affected aquifer is not a source of potable or process water at the SRS. DOE would perform a geotechnical evaluation of the effects of dewa-

tering on the compaction of the soils of the water table aquifer before beginning such activities. At the alternate site the water table is deeper and would require less dewatering than the preferred site. Because DOE would use existing potable water sources by extending water lines to reach the selected APT site, there would be no hydrogeologic impacts from this activity.

DOE does not anticipate using groundwater near the APT site for construction activities (process water, potable water, etc.) under any alternative. Water for construction activities would be brought in by tanker truck or be obtained from existing process water or groundwater sources. However, DOE could install wells near the APT site to supply makeup water for the operation of mechanical-draft cooling towers discussed in the next section.

#### 4.1.1.2 Operations

DOE has identified two actions during operations that could affect geologic resources:

- Extraction of water from wells to supply makeup water for the Mechanical-Draft Cooling Towers with Groundwater Makeup alternative
- Creation of radioactive material in the groundwater due to neutron activation

As discussed in Chapter 2, the Mechanical-Draft Cooling Towers with Groundwater Makeup alternative would require about 6,000 gallons per minute (or 8.6 million gallons per day) of water from multiple wells near the APT site. DOE estimates this would require the drilling of 18 wells, each capable of supplying 500 gallons per minute; thus, 12 wells could supply the necessary 6,000 gallons per minute and 6 could serve as backup water supply. Under this alternative, a central well-field tank would collect water from the wells and supply it to the cooling towers. The APT groundwater makeup water requirements would approach the total current site-wide groundwater withdrawal rate of 9 to 12 million gallons per day (Arnett and Mamatey

1996). Based on two recent estimates, the production capacity of the aquifer ranges from 16 to 25 million gallons per day (WSRC 1996a). If the APT groundwater makeup water requirements (8.6 million gallons per day) are added to the current groundwater use (9 to 12 million gallons per day), total groundwater withdrawals could exceed the estimated production capacity of the aquifer of 16 to 25 million gallons per day. SRS groundwater usage is detailed in Section 3.3.6.

Because of the volume of water required, DOE would drill the wells into the McQueen Branch Aquifer, a deep aquifer which is a source of water for several SRS facilities and could supply the required volumes. The wide placement of the wells pumping at this rate on a temporary basis or on a periodic basis is likely to be minimal to the groundwater flow system. There is less certainty as to the possible long-term impact of continuous pumping at this rate.

Possible impacts to the groundwater flow system that might result from sustaining this extraction rate indefinitely might include the following:

- Sufficient decline in hydraulic heads in the McQueen Branch Aquifer that horizontal flow directions within the sub region surrounding the well field are significantly altered (Hiergesell 1997).
- Propagation of the decline in hydraulic heads in the overlying Crouch Branch and Gordon Aquifers such that: (1) the vertical upward flow direction from the former to the latter is reversed in critical areas. Critical areas are those locations where near-surface contaminant plumes exist; (2) a gradual reduction in baseflow in some streams surrounding the wellfield, and (3) compaction of clay layers comprising the McQueen Branch Confining Unit and the Crouch Branch Confining Unit (Hiergesell 1997).

During accelerator operations, some neutrons could penetrate the accelerator shielding and be

available for absorption by stable (non-radioactive) atoms in the soil and groundwater to form radioactive atoms that groundwater could transport away. The accelerator tunnel and target/blanket building shielding would be designed (Fikani 1997) so that the radiation dose from the calculated Tritium concentration in groundwater, for a hypothetical individual drinking the APT site groundwater continuously throughout the year, would be less than one-eighth of the U.S. Environmental Protection Agency (EPA) drinking water standard of 4 millirem per year. Because more detailed calculations to account for dispersion during movement to a real receptor would produce even lower doses, there would be minimal impacts from the activation of groundwater.

#### 4.1.2 SURFACE WATER RESOURCES

##### 4.1.2.1 Construction

DOE does not expect to withdraw surface water for APT construction. Water for construction activities would be brought in by tanker truck or be obtained from existing groundwater or process water sources. As discussed in Section 4.1.1.1, however, excavation of the APT facilities could require dewatering with possible discharges to nearby surface water streams. Because the water table at the preferred site contributes much of the flow in these streams, the discharge of groundwater from the APT facilities would not alter the constituents of the streams. However, because gross alpha, non-volatile beta, total radium, and Tritium concentrations in groundwater samples from the water-table aquifer sometimes exceed regulatory standards, the South Carolina Department of Health and Environmental Control (SCDHEC) would be consulted to ensure that water from dewatering operations is disposed of in accordance with State regulations. Discharge flows from dewatering operations could produce a temporary increase in levels of suspended solids in surface water streams.

As part of its preparation for construction, DOE would augment its existing sedimentation

and erosion plans, ensuring that they were in compliance with State regulations on stormwater discharges and approved by SCDHEC. After the APT facilities began operation, DOE would include the augmented plans in the SRS *Stormwater Pollution Prevention Plan*. As shown in Figures 3-4 and 3-9, neither the proposed nor the alternate APT site are in the 100-year floodplain.

Operation of the APT would result in thermal discharges from the cooling water system to a series of pre-cooler ponds and ultimately Par Pond. For all cooling water alternatives, except the Once-Through Cooling Water alternative, water temperatures in the receiving water bodies would not exceed 90°F, meeting SCDHEC standards for freshwaters. In the case of the Once-Through Cooling Water alternative, however, discharges to the pre-cooler ponds would be well in excess of 90°F in late summer. Under this scenario, DOE could be required to conduct a Clean Water Act Section 316(a) Demonstration.

Under each cooling water alternative, Cesium-137, trapped in the fine sediments of Par Pond, would be remobilized. The Once-Through Cooling Water alternative would suspend the most Cesium-137. Potential exposures to the public, in either case, would be small.

Potential health impacts associated with water pathways are included in the totals reported in Section 4.2.1.

##### 4.1.2.2 Operations

DOE has identified the following potential sources of impacts on surface water during the operation of the APT facilities:

- Discharge of wastewater containing radiological and nonradiological constituents to onsite surface water bodies that empty into the Savannah River
- Remobilization of radioactive Cesium already in the sediments at outfall locations due to increased water flow

- Removal of large volumes of water from the Savannah River that could disturb the current condition of the river
- Discharge of heated wastewater with non-radioactive constituents to onsite surface water bodies that empty into the Savannah River
- Discharge of volumes of water into surface water bodies that exceed current flows and disturb current conditions

DOE would treat sanitary wastewater from the facilities at the existing treatment plant; the effluents from this plant would continue to meet the requirements of the SRS National Pollutant Discharge Elimination System (NPDES) permits. The APT process wastewater system would treat nonradioactive process wastewater as necessary to meet NPDES requirements.

The APT radioactive liquid waste system would process radioactive wastewater. The average flow rate of the liquid radioactive waste system discharge would be 0.5 gallons per minute, which DOE would combine with other nonradioactive process wastewater before releasing it at the NPDES-permitted outfall from the accelerator (England 1997). The major radionuclides expected to be found in the APT liquid effluent and their respective annual releases are reported in Table 4-1. DOE used the LADTAP XL Computer Code (Simpkins 1997a,b,c) to model the results of this radioactive liquid discharge on downstream receptors, and calculated the dose to the maximally exposed individual (MEI) residing along the Savannah River and to the downstream population; Table 4-2 lists these results. Almost all (99.9 percent) of the dose would be due to the release of Tritium, chiefly from the ingestion of water that is slightly contaminated with Tritium. Because the amount of radioactive liquid releases would not vary much by alternative, the radiation dose from such releases would be essentially the same for all the alternatives.

DOE also calculated concentrations of nonradiological constituents of concern (expressed as total solids and total dissolved solids) that the APT facilities could discharge and lists them in Table 4-2. The cooling water from the APT facilities (either blowdown from cooling towers or discharge from the Once-Through Cooling Using River Water alternative) represents most of the liquid discharges. Small amounts of nonradiological constituents would originate in the APT facilities, but these amounts are negligible in relation to the constituents in the cooling water that are present prior to entering the APT cooling water system. DOE calculated the discharge concentrations based on the constituents in the cooling water taken from the Savannah River. APT cooling tower operations would result in the addition of more material to the water through the concentration of chemicals used to reduce the accumulation of microorganisms in the cooling loops.

Table 4-1. Estimated annual releases (curies) of major radionuclides in liquid discharges from the APT.<sup>a</sup>

Radionuclide	Annual releases <sup>b</sup>
Tritium	1,000
Cobalt-60	0.0001
Chromium-51	0.002
Sodium-22	0.001

a. Source: England (1997).  
b. Annual releases will not change significantly with alternative.

DOE previously identified the presence of Cesium-137 (from R-Reactor operations prior to 1964) in the upper fine sediments of Par Pond, as well as historical releases of Cesium-137 to Pen Branch (DOE 1997a). It is estimated that about 43 curies of Cesium-137 remain in Par Pond, more than two thirds below the 190-foot level (DOE 1997a). DOE has evaluated the potential for the increased water flow associated with the cooling water discharge to agitate the

**Table 4-2. Average annual radiological and nonradiological constituents discharged in liquid effluents for the preferred configuration, and percent differences in alternatives to the Preferred alternative.**

Factor	Results for preferred alternative	Percentage difference of results for alternatives						
		Cooling water system			Accelerator technology	Feedstock Material	Radio-frequency power	Site location
		Once-through cooling using river water	Cooling towers with groundwater makeup	K-Reactor cooling tower with river water makeup	Room temperature	Lithium-6 aluminum alloy	Inductive output tube	Alternate site
Annual MEI <sup>a</sup> dose from radiological discharges	0.0050 millirem	NC <sup>b</sup>	NC	NC	NC	NC	NC	NC
Annual MEI dose from resuspension of contaminated sediments	0.0013 millirem	+6,150% <sup>d</sup>	NC	-60%	NC	NC	NC	NC
Total annual MEI dose from liquid pathways	0.0063 millirem	+940% <sup>c</sup>	NC	-9%	NC	NC	NC	NC
Annual population dose from radiological discharges	0.14 person-rem	NC	NC	NC	NC	NC	NC	NC
Annual population dose from resuspension of contaminated sediments	0.0035 person-rem	+6,150% <sup>f</sup>	NC	-60%	NC	NC	NC	NC
Total annual population dose from liquid pathways	0.14 person-rem	+104%	NC	NC	NC	NC	NC	NC
Average annual temperature of liquid discharges	70°F	+18°F	NC	NC	NC	NC	NC	NC
Maximum annual temperature of liquid discharges	88°F	+14°F	NC	+1°F	NC	NC	NC	NC
Average annual concentration of total dissolved solids in liquid discharges	190 milligrams per liter	-67%	-99% <sup>c</sup>	NC	NC	NC	NC	NC
Average annual concentration of total solids in liquid discharges	220 milligrams per liter	-67%	-99%	NC	NC	NC	NC	NC

a. MEI - maximally exposed individual.

b. NC = Difference in results between this alternative and the Preferred alternative is less than 5 percent.

c. Results for this alternative are several orders of magnitude less than that for the Preferred alternative, even though the designation "-99%" indicates only two orders of magnitude difference.

d. 0.081 millirem.

e. 0.066 millirem.

f. 0.22 person-rem.

contaminated sediments, resuspending them so that they can be transported to the Savannah River. DOE developed an upper bound estimate of the transport of this radioactive Cesium based on previous DOE studies of Cesium remobilization from thermal discharges in site streams (DOE 1987a). Using the discharge rates corresponding to each alternative, DOE calculated the amount of Cesium-137 likely to be resuspended and estimated the corresponding dose to the MEI and the population downstream of the SRS along the Savannah River. The values reported in Table 4-2 for the dose from this source are the estimates for the early years of operation; subsequent years of operation would result in lower doses as the Cesium is gradually removed from the sediments.

DOE has assessed possible impacts on the Savannah River due to removal of large volumes of water by comparing the net required volumes of river water (representing the differences in flow rate withdrawn from the river and the flow rate discharged back to the river) for the cooling water alternatives that use river water to the current flow rate of the river given in Section 3.3.2. The net volumes of river water removed from

the Savannah River are approximately equal for all alternatives, being 0.1 percent of the river flow at the water intake. The once-through system, although resulting in an equivalent (to the cooling tower systems) net removal of water from the river, will result in approximately 2 percent of the river flow being removed at the water intake (almost all of which is returned further downstream).

Discharges from the cooling water system can affect the temperature, chemical makeup, and flow rate of the surface water bodies that receive them. These impacts would depend on the cooling water system alternative (e.g., Mechanical-Draft Cooling Tower with River Water Makeup) but would not vary much with other alternatives. Table 4-3 lists the monthly average and maximum discharge temperatures for all alternatives. The temperatures from the mechanical towers and the K-Area Cooling Tower would be essentially the same. Discharges from the Once-Through Cooling Using River Water alternative would be substantially warmer than the receiving waters in the Par Pond system. The discharge would flow first into Pond 2, and

Table 4-3. Monthly discharge temperatures (°F).

Month	Mechanical-draft towers <sup>a</sup>		K-Area Cooling Tower <sup>b</sup>		Once-through	
	Average <sup>c</sup>	Maximum <sup>d</sup>	Average <sup>c</sup>	Maximum <sup>d</sup>	Average <sup>e</sup>	Maximum <sup>f</sup>
January	58	65	54	59	75	77
February	60	67	56	65	72	75
March	64	72	62	71	79	85
April	68	76	67	77	84	86
May	74	82	73	83	91	95
June	78	86	78	87	96	99
July	81	88	81	89	100	102
August	81	88	81	89	100	101
September	77	85	77	85	98	101
October	70	79	69	78	94	95
November	65	73	63	72	88	93
December	60	67	57	66	81	83

- a. Calculated by the methods presented in DOE (1987a); applies regardless of makeup water source.  
 b. Calculated using vendor-supplied design curves.  
 c. Using long-term average meteorological data from Augusta, Georgia (NWS 1994).  
 d. Using daily maximum temperature (NWS 1994).  
 e. Average monthly Savannah River (above SRS) temperature from Arnett (1993, 1994, 1995, 1996, and 1997) plus 25°F.  
 f. Maximum monthly Savannah River (above SRS) temperature from Arnett (1993, 1994, 1995, 1996, and 1997) plus 25°F.

then through engineered canals to Pond 5, Pond C, and finally to Par Pond (see Figure 2-5). To better analyze the impacts of the Once-Through Cooling alternative, DOE performed calculations to estimate the temperatures that would be expected in the Par Pond System under this alternative. Table 4-4 lists projected average and maximum temperatures entering these ponds by month for the Once-Through Cooling Using River Water alternative. As can be seen in the table, temperatures would decline as the water moves from Pond 2 to Par Pond.

SCDHEC has established water classifications and water quality standards to "protect classified and existing water uses...and maintain and enhance water quality" in South Carolina (SCDHEC 1992). These standards also serve as a basis for decisionmaking in other water quality program areas, such as NPDES permitting. The State has classified the Savannah River and its tributaries in the area of the SRS as "Freshwaters," which means waters "suitable for fishing and the survival and propagation of a balanced and indigenous community of flora and fauna" (SCDHEC 1992). According to the SCDHEC regulations, the weekly average temperature of lakes or reservoirs classified as "Freshwaters" shall not be increased by more than 5°F above natural conditions or exceed 90°F as a result of the discharge of a heated ef-

fluent unless (1) a new temperature standard is adopted, (2) a portion of the lake or reservoir is designated a "mixing zone," or (3) a Section 316(a) determination has been completed.

As shown in Tables 4-3 and 4-4, heated discharges to the pre-cooler ponds (Ponds 2, 5, and C) could require DOE to conduct a Section 316(a) demonstration. However, based on a previous 316(a) study conducted when P-Reactor was operating and 150-165°F effluent was entering the pre-cooler ponds at a rate of 175,000 gallons per minute (Wilde 1985), DOE believes a new 316(a) demonstration would not be required. Chapter 7 discusses the Clean Water Act, the responsibilities of agencies charged with enforcing the Act, and the Clean Water Act Section 316(a) process.

Table 4-5 shows the monthly total solids (dissolved and suspended) concentrations in the cooling water discharge; either cooling tower type (mechanical-draft or the K-Area Cooling Tower) would operate at three cycles of concentration and, therefore, would have the same discharge concentrations (three times that of the intake water). The once-through system would not concentrate the intake chemical concentrations and, therefore, would discharge at a lower concentration (but higher flow) than the cooling towers.

**Table 4-4. Monthly average and maximum water temperatures in Par Pond system from Once-Through Cooling with River Water Alternative (°F).**

Month	Pond 2		Pond 5		Pond C		Par Pond (main)	
	Average	Maximum	Average	Maximum	Average	Maximum	Average	Maximum
January	75	77	73	75	69	72	60	66
February	72	75	71	74	68	72	61	67
March	79	85	78	84	74	82	68	77
April	84	86	82	86	80	85	74	82
May	91	95	89	94	87	93	82	91
June	96	99	95	98	92	97	88	95
July	100	102	98	101	95	100	90	98
August	100	101	98	100	95	99	90	97
September	98	101	96	99	93	97	86	93
October	93	95	91	93	86	90	78	85
November	88	93	85	90	80	86	70	78
December	82	83	78	81	74	77	63	69

Table 4-5. Monthly solids discharge concentrations (milligrams per liter).

Month	Parameter <sup>b</sup>	Cooling towers <sup>a</sup>		Once through	
		Average	Maximum	Average <sup>c</sup>	Maximum <sup>d</sup>
January	TDS	161	177	54	59
	TS	178	201	61	67
February	TDS	185	255	62	85
	TS	215	270	72	90
March	TDS	178	204	59	68
	TS	209	258	70	86
April	TDS	180	213	60	71
	TS	220	252	73	84
May	TDS	204	273	68	91
	TS	240	294	80	98
June	TDS	235	258	78	86
	TS	267	285	89	95
July	TDS	208	249	69	83
	TS	239	258	80	86
August	TDS	205	252	68	84
	TS	237	288	79	96
September	TDS	180	195	60	65
	TS	207	216	69	72
October	TDS	185	201	62	67
	TS	215	231	72	77
November	TDS	200	225	67	75
	TS	224	246	75	82
December	TDS	157	177	52	59
	TS	182	207	61	69

- a. Three cycles of concentration, river water makeup. If groundwater is used as makeup, these concentrations would be reduced by an order of magnitude. Includes mechanical-draft cooling towers and the K-Area Cooling Tower.
- b. TDS = Total dissolved solids.  
TS = Total solids (dissolved + suspended).
- c. Average measured on Savannah River (above SRS) from Arnett (1993, 1994, 1995, 1996, and 1997).
- d. Maximum measured on Savannah River (above SRS) from Arnett (1993, 1994, 1995, 1996, and 1997).

The blowdown flow from the cooling tower discharges would be about 2,000 gallons per minute (4.5 cubic feet per second) for both the K-Area Cooling Tower and the Mechanical-Draft Cooling alternatives. For the K-Area Cooling Tower alternative, the blowdown would flow to Pen Branch via Indian Grave Branch. The natural flow in Indian Grave Branch is about 10 cubic feet per second; when K-Reactor was operating, the flow was 400 cubic feet per second. The mean flow of Pen Branch downstream of its confluence with Indian Grave Branch was 56 cubic feet per second during water year 1995, about 10 times the projected blowdown flow (Shedrow 1997a).

Cooling water from the mechanical-draft towers would be discharged to Pond 2 and subsequently flow to Ponds 5, C, and Par by man-made conveyances. Since river water inputs stopped in early 1996, rainwater and groundwater seepage have been the only inputs to Ponds 2 and 5 (Pinder 1997; Cooney 1996). The flow summary for the P-Area canal discharging to Pond 2 (the only monitoring station associated with Ponds 2 and 5), for March 1996 through September 1996 indicated a mean discharge of 0.14 cubic feet per second and a seasonal maximum temperature of 81°F (Cooney 1996). Flows from the mechanical-draft cooling towers would increase the mean flow into the receiving



pond 32 fold. The 125,000 gallons per minute discharge associated with the Once-Through Cooling with River Water alternative represents a 280-fold increase in flow to the system.

Discharges resulting from the Mechanical-Draft Cooling Tower alternative or the Once-Through Cooling alternative would eventually flow from Par Pond to Lower Three Runs. If the entire blowdown flow from the Mechanical-Draft Cooling Tower alternative was transmitted to Lower Three Runs, the incremental flow in the creek downstream of Par Pond would represent an increase of less than 10 percent, based on the mean flow in water year 1995 (60 cubic feet per second) (Cooney et al. 1995). The once-through discharge to Par Pond would represent an almost five-fold increase in creek flow for the same water year; when P-Reactor was operating (its operation ended in 1988), the discharge flow to the Par Pond-Lower Three Runs system was about 346 cubic feet per second (Wike et al. 1994).

#### 4.1.3 AIR RESOURCES

DOE has determined that air impacts would arise from two major types of activities: construction and operation of the APT facility. Construction activities would include those actions necessary to prepare land and erect necessary facilities for the alternatives evaluated in this EIS. Routine operations would include normal use of these facilities. This section evaluates air emissions from both construction and routine operations.

DOE based the amounts of air releases on estimates of the projected actions and the operating characteristics of the facilities. Table 4-6 lists by alternative the expected emission sources that DOE identified in its assessment of air quality impacts. The table lists emission sources next to the corresponding alternative and includes the sources that would be present regardless of the alternative.

Air releases for the preferred APT site would be the same as those for the alternate site because construction activities and operating character-

istics of the facilities would be the same. Similarly, the emissions sources listed by alternative in Table 4-6 would apply to the alternate site. Differences in impacts are attributable to the distance to the site boundary; impacts would be slightly greater for the alternate site since it is situated closer to the SRS boundary.

Air emissions for both radiological and non-radiological pollutants would be well below applicable regulatory standards for both the construction and operational phases of the APT. Offsite concentrations would be slightly higher at the alternate site because it is closer to the SRS boundary. If DOE chooses the modular design variation, construction impacts could be spread over a longer period and eventually require the clearing of more land. Tritium would contribute over 99 percent of the offsite dose, but is still well below the 10 millirem dose limit for SRS atmospheric releases.

Potential health impacts associated with air pathways are included in the totals reported in Section 4.2.1.

##### 4.1.3.1 Construction

DOE estimates it would clear about 250 acres of land to construct facilities at the APT site in the Preferred alternative. Construction would take approximately 8 years (10 months of site preparation and 7 years of construction) and would involve the use of heavy equipment such as graders, cranes, and scrapers to clear the land, construct buildings, and develop the infrastructure to support the facilities (e.g., pave roads and install storm drain systems). Particulates in the air, caused by construction activities, settle quickly and pose minimal adverse health effects. At present, the National Ambient Air Quality Standards for total suspended particulates (TSP) are regulated as particulate matter with a diameter of 10 micrometers or less. DOE expects no change in air quality impacts due to construction for the various cooling water system alternatives; the K-Area cooling tower and the River Water System are already in place, while mechanical-draft cooling towers would be prefabricated units requiring minimal site disturbance.

**Table 4-6. Sources of air emissions for the APT project.**

Alternative	Source <sup>a</sup> of air emissions
<b>Cooling Water Alternatives</b>	
Mechanical-Draft Cooling Towers with River Water Makeup	<ul style="list-style-type: none"> <li>• Construction of cooling towers</li> <li>• Drift from cooling towers</li> </ul>
Mechanical-Draft Cooling Towers with Ground Water Makeup	<ul style="list-style-type: none"> <li>• Construction of cooling towers</li> <li>• Drift from cooling towers</li> </ul>
Once-Through Cooling Using River Water	<ul style="list-style-type: none"> <li>• None</li> </ul>
K-Area Cooling Tower (Natural Draft)	<ul style="list-style-type: none"> <li>• Drift from cooling tower</li> </ul>
<b>Operating Temperature Alternatives</b>	
Room Temperature Operation	<ul style="list-style-type: none"> <li>• None</li> </ul>
Superconducting Operation	<ul style="list-style-type: none"> <li>• Construction of Cryogenics Facility</li> <li>• Operation of Cryogenics Facility</li> </ul>
<b>Feedstock Material Alternatives</b>	
Helium-3 Feedstock Material	<ul style="list-style-type: none"> <li>• Construction of Tritium Separation Facility</li> <li>• Operation of Tritium Separation Facility</li> </ul>
Lithium-6 Feedstock Material	<ul style="list-style-type: none"> <li>• None<sup>b</sup></li> </ul>
<b>Electrical Power Alternatives<sup>c</sup></b>	
Power from Existing Sources	<ul style="list-style-type: none"> <li>• Operation of existing power plant</li> </ul>
Construction of a new Electrical Power Station	<ul style="list-style-type: none"> <li>• Construction of new power plant</li> <li>• Operation of new power plant</li> </ul>
Base sources (independent of alternative)	<ul style="list-style-type: none"> <li>• Construction activities at APT site<sup>d</sup></li> <li>• Construction activities in M-Area</li> <li>• Operations in M-Area</li> <li>• Releases from accelerator tunnel</li> <li>• Releases from target/blanket building</li> <li>• Releases from klystron gallery</li> <li>• Releases from beamstop building</li> <li>• Emergency diesel generators</li> </ul>

- a. This table lists only the most notable sources and is not intended to describe each possible emission source from the APT Project.
- b. Under this alternative the proposed Tritium Extraction Facility would recover Tritium from the Lithium/aluminum rods. The construction and operation of that facility is the subject of a separate EIS, which will discuss impacts arising from recovering Tritium from Lithium/aluminum rods. TEF information that pertains to cumulative impacts is also discussed in Chapter 5 of this EIS.
- c. Electric power impacts are discussed in Section 4.4.
- d. Construction in this instance would apply only to facilities not associated with a specific alternative.

In accordance with good dust control practices required by South Carolina regulations (SCDHEC R.62.6), measures will be implemented to control fugitive particulate matter. Best management practices would be used during construction, grading of roads, or clearing of land to minimize airborne dust. During times

when grading activities were not occurring, DOE would ensure the stabilization of bare land by using compaction, vegetation, or spray-on adhesives to reduce the probability for air dispersion. Wet or chemical dust suppressants would reduce fugitive dust emissions by approximately 50 percent (EPA 1985).

The EPA Fugitive Dust Model computer program was used to calculate the fugitive dust impacts from construction activities. DOE based its inputs for the program on estimates related to construction activities taking place, including acreage of land disturbed and number of heavy equipment pieces used (Shedrow 1997b).

Heavy-duty construction equipment (i.e., trucks, scrapers, and other diesel-powered support equipment) would be used for excavation and grading, hauling soil and other debris for disposal, and performing other routine construction activities. Exhaust emissions from these diesel engines would result in releases of sulfur dioxides (SO<sub>2</sub>), oxides of nitrogen (NO<sub>x</sub>) particulate matter, and carbon monoxide (CO). The EPA's Industrial Source Complex Short Term Version 3 (ISCST3) model was used to estimate the air emissions from the operation of these types of equipment.

Maximum concentrations were estimated at the SRS site boundary where members of the public could be exposed (Table 4-7) and at the location of a hypothetical nearby site worker [640 meters downwind (Table 4-8)]. As can be seen in Table 4-7, the concentrations of pollutants at the SRS boundary from construction activities would be low compared to the regulatory limits. Construction impacts would not vary markedly for most of the alternatives because the majority of construction activities would be the same regardless of alternatives. All EPA DHEC regulated pollutants associated with construction activities listed in Table 4-8 are below the established limits.

Because the results listed in Tables 4-7 and 4-8 would be associated solely with construction, they would be temporary and would last only until construction ended. The results listed in the tables also would not occur at the same time as impacts from routine operations. Therefore, effects on the environment would initially be due solely to construction and, after startup, would then be due solely to operations. Until the facility becomes operational, there would be no radiological air emissions attributable to the

APT project; thus, Tables 4-7 and 4-8 list only nonradiological emissions.

As discussed above, air releases for the alternate site for the APT would be the same as those for the preferred site because construction activities would remain the same. Because the proposed APT facilities would not change with location, the same land requirements exist, construction would occur over the same duration, equal volumes of soil would be removed, and all the same construction equipment would be needed as for the Preferred alternative.

Table 4-7 also lists expected concentrations of regulated pollutants at the SRS boundary from construction for the Preferred alternative at the alternate site. The concentrations would be slightly higher in all instances than those for the preferred site but would be well below the SCDHEC standards. Concentrations at the hypothetical SRS worker location would be the same as for the Preferred alternative reported in Table 4-8 since the receptor would be the same distance and direction from the source of emissions.

#### 4.1.3.2 Operations

APT operations will result in the emission of both radiological and nonradiological constituents. To determine the impact on air quality, DOE estimated the emission rates associated with the operation of the APT. This included a consideration of what potential air sources exist and how air would be filtered or treated before being released to the environment.

#### 4.1.3.3 Nonradiological Air Emissions

Maximum ground-level concentrations for nonradiological releases were determined by using the EPA's ISCST3 dispersion model (Hunter 1997) assuming ground level releases. As with construction impacts, maximum concentrations were estimated at the SRS boundary where members of the public could be exposed and at the location of a hypothetical nearby site worker 640 meters downwind. Onsite hourly meteorological

**Table 4-7.** Estimated maximum concentrations (micrograms per cubic meter) of regulated air pollutants at the SRS boundary from construction activities at the preferred APT site.

Air emissions	Averaging time	SCDHEC standard	Results for Preferred alternative	Percentage difference of results for alternatives						
				Cooling water system			Accelerator technology	Feedstock Material	Radiofrequency power	Site location
				Once-through cooling using river water	Cooling towers with groundwater makeup	K-Reactor cooling tower with river water makeup	Room Temperature	Lithium-6 aluminum alloy	Inductive output tube	Alternate site
Total suspended particulates	Annual	75	0.07	NC <sup>a</sup>	NC	NC	NC	NC	NC	+75.0%
Particulate matter (≤10 microns)	24-hour	150	1.2	NC	NC	NC	NC	NC	NC	+59.0%
	Annual	50	0.08	NC	NC	NC	NC	NC	NC	+76.0%
Oxides of sulfur <sup>b</sup>	3-hour	1,300	16	NC	NC	NC	NC	NC	NC	+7.6%
	24-hour	365	2.0	NC	NC	NC	NC	NC	NC	+5.0%
	Annual	80	0.019	NC	NC	NC	NC	NC	NC	NC
Oxides of nitrogen <sup>b</sup>	Annual	100	0.17	NC	NC	NC	NC	NC	NC	NC
Carbon monoxide <sup>b</sup>	1-hour	40,000	180	NC	NC	NC	NC	NC	NC	+7.6%
	8-hour	10,000	23	NC	NC	NC	NC	NC	NC	+8.7%

a. NC = Difference in results between this alternative and the Preferred alternative is less than 5 percent.

b. Source: Hunter 1997.

**Table 4-8. Estimated maximum concentrations (milligrams per cubic meter) of nonradiological air pollutants regulated by OSHA at hypothetical worker location (640 meters) from construction activities at the preferred APT site.**

Air emissions	Averaging time <sup>b</sup>	OSHA standard <sup>b</sup>	Results for Preferred alternative	Percentage difference of results for alternatives						
				Cooling water system			Accelerator technology	Feedstock Material	Radio-frequency power	Site location
				Once-through cooling using river water	Cooling towers with groundwater makeup	K-Reactor cooling tower with river water makeup	Room temperature	Lithium-6 aluminum alloy	Inductive output tube	Alternate site <sup>c</sup>
Oxides of sulfur <sup>a</sup>	8-hour TWA	13	0.05	NC <sup>d</sup>	NC	NC	NC	NC	NC	NC
Total suspended particulates	8-hour TWA	15	0.058	NC	NC	NC	NC	NC	NC	NC
Carbon monoxide <sup>a</sup>	8-hour TWA	55	0.18	NC	NC	NC	NC	NC	NC	NC
Oxides of nitrogen <sup>a</sup>	Ceiling	9	2.6	NC	NC	NC	NC	NC	NC	NC

- a. Source: Hunter 1997.
- b. Air pollutants regulated by OSHA under 29 CFR Part 1910. Averaging values listed are 8-hour time weighted averages (TWA) except for oxides of nitrogen which is a not-to-be exceeded ceiling value. Source: 29 CFR Part 1910.100.
- c. Results at the alternative site do not change from the preferred site since the receptor remains at the same location relative to the APT facility.
- d. NC = Difference in impacts between this alternative and the Preferred alternative is less than 5 percent.

logical data were used for the criteria pollutants and air toxics dispersion calculations.

For the Preferred alternative, nonradiological emissions are expected from the accelerator building, the Target/Blanket Building, the Tritium Separation Facility, and the balance of the plant, including three emergency generators. Nonradiological emissions (tons/year) for routine operations are listed in Table 4-9. The APT facility collectively is expected to emit 24 hours a day, 365 days a year. The three emergency generators are projected to operate less than 250 hours per year each. Expected emission rates from operations are compared to the emission rates listed in SCDHEC Standard 7, Prevention of Significant Deterioration (PSD), to determine if the facility emissions would be considered a significant net emissions increase. Facilities located in attainment areas that have any new or modified sources which exceed the PSD "significant" increase amount are required to obtain a PSD permit prior to construction. However, as can be seen in Table 4-9, all of the expected emissions from the APT facility are well below the PSD significant emission rates.

The maximum air concentrations at the SRS boundary associated with the Preferred alternative are listed in Table 4-10. As the results indicate, all emissions are less than 1 percent of the applicable standards. Most of the pollutants, with the exception of ethyl alcohol and particulate matter (TSP and PM<sub>10</sub>), would result pri-

marily from emissions from the three emergency generators.

Changes in the maximum ground-level concentrations at the SRS boundary would occur only for the Lithium-6 Feedstock Material alternative. Concentrations would decrease slightly because this alternative would not require the use of the proposed Tritium Separation Facility; however, additional emissions would occur under this alternative from the use of the Tritium Extraction Facility. As with the Preferred alternative, most of the emissions would be attributable to the diesel generators.

Table 4-11 lists air quality impacts to a hypothetical worker in the vicinity of the APT facilities. For all the regulated pollutants emitted, exposures to this nearby worker would be below the permissible exposure levels defined in 29 CFR Part 1910.100.

For the alternate site, Table 4-10 lists the maximum air concentrations at the SRS boundary in the last column and all the resulting emissions would be well below the SCDHEC limits. As the results indicate, all emissions are less than 1 percent of the applicable standards. Most of the nonradiological emissions at the alternate site also are attributable to the three diesel generators. As with the construction activities, concentrations from routine emissions to the hypothetical SRS worker located 640 meters

Table 4-9. Nonradiological air emissions (tons per year) for APT routine operations.<sup>a</sup>

Air emissions	Diesel units	APT	PSD Significant Net Emissions Increase
Sulfur oxides	0.16	N/A <sup>b</sup>	100
Total suspended particulates	0.24	0.30	25
Particulate matter (<10 μm)	0.16	0.15	15
Carbon monoxide	2.5	0.76	100
Ozone (as total VOC)	0.33	0.023	40
Oxides of nitrogen	9.8	1.2	40
Lead	0.0002	N/A	0.6
Beryllium	3.6×10 <sup>-5</sup>	N/A	0.0004
Mercury	4.4×10 <sup>-5</sup>	N/A	0.1
Ethyl alcohol	N/A	0.02	NA

a. Source: Hunter 1997.

b. N/A = No emissions of the regulated pollutant.

**Table 4-10.** Estimated maximum concentrations of regulated nonradiological air emissions at SRS boundary from APT operations at the preferred APT site (micrograms per cubic meter).

Air emissions	Averaging time	Results for Preferred alternative	Percentage difference of results for alternatives						
			Once-through cooling using river water	Cooling water system		Accelerator technology	Feedstock Material	Radio-frequency source	Site location
				Cooling towers with groundwater makeup	K-Reactor cooling tower with river water makeup				
					Room temperature	Lithium-6 aluminum alloy	Inductive output tube	Alternate site	
Oxides of sulfur	3-hour	0.13	NC <sup>a</sup>	NC	NC	NC	NC	NC	+7.7%
	24-hour	0.016	NC	NC	NC	NC	NC	NC	+13%
	Annual	0.00014	NC	NC	NC	NC	NC	NC	+14%
Total suspended particulates	Annual	0.00057	NC	NC	NC	NC	-32%	NC	+40%
Particulate matter (≤10 microns)	24-hour	0.016	NC	NC	NC	NC	-20%	NC	+19%
	Annual	0.0003	NC	NC	NC	NC	-30%	NC	+40%
Carbon monoxide	1-hour	6.1	NC	NC	NC	NC	NC	NC	+15%
	8-hour	0.76	NC	NC	NC	NC	-5%	NC	+16%
Ozone (as total VOC) <sup>b</sup>	1-hour	0.75	NC	NC	NC	NC	NC	NC	+15%
Oxides of nitrogen	Annual	0.0091	NC	NC	NC	NC	NC	NC	+21%
Lead	Max. Quarter	$2.4 \times 10^{-7}$	NC	NC	NC	NC	NC	NC	+8.3%
Beryllium	24-hour	$3.5 \times 10^{-6}$	NC	NC	NC	NC	NC	NC	+17%
Mercury	24-hour	$4.4 \times 10^{-6}$	NC	NC	NC	NC	NC	NC	+16%

a. NC = Difference in results between this alternative and the Preferred alternative is less than 5 percent.

b. Ambient concentrations of volatile organic compounds are a highly conservative bounding estimate for ozone. Values in the table are for information only and should not be used for explicit assessments of compliance with the ozone standard.

**Table 4-11. Estimated maximum concentrations at hypothetical worker location (640 meters) from APT operations of nonradiological air pollutants regulated by OSHA at the preferred APT site (milligrams per cubic meter).<sup>a</sup>**

Air emissions	Averaging time <sup>b</sup>	OSHA standard <sup>b</sup>	Results for Preferred alternative	Percentage difference of results for alternatives						
				Cooling water system		Accelerator technology	Feedstock Material	Radio-frequency power	Site location	
				Once-through cooling using river water	Cooling towers with groundwater makeup					K-Reactor cooling tower with river water makeup
Oxides of sulfur	8-hour TWA	13	0.0037	NC <sup>c</sup>	NC	NC	NC	NC	NC	NC
Total particulates	8-hour TWA	15	0.0058	NC	NC	NC	NC	-5%	NC	NC
Particulate matter ( $\leq 10$ microns)	8-hour TWA	5	0.0037	NC	NC	NC	NC	NC	NC	NC
Carbon monoxide	8-hour TWA	55	0.060	NC	NC	NC	NC	NC	NC	NC
Oxides of nitrogen	Ceiling	9	1.8	NC	NC	NC	NC	NC	NC	NC
Lead	8-hour TWA	0.5	$4.4 \times 10^{-6}$	NC	NC	NC	NC	NC	NC	NC
Beryllium	8-hour TWA	0.002	$8.4 \times 10^{-7}$	NC	NC	NC	NC	NC	NC	NC
	Ceiling	0.005	$6.7 \times 10^{-6}$			NC	NC	NC	NC	NC
Mercury	8-hour TWA	0.1	$8.4 \times 10^{-6}$	NC	NC	NC	NC	NC	NC	NC
Ethyl Alcohol	8-hour TWA	1900	$6.0 \times 10^{-5}$	NC	NC	NC	NC	-25%	NC	NC

a. Source: Hunter (1997).

b. Air pollutants regulated by OSHA under 29 CFR Part 1910. Averaging values listed are 8-hour time weighted averages (TWA) except those oxides of nitrogen that are not-to-be exceeded Ceiling Values. Beryllium has both an 8-hour TWA and a ceiling limit. Source: 29 CFR Part 1910.100.

c. NC = Difference in results between this alternative and the Preferred alternative is less than 5 percent.

d. Results at the alternate site do not change from the preferred site since the receptor remains at the same location relative to the APT facility.



from the APT facilities at the alternate site would be essentially the same as those for the preferred site listed in Table 4-11.

Although the various alternatives for supplying cooling water to the APT facilities would not contribute to the release of regulated pollutants, those alternatives utilizing cooling towers would have some impacts due to drift, fogging, and solids deposition in the vicinity of the towers. DOE has studied the environmental effects of atmospheric releases from natural draft and mechanical-draft cooling towers at the SRS (DOE 1987a). That study was for the purpose of providing cooling to the SRS reactors. The heat to be dissipated to the atmosphere from the APT cooling towers would be approximately one-fifth of that analyzed for the reactors. Because the amount of drift, fogging, and solids deposition is directly related to heat load, the environmental effects from the APT would be significantly less than those for reactor cooling.

The recirculating cooling towers considered for use with the reactors consisted of a hot end natural-draft tower in series with mechanical-draft towers. The heat load on the mechanical-draft portion of the system was approximately the same as that projected for the APT towers. The tower system intended to cool K-Reactor would have a calculated maximum annual frequency of ground-level visibility reduced to less than 0.6 mile in any direction (fogging) of about 2 hours a year. The calculated maximum ice accumulation on horizontal surfaces (e.g., roads) would be no more than 0.3 inch, occurring within 0.2 miles of the towers, and no more than 0.04 inch beyond 0.5 miles from the towers. The maximum occurrence of visible plumes aloft would be about 180 hours per year at 1.2 miles from the tower.

The preferred APT cooling system would operate at three cycles of concentration (i.e., three times as much solids in the blowdown as in the makeup), the same as the towers analyzed in 1987. The maximum total solids deposition would be about 60 pounds per acre per year, occurring within 0.3 mile of the towers, decreasing to 5.7 pounds per acre per year at 1.2 miles

from the towers. These deposition concentrations assume the Savannah River would be the source of makeup water; if DOE chose the option of groundwater as the source of cooling tower makeup water, the deposition concentrations would be 3 orders of magnitude less (the difference in source water dissolved solids concentration). The impacts from the APT mechanical-draft cooling towers would be significantly less than those projected for reactor operation because of the decreased heat load (i.e., reactor impacts are due to both the hot end natural-draft tower and the mechanical-draft towers). APT impacts would be comparable to the mechanical-draft tower alone.

Section 4.2.2.1 discusses impacts on vegetation or wildlife from cooling tower operation. Non-radiological impacts from cooling towers for the alternate site would be the same as those described for the preferred site.

The natural-draft tower analyzed for use with the K-Reactor is the same tower DOE is considering for the K-Area Cooling Tower alternative for the APT. The tower would have a maximum annual frequency of ground-level visibility reduced to less than 0.6 mile in any direction (fogging) calculated to be less than 2 hours per year; the calculated maximum ice accumulation on horizontal surfaces (e.g., roads) would be no more than 0.4 inch. The maximum occurrence of visible plumes aloft would be 180 hours per year in the immediate vicinity (0.2 mile) of the cooling tower and 50 hours per year at 1.2 miles from the tower.

#### 4.1.3.4 Radiological Air Emissions

After determining the routine emission rates, DOE used the computer codes MAXIGASP and POPGASP to estimate radiological doses to the maximally exposed individual (MEI) and to the population surrounding the SRS. MAXIGASP and POPGASP are both site-specific computer programs, which means that meteorological parameters (e.g., wind speed and direction) and population distribution parameters (e.g., number of people surrounding the SRS, location of people in sectors around the

site) are integrated into the programs. Meteorology gathered at the SRS for the period from 1987 through 1991 (the most recent validated data set available) was used for the radiological dispersion modeling. For conservatism, releases were assumed to be ground level. The 1990 population census database was used to represent the population that lives within a 50-mile radius of the center of the SRS. For the APT airborne releases, the MEI would be at the SRS boundary in the north sector.

Although a large number of radionuclides would be emitted as a result of normal operations, only a few would account for essentially all of the potential dose. For the Preferred alternative, radiological emissions are expected from the accelerator building, the target blanket building, and the Tritium Separation Facility. The APT facility is assumed to operate 24 hours a day, 365 days a year. Sources of radioactive emissions include activated air in the accelerator tunnel which includes radionuclides such as Argon-41 and Carbon-11. Operation of the Tritium Separation Facility accounts for approximately 85 percent of the Tritium emitted by the APT facilities. A majority of the radionuclides emitted come from the target/blanket building, including some Tritium and Carbon-11 and all of the Beryllium-7 and Iodine-125 emissions. Emissions also can result from fugitive sources such as minor leaks in system piping and other process leaks, as well as maintenance activities which require systems to be opened. Annual emissions (curies) for the radionuclides that are the major contributors to dose are presented in Table 4-12. Tritium (assumed to be Tritium oxide) emissions would produce the highest impact to the MEI with 99.35 percent of the estimated dose, followed by Argon-41 with 0.43 percent of the dose (Simpkins 1997d).

Table 4-13 presents the calculated maximum radiological doses from routine operations. According to these results, the calculated maximum committed effective dose equivalent to a hypothetical individual at the SRS boundary is 0.036 millirem for each year of operation, which

**Table 4-12.** Annual radionuclide emissions from routine operations of the APT facility (curies).<sup>a</sup>

Radionuclide	Annual emissions
Tritium	10,000
Carbon-11	250
Argon-41	30
Beryllium-7	.02
Iodine-125	.0027

a. Source: Shedrow 1997a.

is well below the annual dose limit of 10 millirem from SRS atmospheric releases. None of the cooling water configurations contribute to the annual dose; likewise, using room temperature operation or using inductive output tubes does not affect the dose results. The use of Lithium-6 feedstock material would necessitate operation of the Tritium Extraction Facility which would have additional radiological emissions. The estimated dose to the MEI for the Lithium-6 Feedstock Material alternative is 0.014 millirem, of which 57 percent is attributable to the Tritium Extraction Facility.

Tritium is estimated to be the major contributor to the offsite population dose with a calculated dose of 1.2 person-rem per year for the preferred configuration. The population dose associated with the use of a Lithium-6 feedstock material is 0.58 person-rem with 0.39 person-rem or 67 percent attributable to the Tritium Extraction Facility in H-Area.

Table 4-13 also lists the onsite worker dose (hypothetical worker 640 meters downwind) resulting from radiological releases. The estimated maximum committed effective dose equivalent to the worker from annual Tritium releases is 1.4 millirem for each year of operation. As with the MEI dose, using the Lithium-6 feedstock material affects the radiological impacts. The dose for the Lithium-6 Feedstock Material alternative decreases the dose from the Preferred alternative by 77 percent. Doses would decrease under this alternative because

**Table 4-13. Annual radiological doses from routine radiological air emissions from the APT.<sup>a</sup>**

Receptor	Doses for Preferred alternative	Percentage differences of doses for alternatives						
		Cooling water system			Accelerator technology	Feedstock Material	Radio-frequency source	Site location
		Once-through cooling using with river water	Cooling towers with groundwater makeup	K-Reactor cooling tower with river water makeup	Room temperature	Lithium-6 aluminum alloy <sup>c</sup>	Inductive output tube	Alternate site
MEI dose (millirem)	0.036	NC <sup>b</sup>	NC	NC	NC	-61%	NC	+53%
Population dose (person-rem)	1.2	NC	NC	NC	NC	-52%	NC	+8%
Worker dose (millirem)	1.4	NC	NC	NC	NC	-77%	NC	NC

a. Source: Simpkins (1997d,e,f).  
 b. NC = Difference in doses between this alternative and the Preferred alternative is less than 5 percent.  
 c. Includes radiological emissions from operation of the Tritium Extraction Facility.

the Tritium Extraction Facility is likely to emit less Tritium than the Tritium Separation Facility (5,000 curies per year versus 8,500 curies per year) and is farther from the SRS boundary. In the event the Tritium Separation and Tritium Extraction Facilities are combined at the APT site, administrative controls would limit the curie content of the facilities.

As with the nonradiological impacts, radiological doses from the alternate site are slightly greater due to the site's location in relation to the SRS site boundary. The calculated committed effective dose equivalent to the MEI residing at the SRS boundary is 0.056 millirem for each year of operation, which is well below the annual dose limit of 10 millirem from SRS atmospheric releases (Table 4-13). The offsite population dose from APT operations at the alternate site would be 1.3 person-rem per year.

The onsite worker dose resulting from radiological releases is the same as that reported in Table 4-13 since the worker is located the same distance (640 meters) from the APT for both sites.

None of the alternatives for either the preferred or alternate site would result in concentrations or radiological doses that would exceed the regulatory limits. Section 4.2 describes the potential health effects of these releases on members of the public and workers for the alternate site.

#### 4.1.4 LAND USE AND INFRASTRUCTURE

This section evaluates potential impacts of the construction and operation of the APT on SRS land use and infrastructure (e.g., roads, power lines, and piping).

**Construction.** DOE would clear land to provide the area for the APT facilities (approximately 250 acres) in addition to land for concrete batch plants and corridors that would connect the site to SRS utilities, provide roads and railroads, provide access to liquid effluent discharge outfalls, and connect to other support

facilities (e.g., liquid waste treatment facilities). Both APT sites are designated as forest timber units under the SRS land use system, but would be redesignated for APT use if either became the APT site.

Construction of the APT would result in converting about 250 acres (additional land would be required for the modular design variation) of forested land into an industrialized area. New roads, bridge upgrades, and rail lines would be required. Negligible operational impacts on existing site infrastructure are expected.

The amount of roads and railroads necessary for APT operations would depend primarily on the site selected. DOE would build about 8 miles of new road, upgrade bridges, and build 3.8 miles of railroad for the preferred site (Shedrow 1997b); these lengths would be necessary to connect the APT site to existing SRS roads and rail lines and to provide additional access to the APT site. The alternate site is closer to an existing road and, therefore, would require less roadway construction. However, the alternate site is farther from a rail line and would require a longer rail connection than the preferred site. In addition, the rail line to the alternate site would require the construction of a support trestle across Tims Branch or Upper Three Runs, which could affect wetlands. Figure 3-10 shows the SRS network of primary roads and the SRS railroad system in relation to the preferred and alternate sites. Prior to selecting rail spurs, DOE would evaluate corridors for the presence of threatened and endangered species, archaeological sites, or other sensitive resources such as wetlands.

Pipeline construction would be required to carry river water to the preferred site (approximately 18,000 feet); for the alternate site about 24,600 feet would be required. The groundwater makeup alternative would require additional land disturbance activities to install a well system.

The preferred site would require construction of approximately 23,000 feet of discharge line to

reach the proposed APT outfall. The alternate site would require construction of approximately 43,000 feet of discharge line (WSRC 1996b).

The preferred and alternate sites are relatively close to existing transmission lines, so construction of connector transmission lines would have minimal environmental impacts. The impact of providing additional electrical capacity to support the APT facilities is discussed in Section 4.4.

DOE would pump sanitary wastewater from the APT to the Central Sanitary Wastewater Treatment Facility. Both the preferred and alternate APT sites are within about 3 miles of a main collection system line that flows to this facility. However, the construction of a sewer collection line from the preferred site would have fewer environmental impacts because DOE would have to build the line connecting the alternate site to the collection system in and across more sensitive areas (wetlands and streams).

**Operations.** DOE analyzed the amount of electric power necessary to operate the APT components and estimated requirements by alternative, as listed in Table 4-14 (Shedrow 1997c). The table indicates that power use is more for the Room Temperature Operation alternative and less for the Inductive Output Tube alternative; the other alternatives would use such similar equipment that their power requirements would be virtually the same. In addition to the electric power listed in Table 4-14, DOE would maintain diesel generators at the site to provide backup power when needed, and would operate the generators on a routine basis to ensure their operability; this would consume 20,000 gallons of diesel fuel per year, regardless of alternative.

DOE has estimated the volume of water necessary to operate the APT facilities. To determine total use, DOE considered both potable and nonpotable water. DOE based its estimates of potable water use on the projected number of workers who would work in the APT facilities

on an annual basis, because the largest use of potable water would be for human consumption. Therefore, for most alternatives, potable water use would not vary much; the Lithium-6 Feedstock Material alternative would use less water because it would not include a Tritium Separation Facility, as discussed in Chapter 2. DOE would provide potable water by connecting to existing SRS water lines, as shown in Figure 3-13.

The major use of nonpotable water for APT facilities would be as cooling water. Therefore, the volume of nonpotable water would vary somewhat depending primarily on the cooling water alternative that DOE implemented and on the heat generated by the other alternatives. Table 4-14 lists nonpotable water requirements by alternative. Understandably, the requirements would be less for alternatives that involved cooling towers and for alternatives that generated less heat in the facility. As discussed in Chapter 2, DOE would supply nonpotable water through either the existing River Water System or new groundwater wells. The Department could supply nonpotable water for uses other than cooling water (e.g., fire protection) by connecting to existing SRS process water lines. The cooling water impacts are discussed in Section 4.1.2.

#### 4.1.5 WASTE MANAGEMENT

DOE has determined that construction and operation of the APT facilities would result in generation of several types of radioactive and nonradioactive waste.

The generation of construction waste could require the construction of a state-permitted construction debris landfill on the SRS. Sanitary solid waste would be disposed of in the Three Rivers Regional Landfill. Operational waste would be managed and treated according to waste type using both SRS and offsite facilities. Potential impacts to other facilities are expected to be negligible due to the relatively low volume of waste generated. The potential impacts of transporting the radioactive waste is discussed in Section 4.2.1.2.

**Table 4-14. Electric power and water use for APT operations.**

Utility	Results for Preferred alternative	Percentage difference of results for alternatives						
		Cooling water system			Accelerator technology	Feedstock Material	Radio-frequency power	Site location
		Once-through cooling using river water	Cooling towers with groundwater makeup	K-Reactor cooling tower with river water makeup	Room temperature	Lithium-6 aluminum alloy	Inductive output tube	Alternate site
Annual electricity use	3.1 terawatt-hours per year	NC <sup>a</sup>	NC	NC	+22%	NC	-9%	NC
Average electricity use	350 megawatts	NC	NC	NC	+22%	NC	-9%	NC
Peak electricity use	490 megawatts	NC	NC	NC	+22%	NC	-9%	NC
Fuel use (diesel generator)	20,000 gallons per year	NC	NC	NC	NC	NC	NC	NC
Annual potable water use	5.6 million gallons	NC	NC	NC	NC	-7%	NC	NC
Peak potable water use	800 gallons per minute	NC	NC	NC	NC	-5%	NC	NC
Average potable water usage	20,000 gallons per day	NC	NC	NC	NC	-5%	NC	NC
Annual nonpotable water use	2.62 billion gallons per year	+2,000% <sup>b</sup>	NC	NC	+13%	NC	-8%	NC
Peak nonpotable water use	6,000 gallons per minute	+2,000% <sup>c</sup>	NC	NC	+13%	NC	-8%	NC
Average nonpotable water use	5,000 gallons per minute	+2,000% <sup>d</sup>	NC	NC	+13%	NC	-8%	NC

a. NC = Difference in impacts between this alternative and the Preferred alternative is less than 5 percent.  
 b. 55 billion gallons per year.  
 c. 130,000 gallons per minute.  
 d. 110,000 gallons per minute.

**Construction.** The construction phase would generate nonhazardous, nonradioactive wastes, including sanitary solid wastes, construction debris (mixed rubble, metals, plastics), and sanitary wastewater. Table 4-15 lists estimated maximum annual quantities of waste for construction of the Preferred alternative and compares it with the other alternatives.

DOE could dispose of APT sanitary solid waste at the Three Rivers Regional Landfill, an onsite regional nonhazardous landfill. The maximum annual volume of sanitary solid waste attributable to APT construction under any alternative would be less than 1 day's contribution to the average daily disposal rate of 900 tons at the Three Rivers Regional Landfill. The landfill will be operational during the projected APT construction and operation periods (DOE 1995a).

DOE could construct a State-permitted construction and debris landfill on the SRS exclusively for APT construction wastes to dispose of mixed rubble and other nonrecyclable construction debris. In addition, DOE could use an existing SRS landfill or transfer the construction waste to an offsite commercial landfill. DOE estimates a total of 170,000 cubic meters of construction debris for disposal during APT construction.

During construction, sanitary wastewater would be managed by an offsite vendor using portable restroom facilities until DOE could build permanent restroom facilities at the APT site. Because the vendor would be responsible for disposing of this sanitary wastewater, it would not affect SRS wastewater treatment facilities. After the connection of the APT facilities to the Central Sanitary Wastewater Treatment Facility, the maximum annual volume attributable to APT construction under any alternative during construction would represent approximately 1.5 days at that facility's daily operating capacity of about 1 million gallons.

**Operations.** APT operations would generate a number of radioactive and nonradioactive waste streams. In addition, some of the APT radioactive waste would be mixed (Resource Conser-

vation and Recovery Act hazardous and radioactive) waste. Because APT does not involve fission and DOE would not use materials with high atomic numbers in the accelerator, the accelerator would not generate high-level radioactive or transuranic wastes. However, some of the radioactive waste from the target/blanket cavity would be high concentration radioactive waste (Shedrow 1997a).

RCRA is the Federal statute governing the management of hazardous waste from generation to disposal. Hazardous waste includes such materials as waste solvents, toxic metals, and industrial process waste products.

The classification of radioactive wastes is based on the concentration of short- and long-lived radionuclides. High concentration wastes contain long-lived radionuclides. Classes A and B include radioactive wastes with concentrations of short-lived and perhaps some long-lived radionuclides. Because high concentration radioactive wastes contain long-lived radionuclides they require special disposal considerations.

The wastes would be generated as part of the production process, decontamination process, analytical activities, and operation of supporting facilities; they would also be generated incidentally as a result of failed equipment, routine maintenance, and off-normal events. Table 4-16 lists the waste types generated by activity and examples of items included in each waste type.

Table 4-15 lists estimated annual waste quantities from APT operations for the Preferred alternative and compares them to the other alternatives. The waste estimates are based on engineering assessments, waste forecasts, and waste management plans.

The APT facilities would be able to pretreat, treat, accumulate, handle, and package the wastes it generated to prepare them for shipment to a waste treatment, storage, or disposal facility. DOE would manage APT wastes for

**Table 4-15. Waste generation and impacts comparison for preferred configuration and alternatives.<sup>a</sup>**

Environmental factor (waste type)	Annual waste quantities for Preferred alternative	Percentage differences of waste quantities for alternatives						
		Cooling water system		Accelerator technology		Feedstock Material	Radio-frequency power	Site location
		Once-through cooling using river water	Cooling towers with groundwater makeup	K-Reactor cooling tower with river water makeup	Room temperature	Lithium-6 aluminum alloy	Inductive output tube	Alternate site
Construction wastes <sup>a</sup> maximum based on construction schedule								
Sanitary solid	560 cubic meters	NC <sup>b</sup>	NC	NC	-9%	NC	NC	NC
Construction debris	30,000 cubic meters	NC	NC	NC	NC	NC	NC	NC
Sanitary wastewater	1.5 million gallons	NC	NC	NC	-9%	NC	NC	NC
Operations waste								
Sanitary solid	1,800 metric tons	NC	NC	NC	NC	NC	NC	NC
Industrial	3,800 metric tons	NC	NC	NC	NC	NC	NC	NC
RCRA hazardous	1.0 cubic meter	NC	NC	NC	NC	NC	NC	NC
Radioactive wastewater	140,000 gallons	NC	NC	NC	NC	NC	NC	NC
Low-level waste <sup>c</sup>	1,400 cubic meters	NC	NC	NC	NC	+17%	NC	NC
High concentration low-level waste	2.5 cubic meters	NC	NC	NC	NC	NC	NC	NC
Mixed waste <sup>c</sup>	1.0 cubic meter	NC	NC	NC	NC	-11%	NC	NC
High concentration mixed waste	12 cubic meters	NC	NC	NC	NC	+25%	NC	NC
Sanitary wastewater	3.3 million gallons	NC	NC	NC	NC	-5%	NC	NC
Nonradioactive process wastewater	920 million gallons	+2,000% <sup>d</sup>	NC	NC	+37%	NC	-5%	NC

a. Sources: Shedrow (1997a,b).

b. NC = Difference in impacts between this alternative and the Preferred alternative is less than 5 percent.

c. Excluding High concentration waste.

d. 19 billion gallons.



**Table 4-16. Waste types, generating activities, and examples.<sup>a</sup>**

Waste type	Generating activity	Examples of waste stream items
Sanitary solid	Offices, change rooms	Paper
Industrial	Production, maintenance, housekeeping	Failed nonrecyclable equipment, expired nonhazardous chemicals
RCRA hazardous	Production, maintenance, housekeeping	Batteries
Radioactive wastewater	Cooling water systems, cooling pool, decontamination, radiological control analytical activities, pollution control equipment	Radioactive light water, aqueous solutions
Low-level radioactive	Maintenance, radiological surveys, production	Personal protective equipment, absorbent wipes, failed equipment
High concentration radioactive	Maintenance	Target/blanket cavity vessel window modules, tungsten neutron source modules
Mixed	Production, maintenance	Failed process equipment
High concentration mixed	Maintenance	Lead modules
Sanitary wastewater	Bathrooms	Wastewater
Nonradioactive process wastewater	Tertiary cooling system, radiofrequency tube cooling, rainwater and groundwater infiltration, waste treatment secondary wastes, groundwater monitoring	Cooling water with traces of salts, corrosion inhibitor, slimicide, dispersant; rainwater, groundwater, wastewaters

<sup>a</sup>. Source: Shedrow (1997a).

treatment and disposal according to waste type, using SRS and offsite waste treatment, storage, and disposal facilities. Table 4-17 lists the waste types and quantities destined for treatment, storage, and disposal facilities and the subsequent impact to the facility, divided by preferred configuration and alternative.

The SRS Consolidated Incineration Facility (CIF) would be in operation for the first 20 years of APT operations (DOE 1995b), and DOE would add APT incinerable waste (low-level radioactive and mixed wastes) to incoming CIF waste volumes (Shedrow 1997c). Table 4-17 lists impacts to the CIF. When the CIF was no longer operational, DOE would continue to manage APT wastes as directed in applicable Federal, state, and DOE requirements. At present, offsite vendor facilities are available for the volume reduction of many low-level radioactive waste streams (Shedrow 1997a), and DOE expects such facilities to be available when the CIF is no longer operational.

DOE may send low-level radioactive waste suitable for compaction to an on- or offsite vendor-

operated compactor. At present, the SRS ships such waste to an offsite vendor for compaction (Shedrow 1997a). DOE could place an existing onsite compactor in service in the future; Table 4-17 lists potential impacts to that compactor.

APT low-level waste treated at offsite vendor facilities would return to the SRS for disposal in the E-Area vaults. These vaults would also dispose of APT low-level waste not treated off the site. Two types of vaults -- Low-Activity Waste and Intermediate-Level Tritium -- would be available for the disposal of APT wastes. Table 4-17 lists the impacts to each.

Consistent with current practice, DOE could dispose of APT hazardous waste at a DOE-approved commercial facility (Shedrow 1997a). The estimated annual volume of hazardous waste that DOE would treat and dispose of off the Site would be low (1.0 cubic meter), and its impact on the offsite facility would be negligible.

Table 4-17. Impacts on treatment, storage, and disposal facilities for operation of preferred configuration and alternatives.<sup>a,b</sup>

Waste facility <sup>c</sup>	Waste quantity (Preferred alternative)	Waste type <sup>d</sup>	Operating capacity	Impact for preferred configuration	Impact for room temperature	Impact for Lithium-6 Feedstock Material
CIF	500 m <sup>3</sup> /yr	Incinerable LLRW, incinerable MW	9,500 m <sup>3</sup> /yr <sup>e,f</sup>	5 percent of capacity	N/Cg	N/C
Onsite compactor	75 m <sup>3</sup> /yr	LLRW	1,600 m <sup>3</sup> /yr	5 percent of capacity	N/C	+80%
E-Area LAW vault	33,000 m <sup>3</sup> total <sup>h</sup>	LLRW, compacted LLRW, LLRW ash	31,000 m <sup>3</sup> / vault <sup>e</sup>	1.1 vault	N/C	+8%
E-Area ILTV	2,100 m <sup>3</sup> total <sup>h</sup>	LLRW with Tritium	5,300 m <sup>3</sup> /vault <sup>e</sup>	0.4 vault	N/C	+6%
Storage building	600 m <sup>3</sup> total <sup>h</sup>	MW, MW ash, high concentration	620 m <sup>3</sup> /bldg. <sup>e</sup>	1 building	N/C	+20%
Three Rivers Landfill	5,600 metric tons per year	Sanitary solid, in- dustrial solid	900 metric tons per day <sup>i</sup>	6.2 days per year	N/C	N/C
Central Sanitary WTF	3.3 million gallons	Sanitary wastewater	1 million gallons per day	3.3 days	N/C	N/C

a. Source: Shedrow (1997a).

b. Impacts for other alternatives would not vary from the Preferred alternative impacts.

c. Waste facilities: CIF = Consolidated Incineration Facility; LAW = Low Activity Waste; ILTV = Intermediate Level Tritium Vaults; WTF = Wastewater Treatment Facility.

d. Waste types: LLRW = low-level radioactive wastes; MW = mixed waste.

e. Source: DOE (1995b).

f. All waste considered as solid feed.

g. N/C = difference within 5 percent.

h. 40-year total.

i. Source: DOE (1995a).

DOE would treat mixed waste that could not be incinerated at the Consolidated Incineration Facility at the APT and then store the treated waste at SRS mixed waste storage pads or buildings before disposing of it off the Site. In addition, DOE would store stabilized APT mixed waste ash from the CIF before disposing of it. Similar to APT-generated hazardous waste, the annual volume of mixed waste that would require onsite storage and offsite treatment and disposal would be relatively low (1.0 cubic meter). Table 4-17 lists the impacts of storing APT mixed waste and high concentration waste (mixed and nonmixed) in SRS mixed-waste storage facilities. Other DOE sites could treat and dispose of mixed waste, and the Department has approved commercial vendors for treating and disposing of mixed wastes (Shedrow 1997a). DOE expects impacts on the treatment capabilities of other facilities to be negligible due to the low volume of waste.

The APT would generate several hundred cubic meters of high concentration radioactive waste (Greater-Than-Class-C Waste) over its 40-year operational life; most would be mixed waste. DOE is investigating material substitutions that would minimize or eliminate this waste stream; however, if the waste was generated, the Department has several potential disposal options, each requiring more investigation. The most likely options are the proposed Yucca Mountain Repository in Nevada, the Hanford Site, the Nevada Test Site, and the SRS. The SRS inventory of such waste (excluding APT) will be 1,500 cubic meters by 2035 (England 1997). The operation of the APT would increase the inventory of this waste stream by one-third.

DOE would selectively treat radioactive and nonradioactive process wastewater in the APT waste treatment systems described in Appendix A, and would discharge treated wastewater

to a State-permitted outfall. The estimated annual discharge volumes would be 920 million gallons for the preferred configuration (Shedrow 1997a). Sections 4.1.2 and 4.2.2 discuss the impacts of these discharges.

APT sanitary wastes and wastewaters would have little impact on the SRS treatment and disposal facilities. The sanitary wastes would include nonhazardous industrial solid waste such as failed nonradioactive nonrecyclable equipment, and nonhazardous chemicals and biocides. Table 4-17 lists estimated waste volumes and expected impacts on the Three Rivers Regional Landfill and the SRS Central Sanitary Wastewater Treatment Facility.

#### 4.1.6 VISUAL RESOURCES AND NOISE

##### 4.1.6.1 Visual Resources

Impacts on visual resources would be influenced by the relative size (particularly height) of the APT facilities, dissimilarity to surroundings (shape and color), and number and frequency of viewers.

The construction and operation of the APT and associated support structures would not be visible to ground-level observers from the SRS boundaries at either the preferred or alternate site. Views of the accelerator and its associated buildings by visitors or employees using the SRS road network would be limited by the forest vegetation and rolling terrain surrounding the sites. Most of the proposed buildings would not exceed the height of the surrounding forest vegetation. The tallest structures, two air emission stacks and a water storage tank, would not be more than 200 feet high and like the K-Area Cooling Tower (which is 490 feet high) would not be generally visible to ground-level observers from the SRS boundaries. Site visitors and employees observing the APT facility and support structures would find the site similar to other developed industrial areas on the SRS. Visible plumes aloft would have a limited impact on visual resources. Section 4.1.3.2 discusses the potential impacts to air quality and to

visual resources of mechanical-draft and natural-draft cooling tower emissions.

##### 4.1.6.2 Noise

Noise can produce adverse effects on the physical, mental, and emotional health of individuals. It can also disturb wildlife, displacing animals and interfering with normal patterns of resting, foraging, feeding, roosting, nesting, and reproducing. This section examines the impacts of noise from construction and operation of the accelerator and its related facilities on workers and nearby offsite residents, and provides data for analysis of noise impacts on wildlife in Section 4.2.2.

*Construction.* All alternatives would produce noise from the construction of the APT facilities at the preferred or alternate site, construction of a rail spur to the APT facilities, operation of concrete batch plants and other support facilities, and traffic from construction workers and delivery trucks. For alternatives that would use river water cooling, the construction of supply and discharge pipelines would generate noise. This noise, originating from several locations, would occur with varying intensity over the 10-year construction period.

*Noise Near the APT Site.* Heavy noise from the construction of facilities, operation of batch plants, and construction of pipelines and railways would consist of noise from earth-moving equipment, trucks, air compressors, jackhammers, and other sources listed in Table 4-18.

Construction noise at the APT site could be higher than the limits imposed by OSHA. However, DOE would ensure compliance with OSHA 8-hour noise exposure guidelines through the use of administrative controls, engineering, and protective equipment. Noise to offsite receptors would not present a nuisance. Operational noise would be less than construction phase noise and would have negligible impacts to workers and the public.

**Table 4-18.** Peak and attenuated noise levels (in dBA) expected from operation of construction equipment.<sup>a</sup>

Source	Noise level (peak)	Distance from source			
		50 feet	100 feet	200 feet	400 feet
Heavy trucks	95	84-89	78-83	72-77	66-71
Dump trucks	108	88	82	76	70
Concrete mixer	105	85	79	73	67
Jackhammer	108	88	82	76	70
Scraper	93	80-89	74-82	68-77	60-71
Bulldozer	107	87-102	81-96	75-90	69-84
Generator	96	76	70	64	58
Crane	104	75-88	69-82	63-76	55-70
Loader	104	73-86	67-80	61-74	55-68
Grader	108	88-91	82-85	76-79	70-73
Dragline	105	85	79	73	67
Pile driver	105	95	89	83	77
Forklift	100	95	89	83	77

a. Source: Golden et al. (1980).

The table indicates that construction noises can be quite loud close to the sources, but rapidly decrease with distance. During peak construction times, a number of noise sources would be distributed across the construction site. For example, DOE calculated the noise of 10 dump trucks and 10 pile drivers at the same point; using the data from Table 4-18, the noise level would be 83 dB(A) at 400 feet. DOE uses this value as the sound pressure level for determining ecological impacts at the edge of the construction site (see Section 4.2.2). Section 3.3.7 provides a scale for comparing predicted noise with common noise levels.

**Construction Noise at the APT Site.** Workers at the construction site(s) could encounter noises higher than the limits imposed by the Occupational Safety and Health Administration (OSHA). However, DOE would ensure that construction contractors complied with OSHA noise regulations (29 CFR Part 1926.52), which limit 8-hour noise exposures to 90 dB(A). Administrative controls, engineering controls, or personal protective equipment would be used as required to comply with OSHA limits.

**Construction Transportation Noise.** Noise from the transportation of workers and materials to and

from the construction site could increase along the most frequently used routes. The most probable routes are State Route 125 from Augusta, Georgia, State Route 19 from Aiken, South Carolina, and U.S. Route 1 between Augusta and Aiken connecting State Routes 125 and 19. In 1991 DOE commissioned a quantitative analysis of construction traffic noise for a proposed new reactor at the SRS (Chun and Rabchuk 1991), which concluded that construction traffic noise would not result in a significant incremental noise increase. The APT construction project would involve 66 percent fewer construction workers than the proposed reactor project; however, the assumed baseline traffic volume would be less due to decreases in overall SRS employment since 1991.

**Offsite Noise.** The nearest SRS boundary is about 6 miles north of the preferred site and 4 miles north of the alternate site; the nearest population centers (New Ellenton and Talatha, South Carolina) are about 8 miles north of either site. The land between the two sites and the population centers is heavily forested, providing maximum noise reduction.

Based on the following information, DOE believes that construction noise at offsite recep-

tors would be sufficiently low in comparison to background noise that it would not present a nuisance to most receptors.

- A survey of baseline sound pressure levels performed in the summer of 1989 and the winter of 1990 (NUS 1990) indicated that sound pressure levels near population centers ranged from 65 to 67 dB(A) during daytime hours on summer weekdays and extended as low as 56 dB(A) during nighttime hours on winter weekends. The measurement notes from these studies do not report identifiable noises from the SRS, although three SRS industrial facilities were 5, 7.5, and 8 miles away (M-, F-, and H-Areas, respectively).
- Quantitative modeling of potential impacts from construction of the New Production Reactor (Chun and Rabchuk 1991) indicated that construction noise at the SRS boundary 7 miles north of the proposed site was below the threshold of hearing.

**Operations.** For all alternatives, noise would arise from the operation of the APT at the preferred or alternate site, trains on the rail spur to the facility, and traffic from APT personnel. Other noise could occur from cooling towers, cryogenics compressors, river water pumps, and pipelines.

**Noise Near the APT Site.** Table 4-19 lists the most significant noise sources. Figure A-1 shows their physical locations. Even during

peak operating times, these sources would not operate simultaneously.

Based on earlier studies near large SRS facilities (NUS 1990), sound pressure levels could be near 60 dB(A). Therefore, DOE does not believe that noise from APT operations would be much greater than background in the wooded areas adjacent to the facility because sound pressure levels decrease rapidly with distance.

**Operations Noise at the APT Site.** Operational workers at the APT site or a power generation site could be subject to noises that exceeded the limits imposed by the Occupational Health and Safety Administration. DOE would design engineered noise attenuation features into these facilities as appropriate and would incorporate administrative controls and require the use of personal protective equipment to ensure adequate worker protection.

**Operations Transportation Noise.** As with construction transportation, noise from the vehicles of commuting workers could increase along the most frequently used transportation routes. The 1991 study of traffic noise for a new reactor at the SRS (Chun and Rabchuk 1991) concluded that operations traffic would not result in a significant incremental noise increase. For comparison, the APT project would involve 48 percent fewer operational workers.

**Offsite Noise.** Based on the following information, APT operations noise at offsite receptors would be sufficiently low in comparison to

**Table 4-19.** Major noise sources during accelerator operations.

Source	Description	Units	Estimated sound pressure level
Mechanical-draft cooling tower	Three cells, each with 150-horsepower motor	9	110 dB (near the tower)
Air compressors	500 horsepower; 2,000 scfm <sup>a</sup> at 125 pounds per square inch gage	2	85-90 dB(A) (near the compressors)
Pumps	300 horsepower	36	90 dB at 3 feet
Chillers	350 horsepower	54	90 dB at 3 feet
Target pumps	5,000 gallons per minute at 40 pounds per square inch; 250-horsepower motor	5	90 dB at 3 feet
TSF HVAC exhaust fans	48,000 scfm; 75-horsepower motor	4	90 dB at 3 feet
Cryogenics facilities	Compressors, turbines, etc.	3	96 dB outside building

a. scfm = Standard cubic feet per minute.

*Environmental Impacts*

background noise that it would not present a nuisance.

- A survey of baseline sound pressure levels (NUS 1990) indicated that such levels at a remote location on the SRS ranged from 30 to 43 dB(A) in the winter and from 49 to 53 dB(A) in the summer. (The higher summer values indicate that much of the noise was from insects.) Although the remote location was surrounded by four major operating facilities (F-Area at 3.5 miles, H-Area at 2.5 miles, K-Area at 3.5 miles, and L-Area at 3 miles), the sound pressure levels were less than at any of the offsite survey locations. Nevertheless, measurement notes from these studies report some industrial noises from SRS facilities. Given the low sound pressure levels at this location, noise from the APT site probably would not be detectable at population centers 8 miles away.
- Quantitative modeling of potential impacts from construction of the proposed New Production Reactor (Chun and Rabchuk 1991) indicated that construction noise would be about 14 dB(A) at the SRS boundary 7 miles north of the proposed site. The 1990 baseline sound pressure levels near population centers north of the Site ranged from 56 to 67 dB(A). Combining the New Production Reactor sound pressure level to these levels would result in a range from 56 to 67 dB(A) (i.e., the noise would be imperceptible). The noise sources modeled for the New Production Reactor were as loud as those at the APT site and were more numerous (about 100 255-horsepower mechanical-draft cooling towers).

The K-Area Cooling Tower alternative would introduce a new noise source. A study for the New Production Reactor (NUS 1991) predicted offsite sound pressure levels from two natural-draft cooling towers would be less than the threshold of hearing; the proposed site was 7 miles from the SRS boundary. Noise from

pumps on the river would probably not be audible except by occasional boat traffic under certain weather conditions.

*Noise Impact Summary.* Table 4-20 summarizes noise impacts by alternative.

## 4.2 Impacts on Human and Biological Environment

### 4.2.1 HUMAN HEALTH

Actions at the SRS affect two groups of people: site workers and the public. In its consideration of impacts, DOE evaluated potential actions in which the alternatives could affect each group of people, and analyzed actions that are reasonably foreseeable for three conditions:

- Construction
- Normal operations (nonaccident conditions)
- Accident conditions

DOE expects an incremental increase in occupational injuries based on historic SRS information for injuries requiring first aid, injuries requiring medical attention, and injuries resulting in lost work time during the construction phase. DOE also expects a slight increase in the potential for traffic fatalities.

From normal operations, DOE expects the increase of latent cancer fatalities attributable to the APT related radiological releases to the public to be very small. Similarly, all concentrations for noncarcinogenic materials are well below all established limits and consequently no health impacts are expected. Beryllium is the only carcinogen of concern. The incremental risk of cancer from this material is also very small. Impacts would be slightly higher at the alternate site because it is closer to the SRS boundary. Potential impacts to workers would be slightly higher although in all cases below threshold limits.

**Table 4-20. Noise impacts by alternative.**

Alternative	Impact
Preferred configuration	Construction: Significant near-field noise with potential to disturb wildlife near the project boundary. Offsite impacts are not expected.  Operations: Significant near-field noise with potential to disturb wildlife near the project boundary. Offsite impacts are not expected.
Cooling water alternatives	
Once-Through Cooling Using River Water	Same as Preferred alternative except there would be no mechanical-draft cooling tower noise, which constitutes a large fraction of operational noise
K-Area Cooling Tower with River Water Makeup	Same as Preferred alternative except K-Area cooling tower would provide additional noise sources remote from the project site and the operations noise of the APT would be less.
Mechanical-Draft Cooling Tower with Groundwater Makeup	Same as the Preferred alternative except there would be no river water pump noise.
Room Temperature Operation	Same as the Preferred alternative. The APT site noise could be slightly less with room-temperature technology, because there would be no cryogenics facilities.
Lithium-6 Feedstock Material	Same as the Preferred alternative.
Inductive Output Tube	Same as the Preferred alternative.

**4.2.1.1 Construction**

DOE has reviewed the activities to be completed during construction and has identified the following as the primary impacts during this phase:

- Increased traffic-related accidents for both the public and site workers
- Increased exposure to nonradiological constituents for both the public and site worker
- Increased incidence of occupational injuries to workers

DOE used traffic statistics for public highways near the SRS to determine the normal accident rates for the public and site workers combined for existing traffic patterns. DOE then estimated the increase in traffic from construction activities and calculated the relative increase in accidents that could occur due to the greater number of vehicles on the roadways.

Section 4.1.3 discusses the methods used by DOE to calculate exposure of workers and the public to nonradiological constituents. As shown in Tables 4-7 and 4-8, the concentrations to which workers or the public could be exposed are well below regulatory limits and thus are expected to pose no health impact. In addition, these estimated concentrations do not vary markedly by alternative.

DOE estimated impacts on the worker population from occupational injuries using historic information at the SRS. First, DOE obtained the normal incidence rate (the number of injuries for a given number of work hours) of three categories of injuries: injuries requiring first aid, injuries requiring medical attention, and injuries resulting in lost work time. DOE then projected the total number of person-hours to build the APT facilities and calculated the expected number of injuries using the historic incidence rates.

Table 4-21 lists expected construction impacts on the health of site workers and the public.

**Table 4-21. Impacts on public and workers from construction of APT facilities.**

Factor	Percentage differences of impacts for alternatives							
	Results for Preferred alternative	Cooling water system			Accelerator technology	Feedstock Material	Radio-frequency power	Site location
		Once-through cooling with river water	Cooling towers with groundwater makeup	K-Reactor cooling tower with river water makeup	Room temperature	Lithium-6 aluminum alloy	Inductive output tube	Alternate site
Maximum increased traffic accident fatalities	2.2	NC <sup>a</sup>	NC	-7%	-6%	-9%	NC	-20%
Number of worker injuries requiring first aid	1,100	NC	NC	-7%	-6%	-9%	NC	NC
Number of worker injuries requiring medical attention	280	NC	NC	-7%	-6%	-9%	NC	NC
Number of worker injuries resulting in lost work time	93	NC	NC	-7%	-6%	-9%	NC	NC

a. NC = Difference in impacts between this alternative and the Preferred alternative is less than 5 percent.



The table lists vehicle accident and occupational injury information for the preferred configuration, and changes in the impacts if DOE implemented other alternatives. The data in the table indicate some changes in construction impacts for the Room Temperature Operation and Lithium-6 Feedstock Material alternatives; these changes would be due almost entirely to differences in the number of workers and labor hours spent to construct the facility.

#### 4.2.1.2 Operations

**Impacts to the Public.** DOE has considered the activities that would be performed following construction of the APT facilities and has identified potential impacts to the public in the following areas:

- Exposure to radiation, radioactive material, or nonradioactive material from facility emissions
- Transportation of radioactive material
- Exposure to increased traffic conditions on roads near the SRS with potential increased accident frequencies
- Exposure to electromagnetic fields (EMF)

To estimate impacts to the public from facility emissions, DOE used water and air quality data from Sections 4.1.2 and 4.1.3 to calculate the radiation dose to the maximally exposed individual and the public surrounding the SRS.

After DOE calculated the total radiation dose to the public from all sources associated with the accelerator, it used dose-to-risk conversion factors established by the National Council on Radiation Protection and Measurements (NCRP) to estimate the number of latent cancer fatalities that could result from the calculated exposure. No data indicate that small radiation doses cause cancer; to be conservative, however, the NCRP assumes that any amount of radiation carries some risk of inducing cancer. DOE has adopted the NCRP factors of 0.0005 latent cancer fatality for each person-rem of ra-

diation exposure to the general public and 0.0004 latent cancer fatality for each person-rem of radiation exposure to radiation workers (NCRP 1993).

Similar to radiological emissions, DOE used the air quality and water quality data in Section 4.1.2 and 4.1.3 to evaluate potential impacts to the public from nonradiological material. Of the materials expected to be released from the APT facilities, only Beryllium is a carcinogen. For noncarcinogenic material, DOE evaluated the material concentrations against concentration limits set by the State or Federal government to protect the public against other potential health effects (e.g., irritation of the lungs). The limits represent a conservative threshold below which no health effects would occur. As demonstrated in Sections 4.1.2 and 4.1.3, all concentrations for noncarcinogenic materials are well below any regulatory limits and DOE therefore expects no health impact.

For the special case of Beryllium emitted by the air pathway, DOE used the EPA's Integrated Risk Information System (IRIS) data base to estimate the increased risk of cancer from exposure to airborne Beryllium. Using the slope factor of 0.0024 per microgram per cubic meter, DOE calculated a risk of an additional lifetime latent cancer risk of  $4.6 \times 10^{-9}$  to the maximally exposed individual for the concentration listed in Table 4-10. This value is well below the 0.000001 risk value that EPA typically uses as the threshold of concern.

To determine the potential radiation exposure to the public from transportation of radioactive material, DOE first identified the types of shipments it would make as follows:

1. Onsite transportation of low-level radioactive waste (primarily job-control waste)
2. Onsite transportation of Tritium (Helium-3 Feedstock Material alternative)
3. Onsite transportation of irradiated Lithium-6 rods (Lithium-6 Feedstock Material alternative)

4. Offsite transportation of mixed waste (irradiated lead)
5. Offsite transportation of low-level radioactive waste (window modules, steel shielding, aluminum and irradiated tungsten)

DOE analyzed onsite transportation of low-level radioactive waste in detail as part of the SRS Waste Management EIS (DOE 1995b). The APT will produce some radionuclides that are different (i.e., not beta-gamma emitting) than those analyzed previously; however, these radionuclides represent a small fraction (less than 1 percent) of the total inventory. Therefore, DOE believes that the impacts presented in the SRS Waste Management EIS for onsite transportation of low-level radioactive waste are representative of those from the transportation of waste associated with the APT facilities.

For transportation of the other material types listed above, DOE determined the radiation dose rate from the various transport packages and then used the RADTRAN computer program to estimate the consequences to the public from incident-free transportation. DOE has not postulated a reasonably foreseeable transportation accident for these materials because they would all be transported in Type B packages, which are designed to maintain their contents in severe accidents.

Similar to the methodology described for construction impacts, DOE calculated the anticipated traffic accidents attributable to APT operations by using historical information on traffic accidents on roads near the SRS. DOE then applied this rate to the expected traffic associated with APT operations to estimate the number of traffic accidents.

Table 4-22 lists projected health impacts from routine operation of the APT facilities. The table lists radiological dose information and traffic information for the preferred configuration; it also lists changes in the expected impacts for the alternatives.

*Impacts to Workers.* DOE has considered the activities that it would perform following construction of the APT facilities and has identified potential impacts to workers in the following areas:

- Exposure to radiation, radioactive material, and nonradioactive material from facility operations
- Exposure to radiation from transportation of radioactive material
- Exposure to occupational injuries
- Exposure to electromagnetic fields in the facilities
- Exposure to increased traffic conditions on roads near the SRS with potential increased accident frequencies

DOE based its estimates of radiation doses to workers on historic experience at the Tritium Facilities in H-Area. In addition, DOE reviewed the design of the APT facilities and estimated the likely radiation dose rates from the components. DOE then projected the number of workers who could be exposed to determine the total dose to workers and the maximum dose to an individual worker. Using the air quality data in Section 4.1.3, DOE also calculated the radiation dose to an uninvolved worker (one not associated with APT operations and not on the APT site) who receives a dose from radiological emissions from the APT stacks.

Based on the conceptual design of the accelerator, DOE does not expect workers in the facilities to be exposed to other than incidental concentrations of airborne nonradioactive material, primarily in the form of cleaning agents. Therefore, DOE did not perform a detailed analysis of health effects from exposure to non-radiological material inside the facility. However, similar to the calculation of the radiologi-

Table 4-22. Impacts on public health from normal operation of APT facilities.

Factor	Impacts for Preferred alternative	Percentage differences of impacts for alternatives						
		Cooling water system			Accelerator technology	Feedstock Material	Radio-frequency power	Site location
		Once-through cooling using river water	Cooling towers with groundwater makeup	K-Reactor cooling tower with river water makeup	Room temperature	Lithium-6 aluminum alloy	Inductive output tube	Alternate site
Annual radiation dose to MEI from APT emissions (millirem/year) <sup>a,b</sup>	0.042	NC	NC	NC	NC	-52%	NC	+45%
Annual radiation dose to MEI from transportation of radioactive material (millirem/year)	2.8×10 <sup>-6</sup>	NC <sup>c</sup>	NC	NC	NC	+11%	NC	NC
Total annual radiation dose to MEI from APT operations (millirem/year)	0.042	NC	NC	NC	NC	-52%	NC	+45%
Annual radiation dose to population from APT emissions (person-rem/year)	1.3	+11%	NC	NC	NC	-46%	NC	+8%
Annual radiation dose to population from transportation of radioactive material (person-rem/year)	1.1	NC	NC	NC	NC	NC	NC	NC
Total annual radiation dose to population from APT operations (person-rem/year)	2.4	+6%	NC	NC	NC	-25%	NC	NC
Estimated number of cancer fatalities from annual population dose	0.0012	+6%	NC	NC	NC	-25%	NC	NC
Estimated traffic accident fatalities per year on roads near SRS	0.12	NC	NC	NC	NC	NC	NC	-18%

a. Reported as the sum of the dose from air emissions and liquid emissions, even though the MEI for the two emissions are in different locations.

b. MEI - maximally exposed individual.

c. NC = Difference in impacts between this alternative and the Preferred alternative is less than 5 percent.

cal dose to workers, DOE calculated the air concentration an uninvolved worker, as discussed above, could receive from emissions at the APT site. Of the airborne constituents released from the APT facilities, only Beryllium is a carcinogen. DOE calculated the risk of cancer to the uninvolved worker using the same methodology described above for public exposure to Beryllium. Using the same slope factor of 0.0024 per microgram per cubic meter, the calculated risk to the worker would be  $6.7 \times 10^{-8}$  which is well below the threshold of  $1.0 \times 10^{-6}$ .

To determine the impacts from transportation of radioactive material, DOE used the methodology described above for determining impacts to the public, but it chose the receptors of interest to be a maximally exposed worker and the worker population. DOE calculated the doses to these receptors for the same types of shipments described above and lists the results in Table 4-23.

To estimate the number of occupational injuries that could occur during normal APT operations, DOE multiplied the SRS injury rate by the estimated work-hours per year for three types of injuries: those requiring first aid, those requiring medical attention, and those resulting in lost work time.

Workers could be exposed to electromagnetic fields in and near the APT facilities. These fields would come from such sources as power lines, large electric motors, and radiofrequency tubes. The primary frequencies of the sources would be less than 1,000 megahertz, which is lower than the frequency of visible light. At these frequencies, electromagnetic waves have not been shown to cause cancer (American Cancer Society 1997). Therefore, DOE compared expected EMF levels to exposure limits set by the Occupational Safety and Health Administration ( $10 \text{ mW/cm}^2$  for periods of 0.1 hour or more, 29 CFR 1910.97) and expects no health impacts under normal operation.

As discussed above, DOE calculated increased incidents of traffic accidents based on historic

information coupled with expected traffic associated with APT operations. The values presented in Table 4-22 are the estimated total number of accidents attributable to APT operation and reflect total accidents for workers and the public.

Table 4-23 lists estimated impacts on workers for normal operating conditions. The table indicates that impacts would not vary much among the alternatives; however, some variations would occur as a result of the size of the work force for a particular alternative.

#### 4.2.1.3 Accidents

All accidents with a postulated frequency of less than once during the operating life of the accelerator (40 years) have negligible consequences. Only four low-probability accidents (highest frequency = once per 2,000 years) have offsite doses high enough to warrant public protective actions under the SRS Emergency Plan (1 rem at site boundary) (WSRC 1996c).

This section summarizes risks to members of the public and workers from facility accidents associated with the operation of the APT. This EIS defines an accident as a series of unexpected or undesirable events possibly leading to a release of radioactive or hazardous material in the facility or to the environment; however, not all accidents result in a release. Each alternative discussed in this EIS has the potential for accidents.

All accidents have several things in common, as shown in Figure 4-1: a hazard (radioactive material, hazardous chemicals, etc.) and an energy source to breach protective barriers. The barrier to a release can be a single item or a combination of many items; for example, a tank of material inside a vault inside a storage facility would have three barriers -- the tank wall, the walls of the vault, and the walls of the storage facility. In addition, the physical form of the material can act as a barrier to its release. For this example to have a release to the environ-

**Table 4-23. Impacts on worker health from operation of APT facilities.**

Factor	Percentage of difference of impacts for alternatives							
	Impacts for Preferred alternative	Cooling water system			Accelerator technology	Feedstock Material	Radio-frequency power	Site Location
		Once-through cooling using river water	Cooling towers with groundwater makeup	K-Reactor cooling tower with river water makeup	Room temperature	Lithium-6 aluminum alloy	Inductive output tube	Alternate site
Annual maximum radiological dose to worker from facility operation (rem)	1	NC <sup>a</sup>	NC	NC	NC	NC	NC	NC
Annual total radiological dose to all workers from APT operation (person-rem)	72	NC	NC	NC	NC	-7%	NC	NC
Annual total radiological dose to all workers from transportation of radioactive material (person-rem)	16	NC	NC	NC	NC	+63%	NC	NC
Estimated number of cancer fatalities from annual total dose	0.04	NC	NC	NC	NC	NC	NC	NC
Number of worker injuries requiring first aid (cases per year)	19	NC	NC	NC	NC	-5%	NC	NC
Number of worker injuries requiring medical attention (cases per year)	2.8	NC	NC	NC	NC	-5%	NC	NC
Number of worker injuries resulting in lost work time (cases per year)	1.4	NC	NC	NC	NC	-5%	NC	NC
Number of workers exposed to electromagnetic fields	100	NC	NC	NC	NC	NC	NC	NC
Magnitude of EMF to which workers are exposed (mW/cm <sup>2</sup> )	1.2@350MHZ 2.3@700MHZ	NC	NC	NC	NC	NC	NC	NC

a. NC = Difference in impacts between this alternative and the Preferred alternative is less than 5 percent.

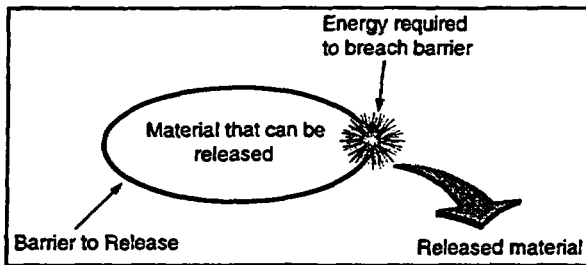

Figure 4-1. An accident resulting in a release of material.

ment, an accident would have to have enough energy to breach all three barriers.

In most cases, breaching a barrier will not result in the release of all of the hazardous material. The nature of the accident will control the amount of material released. This analysis takes this into account by using the estimated release fraction, which is the fraction of material that DOE has calculated the accident would release. After its release to the environment, a material undergoes dilution similar to releases from routine operations.

The purpose of accident analyses is to determine two crucial pieces of information: the frequency (or probability) of an accident and the consequences of that accident if it occurred. This analysis based the estimated frequency of an accident on calculated failures that must occur for the accident to happen; that is, an accident usually requires a number of events to happen in sequence, and the overall probability is the product of the probabilities for the independent individual events. The consequence of the accident is usually related to the human health of the workers and public surrounding the facility; this analysis based its calculated consequences on the assumed amount of released material and the location of workers and the public. For radiological accidents, the analysis first calculated consequence as a radiation dose, and then based its determination of the health effects on the dose. For chemical accidents, the analysis calculated the concentration to which people are exposed, and then determined the health effects.

DOE analyzed the hazards from the operation of the proposed facility and the associated barriers to prevent release of the hazards. In addition, to identify the probability for and the magnitude of a release if it occurred, DOE identified possible energy sources that could be available to breach the barriers. DOE also assessed the likelihood of each event (probability per unit time) based on Departmental guidance documents. Table 4-24 summarizes potential significant events. Appendix B describes individual accident assumptions. Among those accidents postulated but not considered credible or significant were airplane crashes and site flooding enhanced by upstream dam failure. The key portions of the APT are underground and the facility is located well away from the nearest commercial airport. As for flooding, the APT preferred site is on a bluff over 100 feet above the nearest flood plain.

Table 4-24 lists the information on each potential accident as follows:

- *Event description:* The accident identifier (i.e., a name for the accident). In most cases, it is the major event in the sequence that would lead to the release, although it is not necessarily the first or the last event in the sequence.
- *Hazard:* The material that could be released. Most hazards listed are radioactive material; however, some accidents involve the release of chemicals. This column lists the type and location of the hazard (e.g., target, tunnel).
- *Barrier breached:* The primary barrier the accident would breach. Although there could be other barriers, this column lists the first barrier the material encounters to enable a better understanding of the concept of accident analysis.
- *Energy for release:* The source of energy that breaches the barrier; that is, the circum-

Table 4-24. General information on accidents associated with APT facilities.

Event	Hazard	Barrier	Driving force	Dominant Materials	Calculated accident frequency
<b>Accidents applicable to all alternatives</b>					
Target cooling pump failure	Radioactive materials in target	Cooling piping for target	Residual heat from target	Negligible <sup>a</sup>	Once per 6 years
Loss of secondary cooling	Radioactive materials in target	Cooling piping for target	Residual heat from target	Negligible	Once per 6 years
Chemical releases	Hazardous chemicals	Chemical containers	Container breach assumed with evaporation	Hydrofluoric acid, hydrazine, ammonium hydroxide	Once per 10 years
Tunnel purge of normally activated air without delay	Activated tunnel air	Air confinement system	Air Handling System	Negligible	Once per 100 years
Resin bed fire	Radioactive materials filtered from cooling system	System piping	Fire	H-3, O-15, C-11, N-13	Once per 100 years
Cooling pipe break in target	Radioactive materials in target	Cooling piping for target	Residual heat from target	O-15	Once per 1,000 years
Full power beam/beam stop interaction	Radioactive materials in beam stop	Containment around beam stop	Beam energy	C-11, Be-7, H-3	Once per 10,000 years
Misdirection of beam with loss of confinement	Radioactive materials in accelerator tube wall	Physical form of material	Beam impingement	N-13, O-15, Ar-41, C-11	Once per 10,000 years
Target handling accident	Radioactive materials in target	Target cladding	Residual heat in target	Negligible	Once per 10,000 years
Beam expander failure	Radioactive materials in target	Target cladding	Beam energy	Negligible	Once per 100,000 years
<b>Additional accidents for Helium-3 Feedstock Material only</b>					
Small fire in Tritium Separation Facility	Tritium in facility	Containment systems	Fire	H-3	Once per 100 years
Large fire in Tritium Separation Facility	Tritium in facility	Containment systems	Fire	H-3	Once per 10,000 years
Design-basis seismic event	Tritium in facility and activated air in beam tunnel	Containment systems	Fire and beam tube	H-3, N-13, Ar-41, O-15, C-11	Once per 2,000 years
Seismic event beyond design basis	Various radioactive materials	Containment systems	Thermal energy	H-3, O-15, C-11	Less than once per 100,000 years
Failure to shut down beam during transient	Various radioactive materials	Containment systems	Beam energy	Negligible	Less than once per 1 million years
<b>Additional accidents for Lithium-6 Feedstock Material only</b>					
Design-basis seismic event	Tritium in facility and activated air in beam tunnel	Containment systems	Fire and beam tube	H-3, N-13, Ar-41, O-15, C-11	Once per 2,000 years
Seismic event beyond design basis	Various radioactive materials	Containment systems	Thermal energy	H-3, O-15, C-11	Less than once per 100,000 years
Failure to shut down beam during transient	Various radioactive materials	Containment systems	Beam energy	Negligible	Less than once per 1 million years

a. "Negligible" means that DOE does not expect release of a measurable amount of material.

stance that is immediately responsible for the barrier failure.

- *Dominant materials:* Major components of the released materials. For radiological releases, it lists major radionuclides; for chemical releases, it identifies the chemicals (see Appendix B).
- *Calculated accident frequency:* Calculated value for the likelihood that the accident would occur. DOE estimated these values by identifying events that would have to occur for the accident to progress and then calculating the frequency for each of the events. The product of the individual frequencies is the overall probability for the entire accident.

During the analysis, DOE determined that most major accidents would not depend on implemented alternatives; events that would lead to releases would rely on systems and features common to almost all alternatives. However, the Preferred alternative for the accelerator includes the Helium-3 feedstock material, which would require the associated Tritium Separation Facility. For the Lithium-6 feedstock material, DOE would not build the TSF (see Chapter 2); therefore, accidents that occurred in the TSF would not be possible if DOE implemented the Lithium-6 feedstock material alternative. Therefore, Tables 4-24 and 4-25 list accidents that would be unique to the Helium-3 and Lithium-6 feedstock material alternatives separately. The other listed accidents would be applicable to all facility alternatives (i.e., operating temperatures, sources of electrical power, sources of cooling water, or radiofrequency tubes). If the TEF were colocated with the TSF, any accidents for the combined facility would be bound by this analysis.

DOE analyzed each accident scenario to determine the quantity of hazardous material that would be present in the facility and the amount that would be available for release to the environment, and used these values in a computer model that calculated the effects of transporting

the material through the atmosphere and the radiation doses at selected locations. DOE calculated the dose to three receptors:

- The offsite maximally exposed individual at the SRS boundary
- An uninvolved worker at the Savannah River Site, not associated with APT operations and at least 640 meters from the accident site
- Members of the public within 50 miles of the facility (population = 620,000)

DOE performed accident calculations for the preferred site (6.38 miles to the SRS boundary) and for the alternate site (3.8 miles to the SRS boundary). As the administrative limits for radionuclide inventory are adjusted for site location, there is essentially no difference in accident consequences between the preferred and alternate sites. However, as the preferred site is farther from the site boundary, the projected radionuclide inventory limit could be higher allowing greater operational flexibility.

The increased number of latent cancer fatalities to the public, as discussed in Section 4.2.1.4, is 0.0005 times the dose in person-rem for doses less than 20 rem. For larger doses, when the rate of exposure would be greater than 10 rads per hour, the increased likelihood of latent cancer fatality is doubled, assuming the body's diminished capability to repair radiation damage. DOE calculated the expected increase in the number of latent cancer fatalities above those expected for the population, and has listed these values and other accident consequence data in Table 4-25.

In general, DOE performed dose calculations for a 1-year exposure period (i.e., people would be exposed to the released materials for 1 year following the accident). However, the SRS Emergency Plan (1) follows the EPA Guidelines and (2) recommends evacuation of affected people when committed dose is greater than 1 rem. Therefore, if the projected local dose



Table 4-25. Calculated accident consequences for accidents listed in Table 4-24 for preferred APT site.

Event	MEI dose (rem)	Population dose (person-rem)	Uninvolved worker dose (rem)	Cancer fatalities in population	Calculated accident frequency
<b>Accidents applicable to all alternatives</b>					
Target cooling pump failure	Negligible <sup>a</sup>	Negligible	Negligible	Negligible	Once every 6 years
Loss of secondary cooling	Negligible	Negligible	Negligible	Negligible	Once every 6 years
Chemical releases	Negligible	Negligible	Negligible	Negligible	Once every 10 years
Tunnel purge of normally activated air without delay	Negligible	Negligible	Negligible	Negligible	Once every 100 years
Resin bed fire	0.50	800	75	0.40	Once every 100 years
Cooling pipe break in target	0.03	57	2.8	0.029	Once every 1,000 years
Full power beam/beam stop interaction	0.0043	5.0	0.96	0.0028	Once every 10,000 years
Misdirection of beam with loss of confinement	0.000012	0.057	0.00078	0.000029	Once every 10,000 years
Target handling accident	Negligible	Negligible	Negligible	Negligible	Once every 10,000 years
Beam expander failure	Negligible	Negligible	Negligible	Negligible	Once every 100,000 years
<b>Additional accidents for Helium-3 Feedstock Material only</b>					
Small fire in Tritium Separation Facility	0.21	360	7.0	0.18	Once every 100 years
Large fire in Tritium Separation Facility	1.9	3,500	8.1	1.7	Once every 10,000 years
Design-basis seismic event	2.9	5,100	150	2.6	Once every 2,000 years
Seismic event beyond design basis	3.0	5,500	168	2.7	Less than once every 100,000 years
Failure to shut down beam during transient	Negligible	Negligible	Negligible	Negligible	Less than once every 1 million years
<b>Additional accidents for Lithium-6 Feedstock Material only</b>					
Design-basis seismic event	0.96	1,600	146	0.8	Once every 2,000 years
Seismic event beyond design basis	1.7	3,100	200	1.6	Less than once every 100,000 years
Failure to shut down beam during transient	Negligible	Negligible	Negligible	Negligible	Less than once every 1 million years

a. "Negligible" means that DOE expects no quantifiable health impact.

would be greater than 1 rem, DOE calculated the doses to the maximally exposed individual and the uninvolved worker for 1 day of exposure, instead of 1 year of exposure.

#### 4.2.2 ECOLOGY

This section evaluates potential impacts of construction and operation of the APT on the ecological resources of the SRS.

##### 4.2.2.1 Terrestrial Ecology

Potential impact to terrestrial ecology would result from the clearing of 250 acres (additional land would be required for the modular design variation) of forested land at either site. DOE does not expect, however, that this would create a long-term reduction in the local or regional diversity of plants and animals. Plant stress from salt deposition from cooling tower operations would be negligible.

**Construction.** DOE identified the following potential impacts on terrestrial vegetation and wildlife in evaluating the actions it would have to complete during construction:

- Removal of vegetation that provides wildlife habitat
- Displacement of mobile wildlife from construction areas
- Loss of less mobile wildlife in construction areas
- Loss of wildlife from wildlife-vehicle collisions

The preferred and alternate sites for construction are predominantly forested with stands of loblolly and slash pine and small upland hardwood stands of white oak, red oak, and hickory. Construction activities would result in the clearing, grading, or disturbance of approximately 250 acres at either of these sites (Shedrow 1997b). Construction activities would affect virtually all vegetation in this area. The

Savannah River Institute (formerly known as the Savannah River Forest Station) would coordinate the removal and sale of marketable timber; however, clearing and grading would disturb the remaining understory vegetation. In addition, every alternative would include the clearing of about 30 acres for pipelines, and associated facilities (substations and pumping stations) and a smaller amount of land for the construction of roads and a rail line (Shedrow 1997b). DOE has not identified any unique or sensitive plants (or plant communities) at the preferred or alternate site or in the probable corridors for infrastructure expansion. Therefore, DOE does not expect a reduction in the local or regional diversity of plants and plant communities during construction for any alternative. (See Section 4.2.2.4 for discussion of threatened and endangered species.)

Impacts to wildlife would vary during construction. As the site underwent clearing and grading, disturbance and habitat loss would displace more mobile animals (birds and larger mammals). Some of these animals, particularly young individuals, could be killed by predators and automobiles, or could be forced to occupy less suitable habitat. Species -- including raccoons, opossums, eastern cottontails, red-tailed hawks, screech owls, blue jays, and common crows that can adapt to disturbed or developed areas -- would recolonize the site as construction ended and site conditions became stable (Mayer and Wike 1997). Other animals would be displaced permanently, dispersing from the site to the surrounding area. Species more dependent on forested habitat or more sensitive to disturbance (e.g., birds such as wood warblers and vireos) probably would be permanently displaced.

Clearing and grading the site would result in the loss of some individuals, primarily less mobile animals such as toads, turtles, lizards, snakes, mice, moles, and voles. Some small mammal losses would also result as individuals become more vulnerable to predation as a result of displacement. Because these animals are common throughout the SRS, DOE expects negligible

reduction in their populations as a result of construction.

Increased traffic on roads during construction is likely to result in increased wildlife-vehicle collisions, which would result in the loss of mammals such as the gray squirrel, opossum, and white-tailed deer, as well as reptiles and amphibians such as snakes and toads. Because these animals are common throughout the SRS, DOE expects their populations to be unaffected by these losses.

**Operations.** DOE has evaluated the following potential impacts on terrestrial vegetation and wildlife during operation of the APT facilities:

- Stress or loss of vegetation due to salt deposition from cooling tower operation
- Displacement of wildlife near the APT site due to noise
- Loss of wildlife due to wildlife vehicle collisions

During operation, impacts to terrestrial vegetation could result from salt deposition attributable to drift from mechanical- or natural-draft cooling towers. Cooling-tower drift can cause vegetation stress through direct deposition of salts on foliage or through excess accumulation of salts in the soil (NRC 1985). Salt stress in plants can occur through a number of mechanisms, including (1) the increased osmotic potential of the soil solution, which affects the availability of moisture in the soil to the plant; (2) an alteration of the mineral nutrition balance in plant tissues; and (3) toxic effects due to increases in specific ion concentrations in the plants (DOE 1987a).

The tolerances and susceptibilities of plants to salt deposition are highly variable, depending on the species and environmental conditions. In vegetative studies, the threshold for visible salt stress symptoms on the most sensitive species occurred at approximately 183 pounds of sodium chloride per acre per year (INTERA 1980). Deposition rates of about 90.4 pounds

of sodium chloride per acre per year can reduce agricultural productivity (Mulchi and Armbruster 1981).

Modeling results indicate that maximum total deposition rates for solids would depend on the cooling tower type and the source of cooling water. However, the maximum reported deposition rate for any alternative would be 60 pounds per acre per year. Even if the solids consisted entirely of sodium chloride, this deposition rate would be less than the amount that would be expected to cause damage to vegetation; therefore, salt deposition should cause negligible impacts on vegetation.

Every alternative would involve noise from the operation of APT facilities, trains on the rail spur to the facility, and vehicle traffic. In general, animals habituate to a regular predictable noise, or one of a continuous nature, more readily than to sporadic noise bursts (Golden et al. 1980). The noise sources identified in Section 4.1.6.2 should have negligible impacts on wildlife in the area around either APT site because they would be relatively constant or local to the site such that sounds would decrease below critical levels before they could reach the facility boundary. Species that can adapt to human disturbance would recolonize portions of the site (the open grassy areas) despite the noise level. Birds such as killdeer, common bobwhite, and eastern meadowlark could nest in the open fields and weedy graveled areas while species such as mourning dove, northern mockingbird, and eastern bluebird could forage in the area. Predatory species such as rat snake, red-tailed hawk, and gray fox probably could hunt in the open grassy areas, taking advantage of expanding small mammal populations. Mammals such as raccoons, opossums, and skunks would also likely frequent the area, possibly establishing dens and territories in and around the buildings (Mayer and Wike 1997).

Increased traffic on roads near the APT facilities probably would result in increased wildlife-vehicle collisions, which could result in the loss of mammals such as the gray squirrel, opossum, and white-tailed deer, as well as frogs, turtles,

and snakes. These animals are common throughout the SRS, and their populations would be unaffected by these small losses.

#### 4.2.2.2 Aquatic Ecology

The withdrawal of Savannah River water for cooling would result in the impingement of adult fish and the entrainment of fish eggs and larvae at the river water intake. The Once-Through Cooling Water alternative would result in considerably higher rates of impingement and entrainment than the various cooling tower alternatives, but losses of adult fish, fish eggs, and fish larvae under all alternatives would be small relative to total fish production in the upper and middle reaches of the Savannah River.

Heated effluent from the APT facility would be discharged to either Indian Grave/Pen Branch or the pre-cooler ponds and Par Pond. Discharge temperatures under the Once-Through Cooling Water alternative would be high enough to cause limited fish kills in the pre-cooler ponds. Fish kills in Indian Grave/Pen Branch and the pre-cooler ponds are unlikely under the other cooling water alternatives.

**Construction.** As discussed above, surface water impacts from construction activities would be minor, and similar for all alternatives. DOE would use appropriate soil and erosion control measures to protect Upper Three Runs and its tributaries; such measures could include silt fences, spray-on adhesives, and seeding areas thought to be prone to erosion. As a consequence, impacts from erosion and sedimentation to aquatic organisms in Upper Three Runs and its tributaries would be minor, and would not be a concern after DOE had stabilized and revegetated disturbed areas.

**Operations.** Depending on the alternative selected, the APT facilities would withdraw water from the Savannah River for once-through cooling or for cooling tower makeup water. Chapter 2 discusses anticipated rates of withdrawal from the river for the various alternatives. The APT tertiary cooling water system would discharge thermal effluent or cooling

tower blowdown to either Par Pond (through Ponds 2, 5, and C) or Pen Branch (through Indian Grave Branch). The following sections discuss potential impacts to (1) Savannah River biota from river water withdrawal and (2) the aquatic communities of the Par Pond system (including the pre-cooler ponds) and the Pen Branch-Indian Grave Branch system from APT nonradioactive liquid discharges.

**Impingement and Entrainment.** Section 316(b) of the Clean Water Act (33 USC 1326) directs the Environmental Protection Agency to establish standards that require "...the location, design, construction, and capacity of cooling water intake structures reflect the best technology available for minimizing adverse environmental impacts...." Section 316(b) studies or "demonstrations" assess potential impacts to aquatic communities from impingement and entrainment at the process or cooling water intakes of industrial facilities and powerplants, and are often a condition of a National Pollutant Discharge Elimination System (NPDES) permit or permit renewal.

As a condition of NPDES permit SC0000175, issued in October 1976, the Environmental Protection Agency required DOE to conduct Section 316(b) studies to evaluate the impingement of juvenile and adult fish on river water intake (trash) screens and the entrainment of fish eggs and larvae into the river water pumping system. Three of the five SRS production reactors (P, K, and C-Reactors) operated during most of the study period. Based on biweekly observations of fish impinged at the river water intake screens, an estimated 7.3 fish per day (2,680 fish per year) were impinged at the river water intakes (McFarlane, Frietsche, and Miracle 1978). The most commonly impinged species were bluespotted sunfish, warmouth, channel catfish, and yellow perch. Assuming "worst-case conditions," an estimated 6.8 million eggs and 19.6 million larvae were lost annually to entrainment, representing 9.5 and 9.1 percent, respectively, of the total number of fish eggs and larvae moving past the cooling water intakes during the April-May-June (peak) spawning period (McFarlane, Frietsche, and Miracle

1978). American shad comprised 96 percent of the fish eggs collected. Blueback herring and three shad species (American, gizzard, and threadfin) dominated the larval fish collections, along with large numbers of spotted sucker and black crappie.

DOE conducted additional impingement and entrainment studies from 1983 through 1985 to assess potential impacts of the restart of L-Reactor. The 1983-1985 studies showed that an average of 7,603 fish were impinged annually on river water intake screens (DOE 1987b). Entrainment losses averaged about 10 million eggs and 18.8 million larvae annually. The species affected most by impingement were bluespotted sunfish and threadfin shad; entrainment losses were primarily American shad and other clupeids. The study concluded that "these losses do not appear to have a significant impact on the Savannah River fisheries, therefore no mitigation seems justified" (DOE 1987b).

In early 1988, when three production reactors (K-, L-, and P) last operated, the maximum rate of river water withdrawal at the 1G and 3G intakes was about 380,000 gallons per minute, or 179,000 gallons per minute each for once-through cooling at K- and L-Reactors and 22,000 gallons per minute for makeup water at P-Reactor. Based on the studies described above, DOE estimated that continued operation of K-, L-, and P-Reactors would result in the entrainment of an estimated 18 million fish larvae and 9 million fish eggs annually during the spring and summer spawning period. Clupeid (shad and herring), centrarchid (sunfish and crappie), and cyprinid (minnow and common carp) larvae would be entrained most often, while eggs of two anadromous species, American shad and striped bass, would be entrained most often. The *Final Environmental Impact Statement Continued Operation of K-, L-, and P-Reactors* concluded that impacts to fisheries from entrainment of fish eggs and larvae at the SRS would be small and limited to fish populations in the immediate vicinity of the Site (DOE 1990).

Since 1988 there has been a dramatic reduction in the rates of water withdrawn from the Savannah River by the SRS. By the end of 1988, DOE had shut down the SRS production reactors or placed them in cold standby, and was reviewing their future status. By 1996, all five reactors were shut down permanently.

In 1993, DOE placed Pumphouse 1G in "layup" (unused but routinely inspected and maintained), and in 1995 deactivated and abandoned Pumphouse 6G (on Par Pond). In June 1996 only one of the 10 pumps in Pumphouse 3G was operating, pumping approximately 28,000 gallons per minute to maintain L-Lake water levels; auxiliary equipment cooling in K-, L-, and P-Areas; fire protection in K-, L-, and P-Areas; and sanitary wastewater in K-, L-, and P-Areas (DOE 1997a). In 1997, DOE installed a 5,000 gallon per minute pump in the 3G pumphouse to conserve energy and reduce costs, and shut down the last large capacity pump that was still in service.

Under the Preferred alternative, the preferred cooling water alternative would be the Mechanical-Draft Cooling Tower with river water makeup. Based on the results of the 1983-1985 impingement and entrainment studies (DOE 1987b) and assuming impingement and entrainment rates are proportional to river water withdrawal rates, the anticipated 6,000-gallons per minute withdrawal of Savannah River water under the preferred cooling water alternative would result in the impingement of an estimated 132 fish and the entrainment of an estimated 173,000 fish eggs and 326,000 larvae annually (Table 4-26). Impingement and entrainment rates under the K-Area (natural-draft) Cooling Tower alternative would be essentially the same. Under the Once-Through Cooling alternative, DOE would withdraw an estimated 125,000 gallons per minute for cooling in the APT facilities. This would impinge an estimated 2,600 fish and entrain an estimated 3.4 million fish eggs and 6.4 million larvae annually, approximately one-third the rates of impingement and entrainment observed during the 1983-1985 period (DOE 1987b). To put these

Table 4-26. Estimated annual rates of impingement and entrainment for APT cooling water alternatives.<sup>a</sup>

Factor	Baseline	Natural-draft cooling tower	Mechanical-draft cooling tower	Once-through cooling
Rate of river water withdrawal (gallons per minute)	5,000	6,000	6,000	125,000
Annual impingement	110	132	132	2,600
Annual entrainment (eggs)	144,000	173,000	173,000	3,400,000
Annual entrainment (larvae)	272,000	326,000	326,000	6,400,000

a. Total annual impingement and entrainment losses for each cooling water alternative would be the sum of the baseline impingement/entrainment and the losses expected from the cooling water alternative selected.

entrainment rates in perspective, a single female American shad can produce 200,000 to 600,000 eggs per spawning season, and a single gizzard shad can produce as many as 500,000 eggs per spawning season (Scott and Crossman 1973). Therefore, withdrawal of river water under any of the cooling water alternatives would not have a significant impact on the fisheries of the Savannah River.

#### Non-radioactive Liquid Discharges.

**Thermal Effects.** Many blue-green algae are tolerant of high water temperatures, preferring temperatures above 95°F; a relatively large number of green algae species grow best at temperatures as high as 95°F; most diatoms prefer temperatures below 86°F (Patrick 1969). Therefore, periphyton ("attached" algae) communities could be altered by thermal discharges under the various cooling water alternatives. In general terms, dominance of the periphyton by a diverse diatom community indicates good water quality, while dominance by a few blue-green or green algae is often associated with poor water quality. When the SRS production reactors were operating, thermophilic blue-green algae (those that can grow and reproduce in warmer waters) often dominated the algal communities in waters that received thermal effluents (Gibbons and Sharitz 1974).

Under the Mechanical-Draft Cooling Tower alternative, maximum discharge temperatures to ponds 2 and 5 would range from 65 to 88°F, and would be highest in July and August. These discharges could affect the periphyton com-

munities of the Par Pond system, but changes in community structure probably would be subtle and difficult to detect outside of the immediate area of the discharge. Under the Once-Through Cooling alternative, discharge temperatures would increase steadily over the summer, ultimately reaching 102°F in July and August in Pond 2, 101°F in Pond 5, and 100°F in Pond C (see Section 4.1.2). Temperatures of this magnitude would favor growth and reproduction of green and blue-green algae and would likely displace species, such as diatoms, less tolerant of heated waters.

Because the 2,000-gallon-per-minute blowdown from the K-Area natural-draft cooling tower is not likely to exceed 89°F and represents only a 10-percent addition to the normal Pen Branch flow (see Section 4.1.2), the heated discharge probably would only affect attached algae communities in the 1-mile section of Indian Grave Branch below the discharge canal. Beyond the confluence of Pen Branch and Indian Grave Branch, impacts would be subtle to imperceptible.

Benthic macroinvertebrates are bottom-dwelling organisms (such as mollusks and insect larvae) that live part or all of their life cycles in and on various submerged substrates. Long-term changes in water temperature can influence the composition of the macroinvertebrate community because these organisms are usually unable to disperse rapidly, if at all, from areas of thermal influence and typically live in a water body over several seasons.

Thermal stress tends to reduce community diversity (the number of kinds of animals in a body of water) by making the environment unsuitable for intolerant species or by conferring competitive advantage to species that are able to tolerate large temperature changes. Howell and Gentry (1974) studied aquatic insect communities on the SRS and found increasing diversity from thermal to post-thermal to natural streams. Two species, a corixid (backswimmer) and a chironomid (midge larva), comprised almost 96 percent of individuals collected from a thermal stream; more stoneflies, dragonflies, mayflies, and caddisflies were found in the natural stream than the post-thermal or thermal stream.

Researchers have investigated temperature tolerances for certain groups of benthic macroinvertebrates, but the temperature preferences and limits of many other groups are unknown. Lethal temperatures for some sensitive stonefly and mayfly species are as low as 68°F, while those for some dragonfly species are as high as 105°F (Wiederholm 1984). In terms of community responses, field studies have shown that water temperatures above 86°F can cause a reduction in species richness, abundance, biomass, or production (Wiederholm 1984). Temperatures of 95 to 106°F eliminated virtually all aquatic insects from cooling water canals at powerplants (Durrett and Pearson 1975; Parkin and Stahl 1981).

The sublethal effect of temperature on aquatic macroinvertebrates might be more important than absolute tolerance to high temperatures. For example, increased temperatures can disrupt the normal seasonal emergence pattern of aquatic insects. Insects emerging too early in the season can be killed by low air temperatures or rendered more vulnerable to predation. Altering the normal sequence of male-female emergence can affect reproduction.

Under the preferred cooling water alternative (mechanical-draft cooling towers), maximum discharge temperatures to Ponds 2 and 5 would range from 65° to 88°F. The maximum tem-

perature observed in the canal entering Pond 2 over the 1994-1996 period, when unheated Savannah River water was pumped to Par Pond via Ponds 2 and 5 to maintain the water level in the reservoir, was 81°F (Cooney et al., 1995, 1996). The effect of heated discharges on benthic macroinvertebrates in summer is well documented. Temperatures higher than 86°F have been found to reduce numbers and diversity of benthos (Dahlberg and Conyers 1974; Wiederholm 1984). Therefore, the 88°F maximum discharge temperature to Ponds 2 and 5 would be expected to result in reduced benthic macroinvertebrate numbers and diversity in Ponds 2 and 5, but would probably have no discernible effect on Pond C or Par Pond.

Under the Once-Through Cooling alternative, discharge temperatures as high as 102°F would occur in July and August in Ponds 2 and 5. Temperatures as high as 100°F would occur in Pond C. Under these conditions, many benthic macroinvertebrates (e.g., caddisflies and mayflies) probably would undergo thermal stress and displacement by other forms, such as chironomid (midge) larvae, that are less affected by higher temperatures or reduced dissolved oxygen levels. Thus, community diversity would probably be reduced in these ponds, particularly during hot summer months. Benthic communities in Par Pond probably would be affected only near the Hot Dam, where water temperatures would be several degrees higher than normal.

Fish are cold-blooded vertebrates with body temperatures and physiologic functions that fluctuate approximately with the temperature of their environment. As environmental temperature increases, most metabolic processes become more rapid, up to a lethal temperature, at which metabolism ceases rapidly. Changes in temperature influence most physiologic processes, including feeding and nutrient assimilation, growth, development, and reproduction. Fish behavior is also influenced by temperature. Within their range of temperature tolerance, fish either seek or avoid heated waters.

A number of studies have defined thermal preferences and tolerance limits of fish, including many species indigenous to the Savannah River and its tributaries. Table 4-27 summarizes optimum spawning temperatures, temperature preferences, upper avoidance temperatures, and reported lethal temperatures for several important species in the middle reaches of the Savannah River and in SRS waters. While study objectives, techniques, and definitions varied among the studies cited, patterns of temperature tolerance are generally evident for the species. Temperature preferences and tolerance of the bluegill, a species that occurs in the pre-cooler ponds of the Par Pond system, are well known (see Table 4-27). The bluegill prefers temperatures between 81 and 91°F, and generally avoids temperatures higher than this. Thermal preferences for the largemouth bass, which is also common in the pre-cooler ponds, are similar to those of the bluegill (Table 4-27).

Other fish species likely to occur in the pre-cooler ponds include mosquitofish, minnows of the genus *Notropis*, bullheads, and redbreast sunfish (Bennett and McFarlane 1983; Aho and Anderson 1985; Wike et al. 1994). To evaluate the influences of the APT discharge on these species, DOE compared projected maximum discharge temperatures to upper avoidance and lethal temperatures of the various species. Table 4-28 lists the projected maximum temperatures during the summer in relation to upper

avoidance and lethal temperatures for the important species.

Under the preferred cooling water alternative (mechanical-draft cooling towers), the maximum temperature of discharges to Ponds 2 and 5 would be 88°F. This is high enough to produce an avoidance response in some fish species, but would not be high enough to kill resident fishes. Fish may be forced to seek out thermal refuges in late summer, areas within the ponds that are slightly cooler because they are deeper, or cooled by seeps and springs, or influenced by one of the small streams that flow intermittently into the ponds.

Maximum water temperatures in Ponds 2, 5, and C in late summer under the Once-Through Cooling alternative would be higher than those preferred by virtually all indigenous fish species, and could be high enough to kill more sensitive species. This is consistent with the observations of Aho and Anderson (1985), who studied the relationship between reactor operations and fish kills in Pond C. Fish kills in this cooling pond occurred in all months of the year, but tended to be more severe in late summer (when pond temperatures were highest and dissolved oxygen levels were lowest) and after extended reactor outages (when fish had recolonized areas that received the warmest water). Juveniles of all species tended to be more affected than adults.

Table 4-27. Temperature requirements of selected fish species of the Savannah River Site.

Species	Temperature (°F)			Lethal	Reference
	Spawning	Preferred	Avoidance		
Redbreast sunfish	68-82	68-86	—	—	Aho et al. 1986
Warmouth	70-81	77-86	—	—	McMahon et al. 1984
Bluegill	—	88	93	97	Peterson and Shutsky 1976
	63-81	82-91	—	97	Carlander 1977
	—	81-90	90-95	—	Coutant 1977
	—	—	—	104	Holland et al. 1974
Largemouth bass	—	81-90	84-93	—	Coutant 1977
	—	81-90	88-91	—	Carlander 1977
	—	—	—	97	Cvancara et al. 1977
	—	—	—	101	Drew and Tilton 1970
<i>Notropis</i> (3 species)	—	—	—	93 (winter)	McFarlane et al. 1976
	—	—	—	104(summer)	



**Table 4-28.** Comparison of maximum discharge temperatures in Ponds 2 and 5 and temperatures lethal to resident fish species.

Species	Avoidance	Lethal	Temperature (°F)	
			Ponds 2 and 5 predicted maximum (cooling towers)	Ponds 2 and 5 predicted maximum (once-through)
<i>Notropis</i> spp.	—	93-104	89	102
Bluegill	90-95	97-104	89	102
Largemouth bass	84-93	97-101	89	102

Based on the Pond C studies (Aho and Anderson 1985), fish kills could occur in Ponds 2 and 5 under two sets of circumstances. First, limited fish kills probably would occur in late summer when temperatures in Ponds 2 and 5 exceed known lethal limits for more sensitive species. Second, fish kills could occur at any time when DOE restarted the accelerator after an extended outage and water temperatures in the pre-cooler ponds rose suddenly.

In summary, discharge temperatures under the Once-Through Cooling alternative would be high enough to produce an avoidance response in fish in the pre-cooler ponds in summer months and could, under certain circumstances, result in fish kills. The severity and extent of these kills would depend on operational factors (e.g., timing and rate of power ascension when the APT facility restarts after an outage), weather (fish kills would be more likely if air temperatures were unusually high), and biological factors (e.g., species composition of Ponds 2 and 5 fish communities, as well as age, sex, and condition of fish). Thermally-related fish kills would not be likely under the cooling tower alternatives, because their predicted discharge temperatures would fall within the range of those tolerated, if not preferred, by resident fish species.

*Chemical Effects.* Under the Once-Through Cooling alternative, 125,000 gallons per minute of effluent from the APT facility would discharge to Par Pond through the pre-cooler ponds. Under the two cooling tower alternatives, 2,000 gallons per minute of blowdown would discharge continuously either to Par Pond (through the pre-cooler ponds) or Pen

Branch (through Indian Grave Branch). These discharges would contain small amounts of chlorides, or salts.

The Environmental Protection Agency periodically publishes ambient water quality criteria (AWQC), concentrations or levels of substances that are known to affect "diversity, productivity, and stability" of aquatic communities, including "plankton, fish, shellfish, and wildlife" (EPA 1986). The purpose of these criteria is to assist state regulatory agencies in the development of location-specific standards to protect aquatic life. The acute and chronic AWQC for chloride are 860 and 230 milligrams per liter, respectively (EPA 1991). The maximum predicted (instantaneous) concentrations of chlorides in once-through cooling water and cooling tower blowdown would be 13 and 39 milligrams per liter, respectively. Both of these values are an order of magnitude lower than the acute and chronic AWQC for chloride. The highest average concentrations of chloride in once-through cooling water and cooling tower blowdown would be 9 and 27 milligrams per liter, respectively. In addition, chlorides in cooling water would be diluted on discharge to the Par Pond system or Pen Branch. Therefore, there would be no impacts to aquatic biota in Par Pond and Pen Branch from chlorides in once-through cooling water or cooling tower discharges.

APT cooling water discharge would also contain dissolved and suspended solids. Fish and other aquatic life must tolerate a range of dissolved solids concentrations to survive under natural conditions. A study of fish in Canadian lakes concluded that waters with dissolved solids greater than 15,000 milligrams per liter were un-

suitable for most freshwater species (EPA 1986). The maximum predicted dissolved solids concentration in once-through cooling water would be 91 milligrams per liter in May (see Table 4-5). The maximum predicted dissolved solids concentration in cooling tower blowdown would be 273 milligrams per liter, also in May. These concentrations would also be diluted on discharge to Par Pond or Pen Branch. Therefore, the possibility of adverse effects on aquatic organisms in Par Pond or Pen Branch from dissolved solids in APT discharge water is remote.

Excess suspended solids may result in adverse effects on fish and fish forage populations. The four primary effects are (EPA 1986):

- Direct effects on fish in the water column (e.g., reduced resistance to disease)
- Inhibited development of fish eggs and larvae
- Interference with natural movements and migration
- Reduction in the abundance of fish forage

In addition, suspended materials can settle and blanket the bottom of water bodies, resulting in effects to benthic species, blocking of gravel spawning beds, and removal of dissolved oxygen from the overlying water. No ambient water quality standards are available for suspended solids. EPA (1986) suggests that "Settleable and suspended solids should not reduce the depth of the compensation point for photosynthetic activity by more than 10 percent from the seasonally established norm for aquatic life." The National Academy of Sciences (see American Fisheries Society 1979) recommended the following "settleable/suspended" solids criteria (maximum concentrations) for the protection of aquatic organisms:

- High level of protection      25 milligrams per liter

- Moderate protection      80 milligrams per liter
- Low level of protection      400 milligrams per liter

Total suspended solids in once-through cooling water would range from 3 to 18 milligrams per liter (instantaneous maximum), while total suspended solids in cooling tower blowdown would range from about 9 to 54 milligrams per liter. These relatively low concentrations of solids in once-through cooling water and cooling tower blowdown would be further diluted on discharge to Par Pond or Pen Branch. Based on the National Academy of Sciences recommendations, the levels of suspended solids expected under the various cooling water alternatives would pose little or no threat to aquatic life in the Par Pond or Pen Branch systems.

DOE would use a number of proprietary chemicals in the tertiary cooling water system and cooling towers to control scale, corrosion, algae, and microbial organisms. These chemicals would control corrosion or buildup of algae or microbial organisms. Application and dosage rates would be recommended by the manufacturer. Blowdown from the cooling towers, normally 2,000 gallons per minute, would be reduced during treatment cycles to prevent the release of potentially toxic chemicals to the environment. Once chemicals have been neutralized or degraded to safe levels (based on testing or monitoring), the normal blowdown would resume.

#### 4.2.2.3 Wetland Ecology

**Construction.** DOE has identified wetlands near the proposed APT sites and does not expect any impacts to wetlands as a result of construction activities. Both the preferred and alternate sites are upland locations with no wetlands (including Carolina bays) within their boundaries. The locations of pipelines, trans-

mission lines, roads, and railway lines to support the APT facilities would be chosen so as to minimize potential impacts to any wetlands near the routing corridors. In addition, DOE would protect adjacent or downgradient wetlands from construction impacts by implementing Best Management Practices to prevent the offsite movement of soil or sedimentation of water bodies, as discussed in Section 4.1.1.

**Operations.** DOE has identified two potential sources of impacts on wetlands from operation of the APT facilities:

- Discharging heated water from the accelerator cooling system to onsite surface water bodies such that the increased temperatures affect wetlands vegetation and wildlife
- Discharging large volumes of water from the cooling system, thereby changing the flow and water levels in surface water bodies and affecting wetlands vegetation and wildlife

Heated blowdown from cooling tower operations would be marginally higher than the ambient maximum temperature. During cooler months, the warmth provided by the cooling water blowdown could have positive impacts, including the lengthening of the growing season for floating-leaved and emergent vegetation, amphibians, and reptiles. Under the Once-Through Cooling Water alternative, DOE expects the loss of some less hardy wetland vegetation.

All alternatives for APT operation would cause impacts to wetlands because of cooling water discharges. The discharge of the K-Area Cooling Tower alternative could be as high as 89°F at a flow rate of about 2,000 gallons per minute into Indian Grave Branch, which flows into Pen Branch. Recent measurements in the Pen Branch system indicate an annual average temperature of 72°F (Wike et al. 1994); in 1995 the seasonal maximum temperature for Pen Branch in its lower reaches was 85°F. Thus the maximum blowdown temperature would be only marginally higher than the ambient maximum

temperature, and the temperature increase caused by the cooling water discharge would have negligible negative impacts on wetlands vegetation and wildlife. During cooler months, the warmth provided by the cooling water blowdown could have positive impacts, including a slight lengthening of the growing season for the floating-leaved and emergent vegetation, amphibians, and reptiles inhabiting the stream and its delta in the Savannah River Swamp (Grace and Tilly 1976; Wilde and Tilly 1985; Brisbin 1997).

Alternatives that used mechanical-draft cooling towers would discharge blowdown to Pond 2, and in turn to Pond 5, Pond C, and Par Pond in sequence. As indicated in Table 4-3, the maximum annual discharge temperature would be 88°F at a flow rate of about 2,000 gallons per minute, depending on the alternative. The maximum ambient temperature in the canal between P-Area and Pond 2 was 81°F from October 1994 through September 1996 (Cooney et al. 1996). Thus the temperature increase caused by the cooling water discharge would have a negligible negative impact on wetlands vegetation and wildlife. The warmth provided by the cooling water blowdown during cooler months could provide positive impacts, including a lengthening of the growing season for the floating-leaved and emergent vegetation, amphibians, and reptiles inhabiting the canals and ponds (Grace and Tilly 1976; Wilde and Tilly 1985; Brisbin 1997).

The Once-Through Using River Water alternative would discharge water to the Par Pond system (through Ponds 2, 5, C, and Par Pond) with a maximum temperature during warmer months of about 102°F (Table 4-4). Most actively growing plants cannot survive for long periods at temperatures above about 104°F (Wike et al. 1994). Although the cooling water discharge would be slightly less than this threshold, DOE expects the loss of some less hardy wetlands vegetation, with greater impacts in Ponds 2 and 5, as compared to Pond C and Par Pond. Heated effluent from the APT under the Once-Through Cooling alternative could affect aquatic and semi-aquatic animals in down-

stream wetlands. Amphibians, reptiles, and semi-aquatic mammals (e.g., muskrats and beavers, if present) in the pre-cooler pond wetlands would be most affected. Amphibians and reptiles, which like fish are unable to regulate their body temperatures internally, are particularly sensitive to changes in the thermal environment. These animals regulate their body temperatures by selecting habitats in which temperatures are suitable (e.g., a warmer or cooler part of a pond) or by controlling exposure to the sun's radiation (seeking out shady or sunlit areas). As a general rule, mammals are less affected by heated discharges from industrial facilities, because they are larger and more mobile. As a result, they are able to move longer distances in response to thermal perturbations, and are better equipped to seek out more favorable habitats.

The effects of thermal effluents on amphibians and reptiles, which can range from elimination of more sensitive species to subtle changes in community structure, were intensively studied at the Savannah River Site during the years in which production reactors operated (Gibbons and Sharitz 1974; Nelson 1974). For example researchers at the SRS found that larval frogs and toads in a reservoir (Pond C) receiving heated effluent from a production reactor developed more rapidly and metamorphosed sooner than those in unheated areas and had a longer-than-normal breeding seasons. As a result, frogs and toads were smaller than normal as juveniles and adults, and were present as young later in the season than normal. As a result, they were more vulnerable to terrestrial predators, susceptible to seasonally-related food shortages, and exposed to adverse weather conditions. Turtles (yellow-bellied sliders), on the other hand, grew more rapidly, grew to larger sizes, achieved sexual maturity sooner, and had larger clutch sizes in areas receiving heated effluent (Christy et al. 1974; Gibbons and Sharitz 1974). Thus, reproductive potential was enhanced as a indirect result of thermal alteration.

In the area of Par Pond surrounding the discharge point, the warmth provided by the

heated effluent during cooler months could provide positive impacts, including a lengthening of the growing season for the floating-leaved and emergent vegetation, as well as amphibians, and reptiles (Grace and Tilly; Wilde and Tilly 1985; Brisbin 1997).

As discussed in Section 3.2.2, the natural flow of Indian Grave Branch is about 10 cubic feet per second. The increase in flow due to discharges from the K-Area Cooling Tower alternative (about 2,000 gallons per minute, depending on the selected alternative) would raise the water level in the upper reaches of the stream (an estimated 0.5 to 0.75 feet) and cause a loss of wetlands vegetation and changes in species composition in the stream corridor and delta (Nelson 1997). Species less tolerant of flooding that have become established since the cessation of discharges from K-Reactor would be replaced by flood-tolerant vegetation. The ongoing forest wetland restoration activities in Pen Branch, which are a part of the mitigation mandated in the Record of Decision for the *Final Environmental Impact Statement, Continued Operation of K-, L-, and P-Reactors, Savannah River Site, Aiken, South Carolina* (DOE 1990) could be adversely affected. Less flood-tolerant hardwoods planted in the upper reaches of the Pen Branch corridor could be lost (Nelson 1997).

Section 4.1.2 contains flow rates for the P-Area canal for March through September 1996. Additions of about 2,000 gallons per minute of blowdown under the Mechanical-Draft Cooling Tower alternative would increase the mean flow coming into Pond 2 32-fold. Additions of 125,000 gallons per minute of effluent under the Once-Through Cooling alternative would increase the mean flow through the system by a factor of 280 and could raise water levels in Ponds 2 and 5 by 1.5 feet (Pinder 1997). Impacts to wetlands vegetation would be very small under the Mechanical-Draft Cooling Tower alternative. However, the Once-Through Cooling alternative would raise water levels significantly, causing vegetation to move along the hydrologic gradient in the littoral zone around the ponds. Some vegetation would be lost, but it would become reestablished along

the new shore line as water levels stabilized at full pool.

Hydrologic modeling predicts that water levels in Par Pond would rise between 0.1 and 0.6 foot, maintaining the 200-foot elevation (full pool) between 5 and 8 months a year under the Mechanical-Draft Cooling Tower alternative. Under the Once-Through Cooling alternative, full pool would be maintained all year (DiFiore-Smith 1997a). Impacts to wetlands vegetation in Par Pond would be minimal under both Mechanical-Draft Cooling Tower and Once-Through Cooling alternatives. The discharges to the system would act to stabilize water levels and so encourage the development of stable communities of wetlands vegetation around the lake. The stable water levels could result in stagnant sediments in some of the back regions of Par Pond coves, producing areas devoid of vegetation (DOE 1997a).

Hydrologic modeling predicts that water levels in Lower Three Runs would not be substantially raised under either the Mechanical-Draft Cooling Tower or the Once-Through Cooling alternatives. The mean flow in Lower Three Runs at Road B during water years 1974 through 1992 was 37 cubic feet per second with the highest and lowest daily mean discharges for the period at 220 and 0.6 cubic feet per second (Bennett et al 1992), respectively. This translates to an estimated average depth of flow of 1.3 feet at a velocity of 0.83 foot per second. Assuming that all flow in Lower Three Runs at Road B is from Par Pond, discharge of about 2,000 gallons per minute under the Mechanical-Draft Cooling Tower alternative would result in an average discharge of 0.8 cubic feet per second in Lower Three Runs. Average annual flows ranged from 0.4 to 9.5 cubic feet per second. The estimated average depth of flow in the stream at Road B would be 1.31 feet at a velocity of 0.84 foot per second. Under the Once-Through Cooling alternative, an increase of 125,000 gallons per minute would result in an average discharge of 11.6 cubic feet per second in Lower Three Runs with the average annual flow ranging from 9.3 to 40.4 cubic feet per second. The estimated average depth of flow in the stream would be

1.5 feet at a velocity of 0.9 foot per second (DiFiore-Smith 1997b).

#### 4.2.2.4 Threatened or Endangered Species

**Construction.** DOE has not identified any populations of threatened or endangered plant or animal species on the preferred or alternate site or in the likely corridors for related transmission lines, pipelines, and roads. DOE will continue to review these locations during the design and construction of the infrastructure for the APT to ensure there would be no adverse impacts to threatened or endangered species.

**Operation.** Actions related to cooling water withdrawal and discharge would be those most likely to affect threatened or endangered species, especially:

- The shortnose sturgeon
- The American alligator
- The bald eagle

No threatened or endangered species occur within either APT site. Par Pond and the pre-cooler ponds, however, are used by American alligators and bald eagles. The alligators do not breed in Ponds 2 and 5 and would abandon the ponds if water temperature exceeded their tolerance range. In Par Pond and Pen Branch, potential effects on alligators could be positive in that the warmer waters could lengthen the active period for the reptiles. Bald eagles use the Par Pond system for feeding. Potential fish kills associated with Once-Through Cooling Water alternative could provide the eagles with an additional food source.

DOE evaluated impingement and entrainment of shortnose sturgeon during withdrawals of large volumes of cooling water from the Savannah River and concluded that these operations would not affect the continued existence of this species in the Savannah River (Muska and Matthews 1983; DOE 1990). DOE based this conclusion in part on the facts that entrainment was unlikely because shortnose sturgeon eggs are demersal (sinking), adhesive, and negatively

buoyant and that impingement of healthy juvenile and adult shortnose sturgeon on cooling water system screening devices is highly unlikely given their strong swimming ability. Therefore, DOE does not expect any impact on this species from APT operations, which would require much smaller volumes of cooling water.

The American alligator population of the Par Pond system, including Ponds 2, 5, and C, would be relatively unaffected by the discharges of heated effluent associated with the Once-Through Cooling alternative. The species has relatively broad temperature tolerances, with a critical thermal maximum of 100°F (Wike et al. 1994). Discharges into the Par Pond system from the APT facility would at times during the summer season exceed this temperature slightly and could cause the alligators in Ponds 2 and 5 to abandon the ponds. These ponds do not have breeding populations, and alligator use of the ponds is intermittent and transitory (Brisbin 1997). However, displacement could result in increased incidence of intraspecific encounters as alligators from Ponds 2 and 5 are forced into established territories of adults in other areas. There could be an increased likelihood of fatal encounters with humans and automobiles as well. Discharges associated with the other cooling water alternatives could have a positive impact on the alligator populations in the Par Pond system or the Indian Grave/Pen Branch system by lengthening the active period of the reptiles.

Bald eagles use the Par Pond system for feeding. Operation of the APT facilities and discharge of cooling water under the Once-Through Cooling Water alternative could result in fish kills in Ponds 2 and 5. Eagles would be able to forage on the dead fish as a food source, as they have in the past (Wike et al. 1994). Any reductions in overall fish stocks in Ponds 2 and 5 would have little if any impact on eagle use of the Par Pond system. The other alternatives would have no negative impacts to the eagles.

### 4.3 Socioeconomics

Economic and demographic forecasting models such as the REMI model are used to project through simulations the effects of changes of local economic variables (e.g., number of jobs in a particular industry, wage rates, or increases in capital investment) on other economic measures such as total employment, population, or total personal income. In this EIS, multiple simulations, one for each alternative which identifies a different level of APT employment, were run with the REMI model. The results of these simulations are tabulated and compared to show the different economic effects of each of the EIS alternatives. The REMI model holds all other regional inputs constant, which allows the analysis to isolate and distinguish the impacts of changes between alternative economic scenarios.

The potential socioeconomic impacts associated with APT are relatively small in comparison with historical trends and are not expected to stress existing regional infrastructure or result in a "boom" situation.

Data for the APT action alternatives are derived from the APT Conceptual Design Report.

The following scenarios are analyzed.

- Construction and operation of the Preferred alternative
- Construction and operation of the APT with the following technologies:
  - Lithium-6 feedstock material
  - Room temperature operation
  - Use of K-Area cooling tower; once-through cooling water; mechanical-draft

cooling towers with groundwater makeup

- Construction and operation of a new generating station for electricity

**4.3.1 PREFERRED ALTERNATIVE**

**4.3.1.1 Construction**

*Economic and Population Changes.* An analysis of the APT Conceptual Design Report provided information on the size and schedule of the expected work force to construct and operate the APT facilities. These data were reviewed and the work force was assigned by their expected Standard Industrial Code (SIC) classification according to that annual schedule. These work force data were entered into the REMI model as increases from the No Action alternative. There is no distinction made in any of the analyses for the two different sites. Construction and operation at either site are assumed to be the same, except that the length of pipe for the hookup to existing river water supply and blow down lines will vary. Because this variance would be only approximately 2 to 3 employees for 1 year (WSRC 1996b), the difference in the regional economic impacts of constructing at one site as opposed to the other would be negligible.

The cooling water option under the Preferred alternative is mechanical-draft cooling tower with river water makeup. Because the work

force for another cooling option, mechanical-draft cooling tower with groundwater makeup, would not be appreciably different, the difference in the regional economic impacts of constructing either of these options would be negligible.

Table 4-29 lists the APT Preferred alternative construction, startup, and operating work force by SIC category.

In the short term, there would be a construction work force at the SRS of up to 1,000 in the sixth year of the analysis, with a total peak employment in year five of approximately 1,400, including all APT employees at SRS. Regionally, employment under the Preferred alternative would exceed employment under the No Action alternative by 2,300 in the sixth year. The gap between these two scenarios would narrow to approximately 700 seven years later as the construction and startup work forces phased out. Under the Preferred alternative, population changes (which lag employment) would exceed the population under the No Action alternative by almost 3,200 in year nine of the analysis. Figures 4-2 and 4-3 show the employment and population differences between the No Action alternative and the other APT configuration alternatives. Because there would be no meaningful long-term difference in any of the measures between APT alternatives, the figures in this section show only the first 15 years of construction, startup, and operations.

**Table 4-29. Preferred alternative work force.**

SIC Category	Year										
	1	2	3	4	5	6	7	8	9	10	11
Professional	38	208	402	430	270	182	147	96	68	6	4
Chemical	7	37	72	107	175	198	250	304	486	516	516
Construction	7	138	464	710	958	993	916	530	251	7	4
<b>Total</b>	<b>52</b>	<b>383</b>	<b>939</b>	<b>1,247</b>	<b>1,404</b>	<b>1,373</b>	<b>1,312</b>	<b>930</b>	<b>804</b>	<b>529</b>	<b>525</b>

Total (Chemical)	Year										
	12	13	14	15	16	17	18	19	20	21	After
<b>Total (Chemical)</b>	<b>482</b>	<b>472</b>	<b>463</b>	<b>453</b>	<b>445</b>	<b>439</b>	<b>434</b>	<b>428</b>	<b>423</b>	<b>418</b>	<b>418</b>

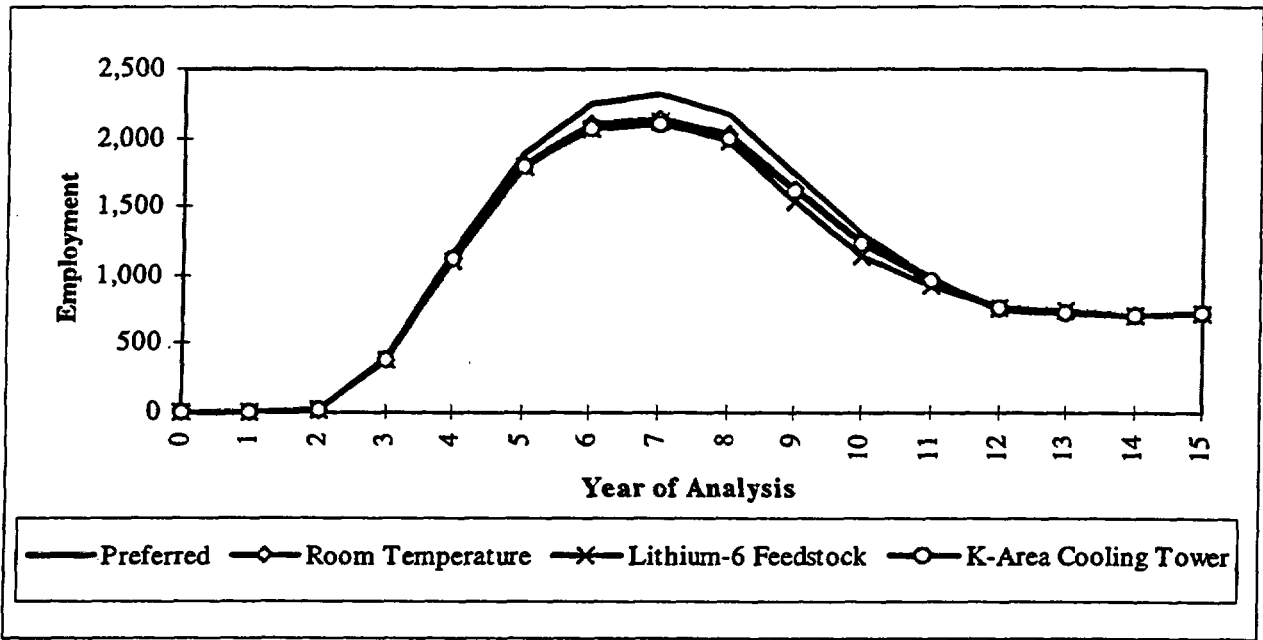

Figure 4-2 Regional employment differences greater than No Action alternative.

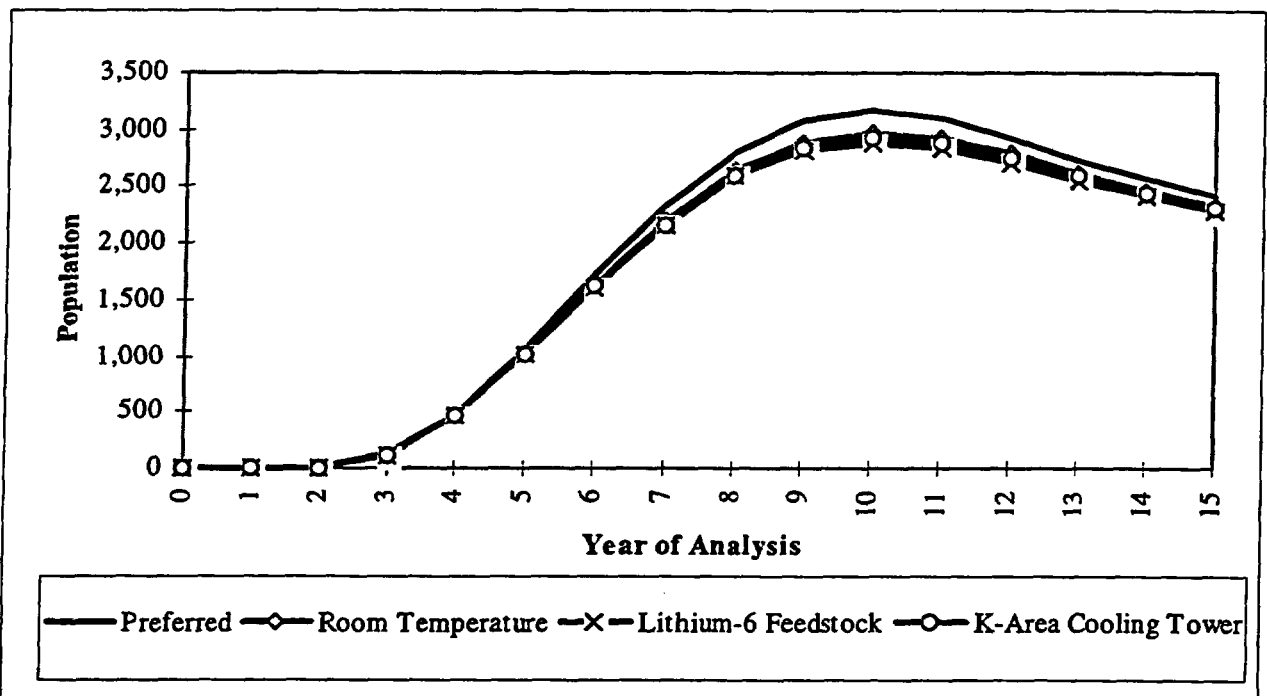

Figure 4-3. Regional population differences greater than No Action alternative.



Personal income and GRP would show increases over the No Action alternative during the construction build up. These increases of personal income and GRP peak at \$77 and \$120 million in the sixth year, respectively. Figures 4-4 and 4-5 show the projected total personal income and GRP differences between the No Action alternative and the other APT alternatives.

Regional expenditures by state and local governments under the Preferred alternative would be approximately \$11 million higher than under the No Action alternative by year nine of the analysis. Figure 4-6 shows projected state and local government expenditure differences between the No Action alternative and the other APT alternatives.

The increased work force employed under the Preferred alternative will stimulate regional economic growth which is greater than the economic growth described in Section 3.5.3 for the No Action alternative. However, the average annual rates of growth for all of the analyzed regional economic measures during the construction period are less than the regional rates of growth during the 4-year period prior to the period of analysis and the measures do not show an economic boom and rapid population growth which could strain the local infrastructure and services. These annual rates are shown in Table 4-30. Instead, these economic measures show an economy which on the whole is growing slowly during the construction period. Because infrastructure and government services have historically expanded to meet population and economic growth in excess of rates projected during the construction phase, there is no reason to believe that construction of the APT Preferred alternative will adversely strain the regional infrastructure.

#### 4.3.1.2 Operations

In the long run, as the construction and project management professionals complete their work and are replaced by the operations staff of 342 and 153 support employees, a total of 495, the differences between the Preferred alternative

and No Action alternatives become relatively constant for employment and population. After operations begin, the analysis reflects the Conceptual Design Report assumption that there would be increased efficiencies in operations with consequent reductions in staff. Ten years after startup, the operations staff would be reduced from 342 to 265, and total staff to 418, and would remain constant thereafter. Regional employment under the Preferred alternative would be greater by approximately 885 than under the No Action alternative. Similarly, regional population would be greater under the Preferred alternative by approximately 1,750. The gaps between the Preferred and No Action alternatives for employment and population would gradually increase at the end of the analysis period. During the operations phase, total personal income and total GRP would be approximately \$46 million and \$110 million higher, respectively, for the Preferred alternative. State and local government expenditures would be approximately \$7 million higher under the Preferred alternative.

During the operations phase, the analysis shows growth of the regional economic measures would return to rates consistent with the national economy, and within historic rates of growth for the region. Thus, the Preferred alternative would cause no long-term significant impacts.

Regional economic growth under the preferred APT alternative would be greater than under the No Action alternative. However, temporary increases in construction employment and long-term operation of the accelerator would not cause a boom and would have negligible impacts.

### 4.3.2 APT WITH SUPERCONDUCTING ALTERNATIVE

#### 4.3.2.1 Construction

Table 4-31 shows the consolidated construction, startup, and operating work force for each of the alternatives and options for APT. Dif-

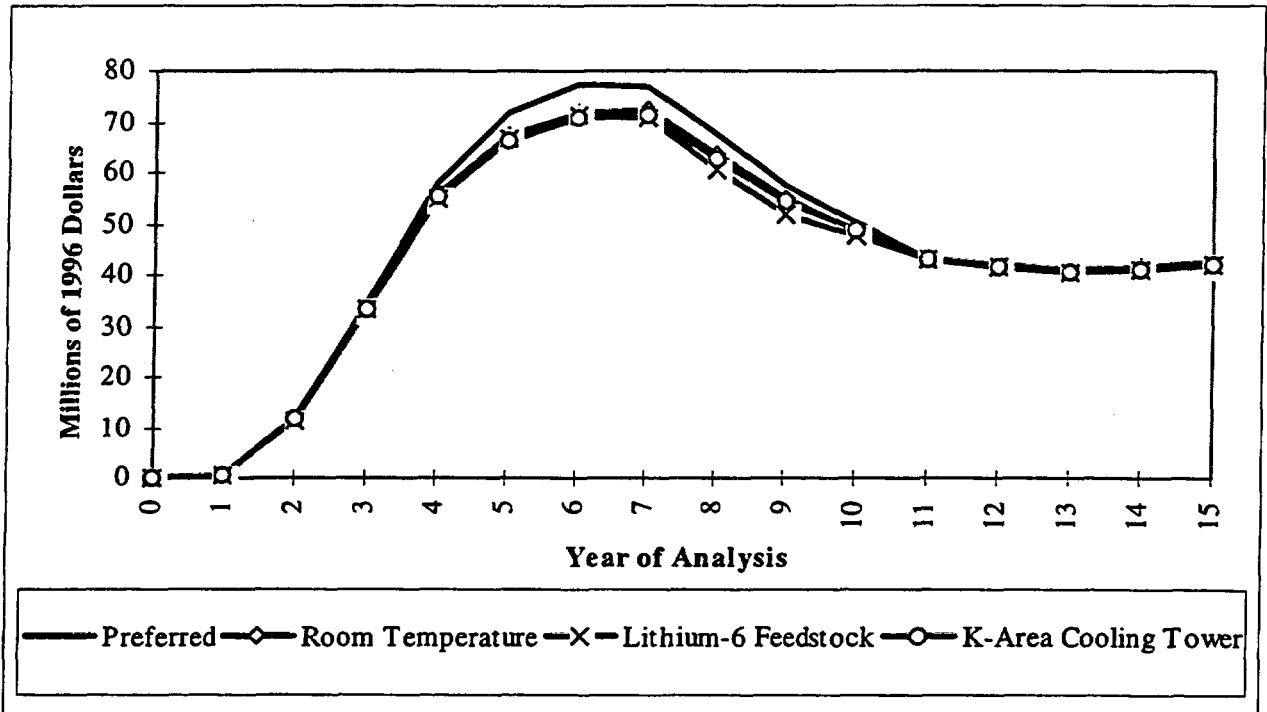

Figure 4-4. Regional total personal income differences greater than No Action alternative.

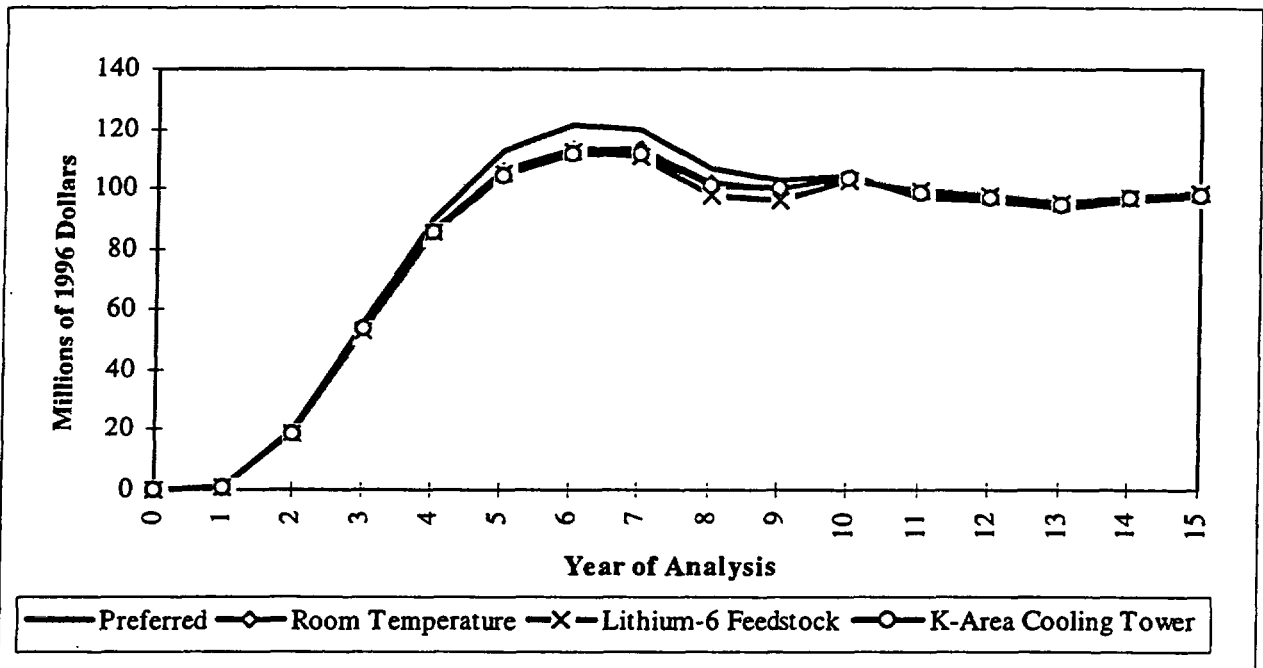

Figure 4-5. Gross regional product differences greater than No Action alternative.

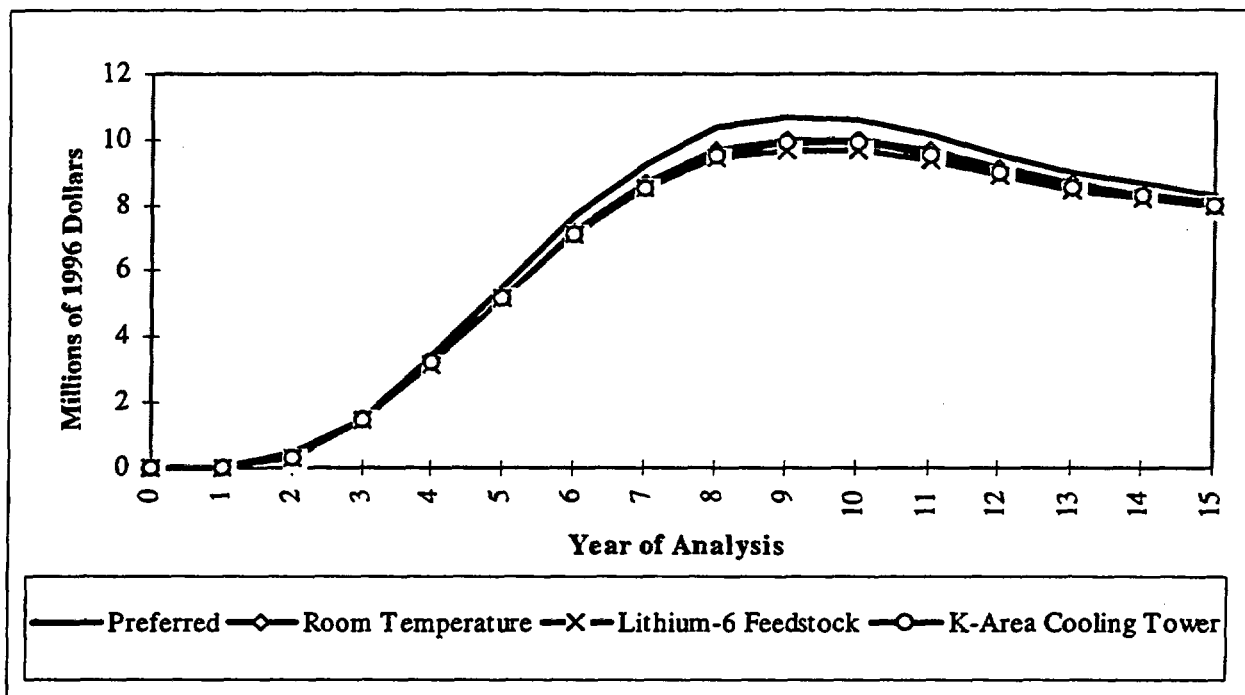

Figure 4-6. State and local government expenditures differences greater than No Action alternative.

Table 4-30. Rates of growth for economic measures.<sup>a</sup>

	Preferred alternative <sup>b</sup> (percent)	4-year historical period (percent)
Employment	0.4	1.2
Population	0.6	1.0
Total personal income	1.6	5.1
Gross regional product	1.1	2.1
State/local government expenditures	1.9	2.4

a. Source: REMI (1996).  
 b. Average annual rates for construction period.

ferences in the SRS work force attributable to APT alternative options would be primarily in the construction industry.

Under the Room Temperature alternative, the construction and associated professional work force would be less during the construction phase than under the Preferred alternative. However, the increased workforce would be approximately 120 fewer employees than for the Preferred alternative in year five of the analysis. Changes in regional employment and popula-

tion would be approximately 200 less than under the Preferred alternative. This small short-term regional decrease from the Preferred alternative would not have any meaningfully different effect on the regional economy or socioeconomic infrastructure than was discussed under the Preferred alternative. There is no appreciable difference in total personal income, GRP, or State and local expenditures between these two alternatives. See Section 4.3.1.1.

**Table 4-31. Workforce by alternative.<sup>a</sup>**

Alternative	Year										
	1	2	3	4	5	6	7	8	9	10	11
Preferred alternative	52	383	939	1,247	1,404	1,373	1,312	930	804	529	525
Room temperature	49	369	912	1,190	1,283	1,280	1,222	875	767	529	525
Lithium-6 Feedstock	49	365	898	1,171	1,266	1,267	1,173	807	719	529	525
K-Area Cooling Tower	49	369	908	1,171	1,262	1,259	1,204	865	759	529	525
Coal-fired power <sup>b</sup>	49	369	974	1,599	2,380	2,282	1,545	1,059	951	713	709
Gas-fired power <sup>b</sup>	49	369	912	1,322	1,591	1,561	1,342	985	877	639	635

Alternative	Year										
	12	13	14	15	16	17	18	19	20	21	After
Preferred alternative	482	472	463	453	445	439	434	428	423	418	418
Room temperature	482	472	463	453	445	439	434	428	423	418	418
Lithium-6 Feedstock	482	472	463	453	445	439	434	428	423	418	418
K-Area Cooling Tower	482	472	463	453	445	439	434	428	423	418	418
Coal-fired power <sup>b</sup>	666	656	647	637	629	623	618	612	607	602	602
Gas-fired power <sup>b</sup>	592	582	573	563	555	549	544	538	533	528	528

a. Source: LANL (1997).

b. Includes Preferred alternative plus power plant labor.

#### 4.3.2.2 Operations

In the longer term the differences between the room temperature and Preferred alternative would not be meaningful in any of the measures.

The regional socioeconomic impacts under the room temperature alternative would be the same as for the Preferred alternative. See Section 4.3.1.2.

#### 4.3.3 APT WITH LITHIUM-6 FEEDSTOCK

##### 4.3.3.1 Construction

Under this alternative, the APT construction and associated professional work force would

be approximately 140 less than that for the Preferred alternative in year 5, with a smaller or nonexistent difference in other years. Under the Lithium-6 Feedstock Material alternative, annual regional employment and population would be less than that under the Preferred alternative by approximately 200 and 250, respectively, in the short term. Total personal income and GRP would be approximately \$7 and \$9 million less than under the Preferred alternative. There would be no appreciable difference in state and local expenditures between either the Lithium-6 Feedstock Material or Preferred alternative during the construction phase.

The regional socioeconomic impacts under the Lithium-6 Feedstock Material alternative would be the same as those for the Preferred alternative. See Section 4.3.1.1.

#### **4.3.3.2 Operations**

During the operations phase, there would be no appreciable differences in any of the regional measures between this alternative and the Preferred alternative. The regional impacts under this alternative are the same as for the Preferred alternative. See Section 4.3.1.2.

#### **4.3.4 APT WITH K-AREA COOLING TOWER AND APT WITH ONCE-THROUGH COOLING**

##### **4.3.4.1 Construction**

Under the K-Area Cooling Tower alternative, the APT construction and associated professional work force would be approximately 40 less than for the Preferred alternative in year 5, with smaller or nonexistent differences in other years. A fourth (and last) cooling option is once-through with river water make-up. The workforce for this option is estimated to be close to the workforce for the K-Reactor cooling water tower. As such, there would not be appreciable differences in the regional economic impacts of these two cooling options and there is no distinction made in the analysis between them.

Under the K-Area Cooling Tower alternative, annual regional employment and population would be approximately 210 and 230 less than under the Preferred alternative.

Total personal income and GRP would be approximately \$7 and \$9 million less than under the Preferred alternative. There would be no appreciable difference in state and local expenditures between the K-Area Cooling Tower alternative and the Preferred alternative. The short-term regional socioeconomic impacts of construction would be the same as those for the Preferred alternative. See Section 4.3.1.1.

##### **4.3.3.2 Operations**

In the longer term, there would be no appreciable difference in employment or population between this alternative and the Preferred alter-

native. There would be no appreciable difference in total personal income, GRP, or State and local expenditures between either the K-Area Cooling Tower or Preferred alternative in either the long or short term.

The regional socioeconomic impacts under the K-Area Cooling Tower alternative would be the same as those for the Preferred alternative. See Section 4.3.1.2.

#### **4.3.5 ENVIRONMENTAL JUSTICE**

This EIS examines whether minorities or low-income communities (as defined in Section 3.5.2) could receive disproportionately high and adverse human health and environmental impacts. Even though DOE expects little or no adverse health impacts from any of the alternatives, it analyzed whether there would be "disproportionately high and adverse human health or environmental effects (of these alternatives) on minority populations or low-income populations" (Executive Order 12898). Figures 3-17 and 3-18 show minorities or low-income communities, respectively, by census tract. This section discusses predicted average radiation doses received by individuals in those communities and compares them to the predicted per capita doses that other communities in the 50-mile region could receive. It also discusses impacts of doses that downstream communities could receive from liquid effluents from all alternatives, and potential impacts from nonradiological pollutants

Figure 4-7 shows a wheel with 22.5-degree sectors and concentric rings from 10 to 50 miles at 10-mile intervals. DOE calculated a fraction of the total population dose for each sector (Table 4-32), laid the sector wheel over the census tract map, and assigned each tract to a sector. If a tract fell in more than one sector, the analysis assigned it to the sector with the largest value.

DOE analyzed the impacts by comparing the per capita dose received by each type of community to the other types of communities in a defined region. To eliminate the possibility that

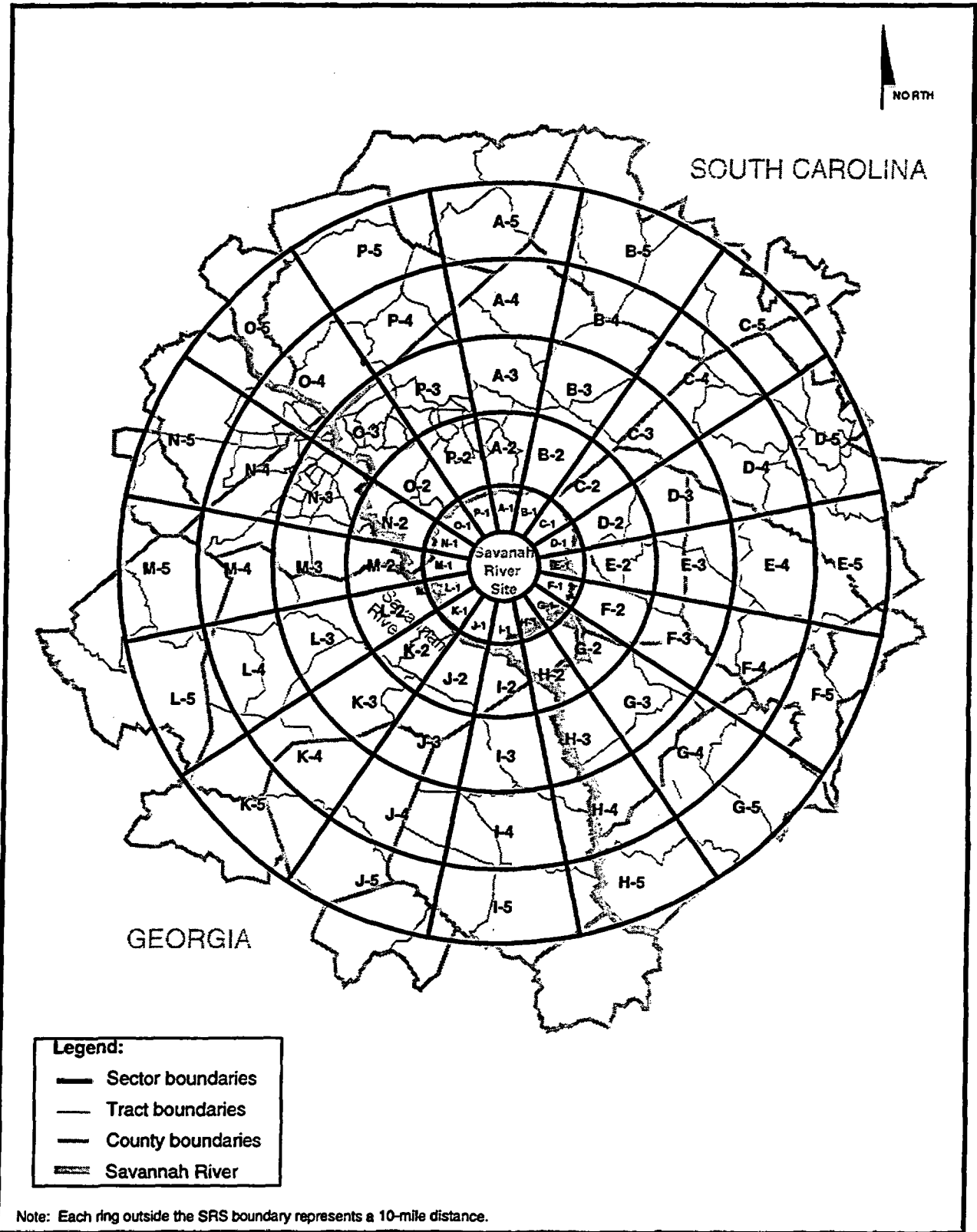

Figure 4-7. Annular sectors around the Savannah River Site.

PK68-Z1-PC

Table 4-32. Annular sector factors for local dose evaluations.

Sector <sup>a</sup>	Fraction of total population dose in sector					Fraction of total population dose received by average person in sector				
	1	2	3	4	5	1	2	3	4	5
	(5-10 mi)	(10-20 mi)	(20-30 mi)	(30-40 mi)	(40-50 mi)	(5-10 mi)	(10-20 mi)	(20-30 mi)	(30-40 mi)	(40-50 mi)
A (N)	3.1×10 <sup>-4</sup>	2.8×10 <sup>-2</sup>	2.7×10 <sup>-2</sup>	8.6×10 <sup>-3</sup>	1.5×10 <sup>-2</sup>	1.2×10 <sup>-5</sup>	5.2×10 <sup>-6</sup>	2.7×10 <sup>-6</sup>	1.7×10 <sup>-6</sup>	1.2×10 <sup>-6</sup>
B (NNE)	5.9×10 <sup>-5</sup>	5.8×10 <sup>-3</sup>	4.7×10 <sup>-3</sup>	6.5×10 <sup>-3</sup>	1.5×10 <sup>-2</sup>	9.8×10 <sup>-6</sup>	4.4×10 <sup>-6</sup>	2.3×10 <sup>-6</sup>	1.5×10 <sup>-6</sup>	1.0×10 <sup>-6</sup>
C (NE)	1.0×10 <sup>-5</sup>	1.4×10 <sup>-2</sup>	7.0×10 <sup>-3</sup>	8.3×10 <sup>-3</sup>	1.18×10 <sup>-2</sup>	1.0×10 <sup>-5</sup>	4.6×10 <sup>-6</sup>	2.4×10 <sup>-6</sup>	1.6×10 <sup>-6</sup>	1.2×10 <sup>-6</sup>
D (ENE)	2.8×10 <sup>-4</sup>	1.3×10 <sup>-2</sup>	9.6×10 <sup>-3</sup>	7.4×10 <sup>-3</sup>	4.2×10 <sup>-2</sup>	1.0×10 <sup>-5</sup>	4.1×10 <sup>-6</sup>	2.1×10 <sup>-6</sup>	1.4×10 <sup>-6</sup>	1.0×10 <sup>-6</sup>
E (E)	1.3×10 <sup>-3</sup>	2.2×10 <sup>-2</sup>	8.9×10 <sup>-3</sup>	9.7×10 <sup>-3</sup>	3.5×10 <sup>-3</sup>	8.3×10 <sup>-6</sup>	3.3×10 <sup>-6</sup>	1.7×10 <sup>-6</sup>	1.1×10 <sup>-6</sup>	8.0×10 <sup>-7</sup>
F (ESE)	2.6×10 <sup>-4</sup>	4.4×10 <sup>-3</sup>	2.8×10 <sup>-3</sup>	2.6×10 <sup>-3</sup>	2.2×10 <sup>-3</sup>	7.1×10 <sup>-6</sup>	2.8×10 <sup>-6</sup>	1.5×10 <sup>-6</sup>	9.4×10 <sup>-7</sup>	6.9×10 <sup>-7</sup>
G (SE)	1.3×10 <sup>-4</sup>	1.1×10 <sup>-3</sup>	6.8×10 <sup>-3</sup>	4.5×10 <sup>-3</sup>	4.3×10 <sup>-3</sup>	5.0×10 <sup>-6</sup>	2.0×10 <sup>-6</sup>	1.0×10 <sup>-6</sup>	6.8×10 <sup>-7</sup>	5.0×10 <sup>-7</sup>
H (SSE)	1.6×10 <sup>-4</sup>	6.6×10 <sup>-4</sup>	6.9×10 <sup>-4</sup>	8.1×10 <sup>-4</sup>	1.1×10 <sup>-3</sup>	4.2×10 <sup>-6</sup>	1.7×10 <sup>-6</sup>	9.0×10 <sup>-7</sup>	6.0×10 <sup>-7</sup>	4.4×10 <sup>-7</sup>
I (S)	2.2×10 <sup>-6</sup>	5.5×10 <sup>-4</sup>	7.2×10 <sup>-4</sup>	2.7×10 <sup>-3</sup>	9.3×10 <sup>-4</sup>	2.2×10 <sup>-6</sup>	9.8×10 <sup>-7</sup>	5.4×10 <sup>-7</sup>	3.7×10 <sup>-7</sup>	2.8×10 <sup>-7</sup>
J (SSW)	1.3×10 <sup>-5</sup>	2.4×10 <sup>-3</sup>	2.9×10 <sup>-3</sup>	4.1×10 <sup>-3</sup>	2.1×10 <sup>-3</sup>	6.5×10 <sup>-6</sup>	2.7×10 <sup>-6</sup>	1.4×10 <sup>-6</sup>	9.8×10 <sup>-7</sup>	7.2×10 <sup>-7</sup>
K (SW)	1.9×10 <sup>-4</sup>	4.2×10 <sup>-3</sup>	5.2×10 <sup>-3</sup>	4.1×10 <sup>-3</sup>	3.0×10 <sup>-3</sup>	1.1×10 <sup>-5</sup>	4.4×10 <sup>-6</sup>	2.3×10 <sup>-6</sup>	1.6×10 <sup>-6</sup>	1.1×10 <sup>-6</sup>
L (WSW)	5.2×10 <sup>-4</sup>	3.9×10 <sup>-3</sup>	1.3×10 <sup>-2</sup>	2.8×10 <sup>-3</sup>	5.3×10 <sup>-3</sup>	8.6×10 <sup>-6</sup>	3.5×10 <sup>-6</sup>	1.9×10 <sup>-6</sup>	1.2×10 <sup>-6</sup>	9.1×10 <sup>-7</sup>
M (W)	3.4×10 <sup>-4</sup>	8.5×10 <sup>-3</sup>	1.1×10 <sup>-2</sup>	7.5×10 <sup>-3</sup>	4.6×10 <sup>-3</sup>	6.2×10 <sup>-6</sup>	2.6×10 <sup>-6</sup>	1.4×10 <sup>-6</sup>	9.4×10 <sup>-7</sup>	6.8×10 <sup>-7</sup>
N (WNW)	2.9×10 <sup>-3</sup>	9.2×10 <sup>-3</sup>	1.6×10 <sup>-1</sup>	5.0×10 <sup>-2</sup>	8.3×10 <sup>-3</sup>	6.4×10 <sup>-6</sup>	2.7×10 <sup>-6</sup>	1.5×10 <sup>-6</sup>	9.9×10 <sup>-7</sup>	7.2×10 <sup>-7</sup>
O (NW)	2.2×10 <sup>-3</sup>	2.1×10 <sup>-2</sup>	1.6×10 <sup>-1</sup>	3.0×10 <sup>-2</sup>	2.5×10 <sup>-3</sup>	8.2×10 <sup>-6</sup>	3.5×10 <sup>-6</sup>	1.8×10 <sup>-6</sup>	1.1×10 <sup>-6</sup>	8.2×10 <sup>-7</sup>
P (NNW)	4.0×10 <sup>-3</sup>	8.5×10 <sup>-2</sup>	6.3×10 <sup>-2</sup>	9.7×10 <sup>-3</sup>	6.3×10 <sup>-3</sup>	1.1×10 <sup>-5</sup>	4.7×10 <sup>-6</sup>	2.3×10 <sup>-6</sup>	1.5×10 <sup>-6</sup>	1.0×10 <sup>-6</sup>

a. Sector letter is letter shown on Figure 4-1. Letters in parentheses after the sector letter indicate the compass direction of the sector.

impacts to a low-population community close to the SRS with a high dose per person would be diluted and masked by including it with a high-population community farther from the SRS, the analysis made comparisons within a series of concentric circles, the radii of which increase in 10-mile increments.

To determine the radiation dose received per person in each type of community, DOE multiplied the number of people in each tract by that tract's dose value to obtain a total population dose for each tract. DOE summed these population doses for each type of community over each concentric circle and divided by the total community population to obtain a community per capita dose for each circular area. Because the per capita dose for communities (Table 4-32) would be constant for all alternatives, the relative differences in impacts between any identified communities also would remain constant for all alternatives. Thus, Figure 4-8 and Table 4-33 show the distribution of per capita dose to types of communities within the 50-mile region. As shown in Figure 4-8, this analysis indicates that releases would not disproportionately affect minority communities (population equal to or greater than 35 percent of the total population) or low income (equal to or greater than 25 percent of the total population) in the 50-mile region; that is, when the per capita doses are compared horizontally in Figure 4-8, the per capita doses do not vary greatly.

For illustrative purposes, DOE used an annual total population dose of 1 person-rem to prepare Figure 4-8 and its supporting data in Table 4-33. For any other population dose, the per capita dose for identified communities can be determined by multiplying that population dose by the numbers in Table 4-33.

Sections 4.1.2 and 4.1.3 discuss predicted potential doses to the downstream population from exposure to water resources and to the offsite maximally exposed individual, respectively. Those doses reflect people using the Savannah River for drinking water, sports, and food (fish). Because the identified communities

in the areas downstream from the SRS are well distributed, there would be no disproportionate impacts among minority or low-income communities.

The distribution of carcinogenic and criteria pollutant emissions due to routine operations, and of criteria pollutants from construction activities, would be essentially identical to those presented for airborne radiological emissions because distribution pathways would be the same. As a result, minorities or low-income communities would not be disproportionately affected by nonradiological emissions from any of the alternatives. Because nonradiological pollutant emissions would have only minimal impacts for any of the alternatives, and would not be disproportionately distributed among types of communities, there are no environmental justice concerns related to these pollutants for any of the alternatives.

#### 4.4 Impacts of Electric Power Supply

The APT will require large amounts of electricity to operate. The Department is considering either purchasing electricity from existing sources and through market transactions, or obtaining from a new electricity power generating plant. If a new generating plant is required, appropriate NEPA analyses would be performed and tiered to this document.

Under the existing capacity and market transaction scenario, assuming the projected mix of electricity generation sources for the years 2005-2007, potential incremental environmental impacts would increase by 1 to 3 percent. If a new electricity generating plant is constructed, potential impacts would depend upon its location. Section 4.4.2 describes representative impacts, assuming SRS is the location for a new plant. In this case, impacts would likely be larger on a local basis than purchasing electricity from existing capacity which would have the effect of decentralizing the impacts.



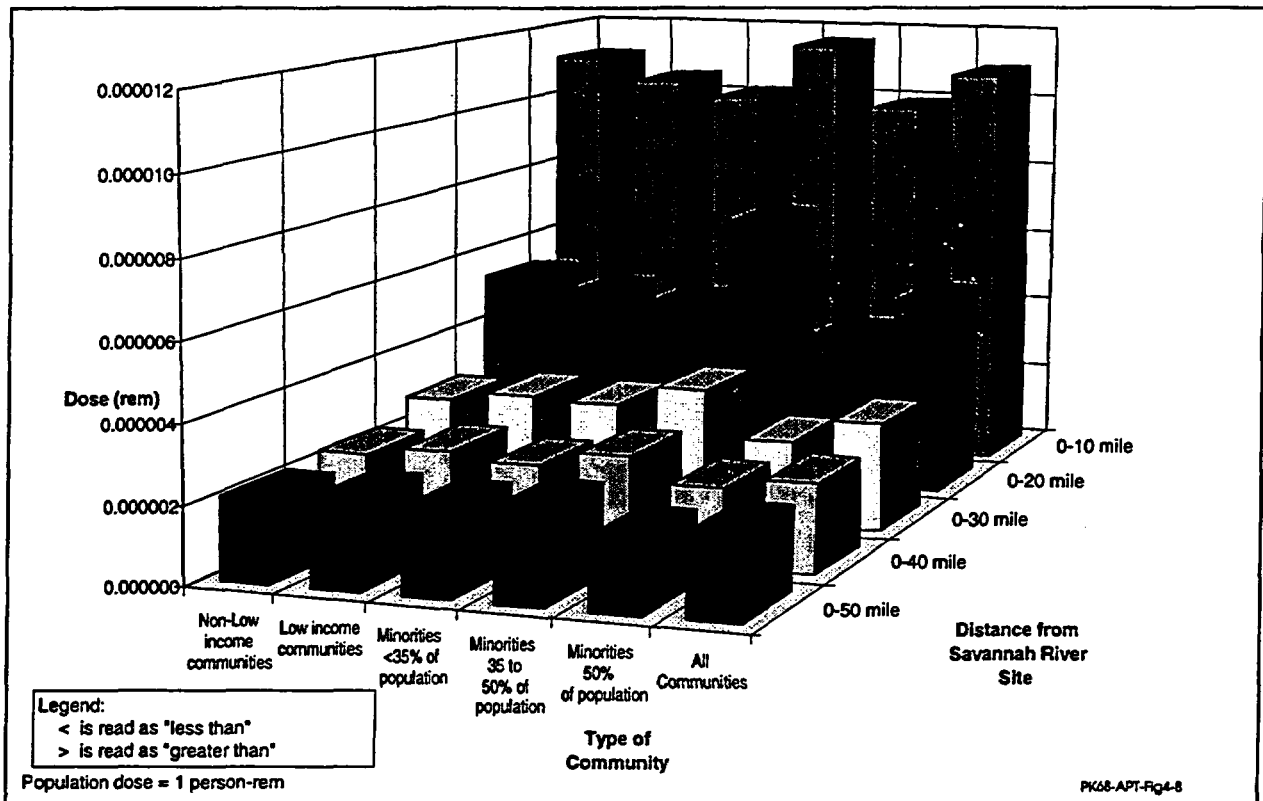

Figure 4-8. Community impacts from a unit population dose.

Table 4-33. Estimated per capita annual dose for identified communities in 50-mile region.<sup>a</sup>

Distance	Less than 25 percent of population	Equal to or more than 25 percent of population	Less than 35 percent of population	35 percent to 50 percent of population	Equal to or more than 50 percent of population	All communities
0-10 miles	0.000011	0.000010	0.000010	0.000012	0.000010	0.000011
0-20 miles	0.000005	0.000005	0.000005	0.000007	0.000004	0.000005
0-30 miles	0.000003	0.000003	0.000003	0.000003	0.000002	0.000003
0-40 miles	0.000002	0.000002	0.000002	0.000003	0.000002	0.000002
0-50 miles	0.000002	0.000002	0.000002	0.000002	0.000002	0.000002

a. Per capita dose based on a population dose of 1 person-rem. Per capita doses for other population doses can be obtained by multiplying the values in this table by the population dose.

This section describes representative environmental impacts that could occur from supplying electric power to the APT facilities, from a combination of purchasing electricity through wholesale market transactions and existing regional capacity or from the construction of a

new electric generating plant. The assessment is based on the Preferred alternative (superconducting accelerator using klystrons). Electricity requirements would be less for the Inductive Output Tube alternative and more for the Room Temperature alternative.

The analysis provides information on potential impacts associated with the power supply alternatives and issues that would be included in future NEPA documents. The analysis quantifies impacts where appropriate and compares the Power Purchase/Existing Capacity alternative and the New Electricity Generating alternative, along with two options for a new plant -- coal-fired and natural-gas-fired.

Section 4.4.1 discusses potential environmental impacts of the Power Purchase alternative, and Section 4.4.2 addresses new electricity generating plants. Section 4.4.3 compares the electric power supply alternatives.

**4.4.1 ELECTRICITY FROM EXISTING CAPACITY AND THROUGH MARKET TRANSACTIONS**

Under this alternative, electricity for the APT facilities would come from a combination of existing capacity and purchases on the wholesale power market rather than a newly constructed, dedicated power plant (Exeter 1996). A number of generation sources would provide this power, rather than a single dedicated generation source such as the new coal-fired and natural-gas-fired powerplant options.

The Department is having discussions with the South Carolina Electric & Gas Company (SCE&G) concerning acquiring the electricity required for the APT. Currently, SCE&G has indicated no plans to build a new electricity generating facility to meet APT power demands. Rather than constructing a new facility, power could be obtained from the wholesale market. Should SCE&G agree to serve in a wholesale marketing role, a pilot program could be instituted early in the construction phase of the APT to begin wholesale types of purchases for testing loads. Under a marketing arrangement, approximately 50-100 Mw of electricity from firm power contracts could be supplemented with a mixture of interruptible contracts (Toole 1997).

To assess potential environmental impacts associated with acquiring electricity through existing capacity and market transactions, DOE

applied environmental impact factors that had been developed for another Environmental Impact Statement (DOE 1995c). These impact factors are the environmental releases for a variety of power generation sources normalized to power level and are used to calculate the environmental impact of the generation of electricity required for the project. The environmental impact factors were combined with energy information forecasts of electrical generation mixes for the years 2005, 2010, and 2015 (DOE 1997b).

The average generation mix for the forecasted years is assumed to be the mix that would supply the APT average load of 350 megawatts. The estimated releases that could be attributable to the accelerator and its associated facilities are listed in Table 4-41.

DOE estimated annual air emission rates but did not model concentrations because the locations of the emission sources and receptors are not known. Radiological emissions and radiological effluent indicate that nuclear reactors are part of the national generation mix.

Using DOE Energy Information Administration (EIA) national, regional, and state energy forecasts, DOE based its estimates of the relative incremental impacts associated with the APT on baseline projections for the following geographical areas:

Region	Incremental impact
South Atlantic Region <sup>a</sup>	Less than 1 percent
South Carolina and Georgia	Between 1 and 2 percent
South Carolina	Between 2 and 3 percent
Georgia	Between 1 and 2 percent

a. The South Atlantic Region Census Division includes Delaware, the District of Columbia, Florida, Georgia, Maryland, North Carolina, South Carolina, Virginia, and West Virginia.

To estimate the environmental impact of the APT power supply on a regional scale as opposed to the U.S., a baseline was established by

applying the assumed representative generation mix used for the U.S. assessment to the regional power generation forecasts. These relative increases are independent of the power generation mix since the environmental impact multipliers are applied as constants to both the baseline and the APT-adjusted baseline. These incremental impacts would be relatively small when compared to baseline projections. The estimated impacts assume that electricity generation (based on the applied mix) would occur in that region and does not account for potential shifts in generation mix due to such factors as changes in fuel prices.

#### 4.4.2 CONSTRUCTION AND OPERATION OF NEW ELECTRICITY GENERATING PLANT

The Tritium Supply PEIS (DOE 1995c) identified two types of electricity generation -- coal-fired and natural-gas-fired -- as reasonable options if DOE chose to construct and operate a new plant to provide electricity for the APT facilities. The Tritium Supply PEIS identified these sources but indicated the uncertainties about the type of plant that would be built if needed. This EIS provides an assessment of the options; however, the type, size, and location of a powerplant in consultation with commercial utilities through which the action could possibly be privatized, and would perform engineering, technical, and detailed environmental evaluations (appropriate NEPA tiered to this EIS).

The following sections address the potential environmental impacts associated with representative coal- and natural-gas-fired plants. They do not address impacts that would be closely related to a specific location, such as those on threatened and endangered species, biological resources, floodplains and wetlands, prime farmland, cultural resource, visual resources, noise, and infrastructure (e.g., roads and rail) because candidate sites have not been selected. Generic issues associated with landforms, geology, and hydrogeology are discussed since issues would be essentially the same regardless of location. Future siting decisions and

site-specific National Environmental Policy Act documentation would consider such impacts.

For impact categories that are potentially more regional in nature such as impacts on air and water and waste generation, estimates of representative impacts are based on the representative plants. For assessment purposes, the SRS is the assumed location for the powerplant, consistent with the option from the Tritium Supply PEIS of constructing an electric generating plant with the APT. Where possible, this analysis uses information obtained for the Cope Coal-Fired Plant (SCE&G 1995) and the Polk Gas-Fired Plant (EPA 1994) to estimate the impacts if a similar facility is built on the SRS.

The analysis used a scaling approach to determine environmental impact factors based on both megawatt capacity and plant configuration (i.e., the number and type of operating units) that would depend on the impact factor. For example, the designs, processes, and impacts in the environmental assessment for the Cope plant (SCE&G 1995) are based on one unit scaled to the APT peak load requirement at 490 megawatts. The EIS for the Polk Plant (EPA 1994) separates the Integrated Gasification Combined Cycle unit from the Combined Cycle and Combustion Turbine units with respect to designs, processes, and impacts and were similarly scaled to the APT load requirement.

Table 4-34 compares the rated capacities of the two generic plants and fuel consumption.

**Table 4-34.** Comparison of rated capacities.

Operational factor	Coal-fired plant	Gas-fired plant
Annual electricity generation capacity	3.6 TWhrs/year	3.6 TWhrs/year
Average electricity generation	420 MW	420 MW
Peak electricity generation	490 MW	490 MW
Fuel (coal and gas consumption)	1.6x10 <sup>6</sup> tons/year	4.0x10 <sup>10</sup> cubic feet per year

The following sections provide an estimate of environmental impacts for each facility type.

#### 4.4.2.1 Landforms, Soils, Geology, and Hydrogeology

**Construction.** The magnitude of potential impacts to landforms, soils, geology, and hydrogeology would vary depending on the characteristics of the selected site. As with the APT facilities, powerplant construction would require shaping the site topography, which could include excavations for below-grade coal unloading facilities, scrubber sludge ponds, and ash disposal areas. Impacts from these actions could include soil erosion, disturbance of economically valuable geologic resources, loss of farmland, and groundwater depletion through dewatering.

DOE used the Cope and Polk plants as the baseline to determine the acreage requirements for a plant to serve the APT electricity requirements. A coal-fired plant large enough to support the APT and its related facilities could require approximately 290 acres; a natural-gas-fired plant could require about 110 acres. Intake and discharge corridors, transmission lines, and substations could require additional acreage. A natural-gas fired plant would require the construction of gas trunk lines. The selection of either type of plant on the SRS or elsewhere in the Central Savannah River Region would require the commitment of land resources and the conversion of land from its current use. In addition, the selection of a site outside the SRS boundary could result in the loss of agricultural land and displacement of homeowners.

**Operations.** During operations, a coal-fired plant could require water for scrubber ponds, ash disposal areas, and coal piles. The impacts would vary depending on site characteristics. Additional impacts could occur if groundwater is chosen as a source of cooling water. A coal-fired plant of the capacity required to support the APT facilities would require about 5,400 gallons of makeup water per minute, while a natural-gas-fired plant would require about 2,000 gallons per minute.

#### 4.4.2.2 Surface Water Resources

**Construction.** Potential surface water impacts from the construction of a coal- or gas-fired electric generating facility would include the discharge of groundwater to surface streams due to potential dewatering of excavated areas such as foundations, stream bed scouring, flooding, bank erosion, and sedimentation. The magnitude of the impacts would depend on the distance to receiving water bodies, the quality of the water bodies, and the extent the constituents of the discharge water differ from those of the receiving water.

**Operations.** Potential impacts to surface waters would include the removal of large volumes of water from the Savannah River and the discharge of heated water and nonradiological constituents to surface water bodies. DOE used the information for the Cope coal-fired plant (SCE&G 1995) and the Polk gas-fired plant (EPA 1994) to scale the likely impacts from a plant of the size required to support APT electrical needs. Table 4-35 summarizes and compares the approximate water requirements and operating parameters for both types of facility.

This analysis used cooling tower design parameters in the Cope environmental assessment to model thermal impacts from powerplant cooling water blowdown and assumed Par Pond would be the receiving water body. The analysis conservatively represents the natural-gas-fired plant.

The discharge of heated water from cooling water systems can affect the temperature, chemical makeup, and flow rate of the surface water bodies that receive them. The magnitude of the impacts depend on the design of the cooling water system, and the size, configuration, and capacity of receiving water bodies (i.e., large reservoirs versus small streams). Impacts to surface waters at the SRS would be similar to those described for the APT facilities in Section

Table 4-36. Estimated powerplant emission rates (pounds per hour).

Pollutant	Coal-fired powerplant	Natural-gas-fired powerplant
Carbon dioxide	970,000	640,000
Oxides of sulfur	1,700	1,700
Total suspended particulates	150	290
Particulate matter less than 10 microns	150	290
Carbon monoxide	990	1,400
Volatile organic compounds	14	220
Oxides of nitrogen	1,700	1,900
Lead	0.026	0.31
Beryllium	0.0006	0.017
Mercury	0.066	0.28
Trace radioactive materials (curies)	1	0

Sources: Derived from SCE&G (1995), EPA (1994), DOE (1995c), and Okamoto (1984).

Table 4-37. Estimated air quality impacts for coal- and natural-gas-fired powerplants at the Savannah River Site.

Pollutant	Averaging time	Concentration (micrograms per cubic meter)			
		SCDHEC standard <sup>a</sup>	SRS base-line <sup>b</sup>	Coal-fired powerplant increment <sup>c</sup>	Natural-gas-fired powerplant increment <sup>c</sup>
Oxides of sulfur	3-hour	1,300	690	87	37
	24-hour	365	220	18	11
	Annual	80	16	1.2	1.0
Total suspended particulates	Annual	75	43	0.11	0.75
Particulate matter (<10 microns)	24-hour	150	81	1.6	13
	Annual	50	4.80	0.11	0.75
Carbon monoxide	1-hour	40,000	5,000	69	88
	8-hour	10,000	630	24	33
Ozone (as total VOC)	1-hour	235 <sup>d</sup>	N/A <sup>e</sup>	0.9	N/A
Oxides of nitrogen	Annual	100	8.8	1.2	0.79
Lead	Max.	1.5	<0.01	<0.01	<0.01
	Quarter				
Beryllium	24-hour	0.01	<0.0001	<0.01	<0.01
Mercury	24-hour	0.25	0.0024	<0.01	<0.01

a. South Carolina Ambient Air Quality Standards.

b. Source: Shedrow (1997b). Based on 1994 SRS air emission inventory, except Beryllium and mercury, which are from the 1990 inventory.

c. Modeling results.

d. Federal Ozone standard (40 CFR 50).

e. N/A = Not available.

Table 4-35. Water requirements and operating parameters.

Parameter	Coal-fired plant	Natural-gas-fired plant
Circulating water flow rate	220,000 gallons per minute	130,000 gallons per minute
Cooling tower temperature rise	22.7°F	20°F
Blowdown rate	960 gallons per minute	380 gallons per minute
Make-up water	5,400 gallons per minute	2,000 gallons per minute
Blowdown stream temperature <sup>a</sup>	Average 76°F Maximum 92°F	Average 76°F Maximum 92°F
Annual potable water consumption	1.5 million gallons per year	0.8 million gallons per year
Annual nonpotable water consumption	2.4 billion gallons per year	0.7 billion gallons per year
Annual nonpotable water usage	4.7 billion gallons per year	1.4 billion gallons per year

a. Thermal impact modeling results.

4.1.2, because cooling water system designs would be based on the parameters of both the Savannah River, as the source of cooling water, and Par Pond, as the receiving water body. As discussed in Section 4.1.2, the discharge of additional volumes of water to Par Pond could increase the chance of resuspending Cesium-137. The level of total dissolved solids discharged by the powerplant would depend on the number of concentration cycles of the cooling water system and the chemicals added to prevent corrosion, scaling, and biological growth.

#### 4.4.2.3 Air Resources

**Construction.** The construction of a new generating facility could result in air quality impacts such as fugitive dust due to site clearing and emissions from the operation of construction equipment. The impacts would be temporary and would depend on the amount of acreage to be cleared and the type and duration of construction equipment operation, as discussed in Section 4.1.3. Other construction-related impacts could result from the need to build new transmission lines and substations; discharge corridors and outfalls; and pipelines for the natural-gas-fired plant.

**Operations.** The operation of either a coal- or natural-gas-fired plant would result in air emissions, visible plume occurrences, and salt deposition.

Potential air emission sources for the coal-fired powerplant, based on the Cope design, would include pulverized coal-fired boilers, emergency diesel generators, ash-scrubber waste silos, Number 2 fuel oil storage tanks, lime unloading from rail cars, an auxiliary boiler, coal transfer towers, lime silos, a coal storage and handling system, and vehicle traffic. In addition, the handling, conveying, and storing of coal, lime, and ash and scrubber waste would produce fugitive dust.

For the natural-gas-fired plant, based on the Polk design, combustion-related air emissions would come from combined-cycle units, combustion turbines, and the combustion of natural gas or backup Number 2 fuel oil. Table 4-36 lists the emission rates and types of emissions that would be likely from a coal- or natural-gas-fired generating facility. Table 4-37 lists the modeled concentrations from an assumed location on the SRS.

The air quality assessment evaluates the consequences of pollutants associated with the coal- and natural-gas-fired powerplants. DOE modeled powerplant emissions in compliance with the guidelines of the Environmental Protection Agency (EPA) Guideline on Air Quality Models (EPA 1993). The EPA recommended Industrial Source Complex Short Term Model (Version 3) (ISCST3) as the most appropriate

model to perform the air dispersion modeling analysis because it enables the estimation of dispersion from a combination of point, area, and volume sources. DOE provided SRS input data, including 1-year onsite meteorological data that represent Site characteristics. The analysis based source characteristics on the Cope environmental assessment (coal-fired powerplant) and the Polk EIS (natural-gas-fired powerplant). For unavailable source characteristics, the analysis assumed characteristics based on similar source configurations at other utility facilities that use similar processes.

DOE based the emission rates on an assumed annual operating factor of 85 percent. It conservatively assumed that the natural-gas-fired powerplant would burn gas and fuel oil simultaneously.

The evaluated concentrations were the maximum occurring at or beyond the SRS boundary or public access roads. In addition, the evaluation assumed that the emissions for a powerplant with incomplete source characteristics would originate from a single point source; this assumption generally results in higher concentrations than would actually occur because the emission sources are commonly separated geographically from one another.

Another potential impact from the operation of a electric power generating facility would be visible plumes (fogging) from cooling tower operations. Such plumes are a function of ambient temperature, ambient dew point, and turbulent mixing. The magnitude of plume impacts would depend on the location of receptors (e.g., the surrounding population). A comparison of representative coal- and natural-gas-fired powerplant heat loads to the assessment of cooling tower plumes in Section 4.1.3.3 indicates that the coal-fired generating plant would have a greater potential for visible plume occurrences than either the APT facilities and the natural-gas-fired powerplant.

#### 4.4.2.4 Waste Generation

**Construction.** The construction of a power generating facility would produce nonhazardous, nonradioactive wastes, including solid sanitary wastes, construction debris (mixed rubble, metals, plastics), and sanitary waste.

**Operations.** The operation of an electric generating facility would produce a number of liquid and solid waste streams. Based on the Cope design, the coal-fired plant could generate about 3.2 million gallons per day of wastewater; the natural-gas-fired plant, based on the Polk design, could generate about 290,000 gallons per day of wastewater. If a plant were built on the SRS, processes and management systems similar to those described for the APT facilities (see Section 4.1.6.1 and Appendix A) to dispose of the wastewater effluent.

The Cope environmental assessment, indicated that the coal-fired powerplant would not produce hazardous waste by burning coal to generate electricity. However, such a plant would generate some hazardous wastes, similar to those generated at any industrial facility, as a result of ancillary activities (SCE&G 1995). The Polk EIS indicated that the operation of most power generation and ancillary equipment does not generate hazardous wastes, as regulated under Subtitle C of the Resource Conservation and Recovery Act, although generation facilities use process-related-chemicals and other materials that typically contain small amounts of hazardous constituents.

The Polk EIS assumed a routine hazardous waste generation rate equivalent to a small quantity generator (between 100 and 1000 kilograms per month). However, it also indicated that, during periods of shutdown or high maintenance, such a facility could generate larger quantities of hazardous wastes, greater than 1,000 kilograms per month. These projections would also apply to a coal-fired powerplant.

Hazardous wastes from powerplant maintenance activities would include waste oils containing solvent residuals, waste paint and paint thinner, solvents and degreasers, and some expendable components of machinery and equipment, such as batteries.

The combustion of pulverized coal in conventional coal-fired boilers results in the generation of fly ash and bottom ash. For the coal-fired powerplant, about 80 percent of the ash produced in the coal-fired units would leave the furnace in the flue gas stream as fly ash, leaving about 20 percent in the form of bottom ash. The coal-fired powerplant would produce no hazardous solid wastes by burning coal to generate electricity.

Scrubber operations used to clean flue gases would generate calcium sulfite and sulfate. The combination of fly ash and calcium sulfite and sulfate would result in a solid waste. The constituents of scrubber waste are about 50 percent fly ash and 50 percent calcium sulfite and sulfate.

Pyrites would be mixed with the bottom ash and placed in the ash waste area. Pyrites are materials with a high iron content separated from coal during the pulverizing process.

The treatment of plant wastewater would also generate solid wastes. Solids that settled in a holdup basin would be placed in the ash storage area. Solids that settled in a coal pile runoff basin would be returned to the coal pile. Solids that settled in the ash and scrubber waste runoff basin would be returned to their respective basins.

Table 4-38 lists estimated quantities for each solid waste type that a coal-fired plant would be likely to generate.

#### 4.4.2.5 Human Health

The two main issues related to human health effects from the generation of electric power are air pollution (the release of gases and particulate

**Table 4-38.** Estimated coal-fired solid waste generation.

Waste type	Quantity (tons per year)
Bottom ash	26,000
Pyrites	9,600
Fly ash	110,000
Scrubber waste	150,000
Holdup basin solids	16
Total solid wastes	290,000

matter from incomplete fuel combustion) and electromagnetic fields.

Scientists have conducted significant research on the relationship between air pollution and health effects to humans in terms of mortality, hospitalization for respiratory and heart disease, aggravation of asthma, incidence and duration of respiratory symptoms, lung function, and restricted activity. While the research shows evidence of a statistical association between air pollution and health effects, causal relationships are nonconclusive (Wilson and Spingler 1996). In general, the effects of air pollution appear to reduce the lung function in an irreversible way. Lung functions decline with age, and in the presence of air pollution, pulmonary ailments occur at an earlier age than otherwise (Wilson 1996). Applying the results of previous studies conducted in the United States (which suggest that 70,000 persons die early through air pollution) and assuming that one-third arise from coal-fired electricity generation produces a coefficient of 100 deaths per gigawatt hour (Wilson 1996). The health effects from the operation of a gas-fired facility would be less because the gaseous and particulate emissions would be much less than those from a coal-fired plant. The Polk EIS (EPA 1994) discusses health effects associated with natural-gas-fired turbines.

The other potential health effect associated with electric power generation is exposure to electromagnetic fields, potentially resulting in certain types of cancer. Transmission lines create these fields, which are a function of the amount



of current carried by the line and the height of the conductors above the ground. Some epidemiological evidence suggests an association between magnetic field exposure and illness but the body of evidence is not conclusive (American Cancer Society 1997).

**4.4.2.6 Socioeconomics**

As discussed above, the Preferred alternative is that the APT electricity demand would be met through capacity and market transactions. This section examines the regional socioeconomic impacts of constructing and operating a commercial electricity generating plant fueled by either coal or natural gas.

The analysis does not include a review of the effect of such a generating facility on regional electric rates or other economic implications of expanding the regional electricity generating capacity. In addition, it does not address costs of building a generating plant except as the effects of expanding the work force for construction and operation.

Work force estimates for construction and operation of the coal-fired electricity generating plant are derived from the Cope environmental assessment (SCE&G 1995). The estimates are for construction and operation of two of the three units discussed in that assessment. Estimates for operations work force for the natural-gas-fired electricity generating plant are from the Western Area Power Administration (DOE 1995c). The natural-gas-fired plant construction

work force figures are scaled from the coal-fired plant workforce by use of a conversion factor (DOE 1995c). These two documents provide a planning basis for estimating impacts and are not intended to represent actual staffing of a specific facility. Those decisions would be made, as necessary, by the organization responsible for construction and operation of the generating facility.

**Coal-Fired Electricity Generating Plant.**

Table 4-39 shows the construction, startup, and operating work force by SIC category of the coal-fired plant. These numbers are added to the Preferred alternative for the economic analysis (see Table 4-29).

**Construction.** The analysis showed an increase in regional employment, population, total personal income, Gross Regional Product, and state and local expenditures over both the No Action and Preferred alternatives. The average annual rates of growth for employment and population (0.44 percent and 0.67 percent, respectively) during the construction phase would still be less than for the 4 years prior to the analysis period. Similarly, annual rates of growth for total personal income, Gross Regional Product, and state and local expenditures would be 1.59 percent, 1.14 percent, and 1.88 percent, respectively, which are less than the historic values. See Table 4-30. The impacts would not institute a boom and would not adversely strain regional infrastructure or services.

**Table 4-39. Coal-fired electricity generating plant work force.<sup>a</sup>**

SIC Category	Year										
	1	2	3	4	5	6	7	8	9	10	11
Construction	0	0	0	77	444	1,030	485	0	0	0	0
Utility							75	149	149	149	149
Total <sup>b</sup>	0	0	0	77	444	1,030	560	149	149	149	149

Total (Utility)	Year										
	12	13	14	15	16	17	18	19	20	21	After
Total (Utility)	149	149	149	149	149	149	149	149	149	149	149

a. Source: SCE&G 1995.

b. Power plant work force only, does not include preferred option.

Figures 4-9 through 4-13 show the differences of the economic measures between the No Action alternative and the APT Preferred and electricity generating alternatives.

The estimated construction work force for the generating facility would peak at approximately 1,000 in year 6 of the analysis, the same year as the peak for construction of the APT under the alternatives. This could cause a shortage of workers in the regional construction industry. During years 5 through 8, employment in the construction sector under the coal plant alternative probably would exceed current employment in that construction sector. Growth in this sector would occur between years 2 and 7 of the analysis, when construction employment would increase from 16,100 to 18,400, 14.3 percent over 5 years.

During the construction phase, regional employment and population under this alternative would at their peaks be approximately 1,900 and 1,200, respectively, greater than under the APT Preferred alternative. These measures would be approximately 4,000 and 4,300 higher than under the No Action alternative.

The short-term increases in regional demand for construction could have some localized impacts on the rental property market because there would be a temporary immigration of construction workers. As construction of the accelerator and, to a lesser extent, the powerplant would require specialized work forces, this peak demand would add further to the need to import workers in the industry. However, the overall slow growth in employment and population during this period should provide sufficient slack to accommodate newcomers to the region. Otherwise, the regional impacts from the coal-fired electricity generating plant would be much the same as those discussed for the APT Preferred alternative. See Section 4.3.2.1

**Operations.** In the long run, regional employment and population under the coal alternative would be approximately 440 and 850 higher, respectively, than those for the APT Preferred alternative. These two long-term measures for the coal-fired plant alternative would be approximately 1,300 and 2,600 higher, respectively, than those for the No Action alternative.

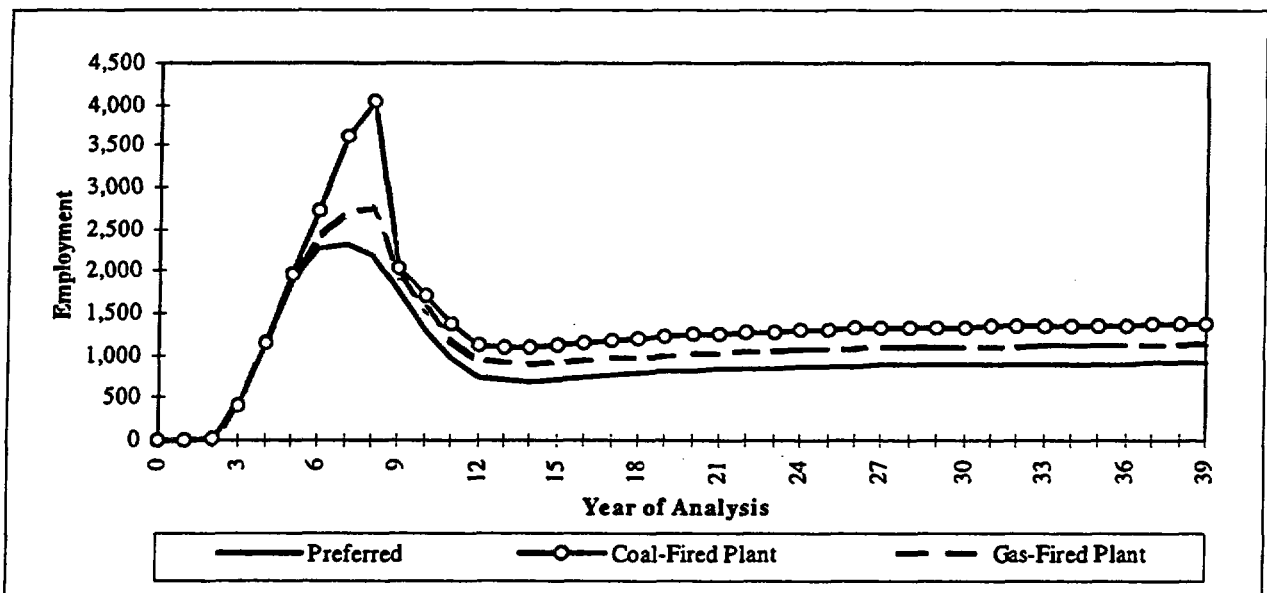

Figure 4-9. Employment differences for electricity generating and APT Preferred alternatives from No Action alternative.

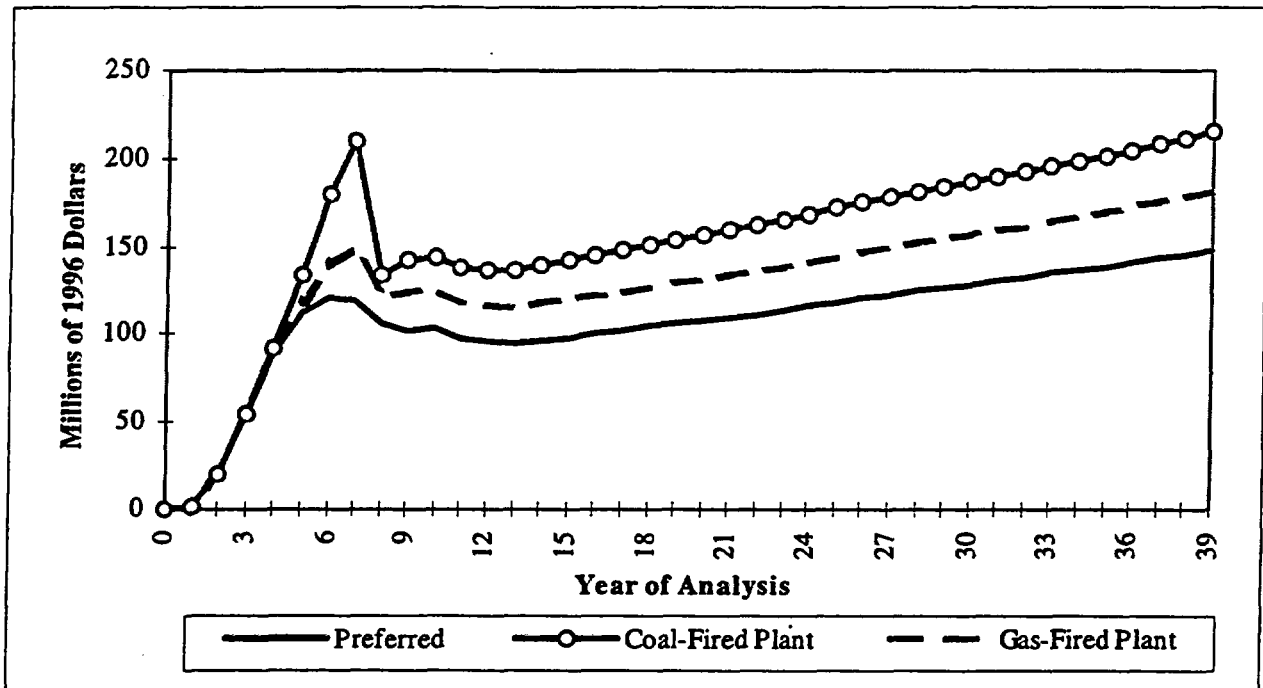

Figure 4-12. Gross regional product differences for electricity generating and APT Preferred alternatives from No Action alternative.

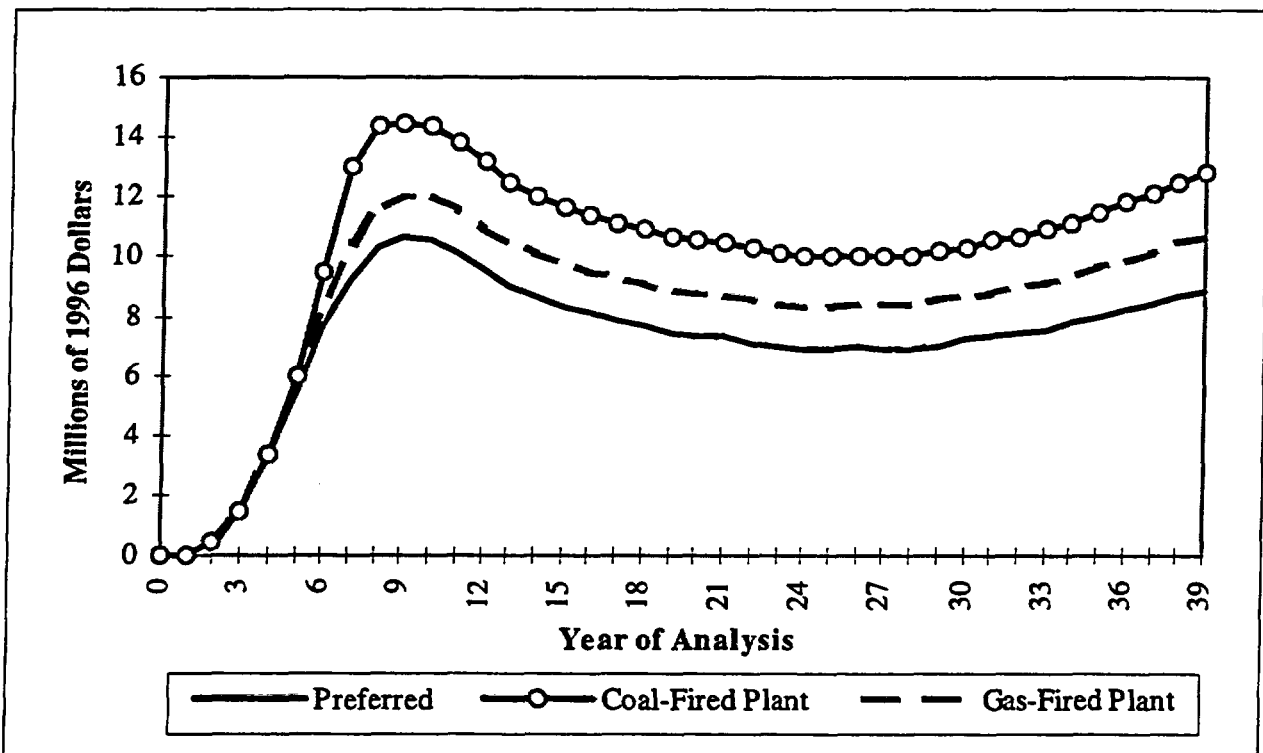

Figure 4-13. State and local government expenditure differences for electricity generating and APT Preferred alternatives from No Action alternative.

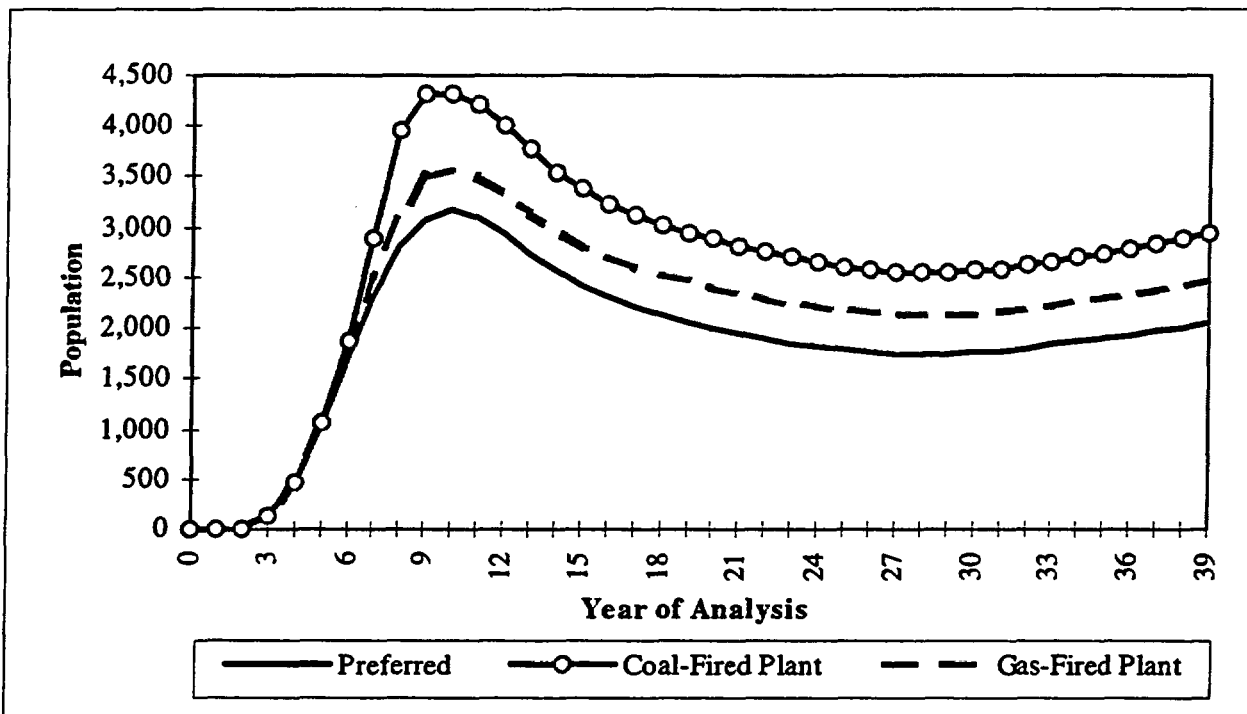

Figure 4-10. Population differences for electricity generating and APT Preferred alternatives from No Action alternative.

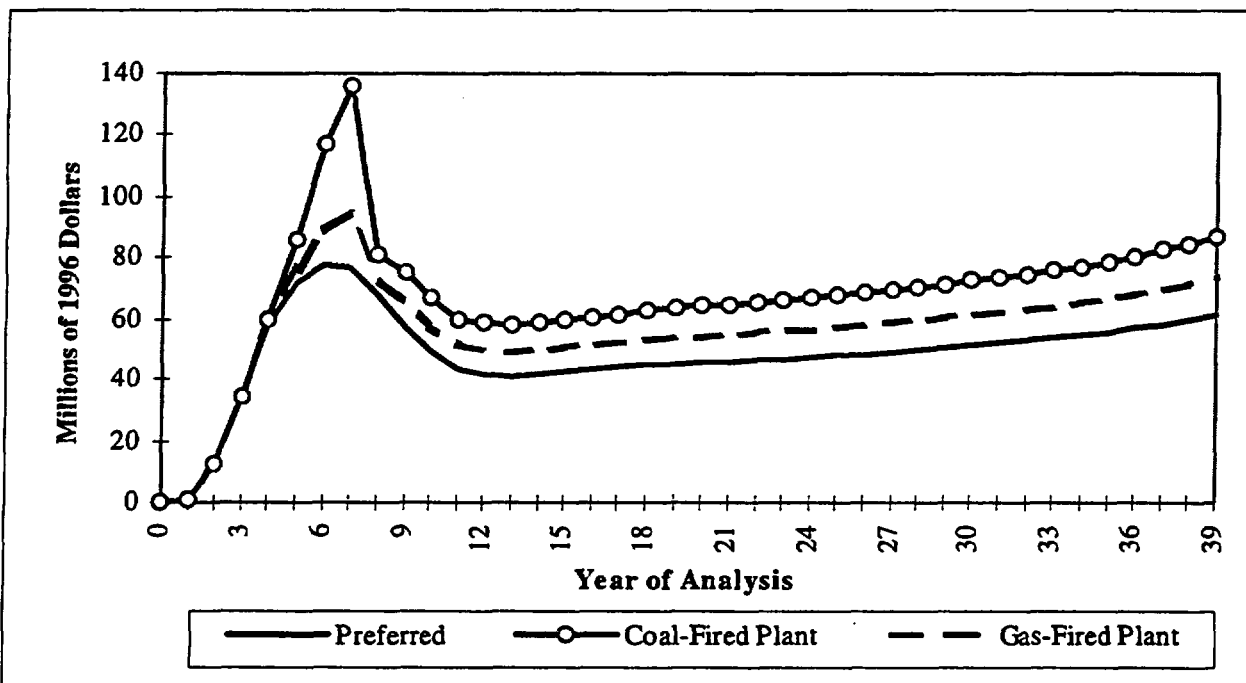

Figure 4-11. Total personal income differences for electricity generating and APT Preferred alternatives from No Action alternative.

Total personal income, Gross Regional Product, and state and local expenditures would be approximately \$21, \$51, and \$5 million higher, respectively, than for the APT Preferred alternative at the time of APT startup. Later, total personal income and GRP for this alternative would grow slightly faster than under the APT Preferred alternative. State and local government expenditures would remain approximately \$3 million higher under this alternative than under the APT Preferred alternative.

**Natural Gas-Fired Generating Plant.** Table 4-40 shows the construction, startup, and operating work force by SIC category of the natural gas-fired electricity generating plant. These numbers are added to the work force for the APT Preferred alternative for the economic analysis. See Tables 4-29 and 4-31.

**Construction.** Changes under this alternative would be greater than those for the APT Preferred alternative, but less than those for the coal-fired plant alternative. Regional employment and population under the gas-fired plant alternative would be approximately 600 and 400, respectively, higher than those for the APT Preferred alternative; and about 2,750 and 3,550, respectively, higher than those under the No Action alternative. Total personal income, Gross Regional Product, and total state and local expenditures would be only \$18 million, \$29 million, and \$1 million, respectively, greater

than those for the APT Preferred alternative. Because the construction and operation work forces of a gas-fired electricity generating plant would be smaller than those for a coal-fired plant, localized impacts to the construction industry would be less under this alternative than under the coal-fired plant alternative. Otherwise, the impacts would be much the same as for the APT Preferred alternative. See Section 4.3.1.1.

**Operations.** Long-term effects of the gas-fired plant would be slightly higher than for the APT Preferred alternative. Regional employment and population would be only approximately 200 and 380 higher, respectively, while total personal income and Gross Regional Product would be approximately \$19 million and \$25 million higher, respectively. Total state and local government expenditures would be only \$1 million higher. The impacts would be much the same as those for the APT Preferred alternative. See Section 4.3.1.2.

#### 4.4.3 COMPARISON OF POWER SUPPLY ALTERNATIVES AND POWERPLANT OPTIONS

This section compares the potential environmental impacts associated with the two electric power supply options and new powerplant options. Table 4-41 compares the Existing Capacity and Market Transactions alternative and

Table 4-40. Natural gas-fired electricity generating plant work force.<sup>a,b</sup>

SIC Category	Year										
	1	2	3	4	5	6	7	8	9	10	11
Construction	0	0	0	23	132	307	144	0	0	0	0
Utility							37	73	73	73	73
Total <sup>b</sup>	0	0	0	23	132	307	181	73	73	73	73

Total (Utility)	Year										
	12	13	14	15	16	17	18	19	20	21	After
Total (Utility)	73	73	73	73	73	73	73	73	73	73	73

<sup>a</sup> Source: DOE 1995c.

<sup>b</sup> Power plant work force only; does not include Preferred alternative.

Table 4-41. Projected environmental impacts for APT electric power supply alternatives.

Factor	Value		
	Existing Capacity/Market Transactions alternative	New Powerplant alternative	
		Coal-fired powerplant option <sup>a</sup>	Natural-gas-fired powerplant option <sup>a</sup>
Air emissions (pounds per year)			
Carbon dioxide	6,900,000,000	7,200,000,000	4,700,000,000
Sulfur oxides as SO <sub>2</sub>	2,200,000	12,000,000	13,000,000
Nitrogen oxides as NO <sub>2</sub>	8,100,000	12,000,000	14,000,000
Volatile organic compounds	2,100,000	100,000	1,600,000
Carbon monoxide	6,700,000	7,300,000	10,000,000
Particulate matter (PM <sub>10</sub> )	1,400,000	1,100,000	2,100,000
Radioactive emissions (curies)	2,000	1	0
Water consumption (acre-feet)	2,100	11,700	1,900
Liquid radioactive effluent (curies)	19,000	0	0
Solid waste (pounds per year)			
Ash	32,000,000	260,000,000	
Total metals	310,000	19,000,000	
Nuclear solid waste	10,000	0	0
Additional land use (acres)	N/A	290	110
Construction employees (work-years)	N/A	1,097	308
Operations (employees per year)	225	184	110

a. Annual values based on 85 percent capacity factor, even though APT should use only 70 percent of annual production.

N/A - Not applicable.

the New Powerplant alternative. Table 4-42 compares the resource consumption for the two powerplant options (coal and natural gas).

In general, the Existing Capacity/Market Transactions alternative would result in a lower level of impacts in comparison to either new powerplant option due to the opportunity to use a mix of existing generating capacity (e.g., the inclusion of some hydro which is essentially non-polluting). In addition, this alternative could disburse environmental impacts over a number of regions, which would decrease the relative impact on affected environmental resources and the public in comparison to a new powerplant in a single location.

A coal-fired powerplant would use more land because it would require an ash scrubber waste area and coal storage facilities. A natural-gas-

fired powerplant would require the construction of pipeline to transport fuel from the gas transmission system; the coal-fired plant would use existing SRS rail capacity to transport coal. As mentioned above, the level of the impacts attributed to fuel transportation would depend on the location of the site and its proximity to accessible rail and pipeline infrastructure. The coal-fired plant would produce higher sulfur dioxide concentrations due to the higher sulfur content of coal in comparison to natural gas. The heat dissipation system at the coal-fired plant would require more water than the gas-fired plant due to the increased heat load. The coal plant would use steam turbines to generate electricity and the gas-fired plant would use steam turbines only in conjunction with the heat recovery steam generators that recover exhaust heat from the combustion turbines.

**Table 4-42. Projected resource consumption for APT electric powerplant options.**

Factor	Coal-fired powerplant	Natural-gas-fired powerplant
Land (acres)	290	110
Water (gallons per day)	4,700,000,000	1,400,000,000
Fuel	1,600,000 tons/year	4.0x10 <sup>10</sup> cubic feet/year

## References

- Aho, J. M., and C. S. Anderson, 1985, *Fish Population in Pond C: Dynamics of the Fish Kills (a Preliminary Report)*, SWED-85/1209, Savannah River Ecology Laboratory, Aiken, South Carolina.
- Aho, J. M., C. S. Anderson, and J. W. Terrell, 1986, *Habitat Suitability Index Models and Instream Flow Suitability Curves: Redbreast Sunfish*, U.S. Fish and Wildlife Service, Fort Collins, Colorado
- American Cancer Society, 1997, "Cancer Facts & Figures - 1997: Environmental Cancer Risks," paper downloaded from the internet site of the American Cancer Association at <http://www.cancer.org/statistics/97cff/97enviro.html> on September 14, 1997.
- American Fisheries Society, 1979, *A Review of the EPA Red Book: Quality Criteria for Water*, Water Quality Section, American Fisheries Society, Bethesda, Maryland.
- Arnett, M. W., 1993, *Savannah River Site Environmental Data for 1992*, WSRC-TR-93-077, Westinghouse Savannah River Site, Aiken, South Carolina.
- Arnett, M. W., 1994, *Savannah River Site Environmental Data for 1993*, WSRC-TR-94-077, Westinghouse Savannah River Site, Aiken, South Carolina.
- Arnett, M. W., 1995, *Savannah River Site Environmental Data for 1994*, WSRC-TR-95-077, Westinghouse Savannah River Site, Aiken, South Carolina.
- Arnett, M. W., 1996, *Savannah River Site Environmental Data for 1995*, WSRC-TR-96-077, Westinghouse Savannah River Site, Aiken, South Carolina.
- Arnett, M. W., 1997, *Savannah River Site Environmental Data for 1996*, WSRC-TR-97-077, Westinghouse Savannah River Site, Aiken, South Carolina.
- Arnett, M. W. and A. R. Mamatey, 1996, Savannah River Site Environmental Report for 1995, WSRC-TR-96-0075, Westinghouse Savannah River Company, Savannah River Site, Aiken, South Carolina.
- Bennett, D. H., and R. W. McFarlane, 1983, *The Fishes of the Savannah River Plant: National Environmental Research Park*, SRO-NERP-12, Savannah River Ecology Laboratory, Aiken, South Carolina.
- Brisbin, I. L., 1997, "Impact of APT Proposed Alternatives on Par Pond Alligators," personal communication with Y. F. Abernethy (Halliburton NUS Corporation), Savannah River Ecology Laboratory, Aiken, South Carolina, August 13, 1997.
- Carlander, K. D., 1969, *Handbook of Freshwater Fishery Biology*, Volume Two, Iowa State University Press, Ames, Iowa, 431 pp.
- Christy, E. J., J. O. Farlow, J. E. Bourque, and J. W. Gibbons, 1974, "Enhanced Growth and Increased Body Size of Turtles Living in Thermal and Post-Thermal Aquatic Systems," in *Thermal Ecology*, J. W. Gibbons and R. R. Sharitz (eds.), CONF-130505, U.S. Atomic Energy Commission, pp. 277-284.
- Chun, K. C. and J. Rabchuk, 1991, *Environmental Impacts of Noise from Construction and Operation of NPR Facilities at the Three Candidate Sites*, Argonne National Laboratory, Argonne, Illinois.



- Cooney, T. W., K. H. Jones, P. A. Drewes, J. W. Gissendanner, and B. W. Church, 1995, *Water Resources Data South Carolina Water Year 1995*, USGS-WDR-SC-95-1, U. S. Geological Survey, Water Resources Division, Columbia, South Carolina.
- Cooney, T. W., K. H. Jones, P. A. Drewes, J. W. Gissendanner, and B. W. Church, 1996, *Water Resources Data, South Carolina Water Year 1996*, USGS-WDR-SC-96-1, U.S. Geological Survey, Water Resource Division, Columbia, South Carolina.
- Coutant, C. C., 1977, "Compilation of temperature preference data," *Journal of the Fisheries Research Board of Canada*, Volume 34, pages 139-745.
- Cvancara, V. A., S. F. Stieber, and B. A. Cvancara, 1977, "Summer Temperature Tolerance of Selected Species of Mississippi River Acclimated Young of the Year Fishes," *Comparative Biochemical Physiology*, Volume 56A, pages 81-85.
- Dahlberg, M. D., and J. C. Conyers, 1974, "Winter fauna in a thermal discharge with observations on a macrobenthos sample," in *Thermal Ecology*, Proceedings of a symposium held at Augusta, Georgia, May 3-5, 1973, U.S. Atomic Energy Commission.
- DiFiore-Smith, L., 1997a, *Par Pond Hydrological Model: Proposed APT Process, Run 2*, Savannah River Institute, New Ellenton, South Carolina.
- DiFiore-Smith, L., 1997b, *Estimated Impacts on Lower Three Runs by the Proposed APT Process*, Savannah River Institute, New Ellenton, South Carolina.
- DOE (U.S. Department of Energy), 1987a, *Final Environmental Impact Statement, Alternative Cooling Water Systems*, DOE/EIS-0121, Savannah River Field Office, Aiken, South Carolina.
- DOE (U.S. Department of Energy), 1987b, *Impingement and Entrainment at the River Water Intakes of the Savannah River Plant*, Savannah River Field Office, Aiken, South Carolina.
- DOE (U.S. Department of Energy), 1990, *Final Environmental Impact Statement for the Continued Operation of K-, L-, and P-Reactors, Savannah River Site, Aiken, South Carolina*, DOE/EIS-0147, Savannah River Field Office, Aiken, South Carolina.
- DOE (U.S. Department of Energy), 1995a, *Environmental Assessment for the Construction and Operation of the Three Rivers Solid Waste Authority, Regional Waste Management Center at the Savannah River Site*, DOE/EA-1079, Savannah River Operations Office, Aiken, South Carolina.
- DOE (U.S. Department of Energy), 1995b, *Final Savannah River Site Waste Management Environmental Impact Statement*, DOE/EIS-0217, Savannah River Operations Office, Aiken, South Carolina.
- DOE (U.S. Department of Energy), 1995c, *Energy Planning and Management Program Environmental Impact Statement*, DOE/EIS-0182, Western Area Power Administration, Golden, Colorado.
- DOE (U.S. Department of Energy), 1997a, *Final Environmental Impact Statement, Shutdown of the River Water System at the Savannah River Site*, DOE/EIS-0268, Savannah River Operations Office, Aiken, South Carolina.
- DOE (U.S. Department of Energy), 1997b, *Annual Energy Outlook 1997 with Projections to 2015*, DOE/EIA-0383(97), Energy Information Administration, Washington, D.C.

- Drew, H. R. and J. E. Tilton, 1970, "Thermal requirements to protect fish in Texas reservoirs," *Journal of the Water Pollution Control Federation*, Volume 42, pages 562-572.
- Durrett, C. W., and W. D. Pearson, 1975, "Drift of macroinvertebrates in a channel carrying heated water from a power plant," *Hydrobiologia* 46:33-43.
- England, J. L., 1997, APT Waste Management White Paper on *APT Generation of Long-Lived Radionuclides to Include Greater than Class C Low-Level Radioactive Waste Requiring Special Disposal Considerations*, WSRC-TR-97-0259, Aiken, South Carolina, August 20.
- EPA (U.S. Environmental Protection Agency), 1985, *Compilation of Air Pollutant Emission Factors, Volume I: Stationary Point and Area Sources*, AP-42, Washington, D.C.
- EPA (U.S. Environmental Protection Agency), 1986, *Quality Criteria for Water*, EPA 440/5-86-001, Office of Water Regulations and Standards, Washington D.C.
- EPA (U.S. Environmental Protection Agency), 1991, *Ambient Water Quality Criteria Summary Table*, Office of Science and Technology, Health and Ecological Criteria Division, Washington, D.C.
- EPA (U.S. Environmental Protection Agency), 1993, *Guidelines on Air Quality Models (Revised)*, Office of Air and Radiation, Office of Air Quality Planning and Standards, Research Triangle Park, North Carolina.
- EPA (U.S. Environmental Protection Agency), 1994, *Final Environmental Impact Statement, Tampa Electric Company - Polk Power Station*, EPA 904/9-94-002(a), Region IV, Atlanta, Georgia.
- Exeter, 1996, *Estimated Power Supply Costs for the Accelerator Production of Tritium Project*, Exeter Associates, Inc., Silver Spring, Maryland.
- Fikani, M., 1997, The Use of Concrete Shielding to Achieve Groundwater Activation Requirements, APT-0534, internal correspondence, APT-Burns & Roe/General Atomic, September 22.
- Gibbons, J. W., and R. R. Sharitz, 1974, "Thermal Alteration of Aquatic Ecosystems," *American Scientist*, Volume 62, pages 660-670.
- Golden, J., R. P. Ouellete, S. Saari, and P. N. Cheremisinoff, 1980, *Environmental Impact Data Book*, Ann Arbor Science Publishers, Ann Arbor, Michigan.
- Grace, J. B. and L. J. Tilly, 1976, "Distribution and Abundance of Submerged Macrophytes, Including *Myriophyllum Spicatum* L. (Angiospermae), in a Reactor Cooling Reservoir," *Archives of Hydrobiology*, Volume 77, No. 4, pages 475-487.
- Hiergesell, R., 1997, interoffice memorandum to B. Shedrow, Westinghouse Savannah River Company, Aiken, South Carolina, September 19.
- Holland, W. E., M. H. Smith, J. W. Gibbons, and D. H. Brown, 1974, "Thermal tolerances of fish from a reservoir receiving heat effluent from a nuclear reactor," *Physiological Zoology*, Volume 37, pages 110-118.

- Howell, F. G., and J. B. Gentry, 1974, "Effect of Thermal Effluents from Nuclear Reactors on Species Diversity of Aquatic Insects," in *Thermal Ecology*, J. W. Gibbons and R. R. Sharitz (eds.), CONF-730505, U.S. Atomic Energy Commission, pp. 562-571.
- Hunter, C. H., 1997, "Nonradiological Air Quality Calculations for the Accelerator Production of Tritium (APT) Environmental Impact Statement (EIS)," SRT-NTS-97-0279 (Draft), interoffice memorandum to C. B. Shedrow, Westinghouse Savannah River Company, Aiken, South Carolina.
- INTERA Environmental Consultants, Inc., 1980, *Remote Sensing for the Detection and Monitoring of Salt Stress on Vegetation: Evaluations and Guidelines*, Nuclear Regulatory Commission Report NUREG/CR-1231.
- LANL (Los Alamos National Laboratory), 1997, *Accelerator Production of Tritium Conceptual Design Report*, U.S. Department of Energy, Los Alamos, New Mexico.
- Mayer, J. J., and L. D. Wike, 1997, *SRS Urban Wildlife: Environmental Information Document (Draft)*, WSRC-TR-97-0093, Westinghouse Savannah River Company, Aiken, South Carolina.
- McFarlane, R. W., R. F. Frietsche, and R. D. Miracle, 1978, *Impingement and Entrainment of Fishes at the Savannah River Plant: an NPDES 316b Demonstration*, E. I. du Pont de Nemours and Company, Savannah River Laboratory, Aiken, South Carolina.
- McMahon, T. E., G. Gebhart, O. E. Maughan, and P. C. Nelson, 1984, *Habitat Suitability Index Models and Instream Flow Suitability Curves: Warmouth*, U.S. Fish and Wildlife Service, Fort Collins, Colorado.
- Mulchi, C. L., and J. A. Armbruster, 1981, "Response of Corn and Soybean to Simulated Saline Aerosol Drift from Brackish Water Cooling Towers," *Journal of Environmental Quality*, Vol. 10, pp. 541-547.
- Muska, C. F., and R. A. Matthews, 1983, *Biological Assessment for the Shortnose Sturgeon *Acipenser brevirostrum* Lesueur 1818*, DPST-83-754, Savannah River Laboratory, E. I. du Pont de Nemours and Company, Aiken, South Carolina.
- Nelson, D. H., 1974, "Growth and Developmental Responses of Larval Toad Populations to Heated Effluent in a South Carolina Reservoir," in *Thermal Ecology*, J. W. Gibbons and R. R. Shartz (eds.), CONF-730505, U. S. Atomic Energy Commission, pp. 264-276.
- Nelson, E. A., 1997, "Impact of APT Proposed Alternative on Pen Branch Restoration," personal communication with Y. F. Abernethy (Halliburton NUS Corporation), Westinghouse Savannah River Company, Aiken, South Carolina, September 8.
- NRC (U.S. Nuclear Regulatory Commission), 1985, *Final Environmental Statement Related to the Operation of Vogtle Electric Generating Plant Units 1 and 2*, Docket Nos. 50-424 and 50-425, Georgia Power Company, et al., NUREG-1087, Office of Nuclear Reactor Regulation, Washington, D. C., March.
- NCRP (National Council on Radiation Protection and Measurements), 1993, *Limitation of Exposure to Ionizing Radiation*, Report Number 116, Washington, D.C.
- NUS (NUS Corporation), 1990, *Sound Level Characterization of the Savannah River Site*, NUS-5251, Aiken, South Carolina.
- NUS (NUS Corporation), 1991, *Air Quality, Cooling Tower, and Noise Impact Analyses in Support of the New Production Reactor Environmental Impact Statement*, Aiken, South Carolina, March.

- NWS (National Weather Service), 1994, *Local Climatological Data - Annual Summaries for 1993 - Part II, Southern Region*, National Climatic Data Center, Asheville, North Carolina.
- Okamoto, K., 1984, Comments on "Coal Energy vs. Nuclear Energy: A Comparison of the Radiological Risk," *Health Physics*, Volume 47, Number 50, Pergamon Press, New York, November.
- Parkin, R. B., and J. B. Stahl, 1981, "Chironomidae (Diptera) of Baldwin Lake, Illinois, a cooling reservoir," *Hydrobiologia*, Volume 76, pages 119-128.
- Patrick, R., 1969, "Some Effects of Temperature on Freshwater Algae," in *Biological Aspects of Thermal Pollution*, Vanderbilt Univ. Press, pages 161-198.
- Peterson, S. E., and R. M. Shutsky, 1976, "Some Relationships of Upper Thermal Tolerance to Preference and Avoidance Responses of the Bluegill, in G. W. Esch and R. W. McFarlane (eds.), *Thermal Ecology II*, Proceedings of symposium held April 2-5, 1975, in Augusta, Georgia, pp. 148-153, U.S. Energy Research and Development Administration, CONF-750425.
- Pinder, J. E., 1997, "Historic and Current Conditions in Ponds 2 and 5," personal communication with D. E. Kennemore (Halliburton NUS Corporation), Savannah River Ecology Laboratory, Aiken, South Carolina, July 17, 1997.
- REMI, 1996, *Economic Demographic Forecasting and Simulation 53-Sector Model*, Regional Economic Model, Inc., Amherst, Massachusetts.
- SCDHEC (South Carolina Department of Health and Environmental Control, 1992, *Water Classifications and Standards* (Regulation 61-68), Office of Environmental Quality Control, Columbia, South Carolina.
- SCE&G (South Carolina Electric and Gas Company), 1995, *Environmental Assessment for Cope Power Plant*, Volume 1, Columbia, South Carolina.
- Scott, W. B., and E. J. Crossman, 1973, *Freshwater Fishes of Canada*, Bulletin 184, Fisheries Research Board of Canada, Department of Fisheries and Oceans, Ottawa, Canada.
- Shedrow, C. B., 1997a, *Submittal of Technical Data for Preparation of APT EIS*, ESH-EAP-97-0082, Westinghouse Savannah River Company, Aiken, South Carolina, August 27.
- Shedrow, C. B., 1997b, *Submittal of Technical Data for Preparation of APT EIS*, ESH-EAP-97-0048, Westinghouse Savannah River Company, Aiken, South Carolina, May 20.
- Shedrow, C. B., 1997c, *Submittal of Technical Data for Preparation of APT EIS*, ESH-EAP-97-0059, Westinghouse Savannah River Company, Aiken, South Carolina, June 16.
- Simpkins, 1997a, "APT Routine Aqueous Release Environmental Dosimetry Calculations," SRT-EST-97-377, interoffice memorandum to C. B. Shedrow, Westinghouse Savannah River Company, Aiken, South Carolina, June 25.
- Simpkins, 1997b, "APT Routine Aqueous Release Environmental Dosimetry Calculations," SRT-EST-97-388, interoffice memorandum to C. B. Shedrow, Westinghouse Savannah River Company, Aiken, South Carolina, July 24.

- Simpkins, 1997c, "APT Routine Aqueous Release Environmental Dosimetry Calculations," SRT-EST-97-395, interoffice memorandum to C. B. Shedrow, Westinghouse Savannah River Company, Aiken, South Carolina, August 6.
- Simpkins, 1997d, "APT EIS Routine Release Environmental Dosimetry Calculations - Revised Source Term," SRT-EST-97-452, interoffice memorandum to C. B. Shedrow, Westinghouse Savannah River Company, Aiken, South Carolina, August 20.
- Simpkins, 1997e, "APT EIS Routine Release Environmental Dosimetry Calculations - TEF Emissions," SRT-EST-97-400, interoffice memorandum to C. B. Shedrow, Westinghouse Savannah River Company, Aiken, South Carolina, August 15.
- Simpkins, 1997f, "APT EIS Routine Release Environmental Dosimetry Calculations - Site #6 Using H-Area Meteorology," SRT-ETS-97-461, interoffice memorandum to C. B. Shedrow, Westinghouse Savannah River Company, Aiken, South Carolina, September 26.
- Toole, G. L., 1997, "SCE&G discussions," interoffice communication to R. Reynold, U.S. Department of Energy, Savannah River Site, Aiken, South Carolina, October 23.
- Wiederholm, T., 1984, "Responses of Aquatic Insects to Environmental Pollution," in V. H. Resh and D. M. Rosenberg (eds.), *The Ecology of Aquatic Insects*, pp. 508-557, Praeger Publishers, New York.
- Wike, L. D., R. W. Shipley, A. L. Bryan, Jr., J. A. Bowers, C. L. Cunningham, R. R. del Carmen, G. P. Friday, J. E. Irwin, J. J. Mayer, E. A. Nelson, M. H. Paller, V. A. Rogers, W. L. Specht, and E. Wilde, 1994, *SRS Ecology: Environmental Information Document*, WSRC-TR-93-496, Westinghouse Savannah River Company, Aiken, South Carolina, September.
- Wilde, E. W., 1985, Compliance of the Savannah River Plant P-Reactor Cooling System with Environmental Regulations, DP-1708, E. I. du Pont de Nemours and Company, Inc., Savannah River Plant, Aiken, South Carolina.
- Wilde, E. W., and L. J. Tilly, 1985, *Influence of P-Reactor Operation on the Aquatic Ecology of Par Pond - A Literature Review*, DP-1698, E. I. duPont de Nemours and Company, Savannah River Laboratory, Aiken, South Carolina.
- Wilson, R., 1996, "Some Transboundary Environmental Issues of Public Concern," in *Electricity, Health, and the Environment; Comparative Assessment in Support of Decisionmaking*, Proceedings of a Symposium on International Atomic Energy Agency, Vienna, Austria, October 16-19.
- Wilson, R. and J. Spengler, 1996, *Particles in Our Air: Concentration and Health Effects*, Harvard School of Public Health, Cambridge, Massachusetts.
- WSRC (Westinghouse Savannah River Company), 1996a, Savannah River Site Geology/Hydrogeology Environmental Information Document, WSRC-TR-95-0046.
- WSRC (Westinghouse Savannah River Company), 1996b, *APT Cooling Water Supply Make-Up Trade Study*, Savannah River Site, Aiken, South Carolina.
- WSRC (Westinghouse Savannah River Company), 1996c, SRS Emergency Plan, SCD-7, Aiken, South Carolina.

# Chapter 5

## Cumulative Impacts

---

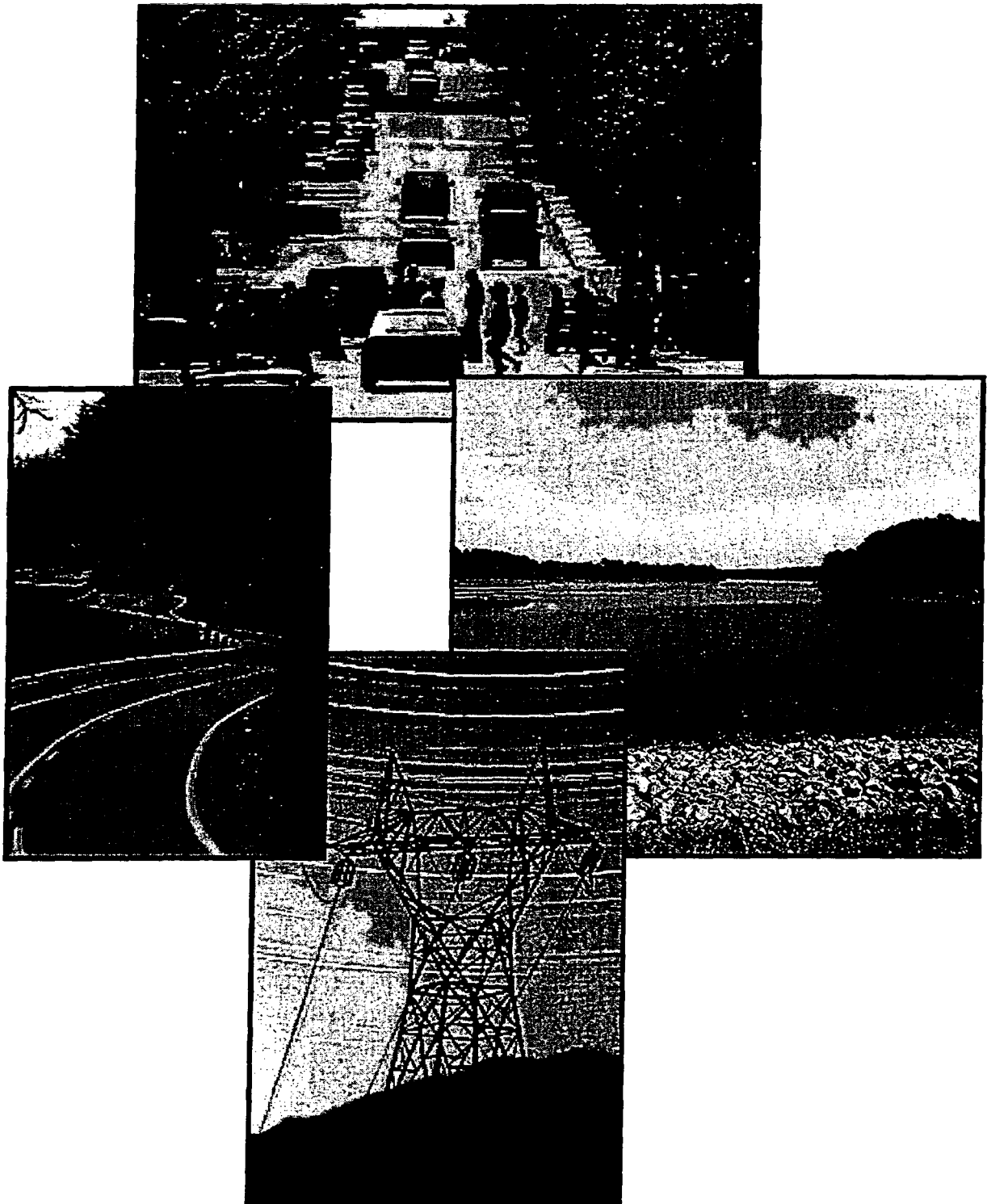

Consistent with the National Environmental Policy Act, the potential impacts associated with proposed APT Actions must be considered along with other past, present, and reasonable foreseeable actions. This is done to help determine, cumulatively, if impacts will have large and additive impacts on the environment.

## CHAPTER 5. CUMULATIVE IMPACTS

Consistent with the National Environmental Policy Act, this chapter considers past, present, and reasonably foreseeable actions that could, along with the APT, result in cumulative impacts to the environment. It considers other ongoing Savannah River Site (SRS) operations, actions that might occur in the future at SRS, the radiological impacts of Plant Vogtle (a commercial nuclear powerplant across the Savannah River from the SRS), and the consumption of electricity. With the exception of electricity consumption, construction and operation of the APT would not have large additive or incremental impacts on the environment.

The Council on Environmental Quality (CEQ) regulations that implement the procedural provisions of the National Environmental Policy Act (NEPA) define cumulative effects as impacts on the environment that result from the addition of the incremental impact of the action to other past, present, and reasonably foreseeable future actions regardless of what agency (Federal or non-Federal) or person undertakes the other actions (40 CFR 1508.7). The U.S. Department of Energy (DOE) based the cumulative impacts analysis in this chapter on actions associated with the construction and operation of a linear accelerator to produce tritium at the Savannah River Site (SRS), other actions associated with onsite activities, and offsite activities with the potential to cause related environmental impacts. This chapter describes cumulative impacts for: (1) public and worker health, (2) air resources, (3) water resources, (4) waste generation, (5) utilities and energy consumption, (6) ecological resources, and (7) socioeconomic resources.

Radiological impacts from the operation of the Vogtle Electric Generating Plant, a two-unit commercial nuclear powerplant approximately 10 miles southwest of the center of the SRS near Waynesboro, Georgia, are minimal, but DOE has factored them into the analysis. Radiological impacts from the operation of the Chem-Nuclear Services facility, a commercial low-level waste disposal facility just east of the SRS, are so small (SCDHEC 1992) that DOE has not included them in this assessment.

In addition to this environmental impact statement (EIS), DOE has prepared other recent NEPA documentation related to the SRS cumu-

lative impacts (see Section 1.6) or identified other reasonably foreseeable actions (see Section 5.8). This analysis considers the following NEPA documents related to the SRS:

- *Savannah River Site Spent Nuclear Fuel Management Environmental Impact Statement* on December 31, 1996 (61 FR 69085); a NOI was issued to prepare this EIS. To date, it has not been issued to the public. Information used in this Chapter is based on maximum values utilizing preliminary report data (Young 1997). The proposed action of this EIS is to provide additional capability at SRS to receive and prepare spent nuclear fuel for ultimate disposal at a Federal geologic repository. Specific actions needed to accomplish this include construction and operation of a Treatment and Storage Facility, a Treatment Facility, and additional dry storage capacity.
- *Defense Waste Processing Facility Supplemental Environmental Impact Statement*, (DOE 1994a); the selected alternative in the record of decision (ROD) is the completion of construction and the operation of the Defense waste Processing Facility (DWPF) to immobilize high-level radioactive waste at the SRS.
- *Savannah River Site Waste Management Final Environmental Impact Statement* (DOE 1995a); the selected alternative in the ROD involves the treatment and minimization of radioactive and hazardous wastes at the SRS.
- *Programmatic Environmental Impact Statement for Tritium Supply and Recycling* (DOE 1995b);



DOE's decision is either to pursue the purchase of an existing commercial nuclear reactor or irradiation services, or to build an accelerator to produce tritium. DOE selected the SRS as the location for an accelerator, if it decides to build one. In addition, DOE would upgrade the tritium recycling facilities to support either option. The cumulative impact data in this chapter is for the recycling (including upgrades) portion of that EIS.

- *Environmental Impact Statement - Interim Management of Nuclear Materials* (DOE 1995c); DOE has begun implementing the selected scenarios for most of the nuclear materials discussed in that EIS with the exception of selecting the "comparative management scenario" alternatives for H-Canyon Plutonium-239 solutions (process to metal), Mark-16 and -22 fuels (process and storage for vitrification at the Defense Waste Processing Facility), and other aluminum-clad fuel targets (processing and storage for vitrification at DWPF).
- *Environmental Impact Statement, Shutdown of the River Water System at the Savannah River Site* (DOE 1997); the Preferred alternative is to shut down and maintain the River Water System and to place all or portions of the system in a standby condition that would enable restart if conditions or mission changes required system operation.
- *Disposition of Surplus Highly Enriched Uranium Final Environmental Impact Statement* (DOE 1996); this cumulative impacts analysis incorporates the Maximum Commercial Use - Blending Disposition at SRS alternative from that EIS.
- *Tritium Extraction Facility*, preliminary data for this proposed SRS facility was obtained from DOE (1995d) and Simpkins (1997).

This cumulative impacts analysis includes impacts from actions proposed in this EIS. DOE based the calculated risks to members of the

public and site workers from radiological and nonradiological releases on the Preferred alternatives for the accelerator production of tritium described in Chapter 4.

In addition, this analysis includes other SRS operations. Most SRS data are based on 1995 values (Arnett and Mamatey 1996), which are the most recent available.

## 5.1 Water Resources

Table 5-1 summarizes the estimated cumulative radiological doses to human receptors from exposure to waterborne sources downstream from the SRS. Liquid effluents from the Site could contain small quantities of radionuclides that would be released to SRS streams that are tributaries of the Savannah River. The exposure pathways considered in this analysis included drinking water, fish ingestion, shoreline exposure, swimming, and boating. As discussed in Section 4.1.2, the Preferred alternative would result in an annual radiological dose of 0.0000063 rem (or 0.0063 millirem) to the maximally exposed individual at the SRS boundary from liquid releases.

The estimated cumulative dose from all SRS activities to the maximally exposed member of the public from liquid releases would be 0.00035 rem (or 0.35 millirem) per year, well below the regulatory standard of 4 millirem per year (40 CFR Part 141). Adding the population doses associated with current and projected SRS activities would yield a cumulative annual dose of 12 person-rem from liquid sources. This translates into 0.0061 latent cancer fatality for each year of exposure of the 620,000-person population living within a 50-mile radius of the SRS.

At present, a number of SRS facilities discharge treated wastewater to Upper Three Runs and its tributaries via NPDES-permitted outfalls. These include the F/H Area Effluent Treatment Facility and M-Area Liquid Effluent Treatment Facility. Studies of water quality and biota downstream of these outfalls suggest that discharges from these facilities have not

**Table 5-1.** Estimated average annual cumulative radiological doses and resulting health effects to offsite population from liquid releases.

Activity	Offsite population			
	Maximally exposed individual		50-mile population	
	Dose <sup>a</sup>	Fatal cancer risk <sup>b</sup>	Collective dose <sup>c</sup>	Latent cancer fatalities <sup>d</sup>
Accelerator Production of Tritium	6.3×10 <sup>-6</sup>	3.2×10 <sup>-9</sup>	0.14	7.0×10 <sup>-5</sup>
Tritium Extraction Facility <sup>e</sup>	0	0	0	0
Waste Management <sup>f</sup>	6.9×10 <sup>-7</sup>	3.5×10 <sup>-10</sup>	0.0068	3.4×10 <sup>-6</sup>
Defense Waste Processing Facility <sup>g</sup>	0	0	0	0
Plant Vogtle <sup>h</sup>	5.4×10 <sup>-5</sup>	2.7×10 <sup>-8</sup>	0.0025	1.3×10 <sup>-6</sup>
Surplus HEU disposition <sup>i</sup>	0	0	0	0
Tritium supply and recycling <sup>j</sup>	7.7×10 <sup>-5</sup>	3.9×10 <sup>-8</sup>	10	5.0×10 <sup>-3</sup>
Interim Management of Nuclear Materials <sup>k</sup>	1.6×10 <sup>-4</sup>	8.0×10 <sup>-8</sup>	0.65	3.3×10 <sup>-4</sup>
River Water System <sup>l</sup>	1.4×10 <sup>-8</sup>	7.0×10 <sup>-12</sup>	3.5×10 <sup>-5</sup>	1.8×10 <sup>-8</sup>
Management of Spent Nuclear Fuel <sup>m</sup>	5.7×10 <sup>-5</sup>	2.9×10 <sup>-8</sup>	0.19	9.5×10 <sup>-5</sup>
1995 SRS practices <sup>n</sup>	1.4×10 <sup>-4</sup>	7.0×10 <sup>-8</sup>	1.7	8.5×10 <sup>-4</sup>
<b>Total</b>	<b>5.0×10<sup>-4</sup></b>	<b>2.1×10<sup>-7</sup></b>	<b>13</b>	<b>6.3×10<sup>-3</sup></b>

a. Dose in rem.

b. Probability of fatal cancer.

c. Dose in person-rem.

d. Incidence of excess fatal cancers.

e. Source: DOE (1995d).

f. Source: DOE (1995a).

g. Source: DOE (1994a).

h. Source: NRC (1996).

i. Source: DOE (1996); HEU = highly enriched uranium.

j. Source: DOE (1995b); population dose is in 2030.

k. Source: DOE (1995c).

l. Source: DOE (1997).

m. Source: Arnett and Mamatey (1996).

n. Source: Young (1997), maximum of options.

degraded the water quality of Upper Three Runs (Wike et al. 1994). Depending on the volumes of radioactive, hazardous, and mixed wastes generated during environmental restoration and decontamination and decommissioning of surplus facilities, a number of additional waste management facilities could be built that would also directly or indirectly discharge into Upper Three Runs (DOE 1995a). Sanitary and process wastewater discharges from these facilities would be subject to NPDES permit effluent limitations designed to protect water quality and aquatic life in Upper Three Runs. Were the APT facility to be built, its sanitary and process wastewater discharges would likewise be required to meet NPDES permit limits that are known to be protective of water quality and wildlife.

## 5.2 Air Resources

Table 5-2 compares the cumulative concentrations of nonradiological air pollutants from the SRS to Federal and state regulatory standards. The listed values are the maximum modeled concentrations that could occur at ground level at the Site boundary. The data demonstrate that total estimated concentrations of nonradiological air pollutants from the SRS, including the contributions from APT, would be below the regulatory standards at the Site boundary. The highest percentages of the regulatory standards are for sulfur dioxide concentrations for the shorter time interval estimates.

Table 5-2. Estimated maximum nonradiological cumulative ground-level concentrations of criteria and toxic pollutants (micrograms per cubic meter) at SRS boundary.<sup>a,b</sup>

Pollutant	Averaging time	Regulatory standard	Other SRS sources <sup>c</sup>	APT preferred	Percent of standard
Carbon monoxide	1 hour	40,000	3,600	6.1	9.1
	8 hours	10,000	860	0.76	8.6
Nitrogen oxides	Annual	100	36	0.0091	36
Sulfur dioxide	3 hours	1,300	1,200	0.13	94
	24 hours	365	360	0.016	98
	Annual	80	18	0.00014	23
Total Suspended Particles	Annual	75	22	0.00057	29
Particulate Matter (≤ 10 microns)	24 hours	150	110	0.016	76
	Annual	50	25	0.0003	50

a. Sources: DOE (1995a,b,c; 1996; 1997). Young 1997, Hunter and Stewart 1994.

b. The Tritium Extraction Facility would add annually 1,800 pounds of carbon monoxide, 4,900 pounds of nitrogen oxide, and 64 pounds of sulfur dioxide to the cumulative concentration of nonradiological pollutants.

c. All SRS sources including spent nuclear fuel management, SRS waste management activities, tritium supply and recycling, disposition of surplus highly enriched uranium, interim management of nuclear materials, and SRS baseline emissions.

DOE also evaluated the cumulative impacts of airborne radioactive releases in terms of dose to a maximally exposed individual at the SRS boundary. Table 5-3 lists the results of this analysis, using 1995 emissions (1992 for Plant Vogtle) as the SRS baseline. The cumulative dose to the maximally exposed member of the public would be 0.0027 rem (or 2.7 millirem) per year, or about 27 percent of the regulatory standard of 10 millirem per year (40 CFR Part 61). Summing the doses to maximally exposed individuals for the 10 actions and baseline SRS operations listed in Table 5-3 is an extremely conservative approach because it assumes that the maximally exposed individuals would occupy the same location over the same time period, which is a physical impossibility.

Adding the population doses from current and projected SRS activities, operation of the Defense Waste Processing Facility, tritium supply and recycling, and management of spent nuclear fuel could yield a total annual cumulative dose of 200 person-rem from airborne sources. The total annual cumulative dose translates into 0.10 latent cancer fatality for each year of exposure for the 620,000-person population living within a 50-mile radius of the SRS. These data dem-

onstrate that the addition of air emissions from APT does not significantly affect airborne levels of toxic pollutants or radioactive material.

### 5.3 Waste Generation

Table 5-4 lists cumulative volumes of high-level, low-level, transuranic, hazardous, and mixed wastes that the SRS would generate. The values are based on the SRS 30-year expected waste forecast (WSRC 1994) which includes tritium recycling waste. It also lists waste forecasts for the APT Preferred alternative. The 30-year waste forecast is based on operations waste forecast from existing generators and the following assumptions: secondary waste from the Defense Waste Processing Facility, In-Tank Precipitation, and Extended Sludge Processing operations addressed in the DWPF EIS (DOE 1994a); high-level waste volumes based on the selected option for the F-Canyon Plutonium Solutions EIS (DOE 1994b) and the Interim Management of Nuclear Materials at SRS EIS (DOE 1995c); some investigation-derived wastes handled as hazardous waste in compliance with the Resource Conservation and Recovery Act; purge water from well sampling

Table 5-3. Estimated average annual cumulative radiological doses and resulting health effects to offsite population from airborne releases.

Activity	Offsite population			
	Maximally exposed individual		50-mile population	
	Dose <sup>a</sup>	Fatal cancer risk <sup>b</sup>	Collective dose <sup>c</sup>	Latent cancer fatalities <sup>d</sup>
Accelerator Production of Tritium	3.6×10 <sup>-5</sup>	1.8×10 <sup>-8</sup>	1.2	6.0×10 <sup>-4</sup>
Tritium Extraction Facility <sup>e</sup>	8.1×10 <sup>-6</sup>	4.1×10 <sup>-9</sup>	0.39	1.9×10 <sup>-4</sup>
Waste Management <sup>f</sup>	3.2×10 <sup>-5</sup>	1.6×10 <sup>-8</sup>	1.5	7.5×10 <sup>-4</sup>
Defense Waste Processing Facility <sup>g</sup>	1.0×10 <sup>-6</sup>	5.0×10 <sup>-10</sup>	0.071	3.5×10 <sup>-6</sup>
Plant Vogtle <sup>h</sup>	2.5×10 <sup>-6</sup>	1.3×10 <sup>-9</sup>	0.042	2.1×10 <sup>-5</sup>
Surplus HEU disposition <sup>i</sup>	2.0×10 <sup>-5</sup>	1.0×10 <sup>-8</sup>	1.3	6.3×10 <sup>-4</sup>
Tritium supply and recycling <sup>j</sup>	0.0020	1.0×10 <sup>-6</sup>	170	0.085
Interim Management of Nuclear Materials <sup>k</sup>	5.4×10 <sup>-4</sup>	2.7×10 <sup>-7</sup>	22	0.011
River Water System <sup>l</sup>	6.9×10 <sup>-6</sup>	3.5×10 <sup>-9</sup>	0.0027	1.4×10 <sup>-6</sup>
Management of Spent Nuclear Fuel <sup>n</sup>	1.5×10 <sup>-5</sup>	7.5×10 <sup>-9</sup>	0.56	2.8×10 <sup>-4</sup>
1995 SRS activities <sup>m</sup>	6.0×10 <sup>-5</sup>	3.0×10 <sup>-8</sup>	3.5	0.0018
<b>Total</b>	<b>0.0027</b>	<b>1.4×10<sup>-6</sup></b>	<b>200</b>	<b>0.10</b>

- |   |   |
|---|---|
| a. Dose in rem.                             | h. Source: NRC (1996).                                |
| b. Probability of fatal cancer.             | i. Source: DOE (1996); HEU = highly enriched uranium. |
| c. Dose in person-rem.                      | j. Source: DOE (1995b); population dose is for 2030.  |
| d. Incidence of excess fatal cancers.       | k. Source: DOE (1995c).                               |
| e. Source: DOE (1995d) and Simpkins (1997). | l. Source: DOE (1997).                                |
| f. Source: DOE (1995a).                     | m. Source: Amett and Mamatey(1996).                   |
| g. Source: DOE (1994a).                     | n. Source: Young (1997), maximum of options.          |

Table 5-4. Estimated cumulative waste generation from SRS operations (cubic meters).<sup>a,b</sup>

Waste type	SRS operations activities <sup>c</sup>	APT volume <sup>d</sup>
High-level <sup>e</sup>	150,750	0
Low-level <sup>f</sup>	344,062	42,075
Hazardous/mixed <sup>g</sup>	90,453	360
Transuranic	18,090	0
<b>Total</b>	<b>603,355</b>	<b>42,435</b>

- a. Sources: WSRC (1994a); Hess (1995); DOE (1995d).
- b. Based on a total 30-year expected forecast (excluding Environmental Restoration and Decontamination and Decommissioning activities).
- c. Includes spent nuclear fuel management, Defense Waste Processing Facility, stabilization of plutonium solutions in F-Canyon, HB-Line operations, tritium supply and recycling, tritium extraction facility, and Naval Reactors Program waste.
- d. Values based on estimated annual waste quantities for the Preferred alternative (multiplied by 30).
- e. The SRS operations estimate includes 131,000 cubic meters of liquid high-level waste currently in storage at F- and H-Tank farms.
- f. Quantity includes high concentration waste.
- g. Quantity includes high concentration mixed waste.

handled as hazardous waste; and continued receipt of small amounts of low-level waste from other DOE facilities and Naval nuclear operations. Waste generated from decontamination and decommissioning and planned environmental restoration projects are not included in the operations waste forecast. The estimated quantity of waste from operations in this forecast during the next 30 years would be 600,000 cubic meters. In addition, waste associated with environmental restoration and decontamination and decommissioning activities would have a 30-year expected forecast of 710,000 cubic meters (WSRC 1994; Hess 1995). Therefore, the total amount of waste from SRS activities (exclusive of APT operation) is estimated to be approximately 1,300,000 cubic meters.

As stated in Section 4.1.7.1, low-level waste would be generated from APT maintenance, radiological surveys, and production activities, and mixed and hazardous waste would be generated from APT maintenance activities. DOE does not expect these activities to generate high-level and transuranic waste. The total 30-year waste volume associated with APT activities would be 42,000 cubic meters.

The Three Rivers Solid Waste Authority Regional Waste Management Center at the Savannah River Site is being built for the disposal of non-hazardous and non-radioactive solid wastes from the SRS and eight surrounding South Carolina counties. This municipal solid waste landfill is intended to provide state of the art (Subtitle D) facilities for landfilling solid wastes while reducing the environmental consequences associated with construction and operation of multiple county-level facilities (DOE 1995e). It was designed to accommodate combined SRS and county solid waste disposal needs for at least 20 years, with a projected maximum operational life of 45 to 60 years (DOE 1995e). The landfill is designed to handle an average of 1,000 tons per day and a maximum of 2,000 tons per day of municipal solid wastes. The SRS and eight cooperating counties had a combined generation rate of 900 tons per day in 1995. The Three Rivers Solid Waste Authority

Regional Waste Management Center is scheduled to open in mid-1998.

The APT would not generate large volumes of radioactive, hazardous, or solid wastes and would have very little impact on existing capacities of SRS waste storage and/or management facilities.

## 5.4 Utilities and Energy

Table 5-5 lists the cumulative consumption of electricity from activities at the SRS. The values are based on annual consumption estimates. Of the SRS activities, accelerator production of tritium would place the largest demand on electricity resources. The estimated annual electricity use would be 3,100,000 megawatt-hours, as discussed in Section 4.1.4. This would be a significant increase in cumulative electricity usage at SRS.

Under the Preferred alternative, to acquire electricity from existing capacity and through market transactions, DOE estimates the potential impacts of supplying the APT load through a representative mix of generation types (see Section 4.4). Because the actual impacts would be dispersed and the actual location of the electricity generation is unknown, DOE cannot estimate impacts in a meaningful, site-specific way.

The estimated amount of water needed to operate the APT facilities in the Preferred alternative would be about 3.2 billion gallons per year, most of which would be nonpotable water used for makeup water for the mechanical-draft cooling tower. In the Preferred alternative, makeup water would be piped from the Savannah River using the River Water system.

At present, only one Savannah River pump-house (3G) and one small river water pump (installed in 1997) are in use, withdrawing 5,000 gallons per minute (2.6 billion gallons per year) of water from the Savannah River for SRS industrial facilities. If the Mechanical-Draft Cooling Tower with River Water Makeup alternative is implemented, an additional 6,000 gal-

Table 5-5. Estimated average annual cumulative electrical consumption.

Activity	Electricity consumption (megawatt-hours)
Accelerator Production of Tritium	3,100,000
Tritium Extraction Facility <sup>a</sup>	4,500
Defense Waste Processing Facility <sup>b</sup>	32,000
Surplus HEU disposition <sup>c</sup>	5,000
Tritium supply and recycling <sup>d</sup>	24,000
Interim Management of Nuclear Materials <sup>e</sup>	140,000
Waste Management	N/A <sup>f</sup>
River Water System Shutdown <sup>g</sup>	2,500
1993 SRS usage <sup>h</sup>	660,000
Management of Spent Nuclear Fuel <sup>i</sup>	24,000
<b>Total</b>	<b>4,000,000</b>

- a. Source: DOE (1995d).  
 b. Source: DOE (1994a).  
 c. Source: DOE (1996); HEU = highly enriched uranium.  
 d. Source: DOE (1995b); includes recycling upgrades only.  
 e. Source: DOE (1995c).

- f. Not available in Waste Management EIS.  
 g. Source: DOE (1997a).  
 h. Source: DOE (1995e).  
 i. Source: Young (1997).

lons per minute of Savannah River water would be pumped to APT facilities for cooling. If the SRS is one of the four DOE sites chosen for the "blending down" of highly-enriched uranium (HEU) to low-enriched uranium (LEU), approximately 5 million gallons per year of surface water would be required (DOE 1996). Thus, the total projected surface (river) water withdrawal over the projected APT operating period would be about 11,000 gallons per minute ( $5.8 \times 10^9$  gallons per year), which would equal approximately 3 percent of the river water withdrawn (380,000 gallons per minute) in 1988 when a full complement of SRS reactors last operated and less than one percent of the average Savannah River flow at the Site of 10,000 cubic feet per second (or  $2.4 \times 10^{12}$  gallons per year).

For purposes of comparison, DOE also examined the cumulative impact of withdrawing 6,000 gallons per minute of groundwater for cooling tower makeup. The current rate of groundwater withdrawal for all uses (process water, cooling, drinking water) at the SRS is estimated to be 9 to 12 million gallons per day (see Section 4.1.1). If groundwater were used to

supply makeup water for APT cooling towers, an additional 8.6 million gallons per day of groundwater would be required. Spent nuclear fuel management activities over the years 1998-2035 would require a small amount of groundwater, from 13,000 to 150,000 gallons per day, depending on the management option chosen (Young 1997). An additional 2.5 million gallons of groundwater could be required annually for operation of a stand-alone Tritium Extraction Facility (DOE 1995d). Thus, sitewide groundwater withdrawals over the projected APT operating period would range from about 18 to 21 million gallons per day if groundwater is used to supply makeup water to APT cooling towers. This could exceed the estimated 16 to 25 million gallon-per-day production capacity of the aquifer.

The total groundwater withdrawal for county and municipal water systems in the six-county region of influence (ROI) is approximately 63 million gallons per day, compared to an estimated regional capacity of 167 million gallons per day (HNUS 1997). This suggests that regional aquifers can accommodate additional demand, although there are almost certainly

aquifers and areas within aquifers that are at or near their production capacity. It should be noted that the 63 million gallon per day withdrawal rate does not include shallow domestic wells, nor does it include any wells for process or potable water at industrial facilities in the six-county area, thus it slightly underestimates total groundwater withdrawals in the ROI.

## 5.5 Public and Worker Health

Table 5-6 summarizes the cumulative radiological health effects of routine SRS operations based on 1995 data and proposed DOE actions. The EISs listed in this table describe the impacts resulting from proposed DOE actions. In addition to estimated radiological doses to the hypothetical maximally exposed individual and the offsite population, Table 5-6 lists potential latent cancer fatalities for the public and workers due to exposure to radiation. These data demonstrate that operation of APT will minimally increase cumulative radiation doses to the public and onsite workers.

## 5.6 Ecological Resources

Building the APT facility would require clearing and grading a 250 acre forested site. Although the preferred site contains no unique flora and fauna and no sensitive or critical ecological habitats, it does provide feeding, foraging, roosting, breeding, nesting, and denning habitat for a variety of reptiles, birds, and mammals. Several other actions currently being carried out or proposed by DOE could result in loss of undeveloped, largely-forested land. Waste management activities at the SRS are expected to require the clearing of 107-940 additional acres of undeveloped land by the year 2008, depending on the volumes of radioactive, hazardous, and mixed wastes generated by on-going operations, environmental restoration, and decontamination and decommissioning of surplus facilities (DOE 1995a). The Three Rivers Solid Waste Authority Regional Waste Management Center, which includes a large landfill for non-hazardous municipal and solid wastes, is currently being built between B- and D-Areas on a

ridge overlooking Upper Three Runs. The initial land clearing for the landfill will involve 500 forested acres, with an additional 60 acres to be cleared every 5 years for approximately 30 years (DOE 1995e).

On May 22, 1997 DOE announced (62 FR 28009) its intent to prepare an Environmental Impact Statement on the disposition of the United States' weapons-usable surplus plutonium. This EIS is tiered from the *Storage and Disposition of Weapons-Usable Fissile Materials Programmatic EIS*, for which a Record of Decision (62 FR 3014) was issued on January 14, 1997. Three types of plutonium-management facilities could be built at the SRS: (1) a facility to disassemble and convert pits into plutonium oxide suitable for disposition, (2) a facility to immobilize surplus plutonium in a glass or ceramic form for disposition in a geologic repository, and (3) a facility to fabricate plutonium oxide into mixed oxide fuel. Any of these facilities could have an impact on SRS resources; however, should any or all of these facilities be located at SRS they would likely be built in previously disturbed or industrialized areas (62 FR 28009).

Thus, if all reasonably-foreseeable actions currently being considered by DOE were to be implemented, 1,000-1,800 acres of undeveloped SRS land could be converted to industrial uses by the year 2008. This represents 0.6 to 1.0 percent of the 180,000 acres of undeveloped swamp- and forestland that currently exists on the Site. The loss of 1,000-1,800 acres of undeveloped and forested land could result in reduced diversity and abundance of animal species that require large, unbroken tracts of forestland. However, given the fact that this acreage represents a small portion of the available undeveloped land on the site, any cumulative reductions in diversity and abundance of forest-dependent animals would be small. It should be noted that under the Preferred alternative the APT facility would be built in the same general area, a 45 square mile rectangle in the center of the (310 square mile) Site, that contains all five reactor areas, Central Stores,

**Table 5-6. Estimated average annual cumulative radiological doses and resulting health effects to offsite population and facility workers.**

Activity	Maximally exposed individual				Offsite population <sup>a</sup>				Workers	
	Dose from airborne releases <sup>b</sup>	Dose from liquid releases <sup>b</sup>	Total Dose <sup>b</sup>	Fatal Cancer risk <sup>c</sup>	Collective dose from airborne releases <sup>d</sup>	Collective dose from liquid releases <sup>d</sup>	Total collective dose <sup>d</sup>	Latent cancer fatalities <sup>e</sup>	Collective dose <sup>d</sup>	Latent cancer fatalities <sup>e</sup>
Management of Spent Nuclear Fuels <sup>f</sup>	1.5×10 <sup>-5</sup>	5.7×10 <sup>-5</sup>	7.2×10 <sup>-5</sup>	3.6×10 <sup>-8</sup>	0.56	0.19	0.75	3.8×10 <sup>-4</sup>	55	0.022
Waste Management <sup>g</sup>	3.2×10 <sup>-5</sup>	6.9×10 <sup>-7</sup>	3.3×10 <sup>-5</sup>	1.6×10 <sup>-8</sup>	1.5	0.0068	1.5	7.5×10 <sup>-4</sup>	81	0.032
Defense Waste Processing Facility <sup>h</sup>	1.0×10 <sup>-6</sup>	0	1.0×10 <sup>-6</sup>	5.0×10 <sup>-10</sup>	0.071	0	0.071	3.5×10 <sup>-5</sup>	120	0.047
Surplus HEU Disposition <sup>i</sup>	2.0×10 <sup>-5</sup>	0	2.0×10 <sup>-5</sup>	1.0×10 <sup>-8</sup>	1.3	0	1.3	6.3×10 <sup>-4</sup>	89	0.036
Tritium Supply and Recycling <sup>j</sup>	2.0×10 <sup>-3</sup>	7.7×10 <sup>-5</sup>	2.1×10 <sup>-3</sup>	1.0×10 <sup>-6</sup>	170	10	180	0.09	1.6	6.4×10 <sup>-4</sup>
Interim Mgmt of Nuclear Materials <sup>k</sup>	5.4×10 <sup>-4</sup>	1.6×10 <sup>-5</sup>	5.6×10 <sup>-4</sup>	2.8×10 <sup>-5</sup>	22	0.065	22	0.011	140	0.056
River Water System <sup>l</sup>	6.9×10 <sup>-6</sup>	1.4×10 <sup>-8</sup>	6.9×10 <sup>-6</sup>	3.5×10 <sup>-9</sup>	0.0027	3.5×10 <sup>-5</sup>	0.0027	1.4×10 <sup>-6</sup>	0.029	1.2×10 <sup>-5</sup>
Plant Vogtle <sup>m</sup>	2.5×10 <sup>-6</sup>	5.4×10 <sup>-5</sup>	5.7×10 <sup>-5</sup>	2.8×10 <sup>-8</sup>	0.042	0.0025	0.045	2.3×10 <sup>-5</sup>	NA	NA
1995 SRS Activities <sup>n</sup>	6.0×10 <sup>-5</sup>	1.4×10 <sup>-4</sup>	2.0×10 <sup>-4</sup>	1.0×10 <sup>-7</sup>	3.5	1.7	5.2	0.0026	250	0.10
Tritium Extraction Facility <sup>o</sup>	8.1×10 <sup>-6</sup>	0	8.1×10 <sup>-6</sup>	4.1×10 <sup>-9</sup>	0.39	0	0.39	1.9×10 <sup>-4</sup>	0.28	1.1×10 <sup>-4</sup>
Accelerator Production of Tritium	3.6×10 <sup>-5</sup>	6.3×10 <sup>-6</sup>	4.2×10 <sup>-5</sup>	2.1×10 <sup>-8</sup>	1.2	0.14	1.3	6.7×10 <sup>-4</sup>	88	4.4×10 <sup>-2</sup>
Total	0.0027	3.5×10 <sup>-4</sup>	3.1×10 <sup>-3</sup>	1.5×10 <sup>-6</sup>	200	12	210	0.11	830	0.33

a. Collective dose to the 50-mile (80-kilometer) population for atmospheric releases and to the downstream users of the Savannah River for liquid releases.

b. Dose in rem.

c. Probability of fatal cancer.

d. Dose in person-rem.

e. Incidence of excess fatal cancers.

f. Source: Maximum of options Young (1997).

g. Source: DOE (1995a).

h. Source: DOE (1994a).

i. Source: DOE (1996); HEU = highly enriched uranium.

j. Source: DOE (1995b) Tritium Supply and Recycling data include recycling upgrade impacts only.

k. Source: DOE (1995c).

l. Source: DOE (1997).

m. Source: NRC (1996).

n. Source: Arnett and Mamatey (1996).

o. Source: DOE (1995d) and Simpkins (1997).



and F- and H-Areas. This should serve to mitigate the site-wide effect of land clearing on reptiles, birds, and small mammals because substantial portions of this central area are already developed. Siting additional facilities in this industrialized central area would minimize the cumulative effect of forest destruction and forest fragmentation on local and regional biodiversity. Section 4.2.2 discusses impacts associated with displacement of animals, including increased intraspecific and interspecific competition, reduced reproduction, animal-vehicle collisions, and loss of young animals to predators.

## 5.7 Socioeconomics

Table 5-7 summarizes the estimated cumulative regional economic and population changes from construction and operation of the APT facility (Preferred alternative), a potential \$200 million Treatment and Storage Facility that DOE could build at the SRS to manage spent nuclear fuel (Young 1997), and the construction and operation in Aiken County of a \$435 million tire fac-

tory recently announced by Bridgestone-Firestone, Inc., which will employ 800 when fully operational.

During the construction period, average annual rates of growth for the five economic and population measures (Table 5-7) are less than during the 4-year historical period discussed in Section 4.3.2.1. The average annual growth rates during the construction period for these projects are 0.47%, 0.7%, and 1.62% for employment, population, and total personal income, respectively. The growth rates for GRP and state and local government expenditures are 1.21% and 1.9%. Potential impacts to the regional construction industry would be less than discussed in Section 4.4.2.6 for the coal-fired electricity generating plant, as the tire factory will be completed and operational before the SRS construction work force reaches its peak. During the operational phase of the APT facility, the growth rates for these measures would be less than the historical rates. There would be no significant cumulative socioeconomic impacts from construction or operation of the APT.

**Table 5-7. Cumulative economic and population measure.<sup>a</sup>**

Year	Total employment	Population	Personal income <sup>b</sup>	Gross regional product <sup>b</sup>	State and local government expenditures <sup>b</sup>
1	93	26	2.8	4.4	0.0
2	1,422	447	43.5	74.5	1.3
3	3,191	1,489	99.6	181.7	4.6
4	4,442	2,931	1,43.1	275.2	9.2
5	3,756	4,036	1,27.6	249.7	12.8
6	3,507	4,758	1,25.4	246.5	15.4
7	3,250	5,292	1,22.2	242.1	17.3
8	2,856	5,613	1,14.4	234.5	18.7
9	2,479	5,752	1,06.8	237.4	19.3
10	2,215	5,761	1,02.0	244.8	19.6
11	2,038	5,672	97.7	244.0	19.5
12	2,038	5,554	97.9	247.3	19.2
13	2,045	5,449	98.6	250.3	19.0
14	2,092	5,370	100.8	257.3	19.0
15	2,137	5,318	103.1	264.1	18.9
16	2,178	5,276	105.1	270.7	18.9
17	2,222	5,245	107.4	277.6	19.0
18	2,267	5,224	109.9	284.9	19.0
19	2,306	5,208	112.4	291.8	19.0
20	2,342	5,193	114.7	298.7	19.0
21	2,379	5,184	117.3	306.1	19.1
22	2,410	5,180	119.1	313.4	19.2
23	2,444	5,183	121.3	321.4	19.3
24	2,474	5,196	123.3	329.4	19.3
25	2,500	5,219	125.4	337.3	19.6
26	2,525	5,253	127.6	345.2	19.9
27	2,546	5,298	129.7	353.0	20.1
28	2,566	5,354	131.9	360.9	20.4
29	2,585	5,420	134.1	368.5	20.7
30	2,603	5,495	136.4	376.4	21.1
31	2,621	5,578	139.0	384.5	21.6
32	2,639	5,667	141.6	392.8	22.0
33	2,656	5,758	144.2	401.0	22.5
34	2,675	5,851	147.0	409.5	22.9
35	2,698	5,949	150.3	418.1	23.6
36	2,722	6,053	154.0	427.3	24.3
37	2,747	6,159	157.9	436.6	24.9
38	2,773	6,267	161.8	446.1	25.4
39	2,800	6,373	165.9	455.8	26.1

a. Source: REMI (1996).

b. All dollar amounts are millions of 1996 dollars.

---

## References

- Arnett, M. W. and A. R. Mamatey, 1996, *Savannah River Site Environmental Data for 1995*, WSRC-TR-96-075, Savannah River Site, Aiken, South Carolina.
- DOE (U.S. Department of Energy), 1994a, *Final Defense Waste Processing Facility Supplemental Environmental Impact Statement*, DOE/EIS 0082-S, Savannah River Operations Office, Aiken, South Carolina.
- DOE (U.S. Department of Energy), 1994b, *Final F-Canyon Plutonium Solutions Environmental Impact Statement*, DOE/EIS-0219, Savannah River Operations Office, Aiken, South Carolina.
- DOE (U.S. Department of Energy), 1995a, *Savannah River Site Waste Management Final Environmental Impact Statement*, DOE/EIS-0217, Savannah River Operations Office, Aiken, South Carolina.
- DOE (U.S. Department of Energy), 1995b, *Final Programmatic Environmental Impact Statement for Tritium Supply and Recycling*, DOE/EIS-0161, Office of Reconfiguration, Washington, D.C.
- DOE (U.S. Department of Energy), 1995c, *Final Environmental Impact Statement - Interim Management of Nuclear Materials*, Savannah River Operations Office, Aiken, South Carolina.
- DOE (U.S. Department of Energy), 1995d, *Data Report on Tritium Extraction Facility for Commercial Light Water Reactor*, Office of Reconfiguration, Washington, D.C.
- DOE (U.S. Department of Energy), 1995e, *Environmental Assessment for the Construction and Operation of the Three Rivers Solid Waste Authority Regional Waste Management Center at the Savannah River Site*, DOE/EA-1079, U.S. Department of Energy Savannah River Operations Office, Savannah River Site.
- DOE (U.S. Department of Energy), 1996, *Disposition of Surplus Highly Enriched Uranium Final Environmental Impact Statement*, DOE/EIS-0161, Office of Fissile Materials Disposition, Washington, D.C.
- DOE (U.S. Department of Energy), 1997, *Final Environmental Impact Statement, Shutdown of the River Water System at the Savannah River Site*, DOE/EIS-0268, Savannah River Operations Office, Aiken, South Carolina.
- Hess, M. L., 1995, "WSRC Data Transmittal - Summary of Changes Between Draft and Final WMEIS Forecasts and Alternatives," ESH-NEP-95-0084, memorandum to H. L. Pope, (U.S. Department of Energy, Savannah River Operations Office) Westinghouse Savannah River Company, Aiken, South Carolina.
- HNUS (Halliburton NUS Corporation), 1997, *Socioeconomic Characteristics of Selected Counties and Communities Adjacent to the Savannah River Site*, prepared for U.S. Department of Energy Savannah River Operations Office, Aiken, South Carolina.
- Hunter, C. H. and J. Stewart, 1994, *Air Quality Calculations for DWPF Supplemental Environmental Impact Statement*, SRT-ETS-940891, Westinghouse Savannah River Company, Savannah River Site, Aiken, South Carolina.
- NRC (U.S. Nuclear Regulatory Commission), 1996, *Dose Commitments Due to Radioactive Releases from Nuclear Power Plant Sites in 1992*, NUREG/CR 2850, Vol. 14, Washington, D.C.

- REMI, 1996, *Economic Demographic Forecasting and Simulation 53-Sector Model*, Regional Economic Model, Inc., Amherst, Massachusetts.
- SCDHEC (South Carolina Department of Health and Environmental Control), 1992, *South Carolina Nuclear Facility Monitoring - Annual Report 1992*, Columbia, South Carolina.
- Simpkins, A. A., 1997, Westinghouse Savannah River Company, Aiken, South Carolina, interoffice memorandum to C. B. Shedrow, APT EIS Routine Release Environmental Dosimetry Calculations - TEF Emissions, SRT-EST-97-400, August 15.
- Wike, L. O., R. W. Shipley, A. L. Bryan, Jr., J. A. Bowers, C. L. Cunningham, R. R. del Carmen, G. P. Friday, J. E. Irwin, J. J. Mayer, E. A. Nelson, M. H. Paller, V. A. Rogers, W. L. Specht, and E. Wilde, 1994, *SRS Ecology: Environmental Information Document*, WSRC-TR-93-496, Westinghouse Savannah River Company, Aiken, South Carolina.
- WSRC (Westinghouse Savannah River Company), 1994, *Thirty-Year Solid Waste Generation Forecast for Facilities at SRS*, Revision 3, Volume I, WSRC-RP-94-532, Savannah River Site, Aiken, South Carolina.
- Young, P. L., 1997, Halliburton NUS, Aiken, South Carolina, interoffice memorandum to W. J. Craig, Preliminary Environmental Impact Data for the SRS Spent Nuclear Fuel Management EIS, September 26.

# Chapter 6

## Resource Commitments

---

---

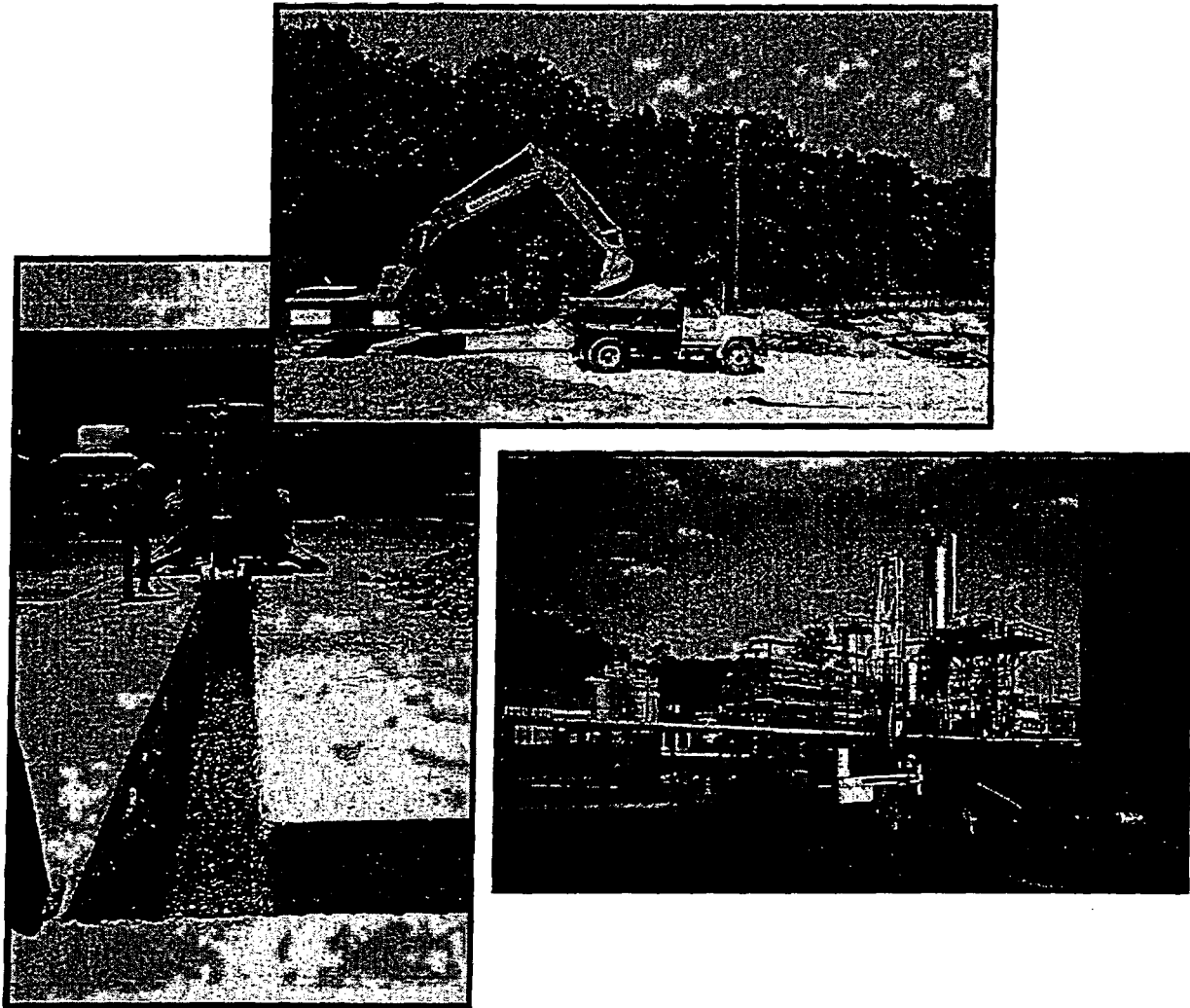

The construction and operation of the APT would result in the consumption of resources. In some cases, the impacts would be unavoidable and irreversible. In other cases, the impacts would be short-term and reversible. For example, some consumable resources could be recycled and following the operational life of the facility, DOE could remove some of the infrastructure and return to previous conditions. Waste minimization and pollution prevention programs are inherent elements of the APT project.

## CHAPTER 6. RESOURCE COMMITMENTS

This chapter describes impacts of the construction and operation of an accelerator for the production of tritium on the resource commitments in terms of unavoidable adverse impacts, short-term uses versus long-term productivity, and irreversible or irretrievable commitments of resources. The chapter also discusses waste minimization, pollution prevention, and energy conservation. This information is based on the discussions in Chapter 4.

### 6.1 Unavoidable Adverse Impacts

Current operations at the SRS withdraw approximately 5,000 gallons per minute of water from the Savannah River for the maintenance of L-Lake water levels, auxiliary equipment cooling, fire protection, and sanitary wastewater in K-, L-, and P-Areas. The implementation of the preferred cooling water alternative (Mechanical-Draft Cooling Towers with River Water Makeup) would result in negligible impacts to ecological resources and water use. If DOE selected the preferred cooling water alternative, river water withdrawals would increase from current levels of 5,000 to 11,000 gallons per minute. Similar increases in water use would occur for the K-Area Cooling Tower (natural-draft) alternative. However, implementation of the Once-Through Cooling Water alternative would result in significantly greater increases in water use and ecological impacts, as described in Chapter 4.

Heated water discharges from the Once-Through Cooling Water alternative would raise the temperatures in Ponds 2, 5, and C an average of 18°F above their average seasonal temperatures, resulting in potential adverse impacts to the aquatic community (benthic organisms and fish). The implementation of either the Mechanical-Draft or the K-Area Cooling Tower alternative would result in fewer impacts, as described in Chapter 4.

The implementation of the Once-Through Cooling Water alternative would result in estimated annual entrainment losses of 3.4 million fish eggs and 6.4 million fish larvae and impingement losses of about 2,600 fish annually. The implementation of either the Mechanical-

Draft or the K-Area Cooling Tower alternative would result in fewer impacts, as described in Chapter 4.

Every alternative for APT operation would affect wetlands because of cooling water discharges (see Section 4.2.2.3 Wetland Ecology). The greatest impacts would occur with the operation of the Once-Through Cooling Water alternative; these impacts from thermal stress would be more pronounced in Pond 2 and less in Ponds 5 and C and Par Pond. That alternative would cause additional loss of wetlands due to increased flows and subsequent raising of the water levels. The Preferred alternative of mechanical-draft cooling towers using river water as makeup would have the least adverse impact on wetlands and the slight warming provided during the cooler months could provide positive wetland impacts.

Unavoidable radiation exposures, which include increased occupational exposures and exposures to the general public from normal accelerator operation, and possible remobilization of radioactive Cesium already in the sediments at outfall locations due to increased water flow would be well below regulatory limits.

### 6.2 Short-Term Uses Versus Long-Term Productivity

The current uses of the preferred and alternate APT sites is timber production. The proposed action would commit as much as 250 acres to a single use for an indefinite period, possibly forever. Not all of the area would receive immediate impacts, but over the 10-year construction period the entire area would be deforested and the timber would be removed. In addition, the

implementation of the Preferred alternative would result in the commitment of electric (0.5 mile), rail (3.8 miles), road (8 miles), pipeline (8.1 miles), and sewer (3 miles) corridors for the life of the project. The width of the corridors could vary from 12 to 150 feet, resulting in the commitment of approximately 30 acres to infrastructure corridors for the accelerator.

In addition to the 250 acres identified above, construction of the APT would result in the construction of two temporary facilities: concrete batch plants and a construction debris landfill. The exact acreage for these facilities is unknown at this time; however, it is likely that additional acreage above the 250 acres could be required. Likewise, an expanded footprint required for the modular APT design option would require more land. At the end of the operational life of the temporary facilities, DOE would close or remove infrastructure in accordance with permit and regulatory requirements.

Following the operational life of the accelerator, DOE could remove some of the infrastructure corridors and decontaminate and decommission the accelerator under appropriate regulatory requirements. DOE would perform additional NEPA reviews for these activities. At this time there is no proposal to remove the accelerator or its support structures.

The project-related short-term uses of the environment would include the following:

- Use of as many as 125,000 gallons per minute of water for 40 years from the Savannah River if DOE selects the Once-Through Cooling Water alternative. Other cooling water alternatives would use considerably less water (i.e., 6,000 gallons per minute).
- Increased vehicle traffic, noise, and air quality impacts from activities during the 10-year construction period.
- Operational activities resulting in increases in vehicle and rail traffic, noise, and air emissions from current levels and would

remain for the 40-year operational life of the project.

- Small increases in the amounts of radiological and nonradiological constituents discharged to National Pollutant Discharge Elimination System-permitted outfalls and ultimately to onsite streams.
- Addition of about 100 tons of sanitary solid waste during construction and 2,200 tons during the operational life of the project.
- Addition of 1,415 cubic meters of hazardous, mixed, and low-level radioactive waste to an approved disposal facility.

Short-term employment, expenditures, and tax revenues during the construction period would benefit the local economy. The longer-term operational workforce economic impacts, while positive, would be negligible. In addition, local governments could invest project-generated tax revenues in infrastructure and other services to provide for long-term economic and environmental productivity in the counties and cities.

In providing these economic, social, and environmental benefits, the project would enhance the long-term productivity and economic well-being of the states of Georgia and South Carolina in general, and the Central Savannah River Area in particular, and would not preclude the long-term use of much of the SRS for other missions. Mitigation of adverse environmental impacts would improve or enhance the long-term productivity of the Federal lands.

### 6.3 Irreversible And Irretrievable Resource Commitments

Resources that would be irreversibly and irretrievably committed during APT construction and operation include (1) materials that cannot be recovered or recycled and (2) materials consumed or reduced to unrecoverable forms. The National Environmental Policy Act requires an EIS to identify irreversible and irretrievable commitments of resources.



The land requirements for the construction and operation of the APT would represent an irreversible commitment because DOE probably would not remove the accelerator at the end of the proposed life span (40 years), and the land could not be restored to its original condition. The landforms created by the underground construction and above-ground berm probably would remain, and much of the land in the immediate area would not be available for other uses. However, much of the area outside the immediate area of the accelerator and support facilities could support other uses after closure.

The commitment of capital, labor, material, and energy during the construction and operation of the accelerator and support facilities would be irretrievable. Energy would be expended in the forms of diesel fuel, gasoline, and oil for construction equipment and vehicles, and as electricity, water, and raw materials for accelerator operation. Construction of the APT would generate nonhazardous, nonradioactive wastes, including sanitary solid wastes, construction debris (e.g., mixed rubble, metals, plastics), and sanitary wastewater.

Materials used for construction would include wood, aggregate, plastics, metals (steel, copper, aluminum, stainless steel), concrete, and small amounts of other materials. Waste generation estimates can be found in Section 4. Some of these materials (e.g., copper, stainless steel) could be salvaged when facilities are decontaminated and decommissioned (see Section 6.4). Table 6-1 lists estimated requirements of selected materials that would be consumed during construction and operation.

Required materials and chemicals for construction and operation would be readily available. No significant use of scarce or strategic material would be required for APT construction or operation.

In addition to the materials listed in Table 6-1, a DOE decision to construct and operate a new coal- or gas-fired electricity plant to meet APT needs under the 3 kilogram production scenario could result in the consumption of 2.5 million

tons of coal or 72 billion cubic feet of natural gas each year. Electrical usage under the 3 kilogram tritium production scenario would result in the use of 3.1 million megawatt-hours of electricity annually and under the 1.5 kilogram tritium production scenario a total of 1.6 million megawatt-hours annually would be used. Section 4.4 provides more detailed discussion on the impacts of supplying electricity to the APT.

**Table 6-1.** Estimated amounts of materials required for construction and operation of an accelerator at the Savannah River Site.

Material	Amount
Electricity	3.1 million megawatt-hours/year
Steel	65,000 tons
Concrete	260,000 cubic meters
Crushed stone	50,000 cubic meters
Asphalt	50,000 cubic meters
Diesel fuel	20,000 gallons/year
Water (potable)	5.6 million gallons/year
Water (nonpotable)	2.6 billion gallons/year

## 6.4 Waste Minimization, Pollution Prevention, and Energy Conservation

**Waste Minimization and Pollution Prevention.** DOE has instituted an aggressive waste minimization program which has produced substantial results. DOE's nuclear facilities have reduced the sizes of radiological control areas in order to reduce low-level radioactive waste. Other facilities have scrap metal segregation programs which reduce solid waste and allow useable material to be sold and recycled. DOE facilities also are replacing solvents and cleaners containing hazardous materials with less-toxic or non-toxic materials.

The APT facility design, consistent with this program, would minimize the extent of radiological contamination areas, thereby minimizing low-level radiological wastes (Shedrow 1997).

The APT would not use RCRA-regulated solvents, thereby minimizing the amount of mixed waste. To further reduce mixed-waste volumes, DOE would minimize the use of lead components (Shedrow 1997) because lead is a RCRA-regulated metal. To reduce waste volumes during component replacement, the Department would install the components as modules, so when there was a need to change equipment, it would be able to replace a component rather than a large piece of equipment.

If possible, DOE would recycle materials rather than dispose of them. DOE would recycle materials to the extent possible and has estimated that 243,000 cubic meters would be recyclable. DOE would store such material for future use or sell it to other users or salvage vendors. However, some materials would not be salvageable due to radioactive contamination. Additionally, the Department could burn oil that does not exceed certain radioactive levels for energy recovery rather than disposing of it as waste. Waste management practices would include the segregation of waste to minimize low-level radioactive and mixed-waste volumes (Shedrow 1997).

DOE conducted a pollution prevention opportunity assessment to identify pollution prevention and waste minimization opportunities, and is investigating those opportunities it considers promising, including materials substitution and design changes, as appropriate (Shedrow 1997).

**Energy Conservation.** Energy conservation and efficiency are also a part of waste minimization and pollution prevention in terms of incorporating efficiencies into the design process. For example, the Department's Preferred alternative is superconducting operation of accelerator for structures, which would require less electricity. DOE also has an active energy management program at SRS. Recently over 40 administrative buildings have undergone energy efficiency upgrades including replacement of light fixtures and ballasts, with ones with more efficiency, installation of infrared occupancy sensors, use of diode light sticks in exit signs, and the installation of insulating blankets on water heaters.

## References

Shedrow, B. C., 1997, submittal of Technical Data for Preparation of APT EIS, ESH-EAP-97-0082, Westinghouse Savannah River Site, Aiken, South Carolina.

# Chapter 7

Applicable Laws, Regulations, and Other Requirements

---

---

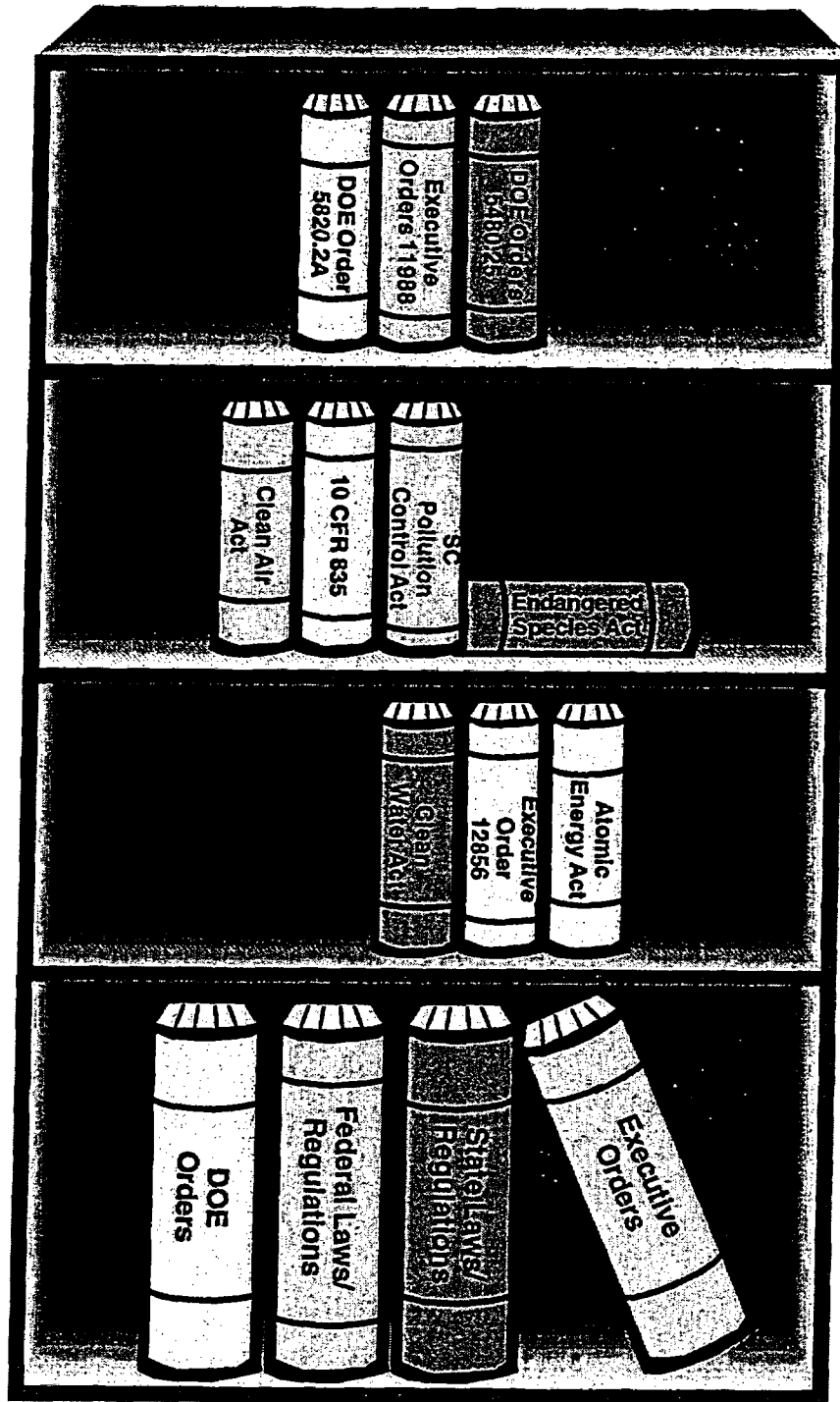

The National Environmental Policy Act (NEPA) is a “procedural” law that requires Federal Agencies to consider the environmental consequences of their actions. Coupled with NEPA, Federal and State agencies require permits and compliance with regulations established to protect the environment and the health and safety of workers and the public.

## CHAPTER 7. APPLICABLE LAWS, REGULATIONS, AND OTHER REQUIREMENTS

This chapter discusses the permit requirements and summarizes the major laws, regulations, Executive Orders, and DOE Orders that might apply to the construction and operation of the APT facilities. It also discusses the consultations and actions required to protect natural, cultural and historical resources, and endangered species. DOE would obtain permits for construction and operation of new APT drinking water system components, wastewater treatment and collection systems, new air sources, hazardous waste treatment and storage facilities, and obtain National Pollutant Discharge Elimination System permits for APT cooling water, process, and sanitary wastewater discharges. Determination is pending for Federal Clean Water Act requirements to perform a Section 316(a) Demonstration (Thermal Effects Study) and a Section 316(b) Impingement Study in relation to the APT cooling water alternatives. Determination is also pending for the requirement to obtain a permit to construct APT radiological air emission sources (stacks and process vents). This chapter does not discuss potential permit requirements related to the construction and operation of a new electric generating facility to supply APT power needs.

Section 7.1 discusses the major Federal and State of South Carolina statutes and regulations that impose environmental protection requirements on DOE and which require DOE to obtain a permit prior to construction and operation of the APT. Each of the applicable regulations establish how potential releases of pollutants and radioactive materials are to be controlled or monitored and include requirements for the issuance of permits for new operations or new emission sources. In addition to environmental permit requirements, the statutes may require consultations with various authorities to determine if an action (such as construction and operation of a facility such as APT) requires a permit or the implementation of protective or mitigative measures. Sections 7.1.1 and 7.1.2 discuss the environmental permitting process and lists the environmental permits and consultations (see Table 7-1) applicable to construction and operation of the APT.

Sections 7.2 and 7.3 address the major Federal regulations and Executive Orders, respectively, which address issues such as protection of public health and the environment, worker safety, and emergency planning. The Executive Orders clarify issues of national policy and set guidelines under which Federal agencies must act.

DOE implements its responsibilities for protection of public health, safety, and the envi-

ronment through a series of Departmental Orders (See Section 7.4) that are mandatory for operating contractors of DOE-owned facilities.

### 7.1 Statutes and Regulations Requiring Permits or Consultations

Environmental regulations require that the owner or operator of a facility obtain permits for the construction and operation of new (water and air) emissions sources, and for new domestic drinking water systems. To obtain these permits, the facility operator must apply to the appropriate government agency for a discharge permit for discharges of wastewater to the waters of the state and submit construction plans and specifications for the new emission sources, including new air sources. The environmental permits contain specific conditions with which the permittee must comply during construction and operation of a new emission source, describe pollution abatement and prevention methods to be utilized for reduction of pollutants, and contain emissions limits for pollutants which will be emitted from the facility. Section 7.1.1 discusses the environmental statutes and regulations under which DOE will be required to obtain permits. Table 7-1 lists the permits (WSRC 1996).

**Table 7-1. Environmental permits and consultations required by law.**

Activity/Topic	Law	Requirements	Agency
Site Preparation	Federal Clean Water Act (Section 404)	Wetlands 404 Permit (determination pending), Stormwater Pollution Prevention Plan for Industrial Activity	USACOR/1 SCDHEC <sup>2</sup>
Wastewater Discharges	Federal Clean Water Act S.C. Pollution Control Act	Stormwater Pollution Prevention/Erosion Control Plan for construction activity NPDES Permit(s) for Dewatering Basin Discharge, Cooling Water, and Balance of Plant Process Wastewater Discharges Process Wastewater Treatment Systems Construction and Operation Permits Sanitary Waste Water Pumping Station Tie-in Construction Permit; Permit to Operate	SCDHEC WSRC/EPD <sup>3</sup> SCDHEC SCDHEC WSRC/EPD
Cooling Water Discharges	Federal Clean Water Act [Section 316(a)] Federal Clean Water Act [Section 316(b)]	316(a) thermal effects study (determination pending) 316(b) impingement study (determination pending)	SCDHEC SCDHEC
Air	Clean Air Act - NESHAP	Rad Emissions - Permit to construct new emission source (if needed) Air Construction and Operation permits - as required. Fire Water Pumps; Diesel Generators General source - Stacks, Vents, Concrete batch plant Air Permit - Prevention of Significant Deterioration (PSD)	EPA <sup>4</sup> SCDHEC SCDHEC SCDHEC
Domestic Water	Safe Drinking Water Act	Construction and operation permits for line to domestic water system and Construction of API Water Tower	WSRC/EPD SCDHEC
Waste Management	Resource Conservation and Recovery Act (RCRA)	RCRA Permit - Radiological Waste Storage Facility	SCDHEC
Structures over 200 feet	Federal Aviation Administration (FAA)	Permit for Structures over 200 feet; API construction cranes, stacks, water tower	FAA
Historic Preservation	Archaeological Resource Protection Act; National Historic Preservation Act	Excavation or Removal Permit (determination pending); Consultation	Advisory Council on Historic Preservation; State Historic Preservation Officer
Endangered Species	Endangered Species Act	Consultation	U.S. Fish and Wildlife Service; National Marine Fisheries Service
Migratory Birds	Migratory Bird Treaty Act	Consultation	U.S. Fish and Wildlife Service

1. USACOR - United States Army Corps of Engineers.
2. South Carolina Department of Health and Environmental Control.
3. WSRC/EPD Westinghouse Savannah River Company Environmental Protection Department.
4. Environmental Protection Agency.

### 7.1.1 ENVIRONMENTAL PROTECTION PERMITS

*Clean Air Act, as amended, (42 USC 7401 et seq.), (40 CFR Parts 50-99); South Carolina Pollution Control Act [Section 48-1-30 et seq., South Carolina Department of Health and Environmental Control (SCDHEC) Regulation 61-62]*

The Clean Air Act, as amended, is intended to "protect and enhance the quality of the Nation's air resources so as to promote the public health and welfare and the productive capacity of its population." Section 118 of the Clean Air Act, as amended, requires each Federal agency, such as DOE, with jurisdiction over any property or facility that might result in the discharge of air pollutants, to comply with "all Federal, State, interstate, and local requirements" with regard to the control and abatement of air pollution.

The Act requires the U.S. Environmental Protection Agency (EPA) to establish National Ambient Air Quality Standards as necessary to protect public health, with an adequate margin of safety, from any known or anticipated adverse effects of a regulated pollutant (42 USC 7409). The Act also requires the establishment of national standards of performance for new or modified stationary sources of atmospheric pollutants (42 USC 7411) and requires specific emission increases to be evaluated so as to prevent a significant deterioration in air quality (42 USC 7470). Hazardous air pollutants, including radionuclides, are regulated separately (42 USC 7412). Air emissions are regulated by the EPA in 40 CFR Parts 50 through 99. In particular, radionuclide emissions are regulated under the National Emission Standard for Hazardous Air Pollutants Program (NESHAP) (see 40 CFR Part 61).

EPA has overall authority for the Clean Air Act; however, it delegates primary authority to states which have an established air pollution control program approved by EPA. In South Carolina, EPA has retained authority over radionuclide emissions (40 CFR Part 61) and has delegated to SCDHEC the responsibility for the rest of

the regulated pollutants under the authority of the South Carolina Pollution Control Act (48-1-10 et seq.) and SCDHEC Air Pollution Control Regulations 61-62.

Construction and operation permits or exemptions will be required for new nonradiological air emission sources (diesel generators, concrete batch plants etc.) constructed and operated at the APT facility. The permits will contain operating conditions and effluent limitations for pollutants emitted from the facilities (see Table 7-1).

DOE is currently determining if a NESHAP permit will be required for radiological emissions from the APT facilities (stacks, process vents, etc.). As described in 40 CFR Part 61.96, if the effective dose equivalent caused by all emissions from facility operations is projected to be less than 1 percent of the 10 millirem per year NESHAP standard, an application for approval to construct under 40 CFR Part 61.07 is not required to be filed. 40 CFR Part 61.96 also allows DOE to use, with prior EPA approval, methods other than EPA standard methods for estimating the source term for use in calculating the projected dose. DOE is currently investigating methods for estimating the APT source term in accordance with NESHAP requirements to calculate if the APT emissions would result in an effective dose equivalent of less than the 0.1 millirem per year level. Based on the results of this calculation, DOE will, prior to the start of construction, request EPA approval of the methodology for calculating the projected dose or complete a NESHAP permit application.

*Federal Clean Water Act, as amended (33 USC 1251 et seq.); SC Pollution Control Act (SC Code Section 48-1-10 et seq., 1976) (SCDHEC Regulation 61-9.122 et seq.)*

The Federal Water Pollution Act (commonly known as the Clean Water Act), was enacted to "restore and maintain the chemical, physical and biological integrity of the Nation's water." The Clean Water Act prohibits the "discharge of toxic pollutants in toxic amounts" to navigable



waters of the United States (Section 101). Section 313 of the Clean Water Act, as amended, requires all branches of the Federal Government engaged in any activity that might result in a discharge or runoff of pollutants to surface waters to comply with Federal, state, interstate, and local requirements.

In addition to setting water quality standards for the Nation's waterways, the Clean Water Act supplies guidelines and limitations (Sections 301-303) for effluent discharges from point-source discharges and provides authority (Sections 401-402) for the EPA to implement the National Pollutant Discharge Elimination System (NPDES) permitting program pursuant to 40 CFR Part 122 *et seq.*

EPA has delegated primary enforcement authority for the Clean Water Act and the NPDES Permitting Program to SCDHEC for waters in South Carolina. In 1996, SCDHEC, under the authority of the Pollution Control Act (48-1-10 *et seq.*) and Regulation 61-9.122, issued NPDES Permit SC0000175, which addresses wastewater discharges to SRS streams and NPDES permit SCG250162 which address general utility water discharges. The permit contains effluent limitations for physical parameters such as flow and temperature and for chemical pollutants with which the permittee/discharge must comply. DOE will apply for a discharge permit for the APT. (See Table 7-1)

In Section 402(p) of the Clean Water Act EPA established regulations (40 CFR Part 122.26) for issuing permits for stormwater discharges associated with industrial activity. Accordingly, SCDHEC has issued a General Permit for Storm Water Discharges Associated with Industrial Activities (Permit No. SCR000000) authorizing stormwater discharges to the waters of the State of South Carolina in accordance with effluent limitations, monitoring requirements, and conditions as set forth in the permit. This permit requires preparation and submittal of a Pollution Prevention Plan for all new and existing point source discharges associated with industrial activity. Accordingly, DOE-SR has developed a Storm Water Pollution Prevention

Plan (SWPPP) for storm water discharges at SRS. The SRS SWPPP would need to be revised to include pollution prevention measures to be implemented for operation of the APT (See Table 7-1) if industrial activities are exposed to stormwater. SCDHEC has issued a General Permit for stormwater discharges from construction activities that are "Associated with Industrial Activity" (Permit No. SCR100000). An approved plan would be needed that includes erosion control and pollution prevention measures to be implemented for construction activities.

Section 316(a) of the Clean Water Act authorizes EPA's Regional Administrator to set alternative effluent limitations on the thermal component of discharges if the owner/operator demonstrates that the proposed thermal effluent limitations are "more stringent than necessary to ensure the protection and propagation of a balanced population of fish, shellfish, and wildlife in or on a body of water into which the discharge is to made." In support of its request for a Section 316(a) exception, the owner/operator must submit with its permit application scientific documentation showing that the expected heated effluent will not result in appreciable harm to the indigenous aquatic community. This documentation is called a Section 316(a) Demonstration. This satisfactory demonstration would be made to SCDHEC if required, as the State NPDES authority and decisionmaker; however, program overview is by EPA. Under this regulation, a Section 316(a) Demonstration may be required for the APT cooling water alternative implemented. DOE has initiated discussions with SCDHEC regarding the potential need to conduct the Section 316(a) Demonstration. At the time of the writing of this Draft EIS those discussions have not been finalized.

Section 316(b) of the Clean Water Act directs EPA to establish standards that require that "...the location, design, construction, and capacity of cooling water intake structures reflect the best technology available for minimizing adverse environmental impact..." Under this regulation, a Section 316(b) Study, if required,

would be to demonstrate that the cooling water alternative implemented at APT meets the requirements of this section. It is not expected that a Section 316(b) study will be required for construction of the APT; however, a final determination on the need for Section 316(b) study has not yet been made (See Table 7-1).

Section 404 of the Clean Water Act requires that a 404 Permit be issued for discharge of dredge or fill material into the waters of the United States. The authority to implement these requirements has been given to the U.S. Army Corps of Engineers. Section 401 of the Clean Water Act requires certification that discharges from construction or operation of facilities, including discharges of dredged and fill material into navigable waters will comply with applicable water standards. This certification, which is granted by SCDHEC, is a prerequisite for the 404 permit. DOE does not believe that a 404 permit will be required for construction of the APT facilities; however a final determination has not been made. Some 404 permitting may be required for wastewater discharge conveyances, outfall structures, and roads and bridges.

*Federal Safe Drinking Water Act, as amended [42 USC 300 (F) et seq., 40 CFR Parts 100-149]; South Carolina Safe Drinking Water Act (Title 44-55-10 et seq.), State Primary Drinking Water Regulations, (SCDHEC R.61-58)*

The primary objective of the Safe Drinking Water Act (42 USC 300), as amended, is to protect the quality of the public water supplies and all sources of drinking water. The implementing regulations, administered by the EPA unless delegated to the States, establish standards applicable to public water systems. They promulgate maximum contaminant levels (including those for radioactivity), in public water systems, which are defined as water systems that serve at least 15 service connections used by year-round residents or regularly serve at least 25 year-round residents. Safe Drinking Water Act requirements have been promulgated by the EPA in 40 CFR Parts 100 through 149.

Other programs established by the Safe Drinking Water Act include the Sole Source Aquifer Program, the Wellhead Protection Program, and the Underground Injection Control Program.

EPA has delegated primary enforcement authority to SCDHEC for public water systems in South Carolina. Under the authority of the South Carolina Safe Drinking Water Act (44-55-10 et seq.), SCDHEC has established a drinking water regulatory program (R.61-58). For radioactive material, the regulations specify that the average annual concentration of manmade radionuclides in drinking water as delivered to the user by such a system shall not produce a dose equivalent to the total body or an internal organ greater than four millirem per year beta-gamma activity. Construction and operation permits will be required for the major new components (e.g., the APT water tower and distribution piping) associated with the APT. See Table 7-1.

*Resource Conservation and Recovery Act, as amended (Solid Waste Disposal Act) (42 USC 6901 et seq.); South Carolina Hazardous Waste Management Act, Section 44-56-30, South Carolina Hazardous Waste Management Regulations (R.61-79.124 et seq.)*

The treatment, storage, or disposal of hazardous and nonhazardous waste is governed by the Resource Conservation and Recovery Act (RCRA) and the Hazardous and Solid Waste Amendments of 1984. Pursuant to Section 3006 of the Act, any state that seeks to administer and enforce a hazardous waste program pursuant to RCRA may apply for EPA authorization of its program. The SCDHEC has received authorization to implement a hazardous waste program in the State of South Carolina. EPA and SCDHEC regulations implementing RCRA (40 CFR Parts 260-280; R.61-79.260-280) define hazardous wastes and specify hazardous waste transportation, handling, treatment, storage, and disposal requirements. The regulations imposed on a generator or a treatment, storage, or disposal facility vary according to the type and quantity of material or waste generated, treated, stored, or disposed. The method of treatment, storage, or disposal also affects the extent and

complexity of the requirements. These regulations require that facilities which store hazardous waste more than 90 days onsite, or treat hazardous waste obtain a RCRA Permit for this activity. The APT Radiological Waste Storage Building, which would store irradiated lead, would require a RCRA Permit.

***The Federal Facility Compliance Act (FFCA) (42 USC 6921 (et. seq.))***

The FFCA was enacted on October 6, 1992, amended the Resource Conservation Recovery Act. The FFCA waived sovereign immunity for fines and penalties for violations at Federal facilities associated with the management of mixed waste. However, a provision postpones fines and penalties after 3 years for mixed waste storage prohibition violations at DOE sites and requires DOE to prepare plans for developing the required treatment capacity for mixed waste stored or generated at each facility. Each plan must be approved by the host State or the EPA, after consultation with other affected States, and a consent order must be issued by the regulator requiring compliance with the plan. The Federal Facility Compliance Act further provides that DOE will not be subject to fines and penalties for land disposal restriction storage prohibition violations for mixed waste as long as it is in compliance with such an approved plan and consent order and meets all other applicable regulations. This would apply to mixed waste generated as a result of operation of the APT which are subject to requirements of the Resource Conservation and Recovery Act. On September 20, 1995, the SCDHEC approved, with modification, the Site Treatment Plan for SRS. SCDHEC issued a consent order, signed by DOE, requiring compliance with the plan on September 29, 1995. DOE would be required to notify SCDHEC of new mixed waste streams generated as result of APT operations.

***Federal Aviation Act of 1958 (49 USC 1504)  
Federal Aviation Administration Regulations (14 CFR Part 77)***

The Federal Aviation Administration requires that a permit be issued for any structure greater than 200 feet in height which would affect navigable airspace (See Table 7-1). A permit would be required for structures at the APT site greater than 200 feet in height. Potential APT structures which might require a permit are APT construction equipment (cranes), the APT water tower, and APT stacks.

**7.1.2 PROTECTION OF BIOLOGICAL, HISTORIC, AND ARCHAEOLOGICAL RESOURCES**

The following statutes pertain to protection of endangered and threatened animal and plants. Actions taken by DOE to evaluate potential APT sites in light of the statutes follow.

***Endangered Species Act, as amended (16 USC 1531 et seq.)***

The Endangered Species Act, as amended, is intended to prevent the further decline of endangered and threatened species and to restore these species and their habitats. The Act is jointly administered by the United States Departments of Commerce and Interior. Section 7 of the Act requires consultation with the Fish and Wildlife Service (Interior) and the National Marine Fisheries Service (Commerce) to determine if endangered and threatened species or their critical habitats are in the vicinity of the proposed (APT) action. DOE will comply with the Section 7 Process.

DOE has conducted a Threatened, Endangered, and Sensitive Species Listing and Habitat Evaluation of the preferred APT site. The survey results indicate that no known populations of threatened or endangered plant species are

located in the area (Imm 1997). In addition, the survey indicated that habitat conditions, or the potential for conditions, suitable for the establishment of federally-protected (animal) species such as the red-cockaded woodpecker, American alligator, or bald eagle do not exist at the site (Imm 1997).

***Migratory Bird Treaty Act, as amended (16 USC 703 et seq.)***

The Migratory Bird Treaty Act, as amended, is intended to protect birds that have common migration patterns between the United States and Canada, Mexico, Japan, and Russia. It regulates the harvest of migratory birds by specifying things such as the mode of harvest, hunting seasons, and bag limits. The Act stipulates that it is unlawful at any time, by any means, or in any manner to "kill...any migratory bird." DOE would be required to consult with the Fish and Wildlife Service regarding impacts to migratory birds and to evaluate ways to avoid or minimize these effects in accordance with the Fish and Wildlife Service Mitigation Policy during construction and operation of the APT.

***Bald and Golden Eagle Protection Act, as amended (16 USC 668-668d)***

The Bald and Golden Eagle Protection Act makes it unlawful to take, pursue, molest, or disturb bald and golden eagles, their nests, or their eggs anywhere in the United States (Sections 668, 668c). A permit must be obtained from the U.S. Department of the Interior to relocate a nest that interferes with resource development or recovery operations. If necessary, DOE would be required to obtain a permit for the disturbance or relocation of any bald or golden eagles discovered on the chosen APT site.

***National Historic Preservation Act, as amended (16 USC 470 et seq.)***

The National Historic Preservation Act, as amended, provides that sites with significant national historic value be placed on the *National Register of Historic Places*. No permits or certifica-

tions are required under the Act. However, if a particular Federal activity could impact an historic property resource, consultation with the Advisory Council on Historic Preservation will usually generate a Memorandum of Agreement, including stipulations that must be followed to minimize adverse impacts. Coordination with the South Carolina State Historic Preservation Officer (SC SHPO) ensures the proper identification of potentially significant sites and the implementation of appropriate mitigative actions. Should the chosen APT site contain possible historic sites or artifacts, coordination with the State Historic Preservation Officer would be necessary.

The Savannah River Archaeological Research Program (SRARP), evaluated the preferred APT site in 1986 for a new waste storage/disposal facility (Brooks et al. 1986). No archaeological sites were located during this effort. In June 1996, SRARP conducted additional surveys for the site that were not part of the 1986 work to further evaluate 20th-century homesites. No archaeological sites present on the preferred site were eligible for nomination to the National Registry of Historical Places. As a result, SRARP has indicated that it would request from the SC SHPO a determination of no effect from the construction of APT at the preferred site (Sassaman 1997).

The alternate site has not been subjected to systematic study; however, it is located in an area with low potential for significant prehistoric sites. The SRARP does not expect the existence of prehistoric sites that would be eligible for nomination to the National Historic Register (Sassaman 1997).

The following statutes pertain to potential archaeological sites associated with Native American lands. Actions taken by DOE to evaluate potential APT sites in light of the statutes follow.

***Archaeological Resource Protection Act, as amended (16 USC 470 et seq.)***

This Act requires a permit for any excavation or removal of archaeological resources from public

or Native American lands. Excavations must be undertaken for the purpose of furthering archaeological knowledge in the public interest, and resources removed are to remain the property of the United States. Consent must be obtained from the Indian Tribe owning lands on which a resource is located before a permit is issued, and the permit must contain terms or conditions requested by the Tribe.

***Native American Grave Protection and Repatriation Act of 1990 (25 USC 3001)***

This law directs the Secretary of Interior to assume responsibilities for repatriation of Federal archaeological collections and collections held by museums receiving Federal funding that are culturally affiliated with Native American Tribes. Major actions to be taken under this law include (1) establishing a review committee with monitoring and policy-making responsibilities, (2) developing regulations for repatriation, including procedures for identifying lineal descent or cultural affiliation needed for claims, (3) overseeing museum programs designed to meet the inventory requirements and deadlines of this law, and (4) developing procedures to handle unexpected discoveries of graves or grave goods during activities on Federal or tribal land.

***American Indian Religious Freedom Act of 1978 (42 USC 1996)***

This Act reaffirms Native American religious freedom under the First Amendment, and sets U.S. policy to protect and preserve the inherent and constitutional right of Native Americans to believe, express, and exercise their traditional religions. The Act requires that Federal actions avoid interfering with access to sacred locations and traditional resources that are integral to the practice of religion.

In conjunction with 1991 studies related to the New Production Reactor, DOE solicited the concerns of Native Americans about religious rights in the Central Savannah River Valley. During this study, three Native American groups -- the Yuchi Tribal Organization, the

National Council of Muskogee Creek, and the Indian People's Muskogee Tribal Town Confederacy -- expressed general concerns about SRS and the Central Savannah River Area, but did not identify specific sites as possessing religious significance. The Yuchi Tribal Organization and the National Council of Muskogee Creek are interested in plant species traditionally used in tribal ceremonies, such as redroot, button snakeroot, and American ginseng (DOE 1991). Redroot and button snakeroot are known to occur on the SRS (Batson, Angerman, and Jones 1985).

In addition, the Savannah River Archaeological Research Program (SRARP) conducted an archaeological survey of the preferred APT site in March 1997. The archeological review included potential sites associated with Native American activities or habitat. The resulting SRARP report stated that no archaeological sites present on the preferred site were eligible for nomination to the National Registry of Historical Places and further indicated that SRARP would request from the SC SHPO a determination of no effect from the construction of APT at the preferred site.

**7.2 Statutes and Regulations Related to Emergency Planning, Worker Safety, and Protection of Public Health and the Environment**

**7.2.1 ENVIRONMENTAL PROTECTION**

***National Environmental Policy Act (NEPA) of 1969, as amended (42 USC 4321 et seq.)***

NEPA establishes a national policy promoting awareness of the environmental consequences of human activity on the environment and consideration of environmental impacts during the planning and decisionmaking stages of a project. This Act requires Federal agencies to prepare a detailed statement on the environmental effects of proposed major Federal actions that might

significantly affect the quality of the human environment.

This EIS has been prepared in response to NEPA requirements and policies, and in accordance with Council on Environmental Quality (40 CFR Parts 1500 through 1508) and DOE (10 CFR Part 1021) regulations for implementing the procedural provisions of NEPA. It discusses reasonable alternatives and their potential environmental consequences.

***Pollution Prevention Act of 1990 (42 USC 13101 et seq.)***

The Pollution Prevention Act of 1990 establishes a national policy for waste management and pollution control that focuses first on source reduction, followed sequentially by environmentally safe recycling, treatment, and disposal. Disposal or releases to the environment should occur only as a last resort. In response, DOE has committed to participation in the Superfund Amendments and Reauthorization Act Section 313, U.S. EPA 33/50 Pollution Prevention Program. The goal for facilities already involved in Section 313 compliance is to achieve by 1997 a 33-percent reduction in the release of 17 priority chemicals from a 1993 baseline. On August 3, 1993, President Clinton issued Executive Order 12856, expanding the 33/50 program such that DOE must reduce its total releases of all toxic chemicals by 50 percent by December 31, 1999. In addition, DOE is requiring each of its sites to establish site-specific goals to reduce the generation of all waste types.

***Comprehensive Guideline for Procurement of Products Containing Recovered Materials (40 CFR Part 247)***

This regulation is issued under the authority of Section 6002 of the Resource Conservation and Recovery Act and Executive Order 12783, which set forth requirements for Federal agencies to procure products containing recovered materials for use in their operations using guidelines established by the EPA. The purpose of these regulations is to promote recycling by using government purchasing to

expand markets for recovered materials. RCRA Section 6002 requires that any purchasing agency, when using appropriated funds to procure an item, shall purchase it with the highest percentage of recovered materials practicable. The procurement of materials to be utilized in the construction and operation of the APT should be conducted in accordance with these regulations.

***Toxic Substances Control Act, as amended (USC 2601 et seq.) (40 CFR Part 700 et seq.)***

The Toxic Substances Control Act regulates the manufacture, use, treatment, storage, and disposal of certain toxic substances not regulated by the Resource Conservation and Recovery Act or other statutes, particularly polychlorinated biphenyls (40 CFR Part 761), chlorofluorocarbons (40 CFR Part 762), and asbestos (40 CFR Part 763). It is expected that the use of these materials at APT would be limited, or not occur; however, programs and procedures would need to be implemented to address appropriate management and disposal of waste generated as a result of their use.

**7.2.2 EMERGENCY PLANNING AND RESPONSE**

This section discusses the regulations which address protection of public health, worker safety, and require the establishment of emergency plans and the coordination with local and Federal agencies related to facility operations. DOE Orders generally set forth the programs and procedures required to implement the requirements of these regulations. See Section 7.4.

***Atomic Energy Act of 1954, as amended (42 USC 2011 et seq.)***

The Atomic Energy Act of 1954 authorizes DOE to establish standards to protect health or minimize dangers to life or property with respect to activities under its jurisdiction. Section 57b of the Act, which addresses the issue of Nuclear Nonproliferation, requires that any persons subject to U.S. jurisdiction, who engage

directly or indirectly in the production of special nuclear material be authorized to do so by the Secretary of Energy. Although tritium is not a special nuclear material, DOE has determined that the Atomic Energy Act and DOE regulations cover exports of production accelerator technology because the technology can be modified and used to produce plutonium, which is a special nuclear material. The issue of non-proliferation as related to tritium production is discussed in more detail in Chapter 1. Through a series of DOE Orders, DOE has established an extensive system of standards and requirements to ensure safe operation of its facilities. Section 7.3 includes a discussion of the DOE Orders which are applicable to the construction and operation of the APT.

***Atomic Energy Act of 1954, as amended (42 USC 2011 et seq.) Quantities of Radioactive Materials Requiring Consideration of the Need for an Emergency Plan for Responding to a Release (10 CFR Part 30.72 Schedule C)***

This list is the basis for both the public and private sector to determine if the radiological materials they deal with must have an emergency response plan for unscheduled releases. It is one of the threshold criteria documents for DOE Emergency Preparedness Hazards Assessments required by DOE Order 151.1, "Comprehensive Emergency Management System." An emergency response plan addressing APT operations would need to promulgated in accordance with this regulation.

***Reorganization Plan No. 3 of 1978, Public Health and Welfare (42 USC 5121 et seq.), Emergency Management and Assistance (44 CFR Part 1-399)***

These regulations generally include the policies, procedures and set forth the responsibilities of the Federal Emergency Management Agency, the Nuclear Regulatory Commission, and the Department of Energy for implementing a Federal Emergency Preparedness Program including radiological planning and preparedness. An emergency response plan, including radiological

planning and preparedness for APT operations, would need to prepared and implemented at APT, in accordance with this regulation.

***Emergency Planning and Community Right-to-Know Act of 1986 (42 USC 11001 et seq.) (also known as "SARA Title III")***

The Emergency Planning and Community Right-to-Know Act of 1986 requires emergency planning and notice to communities and government agencies of the presence and release of specific chemicals. EPA implements this Act under regulations found at 40 CFR Parts 355, 370, and 372. Under Subtitle A of this Act, Federal facilities provide various information (such as inventories of specific chemicals used or stored and releases that occur from these facilities) to the State Emergency Response Commission and the Local Emergency Planning Committee to ensure that emergency plans are sufficient to respond to unplanned releases of hazardous substances. Implementation of the provisions of this Act began voluntarily in 1987, and inventory and annual emissions reporting began in 1988. In addition, DOE requires compliance with Title III as a matter of Departmental policy. The requirements for this Act were promulgated by EPA in 40 CFR Parts 350 through 372. The SRS submits hazardous chemical inventory reports to the SCDHEC. The chemical inventory could change depending on the alternative(s) DOE implemented; however, subsequent reports would reflect any change to the inventory.

***Transportation of Hazardous Materials (49 USC 5101 et seq.); Hazardous Materials Tables & Communications, Emergency Response Information Requirements (49 CFR Part 172)***

The regulatory requirements for marking, labeling, placarding, and documenting hazardous materials shipments are defined in this regulation. It also specifies the requirements for providing hazardous material information and training. Materials shipped from APT would be required to comply with these regulations.

***Comprehensive Environmental Response, Compensation, and Liability Act of 1980, as amended (42 USC 9601 et seq.) National Oil and Hazardous Substance Contingency Plan (40 CFR Part 300 et seq.)***

More popularly known as "Superfund," the Act and implementing regulations provide the needed general authority for Federal and state governments to respond directly to hazardous substances incidents. The regulations require reporting of spills, including radioactive, to the National Response Center. APT operations would be required to comply with these regulations in the event of spills of hazardous materials at APT facilities. DOE Orders generally set forth the programs for development of internal procedures for implementing the regulations.

***Occupational Safety and Health Act of 1970, as amended (29 USC 651 et seq.); Occupational Safety and Health Administration Emergency Response, Hazardous Waste Operations and Worker Right to Know (29 CFR Part 1910 et seq.)***

The Occupational Safety and Health Act (29 USC 651) establishes standards to enhance safe and healthful working conditions in places of employment throughout the United States. The Act is administered and enforced by the Occupational Safety and Health Administration, a U.S. Department of Labor agency. While the Occupational Safety and Health Administration and EPA both have a mandate to reduce exposures to toxic substances, the Occupational Safety and Health Administration's jurisdiction is limited to safety and health conditions that exist in the workplace environment. In general, under the Act, it is the duty of each employer to furnish all employees a place of employment free of recognized hazards likely to cause death or serious physical harm. Employees have a duty to comply with the occupational safety and health standards and all rules, regulations, and orders issued under the Act. The Occupational Safety and Health Administration regulations (29 CFR) establish specific standards telling employers what must be done to achieve a safe and healthful working environment. This regu-

lation sets down the Occupational Safety and Health Administration requirements for employee safety in a variety of working environments. It addresses employee emergency and fire prevention plans (Section 1910.38), hazardous waste operations and emergency response (Section 1910.120), and hazards communication (Section 1910.1200) that enables employees to be aware of the dangers they face from hazardous materials at their workplace. DOE places emphasis on compliance with these regulations at its facilities and prescribes through DOE Orders the Occupational Safety and Health Act standards that contractors shall meet, as applicable to their work at Government-owned, contractor-operated facilities. DOE keeps and makes available the various records of minor illnesses, injuries, and work-related deaths required by Occupational Safety and Health Administration regulations.

***Noise Control Act of 1972, as amended (42 USC 4901 et seq.)***

Section 4 of the Noise Control Act of 1972, as amended, directs all Federal agencies to carry out "to the fullest extent within their authority" programs within their jurisdictions in a manner that furthers a national policy of promoting an environment free from noise that jeopardizes health and welfare.

### **7.3 Executive Orders**

The following executive orders would be in effect for the construction and operation of the APT. DOE Orders generally set forth the programs and procedures required to implement the requirements of the orders.

***Executive Order 11514 (Protection and Enhancement of Environmental Quality)***

Executive Order 11514 requires Federal agencies to monitor and control their activities continually to protect and enhance the quality of the environment and to develop procedures to ensure the fullest practicable provision of timely public information and understanding of Fed-



eral plans and programs with environmental impact to obtain the views of interested parties.

***Executive Order 11988 (Floodplain Management)***

Executive Order 11988 requires Federal agencies to establish procedures to ensure that the potential effects of flood hazards and floodplain management are considered for any action undertaken in a floodplain and that floodplain impacts be avoided to the extent practicable.

***Executive Order 11990 (Protection of Wetlands)***

Executive Order 11990 requires Government agencies to avoid any short- and long-term adverse impacts on wetlands wherever there is a practicable alternative.

***Executive Order 12856 (Right-to-Know Laws and Pollution Prevention Requirements)***

Executive Order 12856 requires all Federal agencies to reduce the toxic chemicals entering any waste stream. This order also requires Federal agencies to report toxic chemicals entering waste streams; improve emergency planning, response, and accident notification; and encourage clean technologies and testing of innovative prevention technologies.

***Executive Order 12898 (Environmental Justice)***

Executive Order 12898 requires Federal agencies to identify and address disproportionately high and adverse human health or environmental effects of its programs, policies, and activities on minority and low-income populations.

***Executive Order 12902 (Energy Efficiency and Water Conservation at Federal Facilities)***

Executive Order 12902 requires Federal agencies to develop and implement a program for conservation of energy and water resources.

## 7.4 DOE Regulations and Orders

Through the authority of the Atomic Energy Act, DOE is responsible for establishing a comprehensive health, safety, and environmental program for its facilities. The regulatory mechanisms through which DOE manages its facilities are the promulgation of regulations and the issuance of DOE Orders. Table 7-2 lists the major DOE Orders applicable to the construction and operation of the APT.

The DOE regulations address such areas as energy conservation, administrative requirements and procedures, nuclear safety, and classified information. For the purposes of this EIS, relevant regulations include 10 CFR Part 820, *Procedural Rules for DOE Nuclear Facilities*; 10 CFR Part 830, *Nuclear Safety Management; Contractor and Subcontractor Activities*; 10 CFR Part 835, *Occupational Radiation Protection*; 10 CFR Part 1021, *Compliance with NEPA*; and 10 CFR Part 1022, *Compliance with Floodplains/Wetlands Environmental Review Requirements*. DOE has enacted occupational radiation protection standards to protect DOE and its contractor employees. These standards are set forth in 10 CFR Part 835, *Occupational Radiation Protection*; the rules in this part establish radiation protection standards, limits, and program requirements for protecting individuals from ionizing radiation resulting from the conduct of DOE activities, including those conducted by DOE contractors. The activity may be, but is not limited to, design, construction, or operation of DOE facilities. These

**Table 7-2. DOE Orders and Notices relevant to the accelerator production of tritium.**

DOE Order/ Notice	Subject
151.1	Comprehensive Emergency Management System
225.1	Accident Investigations
231.1	Environment, Safety, and Health Reporting
232.1	Occurrence Reporting and Processing of Operations Information
420.1	Facility Safety
425.1	Startup and Restart of Nuclear Facilities
430.1	Life-Cycle Asset Management
440.1	Worker Protection Management for DOE Federal and Contractor Employees
441.1	DOE Radiological Health and Safety Policy
441.2	Extension of DOE 441.1
451.1A	National Environmental Policy Act Compliance Program
460.1A	Packaging and Transportation Safety
460.2	Departmental Materials and Packaging Management
470.1	Safeguards and Security Program
471.1	Identification and Protection of Unclassified Controlled Nuclear Information
471.2A	Information Security Program
472.1B	Personnel Security Activities
1270.2B	Safeguards Agreement with the International Atomic Energy Agency
1300.2A	Department of Energy Technical Standards Program
1360.2B	Unclassified Computer Security Program
3790.1B	Federal Employee Occupational Safety and Health Program
4330.4B	Maintenance Management Program
4700.1	Project Management System
5400.1	General Environmental Protection Program
5400.3	Hazardous and Radioactive Mixed Waste Program
5400.5	Radiation Protection of the Public and the Environment
5480.4	Environmental Protection, Safety, and Health Protection Standards
5480.17	Site Safety Representatives
5480.19	Conduct of Operations Requirements for DOE Facilities
5480.20A	Personnel Selection, Qualification, and Training Requirements for DOE Nuclear Facilities
5480.21	Unreviewed Safety Questions
5480.22	Technical Safety Requirements
5480.23	Nuclear Safety Analysis Reports
5480.25	Safety of Accelerator Facilities
5480.27	Equipment Qualification for Reactor and Nonreactor Nuclear Facilities
5484.1	Environmental Protection, Safety, and Health Protection Information Reporting Requirements
5630.12A	Safeguards and Security Inspection and Evaluation Program
5632.1C	Protection and Control of Safeguards and Security Interests
5633.3B	Control and Accountability of Nuclear Materials
5660.1B	Management of Nuclear Materials
5700.6C	Quality Assurance
5820.2A	Radioactive Waste Management
6430.1A	General Design Criteria

regulations would be in effect for the construction and operation of any facilities associated with the production and management of trit-

ium. DOE Orders generally set forth policy and the programs and internal procedures for implementing those policies.

## References

- Batson, W. T., J. S. Angerman, and J. T. Jones, 1985, *Flora of the Savannah River Plant: An Inventory of the Vascular Plants on the Savannah River Plant, South Carolina*, Savannah River Plant National Environmental Research Park Program, Aiken, South Carolina.
- Brooks, R. D., G. T. Hanson, and R. D. Brooks, 1986, An Intensive Archaeological Survey and Testing of Alternative, New Low-Level Radioactive and Hazardous/Mixed Waste Storage/Disposal Facilities, Savannah River Plant, Aiken and Barnwell Counties, South Carolina, manuscript on file with the Savannah River Archaeological Research Program, South Carolina Institute of Archaeology and Anthropology, University of South Carolina, Columbia, South Carolina.
- DOE (U.S. Department of Energy), 1991, American Indian Religious Freedom Act Compliance at the Savannah River Site, Savannah River Operations Office, Aiken, South Carolina.
- Imm, D. W., 1997, Threatened, Endangered, and Sensitive Species Listing and Habitat Evaluation for the Proposed APT Project, U.S.D.A. Forest Service -- Savannah River Institute, New Ellenton, South Carolina.
- Sassaman, K., 1997, memorandum to B. C. Shedrow (Westinghouse Savannah River Company), Savannah River Archaeological Research Program, South Carolina Institute of Archaeology and Anthropology, University of South Carolina.
- WSRC (Westinghouse Savannah River Company), 1996, Accelerator Production of Tritium Regulatory Roadmap, Draft Revision B, Aiken, South Carolina, May.

## LIST OF PREPARERS

Name	Degree	Expertise	Experience
<b>U.S. Department of Energy</b>			
Andrew R. Grainger	M.S., Wildlife Ecology, 1978 B.S., Natural Resources, 1975	NEPA Compliance Officer, NEPA Specialist for the EIS	12 years preparing NEPA documents; 18 years in terrestrial ecology, facility siting, wetlands ecology, endangered species
Richard Rustad	M.S., Nuclear Engineering, 1990 B.S., Physics, 1977	Document Manager for APT EIS. Principal reviewer for DOE.	4 years preparing NEPA documents; 22 years in nuclear navy and commercial nuclear power
Eric Schweitzer	M.U.R.P., Urban and Regional Planning, 1971 B.A., Geography, 1969	Deputy Director, DOE Office of Reconfiguration	15 years preparing and managing NEPA documents; 25 years land use and socioeconomic analyses
<b>Halliburton NUS Corporation</b>			
Yvonne F. Abernethy	M.S., Forest Management and Economics, 1984 B.S., Forest Management, 1979	Terrestrial and wetland ecology; threatened and endangered species	4 years preparing NEPA documents; 13 years in natural resource management and environmental planning
Fred R. Bingaman III	B.A., Economics, 1991 M.A., Applied Economics, in progress	Socioeconomics	6 years preparing NEPA documents; 7 years in economic analyses
John B. Bland	M.A., Economics, 1982 B.S., Mathematics, 1970	Socioeconomics and environmental justice	4 years preparing NEPA documents; 20 years in environmental and emergency management, military, and commercial security
Steven J. Connor	M.S., Physics, 1974, B.S., Physics, 1973	Noise, transportation, and environmental radiation	7 years preparing NEPA documents; 22 years in scientific, educational, and engineering disciplines

Name	Degree	Expertise	Experience
William J. Craig	M.S., Planning, 1977 B.S., Forestry, 1972	Project Manager for HNU.S. Land use and natural resource planning.	10 years preparing NEPA documents; 20 years utility fuel planning and powerplant siting
Philip C. Fulmer, CHP	Ph.D., Nuclear Engineering, 1993 M.S., Health Physics, 1990 B.S., Health Physics, 1989	Deputy Project Manager; radiation protection, internal and external radiation dosimetry	3 years preparing NEPA documents; 7 years as health physicist for commercial and government nuclear facilities
Gary L. Gunter, PG	B.S., Geology, 1984	Geology and hydrogeology	1 year preparing NEPA documents; 10 years as geologist/hydrogeologist
Mary N. Hoganson	M.S., Biology, 1989 B.S., Biology, 1984	Waste management	4 years preparing NEPA documents; 12 years in waste management and waste minimization
Philip R. Moore	M.S., Wildlife & Fisheries Biology, 1983 B.A., English, 1975	Aquatic ecology	8 years preparing NEPA documents; 17 years as fishery biologist and aquatic ecologist
Aparajita S. Morrison	B.S., Health Physics	Occupational and public health	1 year preparing NEPA documents; 11 years in environmental and occupational protection
James L. Oliver	B.S., Biology (Fisheries), 1971	Aquatic ecology, surface water, and wetlands	13 years preparing NEPA documents; 26 years in environmental research and impact assessment.
Eugene M. Rollins, CHP, CHMM	M.S.P.H., Health Physics, 1976 B.S., Nuclear Engineering, 1973	Occupational and public health	3 years preparing NEPA documents; 19 years in radiological health protection

Name	Degree	Expertise	Experience
Cindy L. Saban, CSP, CHMM	M.S., 1984, Health Physics M.P. H., 1982, Industrial Hygiene B.A., 1980, Biology	Occupational health and safety	1 year preparing NEPA documents; 12 years assessing occupational hazards associated with manufacturing and research facilities
John O. Shipman	B.A., English, 1966	Technical writing and editing	16 years editing and producing NEPA documents; 31 years producing scientific and technical documents
Diane S. Sinkowski, CHMM	M.E., Environmental Engineering, 1994 B.S., Nuclear Engineering Sciences, 1990	Air quality, human health, and traffic and transportation	3 years preparing NEPA documents; 6 years in air permitting, fate and transport modeling, human health impacts, environmental compliance, and health physics
Seshagiri Rao Tammara	M.S., Environmental Engineering, 1976 M.S., Chemical Engineering, 1971 B.S., Chemical Engineering, 1968	Health assessments, risk assessments, and transportation	10 years preparing NEPA documents; 25 years analyzing environmental impacts, health risk assessments and preparing sections for environmental assessments and EISs
Alan L. Toblin	M.S., Chemical Engineering, 1970 B.E., Chemical Engineering, 1968	Surface and groundwater	14 years preparing NEPA documents; 26 years in environmental (surface water, groundwater, atmospheric) transport analyses
James S. Willison, PE, CHP	M.S., Nuclear Engineering, 1982 B.S., Nuclear Engineering, 1980	Accident analysis, health physics, atmospheric transport, nuclear physics, emergency preparedness	1 year preparing NEPA documents; 13 years of accident analyses at nuclear facilities; health physics and radiological engineering

---

Name	Degree	Expertise	Experience
Paul F. Wise, CEA, CHMM	M.S., Biology, 1984 B.S., Biology, 1982	Environmental regulatory compliance	2 years preparing NEPA documents; 14 years in environmental, water quality, waste management, and environmental audits

---



**OCI REPRESENTATION STATEMENT**

**Contract No. DE-AC09-92SR18220  
Task Assignment 024  
New Subtask 10**

**Environmental Documentation/National Environmental  
Policy Act Requirements Support for the  
Production of Tritium at the Savannah River Site**

I hereby certify (or as a representative of my organization, I hereby certify) that, to the best of my knowledge and belief, no facts exist relevant to any past, present, or currently planned interest or activity (financial, contractual, personal, organizational or otherwise) which relate to the proposed work and bear on whether I have (or the organization has) a possible conflict of interest with respect to (1) being able to render impartial, technically sound, and objective assistance or advice, or (2) being given an unfair \*/ competitive advantage.

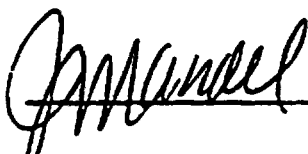
Signature:  Date: June 7, 1996

Name: Janet Mandel Organization: Halliburton NUS Corporation

Title: Contracting Officer

---

\*/ An unfair competitive advantage does not include the normal flow of benefits from the performance of this contract.

## GLOSSARY

*A-weighted decibel (dBA)*

A unit of weighted sound pressure level, measured by the use of a metering characteristic and the "A" weighting specified by American National Standard Institute S1.4-1971(R176). (See *decibel*).

*accelerator*

A device that accelerates charged particles (e.g., *electrons* or *protons*) to high velocities so they have high kinetic energy (i.e., the energy associated with motion); it focuses the charged particles into a *beam* and directs them against a *target*.

*air stripper*

A device that blows air through effluent, sewage, groundwater, etc., with an aerator to remove unwanted gas such as carbon dioxide, *volatile organic compounds*, or synthetic detergents.

*alpha radiation*

The least penetrating of the four common types of *radiation* (alpha, beta, gamma, and neutron). It consists of a positively charged particle with two *protons* and two *neutrons* that is emitted from the *nucleus* of certain *nuclides* during decay.

*aquifer*

A geologic formation that contains enough saturated porous material to permit movement of *groundwater* and to yield groundwater to wells and springs.

*aquitard*

A less permanent geological unit in a stratigraphic sequence. The unit is not permeable enough to transmit significant quantities of water.

*atomic number*

The number of *protons* in the *nucleus* of an element.

*attainment area*

An area that complies with National Ambient Air Quality Standards (NAAQS) for criteria pollutants; a nonattainment area does not meet these standards.

*Atterberg liquid limit value*

A soil index directly proportional to the compressibility of a soil.

*beam expander*

A device designed to expand the *proton beam* in an *accelerator* to a larger cross-sectional area.

*beamstop*

A device designed to absorb the full beam of an *accelerator*.

*bedrock*

The solid rock underlying surface materials (as soil).

*benthic*

Associated with the bottom of a body of water (ocean, lake, river, stream), as in "benthic organism."

*Best Management Practices (BMP)*

A practice or combination of practices that is determined by a state (or other planning agency) after problem assessment, examination of alternative practices, and appropriate public participation to be the most effective, practicable means of preventing or reducing the amount of pollution generated by nonpoint sources to a level compatible with air or water quality goals.

*beta radiation*

Consists of an elementary particle emitted from a *nucleus* during *radioactive decay*; it is negatively charged, is identical to an *electron*, and is easily stopped by a thin sheet of metal.

*blackwater*

Water in coastal plains, creeks, swamps, and rivers that is dark or black due to naturally occurring organic matter (tannic and humic acids) and certain minerals from soils and decaying vegetation.

*blanket*

That part of an *accelerator* with atoms that undergo a nuclear reaction to absorb *neutrons*, resulting (in the case of this EIS) in the production of a *tritium* atom and another (product) atom.

*blowdown*

Water discharged intentionally from a cooling tower system because of relatively high concentrations of salts.

*Carolina bay*

Oval-shaped, intermittently flooded, marshy depression of a type that occurs abundantly on the Coastal Plain of the Carolinas.

*cesium*

Naturally occurring element with 55 *protons* in its *nucleus*. A *radioactive isotope* of cesium, cesium-137, is a common fission product.

*chironomid*

Nonbiting midges, most of which have aquatic larvae. These chironomid larvae are found in a variety of aquatic habitats, including waters that are polluted and low in oxygen.

*cold standby*

See *standby*.

*commercial light-water reactor*

A reactor originally designed for the production of electricity.

*committed dose equivalent*

The *dose equivalent* calculated to be received by a tissue or organ over a 50-year period after the intake of a *radionuclide* in the body.

*committed effective dose equivalent*

The sum of the *committed dose equivalents* to various tissues in the body multiplied by their appropriate tissue weighting factor. Equivalent in effect to a uniform external dose of the same value.

*community* (environmental justice)

A group of people or a site in a specified area exposed to risks that could threaten health, ecology, or land values, or exposed to industry that stimulates unwanted noise, smell, industrial traffic, particulate matter, or other unaesthetic impacts.

*conceptual design*

Efforts to develop a project scope that will satisfy program needs; ensure project feasibility and attainable performance levels of the project for Congressional consideration; develop project criteria and design parameters for all engineering disciplines; and identify applicable codes and standards, quality assurance requirements, environmental studies, construction materials, space allowances, energy conservation features, health and safety safeguards, security requirements, and other features or requirements necessary to describe the project.

*conductivity*

The ability to transmit a fluid or energy flow.

*confining unit*

A body of impermeable or distinctly less permeable material stratigraphically adjacent to one or more *aquifers*.

*coolant*

A gas or liquid circulated through nuclear *reactor* or *accelerator* systems to remove or transfer heat.

*cooling water*

Water pumped into a nuclear *reactor* or *accelerator* to cool components and prevent damage from the intense heat generated when the reactor or accelerator is operating.

*critical habitat*

Habitat essential to the survival or reproduction of a species.

*cryogenics*

The science of physical phenomena at very low temperatures, approaching absolute zero.

*cumulative impacts*

Additive environmental, health, or socioeconomic effects that result from a number of similar activities in the area.

*cryogenic distillation*

A process where differences in the boiling points of hydrogen and tritium are used to separate the two isotopes. The process takes place at extremely cold temperatures. See also *cryogenics*.

*decay* (radioactive)

The spontaneous transformation of one *nuclide* into a different nuclide or into a different energy state of the same nuclide. The process results in the emission of nuclear *radiation*.

*decibel*

A unit for measuring the relative loudness of sounds. In general, a sound doubles in loudness for every increase of 10 decibels.

*decisionmaker*

Group or individual responsible for making a decision on constructing and operating an *accelerator* to produce *tritium* at the Savannah River Site.

*decoupler*

That part of an *accelerator* between the high-energy neutron source and the moderating blanket that contains *feedstock material* that will absorb low-energy *neutrons* and help protect the neutron source.

*Defense Waste Processing Facility*

Savannah River Site facility that processes high-level radioactive waste into a glass form for transport to a permanent disposal site.

*deinventory*

Packaging unused nuclear materials and placing them in storage on the SRS or at their source.

*demersal*

Refers to fish eggs that are relatively heavy and sink, because their specific gravity is greater than water.

*demographic*

Related to the statistical study of human populations, including size, density, distribution, and such vital statistics as age, gender, and ethnicity.

*design-basis accident*

For nuclear facilities, a postulated abnormal event used to establish the performance requirements of structures, systems, and components that are necessary to (1) maintain them in a safe shutdown condition indefinitely or (2) prevent or mitigate the consequences of the design-basis accident so that the general public and operating staff are not exposed to radiation in excess of appropriate guideline values. Normally, this is the accident that causes the most severe consequences when engineered safety features function as intended.

*design-basis events*

Postulated disturbances in process variables that can potentially lead to *design-basis accidents*.

*diatom*

Any of a class of planktonic one-celled or colonial algae with skeletons of silica (a mineral consisting of silicon and oxygen).

*dinoflagellate*

Any of an order of unicellular flagellated algae, many of which have the ability to move spontaneously.

*dipteran*

A large group of insects, usually "true" flies with one pair of wings, but also including midges, mosquitoes, and gnats. Many dipterans have aquatic larvae.

*dose*

The energy imparted to matter by *ionizing radiation*. The unit of absorbed dose is the *rad*, which is equal to 0.01 joule per kilogram of irradiated material in any medium.

*dose equivalent*

A term used to express the amount of effective *radiation* when modifying factors have been considered. It is the product of absorbed dose (*rads*) multiplied by a quality factor and other modifying factors. It is measured in *rem* (Roentgen equivalent man).

*drift*

Mist or spray carried into the atmosphere with the effluent air vapor from a cooling tower.

*ecosystem*

The community of living things and the physical environment in which they live.

*effluent*

A liquid or airborne material released to the environment; in common usage, a liquid release.

*effluent monitoring*

The collection and analysis of samples or measurements of liquid and gaseous effluents to characterize and quantify contaminants, assess *radiation exposure* to members of the public, and demonstrate compliance with applicable standards; occurs at the point of discharge, such as an air stack or drainage pipe

*EIS (environmental impact statement)*

A legal document required by the National Environmental Policy Act (NEPA) of 1969, as amended, for Federal actions involving significant or potentially significant environmental impacts. A tool for decisionmaking, it describes the positive and negative impacts of the proposed action and the alternative actions.

*electron*

An elementary particle with a mass of  $9.107 \times 10^{-28}$  gram (or 1/1837 of a *proton*) and a negative charge. Electrons surround the positively charged *nucleus* and determine the chemical properties of the atom.

*emission standards*

Legally enforceable limits on the quantities and kinds of air contaminants that may be emitted to the *atmosphere*.

*entrainment*

The capture and inclusion of organisms in the cooling water systems of such facilities as *reactors* and *accelerators*. The organisms involved, which would depend on size of the intake screen opening, include *phyto-* and *zooplankton*, fish eggs and larvae (*ichthyoplankton*), shellfish larvae, and other forms of aquatic life.

*environment*

The sum of all external conditions and influences affecting the life, development, and ultimately the survival of an organism.

*environmental justice*

The fair treatment of people of all races, cultures, incomes, and educational levels with respect to the development, implementation, and enforcement of environmental laws, regulations, and policies. Fair treatment implies that no population of people should be forced to shoulder a disproportionate share of the negative environmental impacts of pollution or environmental hazards due to a lack of political or economic strength.

*environmental surveillance*

The collection and analysis of samples of air, water, soil, foodstuffs, *biota*, and other media and the measurement of external *radiation* to demonstrate compliance with applicable standards, assess radiation exposures to members of the public, and assess effects, if any, on the local environment.

*ephemeropteran*

Any of a group of small terrestrial insects (mayflies) with delicate, transparent wings and large compound eyes. They occur in the vicinity of bodies of fresh water, in which the immature stages develop.

*exposure (to radiation)*

The incidence of *radiation* on living or inanimate material by accident or intent. Background exposure is the exposure to natural background ionizing radiation. Occupational exposure is the exposure to ionizing radiation that occurs during a person's working hours. Population exposure is the exposure to a number of persons who inhabit an area.

*exposure pathway*

The course a chemical or physical agent takes from the source to the exposed organism. The pathway describes a unique mechanism by which an individual or population is exposed to chemicals or physical agents at or originating from the site. Each exposure pathway includes a source or release from a source, an exposure point, and an exposure route. If the exposure point differs from the source, a transport/exposure medium (e.g., air) is included.

*extrusion press*

A device in which heated or unheated material is forced through a shaping orifice to become one continuously formed piece.

*fallout*

The descent to earth and deposition on the ground of particulate matter (usually *radioactive*) from the atmosphere.

*fault (geological)*

A fracture in the earth's crust accompanied by a displacement of one side in relation to the other.

*feedstock material*

Neutron-absorbing material in the target/blanket structure that is transformed by neutron absorption into the desired product (e.g., tritium).

*floodplain*

The relatively smooth valley floors adjacent to and formed by rivers subject to overflow.

*getter*

A special metal placed in a vacuum tube during manufacture and vaporized after the tube is evacuated; when the vaporized metal condenses it absorbs residual gases. See *Tritium Separation Facility*.

*greater-than-Class-C waste*

Radioactive waste that contains long-lived radionuclides and requires special disposal considerations.

*grid*

A transmission and distribution system for electric power.

*Gross Regional Product*

The total value of the goods and services produced in a defined region during a year.

*half-life (radiological)*

The time in which half the atoms of a *radioactive* substance disintegrate to another nuclear form. Half-lives vary from millionths of a second to billions of years.

*hazardous waste*

Waste (solid, semisolid, or liquid) with the characteristics of ignitability, corrosivity, toxicity, or reactivity, as defined by the Resource Conservation and Recovery Act and identified or listed in 40 CFR 261 or the Toxic Substances Control Act.

*heat exchanger*

A device that transfers heat from one fluid (liquid or gas) to another. It allows heat to pass from one system to another without mixing the contents of the systems.

*heavy-water*

Water in which the hydrogen of the water molecule consists entirely of the heavy hydrogen isotope having a mass number of 2; also called deuterium oxide (D<sub>2</sub>O).

*heavy water reactor*

A nuclear reactor in which *heavy water* serves as a moderator and sometimes as a coolant.

*high-level waste*

The highly *radioactive* liquid wastes that result from the chemical processing of spent nuclear fuel, including liquid waste produced directly in reprocessing and any solid waste derived from the liquid. High-level waste contains a combination of transuranic waste and fission products in concentrations requiring permanent isolation.

*high-temperature gas-cooled reactor*

A type of nuclear reactor design that uses a gas (e.g., helium) for cooling rather than water. It permits more efficient use of uranium and some use of thorium in its fuel cycle. It also offers greater efficiency than light-water reactors.

*ichthyoplankton*

The early life stages of fish (eggs and larvae) that spend part of their life cycle as free-floating plankton.



*impingement*

The process by which aquatic organisms too large to pass through the screen of a water intake system become trapped against the screens and are unable to escape.

*incineration*

The efficient burning of combustible solid and liquid wastes to destroy organic constituents and reduce the volume of the waste. The greater the burning efficiency, the cleaner the air emission. Incineration of *radioactive* materials does not destroy the *radionuclides* but does significantly reduce the volume of the waste.

*inductive output tube*

A device designed to amplify microwaves in a manner different from that in a *radiofrequency power tube*. The *electron* beam current varies depending on the microwave signal. In addition, it is typically smaller than a radiofrequency power tube and has greater efficiency, providing the same microwave amplification with less energy.

*infrastructure*

The system of public works of a county, state, or region; also, the resources (buildings or equipment) required for an activity.

*injector*

A device that provides *protons* for an *accelerator* by heating hydrogen gas to a plasma state in which the hydrogen atoms lose their *electrons*, thereby giving the hydrogen *nuclei (protons)* a positive charge. An electric voltage removes the protons from the injector.

*in situ*

In or at the natural or original position or location.

*ion*

An atom or molecule that has gained or lost one or more *electrons* to become electrically charged.

*ion exchange*

Process in which a solution containing soluble *ions* to be removed is passed over a solid ion-exchange medium, which removes the soluble ions by exchanging them with labile ions from the surface of the medium. The process is reversible so trapped ions can be collected (eluted) and the column regenerated.

*ion-exchange medium*

A substance (see *resin*) that preferentially removes certain *ions* from a solution.

*ionizing radiation*

Radiation capable of displacing *electrons* from atoms or molecules to produce ions.

*irradiation*

Exposure to *radiation*.

*isotope*

An atom of a chemical element with a specific atomic number and atomic mass. Isotopes of the same element have the same number of *protons* but different number of *neutrons*. Isotopes are identified by the name of the element and the total number of protons and neutrons in the nucleus. For example, plutonium-239 is a plutonium atom with 239 protons and neutrons.

*klystron*

An electron tube used for the amplification of microwaves (see *radiofrequency power tube*).

*latent cancer fatalities*

Deaths resulting from cancer that has become active after a latent period (i.e., a period of inactivity).

*laydown*

Area of construction site used to sort and store construction materials.

*light water*

Ordinary water containing hydrogen atoms with no neutrons in their nucleus.

*light-water reactor*

A nuclear *reactor* that uses ordinary water to cool the reactor core and to moderate (reduce the energy of) the *neutrons* created in the core by fission reactions.

*low-income community*

A community in which 25 percent or more of the population is identified as living in poverty.

*low-level waste*

Radioactive waste not classified as *high-level waste*, *transuranic waste*, *spent nuclear fuel*, or byproduct material.

*macroinvertebrate*

Small animal, such as a larval aquatic insect, that is visible to the naked eye and has no vertebral column, as in "benthic macroinvertebrate."

*makeup water*

Replacement for water lost through *drift*, *blowdown*, or *evaporation* (as in a cooling tower).

*maximally exposed individual*

A hypothetical member of the public at the SRS boundary located to receive the maximum possible *dose equivalent* from a given exposure scenario.

*MeV* (million electron-volts)

A unit used to quantify energy. In this EIS, it describes a particle's kinetic energy, which is an indicator of particle speed.

*millirem*

One thousandth of a *rem*. (See *rem*.)

*minority communities*

A population classified by the Bureau of the Census as Black, Hispanic, Asian and Pacific Islander, American Indian, Eskimo, Aleut, and other nonwhite persons, the composition of which is at least equal to or greater than the state minority average of a defined area or jurisdiction.

*mixed waste*

Waste material that contains both *hazardous waste* and *radioactive* source, special nuclear, or byproduct material (subject to the Atomic Energy Act of 1954).

*Molecular sieve*

Device in the Tritium Separation Facility used to separate impurities and spallation products from the hydrogen/helium gas stream.

*National Ambient Air Quality Standards*

Air quality standards established by the Clean Air Act, as amended. The primary National Ambient Air Quality Standards are intended to provide the public health with an adequate margin of safety, and the secondary National Ambient Air Quality Standards are intended to provide the public welfare from known or anticipated adverse impacts of a pollutant.

*National Pollutant Discharge Elimination System*

Federal permitting system required for liquid effluents regulated through the Clean Water Act, as amended.

*National Register of Historic Places*

A list maintained by the Secretary of the Interior of districts, sites, buildings, structures, and objects of prehistoric or historic local, state, or national significance.

*neutron*

An uncharged elementary nuclear particle that has a mass approximately the same as that of a *proton*; it is present in all atomic nuclei except that of hydrogen-1. A free neutron is unstable and decays with a half-life of about 13 minutes into an electron and a proton.

*nonattainment area*

See *attainment area*.

*nuclide*

An atomic *nucleus* specified by atomic weight, atomic number, and energy state; a *radionuclide* is a radioactive nuclide.

*odonate*

Any of a group of large predatory insects (dragonflies and damselflies) with two pairs of long, narrow wings and biting mouth parts, which are aquatic in immature (nymphal) stages.

*Occupational Safety and Health Administration*

Federal agency responsible for oversight and regulation of workplace health and safety.

*off-normal event*

An unexplained event that exceeds the range of normal operating parameters, but that usually does not have a significant impact (inside or beyond the SRS boundary).

*oligochaete*

A segmented worm with the same fundamental structure as an earthworm that is often found in polluted rivers or streams.

*oxides of nitrogen (NO<sub>x</sub>)*

Primarily nitrogen oxide (NO) and nitrogen dioxide (NO<sub>2</sub>), these compounds are produced in the combustion of fossil fuels, and can constitute an air pollution problem.

*ozone*

A compound of oxygen in which three oxygen atoms are chemically attached to each other.

*perched water*

Groundwater from a restricted or a relatively small area that lies above a more extensive *aquifer*.

*periphyton*

Algae that live attached to underwater surfaces.

*permeator*

A device that selectively allows the passage of hydrogen atoms and prevents the passage of other elements. Used to separate hydrogen and tritium from helium.

*person-rem*

The measure of radiation dose commitment to a specific population; the sum of the individual doses received by a population segment.

*pH*

A measure of the hydrogen ion concentration in aqueous (made from, with, or by water) solution. Pure water has a pH of 7, acidic solutions have a pH less than 7, and basic solutions have a pH greater than 7.

*phytoplankton*

Microscopic floating plants, such as diatoms.

*prime farmland*

Land that has the best combination of physical and chemical characteristics for producing food, feed, forage, fiber, oilseed, and other crops with minimum inputs of fuel, fertilizer, pesticides, and labor without intolerable soil erosion, as determined by the Secretary of Agriculture.

*privatization*

The transfer of government operations to the private sector.

*proton*

An elementary nuclear particle with a positive charge equal in magnitude to the negative charge of the *electron*; it is a constituent of all atomic nuclei, and the atomic number of an element indicates the number of protons in the nucleus of each atom of that element.

*protozoa*

Mobile, single-celled animals from five to several hundreds microns long that are found wherever there is water. They move by cilia, flagella, or pseudopods. Most are harmless or helpful; a few cause illness in humans. Because they are easily seen with optical microscopes, they can be valuable indicators of water quality conditions in a lake or stream.

*quantitative analysis*

A form of analysis that uses defined values to determine the amount of one or more components.

*radiation*

The emitted particles and *photons* from the nuclei of *radioactive* atoms; a short term for *ionizing radiation* or nuclear radiation, which are different from nonionizing radiation such as microwaves, ultraviolet rays, etc.

*radioactivity*

The spontaneous decay of unstable atomic nuclei accompanied by the emission of *radiation*.

*radiofrequency power tube*

An established technology that radar installations and television broadcast stations use to generate broadcast signals. It uses a beam of *electrons* to amplify a microwave signal; the produced *electron beam* current is fixed, regardless of the strength of the microwave signal. See *inductive output tube*.

*radiological*

Related to radiology, the science that deals with the use of *ionizing radiation* to diagnose and treat disease.

*radionuclide*

See *nuclide*.

*reactor*

A device or apparatus in which a chain reaction of fissionable material is initiated and controlled; a nuclear reactor.

*receiving waters*

Rivers, lakes, oceans, or other bodies of water into which treated or untreated waste waters are discharged.

*Record of Decision (ROD)*

A document that provides a concise public record of an agency decision on a proposed action for which it prepared an EIS. An ROD identifies the alternatives considered in reaching the decision, the environmentally preferable alternative(s), factors the agency balanced in making the decision, if the agency has adopted all practicable means to avoid or minimize environmental harm and if not, why not.

*recycling*

For this EIS, recovering residual tritium from weapons components, purifying it, and refilling the components with both recovered and new tritium.

*release fraction*

The calculated fraction of material that an accident could release.

*rem (Roentgen equivalent man)*

The unit of dose equivalent for human radiation exposure. It is equal to the product of the absorbed dose in rads and a quality factor.

*Tritium Loading Facility (also known as Replacement Tritium Facility)*

Underground SRS facility in which DOE unloads gases from reservoirs returned from the Department of Defense, separates and purifies the gases useful hydrogen isotopes (tritium and deuterium), mixes the gases to exact specifications, and loads the reservoirs

*resin*

An ion-exchange medium; organic polymer used for the preferential removal of certain ions from a solution.

*Resource Conservation and Recovery Act*

The Act that provides a "cradle to grave" program for hazardous waste, which established, among other things, a system for managing hazardous waste from its generation until its ultimate disposal.

*Richter Scale*

A scale for measuring earthquakes with graded steps from 1 to 10. Each step is about 60 times greater than the preceding step, adjusted for different regions of the earth.

*risk*

In accident analysis, the probability-weighted consequence of an accident, defined as the accident frequency per year multiplied by the dose. Risk is also used commonly in other applications to describe the probability of an event occurring.

*River Water System*

A system of large concrete pipes built to provide secondary cooling water to the five SRS production reactors. The system pumped water from the Savannah River to the reactor areas, where the water passed through *heat exchangers* to absorb heat from the reactor core. Heated discharge water returned to the river in onsite streams.

*rotifer*

Tiny aquatic and semi-aquatic animals that occur in a wide variety of habitats and include free-swimming, planktonic, and parasitic forms.

*sanitary waste*

Solid waste that is neither hazardous as defined by the *Resource Conservation and Recovery Act* nor radioactive, sanitary waste streams include paper, glass, discarded office material, and construction debris.

*seismicity*

Capacity for earth-movement events, usually earthquakes.

*soil horizon*

A layer of soil, approximately parallel to the surface, that differs from adjacent layers in chemical and physical properties.

*spallation*

A nuclear reaction in which light particles are ejected as the result of bombardment (as by high-energy *protons*)

*special nuclear materials*

Plutonium, uranium-233, uranium enriched in the isotope 233 or 235, and any other material DOE determines to be special nuclear material.

*spent nuclear fuel*

Fuel that has been withdrawn from a nuclear reactor following irradiation, the constituent elements of which have not been separated.

*standby (cold standby)*

Condition under which a facility is maintained in a protected condition to prevent deterioration such that it can be brought back into operation.

*sulfur dioxide*

A heavy, pungent, toxic gas, used as a preservative or refrigerant, that is a major air pollutant.

*superconducting*

Exhibiting a complete disappearance of electrical resistance in various metals at temperatures near absolute zero.

*Superfund*

A trust fund established by the Comprehensive Environmental Response, Compensation, and Liability Act and amended by the Superfund Amendment and Reauthorization Act that finances long-term remedial action for hazardous waste sites.

*supply*

For this EIS, the production of tritium in a reactor or an accelerator and the subsequent extraction of the tritium in pure form for use in weapons

*switchyard*

A device that determines the destination of a charged particle beam by using magnets to influence its travel path.

*target*

A tube, rod, or other form containing material that, on being irradiated in a *nuclear reactor* or an *accelerator* would produce a desired end product.

*taxa (plural of taxon)*

Classes or types of organisms.

*thermophilic*

Related to plants and animals that thrive in heated waters.

*tier*

To link to another in a hierarchical chain. An upper-tier document might be programmatic to the entire DOE complex of sites; a lower-tier document might be specific to one site or process.

*total particulate matter*

Fine liquid or solid particles such as dust, smoke, mist, fumes, or smog found in air or emissions.

*trichopteran*

Any of a group of small, moth-like insects (caddisflies) found near streams and lakes with larvae and pupae that are aquatic.

*tritium*

A radioactive isotope of hydrogen and an essential component of every warhead in the current and projected U.S. nuclear weapons stockpile. The tritium enables warheads to perform as designed.

*Tritium Extraction Facility*

A proposed facility at the Savannah River Site that would extract tritium from *target* material irradiated in either an *accelerator* or a commercial light-water *reactor*.

*Tritium Separation Facility*

A proposed facility at the Savannah River Site that would separate hydrogen isotopes (protium, deuterium, and tritium) from helium using metal getter beds that would absorb hydrogen while allowing helium to pass through, and would separate tritium from the other hydrogen isotopes using cryogenic distillation.

*uninvolved worker*

For this EIS, an SRS worker who is not involved in the operation of the *accelerator*, and who is assumed to be at least 640 meters from the point of release.

*volatile organic compound*

An organic compound with a vapor pressure greater than 0.44 pound per square inch at standard temperature and pressure.

*watershed*

The area drained by a body of water.

*water quality standards*

Provisions of Federal or state law that consist of a designated use or uses for the waters of the United States and water quality standards for such waters based on their uses. Water quality standards are used to protect the public health or welfare, enhance the quality of water, and serve the purposes of the Clean Water Act.

*waveguides*

Hollow metal conduits that transmit radiofrequency waves to the *beam* in an *accelerator*.



*wetlands*

Land or areas exhibiting the following: hydric soil conditions, saturated or inundated soil during some portion of the year, and plant species tolerant of such conditions; also, areas that are inundated or saturated by surface water or groundwater at a frequency and duration sufficient to support, and that under normal circumstances do support, a prevalence of vegetation typically adapted for life in saturated soil conditions. Wetlands generally include swamps, marshes, bogs, and similar areas.

*zooplankton*

Microscopic planktonic (floating) animals, many of which serve as food for fish.

# Appendix A

Facility and Process Descriptions

---

---

**APPENDIX A**

**FACILITY AND PROCESS DESCRIPTIONS**

## TABLE OF CONTENTS

<u>Section</u>	<u>Page</u>
A.1 Linear Accelerator .....	A-1
A.1.1 Accelerator Tunnel.....	A-1
A.1.2 Injector System .....	A-3
A.1.3 Low-Energy (up to 100 mev) Linear Accelerator System.....	A-4
A.1.4 High-Energy (Greater Than 100 mev) Linear Accelerator System.....	A-4
A.1.4.1 High-Energy Room Temperature Linac.....	A-4
A.1.4.2 High-Energy Superconducting Radiofrequency Linac.....	A-7
A.1.5 High-Energy Beam Transport System, Switchyard, and Beam Expander System .....	A-8
A.2 Radiofrequency Gallery .....	A-9
A.2.1 Klystron Alternative for RF System.....	A-12
A.2.2 Inductive Output Tube Alternative for RF.....	A-13
A.3 Target/Blanket System .....	A-15
A.3.1 Target/Blanket Structure .....	A-15
A.3.2 Helium-3 Feedstock Material Alternative.....	A-18
A.3.3 Lithium-6 Feedstock Material Alternative.....	A-20
A.3.4 Beamstop Systems.....	A-21
A.3.4.1 Low-Energy and Intermediate-Energy Beamstops.....	A-21
A.3.4.2 High-Energy Beamstop .....	A-22
A.3.4.3 Removable High-Energy Beamstop.....	A-24
A.4 Tritium Separation Facility.....	A-25
A.4.1 Tritium Extraction System.....	A-25
A.4.2 Isotope Separation System.....	A-27
A.4.3 Waste Gas Tritium Cleanup System.....	A-28
A.4.4 Helium-3 Supply System .....	A-29
A.4.5 Tritium Storage System .....	A-29
A.5 Support Facilities at the Accelerator Site.....	A-31
A.5.1 APT Safety Systems .....	A-31
A.5.2 Administrative Building.....	A-32
A.5.3 Access Control Building.....	A-32
A.5.4 Backup Power Facilities.....	A-32
A.5.5 Operations Building.....	A-33
A.5.6 Maintenance Building .....	A-33
A.5.7 RF Tube Maintenance Facility .....	A-33
A.5.8 Mechanical-Draft Cooling Tower Structures.....	A-34
A.5.9 Mechanical Services Buildings.....	A-34
A.5.10 Simulator and Training Building.....	A-34
A.5.11 Fire Pump House and Water Storage Tanks.....	A-34
A.5.12 Demineralizer Building.....	A-35
A.5.13 Security Building.....	A-35
A.5.14 Cryogenics System.....	A-35
A.5.15 Target/Blanket Staging Building.....	A-37

## TABLE OF CONTENTS (continued)

<u>Section</u>	<u>Page</u>
A.5.16 Radioactive Waste Treatment System .....	A-37
A.5.16.1 Solid Radioactive Waste System .....	A-38
A.5.16.2 Liquid Radioactive Waste System .....	A-38
A.5.16.2.1 Heavy-Water Radioactive Waste System .....	A-38
A.5.16.2.2 Light-Water Liquid Radioactive Waste System .....	A-39
A.5.16.2.3 Process-Water Radioactive Waste System .....	A-40
A.5.16.3 Gaseous Radioactive Waste System .....	A-40
A.5.16.4 Radioactive Waste Building .....	A-41
A.6 Other Support Facilities and Systems at the Savannah River Site .....	A-41
A.6.1 Tritium Loading Facility .....	A-41
A.6.2 Tritium Processing Facilities/Tritium Extraction Facility .....	A-43
A.6.3 M-Area Facilities .....	A-43
A.6.4 SRS Waste Facilities .....	A-43
A.6.4.1 Low-Level Solid Waste .....	A-46
A.6.4.2 Low-Level Liquid Waste .....	A-46
A.6.4.3 Long-Lived and Intermediate-Level Waste .....	A-46
A.6.4.4 Hazardous and Mixed Waste .....	A-48
A.6.5 River Water System .....	A-49
A.6.6 K-Area Cooling Tower .....	A-49
References .....	A-50

### List of Tables

<u>Table</u>	<u>Page</u>
A-1 Room Temperature Linac System .....	A-6
A-2 M-Area Facility functional support compatibility .....	A-44

### List of Figures

<u>Figure</u>	<u>Page</u>
A-1 Conceptual layout of APT facilities and structure .....	A-2
A-2 Injector system (LANL 1997) .....	A-3
A-3 Configurations of CCDTL (top 3) and CCL (lower 2) structures (LANL 1997) .....	A-5
A-4 Room-temperature linac system (2-kg production level) (LANL 1997) .....	A-5
A-5 Funneled Room-Temperature Linac System (3-kg production level) (LANL 1997) .....	A-6
A-6 Superconducting High-Energy Linac System (3-kg production level) (LANL 1997) .....	A-7
A-7 High-Energy Beam Transport and Expander System (LANL 1997) .....	A-8
A-8 Switchyard (LANL 1997) .....	A-10

## TABLE OF CONTENTS (continued)

### List of Figures (continued)

<u>Figure</u>		<u>Page</u>
A-9	Block diagram of RF Power System (LANL 1997) .....	A-11
A-10	Waveguide layout in the medium $\beta$ HE linac (LANL 1997).....	A-14
A-11	Schematic diagram of an inductive output tube (Badger).....	A-15
A-12	Top view of Target/Blanket Building and heat removal systems (LANL 1997) .....	A-16
A-13	Target/blanket assembly (LANL 1997).....	A-16
A-14	Module layout in cavity vessel (LANL 1997).....	A-18
A-15	Tungsten neutron source (LANL 1997).....	A-19
A-16	Target and blanket vertical section (LANL 1997).....	A-20
A-17	Low-energy beamstop (LANL 1997).....	A-22
A-18	Intermediate-energy beamstop layout (LANL 1997).....	A-23
A-19	High-energy beamstop (LANL 1997).....	A-24
A-20	Flow of Tritium Separation Facility processes (LANL 1997) .....	A-26
A-21	Isotope Separation System (LANL 1997).....	A-27
A-22	Helium supply system (LANL 1997).....	A-30
A-23	APT Cryogenics System (LANL 1997).....	A-36
A-24	SRS Tritium Facilities layout.....	A-42
A-25	Savannah River Site, showing waste management facilities.....	A-45
A-26	Low-Level Radioactive Waste Disposal Facility (E-Area).....	A-47
A-27	SRS waste handling processes .....	A-48

A-2

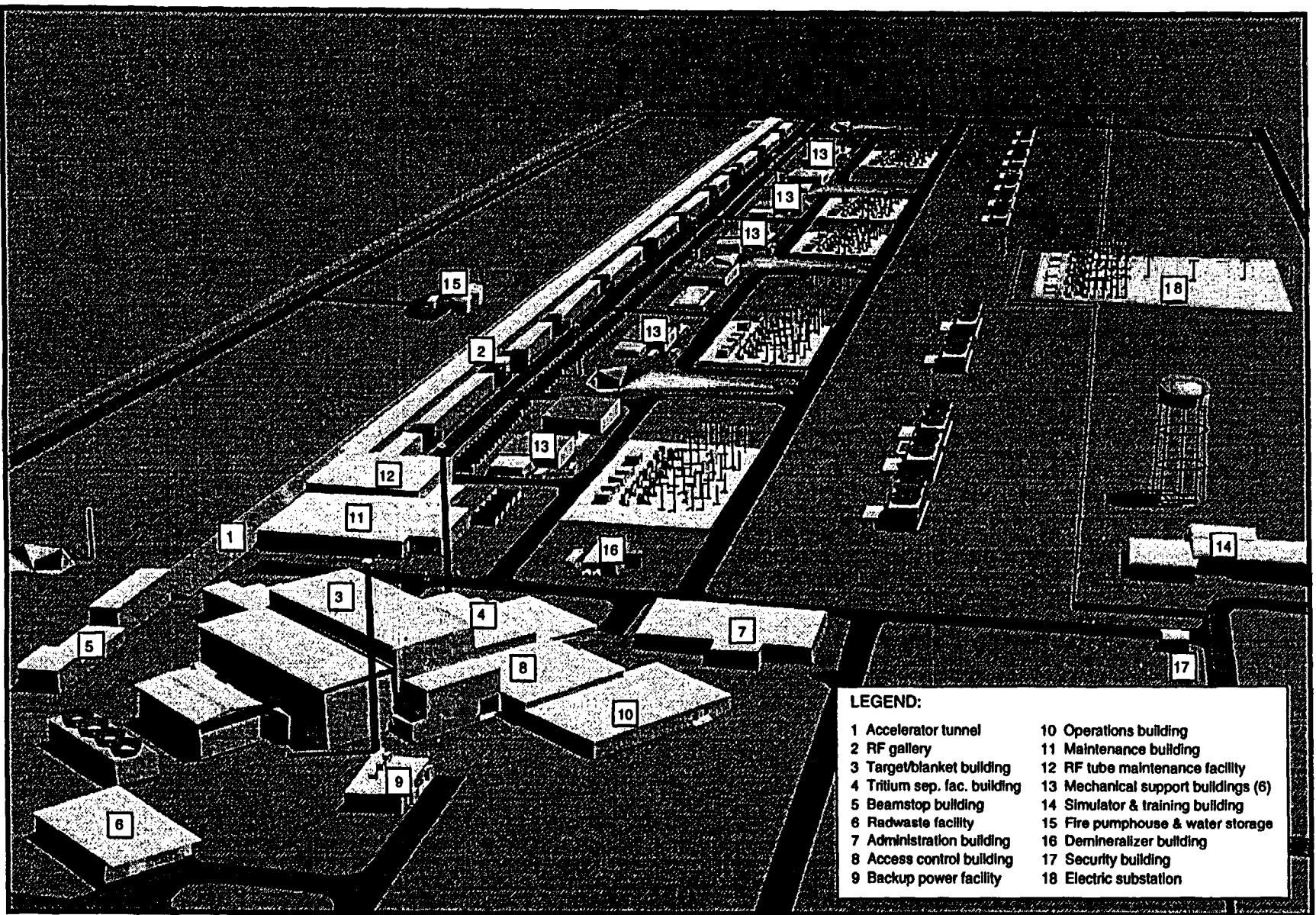

Figure A-1. Conceptual layout of APT facilities and structure (LANL 1997).

PK68-Z1-PC

### A.1.3 LOW-ENERGY (UP TO 100 MEV) LINEAR ACCELERATOR SYSTEM

The LE linear accelerator (linac) system would be the second section of the APT accelerator and would contain a radiofrequency quadrupole (RFQ) and a Coupled-Cavity Drift Tube Linac (CCDTL). The RFQ would capture the dc 75-keV 110-mA proton beam produced by the injector system, bunch it at 350 megahertz (MHz), and accelerate the bunched beam to an energy of 6.7 MeV. A CCDTL would accelerate the nominal 100-mA beam to 100 MeV.

The RFQ would be an 8-meter-long 350 MHz microwave structure containing four scalloped vanes arranged in a quadrupole geometry, which would provide strong radiofrequency (RF) focusing to the beam. The vane undulations in the vertical and horizontal planes would be 180° out of phase, producing a longitudinal RF accelerating field. The RFQ would be constructed in four 2-meter-long segments resonantly coupled together, with each segment assembled from two 1-meter sections. RF power would be fed to the structure through 12 coupling irises. The RFQ primary water cooling loops would remove the excess heat produced by the continuous wave RF losses in the vanes and cavity walls, and would regulate the cavity resonant frequency through temperature control. A manifold connected to three of the eight sections would provide vacuum pumping.

The Coupled-Cavity Drift Tube Linac would be a hybrid RF accelerating structure of short drift tube linac (DTL) sections that operates at a frequency of 700 MHz, and that alternates with quadrupole magnets for transverse focusing of the beam. The DTL sections would each contain one or two drift tubes, and would be resonantly chained together by side-coupling cells. The structure would combine the high-power conversion efficiency of the DTL in the low energy range with the high coupling strength and stability of a coupled cavity system. The quadrupoles would be external to the RF cavities, allowing easy access and positioning. RF power would be fed to the CCDTL segments using iris coupling, with each coupler handling as much as

250 kilowatts (kW). The quadrupoles would be arranged in an alternating focus and defocus (known as FODO) lattice with constant spacing in terms of  $\beta\lambda$ , the effective structure wavelength at a given beam velocity. The lattice period would be  $8\beta\lambda$ , where  $\beta$  is the ratio of particle velocity to the speed of light and  $\lambda$  is the free-space RF wavelength at 700 MHz. The CCDTL structures would be grouped in connected chains called supermodules, each powered by  $(n + 1)$  1-megawatt (MW) 700-MHz klystrons ( $n = 2$  to 6). The supermodule would act as a power combiner. Because only  $n$  RF tubes would be needed for operation, the extra unit would provide redundancy, enabling continued operation in case of a RF tube failure. Figure A-3 shows various configurations of the CCDTL and CCL. A manifold connected to each coupling cell would provide vacuum pumping.



### A.1.4 HIGH-ENERGY (GREATER THAN 100 MEV) LINEAR ACCELERATOR SYSTEM

The High-Energy Linac System would accelerate the 100-MeV 100-mA proton beam produced by the Low-Energy Linac to high energy (1,300 to 1,700 MeV) for delivery to the High-Energy Beam Transport and Expander System. There are two alternatives proposed for the High-Energy Linac: a room-temperature design that would continue the RF supermodule design used in the Low-Energy Linac with Coupled Cavity Linac (CCL) sections, and a multicell niobium superconducting (SC) radiofrequency design.

#### A.1.4.1 High-Energy Room Temperature Linac

The room temperature linac is based on CCL technology demonstrated at the Los Alamos Neutron Science Center accelerator. Figure A-4 shows the normal conducting linac system with a 2-kilogram tritium production level. A comparison of the room temperature system to the superconducting system, described in Section A.1.4.2, indicates that the linac layout and the

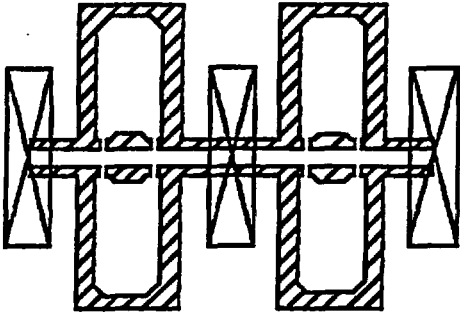
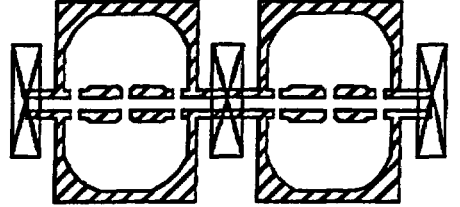
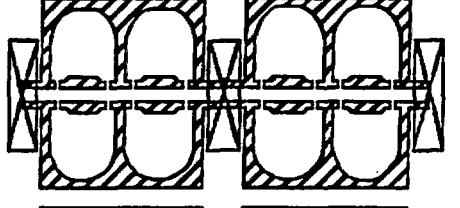

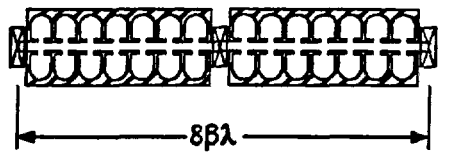
Structure Type	Accel. Gaps per Segment	Energy Range (MeV)
	2	6.7 - 8.0
	3	8 - 20
	4	20 - 100
	6	100 - 155
	7	155 - 217

$8\beta\lambda$

Figure A-3. Configurations of CCDTL (top 3) and CCL (lower 2) structures (LANL 1997).

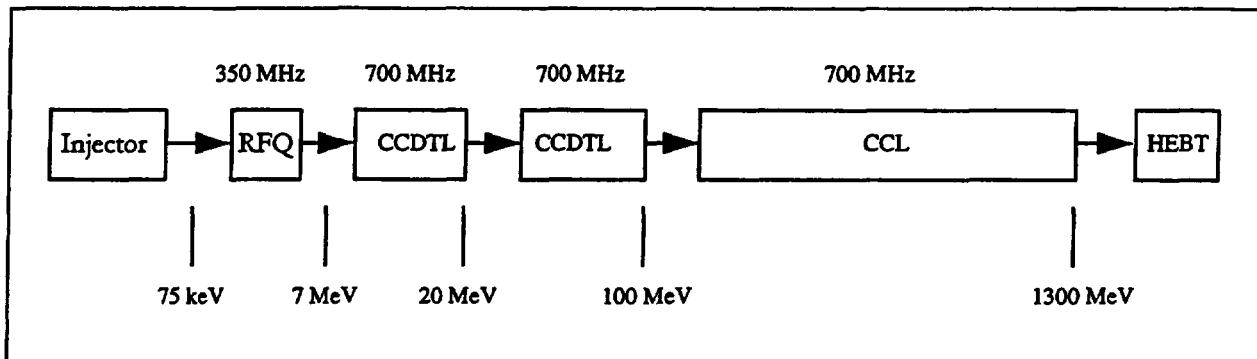

Figure A-4. Room-temperature linac system (2-kg production level) (LANL 1997).

structure types for the room temperature design would be identical to the superconducting radiofrequency (SCRF) design, except that the range of the last coupled-cavity linac structure type would extend beyond 217 MeV to 1,300 MeV.

The coupled cavity linac would be a conventional side-coupled RF linac, operating at a frequency of 700 MHz. The overall design concept would include short (six to seven cells) cavities, alternating with quadrupole magnets in a continuation of the  $8\text{-}\beta\lambda$  FODO focusing lattice of the CCDTL. The tanks would be resonantly coupled in supermodule configurations similar to the CCDTL, as shown in Figure A-3. Five 1-megawatt (MW) klystrons would drive each CCL supermodule; only four would be needed to maintain operation. As in the CCDTL, as much as 250 kW would be supplied at each drive iris. The average accelerating gradient would reach to 1.3 megavolts per meter (MV/m) in the CCL.

As in the CCDTL, the primary water cooling system would carry the excess heat from RF losses away, and would regulate the cavity frequency by controlling the water temperature. Cooling passages would be machined in the structure walls. Cavity shapes and parameters would be optimized to minimize RF losses for each energy region. The cavity lengths would increase in proportion to the increasing proton velocity. A manifold connected to each coupling cell would provide vacuum pumping.

Table A-1 summarizes the principal structures and functions used in the Room Temperature Linac System.

DOE could upgrade the system to produce 3 kg of tritium per year by beam funneling. Figure A-5 shows a funneled layout. Each side of the funnel would accelerate a beam of 67 mA in a 350-MHz bunch format. The current from both sides of the funnel would be combined at 20 MeV using an RF deflector that would

Table A-1. Room Temperature Linac System.

Factor	Structure Type						Totals
	RFQ	CCDTL-I	CCDTL-II	CCDTL-III	CCL-I	CCL-II	
Final energy (MeV)	6.7	8	20	100	155	1,300	1,300
Gaps per segment	-	2	3	4	6	7	-
No. of accel. gaps	433	48	177	600	378	5,243	6,879
No. of segments	4	24	59	150	63	749	1,045
No. of quadrupoles	-	25	59	150	63	749	1,046
Section length (meters)	8	5.0	16	81	51	1,000	1,200

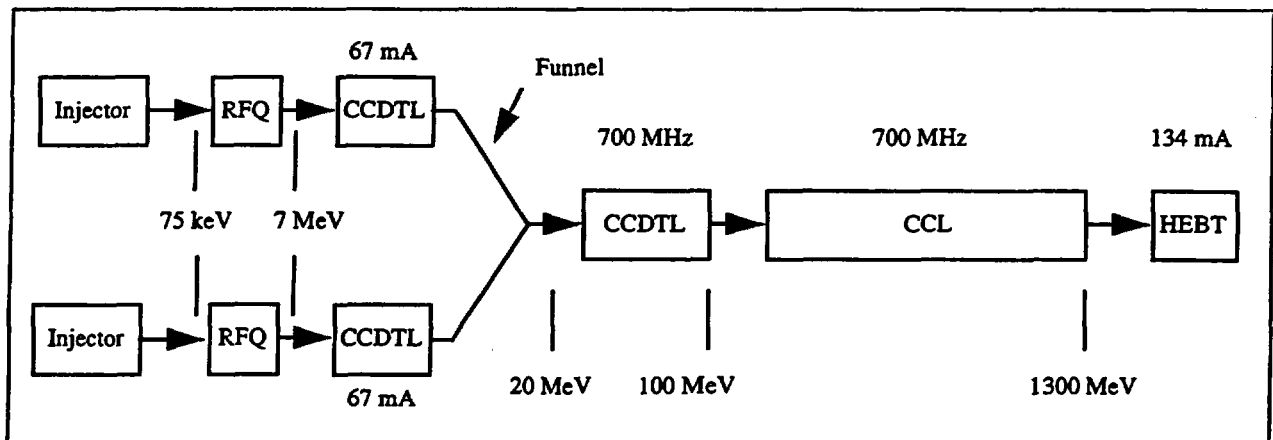

Figure A-5. Funneled Room-Temperature Linac System (3-kg production level) (LANL 1997).

interlace the beam bunches into a 700-MHz bunch format.

#### A.1.4.2 High-Energy Superconducting Radiofrequency Linac

Figure A-6 shows the Superconducting Linac System. The system would use a room-temperature coupled-cavity linac followed by two superconducting sections: a medium  $\beta$  section with identical cavities optimized for a velocity  $\beta = 0.64$ , and a high  $\beta$  section with identical cavities optimized for a velocity  $\beta = 0.82$ . Each superconducting section would consist of a sequence of identical cryostats containing superconducting cavities for acceleration and superconducting quadrupole magnets for focusing.

The CCL would be identical in principle to the CCL discussed in Section 1.4, except the final beam energy would be 217 MeV rather than 1,300 MeV. This means that the CCL for the superconducting alternative would be shorter and would use fewer tubes to supply RF power.

The medium  $\beta$  section would consist of a periodic array of 30 identical cryomodules, each consisting of a cryostat containing three five-cell superconducting accelerating cavities optimized for a beam velocity  $\beta = 0.64$ , and four superconducting quadrupole focusing magnets. The warm spaces between the cryostats would include beam-line valves, vacuum pumps, and beam diagnostics. The medium  $\beta$  section would accelerate the 100-mA proton beam

through a nominal energy range from 217 to 469 MeV with an average accelerating gradient ranging from 1.43 to 1.51 MV/m. The electromagnetic energy would be delivered to each cavity through two RF power couplers. The three cavities in each cryostat would be driven by a single 1-MW klystron through a series of power splitters.

The high  $\beta$  section would consist of a periodic array of 78 identical cryomodules, each consisting of a cryostat containing four five-cell superconducting accelerating cavities optimized for a beam velocity  $\beta = 0.82$ , and five superconducting quadrupole focusing magnets. The warm spaces between the cryostats would include beamline valves, vacuum pumps, and beam diagnostics. The high  $\beta$  section accelerates the 100-mA proton beam through a nominal energy range from 469 MeV to 1,700 MeV with an average gradient of 1.89 MV/m for the 3 kilogram per year tritium production rate. The electromagnetic energy would be delivered to each cavity through two RF power couplers. Adjacent pairs of cavities in each cryostat would be driven by a single 1-MW RF tube through a series of power splitters.

Superconducting quadrupole magnets would be installed between the RF cavities to provide transverse beam focusing. The magnets would supply the necessary integrated field gradient in the limited axial space available in the lattice. The fall-off of the magnetic field with distance from the quadrupole along the beam line would be sufficiently rapid to not interfere with the operation of the superconducting RF cavities.

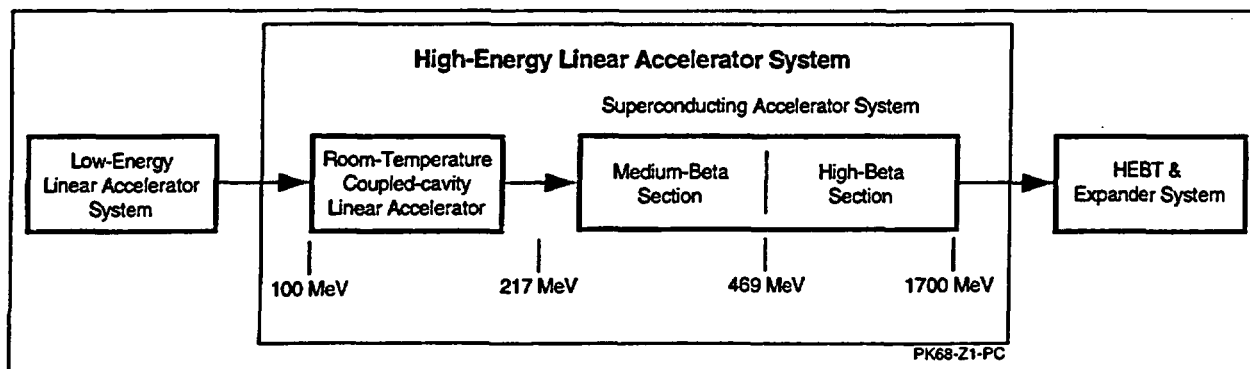

Figure A-6. Superconducting High-Energy Linac System (3-kg production level) (LANL 1997).

**A.1.5 HIGH-ENERGY BEAM TRANSPORT SYSTEM, SWITCHYARD, AND BEAM EXPANDER SYSTEM**

The High-Energy Beam Transport and Expander System would provide the interface between the High-Energy Linac System and the Target/Blanket System or the high-energy beamstop. Continuous wave (CW) proton beam currents of 100 mA and energies between 1,300 and 1,700 MeV would be transmitted to the target. Low-duty-factor beams from 100 MeV to 1,700 MeV would be transmitted to the beamstop during tuning. Figure A-7 is a block diagram of the system.

The HEBT System would transport the beam from the High-Energy Linac System to the switchyard. In addition, the HEBT System would provide diagnostics for measuring beam parameters as the beam emerged from the HE Linac System, correct beam steering errors, and would match the focusing lattice between the HE Linac System and the switchyard. The switchyard would direct the beam to the target/blanket through the beam expander or to the high energy beamstop line (which also would contain a beam expander). The beam expander would produce the large-area, uni-

form, rectangular beam intensity distribution required by the production target assembly. The beamstop line would transport the beam to the beam expander, which would provide a similar large-area beam footprint at the beamstop.

The HEBT System would consist of a FODO quadrupole focusing lattice with a cell length of 8 meters. This transport line would enable the longitudinal space-charge forces in the beam to lengthen the bunches while minimally affecting transverse beam parameters. In the first 28 meters of the HEBT System, the lattice would change from the 4-meter cell length at the end of the linac to the 8-meter cell length required in the switchyard. The HEBT System would contain beam diagnostics that would enable monitoring of such important beam parameters as beam position, current, profile, transverse jitter, halo distribution, and proton energy. It would also contain position monitor/deflector arrays to correct beam-steering errors and jitter.

Jitter is the small random rapid transverse beam motion that mechanical vibration of elements in the linac could produce.

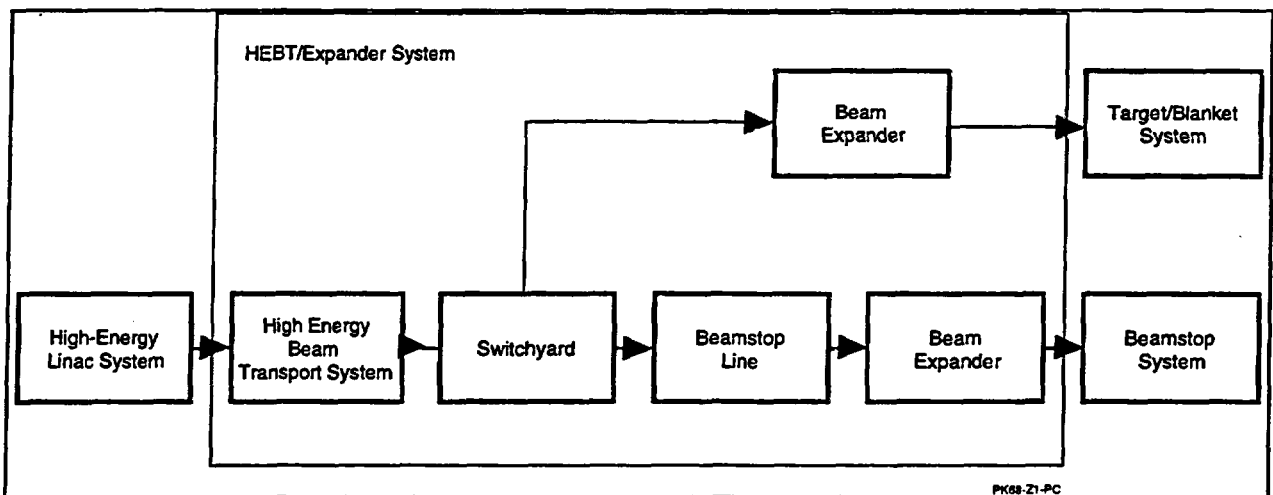

Figure A-7. High-Energy Beam Transport and Expander System (LANL 1997).

The switchyard, shown in Figure A-8, would contain the transport beamlines serving both the Target/Blanket assembly and the beamstop line. The beamline to the Target/Blanket assembly would begin with an achromatic bend consisting of 5 dipoles and 10 quadrupoles in a FODO lattice. Collimators at three locations of maximum dispersion in the achromat would intercept small amounts of off-momentum beam. The bending arc would contain beam diagnostics, including beam current monitors, beam position monitors, and beam loss monitors. A vacuum valve would be installed at the entrance of the arc. A tantalum beam plug would be installed with downstream shield walls and personnel fences so the beam expander serving the target would be accessible for maintenance when the plug was inserted and the arc dipoles were deenergized.

The beam expander subsystem would include the target beam expander and the upstream transport elements that matched from the 8-meter FODO cell of the achromatic bend into the expander. The beam expander section would contain nonlinear magnetic elements (octopole/duodecapole) and quadrupoles that would work together to transform the Gaussian-beam distribution in the transport line into uniform rectangular distributions. Expansion chambers downstream from the expanders would enable the beam to enlarge to a final 16-centimeter wide by 160-centimeter high rectangular footprint at the target/blanket or a 100-centimeter wide by 200-centimeter high footprint at the beamstop.

## A.2 Radiofrequency Gallery

The primary function of the Radiofrequency (RF) Power System would be to generate and distribute 350-megahertz (MHz) and 700-MHz RF power to the accelerating modules of the linear accelerator systems. Figure A-9 shows the system.

The RF gallery would extend the length of the injector and main acceleration tunnel sections and would be located adjacent to the tunnel

berm. The gallery would house the RF tubes and associated support components that would produce the radiofrequency waves to power the accelerator. The gallery would include the control panels, crowbar, high-voltage oil tank, and silicon-controlled rectifier (SCR) controller, and would accommodate the controls, cabling, and access required to operate and maintain the systems. Firewalls would divide the gallery into 10 zones. A 4.5-metric-ton bridge crane in each zone would facilitate servicing the RF tubes and associated equipment. Personnel would gain access from the gallery to the accelerator tunnel by elevators leading to the accelerator tunnel ramps.

An electrical crowbar is a protective mechanism that quickly places a low-resistance shunt across the output terminals of a power supply if a preset voltage limit is exceeded or if an uncontrolled discharge (arc/spark) is detected somewhere in the RF power system; its complete title is crowbar voltage protector.

The gallery would be a two-story structural-steel building about 1,220 meters long. The basement walls would be reinforced concrete. The above-ground building would be structural steel with metal siding. The second floor would be a poured-in-place concrete slab on structural steel with a total thickness of 0.8 meter. The waveguides would enter shafts in the basement that would connect to the accelerator tunnel. Shielding at the ends of each shaft would protect maintenance personnel in the gallery during operation. The shaft size would accommodate the removal of waveguides and equipment handling. Waveguide shafts would be prefabricated, reinforced-concrete sections.

The RF System would accept alternating current (ac) electric power from the power supply system, rectify and condition the power as direct current (dc), convert the dc power to RF power at 350 MHz and 700 MHz, and transmit the RF power to the linac accelerating structures. In addition, the system also would contain a number of control loops to ensure the delivery of

A-10

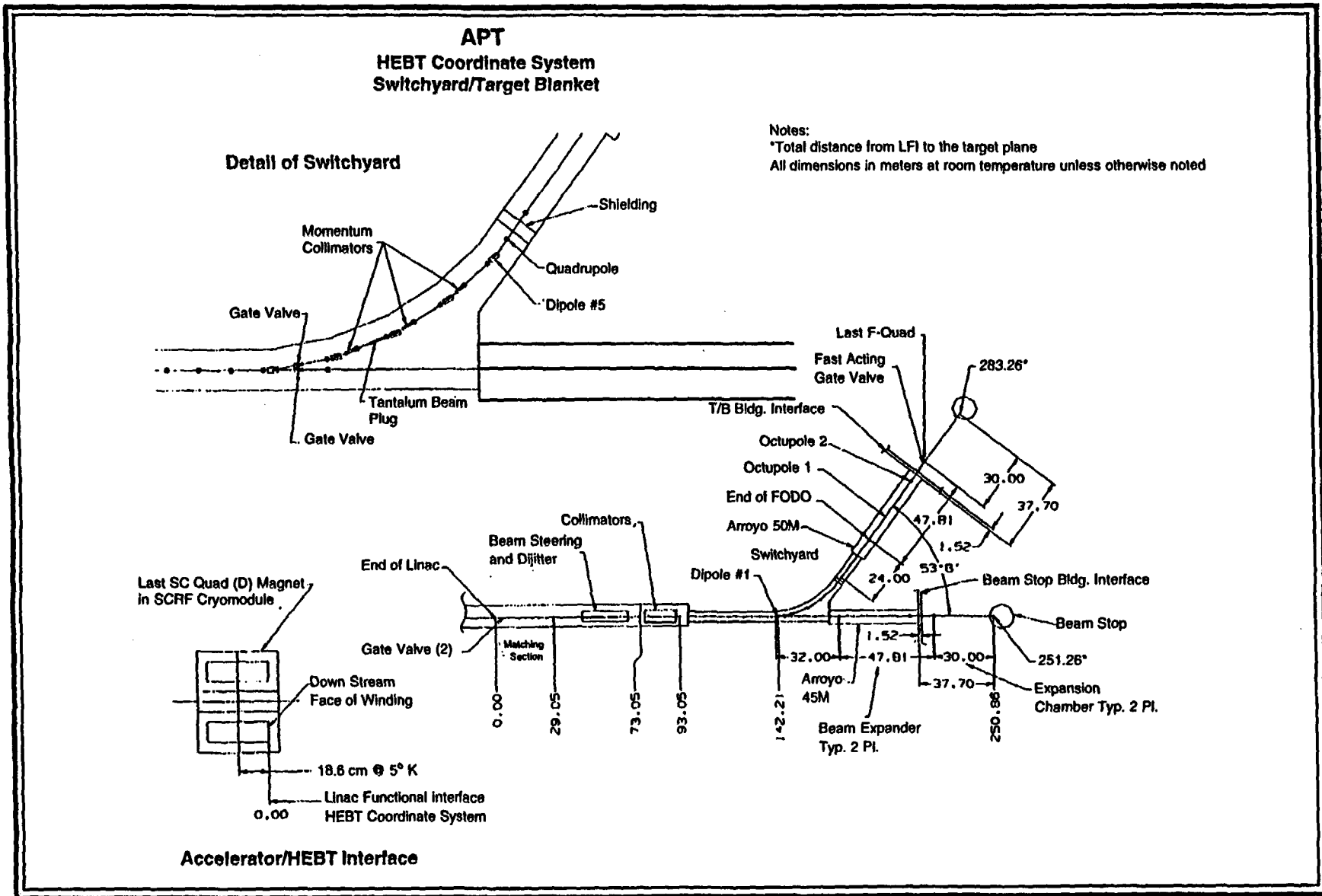

PK68-Z1-PC

Figure A-8. Switchyard (LANL 1997).

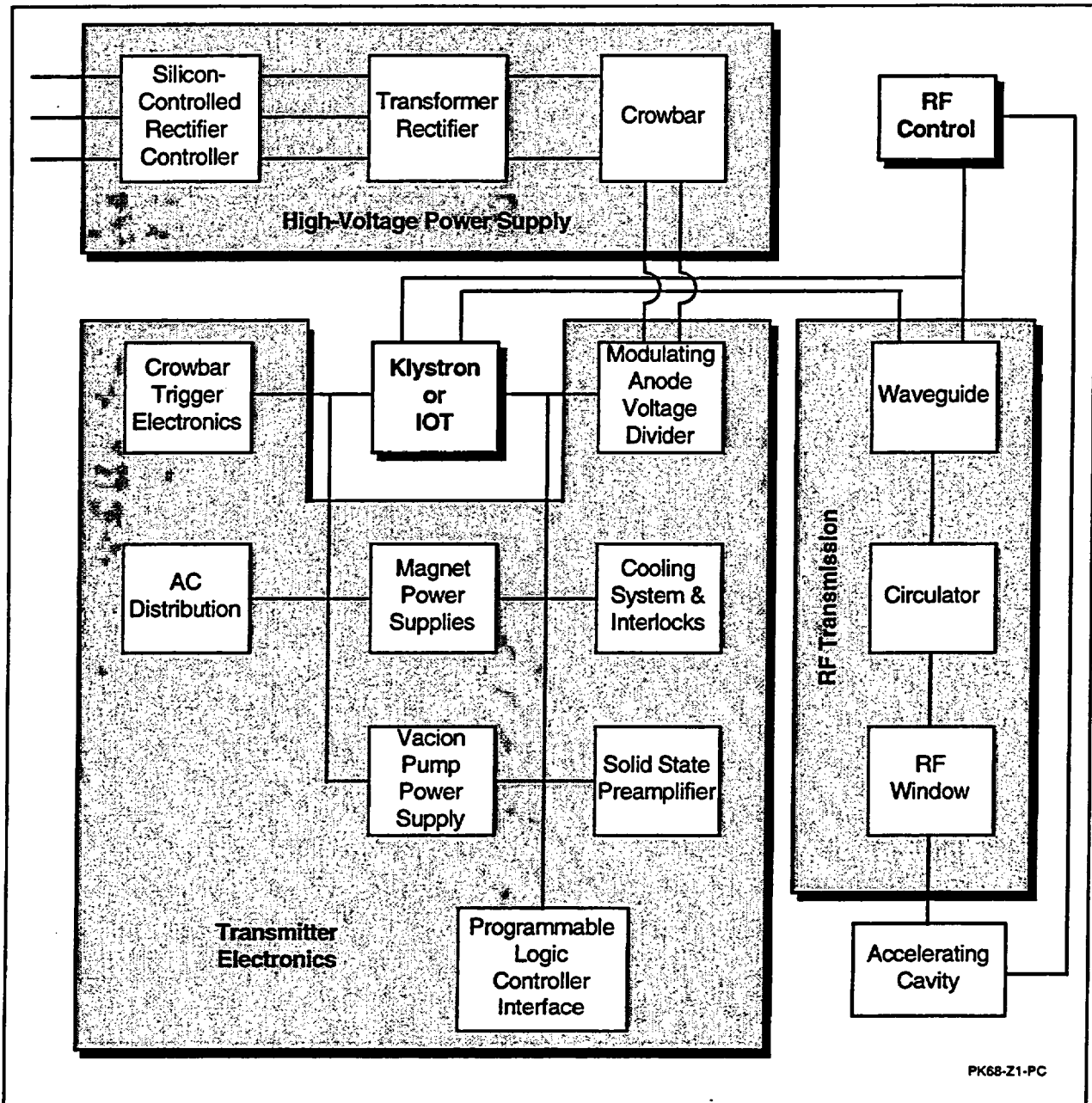

Figure A-9. Block diagram of RF Power System (LANL 1997).

RF power to the accelerating structures with the correct phases and amplitudes. The RF Power System would employ a similar architecture for all accelerating modules in the linac. There would be three 350-MHz RF stations, which would power the radiofrequency quadrupole; 234 700-MHz RF stations would power the superconducting linac design, while 270-700-MHz RF stations would be needed for the room temperature option.

Each RF power station would consist of the following subsystems: high-voltage power supply, RF tube, transmitter electronics, RF transmission, and cavity field/phase controls. The high-voltage power supply subsystem would include a high-voltage dc power supply, crowbar, and associated conditioning and support equipment for generating the electron beam in each RF tube. The RF tube subsystem would include the RF tube amplifier, which

would generate RF power from dc at the desired frequency, and a lead garage for x-ray shielding. The transmitter subsystem would contain the support electronics and power equipment for control of RF station components, with the exception of the high-voltage dc power supply; this subsystem would interface with the APT Integrated Control System (ICS) to provide control, monitoring, and operation of the RF Power System. The RF transmission subsystem would comprise the waveguide runs from the RF tube output windows to the accelerating structures, and would include the accelerating structure vacuum windows and the passive and active components needed to:

- Subdivide the RF power (splitters)
- Protect the RF tubes from mismatches (circulators, high-power loads)
- Isolate failed stations from the beamline (high-power switches)
- Provide phase adjustment (phase shifters) in the HE linac to compensate for beam energy changes
- Measure RF parameters (directional couplers) for input to the control loops

The cavity field/phase control subsystem would measure and regulate the RF field and phase transmitted to the accelerating cavities.

The RF Power System would use a separate high-voltage DC power supply for each RF tube. Each high-voltage power supply would require 1,500 volts ac as input, and would provide the RF tube a maximum of -95 kilovolts dc (negative polarity) power. Each amplifier would convert this dc power into a maximum of 1.2 megawatts of RF power for the 350-MHz RF systems and a maximum of 1 megawatt for the 700-MHz RF systems. The power stations would be in the RF Gallery building above grade. The RF output from each 1 megawatt station would be transmitted through a circulator to a waveguide that would penetrate the

earth berm into the accelerator tunnel. Inside the tunnel, the power would be divided into four or six equal feeds (by tiers of high-power splitters) so the power transmitted through each accelerating structure window and coupler would be held below 250 kilowatts, the maximum nominal operating level. In the low-energy linac and the high  $\beta$  section of the superconducting linac, the power would be split four ways (two tiers), while in the medium  $\beta$  section of the superconducting linac, the power would be split six ways (three tiers).

Cooling water or air would maintain the temperature of RF system components in both the RF gallery and the accelerator tunnel. Heat loads would include the power of the spent dc beams deposited in the RF tube collectors, RF power reflected to resistive loads, RF power losses in the walls of the RF tube bunching cavities, RF losses in circulators, waveguides, and switches, and power tube solenoid power and waste heat from power supplies.

#### A.2.1 KLYSTRON ALTERNATIVE FOR RF SYSTEM

As discussed in Section 2.3.1, DOE has identified two alternatives to supply radiofrequency power for the accelerator. The RF power tube known as the klystron is an established technology that has been used for years, and is the Preferred alternative. Section A.2.2 describes another alternative RF power device.

The 350-MHz RF system would be used only in the radiofrequency quadrupole. Three 1.2 megawatt klystrons would provide power for the RFQ; this would include one online redundant klystron, as only two of the three klystrons would be needed to supply sufficient power. Even if one of the three klystrons were not operating, there would be an additional 9 percent power reserve. Under nominal operation (i.e., all three 350-MHz RF systems operational) the klystrons would operate derated at two thirds of their design beam and RF power. Although this would lead to a slight decrease in efficiency, the operating life would increase, the



probability of klystron arcs would decrease, and there would be the added benefit of an online spare.

The 700-MHz RF systems would supply power to the linac system, providing a final beam energy as high as 1,700 MeV. The 700-MHz klystrons would have a maximum capacity of 1 megawatt (continuous wave). DOE selected this power level, in cooperation with klystron manufacturers, as the maximum power capacity achievable in a low-risk klystron development through an extension of the existing, well-known, continuous-wave klystron design.

The RF power system would include transmitters that would contain the klystron support electronics, RF system interlocks, interfaces to the accelerator control system, and devices known as circulators that would control the impedance that the klystron would drive, and would provide for safe disposal of power reflected from the accelerating cavity back towards the klystron. Circulators would be used in both the 350-MHz and 700-MHz systems.

The RF transmission subsystem, or power feed, would include the waveguides that would transmit the RF power from the klystrons to the accelerating cavities, as well as the circulators, power splitters, waveguide switches, and RF loads. After the circulator, the power from a single klystron would be divided into four or more equal parts using magic tees or hybrid waveguide power splitters. The power from the klystron would be divided to minimize the stress on the RF vacuum windows or on the couplers for the superconducting cavities at the accelerating structures. The RF power feeds would include arc protection.

Figure A-10 is an isometric view of the waveguide layout in the medium  $\beta$  high-energy linac portion of the accelerator tunnel for the superconducting alternative.

The radiofrequency supermodule -- a manifold-ing of klystrons to provide redundancy -- would be a major part of the RF system architecture design to support the linac requirements of high

availability and reliability. During operation and before an RF fault had been experienced, all klystrons in a supermodule would operate at six-sevenths of their maximum power output power. If a fault was detected, the RF system on the faulted unit would be disabled and the corresponding waveguide switch activated. The waveguide switch would serve two purposes: to connect the faulted unit to an RF load for evaluation, repair, and testing, and to reflect a short circuit at the appropriate phase back to the accelerating structure in order to not perturb the accelerating fields. Once the failed system was offline, the remaining systems would be returned to service.

The supermodule concept would enable rapid service restoration (5 minutes) in the event of an RF system fault. The failed component would be repaired offline and restored to service when convenient. This would enable the repair and test of the klystron and associated electronics in place, which would simplify maintenance activities and minimize the mean time to repair.

## A.2.2 INDUCTIVE OUTPUT TUBE ALTERNATIVE FOR RF SYSTEM

An alternative for generating RF power is known as an *inductive output tube* (IOT) system. An IOT would replace a klystron on a one-for-one basis and would provide the same basic output as a klystron.

The IOT has characteristics of both a klystron and a tetrode. Commercial IOTs are used for ultra-high-frequency (UHF) television broadcasts. The industry has developed a full line of multiple versions of IOT amplifiers for UHF broadcast, as well as continuous wave and pulse devices for such applications as the linear accelerator.

In a klystron, a continuous electron beam is accelerated through a high dc potential and then converted to a bunched beam through velocity modulation by a low-level RF signal. Electromagnetic energy is then extracted from the modulated beam in a resonant cavity through an

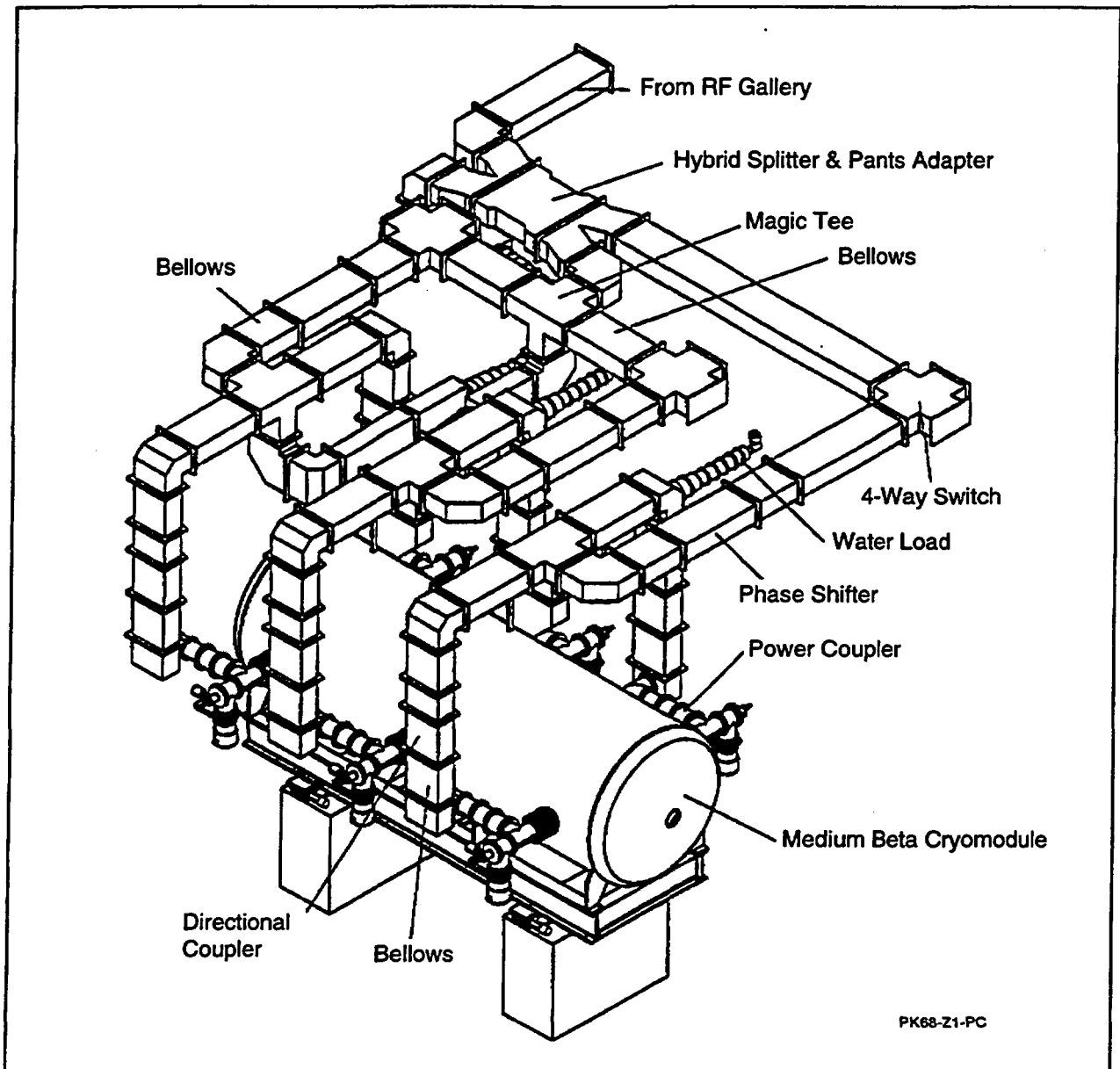

Figure A-10. Waveguide layout in the medium  $\beta$  HE linac (LANL 1997).

interaction gap. The spent electron beam is then dissipated in a separate electrode known as the collector.

When the klystron components necessary for reliable power-handling capability (specifically the output cavity and the collector) are combined with the grid-cathode components of a tetrode (which directly create a density-modulated electron stream), the result is the IOT. Figure A-11 is a schematic diagram of

one IOT design. The electron beam is formed at the cathode, density-modulated with the input RF signal by a grid, and then accelerated through the anode aperture. In its bunched form, the beam drifts through a field-free region and then interacts with the RF field in the output cavity. Power is extracted from the beam in the same way as in a klystron. The input circuit resembles a typical UHF power grid tube input circuit. The output circuit and collector resemble a klystron.

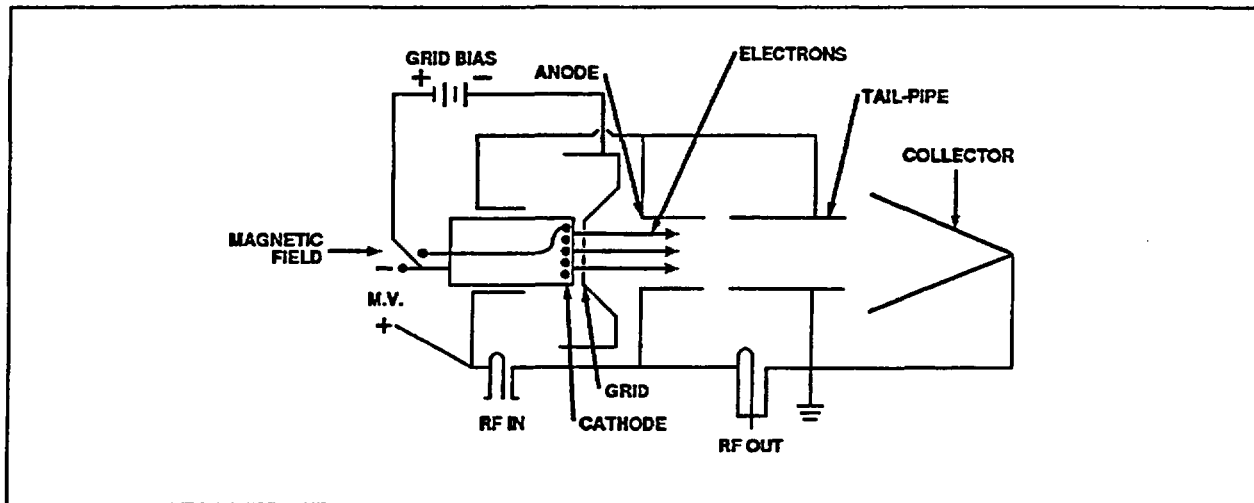

Figure A-11. Schematic diagram of an inductive output tube (Badger).

Two IOT devices have been investigated for use with a linear accelerator. Experience with these tubes has demonstrated that consistently higher (10-15 percent) efficiencies can be obtained while reducing the overall size of the power tube. For example, a 250 kilowatt IOT that is 1.2 meters long can generate the same power as a 6.1-meter-long klystron at the same frequency (Peters et al. 1994).

### A.3 Target/Blanket System

The target/blanket system would consist of the target/blanket assembly, the attendant heat removal systems, and beamstop system. The target/blanket assembly would produce tritium when impacted by the high-energy proton beam. The heat removal systems would safely remove the heat deposited by the proton beam during normal and off-normal conditions. Beamstops would be used during commissioning and occasionally during operation for beam tuneup. Figure A-12 shows the layout of the target/blanket building and the location of the heat removal systems and other major components in relation to the target/blanket station. The target/blanket would have primary and secondary heat removal systems and a tertiary system that would provide the heat sink.

#### A.3.1 TARGET/BLANKET STRUCTURE

The target/blanket structure would be same for both Helium-3 ( $\text{He-3}$ ) and Lithium-6 ( $\text{Li-6}$ ) feedstock materials. The target/blanket assembly would be in a concrete cavity approximately 20 meters square. Inside the cavity would be a large vacuum vessel that would house the target/blanket assembly. Outside the vessel would be steel and concrete shielding to allow personnel access to adjacent rooms while the beam is impacting the target. Figure A-13 is an isometric view of a target/blanket assembly. The components in the vessel would be modular, enabling remote and rapid replacement and maintenance.

The proton beam window would be a double-wall Inconel structure that separates the high vacuum beam expander from the rough vacuum target/blanket cavity vessel. The proton beam would lose only 0.2 percent in energy passing through the window. At the window position the beam spot size would be 13.4 centimeters wide by 144 centimeters high. By the time it reaches the tungsten neutron source 2 meters downstream of the window, the beam spot would expand to 16 centimeters wide by 160 centimeters high. The heat deposited in the

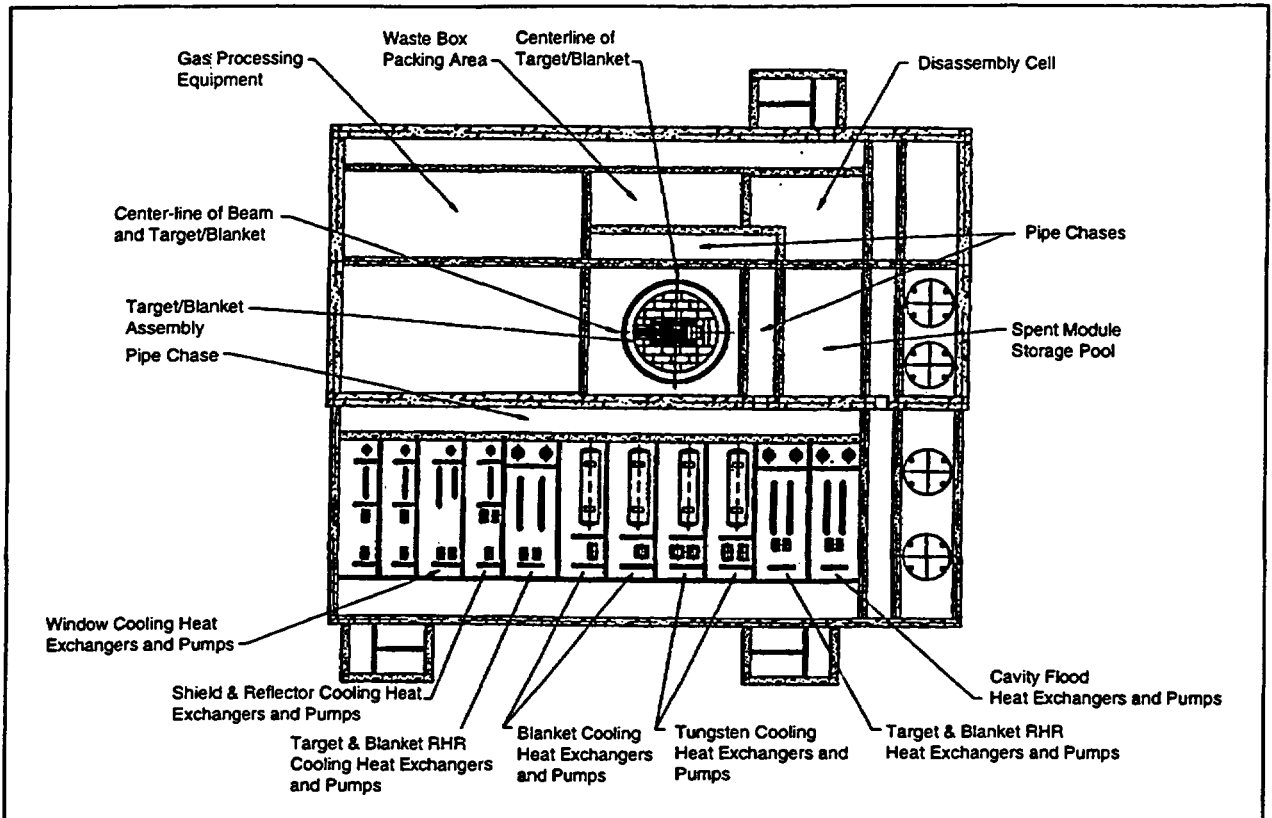

Figure A-12. Top view of Target/Blanket Building and heat removal systems (LANL 1997).

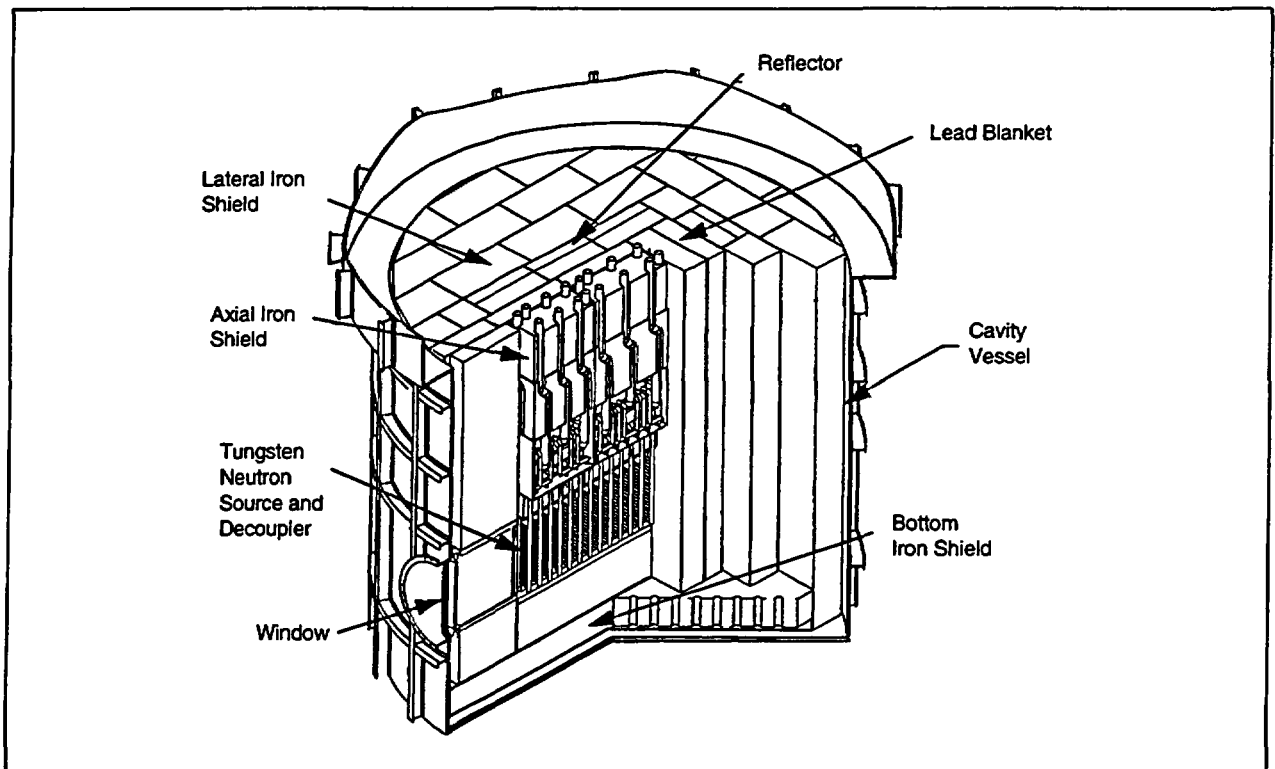

Figure A-13. Target/blanket assembly (LANL 1997).

window structure would be about 600 kW and would be removed by a low-pressure light-water coolant.

The proton beam would strike a centrally located tungsten neutron source that would be heavy-water cooled. The neutron source would consist of small Inconel-clad tungsten rods assembled in horizontal stainless steel tubes, and would produce neutrons and high-energy particles. The horizontal tubes would be manifolded into vertical inlet and outlet pipes with larger diameters, which would provide a coolant flow of heavy water at moderate pressure. The horizontal and vertical tube structure is called a ladder. The tungsten neutron source would consist of 13 such ladders separated into two modules, one containing six ladders and the other containing seven. Only 10 ladders would be used for the normal conducting alternative.

A blanket region would surround the tungsten neutron source and feedstock-containing decoupler; it would be approximately 120 centimeters thick and 350 centimeters high. The blanket region would contain lead, feedstock material (He-3 or Li-6), aluminum, and light-water coolant in fractions that would be optimized in specific regions to meet thermal-hydraulic safety margins while maximizing tritium production. Neutrons would be moderated to low energy by collisions in the lead and light water, and would be captured in the feedstock material in the blanket and decoupler to produce tritium.

The blanket would be surrounded by a reflector region similar in design to the last rows of blanket, except the lead would be replaced by light water. The reflector would reduce overall neutron leakage from the blanket and enhance tritium production. This region would consist of an aluminum housing, through which light water would circulate as coolant and reflector material, and blind aluminum tubes that would contain feedstock material.

The area between the window and the tungsten neutron source is called the upstream blanket region. The function of this blanket would be

to provide a channel through which the proton beam would pass while capturing neutrons back-streaming from the tungsten target. In addition, it would shield the upstream portion of the cavity vessel, reducing its activation. This 2-meter-long region would consist of a decoupler, a lead blanket, and a reflector, all of which would be light-water-cooled.

The downstream blanket region would be directly behind the tungsten neutron source. It would consist of a decoupler region followed by approximately 150 centimeters of blanket, similar to the lateral decoupler and blanket designs.

Iron shielding would surround the blanket and reflector to minimize activation of the vessel and external structures and to protect workers. In addition, the attachment of iron shields to the top of the target/blanket region would enable safe connection and disconnection of coolant and gas lines during module replacement operations. The first 100 to 200 centimeters of shielding that surrounded the blanket and reflector would require active cooling, which would be done with light-water cooling panels attached mechanically to the shield blocks. Outside this region the power density would be sufficiently low that active water cooling would not be required.

The upper vessel would house a number of structures that would provide the utilities required to operate the target/blanket modules. This would include headers for heavy-water and light-water coolant, connecting piping from the headers to the modules, instrumentation, the cavity flood inlet pipes, and the coolant circulation lines.

Encasing the target/blanket assembly and some of its shielding would be a sealed stainless-steel pressure vessel with a cylindrical shape and a removable head structure for access and extraction of internal components. It would provide a vacuum atmosphere through which the beam would pass, minimizing air activation. In addition, it would be the confinement boundary and radionuclide barrier in the event of an internal leak. In a cavity flood condition, the vessel

would be the pressure boundary for the flood coolant.

DOE would use a modular arrangement for the target/blanket assembly. For example, the tungsten neutron source would be combined with the decoupler and the first blanket region into two separate modules. Figure A-14 shows how 19 integrated modules would be formed. Each module would be available for separate removal and replacement. The window and neutron source modules are expected to require replacement every 1 to 3 years. The expected lifetime of the blanket modules is 3 to 10 years, and the outer blanket lead and reflector/shield modules are projected to last the plant lifetime of 40 years.

At the center of the target/blanket assembly would be two tungsten neutron source and decoupler modules, placed one in front of the other. These modules would be split to stay below the crane weight limit and to accommodate anticipated differences in lifetimes. Figure A-15 shows the tungsten neutron source ladder subassemblies, 13 of which would be equally spaced for increased neutron leakage, with an overall length of 3.76 meters. Each ladder would have multiple rungs containing bundles of Inconel-clad tungsten rods. Lateral rungs would be welded to vertical downcomers and risers to supply heavy-water coolant. The width of the ladder would be sized to keep the vertical risers outside the 16-centimeter beam width

with an additional 3 centimeters of clearance to the rung weld interface. The overall height of the ladder rungs would cover the 16-centimeter height of the beam along with an additional 10 centimeters of tungsten above and below the proton beam footprint. The top of each ladder would be welded to either an inlet manifold or an outlet manifold located well above the rungs.

### A.3.2 HELIUM-3 FEEDSTOCK MATERIAL ALTERNATIVE

High-energy particles scattered from the tungsten neutron source would leak into the surrounding blanket modules after passing through a decoupler region that surrounded the tungsten source. For the He-3 feedstock material, the decoupler region would consist of several rows of tightly packed aluminum tubes that contain He-3 with light-water coolant flowing outside the tubes under moderate pressure. The gas tubes would extend the full height of the ladder and would be connected to a manifold to enable continuous circulation to extract the tritium gas produced in the tubes. The He-3 in this region would preferentially absorb the low-energy neutrons that would scatter from the lead blanket toward the tungsten neutron source, thus maximizing neutron absorptions in He-3 and minimizing neutron absorptions in tungsten. A major fraction of the total tritium production would occur in the decoupler. Decoupler regions would be placed in the upstream and downstream blanket regions to enable high-

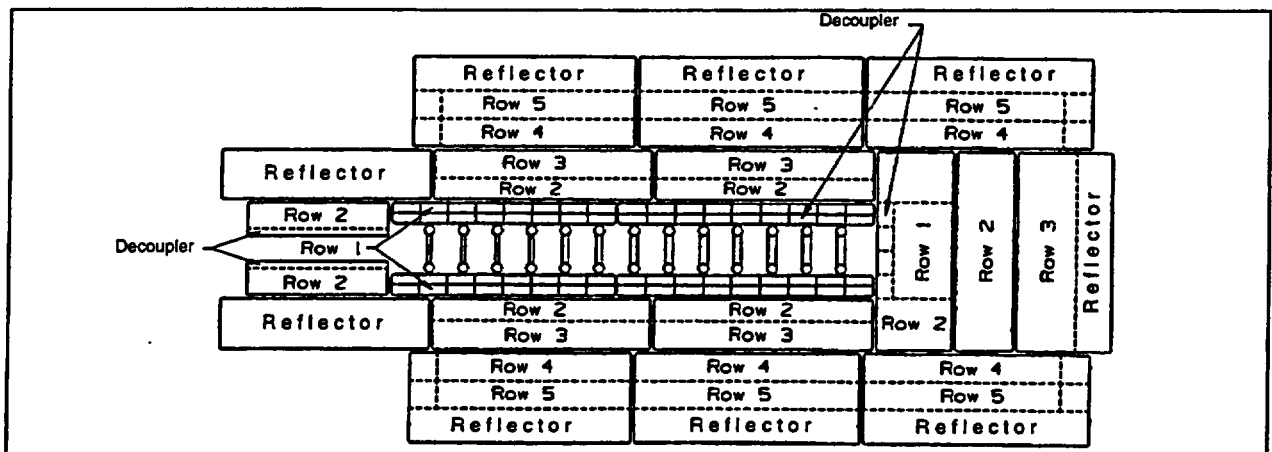

Figure A-14. Module layout in cavity vessel (LANL 1997).

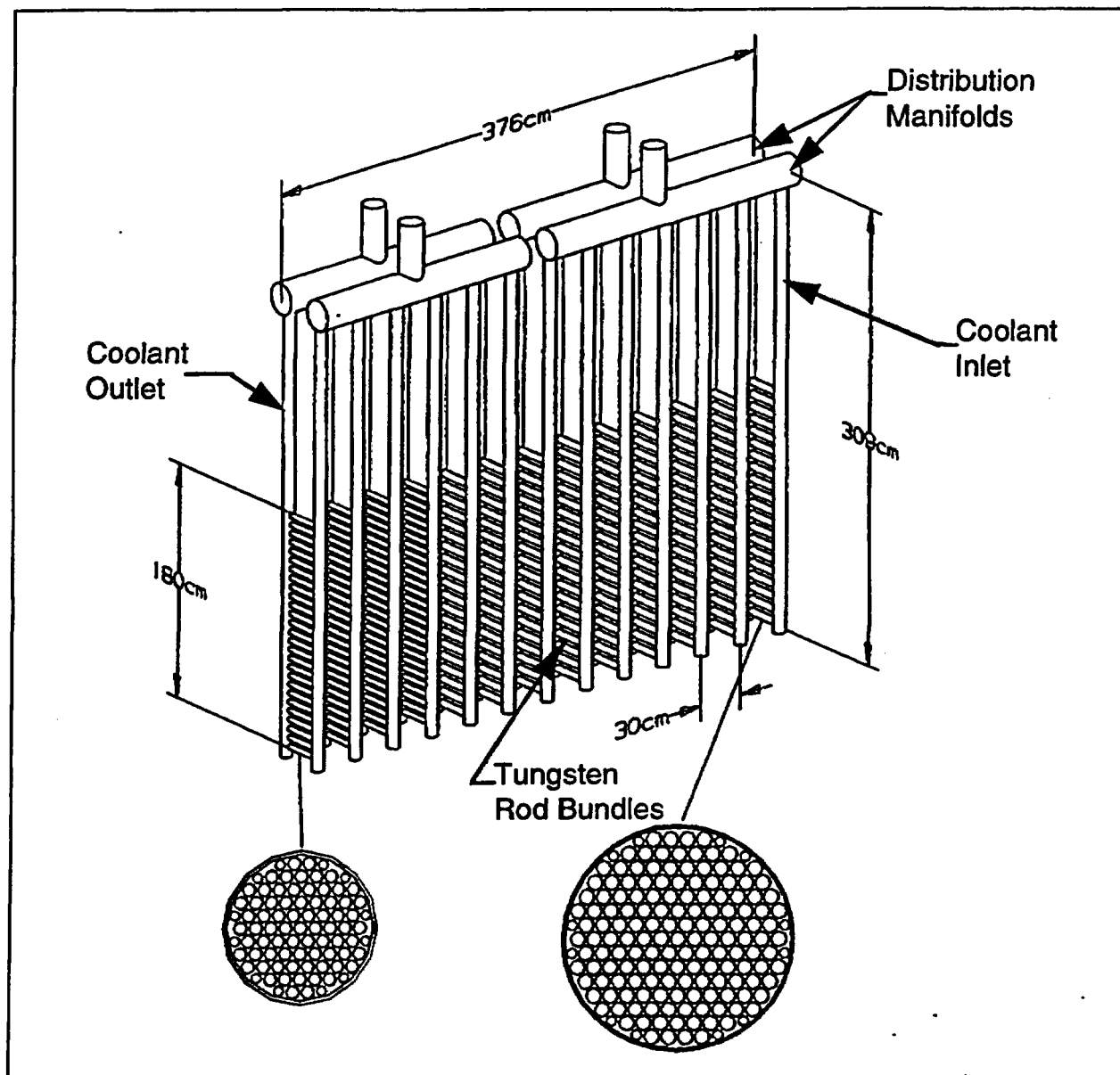

Figure A-15. Tungsten neutron source (LANL 1997).

energy particles to pass through and into the blanket, and to absorb any back-scattered low-energy neutrons in He-3 rather than the tungsten. Figure A-16 shows a vertical section of the target and blanket assembly configured for He-3 feedstock material.

The blanket lead would be cast into cruciform aluminum tubes to form rods. The He-3 would be in blind circular aluminum tubes (closed at one end) manifolded together at the top and sealed off at the bottom. The rods and tubes

would be assembled into aluminum housings that formed the pressure boundary for the light-water coolant.

The Gas Handling Subsystems would consist of the He-3 gas transport, cavity atmosphere, and low-pressure He-3 recovery. He-3 gas in the blind aluminum tubes in the decoupler, blanket, and reflector would produce tritium through neutron absorption. Tritium would diffuse through the static gas to headers that connected

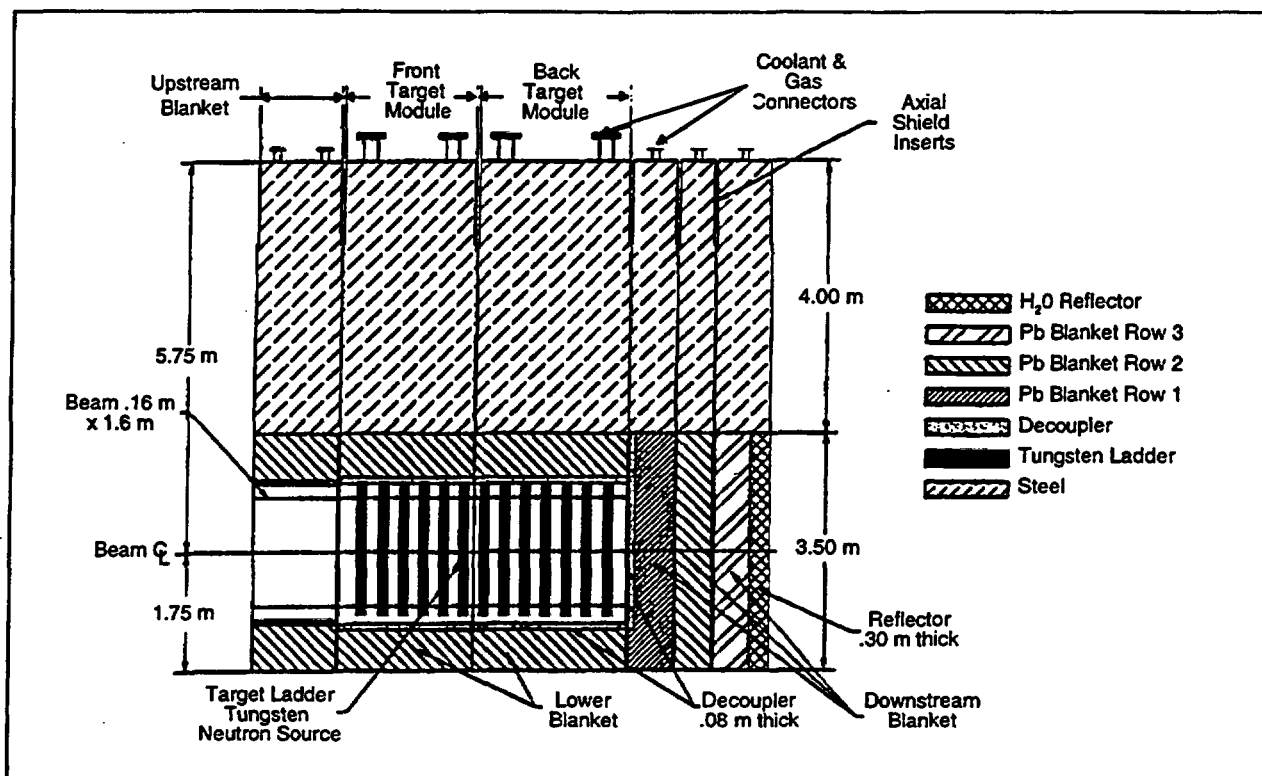

Figure A-16. Target and blanket vertical section (LANL 1997).

the tubes in a module. The Gas Handling System would maintain a continuous flow of gas through the headers. This system would transport the He-3 and tritium mixture to the Tritium Separation Facility adjacent to the Target/Blanket Building. Gas lines would be welded, with double-walled tubing between the modules and the Tritium Separation Facility gloveboxes. Gas from the modules would contain a mixture of He-3, tritium, other hydrogen isotopes, and impurities. After extraction of the hydrogen isotopes and the removal of impurities, pure He-3 would be returned to the Target/Blanket System modules.

A second gas subsystem in the Gas Handling System would control the cavity atmosphere during operation. This system would consist of a pumping system to evacuate the air from the vessel along with gas sensors and controls. The evacuated gases would be monitored continuously for indications of water ingress, He-3, hydrogen, or tritium gas. Controls would direct the gas flows to high-efficiency particulate air

(HEPA) filters, gas cleanup systems, a He-3 recovery system, or the stack.

The third gas system would be a low pressure He-3 recovery system that would collect the gas from many areas in the Target/Blanket Building and transport it back to the Tritium Separation Facility at the APT site. The recovery system would collect gases from the cavity vessel, coolant loops, vacuum line jackets, and gloveboxes in the Target/Blanket Building. Gases that could contain impurities could be processed to separate the He-3 and hydrogen isotopes from the contaminants to maintain a clean gas stream to the Tritium Separation Facility.

### A.3.3 LITHIUM-6 FEEDSTOCK MATERIAL ALTERNATIVE

Conceptually, the basic design of the Li-6 target/blanket module would be the same as that for the He-3 target/blanket assembly (Figures A-12 through A-13), except there would be no need for an adjacent Tritium Separation Facility.



The same aluminum tubes in the blanket and decoupler that contain gaseous He-3 in the He-3 Feedstock Material alternative would contain a solid aluminum-lithium alloy. As the feedstock material is solid, the accelerator would be shutdown to remove the feedstock material; the rods would be transported to the Tritium Extraction Facility for tritium recovery. As the tritium generated in the target/blanket module would only be removed at the end of an operating run (annually), all of the annual production of 3 kilograms would be present in the target/blanket structure. This is in comparison to the Helium-3 feedstock alternative which would have less than 100 grams of tritium present at one time in the target/blanket structure. The process for preparation of the Lithium-6 target rods is described in Section 2.3.3 of this EIS. Once the tritium is liberated from the lithium-aluminum matrix, the methods used to purify the tritium product are the same as for the Helium-3 Feedstock Material alternative.

#### A.3.4 BEAMSTOP SYSTEMS

The Beamstop Systems would include four types of beamstops, which would be categorized by energy level and as permanent or removable. The permanent beamstops would be used during commissioning and periodically thereafter for tuning the beam prior to full power operation. The removable beamstops would be used only for commissioning.

- **Permanent Low-Energy Beamstop.** This beamstop would be designed for a 20 MeV beam energy. It would be installed in the injector building to test the low energy portion of the linac, including the injector, radiofrequency quadrupole, and the first section of the CCDTL.
- **Permanent Intermediate-Energy Beamstop.** This beamstop would be designed for an energy of about 200 MeV. It would be installed in the tunnel at the room temperature/superconducting linac interface for the superconducting option or in the CCL

structure for the room-temperature alternative near 200-MeV.

- **Permanent High-Energy Beamstop.** This beamstop would be designed for energies between 500 MeV and 1,700 MeV. It would be installed at the end of the tunnel, and would be used for final beam tuning before plant start-up and restarts.
- **Removable High-Energy Beamstop.** This beamstop would be designed for energies between 500 and 1,500 MeV. It would be installed temporarily during construction at different stations in the tunnel to commission the high-energy portion of the linac. This requirement could be met with a single beamstop, which would be moved from station to station, or with a separate beamstop for each station. In either case, the beamstop(s) would be removed from the beamline at the end of commissioning and stored in a shielded area in an adjacent alcove or outside the tunnel.

##### A.3.4.1 Low-Energy and Intermediate-Energy Beamstops

The beamstops would be permanently installed in the facility. The low-energy beamstop would be used initially during the commissioning stage to test the low-energy range of the linac. The conceptual design for this beamstop consists of a single graphite plate under vacuum, positioned to intercept the proton beam. The graphite plate would be in an aluminum vacuum vessel, and would be supported and held in an incline angle of 20° from horizontal by a Carbon composite frame. The aluminum vessel would be 30 centimeters in diameter and 120 centimeters long. Stacked concrete blocks containing magnetite would be used for neutron and gamma shielding. The beamstop and shielding blocks would be sealed inside a metal enclosure that would be purged with Helium to avoid air activation. Figure A-17 shows the layout of the low-energy beamstop.

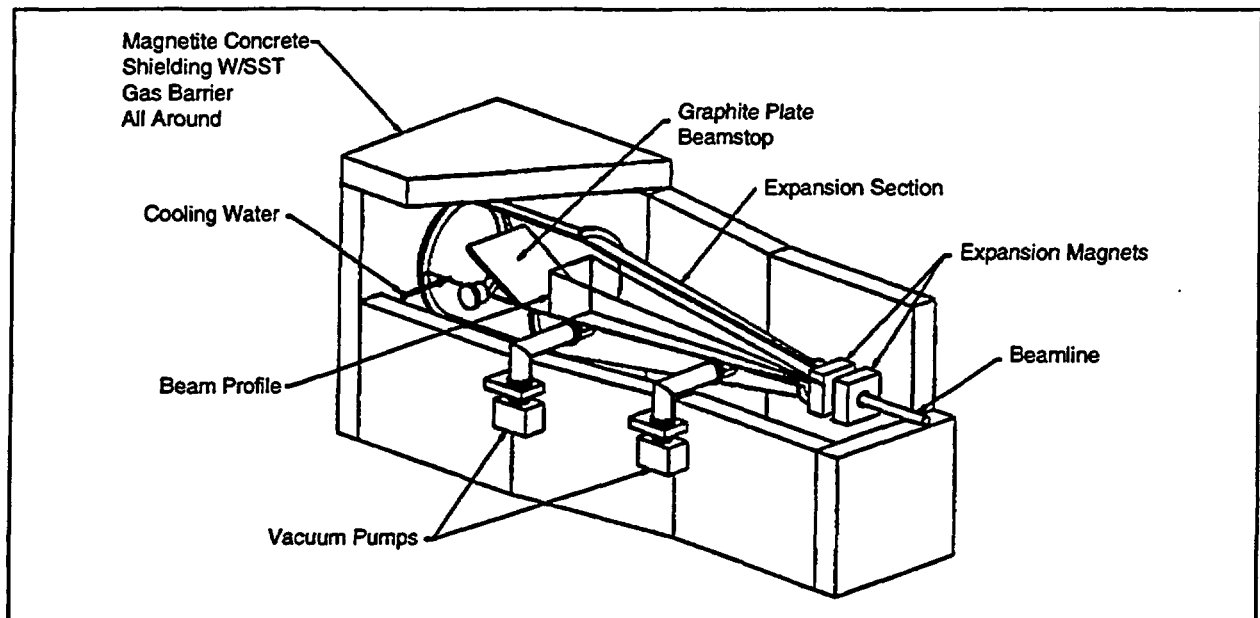

Figure A-17. Low-energy beamstop (LANL 1997).

The intermediate-energy beamstop would be placed permanently in the tunnel facility, and used extensively during commissioning. The conceptual design consists of a series of graphite plates mounted in a water-cooled vacuum enclosure. The design is similar to the low-energy beamstop but would be longer to accommodate as many as 6 plates. The beam energy would be absorbed in the plates and thermally radiated to the outer vacuum enclosure. Figure A-18 is a cross section view of the intermediate-energy beamstop.

The plates would be at an angle to the beam to reduce the reflection of thermal (IR) radiation from plate to plate and to help spread the IR energy to the vessel walls. The plates would be at a 45° angle to the beam with each at a 90° angle between plates. A typical plate size would be about 30 centimeters wide and 45 centimeters long. Because spacing of 10 centimeters between plates would be required, the total length of the plate string is about 305 centimeters.

Shielding of neutrons and gammas coming from the beamstop would be done with stacked concrete blocks that contain boron. The beamstop and shielding blocks would be sealed inside a

metal enclosure that is purged with Helium to avoid air activation.

For both beamstops, the vacuum vessel would be cooled by water cooling tubing integrated in the outer surface of the vessel. An aluminum-oxide spray coating would be applied to the inner surface of the vessel to increase surface emissivity, which would improve the absorption of thermal radiation from the graphite. Peak graphite temperature would range from 760° - 780°C.

#### A.3.4.2 High-Energy Beamstop

Three key differences in the high-energy beamstop requirements from those for the low- and intermediate-energy beamstops significantly affect the conceptual design:

- Proton energies would be higher and would require a longer target to stop the beam
- The duty factor would be 2 percent, a factor of 20 higher
- The beam profile would have a near uniform power density across the beamstop.

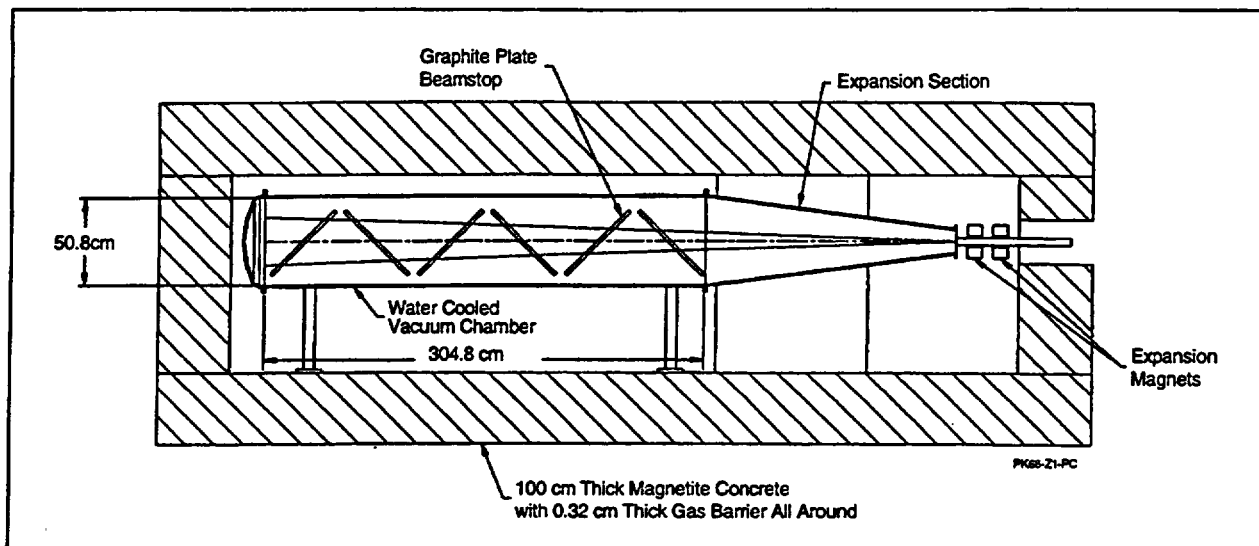

Figure A-18. Intermediate-energy beamstop layout (LANL 1997).

The beamstop would consist of five graphite modules of various lengths totaling 4.1 meters in overall length. The modules would be cooled by Helium that would pass through a series of slots in the modules running transverse to the beam. The coolant slot widths would vary from 0.85 to 1.5 centimeters, and the spacings between slots would vary from 4.3 to 8.0 centimeters. The end of module 5 has a 2.07-meter long section without slots because this region of the beamstop would not require direct cooling.

The slot widths and spacings would be set to maintain a maximum graphite temperature of 930°C at the midplane between coolant slots. This peak temperature would include a power peaking factor of 2.0, and would be considerably below the graphite vaporization temperature of 1,500°C.

The beamstop modules would be situated in an aluminum cylindrical vessel 1.8 meters in diameter. Fitted graphite blocks would occupy the space between the beamstop modules and the vessel. Commercially available water-cooled panels would be attached to the inner surface of the vessel to absorb heat transferred from the beamstop graphite surfaces through these blocks.

The Helium operating pressure at the inlet manifold inside the vessel would be set to 1.05

megapascal, which would be about equal to the vessel system pressure. By maintaining a low pressure differential between the vessel atmosphere and beamstop coolant, the potential for leaks from the coolant system would be minimized. The vessel would have a separate bypass vent line, as shown in Figure A-19, that could be used for purging the Helium tank and to monitor for leaks.

A beam window would be situated within the end wall of the pressure vessel. This window would have to withstand the 1.05 megapascal pressure differential and thermal loads. The conceptual design consists of two square plates of (aged) 718 Inconel about 30 centimeters on a side. The two plates would each be 1.3 centimeters thick and would be separated by 0.061 centimeter which would form a water cooling channel.

Each module would have a separate compressor or blower to supply coolant flow, and would have a separate heat exchanger. Both the compressors or blowers and heat exchangers would be at an accessible level well above the beamstop.

The specific shielding requirements, atmosphere enclosure method, and shielding cooling requirements for the high-energy beamstop would be developed in preliminary design.

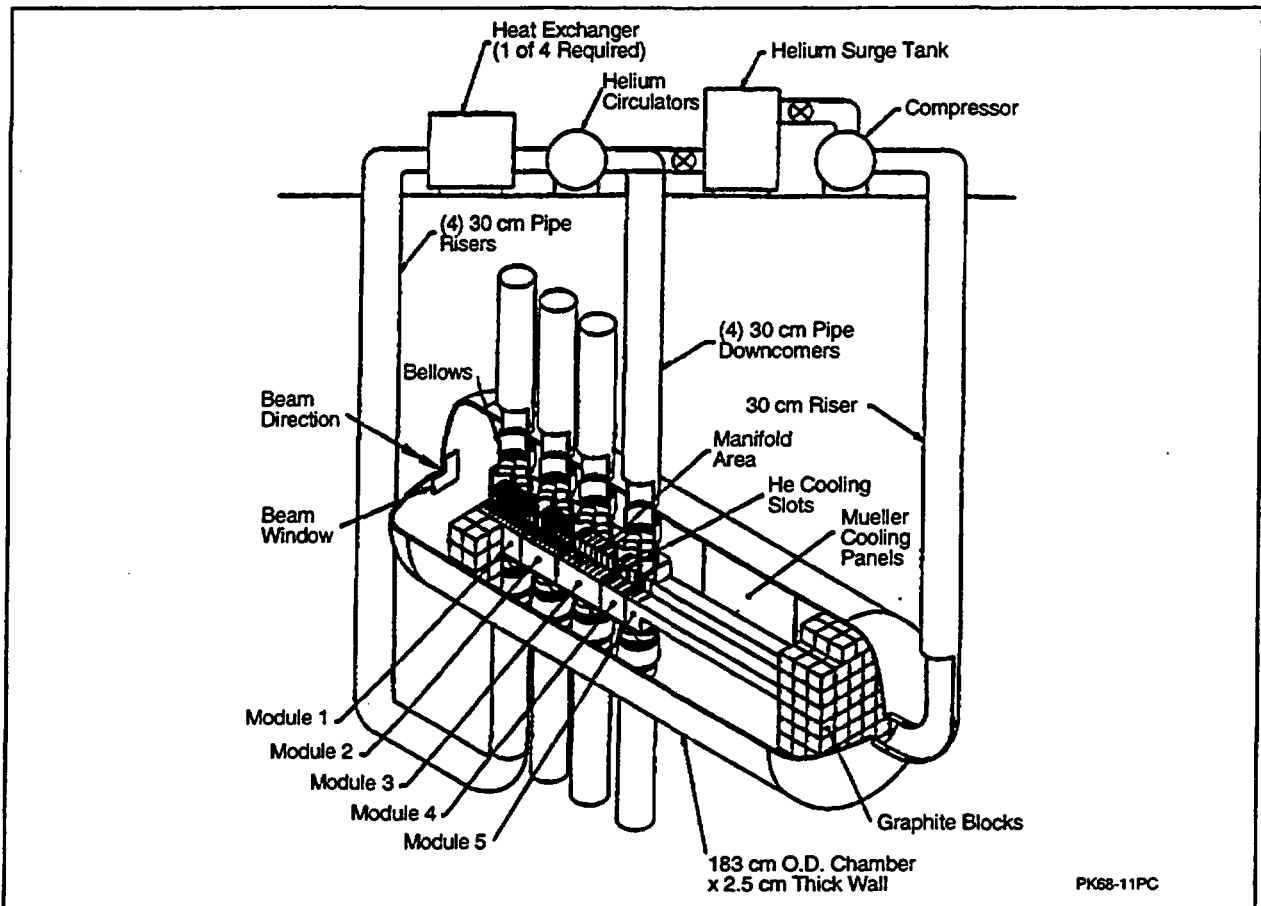

Figure A-19. High-energy beamstop (LANL 1997).

Low-energy operation would require a footprint for the beam in the beamstop that is larger than the one in the target. Thus, the design of the beam expander used for the target would be modified to give a 1-meter-wide by 2-meter-footprint in the beamstop. This would be done by increasing the drift space between the last quadrupole and the window to 30 meters and by changing the tuning of the last two expander quadrupoles.

#### A.3.4.3 Removable High-Energy Beamstop

The removable high-energy beamstop would be designed for proton energy levels between 500 and 1,500 MeV. This beamstop could be installed temporarily at different stations in the tunnel, or a separate removable beamstop could be installed at each location necessary for commissioning tests. It is expected that this beamstop will have a direct cooling system us-

ing Helium, similar in concept to that for the permanent beamstop. Because the beam profile is Gaussian, there will exist a large radial power gradient across the beamstop. This will require lower operating temperatures than in the permanent high-energy beamstop to achieve acceptable temperature gradients and thermal stresses.

Rapid removability would be provided. The current design would install the beamstop and its shielding on a carriage that moves on rails installed in the tunnel floor. For this design, the rails would be orthogonal to the beamline so that the beamstop could be retracted to a shielded alcove when no longer needed. Coolant lines connecting to the beamstop vessel could be routed using pipe chases incorporated within the carriage to external connections with the stationary support systems. Whether these

lines will be rigid or flexible will be determined in preliminary design.

Section A.5 describes heat removal systems for the Beamstop Systems.

#### A.4 Tritium Separation Facility

The Tritium Separation Facility (TSF) would extract and purify the tritium gas produced from the Helium-3 feedstock material. This facility would be at the APT site near the Target/Blanket Building, and would perform initial processing before shipping the tritium product to the SRS H-Area Tritium Facilities for final processing. For the Lithium-6 Feedstock Material alternative, tritium processing activities would occur at the Tritium Extraction Facility (TEF). The location of the TEF is being analyzed in the separate TEF EIS (61 FR 4670), but may include a location in H-Area or co-located with the Tritium Separation Facility.

The He-3 target process would use seven subsystems: the Tritium Extraction System, Isotope Separation System, Waste Gas Tritium Cleanup System, Tritium Storage System, Process Confinement System, He-3 Supply System, and Analytical Laboratory System. Figure A-20 shows the flow of these systems.

Hydrogen isotopes produced in the Target/Blanket System from neutron interactions with He-3 would be transported to the Tritium Separation Facility (TSF) through the Target/Blanket Gas Transport System circulation loops. A series of traps would remove potential spallation and activation products from the He-3 in the circulation loops before transfer to the TSF building. After removal of spallation products and other impurities, the gas stream would consist of hydrogen isotopes and He-3.

The extraction of the hydrogen isotopes from He-3 would use a palladium-silver *permeator*. Only hydrogen isotopes could permeate the palladium-silver, and they would be stored for further processing. He-3 could not permeate the palladium-silver and would recirculate

through the Target/Blanket Gas Transport System.

The resultant stored hydrogen isotopes would be separated into two product streams. *Cryogenic distillation* would produce a stream of high-purity tritium for processing and shipment to the SRS Tritium Facilities, and a deuterium/protium stream that would be less than 10 ppm in residual tritium would be released to the Tritium Separation Facility stack. Tritium emissions to the stack would be monitored to prevent exceeding environmental release limits.

To minimize the radiological risk to SRS personnel, the public, and the environment, tritium process equipment would be installed in a process confinement system that would use a recirculating nitrogen atmosphere. Tritium and He-3 released to the nitrogen atmosphere from process equipment or maintenance activities would be contained in the Process Confinement System; tritium would be removed from the recirculating nitrogen atmosphere and stored using a metal *getter* system.

##### A.4.1 TRITIUM EXTRACTION SYSTEM

The Tritium Extraction System (TES) would separate hydrogen isotopes from the He-3 stream received from the Target/Blanket Gas Transport System. The Tritium Supply System would contain multiple Tritium Extraction Systems which would interface with the TES network manifold in the Target/Blanket Building.

Each target/blanket module would have a line entering the glovebox, and modules would be grouped together based on tritium production. Valving would isolate individual modules or a group of modules in the event of a leak. The grouping of modules would minimize the number of piping runs between the Target/Blanket Building and the TSF building and the quantity of He-3 at risk. A series of heated metal getter beds and high-efficiency metal filters would remove impurities and spallation products from the He-3 stream for each line to the TES. One getter bed would remain in standby condition.

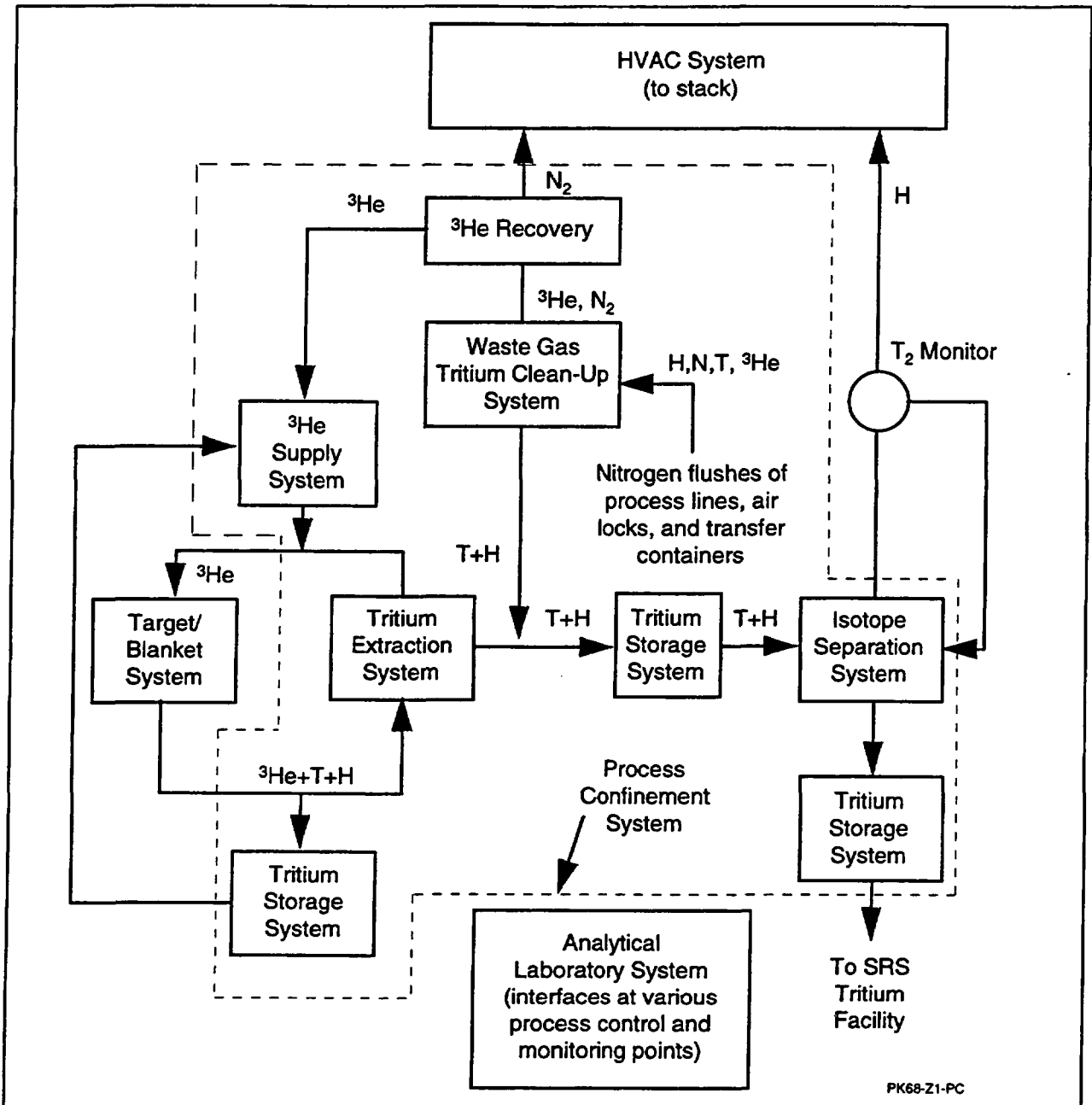

Figure A-20. Flow of Tritium Separation Facility processes (LANL 1997).

A series of *molecular sieve* beds would remove water from the Gas Transport System in the event of a leak into the system. Saturated *molecular sieve* beds would be collected for disposal or recovery of the water using a water recovery system. Operational flexibility would be provided to direct module groups to any of the TES gloveboxes in the TSF.

Each Tritium Extraction System network manifold would interface with two large double-walled storage vessels of the Tritium Storage System with a nominal storage capacity of 150 cubic meters. Each tank would provide emergency and shutdown storage for the Gas Transport System inventory of the Target/Blanket System.

The Tritium Separation Facility building would contain the Tritium Extraction System glove-boxes for removing hydrogen isotopes from the Gas Transport System. The He-3 stream would be directed through two palladium-silver membrane *permeators* in series. The palladium-silver membranes would be operated under pressure on the Gas Transport System side of the membrane and at high vacuum on the shell side. Hydrogen isotopes would selectively permeate through the membrane from the Gas Transport System side of the permeator to the high vacuum side of the membrane. Hydrogen isotopes that permeated to the shell side of the permeators would be pumped to metal hydride storage beds of the Tritium Storage System. The He-3 would be recirculated to the appropriate TES network manifold in the Target/Blanket Build-

ing and then to the appropriate target/blanket module grouping.

#### A.4.2 ISOTOPE SEPARATION SYSTEM

The Isotope Separation System would separate a high-purity tritium stream from an isotopic mixture of tritium, hydrogen, and deuterium, and would reduce the residual tritium concentration in the hydrogen waste stream to a level at which it could be sent to the facility stack without further processing. Two identical *cryogenic distillation* systems, connected in parallel and each capable of meeting the full facility demand, would be installed. Each system would consist of two or more sequential columns in combination with four catalytic equilibrators. Figure A-21 shows the Isotope Separation System.

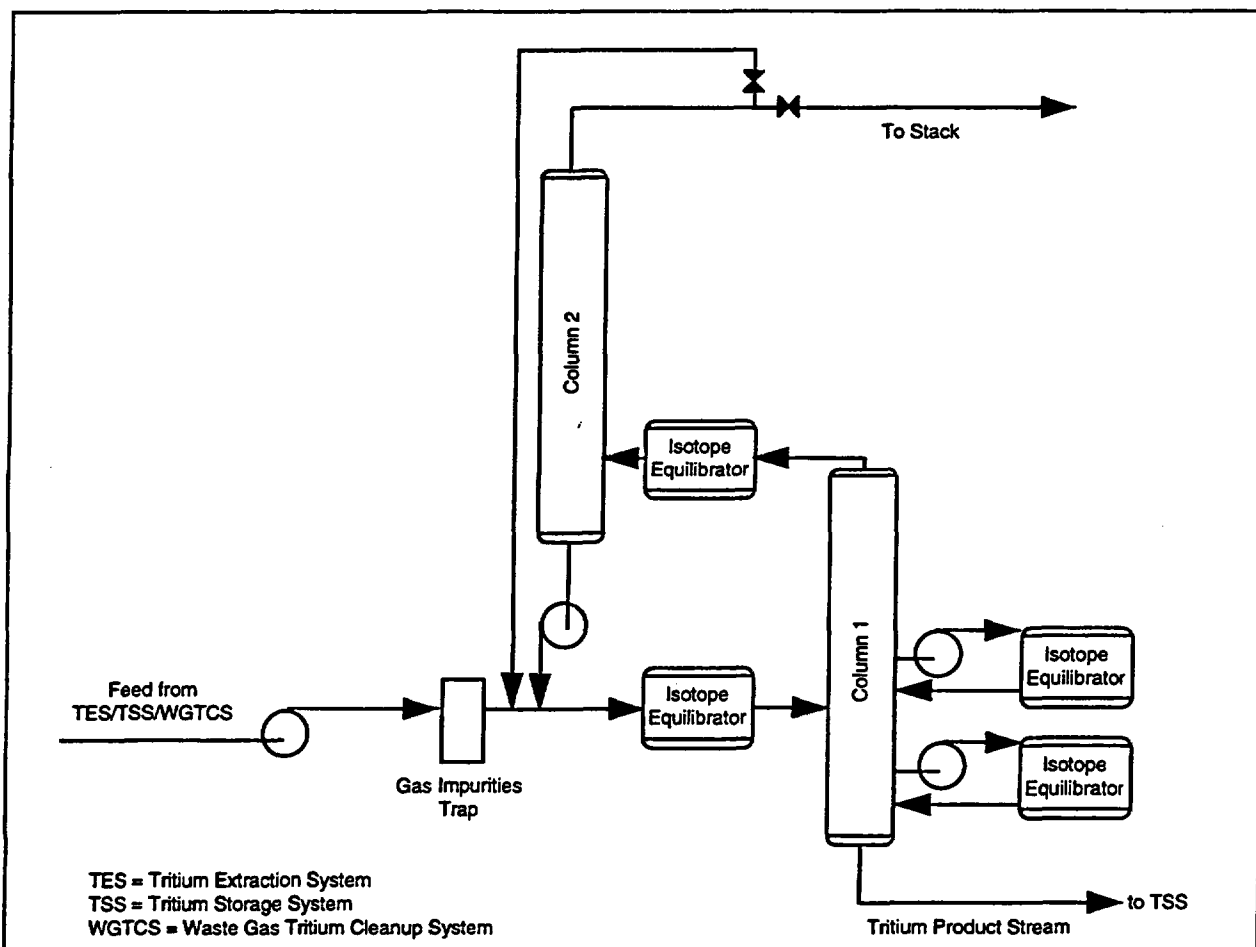

Figure A-21. Isotope Separation System (LANL 1997).

An anticipated gaseous stream of hydrogen, deuterium, and tritium would be fed to the Isotope Separation System either directly from the Tritium Extraction System or from the Tritium Storage System. First the feed would pass through a molecular sieve bed to trap gaseous impurities (e.g., nitrogen, oxygen, ammonia) that could have found their way into the feed during off-normal operating conditions and that would solidify and plug the distillation-columns. The purified stream would be combined with the bottoms product from Column 2 and passed through an *isotopic equilibrator*.

An isotopic equilibrator is a room-temperature reactor, packed with a palladium/aluminum catalyst that would partially convert the mixed isotopes HD (hydrogen-deuterium), HT (hydrogen-tritium), and DT (deuterium-tritium) to H<sub>2</sub> (hydrogen), D<sub>2</sub> (deuterium), and T<sub>2</sub> (tritium).

From the equilibrator, the stream would flow into Distillation Column 1, which would provide the principal tritium separation function for the Isotope Separation System, producing a tritium product stream. In the course of normal Column 1 operation, hydrogen would concentrate in the top of the column, tritium at the bottom, and HT in the center. To extract the tritium from HT (and the small amount of DT also present), two side-stream isotopic equilibrators similar in design to that described above for the feed stream would be used. A metal bellows pump would circulate the vapor through the catalytic reactor. The equilibrated vapor would be reintroduced into the column to effect separation. The distillate produced would consist primarily of H<sub>2</sub> and HD, with a residual T<sub>2</sub> concentration.

Distillate from Column 1 would be passed through a fourth isotopic equilibrator and fed to Column 2. The principal function of Column 2 would be to strip the residual HT, DT and T<sub>2</sub> from the stream so the final distillate could be sent to the facility stack without further processing. In addition, the second column would add flexibility to the overall design, enabling the Isotope Separation System to process feed

streams with off-normal compositions satisfactorily. Under off-normal conditions when the T<sub>2</sub> concentration exceeded 10 parts per million (ppm), the stream automatically would be diverted to the Waste Gas Tritium Cleanup System.

Each column would contain a pressure relief valve to vent the contents to a surge tank to protect against overpressurization. Vacuum in the jacket would be provided by a triode ion pump. Refrigeration to the columns would be provided by two Helium refrigerators rated at 100 watts. The refrigerators would supply Helium and would be plumbed to the two distillation systems in a way that enabled either refrigerator to provide cooling to either system.

Stream compositions would be monitored by appropriate instrumentation; ion chambers for monitoring tritium concentrations would be at the top of each column. If the tritium concentration in the distillate from Column 2 exceeded 10 ppm, flow automatically would be diverted from the stack to the Waste Gas Tritium Cleanup System. Each column would contain a pressure relief valve to vent the contents to a surge tank when the pressure exceeded 340,000 Pascal.

#### A.4.3 WASTE GAS TRITIUM CLEANUP SYSTEM

The Waste Gas Tritium Cleanup System would process tritium-contaminated nitrogen streams to remove hydrogen isotopes and recover He-3 before sending the nitrogen to the HVAC exhaust system. Tritium-contaminated nitrogen would be generated from the nitrogen flushes of process lines, airlocks, and transfer containers. Contaminated nitrogen streams would be stored in two 2,500-liter storage tanks. One storage tank would be the high-tritium-concentration receiver and would accept contaminated nitrogen streams from the evacuation of nitrogen flushes of process equipment. The second storage tank would be the low-tritium-concentration receiver and would accept contaminated nitrogen from nitrogen flushes of airlocks and transfer containers.



Tritium-contaminated nitrogen would be pumped from the receiver storage tank through a preheater and series of metal getter beds to remove the low levels of oxygen, moisture, ammonia, and methane that could be present in the gas stream. The removal of the gaseous impurities by the metal getter beds would be required to prevent a decrease in the capacity and efficiency of hydrogen isotope removal by the metal hydride storage beds.

The metal hydride storage beds of the Tritium Storage System would remove hydrogen isotopes from the tritium-contaminated nitrogen. The gas stream would be cooled passively between the metal getter beds and the metal hydride storage beds. Hydrogen isotopes would react with the heated metal, forming a metal hydride, enabling the nitrogen to pass through unreacted.

A flow-through ion chamber at the outlet of the series of metal hydride beds would measure the residual tritium in the gas stream. If the tritium concentration at the outlet of the metal hydride storage beds was sufficiently low, the gas stream would be sent to the Tritium Separation Facility HVAC exhaust system. However, if the outlet tritium concentration was high, the receiver tank and Tritium Separation Facility HVAC exhaust system isolation valves would be closed and the gas stream would be recycled through the cleanup system to further decrease the tritium concentration. If the tritium concentration fell below the cutoff limit, the TSF HVAC exhaust system isolation valve could be opened and the nitrogen sent to the exhaust system.

#### **A.4.4 HELIUM-3 SUPPLY SYSTEM**

The Helium-3 Supply System would provide a continuous supply of He-3 to the Target/Blanket Gas Transportation Subsystem at a constant pressure. The He-3 would be supplied by gas cylinders in the Tritium Separation Facility or from He-3 recovered from the Gas Transport System and other Tritium Separation Facility systems. The addition of approximately 1 percent hydrogen to the He-3 stream could

reduce tritium absorption on surfaces. Also, a fraction of a percent of a noble gas, such as argon, could be added as an online real-time tritium production monitor (i.e., the production of argon-41 in the gaseous stream could be detected relatively easily with radiation detectors, thereby serving as a tracer to indicate the relative production rate of tritium).

Pressure relief devices would be installed on all He-3 cylinders. Cylinders would be attached to the Helium Supply System manifold and secured in accordance with Occupational Safety and Health Administration (OSHA) guidelines. Check valves would prevent backflow from the Target/Blanket Gas Transport System circulation loop to the supply system. A low-pressure pump train would recover gas from the Tritium Separation System to the He-3 Supply System charge tank. A compressor would return recovered gas from the Tritium Separation System to the Target/Blanket Gas Transport System.

After a shutdown of a target/blanket gas circulation loop, the circulation loop He-3 would be diverted to large, evacuated Tritium Storage System storage tanks in the Target/Blanket Building. The He-3 would pass through a series of molecular sieve beds, getter beds, and filters to remove potential moisture, spallation, or activation products prior to storage in the tanks. The recovery of the gas would require pumping the gas from the storage tank to a charging tank in the Tritium Separation Facility with a scroll pump and metal bellows pump combination. Makeup He-3 would be provided to the Target/Blanket Gas Transport System by the gas cylinders. Figure A-22 shows the Helium Supply System.

#### **A.4.5 TRITIUM STORAGE SYSTEM**

The Tritium Storage System would consist of storage tanks for storing Hydrogen isotopes and He-3, and metal hydride beds for storing Hydrogen isotopes. Storage tanks would vary in size, depending on service function. The tritium stored on the metal hydride storage beds could be recovered as a gas by heating the beds.

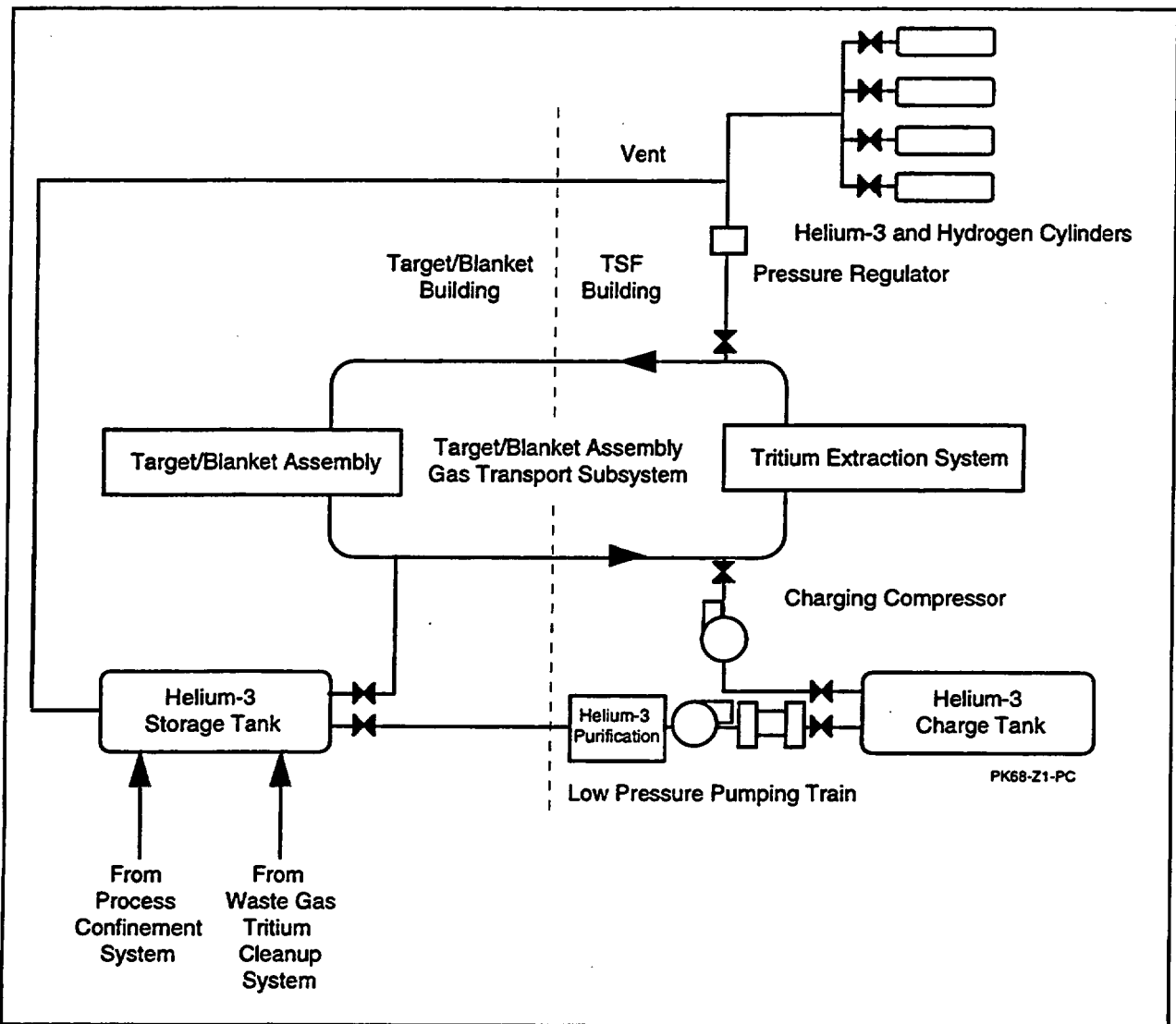

Figure A-22. Helium supply system (LANL 1997).

Tank contents could be sampled for analysis by the Analytical Laboratory System mass spectrometers via capillaries. Metal hydride storage beds would use an in-situ method of accountability to determine the quantity of tritium on each bed. In addition, the system would contain a manifold for loading tritium into metal hydride transport containers for shipment to the SRS Tritium Facilities.

Storage tanks external to the process confinement system gloveboxes would be double-walled vessels. Storage tanks inside the confinement system could be single-walled vessels. The metal hydride storage beds internal or ex-

ternal to the confinement system would be double-walled vessels. Each metal hydride storage bed would have two temperature controllers with automatic shutdown capability in case a heater fails.

The in-situ accountability method would incorporate calorimetry of the storage bed by comparing the tritium decay heat and equilibrium temperature of the storage container. Mass spectrometer analysis and pressure/volume/temperature measurements would determine gas concentrations in the storage tanks. Storage beds would store purified tritium product until the product was transferred to the loading

manifold. The gas would be transferred to a standard volume for analysis before loading into the storage container for shipment. A precision pressure gauge would be used to monitor the loading process.

## **A.5 Support Facilities at the Accelerator Site**

Several support facilities would be at or within the accelerator site. Section A.6 describes additional SRS support facilities elsewhere on the SRS.

### **A.5.1 APT SAFETY SYSTEMS**

Safety for the APT would be ensured because of the small releasable inventory of radionuclides. The APT design would provide multiple layers of protection to prevent or mitigate the unintended release of radioactive materials to the environment. Inherent safety features include:

- Use of conservative design margins and quality assurance
- Use of successive physical barriers for protection against release of radioactive material
- Provision of multiple means to ensure safety functions
- Use of equipment and administrative controls which restrict deviations from normal operations and provide for recovery from accidents to achieve a safe condition
- Safety systems designed to fail-safe on loss of power or motive force

The Integrated Control System (ICS) for the Accelerator, Target/Blanket, Tritium Separation Facility, and Balance of Plant would include multiple redundant sensors and diagnostics tied in to a central computer system. Operation of the APT plant would be accomplished from a centralized main control room with integrated

control system console groupings that would be able to operate major plant segments independently, concurrently, or decoupled from each other.

APT plant process systems, security systems, and other systems that would provide plantwide coverage, or local critical coverage, would be integrated into the overall operation of the main control room, but could be physically monitored and operated separately from the integrated control system. Even though operating console groupings would be primarily dedicated to operating a designated plant segment, all operating data would be accessible to anyone from any console with appropriate access control and security.

The main control room would be a part of a larger Operations Center which would be the termination point for safety systems, security systems, health protection and environmental monitoring systems, and any other systems that would provide plant-wide coverage or local critical coverage.

The ICS would include several subsystems to ensure positive control of accelerator systems. One of these systems, the Beam Permit subsystem, would provide a single signal which would enable the introduction of the beam into the accelerator. This system would be capable of monitoring and displaying to the operator the status of all signals forming part of the beam permit logic and would show clearly when and why beam would not be permitted.

Complementing the Beam Permit subsystem would be another subsystem known as the Fast Protect subsystem. This subsystem would be designed to protect accelerator equipment by turning off the beam quickly (i.e., a response time of about 5 microseconds) in response to a number of defined events or circumstances. This system would be independent of the main control system, although that system would be capable of monitoring the fast protect system, and, in the event of a beam trip, of identifying the originating event, or of analyzing a sequence of events. The result of a beam trip would be

to turn off the beam in the injector or low-energy beam transport section in such a way that it could be restored as soon as the offending condition was corrected.

The Radiation Monitoring and Protection System would consist of two main subsystems, the Target/Blanket Beam Shutdown (TBBS) System and the Radiation Exposure Protection (REP) System. The TBBS System would protect the plant from releases associated with the target/blanket and beamstop design basis accidents. This system would be designed to shut down or remove the beam from the target/blanket or beamstop before damage could occur that would result in a release above applicable safety evaluation guidance. The TBBS system would also initiate Cavity Flood and Residual Heat Removal systems, and would provide post-accident monitoring of the target, cavity, and residual heat removal operation.

The Radiation Exposure Protection system would be a monitoring and entry interlock system designed to keep personnel out of prompt radiation areas (e.g., the accelerator tunnel) when there is a possibility of measurable radiation exposure. The REP system would prevent beam transport if a beam spill were detected, or if an entryway door/gate were opened into a protected area that could lead to a prompt radiation hazard. A key control system would enable operations to control the access of personnel to protected areas.

Similar safety and control systems (primary and backup functions) would be designed into each functional part of the APT such as the low-energy and high-energy accelerators, the beam transport and switchyard devices, the RF power systems, the cryogenic systems for the superconducting alternative, and various accelerator support systems.

### **A.5.2 ADMINISTRATIVE BUILDING**

The Administrative Building would provide offices, conference rooms, lunchrooms, and medical support for APT management and staff personnel. This building would be inside the

secured area of the APT site. It would be a metal sided prefabricated steel structure.

Offices would be provided for managers, engineering, licensing, environmental, and procurement personnel. Support facilities in the building include a conference room, library, document control area, and a cafeteria.

### **A.5.3 ACCESS CONTROL BUILDING**

This building would provide facilities for controlling access to the Tritium Separations Facility building and the Target/Blanket building. It would house facilities to provide a controlled environment for health physics status monitoring for worker radiation protection, a badge security checkpoint, a dressing area to don anticontamination clothing, a radiation checkpoint, and an area for removing anticontamination clothing and performing personal decontamination. It would also provide space for storing health physics personal protection clothing, clean and used.

The Access Control building would abut the Target/Blanket Building, which would be between the Tritium Separation Facility and the Operations buildings. A passageway would link the Access Control Building with the Operations Building. An access corridor along the back of the facility would provide controlled entrance to the Tritium Separations Facility and the Target/Blanket building.

### **A.5.4 BACKUP POWER FACILITY**

This structure would contain three diesel generators to satisfy critical loads, uninterrupted power supply systems, and supporting equipment. Fuel tanks would have stairs to access and facilitate filling the tanks, and the diesel fuel area would be diked to contain spills.

One of the three generators would be rated for Production Support (PS) and the others for Safety Significant (SS). The facility would be a reinforced concrete building. The diesel generators would be in three separate rooms, with 3-hour firewalls between. A 1,000-gallon day

tank would be in each room. Dikes would surround the day tank, fuel line, and engine; the total volume of these dikes would be at least 1,000 gallons. The diesel and generator would sit on a 30-centimeter pedestal to keep spills away from the equipment. One 5,000-gallon storage tank would be provided for each diesel.

### **A.5.5 OPERATIONS BUILDING**

The Operations Building would provide office space, secure conference rooms, and a facility control room for the APT facility. It would include facilities and offices adjacent to the control room for shift supervision (first- and second-line, system and shift engineers, work control) and document clerks.

The main control room and the software development computer room would be reinforced concrete structures with 0.6-meter thick roof and walls. There would be a raised floor system in the control room and computer room. The main control room ceiling height would be at least 6.1 meters above the finished floor.

The Operations Building would be adjacent to the Target/Blanket and Access Control Buildings. It would have space to accommodate the main control room equipped with computers to monitor the systems involved in the tritium production process; computer software development; Integrated Control System shop and staging; spare parts and receiving workstation; library; conference room; and lunchroom/vending machines.

There would be a secured conference room for shift turnovers. A separate work area next to the storage/receiving and Integrated Control System shop areas would house a work control/package release area and a printing area. There would be offices for maintenance personnel and 13 work control stations. The main control room would have a mezzanine that would be a viewing area to observe APT operations.

### **A.5.6 MAINTENANCE BUILDING**

The Maintenance Building would be a one-story building. It would house elements for maintenance, APT instrument and equipment calibration, and assembly and disassembly activities.

The configuration of the facility would be based on the following elements: maintenance machine shop; tool crib area; welding area with loading dock access; two clean room storage areas with loading dock access; instrumentation work bench/test bed and staging area; Level B storage; Level C storage; electrical work bench/test bed and staging area; computer stations; conference room; lunchroom with kitchen area; and men's and women's locker rooms. Office space would be provided for maintenance supervisors.

The structural system would be a preengineered shop-fabricated rigid steel frame superstructure with reinforced concrete footings and a reinforced concrete slab on grade floor. There would be a secondary structure on which to hang the building's ceiling system and to adequately support doors, windows, and mechanical and electrical systems. Perimeter walls would be insulated metal siding with an insulated standing seam metal roof.

### **A.5.7 RF TUBE MAINTENANCE FACILITY**

The RF Tube Maintenance Facility would enable the remanufacture of one RF tube every two days. This building would be linked to one end of the RF Gallery to simplify handling of RF tubes requiring maintenance. The facility would consist of 10 stations, each of which addressed a unique aspect of repair. The station arrangement would enable a sequential progression of RF tube remanufacture and minimal distance between stations. The facility would have the following spaces:

- RF tube receiving area, adjacent to the RF Gallery

- Disassembly area
- Cutting area
- Inspection/cleaning area
- Assembly area
- Welding area
- Baking area
- Connections area
- RF tube testing area
- RF tube storage area

There would be additional space for the supervisor's office, conference room, break room/vending machine area, consumable storage area, supply room, mechanical room, electrical room, and restrooms with showers and changing areas.

The layout of the building would accommodate RF tube support vehicles, which would straddle and lift the RF tube for transport. Additional features in the RF tube receiving, testing, and storage areas would include bridge cranes, roll-up doors for RF tube import and export, and a temperature-controlled environment.

#### **A.5.8 MECHANICAL-DRAFT COOLING TOWER STRUCTURES**

One alternative for cooling of APT components is through the use of mechanical-draft cooling towers. If this alternative were selected, the vendor-provided fiberglass mechanical-draft cooling tower structures would be installed over reinforced concrete catch basins. A pumping structure at one end of the basin would support the circulation pumps. Cooling tower systems would be provided for the Tritium Separations Facility, accelerator, RF tube cooling stations 1 through 9, cryogenics facilities 1 through 3, RF Tube Maintenance Facility, target/blanket heat removal, and beamstop heat removal. These structures would be placed on the APT site near the facilities where they would be used.

Typical cooling tower structures will remove between 10 and 60 megawatts of heat energy using 2 or 3 cells in each cooling tower. Makeup water for the cooling towers could originate from groundwater on the APT site or from the SRS River Water System (see Sec-

tion A.6.5). As discussed in Chapter 2, DOE has also evaluated alternatives using once-through cooling with river water from the Savannah River and using the K-Area cooling tower (see Section A.6.6) in conjunction with the River Water System.

#### **A.5.9 MECHANICAL SERVICES BUILDINGS**

These six facilities would house components for HVAC and heat removal, such as circulation pumps, heat exchangers, water chillers, expansion tanks, and pressurization pumps. Primary heat exchangers of cooling water systems associated with components in the accelerator tunnel would be enclosed in concrete structures to provide radiation shielding. In addition, a breathing air system would be located in one of the mechanical services buildings.

#### **A.5.10 SIMULATOR AND TRAINING BUILDING**

The Simulator and Training Building would be outside the security perimeter, at the target end of the APT site, so new employees could receive initial orientation, occupational training, and environmental safety and health training while awaiting site access. In addition, it would contain a visitor center to enable members of the public to learn more about the APT facility.

This building would have space for the simulator control/operator's training area, computer software development area, classrooms, auditorium with a movie projection screen, conference room, training personnel offices, visitor's mezzanine, and lobby.

#### **A.5.11 FIRE PUMP HOUSE AND WATER STORAGE TANKS**

The Fire Pump House would be a reinforced-concrete masonry structure with reinforced-concrete spread footings and slab on grade floor. The pump house would have space for electric and diesel-driven fire pumps. It would be large enough to accommodate equipment

and components, and provide access for maintenance.

All necessary electrical equipment would be in this building, with a firewall separating it from the diesel pumps. The diesel and electric pumps would be in areas of the building separated by a 3-hour firewall.

Water storage tanks would be above-ground storage designed in accordance with National Fire Protection Association Publication 20. The water storage tanks would be collocated with the fire pump house.

#### A.5.12 DEMINERALIZER BUILDING

This would be a structural-steel building with reinforced concrete spread footing foundations and slab on grade floor. It would provide space for the caustic storage tank, unloading pump, and metering pumps; acid storage tank, unloading pump, and metering pumps; cation exchangers; degasifiers; anion exchangers; mixed bed polisher; after filters; storage tanks in diked areas with rain cover; and a water laboratory.

#### A.5.13 SECURITY BUILDING

The Security Building would be a reinforced masonry or concrete structure with heating and ventilation facilities, located at the security fence line at the target/blanket end of the APT site. Facilities would be provided to control admittance to the plant and monitor personnel exiting the plant. It would have space for the control counter to monitor the security fence perimeter and facility control points; portal monitoring control system for radiological boundary screening prior to the APT site exit; office and records storage area; and entry control systems (metal detectors, etc.) required by DOE Order 5632.1C.

#### A.5.14 CRYOGENICS SYSTEM

If DOE chose the Superconducting Operation alternative, it would construct a *cryogenic* facility at the APT site. The APT Cryogenics System would supply the necessary cryogenic fluids to

maintain the high-energy linac cryomodules at the correct operating temperature. The system would provide liquid Helium for the five-cell superconducting cavities, for the superconducting quadrupoles and their current leads, and a stream of Helium gas to provide thermal shielding of these components (within the cryostat) from ambient temperature. Figure A-23 shows the planned cryogenic system configuration.

The system would have a refrigeration capacity of 15.9 kilowatts which would cover the estimated heat load for 1,700-MeV linac operation with a 50 percent margin. The cryoplant design is based on the cryoplant now in operation at the Thomas Jefferson National Accelerator Facility in Newport News, Virginia. The APT site would require three cryoplants, each with a refrigeration capacity of 7.6 kilowatts. During normal operation each cryoplant would operate at nominal 74 percent capacity (67 percent, plus 7 percent for system stability). In case one plant shut down, the redundancy of the system would enable the high-energy linac to continue operation at about 1,500 MeV after a short period (i.e., a few minutes) to retune the accelerator.

For 1,300 MeV high-energy linac operation, two cryoplants could supply refrigeration with about 20 percent capacity margin.

Because of the high cost of Helium gas and the relatively low cost of providing storage tanks, DOE would provide sufficient capacity to store 80 percent of the operating inventory of Helium in the gaseous state. Each of the three cryoplants would have six 30,000-gallon propane tanks for this purpose. The gaseous storage tanks would operate at 1,700,000 Pascal, which would be slightly below the discharge pressure of the warm Helium compressors, 2,000,000 Pascal. A typical large-size horizontal propane tank in use at national laboratories would hold 30,000 gallons, with each tank about 15.8 meters long and 2.4 meters in diameter. The tank would be connected to the compressor package by control valves to enable makeup gas to be provided as needed to the first-stage

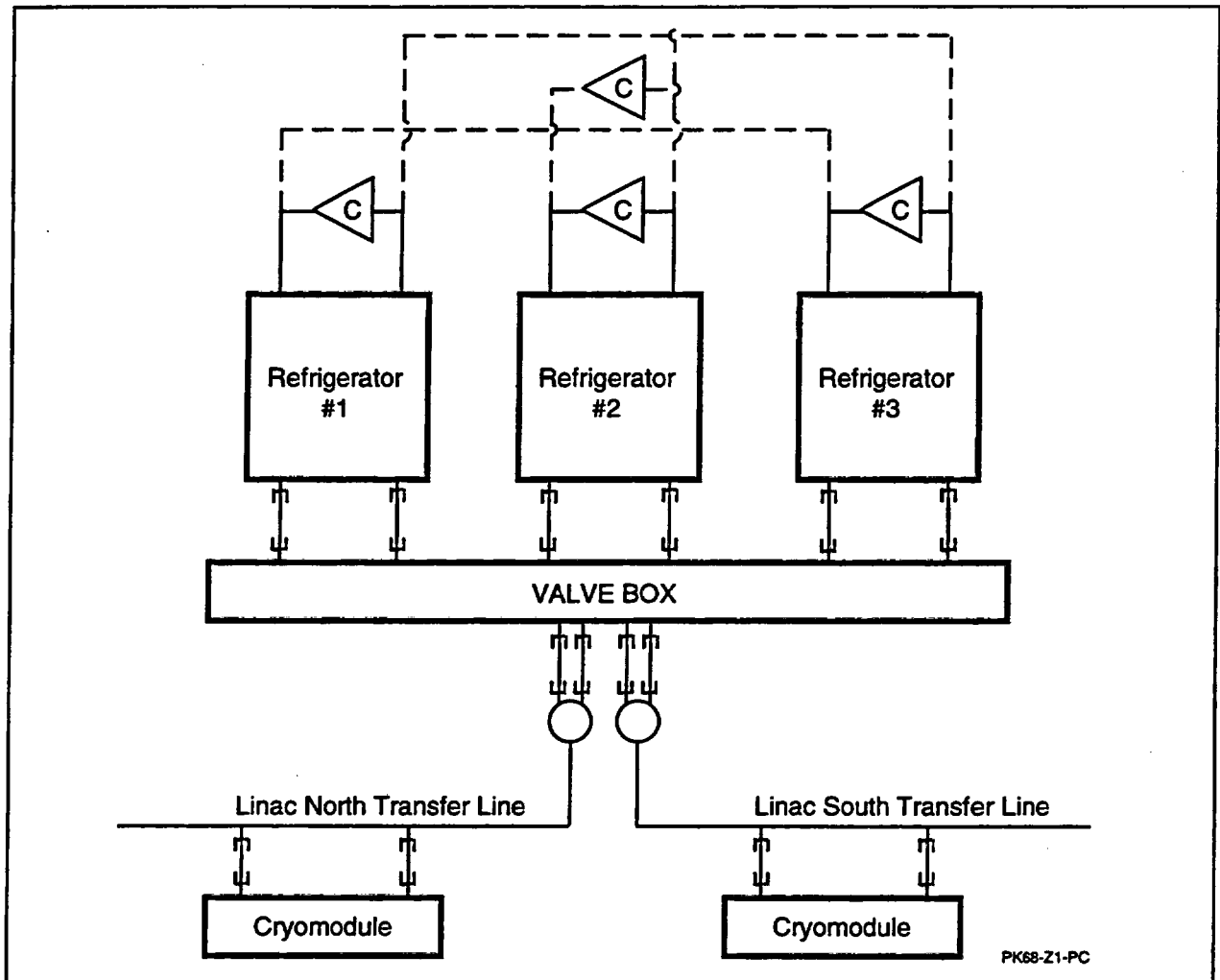

Figure A-23. APT Cryogenics System (LANL 1997).

suction or interstage suction. A second and third connection to each tank would be used for the purifier-loop connections, used to prevent particulate impurities from being carried over into the process stream.

The Liquid Helium Distribution System would include special vacuum-jacketed, thermally shielded cryogenic piping that would connect the three APT cryoplants with the superconducting components in the accelerator tunnel. Separate supply and return lines, would service the superconducting cavities and the superconducting quadrupoles. The distribution lines in the tunnel would have disconnecting connections to each cryomodule, with cryogenic valves

arranged to enable operation with a reduced number of cryoplants.

Each cryoplant would have two 76,000-liter liquid nitrogen dewars. The working pressure in the storage vessel would be 405,300 Pascal. These commercially available vessels would be produced in a horizontal configuration with an overall diameter of 3.3 meters, a height of 3.6 meters, and a length of 15.7 meters. The storage tank would be connected to the cryoplant through vacuum-jacketed transfer lines to minimize cryogen loss. The steady-state liquid nitrogen consumption rate for each plant would be 1,500 liters per hour, so each pair of tanks would have enough capacity to enable about four days of operation without refilling. Be-



cause a typical liquid nitrogen delivery truck can supply about 23,000 liters, the APT operation would require a continual delivery of approximately five trucks per day to keep up with the liquid nitrogen demand, or the construction of an onsite nitrogen recondenser facility.

#### **A.5.15 TARGET/BLANKET STAGING BUILDING**

This would be a steel frame structure adjacent to the Target/Blanket Building. The building would have space for unloading incoming complete target/blanket modules from a rail spur and inspecting them upon receipt. The building would contain pumps and test equipment to perform final hydrostatic tests on each unit. Racks for the modules would be provided to store the modules in the upright position while awaiting transfer to the target/blanket building. A gantry crane mounted on tracks on the floor of the building would be used to off-load the modules and load them on the transfer cart.

A one of a kind transfer cart would be provided on a track to move the modules from the staging building to the Target/Blanket Building. An air lock would be provided between the staging building and the Target/Blanket Building by double roll-up doors, with shielding provided by blocks stacked in front of the air lock.

#### **A.5.16 RADIOACTIVE WASTE TREATMENT SYSTEM**

The radioactive wastes generated by the APT facility would be classified as low-level and mixed waste; there would be no generation of high-level or transuranic wastes. The APT Radioactive Waste Treatment System would interface with and use all compatible waste facilities at the SRS, and would include systems to handle solid, liquid, and gaseous radioactive waste streams.

The major sources of APT radioactive waste would be spent resin from water treatment ion exchangers, personal protective equipment, job control material from routine operation and

maintenance activities, and the change-out of tungsten neutron source/decoupler modules, blanket modules, reflector modules, shield modules, and window modules. The primary treatment for personal protective equipment and job control wastes would be incineration in the SRS Consolidated Incineration Facility (CIF). The tungsten neutron source/decoupler modules and blanket modules would contain significant amounts of lead (a Resource Conservation and Recovery Act [RCRA]-regulated material), and would be contaminated with a number of radioactive isotopes. The target/blanket wastes would be placed initially in the target pools for tritium recovery and cooldown, and then would be treated to meet applicable RCRA requirements and waste acceptance criteria before disposal. Solid radioactive wastes with volumes small enough to preclude size reduction would require only packaging, characterization, and certification for disposal.

The Liquid Radioactive Waste System would consist of a heavy-water system, a light-water system, and a process-water system. The heavy- and light-water systems each would include a resin drying system, a liquid retention system, and a reverse-osmosis system. The process water system would include tunnel waste collection systems, Target/Blanket Building waste collection systems, oil removal systems, and reverse-osmosis systems.

The Gaseous Radioactive Waste System would receive and process waste gases from the Target/Blanket Systems -- the Cavity Vessel and Atmosphere System, the Gas Transport System -- and vented gases from various balance-of-plant systems. The system would receive gaseous effluents containing traces of spallation products and low levels of tritium, which would come primarily from the Target/Blanket Assembly System, the Target/Blanket Gas Transport System, and miscellaneous venting from target/blanket and accelerator segment processes. The effluent gases would be processed through a once-through pre-HEPA filter, a caustic scrubber, a dryer, and a HEPA filter, and then transported to decay holding tanks be-

fore being exhausted to the balance-of-plant HVAC stack.

#### **A.5.16.1 Solid Radioactive Waste System**

Most low-level waste and some mixed wastes generated at the APT would be personal protective equipment and routine job control and maintenance wastes. These wastes would be segregated and packaged in the appropriate standard site containers in accordance with waste acceptance criteria (WAC) for solid waste management. The containers would include 55-gallon drums, B-25 boxes, and B-12 boxes.

Some failed or spent APT components could require special casks to meet transportation and disposal requirements because of higher levels of radioactivity. These would include such items as T/B cavity vessel windows and tungsten neutron sources. Casks chosen for these wastes would be of suitable design to meet SRS solid waste management WAC for radiation shielding, transportation, handling, and storage.

The casks for the lead components from the target/blanket modules would have additional requirements. They would contain RCRA mixed wastes and would require an offsite disposal facility. The lids on the mixed waste casks would be welded closed with automatic equipment to minimize exposure to site personnel. The weld would be verified to ensure integrity and the cask would be inspected to ensure that it met the requirements for macroencapsulation of a RCRA mixed waste. Based on the final design of the target/blanket modules, additional remote handling equipment could be required for separation of the lead components from the modules, reduction of component size, and placement of materials into casks.

Resins from the liquid radwaste system would be dewatered and sealed in high-integrity containers for transfer to solid waste management. Packaging requirements for nonroutine low-level radioactive waste that was too large or irregular in shape to fit in standard site containers would be dealt with as needed with Solid Waste Engineering and Operations.

At the point of generation, APT personnel would segregate and package wastes. Health physics personnel would survey the packages prior to their transfer. Routine waste packages would go to the APT Solid Radwaste Building for staging and interim storage. Waste casks or large failed equipment meeting WAC would go directly to SRS solid waste management or to offsite disposal/treatment facilities. Each waste package would be prepared to comply with applicable requirements for documentation, certification, and labeling in preparation for transfer to the appropriate disposal facility. Documentation would be maintained in accordance with SRS requirements.

#### **A.5.16.2 Liquid Radioactive Waste System**

The liquid radwaste system would consist of three major systems: heavy water (D<sub>2</sub>O), light water (H<sub>2</sub>O, deionized water), and process-water radwaste systems.

##### **A.5.16.2.1 Heavy-Water Radioactive Waste System**

The heavy-water radwaste treatment system would consist of a resin dewatering system, liquid waste retention system, and a reverse-osmosis system. It would receive spent resin and backwash slurry from the tungsten target heavy-water polishing loop and would perform a liquid purification process by separation of solid, liquid, and gas wastes for storage, reuse, and disposal.

The heavy-water resin dewatering system would consist of a tungsten target high-integrity container (HIC), which would receive polishing-loop ion exchanger resin and filter backwash slurry at a maximum rate of 100 gpm. The HIC would be a DOT-certified container with internal resin filters. The HIC dewatering operation would remove the heavy water from the resin to less than 1 percent of the resin volume in residual water. The HIC would remove the excess water through resin filters, and the filtrate would be routed to liquid waste holding tanks in the liquid radwaste retention system. The dewatered resin would remain in the HIC. After

resin dewatering, the HIC would be characterized and transported by an overhead crane to a HIC concrete cask for solid waste disposal.

The heavy-water radwaste retention system would consist of one 25,000-gallon liquid waste holding tank with two transfer pumps, an agitator, a level switch, and control instrumentation. The holding tank would receive filtered heavy water from the resin dewatering HIC and leakage of heavy water collected in the holding tank vault. The liquid waste holding tank would be in a stainless-steel-lined shield vault. The vault would have a sump, a sump pump, a liquid level detector, and control instrumentation. Two 100-percent capacity pumps in the tanks would transfer radwaste liquid to a reverse-osmosis system for purification.

The heavy-water reverse-osmosis system would consist of one microfilter, a two-stage reverse osmosis unit, three holding tanks, one filter backwash tank, one condensate tank, one evaporator with heating coils, feed pumps, instrumentation, and a programmable logical control system. The reverse-osmosis system would purify the liquid radwaste stored in the heavy-water radwaste holding tank.

At the end of filtration, the microfilter would be backwashed by the first-stage reverse-osmosis feed pump using the filtrate. The filter backwashed slurry would be discharged to a backwash tank. The first-stage reverse-osmosis unit would be backwashed by the second-stage reverse-osmosis feed pump using the first-stage permeate. The backwashed slurry would be routed to the concentrate tank. The second-stage reverse-osmosis unit would be backwashed by a condensate feed pump using condensate water. The backwashed water would be routed to the first-stage reverse osmosis holding tank. Finally, the microfilter would be backwashed by the first-stage reverse-osmosis feed pump.

The evaporator would receive the backwash and the concentrate tank slurry and would perform the dewatering process. Excess water would be returned to the heavy-water radwaste holding

tank for reprocessing. After excess water was removed from the evaporator, the slurry would be heated by the heating coils. Vapor and gases would be removed from top of the vessel and routed to the gaseous radwaste system. Solids would be collected from the bottom of the vessel for transfer to drums as solid waste.

#### **A.5.16.2.2 Light-Water Liquid Radioactive Waste System**

The light-water liquid radwaste treatment system would consist of a resin drying system, a liquid waste retention system, and a reverse-osmosis unit. The system would receive spent resins and backwash slurry from blankets, windows, shields, the target storage pool, and the closed-loop polishing systems, including leakage from the closed-loop cooling systems, and would perform a liquid purification process.

The light-water resin drying system would consist of a spent resin holding tank and a packaged high-integrity container (HIC). The spent resin holding tank would be an intermediate receiver to combine spent resin from the light-water closed-loop polishing system and to filter backwash slurry discharge to one HIC. The 3,000-gallon tank would temporarily store partial volumes of liquid waste generated in one ion exchanger in the closed-loop polishing systems, if the HIC was at a high level.

The light-water radwaste retention system would consist of one liquid waste holding tank with two transfer pumps, an agitator, a level switch, and control instrumentation. The holding tank would receive filtered light water from the resin dewatering HIC and leakage from the closed-loop light-water systems collected in the holding tank vault. The light-water radwaste retention system would be similar in design and operation to the heavy-water radwaste retention system.

The light-water reverse-osmosis system would consist of two packaged reverse-osmosis systems. One system would be in operation and the other would be in standby mode. The reverse-osmosis system would process liquid

waste from the light-water radwaste holding tank. The light-water reverse-osmosis system would be similar in design and operation to the heavy-water reverse-osmosis system, except excess water from the evaporator would be returned to the light-water radwaste holding tank for reprocessing.

#### **A.5.16.2.3 Process-Water Radioactive Waste System**

The process-water radwaste system would consist of a tunnel waste collection system, a target/blanket building waste collection system, an oil-separation system, and a reverse-osmosis system.

The tunnel waste collection system would consist of 20 sumps with pumps to collect leakage from heat removal systems and fire protection systems in the accelerator tunnel. The sumps would be located every 61 to 67 meters along the tunnel. The system design capacity would be based on a 350-gallon-per-minute fire sprinkler discharge in a designated 2,500 square feet of fire-protected area in accordance with National Fire Protection Association (NFPA) Ordinary Hazard, Class 1 Classification, with water density at 0.13 gallons per minute per square foot. The 350 gallons per minute of fire water would be collected in two sumps and transferred through a 6-inch pipe header to a process-water radwaste holding tank. Each sump would be lined with stainless steel. The sump and sump pump would be able to handle 50 percent of the capacity of fire water. A level switch and alarm at each sump would automatically control the pump operation.

The Target/Blanket Building waste collection system would consist of a stainless-steel sump, a sump pump, and a 25,000-gallon process-water waste holding tank with an agitator, two transfer pumps, level switches, alarms, and control instrumentation. This system would be on the bottom floor level and would collect floor drain waste, leakage from closed cooling loop systems, and fire sprinkler discharged water. The sump would be stainless steel lined to prevent leakage, and would have level switches, alarms,

and instrumentation for automatic pump control operation. Sump water would be pumped to the process-water radwaste holding tank.

The process-water radwaste holding tank would be in a shielded vault. Two 100-percent capacity pumps in the tanks would transfer radwaste liquid to an oil separation system, and then to a reverse-osmosis system for processing. Overflow liquid from the holding tank would be drained temporarily to the sump. When the tank liquid level was reduced, the overflow liquid in the sumps would be pumped back to the tank.

The oil separation system in the process-water radwaste system would separate oil and water before reverse-osmosis treatment. Wastewater received in the process-water holding tank could contain machine oil or grease from area building sumps. Liquid waste would be treated through a packaged oil separation system, which would include prefilters, coalescing filters, air filters, and an oil holding tank.

The reverse-osmosis unit would consist of spiral-wound reverse-osmosis membranes that would provide as much as 0.3 micron particulate retention. The rejection rates and recovery rate of the two-stage reverse-osmosis unit would be 15 to 30 percent and 70 to 85 percent, respectively. The filtration process of the reverse-osmosis system would be sized to process 20,000 gallons of liquid waste in approximately 12 hours of continuous operation.

#### **A.5.16.3 Gaseous Radioactive Waste System**

The gaseous radwaste system would include the gaseous waste handling system from the interfaces with the effluent gases from the target/blanket gas systems, the gas transport system, the radwaste systems, and other APT blanket gas uses to the interface with the balance-of-plant HVAC target/blanket stack. It would also include a water supply from the interface with the domestic water system to the interface with the liquid radwaste system where the water from the moisture separator discharged.

The gaseous radwaste system would consist of a vacuum pump to transfer the gaseous radwaste from various gaseous waste systems to one of two waste gas storage tanks, in which the potentially radioactive gas would be monitored to determine if it contained acid or radioactive material. Gaseous waste that contained permissible acid or radiation levels for discharge would be vented directly to the balance-of-plant HVAC target/blanket stack. Gaseous waste containing acid or radioactive material would be transferred through a blower and through a gas scrubber in which nitric acid would be removed; then it would pass through a moisture separator to remove entrained moisture, and then it would be heated to a temperature above the dew point. Gases containing no radioactivity would then be vented to the balance-of-plant HVAC target/blanket stack. Radioactive gases would be passed through a HEPA filter to remove radioactive particles. The gaseous waste would be compressed to 20 atmospheres, passed through a moisture separator, and stored in holding tanks until remaining radioactive isotopes decayed to acceptable levels for venting through the stack. It would be vented through the stack, and the tanks would be ready to receive more gaseous waste.

Accumulated water from the moisture separators and wastewater from the gas scrubber would be discharged to the liquid radwaste system.

#### **A.5.16.4 Radioactive Waste Building**

The Radioactive Waste Building would provide storage for packaged solid radioactive waste before shipment for final disposition. The building would be a steel frame building with metal siding on reinforced concrete footings with a slab on grade floor.

The Radioactive Waste Building would have space for the following functions:

- Storage and staging for shipping low-level radioactive solid waste packaged in site approved waste containers.

- Storage and staging for shipping solid mixed waste containers.
- Storage and staging for shipping hazardous radioactive solid waste.
- Storage and staging of packaged dirty clothing before transport for cleaning.
- Storage of burnable packaged solid waste before transport to the SRS Consolidated Incineration Facility.

There would be space for an administrative office where records would be retained. A loading dock would be provided for the handling of material. Material would be handled by forklift-type equipment, with no cranes.

## **A.6 Other Support Facilities and Systems at the Savannah River Site**

The Savannah River Site has a range of support services and facilities, including onsite transportation capabilities (truck and rail), hazardous and sanitary waste processing facilities, central engineering and maintenance functions, and other specialized support. The following sections discuss facility groups directly associated with the APT project: the Tritium Loading Facility (TLF), the Tritium Extraction Facility (TEF), M-Area facilities, and waste facilities.

### **A.6.1 TRITIUM LOADING FACILITY**

The existing SRS Tritium Facilities consist of the Tritium Loading Facility (Building 233-H) and associated support facilities in H-Area, as shown in Figure A-24. The TLF (formerly known as the Replacement Tritium Facility) was designed for gas handling operations (filling and emptying reservoirs), product separation, and enrichment activities. Tritium is received in reservoirs returned from the field or as "fresh" tritium from a production facility. Reservoirs or shipping containers are unloaded and the gases are processed to separate hydrogen isotopes from

**Table A-2. M-Area Facility functional support compatibility.<sup>a</sup>**

Function	Floor space required (m <sup>2</sup> )	Possible locations
Construction Staging	9,290	All M-Area Buildings <sup>b</sup>
Equipment Receipt/Inspection	929 - 9,290	320-M, 321-M <sup>c</sup> , 315-M (if heated)
Motor Control Center, Circuit Breaker, Instrument Rack, Beam Diagnostics Storage	3,252	320-M, 321-M (partial), 313-M (partial); with HVAC additions: 315-M, 330-M, 331-M
Circuit Breaker, Instrument Rack, Beam Diagnostics Device Testing	975	320-M, 321-M, 313-M (if co-located), or 322-M
He-3/Tritium Gas Loop Fabrication/Test	929	321-M
Control Room Simulator	822	321-M
Program Development Center	790	320-M, 321-M
Magnet Equipment Maintenance	465	320-M, 321-M
Target/Blanket Component Fabrication	372	320-M, 321-M
Vacuum Valve Testing	93	313-M, 320-M, 321-M
Training Facility	93	313-M, 320-M, 321-M; 305-1M with HVAC and fire protection
Target/Blanket Component Flow Testing	46.5	320-M <sup>d</sup>
Tritium Implantation Studies	18.6	313-M, 320-M, 321-M, 322-M

a. Source: WSRC (1996).

b. Depends upon construction contract. This function cannot be located in any single M-Area building due to space limitations.

c. This function may not be located in any single M-Area building due to space limitations.

d. Target/blanket component flow testing may be co-located with the accelerator target flow testing, which will not be in M-Area.

ment, and packaging capabilities prior to shipment for treatment and disposal of APT-generated non-radioactive wastes (except domestic wastewater, which would flow directly from the APT sanitary sewer system to the SRS sanitary sewer system). In addition to any other non-radioactive liquid waste, this system would handle domestic, industrial, and hazardous solid wastes and would interface with existing and planned SRS waste facilities.

Small quantities of process wastewater could be incinerated at the Consolidated Incineration Facility or stabilized for disposal as solid waste in the E-Area Vaults. Most APT process wastewater would go to a liquid effluent treatment facility and outfall, or directly to an outfall.

Contaminated APT process wastewater would go to a new facility built to support the APT.

All radioactive waste generated by the APT would be low-level waste; no high-level or transuranic wastes would be generated. DOE treats and stores wastes generated from SRS operations in waste management facilities in E-, F-, H-, N-, S-, and Z-Areas (Figure A-25). Major facilities include the high-level waste tank farms, the Low-Level Radioactive Waste Disposal Facility, the F- and H-Area Effluent Treatment Facility, the Defense Waste Processing Facility, and the Consolidated Incineration Facility.

DOE stores liquid and solid wastes on the SRS. Liquid high-level radioactive waste is stored in

underground storage tanks, which are managed in accordance with Federal laws, South Carolina Department of Health and Environmental Control (SCDHEC) regulations, and DOE Orders.

#### **A.6.4.1 Low-Level Solid Waste**

At the SRS, low-level waste is categorized for onsite disposal in the Low-Level Radioactive Waste Disposal Facility according to the waste category and surface radiation dose. The primary categories include low-level, intermediate-level, and long-lived wastes. The SRS also distinguishes between wastes that have low surface radiation doses and can be handled directly, and those that require remote handling.

Low-activity waste is loaded in steel boxes and can be shipped either to the Low-Level Radioactive Waste Disposal Facility in E-Area (Figure A-26) or to the H-Area compactor. If the waste is compacted, waste is added to the steel boxes and compacted until the boxes are full. The boxes are taken to waste disposal vaults in E-Area for final disposal.

#### **A.6.4.2 Low-Level Liquid Waste**

The F- and H-Area Effluent Treatment Facility (ETF) decontaminates and treats low-level process water and stormwater contaminated with radioactive and chemical constituents. Routine influents accepted by the ETF are primarily evaporator condensates from the chemical separations facilities and the tank farms. Approximately 34 percent of the influent to the F- and H-Area ETF comes from F-Area, including the separations facility, cooling and stormwater retention basins, evaporator overheads, and laboratory liquid waste. H-Area influents comprise approximately 48 percent of the influents and include the separations facility, cooling and stormwater retention basins, evaporator condensate, tritium laboratory liquid waste, water inside the In-Tank Precipitation dike (an embankment designed to control water runoff),

and laboratory liquid waste. The remainder comes from other F- and H-Area facilities.

The F and H-Area Effluent Treatment Facility was built to replace the old F- and H-Area seepage basins, which, under the 1984 Hazardous and Solid Waste Amendments to the Resource Conservation and Recovery Act, could not be used after 1988. The F- and H-Area ETF began operation in October 1988.

The F- and H-Area Effluent Treatment Facility decontaminates wastewater through a series of steps which consist of pH adjustment, submicron filtration, heavy-metal and organic adsorption, reverse osmosis, and ion exchange. The treatment steps concentrate contaminants in a smaller volume of secondary waste, which is concentrated further by evaporation. The waste concentrate is eventually disposed of in the Z-Area Saltstone Manufacturing and Disposal Facility. The treated effluent is analyzed to ensure that it has been properly decontaminated, and then discharged to Upper Three Runs Creek.

#### **A.6.4.3 Long-Lived and Intermediate-Level Waste**

DOE will store long-lived wastes, such as resins, in temporary facilities until the long-lived waste storage building in E-Area can begin operations. This building will provide storage until DOE develops treatment and disposal technologies.

To ensure improved containment the SRS developed the E-Area vaults, which began receiving low-level radioactive waste in November 1994. This facility ultimately will receive low-activity, intermediate-level nontritium, and tritium waste.

DOE packages intermediate-level wastes according to the waste form and disposes of them in slit trenches. Some intermediate-level waste, such as contaminated equipment components, is wrapped in canvas before disposal.

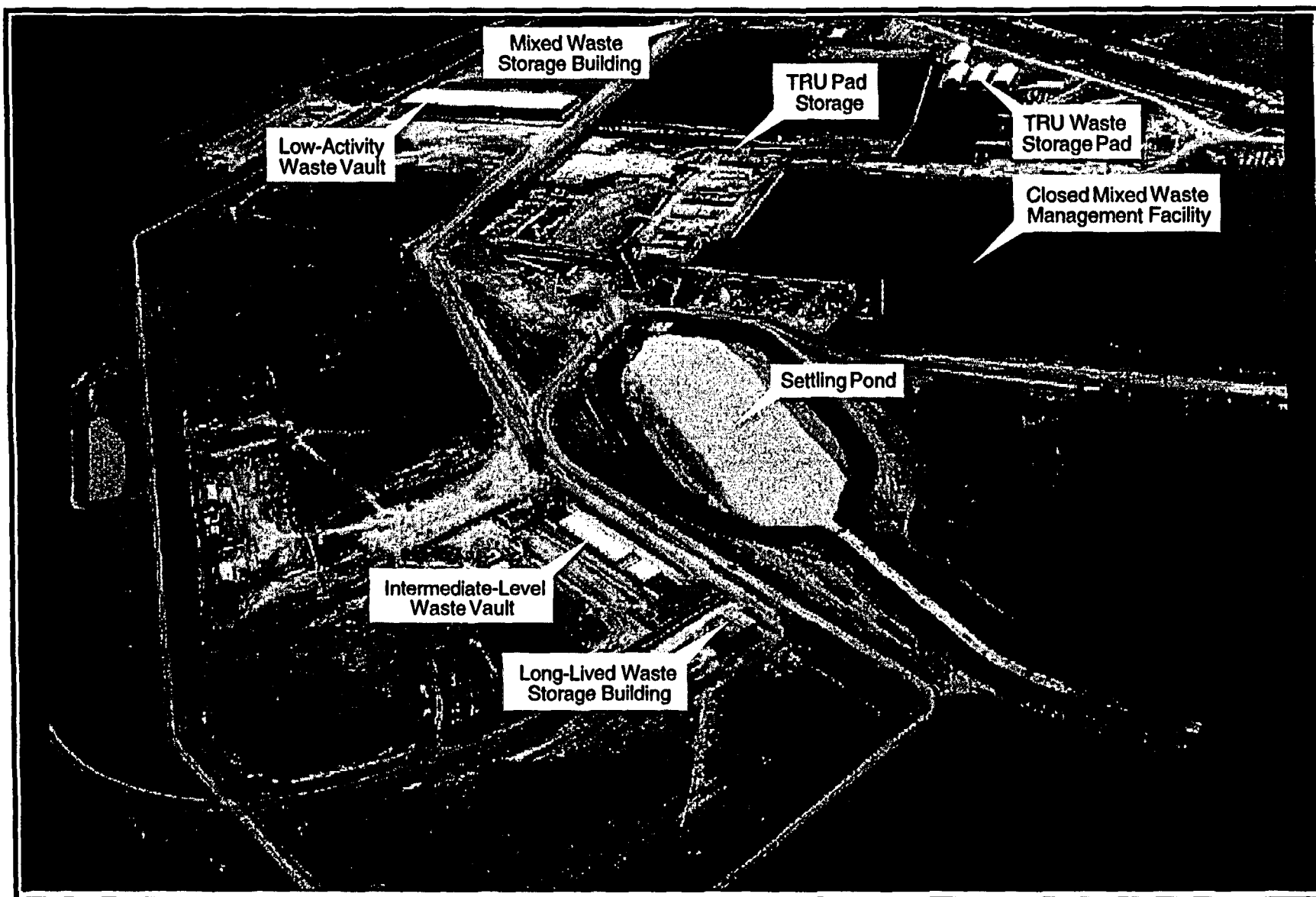

PK68-Z1-PC

Figure A-26. Low-Level Radioactive Waste Disposal Facility (E-Area).



**A.6.4.4 Hazardous and Mixed Waste**

Hazardous waste is defined as discarded materials (both liquid and solid) that are either characteristically hazardous or are listed as hazardous under the Resource Conservation and Recovery Act. Characteristically hazardous materials are corrosive, ignitable, reactive, or toxic. Hazardous waste includes organic liquid, debris, or sludges; aqueous liquid, debris, or sludges; metal debris; glass debris; inorganic sludges; and soils that do not contain radionuclides. If they are contaminated with radionuclides, they are separated as mixed waste.

Mixed waste is hazardous waste that contains radioactivity; it is further classified according to

its radioactive component. The primary consideration of the management of low-level mixed waste is its hazardous components, while the primary consideration of the management of high-level and transuranic mixed wastes is the radioactive component. SRS mixed wastes are stored in permitted or interim-status facilities such as the hazardous waste storage facilities (building and pads) and in the mixed waste storage buildings. Figure A-27 shows waste handling processes for other forms of waste at SRS.

At the SRS, hazardous waste is stored temporarily at hazardous waste storage facilities in buildings in B- and N-Areas and on adjacent

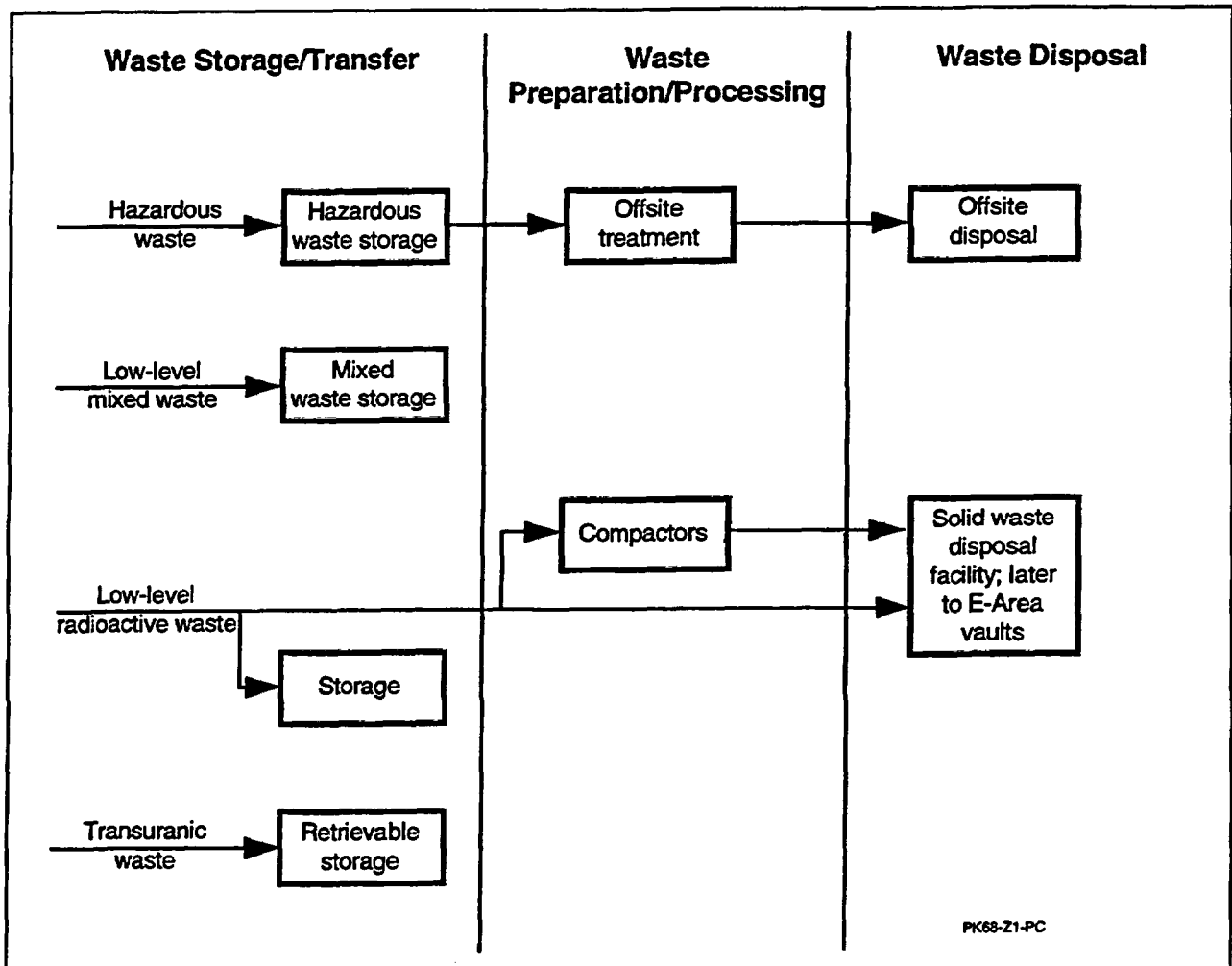

Figure A-27. SRS waste handling processes.

storage pads before shipment to offsite permitted treatment, storage, and disposal facilities. DOE began offsite shipments of hazardous wastes to treatment and disposal facilities in 1987. In 1990 DOE imposed a moratorium on shipments of hazardous waste from radiologically controlled areas or that had not been proven to be nonradioactive. The SRS continues to ship hazardous waste that is validated as nonradioactive (e.g., solvents) offsite for recycling, treatment, or disposal.

#### A.6.5 RIVER WATER SYSTEM

Chapter 2 summarizes the options available to transfer heat from APT activities to the environment. Three of the four alternatives use water from the Savannah River for this cooling function. This section describes the River Water System and modifications needed to support the APT.

Figure 2-5 shows the River Water System which DOE originally installed to provide cooling water for the five SRS production reactors. The reactors (C, K, L, P, and R) produced and processed nuclear materials for defense, research, and medical programs of the United States. The River Water System provided cooling water that passed through heat exchangers to absorb heat from the reactor core. Par Pond and L-Lake are manmade reservoirs constructed in 1958 and 1984, respectively, to provide additional cooling water for P, R, and L reactors. All five reactors have been shut down: R in 1964; C in 1985; P and L in 1988; and K in 1993. A separate analysis (DOE 1997) documents options associated with the shutdown of the River Water System now that the reactors have ceased operation.

The River Water System includes three pump-houses, two on the Savannah River

(Pumphouses 1G and 3G) and one on Par Pond (Pumphouse 6G). Pumphouses 1G and 6G no longer operate. Each pumphouse contains 10 pumps; pump capacities vary from 24,000 gallons per minute to 32,500 gallons per minute. Approximately 50 miles of underground concrete piping can deliver river water from the pumphouses to the reactor areas. When the reactors were operating, the River Water System delivered 174,000 gallons per minute to each reactor area. At present, DOE operates one of the 10 pumps in Pumphouse 3G to satisfy small equipment cooling loads in K-, L-, and P-Areas. Pumphouse 5G is also on the Savannah River, but it is a separate piping system that supplies cooling water to the D-Areas powerhouse.

#### A.6.6 K-AREA COOLING TOWER

Under one of the alternatives, DOE could use the K-Area Cooling Tower to provide cooling water for the APT facilities. This tower was built to provide cooling for K-Reactor but was never used because the reactor was shut down before the tower was completed. The construction and operation of the cooling tower was analyzed in the *Alternative Cooling Water Systems Final Environmental Impact Statement* (DOE 1987), and DOE issued the Record of Decision in early 1988.

The cooling tower is 140 meters high and 105 meters in diameter at the base. The system consists of a single recirculating, gravity-flow, natural-draft cooling tower that would use water from the Savannah River as makeup water for leaks and evaporative losses. As designed, discharges from the cooling tower are combined with water from the Savannah River (to ensure that temperatures remain below 90° F at all times) and released to Indian Grave Branch, which flows into Pen Branch and eventually into the Savannah River.

## References

- Badger, George M., "The Klystrode™, A New High-Efficiency UHF TV Power Amplifier," Varian EIMAC, San Carlos, California.
- DOE (U.S. Department of Energy), 1987, *Alternative Cooling Water Systems Final Environmental Impact Statement, Savannah River Plant, Aiken, South Carolina*, DOE/EIS-0121, Savannah River Operations Office, Aiken, South Carolina.
- DOE (U.S. Department of Energy), 1995b, *Final Programmatic Environmental Impact Statement for Tritium Supply and Recycling*, DOE/EIS-0161, Office of Reconfiguration, Washington, D.C., October.
- DOE (U.S. Department of Energy), 1997, *Shutdown of the River Water System at the Savannah River Site Final Environmental Impact Statement*, DOE/EIS-0268, Savannah River Operations Office, Aiken, South Carolina, May.
- LANL (Los Alamos National Laboratory), 1997, *Conceptual Design Report*, LA-UR-97-1329, Los Alamos, New Mexico, April 15.
- Peters, R. D., A. Haase, C. Johnson, and R. N. Tomoe, 1994, "The Klystrode® IOT, A New, Compact, High Efficiency Electron Tube," *Proceedings of the Materials Research Society Symposium*, Volume 347, pp. 97-108.
- WSRC (Westinghouse Savannah River Company), 1996, "Report on Use of Excess M-Area facilities," SPM-TMD-96-0132, Savannah River Site, Aiken, South Carolina.

# Appendix B

Accidents

---

**APPENDIX B**

**ACCIDENTS**

## TABLE OF CONTENTS

<u>Section</u>	<u>Page</u>
B.1 Analysis Methodology.....	B-1
B.2 Accident Scenarios .....	B-2
B.2.1 Loss of Primary Flow Accident in Target Heat Removal Primary System .....	B-2
B.2.2 Loss of Secondary Side Heat Sink in Target Heat Removal Primary System.....	B-2
B.2.3 Chemical Releases .....	B-2
B.2.4 Loss of Confinement (Tunnel Purge of Normally Activated Air Without Delay) .....	B-3
B.2.5 Resin Bed Fire.....	B-4
B.2.6 Target Cooling Pipe Break.....	B-4
B.2.7 Full Power Beam/Beam Stop Interaction.....	B-5
B.2.8 Misdirection/Misfocusing of High-Energy Beam (With Loss of Confinement).....	B-6
B.2.9 Target-Handling Accident.....	B-7
B.2.10 Failure Of Beam Expander.....	B-8
B.2.11 Design-Basis Seismic Event.....	B-8
B.2.12 Beyond-Design-Basis Seismic Event.....	B-9
B.2.13 Failure to Trip Accelerator Beam During a Thermal Hydraulic Transient in the Target (Beyond Design Basis).....	B-11
B.2.14 Large Fire in Tritium Separation Facility.....	B-12
B.2.15 Small Fire in Tritium Separation Facility .....	B-13
References .....	B-14

### List of Tables

<u>Table</u>	<u>Page</u>
B-1 Chemical release source term and evaluation.....	B-3
B-2 Loss of confinement (tunnel purge of normally activated air without delay) source term.....	B-3
B-3 Target resin bed source term .....	B-4
B-4 Large loss of coolant accident in the target heat removal primary system (outside the target/blanket cavity) source term.....	B-5
B-5 Full-power beam/beam stop interaction scenario source term.....	B-6
B-6 Misdirection/misfocusing of high-energy beam scenario source term (metal ions only).....	B-7
B-7 Source term for beyond design basis seismic scenario (blanket). .....	B-10
B-8 Source term for beyond design basis seismic scenario (blanket coolant).....	B-11

## APPENDIX B. ACCIDENTS

### B.1 Analysis Methodology

To develop the accident scenarios described in this appendix, the U.S. Department of Energy (DOE) used the hazard-based approach described in Departmental Standard 3009-94, *Preparation Guide for US DOE Non-Reactor Nuclear Facility Safety Analysis Reports* (DOE 1994). This is a systematic approach to develop safety documentation that is consistent with the level of hazard. DOE developed accident scenarios for the accelerator, target/blanket, Tritium Separation Facility, and the Associated Support Facilities. Based on this analysis, DOE has determined that not all scenarios would have an impact on the environment or the public. This appendix describes each analyzed accident scenario and its likelihood, source term, and consequences.

In general, the analysis used the computer codes LAHET, MCNP, and CINDER90 (LANL 1989, 1993) to calculate the radionuclide inventory available for potential release in these postulated accident scenarios. DOE developed release fractions specifically for each scenario that resulted in a source term, entered the source term in the MACCS2 (Chanin and Young 1997) code, and estimated the consequences using 95th-percentile meteorology for the Savannah River Site (SRS). Chemical releases were modeled with ALOHA (EPA and NOAA 1992).

Virtually all of the radionuclides created by the accelerator would be in the focus of the beam in the target/blanket structure. As a consequence, most of the postulated accident scenarios focus on the target/blanket structure and its support equipment.

The tungsten neutron source is clad in Inconel, which has a high resistance to oxidation. DOE used a conservative failure temperature of 1,250°C in the calculation for this analysis. In scenarios that would involve heating the tar-

get/blanket structure, the tubes would remain intact and no release would occur as long as structural temperatures were below 1,250°C. However, if the target/blanket temperature exceeded 1,250 °C, DOE assumed that the material in the tubes would vaporize and become available for release. The blanket is lead clad in aluminum. The tritium producing elements for both the He-3 and Li-6 feedstock material alternatives are also surrounded by aluminum which melts at 660°C.

All the scenarios with the exception of the Beyond-Design-Basis Event described in Section B.2.13 assumed the quick termination of the accelerator beam because the design includes redundant sensors and shutdown systems to detect beam problems and terminate its operation before significant damage could occur. Sensor indications used to terminate the beam would include increased radiation levels in the beam tunnel, high temperature or pressure in the target/blanket cooling system, changing water levels in the cooling system, and beam diagnostic readings. Multiple failures of the Beam Shutdown System would not be credible. However, DOE included this accident scenario for completeness. All releases of tritium described in this appendix are conservatively assumed to be tritium oxide. Unless otherwise specified, all references in this appendix are to Liscom-Powell 1997.

Accidents for the staged design option and the proposed inclusion of the Tritium Extraction Facility (TEF) within the APT are not specifically included in this Appendix. This is because the consequences of the analyzed accidents would bound the corresponding accident for other design options. In the case of the staged design option, the beam energy and current and associated accident consequences would be less than already analyzed cases. The TEF located at the APT site would be bound by the tritium inventory limits already analyzed in this document.

## B.2 Accident Scenarios

### B.2.1 LOSS OF PRIMARY FLOW ACCIDENT IN TARGET HEAT REMOVAL PRIMARY SYSTEM

For this scenario, DOE postulated a loss-of-flow accident (LOFA) in the Target Heat Removal Primary System (THRPS). This event could result from a single pump failure or the loss of both pumps. As part of this scenario, the accelerator beam would be terminated. Other systems would activate including the Residual Heat Removal (RHR) system, and the Cavity Flood System if needed. The RHR primary pumps would have a battery power supply and a backup diesel generator system that is single failure proof.

**Source Term.** Because of the number of independent ways to shut off the accelerator beam and to provide cooling to the target/blanket assembly (Primary Coolant and Residual Heat Removal Systems), the cladding temperature of the target/blanket would remain below the failure point and, therefore, the Target Heat Removal Primary System would not release any radionuclides.

**Likelihood.** The estimated frequency for a complete loss-of-flow accident in the Target Heat Removal Primary System could be 0.13 per year. (LANL 1997)

**Consequence Estimates.** Because this scenario would not release radionuclides, its consequences would be negligible.

### B.2.2 LOSS OF SECONDARY SIDE HEAT SINK IN TARGET HEAT REMOVAL PRIMARY SYSTEM

**Scenario.** DOE postulated the effects of a loss-of-heat-sink (LOHS) accident for the Target Heat Removal Primary System. A LOHS would involve a loss-of-flow accident or a loss-of-coolant accident (LOCA) in the Target Heat Removal Secondary System, resulting in a loss of heat rejection capability from the THRPS. This scenario bounds all postulated LOHS

events. As part of the scenario, the accelerator beam would quickly terminate and other systems would activate including the Residual Heat Removal System, and if needed, the Cavity Flood System.

**Source Term.** Because of the number of independent ways to shut off the accelerator beam and to provide cooling to the target/blanket assembly (Residual Heat Removal and Cavity Flood Systems), the target/blanket would remain cooled for the scenario and, therefore, the Target Heat Removal Primary System would not release any radionuclides.

**Likelihood.** The estimated frequency for a complete loss-of-heat-sink accident involving the Target Heat Removal Primary System could be 0.13 per year. (LANL 1997)

**Consequence Estimates.** Because this event would not release radionuclides, its consequences would be negligible.

### B.2.3 CHEMICAL RELEASES

**Scenario.** DOE has determined that chemical hazards associated with the operation of an accelerator would be standard industrial hazards, such as those associated with chemicals used in the water treatment of cooling systems in industrial plants. In addition, DOE would perform an acid etch cleaning of the radiofrequency tubes in the Radiofrequency Tube Remanufacturing Facility, and would use laboratory quantities of chemicals in the analytical laboratory.

A review of the typical chemical inventories DOE could use in the accelerator indicates three chemicals would exceed 40 CFR 302.4 Reportable Quantities -- ammonium hydroxide, hydrofluoric acid, and hydrazine. For each chemical, this scenario assumes the release of the entire inventory at a single location though not simultaneously. The analyzed chemicals would not be stored in the vicinity of radioactive materials. Therefore, involvement of radioactive materials in chemical accidents is not plausible.



**Source Term.** Table B-1 lists the types and quantities of chemicals released.

**Table B-1.** Chemical release source term and evaluation.

Chemical	Release quantity (kg <sup>a</sup> )	Concentration at 640 meters (ppm <sup>b</sup> )	OSHA PEL (ppm)	OSHA evaluation
Hydrofluoric acid	150	1.0	3	Less than PEL <sup>c</sup>
Hydrazine	25	0.05	0.1	Less than PEL
Ammonium hydroxide	3,500	6.0	35	Less than PEL

- a. kg = kilograms.
- b. ppm = parts per million.
- c. PEL = Permissible Exposure Levels.

**Likelihood.** A large chemical release could occur with a frequency of 0.1 per year.

**Consequence Estimate.** Analysis of releases of these quantities of chemicals shows that the concentration at the location of the uninvolved worker (640 meters) is significantly less than their respective Occupational Safety and Health Administration (OSHA) Permissible Exposure Levels (PELs). Concentrations of these chemicals at even greater downwind distances (i.e., to the MEI) would be even lower. Because the estimated chemical concentrations would be much less than their respective limits, the consequences of this scenario would be negligible.

#### B.2.4 LOSS OF CONFINEMENT (TUNNEL PURGE OF NORMALLY ACTIVATED AIR WITHOUT DELAY)

**Scenario.** This scenario would involve a worst-case release (purge without delay) of the activated air products produced in the beam tunnel from normal beam operation. The scenario assumes that the maximum quantity of radionuclides – which would be produced by beam interactions with tunnel air -- would be present in the tunnel at the time of their inadvertent purge to the environment.

**Source Term.** DOE used the LAHET/MCNP/CINDER90 set of codes to estimate

the accelerator tunnel inventory. The analysis assumed a 9-month, 10 nanoamperes/meter (nA/m), 1,700 MeV proton beam spill over the length of the accelerator, and that no tunnel air would exhaust until immediately after the 9-month period. The maximum allowable beam spill would be 10 nA/m during normal operations; this, plus the fact that the tunnel air is continuously exhausted, provides a bounding estimate of the inventory after 9 months. The source term consists of about 3 curies of activated air and decay products inside the accelerator tunnel. Table B-2 lists the dominant radionuclides that would contribute to the downwind radiological doses; nuclides that are not listed in the table constitute less than 2 percent of the released activity.

**Table B-2.** Loss of confinement (tunnel purge of normally activated air without delay) source term.

Nuclide	Activity (curies)
N-13	1.3
Ar-41	0.46
O-15	0.44
C-11	0.32
C-14	0.038
H-3	0.017
Be-7	0.013
Ar-37	0.012
Total	2.6

**Likelihood.** Although it is unlikely that (1) a prolonged, 10 nA/m beam spill would remain undetected and the beam promptly terminated and (2) the tunnel air would remain stagnant for 9 months, DOE assumes that the bounding source term release described above (approximately 3 curies) could occur with a frequency of 0.01 per year.

**Consequence Estimates.** The analysis used the source term listed in Table B-2 to estimate the radiological dose and risk to downwind receptors. DOE used the MACCS2 code, using SRS-specific meteorological information, to conduct the dispersion analysis and compute

downwind doses and projected latent cancer fatalities in the surrounding population.

The calculated doses were negligible.

### B.2.5 RESIN BED FIRE

**Scenario.** This scenario involves a fire in the resin bed of the Primary Coolant Loop Purification System. The fire would release the entire radioactive inventory in the resin bed to the atmosphere. Other Coolant Purification System resin beds, (e.g. window, blanket, accelerator) would contain less activity, as DOE would change the resin before the radioactivity reached quantities postulated for the primary tungsten cooling purification resin bed. A fire involving more than one resin bed is not a credible event.

**Source Term.** The resin beds will be periodically changed to limit the amount of radioactivity (e.g. to reduce the risk of a fire and to limit worker exposure). The resin loading for the ion exchanger beds is assumed to be administratively limited such that the unmitigated release of the resin bed inventory would result in consequences below the off site evaluation guidelines. The inventory of the target resin bed is shown in Table B-3.

Table B-3 Target resin bed source term.

Nuclide	Activity (Ci)
H-3	10,000,000
O-15	4,000,000
C-11	1,700,000
N-13	680,000
Be-7	2,900
Cr-51	1,700
F-18	1,400
Ar-37	83
I-125	76
Xe-127	75
Al-28	71

**Likelihood.** A resin bed fire that contained the maximum administrative limit of radionuclides could have an assumed frequency of 0.01 per year.

**Consequence Estimates.** The analysis used the source term listed in Table B-3 to estimate the radiological dose and risk to downwind receptors. DOE used the MACCS2 code, using SRS-specific meteorological information, to conduct the dispersion analysis and compute downwind doses and projected latent cancer fatalities in the surrounding population.

The calculated dose to the Maximally Exposed Individual from this scenario is 0.48 rem. The calculated dose to the uninvolved worker at a distance of 640 meters is 75 rem. The calculated dose to the population within 50 miles would be 800 person-rem, which is postulated to result in 0.40 excess cancer fatalities.

### B.2.6 TARGET COOLING PIPE BREAK

**Scenario.** This scenario postulates a large loss-of-coolant accident involving the Target Heat Removal Primary System. As part of this scenario, the accelerator beam would be quickly terminated. Other systems would activate or trip as designed, including primary coolant pumps (to prevent actively draining the breached primary system), the Residual Heat Removal System, and if needed, the Cavity Flood System.

If the coolant pipe break was inside the target cavity, the coolant water would not drain and would still provide necessary cooling to the target/blanket. As a result, the target/blanket cladding would not approach the failure temperature and this accident would not release radionuclides. Therefore, this scenario concerns a coolant pipe break outside the target cavity.

**Source Term.** Because of the number of independent ways to shut off the accelerator beam and to provide cooling to the target/blanket assembly, the limiting credible release from this scenario would be the entire inventory (about 70,000 liters) of water from the Target Heat Removal Primary System into the confinement building. Because DOE would maintain the

THRPS water at a relatively low temperature, energetic release of radionuclide inventory is not likely. Nonvolatile radionuclides probably would remain on wet or cold surfaces near the release event. DOE assumes a complete release of noble gases and halogens (i.e., 100-percent release fraction, 100-percent leak path factor). The estimated release fraction of other particulate radionuclides in the inventory would be 0.0002 (100 percent leak path factor). In addition, this scenario conservatively assumes the release of tritium as HTO (tritium oxide). The inventory was based on a 1,700 MeV proton energy LAHET/MCNP/CINDER90 calculation (Liscom-Powell 1997). The inventory includes the direct creation of radionuclides in the coolant, recoil atoms from the solid materials, and corrosion products. The source term released to the environment from this accident scenario is shown in Table B-4. This source term is independent of the tritium feedstock.

Table B-4. Large loss of coolant accident in the target heat removal primary system (outside the target/blanket cavity) source term.

Nuclide	Activity (Ci)
H-3	700,000
O-15	280,000
N-13	47,000
Kr-76	870
F-18	96
C-11	24
Ar-37	6.0
I-125	5.4
Xe-127	5.3
Be-7	0.040
Cr-51	0.02
Al-28	0.0010
P-30	0.00051
Sc-44	0.00050
Co-58	0.00040
Co-58m	0.00027
<b>Total</b>	<b>1,020,000</b>

**Likelihood.** The estimated range of frequency for a large loss-of-coolant accident in the Target Heat Removal Primary System is 0.001 per year. DOE does not consider other accident sequence outcomes (i.e., additional safety system

failures) that could lead to larger radiological releases to be credible due to the redundant and diverse systems in place to prevent overheating of the target/blanket. The estimated frequency of the LOCA inside the target cavity would be 0.001 per year.

**Consequence Estimates.** The analysis used the source term listed in Table B-4 to estimate the radiological dose and risk to downwind receptors. DOE used the MACCS2 code, using SRS-specific meteorological information, to conduct the dispersion analysis and compute downwind doses and projected latent cancer fatalities in the surrounding population.

The calculated dose to the Maximally Exposed Individual from this scenario is 0.03 rem. The calculated dose to the uninvolved worker at a distance of 640 meters is 2.8 rem. The calculated dose to the population within 50 miles would be 57 person-rem, which is postulated to result in 0.029 excess cancer fatalities.

### B.2.7 FULL POWER BEAM/BEAM STOP INTERACTION

**Scenario.** This accident would involve an inadvertent interaction between the full-power beam and the final beam stop. The scenario assumes that an equilibrium buildup of radionuclides in the beam stop (equivalent to 25 hours [effective] of full rated power [3.4 megawatts] per year for 40 years) would occur at the time of full-power (170 megawatts) focused beam interaction. The scenario also assumes that the interaction would occur immediately after the final 25-hour [effective] exposure to the 3.4-megawatt beam.

**Source Term.** DOE conservatively assumes that this accident would release the entire radionuclide inventory in the beam stop. Table B-5 lists the source term released to the environment.

**Likelihood.** The Beam Permit and Beam Shutdown Systems would have a number of interlocks that would prevent unanticipated beam interactions. System and operator failures

**Table B-5.** Full-power beam/beam stop interaction scenario source term.

Nuclide	Activity (curies)
C-11	120,000
Li-9	720
H-3	520
Be-7	590
Total	120,000

would have to occur to cause a full-power beam/beam stop interaction. DOE assumes that this scenario would have an occurrence frequency of not greater than 0.0001 per year.

**Consequence Estimates.** The analysis used the source term listed in Table B-5 to estimate the radiological dose and risk to downwind receptors. DOE used the MACCS2 code, using SRS-specific meteorological information, to conduct the dispersion analysis and compute downwind doses and projected latent cancer fatalities in the surrounding population.

The calculated dose to the Maximally Exposed Individual from this scenario is 0.0043 rem. The calculated dose to the uninvolved worker at a distance of 640 meters is 0.96 rem. The calculated dose to the population within 50 miles would be 5.0 person-rem, which is postulated to result in 0.0028 excess cancer fatalities.

### B.2.8 MISDIRECTION/MISFOCUSING OF HIGH-ENERGY BEAM (WITH LOSS OF CONFINEMENT)

**Scenario.** A worst-case beam misdirection or misfocusing incident coincident with the loss of the Beam Tunnel Confinement System would be a bounding accident for the accelerator. This scenario assumes that the accelerator beam would impinge on the beam tube for an extended period, causing an eventual breach of the tube. The scenario also assumes that, during this time, the Radiation Monitoring and Protection System would not detect the increased radiation levels and cause the beam to shutdown. Extended beam impingement would result in the generation of activated metal ions,

which the beam tube and surrounding structures would release, and activated air products, which beam interaction with air in the tunnel would produce. The accelerator would shut itself down after a breach of the beam tube. In addition, the scenario assumes that the beam tunnel confinement system would fail, causing an immediate release of radioactive material to the environment.

**Source Term.** The source term for this accident would consist of metal ions and activated air products generated from beam impingement and by the beam interaction with tunnel structures; the source term would be a function of several parameters, including duration, degree of beam misdirection/misfocusing, and location of impingement along the beam tube. The scenario assumes that the activated air inventory listed in Table B-2 would be present in the tunnel when the beam tube breach occurred. In addition to the activated air source term, the scenario assumes the vaporization of a 10-centimeter section of the beam tube, which would contribute activated metal ions to the source term. The analysis used LAHET/MCNP/CINDER90 to estimate the inventory of radionuclides in the accelerator structures, the basis of which would be 1,700 MeV protons impinging on the structure at 10 nA/m for 9 months. Table B-6 lists the dominant metal ion source term this accident would release, which the scenario assumes to be equivalent to the fraction of the activated beam tube vaporized by the event (1/10,000).

**Likelihood.** DOE believes that this event would be less likely than the accelerator loss-of-confinement scenario described in Section B.2.4 because of the additional requirement of beam burnthrough. For the bounding source term release (the sum of the source terms in Tables B-2 and B-6 is approximately 3.4 curies), DOE assumes that this event could occur at a frequency of 0.0001 per year.

**Consequence Estimates.** The analysis used the source terms listed in Tables B-2 and B-6 to estimate the radiological dose and risk to downwind receptors. DOE used the MACCS2

**Table B-6. Misdirection/misfocusing of high-energy beam scenario source term (metal ions only).**

Nuclide	Activity (curies)	Nuclide	Activity (curies)	Nuclide	Activity (curies)
Fe-55	0.045	V-49	0.0056	Co-55	0.0017
Mn-56	0.031	Co-56	0.0044	Cr-49	0.0017
Al-28	0.031	Ar-37	0.0039	Ni-57	0.0016
Mn-54	0.020	V-48	0.0034	P-32	0.0014
Na-24m	0.016	Co-58m	0.0031	Sc-47	0.0014
H-3	0.015	Si-31	0.0031	V-47	0.0013
Cr-51	0.013	K-42	0.0031	Fe-52	0.0013
O-15	0.0069	Ca-45	0.0025	Co-60	0.0012
Co-57	0.0068	Cu-62	0.0023	Cu-66	0.0012
Co-58	0.0064	Nb-93m	0.0022	Sc-46	0.0011
Cu-64	0.0061	Mn-51	0.0020	Y-88	0.0011
Mn-52	0.0058	Sc-44	0.0019	<b>Total</b>	<b>0.26</b>
				<b>Total (x 3)<sup>a</sup></b>	<b>0.77</b>

<sup>a</sup> Multiplied by 3 to account for other low-activity radioisotopes in source term.

code, using SRS-specific meteorological information, to conduct the dispersion analysis and compute downwind doses and projected latent cancer fatalities in the surrounding population.

The calculated dose to the Maximally Exposed Individual from this scenario is 0.000012 rem. The calculated dose to the uninvolved worker at a distance of 640 meters is 0.00078 rem. The calculated dose to the population within 50 miles would be 0.057 person-rem, which is postulated to result in 0.000029 excess cancer fatalities.

### B.2.9 TARGET-HANDLING ACCIDENT

**Scenario.** This scenario would involve dropping an irradiated target module during its removal and transport from the cavity to the target storage pool. DOE anticipates that retargeting the front target module would occur annually, and retargeting the back module every 2 years. Only one (front or back) module would be removed and transported at a time. For this scenario the bounding target module is the front module which will produce the highest decay heat. This would also bound a dropped blanket module. Active cooling will be provided during transfer.

The transfer will take place through or over a flooded canal, or over a region that can be flooded in the event of a dropped target module. If it is determined that additional cooling is necessary to prevent excessive releases of radionuclides. This design is an extension of what was presented in the conceptual design report. In this scenario it is assumed that the transport mechanism fails causing the target module to fall into the flooded canal or into the cavity. It is assumed that active cooling fails. If the target is dropped into the flooded canal, passive cooling is provided to the target module surfaces. If the target is dropped within the cavity, the cavity flood system is activated providing surface cooling to the dropped module.

**Source Term.** Analysis shows that with cooling of the target module external surfaces, temperatures remain minimal. No radionuclides are expected to be released.

**Likelihood.** Due to (1) the relatively infrequent transport of irradiated target modules, (2) the multiple systems that would have to fail during transport, and (3) the use of industry standards, practices, and procedures (e.g., commercial nuclear industry practices for performing heavy critical load lifts), this event could

occur with a frequency of 0.0001 per year (NRC 1980).

**Consequence Estimates.** The consequences are estimated to be negligible.

### B.2.10 FAILURE OF BEAM EXPANDER

**Scenario.** The proton beam has a power of 170 megawatts. During normal operation the diameter of the beam is several centimeters. Because of the high intensity of the beam, the beam expander spreads the power in the target. DOE has designed the system so that a single failure could not cause the temperature of the target to exceed design criteria. In addition, redundant, independent, diverse systems would detect system failures and cause a shutdown of the accelerator.

If all these systems failed, an accident could cause significant damage to the target/blanket system. The defocusing accident would cause a rapid failure of the target cavity window. As discussed above, the accelerator would not function without a vacuum. The coolant released into the accelerator when the window ruptured would shut the accelerator down. While the beam was shutting down, a local area of the target could melt.

**Source Term.** The resulting event is a loss-of-coolant accident inside the cavity with some target damage. As discussed above, the released material would remain in the cavity and or the target pool which would effectively contain aerosols. In addition, the HEPA filters, which would be intact and functioning, would collect radioactive particulates escaping from the pool.

**Likelihood** An occurrence of this event would require two or more failures in the beam expander mechanism and at least one fault in the detection system. The estimated frequency would be 0.00001 per year.

**Consequence Estimates.** Because of the containment of the consequences in the Cavity Vessel, the Retargeting Pool, and the confine-

ment HEPA filters, the consequences of this event would be negligible.

### B.2.11 DESIGN-BASIS SEISMIC EVENT

A design basis seismic event is postulated to occur. The target/blanket building and the tritium separation facility (He-3 feedstock material alternative only) are designed to withstand up to a 0.20g peak ground acceleration earthquake (performance category 3). The accelerator tunnel and the balance of the plant are designed to withstand a 0.15g peak ground acceleration earthquake (performance category 2).

The beam shutdown system, which is designed to performance category 3 seismic criteria, will rapidly terminate the beam. Since the beam is extremely sensitive to any misalignment, it is highly unlikely that the beam will not shutdown in the case of a seismic event of this magnitude. In addition, it is likely that off-site power will be lost and the beam will shut down.

The accelerator tunnel is postulated to collapse. The beamstop and beam stop cooling system may be damaged, but minimal release is expected. The material at risk is the activated air in the tunnel which is postulated to be released as a result of this event. This accident would release the same activated air radionuclides described in Section B.2.4.

The Target/Blanket Building will remain standing. The target/blanket modules, cavity vessel, target/blanket heat removal primary system, target/blanket residual heat removal systems, the cavity flood system, the beam expander zone, window and window purification system, confinement systems, electrical backup power and target remote handling system will not be damaged and will remain intact and maintain integrity. The target/blanket will remain cooled by the coolant in the headers and later by the residual heat removal system powered by the uninterruptable power supply for thirty minutes and the backup power supply system designed to performance category 3.

The Tritium Separation Facility Building, which is designed to performance category 3 criteria, will remain standing. However, systems and equipment inside the building may be damaged and tritium release may occur, since the systems and equipment are designed to lower seismic criteria. The material at risk is the tritium inventory in the systems.

It is conservatively assumed that the entire tritium inventory is released and oxidized.

The balance of plant buildings may fail and equipment damage may occur. The material at risk for the balance of plant is the radionuclides in the resin beds and various waste systems.

- Source Term for He-3 Feedstock Material alternative. The source term consists of the accelerator activated air (Table B-2), the tritium within the tritium separation facility (4.69 kilograms, Section B.2.14), and the resin bed radionuclides (twice the values of Table B-2 to conservatively account for both the target and blanket resin beds).
- Source Term for Lithium-6 Feedstock Material alternative. The source term consists of the accelerator activated air (Table B-2), and all resin bed radionuclides.

**Likelihood.** The occurrence frequency of a design basis seismic event is  $5E-4$  per year.

**Consequence Estimates.** The analysis used the source term listed above to estimate the radiological dose and risk to downwind receptors. DOE used the MACCS2 code, using SRS-specific meteorological information, to conduct the dispersion analysis and compute downwind doses and projected latent cancer fatalities in the surrounding population.

- He-3 Feedstock Material alternative - The calculated dose to the Maximally Exposed Individual from this scenario is 2.9 rem. The calculated dose to the uninvolved worker at a distance of 640 meters is 150 rem. The calculated dose to the population within 50 miles would be 5,100 person-rem,

which is postulated to result in 2.6 excess cancer fatalities.

- Lithium-6 Feedstock Material alternative - The calculated dose to the Maximally Exposed Individual from this scenario is 0.96 rem. The calculated dose to the uninvolved worker at a distance of 640 meters is 146 rem. The calculated dose to the population within 50 miles would be 1,600 person-rem, which is postulated to result in 0.8 excess cancer fatalities.

### B.2.12 BEYOND-DESIGN-BASIS SEISMIC EVENT

**Scenario.** DOE STD-1020 (DOE 1996) establishes requirements for DOE facilities for protection against natural phenomena hazards. The standards implement a philosophy of placing the structures, systems, and components (SSCs) in performance categories according to the safety function they perform and the level of hazards they protect against. The seismic event is one of the natural phenomena hazards analyzed. If an earthquake occurred which is much larger than used as a design basis significant. The continued functioning of facilities could not be assured. For this beyond design basis earthquake it is assumed that extensive damage could occur to all segments of the APT plant. If this happened the potential for significant releases would occur in the target/blanket and the tritium separation facility. In the analysis the following assumptions are made.

- The tritium separation facility fails and a facility fire releases and oxidizes all of the tritium inventory.
- The target/blanket SSCs have extensive damage and the following assumptions will be used to evaluate the release fraction.
  - The external loop and the residual heat removal system fails at the inlet and the outlet.

*Accidents*

- The tungsten neutron source ladders fail internally at the inlet and somewhere near the bottom.
- The cavity flood system is not actuated or is ineffective.
- The window fails.
- The cavity vessel remains intact

**Source Term.** As a result of the assumptions the target/blanket is uncooled from time zero. A radiation heat transfer calculation has been performed to determine the temperatures of the Inconel-clad tungsten rods. A cladding failure and tungsten release model that depends on time and temperature was developed based on experiments and literature data. This model was integrated over time using 125 percent of the nominal decay heat. A key parameter in the model is the Inconel failure temperature. The literature reports a range of 1,260°C to 1,330°C. A conservative failure temperature of 1,250°C was used which has been verified through experiment (Greene 1997). For this case a target damage fraction of 0% was calculated. This is based on a target design in which the power density is a factor of 1.4 less than the design reported in the conceptual design report.

The release from the blanket is dependent on the feedstock used to produce tritium. For both options, the release from the blanket is conservatively assumed to be 2 percent of the mercury based on analytical estimates (the actual release is expected to be smaller), 100 percent of the noble gases, 100 percent of the tritium. If the feedstock is He-3 the amount of tritium available for release from the He-3 and the aluminum tubes is 93.8 grams (LANL 1997). If the feedstock is Li-6, the amount of tritium available for release is 3 kg. The source term from the blanket is shown in Table B-7.

**Table B-7. Source Term for Beyond Design Basis Seismic scenario (blanket).**

Nuclide	Activity (Ci)	Nuclide	Activity (Ci)
Ar-37	85,000	Xe-135	400
Hg-197	31,000	Kr-76	390
Hg-195	17,000	Xe-133	340
Hg-193	8,700	Xe-121	230
Kr-83 <sup>m</sup>	5,210	Kr-85	140
Hg-203	4,900	Kr-74	110
Xe-125	4,000	Xe-138	56
Kr-85 <sup>m</sup>	3,900	Xe-135 <sup>m</sup>	36
Ne-19	3,600	Kr-81 <sup>m</sup>	29
Xe-127	3,200	Hg-195 <sup>m</sup>	25
Kr-88	3,200	Hg-199 <sup>m</sup>	12
Kr-87	3,100	Ar-39	11
Kr-79	2,800	Hg-194	10
Xe-123	1,400	Xe-131 <sup>m</sup>	9.7
Kr-77	960	Xe-129 <sup>m</sup>	5.8
Xe-122	680	Xe-133 <sup>m</sup>	5.0
Hg-197 <sup>m</sup>	600	Hg-193 <sup>m</sup>	0.41
Ar-41	500	Kr-81	0.013

Note: In addition, 3 kilograms of tritium is released for the Lithium-6 feedstock material and 93.8 grams of tritium is released for the He-3 feedstock material.

In addition to the release from the target/blanket it is assumed that: (1) all of the tritium in the tritium separation facility is released as oxide (He-3 option only), (2) the target primary coolant is released to the confinement (see Table B-3), (3) the blanket primary coolant is released to the confinement (see Table B-8), (4) accelerator activated air is released (Table B-2), and (5) radionuclides in the resin bed are released (twice the values of Table B-2 are used to conservatively account for both the target and blanket resin beds).

No credit is taken for retention of radionuclides in the confinement.



**Table B-8. Source Term for beyond design basis seismic scenario (blanket coolant).\***

Nuclide	Activity (Ci)
H-3	360,000
O-15	280,000
N-13	47,000
F-18	96
Ar-37	3.9
C-11	24
Be-7	0.040
Cr-51	0.016
Al-28	0.0010
P-30	0.00051
Sc-44	0.00049

**Likelihood.** In APT the critical target/blanket SSCs are designated performance category 3. Associated with each classification is a frequency of occurrence for the natural phenomena hazards that the SSC is designed to withstand. Performance category 3 has a frequency of occurrence of  $5 \times 10^{-4}$  per year. For events of higher magnitude and a lower frequency there is a design goal and associated probability of failure which for a performance category 3 seismic event is  $< 1 \times 10^{-4}$  per year. The event described in this scenario has an estimated frequency of  $< 1 \times 10^{-5}$  per year.

**Consequence Estimates.** The analysis used the source term listed above to estimate the radiological dose and risk to downwind receptors. DOE used the MACCS2 code, using SRS-specific meteorological information, to conduct the dispersion analysis and compute downwind doses and projected latent cancer fatalities in the surrounding population.

- He-3 Feedstock Material alternative - The calculated dose to the Maximally Exposed Individual from this scenario is 3.0 rem. The calculated dose to the uninvolved worker at a distance of 640 meters is 160 rem. The calculated dose to the population within 50 miles would be 5,500 person-rem, which is postulated to result in 2.7 excess cancer fatalities.

- Lithium-6 Feedstock Material alternative - The calculated dose to the Maximally Exposed Individual from this scenario is 1.7 rem. The calculated dose to the uninvolved worker at a distance of 640 meters is 200 rem. The calculated dose to the population within 50 miles would be 3,100 person-rem, which is postulated to result in 1.6 excess cancer fatalities.

**B.2.13 FAILURE TO TRIP ACCELERATOR BEAM DURING A THERMAL HYDRAULIC TRANSIENT IN THE TARGET (BEYOND DESIGN BASIS ACCIDENT)**

**Scenario.** During thermal hydraulic transient events such as a reduction in or loss of primary coolant flow due to the failure of one or more primary coolant pumps, analyses have indicated that the APT tungsten targets and lead blankets would not be damaged as long as the accelerator beam is shutdown. However, if a reduction in flow or a loss of cooling transient of this nature were to occur without a beam shutdown, the targets or blankets could be damaged and result in the release of some radionuclides into the target cavity.

**Source Term.** In the event of a reduction in or loss of primary coolant flow in the tungsten target without beam shutdown, the coolant flow would decrease but the energy deposition into the target would remain at full power. For this condition to occur, numerous independent and redundant active beam shutdown sensors in the primary cooling system, which are intended to signal the shutdown of the beam in the event of just such transients, would all have to simultaneously fail. These include sensors to detect and signal changes in the loop flows, pressures, temperatures and the pump status, among others. If it is assumed that these active beam shutdown sensors fail to detect the thermal hydraulic transient and shutdown the accelerator,

the continued deposition of energy into the target would cause the critical heat flux to be exceeded in the target rungs, and the tungsten rod bundles could soon be voided of water. Subsequently, the tungsten target rods and support structures would rapidly heat up, resulting in structural failure of some of the target ladders. Upon over-temperature failure of some target ladders, a loss-of-coolant accident would occur in the target primary cooling system (TPCS) inside the target cavity which would then flood the target cavity with heavy water from the TPCS. For the accelerator beam to remain on at this point, all active beam shutdown sensors in the cavity which are intended to detect moisture, high radiation, and pressure inside the target cavity would have to simultaneously fail. The pressurizer level sensors would also have to fail to detect the decreasing water level in the pressurizer. If all the active beam shutdown sensors just described failed to shutdown the accelerator beam, the next line of defense would be the passive vent between the target cavity atmosphere and the high energy beam transport (HEBT). As the target cavity was filling with water from the LOCA in the TPCS, a passive (always open) vent line between the target cavity atmosphere and the HEBT would allow steam/moisture from the cavity to enter the HEBT vacuum. Once steam/moisture enters the HEBT and is detected by the additional active beam shutdown sensors in the HEBT, fast-acting gate valves would be signaled to close, thus isolating and protecting the accelerator from the HEBT and the target cavity. This signal would also shutdown the accelerator. If this signal fails to shutdown the accelerator, steam/moisture would race down the accelerator at sonic speed, shorting out the RF cavities and the ion source, finally rendering the accelerator physically incapable of further operation. The radionuclides that were released from the damaged target modules into the target cavity would remain mostly contained in the target cavity; only negligible amounts of these radionuclides would be transported into the accelerator components through the HEBT-cavity vent line. The flooding of the target cavity by the internal LOCA would submerge the damaged targets and the blankets under water. If

necessary, the target cavity flood system could be actuated to maintain the submergence of the targets and the blankets and to ensure long-term coolability. However, the cooling loops of the blanket modules which are undamaged would continue to operate and remove heat from the water in the flooded cavity. As a result, the water in the cavity could remain subcooled even without actuation of the target cavity flood system. This would eliminate the need to vent the target cavity; therefore, the release of radionuclides from the cavity into the confinement would not be expected. Any steam generated by the decay heat in the targets in the flooded target cavity could be vented and scrubbed through the nuclear air filtration system of the confinement building or the target cavity vacuum system, or the steam could be condensed in the spent target pool if such a flow path is made available. Either method would mitigate the release of radionuclides from the target cavity.

**Likelihood.** The APT design includes redundant and diverse means to shutdown the accelerator beam and the primary cooling loops have multiple pumps in parallel so that the probability of such an accident would be extremely small. An estimate of the frequency of such an event which could have the potential for an environmental release is much less than  $10^{-6}$ , placing this event into the residual risk range.

**Consequence Estimates.** This accident could cause damage to the target, but the release of radionuclides into the target cavity would be small, probably limited to a small fraction of the volatile spallation products in the tungsten and some of the tritium in the heavy-water coolant. Off-site consequences would be negligible.

#### **B.2.14 LARGE FIRE IN TRITIUM SEPARATION FACILITY**

**Scenario.** This postulated event is a large fire in the Tritium Separation Facility that involved all the radioactive material (tritium) in the building. The fire could start anywhere in the TSF and the scenario assumes that it would

spread to engulf the TSF building. The initiator could be a small fire that spreads.

**Source Term.** The scenario assumes a release of all the tritium in the Tritium Separation Facility as tritium oxide. The maximum inventory of tritium allowed in the TSF would be 4,690 grams. All oxidized tritium would be immediately released (i.e., a release fraction 1.0) from the building. Even though the analysis based its evaluation of the consequences of this unmitigated release, the facility would have a number of detection and mitigative features [oxygen sensors, tritium cleanup system, nitrogen atmosphere in the glove boxes, secondary confinement structures (double wall piping), radiation monitoring; fire suppression system that would significantly reduce the probability and consequences of a release, etc.].

**Likelihood.** The estimated frequency of an unmitigated, large fire-induced tritium release would be 0.0001 per year.

**Consequence Estimates.** The analysis used the 4,690-gram source term to estimate the radiological dose and risk to downwind receptors. DOE used the MACCS2 code, with SRS-specific meteorological information, to conduct the dispersion analysis and compute projected downwind doses and latent cancer fatalities to the surrounding population.

The calculated dose to the Maximally Exposed Individual from this scenario is 1.9 rem. The calculated dose to the uninvolved worker at a distance of 640 meters is 8.1 rem. The calculated dose to the population within 50 miles would be 3,500 person-rem, which is postulated to result in 1.7 excess cancer fatalities.

### B.2.15 SMALL FIRE IN TRITIUM SEPARATION FACILITY

**Scenario.** This postulated event is a small fire in the Tritium Separation Facility. This fire

would be localized in a small area of the facility or in an individual component, and would be extinguished (or would not grow) before it could become a larger (room or facility) fire.

**Source Term.** The design requirements of the Tritium Separation Facility would limit the maximum inventory of tritium that could be released and oxidized to 469 grams. This value corresponds to the inventory of a single processing system or component (single-point release) and the scenario assumes that the fire would not progress to other components or systems. All the oxidized tritium would be immediately released (release fraction of 1.0) from the building. Even though the analysis based its evaluation of the consequences on this unmitigated release, the facility would have a number of detection and mitigative features [oxygen sensors, tritium cleanup system, nitrogen atmosphere in the glove boxes, secondary confinement structures (double wall piping), radiation monitoring; fire suppression system that would significantly reduce the probability and consequences of a release, etc.].

**Likelihood.** The estimated frequency of an unmitigated, small fire-induced tritium release would be 0.01 per year.

**Consequence/Risk Estimates.** The analysis used the 469-gram source term to estimate the radiological dose and risk to downwind receptors. DOE used the MACCS2 code, with SRS-specific meteorological information, to conduct the dispersion analysis and compute downwind dose and projected latent cancer fatalities to the surrounding population.

The calculated dose to the Maximally Exposed Individual from this scenario is 0.21 rem. The calculated dose to the uninvolved worker at a distance of 640 meters is 7.0 rem. The calculated dose to the population within 50 miles would be 360 person-rem, which is postulated to result in 0.18 excess cancer fatalities.

## References

- Chanin, D. and Young, M., 1997, Code Manual for MACCS2: Volume 1, User's Guide, SAND97-0594, March.
- DOE (U.S. Department of Energy), 1994, "Preparation Guide for U.S. Department of Energy NonReactor Nuclear Facility Safety Analysis Reports," DOE-STD-3009-94, July.
- DOE (U.S. Department of Energy), 1996, "Natural Phenomena Hazards Design and Evaluation Criteria for Department of Energy Facilities," DOE-STD-1020-94, January.
- EPA (U.S. Environmental Protection Agency) and NOAA (National Oceanic and Atmospheric Administration), 1992, *ALOHA (Areal Location of Hazardous Atmospheres) Users Manual*, Washington, D.C., October.
- Greene, G. A., 1997, "Oxidation of Inconel 718 in Air at High Temperatures," BNL Formal Report (In Preparation).
- LANL (Los Alamos National Laboratory), 1989, User Guide to LCS: The LAHET Code System, LA-UR-89-3014, September.
- LANL (Los Alamos National Laboratory), 1993, Accelerator Transmutation Studies at Los Alamos with LANET, MCNP, and CINDER-90, LA-UR-93-3080, January.
- LANL (Los Alamos National Laboratory), 1997, Conceptual Design Report, LA-UR-97-1329, U.S. Department of Energy, Los Alamos, New Mexico, April.
- Liscom-Powell, J., 1997, APT EIS Accident Consequences Calculations, SNL-9364-JLPS1997-02, October.

# Appendix C

List of Plants and Animals Mentioned in the APT EIS

---

**APPENDIX C**

**LIST OF PLANTS AND ANIMALS  
MENTIONED IN THE APT EIS**

## APPENDIX C. LIST OF PLANTS AND ANIMALS MENTIONED IN THE APT EIS

Group	Common name	Scientific name
Plants	Alligator-weed	<i>Alternanthera philoxeroides</i>
	American elm	<i>Ulmus americana</i>
	Arrowhead	<i>Sagittaria</i> spp.
	Bald cypress	<i>Taxodium distichum</i>
	Black cherry	<i>Prunus serotina</i>
	Black gum	<i>Nyssa sylvatica</i>
	Black willow	<i>Salix nigra</i>
	Blackberry	<i>Rubus</i> spp.
	Blueberry	<i>Vaccinium</i> spp.
	Box elder	<i>Acer negundo</i>
	Broom sedge	<i>Andropogon virginicus</i>
	Bulush	<i>Scirpus</i> spp.
	Cat-tail	<i>Typha</i> spp.
	Dog-fennel	<i>Eupatorium capillifolium</i>
	Dogwood	<i>Cornus</i> spp.
	Greenbrier	<i>Smilax</i> spp.
	Hickory	<i>Carya</i> spp.
	Holly	<i>Ilex opaca</i>
	Japanese honeysuckle	<i>Lonicera japonica</i>
	Lespedeza	<i>Lespedeza</i> spp.
	Loblolly pine	<i>Pinus taeda</i>
	Muscadine grape	<i>Vitis rotundifolia</i>
	Persimmon	<i>Diospyros virginiana</i>
	Red maple	<i>Acer rubrum</i>
	Red oak	<i>Quercus rubra</i>
	Laurel oak	<i>Quercus laurifolia</i>
	Sassafras	<i>Sassafras albidum</i>
	Slash pine	<i>Pinus elliotti</i>
	Smooth coneflower	<i>Echinacea laevigata</i>
	Sparkleberry	<i>Vaccinium arboreum</i>
	Spike-rush	<i>Eleocharis</i> spp.
	Sweet-gum	<i>Liquidambar styraciflua</i>
Water shield	<i>Brasenia schreberi</i>	
Water tupelo	<i>Nyssa aquatica</i>	
White oak	<i>Quercus alba</i>	
Winged sumac	<i>Rhus copallina</i>	

Group	Common name	Scientific name
Benthic macroinvertebrates	Wintergreen	<i>Gaultheria procumbens</i>
	Yellow jessamine	<i>Gelsemium</i> spp.
	Amphipods (scuds, sideswimmers)	Amphipoda
	Aquatic Insects	
	"True" bugs (hemipterans)	Hemiptera
	"True flies" and midges (dipterans)	Diptera
	Backswimmers (corixids)	Corixidae
	Beetles	Coleoptera
	Blackflies	Simuliidae
	Caddisflies (trichoptera)	Trichoptera
	Dragonflies (odonates)	Odonata
	Mayflies (ephemeropterans)	Ephemeroptera
	Midges (chironomids)	Chironomidae
	Sandburrowing mayfly	<i>Dolania americana</i>
	Springtails	Collembola
	Stoneflies (plecopterans)	Plecoptera
	Clams and mussels	Pelecypoda
	Decapods (crayfishes, shrimps)	Decapoda
	Flatworms	Turbellaria
	Leeches	Hirudinea
Nematodes (roundworms)	Nematoda	
Oligochaetes (aquatic earthworms)	Oligochaeta	
Snails and limpets (gastropods)	Gastropoda	
Fish	American shad	<i>Alosa sapidissima</i>
	Atlantic sturgeon	<i>Acipenser oxyrinchus</i>
	Black crappie	<i>Pomoxis nigromaculatus</i>
	Blueback herring	<i>Alosa aestivalis</i>
	Bluegill	<i>Lepomis macrochirus</i>
	Bluehead chub	<i>Nocomis leptocephalus</i>
	Bluespotted sunfish	<i>Enneacanthus gloriosus</i>
	Brook silverside	<i>Labidesthes sicculus</i>
	Brown bullhead	<i>Ameiurus nebulosus</i>
	Channel catfish	<i>Ictalurus punctatus</i>
	Coastal shiner	<i>Notropis petersoni</i>
	Creek chubsucker	<i>Erimyzon oblongus</i>
	Gizzard shad	<i>Dorosoma cepedianum</i>
	Golden shiner	<i>Notemigonus crysoleucas</i>
Lake chubsucker	<i>Erimyzon sucetta</i>	



Group	Common name	Scientific name
	Largemouth bass	<i>Micropterus salmoides</i>
	Minnows	<i>Notropis</i> spp.
	Mosquitofish	<i>Gambusia holbrooki</i>
	Mud sunfish	<i>Acantharchus pomotis</i>
	Pirate perch	<i>Aphrododerus sayanus</i>
	Redbreast sunfish	<i>Lepomis auritus</i>
	Redear sunfish	<i>Lepomis microlophus</i>
	Shortnose sturgeon	<i>Acipenser brevirostrum</i>
	Spotted sucker	<i>Minytrema melanops</i>
	Spotted sunfish	<i>Lepomis punctatus</i>
	Striped bass	<i>Morone saxatilis</i>
	Threadfin shad	<i>Dorosoma petenense</i>
	Warmouth	<i>Lepomis gulosus</i>
	Yellow perch	<i>Perca flavescens</i>
	Yellowfin shiner	<i>Notropis lutipinnis</i>
Reptiles and amphibians	American alligator	<i>Alligator mississippiensis</i>
	Black racer	<i>Coluber constrictor</i>
	Eastern fence lizard	<i>Sceloporus undulatus</i>
	Southern toad	<i>Bufo terrestris</i>
Birds	(Common) screech owl	<i>Otus asio</i>
	(Common) yellow-shafted flicker	<i>Colaptes auratus</i>
	(Northern) mockingbird	<i>Mimus polyglottos</i>
	American (common) crow	<i>Corvus brachyrhynchos</i>
	Bald eagle	<i>Haliaeetus leucocephalus</i>
	Carolina wren	<i>Troglodytes ludovicianus</i>
	Common (northern) bobwhite	<i>Colinus virginianus</i>
	Eastern bluebird	<i>Sialia sialis</i>
	Mourning dove	<i>Zenaida macroura</i>
	Pine warbler	<i>Dendroica pinus</i>
	Prairie warbler	<i>Dendroica discolor</i>
	Red-bellied woodpecker	<i>Melanerpes carolinus</i>
	Red-cockaded woodpecker	<i>Picoides borealis</i>
	Red-eyed vireo	<i>Vireo olivaceus</i>
	Red-tailed hawk	<i>Buteo jamaicensis</i>
	Rufous-sided towhee	<i>Pipilo erythrophthalmus</i>
	Sharp-shinned hawk	<i>Accipiter striatus</i>
	Wood stork	<i>Mycteria americana</i>
	Wood thrush	<i>Hylocichla mustelina</i>
Mammals	Beaver	<i>Castor canadensis</i>

Group	Common name	Scientific name
	Eastern cottontail	<i>Sylvilagus floridanus</i>
	Feral hog	<i>Sus scrofa</i>
	Fox squirrel	<i>Sciurus niger</i>
	Gray fox	<i>Urocyon cinereoargenteus</i>
	Gray squirrel	<i>Sciurus carolinensis</i>
	Marsh rabbit	<i>Sylvilagus palustris</i>
	Mink	<i>Mustela vison</i>
	Muskrat	<i>Ondatra zibethicus</i>
	Otter	<i>Lutra canadensis</i>
	Raccoon	<i>Procyon lotor</i>
	Red fox	<i>Vulpes vulpes</i>
	Rice rat	<i>Oryzomys palustris</i>
	Star-nosed mole	<i>Condylura cristata</i>
	(Virginia) opossum	<i>Didelphis virginiana</i>
	White-tailed deer	<i>Odocoileus virginianus</i>