

**SUPPLEMENTAL STACK EFFLUENT MONITORING**  
**AT THE**  
**SAFETY LIGHT CORPORATION**  
**BLOOMSBURG, PENNSYLVANIA**

**P. W. FRAME**

Prepared By

Radiological Site Assessment Program  
Manpower Education, Research, and Training Division  
Oak Ridge Associated Universities

Prepared For

Division of Fuel Cycle and Material Safety  
U.S. Nuclear Regulatory Commission

FINAL REPORT

November 1982

SUPPLEMENTAL STACK EFFLUENT MONITORING  
AT THE  
SAFETY LIGHT CORPORATION  
BLOOMSBURG, PENNSYLVANIA

Prepared for

Division of Fuel Cycle and Material Safety  
U.S. Nuclear Regulatory Commission

P.W. Frame

Project Staff

J.D. Berger	R.C. Gentry
R.D. Condra	C.F. Weaver
G.R. Foltz	

Prepared by

Radiological Site Assessment Program  
Manpower Education, Research, and Training Division

FINAL REPORT

November 1982

This report is based on work performed under Interagency Agreement DOE No. 40-770-80, NRC Fin. No. A-9090 between the U.S. Nuclear Regulatory Commission and the U.S. Department of Energy. Oak Ridge Associated Universities performs complementary work under contract number DE-AC05-76OR00033 with the U.S. Department of Energy.

TABLE OF CONTENTS

	<u>Page</u>
List of Figures . . . . .	ii
List of Tables. . . . .	iii
Introduction. . . . .	1
Site Description. . . . .	1
Survey Procedures . . . . .	2
Results . . . . .	5
Summary . . . . .	6
References. . . . .	17
Appendices:	
Appendix A: Major Sampling and Analytical Equipment	
Appendix B: Analytical Procedures	

LIST OF FIGURES

	<u>Page</u>
FIGURE 1: Photo of a Portion of Columbia County, Pennsylvania, Showing the Location of the U.S. Radium/Safety Light Corporation. . .	7
FIGURE 2: Plot Plan of the U.S. Radium Site Indicating the Area Occupied by Safety Light Corporation. . . . .	8
FIGURE 3: EPA Standard Method 1 Criteria for Performing Air Velocity Measurements in Circular Ducts . . . . .	9
FIGURE 4: Photograph of a Stack Sampling Probe Showing the Sampling Nozzle, Positioning Plate, and In-Line Particulate Filter Holder . . . . .	10
FIGURE 5: Diagram of Stack Sampling System for Particulate, Aqueous, and Gaseous Tritium . . . . .	11
FIGURE 6: Locations of Off-Site Environmental Air Sampling Stations . . . . .	12
FIGURE 7: Diagram of Environmental Air Sampling System for Tritium. . . . .	13
FIGURE 8: Wind Rose for Bloomsburg, Pennsylvania, Area During the Survey Period of August 16-20, 1982. . . . .	14

LIST OF TABLES

	<u>Page</u>
TABLE 1: Air Sampling Flow Rates and Volumes . . . . .	15
TABLE 2: Air Monitoring Results. . . . .	16

SUPPLEMENTAL STACK EFFLUENT MONITORING  
AT THE  
SAFETY LIGHT CORPORATION  
BLOOMSBURG, PENNSYLVANIA

INTRODUCTION

At the request of the Nuclear Regulatory Commission (NRC), the Radiological Site Assessment Program of Oak Ridge Associated Universities (ORAU) conducted an environmental survey of the Safety Light Corporation (SLC), Bloomsburg, PA, during the summer of 1981.<sup>1</sup> This survey was performed as part of the continuing regulatory and inspection process of licensees' radiation control and monitoring programs. Deficiencies in the ORAU stack sampling equipment, discovered following the survey, resulted in erroneous measurements of stack discharge concentrations. Therefore, a supplemental survey of gaseous effluents from SLC operations was performed during the period of August 16-20, 1982.

SITE DESCRIPTION

General

Safety Light Corporation is located approximately 5 km east/northeast of Bloomsburg, PA, on a portion of the site operated by U.S. Radium (Figure 1). The entire U.S. Radium site occupies about 4 hectares and is bounded on the north by Old Berwick Road and on the south by the Susquehanna River. Safety Light Corporation activities, which are enclosed by a security fence, occupy approximately 0.6 hectares on the eastern portion of the site (Figure 2). Safety Light Corporation is licensed by the NRC to use tritium in the production of luminous signs and dials, paints, gas chromatograph foils, and accelerator targets. Manufacturing processes are conducted in one building; a second building houses solid radioactive waste handling and storage activities and a third building houses liquid waste collection, dilution and discharge equipment.

## Airborne Effluents

Operations involving possible airborne releases are performed under exhaust ventilation. Silica gel (indicating-type) columns and molecular sieve back-up columns are used for treatment of gas streams with potentially high concentrations of tritium. These are replaced when needed as determined by observation of the silica gel. The old columns are disposed of as solid waste. All building exhausts are combined for discharge through a single stack, 0.6 m in diameter and 18 m high. Continuous monitoring of this stack for particulate, aqueous and gaseous forms of tritium is performed using filters and ethylene glycol bubblers in conjunction with an oxidizer furnace. Filters and ethylene glycol solutions are changed and analyzed daily. The licensee has determined diffusion factors for the exhaust stream under predominant meteorological conditions (wind toward the southeast) and utilizes this diffusion to satisfy the concentration guidelines for release to unrestricted areas. Monitoring for aqueous tritium is also performed at three locations along the SLC property boundary (northeast, east, and southeast of the stack) and at two private off-site residences located approximately 0.3 km east and 0.3 km northeast of the SLC stack. Samples from the SLC property boundary locations are collected and analyzed weekly; at each of the three off-site locations, seven day samples are collected and analyzed four times per year.

## SURVEY PROCEDURES

### Objectives

The objectives of this survey were to monitor routine releases of tritium in the stack air and the resultant levels in the environment. The data obtained would be used to confirm measurements performed by the licensee and to evaluate the adequacy and accuracy of the control and monitoring procedures.

### Stack Effluent Monitoring

The single stack, containing exhaust from all operations, was sampled for tritium concentrations. Approximately 6 m (10 duct diameters)

downstream of the point where the fan discharge enters the stack, two holes were drilled in the duct. To determine the isokinetic sampling rate, stack velocities were measured using a pitot tube and a swinging vane anemometer. An eight point traverse was made at each access hole. Figure 3 summarizes the criteria for selection of measurement points.

The sampling nozzle was selected to provide isokinetic sampling at a rate of approximately 10 l/min. The nozzle was attached to a probe, inserted in the stack, and supported by a metal plate secured in position on the stack by flexible straps. The selected location for placement of the sampling nozzle represented the point where the cross-sectional area is divided into an inner circle and outer annulus of equal areas. The air flow pattern at this point was relatively constant over a distance of several centimeters. The exact sampling rate to achieve isokinetic sampling was calculated to be 10.3 l/min.

For the first two days of sampling, the collection train included both a primary and a secondary system. The latter was run in parallel with part of the primary system, both for comparative purposes and as a backup. On the third day of sampling, the primary system was used exclusively.

The primary sample collection system consisted of a 47 mm diameter membrane filter (0.8  $\mu$ m pore size) to remove particulates; a four-stage ethylene glycol trap to remove tritium in the form of water vapor; an oxidizer furnace containing palladium sponge catalyst for converting gaseous tritium to water vapor; and a final three-stage ethylene glycol trap. The secondary sampling system of two five-stage molecular sieve traps in conjunction with an oxidizer furnace was used in parallel with the ethylene glycol system. Separate needle valves and rotameters were used to control and monitor the flow in these systems at 0.8 l/min. A third rotameter assembly monitored a by-pass line. All three lines were connected to an 85 l/min vacuum pump. A photograph of the stack probe and filter holder assembly is shown in Figure 4 and a diagram of the sampling "train" is shown in Figure 5.

After installation of the probe assemblies and connection of the vacuum, control, and measurement equipment, air flows were adjusted to the desired sampling rate. Times and flow rates were noted. Samples were



collected over a 24-hour period. Several checks of flow rate were made during this period to assure that the desired flows were being maintained. The sampling media were replaced at the end of 24 hours and a second series of 24-hour samples collected. This was repeated to collect a third set of 24-hour samples. Flow rates and sample volumes are summarized in Table 1.

#### Environmental Air Sampling

Air samples were collected at the four off-site locations indicated in Figure 6. Three of these samplers (1, 2, and 3) were located approximately 200 m northeast of the SLC stack and were suspended 3-4 m above the ground on two telephone poles and a tree, respectively. Each sampler consisted of a particulate filter and two molecular sieve cartridges. The sampling rate for each unit was 1.3 l/min. After collection of particulate and aqueous tritium, the air streams from the three samplers were combined. A fraction (1.2 l/min) of this combined stream was passed through an oxidizer furnace and two more molecular sieve cartridges to determine the average gaseous tritium concentration. Sampling was performed for 87 hours with periodic checks to assure proper sampling rates. A diagram of this system is shown on Figure 7.

Sampler 4 consisted of three ethylene glycol bubblers installed in parallel with the licensee's off-site sampler located approximately 350 m northeast of the stack. This sampler was operated at 1 l/min for a period of approximately three days.

Wind speed and direction were monitored during the sampling periods. The wind rose developed from this data is presented on Figure 8.

#### Analytical Equipment and Procedures

Samples were returned to laboratories in Oak Ridge for analysis. Appendix A contains a list of the major sampling and analytical equipment used for this survey. Analytical procedures are described in further detail in Appendix B.

## RESULTS

### Stack Effluent Concentrations

Results of the stack effluent and environmental monitoring are presented in Table 2.

Overall, the stack concentrations determined by ORAU and SLC are in agreement. This is particularly evident when the average values for the entire sampling period are considered. Only two individual measurements by SLC and ORAU differed by more than a factor of 3. In one case, the tritium concentration determined by ORAU for the particulate filter on the final day of sampling ( $1 \times 10^{-8}$   $\mu\text{Ci/ml}$ ) was 3.7 times that measured by SLC ( $2.69 \times 10^{-9}$   $\mu\text{Ci/ml}$ ). This difference may partially be explained by the different positions in the stack of the ORAU and SLC sampling nozzles and the greater distance between SLC's sampling nozzle and particulate filter. The latter factor may have resulted in some uncompensated plate-out of tritium in SLC's sampling lines. In the other case, the gaseous tritium concentration measured by ORAU on the first day of sampling ( $7.2 \times 10^{-6}$   $\mu\text{Ci/ml}$ ) was 72 times that reported by SLC ( $0.1 \times 10^{-6}$   $\mu\text{Ci/ml}$ ). No reason for this difference could be determined. However, it should be noted that the value reported by ORAU is consistent with those reported by both groups for the following two days of sampling.

The average concentrations of aqueous tritium at the point of discharge (18 m above ground level) calculated by ORAU and SLC were 10-11 times and 13 times, respectively, the average annual guideline levels established by the NRC for unrestricted areas.<sup>2</sup> The concentrations of particulate and gaseous tritium were determined to be less than 20% of the guideline levels for unrestricted areas.

### Environmental Samples

The off-site air samplers located 200 m northeast of the SLC stack (locations 1-3) collected concentrations of all three forms of tritium well below the guideline levels for unrestricted areas (Table 2). Analysis of the wind rose data presented in Figure 8 indicates that these samplers were downwind of the stack for approximately 10% of the total sampling period.

On this basis, it can be concluded that the tritium concentrations in the plume at the specified height (3-4 m) and distance (200 m) from the stack of the samplers were less than 1% of the guideline levels. Given an effective stack height of 18 m and stability classes ranging from B to D, the maximum ground level concentrations were calculated to be found between 150 and 350 m downwind of the stack. The samplers, therefore, were reasonably well positioned in order to determine these maximum ground level concentrations.

The concentrations of aqueous tritium in the samplers collected by ORAU and SLC at location 4 were determined to be  $<7 \times 10^{-11}$   $\mu\text{Ci/ml}$  and  $2.1 \times 10^{-10}$   $\mu\text{Ci/ml}$  respectively. However, these results are not directly comparable due to differences in the SLC and ORAU sampling periods. Like locations 1-3, location 4 was located to the northeast and estimated to be downwind of the stack for approximately 10% of the total sampling period. As such, the average concentration in the plume at this point is well below the guideline level of  $2 \times 10^{-7}$   $\mu\text{Ci/ml}$ .

As a cross check of our analytical procedures, two tritium-containing samples of ethylene glycol were split between ORAU, SLC, and NUS, an outside laboratory contracted by SLC. The determinations by ORAU, SLC, and NUS were  $1.5 \times 10^{-1}$ ,  $1.7 \times 10^{-1}$ , and  $1.4 \times 10^{-1}$   $\mu\text{Ci/ml}$  for sample 1, and  $4.3 \times 10^{-2}$ ,  $3.7 \times 10^{-2}$ , and  $2.9 \times 10^{-2}$   $\mu\text{Ci/ml}$  for sample 2, respectively.

#### SUMMARY

Supplemental stack effluent monitoring was performed at the Safety Light Corporation in Bloomsburg, PA, on August 16-20, 1982.

Monitoring of the SLC stack effluents at the point of release indicated concentrations of aqueous tritium above the guideline levels established for unrestricted areas. However, environmental air sampling off-site indicated that the levels of all forms of tritium, including aqueous tritium, were well within the guidelines. Analyses performed by both ORAU and SLC of the stack effluents produced comparable results. It is concluded that the environmental tritium monitoring and control program established by SLC is adequate.

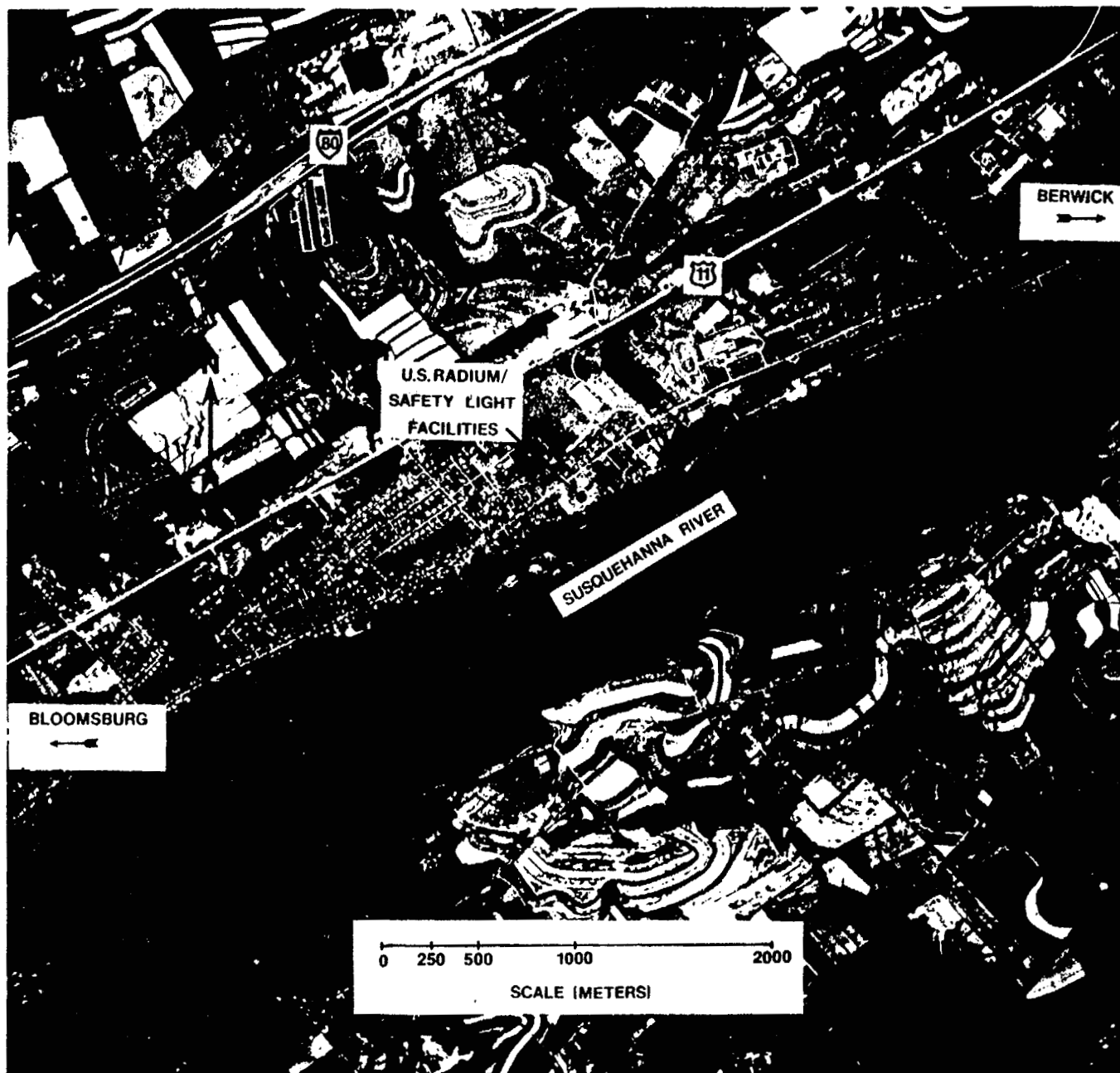

FIGURE 1. Photo of a Portion of Columbia County, Pennsylvania, Showing the Location of the U.S. Radium/Safety Light Corporation.

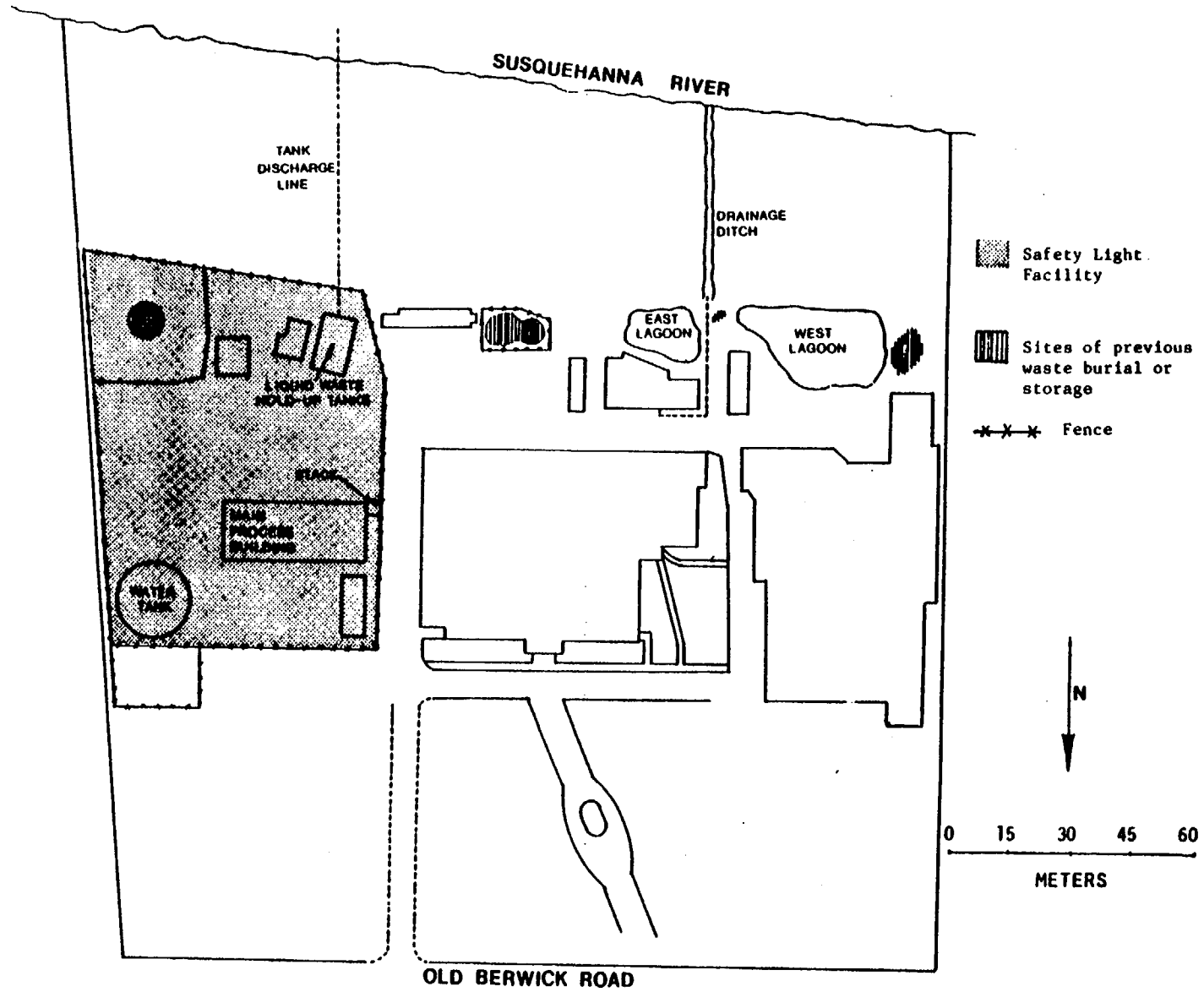
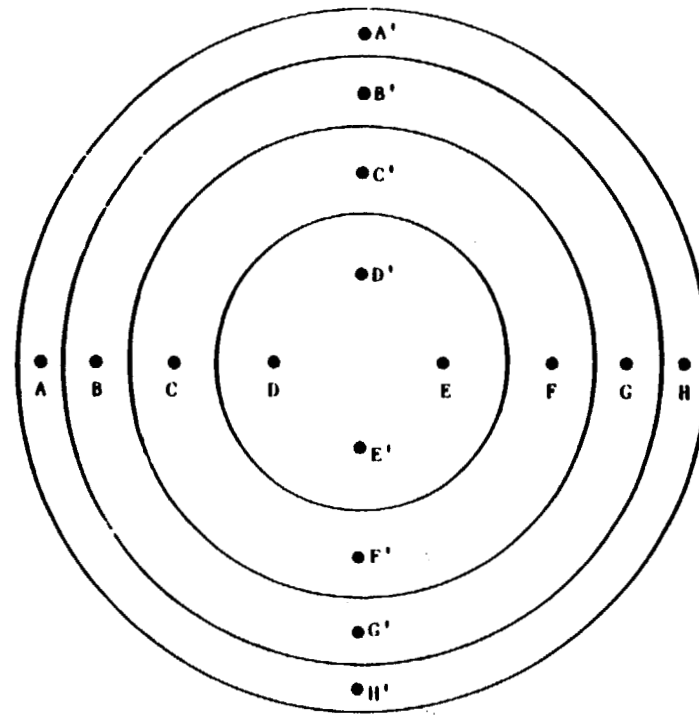

FIGURE 2. Plot Plan of the U.S. Radium Site Indicating the Area Occupied by Safety Light Corporation.



Duct Diameter (cm)	# of Points Per Traverse	DISTANCES OF POINTS FROM DUCT WALL (fraction of duct diameter)											
		A	B	C	D	E	F	G	H	I	J	K	L
<61	8	.032	.105	.194	.323	.677	.806	.895	.968	-	-	-	-
>61	12	.021	.067	.118	.177	.250	.356	.644	.750	.823	.882	.933	.979

FIGURE 3. EPA Standard Method 1 Criteria for Performing Air Velocity Measurements in Circular Ducts.

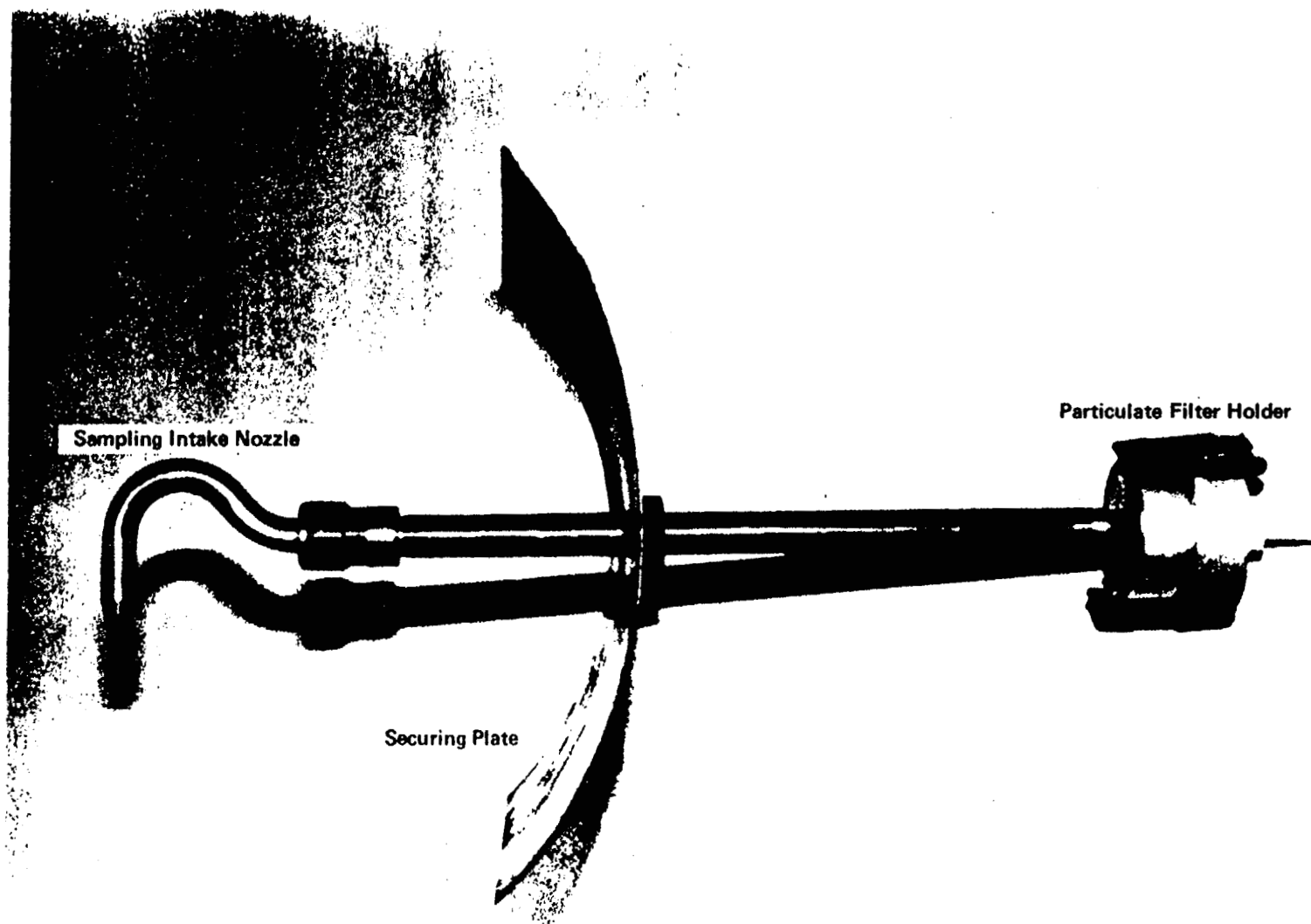

FIGURE 4. Photograph of a Stack Sampling Probe Showing the Sampling Nozzle, Positioning Plate, and In-Line Particulate Filter Holder. (For this photograph the nozzle has been rotated 90° from its usual position relative to the securing plate.)

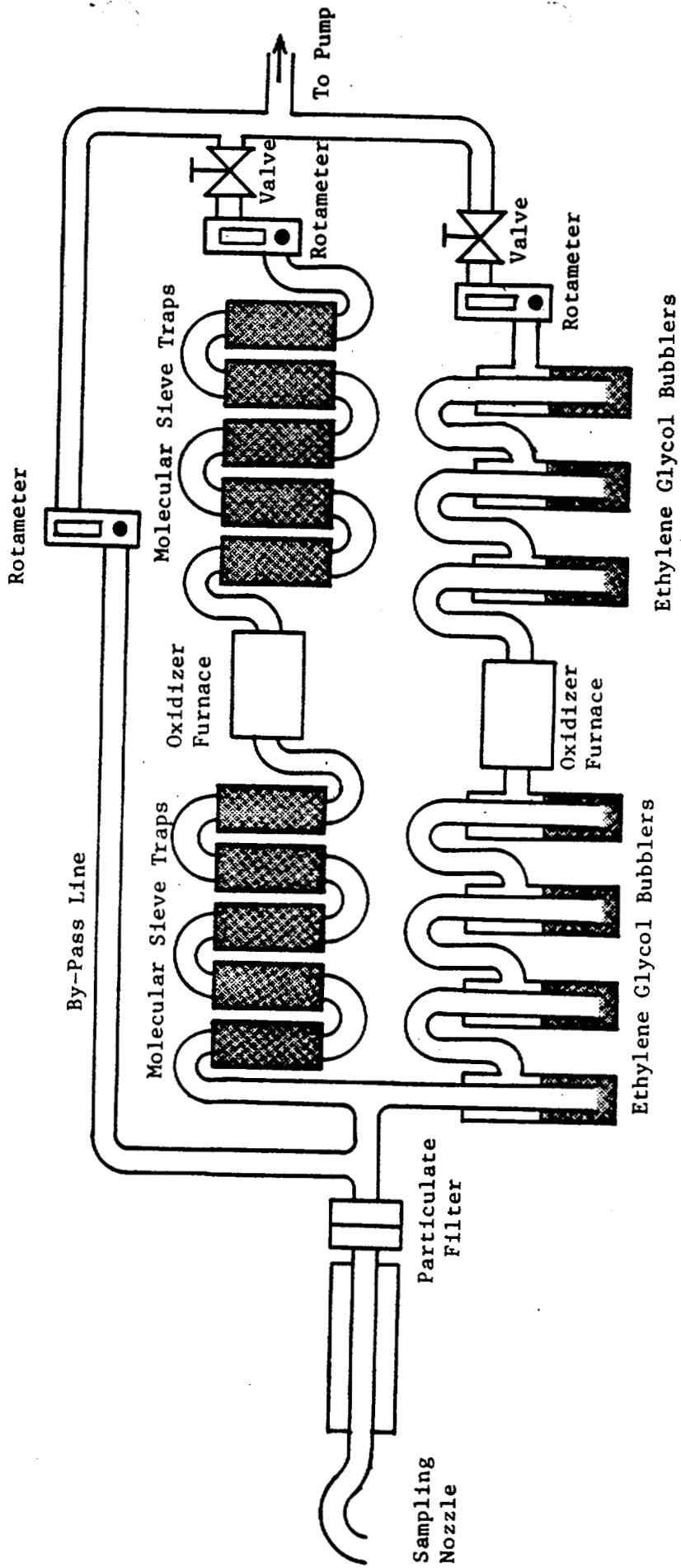

FIGURE 5. Diagram of Stack Sampling System for Particulate, Aqueous, and Gaseous Tritium.





FIGURE 6. Locations of Off-Site Environmental Air Sampling Stations.

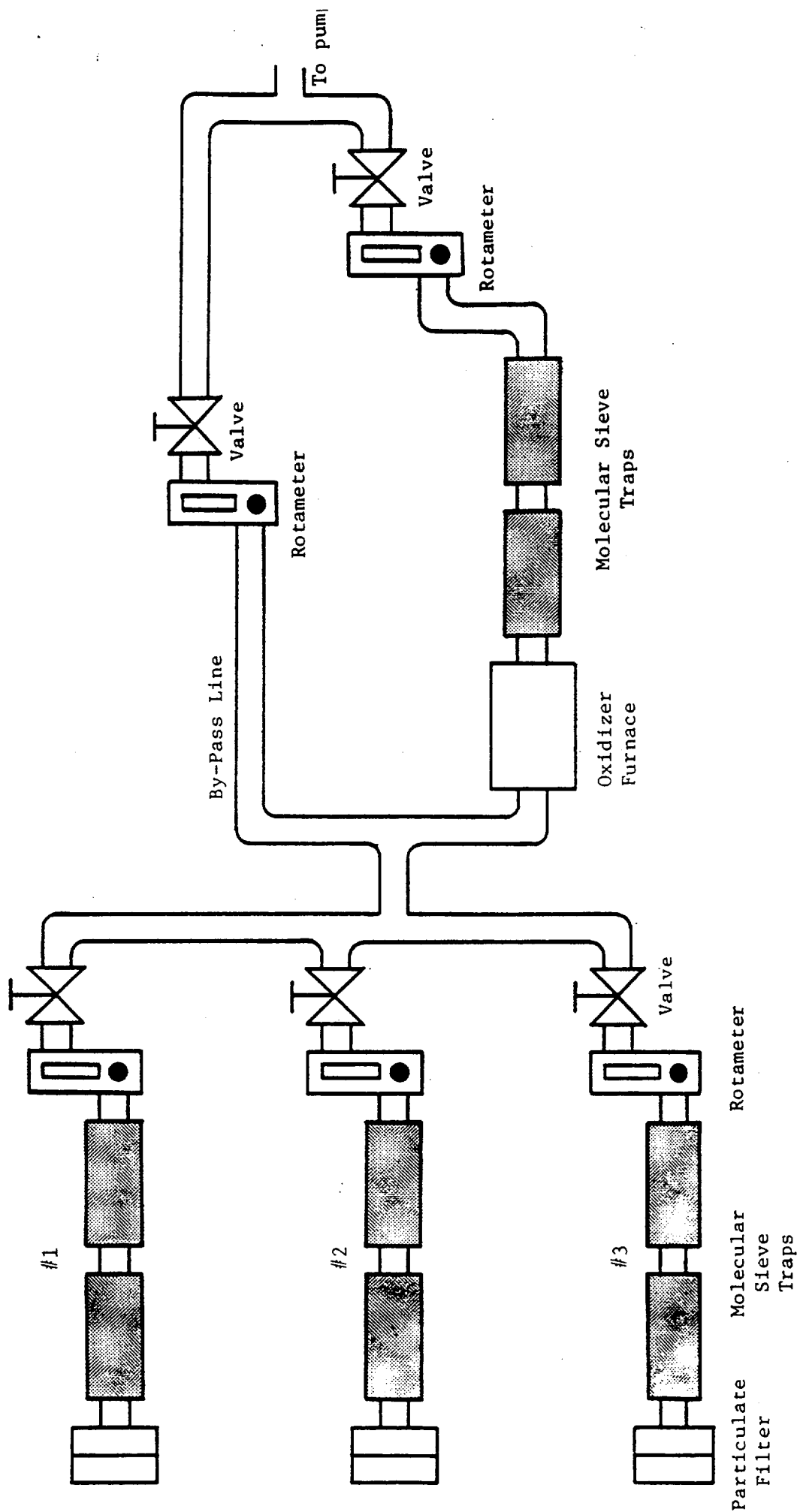

FIGURE 7. Diagram of Environmental Air Sampling System for Tritium.

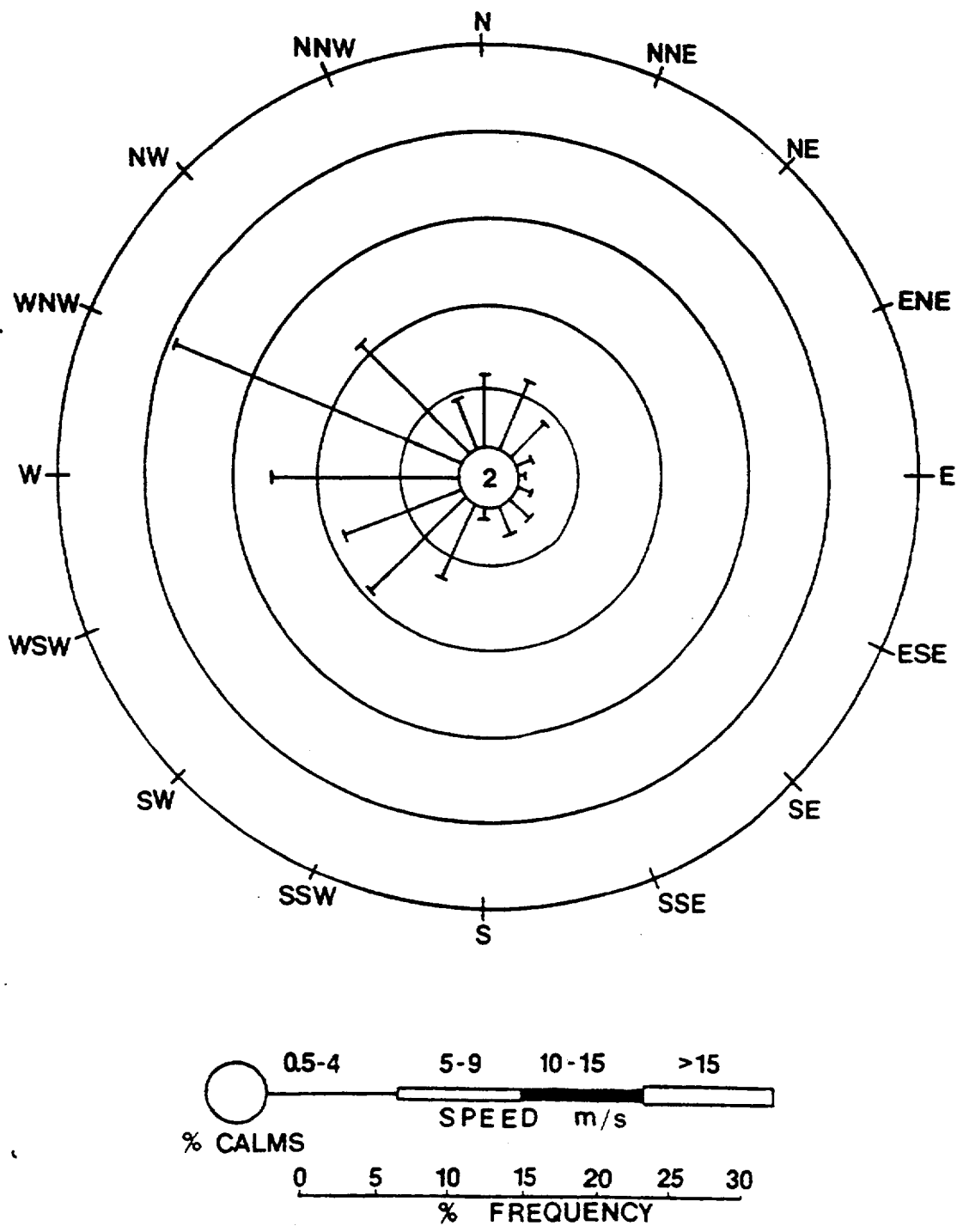

FIGURE 8. Wind Rose for Bloomsburg, Pennsylvania, Area During the Survey Period of August 16-20, 1982.

TABLE 1

## AIR SAMPLING FLOW RATES AND VOLUMES

Sample Type & Location	Velocity at Sampling Point (m/min)	Initial Sampling Rate (l/min)	Date	Sampling Time (min)	Sample Volume <sup>a</sup> (l)	Sampling Media
<u>Stack</u>	683	10.3	8/17-18/82	1380	$1.42 \times 10^4$	Particulate filter
	"	0.8	"	"	$1.10 \times 10^3$	Ethylene glycol bubblers
	"	0.75	"	"	$9.32 \times 10^2$	Molecular sieve traps
	683	10.3	8/18-19/82	1380	$1.42 \times 10^4$	Particulate filter
	"	0.8	"	"	$1.10 \times 10^3$	Ethylene glycol bubblers
	"	0.75	"	"	$1.04 \times 10^3$	Molecular sieve traps
	683	10.3	8/19-20/82	1440	$1.44 \times 10^4$	Particulate filter
	"	0.8	"	"	$1.02 \times 10^3$	Ethylene glycol bubblers
	<u>Environmental</u> <sup>b</sup>					
1	NA <sup>c</sup>	1.3	8/16-20/82	5195	$8.83 \times 10^3$	Particulate filter and molecular sieve trap
2	NA	1.3	"	"	$5.88 \times 10^3$	"
3	NA	1.3	"	"	$6.98 \times 10^3$	"
Combined Streams 1, 2, & 3	NA	1.2	"	"	$6.10 \times 10^3$	Molecular sieve trap after oxidizer furnace
4	NA	1	8/17-20/82	4027	$4.21 \times 10^3$	Ethylene glycol bubblers

<sup>a</sup> Sample volume adjusted for slight changes in flow rate during sampling period.

<sup>b</sup> Refer to Figure 6.

<sup>c</sup> Not Applicable.

TABLE 2  
AIR MONITORING RESULTS

Sample Type & Location	Date	Analysis by	Tritium Concentration ( $\mu\text{Ci/ml}$ )			Sampling Media
			Particulate	Aqueous	Gaseous	
<b>Stack:</b>						
	8/17-18/82	ORAU	$6.16 \pm 0.02 \times 10^{-10}$ <sup>a</sup>	$1.22 \pm 0.05 \times 10^{-6}$	<sup>c</sup>	Ethylene Glycol
		"	--	$1.58 \pm 0.01 \times 10^{-6}$	$7.20 \pm 0.01 \times 10^{-6}$	Molecular Sieve
		SLC	--	$2.76 \times 10^{-6}$	$0.1 \times 10^{-6}$	Ethylene Glycol
	8/18-19/82	ORAU	$1.31 \pm 0.01 \times 10^{-9}$	$2.02 \pm 0.06 \times 10^{-6}$	<sup>c</sup>	Ethylene Glycol
		"	--	$2.12 \pm 0.01 \times 10^{-6}$	$7.94 \pm 0.01 \times 10^{-6}$	Molecular Sieve
		SLC	$0.77 \times 10^{-9}$	$3.77 \times 10^{-6}$	$5.70 \times 10^{-6}$	Ethylene Glycol
	8/19-20/82	ORAU	$1.00 \pm 0.01 \times 10^{-8}$	$2.80 \pm 0.02 \times 10^{-6}$	$3.06 \pm 0.07 \times 10^{-6}$	Ethylene Glycol
		SLC	$2.69 \times 10^{-9}$	$1.23 \times 10^{-6}$	$6.00 \times 10^{-6}$	Ethylene Glycol
	Average	ORAU	$3.98 \times 10^{-9}$	$2.01 \times 10^{-6}$	$3.06 \times 10^{-6}$	Ethylene glycol
		"	--	$1.85 \times 10^{-6}$	$7.57 \times 10^{-6}$	Molecular Sieve
		SLC	$1.73 \times 10^{-9}$	$2.59 \times 10^{-6}$	$3.93 \times 10^{-6}$	Ethylene glycol
<b>Environmental:</b>						
1	8/16-20/82	ORAU	$3.66 \pm 0.59 \times 10^{-12}$	$4.45 \pm 3.11 \times 10^{-11}$	$9.20 \pm 1.88 \times 10^{-11}$	Molecular Sieve
2	"	"	$2.68 \pm 1.07 \times 10^{-12}$	$2.94 \pm 0.64 \times 10^{-11}$	--	Molecular Sieve
3	"	"	$8.60 \pm 5.73 \times 10^{-13}$	$3.28 \pm 2.84 \times 10^{-11}$	--	Molecular Sieve
4	9/17-20/82	ORAU	--	$<7.00 \times 10^{-11}$ <sup>b</sup>	--	--
		SLC	--	$2.1 \times 10^{-10}$	--	--
<b>NRC Guideline</b>						
<b>Level for Unrestricted Areas</b>			2 $\times 10^{-7}$	2 $\times 10^{-7}$	4 $\times 10^{-5}$	

<sup>a</sup> Errors are 2 $\sigma$  based on counting statistics only.

<sup>b</sup> ORAU and SLC results at location 4 are not directly comparable due to differences in their respective sampling periods.

<sup>c</sup> A blown fuse in the power supply to the oxidizer furnace caused a poor collection of gaseous tritium for the ethylene glycol samplers during the first two days of sampling.

## REFERENCES

1. J.D. Berger, Radiological Site Assessment Program, Oak Ridge Associated Universities, Environmental Survey of the Safety Light Corporation, Bloomsburg, Pennsylvania. Unpublished Report, July 1982.
2. Title 10, Code of Federal Regulations, Part 20, Standards for Protection Against Radiation. 1981.
3. Title 40, Code of Federal Regulations, Part 60, Standards of Performance for New Stationary Sources. 1977.

**APPENDIX A**  
**MAJOR SAMPLING AND ANALYTICAL EQUIPMENT**

## APPENDIX A

### Major Sampling and Analytical Equipment

The display or description of a specific product is not to be construed as an endorsement of that product or its manufacturer by the authors or their employers.

#### A. Air Sampling

##### Aluminum In-Line Filter Holders

47 mm

Cat. #996209

(Research Appliance Co., Cambridge, MD)

##### Stack Sampling Nozzles

(NuTech Corp., Durham, NC)

##### Rotameters

(Union Carbide Corp., Linde Air Products Div.,  
Birmingham, AL)

##### Membrane Particulate Filters

Metrical, 47 mm diam., 0.8 um pore size

(Gelman Sciences, Inc., Ann Arbor, MI)

##### Molecular sieve

Type 4A, 14 x 30 mesh

(Linde Division, Union Carbide Corp., South Plainfield, NJ)

##### Oxidizer Furnace

30 watts/in. Serial #B-73494

(Industrial Heater, New York, NY)

##### Palladium Sponge (10 g/furnace)

(Englehard Chemicals, Newark, NJ)

##### Gast Vacuum Pump

115v/60Hz

Cat. #P8400

(American Scientific Products, Stone Mountain, GA)

##### Velometer - all purpose set

Type 6000 a.p.

(Alnor Instrument Co., Niles, NJ)

##### "Precision" Wet Test Meter

Used to calibrate rotameters

(Precision Scientific Co., Chicago, IL)

##### Additional supplies

Plastic tubing, miscellaneous connectors, bubblers



B. Laboratory Analysis

Liquid Scintillation Counter

Model A300C

(Packard Instrument Co., Downers Grove, IL)

**APPENDIX B**  
**ANALYTICAL PROCEDURES**

## APPENDIX B

### Analytical Procedures

#### Air Samples

Filter papers were placed directly into liquid scintillation cocktails and analyzed in a Packard liquid scintillation spectrometer.

One milliliter of ethylene glycol from each bubbler and 21 ml of BBOT scintillation cocktail were placed in counting vials for analysis. Analysis was by standard liquid scintillation spectrometry.

Molecular sieve was placed in a distillation flask, 20 ml of low-tritium water added, and the mixture heated to 375°C. Nitrogen was used as the carrier gas for the process. An 8 ml aliquot of the distillate was mixed with 14 ml of Insta-Gel cocktail and analyzed by liquid scintillation spectrometry.

Both the collection efficiencies and number of collection stages were high enough to ensure that essentially all of the tritium in the sampled air stream was collected.

#### Calibration and Quality Assurance

Laboratory instruments are calibrated using NBS-traceable standards. Portable survey equipment for exposure rate measurement is calibrated by comparing its response with that of a pressurized ionization chamber having NBS-certified calibration provided by the supplier.

The ORAU laboratory participates in the EPA Quality Assurance Program.