

5-22-01	1
6-7-2000	D
RECIPIENT UNDER GIVEN TO OTHER	
HOL	
INTERNA	
MOLTEC CENTR	
SSS LINCOLN	
MARLTON, NJ	
PROJECT NO. 504	
355	

NOTES:
 1. SEE SHEET 1 FOR NOTES WHICH APPLY TO THIS DRAWING.
 2. DIMENSIONAL TOLERANCE SHALL CONFORM TO TABLE UNLESS OTHERWISE NOTED.
 TOLERANCES SHALL NOT BE CUMULATIVE.

C.6

TOLERANCES (SEE NOTE 2)		
DIMENSION TYPE	RANGE (INCHES)	TOLERANCE (INCHES)
LINEAR	> 12	±0.13
	< 12	±0.06
HOLE DIA.	ANY SIZE	+0.08
	ANY SIZE	-0
RADIUS	ANY SIZE	±0.06

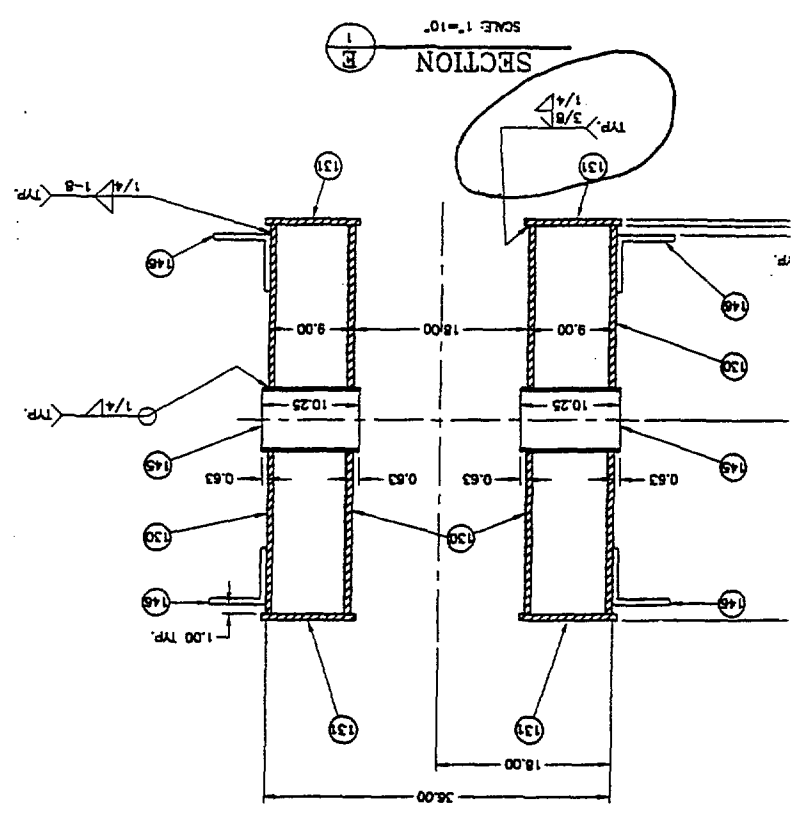
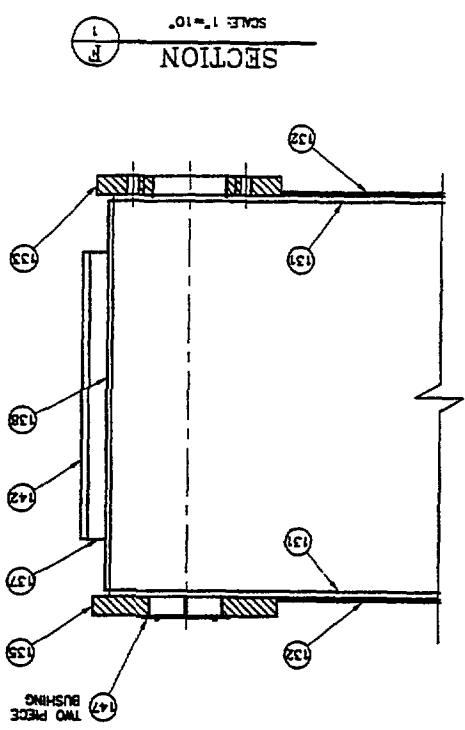

More detailed records were hit and miss
 ∴ This is what Ross got
 and described in IR

QPV-195 dtd 5/3/02
 written on CTF welds documentation

F-24

24

69

CASK TRANSFER FACILITY

Weld Data Sheet - 3116 - Lifting Platform

Weld Information Weld ID	Welder, WPS & Weld Material			NDE Information								
	Welder ID	WPS	Weld Wire ID	VT	Initial	Date	PT	Initial	Date	MT	Initial	Date
1/8" Fillets				X			n/a			n/a		
"				X			n/a			n/a		
"				X			n/a			n/a		
JK587413 1/4" Fillets	B	81	L56 MP30 LOT 5705	X	SND	9/20/00	n/a			n/a		
KD475624 ML 5/17/01 "	D	81	L56 MP30 LOT 5705	X	SND	9/20/00	n/a			n/a		
"				X			n/a			n/a		
J1587413 5/16" Fillets	B	81	L56 MP30 LOT 5705	X	SND	9/20/00	n/a			n/a		
"				X			n/a			n/a		
"				X			n/a			n/a		
3/8" Fillets				X			n/a			n/a		

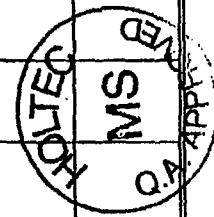

Page 2-65

NDE Materials

Penetrant _____ Batch _____ MT Yoke S/N _____
 Cleaner/Remover _____ Batch _____ Powder _____
 Developer _____ Batch _____

NDE Procedures: VT - HSP-211 Rev. 12 PT - HSP-201 Rev. ___ MT - HSP-204 Rev. ___

Prepared by: *[Signature]*
 Reviewed by: *[Signature]* 9/1/00
[Signature] 1 of 2

CASK TRANSFER FACILITY

Weld Data Sheet - 3116 - Lifting Platform

Weld Information Weld ID	Welder, WPS & Weld Material			NDE Information								
	Welder ID	WPS	Weld Wire ID	VT	Initial#	Date	PT	Initial	Date	MT	Initial	Date
3/8" Fillets	C	81	E1505-6 LOT 5205	X	SND	9/20/02	n/a				n/a	
"				X			n/a				n/a	
Partial Penetration	B	85	L61. 142F30 LOT 570R	X	SND	9/20/02	n/a				n/a	
"			Flux 570N	X			n/a				n/a	
"				X			n/a				n/a	

B475654
 KD475624
 ml 5/17/01
 A103006
 U1980300811
 ml 5/17/01

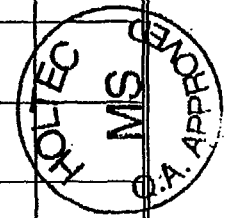

Page 2 - 66

NDE Materials

Penetrant _____ Batch _____ MT Yoke S/N _____
 Cleaner/Remover _____ Batch _____ Powder _____
 Developer _____ Batch _____ Batch _____

NDE Procedures: VT - HSP-211 Rev. 12 PT - HSP-201 Rev. ___ MT - HSP-204 Rev. ___

All Compl _____ 'ds must be stamped.

Prepared by: [Signature]
 Reviewed by: [Signature] 9/1/02
[Signature] 2002 5/1/00